

UNIVERSAL  
LIBRARY

**OU\_156638**

UNIVERSAL  
LIBRARY



Call No.

Accession No.

Author

Title

This book should be returned on or before the date last marked below.

**(continued from front flap)**

**In addition to the conventional topics, the text includes a complete study of levers, pulleys, gears and gear trains and mechanisms. The subject of centroids and moments of inertia of plane areas have been covered in a treatment which involves no mathematics beyond trigonometry. Emphasis is placed upon fundamental principles, and all topics are discussed and illustrated with many numerical solutions. There is a practical treatment of elementary dynamics, making the text particularly effective as a preliminary to the study of machine design.**

**In the new edition there are many new problems selected from practical examples in various applications.**

**THE PENNSYLVANIA STATE COLLEGE  
INDUSTRIAL SERIES**



**MECHANICS**

THE  
PENNSYLVANIA STATE COLLEGE  
INDUSTRIAL SERIES

BRENEMAN · *Mathematics*, 2d ed.

BRENEMAN · *Mechanics*, 2d ed.

BRENEMAN · *Strength of Materials*

SCHAEFER · *Job Instruction*

SCHAEFER · *Safety Supervision*

SCHAEFER AND WISSLER · *Industrial  
Supervision—Organization*

SCHAEFER AND WISSLER—*Industrial  
Supervision—Controls*

THAYER—*Blue Print Reading and  
Sketching*

THAYER · *Industrial Drawing*

WALTON · *Do You Want to Be a Foreman?*

WALTON · *The Fundamentals of Industrial  
Psychology*

WHITE (Editor) · *Practical Physics*

*INDUSTRIAL SERIES*

# MECHANICS

*By John W. Breneman, C.E.*

PROFESSOR OF ENGINEERING MECHANICS

Prepared under the Direction  
of the Division of Engineering Extension  
THE PENNSYLVANIA STATE COLLEGE

SECOND EDITION

NEW YORK TORONTO LONDON  
McGRAW-HILL BOOK COMPANY, INC.

1948

## MECHANICS

Copyright, 1941, 1948, by The Pennsylvania State College. Printed in the United States of America. All rights reserved. This book, or parts thereof, may not be reproduced in any form without permission of the publishers.

## **PREFACE TO THE SECOND EDITION**

In the revised edition of "Mechanics," the author has clarified a number of statements, corrected some mistakes, and rewritten entire paragraphs. However, the general arrangement and scope of the first edition have been retained. Many of the changes have been suggested by teachers and students who have used the original text. It is hoped that the revision will prove to be more useful in all lines of training.

A large number of problems have been added. These have been selected from a variety of sources. Some of the old problems have been deleted for the purpose of providing a better balanced selection for problem assignments.

Because of the large number of persons who have contributed to this revision, it is impossible for the author to give individual credit. It is his hope that the value of the improvements will justify the efforts of all who have expressed an interest in the work and who have made the revision possible.

**JOHN W. BRENNEMAN**

STATE COLLEGE, PA.  
*July, 1948*



## PREFACE TO THE FIRST EDITION

This text on mechanics is another in the series that has been written for the purpose of providing a study of the subject for the person who desires to further his knowledge of engineering fundamentals. It has been thoroughly tested in the fields of industrial training and in correspondence instruction prior to its publication in printed form. Unlike many of the texts on this subject, it incorporates the study of simple machines, gears, gear trains, pulleys, and mechanisms.

The problems are taken from practical examples in various applications and are discussed and explained with fundamental principles of the subject constantly in mind. Many examples have been solved to illustrate the phase of the subject matter being considered.

The book includes the treatment of conditions of equilibrium in static structures, a discussion on center of gravity and moment of inertia (without the use of mathematics beyond the level of trigonometry) and dynamics.

The author wishes to thank J. M. Holme for his helpful suggestions and constructive criticisms in the preparation of this book. He is also grateful to the Carnegie-Illinois Steel Corporation for its permission to reproduce certain tables from the Carnegie Pocket Companion as found in the appendix.

JOHN W. BRENEMAN

STATE COLLEGE, PA.  
*June, 1941*



## CONTENTS

<i>Preface to the Second Edition.</i> . . . . .	v
<i>Preface to the First Edition.</i> . . . . .	vii
<i>Foreword</i> . . . . .	xi
I. Fundamental Principles of Mechanics. . . . .	1
<i>Resolutions of Forces</i>	
II. Equilibrium of Forces in One Plane. . . . .	14
III. Simple Machines . . . . .	27
IV. Equilibrium of Nonconcurrent Forces in One Plane . . . . .	39
<i>Bridge and Roof Trusses</i>	
V. Screws and Threads . . . . .	54
VI. Friction and the Inclined Plane. . . . .	76
VII. Centroids . . . . .	85
VIII. Moment of Inertia . . . . .	91
IX. Motion and Velocity. . . . .	99
X. Force and Acceleration . . . . .	104
XI. Curvilinear Motion and Rotation. . . . .	109
XII. Work, Energy, and Power. . . . .	117
<i>Appendix.</i> . . . . .	125
<i>Index.</i> . . . . .	143



## FOREWORD

This volume is one of a series of texts prepared by members of the staff of the School of Engineering of The Pennsylvania State College. While these books may be of value in college teaching and elsewhere, their principal purpose is for use in adult teaching.

Experience in extension service indicates that there is a great lack of teaching materials suitable for the instruction of adult classes. Such extension classes at The Pennsylvania State College are composed of individuals who wish to study material which has fairly direct application. This is particularly true of students working in industry who carry on part-time study, as well as others who are preparing for jobs in industry. A common school education may make up the entire formal schooling of many of these students. Such students qualify by reason of self-education in many cases, and an experience in industry which constitutes a valuable apprenticeship as well.

Extension instructors are selected on the basis of their practical experience in a particular field as well as on the basis of their academic preparation. It follows, therefore, that text materials used in such classes should be readily readable, understandable, and "practical."

The author of this volume on Mechanics, J. W. Breneman, Professor of Engineering Mechanics in the School of Engineering, has incorporated in this volume some of the results of a wide experience in the fields of industrial engineering training as well as teaching on the college level. Altogether, three books covering Mechanics, Strength of Materials, and Mathematics have been prepared and used in a temporary form for several years before being put into their final printed form. It is hoped that this book will play an important part in practical industrial training programs in progress throughout this country.

This Industrial Series will include texts on mathematics, blueprint reading, engineering drawing, mechanics, strength of materials, machine design, electricity, and others. While a modicum of theory will be included, stress will be laid on the application of principles of these subjects to important practical problems that are common in industry.

E. L. KELLER, DIRECTOR  
DEPARTMENT OF ENGINEERING EXTENSION



## CHAPTER I

### FUNDAMENTAL PRINCIPLES OF MECHANICS

Mechanics is that science which treats of the effect of forces upon the form or motion of bodies. In general, the subject of mechanics is divided into statics and dynamics. When the forces that act on a body are so balanced as to cause no change in its motion, a state of equilibrium exists, and the problem comes under the division of statics. When the forces that act on a body cause some change in its motion, the problem comes under the division of dynamics.

In beginning a study of mechanics, four fundamental quantities must be considered: *space*, *matter*, *force*, and *time*. All are elementary, and they cannot be reduced to anything simpler. Problems of statics involve all these quantities except *time*, while problems in dynamics involve all of them.

The amount of material (or matter) in a body is called the *mass* of the body. Two bodies have equal masses if they produce equal deformations in a third body when they are applied to it under identical conditions. The ordinary spring balance is a common form of third body for the comparison of masses.

A force is a push or pull that tends to change the motion of a body. It causes a change of motion unless it is balanced by an equal and opposite force acting on the body, or by a number of forces equivalent to an equal and opposite force. Force is recognized and measured by means of the effects that it produces on bodies of known mass.

Too much cannot be said concerning the use of correct units in the solution of problems in mechanics. Amounts of mass or weight must be reduced to pounds, a ton being considered as containing 2,000 lb. Likewise, the unit of force is the pound, and all amounts must be changed to this unit. Space or distance in feet must be used. Time will be used either in seconds or minutes depending on the data given or required. It will be used in seconds unless otherwise stated.

Forces always occur in pairs, so that if there is a force from the first body to the second body, there is an equal and opposite force from the second body to the first body. This fact was established by Newton in what is called *the third law of motion*, which states that

action and reaction are always equal and act in opposite directions. In studying forces, three things must be determined for each force: the amount or value, the direction, and the point of application of the force.

**Fundamental Conceptions of Forces.**—In many cases, it is found desirable to represent forces by lines called *vectors*. A force is completely defined when its point of application, its direction, and its magnitude (amount) are known. These three characteristics are the same as those of any straight line, namely, its starting point, its direction, and its length.

If, therefore, we wish to show by means of a drawing that a force of 6 lb. acts at an angle of  $30^\circ$  to the horizontal and is applied at the

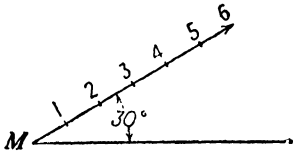

FIG. 1.

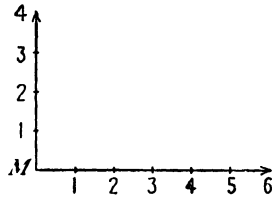

FIG. 2.

point  $M$ , Fig. 1, we draw a vector through  $M$  making an angle of  $30^\circ$  with a horizontal line, and lay off six units upon it. The length of this vector represents the amount of the force, the direction of the vector represents the direction of the force, and the starting point of the vector represents the point where the force is applied.

Again, let it be required to show by means of a drawing the fact that two forces are acting together at the point  $M$ , Fig. 2, one being a force of 6 lb. acting horizontally toward the right and the other a force of 4 lb. acting vertically upward. Draw two straight lines, one horizontally to the right and six units long and the other vertically upward and four units long. These two vectors represent the required forces.

**Composition of Forces.**—Any two forces acting upon a body at the same point may be replaced by a single force that will produce the same effect upon the body as is produced by the combined action of the two forces. The replacing of two forces by a single force that will produce the same result is known as *composition of forces*.

Assume that the point  $A$ , Fig. 3, is being pulled to the right by a force of 10 lb. and at the same time is being pulled vertically upward by a force of 10 lb. It is evident that the combined action of these two forces upon the point must be the same as if some single force

were acting in a direction somewhere between the two given forces. If, as in Fig. 3, the two forces are equal in amount, it may be seen from symmetry that the motion of the point will be in the direction of a line halfway between the directions of the two forces. The vector  $R$ , therefore, represents the direction of the equivalent, or resulting, force.

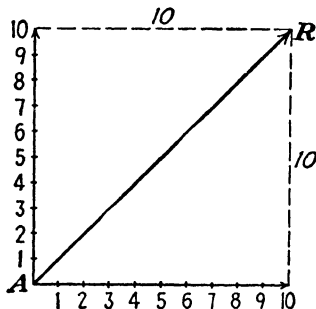

FIG. 3.

If, however, the point  $A$ , Fig. 4, is acted upon by two *unequal* forces, such as  $AD$  and  $AB$ , the equivalent, or resulting, force no longer will be exactly halfway between them, but it will be shown both in amount and direction by the diagonal  $AC$  of the parallelogram having  $AD$  and  $AB$  as sides. The separate forces, such as  $AD$  and  $AB$ , which act at a point are called *components*, while the resulting force which is equivalent to these components is called the *resultant*.

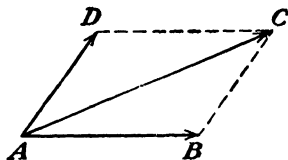

FIG. 4.

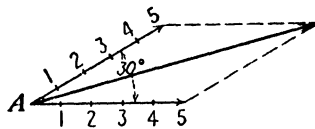

FIG. 5.

upon by two forces of 5 lb. each and acting at an angle of  $30^\circ$  to each other. To find the amount and direction of the resultant force, draw any two lines making an angle of  $30^\circ$  with each other. Then take some convenient scale, such as 1 in. equals 5 lb., and make each line 1 in. long. Now complete the parallelogram, and measure the length of the diagonal, or resultant force, in inches. It will be found to be about 1.92 in. long. But since 1 in. equals 5 lb., the value of the resulting force will be

$$1.92 \times 5 = 9.6 \text{ lb.}$$

Very often it is inconvenient to represent forces by vectors, and the determination of the resultant must be done by another method

involving the law of cosines and some mathematics. Referring to Fig. 4, from the law of cosines we get

$$(AC)^2 = (AB)^2 + (BC)^2 - 2(AB)(BC) \cos ABC$$

since

$$BC = AD$$

$$(AC)^2 = (AB)^2 + (AD)^2 - 2(AB)(AD) \cos ABC$$

But

$$\angle ABC = 180^\circ - \angle DAB$$

and

$$\cos ABC = \cos (180^\circ - DAB) = -\cos DAB$$

Then

$$(AC)^2 = (AB)^2 + (AD)^2 + 2(AB)(AD) \cos DAB$$

where  $AC$  is the resultant of the forces  $AB$  and  $AD$  and angle  $DAB$  is the angle between the two forces. Hence, we can write for any two forces,  $P$  and  $Q$ , with an angle  $A$  between them

$$R = \sqrt{P^2 + Q^2 + 2PQ \cos A}$$

where  $R$  is the resultant of the two forces  $P$  and  $Q$ .

In Fig. 6, each of the forces is equal to 5 lb., and the angle between them is  $30^\circ$ . Calculating the resultant,

$$\begin{aligned} R &= \sqrt{5^2 + 5^2 + 2 \times 5 \times 5 \times \cos 30^\circ} \\ &= \sqrt{25 + 25 + 43.30} = \sqrt{93.3} = 9.66 \text{ lb.} \end{aligned}$$

If the angle between these two forces were  $90^\circ$ , the resultant would be

$$\begin{aligned} R &= \sqrt{5^2 + 5^2 + 2 \times 5 \times 5 \times \cos 90^\circ} \\ &= \sqrt{5^2 + 5^2 + 0} = \sqrt{50} = 7.07 \text{ lb.} \end{aligned}$$

The direction of either of the resultants can be obtained by means of trigonometry. Where the angle between the forces differs from  $90^\circ$ , as in the case of the 9.66-lb. resultant shown in Fig. 6, angle  $ADC = 180^\circ - \text{angle } BAD$ ; then angle  $ADC = 180^\circ - 30^\circ = 150^\circ$ . Using triangle  $ACD$  and applying the law of sines,

$$\begin{aligned} \frac{\sin ADC}{AC} &= \frac{\sin CAD}{DC} \quad \text{where} \quad DC = AB \\ \frac{\sin 150^\circ}{9.66} &= \frac{\sin CAD}{5} \end{aligned}$$

Therefore

$$\sin CAD = \frac{5 \times 0.50000}{9.66} = 0.25880$$

$$CAD = 15^{\circ}'$$

In the case of the 7.07-lb. resultant shown in Fig. 7,

$$\cos COA = \frac{OA}{OC} = \frac{5}{7.07} = 0.7071 \quad \text{which is the cosine of } 45^{\circ}$$

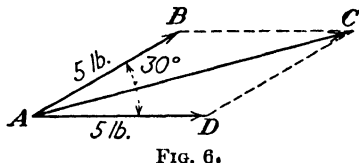

FIG. 6.

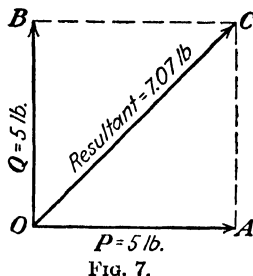

FIG. 7.

Therefore

$$\angle COA = 45^{\circ}$$

or we could say

$$OB = AC = 5 \text{ lb.}$$

Then

$$\tan COA = \frac{AC}{OA} = \frac{5}{5} = 1.0 \quad \text{which is the tangent of } 45^{\circ}$$

Therefore

$$\angle COA = 45^{\circ}$$

Although these problems have involved two components only, the principles apply equally well with forces having any number of components. To find the resultant of any number of forces, combine any two of them as above, and find their resultant; then combine this resultant with a third force, thus obtaining a second resultant. This second resultant may then be combined with a fourth force, etc., until all the forces have been used.

In Fig. 8, to find the final resultant of the forces  $AB$ ,  $AC$ ,  $AD$ , and  $AE$ , take any two of them, such as  $AB$  and  $AC$ , and find their resultant  $AM$ . Combine this resultant  $AM$  with the component  $AD$ , thus obtaining a new resultant  $AN$ . This new resultant  $AN$ , when combined with the component  $AE$ , will give  $AR$  as the final resultant of the four forces.

In Fig. 4, page 3, the resultant may be obtained in a slightly different manner. Draw the force  $AB$  horizontally to the right and of the correct length to represent the amount. From the end  $B$ , draw the second force  $BC$ , which is equal to  $AD$  in its correct direction and amount. Now connect the beginning  $A$  of the first force  $AB$  and the end  $C$  of the second force ( $BC = AD$ ). This vector corresponds to the diagonal of the parallelogram and represents the amount and direction of the resultant.

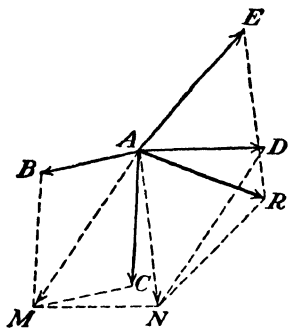

FIG. 8.

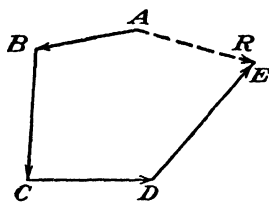

FIG. 9.

This process may be used to solve the resultant of any number of forces, the vector drawn from the beginning of the first force to the end of the last force giving the *amount* and *direction* of the resultant.

This method as applied to the problem of Fig. 8 would be as shown in Fig. 9.

Closing line, drawn from  $A$  to  $E$  = resultant.  $AR$

**Resolution of a Force.**—Resolution is the opposite of composition; that is, the resolution of a force is the process of finding two or more forces which will produce the same effect as a given force. If only two components are required, the process consists of finding the sides of a parallelogram whose diagonal represents the given force.

Let it be required to resolve a force of 30 lb. acting horizontally to the right into two forces, one of them acting vertically downward and the other at an angle of  $30^\circ$  above the horizontal.

Draw  $AB$ , Fig. 10, to some scale so as to represent 30 lb. acting to the right. Draw  $AC$  downward and  $AD$  at an angle of  $30^\circ$  above  $AB$ . Complete the parallelogram  $ADBC$ . Then the required component forces will be  $AC$  and  $AD$ .

It is very important to be able to resolve a force into two components with an angle of  $90^\circ$  between them. When the angle between the components is  $90^\circ$ , the components and the resultant form a right triangle, which may be solved very easily by trigonometry. As an example: If a force of 10 lb. is at an angle of  $30^\circ$  with a horizontal line, what are the horizontal and vertical components of the force? It will

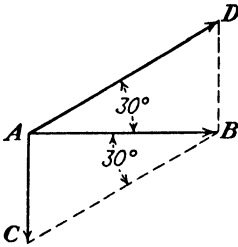

FIG. 10.

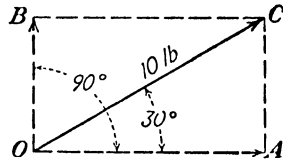

FIG. 11.

be seen (Fig. 11) that  $OB$  and  $AC$  are parallel and equal; hence if  $AC$  can be solved,  $OB$  will be known. Then in the right triangle  $OAC$

$$\sin 30^\circ = \frac{AC}{OC} \quad \text{where} \quad OC = 10 \text{ lb.}$$

$$\sin 30^\circ \times OC = AC$$

or

$$AC = 0.50000 \times 10 = 5 \text{ lb.} = OB$$

Then

$$OB = 5 \text{ lb.}$$

This is called the *vertical component* of the 10-lb. force, as it is at a right angle to the horizontal line  $OA$ .

Likewise

$$\cos 30^\circ = \frac{OA}{OC}$$

from which

$$\begin{aligned} OA &= OC \cos 30^\circ \\ &= 10 \times 0.86603 = 8.6603 \text{ lb.} \end{aligned}$$

which is called the *horizontal component* of the 10-lb. force.

The two components of any given force must be such that their resultant equals the given force, and the components must intersect on the line of action of the given force.

To check the above components,

$$\begin{aligned}(OC)^2 &= (OA)^2 + (OB)^2 \\ &= (8.66)^2 + (5.0)^2 = 75 + 25 = 100\end{aligned}$$

Then

$$OC = \sqrt{100} = 10 \text{ lb.}$$

and the components can be placed anywhere on the line of action of the 10-lb. force, for example, at  $O$ ,  $M$ , or  $N$ , as long as they intersect on the line  $RS$  (Fig. 12).

**Composition of Forces by Components.**—Let it be required to find the resultant of a system of three forces that meet at a single point

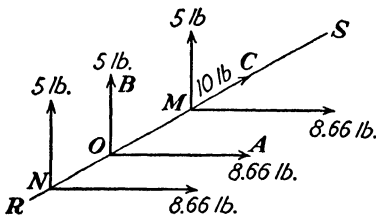

FIG. 12.

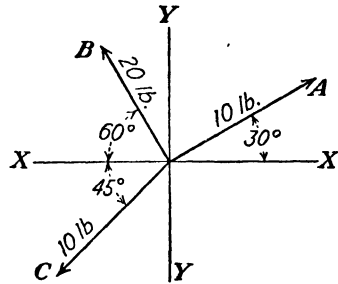

FIG. 13.

(Fig. 13). Each force is resolved into its horizontal and vertical components. All the horizontal components are combined into a resultant  $H$  and all the vertical components into a resultant  $V$ . Then the  $H$

Force	Horizontal components	Vertical components
$A$	$10 \cos 30^\circ = + 8.66 \text{ lb.}$	$10 \sin 30^\circ = + 5.00 \text{ lb.}$
$B$	$20 \cos 60^\circ = -10.00 \text{ lb.}$	$20 \sin 60^\circ = +17.32 \text{ lb.}$
$C$	$10 \cos 45^\circ = - 7.07 \text{ lb.}$	$10 \sin 45^\circ = - 7.07 \text{ lb.}$
	$H = - 8.41 \text{ lb.}$	$V = +15.25 \text{ lb.}$

and  $V$  resultants can be composed into a single force that represents the resultant of the entire system. It is necessary to note the directions of the components; those to the left are called negative because they are opposite to those to the right which are called positive. The components upward are positive since they are opposite to the downward (negative) components.

The original forces are equivalent therefore to two forces  $H$  and  $V$ , with an angle of  $90^\circ$  between them, as shown in Fig. 14. Determining the resultant of  $H$  and  $V$ ,

$$R = \sqrt{H^2 + V^2} = \sqrt{(-8.41)^2 + (+15.25)^2}$$

$$= \sqrt{70.73 + 232.56} = \sqrt{303.29}$$

$$R = 17.42 \text{ lb.}$$

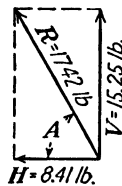

FIG. 14.

This method will be found to be much simpler than the method previously given, and is preferable in so far as the mathematics involved is shorter.

To determine the direction of the resultant, as in Fig. 14, it will be seen that

$$\tan A = \frac{V}{H} = \frac{15.25}{8.41} = 1.812$$

and

$$\text{angle } A = 61^\circ 08'$$

**Representation of Velocities.**—So far we have considered only forces that act at a point. However, the same graphical or mathematical methods may be used to solve problems in velocity; that is, a velocity of 10 ft. per sec. may be represented by a vector whose direction represents the direction of the moving point and whose length is 10 units on some convenient scale.

A little experience with problems concerning graphical representations of motion will serve to show the great importance it has to the subject of machine design. It is simple and accurate and often makes it possible to avoid long algebraic calculations.

**Moments and Couples.**—The *moment* of a force about a point in its plane is the *product* of the *force* and the *perpendicular distance* (called the *lever arm*) from the point to the line of action of the force. The point referred to in the definition is the intersection of an axis that is perpendicular to the plane containing the force and point with that plane. Many authors define the moment of a force as the product of

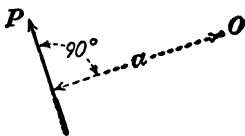

FIG. 15.

a force and the perpendicular distance from an axis, the axis being normal (or perpendicular) to the plane containing the force. Keeping this in mind, the text will make use of the phrase “about the point.”

In Fig. 15, the moment of force  $P$  about the point  $O$  is  $Pa$ , the product of the force  $P$  and the perpendicular lever arm  $a$ . An everyday example of a moment is the turning effect on an automobile steer-

ing wheel caused by the pull produced by the driver's arm times the radius of the wheel.

As a moment is the product of a force and the perpendicular lever arm, the units of a moment will be pounds (force) times feet (lever arm). Then we have the units of a moment equal to foot-pounds.

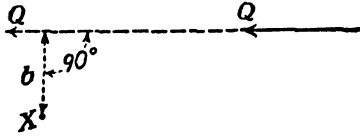

FIG. 16.

*Example.*—A force of 10 lb. acts at a distance of 2 ft. from a point.

What is the moment of the force about the point? The symbol for a moment is  $M$ . Hence

$$M = Pa = 10 \text{ lb.} \times 2 \text{ ft.} = 20 \text{ ft.-lb.}$$

The units of a moment can be foot-pounds or inch-pounds. Either length unit is acceptable but it must be carefully designated.

For the purpose of moments, any force may be considered to act anywhere on the line of action of the force. This principle is known

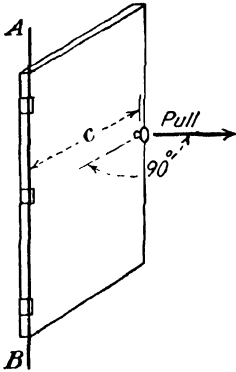

FIG. 17.

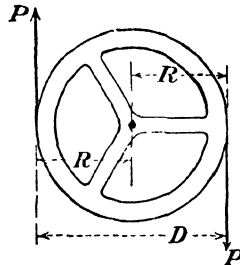

FIG. 18.

as the *transmissibility of a force*. Thus, the moment of the force  $Q$  about the point  $X$  (Fig. 16) is the product of  $Q$  and  $b$ , or  $Qb$ .

As previously stated, the moment of a force about a line or axis may be regarded as the moment of the force about a point; for example, when a door (Fig. 17) is opened by a pull applied horizontally, and at right angles to the door, the moment of the force is the product of the pull and the distance from the knob to the line of the hinges.

$$\text{Moment about } AB = \text{pull} \times c$$

When two forces are equal, opposite, and parallel, they form a *couple*.

*Example.*—The equal, parallel forces exerted by two hands being used to turn the steering wheel of an automobile form a couple. In this case (Fig. 18) one hand pushes and the other hand pulls, and the total moment (turning effect) is equal to the sum of the products of each pull times the distance from the center of the wheel to the circumference of the wheel.

$$\text{The moment of the couple} = PR + PR = 2PR$$

Since

$$2R = \text{the diameter } D$$

$$\text{The moment} = PD$$

Thus the moment of any couple about the turning axis (or *any* axis normal to the plane containing the couple) is equal to the product of one force and the perpendicular distance between the forces.

**Problems**

1. A body has two forces acting upon it, one of them a force of 60 lb. acting horizontally to the right and the other a force of 30 lb. acting vertically upward. Find the resultant force by both methods.
2. A train is moving due north at the rate of 88 ft. per sec. If a package is thrown from the train with an initial rate of 1,500 ft. per min. due west, what is the resultant velocity of the package as it leaves the window? In what direction, relative to the ground, will the package go? Solve graphically and mathematically.
3. The resultant force acting upon a body is 60 lb. This force was caused by the action of two forces, one of them acting to the right of the resultant and making an angle of 45° with it and the other acting to the left and making an angle of 30° with it. Find the two forces. Solve graphically.
4. Figure 19 shows a resultant force *R* and one component force *A*. Find the other component. Solve graphically.
5. Two forces act at an angle of 75°. If the resultant is 50 units and one of the forces is 35 units, find the other force. Solve graphically.

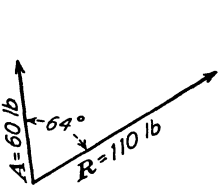

FIG. 19.

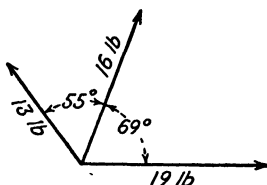

FIG. 20.

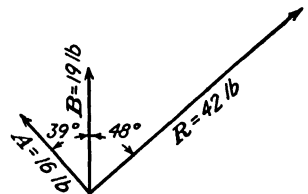

FIG. 21.

6. Find the resultant of the three forces shown in Fig. 20. Solve graphically.
7. Figure 21 shows a resultant *R* and two components *A* and *B*. Find the third component *C*. Solve graphically.
8. Four components have velocities of 40, 60, 100, and 120 ft. per min., respectively. The first acts horizontally to the right, the second vertically upward, the

third acts at an angle of  $60^\circ$  to the left of the second, and the fourth acts vertically downward. Find the resultant velocity graphically.

9. A force of 10 lb. acting horizontally to the right is to be resolved into two components, one of which acts along  $AB$  and the other along  $AC$  (Fig. 22). Solve the components mathematically

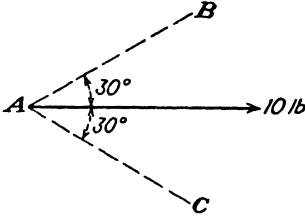

FIG. 22.

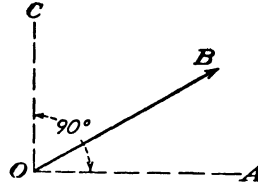

FIG. 23.

10. The resultant  $OB$  of  $OA$  and  $OC$  is 20 lb. (Fig. 23). If one component  $OA$  is 15 lb., what is the amount of the component  $OC$ , and what is the angle between  $OA$  and  $OB$ ? Solve mathematically.

11. Two forces, 20 lb. and 30 lb. respectively, make an angle of  $45^\circ$  with each other. What is the amount of the resultant force? What is its direction with respect to the 30-lb. force? Solve graphically and mathematically.

12. A man tightens the nut on a bolt by pulling with a force of 8 lb. on the end of a wrench 6 in. from the center of the bolt. What moment does he apply in tightening the nut?

13. A man pulls on a casting in a direction that makes an angle of  $20^\circ$  with the floor. If his pull is 55 lb., what is the amount of his pull parallel to the floor, and what amount is directed vertically?

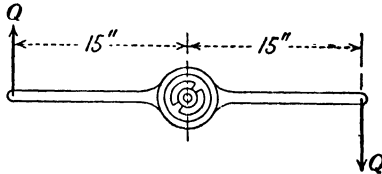

FIG. 24.

14. A double-ended die holder for cutting threads is 30 in. long. What equal forces,  $Q$  and  $Q$  (Fig. 24), must be applied to the ends of the holder to produce a moment of 45 ft.-lb.?

The following problems are to be solved mathematically:

15. What is the amount and direction of the resultant of the system of forces shown in Fig. 25? Solve by using components.

16. What is the moment of the couple (Fig. 26)?

17. What is the amount and direction of the resultant of the forces shown in Fig. 27. Use components.

18. A plumber uses a pipe wrench that has the equivalent of a 2-ft. lever arm. In tightening a pipe connection, he uses a 35-lb. pull. What moment does he apply to the connection?

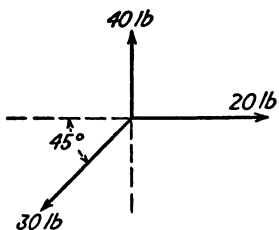

FIG. 25.

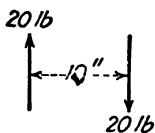

FIG. 26.

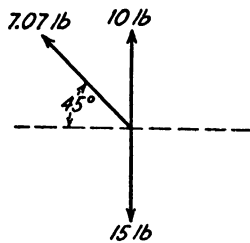

FIG. 27.

19. What is the algebraic sum of the moments of the forces  $R$  and  $S$  about the axis  $O$  (Fig. 28)?

20. Solve problem 8 mathematically, using components.

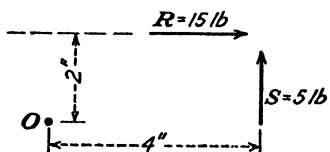

FIG. 28.

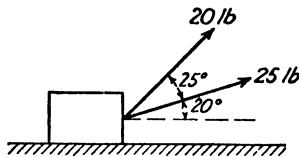

FIG. 29.

21. A body resting on a horizontal surface is pulled horizontally by the two forces shown in Fig. 29. What single horizontal force will give an equivalent horizontal pull?

## CHAPTER II

### EQUILIBRIUM OF FORCES IN ONE PLANE

When a system of forces acting on a body is balanced, the system is said to be in equilibrium; that is, the system of forces produces neither translatory motion (in a straight line) nor rotary motion. In such a system of forces, the resultant is zero, and consequently the  $H$  and  $V$  equations are separately equal to zero. Also, since there is no tendency of the body to rotate, the  $M$  (moment) equation is equal to zero.

**Concurrent Forces.**—When the lines of action of a number of forces meet at a common point, the forces are said to be concurrent. A

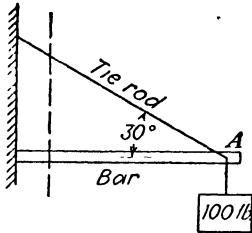

FIG. 30.

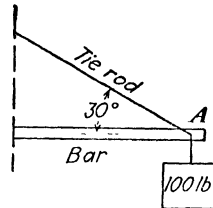

FIG. 31.

simple bracket crane, Fig. 30, is an example of such a system of forces in equilibrium, the forces at point  $A$  being concurrent. *In any structure in equilibrium, any part of the structure may be taken out as a free body in equilibrium under the action of the forces applied to that part.* Thus, in Fig. 31, the portion of the crane to the right of the dashed line is considered as a free body under the action of the force in the tie rod, of the force in the bar, and of the 100-lb. load.

The amounts of the forces in the tie rod  $T$  and in the bar  $B$  can be solved by use of the  $H$  and  $V$  equations. In order to write these equations correctly, it is necessary to assume the directions of the forces in these members, and therefore arrows will be placed on the members  $T$  and  $B$ , both being directed away from the point of concurrency  $A$ . Then, if the result of the mathematical solution of a

force is positive, the assumed direction is correct; if the sign of the result is negative, the assumed direction is incorrect. By following this procedure, it will be possible to tell that a part of a structure is being stretched or (as we say) is in *tension* if a positive answer results; if a negative answer results, the part of the structure is being shortened, or is in *compression*. In Fig. 32, with the arrows directed away from point  $A$ , write the  $H$  and  $V$  equations of equilibrium.

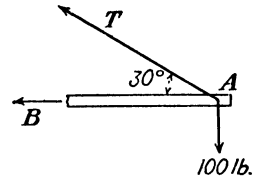

FIG. 32.

$$\begin{aligned} H &= -T \cos 30^\circ - B = 0 \\ V &= +T \sin 30^\circ - 100 \text{ lb.} = 0 \end{aligned}$$

From  $V$

$$T \sin 30^\circ = 100 \text{ lb.}$$

$$T = \frac{100}{\sin 30^\circ} = +200 \text{ lb. (tension)}$$

Substituting in  $H$ ,

$$\begin{aligned} -(200) \cos 30^\circ - B &= 0 \\ B &= -200 \cos 30^\circ = -173.2 \text{ lb. (compression)} \end{aligned}$$

In Fig. 33, a rope is attached to two posts 10 ft. apart. A weight of 200 lb. is hung from the rope 4 ft. from one of the posts. The rope sags 2 ft. Find the pull in each part,  $AB$  and  $BC$ , of the rope.

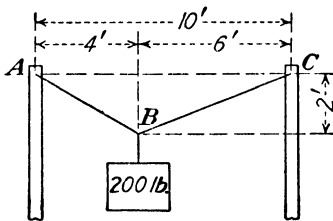

FIG. 33.

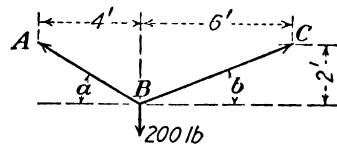

FIG. 34.

Draw the free body diagram as shown in Fig. 34, and assume the arrows point away from  $B$ ; that is, assume each rope pulls from the point  $B$ .

Calculating the lengths  $AB$  and  $BC$ ,

$$\begin{aligned} AB &= \sqrt{4^2 + 2^2} = \sqrt{20} = 4.47 \text{ ft.} \\ BC &= \sqrt{6^2 + 2^2} = \sqrt{40} = 6.32 \text{ ft.} \end{aligned}$$

Writing the  $H$  and  $V$  equations,

$$H = -A \cos a + C \cos b = 0$$

$$V = +A \sin a + C \sin b - 200 \text{ lb.} = 0$$

and

$$H = -\frac{4}{4.47} A + \frac{6}{6.32} C = 0$$

$$V = +\frac{2}{4.47} A + \frac{2}{6.32} C - 200 = 0$$

Solving simultaneously,

$$C = +252.8 \text{ lb. (tension)}$$

$$A = +268.2 \text{ lb. (tension)}$$

The derrick, Fig. 35, is used to raise a weight of 1,000 lb., as shown. By means of the horizontal  $H$  and vertical  $V$  resolution equations, solve the amount of the forces in  $AC$  and  $BC$ .

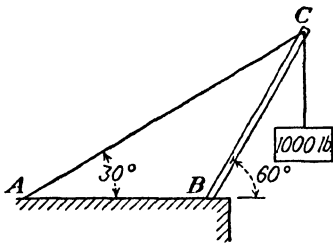

FIG. 35.

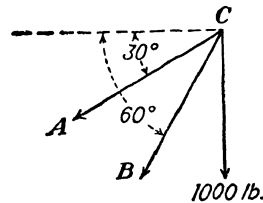

FIG. 36.

With the point of concurrency  $C$  as a free body, Fig. 36, write the  $H$  and  $V$  equations.

$$H = -A \cos 30^\circ - B \cos 60^\circ = 0$$

$$V = -A \sin 30^\circ - B \sin 60^\circ - 1,000 = 0$$

Then

$$-0.866A - 0.5B = 0 \quad (1)$$

$$-0.5A - 0.866B = 1,000 \quad (2)$$

Multiplying Eq. (1) by 0.5 and Eq. (2) by 0.866

$$-0.433A - 0.25B = 0 \quad (3)$$

$$-0.433A - 0.75B = 866 \quad (4)$$

Subtracting Eq. (3) from Eq. (4)

$$-0.433A - 0.75B = 866$$

$$-0.433A - 0.25B = 0$$

$$\hline -0.5B = 866$$

$$B = 1,732 \text{ lb.}$$

Substituting in Eq. (1) to solve  $A$

$$\begin{aligned} -0.866A - 0.5(-1,732) &= 0 \\ -0.866A + 866 &= 0 \\ A &= +1,000 \text{ lb.} \end{aligned}$$

If three or more forces in the same plane are concurrent, the forces may be solved graphically by representing them as the sides of a

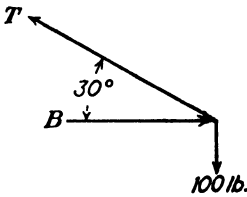

FIG. 37.

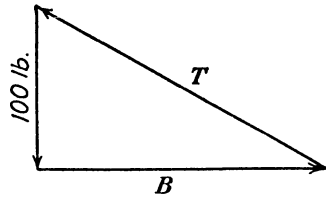

FIG. 38.

triangle or polygon parallel, respectively, to the forces. In Fig. 37, the forces  $B$  and  $T$  of the bracket crane shown in Fig. 30 are to be calculated graphically. Lay off the known force (100 lb.) in a vertical direction to some scale, as shown in Fig. 38. Then two lines drawn from the ends of the 100-lb. force, parallel to the two unknown forces  $B$  and  $T$ , will complete the force triangle. As the arrows must follow each other, place arrows on  $B$  and  $T$  to follow continuously around the

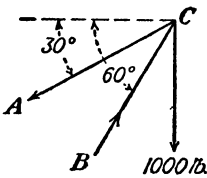

FIG. 39.

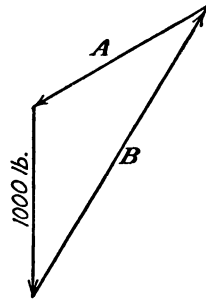

FIG. 40.

triangle in a direction determined by the known (100-lb.) force. Thus the arrow on  $B$  is to the right, and the arrow on  $T$  is up to the left. Then scale the lengths  $B$  and  $T$  in Fig. 38, and these will be the amounts of  $B$  and  $T$ . Also transfer the arrows to the original free body sketch, Fig. 37. By inspection, the arrow on  $B$  points toward the point of concurrency, thereby denoting compression, and the arrow on  $T$  points away from the point of concurrency, thereby denoting tension.

Using Fig. 35 as an illustrative example, from the free body sketch, Fig. 39, construct the force triangle, Fig. 40.

Scale the forces  $B$  and  $A$  on Fig. 40, and transfer the arrows from Fig. 40 to Fig. 39. The arrow on  $A$ , Fig. 39, points away from point  $C$ , and the force is tension. The arrow on  $B$  points toward point  $C$ , and the force is compression. Note that the kind of force in the members  $A$  and  $B$  agree with the results of the mathematical solution for the same problem.

**Resultants of Parallel Forces in One Plane.**—Let it be required to determine the amount and the location of the resultant of a system of parallel forces in one plane, given the system of forces shown in Fig. 41. The amount of the resultant must equal the algebraic sum of the forces, or  $R = P_1 + P_2 - P_3 + P_4$ , which is an application of the  $V$

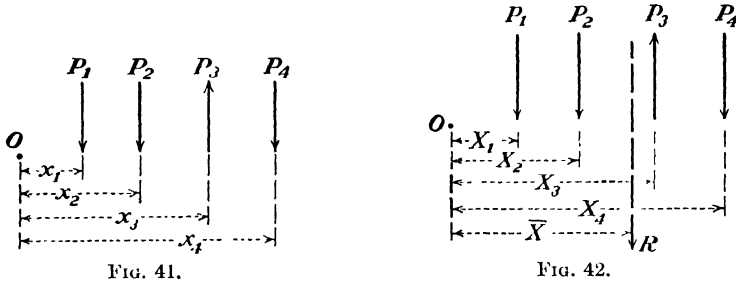

equation. Since this system is *not* in equilibrium, the equation is not equal to zero, and  $R$  becomes the algebraic sum of the four forces. It was previously shown that

$$R = \sqrt{H^2 + V^2}$$

but since

$$H = 0, \quad R = \sqrt{V^2} = V$$

In order to satisfy the definition of a resultant, the resultant force must produce the same moment about any point as the sum of the moments of the separate forces. Using  $O$  as the center of moments, and letting  $\bar{X}$  be the lever arm<sup>1</sup> of the resultant, as shown in Fig. 42, then

$$R\bar{X} = P_1X_1 + P_2X_2 - P_3X_3 + P_4X_4$$

and

$$\bar{X} = \frac{P_1X_1 + P_2X_2 - P_3X_3 + P_4X_4}{R}$$

or

$$\bar{X} = \frac{P_1X_1 + P_2X_2 - P_3X_3 + P_4X_4}{P_1 + P_2 - P_3 + P_4}$$

It should be noted that clockwise moments will be called positive and counterclockwise moments will be called negative.

*Example.*—Locate the resultant of the following system of forces from the point  $O$ , Fig. 43.

$$\begin{aligned}
 R &= 10 + 20 - 4 - 6 = 20 \text{ lb. (downward)} \\
 \bar{X} &= \frac{10 \times 2 + 20 \times 6 - 4 \times 9 - 6 \times 12}{20} \\
 &= \frac{20 + 120 - 36 - 72}{20} = \frac{32}{20} = 1.6 \text{ ft.}
 \end{aligned}$$

*Example.*—In the following example, note that the resultant is located to the left of the center of moments. What is the amount and

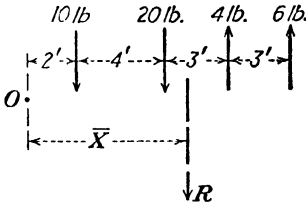

FIG. 43.

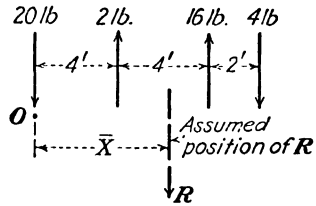

FIG. 44.

where is the resultant of the following system of parallel forces (Fig. 44)?

$$\begin{aligned}
 R &= 20 - 2 - 16 + 4 = 6 \text{ lb. (downward)} \\
 \bar{X} &= \frac{20 \times 0 - 2 \times 4 - 16 \times 8 + 4 \times 10}{6} \\
 &= \frac{0 - 8 - 128 + 40}{6} = -\frac{96}{6} = -16 \text{ ft.}
 \end{aligned}$$

The sum of the moments of the four forces is 96 ft.-lb., counterclockwise about  $O$ . Hence, when  $R$  is downward, it must be located to the left of  $O$  to produce counterclockwise moment. Therefore  $R = 6$  lb. downward 16 ft. to the left of point  $O$ .

**Problems**

22. A weight of 240 lb. is hung from a rope as shown in Fig. 45. What pull is exerted in  $AB$  and  $BC$ ?  $AB = 13$  ft. Points  $A$  and  $C$  are on the same level.

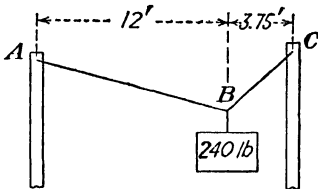

FIG. 45.

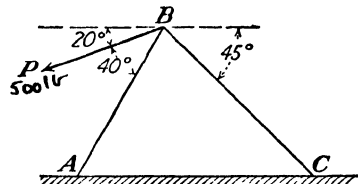

FIG. 46.

23. When the force  $P = 500$  lb., in Fig. 46, what is the amount of stress in member  $AB$ ? in member  $BC$ ? What kind of stress is in each member?

24. In Fig. 47, three parallel forces are to be replaced by a single force having the same effect. What is the amount of the single force? What is its location from the left force? 600, 6.33'

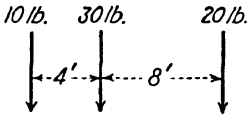

FIG. 47.

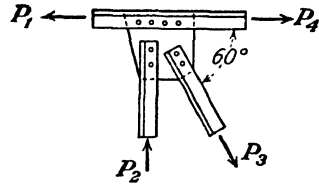

FIG. 48.

25. Figure 48 shows the forces that act at a panel point of a bridge truss. When  $P_1 = 32,000$  lb. and  $P_2 = 18,000$  lb., what are the values of  $P_3$  and  $P_4$ ?

26. Figure 49 shows a simple frame attached to a wall. If  $P = 450$  lb., what are the amounts of the forces in  $AB$  and  $BC$ ?

27. A weight of 200 lb. is suspended from a ceiling by three ropes in the same vertical plane. The first rope makes an angle of  $30^\circ$  to the left of the vertical and has a tension of 100 lb. The second rope is vertical, and the third rope pulls horizontally to the right. Find the tensions in the second and third ropes.

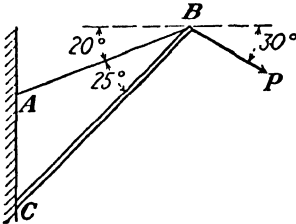

FIG. 49.

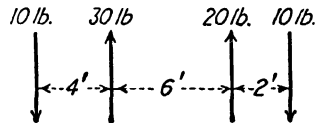

FIG. 50.

28. Locate and give the amount of the resultant of the system of parallel forces shown in Fig. 50.

29. In Fig. 51, what are the amounts of the stresses in  $RS$  and  $ST$ ? What kind of stress is in each member? Solve both mathematically and graphically.

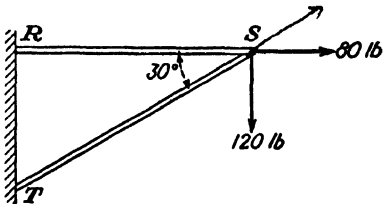

FIG. 51.

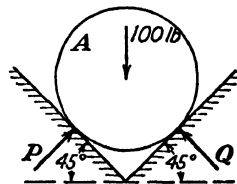

FIG. 52.

30. What forces do the sides of the trough exert on cylinder  $A$ , which weighs 100 lb.? Note that the reactions  $P$  and  $Q$  of the trough on the cylinder are perpendicular to the sides of the trough (Fig. 52).

31. Body  $B$  in Fig. 53 weighs 40 lb. When the force  $P$  is sufficient to cause the supporting rope  $R$  to make an angle of  $70^\circ$  with the ceiling, what force  $P$  is necessary, and what is the amount of force  $R$ ?

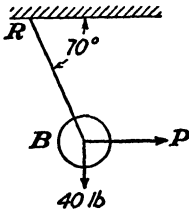

FIG. 53.

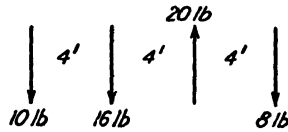

FIG. 54.

32. What is the amount and location of the resultant force of the parallel system of forces (Fig. 54)?

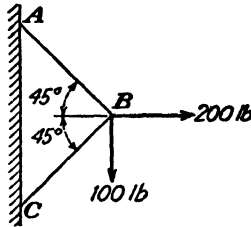

FIG. 55.

33. In Fig. 55, what are the amounts of the stresses in  $AB$  and  $BC$ ? Solve mathematically.

**Equilibrium of Parallel Forces in One Plane.**—When a system of parallel forces is in equilibrium, the resultant force is equal to zero,

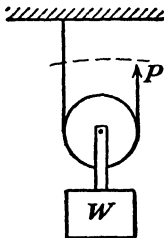

FIG. 56.

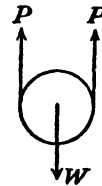

FIG. 57.

and hence  $H$  and  $V$  are equal to zero. A simple pulley system will illustrate this principle (Fig. 56). By the free body method, and because of the fact that the pull in any continuous rope is constant where the pulley friction is negligible, the pulley can be considered in equilibrium under the action of the three forces as shown in Fig. 57.

By  $V = 0$

$$\begin{aligned} +P + P - W &= 0 \\ 2P &= W \\ P &= \frac{W}{2} \end{aligned}$$

Figure 58 shows a beam which has the force  $P$  acting down and which is supported by the reactions  $R_1$  and  $R_2$ . This beam may be considered as a bridge, with the force  $P$  representing some weight on it and the reaction representing the supports.

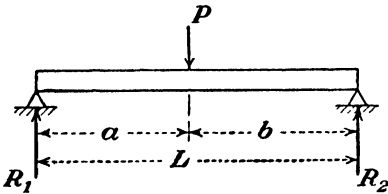

FIG. 58.

Now let us consider the support  $R_1$  as an axis of rotation. The force  $P$  will tend to swing the beam in a clockwise direction about  $R_1$  while the support  $R_2$  is acting up, and will tend to swing the beam in a counterclockwise direction about  $R_1$ . But if the beam is part of a bridge or some other structure, naturally it will be at rest, or as we generally say, in equilibrium. Hence, these turning effects must just balance each other, which means that the clockwise turning effect must just equal the counterclockwise turning effect, or that the sum of the moments about any axis equals zero ( $M = 0$ ).

On a preceding page we learned that the moment of a force (or the turning effect) about any point is equal to the product of the force and its perpendicular distance to the point or axis of rotation. Hence, from Fig. 58, the moment of the force  $P$  about  $R_1$  will equal  $P$  times  $a$ , or  $Pa$ . Likewise, the moment of the force  $R_2$  about  $R_1$  will equal  $R_2$  times  $L$ , or  $R_2L$ . But since their algebraic sum may equal zero, then

$$+Pa - R_2L = 0$$

If  $R_2$  is considered as the axis of rotation,  $Pb$  will be the moment of the force  $P$  about  $R_2$ , and  $R_1L$  will be the moment of the force  $R_1$  about  $R_2$ . Hence,

$$R_1L - Pb = 0$$

**Reactions.**—Generally, the loads acting down on a beam are known. If they are not known, they should be calculated before proceeding further in the design of the beam. As soon as these loads are obtained, the reactions, or supporting forces, can be calculated from the principle of moments.

Figure 59 shows a beam 20 ft. long with a force  $P$  of 200 lb. acting down. The reactions are  $R_1$  and  $R_2$ , and the force  $P$  acts 12 ft. from  $R_1$  and 8 ft. from  $R_2$ . Now let us take moments about  $R_1$ .

The moment of the force  $P$  about  $R_1$  will be

$$+200 \times 12$$

likewise, the moment of  $R_2$  about  $R_1$  will be

$$-R_2 \times 20$$

As the sum of the moments about any axis must equal zero, then

$$\begin{aligned} 200 \times 12 - R_2 \times 20 &= 0 \\ 20R_2 &= 2,400 \\ R_2 &= 120 \text{ lb.} \end{aligned}$$

Likewise, to find the value of  $R_1$ , we take moments about  $R_2$ , from which is obtained

$$\begin{aligned} -200 \times 8 + R_1 \times 20 &= 0 \\ 20R_1 &= 1,600 \\ R_1 &= 80 \text{ lb.} \end{aligned}$$

In order for the beam to be in equilibrium, the forces acting downward must be equal to the reactions acting upward, or  $V = 0$ . That is,

$$R_1 + R_2 - P = 0$$

and

$$R_1 + R_2 = P$$

In this problem

$$120 + 80 = 200$$

which checks the reactions.

**Uniformly Distributed Loads.**—In the problem of Fig. 59, the weight of the beam itself was not figured as a force acting down. This weight will be an equally distributed load throughout the entire length of the beam. Moreover, a beam often supports a uniform load of a similar nature, for example, when it is supporting a wall. Such loads, therefore, are called *uniform loads* and are expressed in pounds per foot of length. Figure 60 illustrates a uniform load acting on a beam.

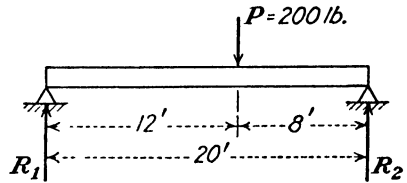

FIG. 59.

This uniform load may be considered as an infinite number of small forces acting down, each with its own moment arm (its own perpendicular distance from any axis of rotation). However, the combined effect of all these forces will be the same as one force which is equivalent to their total amount and which is acting down at the center. Thus, in Fig. 60, if the beam is 16 ft. long and the uniform load is 80 lb. per ft., the total weight or load will be  $16 \times 80$ , or 1,280 lb., which may be considered as acting down at the middle of the uniform loading.

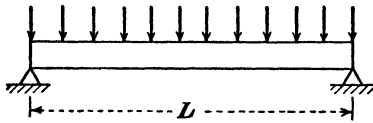

FIG. 60.

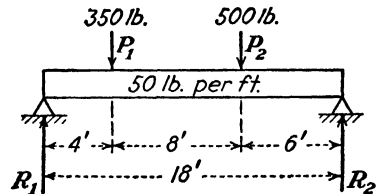

FIG. 61.

Figure 61 shows a beam with forces  $P_1$  and  $P_2$  acting down, and in addition to these it is carrying a uniform load of 50 lb. per ft. Hence, to take moments and to find the reactions, the forces  $P_1$  and  $P_2$  and the uniform load must all be considered as acting down.

In this case the uniform load will be  $18 \times 50$ , or 900 lb. Hence, taking moments about  $R_1$ , we get

$$350 \times 4 + 900 \times 9 + 500 \times 12 - R_2 \times 18 = 0$$

from which

$$R_2 = 861 \text{ lb.}$$

Likewise, taking moments about  $R_2$ ,

$$- 500 \times 6 - 900 \times 9 - 350 \times 14 + R_1 \times 18 = 0$$

from which

$$R_1 = 889 \text{ lb.}$$

Checking,

$$\begin{aligned} R_1 + R_2 &= P_1 + P_2 + \text{total weight of beam} \\ 889 + 861 &= 350 + 500 + 18 \times 50 \\ 1,750 &= 1,750 \end{aligned}$$

**Reactions for Cantilever Beams.**—As the wall furnishes the only support for a cantilever beam, it follows directly that the upward reaction  $R$  at the wall must equal the sum of the downward forces (loads). ( $V = 0$ .)

Hence, in Fig. 62,

$$R - P = 0$$

Then

$$R = 1,000 \text{ lb.}$$

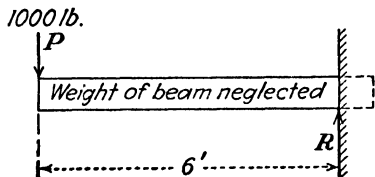

FIG. 62.

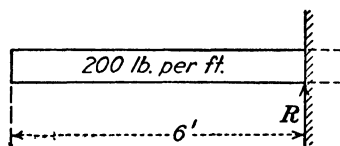

FIG. 63.

In Fig. 63, the cantilever beam supports a uniform load of 200 lb. per ft., which includes its own weight. The wall, offering the only support, must provide a reaction equal to the total downward force (total uniform load). Hence,

$$R - \text{total uniform load} = 0$$

$$R = 200 \times 6 = 1,200 \text{ lb.}$$

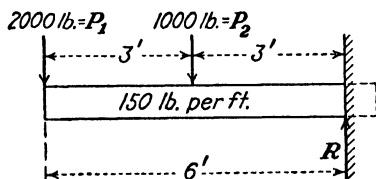

FIG. 64.

The cantilever beam shown in Fig. 64 supports a uniform load in addition to two concentrated loads  $P_1$  and  $P_2$ . The total reaction  $R$  will equal the sum of the downward forces, or

$$R - P_1 - P_2 - \text{total uniform load} = 0$$

$$R = 2,000 + 1,000 + 150 \times 6$$

$$R = 3,900 \text{ lb.}$$

Problems

34. In Fig. 65, what is the moment of the force  $P$  about  $R_1$ ? <sup>3409' lb</sup> What is the moment of the force  $P$  about  $R_2$ ? What is the moment of  $R_2$  about  $R_1$ ? Set up the moment equations for solving the reactions, and then complete the solutions.

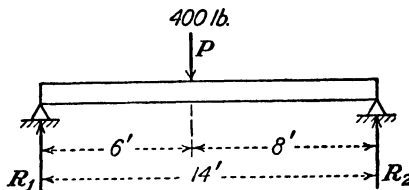

FIG. 65.

35. If the force  $P$  in Fig. 59 were 650 lb. instead of 200 lb., what would be the reactions?

36. A beam 12 ft. long carries a uniformly distributed load of 120 lb. per ft. What are the reactions?

37. In problem 36, assume that another force  $P$ , of 500 lb., acts down at the middle of the beam. What are the reactions now?

38. Figure 66 shows a beam with two forces and a uniform load. Find the reactions.

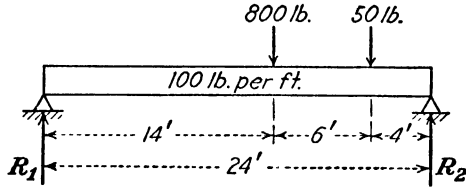

FIG. 66.

39. A cantilever beam is shown in Fig. 67. What is the amount of the reaction  $R$ ?

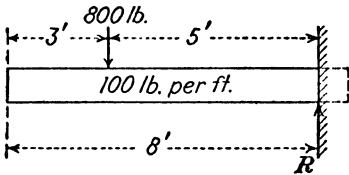

FIG. 67.

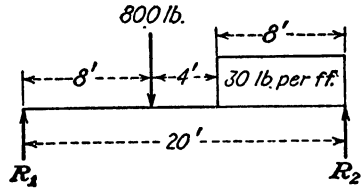

FIG. 68.

40. Solve the reactions  $R_1$  and  $R_2$  (Fig. 68).

41. Solve the reactions  $R_1$  and  $R_2$  (Fig. 69).

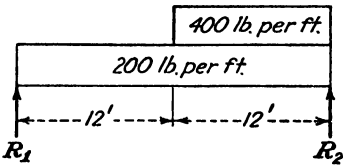

FIG. 69.

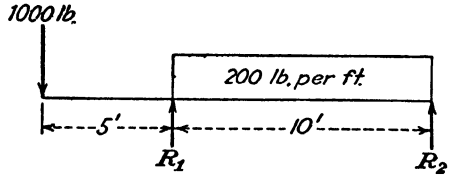

FIG. 70.

42. Solve the reactions  $R_1$  and  $R_2$  (Fig. 70).

## CHAPTER III

### SIMPLE MACHINES

**Types of Machines.**—All machines consist of one or more of six fundamental types, namely, the lever, pulley, wheel and axle, inclined plane, wedge, and screw. In general, however, all these are modified forms of either the lever or the inclined plane.

The lever is a rigid bar, either straight or curved, that turns about a fixed axis called the *fulcrum*. This is probably the simplest, as well as the most used, type of machine. Among its numerous applications are shears, pliers, cranks, and pinch bars.

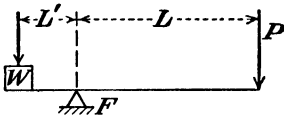

FIG. 71.

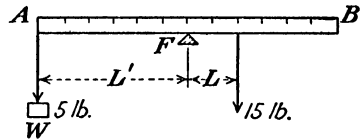

FIG. 72.

Figure 71 shows a lever of the simplest form. Here  $W$  represents a weight,  $F$  represents the fulcrum of the lever, and  $P$  represents a given force that is tending to raise the weight  $W$ . It is quite evident that the position of the fulcrum  $F$  with respect to the weight  $W$  and the force  $P$  will determine the tendency that  $P$  will have to raise  $W$ ; that is, if  $F$  is close to  $W$ , a comparatively small force  $P$  will raise  $W$ , but if  $F$  is placed near  $P$ , a much larger force  $P$  must be applied to raise the weight.

Let the yardstick, Fig. 72, be balanced by being supported in the middle. Then hang a mass of 5 lb. at one end of it. Now if, by experiment, a point be found on the other side of the bar where a force of 15 lb. must be applied in order to balance the stick again, this point will be found to be 6 in. from the fulcrum.

It will be seen that the moment of the weight of 5 lb. about the fulcrum must be equal to the moment of the force of 15 lb. about the same point (fulcrum). Or the product of the 5-lb. weight and the 18-in. lever arm, which is 90 in.-lb., equals the product of the 15-lb. force and its 6-in. lever arm, or 90 in.-lb. Furthermore, the 5-lb. weight tends to cause the yardstick to rotate (turn) counter-

clockwise about the fulcrum, while the 15-lb. force tends to cause the yardstick to rotate clockwise about the fulcrum. Hence, when the lever is balanced, the *counterclockwise moment* on *any lever* must be equal to the *clockwise moment*. That is,

$$\begin{aligned} 5 \text{ lb.} \times 18 \text{ in.} &= 15 \text{ lb.} \times 6 \text{ in.} \\ 90 \text{ in.-lb.} &= 90 \text{ in.-lb.} \end{aligned}$$

Referring to Fig. 71, that part of the lever marked  $L$ , which extends between the fulcrum  $F$  and the force  $P$ , is called the *force arm*; and that part  $L'$ , which extends between the fulcrum and the weight  $W$ , is called the *weight arm*. The condition for any lever to be in balance is, therefore, that

$$P \times L = W \times L' \quad \text{or} \quad PL = WL'$$

This shows that four items are necessary for a complete knowledge of a lever: the force, the weight, the force arm, and the weight arm. If any three of these are known, the fourth may be determined easily by representing it by a letter and solving the resulting equation.

**Problem.**—The weight arm of a lever is 8 in. long, and the force arm is 28 in. long. How great a weight can be raised by a force of 30 lb. acting at the end of the force arm?

**Solution.**—In the equation  $PL = WL'$ , let the required weight be represented by the letter  $W$ . Since  $L = 28$  in.,  $P = 30$  lb., and  $L' = 8$  in.,

$$30 \times 28 = 8 \times W$$

from which

$$8W = 840$$

or

$$W = \frac{840}{8} = 105 \text{ lb. Answer}$$

**Three Classes of Levers.**—Levers are divided into three general classes, depending on the respective positions of the weight, the force,

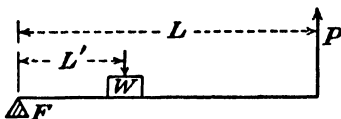

FIG. 73.

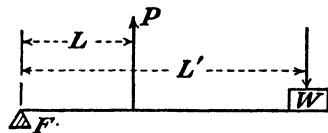

FIG. 74.

and the fulcrum. A lever in which the fulcrum is placed between the weight and the force, as was the case in Fig. 72, is a lever of the first class. If, however, the weight is placed between the fulcrum and the force, as in Fig. 73, it is known as a lever of the second class. Again, if the force  $P$  is placed between the fulcrum and the weight, as in

Fig. 74, there results a lever of the third class. The relation between force, weight, force arm, and weight arm holds true for each class of levers, that is, in every case  $PL = WL'$ .

The laws that govern the straight lever also apply to the bent lever. In the case of the bent lever, however, great care must be taken to determine the true length of the lever arms. In every case the true length of the arms will be the perpendicular distance between the fulcrum and the direction line of the

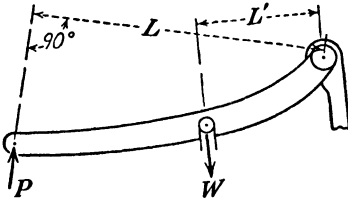

FIG. 75.

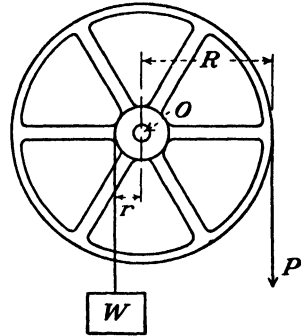

FIG. 76.

force or weight. Thus, in Fig. 75,  $L$  is the lever arm for the acting force  $P$ , and  $L'$  is the arm for the reacting weight  $W$ .

In this figure, if  $L = 30$  in.,  $L' = 8$  in., and  $P = 60$  lb., then, to find the weight that can be raised,

$$PL = WL'$$

or

$$60 \times 30 = W \times 8$$

$$W = 225 \text{ lb. Answer}$$

A simple machine that is based on the lever principle is called the *wheel and axle*. By wrapping ropes around two different-sized drums of radii  $R$  and  $r$  (Fig. 76), we find that the pull  $P$  necessary to raise the weight  $W$  can be determined. The drums are fastened together on a shaft  $O$  so that the center of the shaft becomes the fulcrum, or axis of rotation. Then, by the principle of moments, the moment of the pull  $PR$  equals the moment of the weight  $Wr$ , or

$$PR = Wr$$

In the above figure, let  $W = \frac{1}{2}$  ton;  $r = 3$  in.; and  $R = 18$  in. What pull  $P$  is required to lift the weight?

$$\frac{1}{2} \text{ ton} = \frac{1}{2} \times 2,000 \text{ lb.} = 1,000 \text{ lb.}$$

Therefore

$$P \times 18 = 1,000 \times 3$$

$$P = 166\frac{2}{3} \text{ lb.}$$

The wheel and axle furnish the basic idea of a line shaft on which there are several pulleys, one belted to an engine or motor, and the others belted to machines. Figure 77 shows one pulley (driven) as being belted to a machine and a second pulley (driver) as being belted to a motor. The moment of the motor pull about the axis of the shaft must be equal to the moment of the machine pull about the same axis. Hence,  $PR = Qr$ , or if a second machine were driven from the same shaft by a belt, from a pulley of radius  $r'$ , with a pull  $S$ , then

$$PR = Qr + Sr'$$

Actually, there are always some pulls in the slack sides of the belts. In Fig. 77, as well as in the example that follows, the slack side pulls

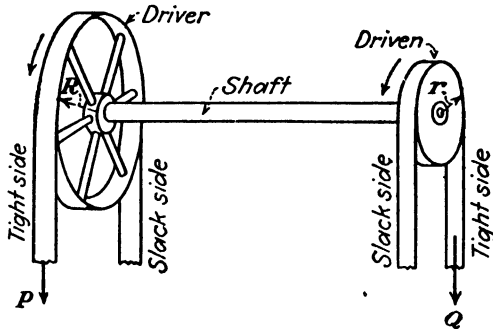

FIG. 77.

are assumed to be zero. As an example, a motor puts a pull of 140 lb. into a belt passing around a pulley 18 in. in diameter. Two machines are to be driven through the pulley shaft, the pulleys for the machines having diameters of 6 in. and 8 in. If both machines require the same belt pull, what is the amount of this pull? The moment of the motor pull about this axis of the shaft is

$$140 \text{ lb.} \times 9 \text{ in.} = 1,260 \text{ in.-lb.}$$

The machine-belt moment about the center of the shaft is

$$Q \times 3 \text{ in.} + S \times 4 \text{ in.} \quad \text{but } Q = S$$

Then

$$3Q + 4Q = 1,260 \text{ in.-lb.}$$

$$7Q = 1,260 \text{ in.-lb.}$$

$$Q = 180 \text{ lb.} \quad \text{in belt to each}$$

The object of a machine is to change the direction and magnitude of an available force  $P$  so as to make it more useful in overcoming a

resistance  $Q$ . Then, the ratio  $\frac{Q}{P}$  of the resistance to the given force is called the *mechanical advantage*.

With reference to the lever problem given on page 28, a weight  $W$  is 8 in. from the fulcrum and is to be raised by a force of 30 lb. that is 28 in. from the fulcrum. By the principle of moments about the fulcrum

$$PL = WL'$$

then

$$30 \text{ lb.} \times 28 \text{ in.} = W \times 8 \text{ in.} \quad \text{or} \quad W = 105 \text{ lb.} \quad (1)$$

As  $W$  is the resistance and  $P$  is the available force, the mechanical advantage is the ratio  $\frac{W}{P} = \frac{105}{30} = 3.5$ . From Eq. (1), it will be noted that

$$\frac{W}{P} = \frac{28}{8} = 3.5$$

Hence, the mechanical advantage of a lever is either the ratio

$$\frac{\text{Resisting force}}{\text{Available force}} \text{ or the } \frac{\text{lever arm of available force}}{\text{lever arm of resisting force}}$$

### Problems

**43.** A lever of the first class is 6 ft. long. Where should the fulcrum be placed so that a force of 80 lb. acting at one end of the lever will lift a weight of 300 lb. hanging at the other end of the lever? What is the mechanical advantage of this lever?

**44.** In Fig. 75, if the force arm is 4 ft. and the weight arm is 16 in., what force  $P$  will be required to raise a weight of 300 lb.? What is the mechanical advantage?

**45.** In a lever of the second class, where should a weight of 800 lb. be placed so that it can just be lifted by a force of 125 lb. acting 10 ft. from the fulcrum. What is the mechanical advantage?

**46.** In a lever of the third class, where must a force of 50 lb. be applied so as to raise a weight of 16 lb. hanging 7 ft. from the fulcrum?

**47.** A claw hammer is being used to pull a nail. When a  $2\frac{1}{2}$ -lb. pull is applied to the handle, and the hammer turns about the point  $O$ , what force is applied to the nail? What is the mechanical advantage of this hammer (see Fig. 78)?

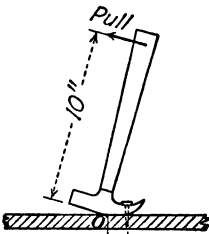

FIG. 78.

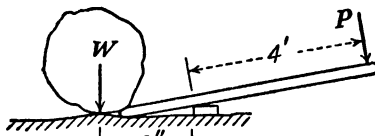

FIG. 79.

48. A crowbar is being used to move a rock as shown in Fig. 79. A man pushes on the end of the bar with a force equal to four-fifths of his weight. What weight stone can be moved if the man weighs 160 lb.? What is the mechanical advantage of this crowbar?

49. A rope to which a pull of 40 lb. is applied is wrapped around a 24-in.-diameter drum. Fastened on the same axle is a smaller drum about which a rope is wound and tied to a 200-lb. weight, which is to be lifted. What is the mechanical advantage of the machine. What is the diameter of the smaller drum?

50. Two pulleys, 30 in. in diameter and 6 in. in diameter, respectively, are keyed to a shaft. If the belt pull from the larger pulley is 50 lb., what is the belt pull from the smaller pulley? What is the mechanical advantage?

51. A windlass consists of a drum 12 in. in diameter and a lever 4 ft. long, fastened on the same axle. When a push of 50 lb. is applied to the end of the lever, what pull is exerted in a rope wound around the drum (Fig. 80)?

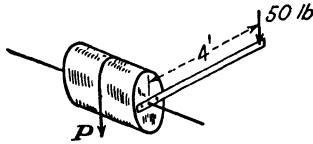

FIG. 80.

52. A line shaft is driven by a belt around a 2-ft.-diameter pulley. The tight side pull is 200 lb. Two driven pulleys are also fastened on the shaft, each of which is 8 in. diameter. The tight side pull on one of the driven pulleys is 110 lb. What is the tight side pull from the other driven pulley?

**Hoisting Devices.**—Pulleys are used to change the direction of a force or to lift heavy loads. When used for the latter purpose, the pulley is generally known as the *block and tackle*. In this elementary discussion, it shall be assumed that the axles are frictionless and that the tension in the continuous rope is constant.

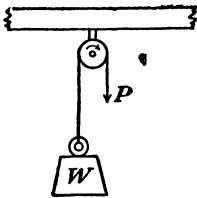

FIG. 81.

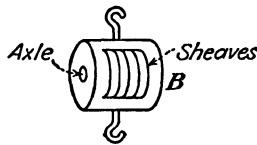

FIG. 82.

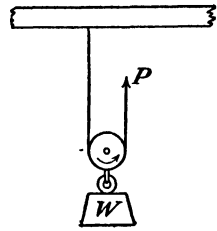

FIG. 83.

The simplest case, and one that gives no mechanical advantage, is shown in Fig. 81. The block *B*, as is shown in Fig. 82, consists of the sheaves (grooved wheels), which are of the same diameter and which can turn independently on a common axle in the block. In Fig. 81 a similar block is fixed to a support, and the pull *P* will lift a

weight  $W$  equal to the pull, the block being used merely to change the direction of the pull.

The other arrangement of this simple case is shown in Fig. 83 in which the block is movable. By the free body principle we are permitted to isolate a part of a machine or structure knowing that the forces which act on that part of the machine must be balanced. Referring to Fig. 84, we see the same arrangement as is shown in Fig. 83 with the movable block isolated and the equal (constant) pulls in the continuous rope shown. Balancing these forces, the sum of the upward forces must equal the downward force ( $V = 0$ ), or

$$2P - W = 0$$

from which

$$2P = W$$

$$P = \frac{W}{2}$$

The mechanical advantage of the block and tackle as shown is always 2.

*Example.*—What pull is required to lift a weight of 120 lb. by means of a block and tackle as shown in Fig. 83, and what is the mechanical advantage of the device?

As the weight is supported by two ropes (Fig. 84), then



FIG. 86.

and

$$2P - W = 0 \quad \text{or} \quad 2P = 120$$

$$P = \frac{120}{2} = 60 \text{ lb.}$$

The mechanical advantage is

$$\frac{W}{P} = \frac{120}{60} = 2$$

The more usual form of block and tackle is shown in Fig. 85, and for convenience in tracing the rope a simple line sketch is shown. Again using the principle of isolating the movable block, as is shown in Fig. 86, and balancing the forces, the upward pulls must equal the downward weight or

$$4P - W = 0 \quad \text{or} \quad 4P = W$$

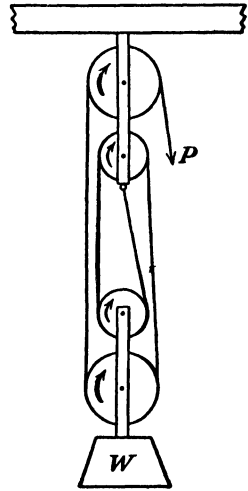

FIG. 85.



FIG. 84.

and

$$P = \frac{W}{4}$$

The mechanical advantage of this block and tackle is the ratio of the resisting force  $W$  to the available force  $P$ . As

$$P = \frac{W}{4}$$

then the mechanical advantage =  $\frac{W}{\frac{W}{4}} = 4$ .

If the rope is threaded by fastening it to the movable block and then continuing over the sheaves, we notice that there are five supporting ropes and

$$5P - W = 0 \quad \text{or} \quad 5P = W$$

and

$$P = \frac{W}{5}$$

as is shown in Figs. 87 and 88.

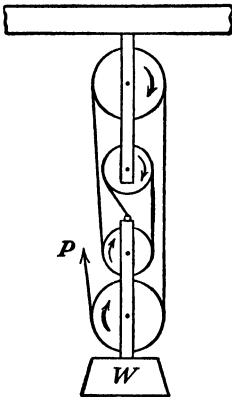

FIG. 87.

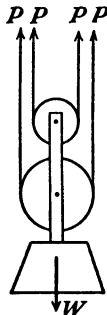

FIG. 88.

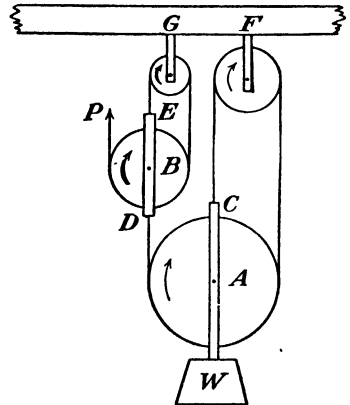

FIG. 89.

The block-and-tackle system shown in Fig. 89 will serve to illustrate the method of determining the correct pull necessary to lift a load  $W$  by using a combination of sheaves and ropes. There is one continuous rope from  $C$  to  $D$  and another continuous rope from  $E$  to  $P$ . Let  $X$  represent the pull in the rope  $CD$  and isolating the movable

pulley block  $A$ , the upward forces must equal the downward force,

$$3X - W = 0 \quad \text{or} \quad 3X = W$$

and

$$X = \frac{W}{3}$$

To determine the reaction  $F$  at the support, a  $V$  equation of equilibrium will indicate that

$$+F - X - X = 0$$

but

$$X = \frac{W}{3}$$

then

$$F = \frac{2W}{3}$$

Now,  $X$  becomes the weight on the movable block  $B$ , and, isolating this block, the upward forces again equal the downward force and

$$3P - X = 0 \quad \text{or} \quad 3P = X$$

and

$$P = \frac{X}{3}$$

From the first movable block  $A$ ,

$$X = \frac{W}{3}$$

then

$$P = \frac{\frac{W}{3}}{3} = \frac{W}{9}$$

If the weight to be lifted had been 1,000 lb., the pull necessary would be

$$P = \frac{1000}{9} = 111.1 \text{ lb.}$$

To determine the reaction  $G$  at the support, a  $V$  equation gives

$$+G - \frac{X}{3} - \frac{X}{3} = 0$$

but

$$\frac{X}{3} = \frac{W}{9}$$

and

$$G = \frac{2W}{9}$$

**Friction Losses.**—Owing to the friction of the sheaves and the ropes, it is not possible to lift a weight with a block and tackle by applying the pulls as calculated by the preceding methods. The actual pull applied must be increased by an amount depending on the condition of the rope and the friction and number of sheaves. From Kent's "Mechanical Engineering Handbook" the following practical rule is obtained: To calculate the actual pull required to raise a load, the amount of the load should be increased 10 per cent for each sheave over which any part of the rope passes. This rule agrees fairly well with other data on friction losses in a block and tackle and, because of its simplicity, will be used.

In Fig. 85, what actual pull  $P$  is necessary to lift a weight of 300 lb.?

The rope passes over four sheaves; hence the weight will be increased

$$\begin{aligned} 4 \times 10\% &= 40\% \\ 40\% \text{ of } 300 &= 120 \text{ lb} \end{aligned}$$

Total weight to be lifted = 120 + 300 = 420 lb.

$$P = \frac{W}{4} = \frac{420}{4} = 105 \text{ lb.}$$

If friction had been neglected,

$$P = \frac{300}{4} = 75 \text{ lb.}$$

The true mechanical advantage of this block and tackle is

$$\frac{\text{Resisting force}}{\text{Available force}} = \frac{300}{105} = 2.86$$

**The Differential Pulley or Chain Hoist.**—An arrangement known as the *differential pulley* or *chain hoist* is often used to lift large weights. Such a device is shown in Fig. 90a. It consists of two sprocket wheels  $A$  and  $B$  of different diameters fastened to the same shaft and a movable block  $C$ . A chain is used, which passes around wheel  $A$ , then around the movable wheel  $C$ , and back around the other sprocket wheel  $B$ . The sprockets, or teeth, on the wheels  $A$  and  $B$  are to prevent the chain from slipping.

This form of block and tackle possesses several advantages. The ratio of the pull to the weight is small, and one man is capable of

lifting a much larger weight by means of the chain hoist than could be lifted by the block and tackles already discussed. In addition, the friction is so great that the mechanism may be stopped at any point, and the pull released, and the weight will stay in that position.

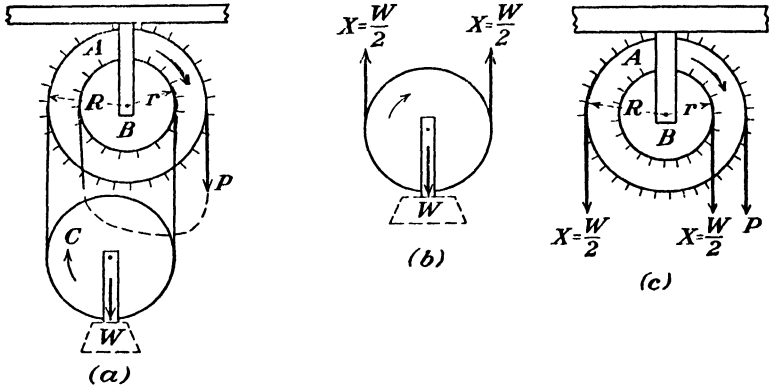

FIG. 90.

Figure 90*b* shows the movable sheave of the hoist, which, as in the ordinary block and tackle, can be isolated to determine the force in the two parts of the chain. Balancing the upward force with the downward force,

$$2X - W = 0 \quad \text{or} \quad 2X = W \quad \text{and} \quad X = \frac{W}{2}$$

Figure 90*c* shows the differential part of the hoist, and the two forces  $X$  as determined, and the pull  $P$ . Since the operation is based on the principle of moments about the center of the axle, the clockwise moments must equal the counterclockwise moments. Hence

$$P \times + R \frac{W}{2} \times r = \frac{W}{2} \times R$$

from which

$$PR = \frac{W}{2} (R - r)$$

and

$$P = \frac{W(R - r)}{2R}$$

The mechanical advantage of the hoist is the ratio  $\frac{W}{P}$ .

The differential pulley operates on the principle that as a pull is applied to the chain at  $P$ , causing the sprocket wheels to turn clockwise, the left chain from the movable pulley is taken up faster than

the right chain to the movable pulley is unbound. This results in an upward motion of the movable block.

Owing to the large amount of friction present in the differential pulley, the hoist can lift only about 30 per cent of the amount as calculated by the above equation. Therefore, to determine the pull necessary to raise a weight  $W$ , the weight should be multiplied by  $3\frac{1}{3}$ .

*Example.*—What pull must be applied to a differential hoist to lift a weight of 200 lb., if the radius  $R = 8$  in. and the radius  $r = 6$  in.?

Total weight to be lifted =  $200 \times 3\frac{1}{3} = 666.7$  lb.

$$P = \frac{W(R - r)}{2R} = \frac{666.7(8 - 6)}{2 \times 8}$$

$$P = \frac{666.7(2)}{2 \times 8} = 83.3 \text{ lb.}$$

### Problems

53. In Fig. 83, a weight of 126 lb. is to be lifted. What pull is required?

54. A block and tackle consists of a fixed block and a movable block, each with three sheaves. If the man pulls up on the movable block, can he raise a weight of 300 lb. if he can exert a pull of 60 lb.? (Friction is to be included.)

55. A differential hoist is to be used to raise a casting weighing 300 lb. The sprocket wheels have radii of  $R = 10$  in. and  $r = 6$  in. What pull must be applied to the chain?

56. Two men can each pull with a force of 84 lb. on a block and tackle shown in Fig. 85. What weight of wheel casting can they lift? What is the mechanical advantage of the device?

57. In Fig. 89, a weight of 200 lb. is to be raised. What pull must a man exert on the rope?

58. A garage uses a single cable to fasten a differential hoist to a ceiling beam. The hoist is used to raise the front end of an automobile, the load being 2,000 lb. The two sprockets of the hoist have radii of 6 in. and 3 in. What pull must be applied to the chain to lift the front end of the car? What pull is placed in the cable after the hoisting has been completed?

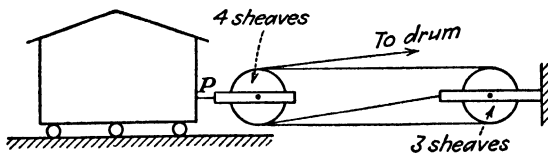

FIG. 91.

59. A house-moving company uses a windlass and a block and tackle in the moving operation shown in Fig. 91. The windlass consists of a 5-ft. lever and a 10-in. diameter drum as shown in Fig. 80. The rope from the drum is threaded through the blocks in a way that is similar to the one used in the block shown in Fig. 82. If the force  $P$  necessary to move the house is 8,000 lb., considering friction in the block and tackle, what force must be applied at the end of the windlass lever?

## CHAPTER IV

### EQUILIBRIUM OF NONCONCURRENT FORCES IN ONE PLANE

It has been shown that when a system of forces in one plane is in equilibrium, the resultant of such a system equals zero and the three equations

$H$ ,  $V$ , and  $M$  separately equal zero, or

$$H = 0 \quad V = 0 \quad M = 0$$

By making use of the free body principle and of one or more of the above equations of equilibrium, it is possible to calculate the

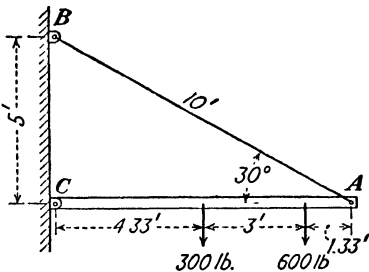

FIG. 92.

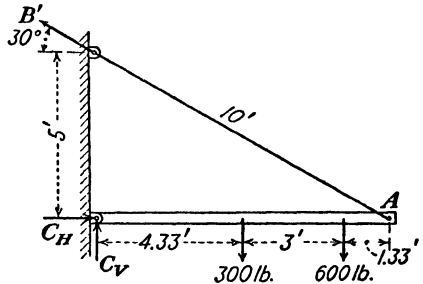

FIG. 93.

unknown forces which are exerted upon a structure as a whole, or which are applied to a part of a structure. The term *structure* is meant to include any machine, part of a machine, or body that is designed and used to transmit force.

Let us consider a wall bracket as shown in Fig. 92. This differs from the bracket crane shown in Fig. 32 principally in the positions of the applied forces and the method of solution is slightly different. Let it be required to determine the amount of the wall reaction at  $C$  and the pull in the tie rod  $AB$ , neglecting the weights of the members. Figure 92 is redrawn as Fig. 93 to include the reactions (forces) of the wall on the structure.

For any member of a frame it is necessary to know the direction of the deformation that takes place owing to the applied forces. If a member is so loaded that the deformation is parallel to its main axis,

then the forces (reactions) that are applied (at the ends) must be collinear or parallel to the member as shown in Fig. 94.

When the applied forces tend to cause the member to be deformed in a direction other than that which is parallel to its main axis, the forces (reactions) which occur at the ends will *not* be collinear. This is shown in Fig. 95.

Since the reaction at  $C$  (Fig. 93) is unknown in amount and direction, we will resolve it into its components, calling the horizontal component  $C_H$  and the vertical component  $C_V$ . The reaction at  $B$  is called  $B'$  and must act in the same direction as the tie rod  $AB$ , since the tie rod will be a tension member, that is, it will be stretched owing to the

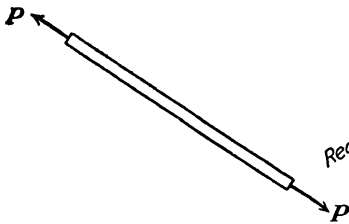

FIG. 94.

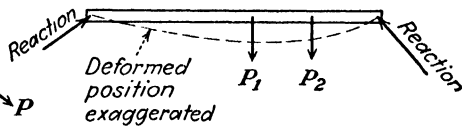

FIG. 95.

action of the forces applied to the wall bracket. It should be noted that there are *three* unknown reactions to be solved, namely,  $C_H$ ,  $C_V$ , and  $B'$ .

The solution of the three unknown reactions may be simplified by the proper choice of centers about which moment equations of equilibrium ( $M = 0$ ) may be written. Thus, selecting the intersection of two unknown forces as the center of moments, the lever arms of these two forces are zero; hence their moments are zero. With point  $B$  as the center of moments, since  $C_V$  and  $B'$  intersect at  $B$ , the moment equation is

$$M_B = -C_H \times 5 + 300 \times 4.33 + 600 \times 7.33 = 0$$

from which

$$\begin{aligned} 5C_H &= 300 \times 4.33 + 600 \times 7.33 \\ &= 1,300 + 4,400 = 5,700 \\ C_H &= 1,140 \text{ lb.} \end{aligned}$$

With  $A$  as the center of moments (the point of intersection of  $B'$  and  $C_H$ ), the moment equation is

$$M_A = +C_V \times 8.66 - 300 \times 4.33 - 600 \times 1.33 = 0$$

and

$$\begin{aligned} 8.66C_V &= 1,300 + 800 \\ &= 2,100 \\ C_V &= 242 \text{ lb.} \end{aligned}$$

With  $C$  as the center of moments (the point of intersection of  $C_H$  and  $C_V$ ), the moment equation is

$$M_C = -B' 5 \cos 30^\circ + 300 \times 4.33 + 600 \times 7.33 = 0$$

and

$$\begin{aligned} 5B' \cos 30^\circ &= 1,300 + 4,400 \\ 4.33B' &= 5,700 \\ B' &= 1,314 \text{ lb.} \end{aligned}$$

It should be noted that the three unknown reactions have been solved without using any of the values that had been calculated previously. This is desirable, as it permits the use of the  $H$  and  $V$  equations for checking purposes.

Setting up the  $H$  and  $V$  equations,

$$\begin{aligned} H &= +C_H - B' \cos 30^\circ = 0 \\ V &= +C_V + B' \sin 30^\circ - 300 - 600 = 0 \end{aligned}$$

Using the  $H$  equation and substituting the values of  $C_H$  and  $B'$ ,

$$\begin{aligned} +C_H - B' \cos 30^\circ &= 0 \\ +1,140 - 1,314 \times \cos 30^\circ &= 0 \\ 1,140 - 1,140 &= 0 \end{aligned}$$

The  $V$  equation will also check; thus

$$\begin{aligned} V &= +C_V + B' \sin 30^\circ - 300 - 600 = 0 \\ +242 + 1,314 \times \sin 30^\circ - 300 - 600 &= 0 \\ +242 + 657 - 300 - 600 &= 0 \\ 899 - 900 = 0 &\quad \text{which is practically an exact check.} \end{aligned}$$

Then, to complete the solution of the total reaction at  $C$ , as  $C_H = 1,140$  lb. and  $C_V = 242$  lb.,  $C$  is their resultant.

$$\begin{aligned} C &= \sqrt{1,140^2 + 242^2} = 1,160 \text{ lb.} \\ \tan D &= \frac{C_V}{C_H} = \frac{242}{1,140} = 0.2123 \\ \text{angle } D &= 11^\circ 47' \text{ (see Fig. 96)} \end{aligned}$$

In some cases, it is not necessary to resolve a reaction into its horizontal and vertical components, but the solution will be easier by this method if a reaction is unknown in amount and direction.

In Fig. 97, solve the reactions  $A$ ,  $B_V$ , and  $B_H$ . Resolve the 2-ton force into its horizontal and vertical components, 1.732 tons and 1 ton, respectively, and then write the  $H$  and  $V$  equations.

$$H = -1.732 + B_H = 0$$

from which

$$B_H = 1.732 \text{ tons}$$

$$V = -5 - 1 + A - B_V = 0$$

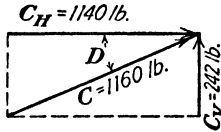

FIG. 96.

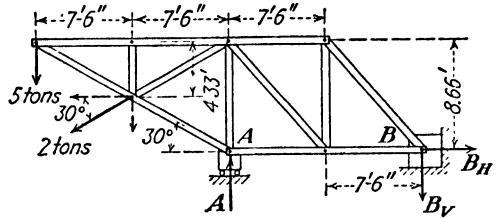

FIG. 97.

Selecting  $B$  as the center of moments (the intersection of  $B_H$  and  $B_V$ ), the moment equation is

$$\begin{aligned} M_B &= +A \times 15 - 1.732 \times 4.33 - 1 \times 22.5 - 5 \times 30 = 0 \\ 15A &= 7.5 + 22.5 + 150 \\ &= 180 \\ A &= 12 \text{ tons} \end{aligned}$$

Selecting  $A$  as the center of moments (the intersection of  $B_H$  and  $A$ ), the moment equation is

$$\begin{aligned} M_A &= +B_V \times 15 - 1 \times 7.5 - 1.732 \times 4.33 - 5 \times 15 = 0 \\ 15B_V &= 7.5 + 7.5 + 75 \\ &= 90 \\ B_V &= 6 \text{ tons} \end{aligned}$$

As  $B_H$  has been solved by the  $H$  equation, the problem has been completed, except for checking the results by the  $V$  equation.

$$\begin{aligned} V &= -5 - 1 + A - B_V = 0 \\ -5 - 1 + 12 - 6 &= 0 \\ -12 + 12 &= 0 \quad \text{which is correct.} \end{aligned}$$

A simple hoist is shown in Fig. 98. When a load of 2,000 lb. is hung from the ring at  $A$ , what are the amounts and directions of the

reactions? As the post  $BD$  is set in a socket in the ground, the ground will provide an upward vertical reaction and a horizontal reaction. Support  $C$  also provides a horizontal reaction. Assuming that the direction of the horizontal reaction at  $D$  acts to the right, and the one at  $C$  to the left, let the three reactions be designated as shown.

Writing the  $H$  and  $V$  equations of equilibrium, and since the  $V$  equation contains only one unknown, solving for it, we have

$$H = +D_H - C_H = 0$$

or

$$D_H = C_H$$

and

$$V = +D_V - 2,000 = 0$$

$$D_V = 2,000 \text{ lb.}$$

As  $D_H$  and  $D_V$  intersect at  $D$ , the moment equation with  $D$  as the center of moments is

$$M_D = -C_H \times 2 + 2,000 \times 4 = 0$$

and

$$2C_H = 8,000$$

$$C_H = 4,000 \text{ lb.}$$

$D_V$  and  $C_H$  intersect at  $C$ ; hence the moment equation with  $C$  as the center of moments is

$$M_C = -D_H \times 2 + 2,000 \times 4 = 0$$

and

$$2D_H = 8,000$$

$$D_H = 4,000 \text{ lb.}$$

From the  $H$  equation,  $D_H$  equals  $C_H$ , which is checked by the results, or  $D_H = C_H = 4,000$  lb.

It will be seen that no exact procedure can be applied to all structures but the following general statements will be found useful:

1. Write the complete  $H$  and  $V$  equations of equilibrium. Solve either equation if that equation contains only one unknown force.
2. Write moment equations with the intersection of two unknown reactions as centers, eliminating them from the equation. Solve for the third unknown reaction in each case.

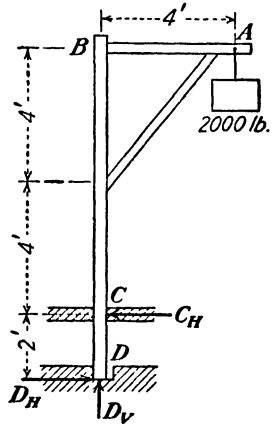

FIG. 98.

Problems

60. Solve the reaction  $A'$  and the components of the  $B'$  reaction of the bracket shown in Fig. 99.

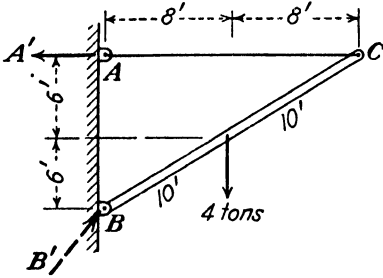

FIG. 99.

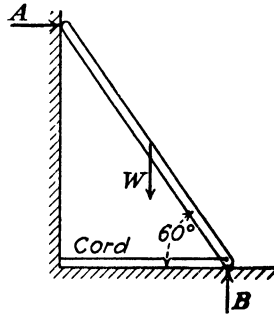

FIG. 100.

61. A ladder, which is 20 ft. long, has its weight (30 lb.) concentrated at the center of its length. The ladder rests on a smooth floor and leans against a smooth wall. The lower end is prevented from slipping by means of a horizontal cord tied to the wall, as shown in Fig. 100. Calculate the amounts of the  $A$  and  $B$  reactions and the tension in the cord.

62. Solve the reaction  $A'$  and the components of the reaction  $B'$ . What is the amount and direction of the reaction  $B'$  (see Fig. 101)?

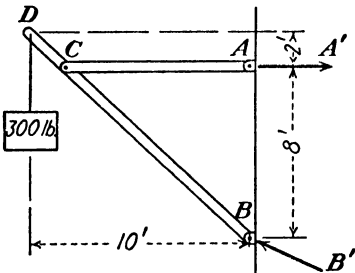

FIG. 101.

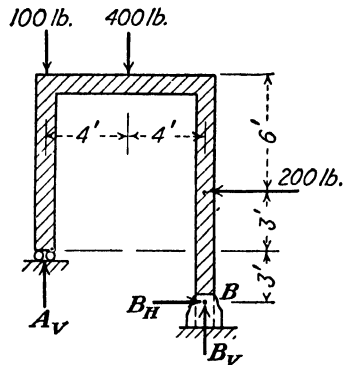

FIG. 102.

63. The frame shown in Fig. 102 is used to support the three forces. The reaction at  $A$  is vertical due to the roller system resting on a horizontal plane. What is the amount of each of the three reactions  $A_V$ ,  $B_H$ , and  $B_V$  (see Fig. 102)?

64. A safe door weighs 3 tons. Considering this weight to act at the center of the door, what is the amount of each of the hinge reactions (see Fig. 103)?

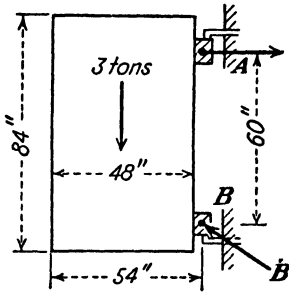

FIG. 103.

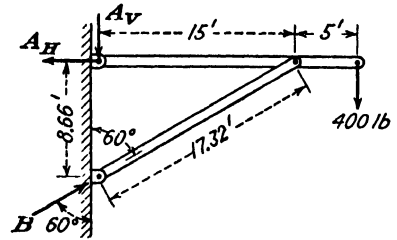

FIG. 104.

65. Solve the components ( $A_v$  and  $A_h$ ) of the  $A$  reaction and the  $B$  reaction (Fig. 104).

66. Solve the reactions  $A$ ,  $B_h$ , and  $B_v$  in Fig. 105.

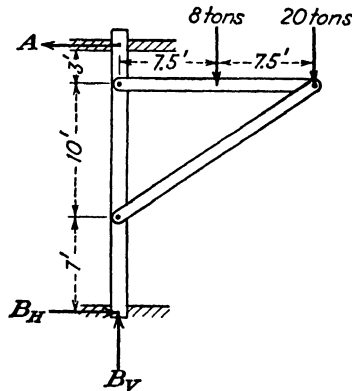

FIG. 105.

67. Solve the reactions  $A_h$ ,  $A_v$ , and  $B_v$  in Fig. 106.

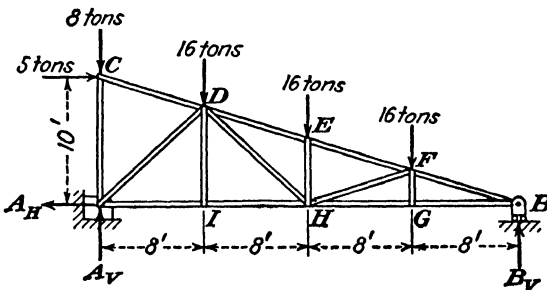

FIG. 106.

## BRIDGE AND ROOF TRUSSES

Bridge and roof trusses, some sketches of which are shown in Figs. 107 and 108, are additional examples of equilibrium of forces in one plane. Such structures are supported at two points called the *abutments*, or *piers*, and are loaded so that the loads are applied to the joints or panel points (the intersections of the members) of the truss.

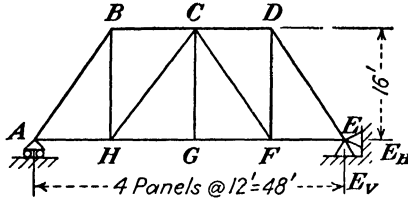

FIG. 107.

The loads that the truss supports are composed of the weight of the truss itself together with the weight of the floor of the bridge or roof material, and the weight of the cars, trucks, etc., or the snow and wind.

One end of the truss is set upon the support and fastened to it. The other end is fastened to its support in such a manner that expansion or contraction due to changes in temperature can take place. In the shorter spans, the anchor boltholes in the truss are slotted, allowing this end of the truss to slide on steel plates set on the support.

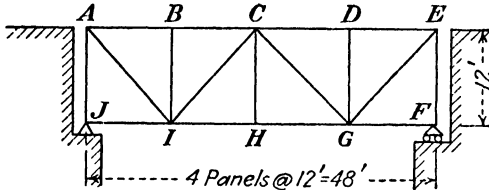

FIG. 108.

The diagrammatic sketch, Fig. 107, of the expansion end *A* of a truss shows rollers; the direction of the reaction at this point is perpendicular to the surface on which the rollers would move. As the fixed end of the truss is anchored to the support, this support will provide both horizontal and vertical reactions, as shown in Fig. 107. The parts *AH*, *HG*, *GF*, and *FE* are termed panels, generally equal. The members *AB*, *BC*, *CD*, and *DE* form the upper chord of the truss, while *AH*, *HG*, *GF*, and *FE* form the lower chord of the truss. The interior members, such as *BH*, *CH*, *CG*, *CF*, and *DF*, are called *web members*.

A through bridge truss is one in which the roadway is carried by the lower chord panel points. Figure 107 is an example of a through truss. When the roadway is carried by the upper chord panel points, the truss is called a *deck truss*. Figure 108 shows a sketch of a deck truss where *A, B, C, D,* and *E* are the upper chord panel points and *J, I, H, G,* and *F* are the lower chord panel points.

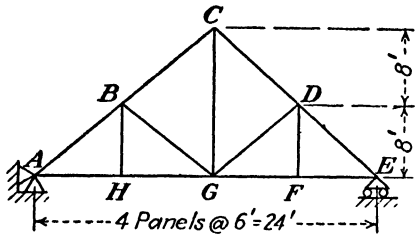

FIG. 109.

Figure 109 shows a typical roof truss, with the upper chord system being *A, B, C, D,* and *E,* and the lower chord system being *A, H, G, F,* and *E.* This truss has the right end on a roller system, the left end being fixed to the support.

Before a truss or any of its members can be designed correctly, it is necessary to determine the amount and kind of stress acting in each of the members that make up the truss. Before the stress in each member can be determined, it is necessary to know the amount and

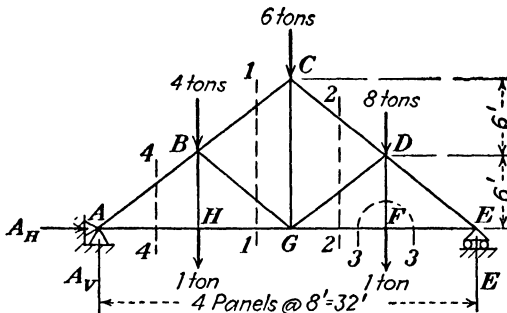

FIG. 110.

location of the loads that the truss will support. In all trusses, the weight of the truss must be considered. For highway trusses, the loads due to traffic must be assumed; for railroad trusses, the loads due to trains must be assumed; for roof trusses, snow and wind loads must be assumed. These assumptions are based upon the maximum loads expected, and standard loadings have been formulated by engineers. However, to simplify the problems considered here, the loads will be assigned arbitrarily. This will not change the methods used to calculate stresses.

Considering the roof truss shown in Fig. 110 to be loaded as

indicated, let it be required to calculate the stresses in members  $HG$ ,  $CD$ ,  $DF$ , and  $AH$ .

*Solution.*

1. Calculate the reactions at  $A$  and  $E$ .

Writing a moment equation about  $A$ ,

$$M_A = 1 \times 8 + 4 \times 8 + 6 \times 16 + 1 \times 24 + 8 \times 24 - E \times 32 = 0$$

$$E = \frac{8 + 32 + 96 + 24 + 192}{32} = 11 \text{ tons}$$

Writing a moment equation about  $E$ ,

$$M_E = -1 \times 8 - 8 \times 8 - 6 \times 16 - 1 \times 24 - 4 \times 24 + A_v \times 32 = 0$$

$$A_v = \frac{8 + 64 + 96 + 24 + 96}{32} = 9 \text{ tons}$$

By an  $H$  equation

$$A_H = 0$$

2. In order to determine the stress in any member of a truss, it is necessary to consider that the *truss* is cut by an imaginary line which cuts the member whose stress is desired and not more than two other members. Generally the imaginary cut is straight, but a circular cut (around a panel point) may be used sometimes to advantage.

The portion of the truss to the right *or* to the left of the cut can be considered as a free body in equilibrium under the action of all the applied forces on the portion used, including reactions *and* the stresses (unknown) in the members cut.

To solve the stress in member  $HG$

Cut the truss on line 1-1 as shown in Fig. 110, and draw the portion of the truss to the left of the cut (Fig. 111). Note that line 1-1 cuts members  $BC$  and  $BG$  as well as  $HG$ . Assume a tensile direction on *each* member that is cut off by placing an arrow directed toward the *free* end of each member cut. Then, if the resulting answer is positive, the stress is tension as assumed, while a negative answer indicates a wrong assumption and the stress is compression. As the stresses (forces) in members  $BC$  and  $BG$  intersect at  $B$ , a moment equation with  $B$  as the center of moments will eliminate  $BC$  and  $BG$  from the equation, and  $HG$  can be solved.

$$M_B = 4 \times 0 + BC \times 0 + BG \times 0 + 1 \times 0 - HG \times 6 - A_H \times 6 + 9 \times 8 = 0$$

$$6HG = 9 \times 8$$

and

$$HG = \frac{72}{6} = +12 \text{ tons (tension)}$$

Cutting the truss on line 2-2, and using the portion to the right (Fig. 112), it will be noted that in the free body diagram members

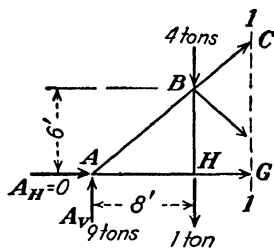

FIG. 111.

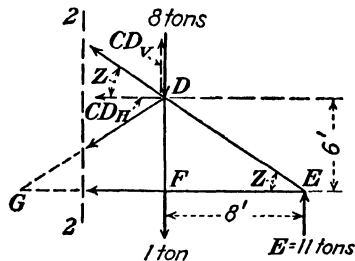

FIG. 112.

(forces)  $GD$  and  $GF$  when extended will intersect at  $G$ . Therefore, to solve the stress in member  $CD$ , write a moment equation with  $G$  as the center.

Resolving  $CD$  into its horizontal and vertical components,

$$CD_v = CD \sin Z = CD \times \frac{6}{10} = 0.6CD$$

$$CD_H = CD \cos Z = CD \times \frac{8}{10} = 0.8CD$$

$$M_G = -CD_H \times 6 - CD_v \times 8 + 8 \times 8 + 1 \times 8 - 11 \times 16 = 0$$

$$-0.8CD \times 6 - 0.6CD \times 8 + 64 + 8 - 176 = 0$$

$$-4.8CD - 4.8CD + 72 - 176 = 0$$

$$-9.6CD = +104$$

$$CD = -\frac{104}{9.6} = -10.83 \text{ tons (compression)}$$

To solve the stress in member  $DF$ , cut the truss, as shown, in a circular direction around panel point  $F$  (line 3-3), considering panel

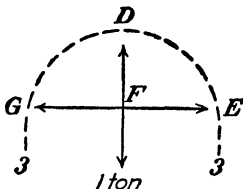

FIG. 113.

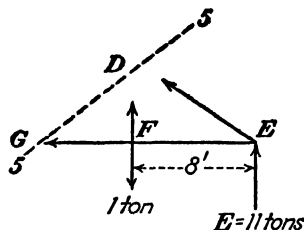

FIG. 114.

point  $F$  as a free body. This is shown in Fig. 113. Assuming that there are (tensile) arrows toward the free ends of each member cut,

it will be seen that all the four forces are concurrent. Hence, writing a  $V$  equation,

$$V = +DF - 1 = 0$$

then

$$DF = +1 \text{ ton (tension)}$$

An alternate solution for member  $DF$  may be used by cutting the truss on line 5-5, as shown in Fig. 114. Since  $DE$  and  $GF$  intersect at  $E$ , a moment equation may be written with  $E$  as the center of moments

$$M_E = DE \times 0 + DF \times 8 + GF \times 0 - 1 \times 8 + 11 \times 0 = 0$$

then

$$8DF = 1 \times 8$$

$$DF = +1 \text{ ton (tension)}$$

When solving for the stress in member  $AH$ , a cut should be made on line 4-4. Using the part of the truss to the left of line 4-4 as a free

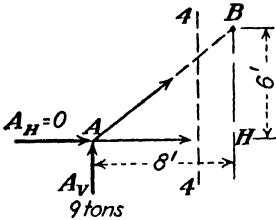

FIG. 115.

body, Fig. 115, it will be noticed that the forces are concurrent at point  $A$ ; but to solve the stress in  $AH$  by means of the  $\Sigma M$  and  $\Sigma V$  equations requires that the stress in  $AB$  be solved first.

In keeping with the idea of solving the stress in any member without knowing the stress in any other member, it should be remembered that the moment of a force

about any point on the line of action of the same force is zero. Hence, by selecting a convenient point on the line of action of  $AB$  (other than point  $A$ ), the moment of  $AB$  will be zero. Then, by using point  $B$  as the center of moments,

$$M_B = +9 \times 8 - AH \times 6 + AB \times 0 = 0$$

$$6AH = 9 \times 8$$

$$AH = \frac{72}{6} = +12 \text{ tons (tension)}$$

To summarize the procedure for solving the stress in any member of any truss:

1. Solve the reactions.
2. Cut the truss by an imaginary line, cutting the member whose stress is desired and not more than two other members.

3. Consider the portion of the truss to the right *or* left of the imaginary cut as a free body.

4. Place arrows on the members cut, with the arrows directed toward the free ends of these members.

5. *Do not consider* the stresses in any *members* that are not cut.

6. Select an equation of equilibrium,  $\Sigma H = 0$  or  $\Sigma V = 0$  or  $\Sigma M = 0$ , that will not contain the members cut whose stresses are *not* desired. This eliminates these members from the equation being used, and permits the solution of the stress in the desired member as an independent unknown.

7. Write the complete equation selected in accordance with paragraph (6), being careful to use all the forces and reactions (or reaction) on the part of the truss being used as a free body.

8. Solve the equation. Follow the algebraic signs carefully. If the resulting sign is positive, the stress in the member is tension (as assumed). If the resulting sign is negative, the stress in the member is compression.

**Problems**

68. In Fig. 116, solve the stresses in members *BC*, *CE*, and *FE*.

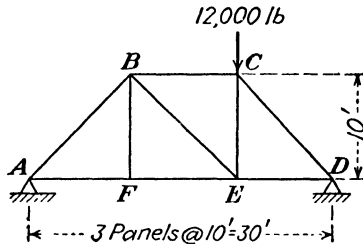

FIG. 116.

69. In Fig. 117, the truss is to be designed to support the three loads attached to the lower chord. Solve the stresses in members *BJ*, *CD*, *EG*, *DG*, and *GF*.

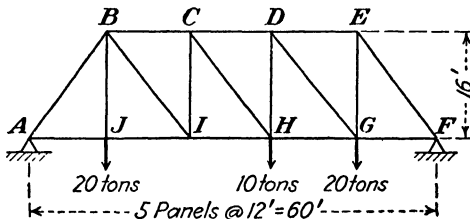

FIG. 117.

70. In Fig. 118, solve the stresses in members *GF*, *BC*, *DF*, and *DE*.

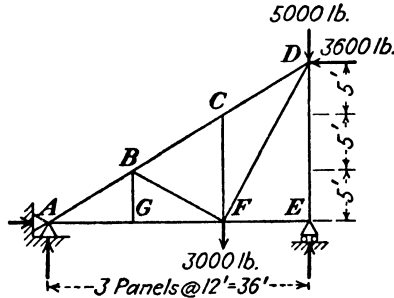

FIG. 118.

71. Figure 119 shows a partly loaded swing bridge truss. What are the stresses in members *BC*, *HD*, *CI*, *DG*, and *HI*?

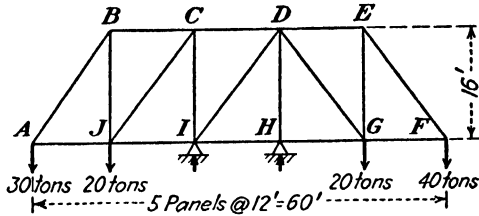

FIG. 119.

72. Figure 120 shows a truss with the upper chord curved. Find the stresses in members *IJ*, *CI*, *DG*, and *BJ*. In order to solve the stress in member *BJ*, the method will involve a moment equation about the intersection of two of the unknown cut members (forces) to the left of the truss.

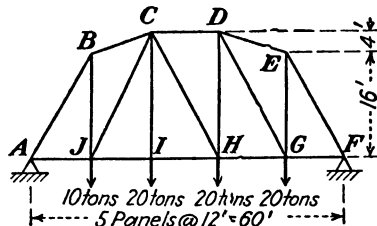

FIG. 120.

73. Solve the stresses in members *EF*, *CD*, and *AD* of the truss shown in Fig. 106 and problem 67.

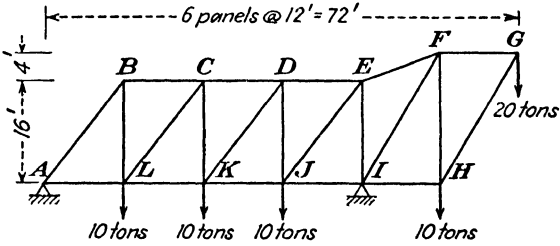

FIG. 121.

74. Solve the stresses in members  $BC$ ,  $KJ$ ,  $EF$ , and  $FG$  of the truss shown in Fig. 121.

## CHAPTER V

### SCREWS AND THREADS

A screw is a cylinder having a uniform inclined groove wound or cut around its surface at equidistant spaces.

In all respects the nut is similar to the screw except that in the nut the threads are cut around the inside of the cylindrical hole instead of around the outside.

**Forms of Threads.**—Screws are made in many forms, depending upon the use for which they are intended. The groove in which the nut works may be rectangular, triangular, or any one of a great many possible forms, without modifying the relative motion transmitted.

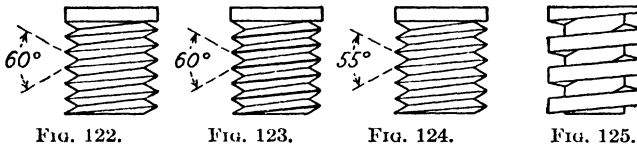

Figure 122 is a view of the most common form of thread, known as the V thread. The angle between the sides is  $60^\circ$ , so that a section of the thread will be an equilateral triangle.

Figure 123 is another common form of thread known as the *Sellers* or the *U. S. Standard thread*. This is different from the V thread only in that one-eighth of the V is cut off from the top and bottom of the thread.

Figure 124 is the English standard known as the *Whitworth thread*. Here the angle between the sides is but  $55^\circ$ , and one-sixth of the V cut is rounded off at both the top and bottom of the thread.

The common form of square-threaded screw is shown in Figure 125. It has such a large contact surface that it is generally used to transmit energy, as in the jackscrew. For the lead screw on lathes, shapers, and similar machines, this thread is modified so that the sides have a slight taper.

There are many other kinds of threads in use but practically all of them are modified forms of those shown here.

The *pitch* of all screw threads is the axial distance between corresponding points on adjacent threads. Screws are commonly desig-

nated by the number of threads per inch, that is, a screw of 8-in. pitch is called a *screw of 8 threads per inch*.

**Multiple-threaded Screws.**—If the pitch of a thread be large enough to permit it, a second or third thread may be cut on the cylinder. When two or more threads are thus cut on the same cylinder, all threads being kept at equidistant spaces, a multiple-threaded screw will result. By the use of a multiple-threaded screw, the distance of travel per revolution is greatly increased (see Figs. 126a to c).

**Lead.**—The lead is the axial advance made by a thread in one complete turn around the base cylinder. In the single-thread screws, the pitch and lead are identical, but in the multiple-thread screws they are different. Thus for a triple-thread screw, the lead is three times the pitch (see Figs. 105a to c).

**Standard Representation of Threads.**—It is obvious that if drawings such as those shown in Figs. 122, 123, 124, and 125 had to be made in order to represent the various threads that occur in a machine, the operation would be long and difficult. On that account threads are shown as in Figs. 127 and 128, and the nature of the thread is designated by means of a note that accompanies the drawing.

**Right- and Left-handed Threads.**—Most beginners have difficulty in distinguishing between a right- and a left-handed thread. A positive distinction between them is that a right-handed thread has to be turned to the right in order to advance, while the opposite holds true for the left-handed one.

**The Jackscrew.**—Although in most machines screws are more frequently used as fastening devices than as a means of transmitting motion, the latter use is important in some forms of apparatus.

In the jackscrew, Fig. 129, the screw *M* is turned in the nut *N* by means of a force that is exerted on the handle *K*. For one complete revolution of the handle the screw will move up from the nut

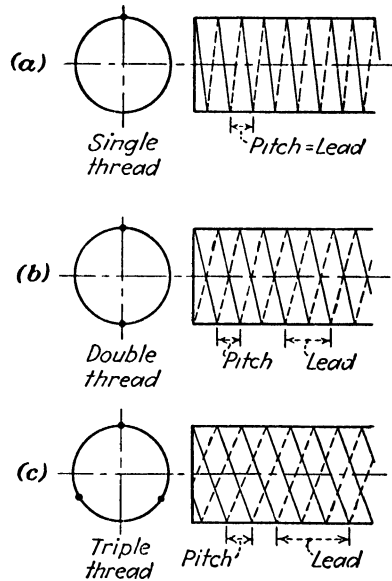

FIG. 126.

a distance equal to the pitch. Now if  $R$  is the length of the handle and  $P$  is the force applied at its end, then in order to raise the screw a distance equal to its pitch, the force  $P$  will have to move through a distance equal to the circumference of the circle with  $R$  as a radius. It will be evident, then, since work\* equals force times distance, that the work done in raising the jack a distance equal to the pitch will be the force  $P$  times the distance  $2\pi R$ .

$$\text{Work put in per revolution} = 2\pi RP$$

Now if  $p$  represents the pitch of the threads on  $M$  and  $N$ , and if  $W$  represents the weight that is being raised, then when the handle has

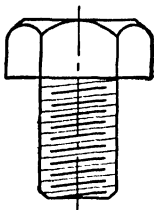

FIG. 127.

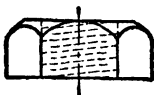

FIG. 128.

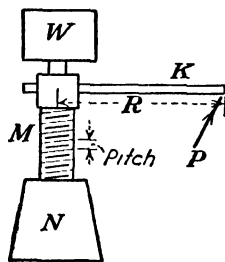

FIG. 129.

made 1 revolution, the weight  $W$  has been raised a distance equal to  $p$ , so that the work done will be the force  $W$  times the distance  $p$ .

$$\text{Work taken out per revolution} = Wp$$

Assuming that there is no friction in the jackscrew, then the work put in equals the work taken out or

$$2\pi RP = Wp$$

This gives a definite relation between the weight, the pitch, and the force applied, so that if any two of them are known or assumed the other may be determined.

A force is anything that tends to change the state of a body with respect to its rest or motion. Friction therefore is a force, since it tends to bring to rest everything that is in motion. Now, since in all machines this force of friction is acting to a greater or less extent to oppose the force that tends to keep the machine in motion, it is necessary to put into the machine an extra amount of work or power to compensate for that lost in friction. This work that is lost in over-

\* The term *work* is fully explained in the chapter on work, energy, and power.

coming friction appears again in the form of heat. An overheated bearing is a frequent example of friction resisting motion and thus causing heat.

**Efficiency.**—The total amount of work put into a machine is called the *input*. The total amount of work that comes out of a machine is called the *output*. The output will be less than the input by the amount equal to that used up in overcoming friction. The ratio of output to input is called *efficiency*.

$$\text{Efficiency} = \frac{\text{output}}{\text{input}}$$

Therefore, efficiency will always be expressed as a percentage, and, since the output must always be less than the input, this percentage will always be less than 100 per cent. If the output of a machine could be made greater than the input, we would in effect be getting energy from nothing, which we recognize as an impossibility.

If the input of a machine is 150 ft.-lb., and if 35 ft.-lb. is lost in friction, the output will be

$$150 - 35 = 115 \text{ ft.-lb.}$$

and the efficiency will be

$$\frac{115}{150} = 0.767 \quad \text{or} \quad 76.7\%$$

Let this action of friction be considered in connection with the jackscrew, as explained in this chapter. It was shown that, no friction being assumed, the work put in equaled the work taken out, or

$$2\pi RP = Wp$$

Now if this jackscrew is but 60 per cent efficient, that is, if 40 per cent of the work put in is lost in friction, the work taken out will be but 60 per cent of that put in, so that the equation will then read

$$0.60(2\pi RP) = Wp$$

Likewise, the effect of friction may be considered in the other simple machines.

**Worm and Worm Wheel.**—A screw meshing with a cogged wheel is shown in Fig. 130. This arrangement is known as *worm* and *worm wheel*. Here each revolution of the screw, or worm, as it is generally

called, will cause the worm wheel to rotate a distance equal to the lead of the worm. It will be apparent from the figure that if the

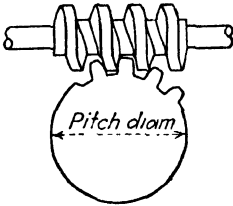

FIG. 130.

worm is turned through one complete revolution, each tooth on the worm wheel will move forward such a distance that it will occupy the position the adjacent tooth had before the turning took place. Therefore, 1 revolution of the worm will move the worm wheel a distance represented by one tooth. To make one complete revolution of the worm wheel it will be

necessary for the worm to make as many revolutions as there are teeth on the worm wheel.

**Problem.**—If the worm in Fig. 130 is making 200 r.p.m., how many revolutions will the wheel make if it has 120 teeth?

**Solution.**—Two hundred revolutions of the worm will move the worm wheel a distance equal to 200 teeth. But since there are 120 teeth on the worm wheel, its r.p.m. will be

$$\frac{200}{120} = 1.67 \text{ r.p.m. Answer}$$

This problem of velocity ratio between worm and wheel may also be solved by using the pitch and the pitch diameter of the wheel instead of using the number of teeth. In this same problem the worm wheel is 12 in. in pitch diameter and has a pitch of 0.314 in. Now every revolution of the worm will cause the worm wheel to move forward a distance equal to the pitch so that 200 revolutions of the worm will cause the worm wheel to move a distance equal to 200 times the pitch, or

$$200 \times 0.314 = 62.8 \text{ in.}$$

Since the circumference of the worm wheel is  $2\pi R$ , or 37.68 in., every time the worm wheel has moved through a distance equal to 37.68 in. it has made 1 revolution. Hence, in going through 62.8 in., the worm wheel has made

$$\frac{62.8}{37.68} = 1.67 \text{ r.p.m. as before}$$

If the worm is double- or triple-threaded, its lead will be correspondingly larger, so that in solving problems by the latter method the process will be identical. However, if the former method is used, it must be remembered that a double- or triple-threaded worm will cause the worm wheel to move a distance equal to two or three teeth for each revolution of the worm.

Another use of the worm is as a *lead screw* in connection with a slide as shown in Fig. 131.

The distance that the slide advances in 1 revolution of the screw is equal to the lead of the worm. On a single-threaded screw, the lead is equal to the pitch; on a double-threaded screw, the lead is twice the pitch; etc. Thus, if the pitch of a lead screw is  $\frac{1}{8}$  in. and it is single-threaded, how far will the slide advance in 4 revolutions of the screw?

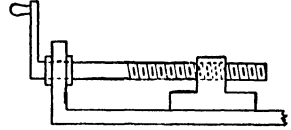

FIG. 131.

As the screw is single-threaded, the lead is equal to the pitch; hence,

$$\text{Lead} = \frac{1}{8} \text{ in.}$$

Then the slide will advance

$$\frac{1}{8} \times 4 = \frac{1}{2} \text{ in.}$$

### Problems

75. (a) Distinguish between the terms *pitch* and *lead* as now generally used.

(b) If the pitch of a double-threaded screw is  $\frac{3}{8}$  in., what is the lead?

(c) If the lead of a triple-threaded screw is  $\frac{7}{8}$  in., what is the pitch?

76. If the lead of a jackscrew is  $\frac{1}{4}$  in., what force must be exerted at the end of a 16-in. bar in order to raise a weight of 2,000 lb.? (It is assumed that there is no friction.)

77. In problem 76, find the required force if the jack is 65% efficient.

78. The lead of a jack is  $\frac{1}{8}$  in. What weight would require a force of 20 lb. exerted on a bar at a point 12 in. from the center of this jack?

79. A worm wheel having 80 teeth is being driven by a single-threaded worm making 220 r.p.m. How many r.p.m. is the wheel making?

80. A worm wheel 8 in. in diameter has a pitch of 0.393 in. How many r.p.m. will this wheel make if it is driven by a single-threaded worm making 165 r.p.m.?

81. A single-threaded lead screw has 6 threads per inch. How many revolutions must the screw make to advance the slide 0.495 in.?

82. Assume that the worm in problem 79 was triple-threaded. How many r.p.m. would the wheel make?

83. If 33% of the work is lost in friction, how many foot-pounds of work must be put in a machine in order that 340 ft.-lb. of work will be delivered?

84. A machine turns out power equal to 18 hp. If it requires 22 hp. to drive the machine, (a) how much power is lost in friction, and (b) what is the efficiency of the machine?

### PULLEYS

Pulleys are generally divided into two classes: the solid pulley in which all parts are in the same casting, and the split pulley which is cast in halves and is then fastened together on the shaft. The use

of the split pulley secures convenience and economy of time in placing them on a shaft or removing them, since it is unnecessary to disturb couplings, hangers, collars, or other pulleys in position. These pulleys are often supplied with interchangeable bushings so that the same pulley may be used on shafts of different diameters.

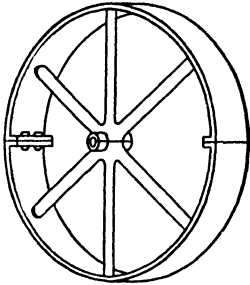

FIG. 132.

Wooden pulleys are used for certain purposes. They are built up of many small pieces of wood securely glued together. They are made in both split and solid form. Belts grip wood better than metal, so that lighter belts and less tension may be used than with metal pulleys. Figure 132 shows a split pulley of the metal type.

**Face.**—The acting surface of a pulley is called the *face*. The face is always made a little wider than the belt that it carries.

**Crown.**—As a rule, belts are not uniform or straight, and pulleys will not always run in the proper position. Therefore, belts would run off the pulleys unless some means were taken to prevent it. This is accomplished by means of raising the rim of the pulley so that its face has a slightly tapered form, as shown in Fig. 133. This taper is known as the *crown* of the pulley. Belts always work toward the position where they are tightest, so that if a pulley is crowned the belt will tend to remain in the middle of the face.

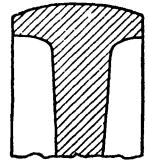

FIG. 133.

**Tight and Loose Pulleys.**—Most machines driven from a line shaft are so arranged that the machine may be stopped without stopping the line shaft. Of the methods for doing this, the one in general use is that known as the *tight and loose pulley*.

This consists of two pulleys, placed side by side on the counter-shaft, as shown at *B* and *C* in Fig. 134. Here *B* is keyed to the shaft and is known as the *tight pulley*, while *C*, which is free to turn on the shaft but which cannot move laterally, is known as the *loose pulley*. In the figure, the belt is now on the *tight pulley*, so that shaft *E* rotates as the lower pulley *A* is rotated and the machine will run. If, however, the belt shifter *D* is moved over so as to cause the belt to come on the *loose pulley C*, the machine will stop, since pulley *C* will merely rotate without causing shaft *E* to rotate.

**Guide Pulleys.**—The condition necessary for a belt to run on a pulley is that the center line of the advancing side of the belt comes to the center of the face of the pulley. Often, therefore, it becomes

necessary to connect pulleys where this condition cannot be fulfilled without the use of additional pulleys. These additional pulleys are known as *guide pulleys*, or, sometimes, simple idlers. Figure 135 shows the use of the guide pulleys to connect shafts that are not parallel.

**Ratio between Diameters and R.p.m.**—Suppose that the pulley *A*, Fig. 136, is driving the pulley *B*. As the belt moves around these pulleys, all points on the belt must have the same speed so that the surfaces of the pulleys will move with the same speed. Assume that the pulley *A* has a diameter equal to *D* and that it is making *N* revolutions per minute. Assume also that *B* has a diameter equal to *d* and

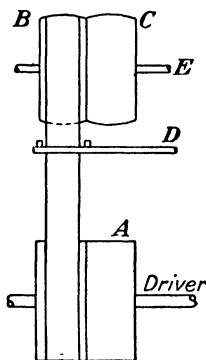

FIG. 134.

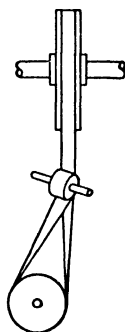

FIG. 135.

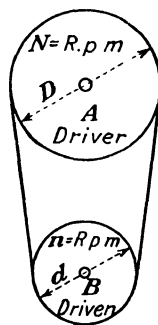

FIG. 136.

is making *n* r.p.m. Therefore, the linear speed of the pulley *A* will be  $\pi DN$  and that of *B* will be  $\pi dn$ . But since these pulleys are so connected that they must have the same surface speed, then

$$\pi DN = \pi dn$$

from which

$$DN = dn \quad \text{or} \quad \frac{D}{d} = \frac{n}{N} = \frac{2R}{2r} = \frac{R}{r}$$

That is, the revolutions of the pulleys are *inversely* proportional to the radii or to the diameters.

**Stepped, or Cone, Pulleys.**—If a belt which is driving a machine has but one pulley on the line shaft with the corresponding pulley on the machine, there will be but one speed at which the belt can run, provided that the speed of the line shaft is always the same. However, in most machines, such as lathes, shapers, drill presses, milling machines, and others, it is necessary to have a variety of speeds.

This variety can be obtained by placing several pulleys of different sizes on the line shaft and a corresponding set on the machine. If these sets of pulleys are cast in one piece, the device is known as a *stepped*, or *cone*, pulley.

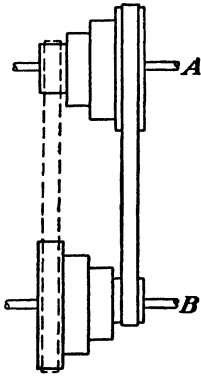

FIG. 137.

Figure 137 shows two pulleys of this kind as they would be placed on the shafts. If *A* is the driving shaft and the belt is in the position as shown, the shaft *B* will revolve a great many more times than *A*, since the number of revolutions is in inverse ratio to the diameters of the pulleys connected. On the other hand, if the belt were in a position such as that shown by the dotted lines, *B* would rotate at a much slower rate than *A* for the same reason as above. In this way, by making enough steps on the cones, any desired speed ratio between the shafts *A* and *B* can be obtained.

When such steps are used, they must be designed so that one length of belt will run in all the positions. In the case of crossed belts, the sum of the diameters of each pair of opposite steps must be equal. In open belts, however, the sum of the diameters of the intermediate steps should be a little greater than the sum of those of the outside steps. The calculations for these values are rather complex, and therefore they will not be taken up in this text.

**Ratios and Pulleys.**—As previously shown, when two pulleys are connected by a belt the speeds (r.p.m.) of the pulleys are in inverse ratio to their diameters. Suppose that a driving shaft is making 450 r.p.m. and that it is desired to connect it to a machine so that the machine pulley will make 300 r.p.m. If the machine is supplied with an 18-in. pulley, what size pulley must be used on the driving shaft?

Since

$$\frac{D}{d} = \frac{n}{N}$$

and

$$d = 18 \text{ in.}$$

$$N = 450 \text{ r.p.m.}$$

and

$$n = 300 \text{ r.p.m.}$$

then

$$\frac{D}{18} = \frac{300}{450}$$

from which

$$D = 12 \text{ in. Answer}$$

**Multiple Ratios.**—Sometimes the ratio of the number of revolutions between pulleys will be too large to permit them to be connected directly. For example, in this last problem suppose that the line shaft makes 450 r.p.m. and that it is desired to have the pulley on the machine make only 50 r.p.m. Here the ratio between the number of revolutions will be as 450 is to 50, or as 9 is to 1. This means that one pulley will have to be made nine times as large as the other. If an 8-in. pulley is chosen for the smaller one, the larger one will be  $9 \times 8 = 72$  in. It is quite evident that a pulley of this size would be too large and thus some other arrangement would have to be made. In cases of this kind another shaft known as an *auxillary* or *countershaft* is used so that the stepping-down process may be done in two stages and the size of the pulleys reduced.

Since the ratio between the pulleys on the line shaft and on the machine is 9 to 1, the ratio between the revolutions of the pulleys on the line shaft and the countershaft may be taken as 3 to 1, and the ratio between the pulleys on the countershaft and the machine may be taken as 3 to 1, since two ratios of 3 to 1 will give a combined ratio of 9 to 1. In Fig. 138, the size of neither the pulley on the line shaft *A* nor that on the countershaft *B* has been given; they may be assumed with the correct ratio of 3 to 1. An 8-in. pulley on *A* and a 24-in. pulley on *B* may be used. Now the ratio between the countershaft *B* and the machine *C* must also be 3 to 1, which shows that if the machine is supplied with an 18-in. pulley, as given in the problem, then the pulley on the countershaft must be 18 divided by 3, or 6 in.

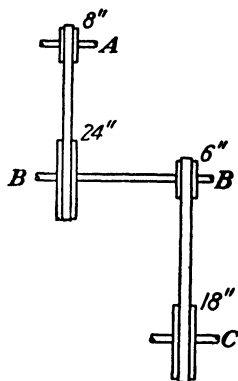

FIG. 138.

### Problems

85. An 18-in. pulley is belted directly to an 8-in. pulley. If the former makes 160 r.p.m., calculate the r.p.m. of the latter.

86. Two pulleys are belted together and make 180 and 270 r.p.m., respectively. If the latter pulley is 8 in. in diameter, what is the size of the other one?

87. Two shafts are connected by stepped cone pulleys, the sizes of the steps on each being 8, 10, 12, and 14 in. If one of these shafts revolves at a rate of 225 r.p.m., calculate the four speeds that the other shaft may rotate at. (Note:

Since each of these pulleys has the same-sized steps, they must be connected by a crossed belt.)

88. Figure 139 shows a line shaft connected to a grinder by means of a countershaft. The belt from the line shaft drives a 10-in. pulley on the countershaft, and another 24-in. pulley on the countershaft drives an 8-in. pulley on the grinder.

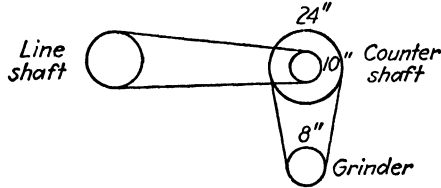

FIG. 139.

If the line shaft makes 225 r.p.m., what must be the size of its pulley in order to drive the grinder at 1,080 r.p.m.?

89. A line shaft making 220 r.p.m. is to be connected through a countershaft to a fan making 792 r.p.m. Select a pulley arrangement with a minimum diameter of 6 in.

**Gears and Gear Trains.**—Like pulleys and belts, gears are used to transmit power from one rotating shaft to another parallel rotating shaft by means of intermeshing teeth, which prevent any loss of power due to slipping which would occur if two smooth disks were in contact.

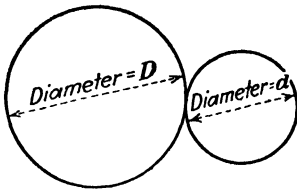

FIG. 140.

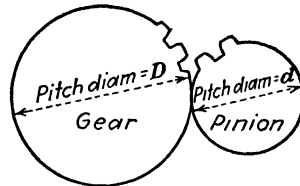

FIG. 141.

Figure 140 shows two smooth disks with their respective diameters  $D$  and  $d$ , which are in contact. Figure 141 shows two equivalent disks on which gear teeth have been cut. The diameters of the disks are now called *pitch diameters*, and are used in calculations of speed ratios.

Common spur gears are gears on which teeth are cut parallel to the axis of rotation.

In pairs of spur gears, in Fig. 141, the gear with the larger number of teeth is called the *gear*, while the gear with the smaller number of teeth is called the *pinion*.

In all ratios concerning the relative numbers of teeth on a gear and pinion, it must be kept in mind that the numbers of teeth are directly proportional to the pitch diameters.

Letting

$$T = \text{number of teeth on a gear}$$

and

$$t = \text{number of teeth on a pinion}$$

then

$$\frac{D}{d} = \frac{T}{t}$$

but in ratios involving the numbers of revolutions, or the numbers of revolutions per minute, the pitch diameters or the numbers of teeth are inversely proportional to the numbers of revolutions or revolutions per minute.

Then

$$\frac{D}{d} = \frac{\text{rev.}}{\text{REV.}}$$

or

$$\frac{D}{d} = \frac{\text{r.p.m.}}{\text{R.P.M.}}$$

and

$$\frac{T}{t} = \frac{\text{rev.}}{\text{REV.}}$$

or

$$\frac{T}{t} = \frac{\text{r.p.m.}}{\text{R.P.M.}}$$

*Example.*—The pitch diameters of a gear and pinion are  $\frac{72}{7}$  and  $\frac{24}{7}$  in., respectively. If the gear has 72 teeth, how many teeth are on the pinion?

$$\frac{D}{d} = \frac{T}{t}$$

or

$$t = \frac{T \times d}{D}$$

then

$$t = \frac{72 \times \frac{24}{7}}{\frac{72}{7}} = \frac{72 \times 24}{72} = 24 \text{ teeth}$$

In the same problem, when the gear turns 4 revolutions, how many revolutions will the pinion turn?

Generally, it will be easier to use the number of teeth when solving the ratios, as there cannot be a fractional part of a tooth on a gear. Thus

$$\frac{T}{t} = \frac{\text{rev.}}{\text{REV.}}$$

and

$$\text{rev.} = \frac{T \times \text{REV.}}{t}$$

then

$$\text{rev.} = \frac{72 \times 4}{24} = 12$$

If the pinion is rotating at 150 r.p.m., what is the speed (R.P.M.) of the gear?

$$\frac{T}{t} = \frac{\text{r.p.m.}}{\text{R.P.M.}}$$

and

$$\text{R.P.M.} = \frac{t \times \text{r.p.m.}}{T}$$

then

$$\text{R.P.M.} = \frac{24 \times 150}{72} = 50$$

When the axes of two shafts intersect, the power from one is transmitted to the other by *bevel gears*.

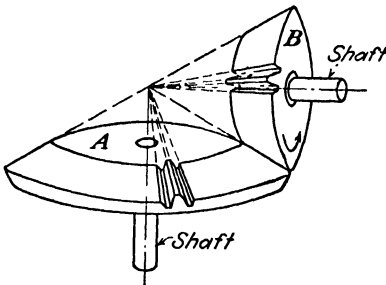

FIG. 142.

The teeth are constructed on the surfaces of two cones by alternately cutting recesses and adding projecting lugs. The principal difference between spur gears and bevel gears is that in the latter the teeth are tapered and come to a common point, while they are parallel to the axis in the spur gear (Fig. 142).

For bevel gears, the same ratios may be applied as for spur gears.

Thus

$$\frac{\text{Diam. of } A}{\text{diam. of } B} = \frac{\text{rev. of } B}{\text{Rev. of } A}$$

and

$$\frac{\text{Teeth on } A}{\text{teeth on } B} = \frac{\text{rev. of } B}{\text{Rev. of } A} = \frac{\text{r.p.m. of } B}{\text{R.P.M. of } A}$$

*Example.*—A pair of bevel gears have 60 and 24 teeth, respectively. If the smaller gear is rotating at 300 r.p.m., what is the r.p.m. of the larger gear?

$$\frac{\text{Teeth on } A}{\text{teeth on } B} = \frac{\text{r.p.m. of } B}{\text{R.P.M. of } A}$$

then

$$\frac{60}{24} = \frac{300}{x}$$

and

$$x = \frac{300 \times 24}{60}$$

from which

$$x = 120 \text{ R.P.M. (of the larger gear)}$$

**Rack and Gear Ratios.**—When the teeth are cut on the side of a straight bar, it is known as a *rack*, as shown in Fig. 143. A gear and

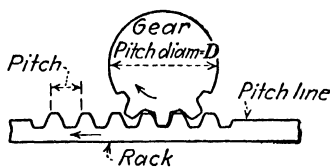

FIG. 143.

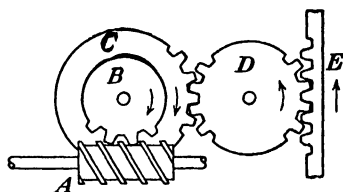

FIG. 144.

rack are used to transmit power from a rotating shaft to a straight bar, changing rotary motion to straight-line motion. As the teeth on the gear are in mesh with the teeth on the rack, it will be seen that the rack will move to the left a distance equal to the pitch of the rack times the number of teeth of the gear that pass the point of contact. Thus, if the gear has 21 teeth, and if it turns one complete revolution, the rack having a pitch of  $\frac{1}{4}$  in., the rack will move a

$$\text{Distance} = \text{teeth} \times \text{pitch} = 21 \times \frac{1}{4} = 3 \text{ in.}$$

*Example.*—A rack of  $\frac{1}{8}$ -in. pitch moves a distance of  $1\frac{1}{2}$  in. How many revolutions will a gear with 12 teeth make? The number of teeth to make contact will be

$$\text{teeth} = \frac{\text{distance}}{\text{pitch}} = \frac{1\frac{1}{2}}{\frac{1}{8}} = 9$$

and since there are 12 teeth on the gear, the revolutions will be

$$\text{revolutions} = \frac{\text{teeth making contact}}{\text{teeth on gear}} = \frac{9}{12} = \frac{3}{4}$$

In Fig. 144, a double-thread worm  $A$  meshes with a 64-tooth worm wheel  $B$ . Gear  $C$  is fastened to the same axle as  $B$ , and has 32 teeth. The pinion  $D$  has 12 teeth, and is meshed with the rack  $E$  having a pitch of  $\frac{1}{4}$  in. What distance does the rack move when the worm makes 8 revolutions?

As the worm is double-threaded, 1 revolution is equal to two teeth on the worm wheel; hence

$$\begin{aligned} \text{Number of teeth on the worm wheel} \\ = 8 \text{ rev.} \times 2 = 16 \text{ teeth (contacted)} \end{aligned}$$

$$\begin{aligned} \text{Number of revolutions of worm wheel } B \\ = \frac{\text{teeth contacted}}{\text{teeth in worm wheel}} = \frac{16}{64} = \frac{1}{4} \end{aligned}$$

As gear  $C$  is on the same shaft as the worm wheel, it turns  $\frac{1}{4}$  revolution. Then

$$\frac{T}{t} = \frac{\text{rev. of pinion}}{\text{Rev. of Gear}}$$

and

$$\frac{32}{12} = \frac{\text{rev. of pinion}}{\frac{1}{4}}$$

from which

$$\text{Rev.} = \frac{32 \times \frac{1}{4}}{12} = \frac{8}{12} = \frac{2}{3} \text{ (of pinion)}$$

Teeth on pinion making contact with rack

$$\begin{aligned} &= \text{rev. of pinion} \times \text{teeth on pinion} \\ &= \frac{2}{3} \times 12 = 8 \text{ (teeth on rack)} \end{aligned}$$

As the pitch of the teeth on the rack is  $\frac{1}{4}$  in., the rack moves upward

$$\frac{1}{4} \times 8 = 2 \text{ in. Answer}$$

With the exception of the last step, dealing with the rack, this may be combined.

$$\frac{\text{Rev. } A}{\text{Rev. } B} = \frac{\text{teeth on } B}{\text{teeth on } A}$$

and

Rev.  $B$  = Rev.  $C$ , as both  $B$  and  $C$  are on the same shaft,

then

$$\frac{\text{Rev. } C}{\text{rev. } D} = \frac{\text{teeth on } D}{\text{teeth on } C}$$

from which

$$\frac{\text{Rev. } A}{\text{rev. } D} = \frac{\text{teeth on } B \times \text{teeth on } D}{\text{teeth on } A \times \text{teeth on } C}$$

or

$$\frac{8}{\text{rev. } D} = \frac{64 \times 12}{2 \times 32}$$

therefore

$$\text{rev. } D = \frac{8}{12} = \frac{2}{3}$$

From the above, it should be noted that the ratio of the revolutions (or r.p.m.) of the first shaft is to the revolutions (or r.p.m.) of the last shaft as the ratio of the *product* of the number of teeth (or pitch diameters) of the *driven* wheels is to the product of the number of teeth (or pitch diameters) of the *drivers*.

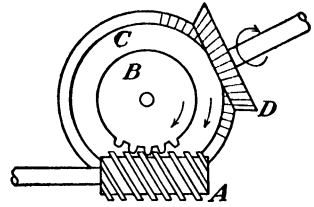

FIG. 145.

A driver is a wheel that is turning the driven wheel (or follower). In Fig. 144, the worm is a driver, and worm wheel *B* is its follower (or driven wheel). Gear *C* is the driver wheel and *D* is the driven wheel. In other words, motion is transmitted by *A* (driver) to *B* (driven) and by *C* (driver) to *D* (driven).

*Example.*—A triple-threaded worm *A* and a 60-tooth worm wheel *B* are shown in Fig. 145. On the same shaft as the worm wheel is fastened a 96-tooth bevel gear *C*; *D* is a 30-tooth bevel gear. When the shaft of the worm is rotating at 120 r.p.m., how many r.p.m. is the shaft of bevel gear *D* making?

$$\frac{\text{R.P.M. of } A}{\text{r.p.m. of } D} = \frac{\text{teeth on } B \times \text{teeth on } D}{\text{teeth on } A \times \text{teeth on } C}$$

then

$$\frac{120}{\text{r.p.m. of } D} = \frac{60 \times 30}{3 \times 96}$$

and

$$\text{r.p.m. of } D = \frac{120 \times 3 \times 96}{60 \times 30} = \frac{96}{5} = 19.2$$

**Problems**

In the following figures, the circles represent meshed gear wheels. In Fig. 146, gear *A* is to rotate at 50 r.p.m. and pinion *B* at 200 r.p.m. (problems 90, 91, and 92).

90. If *A* rotates clockwise, in what direction does *B* rotate?

91. If *B* has 20 teeth, how many teeth does *A* have?

92. If the shafts are 20 in. apart, what is the diameter of each gear? *Hint:* let  $x$  = radius of  $A$ ; then radius of  $B = 20 - x$ .

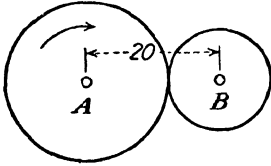

FIG. 146.

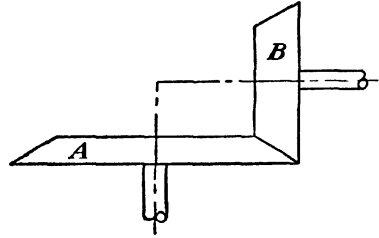

FIG. 147.

93. Bevel gear  $A$  has 48 teeth. How many teeth are on  $B$ ?

94. The pitch diameter of  $A$  is 12 in. What is the pitch diameter of  $B$ ?

95. A rack with  $\frac{1}{2}$ -in. pitch is to move a distance of  $3\frac{1}{2}$  in. If the gear that meshes with the rack makes  $1\frac{1}{2}$  revolutions, how many teeth are on the gear?

96. Bevel gear  $B$  and pinion  $C$  are fastened to a common shaft (Fig. 148). Bevel gear  $A$  has 24 teeth. Bevel gear  $B$  has 84 teeth. Pinion  $C$  has a 6-in.

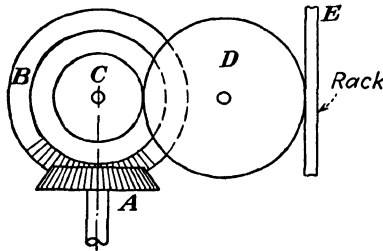

FIG. 148.

pitch diameter. Gear  $D$  has a 10-in. pitch diameter and 50 teeth. When the rack  $E$  moves 6 in., how many revolutions does bevel gear  $A$  make?

### TRAINS OF MECHANISMS

If two shafts are to be connected by gears and the required speed ratio between them is high, then in all probability one of the gears would have to be made inconveniently large, if but a single pair of gears be used. Such large gears can be avoided by inserting a counter-shaft and using two sets of gears instead of one. In this manner the speed ratio can be reduced on both pairs of gears so that each need be only half as large as one would have to be. When practical conditions make it necessary to use a series of gears or other devices, the arrangement is known as a *train of mechanism*.

In every pair of gears one of them is driving the other, so that one may be called the *driving gear*, or simply the *driver*, and the other the

*driven gear*, or the *follower*. These names are generally used to designate the different members of a train of mechanism.

**Gear Trains.**—A gear train consists of any number of gears used to transmit motion from one point to the other. The simplest form of gear train will be one having but two gears, and here the numbers of revolutions of the shafts will vary inversely with the pitch diameters.

Figure 149 shows a common arrangement of compound gearing. Here the gear *A* drives *B* and causes a certain reduction in the speed. Since *B* and *C* are fastened to the same shaft, they will rotate together. *C* drives *D* and causes further reduction in the speed. Let *A*, *B*, *C*, and *D* represent the diameters of these gears on the shafts 1, 2, and 3. Then the number of revolutions of shaft 1 will be to the number of revolutions of shaft 2 as *B* is to *A*.

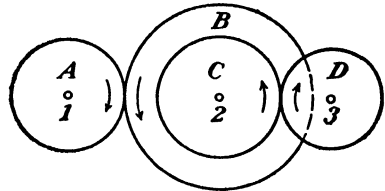

FIG. 149.

$$\frac{\text{Rev. 1}}{\text{Rev. 2}} = \frac{B}{A}$$

Also

$$\frac{\text{Rev. 2}}{\text{Rev. 3}} = \frac{D}{C}$$

Multiplying these expressions,

$$\frac{\text{Rev. 1}}{\text{Rev. 3}} = \frac{BD}{AC}$$

It will be noticed that both *B* and *D*, which are in the numerator, are followers, while *A* and *C*, which are in the denominator, are drivers. The rule follows, therefore, that in a train of gears the number of revolutions of the first shaft is to the number of revolutions of last shaft as the product of the diameters of the followers is to the product of the diameters of the drivers.

If, in Fig. 149, *A* is 6 in., *B* is 18 in., *C* is 8 in., and *D* is 24 in., then

$$\frac{\text{Rev. shaft 1}}{\text{Rev. shaft 3}} = \frac{18 \times 24}{6 \times 8} = 9$$

or shaft 1 must make 9 revolutions for every one of shaft 3.

**The Idler.**—Figure 150 shows another form of compound gearing in which but one gear is on each shaft. *A* drives *C* through the intermediate gear *B*, but the speed of *C* will be no different than if *A* were directly connected to *C*, since the linear speed of *B* must be the same

at all points. If *A* and *C* were connected directly, they would rotate in opposite directions, but when connected with an intermediate shaft and gear, as shown in this figure, they will rotate in the same direction.

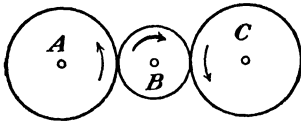

FIG. 150.

Such an intermediate wheel in a train is called an *idler*. The idler acts as both driver and follower.

In all the speed discussions, whenever the relations between the number of revolutions of connected rotating bodies have been considered, it has always been shown that the revolutions vary inversely as the diameters. There are, however, other and somewhat simpler methods that may be used here to advantage. In the discussion on gears, it was shown that the number of teeth was always a function of the diameter of the gear. Therefore, the numbers of teeth on two gears in mesh have the same relation as their diameters, so that it may be said that the numbers of revolutions are in inverse ratio to the numbers of teeth.

Since gears are generally designated by the number of teeth and not by the diameters it will be found more convenient to use this latter method in solving for revolutions.

**Directional Relation.**—The relation existing between the direction of rotation of any two members in a train depends on the number and manner of connections between them. If all the shafts are parallel to each

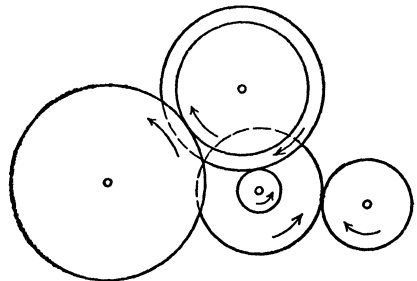

FIG. 151.

other and all the gears are spur gears, as in Fig. 151, the direction of motion of each shaft will be opposite to that of the one adjacent to it. In any arrangement of this kind, the directional relation may be traced by placing arrows on the different wheels showing their direction of rotation. A further study of the figure will show that when the number of shafts in the train is even, the last number will rotate in the opposite direction to the first; but if there is an odd number of shafts, the direction of rotation of the last will be the same as that of the first.

Figure 152 shows a train of mechanism in which has been introduced a pair of beveled gears and a worm and wheel. Here the beveled gears will be treated exactly the same as spur gears, since

the same properties hold true for both. The worm wheel, however, needs special treatment. It is obvious that the diameter of the worm has nothing to do with its speed relation to the gear  $F$ , since the motion it gives to the gear  $F$  depends only on the lead of the worm. Therefore the relation that the number of revolutions varies inversely as the diameters cannot be used. But if the relation between the number of teeth is used, the solution becomes possible. If  $E$  is a single-threaded worm, then it may be considered as having one tooth

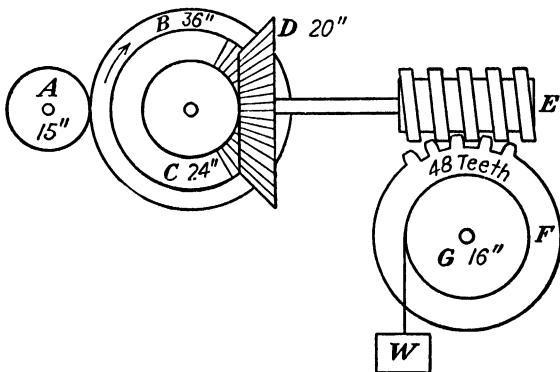

FIG. 152.

on it, so that if the revolutions vary inversely as the number of teeth, then

$$\frac{\text{Rev. } E}{\text{Rev. } F} = \frac{\text{no. teeth on } F}{1}$$

**Problem.**—In Fig. 152, the driver  $A$  makes 100 r.p.m. How much will the weight  $W$  be raised or lowered per minute?

$$\frac{\text{Rev. shaft } A}{\text{Rev. shaft } G} = \frac{B \times D \times F}{A \times C \times E} = \frac{36 \times 20 \times 48}{15 \times 24 \times 1} = \frac{96}{1}$$

That is, shaft  $A$  must make 96 revolutions for shaft  $G$  to make 1. Therefore, when shaft  $A$  or the gear  $A$  makes 100 revolutions, shaft  $G$  will make

$$\frac{100}{96} = 1\frac{1}{24} \text{ r.p.m.}$$

Now the circumference of the drum  $G$  will be  $\pi D$ , or  $3.1416 \times 16 = 50.24$  in. Hence,  $1\frac{1}{24} \times 50.24 = 52.33$  in., which is the required answer. The weight will be raised.

**Lathe Trains.**—One of the most important uses of a train of gears is that found in the ordinary engine lathe as used for cutting threads.

The lathe carriage and tool are moved by a lead screw that usually has 4, 6, or 8 threads per inch on it. If a lathe has a lead screw having

4 threads per inch upon it, each revolution of the lead screw will move the carriage  $\frac{1}{4}$  in. If the spindle of the lathe revolves at the same rate as the lead screw, the tool will cut a thread of the same pitch as that on the lead screw, in this case 4 threads per inch. If a finer thread than that on the lead screw is desired, the spindle will be made to rotate faster than the lead screw.

Suppose that it is required to cut 12 threads per inch, using the same  $\frac{1}{4}$ -in. lead screw. It will require 4 turns of the lead screw to move the carriage 1 in., and meanwhile the spindle must rotate 12 times. Then the ratio of lead-screw speed to spindle speed will be 1 to 3.

$$\frac{\text{Revolutions of spindle}}{\text{Revolutions of lead screw}} = \frac{\text{threads per inch to be cut}}{\text{threads per inch on lead screw}}$$

The train is laid out in such a manner that the revolutions of the spindle are to the revolutions of the lead screw as the product of the followers is to the product of the drivers. Or

$$\frac{\text{product of followers}}{\text{product of drivers}} = \frac{\text{threads per inch to be cut}}{\text{threads per inch on lead screw}}$$

The gears in the train may be chosen, then, so as to cut any desired number of threads.

### Problems

97. In Fig. 149, if  $A$  equals 12 in.,  $B$  equals 22 in.,  $C$  equals 9 in., and  $D$  equals 27 in., and if  $A$  makes 86 r.p.m. right-handed, find the direction and r.p.m. of  $D$ .
98. In Fig. 149, if  $A$  has 24 teeth,  $B$  has 44 teeth,  $C$  has 20 teeth, and  $D$  has 36 teeth, and if  $A$  makes 120 r.p.m., find the r.p.m. of  $D$ .
99. In Fig. 152,  $A$  equals 8 in.,  $B$  equals 18 in.,  $C$  has 24 teeth,  $D$  has 44 teeth,  $E$  is a single-threaded worm, and  $F$  has 42 teeth. How many revolutions will  $F$  make for 100 revolutions of  $A$ ?

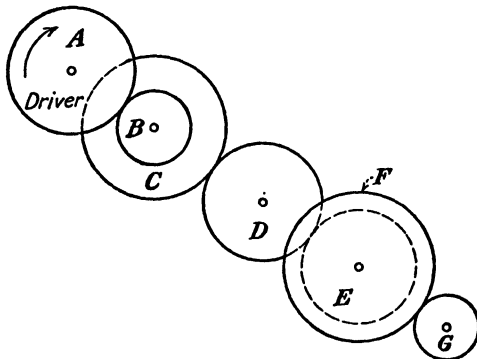

FIG. 153.

100. If, in problem 99, *E* is a triple-threaded worm, how many revolutions will *F* make? If *A* turns counterclockwise, in what direction will *F* turn?

The train of mechanism in Fig. 153 has the following data, which are to be used in problems 101, 102, 103, and 104.

	Pitch diameter	Teeth
Gear <i>A</i> .....	15 in.	30
Gear <i>B</i> .....	7½ in.	15
Gear <i>C</i> .....	20 in.	40
Gear <i>D</i> .....	18 in.	36
Gear <i>E</i> .....	10 in.	20
Gear <i>F</i> .....	12 in.	24
Gear <i>G</i> .....	6 in.	12

101. If *A* is rotating clockwise, what is the direction of rotation of *G*?

102. When *A* is rotating at 60 r.p.m., how fast is *G* rotating? Use the number of teeth in making this calculation.

103. Using the pitch diameters in making this calculation, how fast is *G* rotating when *A* is rotating at 60 r.p.m.?

104. When *A* rotates 100 revolutions, how many revolutions has *G* made?

## CHAPTER VI

### FRICTION AND THE INCLINED PLANE

Friction is a force which acts between two surfaces in contact, and which tends to resist motion. It is a force that acts only when an effort is made to slide one body over the other. *Static friction* is the force of friction which acts when the body is stationary (at rest), while *kinetic friction* is the force of friction which acts when the body is moving. However, both kinds of friction are given the same consideration, the static friction being greater than the kinetic friction for the same surfaces in contact.

It has been shown that there is a constant ratio of the maximum friction force which may be developed to the normal (or perpendicular) pressure between the bodies. This ratio is called the *coefficient of friction* and will be represented by the letter  $f$ .

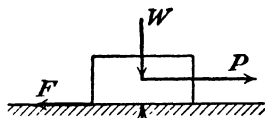

FIG. 154.

Considering a body weighing  $W$  pounds resting on a horizontal surface, we notice that the *normal pressure* or the *normal reaction* of the surface on the body is the same as the weight of the body.

Then the *coefficient of friction* is the ratio of the maximum friction force (represented by  $F$ ) to the normal reaction (represented

by  $N$ ). Thus the coefficient of friction  $f = \frac{F}{N}$ , which is true for any

body resting on any surface whether horizontal or inclined.

When a body, as shown in Fig. 154, is resting on a horizontal surface, the upward push of the surface against the body must equal the downward push of the body on the surface. Also, the horizontal pull will equal the maximum friction force  $F$  just before motion takes place toward the right. Friction always opposes motion, and hence, in all cases, it is directed opposite to the direction in which motion is to take place (called *impending motion*).

The coefficient of friction varies in its amount, depending on the material of the surfaces of contact. Several coefficients of static friction are

Wood on wood.....	0 2 to 0 5
Wood on metal.....	0 2 to 0 6
Metal on metal.....	0 15 to 0 25

A casting weighing 50 lb. is resting on a wood floor. What force parallel to the horizontal floor is required to just start the casting sliding if the coefficient of friction between the floor and the casting is 0.4?

From Fig. 154 it will be seen that the weight of the body equals the normal reaction; hence

$$W = N = 50 \text{ lb.}$$

From

$$f = \frac{F}{N},$$

the maximum force of friction

$$F = fN$$

then

$$F = 0.4 \times 50 = 20 \text{ lb.}$$

As the required pull must overcome the friction,  $P = F$  just before sliding takes place; hence  $P = 20$  lb., which means that a pull slightly greater than 20 lb. will start the casting moving.

The maximum friction force is often called the *limiting friction force*. However, the actual friction force that can be developed may be anything from zero to the maximum value, depending on the conditions of the problem. Referring to Fig. 154 and the 50-lb. casting in the above example, what friction force is developed when a pull of 10 lb. is applied? As the weight is at rest, as before,

$$W = N = 50 \text{ lb.}$$

and from an  $H = 0$  equation,

$$+P - F = 0$$

where

$$P = 10 \text{ lb.},$$

then

$$\begin{aligned} +10 - F &= 0 \\ F &= 10 \text{ lb.} \end{aligned}$$

which is the greatest friction force which can be developed under the conditions stated. When motion takes place, the limiting, or maximum, friction force is always developed. It will be assumed that all the discussion and problems which follow refer to the development of the maximum friction forces unless other conditions are specified.

When the applied pull is in a direction at an angle of  $a$  degrees (Fig. 155) above the horizontal floor on which the body is resting, the

effect is to lift the body partially from the floor, resulting in a smaller normal reaction and, consequently, a smaller force of friction.

From the illustration of a similar body (Fig. 154) resting on a horizontal floor, it will be noted that when a pull, parallel to the floor, is applied, the horizontal forces balance and the vertical forces balance; that is, the horizontal forces  $P$  and  $F$  are equal, and the vertical forces  $W$  and  $N$  are equal.

Now, as the pull is applied at an angle with the horizontal, it will be necessary to resolve it into two components, one parallel to the floor and the other perpendicular to the floor (vertical), which is shown in Fig. 156.

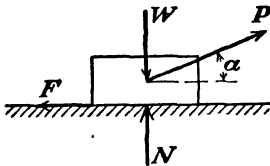

FIG. 155.

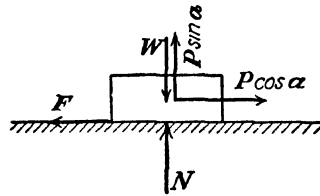

FIG. 156.

Keeping in mind that the vertical forces must be in equilibrium, their sum must equal zero or

$$N + P \sin a - W = 0$$

from which

$$N = W - P \sin a$$

Likewise, the horizontal forces must be in equilibrium, and their sum must equal zero.

$$P \cos a - F = 0$$

but as

$$F = fN$$

then

$$P \cos a = fN \quad \text{or} \quad P \cos a = f(W - P \sin a)$$

A casting weighing 50 lb. is resting on a wood floor. It is to be pulled by a force making an angle of  $20^\circ$  upward with the floor. When the coefficient of friction is 0.4, what pull is necessary just to start the body moving?

From tables

$$\begin{array}{l} \sin 20^\circ = 0.342 \quad \text{and} \quad \cos 20^\circ = 0.940 \\ N = W - P \sin 20^\circ \quad \text{or} \quad N = 50 - 0.342P \end{array}$$

and

$$P \cos 20^\circ = fN \quad \text{or} \quad 0.940P = 0.4(50 - 0.342P)$$

Solving

$$\begin{aligned} 0.940P &= 20 - 0.1368P \\ 0.940P + 0.1368P &= 20 \quad \text{and} \quad 1.0768P = 20 \end{aligned}$$

from which

$$P = 18.57 \text{ lb.}$$

By comparison with the example on page 77, it will be noted that less pull is required (18.57 lb. < 20 lb.) to develop the maximum friction force. Thus, when the pull is applied at an angle with the plane on which the body is resting, the pull decreases as the angle increases until a minimum value of the pull is reached, after which it

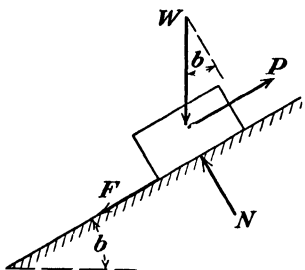

FIG. 157.

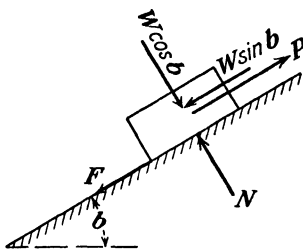

FIG. 158.

increases. (The angle of minimum pull is equivalent to the angle of repose which is explained on page 83.)

Figure 157 shows a body weighing  $W$  pounds resting on a plane inclined to the horizontal at an angle  $b$ . The direction of impending motion is upward, which results in the force of friction  $F$  acting downward along the plane as shown. As in the previous explanations, the forces parallel to the *plane* on which the body is resting must be balanced and the forces perpendicular to the *plane* must be balanced.

Resolving the weight  $W$  into two components (Fig. 158), one parallel to the inclined plane and the other perpendicular to the inclined plane, the components are  $W \sin b$ , downward parallel to the plane and  $W \cos b$  downward perpendicular to the inclined plane. As the forces  $N$  and  $W \cos b$  are the only forces perpendicular to the incline, they must be in equilibrium; hence

$$N = W \cos b$$

There are three forces parallel to the incline:  $P$  upward, and  $W \sin b$  and  $F$  downward.

$$P = W \sin b + F$$

As

$$F = fN$$

then

$$P = W \sin b + fN$$

but

$$N = W \cos b$$

therefore

$$P = W \sin b + f(W \cos b)$$

A weight of 50 lb. is to be started up a plane inclined at an angle of  $30^\circ$  above the horizontal by a pull  $P$  applied parallel to the incline. The coefficient of friction between the plane and the weight is 0.4. What pull is necessary to just start the body?

From tables

$$\sin 30^\circ = 0.500 \quad \text{and} \quad \cos 30^\circ = 0.866$$

$$N = W \cos b \quad \text{or} \quad N = 50 \times 0.866 = 43.3$$

and

$$P = W \sin b + F \quad \text{or} \quad P = W \sin 30^\circ + fN$$

then

$$P = 50 \times 0.500 + 0.4 \times 43.3 = 25 + 17.32$$

and

$$P = 42.32 \text{ lb.}$$

Figure 159 shows a body of weight  $W$  lb. which is resting on an inclined plane and which is to be pulled up the incline by a pull  $P$

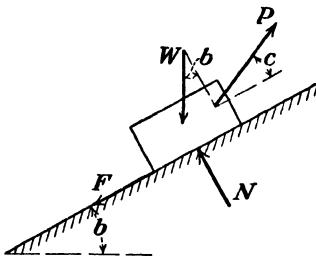

FIG. 159.

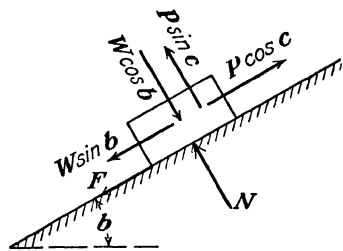

FIG. 160.

applied at an angle  $c$  with the incline. The difference between this case and the preceding case is in the direction of the applied pull  $P$ .

It is necessary to resolve the force  $P$  into two components (Fig. 160), one of which is parallel to the incline and the other perpendicular

to the incline. These components are  $P \cos c$  (parallel to the plane) and  $P \sin c$  (perpendicular to the plane).

As in the preceding case of a body resting on an inclined plane, the weight  $W$  must be resolved into its components.

There are three forces acting on the body perpendicular to the incline, which when balanced show

$$N + P \sin c = W \cos b$$

from which

$$N = W \cos b - P \sin c$$

Likewise, there are three forces parallel to the incline.

$$P \cos c = W \sin b + fN$$

or

$$P \cos c = W \sin b + fN$$

since

$$\begin{aligned} N &= W \cos b - P \sin c, \\ P \cos c &= W \sin b + f(W \cos b - P \sin c). \end{aligned}$$

A 50-lb. weight is resting on a  $30^\circ$  incline. If the coefficient of friction between the plane and the weight is 0.4, what pull making an angle of  $20^\circ$  with the incline will just start the body moving up?

$$\begin{aligned} N &= W \cos b - P \sin c = 50 \times 0.866 - P \times 0.342 \\ &= 43.3 - 0.342P \end{aligned}$$

$$P \cos c = W \sin b + fN$$

or

$$0.940P = 50 \times 0.500 + 0.4(43.3 - 0.342P)$$

$$0.940P = 25 + 17.32 - 0.1368P$$

and

$$0.940P + 0.1368P = 42.32$$

$$1.0768P = 42.32$$

$$P = 39.30 \text{ lb.}$$

In comparing this amount with the amount of the pull required for the example on page 80, it should be noted that the amount of pull is less when an upward pull is applied at an angle with the inclined plane, as previously explained.

In Fig. 161, in which the body weighing  $W$  lb. rests on the inclined plane, the angle of inclination of the plane is to be increased gradually until the body starts to slide down. As the impending motion is

downward, the force of friction, which always opposes motion, is directed upward. No pull is to be applied to the weight.

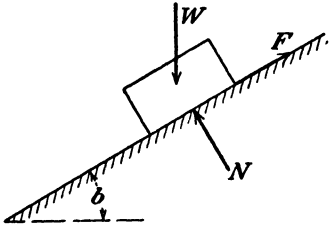

FIG. 161.

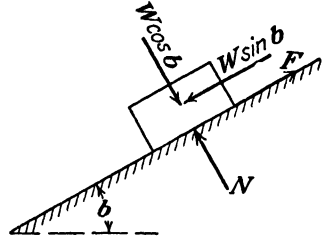

FIG. 162.

Resolving the weight  $W$  into its components parallel and perpendicular to the incline, as shown in Fig. 162, and balancing the forces in directions parallel and perpendicular to the incline, we have

$$\text{(perpendicular)} \quad N = W \cos b$$

$$\text{(parallel)} \quad W \sin b = F$$

or

$$W \sin b = fN$$

Since

$$N = W \cos b$$

then

$$W \sin b = fW \cos b$$

from which

$$f = \frac{W \sin b}{W \cos b}$$

From trigonometry, in a right triangle

$$\sin b = \frac{\text{opposite side}}{\text{hypotenuse}} \quad \text{and} \quad \cos b = \frac{\text{adjacent side}}{\text{hypotenuse}}$$

dividing the  $\sin b$  by the  $\cos b$ ,

$$\left. \begin{array}{l} \sin b = \frac{\text{opposite side}}{\text{hypotenuse}} \\ \cos b = \frac{\text{adjacent side}}{\text{hypotenuse}} \end{array} \right\} \frac{\sin b}{\cos b} = \frac{\text{opposite side}}{\text{adjacent side}} = \tan b$$

Therefore

$$f = \frac{W \sin b}{W \cos b} = \tan b$$

Thus, when the tangent of the angle of inclination is equal to the coefficient of friction, the body is just on the point of starting to slide down the incline. This angle is known as the angle of repose. ( $\angle$  of friction)

When the impending motion is down the incline, it must be noted that the force of friction is directed up the incline. If a downward pull parallel to the incline must be applied for impending motion, the balancing of the forces parallel to the plane on which the body is resting should not present any difficulty in the solution.

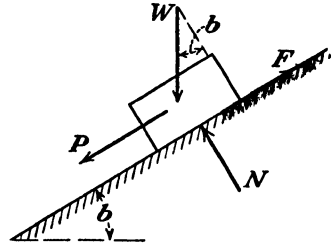

FIG. 163.

In Fig. 163, if the motion is downward, the forces parallel to the incline are balanced.

$$P + W \sin b = F$$

**Problems**

105. A casting weighing 60 lb. rests on a horizontal floor. A horizontal pull of 23.4 lb. is required to make it slide along the floor. What is the coefficient of static friction?

106. A box and its contents, which weigh 200 lb., are pulled on a horizontal floor for which the coefficient of friction is 0.3 by a horizontal force  $P$ . What is the amount of the force necessary to start the box? If the force  $P$  is made 40 lb., what is the amount of the friction force developed?

107. If the pull in problem 106 is at an angle of  $18^{\circ}20'$  above the horizontal, what pull is required to start the box?

108. A 75-lb. block of steel is pulled up a  $20^{\circ}$  incline by a force  $P$  parallel to the incline. What force is required when the coefficient of friction is 0.41? What friction force is developed when the angle of inclination is  $10^{\circ}$ ?

109. If the force in problem 108 is directed upward at an angle of  $30^{\circ}$  with the inclined plane, what pull is required to start the block?

110. A body weighing 36 lb. is resting on a plane, and the plane is gradually inclined to the horizontal until the body just starts to slide. The coefficient of friction is 0.32. At what angle of inclination does the body start to slide?

111. A weight of 120 lb. is to be pulled down a  $15^{\circ}$  incline by a force parallel to the incline. The coefficient of friction is 0.4. What pull is necessary to start the weight? If after the weight has been started the coefficient of kinetic friction is 0.35, what pull is required?

112. A horizontal force of 8 lb. is required to start a body weighing 22 lb. in motion along a horizontal plane. After it is started, a horizontal force of 7.5 lb. will keep it in motion. What are the coefficients of static and kinetic friction?

113. A body that weighs 30 lb. rests on a plane inclined at  $40^{\circ}$  with the horizontal. The coefficient of friction between the inclined plane and the body is 0.268. What force parallel to the incline is required to start the body moving up the incline?

114. In Fig. 164,  $W = 200$  lb. What force  $P$  is necessary just to start the block moving up the incline?  $157.0$  lb.

115. In Fig. 164,  $W = 200$  lb. What is the amount of the force  $P$  that will just prevent the block from sliding down the incline?

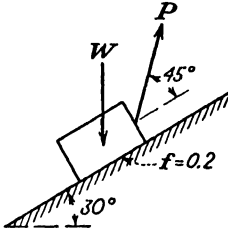

FIG. 164.

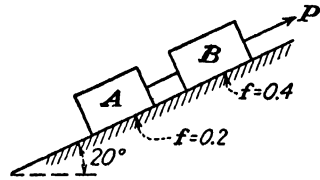

FIG. 165.

116. In Fig. 165, body  $A$  weighs 100 lb. and body  $B$  weighs 200 lb. What pull parallel to the inclined plane is required to start the bodies moving up the incline?

117. In Fig. 165, if no force  $P$  is applied, will the bodies remain at rest, or will they start to slide down the inclined plane? Use the weights given in problem 114.

## CHAPTER VII

### CENTROIDS

In the previous discussion of the method of locating the resultant force of a system of parallel forces in one plane, it was shown that

$$\bar{x} = \frac{P_1x_1 + P_2x_2 + P_3x_3 + \text{etc.}}{P_1 + P_2 + P_3 + \text{etc.}} \quad (\text{see Fig. 166})$$

The center of gravity of a solid body is defined as the point through which the resultant weight passes, or all the weight may be considered to be concentrated. In engineering practice, the term *centroid* is applied to areas, and the term *center of gravity* is applied to solids. The discussion here will be strictly confined to areas; hence the term *centroid* will be used.

If we consider that  $P_1$  is applied at the center of the block and represents the weight of a block of material, such that  $P_1 = W_1$ , and similarly that

$$P_2 = W_2, \quad P_3 = W_3, \text{ etc.},$$

the equation above becomes

$$\bar{x} = \frac{W_1x_1 + W_2x_2 + W_3x_3 + \text{etc.}}{W_1 + W_2 + W_3 + \text{etc.}}$$

When the blocks have uniform thickness such that

$$t_1 = t_2 = t_3 = \text{etc.}$$

and the material of all of the blocks is the same, then, letting  $A$  = area of block 1, etc., the above equations become

$$\bar{x} = \frac{A_1x_1 + A_2x_2 + A_3x_3 + \text{etc.}}{A_1 + A_2 + A_3 + \text{etc.}}$$

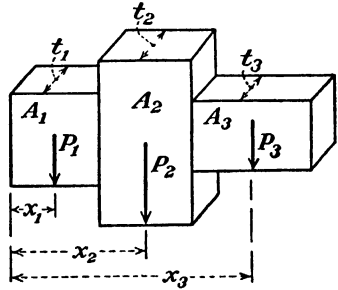

FIG. 166

which is the equation for locating the centroid of an area composed of a number of smaller areas, each of which has a known centroid.

Any area, such as  $A_2$ , can be considered as a negative area when it is to be subtracted from the over-all figure to give the net composite area. In this case, the negative sign appears with the  $A_2$  term in the numerator and the denominator of the above equation.

In locating the centroid of a composite area, the area should be divided into the most convenient number of geometrical areas (such as rectangles, triangles, circles, and semicircles) *each* of which has a known centroid.

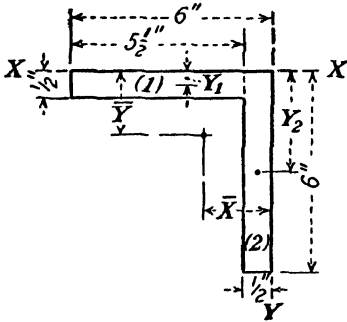

FIG. 167.

Let it be required to locate the centroid of a steel angle section, 6 in.  $\times$  6 in.  $\times$   $\frac{1}{2}$  in. from the back of the angle. We might consider that we are locating the centroid of a piece of cardboard of uniform thickness, the shape being that shown in Fig. 167. Using the  $x-x$  axis as the reference line, and dividing the area into a horizontal rectangle  $5\frac{1}{2}$  in.  $\times$   $\frac{1}{2}$  in. and a vertical rectangle 6 in.  $\times$   $\frac{1}{2}$  in., the centroid of each rectangle will be at its own center. Hence, applying the moment equation,

$$\bar{y} = \frac{A_1 y_1 + A_2 y_2}{A_1 + A_2}$$

where the  $y$  distances are measured in a vertical direction.

$$\begin{aligned} A_1 &= 5\frac{1}{2} \times \frac{1}{2} = 2.75 \text{ sq. in.}; & y_1 &= \frac{1}{4} \text{ in.} \\ A_2 &= 6 \times \frac{1}{2} = 3.00 \text{ sq. in.}; & y_2 &= 3 \text{ in.} \\ \bar{y} &= \frac{2.75 \times \frac{1}{4} + 3.00 \times 3}{2.75 + 3.00} = \frac{0.6875 + 9.00}{5.75} \\ &= \frac{9.6875}{5.75} = 1.68 \text{ in.} \end{aligned}$$

Using the same rectangular parts, and locating the centroid from the  $y-y$  axis, we have the equation

$$\bar{x} = \frac{A_1 x_1 + A_2 x_2}{A_1 + A_2}$$

where

$$\begin{aligned}
 A_1 &= 5\frac{1}{2} \times \frac{1}{2} = 2.75 \text{ sq. in.}; & x_1 &= \frac{1}{2} + \frac{1}{2}(5\frac{1}{2}) = 3.25 \text{ in.} \\
 A_2 &= 6 \times \frac{1}{2} = 3.00 \text{ sq. in.}; & x_2 &= \frac{1}{4} \text{ in.} \\
 \bar{x} &= \frac{2.75 \times 3.25 + 3.00 \times \frac{1}{4}}{2.75 + 3.00} = \frac{8.9375 + 0.75}{5.75} \\
 &= \frac{9.6875}{5.75} = 1.68 \text{ in.}
 \end{aligned}$$

As the angle section is symmetrical about each of the  $x-x$  and  $y-y$  axes, the distances from either axis to the centroid should be the same, which is the case, as shown by

$$\bar{y} = \bar{x} = 1.68 \text{ in.}$$

**Triangles.**—From geometry, we learn that the medians of any triangle will intersect in a common point  $D$ , which is the centroid of

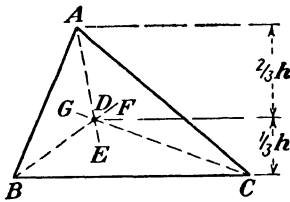

FIG. 168.

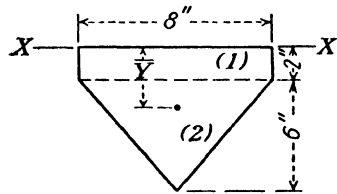

FIG. 169.

the triangle, as shown in Fig. 168. It can be shown, also, by the use of more advanced mathematics that the point  $D$  is located at a distance equal to one-third of the perpendicular altitude of the triangle, as measured from any side to the opposite vertex. If in Fig. 168 we let  $h$  represent the perpendicular altitude as measured from the base  $BC$ , then  $D$  is  $\frac{1}{3}h$  from  $BC$  or  $\frac{2}{3}h$  from the vertex  $A$ . Thus it can be said that the centroid of any triangle is at a distance of  $\frac{1}{3}h$  from the base or  $\frac{2}{3}h$  from the vertex.

As an example, let it be required to locate the centroid of the area shown in Fig. 169 from the  $x-x$  axis. Dividing the figure into a rectangle (1) 8 in.  $\times$  2 in. and a triangle (2) of 8-in. base and 6-in. altitude, we note that the centroid of each part may be located readily.

Using the equation,

$$\bar{y} = \frac{A_1 y_1 + A_2 y_2}{A_1 + A_2}$$

where

$$A_1 = 8 \times 2 = 16 \text{ sq. in.}; \quad y_1 = 1 \text{ in.}$$

$$A_2 = \frac{1}{2}(8 \times 6) = 24 \text{ sq. in.}; \quad y_2 = 2 \text{ in.} + \frac{1}{3}(6) = 4 \text{ in.}$$

$$\bar{y} = \frac{16 \times 1 + 24 \times 4}{16 + 24} = \frac{16 + 96}{40} = \frac{112}{40} = 2.8 \text{ in.}$$

**Circles and Semicircles.**—The centroid of a circle will be at its center  $O$ , as shown in Fig. 170. This can be checked experimentally

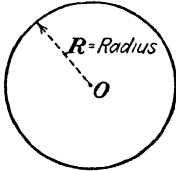

FIG. 170.

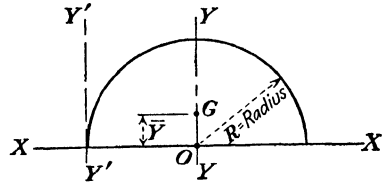

FIG. 171.

by cutting a circle carefully from a piece of cardboard of uniform thickness and then balancing it on a pin point when the pin point is placed at the center of the circle.

In the semicircle of radius  $R$  shown in Fig. 171, the centroid  $G$  will be located on the  $y-y$  axis at some distance  $\bar{y}$  from the  $x-x$  axis.

Again, if higher mathematics is used, the distance  $\bar{y}$  will be found to be

$$\bar{y} = \frac{4R}{3\pi} \quad \text{from the } x-x \text{ axis.}$$

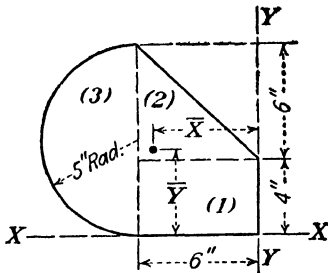

FIG. 172.

The  $y-y$  axis passes through the center  $O$  from which the semicircle is drawn and is perpendicular to the  $x-x$  axis. Thus the centroid  $G$  is at a distance of  $R$  from the  $y'-y'$  axis.

In Fig. 172, locate the centroid from the  $x-x$  and  $y-y$  axes of the composite area composed of a semicircle, rectangle, and triangle.

Solving for  $\bar{y}$  from the  $x-x$  axis,

$$A_1 = 4 \times 6 = 24 \text{ sq. in.}; \quad y_1 = 2 \text{ in.}$$

$$A_2 = \frac{1}{2}(6 \times 6) = 18 \text{ sq. in.}; \quad y_2 = 4 + \frac{1}{3}(6) = 6 \text{ in.}$$

$$A_3 = \frac{1}{2}(\pi 5^2) = 39.27 \text{ sq. in.}; \quad y_3 = 5 \text{ in.}$$

$$\bar{y} = \frac{24 \times 2 + 18 \times 6 + 39.27 \times 5}{24 + 18 + 39.27}$$

$$= \frac{48 + 108 + 196.35}{81.27} = \frac{352.35}{81.27}$$

$$= 4.34 \text{ in.}$$

Solving for  $\bar{x}$  from the  $y$ - $y$  axis,

$$A_1 = 4 \times 6 = 24 \text{ sq. in.}; \quad x_1 = 3 \text{ in.}$$

$$A_2 = \frac{1}{2}(6 \times 6) = 18 \text{ sq. in.}; \quad x_2 = \frac{2}{3}(6) = 4 \text{ in.}$$

$$A_3 = \frac{1}{2}(\pi 5^2) = 39.27 \text{ sq. in.}; \quad x_3 = 6 + \frac{4 \times 5}{3\pi} = 6 + 2.12 = 8.12 \text{ in.}$$

$$\begin{aligned} \bar{x} &= \frac{24 \times 3 + 18 \times 4 + 39.27 \times 8.12}{24 + 18 + 39.27} \\ &= \frac{72 + 72 + 318.87}{81.27} = \frac{462.87}{81.27} \\ &= 5.70 \text{ in.} \end{aligned}$$

As calculated, the centroid of the area is 5.70 in. from the  $y$ - $y$  axis and 4.34 in. from the  $x$ - $x$  axis.

**Problems**

118. Solve  $\bar{y}$  of Fig. 173.

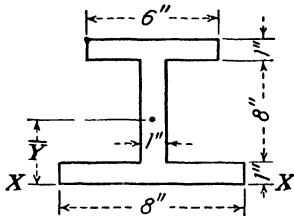

FIG. 173.

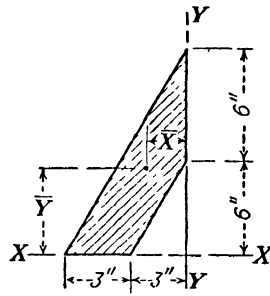

FIG. 174.

119. (a) Solve  $\bar{x}$  of Fig. 174.

(b) Solve  $\bar{y}$  of Fig. 174.

120. Solve  $\bar{y}$  of Fig. 175.

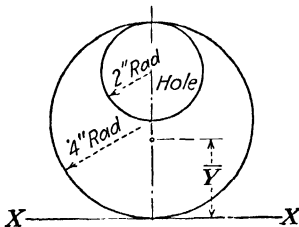

FIG. 175.

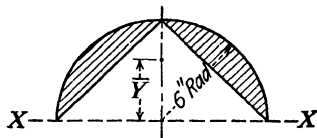

FIG. 176.

121. Solve  $\bar{y}$  of the shaded area of Fig. 176.



## CHAPTER VIII

### MOMENT OF INERTIA

A mathematical expression, which is sometimes defined as an index of the strength of structural members, is often encountered in the design of such members or parts. This expression is called the *moment of inertia*. Attention should be drawn to the fact that the design of the various parts of a machine or structure is based upon the cross-sectional area of such parts and not upon the part as a solid body.

The moment of inertia of an area about an axis is equivalent to the sums of the products obtained by dividing the given areas into an infinitely large number of small areas and multiplying *each* of the

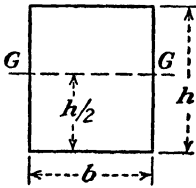

FIG. 181.

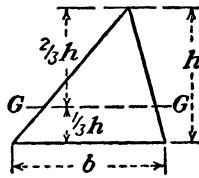

FIG. 182.

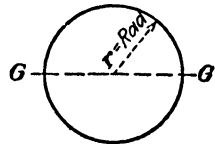

FIG. 183.

*small areas* by the *square* of its *distance* from the axis. As the process of obtaining the sum of these products for any one area involves higher mathematics, it will be sufficient to state the formulas that result from such processes of multiplication and addition by listing them for the areas most frequently encountered in engineering work, namely, the rectangle, the triangle, and the circle. As the most useful axis of moment of inertia is the axis passing through the centroid of the area, the formulas are

$$I_o = \frac{bh^3}{12}$$

for a rectangle of base  $b$  and altitude  $h$ , where  $I_o$  represents the moment of inertia of the rectangle about the  $G$ - $G$  axis, which is parallel to the base and which passes through the centroid (see Fig. 181).

The moment of inertia of a triangle of base  $b$  and altitude  $h$  about an axis through the centroid parallel to the base is

$$I_o = \frac{bh^3}{36}$$

The moment of inertia of a circle of radius  $r$  about any diameter, since every diameter passes through the centroid, is

$$I_o = \frac{\pi r^4}{4}$$

The units of moment of inertia are inches to the fourth power. These units are essential when the result of moment of inertia is applied to formulas for the design of structural members.

*Example.*—What is the moment of inertia of a rectangle with base = 6 in. and altitude = 12 in. about an axis through the centroid parallel to the base?

Given:  $b = 6$  in., and  $h = 12$  in.

$$I_o = \frac{bh^3}{12}$$

then

$$I_o = \frac{6(12)^3}{12} = 864 \text{ in.}^4$$

What is the moment of inertia of the same rectangle about an axis through the centroid parallel to the 12-in. side?

Given:  $b = 12$  in. and  $h = 6$  in.

It should be observed that the base and altitude of the first example are interchanged in this example.

Then

$$I_o = \frac{12(6)^3}{12} = 216 \text{ in.}^4$$

**Parallel Axis Theorem.**—It is often desirable to obtain the moment of inertia of an area about an axis not passing through the centroid. This is accomplished by means of the parallel axis theorem, which is

$$I = I_o + Ad^2$$

$I_o$  represents the moment of inertia of the area about the axis through the centroid, and  $I$  is the moment of inertia of the area about any axis parallel to the centroidal axis.  $A$  is the area, and  $d$  is the perpendicular distance between the *parallel* axes.

Find the moment of inertia of a rectangle, 6 in.  $\times$  12 in., about an axis coinciding with the 6-in. base (Fig. 184).

Given:  $b = 6$  in. and  $h = 12$  in.

$$I_o = \frac{bh^3}{12} = \frac{6(12)^3}{12} = 864 \text{ in.}^4$$

$$I = I_o + Ad^2$$

$$\begin{aligned} I_x &= I_o + Ad^2 \\ &= 864 + 72(6)^2 \\ &= 864 + 2,592 = 3,456 \text{ in.}^4 \end{aligned}$$

Find the moment of inertia of an 8 in.  $\times$  9 in. triangle (Fig. 185) about an axis through the vertex, parallel to the 8-in. base.

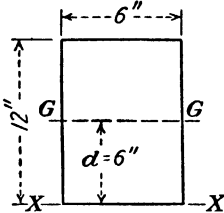

FIG. 184.

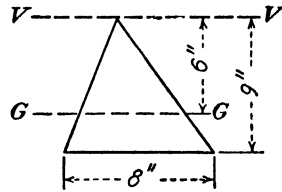

FIG. 185.

Given:  $b = 8$  in. and  $h = 9$  in.

$$I_o = \frac{bh^3}{36} = \frac{8(9)^3}{36} = 162 \text{ in.}^4$$

$$I = I_o + Ad^2$$

$$\begin{aligned} I_o &= I_o + Ad^2 \\ &= 162 + 36(6)^2 \\ I_o &= 162 + 1,296 = 1,458 \text{ in.}^4 \end{aligned}$$

In Fig. 186, the 6 in.  $\times$  6 in.  $\times$   $\frac{1}{2}$  in. angle section has been divided into two rectangles, as previously used in connection with the example of Fig. 167;  $\bar{y}$  has been calculated to be 1.68 in. What is the moment of inertia of the angle section about a horizontal axis 1-1 passing through the centroid of the section?

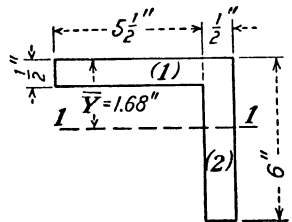

FIG. 186.

Considering rectangle (1) first,  $b = 5\frac{1}{2}$  in. and  $h = \frac{1}{2}$  in.

$$I_o = \frac{bh^3}{12} = \frac{5\frac{1}{2}(\frac{1}{2})^3}{12} = 0.0573 \text{ in.}^4$$

$$I = I_o + Ad^2$$

$$\begin{aligned} I_1 &= 0.0573 + 2.75(1.68 - 0.25)^2 \\ &= 0.0573 + 2.75(1.43)^2 \\ &= 0.0573 + 5.6234 = 5.6807 \text{ in.}^4 \end{aligned}$$

Considering rectangle (2),  $b = \frac{1}{2}$  in., and  $h = 6$  in.

$$I_o = \frac{bh^3}{12} = \frac{\frac{1}{2}(6)^3}{12} = 9 \text{ in.}^4$$

$$I = I_o + Ad^2$$

$$I_1 = 9 + 3(3 - 1.68)^2$$

$$= 9 + 3(1.32)^2$$

$$I_1 = 9 + 5.2272 = 14.2272 \text{ in.}^4$$

As the moment of inertia of each rectangle has been computed with reference to the *same axis*, the moments of inertia of the separate parts may be added. Hence,

$$\text{For rectangle (1)} \quad I_1 = 5.6807 \text{ in.}^4$$

$$\text{For rectangle (2)} \quad I_1 = 14.2272 \text{ in.}^4$$

$$\text{For the angle} \quad I_1 = 19.9079 \text{ in.}^4$$

$$= 19.91 \text{ in.}^4$$

By referring to the appendix for the inertias of various sections, the calculations of the moment of inertia of composite areas may be

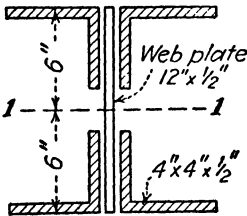

FIG. 187.

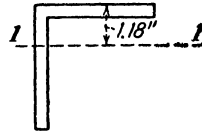

FIG. 188.

simplified. A built-up girder is shown in Fig. 187. It is made up of four angles 4 in.  $\times$  4 in.  $\times$   $\frac{1}{2}$  in. and a web plate 12 in.  $\times$   $\frac{1}{2}$  in. Let it be required to calculate the moment of inertia about a horizontal axis 1-1 passing through the centroid of the girder. The axis 1-1, which passes through the centroid of the composite area, is 6 in. from the top or bottom as determined by inspection, since the area is symmetrical about this axis.

Referring to the tables of elements of equal leg angle sections, one 4 in.  $\times$  4 in.  $\times$   $\frac{1}{2}$  in. angle has an area of 3.75 sq. in.,  $x$  or  $y = 1.18$  in., and

$$I_1 = 5.6 \text{ in.}^4 \text{ (see Fig. 188)}$$

$I_1 = 5.6 \text{ in.}^4$  is the value of  $I_o$  for use in the parallel axis theorem equation.

$$\begin{aligned}
 I &= I_o + Ad^2 \\
 I_1 &= I_o + Ad^2 \\
 I_1 &= 5.6 + 3.75(6 - 1.18)^2 \\
 &= 5.6 + 3.75(4.82)^2 \\
 &= 5.6 + 87.12 = 92.72 \text{ in.}^4 \text{ for each angle.}
 \end{aligned}$$

Then, for the four angles about the axis 1-1,

$$I_1 = 4(92.72) = 370.88 \text{ in.}^4$$

For the web plate

$$\begin{aligned}
 I_o &= \frac{bh^3}{12} = \frac{\frac{1}{2}(12)^3}{12} = 72 \text{ in.}^4 \\
 I_1 &= I_o + Ad^2 \\
 &= 72 + 6(0) = 72 \text{ in.}^4
 \end{aligned}$$

As the centroid of the web plate coincides with the centroid of the girder, the distance of transfer is zero and

$$I_1 = I_o = 72 \text{ in.}^4$$

Adding the inertias of the parts,

$$\begin{aligned}
 \text{Total } I_1 &= I_1 \text{ of four angles} + I_1 \text{ of the web plate} \\
 I_1 &= 370.88 + 72 = 442.88 \text{ in.}^4
 \end{aligned}$$

If a composite area contains a hole, the moment of inertia of the hole (as an area) about the required axis is obtained and then *subtracted* from the moment of inertia of the composite area without the hole.

**Radius of Gyration.**—The radius of gyration is of particular use in the design of long compression members or columns and is defined as the distance from the required axis at which all the area could be considered to be concentrated and the total moment of inertia would remain unchanged. As the moment of inertia is defined as the product of the area and the square of the distance from some axis, letting the distance be represented by  $r$ ,

$$I = Ar^2$$

from which

$$r^2 = \frac{I}{A}$$

and

$$r = \sqrt{\frac{I}{A}}$$

where  $r$  is the radius of gyration.

In the example of Fig. 184

$$I_x = 3,456 \text{ in.}^4$$

$$A = 72 \text{ in.}^2$$

then

$$\text{Radius of gyration } r = \sqrt{\frac{I}{A}} = \sqrt{\frac{3,456}{72}} = \sqrt{48} = 6.928 \text{ in.}$$

The moment of inertia of the girder shown in Fig. 187 was calculated to be 442.88 (in.)<sup>4</sup>. What is the radius of gyration about the 1-1 axis?

$$I_1 = 442.88 \text{ in.}^4$$

$$A = 4(3.75) + \frac{1}{2}12$$

$$= 15 + 6 = 21 \text{ in.}^2$$

$$r = \sqrt{\frac{I}{A}} = \sqrt{\frac{442.88}{21}} = \sqrt{21.09} = 4.59 \text{ in.}$$

**Polar Moment of Inertia.**—For rotating shafts, it is necessary to know the moment of inertia of the cross-sectional area about an axis which is perpendicular to the area and which passes through the centroid. Since the axis is perpendicular to the plane of the area, it is often called a *pole*, and the moment of inertia about this axis is called the *polar moment of inertia of the area*. The symbol of polar moment of inertia is  $J$ , and the value is determined by adding the moments of inertia about the 1-1

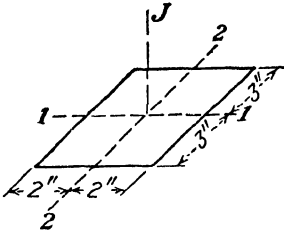

FIG. 189.

axis and the 2-2 axis; so

$$J = I_1 + I_2$$

Figure 189 is a sketch of a rectangle 4 in.  $\times$  6 in. Let it be required to calculate the polar moment of inertia about the polar axis  $J$ , which is perpendicular to the area and which passes through the centroid.

$$I_1 = I_o = \frac{bh^3}{12} = \frac{4(6)^3}{12} = 72 \text{ in.}^4$$

$$I_2 = I_o = \frac{bh^3}{12} = \frac{6(4)^3}{12} = 32 \text{ in.}^4$$

$$J = I_1 + I_2$$

$$= 72 + 32 = 104 \text{ in.}^4$$

Problems

126. What is the moment of inertia and radius of gyration of the rectangle shown in Fig. 190 about the 2-2 axis?

127. What is the moment of inertia of a circle, 4 in. in diameter, about any diameter?

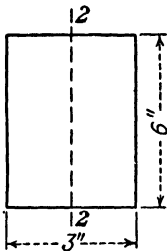

FIG. 190.

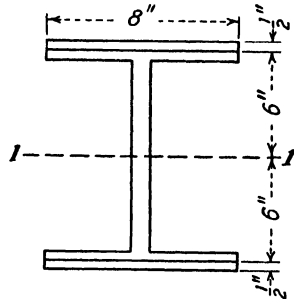

FIG. 191.

128. What is the polar moment of inertia of a circle, 4 in. in diameter, about the polar axis perpendicular to the center of gravity of the circle?

129. What is the moment of inertia (in terms of  $b$  and  $h$ ) of a triangle of base  $b$  and altitude  $h$  about an axis coinciding with the base?

130. Figure 191 shows a 12 in.  $\times$  8 in. wide flange (I beam) section that weighs 40 lb. per ft. Plates 8 in.  $\times$   $\frac{1}{2}$  in. are added at the top and bottom. Using the value of the moment of inertia of the I beam given in the appendix, what is the total moment of inertia of the beam and plates about the axis 1-1?

Problems 131, 132, and 133 refer to Fig. 192.

131. Solve  $y$  of the area. Calculate  $I_1$  of the area.

132. Calculate  $I_2$  of the area.

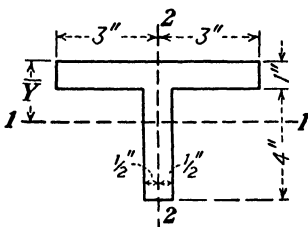

FIG. 192.

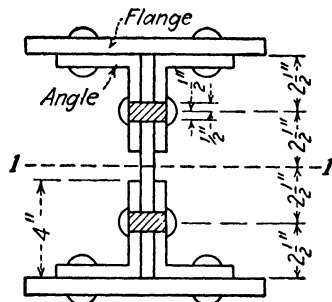

FIG. 193.

133. (a) Calculate the radius of gyration about the 1-1 axis.

(b) Calculate the radius of gyration about the 2-2 axis.

134. In Fig. 193, what is the moment of inertia about the 1-1 axis? Flange plates: 7 in.  $\times$   $\frac{1}{2}$  in.

Angles: 3 in.  $\times$  4 in.  $\times$   $\frac{1}{2}$  in. with 4-in. leg vertical.

Web plate: 10 in.  $\times$   $\frac{1}{2}$  in.

Two 1-in. rivet holes to be cut out. (Holes are the shaded rectangular areas  $1\frac{1}{2}$  in.  $\times$  1 in.)

**135.** Determine the moment of inertia of the area shown in Fig. 173 about a horizontal axis through the centroid.

**136.** What is the moment of inertia of the area shown in Fig. 175 about a horizontal axis through the centroid?

**137.** Solve the moment of inertia of the area of the ring about any diameter (Fig. 194).

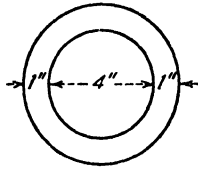

FIG. 194.

**138.** What is the polar moment of inertia of the area of the ring about the polar axis perpendicular to the center of the ring (Fig. 194)?

**139.** What is the polar moment of inertia (in terms of  $b^4$ ) of a square area of dimensions  $b$  about an axis perpendicular to the center of the square?

**140.** What is the radius of gyration of a circle (in terms of  $r$ ) of radius  $r$  about a diameter?

**141.** What is the moment of inertia of a 6-in. diameter circle about an axis tangent to the circle at any point?

## CHAPTER IX

### MOTION AND VELOCITY

An understanding of the laws governing the various types of motion of bodies is very important in engineering work. A machine is designed for the required strength, but, before that is done, an entirely different type of design is considered. In machine design, the motion of the machine is planned so that each part will be in the proper position to do what is required of it at the proper time. Thus we find that motion is very important in practical engineering work.

**Rectilinear Motion.**—Rectilinear motion is the motion of a body in a plane on a continuous straight path. A body falling freely in a vertical direction is an example of rectilinear motion.

**Velocity.**—Assuming that we know the distance that a point moves and the direction of its path, another item of information required for problems in motion is the time.

*The velocity of a moving point at any instant is the rate of motion in a specified direction, or it is the ratio of the space passed over in that direction to the time required for the motion.* Since magnitude and direction are expressed, velocity is treated as a vector quantity. In speaking of a train going 60 m.p.h. due north, the train has a velocity of 60 m.p.h. and could be represented by a vector. However, in speaking of a train going 60 m.p.h., only the magnitude of the velocity (which is called the *speed*) is expressed.

If a point on a moving body passes through equal space in a straight line in equal intervals of time, it has a uniform motion or *constant linear velocity*. If unequal spaces are passed through in equal periods of time, or if the direction of motion is changed, the *linear velocity is variable*. A point on a flywheel that is turning at a uniform rate has a uniform *angular velocity* as it turns through equal angles in equal periods of time. However, the linear direction of its motion is changing constantly, and therefore its linear velocity is variable. The linear velocity of a body falling freely through space is variable, since the body moves faster and faster as it descends in a vertical path. To specify a velocity, we must express distance, direction, and time. However, in many cases, in practice, the direction is considered obvious, and it may not be stated specifically.

**Acceleration is the Rate of Change of Velocity**, or it is the ratio of the change in velocity to the time necessary for this change. Since the change in velocity may be a change in magnitude or a change in direction, or both, the acceleration may be due to any one of these changes. Like velocity, acceleration is a vector quantity, which has magnitude and direction. *Linear acceleration* is the rate of change of linear velocity.

If a railway train starts from rest and increases its velocity in that direction by 1 ft. per sec. for each of the 60 sec. in a minute, its velocity at the end of the minute will be 60 ft. per sec. in that line. Since at the end of every second the train is traveling 1 ft. per sec. faster than it did the second before, its acceleration, or rate of gain in velocity, is 1 ft. per sec. in every second or, as it is often called, 1 ft. per sec. per sec., or 1 ft. per sec.<sup>2</sup>

#### RELATION BETWEEN VELOCITY, DISTANCE, AND CONSTANT ACCELERATION

The following notations and units will be used to express the various relations that exist between the velocity, time, distance, and constant acceleration:

$u$  = initial velocity, feet per second

$v$  = final velocity, feet per second

$s$  = distance, feet

$a$  = acceleration at a constant rate, feet per second per second, which is abbreviated ft. per sec.<sup>2</sup>

$t$  = time, seconds

$g$  = acceleration due to gravity = 32.2 ft. per sec.<sup>2</sup>

From the definitions of velocity and accelerations certain equations involving the above quantities have been set up:

$$\text{Average velocity} = \frac{u + v}{2}$$

$$v = u + at \tag{1}$$

$$s = \frac{u + v}{2} (t) \tag{2}$$

$$s = ut + \frac{1}{2}at^2 \tag{3}$$

$$s = \frac{v^2 - u^2}{2a} \tag{4}$$

A body which is falling freely under the pull of gravity is governed by the same equations except that the acceleration  $a$  is replaced by

the acceleration  $g$  of gravity, which is numerically equal to 32.2 ft. per sec.<sup>2</sup>

Acceleration for increasing velocities is usually considered positive, and that for decreasing velocities is usually considered negative.

*Examples.*—A man, walking at a constant rate goes 500 ft. in 2 min. What is his rate (velocity) in miles per hour?

Given:  $s = 500$ ;  $t = 2$  min. = 120 sec.

Since

$$\frac{u + v}{2} = \text{average velocity}$$

Using Eq. (2)

$$\begin{aligned} s &= \left( \frac{u + v}{2} \right) t \\ 500 &= \left( \frac{u + v}{2} \right) 120 \\ \frac{u + v}{2} &= \frac{500}{120} = 500 = 4.17 \text{ ft. per sec.} \end{aligned}$$

The man's rate is then 4.17 ft. per sec. To convert feet per second to miles per hour, multiply by the number of seconds in an hour, and divide by the number of feet in a mile.

Then

$$\frac{4.17 \times 3,600}{5,280} = 2.84 \text{ m.p.h.}$$

A body starts from rest with an acceleration of 5 ft. per sec.<sup>2</sup> What is its velocity at the end of 10 sec., and how far will it go in that time?

Given:  $a = 5$  ft. per sec.<sup>2</sup>;  $t = 10$  sec.;  $u = 0$ .

By Eq. (1)

$$\begin{aligned} v &= u + at \\ v &= 0 + 5(10) = 50 \text{ ft. per sec.} \end{aligned}$$

By Eq. (3)

$$\begin{aligned} s &= ut + \frac{1}{2}at^2 \\ s &= 0 + \frac{1}{2}(5)(10)^2 \\ &= 250 \text{ ft.} \end{aligned}$$

*Note:* Sixty miles per hour is equivalent to 88 ft. per sec. Miles per hour can be converted to feet per second in a direct ratio, as can feet per second be converted to miles per hour.

Thus

$$\begin{aligned} 10 \text{ m.p.h.} &= x \text{ ft. per sec.} \\ \frac{10 \text{ m.p.h.}}{60 \text{ m.p.h.}} &= \frac{x \text{ ft. per sec.}}{88 \text{ ft. per sec.}} \\ \therefore x &= \frac{10}{60}(88) = 14.67 \text{ ft. per sec.} \end{aligned}$$

or

$$\begin{aligned} 44 \text{ ft. per sec.} &= x \text{ m.p.h.} \\ \frac{x \text{ m.p.h.}}{60 \text{ m.p.h.}} &= \frac{44 \text{ ft. per sec.}}{88 \text{ ft. per sec.}} \\ \therefore x &= \frac{44}{88}(60) = 30 \text{ m.p.h.} \end{aligned}$$

A body falls 3 ft. from a table to the floor. If there is no initial velocity, what time is required, and with what velocity does the body hit the floor?

$$\text{Given: } s = 3 \text{ ft.; } a = g = 32.2 \text{ ft. per sec.}^2$$

By Eq. (3)

$$\begin{aligned} s &= ut + \frac{1}{2}at^2 = ut + \frac{1}{2}gt^2 \\ 3 &= 0 + \frac{1}{2}(32.2)t^2 \\ t^2 &= \frac{3}{16.1} = 0.1863 \\ t &= \sqrt{0.1863} = 0.432 \text{ sec.} \end{aligned}$$

By Eq. (4)

$$\begin{aligned} s &= \frac{v^2 - u^2}{2a} = \frac{v^2 - u^2}{2g} \\ 3 &= \frac{v^2 - 0}{2(32.2)} \\ \therefore v^2 &= 3 \times 2 \times 32.2 \\ &= 193.2 \\ v &= 13.9 \text{ ft. per sec.} \end{aligned}$$

### Problems

**142.** An automobile running at 40 m.p.h. is stopped in a distance of 196 ft. What is the negative acceleration? What time is required?

**143.** A body is thrown vertically upward with a velocity of 50 ft. per sec. How high will the body go? What time elapses while the body is in the air? Neglect air resistance.

**144.** A train increases its velocity from 12 m.p.h. to 30 m.p.h. at an acceleration of 0.12 ft. per sec.<sup>2</sup> What time is required? What distance in miles is required?

**145.** What acceleration is necessary for a car to attain a velocity of 20 m.p.h. in 10 sec.?

**146.** A man runs 100 yd. in 10 sec. What is his average velocity?

**147.** A projectile is shot vertically upward and reaches a height of 644 ft. What was its initial vertical velocity? What is the velocity halfway up? What time is required for the projectile to go up?

**148.** If an elevator starts from rest, what acceleration must it have to attain a maximum velocity of 800 ft. per min. in a distance of 12 ft.?

**149.** A train starts from a station and attains a velocity of 40 m.p.h. in 2 min. It then slows down until it stops in 3 min. What is the total distance?

**150.** A body has an initial velocity of 10 ft. per sec. and an acceleration of 4 ft. per sec. in the same direction. What is the velocity at the end of 4 sec.? at the end of 5 sec.? What distance is traversed during the fifth second? **72', 100**

**151.** From a mine cage, which is descending at the rate of 20 ft. per sec., a body rolls off and falls 200 ft. to the bottom of the pit. With what velocity does the body strike the bottom? What time is required for the body to reach the bottom?

**152.** Solve problem 149 when the cage is going upward at the rate of 20 ft. per sec.

## CHAPTER X

### FORCE AND ACCELERATION

In the preceding discussion of motion, pure motion only was considered, in which it was not necessary to consider the mass of the body. Now it is necessary to consider the mass of the moving body, where mass is defined as the quantity of matter in a body.

Newton's second law of motion states that when a particle is acted upon by a force, the particle is accelerated in the direction of the force, and the rate of the acceleration is directly proportional to the force and is inversely proportional to the mass. We know that the weight

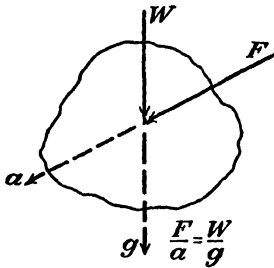

FIG. 195.

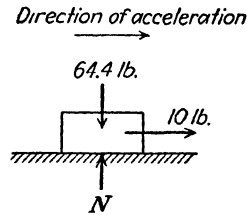

FIG. 196.

$W$  (Fig. 195) of any body gives to that body an acceleration downward of  $g$  (32.2 ft. per sec.<sup>2</sup>). Now if any other force  $F$  acts on the same body and gives it an acceleration  $a$ , then since both forces  $W$  and  $F$  acted on the same mass

$$\frac{F}{a} = \frac{W}{g} \quad \text{or} \quad F = \frac{W}{g} a \quad (5)$$

*Example.*—A body weighing 64.4 lb. is resting on a smooth horizontal plane. A horizontal pull of 10 lb. is applied to the body. What is its rate of acceleration? How far will it go in 5 sec. if the block starts from rest (Fig. 196)?

Given:  $W = 64.4 \text{ lb.}; F = 10 \text{ lb.}; t = 5 \text{ sec.}; u = 0.$

From Eq. (5)

$$F = \frac{W}{g} a$$

$$10 = \frac{64.4}{32.2} a$$

$$a = \frac{10(32.2)}{64.4} = 5 \text{ ft. per sec.}^2$$

By Eq. (3), page 100,

$$s = ut + \frac{1}{2}at^2$$

$$s = 0 + \frac{1}{2}(5)(5)^2$$

$$= 62.5 \text{ ft.}$$

*Example.*—A body weighing 100 lb. is resting on a plane inclined at  $10^\circ$  to the horizontal. Neglecting friction, what is the acceleration of the body when a pull  $P$  of 20 lb. is applied parallel to the incline (Fig. 197)?

Given:  $W = 100 \text{ lb.}$ , and  
 $P = 20 \text{ lb.}$

Resolving the weight into its components parallel and perpendicular, respectively, to the incline,

$$W \sin 10^\circ = 100(0.1737)$$

$$= 17.37 \text{ lb.}$$

$$W \cos 10^\circ = 100(0.9848)$$

$$= 98.48 \text{ lb.}$$

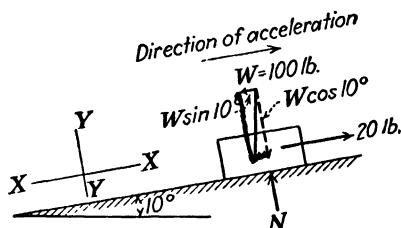

FIG. 197.

Then the equation for determining the amount of the unbalanced force *parallel* to the inclined plane is

$$F = P - W \sin 10^\circ$$

$$= 20 - 17.37 = 2.63 \text{ lb.}$$

*Note:* This is an  $H$  equation where the  $x$ - $x$  axis is parallel to the plane on which the body is resting. As the forces are not in equilibrium, since the body will move, the equation is not equal to zero.

From Eq. (5), page 104,

$$F = \frac{W}{g} a$$

$$2.63 = \frac{100}{32.2} a$$

$$a = \frac{2.63(32.2)}{100} = \frac{84.686}{100} = 0.847 \text{ ft. per sec.}^2$$

*Example.*—Two bodies weighing 30 and 10 lb., respectively, are hung on a rope that passes over a frictionless pulley. The bodies are then released, and the system is allowed to move under the influence of gravity. What is the rate of acceleration of the system (Fig. 198)?

As the bodies are connected, they must move with the same rate of acceleration, and the total weight to be accelerated is the sum of the

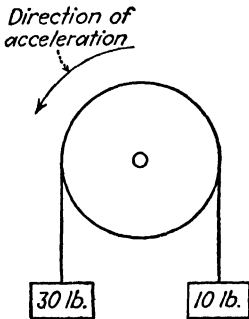

FIG. 198.

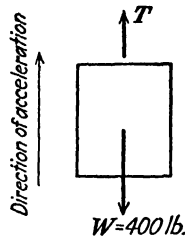

FIG. 199.

two weights,  $30 + 10 = 40$  lb. The rate of acceleration is dependent on the unbalanced force, which is  $30 - 10 = 20$  lb. Hence, by Eq. (5),

$$F = \frac{W}{g} a$$

$$20 = \frac{40}{32.2} a$$

Then

$$a = \frac{20 \times 32.2}{40} = 16.1 \text{ ft. per sec.}^2$$

It is always advisable, before attempting the solution of the problems, to make a free body sketch showing the forces that are applied to the body and the direction of the acceleration.

*Example.*—A hoist when loaded weighs 400 lb. What pull must be applied to the cable for the hoist to be accelerated upward at the rate of 12 ft. per sec.<sup>2</sup>? Letting  $T$  in Fig. 199 represent the pull in the cable, we have given

$$W = 400 \text{ lb.}; \quad a = 12 \text{ ft. per sec.}^2$$

By a  $V$  equation, it will be seen that the unbalanced force  $F$  is

$$F = T - 400$$

By Eq. (5)

$$\begin{aligned}
 F &= \frac{W}{g} a \\
 T - 400 &= \frac{W}{g} a \\
 T &= 400 + \frac{400}{32.2} 12 \\
 &= 400 + 149.1 \\
 &= 549.1 \text{ lb.}
 \end{aligned}$$

*Example.*—Using the same hoist as in the preceding example, what pull must be applied to the cable if the hoist is accelerated downward at the rate of 12 ft. per sec.<sup>2</sup>?

When  $T$  is less than the weight, the hoist will move downward owing to the unbalanced force, or

$$400 - T = F$$

By Eq. (5)

$$\begin{aligned}
 F &= \frac{W}{g} a \\
 400 - T &= \frac{W}{g} a = \frac{400}{32.2} 12 \\
 T &= 400 - \frac{400}{32.2} 12 \\
 &= 400 - 149.1 \\
 &= 250.9 \text{ lb.}
 \end{aligned}$$

**Problems**

153. A 100-lb. weight is pulled along a frictionless horizontal plane by a force of 20 lb. What is the rate of acceleration? *6.4/sec<sup>2</sup>*

154. How far does the weight in problem 153 move in 4 sec. if it starts from rest? What is its velocity at the end of 4 sec.? *51.60 ft.*

155. A 50-lb. weight is pulled up a 20° frictionless incline by a force of 25 lb. acting parallel to the incline. What is the rate of acceleration? How long will it take for the body to move 10 ft.? *1.27 sec.*

156. A 50-lb. cake of ice slides down a chute inclined at 30° to the horizontal. Assuming the chute to be frictionless, what time is required if the chute is 20 ft. long?

157. An elevator, together with the passengers, weighs 4,000 lb. If the elevator is to be accelerated at the rate of 10 ft. per sec.<sup>2</sup> going upward, what pull must be applied to the cable? *5250 lb*

158. If the elevator in problem 157 is limited to a downward acceleration of 20 ft. per sec.<sup>2</sup>, what retarding pull must be applied to the cable? *2750 lb*

159. If the coefficient of friction between the plane and the weight in problem 153 is 0.1, what is the rate of acceleration? *3.2/sec<sup>2</sup>*

160. In problem 155, the coefficient of friction between the incline and the weight is 0.1. What is the rate of acceleration?

161. Find the time required, in problem 156, if the coefficient of friction of the ice on the chute is 0.05.

162. In Fig. 200, what is the acceleration of the system? The pulley is frictionless and the plane on which block *A* rests is smooth.

163. What is the acceleration of the system in Fig. 200 if the coefficient of friction between the plane and block *A* = 0.2? What is the acceleration if the coefficient of friction is 0.5?  $6.4' / \text{sec}^2$ ,  $-3.2' / \text{sec}^2$

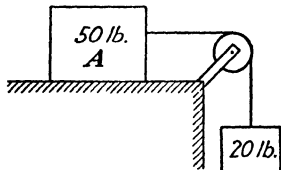

FIG. 200.

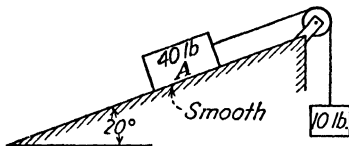

FIG. 201.

164. In Fig. 201, in which direction does the system move? What is its rate of acceleration? What is the velocity of the system at the end of 10 sec.?

165. An elevator car with its passenger load weighs 1,610 lb. Find the tension in its cable when it is traveling upward and is (a) increasing speed at the rate of 16 ft. per sec.<sup>2</sup> and (b) decreasing speed at the rate of 16 ft. per sec.<sup>2</sup>

166. Find the tension in the cable of problem 165 when the car is traveling downward and is (a) increasing speed at the rate of 16 ft. per sec.<sup>2</sup> and (b) decreasing speed at the rate of 16 ft. per sec.<sup>2</sup>

167. Two blocks, *A* and *B*, each weigh 1,300 lb. and rest on an incline as shown in Fig. 202. The coefficient of friction between block *A* and the incline is 0.1, and between block *B* and the incline is 0.2. The blocks are connected by a weightless cord. What is the acceleration of the system?  $330 + 260$   $640' / \text{sec}^2$   
 $A + B$

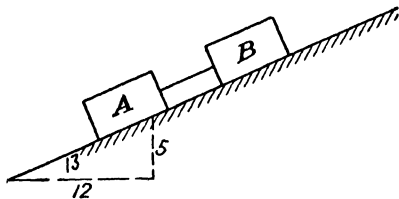

FIG. 202.

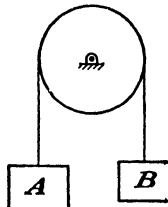

FIG. 203.

168. In Fig. 203, blocks *A* and *B* are hung on a weightless cord that passes over a weightless, frictionless pulley. Weight *B* weighs 20 lb. Starting from rest, weight *A* moves downward 10 ft. in 4 sec. What is the weight *A*?

169. Solve problem 168 if weight *A* moves upward.



The vertical component  $V$  becomes the initial vertical velocity, which changes continuously under the influence of gravity.

By Eq. (1), page 100,

$$v = u + gt$$

at the maximum height

$$v = 0$$

because the vertical component of the velocity at the top of the path is zero; that is, the projectile is moving in a horizontal direction at that instant. In the equation

$$v = u + gt$$

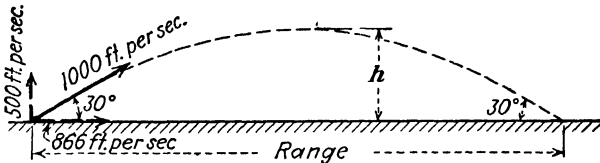

FIG. 205.

$g = -32.2$  ft. per sec.<sup>2</sup>, as the velocity is decreasing.

Then

$$0 = 500 - 32.2t$$

$$t = \frac{500}{32.2} = 15.53 \text{ sec. (for projectile to go up)}$$

$$\text{Total time of flight} = 2(15.53) = 31.06 \text{ sec.}$$

since the projectile requires as much time to come down as to go up.

By Eq. (4), page 100,

$$s = \frac{v^2 - u^2}{2g}$$

$$s = \frac{0 - (500)^2}{2(-32.2)} = \frac{-250,000}{-64.4}$$

$$s = 3,882 \text{ ft. maximum height}$$

As the horizontal component of the velocity is constant at 866 ft. per sec., for 31.06 sec., the projectile will travel horizontally a distance equal to the product of the total time and the horizontal velocity or

$$\begin{aligned} s &= \left( \frac{u + v}{2} \right) t & (2) \\ &= \left( \frac{866 + 866}{2} \right) 31.06 \\ &= 26,898 \text{ ft. total range} \end{aligned}$$

*Example.*—In the preceding example, what is the velocity of the projectile and what is its direction when it is 2,000 ft. above the earth (plane from which the projectile started)? In Fig. 206, it will be seen

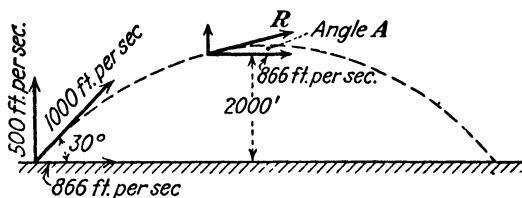

FIG. 206.

that we must determine the vertical component of the resultant velocity  $R$  at a height of 2,000 ft.

By Eq. (4)

$$s = \frac{v^2 - u^2}{2g}$$

$$2000 = \frac{v^2 - (500)^2}{2(-32.2)}$$

$$\begin{aligned} v^2 &= 2,000(2)(-32.2) + (500)^2 \\ &= -128,800 + 250,000 \\ &= 121,200 \end{aligned}$$

$$v = 348.8 \text{ ft. per sec.}$$

$$\begin{aligned} R &= \sqrt{V^2 + H^2} = \sqrt{(348.8)^2 + (866)^2} \\ &= \sqrt{121,200 + 750,000} = \sqrt{871,200} = 933.4 \text{ ft. per sec.} \end{aligned}$$

$$\tan A = \frac{348.8}{866} = 0.4028$$

then

$$a = 21^\circ 56'$$

*Example.*—What is the velocity and direction of the projectile in the preceding examples 20 sec. after it starts (Fig. 207)?

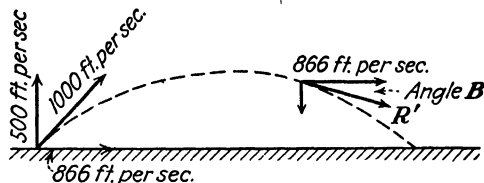

FIG. 207.

It is not necessary that we know whether the projectile is still going upward, or if it is coming down, at the end of the 20-sec. period

of time. If we set up Eq. (1) for solving the vertical component of the velocity, knowing that the projectile is being decelerated immediately after it starts on its flight, then

$$\begin{aligned} v &= u + gt \\ v &= 500 - (32.2)(20) \\ &= 500 - 644 = -144 \text{ ft. per sec.} \end{aligned}$$

The negative sign shows that the projectile has reached the top of its path and has started downward in the 20 sec. of elapsed time.

Then

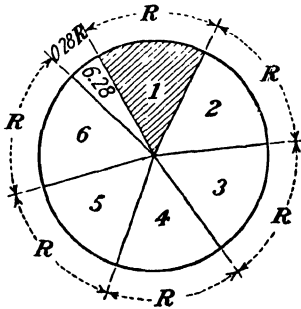

FIG. 208.

$$\begin{aligned} R' &= \sqrt{V^2 + H^2} \\ &= \sqrt{(144)^2 + (866)^2} \\ &= \sqrt{20,736 + 750,000} \\ &= \sqrt{770,736} \\ &= 877.9 \text{ ft. per sec.} \\ \tan B &= \frac{144}{866} = 0.1663 \quad \text{and} \\ B &= 9^\circ 27' \end{aligned}$$

**Velocity as Applied to Rotating Bodies.**—Consider the disk of Fig. 208 as rotating about its center *O*. Any point *A* on the circumference of the disk will go through a distance equal to the circumference for each revolution. Now, since the circumference of any circle can be found by multiplying the diameter or twice the radius by the value 3.1416, the distance that the point *A* goes through in one revolution is  $D \times 3.1416$ , in which  $D$  is the diameter of the disk which carries the point *A*. Suppose now that the disk makes several revolutions in a minute of time. To find the distance that the point *A* moves through, we must multiply the distance it moves through for each revolution, or the circumference of the circle, by the number of revolutions it makes per minute. If the number of revolutions per minute are represented by the letter  $N$  and the value 3.1416 by the Greek letter  $\pi$ , in 1 min. the point *A* will move through a distance equal to  $\pi \times D \times N$ , or, as it is commonly written,

$$\text{Linear velocity} = \pi DN.$$

**Angular Velocity.**—In most cases of circular motion, it is found more desirable to measure the velocity of the moving points in angular measurement than in linear measurement. Referring again to Fig. 208, if along the circumference of the circle an arc  $R$  that is equal to

the radius is laid off and the ends are connected to the center of the circle, there is then obtained, as in the shaded area, the unit of angular measurement. This unit is called the *radian* and is defined as the angle subtended by an arc of a circle where the arc is equal in length to the radius.

Since in all circles the circumference is equal to  $\pi D$ , the circumference divided by the radius will give

$$\frac{\pi D}{R} = \frac{2\pi R}{R} = 2\pi$$

Thus, as shown by the radial lines, in Fig. 208, there must be  $2\pi$ , or 6.28 radians in any circle. The angular velocity of a point on a rotating body will be the number of these unit angles, or radians, that the moving point passes through in a unit of time.

Again consider the point  $A$  in Fig. 208, and suppose that the disk makes 1 revolution at constant velocity. Then  $A$  passes through  $2\pi$ , or 6.28 unit angles or radians. If the time required for that one revolution was 1 min., the angular velocity of  $A$  would be  $2\pi$  radians per min. If, however, instead of making 1 revolution per minute, the body makes several, or say  $N$ , revolutions per minute, the angular velocity is  $N$  times  $2\pi$ , or

$$\text{Angular velocity} = 2\pi N$$

It will be well here to make a brief comparison between the angular velocity and the linear velocity of any point such as  $A$ .

$$\text{Angular velocity} = 2\pi N$$

$$\text{Linear velocity} = \pi DN = 2\pi RN$$

These two statements are the same, except that the term  $R$  appears in the statement for linear velocity. This shows that in the case of linear velocity, the velocity of the point depends on the radius as well as on the number of revolutions. But, since the term  $R$  does not appear in the statement for angular velocity, it is evident that the angular velocity depends only on the number of revolutions and is independent of the size of the rotating body. In other words, the angular velocity of all points in a rotating body will be the same regardless of their distances from the center. A further study of the two statements will bring out the important relation that angular velocity equals linear velocity divided by the radius. That is,

$$\text{Angular velocity} = \frac{\text{L.V.}}{R} = \frac{2\pi RN}{R} = 2\pi N$$

**Accelerated Rotation.**—As in the case of uniformly accelerated motion in a straight line, rotating bodies are governed by the same general equations. The principal difference will be in the system of units. Thus, using the same symbols,

$u$  = initial velocity, radians per second

$v$  = final velocity, radians per second

$s$  = displacement, radians

$a$  = acceleration at a constant rate, radians per second per second  
(radians per second<sup>2</sup>).

$t$  = time, seconds

$$\text{Average velocity} = \frac{u + v}{2}$$

$$v = u + at \tag{1}$$

$$s = \left( \frac{u + v}{2} \right) t \tag{2}$$

$$s = ut + \frac{1}{2}at^2 \tag{3}$$

$$s = \frac{v^2 - u^2}{2a} \tag{4}$$

*Example.*—A flywheel, retarded at a constant rate, comes to rest in 8 min. after making 3,000 revolutions. What is its rate of negative acceleration, and what was its initial velocity?

Given:  $t = 8 \text{ min.} = 480 \text{ sec.}$

$s = 3,000 \text{ rev.} = 3,000 \times 2\pi = 6,000\pi \text{ rad.}$

$v = 0$

By Eq. (2),

$$s = \left( \frac{u + v}{2} \right) t$$

$$6,000\pi = \left( \frac{u + 0}{2} \right) 480$$

$$\frac{6,000\pi}{480} = \frac{u}{2}$$

$$\therefore u = \frac{12,000\pi}{480}$$

$$u = 25\pi = 78.5 \text{ rad. per sec.}$$

By Eq. (1),

$$v = u + at$$

$$0 = 78.5 - a(480)$$

$$a = \frac{78.5}{480} = 0.1635 \text{ rad. per sec.}^2$$

*Example.*—The rim of a 33-in. diameter wheel has a velocity of 60 m.p.h. The wheel comes to rest after the rim has traveled a tangential distance of 440 ft. What is the angular negative acceleration?

Given: Diameter = 33 in. = 2.75 ft.

Linear velocity  $u = 60$  m.p.h. = 88 ft. per sec.

Angular velocity  $u = \frac{88}{R} = \frac{88}{\frac{2.75}{2}} = 63.8$  rad. per sec.

Displacement  $s = 440$  ft. =  $\frac{440}{\pi D} = \frac{440}{\pi(2.75)}$   
 $= 50.9$  rev. =  $50.9(2\pi)$  rad.  
 $= 320$  rad.

Final velocity  $v = 0$

By Eq. (4), page 114,

$$s = \frac{v^2 - u^2}{2a}$$

$$320 = \frac{0 - (63.8)^2}{2a}$$

$$a = \frac{-(63.8)^2}{2(320)} = -6.36 \text{ rad. per sec.}^2$$

### Problems

**170.** A projectile is fired from a gun, elevated at an angle of  $45^\circ$ , with a velocity of 1,000 ft. per sec. What is the range of the gun on level ground?

**171.** In problem 170, what is the vertical component of the velocity of the projectile 10 sec. after being fired?

**172.** A stone is thrown horizontally off a cliff 200 ft. high with a velocity of 20 ft. per sec. What time is required for the stone to strike the ground? How far from the foot of the vertical cliff will the stone hit the ground?

**173.** A projectile fired at an angle of elevation has a horizontal range of 10,000 ft. If the maximum height reached is 1,610 ft., what was the angle of elevation of the gun? What was the muzzle velocity of the projectile?

**174.** A projectile has a velocity of 2,000 ft. per sec. when fired at an angle of elevation of  $30^\circ$ . What is the velocity and direction of the projectile at the top of its path? What is its velocity and direction 2 sec. after it starts on its downward path? What is its velocity and direction when it strikes the level ground from which it was fired?

**175.** An airplane is traveling horizontally at 240 m.p.h. when its altitude above the ground is 8,000 ft. How far back of a target on the ground must a bomb be released in order to hit the target? What time is required from the instant of release? How far has the plane traveled from the point of release until the bomb strikes the ground?

**176.** A train is running over a trestle 32.2 ft. high with a speed of 40 ft. per sec. A lump of coal is thrown horizontally at right angles to the direction of the

train at a velocity of 30 ft. per sec. How far from the point of throwing does the coal hit the ground? (*Note:* The component of the velocity of the coal parallel to the ground will be the resultant of the velocity of the train and the initial velocity of the coal.)

**177.** In problem 176, what is the velocity of the coal 1 sec. after it is thrown?

**178.** A pulley 18 in. in diameter makes 300 r.p.m. What is the linear velocity of a point on the rim of the pulley? of a point 6 in. from the center?

**179.** What is the angular velocity of each of the points on the pulley in problem 178?

**180.** A pulley 12 in. in diameter has a linear velocity at the rim equal to 540 ft. per min. Calculate the r.p.m. of the pulley.

**181.** The angular velocity of a wheel 12 in. in diameter is 26 rad. per sec. Calculate the r.p.m. of the pulley and the linear velocity of a point 3 in. from its center.

**182.** A shaft 6 in. in diameter has a surface linear velocity of 180 ft. per minute. What is its angular velocity?

**183.** A flywheel is brought from rest to a speed of 60 r.p.m. in  $\frac{1}{2}$  min. What is the angular acceleration? What is the angular velocity at the end of 15 sec.?

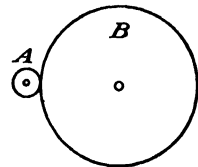

FIG. 209.

**184.** A flywheel revolving at 200 r.p.m. slows down at a constant rate of 2 rad. per sec.<sup>2</sup> How many seconds are required for it to stop? How many revolutions does it make?

**185.** A wheel, starting from rest, has an acceleration of 1 rad. per sec.<sup>2</sup> Calculate the angular velocity and revolutions at the end of 2 min.

**186.** A wheel has its velocity increased from 120 to 240 r.p.m. in 20 sec. What is its rate of acceleration? How many revolutions are required?

**187.** In Fig. 209, the smaller wheel *A* is 3 in. in diameter and is rotating at 30 r.p.m. The larger wheel *B* is 24 in. in diameter. What is the angular velocity of each wheel? What is the linear velocity of a point on the rim of each wheel?

**188.** In problem 187, if the wheels come to rest in 10 sec., what is the angular acceleration of each. What is the number of revolutions required by each wheel while they are coming to rest?

$$500 = 2v^2$$

$$v^2 = 250$$

$$v = 15.81 \text{ ft. per sec.}$$

Checking,

$$\text{Unbalanced force} = 10 \text{ lb. (see above)}$$

By Eq. (5)

$$F = \frac{W}{g} a$$

$$10 = \frac{128.8}{32.2} a$$

$$a = \frac{10(32.2)}{128.8} = 2.5 \text{ ft. per sec.}^2$$

By Eq. (4)

$$s = \frac{v^2 - u^2}{2a}$$

$$50 = \frac{v^2 - 0}{2(2.5)}$$

$$v^2 = 50(2)(2.5)$$

$$= 250$$

$$v = 15.81 \text{ ft. per sec. (as above)}$$

### Problems

**189.** A man lifts a weight of 50 lb. from the floor to a bench 30 in. high. How much work does he do? Does the amount of work depend on the path of the weight? on the time required to lift it?

**190.** A man pushes horizontally on a die weighing 40 lb. resting on top of a workbench; the coefficient of kinetic friction is 0.4 for the surfaces in contact. If he moves the die 10 ft. in 30 sec., how much work has he done? What horsepower did he exert? What is the average velocity of the die?

**191.** A train of 40 cars, each weighing 40 tons, is pulled up a 1% grade by a locomotive for a distance of 1 mile. How much work is done if the frictional resistances are 6 lb. per ton of the weight of the train? When the train is moving with a velocity of 15 m.p.h., what horsepower does the locomotive exert? *Suggestion:* the locomotive drawbar pull must overcome the frictional resistances and the component of the weight parallel to the plane on which the train moves. Use the sine of the angle as 0.01 and the cosine as 1.0.

**192.** A water tower that will hold 7,480 gal. of water is to be filled by pumping water a height of 200 ft. How much work is done and what horsepower is required if it requires 40 min. to fill the tower?

**193.** A crane can lift a 10-ton weight 16 ft. in 20 sec. What horsepower is required?

**194.** A block weighing 80 lb. is moved on a horizontal floor by a pull at an angle of 25° above the floor. The coefficient of kinetic friction is 0.4. How much work is done if the block moves a horizontal distance of 46 ft.?

**195.** A car weighing 40 tons is moving at 30 m p.h. up a  $10^\circ$  incline. The total frictional resistance parallel to the incline is 1,600 lb. What horsepower is required?

**196.** A body weighing 50 lb. falls 60 ft. from the top of a vertical cliff. What is the potential energy at the top? What is the kinetic energy at the top? What is the potential energy at the bottom? What is the kinetic energy at the bottom?

**197.** A body that weighs 161 lb. is moving at 30 m.p.h. What is its kinetic energy?

**198.** If the body in problem 197 is moving on a horizontal floor, what horizontal force is required to stop it in a distance of 20 ft.?

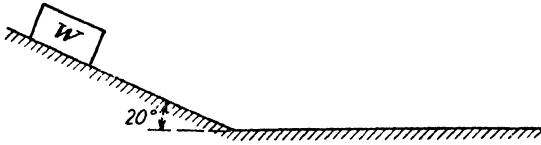

FIG. 214.

**199.** A body weighing 128.8 lb. is pulled 50 ft. along a horizontal plane, for which the coefficient of kinetic friction is 0.1, by a horizontal force of 20.88 lb. If the force then ceases to act, how much farther will the body slide before coming to rest?

**200.** If the body in problem 197 has its velocity increased to 60 m.p.h., what is the gain in kinetic energy?

**201.** A body weighing 80 lb. is pushed up a  $20^\circ$  incline by a force of 50 lb. parallel to the incline. The coefficient of kinetic friction is 0.15. If the body starts from rest, how far up the incline must it go until its velocity is 40 ft. per sec.? If this body starts up the incline with an initial velocity of 10 ft. per sec., how far will it go until its velocity is 40 ft. per sec.?

**202.** In problem 201, if the body starts up the incline at 10 ft. per sec., what is its velocity 40 ft. up the incline?

**203.** A body weighing 22 lb. can be kept in motion on a horizontal plane by a force of 7.5 lb. parallel to the plane. How much work is done if the body moves one-quarter of a mile? What horsepower is required if the body moves this distance in  $\frac{1}{2}$  min.?

**204.** A body,  $W = 161$  lb., starts from rest down a  $20^\circ$  incline, as shown in Fig. 214. The coefficient of friction is 0.1. The incline is 100 ft. long. (a) How much work is done while the body slides down the incline? (b) What is the kinetic energy at the bottom of the incline? (c) Assuming no loss in energy due to the change in direction at the bottom of the incline, how far will the body slide on the horizontal plane before it stops?

## APPENDIX

### AXIS DESIGNATIONS

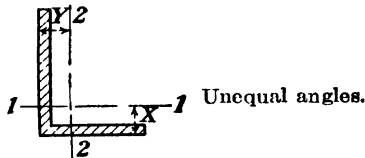
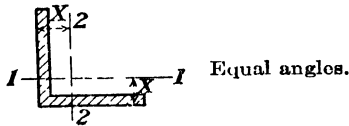
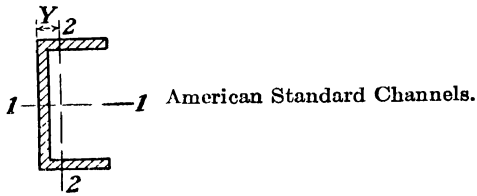
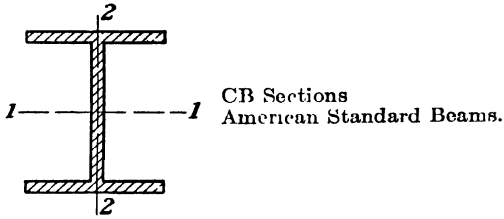

The following tables are printed by permission of the Carnegie-Illinois Steel Corporation. The tables of CB Sections, American Standard Beam Sections, and Elements of Sections are not copied in their entirety owing to lack of space, and for student use partial tables are sufficient.

CB SECTIONS  
Elements of Sections

Section under and nominal size	Depth of section, in.	Weight per foot, lb.	Area of section, in. <sup>2</sup>	Flange		Web thickness, in.	Axis 1-1			Axis 2-2		
				Width, in.	Thickness, in.		I, in. <sup>4</sup>	S, in. <sup>3</sup>	r, in.	I, in. <sup>4</sup>	S, in. <sup>3</sup>	r, in.
CB 362 36 × 16½	36 72	300	88 17	16 055	1 680	945	20,290 2	1105 1	15 17	1225 2	147 1	3 73
	36 24	260	76 56	16 555	1 440	845	17,233 8	951 1	15 00	1020 6	123 3	3 65
	36 00	240	70 60	16 500	1 320	790	15,724 0	873 6	14 92	920 1	111 6	3 61
CB 361 36 × 12	36 48	194	57 11	12 117	1 260	770	12,103 4	663 6	14 56	355 4	58 7	2 49
	36 16	170	49 98	12 027	1 100	680	10,470 0	579 1	14 47	300 6	50 0	2 45
	35 84	150	41 16	11 972	940	625	9012 1	502 9	14 29	250 4	41 8	2 38
CB 332 33 × 15½	33 50	240	70 52	15 865	1 400	830	13,585 1	811 1	13 88	874 3	110 2	3 52
	33 12	210	61 78	15 783	1 210	748	11,664 5	704 4	13 74	735 6	93 2	3 45
CB 331 33 × 11½	33 50	152	44 71	11 565	1 055	635	8147 6	486 4	13 50	256 1	44 3	2 39
	33 15	132	38 84	11 510	880	580	6856 8	413 7	13 29	207 8	36 1	2 31
CB 302 30 × 15	30 38	210	61 78	15 105	1 315	775	9872 4	640 9	12 64	707 9	93 7	3 38
	30 12	190	55 90	15 040	1 185	710	8825 9	586 1	12 57	624 6	83 1	3 34
	29 88	172	50 65	14 985	1 065	655	7891 5	528 2	12 48	560 1	73 4	3 30
CB 301 30 × 10½	30 30	132	38 83	10 551	1 000	615	5753 1	379 7	12 17	185 0	35 1	2 18
	30 00	116	34 13	10 500	850	564	4919 1	327 9	12 00	153 2	29 2	2 12
CB 272 27 × 14	27 31	177	52 10	14 090	1 190	725	6728 6	492 8	11 36	518 9	73 7	3 16
	27 00	154	45 30	14 000	1 035	635	5775 8	427 8	11 29	437 6	62 5	3 11
CB 271 27 × 10	27 28	114	33 53	10 070	932	570	4080 5	299 2	11 03	149 6	29 7	2 11
	27 00	98	28 82	10 000	792	500	3446 5	255 3	10 94	122 9	24 6	2 07
CB 243 24 × 14	24 72	160	47 04	14 091	1 135	656	5110 3	413 5	10 42	492 6	69 9	3 23
	24 41	140	41 16	14 029	980	594	4376 1	358 6	10 31	414 5	59 1	3 17
CB 242 24 × 12	24 31	120	35 29	12 088	930	556	3635 3	299 1	10 15	254 0	42 2	2 68
	24 00	100	29 43	12 000	775	468	2987 3	248 9	10 08	203 5	33 9	2 63
CB 241 24 × 9	24 29	94	27 63	9 061	872	516	2683 0	220 9	9 85	102 2	22 6	1 92
	24 00	80	23 54	9 000	727	455	2229 7	185 8	9 73	82 4	18 3	1 87
CB 213 21 × 13	21 46	142	41 76	13 132	1 095	659	3403 1	317 2	9 03	385 9	58 8	3 04
	21 16	122	35 85	13 040	945	567	2883 2	272 5	8 97	322 1	49 4	3 00
CB 212 21 × 9	21 29	103	30 27	9 071	1 010	608	2268 0	213 1	8 66	119 9	26 4	1 99
	21 00	89	26 15	9 000	865	537	1919 2	182 8	8 57	99.4	22 1	1 95
CB 211 21 × 8½	21 24	73	21 46	8 295	740	455	1600 3	150 7	8 64	66 2	16 0	1 76
	21 00	63	18 52	8 250	620	410	1343 6	128 0	8 52	53 8	13 1	1 70
CB 183 18 × 11½	18 64	124	36 45	11 889	1 071	651	2227 1	239 0	7 82	281 9	47 4	2 78
	18 32	105	30 86	11 792	911	554	1852 5	202 2	7 75	231 0	39.2	2 73
CB 182 18 × 8½	18 32	85	24 97	8 838	911	526	1429 9	156 1	7 57	99 4	22 5	2 00
	18 00	70	20 56	8 750	751	438	1153 9	128 2	7 49	78 5	17 9	1 95
CB 181 18 × 7½	18 12	55	16 19	7 532	630	390	889 9	98 2	7 41	42 0	11 1	1 61
	17 90	47	13 81	7 492	520	350	736 4	82 3	7 30	33 5	9 0	1 56
CB 163 16 × 11½	16 64	114	33 51	11 629	1 035	631	1642 6	197 4	7 00	254 6	43 8	2 76
	16 32	96	28 22	11 533	875	535	1353 1	166 1	6 93	207 2	35 9	2 71
CB 162 16 × 8½	16 32	78	22 92	8 586	875	529	1042 6	127 8	6 74	87 5	20 4	1 95
	16 00	64	18 80	8 500	715	443	833 8	104 2	6 66	68 4	16 1	1 91
CB 161 16 × 7	16 25	50	14 70	7 073	628	380	655 4	80 7	6 68	34 8	9 8	1 54
	16 00	40	11 77	7 000	503	307	515 5	64 4	6 62	26 5	7 6	1 50
CB 146 14 × 16	18 69	428	125 25	16 695	3 033	1 875	6610 3	707 4	7 26	2359 5	282 7	4 34
	18 31	398	116 98	16 590	2 843	1 770	6013 7	656 9	7 17	2169 7	261 0	4 31
	17 94	370	108 78	16 475	2 658	1 635	5454 2	608 1	7 08	1986 0	241 1	4 27
	17 56	342	100 59	16 365	2 468	1 545	4911 5	559 4	6 99	1806 9	220 8	4 24

CB SECTIONS  
Elements of Sections

Section index and nominal size	Depth of section, in.	Weight per foot, lb.	Area of section, in. <sup>2</sup>	Flange		Web thickness, in.	Axis 1-1			Axis 2-2		
				Width, in.	Thickness, in.		I, in. <sup>4</sup>	S, in. <sup>3</sup>	r, in.	I, in. <sup>4</sup>	S, in. <sup>3</sup>	r, in.
CB 146 14 × 16	17 19	314	92 30	16 235	2 283	1 415	4399 4	511 9	6 90	1631 4	201 0	4 20
	16 81	287	84 37	16 130	2 093	1 310	3912 1	465 5	6 81	1466 5	181 8	4 17
	16 50	264	77 63	16 025	1 938	1 205	3526 0	427 4	6 74	1331 2	166 1	4 14
	16 25	246	72 33	15 945	1 813	1 125	3228 9	397 1	6 68	1226 6	153 9	4 12
	16 00	228	67 06	15 865	1 688	1 015	2942 4	367 8	6 62	1124 8	141 8	4 10
	15 75	211	62 07	15 800	1 563	.980	2671 4	339 2	6 56	1028 6	130 2	4 07
	15 50	193	56 73	15 710	1 438	.890	2402 4	310 0	6 51	930 1	118 4	4 05
	15 25	176	51 73	15 640	1 313	.820	2149 6	281 9	6 45	837 9	107 1	4 02
	15 00	158	46 47	15 550	1 188	.730	1900 6	253 4	6 40	745 0	95 8	4 00
	14 75	142	41 85	15 500	1 063	.680	1672 2	226 7	6 32	660 1	85 2	3 97
	16 81	320	94 12	16 710	2 093	1 890	4141 7	492 8	6 63	1635 1	195 7	4 17
CB 145 14 × 14½	14 75	136	39 08	14 740	1 063	.660	1593 0	216 0	6 31	567 7	77 0	3 77
	14 50	119	34 99	14 650	.938	.570	1373 1	189 4	6 26	491 7	67 1	3 75
	14 25	103	30 26	14 575	.813	.495	1165 8	163 6	6 21	419 7	57 6	3 72
	14 00	87	25 56	14 500	.688	.420	966 9	138 1	6 15	349 7	48 2	3 70
CB 144 14 × 12	14 18	84	24 71	12 023	.778	.451	928 4	130 9	6 13	225 5	37 5	3 02
	14 06	78	22 94	12 000	.718	.428	851 2	121 1	6 09	206 9	34 5	3 00
CB 143 14 × 10	14 19	74	21 76	10 072	.783	.450	796 8	112 3	6 05	133 5	26 5	2 48
	13 91	61	17 94	10 000	.643	.378	641 5	92 2	5 98	107 3	21 5	2 45
CB 142 14 × 8	14 06	58	17 06	8 098	.718	.406	597 9	85 0	5 92	63 7	15 7	1 93
	13 81	48	14 11	8 031	.593	.339	484 9	70 2	5 86	51 3	12 8	1 91
CB 141 14 × 6½	14 24	42	12 34	6 801	.573	.338	432 2	60 7	5 92	28 1	8 3	1 51
	14 00	34	10 00	6 750	.453	.287	339 2	48 5	5 83	21 3	6 3	1 46
CB 124 12 × 12	14 38	190	55 86	12 670	1 736	1 060	1892 5	263 2	5 82	589 7	93 1	3 25
	13 88	161	47 38	12 515	1 486	.905	1541 8	222 2	5 70	486 2	77 7	3 20
	13 38	133	39 11	12 365	1 236	.755	1221 2	182 5	5 59	389 9	63 1	3 16
	12 88	106	31 19	12 230	.986	.620	930 7	144 5	5 46	300 9	49 2	3 11
	12 62	92	27 06	12 155	.856	.545	788 9	125 0	5 40	256 4	42 2	3 08
	12 38	79	23 22	12 080	.736	.470	663 0	107 1	5 34	216 4	35 8	3 05
12 12	65	19 11	12 000	.606	.390	533 4	88 0	5 28	174 6	29 1	3 02	
CB 123 12 × 10	12 31	64	18 83	10 060	.701	.405	528 3	85 8	5 29	119 0	23 7	2 51
	12 06	53	15 59	10 000	.576	.345	426 2	70 7	5 23	96 1	19 2	2 48
CB 122 12 × 8	12 19	50	14 71	8 077	.641	.371	394 5	64 7	5 18	56 4	14 0	1 96
	11 94	49	11 77	8 000	.516	.294	310 1	51 9	5 13	44 1	11 0	1 94
CB 121 12 × 6½	12 24	38	10 59	6 565	.540	.305	280 8	45 9	5 15	23 7	7 2	1 50
	12 00	28	8 23	6 500	.420	.240	213 5	35 6	5 09	17 5	5 4	1 46
CB 103 10 × 10	11 88	136	40 03	10 575	1 498	.915	917 2	154 4	4 79	295 9	56 0	2 72
	11 38	112	32 92	10 415	1 248	.755	718 7	126 3	4 67	235 4	45 2	2 67
	10 88	89	26 13	10 275	.998	.615	542 4	99 7	4 55	180 6	35 2	2 63
	10 50	72	21 18	10 170	.808	.510	420 7	80 1	4 46	141 8	27 9	2 59
	10 25	60	17 66	10 075	.683	.415	343 7	67 1	4 41	116 5	23 1	2 57
10 00	49	14 40	10 000	.558	.340	272 9	54 6	4 35	93 0	18 6	2 54	
CB 102 10 × 8	10 12	45	13 24	8 022	.618	.350	248 6	49 1	4 33	53 2	13 3	2 00
	9 88	37	10 88	7 978	.498	.306	196 9	39 9	4 25	42 2	10 6	1 97
CB 101 10 × 5½	10 22	29	8 57	5 799	.500	.289	157 3	30 8	4 29	15 2	5 2	1 34
	10 00	23	6 77	5 750	.390	.240	120 6	24 1	4 22	11 3	3 9	1 29
CB 83 8 × 8	9 00	67	19 70	8 287	.693	.575	271 8	60 4	3 71	88 6	21 4	2 12
	8 50	48	11 11	8 117	.685	.405	183 7	43 2	3 61	60 9	15 0	2 08
	8 12	35	10 30	8 027	.493	.315	126 5	31 1	3 50	42 5	10 6	2 03
	8 00	31	9 12	8 000	.433	.288	109 7	27 4	3 47	37 0	9 2	2 01
CB 82 8 × 6½	8 03	27	7 93	6 528	.448	.273	94 1	23 4	3 44	20 8	6 4	1 62
	7 93	24	7 06	6 500	.398	.245	82 5	20 8	3 42	18 2	5 6	1 61
CB 81 8 × 5½	8 19	19	6 18	5 272	.403	.252	73 8	18 0	3 45	9 13	3 5	1 22
	8 00	17	5 00	5 250	.308	.230	56 4	14 1	3 36	6 72	2 6	1 16

**BEAMS, AMERICAN STANDARD**  
Elements of Sections

Section index and nominal size	Depth of beam, in.	Weight per foot, lb.	Area of section, in. <sup>2</sup>	Width of flange, in.	Web thickness, in.	Axis 1-1			Axis 2-2		
						I, in. <sup>4</sup>	S, in. <sup>3</sup>	r, in.	I, in. <sup>4</sup>	S, in. <sup>3</sup>	r, in.
B 18 24 × 7½	24	120.0	35.13	8.048	.798	3010.8	250.9	9.26	84.9	21.1	1.56
		115.0	33.67	7.987	.737	2940.5	215.0	9.35	82.8	20.7	1.57
		110.0	32.18	7.925	.675	2869.1	239.1	9.44	80.6	20.3	1.58
		105.9	30.98	7.875	.625	2811.5	234.3	9.53	78.9	20.0	1.60
B 1 24 × 7	24	100.0	29.25	7.217	.717	2371.8	197.6	9.05	48.4	13.4	1.29
		95.0	27.79	7.186	.686	2301.5	191.8	9.08	47.0	13.0	1.30
		90.0	26.30	7.124	.624	2230.1	185.8	9.21	45.5	12.8	1.32
		85.0	24.84	7.063	.563	2159.8	180.0	9.33	44.2	12.5	1.33
B 2 20 × 7	20	79.9	23.33	7.000	.500	2087.2	173.9	9.46	42.9	12.2	1.36
		100.0	29.20	7.273	.873	1618.3	164.8	7.51	52.4	14.4	1.34
		95.0	27.74	7.206	.800	1599.7	160.0	7.59	50.5	14.0	1.35
		90.0	26.26	7.126	.726	1550.3	155.0	7.68	48.7	13.7	1.36
B 3 20 × 6½	20	85.0	24.80	7.053	.653	1501.7	150.2	7.78	47.0	13.3	1.38
		81.4	23.74	7.000	.600	1466.3	146.6	7.86	45.8	13.1	1.39
		75.0	21.90	6.391	.641	1263.5	126.3	7.60	30.1	9.4	1.17
		70.0	20.42	6.317	.567	1214.2	121.4	7.71	28.9	9.2	1.19
B 4 18 × 6	18	65.4	19.08	6.250	.500	1169.5	116.9	7.83	27.9	8.9	1.21
		70.0	20.46	6.251	.711	917.5	101.9	6.70	24.5	7.8	1.09
		65.0	18.98	6.169	.629	877.7	97.5	6.80	23.4	7.6	1.11
		60.0	17.50	6.087	.547	837.8	93.1	6.92	22.3	7.3	1.13
B 6 15 × 6	15	54.7	15.94	6.000	.460	795.5	88.4	7.07	21.2	7.1	1.15
		75.0	21.85	6.278	.868	687.2	91.6	5.61	30.6	9.8	1.18
		70.0	20.38	6.180	.770	659.6	87.9	5.69	28.8	9.3	1.19
		65.0	18.91	6.082	.672	632.1	84.3	5.78	27.2	8.9	1.20
B 7 15 × 5½	15	60.8	17.68	6.000	.590	609.0	81.2	5.87	26.0	8.7	1.21
		55.0	16.06	5.738	.648	508.7	67.8	5.63	17.0	5.9	1.03
		50.0	14.59	5.640	.550	481.1	64.2	5.74	16.0	5.7	1.05
		45.0	13.12	5.542	.452	453.6	60.5	5.88	15.0	5.4	1.07
B 8 12 × 5½	12	42.9	12.49	5.500	.410	441.8	58.9	5.95	14.6	5.3	1.08
		55.0	16.04	5.600	.810	319.3	53.2	4.46	17.3	6.2	1.04
		50.0	14.57	5.477	.687	301.6	50.3	4.55	16.0	5.8	1.05
		45.0	13.10	5.355	.565	284.1	47.3	4.66	14.8	5.5	1.06
B 9 12 × 5	12	40.8	11.84	5.250	.460	268.9	44.8	4.77	13.8	5.3	1.08
		35.0	10.20	5.078	.428	227.0	37.8	4.72	10.0	3.9	0.99
		31.8	9.26	5.000	.350	215.8	36.0	4.83	9.5	3.8	1.01
		40.0	11.69	5.091	.741	158.0	31.6	3.68	9.4	3.7	0.90
B 10 10 × 4½	10	35.0	10.22	4.944	.594	145.8	29.2	3.78	8.5	3.4	0.91
		30.0	8.75	4.797	.447	133.5	26.7	3.91	7.6	3.2	0.93
		25.4	7.38	4.660	.310	122.1	24.4	4.07	6.9	3.0	0.97
		40.0	11.69	5.091	.741	158.0	31.6	3.68	9.4	3.7	0.90

BEAMS, AMERICAN STANDARD  
Elements of Sections

Section index and nominal size	Depth of beam, in.	Weight per foot, lb.	Area of section, in. <sup>2</sup>	Width of flange, in.	Web thickness, in.	Axis 1-1			Axis 2-2		
						<i>I</i> , in. <sup>4</sup>	<i>S</i> , in. <sup>3</sup>	<i>r</i> , in.	<i>I</i> , in. <sup>4</sup>	<i>S</i> , in. <sup>3</sup>	<i>r</i> , in.
B 12 8 × 4	8	25.5	7.43	4.262	.532	68.1	17.0	3.03	4.7	2.2	0.80
		23.0	6.71	4.171	.411	64.2	16.0	3.09	4.4	2.1	0.81
		20.5	5.97	4.079	.349	60.2	15.1	3.18	4.0	2.0	0.82
		18.4	5.34	4.000	.270	56.9	14.2	3.26	3.8	1.9	0.84
B 13 7 × 3½	7	20.0	5.83	3.860	.450	41.9	12.0	2.68	3.1	1.6	0.74
		17.5	5.09	3.755	.345	38.9	11.1	2.77	2.9	1.6	0.76
		15.3	4.43	3.660	.250	36.2	10.4	2.86	2.7	1.5	0.78
B 14 6 × 3½	6	17.25	5.02	3.565	.465	26.0	8.7	2.28	2.3	1.3	0.68
		14.75	4.29	3.443	.343	23.8	7.9	2.36	2.1	1.2	0.69
		12.5	3.61	3.330	.230	21.8	7.3	2.46	1.8	1.1	0.72
B 15 5 × 3	5	14.75	4.29	3.284	.494	15.0	6.0	1.87	1.7	1.0	0.63
		12.25	3.56	3.137	.347	13.5	5.4	1.95	1.4	0.91	0.63
		10.0	2.87	3.000	.210	12.1	4.8	2.05	1.2	0.82	0.65
B 16 4 × 2½	4	10.5	3.05	2.870	.400	7.1	3.5	1.52	1.0	0.70	0.57
		9.5	2.76	2.796	.326	6.7	3.3	1.56	0.91	0.65	0.58
		3.5	2.46	2.723	.253	6.3	3.2	1.60	0.83	0.61	0.58
		7.7	2.21	2.660	.190	6.0	3.0	1.64	0.77	0.58	0.59
B 17 3 × 2½	3	7.5	2.17	2.509	.349	2.9	1.9	1.15	0.59	0.47	0.52
		6.5	1.88	2.411	.251	2.7	1.8	1.19	0.51	0.43	0.52
		5.7	1.64	2.530	.170	2.5	1.7	1.23	0.46	0.40	0.53

CHANNELS, AMERICAN STANDARD  
Elements of Sections

Section index and nominal size	Depth of channel, in.	Weight per foot, lb.	Area of section, in. <sup>2</sup>	Width of flange, in.	Web thickness, in.	Axis 1-1			Axis 2-2			
						<i>I</i> , in. <sup>4</sup>	<i>S</i> , in. <sup>3</sup>	<i>r</i> , in.	<i>I</i> , in. <sup>4</sup>	<i>S</i> , in. <sup>3</sup>	<i>r</i> , in.	<i>y</i> , in.
C 60 18 × 4	18	58 0	16 98	4.200	.700	670.7	71 5	6.29	18.5	5 6	1 04	0 88
		51.9	15 18	4.100	.600	622.1	69 1	6.40	17.1	5 3	1.06	0.87
		45.8	13 38	4 000	.500	573.5	63.7	6 55	15 8	5 1	1 09	0 89
		42.7	12 18	3.950	.450	549.2	61 0	6.64	15.0	4.9	1 10	0 90
C 1 15 × 3½	15	55.0	16.11	3.814	.814	429.0	57.2	5 16	12 1	4 1	0 87	0 82
		50.0	14.64	3.716	.716	401.4	53.6	5 24	11.2	3 8	0 87	0 80
		45.0	13.17	3 618	.618	373 9	49 8	5 33	10 3	3 6	0 88	0 79
		40 0	11.70	3.520	.520	346 3	46 2	5 11	9 3	3 4	0 89	0 78
C 2 12 × 3	12	35 0	10 23	3.422	.422	318 7	42 5	5 58	8 4	3 2	0 91	0 79
		33.9	9.90	3.400	.400	312 6	41.7	5 62	8.2	3.2	0 91	0 79
		40 0	11.73	3.415	.755	196.5	32.8	4 09	6 6	2 5	0 75	0 72
		35 0	10 26	3 292	.632	178.8	29.8	4 18	5 9	2 3	0 76	0 69
C 3 10 × 2½	10	30.0	8 79	3.170	.510	161.2	26.9	4 28	5 2	2 1	0 77	0 68
		25.0	7.32	3 047	.387	143.5	23 9	4 43	4 5	1.9	0 79	0 68
		20.7	6.03	2 910	.280	128.1	21.4	4.61	3 9	1 7	0 81	0 70
		35 0	10.27	3 180	.820	115 2	23 0	3 31	4 6	1 9	0 67	0 69
C 4 9 × 2½	9	30 0	8 80	3 033	.673	103.0	20 6	3 42	4 0	1 7	0 67	0 65
		25 0	7 33	2 886	.526	90.7	18 1	3 52	3 4	1 5	0 68	0 62
		20 0	5 86	2 739	.379	78.5	15.7	3.66	2 8	1 3	0 70	0 61
		15.3	4 47	2 600	.240	66.9	13.4	3 87	2 3	1 2	0 72	0 64
C 5 8 × 2½	8	25 0	7 33	2.812	.612	70 5	15 7	3 10	3.0	1 4	0 61	0 61
		20 0	5 86	2 618	.418	60 6	13.5	3 22	2 4	1 2	0 65	0 59
		15.0	4 39	2 485	.285	50 7	11.3	3.40	1 9	1 0	0 67	0 59
		13.4	3.89	2.430	.230	47.3	10.5	3.49	1.8	0 97	0 67	0 61
C 6 7 × 2	7	21.25	6.23	2 619	.579	47 6	11.9	2.77	2.2	1 1	0 60	0 59
		18.75	5 49	2 527	.487	43 7	10 9	2.82	2 0	1 0	0 60	0 57
		16.25	4 76	2 435	.395	39 8	9 9	2 89	1 8	0 91	0 61	0 56
		13 75	4 02	2 343	.303	35 8	9 0	2 99	1 5	0 86	0 62	0 56
C 7 6 × 2	6	11.5	3 36	2.260	.220	32.3	8.1	3.10	1.3	0.79	0 63	0 58
		19.75	5 79	2.509	.629	33 1	9 4	2 39	1.8	0 96	0 56	0 58
		17.25	5.05	2 404	.524	30 1	8 6	2 44	1.6	0 86	0 56	0 55
		14.75	4.32	2 299	.419	27.1	7.7	2.51	1.4	0 79	0 57	0 53
C 8 5 × 1½	5	12.25	3.58	2 194	.314	24.1	6 9	2 59	1 2	0 71	0 58	0 53
		9.8	2.85	2 090	.210	21.1	6.0	2.72	0 98	0 63	0 59	0 55
		15.5	4.54	2 279	.559	19 5	6.5	2 07	1 3	0 73	0 53	0 55
		13 0	3.81	2.157	.437	17 3	5 8	2 13	1 1	0 65	0 53	0 52
C 9 4 × 1½	4	10.5	3 07	2 031	.311	15.1	5 0	2 22	0 87	0 57	0 53	0 50
		8.2	2.39	1.920	.200	13.0	4.3	2 34	0.70	0.50	0.54	0.52
		11.5	3.36	2.032	.472	10.4	4 1	1.76	0.82	0.54	0 49	0 51
		9.0	2.63	1 885	.325	8.8	3 5	1 83	0.64	0.45	0 49	0 48
C 10 3 × 1½	3	6.7	1.95	1.750	.190	7.4	3 0	1.95	0.48	0.38	0 50	0 49
		7.25	2.12	1.720	.320	4.5	2 3	1 47	0.44	0.35	0.46	0 46
		6.25	1.82	1.617	.247	4.1	2 1	1.50	0 38	0 32	0.45	0 46
		5.4	1.56	1.580	.180	3.8	1.9	1.56	0.32	0 29	0.45	0 46
C 10 3 × 1½	3	6.0	1.75	1.596	.356	2.1	1.4	1.08	0.31	0.27	0.42	0 46
		5.0	1.46	1.498	.258	1.8	1.2	1.12	0.25	0.24	0.41	0 44
		4.1	1.19	1.410	.170	1.6	1.1	1.17	0.20	0.21	0.41	0 44

EQUAL ANGLES  
Elements of Sections

Section index	Size, in.	Thick-ness, in.	Weight per foot, lb.	Area of section, in. <sup>2</sup>	Axis 1-1 and axis 2-2					
					I, in. <sup>4</sup>	S, in. <sup>3</sup>	r, in.	z, in.		
A 1	8 × 8	1½	56.9	16.73	98.0	17.5	2.42	2.41		
		1⅞	54.0	15.87	93.5	16.7	2.43	2.39		
		1	51.0	15.00	89.0	15.8	2.44	2.37		
		¾	48.1	14.12	84.3	11.9	2.14	2.34		
		⅝	45.0	13.23	79.6	14.0	2.45	2.32		
		⅜	42.0	12.34	74.7	13.1	2.46	2.30		
		⅓	38.9	11.41	69.7	12.2	2.47	2.28		
		⅔	35.8	10.53	61.6	11.2	2.48	2.25		
		⅖	32.7	9.61	59.4	10.3	2.49	2.23		
		⅜	29.6	8.68	54.1	9.3	2.50	2.21		
		½	26.4	7.75	48.6	8.4	2.51	2.19		
		A 2	6 × 6	1⅞	39.6	11.62	37.2	9.0	1.79	1.89
				1	37.4	11.00	35.5	8.6	1.80	1.86
				¾	35.3	10.37	33.7	8.1	1.80	1.84
⅝	33.1			9.73	31.9	7.6	1.81	1.82		
⅜	31.0			9.09	30.1	7.2	1.82	1.80		
⅓	28.7			8.44	28.2	6.7	1.83	1.78		
⅔	26.5			7.78	26.2	6.2	1.83	1.75		
⅖	24.2			7.11	24.2	5.7	1.84	1.73		
⅜	21.9			6.43	22.1	5.1	1.85	1.71		
½	19.6			5.75	19.9	4.6	1.86	1.68		
⅞	17.2			5.06	17.7	4.1	1.87	1.66		
⅓	14.9			4.36	15.4	3.5	1.88	1.64		
A 3	5 × 5			1	30.6	9.00	19.6	5.8	1.48	1.61
				¾	28.9	8.50	18.7	5.5	1.48	1.59
		⅝	27.2	7.98	17.8	5.2	1.49	1.57		
		⅜	25.4	7.17	16.8	4.9	1.50	1.55		
		⅓	23.6	6.94	15.7	4.5	1.50	1.52		
		⅔	21.8	6.40	14.7	4.2	1.51	1.50		
		⅖	20.0	5.86	13.6	3.9	1.52	1.48		
		⅜	18.1	5.31	12.4	3.5	1.53	1.46		
		½	16.2	4.75	11.3	3.2	1.54	1.43		
		⅞	14.3	4.18	10.0	2.8	1.55	1.41		
		⅓	12.3	3.61	8.7	2.4	1.56	1.39		
		A 4	4 × 4	¾	19.9	5.84	8.1	3.0	1.18	1.29
				⅝	18.5	5.44	7.7	2.8	1.19	1.27
				⅜	17.1	5.03	7.2	2.6	1.19	1.25
⅓	15.7			4.61	6.7	2.4	1.20	1.23		
⅔	14.3			4.18	6.1	2.2	1.21	1.21		
⅖	12.8			3.75	5.6	2.0	1.22	1.18		
⅜	11.3			3.31	5.0	1.8	1.23	1.16		
½	9.8			2.86	4.4	1.5	1.23	1.14		
⅞	8.2			2.40	3.7	1.3	1.24	1.12		
⅓	6.6			1.94	3.0	1.0	1.25	1.09		

EQUAL ANGLES  
Elements of Sections

Section index	Size, in.	Thick-ness, in.	Weight per foot, lb.	Area of section, in. <sup>2</sup>	Axis 1-1 and axis 2-2			
					<i>I</i> , in. <sup>4</sup>	<i>S</i> , in. <sup>3</sup>	<i>r</i> , in.	<i>z</i> , in.
A 5	3½ × 3½	½	17.1	5.03	5.3	2.3	1.02	1.17
		⅜	16.0	4.69	5.0	2.1	1.03	1.15
		¼	14.8	4.34	4.7	2.0	1.04	1.12
		⅓	13.6	3.98	4.3	1.8	1.04	1.10
		⅕	12.4	3.62	4.0	1.6	1.05	1.08
		⅙	11.1	3.25	3.6	1.5	1.06	1.08
		⅛	9.8	2.87	3.3	1.3	1.07	1.04
		1/10	8.5	2.48	2.9	1.2	1.07	1.01
		1/12	7.2	2.09	2.5	0.98	1.08	0.99
		1/16	5.8	1.69	2.0	0.79	1.09	0.97
A 7	3 × 3	½	11.5	3.36	2.6	1.3	0.88	0.98
		⅜	10.4	3.06	2.4	1.2	0.89	0.95
		¼	9.4	2.75	2.2	1.1	0.90	0.93
		⅕	8.3	2.43	2.0	0.95	0.91	0.91
		⅙	7.2	2.11	1.8	0.83	0.91	0.89
		1/10	6.1	1.78	1.5	0.71	0.92	0.87
		1/12	4.9	1.44	1.2	0.58	0.93	0.84
A 9	2½ × 2½	½	7.7	2.25	1.2	0.73	0.74	0.81
		⅜	6.8	2.00	1.1	0.65	0.75	0.78
		¼	5.9	1.73	0.98	0.57	0.75	0.76
		⅕	5.0	1.47	0.85	0.48	0.76	0.74
		⅙	4.1	1.19	0.70	0.39	0.77	0.72
		1/10	3.07	0.90	0.55	0.30	0.78	0.69
		1/12	2.08	0.61	0.38	0.20	0.79	0.67
A 11	2 × 2	1/16	5.3	1.56	0.54	0.40	0.59	0.66
		1/20	4.7	1.36	0.48	0.35	0.59	0.64
		1/25	3.92	1.15	0.42	0.30	0.60	0.61
		1/30	3.19	0.94	0.35	0.25	0.61	0.59
		1/40	2.44	0.71	0.28	0.19	0.62	0.57
		1/50	1.65	0.48	0.19	0.13	0.63	0.55
A 12	1½ × 1½	1/16	3.39	1.00	0.27	0.23	0.52	0.55
		1/20	2.77	0.81	0.23	0.19	0.53	0.53
		1/25	2.12	0.62	0.18	0.14	0.54	0.51
		1/30	1.44	0.42	0.13	0.10	0.55	0.48
A 13	1½ × 1½	1/40	3.35	0.98	0.19	0.19	0.44	0.51
		1/50	2.86	0.84	0.16	0.16	0.44	0.49
		1/60	2.34	0.69	0.14	0.13	0.45	0.47
		1/80	1.80	0.53	0.11	0.10	0.46	0.44
		1/100	1.23	0.36	0.08	0.07	0.46	0.42
A 15	1½ × 1½	1/16	2.33	0.68	0.09	0.11	0.36	0.42
		1/20	1.92	0.56	0.08	0.09	0.37	0.40
		1/25	1.48	0.43	0.06	0.07	0.38	0.38
		1/30	1.01	0.30	0.04	0.05	0.38	0.35
A 16	1 × 1	1/20	1.49	0.44	0.04	0.06	0.29	0.34
		1/25	1.16	0.34	0.03	0.04	0.30	0.32
		1/30	0.80	0.23	0.02	0.03	0.31	0.30

UNEQUAL ANGLES  
Elements of Sections

Section index	Size, in.	Thick-ness, in	Weight per foot, lb.	Area of section, in <sup>2</sup>	Axis 1-1				Axis 2-2					
					<i>I</i> , in <sup>4</sup>	<i>S</i> , in <sup>3</sup>	<i>r</i> , in.	<i>r</i> , in.	<i>I</i> , in <sup>4</sup>	<i>S</i> , in <sup>3</sup>	<i>r</i> , in.	<i>y</i> , in.		
A 18	8 × 6	1 1/16	49 3	14 48	88 9	16 8	2 48	2 70	12 5	9 9	1 71	1 70		
		1 1/8	46 8	13 75	81 9	15 9	2 48	2 68	10 7	9 4	1 72	1 68		
		1 1/4	41 7	12 25	70 6	14 3	2 49	2 65	38 8	8 9	1 73	1 65		
		1 1/2	39 1	11 18	72 3	13 1	2 50	2 63	36 8	8 4	1 73	1 63		
		1 3/8	36 5	10 72	67 9	12 5	2 51	2 61	34 9	7 9	1 74	1 61		
		1 1/2	33 8	9 94	63 1	11 7	2 52	2 59	32 8	7 4	1 75	1 59		
		1 5/8	31 2	9 15	58 8	10 8	2 53	2 56	30 7	6 9	1 76	1 56		
		1 3/4	28 5	8 36	54 1	9 9	2 54	2 52	28 6	6 4	1 77	1 54		
		1 7/8	25 7	7 56	49 3	8 9	2 55	2 50	21 0	5 3	1 78	1 50		
		1 15/16	23 0	6 75	44 3	8 0	2 56	2 47	21 7	4 8	1 79	1 47		
		1 1/8	20 2	5 93	39 2	7 1	2 57	2 45	19 3	4 2	1 80	1 45		
		A 50	8 × 4	1 1/16	37 4	11 00	69 6	14 1	2 52	3 05	11 6	3 9	1 03	1 05
1 1/8	35 3			10 37	66 1	13 3	2 52	3 02	11 1	3 7	1 03	1 02		
1 1/4	33 1			9 73	62 1	12 5	2 53	3 00	10 5	3 5	1 04	1 00		
1 1/2	31 0			9 09	58 7	11 7	2 54	2 98	10 0	3 3	1 05	0 98		
1 3/8	28 7			8 44	54 9	10 9	2 55	2 95	9 4	3 1	1 05	0 95		
1 1/2	26 5			7 78	51 0	10 0	2 56	2 93	8 7	2 8	1 06	0 93		
1 5/8	24 2			7 11	46 9	9 2	2 57	2 91	8 1	2 6	1 07	0 91		
1 3/4	21 9			6 43	42 8	8 4	2 57	2 88	7 4	2 4	1 07	0 88		
1 7/8	19 6			5 75	38 5	7 5	2 59	2 86	6 7	2 2	1 08	0 86		
1 15/16	17 2			5 06	34 1	6 6	2 60	2 83	6 0	1 9	1 09	0 83		
A 60	7 × 4			1 1/16	34 0	10 00	47 7	10 8	2 18	2 60	11 2	3 9	1 06	1 10
				1 1/8	32 1	9 44	45 4	10 3	2 19	2 58	10 7	3 7	1 07	1 08
		1 1/4	30 2	8 86	42 9	9 7	2 20	2 55	10 2	3 5	1 07	1 05		
		1 1/2	28 2	8 28	40 4	9 0	2 21	2 53	9 6	3 2	1 08	1 03		
		1 3/8	26 2	7 69	37 8	8 4	2 22	2 51	9 1	3 0	1 09	1 01		
		1 1/2	24 2	7 09	35 1	7 8	2 23	2 49	8 5	2 8	1 09	0 99		
		1 5/8	22 1	6 49	32 4	7 1	2 24	2 46	7 8	2 6	1 10	0 96		
		1 3/4	20 0	5 88	29 6	6 5	2 24	2 44	7 2	2 4	1 11	0 94		
		1 7/8	17 9	5 25	26 7	5 8	2 25	2 42	6 5	2 1	1 11	0 92		
		1 15/16	15 8	4 63	23 7	5 1	2 26	2 39	5 8	1 9	1 12	0 89		
		1 1/8	13 6	3 99	20 6	4 4	2 27	2 37	5 1	1 6	1 13	0 87		
		A 20	6 × 4	1 1/16	30 6	9 00	30 8	8 0	1 85	2 17	10 8	3 8	1 09	1 17
1 1/8	28 9			8 50	29 3	7 6	1 86	2 14	10 3	3 6	1 10	1 14		
1 1/4	27 2			7 98	27 7	7 2	1 86	2 12	9 8	3 4	1 11	1 12		
1 1/2	25 4			7 47	26 1	6 7	1 87	2 10	9 2	3 2	1 11	1 10		
1 3/8	23 6			6 94	24 5	6 2	1 88	2 08	8 7	3 0	1 12	1 08		
1 1/2	21 8			6 40	22 8	5 8	1 89	2 06	8 1	2 8	1 13	1 06		
1 5/8	20 0			5 86	21 1	5 3	1 90	2 03	7 5	2 5	1 13	1 03		
1 3/4	18 1			5 31	19 3	4 8	1 90	2 01	6 9	2 3	1 14	1 01		
1 7/8	16 2			4 75	17 4	4 3	1 91	1 99	6 3	2 1	1 15	0 99		
1 15/16	14 3			4 18	15 5	3 8	1 92	1 96	5 6	1 8	1 16	0 96		
1 1/8	12 3			3 61	13 5	3 3	1 93	1 94	4 9	1 6	1 17	0 94		
A 23	5 × 3 1/2			1 1/16	22 7	6 67	15 7	4 9	1 53	1 79	6 2	2 5	0 96	1 04
		1 1/8	21 3	6 25	14 8	4 6	1 54	1 77	5 9	2 4	0 97	1 02		
		1 1/4	19 8	5 81	13 9	4 3	1 55	1 75	5 6	2 2	0 98	1 00		
		1 1/2	18 3	5 37	13 0	4 0	1 56	1 72	5 2	2 1	0 98	0 97		
		1 3/8	16 8	4 92	12 0	3 7	1 56	1 70	4 8	1 9	0 99	0 95		
		1 1/2	15 2	4 47	11 0	3 3	1 57	1 68	4 4	1 7	1 00	0 93		
		1 5/8	13 6	4 00	10 0	3 0	1 58	1 66	4 0	1 6	1 01	0 91		
		1 3/4	12 0	3 53	8 9	2 6	1 59	1 63	3 6	1 4	1 01	0 88		
		1 7/8	10 4	3 05	7 8	2 3	1 60	1 61	3 2	1 2	1 02	0 86		
		1 15/16	8 7	2 56	6 6	1 9	1 61	1 59	2 7	1 0	1 03	0 84		
		A 26	4 × 3 1/2	1 1/16	18 5	5 43	7 8	2 9	1 19	1 36	5 5	2 3	1 01	1 11
				1 1/8	17 3	5 06	7 3	2 8	1 20	1 34	5 2	2 1	1 01	1 09
1 1/4	16 0			4 68	6 9	2 6	1 21	1 32	4 9	2 0	1 02	1 07		
1 1/2	14 7			4 30	6 4	2 4	1 22	1 29	4 5	1 8	1 03	1 04		
1 3/8	13 3			3 90	5 9	2 1	1 23	1 27	4 2	1 7	1 03	1 02		
1 1/2	11 9			3 50	5 3	1 9	1 23	1 25	3 8	1 5	1 04	1 00		
1 5/8	10 6			3 09	4 8	1 7	1 24	1 23	3 4	1 3	1 05	0 98		
1 3/4	9 1			2 67	4 2	1 5	1 25	1 21	3 0	1 2	1 06	0 96		
1 7/8	7 7			2 25	3 6	1 3	1 26	1 18	2 6	1 0	1 07	0 93		

UNEQUAL ANGLES  
Elements of Sections

Section index	Size, in.	Thick-ness, in.	Weight per foot, lb.	Area of section, in. <sup>2</sup>	Axis 1-1				Axis 2-2			
					I, in. <sup>4</sup>	S, in. <sup>3</sup>	r, in.	x, in.	I, in. <sup>4</sup>	S, in. <sup>3</sup>	r, in.	y, in.
A 27	4 × 3	$\frac{1}{2}$	17 1	5.03	7 3	2 9	1.21	1.44	3 5	1 7	0 83	0 94
		$\frac{3}{8}$	16 0	4.69	6 9	2 7	1.22	1.42	3 3	1 6	0 84	0 92
		$\frac{1}{4}$	14 8	4 34	6 5	2 5	1.22	1.39	3 1	1 5	0 84	0 89
		$\frac{3}{16}$	13.6	3 98	6 0	2 3	1.23	1.37	2 9	1 4	0 85	0 87
		$\frac{1}{8}$	12 4	3 62	5 6	2 1	1 24	1.35	2 7	1 2	0 86	0 85
		$\frac{3}{32}$	11 1	3 25	5 0	1 9	1.25	1.33	2 4	1 1	0 86	0 83
		$\frac{1}{16}$	9 8	2 87	4 5	1 7	1.25	1.30	2 2	1 0	0 87	0 80
		$\frac{3}{64}$	8 5	2 48	4 0	1 5	1.26	1.28	1 9	0 87	0 88	0 78
		$\frac{1}{32}$	7.2	2 09	3 4	1 2	1 27	1.26	1 7	0 71	0 89	0 76
		$\frac{1}{16}$	5.8	1.69	2.8	1.0	1.28	1.24	1.4	0 60	0 89	0 71
A 28	$3\frac{1}{2} \times 3$	$\frac{1}{2}$	15 8	4.62	5 0	2 2	1.04	1.23	3 3	1 7	0 85	0 98
		$\frac{3}{8}$	14 7	4 31	4 7	2 1	1 04	1.21	3 1	1 5	0 85	0 96
		$\frac{1}{4}$	13 6	4 00	4 4	1 9	1.05	1 19	3 0	1 4	0 86	0 94
		$\frac{3}{16}$	12 5	3 67	4 1	1 8	1 06	1 17	2 8	1 3	0 87	0 92
		$\frac{1}{8}$	11 4	3 34	3 8	1 6	1.07	1.15	2 5	1 2	0 87	0 90
		$\frac{3}{32}$	10 2	3 00	3 5	1 5	1.07	1 13	2 3	1 1	0 88	0 88
		$\frac{1}{16}$	9 1	2 65	3 1	1 3	1.08	1.10	2 1	0 98	0 89	0 85
		$\frac{3}{64}$	7 9	2 30	2 7	1 1	1.09	1.08	1 8	0 85	0 90	0 83
		$\frac{1}{32}$	6.6	1 93	2 3	0 96	1.10	1.06	1 6	0 72	0 90	0 81
		$\frac{1}{16}$	5 4	1 56	1 9	0 78	1.11	1.04	1 3	0 58	0 91	0 79
A 32	$3 \times 2\frac{1}{2}$	$\frac{3}{8}$	9 5	2 78	2 3	1 2	0 91	1 02	1 4	0 82	0 72	0 77
		$\frac{1}{4}$	8 5	2 50	2 1	1 0	0 91	1 00	1 3	0 74	0 72	0 75
		$\frac{3}{16}$	7.6	2 21	1 9	0 93	0 92	0 98	1 2	0 66	0 73	0 73
		$\frac{1}{8}$	6 6	1 92	1 7	0 81	0 93	0 96	1 0	0 58	0 74	0 71
		$\frac{3}{32}$	5 6	1 62	1 4	0 69	0 94	0 93	0 90	0 49	0 74	0 68
		$\frac{1}{16}$	4 5	1 31	1 2	0 56	0 95	0 91	0 74	0 40	0 75	0 66
		$\frac{3}{64}$	3.39	1 00	0 91	0 43	0 95	0 89	0 58	0 31	0 76	0 64
A 35	$2\frac{1}{2} \times 2$	$\frac{1}{2}$	6 8	2 00	1 1	0 70	0 75	0 88	0 64	0 46	0 56	0 63
		$\frac{3}{8}$	6 1	1 78	1 0	0 62	0 76	0 85	0 58	0 41	0 68	0 60
		$\frac{1}{4}$	5 3	1 55	0 91	0 55	0 77	0 83	0 51	0 36	0 58	0 58
		$\frac{3}{16}$	4 5	1 31	0 79	0 47	0 78	0 81	0 45	0 31	0 58	0 56
		$\frac{1}{8}$	3 62	1 06	0 65	0 38	0 78	0 79	0 37	0 25	0 59	0 54
		$\frac{3}{32}$	2 75	0 81	0 51	0 29	0 79	0 76	0 29	0 20	0 60	0 51
A 37	$2 \times 1\frac{1}{2}$	$\frac{1}{2}$	1 86	0 55	0 35	0 20	0 80	0 74	0 20	0 13	0 61	0 40
		$\frac{3}{8}$	3 99	1 17	0 43	0 34	0 61	0 71	0 21	0 20	0 42	0 46
		$\frac{1}{4}$	3 39	1 00	0 38	0 29	0 62	0 69	0 18	0 17	0 42	0 44
		$\frac{3}{16}$	2 77	0 81	0 32	0 24	0 62	0 66	0 15	0 14	0 43	0 41
		$\frac{1}{8}$	2 12	0 62	0 25	0 18	0 63	0 64	0 12	0 11	0 44	0 39
A 39	$1\frac{1}{2} \times 1\frac{1}{2}$	$\frac{1}{2}$	1 44	0 42	0 17	0 13	0 64	0 62	0 09	0 08	0 45	0 37
		$\frac{3}{8}$	2 34	0 69	0 20	0 18	0 54	0 60	0 09	0 10	0 35	0 35
		$\frac{1}{4}$	1 80	0 53	0 16	0 14	0 55	0 58	0 07	0 08	0 36	0 33
		$\frac{3}{16}$	1 23	0 36	0 11	0 09	0 56	0 56	0 05	0 05	0 37	0 31

ELEMENTS OF SECTIONS

SQUARE  
Axis of moments  
through center

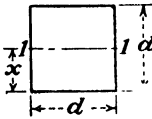

$$A = d^2$$

$$x = \frac{d}{2}$$

$$I_{1-1} = \frac{d^4}{12}$$

$$S_{1-1} = \frac{d^3}{6}$$

$$r_{1-1} = \frac{d}{\sqrt{12}} = 0.288675d$$

---

SQUARE  
Axis of moments  
on base

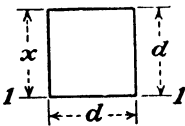

$$A = d^2$$

$$x = d$$

$$I_{1-1} = \frac{d^4}{3}$$

$$S_{1-1} = \frac{d^3}{3}$$

$$r_{1-1} = \frac{d}{\sqrt{3}} = 0.577350d$$

---

TRIANGLE  
Axis of moments  
through center of  
gravity

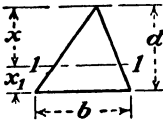

$$A = \frac{bd}{2}$$

$$x = \frac{2d}{3}$$

$$I_{1-1} = \frac{bd^3}{36}$$

$$S_{1-1} = \frac{bd^2}{24}$$

$$r_{1-1} = \frac{d}{\sqrt{18}} = 0.235702d$$

---

TRIANGLE  
Axis of moments on  
base

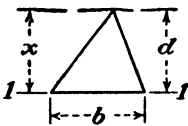

$$A = \frac{bd}{2}$$

$$x = 2d$$

$$I_{1-1} = \frac{bd^3}{12}$$

$$S_{1-1} = \frac{bd^2}{12}$$

$$r_{1-1} = \frac{d}{\sqrt{6}} = 0.408248d$$

---

RECTANGLE  
Axis of moments  
through center

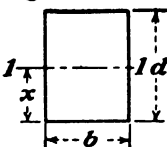

$$A = bd$$

$$x = \frac{d}{2}$$

$$I_{1-1} = \frac{bd^3}{12}$$

$$S_{1-1} = \frac{bd^2}{6}$$

$$r_{1-1} = \frac{d}{\sqrt{12}} = 0.288675d$$

---

ELEMENTS OF SECTIONS

RECTANGLE  
Axis of moments on  
base

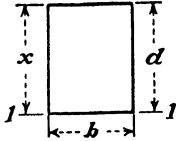

$$A = bd$$

$$x = \frac{d}{2}$$

$$I_{1-1} = \frac{bd^3}{3}$$

$$S_{1-1} = \frac{bd^2}{3}$$

$$r_{1-1} = \frac{d}{\sqrt{3}} = 0.577350d$$

CIRCLE  
Axis of moments  
through center

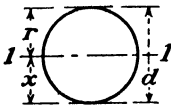

$$A = \frac{\pi d^2}{4} = \pi r^2 = 0.78540d^2 = 3.14159r^2$$

$$x = \frac{d}{2} = r$$

$$I_{1-1} = \frac{\pi d^4}{64} = \frac{\pi r^4}{4} = 0.04909d^4 = 0.78540r^4$$

$$S_{1-1} = \frac{\pi d^3}{32} = \frac{\pi r^3}{4} = 0.09818d^3 = 0.78540r^3$$

$$r_{1-1} = \frac{d}{4} = \frac{r}{2}$$

HALF CIRCLE  
Axis of moments  
through center of  
gravity

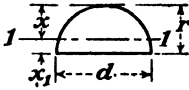

$$A = \frac{\pi r^2}{2} = 1.57080r^2$$

$$x = r \left( 1 - \frac{4}{3\pi} \right) = 0.57559r \quad x_1 = \frac{4r}{3\pi} = 0.42441r$$

$$I_{1-1} = r^4 \left( \frac{\pi}{8} - \frac{8}{9\pi} \right) = 0.10976r^4$$

$$S_{1-1} = \frac{r^3}{24} \frac{(9\pi^2 - 64)}{(3\pi - 4)} = 0.19069r^3$$

$$r_{1-1} = r \frac{\sqrt{9\pi^2 - 64}}{6\pi} = 0.26434r$$

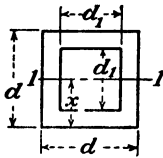

$$A = d^2 - d_1^2$$

$$x = \frac{d}{2}$$

$$I_{1-1} = \frac{d^4 - d_1^4}{12}$$

$$S_{1-1} = \frac{d^4 - d_1^4}{6d}$$

$$r_{1-1} = \sqrt{\frac{d^2 + d_1^2}{12}}$$

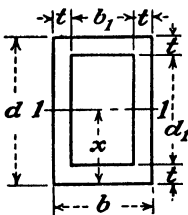

$$A = bd - b_1d_1$$

$$x = \frac{d}{2}$$

$$I_{1-1} = \frac{bd^3 - b_1d_1^3}{12}$$

$$S_{1-1} = \frac{bd^3 - b_1d_1^3}{6d}$$

$$r_{1-1} = \sqrt{\frac{bd^3 - b_1d_1^3}{12A}}$$

ELEMENTS OF SECTIONS

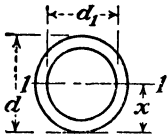

$$A = \frac{\pi(d^2 - d_1^2)}{4}$$

$$x = \frac{d}{2}$$

$$I_{1-1} = \frac{\pi(d^4 - d_1^4)}{64}$$

$$S_{1-1} = \frac{\pi(d^3 - d_1^3)}{32d}$$

$$r_{1-1} = \sqrt{\frac{d^2 + d_1^2}{4}}$$

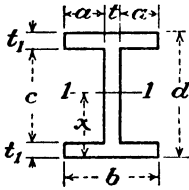

$$A = bd - 2ac$$

$$x = \frac{d}{2}$$

$$I_{1-1} = \frac{bd^3 - 2ac^3}{12}$$

$$S_{1-1} = \frac{bd^2 - 2ac^2}{6d}$$

$$r_{1-1} = \sqrt{\frac{bd^3 - 2ac^3}{12A}}$$

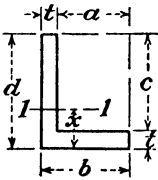

$$A = t(a + d)$$

$$x = \frac{1}{2}d^2t + \frac{1}{2}t^2a$$

$$I_{1-1} = \frac{td^3}{3} + \frac{at^3}{3} - Ax^2$$

$$S_{1-1} = \frac{I}{d - \bar{x}}$$

$$r_{1-1} = \sqrt{\frac{I}{A}}$$

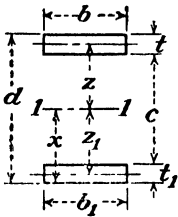

$$A = bt + b_1t_1$$

$$x = \frac{bt(d - \frac{1}{2}t) + \frac{1}{2}b_1t_1^2}{A}$$

$$I_{1-1} = \frac{bt^3}{12} + btz^2 + \frac{b_1t_1^3}{12} + b_1t_1z_1^2$$

$$S_{1-1} = \frac{I}{x}$$

$$r_{1-1} = \sqrt{\frac{I}{A}}$$

NATURAL TRIGONOMETRIC FUNCTIONS

Degrees	Sines							Cosines
	0'	10'	20'	30'	40'	50'	60'	
0	0.00000	0.00291	0.00582	0.00873	0.01164	0.01454	0.01745	89
1	0.01745	0.02036	0.02327	0.02618	0.02908	0.03199	0.03490	88
2	0.03490	0.03781	0.04071	0.04362	0.04653	0.04943	0.05234	87
3	0.05234	0.05524	0.05814	0.06105	0.06395	0.06685	0.06976	86
4	0.06976	0.07266	0.07556	0.07846	0.08136	0.08426	0.08716	85
5	0.08716	0.09005	0.09295	0.09585	0.09874	0.10164	0.10453	84
6	0.10453	0.10742	0.11031	0.11320	0.11609	0.11898	0.12187	83
7	0.12187	0.12476	0.12764	0.13053	0.13341	0.13629	0.13917	82
8	0.13917	0.14205	0.14493	0.14781	0.15069	0.15356	0.15643	81
9	0.15643	0.15931	0.16218	0.16505	0.16792	0.17078	0.17365	80
10	0.17365	0.17651	0.17937	0.18224	0.18509	0.18795	0.19081	79
11	0.19081	0.19366	0.19652	0.19937	0.20222	0.20507	0.20791	78
12	0.20791	0.21076	0.21360	0.21644	0.21928	0.22212	0.22495	77
13	0.22495	0.22778	0.23062	0.23345	0.23627	0.23910	0.24192	76
14	0.24192	0.24474	0.24756	0.25038	0.25320	0.25601	0.25882	75
15	0.25882	0.26163	0.26443	0.26721	0.27004	0.27284	0.27564	74
16	0.27564	0.27843	0.28123	0.28402	0.28680	0.28959	0.29237	73
17	0.29237	0.29515	0.29793	0.30071	0.30348	0.30625	0.30902	72
18	0.30902	0.31178	0.31454	0.31730	0.32006	0.32282	0.32557	71
19	0.32557	0.32832	0.33106	0.33381	0.33655	0.33929	0.34202	70
20	0.34202	0.34475	0.34748	0.35021	0.35293	0.35565	0.35837	69
21	0.35837	0.36108	0.36379	0.36650	0.36921	0.37191	0.37461	68
22	0.37461	0.37730	0.37999	0.38268	0.38537	0.38805	0.39073	67
23	0.39073	0.39341	0.39608	0.39875	0.40142	0.40408	0.40674	66
24	0.40674	0.40939	0.41204	0.41469	0.41734	0.41998	0.42262	65
25	0.42262	0.42525	0.42788	0.43051	0.43313	0.43575	0.43837	64
26	0.43837	0.44098	0.44359	0.44620	0.44880	0.45140	0.45399	63
27	0.45399	0.45658	0.45917	0.46175	0.46433	0.46690	0.46947	62
28	0.46947	0.47204	0.47460	0.47716	0.47971	0.48226	0.48481	61
29	0.48481	0.48735	0.48989	0.49242	0.49495	0.49748	0.50000	60
30	0.50000	0.50252	0.50503	0.50754	0.51004	0.51254	0.51504	59
31	0.51504	0.51753	0.52002	0.52250	0.52498	0.52745	0.52992	58
32	0.52992	0.53238	0.53484	0.53730	0.53975	0.54220	0.54464	57
33	0.54464	0.54708	0.54951	0.55194	0.55436	0.55678	0.55919	56
34	0.55919	0.56160	0.56401	0.56641	0.56880	0.57119	0.57358	55
35	0.57358	0.57596	0.57833	0.58070	0.58307	0.58543	0.58779	54
36	0.58779	0.59014	0.59248	0.59482	0.59716	0.59949	0.60182	53
37	0.60182	0.60414	0.60645	0.60876	0.61107	0.61337	0.61566	52
38	0.61566	0.61795	0.62024	0.62251	0.62479	0.62706	0.62932	51
39	0.62932	0.63158	0.63383	0.63608	0.63832	0.64056	0.64279	50
40	0.64279	0.64501	0.64723	0.64945	0.65166	0.65386	0.65606	49
41	0.65606	0.65825	0.66044	0.66262	0.66480	0.66697	0.66913	48
42	0.66913	0.67129	0.67344	0.67559	0.67773	0.67987	0.68200	47
43	0.68200	0.68412	0.68624	0.68835	0.69046	0.69256	0.69466	46
44	0.69466	0.69675	0.69883	0.70091	0.70298	0.70505	0.70711	45
Sines	60'	50'	40'	30'	20'	10'	0'	Degrees
	Cosines							

NATURAL TRIGONOMETRIC FUNCTIONS

Degrees	Cosines							Sines
	0'	10'	20'	30'	40'	50'	60'	
0	1.00000	1.00000	0.99998	0.99996	0.99993	0.99989	0.99985	89
1	0.99985	0.99979	0.99973	0.99966	0.99958	0.99949	0.99939	88
2	0.99939	0.99929	0.99917	0.99905	0.99892	0.99878	0.99863	87
3	0.99863	0.99847	0.99831	0.99813	0.99795	0.99776	0.99756	86
4	0.99756	0.99736	0.99714	0.99692	0.99668	0.99644	0.99619	85
5	0.99619	0.99594	0.99567	0.99540	0.99511	0.99482	0.99452	84
6	0.99452	0.99421	0.99390	0.99357	0.99324	0.99290	0.99255	83
7	0.99255	0.99219	0.99182	0.99144	0.99106	0.99067	0.99027	82
8	0.99027	0.98986	0.98941	0.98892	0.98838	0.98784	0.98729	81
9	0.98729	0.98673	0.98616	0.98557	0.98495	0.98431	0.98366	80
10	0.98416	0.98340	0.98258	0.98172	0.98082	0.97988	0.97891	79
11	0.98172	0.98082	0.97988	0.97891	0.97792	0.97690	0.97586	78
12	0.97891	0.97785	0.97673	0.97556	0.97435	0.97311	0.97185	77
13	0.97435	0.97311	0.97185	0.97056	0.96924	0.96789	0.96652	76
14	0.97056	0.96924	0.96789	0.96652	0.96512	0.96370	0.96227	75
15	0.96227	0.96082	0.95935	0.95786	0.95635	0.95482	0.95327	74
16	0.95327	0.95172	0.95015	0.94856	0.94695	0.94532	0.94368	73
17	0.94368	0.94201	0.94032	0.93862	0.93690	0.93516	0.93341	72
18	0.93341	0.93165	0.92988	0.92809	0.92628	0.92445	0.92260	71
19	0.92260	0.92075	0.91889	0.91701	0.91511	0.91319	0.91126	70
20	0.91126	0.90932	0.90737	0.90540	0.90342	0.90142	0.89940	69
21	0.89940	0.89737	0.89532	0.89325	0.89116	0.88905	0.88692	68
22	0.88692	0.88477	0.88260	0.88041	0.87820	0.87597	0.87372	67
23	0.87372	0.87145	0.86916	0.86685	0.86452	0.86217	0.85981	66
24	0.85981	0.85742	0.85501	0.85258	0.85013	0.84766	0.84517	65
25	0.84517	0.84266	0.84013	0.83758	0.83501	0.83242	0.82981	64
26	0.82981	0.82718	0.82453	0.82186	0.81917	0.81646	0.81373	63
27	0.81373	0.81100	0.80825	0.80548	0.80269	0.79988	0.79705	62
28	0.79705	0.79420	0.79133	0.78844	0.78552	0.78258	0.77962	61
29	0.77962	0.77664	0.77364	0.77061	0.76756	0.76449	0.76140	60
30	0.76140	0.75830	0.75518	0.75204	0.74888	0.74569	0.74248	59
31	0.74248	0.73925	0.73600	0.73273	0.72944	0.72612	0.72278	58
32	0.72278	0.71943	0.71606	0.71267	0.70925	0.70581	0.70235	57
33	0.70235	0.69888	0.69539	0.69188	0.68835	0.68480	0.68123	56
34	0.68123	0.67764	0.67402	0.67038	0.66672	0.66303	0.65932	55
35	0.65932	0.65559	0.65183	0.64804	0.64422	0.64038	0.63652	54
36	0.63652	0.63266	0.62877	0.62486	0.62092	0.61696	0.61298	53
37	0.61298	0.60899	0.60497	0.60093	0.59687	0.59278	0.58867	52
38	0.58867	0.58454	0.58038	0.57619	0.57197	0.56772	0.56348	51
39	0.56348	0.55921	0.55491	0.55058	0.54622	0.54183	0.53741	50
40	0.53741	0.53296	0.52848	0.52397	0.51943	0.51486	0.51027	49
41	0.51027	0.50566	0.50102	0.49635	0.49165	0.48692	0.48217	48
42	0.48217	0.47741	0.47262	0.46780	0.46295	0.45807	0.45317	47
43	0.45317	0.44826	0.44332	0.43835	0.43335	0.42832	0.42327	46
44	0.42327	0.41821	0.41312	0.40800	0.40285	0.39767	0.39246	45
Cosines	60'	50'	40'	30'	20'	10'	0'	Degrees
	Sines							

NATURAL TRIGONOMETRIC FUNCTIONS

Degrees	Tangents							Cotangents
	0'	10'	20'	30'	40'	50'	60'	
0	0.00000	0.00291	0.00582	0.00873	0.01164	0.01455	0.01746	89
1	0.01746	0.02036	0.02328	0.02619	0.02910	0.03201	0.03492	88
2	0.03492	0.03783	0.04075	0.04366	0.04658	0.04949	0.05241	87
3	0.05241	0.05533	0.05824	0.06116	0.06408	0.06700	0.06993	86
4	0.06993	0.07285	0.07578	0.07870	0.08163	0.08456	0.08749	85
5	0.08749	0.09042	0.09335	0.09629	0.09923	0.10216	0.10510	84
6	0.10510	0.10805	0.11099	0.11394	0.11688	0.11983	0.12278	83
7	0.12278	0.12574	0.12869	0.13165	0.13461	0.13758	0.14054	82
8	0.14054	0.14351	0.14648	0.14945	0.15243	0.15540	0.15838	81
9	0.15838	0.16137	0.16435	0.16734	0.17033	0.17333	0.17633	80
10	0.17633	0.17933	0.18233	0.18534	0.18835	0.19136	0.19438	79
11	0.19438	0.19740	0.20042	0.20345	0.20648	0.20952	0.21256	78
12	0.21256	0.21560	0.21864	0.22169	0.22475	0.22781	0.23087	77
13	0.23087	0.23393	0.23700	0.24008	0.24316	0.24624	0.24933	76
14	0.24933	0.25242	0.25552	0.25862	0.26172	0.26483	0.26795	75
15	0.26795	0.27107	0.27419	0.27732	0.28046	0.28360	0.28675	74
16	0.28675	0.28990	0.29305	0.29621	0.29938	0.30255	0.30573	73
17	0.30573	0.30891	0.31210	0.31530	0.31850	0.32171	0.32492	72
18	0.32492	0.32814	0.33136	0.33460	0.33783	0.34108	0.34433	71
19	0.34433	0.34758	0.35085	0.35412	0.35740	0.36068	0.36397	70
20	0.36397	0.36727	0.37057	0.37388	0.37720	0.38053	0.38386	69
21	0.38386	0.38721	0.39055	0.39391	0.39727	0.40065	0.40403	68
22	0.40403	0.40741	0.41081	0.41421	0.41763	0.42105	0.42447	67
23	0.42447	0.42791	0.43136	0.43481	0.43828	0.44175	0.44523	66
24	0.44523	0.44872	0.45222	0.45573	0.45924	0.46277	0.46631	65
25	0.46631	0.46985	0.47341	0.47698	0.48055	0.48414	0.48773	64
26	0.48773	0.49134	0.49495	0.49858	0.50222	0.50587	0.50953	63
27	0.50953	0.51320	0.51688	0.52057	0.52427	0.52798	0.53171	62
28	0.53171	0.53545	0.53920	0.54296	0.54674	0.55051	0.55431	61
29	0.55431	0.55812	0.56194	0.56577	0.56962	0.57348	0.57735	60
30	0.57735	0.58124	0.58513	0.58905	0.59297	0.59691	0.60086	59
31	0.60086	0.60483	0.60881	0.61280	0.61681	0.62083	0.62487	58
32	0.62487	0.62892	0.63299	0.63707	0.64117	0.64528	0.64941	57
33	0.64941	0.65355	0.65771	0.66189	0.66608	0.67028	0.67451	56
34	0.67451	0.67875	0.68301	0.68728	0.69157	0.69588	0.70021	55
35	0.70021	0.70455	0.70891	0.71329	0.71769	0.72211	0.72654	54
36	0.72654	0.73100	0.73547	0.73996	0.74447	0.74900	0.75355	53
37	0.75355	0.75812	0.76272	0.76733	0.77196	0.77661	0.78129	52
38	0.78129	0.78598	0.79070	0.79544	0.80020	0.80498	0.80978	51
39	0.80978	0.81461	0.81946	0.82434	0.82923	0.83415	0.83910	50
40	0.83910	0.84407	0.84906	0.85408	0.85912	0.86419	0.86929	49
41	0.86929	0.87441	0.87955	0.88473	0.88992	0.89515	0.90040	48
42	0.90040	0.90569	0.91099	0.91633	0.92170	0.92709	0.93252	47
43	0.93252	0.93797	0.94345	0.94896	0.95451	0.96008	0.96569	46
44	0.96569	0.97133	0.97700	0.98270	0.98843	0.99420	1.00000	45
Tangents	60'	50'	40'	30'	20'	10'	0'	Degrees
	Cotangents							

NATURAL TRIGONOMETRIC FUNCTIONS

Degrees	Cotangents							Tangents
	0'	10'	20'	30'	40'	50'	60'	
0	∞	343.77371	171.88540	111.58865	85.93979	68.75009	57.28996	89
1	57.28996	49.10388	42.96408	38.18846	34.36777	31.24158	28.63625	88
2	28.63625	26.43160	24.54176	22.90377	21.47010	20.20555	19.08114	87
3	19.08114	18.07498	17.16934	16.34986	15.60478	14.92142	14.30067	86
4	14.30067	13.72674	13.19688	12.70621	12.25051	11.82617	11.43005	85
5	11.43005	11.05913	10.71191	10.38540	10.07803	9.78817	9.51436	84
6	9.51436	9.25530	9.00983	8.77689	8.55555	8.34196	8.14435	83
7	8.14435	7.95302	7.77035	7.59575	7.42871	7.26873	7.11537	82
8	7.11537	6.96823	6.82694	6.69116	6.56055	6.43481	6.31375	81
9	6.31375	6.19703	6.08444	5.97576	5.87080	5.76937	5.67128	80
10	5.67128	5.57638	5.48451	5.39552	5.30928	5.22566	5.14455	79
11	5.14455	5.06584	4.98940	4.91516	4.84300	4.77286	4.70463	78
12	4.70463	4.63825	4.57363	4.51071	4.44942	4.38969	4.33148	77
13	4.33148	4.27171	4.21933	4.16530	4.11256	4.06107	4.01078	76
14	4.01078	3.96165	3.91364	3.86671	3.82083	3.77595	3.73205	75
15	3.73205	3.68909	3.64705	3.60588	3.56557	3.52609	3.48741	74
16	3.48741	3.44951	3.41236	3.37591	3.34023	3.30521	3.27085	73
17	3.27085	3.23714	3.20406	3.17159	3.13972	3.10842	3.07768	72
18	3.07768	3.04749	3.01783	2.98869	2.96004	2.93189	2.90421	71
19	2.90421	2.87700	2.85023	2.82391	2.79802	2.77254	2.74748	70
20	2.74748	2.72281	2.69853	2.67462	2.65109	2.62791	2.60509	69
21	2.60509	2.58261	2.56046	2.53865	2.51715	2.49597	2.47509	68
22	2.47509	2.45451	2.43422	2.41421	2.39449	2.37504	2.35585	67
23	2.35585	2.33693	2.31826	2.29984	2.28167	2.26374	2.24604	66
24	2.24604	2.22857	2.21132	2.19430	2.17749	2.16090	2.14451	65
25	2.14451	2.12832	2.11233	2.09654	2.08094	2.06553	2.05030	64
26	2.05030	2.03526	2.02039	2.00569	1.99116	1.97680	1.96261	63
27	1.96261	1.94858	1.93470	1.92098	1.90741	1.89400	1.88073	62
28	1.88073	1.86760	1.85462	1.84177	1.82907	1.81649	1.80405	61
29	1.80405	1.79174	1.77955	1.76749	1.75556	1.74375	1.73205	60
30	1.73205	1.72047	1.70901	1.69766	1.68643	1.67530	1.66428	59
31	1.66428	1.65337	1.64256	1.63185	1.62125	1.61074	1.60033	58
32	1.60033	1.59002	1.57981	1.56969	1.55966	1.54972	1.53987	57
33	1.53987	1.53010	1.52043	1.51084	1.50133	1.49190	1.48256	56
34	1.48256	1.47330	1.46411	1.45501	1.44598	1.43703	1.42815	55
35	1.42815	1.41934	1.41061	1.40195	1.39336	1.38484	1.37638	54
36	1.37638	1.36800	1.35968	1.35142	1.34323	1.33511	1.32704	53
37	1.32704	1.31904	1.31110	1.30324	1.29541	1.28764	1.27994	52
38	1.27994	1.27230	1.26471	1.25717	1.24969	1.24227	1.23490	51
39	1.23490	1.22758	1.22031	1.21310	1.20593	1.19882	1.19175	50
40	1.19175	1.18474	1.17777	1.17085	1.16398	1.15715	1.15037	49
41	1.15037	1.14363	1.13694	1.13029	1.12369	1.11713	1.11061	48
42	1.11061	1.10414	1.09770	1.09131	1.08496	1.07864	1.07237	47
43	1.07237	1.06613	1.05994	1.05378	1.04766	1.04158	1.03553	46
44	1.03553	1.02952	1.02355	1.01761	1.01170	1.00583	1.00000	45
Cotangents	60'	50'	40'	30'	20'	10'	0'	Degrees
	Tangents							



## INDEX

- Acceleration, 100
  - angular, 114
  - of gravity, 101
- Angle of Repose, 83
- Angular velocity, 112
  
- Beam reactions, 22
- Block and tackle, 32
  
- Centroids, 85
  - of areas, 85
  - of circles, 88
  - of semicircles, 88
  - of triangles, 87
- Chain hoist, 36
- Components, 3
- Concurrent forces, 14
  - resultant of, 8
- Cone pulleys, 61
- Couples, 9
- Curvilinear motion, 109
  
- Differential pulley, 36
  
- Efficiency, 57
  - of screw jack, 57
- Energy, 119
  - kinetic, 119
  - potential, 119
- Equilibrium, 14
  
- Forces, composition of, 2, 8
  - concurrent, 14
  - moment of, 9
  - nonconcurrent, 39
  - resolution of, 6
- Friction, coefficient of, 76
  - kinetic, 76
  - limiting, 77
  - static, 76
  
- Gear trains, 64
- Gears, bevel, 66
  - idler, 72
  - spur, 64
- Gravity, acceleration of, 100
- Gyration, radius of, 95
  
- Horsepower, 118
  
- Kinetic energy, 119
- Kinetic friction, 76
  
- Lead of screws, 55
- Lead screws, 59
- Levers, 28
- Linear velocity, 99
  
- Mechanical advantage of levers, 31
- Moment of force, 9
- Moment of inertia, 91
  - of circles, 92
    - polar, 96
  - of rectangles, 91
  - of triangles, 91
- Motion, curvilinear, 109
  - rectilinear, 99
  
- Nonconcurrent, 39
  
- Parallel axis theorem, 92
- Parallel forces, resultant of, 18
- Pinion gear, 64
- Pitch diameter, 64
- Pitch of threads, 54
- Potential energy, 119
- Power, 118
- Pulleys, 59
  - cone, 61
  - stepped, 61
  
- Rack, 67
- Radius of gyration, 95

Reactions, of beams, 22  
normal, 76

Rectilinear motion, 99

Resolution of forces, 6

Resultant, 3

· of concurrent forces, 8

· of parallel forces, 18

Rotation, 112

Screw jack, 55

efficiency of, 87

Screw threads, 54

Spur gears, 64

· Static friction, 76  
Stepped pulleys, 81

Threads, pitch of, 54

Trusses, 46

· Vectors, 2

· Velocity, angular, 112

· linear, 99

Work, 117

Worm, 57

Worm wheel, 57













