

TIGHT BINDING BOOK

UNIVERSAL
LIBRARY

OU 164109

UNIVERSAL
LIBRARY

OUP-787-13-b-75-10,000.

OSMANIA UNIVERSITY LIBRARY

Call No. 535.82 Accession No. 24700

Author ^{A 42 m}
R. M. Allen

Title The microscope

This book should be returned on or before the date last marked below.

The
Microscope

In the manufacture of this book, the publishers have observed the recommendations of the War Production Board and any variation from previous printings of the same book is the result of this effort to conserve paper and other critical materials as an aid to the war effort.

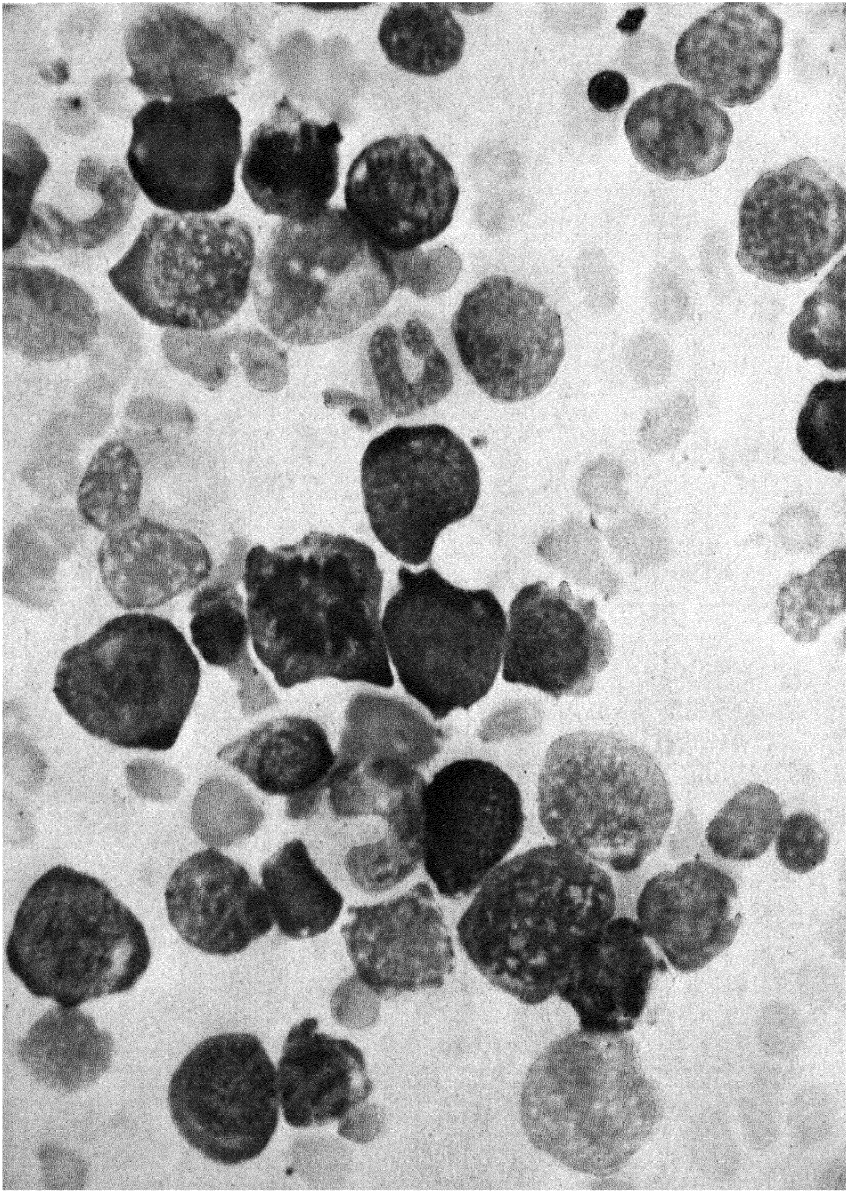

The slide of bone marrow from which this photomicrograph in color was taken, illustrates the appearance of a smear of living bone marrow from a case of pernicious anemia, when stained by Giemsa stain. The remarkable color differentiation is possible owing to slight variations in the chemical reactions of the nuclei and cytoplasm, to the stain.

THE
MICROSCOPE



R. M. ALLEN

Second Printing



LONDON
CHAPMAN & HALL, LTD.

11 HENRIETTA STREET, W.C. 2

COPYRIGHT, 1940, BY
D. VAN NOSTRAND COMPANY, INC.

All Rights Reserved

*This book or any parts thereof, may not
be reproduced in any form without
written permission from the publishers.*

First Published January 1940
Reprinted November 1941, February 1944

Printed in U. S. A.

Printing
F. E. GILSON CO.
BOSTON

Composition
TECHNICAL COMPOSITION CO.
BOSTON

Binding
STANHOPE BINDERY
BOSTON

PREFACE

Our debt to the microscope is tremendous; yet the list of books dealing with its use is relatively small. This then must be the justification for a new book that is devoted wholly to the theory and manipulation of an instrument in such common use.

There are many who wish a practical treatise on the microscope even though they have not had sufficient technical training to enable them to understand the advanced mathematics of optical science. This part of the subject has, therefore, been treated in the simplest possible manner with the omission of all but essential formulae. The book is, however, based on the best contributions of American and European manufacturers, and the methods and technique of mounting described represent actual practice originated and developed in the author's own laboratory.

No one book can, without being unduly extensive, treat the multifarious phases of micro-technique. This volume is no exception and a desire to keep the cost of the book at the lowest possible figure has limited the extent to which each field is presented. Those working in special fields can with profit refer to the specialized volumes that are listed in the bibliography and which treat individual subjects in which the microscope plays an important part. The book also includes a glossary which should be consulted when the meaning of words employed in the text is abstruse or not sufficiently clear.

It is the author's sincere hope that this book will supply information not available in any other single volume, that it will aid in improving technique for present users of the microscope, and that it will serve as a source of inspiration for others to adopt this fascinating work either as vocation or an avocation.

In explanation of the fact that the products of English manufacturers and of some well known European concerns, have not been given a place among the numerous illustrations of modern instruments and equipment, it must be stated that this is in no way a reflection on the quality of the apparatus produced by these con-

cerns. On the contrary most of them are entitled to rank with any of the makes described in the text. Space limitations, however, are confining and instruments illustrated are those mostly met with in the American market. It is to be regretted that English manufacturers, in particular, appear to make no effort to introduce their instruments in the United States, for some of their designs are very appealing to discriminating microscopists.

R. M. A.

November 1939

CONTENTS

CHAPTER	PAGE
1. HISTORICAL INTRODUCTION	1
Antiquity of the microscope — Simple lenses found in ruins of ancient cities — References to magnification in early literature — Evidence of the use of magnifying lens in early times — Advent of the compound microscope — Early forms — Pioneers in its development — The Jansens, Leeuwenhoek, Hooke and others — Their contributions — Advent of achromatic lenses — Their application to the microscope — Beginnings of commercial microscope manufacture — Development of modern form of the instrument — Various accessories and improved lenses — Abbe's contributions — Gradual application of the microscope to biological, medical and commercial fields — Recent trends in design and use.	
2. OPTICAL PRINCIPLES OF THE MICROSCOPE	15
Basis of magnification without lenses — Improvements by use of lenses — Refraction of light — Utilization of refraction in image formation by a lens — Laws relating to image formation — Various types of lenses — Real and virtual images — The part played by the eye in image formation and magnification — Magnification with simple magnifiers — Principles of the compound microscope — Aberrations in lenses and the methods of correcting for them — Achromatic and apochromatic objectives — The mechanical parts of the compound microscope — Standardization — Determining magnification of various combinations — Limit of magnification — Equivalent focus — Angular and numerical aperture — Depth of focus — Optical plane — Effect of coverglass thickness — Oculars, various types — Substage condensers, various forms, characteristics of — Their use with different lenses.	
3. MODERN INSTRUMENTS	65
Modern tendencies in design — Determining the age of an instrument — Models suited for various purposes — Advantages and limitations of each — School, laboratory and workroom models — Biological, medical and research models — Designs of various manufacturers — Reversed arm type — Chemical and petrographical microscopes — Metallurgical microscopes — Low power binocular microscopes — Microscopes and outfits for very special purposes — The slit ultra-microscope and ultra-violet microscope — Universal microscopes — Accessories — Objectives — Eyepieces — Condensers — Mechanical stages — Polarizing devices — Simple dissecting microscopes.	
4. ILLUMINATION	109
Importance of illumination in image formation — Light sources — Use of mirror — Critical illumination — How obtained — Abbe and Köhler methods — Particular advantages of each — Intensity of light required for various purposes — Highly corrected, centering and fine-focussing condensers — Illumination for opaque work — Vertical illumination — Complete illumination outfits for opaque work.	

CHAPTER	PAGE
5. TESTING OF MICROSCOPE OBJECTIVES	125
Need for tests on objectives — Defects affecting image formation — How they are determined — Damaged lenses — Nature of tests — Testing devices and their value — Apertometer — Abbe Test Plate — Effect of cover-glass thickness — Testing for correction of aberrations — Various test objects — Diatoms, disadvantages and limitations — Abbe's diffraction theory — Ruled gratings — Ideal objects for general test purposes — Testing for polarization in objectives.	
6. GETTING THE MOST OUT OF THE MICROSCOPE	140
Care and manipulation of the microscope — Development of an ideal technique — Use of oil immersion objectives — When to oil the condenser — Study of opaque and uncovered objects — Working conditions — The personal equation — Eyestrain — Working under various handicaps — Inclined tubes and angle eyepieces — Value of binocular eyepieces in reducing eyestrain — Eye shields — Handling microscopical problems — Drawing false conclusions — Apparatus and technique for special purposes — Measuring with the microscope — Counting methods — Marking fields for reference — Demonstration and comparison — Drawing, projecting and photography — Accentuating and suppressing contrast — Refractive index and contrast — Use of light filters — Rheinberg illumination — Optical sectioning vs. depth of focus — Magnification vs. resolution — Dark-field microscopy — Polarized light, its nature and uses — Miscellaneous equipment for very special purposes.	
7. PREPARATION OF MATERIAL FOR MICROSCOPICAL EXAMINATION	178
Basic principles of slide making — Necessary equipment — Implements — Mounting media — Chemicals, reagents, etc. — Glassware and miscellaneous equipment — Stains — Cleaning slides and covers — The technique of various mounting methods — Non-sectioning and sectioning objects — Delicate objects — Killing and fixing — Celloidin and paraffine embedding — Sectioning, freehand and microtome — Serial sections, fixing on slide, staining and mounting — Small delicate objects mounted whole — Finishing the slide, storing and indexing — Special mounting methods, dry mounting, box mounts, fluid mounts — Venice turpentine — Ultra-violet mounts — Sections of hard materials — Polishing and etching of metals — Formulæ.	
PLATES	230
BIBLIOGRAPHY	247
GLOSSARY	255
INDEX	276

TEXT FIGURES

FIGURE	PAGE
1. REPLICA OF LEEUWENHOEK'S MICROSCOPE	4
2. REPLICA OF ROBERT HOOKE'S MICROSCOPE	6
3. CHEVALIER'S MICROSCOPE OF 1851	9
4. ZENTMEYER'S AMERICAN CONTINENTAL MICROSCOPE OF 1880	11
5. SHARP IMAGE FORMATION THROUGH MINUTE HOLE	15
6. NON-SHARP IMAGE FORMATION THROUGH LARGE HOLE	16
7. IMAGE SHARPENED BY LENS	17
8. REFRACTION OF LIGHT	18
9. FOCUS OF LENS	19
10. FORMATION OF IMAGE	21
11. RELATION OF CONJUGATE FOCI	22
12. TYPES OF LENSES	25
13. CROSS-SECTION THROUGH THE HUMAN EYE	26
14. SIZE OF OBJECT AT VARYING DISTANCES	29
15A. TYPES OF SIMPLE MAGNIFIERS	31
15B. TYPES OF SIMPLE MAGNIFIERS	31
16. IMAGE FORMATION WITH MAGNIFIER	33
17. SCHEMATIC DIAGRAM OF COMPOUND MICROSCOPE	35
18. SPHERICAL ABERRATION	36
19. THREE LENS CORRECTION FOR SPHERICAL ABERRATION	37
20A. CHROMATIC ABERRATION IN A SIMPLE LENS	38
20B. OVER-CORRECTION IN A DOUBLET LENS	39
21. TYPICAL MICROSCOPE WITH PARTS NAMED	42
22. OBJECTIVES OF THE OLDER, EXTERNAL THREAD FORM IN CROSS-SECTION	50
23. OBJECTIVES OF THE MODERN INTERNAL BARREL CONSTRUCTION IN CROSS-SECTION	50
24. SPHERICAL ABERRATION DUE TO COVER GLASS	56
25. PATH OF LIGHT RAYS IN DRY AND IMMERSION OBJECTIVES	58
26. LONG AND SHORT MOUNT OBJECTIVES WITH LENS OF THE SAME POWER	59
27. HUYGENIAN AND RAMSDEN EYEPIECES IN CROSS-SECTION	61
28. PATH OF LIGHT RAYS IN A COMPOUND MICROSCOPE	63
29. SIMPLE LABORATORY OR STUDENT'S MICROSCOPE	69
30. MEDICAL OR BIOLOGICAL MICROSCOPE	71
31. BAUSCH AND LOMB RESEARCH MICROSCOPE	73
32. SPENCER RESEARCH MICROSCOPE	74
33. LEITZ RESEARCH MICROSCOPE	75
34. ZEISS RESEARCH MICROSCOPE	76
35. BAUSCH AND LOMB REVERSED TYPE MICROSCOPE	77
36. SPENCER REVERSED TYPE MICROSCOPE	78
37. LEITZ PETROGRAPHIC MICROSCOPE	81
38. BAUSCH AND LOMB PETROGRAPHIC MICROSCOPE	82
39. PATH OF LIGHT RAYS IN VERTICAL ILLUMINATOR	84
40. SIMPLE METALLURGICAL MICROSCOPE	85
41. METALLURGICAL MICROSCOPE — INVERTED TYPE	86
42. GREENOUGH BINOCULAR MICROSCOPE	87
43. BRINELL MICROSCOPE	88
44. SLIT ULTRA-MICROSCOPE	89
44A. CROSS-SECTION DIAGRAM OF SLIT ULTRA-MICROSCOPE	90
45. LEITZ "PANPHOT" UNIVERSAL METALLOGRAPHIC MICROSCOPE	92
46. ZEISS "ULTRAPHOT" UNIVERSAL MICROSCOPE COMBINED WITH CAMERA	93
47. TRIPLE NOSEPIECE WITH LARGE GUARD	95

FIGURE	PAGE
48. SLIDING OBJECTIVE CHANGER	96
49. BINOCULAR EYEPIECE	97
50. DEMONSTRATION EYEPIECE	98
51. COMPARISON EYEPIECE	99
52. INCLINED MONOCULAR EYEPIECE	100
53. DIAGRAM OF THE PATH OF LIGHT RAYS IN A CARDIROID TYPE DARK FIELD	101
54. ZEISS PANCRATIC CONDENSER	102
55. SCHEMATIC OF MICROSCOPE WITH PANCRATIC CONDENSER	103
56. POLARIZER AND CAP ANALYZER	106
57. ATTACHABLE MECHANICAL STAGE	106
58. LEITZ MICRO-MANIPULATOR WITH SPECIAL MICROSCOPE	107
59. CRITICAL ILLUMINATION WITH TRANSMITTED LIGHT	112
60. ILLUMINATION BY BULL'S-EYE CONDENSER	114
61. PROPER AND IMPROPER AXIAL ILLUMINATION	115
62. PRINCIPLE OF KÖHLER METHOD OF ILLUMINATION	118
63. UNSATISFACTORY NATURE OF DAYLIGHT ILLUMINATION	118
64. BULL'S-EYE CONDENSER	123
65. ABBE APERTOMETER	128
66. USE OF A DECENTERED REDUCED CONE OF ILLUMINATION	134
67. APPEARANCE OF THE MARKINGS OF PLEUROSIGMA ANGULATUM	135
68. USE OF INCLINED EYEPIECE	150
69. EYE SHIELD	151
70. MEASURING THE SIZE OF AN OBJECT BY PROPORTION OF FIELD	157
71. OBJECT MARKER	161
72. RELATION BETWEEN LIGHT AND DARK FIELD ILLUMINATION	169
73. APPLICATION OF DARK FIELD PRINCIPLE	170
74. DIAPHRAGM STOPS FOR DARK FIELD	171
75. ORDINARY AND POLARIZED LIGHT	172
76. COVER GLASS GAUGE	182
77. A NEST OF SECTION LIFTERS	183
78. COVER GLASS FORCEPS	183
79. BALSAM BOTTLE	186
80. HAND MICROTOME AND RAZOR	187
81. AUTOMATIC SLIDING MICROTOME	204
82. ROTARY MICROTOME	205

PLATES

PLATE	PAGE
I. DIATOM PLEUROSIGMA ANGULATUM, $\times 1,500$	230
II. FIBROUS TALC, $\times 500$	231
III. LIGNITE COAL, $\times 25$	232
IV. DIATOM TRICERATIUM FAVUS, $\times 500$	233
V. DIATOM TRICERATIUM, $\times 500$	234
VI. DIATOM TRICERATIUM, $\times 1,000$	235
VII. DIATOM TRICERATIUM, $\times 1,000$	236
VIII. THE VALVE WALL OF TRICERATIUM, $\times 2,500$	237
IX. "CEMENTSTEIN," DIATOM WALL, $\times 3,000$	238
X. DIATOM NAVICULA LYRA, $\times 1,000$	239
XI. DIATOM NAVICULA LYRA, $\times 1,000$	240
XII. RED CORAL POLYP BY DARK FIELD, $\times 15$	241
XIII. SPIRULINA JENNIFERII BY DARK FIELD, $\times 500$	242
XIV. SPIROCHAETE OF RELAPSING FEVER BY DARK FIELD, $\times 1,500$	243
XV. COLLOIDAL LEAD, BY DARK FIELD, $\times 1,500$	244
XVI. GARDEN SPIDER, $\times 2$	245
XVII. PROBOSCIS OF HOUSEFLY, $\times 75$	246

Chapter 1

THE HISTORY OF THE MICROSCOPE

The origins of most outstanding scientific instruments, and the names of those responsible for them, are matters of historical record. That of the microscope, however, remains a mystery. No one knows who first used a lens to magnify minute objects. Some day, perhaps, some gratified archaeologist may unearth a clay tablet that will tell the story; just now all we can say is that, like Topsy, the microscope seem never to have been born at all, but "just grewed."

The existence of magnifying lenses in early times may be circumstantially inferred; definite references to such lenses appear in the literature of some two thousand years ago. Seneca writes, "However small and obscure the writing may be, it appears larger and clearer when viewed through a globule of glass filled with water." Similar globules of glass are referred to by Aristophanes as being sold in Athens, under the name of "burning spheres."

There have been unearthed from the ruins of Nineveh, Pompeii, and Herculaneum, lenses of quartz and glass, undoubtedly made for magnification. Nero was said to possess a "gazing crystal" made from amethystine quartz. It was probably only a weak lens such as is now used for certain types of eyeglasses, but its mention indicates that something of the science of optics was known at that time. This is further confirmed by Ptolemy, who wrote a book on optics, discussing the phenomenon of refraction when light passes at angles from air into glass or water.

It is well known that the ancients understood the art of glass making in a crude way; the writer possesses a specimen of glass made in Syria prior to the Christian era. Undoubtedly such glass was first produced for making ornaments and jewels, as substitutes for natural

stones; of course the then common practice of grinding gems lenticular in shape must have inevitably resulted in the discovery that such convex forms possess the property of magnification.

It is therefore fairly safe to assume that the microscope originated from some such humble circumstance; how long ago we cannot know.

There is evidence to indicate that magnifying lenses were very early put to practical use. Most of this evidence is in the form of minute objects — carvings, engravings, etc. — which could not have been produced without some form of magnifier, unless we assume that the ancients had miraculous eyesight not transmitted to our generation.

Despite the ancient origin of lenses, little advance in development or improvement occurred until the last few centuries, although they had begun to attract scientific attention considerably earlier. For instance, Roger Bacon, who died about 1294, wrote in his *Opus Majus*:

“ Greater things than these may be performed by refracted vision. For it is easy to understand by the canons above mentioned that the greatest objects may appear exceedingly small, and the contrary, also that the most remote objects may appear just at hand, and the converse; for we can give such figures to transparent bodies, and dispose them in such order with respect to the eye and the objects, that the rays shall be refracted and bent towards any place we please, so that we shall see the object near at hand or at any distance under any angle we please. And thus from an incredible distance we may read the smallest letters, and may number the smallest particles of dust and sand, by reason of the greatness of the angle under which we see them.”

Probably the increasing use of spectacles in the sixteenth century furnished the impetus to developments of the microscope as well as of the telescope. Probably, too, the latter came first, for the first mention of what is now known as the compound microscope concerns one far more like a telescope than a microscope. It was six feet long with a one-inch barrel and lenses at each end!

Galileo's first biographer wrongly attributed the invention of the microscope to him, so concurrently were the two instruments brought

forward.* It is probable that Galileo heard of one of the instruments made by either Jansen, Fontana, or Drebell and so modified one of his telescopes that it would function as a microscope. Later on, in 1624, he had an opportunity to examine one of Drebell's microscopes in Rome. Thereupon he promptly devised some ingenious improvements, which he incorporated in an instrument of his own.

Whether or not the Jansens (father and son) were the actual inventors of the compound microscope, we cannot be sure. It seems that at least they should be credited with putting its manufacture on a commercial scale, for they were making instruments prior to 1600, and no one else claims so early a date.

Cornelius Drebell's† first microscope was made by the Jansens; whether it was after his own design or theirs is not known. Still a third scientist, Fontana, refers to microscopes he had made in 1618, apparently without previous knowledge of any others. Thus we see that almost simultaneously, between the years 1590 and 1620, interest in both the compound microscope and the telescope developed in several different quarters.

Although scientific accuracy demands that we class the instruments produced by Jansen and his contemporaries as compound microscopes (as they consisted of two magnifying components, an objective and eye lens), we have practically to stop there, for in no other respect can they be said to resemble what we now consider a microscope. Their magnification was apparently small and they were considered rather as scientific toys than as instruments for discovering secrets of nature. There seem to have been no scientific discoveries made with these instruments, and the names of Jansen and his contemporary microscope manufacturers have all but vanished.

In their stead have arisen two other names, familiar not only to microscopists but even to the world at large: Anthony van Leeuwenhoek and Robert Hooke. One Dutch, the other English, they were contemporaries who took up the microscope nearly half a century after the advent of the compound microscope.

*Galileo did not, as is commonly believed, invent the telescope; he merely became the first to popularize its use. The credit for the invention of the telescope and the compound microscope apparently should go to the Jansens.

†He was important in popularizing the microscope in England and other European countries.

Both these men apparently sensed the deficiencies of the microscopes then in use. By different paths both reached almost identical results, introducing for the first time what may rightly be called high-power microscopy. The powers were, it is true, not high powers as we now know them, but they were adequate to discern some

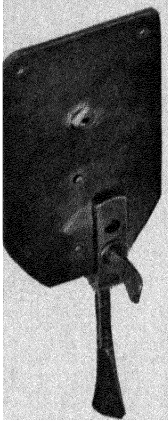

FIG. 1. Replica of Leeuwenhoek's Microscope.

(Courtesy of Bausch & Lomb Optical Co.)

minutiae not previously even surmised.

The secret lay in the use of lenses of very short focus, ranging from extremely double-convex to spherical in form.

First thought might suggest that Leeuwenhoek had taken a backward step, for he abandoned the compound microscope for a single lens — of only about the size of a pinhead, and even smaller! In his lifetime he made hundreds of microscopes, the lenses of which he ground himself, carefully guarding the secret of his methods. Each lens was mounted in a platelike holder, for he believed in having a microscope of suitable magnifying power for every object. A replica of one of his instruments is shown in Figure 1.

It is not primarily for his instruments that Leeuwenhoek is noted, although his lenses may be said to be the forerunners of the front lenses of modern high-power oil-immersion objectives. Rather it is for the wealth of discoveries which he made. He may well be called the father of biology and bacteriology. He first described the existence of infusoria, bacteria, yeast cells, the varieties of red corpuscles in the blood of man, animals, frogs, and fish, and many other histological structures, plant and animal. Microscopy was to him a real hobby, for he apparently had no definite scientific basis for his methods of study.

Working entirely independently of Leeuwenhoek, Dr. Robert Hooke in England also turned his attention to small spherical lenses as the key to higher powers. His lenses, however, were not ground as were Leeuwenhoek's but were made by the simple expedient of fusing the end of a minute glass rod in a flame. Molten glass obeys the same law as all fluids and tends to assume a spherical shape. Moreover, melted glass cools with a high surface polish, equal to that obtained by grinding and polishing.

Hooke went beyond Leeuwenhoek in that he soon abandoned his simple spherical lenses for a compound microscope, using a high-power lens as the objective. It is questionable, however, whether he saw more with his compound microscopes than the Dutchman did with his single lenses, as absence of any correction for chromatic and spherical aberrations precluded the possibility of good resolution at high magnification.

The advantage of Hooke's microscopes lay in the greater ease with which the compound instrument could be used. It was necessary to place Leeuwenhoek's lenses very close to the eye and squint through them in a manner impossible, apparently, to all except Leeuwenhoek himself. At any rate, he saw things which no one else was able to see, although, as later researches have demonstrated, with great accuracy in every case.

Hooke did a great deal of microscopical investigating, the results of which were transmitted to posterity through his *Micrographia Illustrata*, published in 1667. It is rather through the book than through any notable contribution he made to the instrument itself that he is best known to microscopists. He, like Leeuwenhoek, was essentially an amateur microscopist, indulging a hobby.

Besides Robert Hooke's name, those of Eustachio Divini and Philip Bonnani are associated with the development of the compound microscope from 1660 to 1720. Divini's microscope, as described before the Royal Society of England in 1668, provides interesting contrast to modern instruments. It was constructed rather like present-day collapsible telescopes, with four sliding sleeves for obtaining various degrees of magnification. These sleeves were several inches in diameter; when closed to the shortest length they were about sixteen inches long; extended, they measured several feet. A single-focus, double-convex lens served as an objective; the eyepiece was formed of two plano-convex lenses mounted with the convex sides toward each other, as in the positive, or Ramsden, type of eyepiece. These eye lenses were two inches in diameter. The magnification obtained ranged from 41 times when completely collapsed, through 90 \times , 111 \times and 143 \times as the successive tubes were extended. (It would appear from this that the objective lens was approximately of one-inch focus.)

As one contrasts this instrument with the smaller form designed by Hooke, the contribution of the latter in adopting short-focus lenses, with their correspondingly higher initial magnification, as object glasses, seems quite material.

It is not surprising that at about this same time the microscope should have intrigued a physicist, Sir Isaac Newton. Having discovered and stated his theory of light and the separation of colors, he

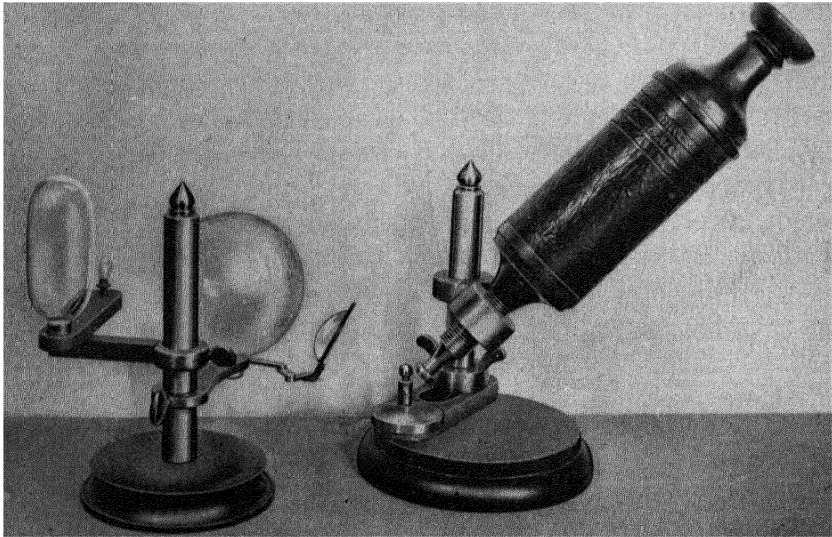

FIG. 2. Replica of Robert Hooke's Microscope

(Courtesy of Bausch and Lomb Optical Co.)

was in a position to appreciate the aberrations of light as it passed through the various lenses of the microscope. To secure a magnified image and obviate a portion of the dispersion, he suggested, in a communication to the Royal Society in 1672, a design for a microscope using a concave spherical reflector in combination with an eyepiece which magnified the reflected image. Although this form of instrument was tested by several workers and admittedly worked after a fashion, it never became very popular, for obvious reasons. It is interesting, however, as marking the first attempt to eliminate chromatic and spherical aberrations from the microscopical image. Early

recognition of the limitation placed upon magnification by these aberrations and of the apparent impossibility of eliminating them had a somewhat depressing effect on further development of the compound microscope. Many of the foremost opticians believed that the compound microscope could never rival the single short-focus type in its relative freedom from color.

Thus, except for the introduction of the smaller-sized microscope, very little improvement occurred between 1720 and about 1800. Yet, during this entire period, the science of microscopy was growing. Many discoveries made with the instrument were given to the world through scientific societies. Improvements of a minor nature were continually being made, such as means for changing objectives and eyepieces, means for holding and illuminating specimens, etc. One important device was Lieberkuhn's illuminator for opaque specimens, originally designed about 1740 for use with a simple microscope, but subsequently perfected, in the form now bearing his name, for application to the compound microscope. In this illuminator the objective is mounted in the center of a concave-spherical metal reflector so that light sent from below the stage is reflected by it, back upon the object. Lieberkuhn's invention of the solar microscope, at about this same time, was hailed as remarkable by the microscopists of his day. It was merely a microscope arranged to project an image on a screen in a darkened room, using sunlight as the source of illumination. Perhaps we should consider this the beginning of the modern stereopticon rather than as an improvement in the microscope, but it appears that the intense light did allow the use of fairly high powers.

Euler's discovery, in 1776, of the way to make achromatic lenses, although it bore immediate fruit in the telescope, did not seem to help the microscope to the same extent when it came to high-power magnification. Apparently the great amount of spherical aberration in lenses of high angular aperture was not yet fully appreciated, nor were means known of effecting a combined correction for chromatic and spherical aberrations.

This problem attracted many of the most brilliant minds of the period. Fraunhofer, Wollaston, Amici, Fresnel, Brewster, Herschel, Chevalier, and others were associated, at one time or another, with its solution. Although each of these contributed something of value

to the cause, it was not until nearly fifty years after Euler's discovery that the first real advance was made. The credit goes to a Frenchman, Selligie, who, in collaboration with Chevalier, in 1823 designed an objective composed of four achromatic components, each of which was a doublet.

Other workers in England succeeded at about the same time in producing lenses of marked superiority. Thereafter the advance in the optics of the microscope was rapid. One notable improvement was made in 1829 when Lister, in England, first joined the achromatizing doublets together with Canada balsam, thus increasing the effective light by almost one hundred per cent.

With the advent of achromatic lenses microscopy became an important science. The medical profession sensed the microscope's value; scientists and amateurs alike took it up enthusiastically, quickly creating sufficient demand to justify manufacturing it on a commercial scale.

Thus we find, in the period from 1835 to 1875, numerous optical firms in England, continental Europe, and America, turning out microscopes of the highest quality. Many of these, or their successors, are still in the same business, which fact naturally speaks well for their product. Others, in spite of high quality instruments and lenses, centered in single individuals and so fell with the passing of the controlling genius. At any rate, the following names have, at one time or another, achieved prominence: Ross, Powell and Leland, Baker, Beck and Watsons in England; Hartnack, Zeiss, Nacet, Chevalier, Leitz and others in Europe and Wales, Tolles, Zentmayer, Gundlach, Spencer, and Bausch and Lomb in America.

The mechanical ingenuity evidenced by the designs of some instruments made during this formative period is remarkable. Figure 3, from Brocklesby's *Views of the Microscopic World* (published in New York in 1851), shows one of Chevalier's models. It must have been rather tiresome to use such an instrument for any length of time, yet, if one is to judge by the clearness with which many details are drawn in Brocklesby's book, the lenses, at least, must have functioned fairly well.

Sentiment gradually crystallized in favor of certain conventional designs which were subsequently adopted by all manufacturers.

Among these were the inclination joint by means of which the instrument could be set at any convenient angle, coarse and fine adjustments, sliding draw tube, and means for changing objectives and eyepieces. A stand of the 1880 period, incorporating these changes,

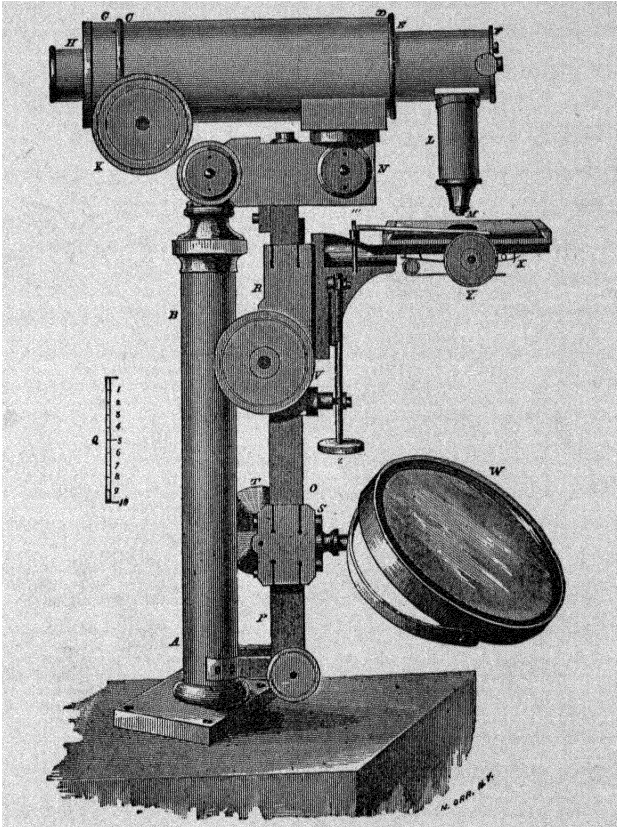

FIG. 3. Chevalier's Microscope of 1851

is shown in Figure 4, taken from the 4th edition of J. H. Wythe's book "The Microscopist." This stand also shows the use of the binocular tube employed with the Wenham prism which was very popular about this time on the more elaborate models.

On the optical side, probably the most marked new development characteristic of this period was the introduction of immersion lenses for high magnifications. Credit for the idea goes to Amici, who

introduced a water-immersion lens in 1840. Hartnack made another in 1855; this was followed by a glycerine-immersion objective by Gundlach in 1867, and by other types using various oils by Amici in 1869. A moot question among microscopists at the time was whether the use of a medium with higher refractive index than air was any improvement. Some argued that a dry lens which would pick up the theoretical maximum angle of 180° was as good as an immersion lens, for it would get all the light there was. The underlying theory of microscopical resolution was, of course, not then recognized, and it remained for other improvements to be introduced before the advantages of immersion lenses could be appreciated. One of these was the substage illuminating apparatus.

The gradual use of high powers with transparent preparations illuminated from beneath the stage necessitated some form of lens for condensing more light on the object. At first this was a simple form, but Ernst Abbe in 1872 produced his two-lens condenser, which gave for the first time an illuminating aperture exceeding 1.00 N.A.* by immersion contact with the bottom of the object slide.

In the same year the Zeiss Company put out the first immersion objective computed by Abbe's new system of lens formulation, destined to be the basis of an entirely new science in the production of microscope optical parts.

All objectives manufactured prior to this time had been arrived at solely by empirical methods, cut and try, trial and error. Designs that were faulty were simply eliminated; those which gave good results were adopted.

Abbe — by inclination and training a physicist and mathematician rather than an optician — on entering the Zeiss firm interjected a new approach to lens making. He reasoned that the proper method of approach to the problem was first to calculate on paper the ideal form which the lens components should possess to overcome the various aberrations present in the then known kinds of glass, namely, crown and flint. He argued that if one solved the questions of dimensions, surface curvatures, glass, and all other requirements which the individual lenses should meet, instructions could then be issued to the lens makers which, if followed accurately, should produce a fin-

*See description of Numerical Aperture, p. 52.

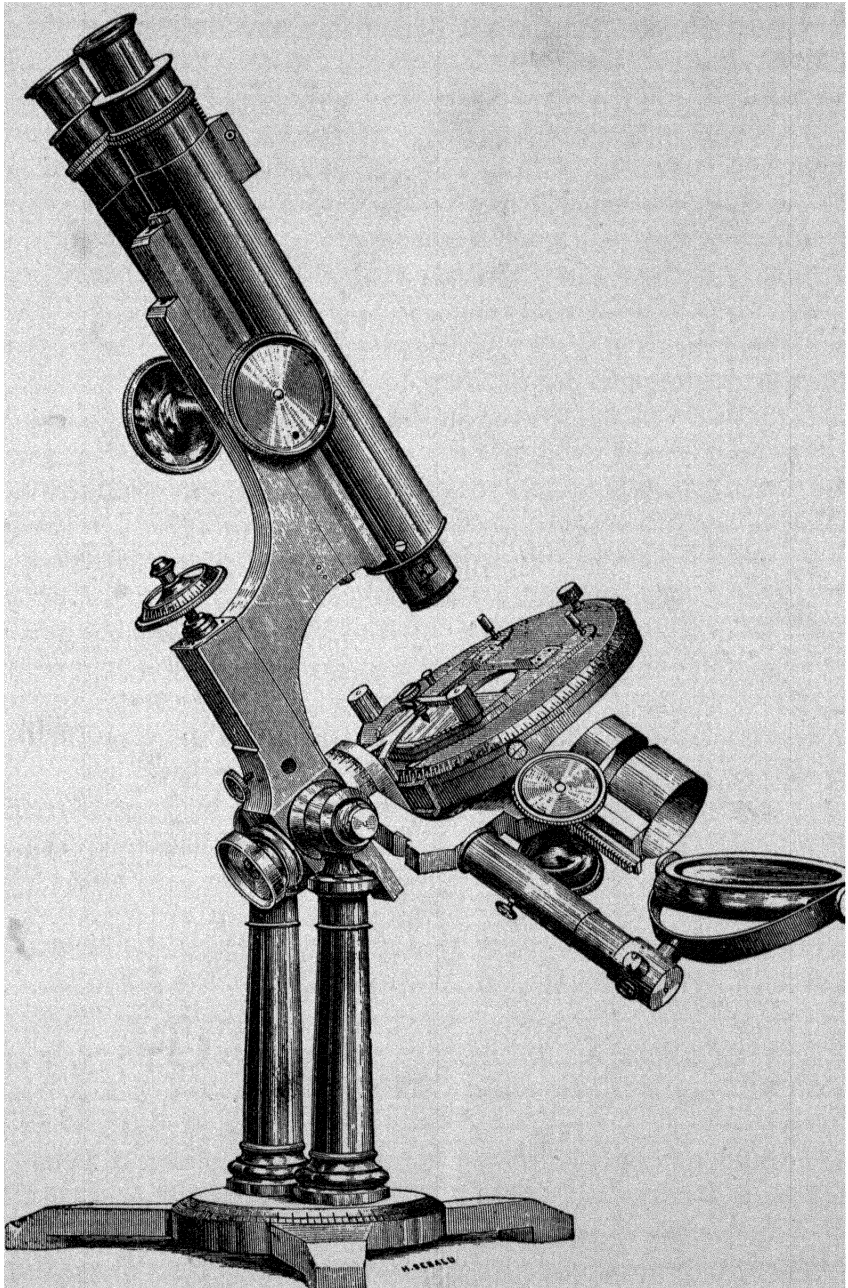

FIG. 4. Zentmeyer's American Continental Microscope of 1880

ished product possessing the characteristics previously determined. Because Abbe could calculate correctly, the idea worked. Today, this is the only approach to the problem of producing a new lens.

In 1878, Stevenson and Abbe put out the first "homogeneous" immersion lens. It differed from the immersion lenses then in use in that it was calculated to employ an immersion fluid as near as possible in refractive index and dispersion to the glass itself. The immersion fluid was a specially thickened cedar oil.

The Abbe condenser and the quality images produced by the immersion lenses, combined with an innate desire of microscopists to reach the highest possible magnification, were responsible, about this time, for many manufacturers going off on what later proved to be a tangent. They argued that if a $\frac{1}{1\frac{1}{2}}''$ lens gave an initial magnification of 120 times, a $\frac{1}{2\frac{1}{5}}''$, would give twice that, a $\frac{1}{5\frac{1}{0}}''$ four times and a $\frac{1}{7\frac{1}{5}}''$ over six times. Thus an initial magnification of 750x could be secured with the later lens, before being further magnified by the eyepiece! Many lenses of these short focal lengths were manufactured and eagerly sought after by amateurs who were able to pay the high price they commanded. Today these lenses are but museum curiosities, thanks to Abbe, who showed mathematically the difference between mere magnification and resolution, and that nothing was gained by using such short-focus lenses.

Abbe proved to be the world's greatest genius so far as scientific contributions to optics were concerned. In 1886 he brought out the apochromatic series of objectives and compensating eyepieces. The development of modern optical glass is largely due to his work, for he first showed what could be accomplished, provided certain glasses were available, and then collaborated with the Schott Glass Works to produce them. Many accessories and optical instruments bear his name, among them the Abbe Apertometer, Abbe Test Plate, Abbe Drawing Apparatus, the Abbe Comparator, and the Abbe Refractometer.

The decade from 1870 to 1880 witnessed the birth of many amateur microscopical societies in America. They had already become popular in England. Enthusiasm ran high. They issued journals and other publications as outlets for new information concerning things microscopic. We owe these societies much gratitude, for they pre-

ceded the general introduction of the microscope into the classroom, and they were the principal sources of information and training in the use of the instrument. Most of the books on microscopy published during this period came from the pens of persons connected with the societies. It was but natural that, as amateur enthusiasm waned, many of these organizations died, but the larger and more stable are still flourishing.

The history of any development, in any field, tends to run in cycles; each period of advance is followed by one of recession, or at least of inactivity, before the next spurt forward. The microscope and microscopy have proved no exception; several such cycles can be counted in their history. They have not indeed gone backward, even briefly, but there have been periods when apparently development was at a standstill. Such a quiescent time occurred during the latter years of the nineteenth century and the first decade of the twentieth.

No new or startling innovations appeared in the design of instruments; the optics remained practically stationary. The only marked progress was in the gradual introduction of the microscope into the schools, especially for the study of biology. It was, of course, already strongly entrenched in the medical field.

While there was a tendency toward an introduction of the microscope into commercial fields just before 1914, it was by no means general.

During the World War, the microscope's forward march was started once more, and it has been keeping the pace set for it ever since. Suddenly the commercial world became microscope-conscious, with the realization that it could solve many problems induced by new standards, new ways of living, and new materials of construction. Better metals, better alloys, better artificial products were produced through application of the microscope. Better control of output was secured, higher standards of quality were maintained, more minute flaws were detected through its use. With the recognition of these facts, demand for the instrument and associated equipment rose to a point where the manufacture of microscopes once more became profitable. This in turn has hastened the production of new designs, new apparatus to meet specific needs, and equipment capable of turning out a maximum of work in a minimum of time. It is safe to say that

more new designs, of more radical types, have been put out in the last ten years than in the previous half century. As to the optics, while the standards of commercial quality have been raised materially, actually there has been no fundamental improvement in performance since the apochromatic series of objectives was introduced in 1886 (with the exception of a practical utilization of shorter wave lengths, which Abbe showed would increase resolution).

Such, to date, is the history of the microscope.

Chapter 2

OPTICAL PRINCIPLES OF THE MICROSCOPE

The microscope is essentially an instrument for making minute objects appear larger than they actually are, or, to use the term ordinarily employed, "magnify them." It is, therefore, apparent that in discussing the optical principles utilized to accomplish this, the first step must be to outline what is involved in magnification.

Obviously no change takes place in the object itself. Therefore magnification must be effected by the production of an enlarged image of the object through means conforming to the operation of physical laws governing the behavior of light. Such an image can be produced only by light emanating from, although not necessarily originating in the object. It is possible to visualize the principle of image formation by a very simple illustration.

Image Formation

Suppose we have a box entirely closed to the entrance of light except for a minute hole on one side. When a brightly illuminated object is situated outside the box, in front of the hole, light from

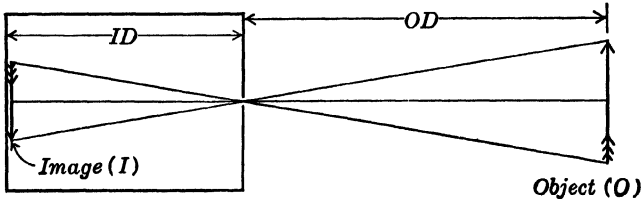

FIG. 5. Sharp Image Formation through Minute Hole

every portion of the object enters the box through the hole and, as all the light rays travel in a straight line, an inverted image of the object will appear in the box, on the side opposite the hole. This is illustrated in Figure 5.

Assuming an infinitely small hole, the image would be perfectly sharp* regardless of the size of the box or the distance of the object from the hole. Variations in these dimensions affect only the relation between the size of the object and the size of the image. Three different conditions are possible. When the distance from the hole to the image is less than that from the hole to the object, the image is smaller than the object. We then say it is reduced, or *minified*. When the two distances are equal, the image size is identical with that of the object. When the object is closer to the hole than the image, the latter is enlarged, or *magnified*. In every case the ratio between the size of the object and its image is the same as that between the object distance and the image distance from the hole.

Expressed mathematically it is

$$I : O :: DI : DO, \quad \text{or} \quad \frac{I}{O} = \frac{DI}{DO}$$

where O is the size of the object, I the size of the image, and DO and DI the distances to the object and image, respectively, from the hole.

Such a method of producing a magnified image is not feasible in practice because an infinitely small hole would require an object of extreme brilliancy in order to provide sufficient illumination to yield

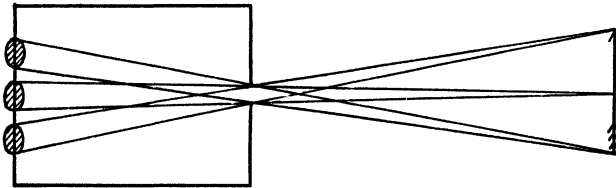

FIG. 6. Non-sharp Image Formation through Large Hole

an image. Enlarging the size of the hole results in increasing the light, but the image is then no longer sharp, the fuzziness increasing rapidly as the diameter of the hole increases. The reason for this, obviously, is that rays from a single point in the object no longer impinge on a single point in the image plane but are scattered over an extended area. Figure 6 illustrates this.

*Ignoring, of course, the effect of diffraction which must be present when light passes through a minute hole.

It is apparent that what is required is some means of bringing all the diverging rays from any given point in the object back to a similar point in the image, at the same time retaining the large aperture. This is accomplished by inserting a properly designed lens in the hole. A lens is a disc of glass or other transparent substance which, instead of having two plane parallel surfaces, has one or both convex

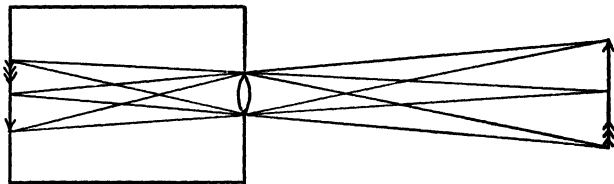

FIG. 7. Image Sharpened by Lens

(or concave). Thus, a lens of the type required to produce an image in the case under consideration would be thicker at the center than at the edges. With such a lens, the rays through the enlarged hole can be converged to a point and a sharp image once more produced, as illustrated in Figure 7.

Refraction of Light

To understand how this is accomplished it is necessary to consider a property of light which compels rays to bend under certain conditions. This bending is known as *refraction*.

We need not here consider the nature of light itself; we are interested only in such laws and phenomena as are related to the formation of an image. It will suffice to conceive of light as composed of undulatory rays emanating from a source and traveling through uniform media always in a straight line. But different media (i.e., air, water, oil, glass, and other transparent substances) offer different resistances to its passage through them, hence the rate of propagation of light varies accordingly. This results in an interference with its line of travel as it passes from one medium into another. This interference is not apparent when the rays fall perpendicular to the surfaces of the media, but at any angle to the perpendicular a deflection of the rays occurs. The direction of the bending and the exact amount of the deflection follow definite laws. Rays of light so bent

are said to be *refracted* and the law governing their behavior is known as the *law of refraction*. This law states that light in passing at an angle from one medium to another more dense (that is, one offering more resistance to its passage) is bent *toward* a perpendicular (to the surface) and conversely, in passing into a medium less dense, is bent *away from* the perpendicular. The angle which the oncoming ray makes with the perpendicular is called the *angle of incidence* and its angle after passing into the second medium is known as the *angle of refraction*. The ratio of the sines of these angles is always constant for any two given media regardless of the magnitude of the angle of incidence; consequently, by arbitrarily assigning a value of unity to air (all other transparent substances being more dense), the ratio of the angle of incidence in air to the angle of refraction in other media can be expressed as the *refractive index* of the latter. Ordinary glass has a refractive index around 1.5. Figure 8 shows in a graphic way just what takes place when light is refracted.

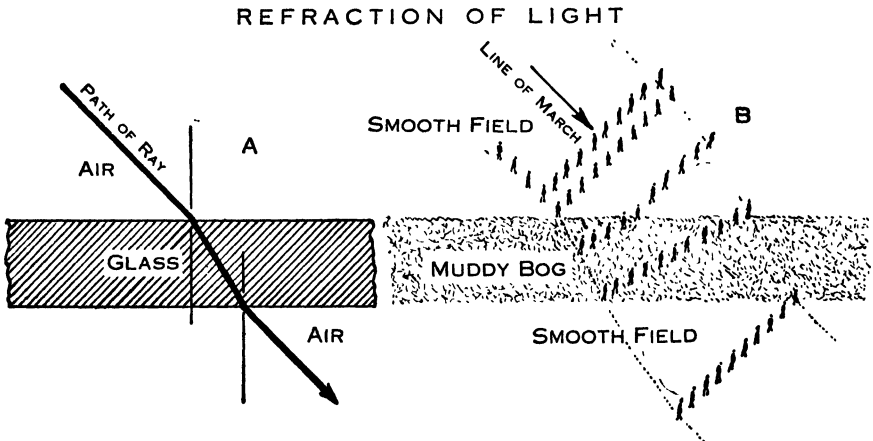

FIG. 8. Refraction of Light

So much in the science of microscopy depends on the effect of refraction — not alone in the construction of the lens systems but in practical work with the microscope — that a thorough appreciation of it is essential to securing the greatest efficiency the instrument is capable of giving.

Image Formation by a Lens

The functioning of a lens in image formation depends on the bending produced on rays from a single source impinging upon its curved surfaces at continually varying angles from the center to the outermost zone, the ratio of the sines of all angles of incidence and refraction on both entering and leaving the glass being constant (i.e., the refractive index of the particular glass employed).

Disregarding, for the time being, the presence of spherical and chromatic aberrations, the manner in which this is brought about can be shown diagrammatically (Figure 9). Here we see at *A* a double convex lens (i.e., one with a convex surface on each side) receiving

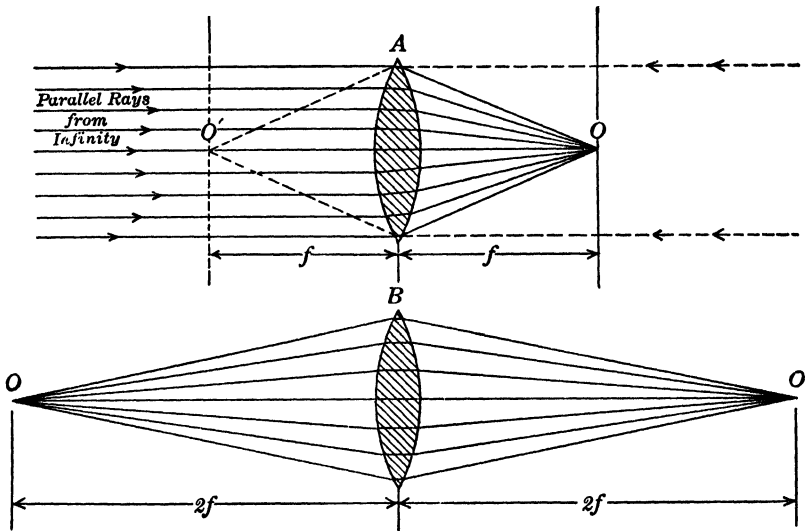

FIG. 9. Focus of Lens

parallel rays from a light source (e.g., the sun) located at infinity. The light source we will consider as the object. As the rays pass through the lens they are refracted at both surfaces and when they emerge are no longer parallel but converge toward the central axis; the axial ray, being perpendicular to both surfaces, is not refracted but continues through in a straight line. The symmetrical convergence of the rays means that they must all come together at some point

(O). In a plane through this point, parallel to the plane of the lens, will lie an image of the object from which the light is coming. Hence this plane is known as the *focal (or image) plane* and the axial point on this plane as the *focal (or image) point*. Then the distance from the optical center of the lens to this point is the focal distance (f), more commonly called the *focus* of the lens.*

The lens shown in Figure 9 (A) is symmetrical. It is therefore apparent that light rays could be sent through it from the right side as well as the left. A focal point (O') would then be formed on the left side, at the same focal distance from the lens. Conversely, if the light source (or object) were located at either of the focal points O or O' instead of at infinity, the rays would travel through the lens in a direction opposite to the first instance, but over an identical path. Thus they would leave the lens in a parallel beam and the image plane would be located at infinity. It is evident, then, that the image can lie at either the focal point or infinity, and, as obviously the object or light source can be moved anywhere between these two extremes, the image plane will move accordingly. As the light source is brought *toward* the lens, the image plane recedes from it, and vice versa. It follows that for every possible position of the object plane (beyond the principal focus) there is a corresponding image plane on the opposite side of the lens. At some position the object and image planes are equidistant from the lens. This condition occurs at double the focal distance, as shown in Figure 9 (B). The point where the lens axis passes through the object plane and the corresponding focal point lying in the image plane are known as *conjugate foci*, regardless of where the planes are located. For this reason it is customary to assume the object to be located at infinity and designate the distance from the lens to the image as the focal length of the lens.

Although it simplifies matters to consider the conjugate foci of a lens as lying in the optic axis, it must be remembered that for every point in the object plane there is a corresponding point in the image plane at the conjugate focus; it is the composite of all these points which reproduces the object as the image. Such an image is, how-

*Technically this is known as the *principal focus*, and the principal focus is implied by common consent when simply "focus" is used.

ever, inverted, as is apparent from Figure 10. The ratio of the size of the image to the object is the magnification as in a microscope, or the reduction, as in a camera.

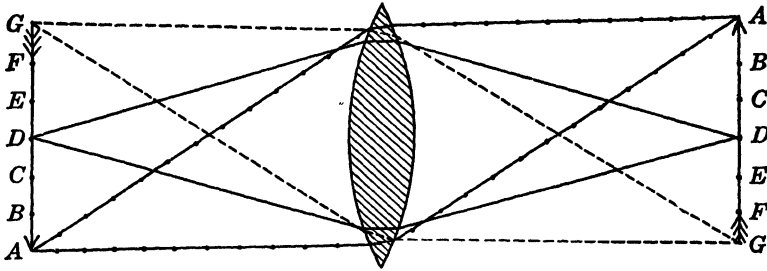

FIG. 10. Formation of Image

The changes occurring in the relation of the image to the object as the distances of the object with respect to the lens change can be tabulated as follows:

Object at infinity —	Image in focal plane, inverted, real, infinitely minified.
Object approaches the lens —	Image moves away from the focal plane, remains inverted, real, minified, but the ratio of minification decreases.
Object at distance of twice focal length —	Image at twice focal length, natural size, real, inverted.
Object moves closer —	Image moves farther away, remains real, becomes magnified, remains inverted.
Object at focal point —	Image at infinity. (Border between real and virtual image, between inverted and upright image.)
Object closer than focal length —	No more real image possible.

We can now appreciate why it is possible to substitute such a lens in place of the enlarged aperture in the box and obtain a sharp image of the object. One important restriction is, however, imposed in effecting the combination: the lens chosen must be such that its conjugate foci exactly correspond to the fixed object and image distances. With the minute hole the image is sharp regardless of the relative distances of object and image, but this is not the case when a lens

with a larger aperture is used. Only one focal length lens will be correct, unless either the object or image distance can be varied at will.

When the proper lens is found, it will be evident that the relation of image size to object has not been changed; the formula for determining it is still the same. As, however, the relations of the conjugate foci play an important part in the production of the image in the compound microscope and as the magnification is determined in a somewhat different manner, it will justify a brief discussion of the relation of the conjugate foci to each other and the method of determining their position with respect to the lens.

Locating the Conjugate Foci

In Figure 11 we have a double convex lens shown at $L-L$ whose focal length on either is fc and f_1c , f and f_1 being the focal points. These points lie on the axis $A-A$.

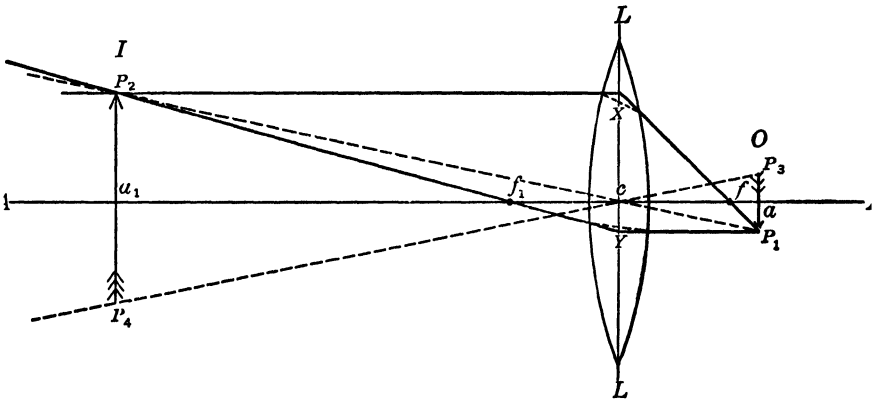

FIG. 11. Relation of Conjugate Foci

In following through any group of rays in a diagram of this kind, it must be appreciated that every point on the object is sending out rays; all of those reaching any portion of the lens must be deflected on the other side so they come together at the point in the image corresponding to the point in the object from which they originated. In our diagram the arrow at O represents an object, P_1 being the point and P_3 the tail, respectively. The simplest group of rays which

we can outline involved in the production of the image I would be that composed of rays corresponding to the rays forming the image if only the minute hole and no lens were present.

These rays are shown by the dotted lines P_1P_2 and P_3P_4 and are known as rays of minimum deviation, as they represent those image-producing rays which are least refracted.

We cannot learn from these alone how far distant the image I is from the lens; we only know that the point P_2 must fall on the line starting from P_1 and passing through C , the optical center of the lens.

In order to establish the distance we must determine the course of at least one other ray which also proceeds from P_1 . For a very good reason, we will choose the ray P_1X which passes through the focal point f . As has already been shown, every ray passing from f to the lens leaves the lens parallel to the axis, therefore xP_2 is parallel to $A-A$, and the point where xP_2 crosses P_1P_2 marks the actual position of P_2 , the arrow point of the image. While these two rays alone will establish the location of the image, we can add a third ray as a double check. We draw P_1y^* parallel to $A-A$. By our previous proposition this ray, after leaving the lens, passes through f_1 , then must continue on to meet at P_2 . We have thus located the position of the image I which corresponds to the position of the object O , or in other words established the conjugate focus ca_1 corresponding to focus ca .

Relation of Image Size to Object Size

Now for some relationships which will be found to play an important part later on in determining the magnification of a microscope. We have already seen that

$$P_2P_4 \text{ (i.e., } I) : P_1P_3 \text{ (i.e., } O) :: a_1c : ac,$$

demonstrated by the fact that triangles P_1ac and P_2a_1c are similar. But it is also apparent that triangles P_1af and xcf are similar and therefore

$$xc : P_1a :: cf : af.$$

*For simplicity x and y are shown as though the bending of the rays takes place in the center of the lens. Actually the refraction is at each surface as indicated by the dotted path.

xc however is equal to P_2a_1 (one half the image I) while P_1a is one half the object (O), cf is the focus of the lens and af is the distance of the object from the focal plane. Hence the relation of the image to the object can also be expressed (substituting in the last equation) as,

$I : O :: \text{lens focus} : \text{object distance from focal plane.}$

Conversely, we can prove the corresponding triangles on the image side of the lens similar and thus derive another expression of the relation of I and O , as follows,

$I : O :: \text{Image distance from focal plane} : \text{focal length or}$

$$\frac{I}{O} = \frac{\text{Image distance from focal plane}}{\text{focal length}}$$

From these expressions of the relation of I to O , it can be appreciated why only one focal length of lens could be placed in the aperture of the box with fixed object and image distances, and yield a sharp image. Under such a condition the only variable is the focal distance cf (and cf_1). The focal distance is determined by the curvature of the lens surface and the refractive index of the glass (or other transparent medium) from which it is made.

Comparing two simple plano-convex* lenses, alike except as to the radii of curvature of the convex surfaces, we find that their foci are to each other as the radii of curvature of the convex surfaces. That is, if the radius of one be twice that of the other, its focus will be twice as long also. The actual focal length will depend on the refractive index of the glass employed; when the latter is 1.5, the focus is exactly twice the radius. The diameter of the lens does not play a part in determining its focus, but, on the other hand, the diameter of any given lens is limited by its radius of curvature, the absolute maximum being twice the radius of curvature; in other words, such a lens would be a hemisphere. All segments cut from the surface of a given sphere would have equivalent focal lengths (neglecting the effect of spherical aberration and glass thickness), for all radii of curvature would be identical.

*I.e., flat on one side and convex on the other.

Kinds of Lenses

In every lens we must reckon on two surfaces. These need not be of similar curvature; one surface may be flat, convex, or concave and the other either convex or concave. The radii of curvature can vary on lenses with two curved surfaces. This gives rise to a considerable number of possible combinations, such as those shown in Figure 12

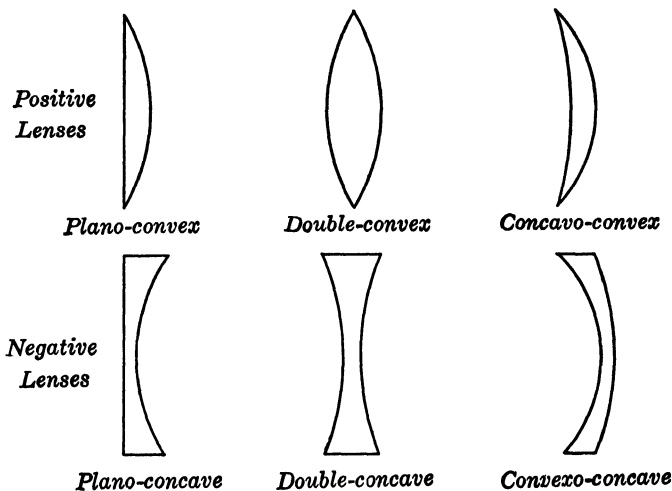

FIG. 12. Types of Lenses

with the designation by which each is known. Only lenses which are thicker in the center than at the outer edge will function to produce an image such as that diagrammed in Figure 9. These are accordingly known as *positive lenses*. Lenses which are thinner in the center disperse or spread parallel rays, so they can never produce an image,* are called *negative lenses*. If parallel rays are sent through a convex (or positive) lens adjacent to a concave (negative) lens of similar focal length, they will exactly neutralize each other and the rays will emerge parallel as they entered. As will be seen later, it is because of this condition and the possibility of having an almost infinite number of surface combinations out of glasses with different characteristics that high-grade optical results are possible. In the

*The term "image" is employed here for simplicity, meaning a *real* image. Negative lenses produce *virtual* images, which in effect are imaginary images.

case of high-power, highly corrected microscope objectives, as many as ten or twelve individual lenses may be combined to function as a single lens. Such combinations have a resultant combined focus which is expressed as though only a single lens were present, the term *equivalent focus* designating this condition.

Formation of Image in the Eye

Once the operation of a simple convex lens in the formation of an image is understood, we are in a position to appreciate the part the human eye plays in combination with a simple magnifier and then with the compound microscope.

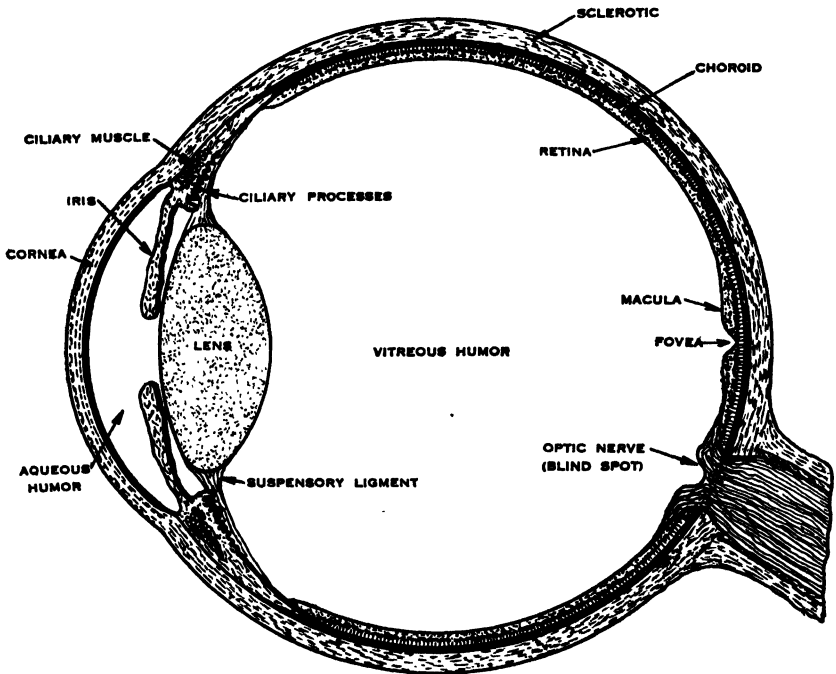

FIG. 13. A Cross-section through the Human Eye

The eye itself is, in the last analysis, nothing more than a light-tight box properly equipped with a lens, although provided with marvelous automatic adjustments and refinements.

Figure 13 is a diagram of the human eye with some parts desig-

nated. Although equipped with a highly refractile lens, actually all the anterior portion (including the cornea, aqueous humor, and iris) is a part of the lens system necessary to the production of a highly corrected image. The image in the eye is received on the retina, which is curved to embrace a wide angle, but only that portion which falls on the macula at the posterior axis is at all critical.

The eyeball is a sphere. It is at once apparent that the position of the lens with reference to the image plane cannot be changed. Such a change, according to the principles already discussed, is of vital importance in the formation of a sharp image as the object distance varies.

How is it possible, under this condition, for us to discern objects sharply, whether they be located at infinity (e.g., the stars) or only a few inches away? Does this controvert the theory of image formation? The answer to these questions constitutes one of the marvels of design in the eye.

The eye obeys every physical law relating to image formation, but as it cannot accommodate for varying object distances by a change in the conjugate image focal length, it takes advantage of the other possible variable: *the focal length of the lens changes.*

The lens, instead of being composed of an inflexible material like glass, is very elastic, like rubber. When freed of all restraining forces it decreases its diameter and thickens in the center to form a lens of shorter focus. It is prevented from doing this through attachment by the suspensory ligaments, to the eyeball at its periphery. The pull of these suspensory ligaments keeps the lens expanded the proper amount. A normal eye, therefore, focuses for distance (or infinity) under this condition. The forces being just balanced, the eye is said to be at rest when focused for distance.

Attached to the eyeball around the outer edge of the lens is a muscular ring known as the ciliary muscle. When an object moves closer the ciliary muscle contracts, counteracts a portion of the eyeball pull, upsets the equilibrium, and the lens expands accordingly, just enough to shorten the focus and restore sharpness to the image once more.

All this takes place automatically and can continue until, in the normal eye, the object reaches a distance of about ten inches from

the eye. Beyond this point the muscular strain involved in accommodation becomes uncomfortable. This ten-inch dimension, as we shall show, plays an important part in magnification.

One might naturally think, in following the analogy between the lens image in the box and the image in the eye, that something is wrong somewhere. In the first example the image is inverted. In the second, we see things right side up. The explanation lies in the fact that the image is also inverted in the eye, but a transposition is effected in the nerves which pick up the image and transmit it to the brain, thus making it appear right side up.

Magnification as Accomplished by the Eye Alone

If magnification can be effected in a lens-equipped box, as we have seen, by the simple expedient of bringing the object closer, it is evident that the same must be true of the human eye. It is therefore desirable to consider some of the factors involved in magnification when the eye is taken into account, for these will later be found to have a bearing on the final magnified image when the microscope is employed for visual purposes.*

We must start with a basic law often overlooked in its relation to the microscope. This is, that the apparent size of an object is in direct relation to the angle it subtends to the eye; all objects subtending the same angle appear the same size regardless of their actual dimensions. How well the general principle back of this law is known is expressed in the old adage, "You can hold a penny so close to the eye that you can't see a dollar behind it."

Actual size and apparent size, according to this law, do not necessarily bear any direct relationship to each other. It is evident, then, that at least one other factor must be considered in determining magnification: the factor of distance between the eye and the object. The law operating in this instance states that the angle subtended by the same object varies (almost) inversely as the distance between that object and the eye. That is, if we halve the distance, the angle

*This distinction is made to differentiate visual use of the microscope from projection or photographing, where the eye is not concerned in the formation of the image.

subtended will be doubled. This is demonstrated in Figure 14 where the object (the arrow) is of the same dimension in each position, the distances being $3d$; $2d$; d , the associated angles, being 10° , 20° , and 30° . It follows from this that the simplest method of obtaining magnification is to bring the object nearer to the eye. This procedure suffices if the object is of appreciable magnitude, but it fails

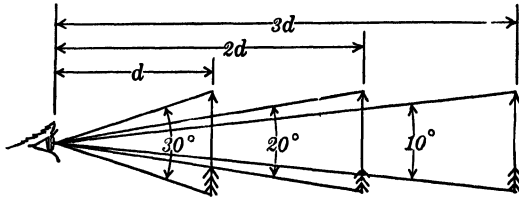

FIG. 14. Size of Object at Varying Distances

completely beyond a certain minimum object size. This is due to the interjection of the factor already mentioned: the inherent limitation in the eye which makes it difficult to focus sharply on objects closer than ten inches.

We are also faced with the operation of still another law. This relates to the actual size of the object. That is, at a fixed distance (say ten inches) the angle subtended by an object varies (almost) directly as the size of the object. Hence, assuming monocular vision, only when the distance is identical can the relative size of two objects be compared.*

As long as the size of an object is sufficient to subtend an appreciably large angle at a distance of ten inches from the eye, further magnification may be unnecessary. However, as the size diminishes, a point is reached when structural details begin to disappear. Finally, when the angle reaches about $1.4'$, corresponding to an object dimension of the order of $\frac{1}{250}$ of an inch (100 microns), the limit of visibility is reached. The object then becomes invisible when distant

*Actually the relation is between the tangents of half the subtending angles; hence to say that the size of an object at a fixed distance varies directly as the subtending angle, is not strictly correct. At 30° , however — a fair upper limit when dealing with microscopical magnification — the ratio to an object subtending 15° would be as 26.80 is to 13.17, which is near enough to 2 to 1 for all practical purposes.

ten inches from the eye.* Yet this same object, just invisible when ten inches away, would again become visible if it could be moved to a point five inches distant and still be in perfect focus, for such a change in position would result in a two-times enlargement. It now becomes evident that if the object could be placed one inch from the eye, still sharply focused, it would be magnified ten times. At one-half inch it would be magnified twenty times. All without the use of a microscope of any sort! This, of course, is impossible, although there are many near-sighted individuals capable of focusing on an object five inches away, or even less. Such individuals can see detail not visible to the average eye.

A question is apt to suggest itself here: "If the eye cannot focus sharply on an object only an inch from it, would it not be possible to insert some kind of a lens between the eye and object which would supplement the lens of the eye and bring the image into sharp focus?"

The answer is "yes," but in that answer and the manner of accomplishing the result lies the basic principle of the simple microscope and the possibility of the compound microscope.

The Simple Microscope

The term "simple" microscope is applied to a single lens (or a combination of lenses more or less corrected but functioning as a single lens) when used to aid the eye in producing an enlarged image

*This statement must be accepted as representing a general principle rather than as implying the resolution of detail, where another condition is involved. Actually, there is almost no limit to the size of an object which can be seen by the eye if the contrast between the object and background be sufficiently great, as it is only necessary that the image fall on a single cone in the retina. Of course, when the object is black against a white background, the effect of fogging results in a limitation. This is due to the light from the background striking the same cone as that which the image falls on, cutting down the differential and obscuring the image. The practical limit under this condition is an object size such that its image will fully cover one cone in the fovea. Under the reverse condition, a bright object against a black background, this limitation is not present; only a minute portion of a rod or cone need be covered. An example of this is found in the ability to see the stars at night, or a point source of light reflected from a spherical mirror. The discerning of detail, as discussed elsewhere, is something quite different. Two dots can be resolved or identified as such only when they are sufficiently separated to enable their images to fall on two different cones in the retinal fovea. Here the limitation is not the diameter of a rod or cone but the distance between two cones within the area of the macula lutea.

of an object on the retina (i.e., to make it subtend a greater angle than that subtended by the object itself when located ten inches from the eye).

In magnification such lenses range from two to twenty diameters. The term *diameters* implies the ratio between the angles subtended by the image and object at ten inches. Various names are applied to lenses of this kind, such as reading glasses, magnifiers, loupes, linen testers, etc., and there are various modifications in design and degree of performance. Figures 15A and 15B show some forms in section, with the names by which they are known.



FIG. 15A. Types of Simple Magnifiers

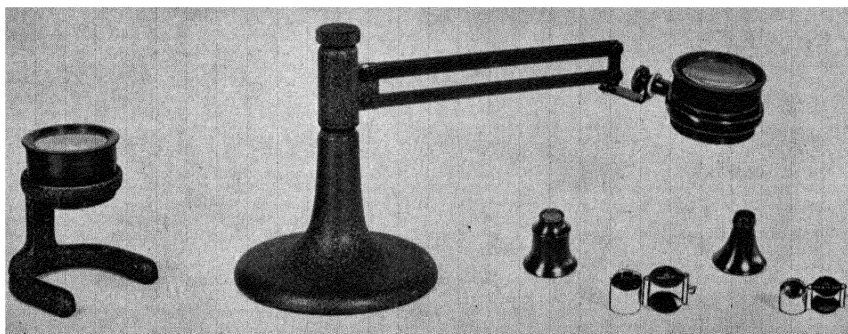

FIG. 15B. Types of Simple Magnifiers

(Courtesy of Bausch and Lomb Optical Co)

Virtual Image Formation by a Magnifier

The manner in which a simple magnifier functions in collaboration with the eye in producing an enlarged image differs from the methods previously discussed.

Images of the sort produced by a positive lens at its conjugate-image focal plane are true images, in the sense that they can be thrown on a screen or photographed just as though they were objects themselves. The term *real* image is applied to them. This, however, is not true of the image produced by the same lens when it is used as a magnifier, directly before the eye. In this case the object must be located closer to the lens than the principal focus, and we have seen that real, finite images can be formed only when the object lies *outside* the principal focus. If the object is located exactly *at* the focus, the image is formed at infinity.

Perhaps the following explanation offers the simplest approach to the manner in which the eye and lens function together under this condition:

When the object lies within the focus, the rays from any single point in it will diverge after leaving the lens, as shown in Figure 16 (A). Hence the rays would never come together again to form an image of that point. Now, if we draw the outermost rays reaching the eye from a single point in an object located ten inches away, as in Figure 16 (B), we find that they too diverge. Yet they are brought to a focus by the eye lens, and a real image is formed on the retina. If, therefore, we place the lens shown at *A* directly in front of the eye focused as in *B*, it is obvious that the eye can take from the lens the central rays which are not diverging more than if the point were located ten inches away, and can bring them to a focus and produce an image out of rays, which could not, of themselves, form an image. This combination is shown in Figure 16 (C). Images of this type are called *virtual images*, because, although visible to the eye, they do not exist apart from the eye. In this case, too, the image is not inverted, but erect. Hence a simple magnifier does not show objects upside down. Another example of a virtual image is one seen in a mirror.

Magnification with a Virtual Image

At this point the question arises of how we can determine the magnification of a virtual image if it be not real. This is where the ten-inch distance of best normal vision comes in. It becomes a reference distance against which the subtending angle of the virtual

image can be projected and compared to that of the object itself when located ten inches from the eye.

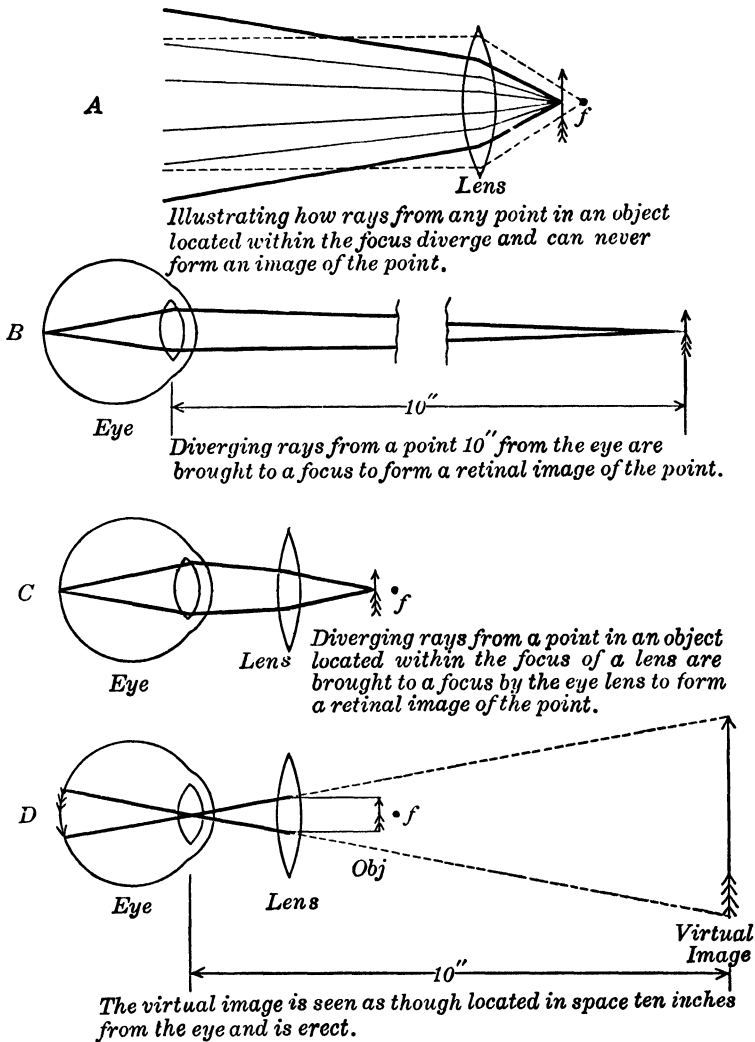

FIG. 16. Image Formation with Magnifier

To illustrate, let us take an object one-eighth of an inch in diameter and place it at the ten-inch position. It will subtend an angle of $0^{\circ} 43'$. If brought to a position one inch from the eye the angle

will be $7^\circ 10'$, ten times as great, but not in focus. Now we experiment with various lenses held close to the eye until we find one that also makes the angle of the virtual image $7^\circ 10'$ when sharply focused. Such a lens will prove to be a lens of one-inch focus, or one-tenth of ten inches, the distance of best vision. This is also the focal length equal to the distance from the eye where the object itself subtends the same angle, though not in focus. This relationship exists in all cases where the lens is used as a magnifier, close to the eye. We can derive the formula for the magnification, therefore, as

$$\frac{\text{Distance of best vision}}{\text{focal length of lens}} = \text{magnification.}$$

When the focal length of the lens is expressed in millimeters, as is customary in optical apparatus, the distance of best vision must be taken as 250 mm., the approximate metric equivalent of ten inches.

The path of the extremity rays from the object to the eye through the magnifier, with the projection of the virtual image at the ten-inch distance, is diagrammed in Figure 16 (D).

The Compound Microscope

The compound microscope in the simplest sense is merely one in which a double magnification takes place. One lens gives a primary enlargement of the object under observation, which is then picked up and further enlarged by a second lens, operating as a magnifier. The first lens, that nearer the object, is known as the *objective*; the second lens is the *eyepiece* or *ocular*. The possibility of effecting the second enlargement rests in this fact: the image formed at the conjugate focus of the objective (which we have conceived of as being projected on a screen just as with a stereopticon) exists in space, even if no screen be there to receive it. Consequently, just as a second magnifier could be used to study the image on the screen at higher power, so it can pick up the image on the image plane in space, providing it is focused upon it. The result seen by the eye is a magnified virtual image of a magnified real image of the object. This is shown in the schematic diagram in Figure 17. Here the objective (*obj.*) is projecting an image (*I*) of an object (*O*) lying in the plane

of its front conjugate focus, at its back conjugate focus. This image I lies in the plane of the front conjugate focus of the eyepiece ($E.P.$). Consequently, at its corresponding back conjugate focus an image (I') will be formed. This latter enlarged image can be thrown on a screen and thus become visible. If it be received on a photographic plate, a picture of it can be taken. The size of the image (I') will be determined by the distance (D) the image plane is from the eye-

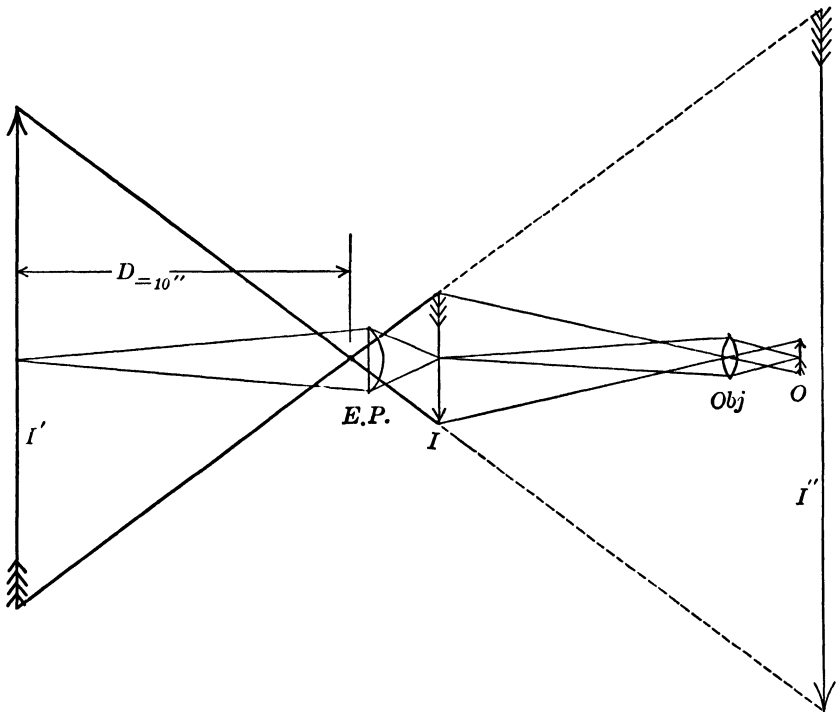

FIG. 17. Schematic Diagram of Compound Microscope

piece ($E.P.$). By placing the eye where it can pick up the rays from the eyepiece and by slightly altering the distance between the objective and the object so as to bring I within the principal focus of the eye lens, there will be seen in front of the eyepiece an enlarged virtual image (I''), which at ten inches distance would appear the same size as when projected at I' at ten inches.

Aberrations in Lenses

Now that we have established the simple fundamental principles underlying magnification and outlined the theory of the compound microscope, it is in order to consider other optical conditions entering into the formation of a high-quality image, in both the simple and the compound microscope.

It has been necessary, in order to visualize the way in which a lens functions, to make certain assumptions which are not actually true in fact. In other words, we have assumed ideal conditions which do not exist; there are some inherent defects (classed under the general

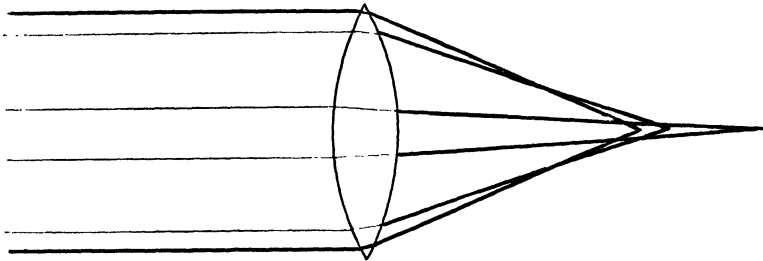

Spherical Aberration

FIG. 18. Spherical Aberration

term *aberrations*) in a simple lens which must be comprehended in order to appreciate the length to which the optician must go in order to produce objectives of a high order. Indeed, it is the degree to which these defects have been surmounted which constitutes the difference in image quality between first-class objectives and those of mediocre grade.

Spherical Aberration

Figure 9 shows all the parallel rays entering a lens and coming to a focus at a point. This is not what actually happens. The rays which pass through the margin of the lens are refracted more than those nearer the center, as shown in Figure 18. In fact, every zone of the lens from center to circumference has a different focal length. This defect is known as *spherical aberration* because it is due to the fact that lens surfaces are segments of a sphere. If the marginal rays

be cut out by means of a diaphragm a fairly sharp image results; likewise, if the central rays are blocked out, the marginal rays yield a good image, but the image plane is much nearer to the lens than in the case of the image formed by the central rays. Any attempt to combine the images from both central and marginal zones results in a fuzzy image no matter where the image plane is placed, for when one is sharp there are other images superimposed upon it which are out of focus.

Methods of Correction for Spherical Aberration

If we are to have a perfect image, it is obvious that this defect must be eliminated so that every part of the lens focuses exactly on the same plane. Theoretically, the simplest way to accomplish this would be to grind the curvature of the lens surface so that the marginal zones would have sufficiently increased radii to bring their foci to the same point as that of the central rays. Such a lens would not be a portion of a sphere; in other words, it would be *aspheric*.

Mechanical difficulties involved in the grinding of an aspheric surface preclude the use of this method as a practical way of making microscope lenses. On the other hand, such lenses are produced in larger sizes suitable for condensers for illumination purposes, although they are quite expensive. Fortunately, there is another way in which the same result can be obtained. This is through the use of a compound lens having two or more components, made from glass with different refractive indices. The more common form consists of three lenses, cemented together, the central one a double convex element of short focus, those on each side being negative meniscus lenses. Such a lens is illustrated in Figure 19.

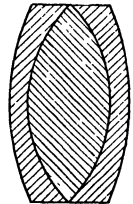

FIG. 19.
Three Lens
Correction
for Spherical
Aberration.

Here every surface of each component is spherical, making them easy to grind, yet the effect of the greater thickness of the negative lenses in the outer zones has effected an aspheric surface equivalent for the combination as a whole, the central and marginal rays being now brought to focus at the same point. Lenses in which spherical aberration has been eliminated by this or equivalent means are known as *aplanatic* or *aplanats*.

Chromatic Aberration

In addition to spherical aberration there is yet another inherent condition which must be overcome in order to produce high-quality images. This, *chromatic aberration*, is due to the fact that white light consists of rays of different wave lengths which are not refracted the same amount. In most media, the shorter (violet) rays are bent more than the longer, (red) rays. It is due to this behavior of light waves that we are able to separate white light into its component colors by passing it through a prism, the result being the band of color known as the *spectrum*.

The amount of separation of the red and violet effected by a transparent medium is known as its *dispersion*. The manner in which it affects an image formed by a simple lens is shown in Figure 20A.

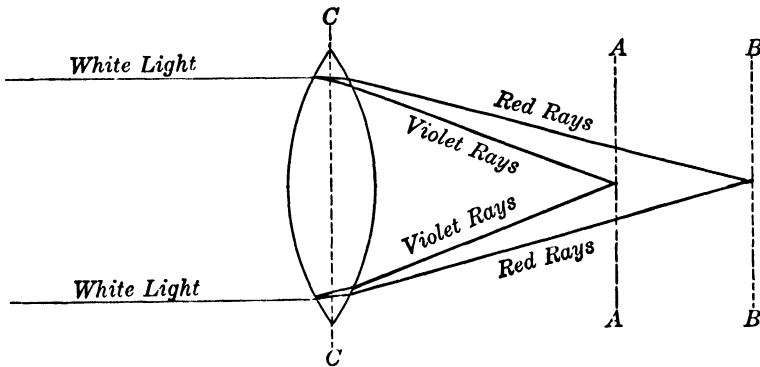

FIG. 20A. Chromatic Aberration in Simple Lens

If the object were to send out only monochromatic violet light, all other rays being suppressed, a sharp image (of a violet color) would be formed in the plane *A*. No chromatism would be present. Similarly, if the light were a monochromatic red, a sharp image (red in color) would result, but it would lie on the plane *B* and would be correspondingly larger than the violet image, in the ratio $CB : CA$. Each intermediate color would have its own focal plane lying somewhere between *A* and *B*. Thus there could be no plane of perfect focus for white light (a mixture of all rays), and color fringes would interfere with sharp delineation of the images. Therefore, one of two things must be done to secure a quality image: either employ

monochromatic light of a definite wave length to the exclusion of all other, or find a way to bring all the rays to the same focus. In certain limited cases in microscopic work the former method is employed; ordinarily a high degree of correction in bringing all rays to approximately the same focus is effected by the use of composite lenses, as in the case of spherical aberration.

Correction for Chromatic Aberration

The possibility of making correction for chromatic aberration is due to the fact that we can make optical glass which varies not only over a wide range of refractive index but also in the degree of dispersion. Thus there can be four extremes in the types of glass available; with combinations of these and lens surface curvatures, it is possible to make combined corrections for both chromatic and spherical aberration. These four types of glass are:

Low Refractive Index with Low Dispersion

Low Refractive Index with High Dispersion

High Refractive Index with Low Dispersion

High Refractive Index with High Dispersion

Through the use of certain combinations of these it is actually possible completely to reverse the natural chromatic aberration of a single lens so that the red focus lies inside the violet as illustrated at *B* in Figure 20B. This condition is known as *over-correction*.

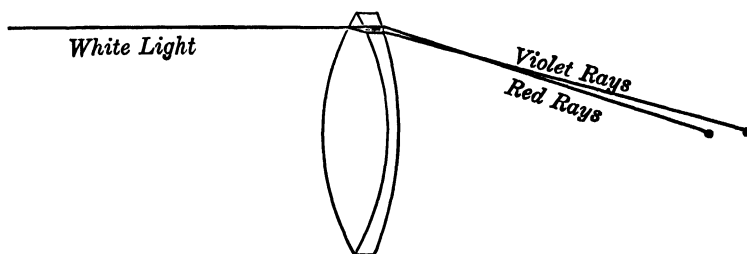

FIG. 20B. Over-correction in Doublet Lens

Correction for chromatic aberration must be superimposed on the spherical aberration correction in order to yield fine images. This necessary correction involves theoretically every visible ray from violet to red, in all zones from central to peripheral, being brought to

focus on the same plane. Such an ideal is impossible of attainment in the so-called *achromatic objectives*. The best that can be hoped for is an approximation of this condition. This is accomplished by choosing one color, usually the yellow-green (because the eye is the most sensitive in this region), as the preferred band and correcting for spherical aberration and coma* in the plane of the shortest focus, for this particular spectrum region. Then it is possible to condense the natural spread of the orange and red somewhat, not, however, effecting a full correction to bring them to the exact plane of the yellow-green rays. The portion of the spectrum lying on the opposite side of the yellow-green is then over-corrected so that the blue-violet is superimposed on the orange-red. The total effect results in a fine order of correction in the preferred plane with but little color fringe.

With the development of new types of optical glasses and the use of the natural mineral fluorite, lenses of a still higher degree of color correction were developed by the late Ernst Abbe. To these the name *apochromatic* was given. In these lenses three colors instead of two have been superimposed, and the secondary spectrum eliminated. Except for a slight difference in the magnification of the colors (blue being in excess of red) — which, as will be seen later, is compensated for in the compound microscope by the use of special over-corrected eyepieces — the correction is almost perfect. An intermediate type of lens, superior to the achromats but not quite the equal of the apochromats is also available, under the name *fluorites*, often referred to as *semi-apochromats*.

Mechanical Design of the Compound Microscope

Before going further into the optics of the compound microscope it is desirable to consider the mechanical form of a conventional instrument. The design of the apparatus is the natural outgrowth of a need for supporting the lenses in optical alignment at fixed dis-

*In correcting for spherical aberration it is necessary to obey what is known as the sine-law; that is, the ratio of the sines of the angles of entering rays for all zones in all positions on the object plane to the corresponding sines of the angles of the emerging rays must be the same, the ratio being the magnification of the lens; otherwise a defect known as *coma* will be present in the lens.

tances from each other and in proper relation to the object; the need for suitable illumination; provision for changing lenses to vary the magnification; and all the other requirements to facilitate rapid work.

Figure 21 shows diagrammatically a modern instrument of fairly simple conventional form, but combining all essential parts. The objective and eyepiece are mounted in the *tube*. The objective screws into the bottom of the tube. The eyepiece is a sliding-fit in the top. The threading of the tube is now standard for all makes of instruments, both European and American. It is known as the Royal Microscopical Society standard thread.*

Its use makes it possible for all objectives of any manufacturer to be employed on any microscope equipped with it. Although the objectives may be screwed directly into the tube, the need for constantly changing objectives for the various magnifications required is met by the use of a turret head known as a *nosepiece*, into which can be screwed two, three, or four objectives, any one of which can be swung into position for instant use. (Some other forms of quick-changing devices are preferred under certain conditions.)

The standard size eyepiece has a diameter of 23 mm. (.917 in.) and is employed on the majority of modern instruments. Older models are sometimes found with the large-size eyepiece which has a diameter of 32 mm. (1.27"). A few of the more elaborate modern instruments for special work (e.g., petrographic microscopes and photographic outfits) are equipped for a 30 mm. eyepiece.

The length of the tube from the shoulder against which the objective screws to the top where the eyepiece rests is known as the *mechan-*

*The specifications of the Royal Microscopical Society standard screw thread for objectives are as follows:

Diameter — 0.800 in. (20.3198 mm.).

Pitch — 36 to the inch (14.17 to the cm.).

Form — Whitworth screw, i.e., a V-shaped thread, sides of thread inclined at an angle of 55° to each other, one-sixth of the V depth being rounded off at the top and the bottom of the thread.

Length of thread on objectives — 0.125 in. (= 3.1750 mm.).

Plain fitting above thread of objective — 0.1 in. (= 2.5400 mm.) long, not to exceed 0.09 in. (= 19.2784 mm.) in diameter.

Length of screw of nosepiece to be not less than 0.125 in. (= 3.1750 mm.).

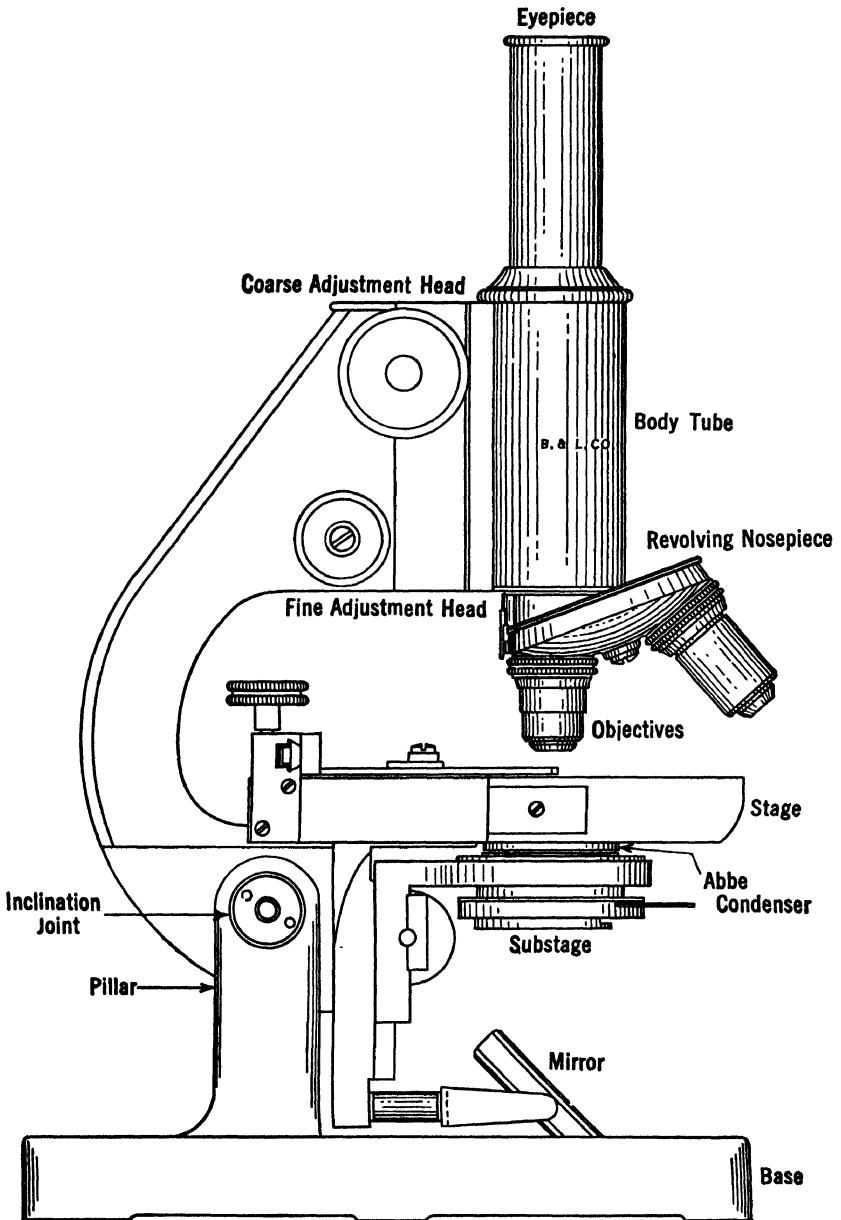

FIG. 21. Typical Microscope with Parts Named

(Courtesy of Bausch and Lomb Optical Co.)

ical tube length.* All good instruments (except those for very special purposes) have the tube equipped with an inner sliding *draw tube*, which serves several purposes.† Although it can be pulled out so as to give higher magnifications, this is not a desirable use of it for any except very low-power objectives. Primarily, it enables the tube length to be adjusted to the correct length when certain accessories are screwed on between the tube and objective or when one uses objectives designed for a longer tube length. As will be seen later, it can compensate to some extent for cover-glass thickness, and as it is threaded at the lower end with the Royal Society thread, very low-power objectives can be screwed into it in cases where the extent of focusing adjustment provided is not sufficient for them.

Below the tube is the *stage*, on which the objects are placed for examination. The stage is either square or round. The round type is usually rotatable and centered so that an object will remain in the optic axis of the objective during rotation. The stage is provided with *spring clips* for retaining microscopic slides. In instruments designed for high magnification means for moving the slide on which the object is mounted (frontally and horizontally) are often provided. Such a device is known as a *mechanical stage*. It can be either built in, as an integral part of the instrument, or made detachable. It is also possible to obtain mechanical stages for application to instruments not originally equipped with them. The arm attaching the tube to the stage has two mechanisms within it for focusing the tube with relation to the object. The *coarse adjustment* is usually accom-

*The *optical tube length*, as will be seen later, is different from the mechanical tube length, but is not of so much importance to the ordinary microscopist in the practical operation of the instrument. It is always the mechanical and not the optical tube length which is engraved on the objective. It is definitely established by each manufacturer for his objectives. In the early days of the microscope this tube length was set at 10" (250 mm.), the distance of best normal vision, but this resulted in such cumbersomeness of design that it was abandoned for a shorter one. The present common tube length is 160 mm., although a few European firms (e.g., Leitz) standardized at 170 mm.

†It is to be regretted that the latest tendency of several manufacturers in microscope design is to omit the sliding tube. The reason given for this procedure is that the average microscopist does not know how to use the draw tube and may therefore obtain poor images by an improper use of it. The obvious saving in manufacturing cost, however, suggests an ulterior motive. In view of the many important advantages of the sliding draw tube with its Royal Society thread at the bottom, it should be available for those who have need of it. Further, means should be taken to train operators so that it may not be used improperly.

plished by means of a rack and pinion with a total movement of two or three inches. The *fine adjustment* device provides a very slow motion for final focusing, with a total movement of only a small fraction of an inch.* The *arm* is attached to the *base* or *foot* supporting the instrument, usually by means of an *inclination joint*. This joint permits use of the instrument in a vertical or horizontal position (for photography or projection) or permits its inclination at any intermediate angle to suit the individual user.

In American and continental European models the flat horseshoe form of base is used almost exclusively. English manufacturers have a strong predilection for the high tripod foot, which they feel provides greater stability. Older models of the horseshoe base undoubtedly offered less stability and some can be found that will hardly stand unsupported with the instrument in the horizontal position; that is, the center of gravity falls to the rear of the hindmost point of the base. When proper attention is given to the design of this feature, the horseshoe or rather flat form is generally to be preferred.

Attached below the stage is the *mirror arm* with a double-faced (plane and concave) *mirror* centrally placed in the optic axis. Between the mirror and stage is mounted the *condenser*, the function of which is to provide an illumination cone of light ample for any objective that may be used. The angular aperture of this cone of light is controlled by means of a *diaphragm* under the condenser. Vertical adjustment of the condenser is accomplished in one of three ways, depending on the elaborateness of the instrument: by a sliding-fit in a sleeve; a quick screw at the side; or a rack and pinion as provided for focusing the tube. In the more elaborate condenser units means are provided for decentering the diaphragm and rotating it so that the light can come from any azimuth.

This, in general, covers the essentials of the microscope in its conventional form and the relation of the several parts. Each of these in turn will come up for further consideration in the proper place.

We have discussed some of the fundamentals involved in the optics of the objectives. It now remains to consider how these have been worked out in a practical way in the finished products of the various

*Less expensive instruments sometimes have a sliding-body tube substituted for the coarse adjustment; some others have no fine focusing device.

manufacturers; how other optical conditions affect the performance of lenses; and which conditions can be purposely varied within limits to enable the instruments to yield specifically desired results.

The Magnification of Compound Microscopes and its Determination

Naturally, conditions arise in microscopy requiring magnifications ranging anywhere from a very low power of only a few diameters up to the highest theoretically possible. Therefore a considerable number of objectives and eyepieces are necessary to meet this demand. The computation of magnification for simple lenses has already been given; extending this same method to the compound microscope now becomes simple. For if one lens magnifies 10 times ($10\times$) and a second lens again magnifies the enlarged image another 10 times ($10\times$), then the final magnification is $10 \times 10 = 100$.

Determining the magnification of the combination in use, in the case of modern instruments and objectives, involves no severe mental exertion, as the current universal practice is to engrave the initial magnification on each objective and the eyepiece magnification on the various oculars. The mechanical tube length is also engraved (or should be) on the objectives, because it is necessary to employ the proper tube length for which the objective is corrected, not only to secure the best optical performance but also to obtain the rated magnification. If the objective is used on a longer tube the magnification will be increased, and conversely, decreased on a shorter tube.

The method of determining magnification for older objectives and eyepieces, and the relation of the equivalent focus of the objective to its initial magnification, warrants discussion, especially considering the apparently conflicting information one is sure to run across in various books, catalogues, and publications. (This conflicting information is closely tied up with the history and development of the microscope.) The magnification of a lens when used as a magnifier has already been shown to be ten inches (the distance of best normal vision) divided by the focal length of the lens. The eyepiece, used in this way, has, with few exceptions, always been figured in this manner. For example, a one-inch eyepiece would give $\frac{10}{1}$ or ten times magnification. Objectives were formerly conceived of as

having a similar magnification when used as magnifiers, and were then computed so this initial magnification would be realized when used on a tube having a mechanical tube length of ten inches. Thus a one-inch objective would give an initial magnification of $10\times$, which, used with a $10\times$ eyepiece would give 100 diameters.*

As has already been stated,† the cumbersome ten-inch tube was ultimately replaced by the short tube (160 mm. — Leitz 170 mm.). This introduced the first complication to upset the conventional method of computing magnification, for, according to the laws already discussed, if a lens gives an image of a certain size at a distance of 250 mm. ($10''$) it would yield only $\frac{160}{250}$ of this size at 160 mm. distance. However, in computing the final magnification for the short-tube microscope, it would not matter in the result whether the initial magnification of the objective or the magnification of the eyepiece were reduced to $\frac{160}{250}$ of the previous value. The Zeiss Company chose the latter method. They pointed out, however, that the magnifications of the various eyepieces held good for the higher

*As an illustration of this, the Royal Microscopical Society published for general distribution a chart of magnifications in which the initial magnification of the entire series of objectives corrected for use on a 10-inch tube is given as follows:

Focal length	Magnifying power	Focal length	Magnifying power
5 inches	2	$\frac{4}{10}$ inch	25
4 inches	$2\frac{1}{2}$	$\frac{3}{8}$ inch	30
3 inches	$3\frac{1}{3}$	$\frac{2}{5}$ inch	$33\frac{1}{3}$
2 inches	5	$\frac{1}{4}$ inch	40
$1\frac{1}{2}$ inches	$6\frac{2}{3}$	$\frac{3}{8}$ inch	50
1 inches	10	$\frac{1}{6}$ inch	60
$\frac{8}{10}$ inches	$12\frac{1}{2}$	$\frac{1}{5}$ inch	70
$\frac{7}{8}$ inches	$13\frac{1}{3}$	$\frac{1}{6}$ inch	80
$\frac{6}{8}$ inches	15	$\frac{1}{5}$ inch	90
$\frac{5}{8}$ inches	20	$\frac{1}{4}$ inch	100

This table has naturally been copied into various books on the microscope.

In the 35th edition of the Zeiss catalogue, published in 1913, the following note on the initial magnification of the objectives occurs:

"This is the magnification which the objective would give at the distance of distinct vision if used without eyepiece, i.e., as a simple magnifier. The initial magnification is found by dividing the focal length of the objective, expressed in millimeters, into 250, which is the distance of distinct vision expressed in millimeters. For example, the initial magnification of a 3 mm. objective is $250:3 = 83.3$."

†See note, page 43.

powers only, and that they would vary within certain limits when used with different objectives. Most other manufacturers chose the somewhat more logical method of reducing the value of the initial magnification of the objective.

Following the advent of the short tube another marked improvement was made. This was the manufacture of a *parfocal* series of objectives. That is, the optical and mechanical characteristics of each were so designed that the objectives could be substituted one for another without any appreciable change in the focus. We have seen that the relation of image to object size (i.e., the magnification), when a real image is formed, is expressed by the distance of the image from the back focal plane divided by the focus. In other words, the distance from the optical center of the objective to the plane where its image is formed must be divided into two components, that to the back focal plane of the objective and the distance from that point to the image plane. If no attention were paid to making objectives parfocal, the great difference between the back focal distance of a two-inch object and a $\frac{1}{2}$ could be compensated for in the barrel length of the objective, but with parfocal lenses the distance from the bottom of the tube to the object must always remain the same. The barrel length must in all cases be such that the front lens will be at its exact working distance from the cover glass (of ideal thickness) without altering the position of the end of the tube.

Under this condition we can no longer accurately compute the initial magnification of an objective on the basis of dividing its focal length into the mechanical tube length. It must be divided instead into the *optical tube length*, which is the distance from the back principal focus of the objective to the lower principal focus of the eyepiece. Unfortunately, the optical tube length varies for every type of objective. As its determination by experimental means is somewhat involved, computing the initial magnification of older lenses, marked only with the equivalent focus in inches or millimeters, cannot be done with precision.

Fortunately, however, an approximation of the magnification can be arrived at, sufficiently accurate for most purposes. In low-power objectives the back focal plane lies nearer the eyepiece, hence the optical tube length is *shorter* than the mechanical tube length. In

high-power lenses it lies closer to the objective, and the optical tube length is *longer* than the mechanical.

An average of the lenses of several large manufacturers reveals that their optical tube length for intermediate lenses (16 mm.) does not vary materially from the mechanical tube length. In these lenses the actual magnification varies only 0 to 3% from that obtained by dividing the mechanical tube length for which the lens is computed by the equivalent focus of the objectives. The error on the shorter-focus objectives when this is done increases until the average for a 40 mm. lens is about 30% too high. On the other hand, high-power lenses (2 mm.) will be rated about 10% too low if their magnification be computed by this means. From this it is evident that if an approximation of the magnification (at least the order of magnitude) of lenses marked only with this focal length be required, it can be obtained by dividing the focal length into the mechanical tube length employed, reducing this value by 15 to 30% for low-power lenses and increasing it by 5 to 10% for high-power lenses.

As a matter of fact, during the transitional period, manufacturers in many instances followed a somewhat similar procedure, even in engraving the magnifications on the objectives. For example, Bausch and Lomb, in the 1919 edition of their catalogue, give the magnifications of their apochromatic series as follows: 16 mm., 10x; 8 mm., 20x; 4 mm., 40x; 3 mm., 53x; 2 mm., 80x; or, in other words, 160 divided by the focal length. Undoubtedly, in such cases, both the focal lengths and magnifications are nominal, being approximations only. Present-day practice is to give accurate data on both focal length and initial magnification.

Practical experience has demonstrated that there is a limit to the degree of magnification which can be contributed by the eyepiece; ordinarily about 20x is the upper limit recommended by manufacturers.* Mechanical design sets a normal low limit of 4x or 5x, hence a battery of eyepieces between 5x and 20x, preferably with a little overlapping, is all that is necessary.

This limitation involves the establishment of a series of objectives sufficiently extensive to yield, in combination with the various eyepieces, almost any degree of total magnification from 10x to the upper

*25x and 30x are supplied on special order by some manufacturers.

limit. (This latter is, for visual purposes, set by an objective with an initial magnification of $120\times$ and a $30\times$ eyepiece, making $3600\times$.)

Each manufacturer's series varies somewhat, but the usual order is $3\times$, $5\times$, $8\times$, $10\times$, $20\times$, $40\times$, $60\times$, $90\times$, $120\times$.

The following table gives the magnifications resulting when these are used with the ordinary series of oculars:

OBJECTIVES	OCULARS								
	$5\times$	$7.5\times$	$10\times$	$12.5\times$	$15\times$	$17.5\times$	$20\times$	$25\times$	$30\times$
$3\times$	15	22	30	37	45	52	60	75	90
$5\times$	25	37	50	62	75	87	100	125	150
$8\times$	40	60	80	100	120	140	160	200	240
$10\times$	50	75	100	125	150	175	200	250	300
$20\times$	100	150	200	250	300	350	400	500	600
$40\times$	200	300	400	500	600	700	800	1200	1200
$60\times$	300	450	600	750	900	1050	1200	1500	1800
$90\times$	450	675	900	1125	1350	1575	1800	2250	2700
$120\times$	600	900	1200	1500	1800	2100	2400	3000	3600

A study of this table shows that identical, or nearly identical, magnifications can be obtained with several different combinations. For instance, $100\times$ is given by a $20\times$ objective and $5\times$ ocular, a $10\times$ and $10\times$, and $8\times$ and $12.5\times$ and a $5\times$ and $20\times$.

This may seem to imply a needless duplication of equipment, but this is not the case, for, as will be seen later, the results with each combination are different in spite of the magnifications being the same. Different conditions call for these different set-ups, and therefore a microscopist should know the optically different results produced and what combinations to use in order to secure the best results.

Mechanical Design of Objectives

Typical low, medium and high-power objectives are shown in Figures 22 and 23. Low-power lenses are relatively simple in their optical construction; in some cases they consist of but a single doublet lens. As the powers go higher, however, more components must be added and the front lens becomes increasingly smaller. Thus the ultimate power, with the maximum of correction, may have as many as ten or twelve separate lenses, all different, with a hemispherical (or even hyperhemispherical) front lens about the diameter of a period in this text. When it is realized that the glass of which each unit is

composed must be very accurately controlled as to refractive index and dispersion; the curved surfaces accurately ground and polished to a degree of accuracy specified in terms of a small fraction of light-wave length; the thickness and diameter of each lens be exactly right;

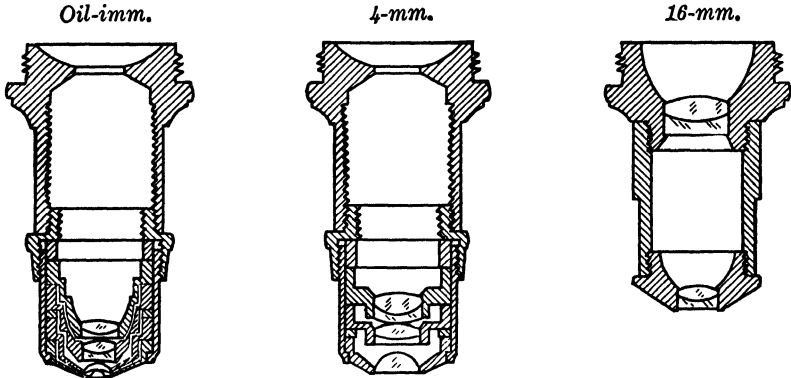

FIG. 22. Objectives of the Older, External Thread Form, in Cross-section

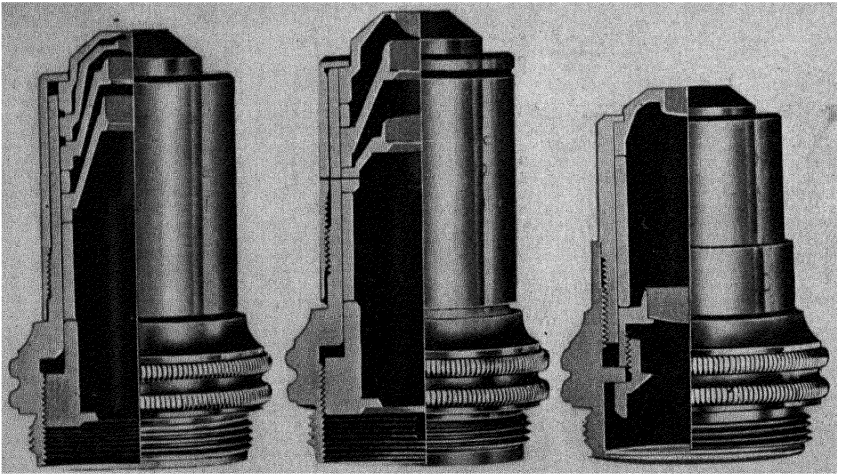

FIG. 23. Objectives of the Modern Internal Barrel Construction, in Cross-section

(Courtesy of Bausch and Lomb Optical Co.)

and the entire set axially mounted in the proper relation to each other, it is no wonder that such an objective may cost well over a hundred dollars. The low-power simple doublet, on the other hand, may cost only four or five dollars.

Optical Characteristics and Nomenclature

These various lenses possess several additional optical characteristics which have not as yet been touched upon, but which play an important part in their use. We saw, for instance, that a simple lens has a focal point or *focus*, when its corresponding conjugate focus is infinity. In the case of an objective — whether it consist of two lenses in doublet form, or ten or twelve — where the increase in number is for the purpose of correcting the various aberrations, the entire lot must be conceived of as possessing a single focus, called the *equivalent focus*. That is, the entire set of lens components has the magnifying power of a single lens of the designated focal length.

In addition to *equivalent focus*, two other terms identify additional lens characteristics which play important parts in microscopical and optical sciences. One of these is the ratio existing between the focal distance and the diameter of the lens, generally expressed fractionally. For example, $f/4.5$ means that the diameter of the lens equals the focal length (f) divided by 4.5. Thus a lens with a focal length of 4.5 inches would be 1" in diameter, a 9" would be 2" in diameter, and so on. This ratio is more commonly used in photography than in strictly microscopical work, as it is an expression of the *speed* of the lens; the light transmitted by lenses of equal focus is in proportion to the square of their diameters. It is, however, often met with in microscopical apparatus, particularly in connection with lenses designed for low-power photomicrography.

Angular Aperture

The other term, closely related to the f value, is more strictly a microscopical one, for, as we shall see later, the amount of light passing through a lens (so important in its relation to the exposure time of photography) is not the criterion of value in the formation of a magnified image. For this the *degree of resolution* is of prime importance. This can be expressed in a formula based upon the maximum angle of light entering the lens from the front focal point. This angle between the marginal rays of a lens is known as the *angular aperture*.

Numerical Aperture

In the early days of the microscope it was customary to express the working characteristics of a lens in terms of its angular aperture. This meant that the angular aperture of an immersion lens, expressed in terms of an air-angle equivalent, might exceed 180° — apparently an absurdity, but nevertheless true. Abbe showed, however, that the angular aperture was not the true criterion by which an objective should be rated; that the relative performance of any type of objective, dry or immersion, could be expressed directly in terms of the sine of one-half the angular aperture multiplied by the refractive index of the medium between the object glass and the front lens of the objective. The value so derived he designated the *numerical aperture* (N.A.). As long as the medium is air, as for dry lenses, it does not affect the formula, for the refractive index of air is 1.00. Hence the numerical aperture of dry lenses could be expressed simply as the sine of one-half the angular aperture. But to provide a uniform formula which applies equally well to both dry and immersion lenses necessitates the inclusion of the refractive index of the space medium in the formula.

The formula is written:

$$\text{N.A.} = n \sin u,$$

N.A. meaning numerical aperture, n the refractive index of the medium between the front lens and the object, for which the lens is computed, and u the angle which the outermost marginal ray entering the front lens makes with the optic axis (i.e., one-half the total angular aperture). As the limiting angle is 90° , of which the sine is 1.00, the sine of u will always be less than unity. When the medium is air, n is always 1.00. Therefore the N.A. of a dry lens must be less than 1.00. When thickened cedar oil is used as an immersion fluid, n in the formula becomes 1.515. Hence the N.A. of immersion lenses can and usually does exceed 1.00.

Relation of Numerical Aperture to Magnification and Resolution

Lenses are ordinarily designed so that the N.A. increases with the magnification. There are two reasons for this. One is that increased light is needed for proper illumination of the field as the magnifica-

tion goes up, for with a fixed amount of light per unit of area, the light intensity decreases inversely as the square of the diameters; that is, to increase the magnification from $100\times$ to $200\times$ using the same objective, the light would be decreased to one-fourth the intensity. But the light increases as the square of the N.A. Consequently, to double the latter will give a four times increase in the light. Hence if, in increasing the magnification from $100\times$ to $200\times$, we do it by using a lens which, in addition to having a higher initial magnification, also has an N.A. of twice the previous one, there will be no difference in the light intensity.

But the more important reason is this: When higher powers are required, it is usually because we wish to see more detail, that is, to resolve or separate parts which are not evident at a lower magnification. For every N.A. there is a limit beyond which further magnification will not give additional detail; if we go beyond this point we get only what is called *empty magnification*. The ability to resolve increases in direct ratio to an increase in N.A.

If a certain lens will resolve a maximum of 5,000 lines or dots per inch so that each line or dot appears in the microscope as separate and distinct from the others, a lens with double the N.A. will resolve 10,000 and one with an N.A. ten times as large will resolve 50,000 lines per inch. This direct relationship is a very important one to the microscopist, for it enables him to know just what to expect of every lens.

Other conditions (i.e., the quality of the lens, etc.) being ideal and equal, only two factors enter into the degree of resolution possible. These are the numerical aperture of the lens and the wave length of the light used to illuminate the specimen.

With an illuminating cone equal to that of the objective the formula governing resolution is expressed as $R = \frac{\lambda}{2 \text{ N.A.}}$ where R is the distance between two points in the object which can be separated so as to be evident as separate points, and λ is the wave length of the light employed. With any lens, increased resolution can be obtained by using light of a shorter wave length, provided that the lens is equally well corrected for the shorter region.

It can be shown mathematically that with white light as the source

of illumination the theoretical upper limit of magnification — where an achromat lens gives its utmost in resolution, and beyond which only empty magnification results — is roughly 1,000 times the numerical aperture. In other words, even an oil-immersion lens of 1.30 N.A. would reach its limit at 1300 \times . But this limit, a theoretical one, is not a practical one, for the ordinary eye will benefit materially by at least a two-times enlargement even when it is only empty magnification.

The same may be said of the image produced by a first-class objective; it can stand considerable further enlargement, certainly at least two times, before breaking down. High-quality lenses, especially apochromatics, will stand up to three times the theoretical magnification and apparently show increased detail, especially when used for photomicrographic purposes.

Depth of Focus

The numerical aperture also has a direct bearing on several other characteristics of a lens, one of which often enters into microscopical problems in everyday experience. This is what is known as the *depth of focus*. It is analogous to what is encountered in ordinary photography, where two extremes are possible: to take a picture in which everything, from a few feet away up to the mountains in the background, appears equally sharp, or to take one where only a near-by object is in perfect focus, all other objects, both nearer and farther away, being indistinct and out of focus. As is well known, these results are achieved by using, in the first case, a small diaphragm opening, and in the second, a wide-open lens carefully focused on the desired object. In the same way an objective having a narrow angular aperture (i.e., a low N.A.), corresponding to the small diaphragm opening of the camera lens, gives a considerable depth of focus. That is, portions of a transparent object lying either above or below the theoretical plane of perfect focus are more or less clearly delineated. Or, in the case of opaque objects viewed with reflected light from above, various portions of an uneven surface can be seen in focus simultaneously. Naturally, there are many cases where such a condition is ideal for examination, as it obviates the need for focus-

ing up and down to study the various parts in their relation to each other.

As the numerical aperture of a lens is increased, the depth of focus decreases until finally, with high-power immersion objectives of high aperture, there is no appreciable depth whatever, the focus being almost a true optical plane. Indeed, the plane is so sharp that portions of the object lying immediately above or below, to the extent of only a micron, are completely invisible.

From this another generalization about a lens's characteristics can be stated: The depth of focus is inversely proportional to the numerical aperture.

Working Distance

Then again the numerical aperture is somewhat related to another characteristic of objectives, what is known as the *working distance*. Naturally, as the equivalent focus of an objective is shortened, the distance between the front lens and the object decreases. A low-power lens may have a working distance of several inches, but as we go to the high powers we find that the objective approaches the object until it almost touches. With opaque objects, especially metals, it is customary to work with uncovered surfaces, that is, with nothing except the optical medium, air or oil, between the object and the front lens of the objective. The front lens of the objective could practically touch the object, if necessary, to obtain the proper focus. With transparent objects, however, this is not so, for they are usually covered with a cover glass. Therefore the working distance between the lens and object must be sufficient to focus on the latter through the cover. When dealing with these high-power lenses we find that for a given equivalent focus, an increase in the N.A. involves a decrease in the working distance. Often one encounters a prepared microscopical slide which cannot be focused upon with a high N.A. immersion lens because the cover glass is too thick. The only remedy is to substitute a lens of longer working distance. The same condition obtains when we use a standard counting chamber or a quartz dark field chamber where the cover glass must possess a sufficient thickness to resist deformation. For these latter purposes the manufacturers supply lenses of the same equivalent focus but of lower numerical aperture.

Optical effect of Cover Glass over Object

The fact that cover glasses are employed for transparent objects introduces another problem for the optician to solve in the computation of his objectives and one with which every microscopist should be familiar. This problem is that, as the cover lies between the object and the objective and possesses a positive thickness, it becomes part of the optical system and in effect is the first element of the objective.

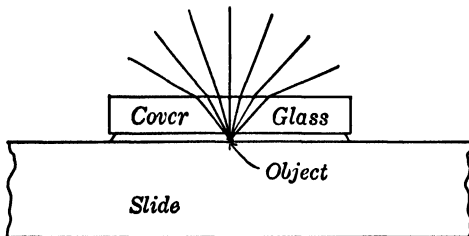

FIG. 24. Spherical Aberration Due to Cover Glass

This will be apparent from Figure 24, which shows the divergence of the rays from a point in the object as they pass out of the cover glass into air. The effect is identical with the spherical aberration present in an uncorrected lens, where the marginal rays

come to a focus closer to the lens than the central ones. The thicker the glass, the more marked is the effect. Its thickness is therefore of prime importance; in order to give perfect results, all the remaining portions of the system (i.e., the objective as a unit) must be computed on the basis of a definite thickness of cover glass. This thickness has been established by most manufacturers at .17 to .18 mm. With low-power lenses the cover-glass thickness is not important. In fact, below 16 mm. ($\frac{2}{3}$ ") lenses, cover glass can be quite thick or even omitted altogether. However, when a high-power dry lens of 4 mm. ($\frac{1}{3}$ ") is used a difference of .01 mm. ($\frac{1}{2500}$ ") in the cover-glass thickness affects the resulting image materially. For this reason the manufacturers supply, at an additional cost, these high-power dry lenses with correction collars, the function of which is to alter the position of the lens components to compensate for variations in the cover-glass thickness. The correct position for each thickness is engraved on the rotatable collar. In the case of the 4 mm. apochromat with an N.A. of .95, the lens is not supplied in any form but the correction-collar type, as its performance is of a very low order unless the correction is made for the actual cover glass employed. Where correction collars are not provided and it is obvious that a lens of known

high quality is performing poorly because of improper thickness of cover glass, partial correction can be obtained by altering the position of the draw tube, shortening it if the cover is too thick and extending it to compensate for a thin cover. Unfortunately, this method is far from ideal, for it requires a change in the tube length of approximately 10 mm. for each .01 mm. departure from the ideal cover thickness. Not much adjustment, therefore, is available. Moreover, the common fault is too thick covers, rather than too thin, and usually not much shortening of the tube is possible.

Effect of Cover Glass with Immersion Objectives

In respect to cover-glass thickness, immersion lenses have a material advantage over high-power dry lenses, for the oil employed between the front lens and the cover glass is of substantially the same refractive index and dispersion as the glass. All the space, therefore, between the object and the objective is filled with a homogeneous medium of the proper index even if no cover glass is present. It must, of course, be recognized that this may be done only if the lens is designed to be used with oil. It is not possible to use oil with a dry lens, even if the latter works so close to the cover glass that an oil contact is feasible. The difference between the two types of lenses, as well as the manner in which the oil increases the aperture, is demonstrated in Figure 25.

Whenever a lens designed for oil immersion is employed oil must be used between the objective and cover glass. In such cases the effective numerical aperture is secured only when the object is mounted in balsam or other medium with a refractive index at least as high as the cover glass.

If the object be mounted dry, so that air is present between it and the cover in the path of the rays, the effective N.A. is only 1.00, even with an immersion lens of much higher N.A.

We have mentioned the fact that no cover glass is employed with opaque objects such as metals. It will be evident that the problem here involves a double series of objectives extending from the intermediate powers to the high dry lenses, in order to meet both conditions. Removing the cover glass is not necessary when immersion lenses are used, but it has been found that all lenses perform better

when used with the vertical illuminator necessary for metallurgical work, with the illuminator located as closely as possible to the back lens of the objective. For this reason an entire series, including the oil-immersion lenses, has been made available in short mounts for metallurgical work. This series usually is computed to work with a longer tube than the standard because of the necessity of employing a vertical illuminator above the objectives. Those who require both

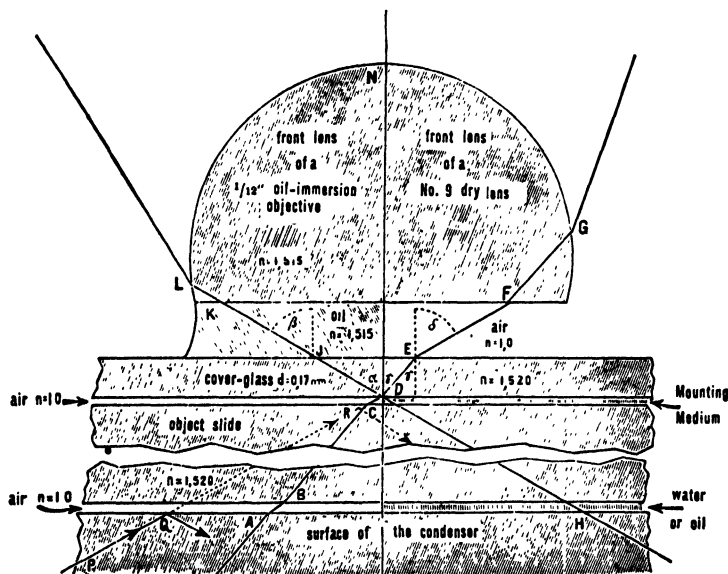

FIG. 25. Paths of Light Rays in Dry and Immersion Objectives. (After Leitz)

series for their work, but who are not able to afford duplication of the immersion lenses, may purchase the latter in the short mount form, together with an extension collar which converts it into the standard long mount type. One should then be sure to use the correct tube length by properly adjusting the draw tube. If the extension collar is not used, the proper tube length can also be secured by means of the draw tube. Such procedure is false economy, however, for any who can possibly afford both series of objectives.

Figure 26 shows a comparison of long and short mount objectives. The average optical data applying to lenses of the former series, of

interest to the microscopist, are covered in the table below. The product of each manufacturer will vary somewhat from the data herein given, depending upon variations in the formula upon which the lenses are computed and maker's individual ideas of what characteristics to favor at the expense of others.

It is not feasible to give similar information on short mount objectives, corrected for use without cover glass, as the tube lengths adopted by the various manufacturers are not uniform. The important variable is the initial magnification. The

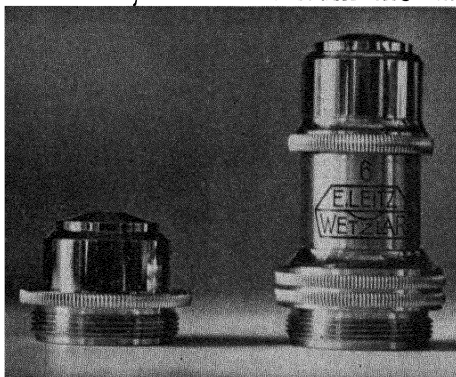

FIG. 26. Long and Short Mount Objectives with Lens of the Same Power

(Courtesy of E. Leitz)

Equivalent focus		Type	N. A.	Approx. Working initial mag. distance*	
mm.	inches			160 t.l.	in mm.
75	3	Dry achromat	.08	2x	60
50	2	Dry achromat	.08	3x	45
32	1½	Dry achromat	.10	5x	30
25	1	Dry achromat	.12	7x	18
16	⅝	Dry achromat	.25	10x	8
16	⅝	Dry apochromat	.30	10x	5
8	¼	Dry achromat	.50	20x	2
8	¼	Dry apochromat	.65	20x	1
4	⅛	Dry achromat	.65	40x	.55
4	⅛	Dry achromat	.85	40x	.30
4	⅛	Dry apochromat	.95	40x	.20
3	⅙	Dry achromat	.85	60x	.20
3	⅙	Dry apochromat	.95	60x	.15
3	⅙	Oil imm. apochromat	1.30	60x	.15
3	⅙	Oil imm. apochromat	1.40	60x	.13
2	⅙	Oil imm. achromat	1.25	90x	.11
2	⅙	Oil imm. apochromat	1.30	90x	.08
2	⅙	Oil imm. apochromat	1.40	90x	.05
1.5	⅙	Oil imm. apochromat	1.30	120x	.08

*Working distance is the distance between the lowest part of the lens mount and the cover glass when the microscope is focused on a preparation covered with a cover of .17-.18 mm. in thickness.

approximate magnification in each case can be determined by multiplying the magnification for a tube length of 160 mm. by

Tube length for short mount objectives

160

Bausch and Lomb have two standard short mount tube lengths, 165 mm. and 215 mm. Leitz is 215 mm. and Zeiss 190 mm.

Eyepieces (a) Huygenian

Eyepieces (or oculars, as they are interchangeably called) are of much simpler optical construction than objectives. The form in most general use is a negative combination, originally designed by the Dutch astronomer Huygens for astronomical purposes and named for him *Huygenian*. It consists of two plano-convex lenses, separated the length of the eyepiece and mounted with the flat surfaces on the top. Between the lenses, at the approximate focus of the top, or eye, lens is a diaphragm which serves to limit the field of view.

This type of construction lends itself to the use of cross-hairs, pointer or micrometer rulings, etc., for when these are mounted in the plane of the diaphragm they are in focus with the microscopical image, being superimposed upon it. When intended especially for this purpose the top lens is usually mounted in a sliding sleeve, so as to obtain sharp focus on the diaphragm plane; this form is known as a micrometer eyepiece.

In the Huygenian eyepiece, the low powers are the longest; as the magnification increases, the length of the eyepiece decreases. This fact is of considerable help in determining the approximate magnification in old models where the eyepieces were either not marked at all or marked only with an arbitrary series of numbers, 1, 2, 3, etc.

Zeiss old series eyepieces, which are comparable with those of other makes, had the following dimensions and characteristics:

Old notation	1	2	3	4	5
Length of barrel	2"	1 $\frac{7}{8}$ "	1 $\frac{1}{2}$ "	1 $\frac{1}{4}$ "	1"
Focal length in mm.	63	50	36	25	17
Magnification	4x	5x	7x	10x	15x

If we measure the overall length of the barrel of an unmarked eyepiece, or one with a meaningless designation, we may ascertain its approximate magnification by using the above table.

(b) Ramsden

The positive or *Ramsden* type of eyepiece in its simplest form also consists of two plano-convex lenses, but the bottom lens has its convex surface uppermost, and it is located closer to the top lens, so that the two function together as a single magnifier with the diaphragm placed beneath the field lens. The position of the diaphragm and

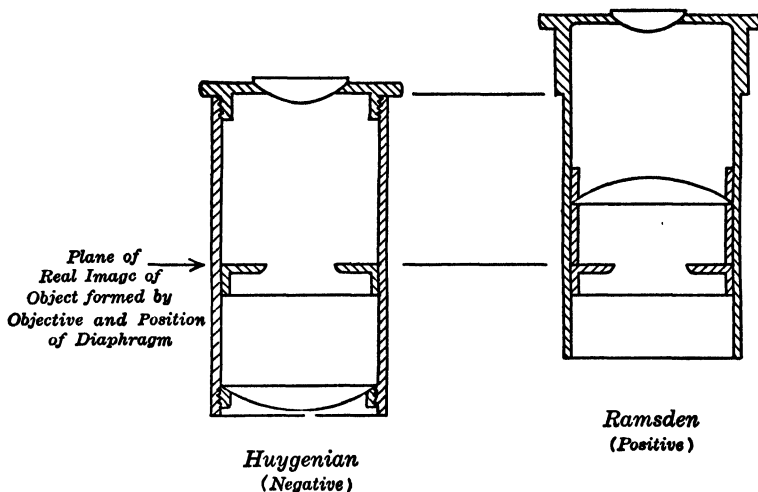

FIG. 27. Huygenian and Ramsden Eyepieces, in Cross-section

the fact that the Ramsden eyepiece can be used as a magnifier while the Huygenian (being a negative combination) cannot, suffices to tell the two types apart. Figure 27 illustrates the difference in the construction of the two types.

(c) Compensating

Compensating eyepieces are over-corrected combinations designed primarily for use in conjunction with apochromatic objectives, so as to complete the correction necessary since the color images formed by the objectives are not the same size. They can be either the Huygenian or Ramsden form, depending on the magnification. Compensating eyepieces of both the positive and negative forms can also be furnished as micrometer oculars with focusing adjustment.

Condenser

Although the objectives and eyepieces constitute the optical portion of the microscope proper, the instrument would not be of much value for high powers without the substage condenser. It is the function of the condenser to furnish a cone of light to the object which will properly match the numerical aperture of the objective in use.

The condenser in its simplest form is not, optically, as complex as an objective. It should, however, be visualized as an objective similar in magnification and numerical aperture to the objective, mounted upside down, underneath the object. Light passes through it in a reverse direction, concentrates in a conical form, and comes to a focus directly on the object.

The simplest forms of condenser ordinarily supplied as standard equipment* are known as the Abbe two-lens forms. They have a maximum N.A. of 1.20, which is secured by oiling the condenser to the bottom of the slide. Such oiling is always necessary with all condensers having an N.A. in excess of 1.00, if the full illumination cone is desired. Otherwise the air space limits the effective cone of illumination to N.A. 1.00. However, for a large part of ordinary work with immersion objectives it is not necessary to have an illuminating cone larger than N.A. 1.00.

The Abbe three-lens condenser has a numerical aperture of 1.40. Neither of the Abbe types is corrected for spherical or chromatic aberration.

In addition to the simple Abbe condensers, most manufacturers supply, at a considerable increase in price, types which are corrected. Those in which only spherical aberration has been eliminated, are known as aplanatic condensers. Those with both spherical and chromatic correction are referred to as achromatic, or by trade names.

These condensers of high N.A. are designed primarily for work with high-power objectives. When used with those of 16 mm. focus and lower, they are subject to one serious drawback: For critical illumination (which is discussed in Chapter 4) they do not fill the field of view with even illumination. Generally, the manufacturers

*For low-power photomicrographic work single-lens condensers are supplied. These are often designated spectacle-lens condensers.

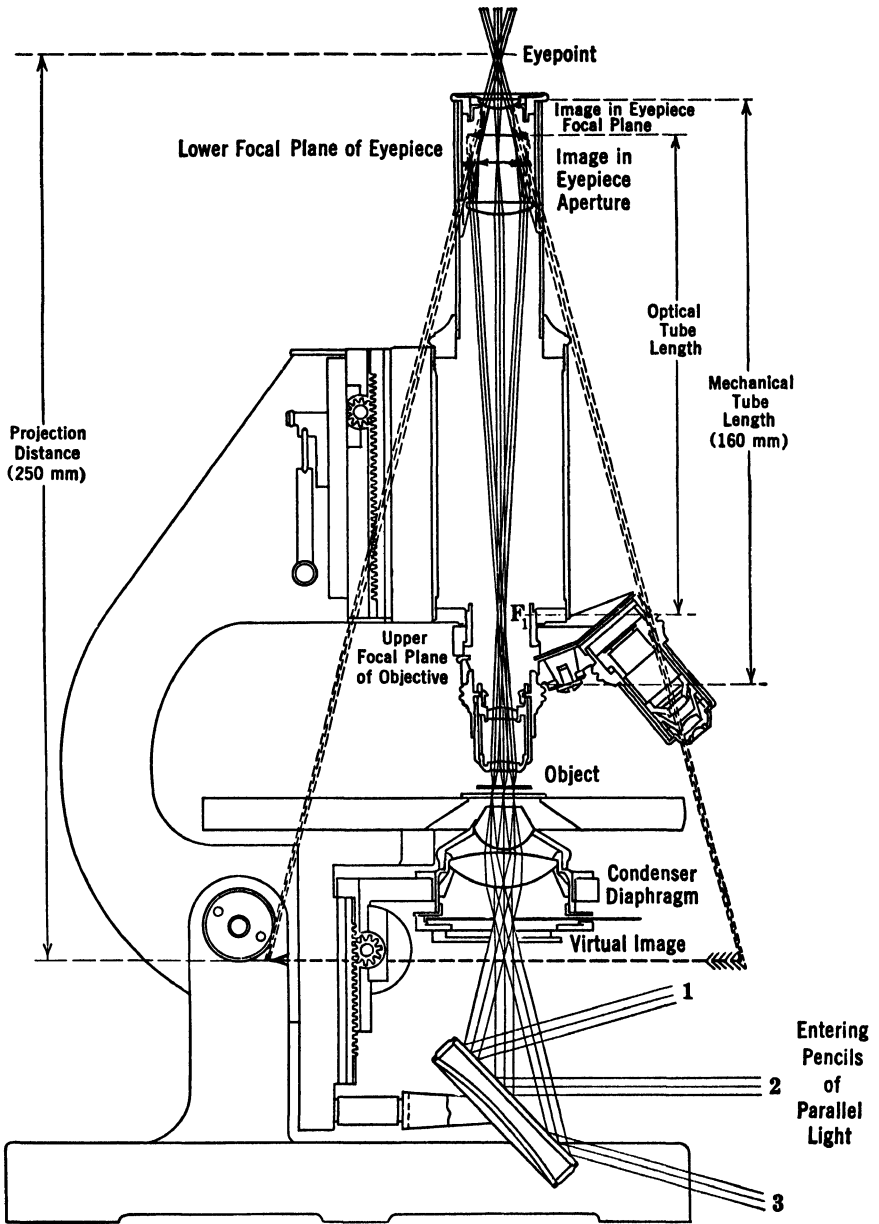

FIG. 28. Path of Light Rays in a Compound Microscope

(Courtesy of Bausch and Lomb Optical Co.)

have provided for this by making the top lens removable, by unscrewing or other means. This gives a longer focus and lower aperture condenser, and more nearly meets the characteristics of the low-power objectives.

The facilities provided for focusing the condenser are primarily intended for bringing it into the exact position of focus for critical light with slides of varying thickness. A much wider range of motion is available, however, so that for work where critical illumination is not required, the entire field can be evenly illuminated.

As the condenser is a vital part of the optical system of the compound microscope, we should understand just what happens to the light from the time it impinges upon the mirror until the virtual image is formed in the eye. Figure 28 aids in visualizing this by showing the path of the limiting rays and the position of the virtual image.

When one examines a microscope, especially the research type, for the first time, one may feel that there is a superabundance of mechanical contrivances in addition to the optics which have been described. But every adjustment, every motion, every device provided, is the outgrowth of years of use of the instrument by scientists and amateurs, and each is there because experience has demonstrated that it is desirable. A thorough knowledge of the fundamental optics of the microscope will, therefore, often reveal the reason for certain mechanical features.

Chapter 3

MODERN INSTRUMENTS

Trends in microscope design in recent years have been of such radical nature as to necessitate a clear statement of the sense in which we employ the qualifying adjective "modern." It is necessary also to divide modern instruments into two groups: (1) those which are functionally the equal of the very latest designs of the same class, although of older vintage, and (2) instruments of the very latest type of manufacture. In general, microscopes — especially the more elaborate models — manufactured since the turn of the twentieth century, should be considered modern. Indeed, there are still in use many fine instruments much older than this, but qualified to be called modern even though they bear inevitable marks of belonging to an earlier generation.

The changes which have taken place in the mechanical design of conventional models during the last forty years are sufficiently general in scope to serve as guides in determining the approximate age of a given instrument. Those which appreciably affect the interchangeability of parts are the standardization of the 23 mm. diameter eyepiece and the short tube length. If an instrument has the large diameter eyepiece ($32\frac{1}{4}$ mm.) and long tube length* it cannot be classed as modern, although it may be quite serviceable. Microscopes with short tubes but provided with the 32 mm. eyepieces can easily be equipped with an adapter to accommodate the standard 23 mm. type, but long tube instruments cannot be used with present-day objectives without sacrificing quality of image.

The finish applied to an instrument is another indication of the period of manufacture. For many years polished or grained brass, highly lacquered, was standard for all parts, including the base.

*This statement, of course, has no bearing on the use of 30 mm. diameter eyepieces and longer tube lengths such as those employed with modern instruments of the petrographic and metallurgical types.

Cheap models with cast-iron bases had a black japanned finish applied to the latter. Gradual realization that black japan is far more durable in withstanding deterioration and accidental contact with various reagents, caused its adoption even on solid brass bases. This was followed, with some few exceptions, by a complete black finish for all parts of the stand except trimmings and adjusting screws.

Other marks indicative of the age of an instrument are the type of fine adjustment which has changed from a vertically acting screw on the arm back of the rack and pinion to a side adjustment having a motion in the same direction as the coarse adjustment; and the adoption of larger diameter tubes on the more elaborate models so as to accommodate low-power lenses for photographic purposes. The side fine adjustment has become almost universal in its application, but the large diameter tube is still limited to the more elaborate models. The nosepiece is still another part of the instrument that has undergone a modification for the better in design. Older models are often found with the dust guard covering the extra objectives in the stationary position only. As the objectives are rotated into position they are momentarily uncovered, thus allowing dust to fall into them. Those manufactured in the last twenty-five years have been of the circular type so that at no time are they uncovered.

An improvement which has been gradually introduced by all manufacturers, but which is not so readily apparent, is an increase in the weight of the foot, or an equivalent redistribution of the total weight, so as to give greater stability in the horizontal and inclined positions. This lack of stability was a serious defect in many earlier models.

When a stand bears the name of the manufacturer, it is often a guide as to the instrument's age, especially since some bear names of firms no longer in business. A still better guide is the serial number now almost universally applied.

There are also certain clues pertaining to objectives and oculars which serve as a guide to their age. Of course, as with the stand itself, the manufacturer's name and serial number are among these, but the general design and markings are equally valuable indicators. Older objectives of English and American manufacture were universally marked with the equivalent focus in inches or fractions of an inch. The gradual introduction of the metric system for scien-

tific purposes resulted in its adoption for designating the equivalent focus, hence a $\frac{3}{8}$ " objective became a 16 mm., a $\frac{1}{8}$ " a 4 mm., and so on. But lately even this practice has been changed to show the initial magnification instead. Thus a 16 mm. is now marked 10x, and a 4 mm. becomes a 40x.

In the mechanical construction of the objectives, a radical change has lately taken place, which marks a superior type of design. Older-style lenses were constructed so as to permit the various components to be unscrewed from each other and knurled edges were provided for this purpose. This design is open to two objections; first, it makes it possible for *anyone* to take the lens apart, even though he may know nothing of its construction or the ease with which it can be damaged or improperly reassembled. In the second place, this construction makes it difficult and expensive properly to center the various components. The common practice* at present is to mount the individual components in separate sleeves fitting closely into each other and so assembled that they cannot be unscrewed from the outside. This results in a plain cylindrical barrel, easily kept clean. This type of barrel, combined with a chromium or rhodium plated finish instead of a lacquered brass, is the last word in objective design.

Eyepieces of recent manufacture, as in the case of objectives, have their magnification engraved upon them instead of an arbitrary numerical or alphabetical designation. This is a great convenience in determining the magnification employed, as it is necessary only to multiply the value marked on the objective by that on the eyepiece.

In this age of specialization, it is only to be expected that microscopes and associated equipment be provided to meet each individual type of service, hence we find manufacturers' catalogues subdivided into different classifications, models, and so on. Biological, Laboratory, Medical, Research, Chemical, Petrographic, Metallurgical, etc. Naturally, these designations raise many questions in the mind of prospective purchasers not previously trained in microscopy. Among these are: Why is it necessary to have different models for different purposes? How do the models differ from each other? Will one type of instrument serve for another purpose in a different

*Some manufacturers (e.g., Leitz) still prefer to retain the older form and take special steps to assure proper centering.

field? Must I have a separate instrument for each class of service? Are there not accessories which can be purchased so as to adapt one type of instrument to another purpose? — And many more of a similar nature.

A thorough understanding of the reasons for each design and the peculiarities in design necessitated by each type of service will often aid the user in making the proper selection of an instrument to suit his individual needs. Often the determination of which model is best suited to the purpose is left to a salesman, who, in spite of a sincere desire to help, is nevertheless handicapped by not knowing all the factors involved. Again, sometimes a salesman's desire to make a sale of a particular type of instrument may influence him to stress its advantages even though it may not by any means be the one most adapted to the work it is to perform. The best judge of which instrument to purchase is the one who is to use it, provided that he has an appreciation of what elements are involved in his problems as a whole, and what equipment is available to meet his needs.

It must be recognized that for the majority of purchasers price is an important factor. It is partly because of this that the manufacturers have developed the various types of stands. Two conditions control the cost of manufacture: simplicity of design (with a corresponding elimination of all nonessential features) and quantity production.

Students' Microscopes

Naturally the largest single demand for microscopes comes from schools and colleges, which order them by the dozen or even by the hundred. It is to meet this need that the simplest type of instrument* has been developed. It is known by various names — students' microscope, school microscope, laboratory microscope, workroom microscope, etc. A typical instrument of this class is shown in Figure 29.

One of the first questions invariably asked by the novice purchasing a moderately priced microscope, upon being shown such a stand is, "How much does it magnify?" It is taken for granted that the

*It is to be understood that we are not here considering the small, cheap, toy-like microscopes, mostly of foreign manufacture, which are available in many optical stores, but only high-quality instruments.

RESEARCH MICROSCOPES

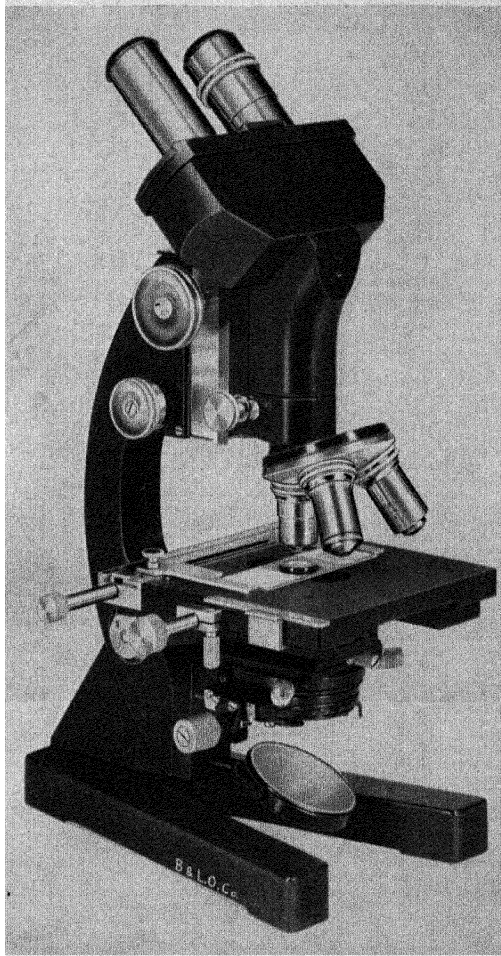

FIG. 31. Bausch and Lomb Research Model GGBE 1

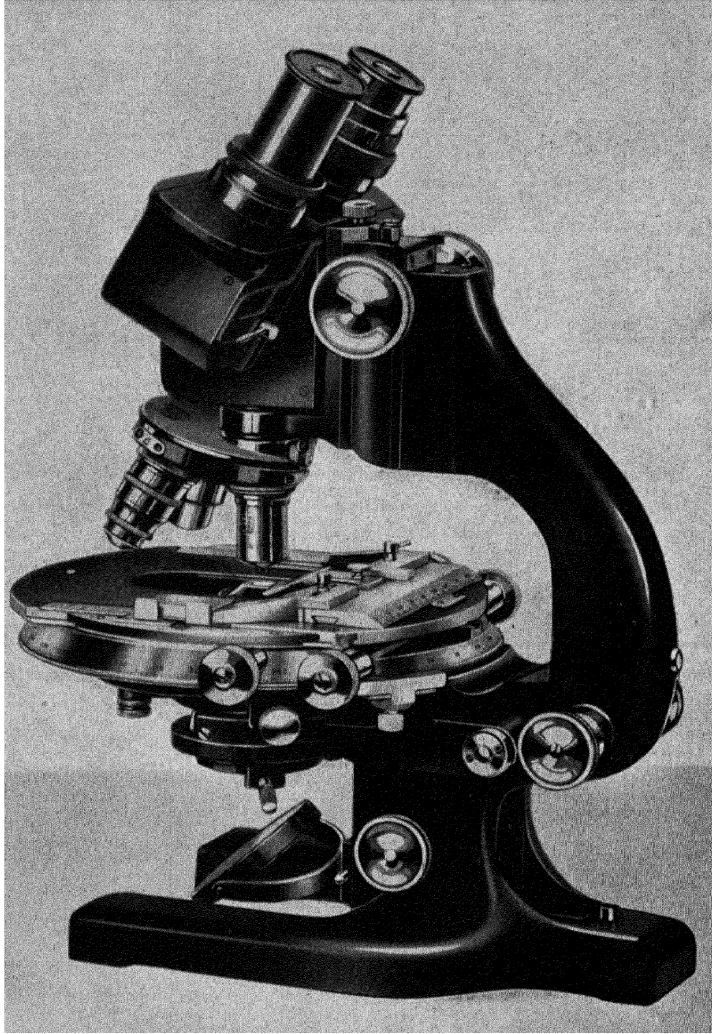

FIG. 32. Spencer Research Microscope Model No. 5

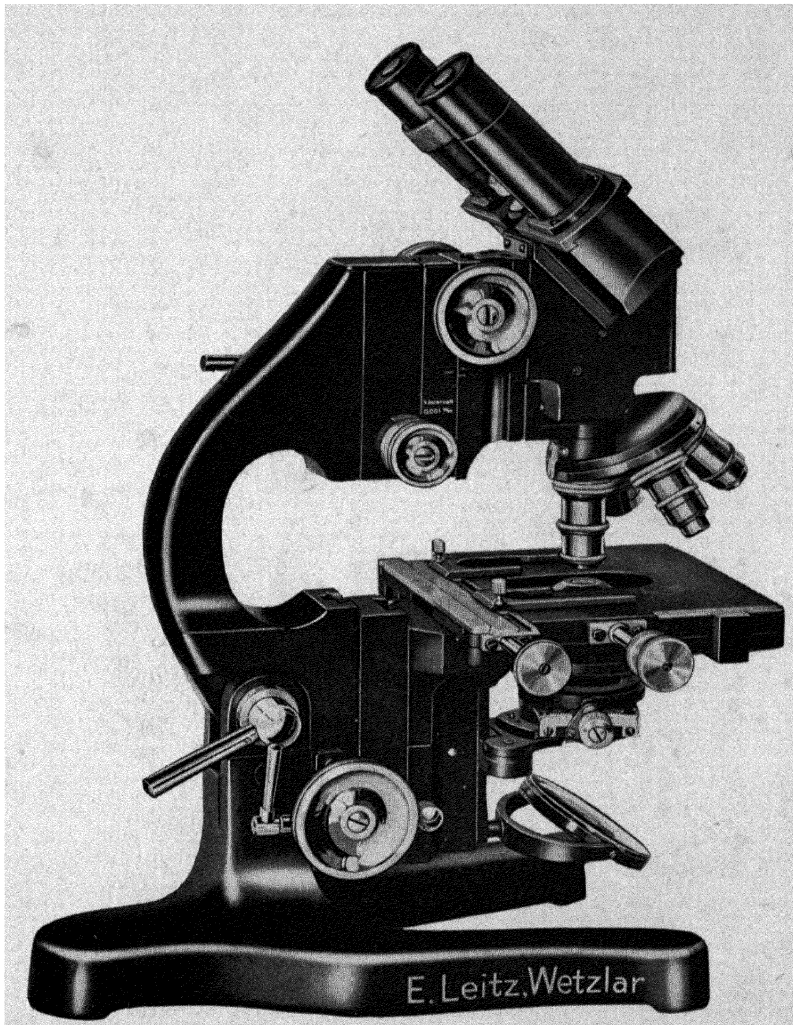

FIG. 33. Leitz Research Microscope Model *Unmic*

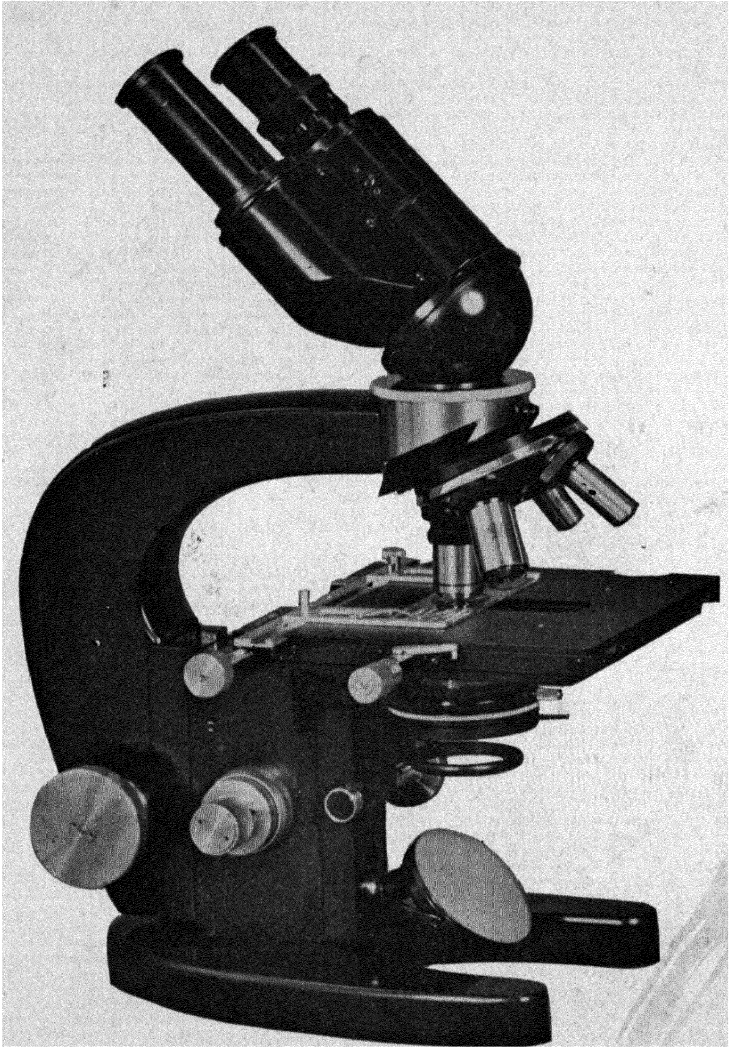

FIG. 34. Zeiss Research Microscope Model *Kaydu*

During the last few years a radical departure from the conventional design has been introduced by some manufacturers. This is practically a reversed type, with the supporting arm away from the observer instead of between him and the tube. Such instruments are shown in Figures 35 and 36. Although there is much to commend in this design, from both mechanical and operating standpoints, it is questionable whether it will ever supplant the older, conventional form.

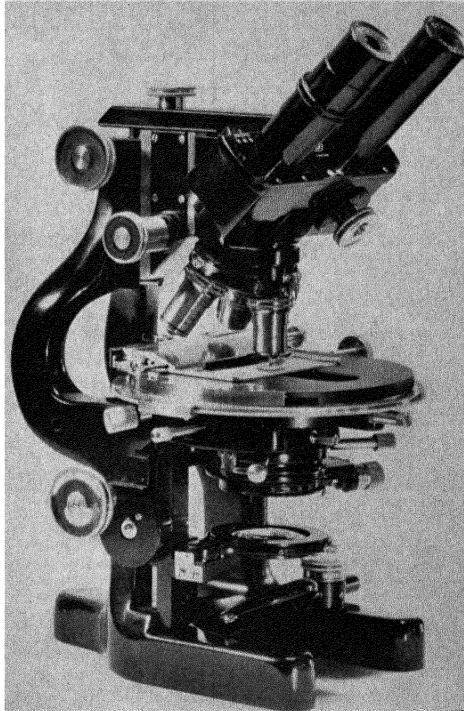

FIG. 35. Bausch and Lomb Reversed Type Microscope

This design is not so flexible for some kinds of work, its stage cannot be used in an inclined position, and it is not readily mounted interchangeably with other microscopes on the sole plates of horizontal photomicrographic outfits. Moreover, if one is accustomed to using several different microscopes for different purposes, one of this inverted form is awkward to manipulate, because of its radical differences in operation.

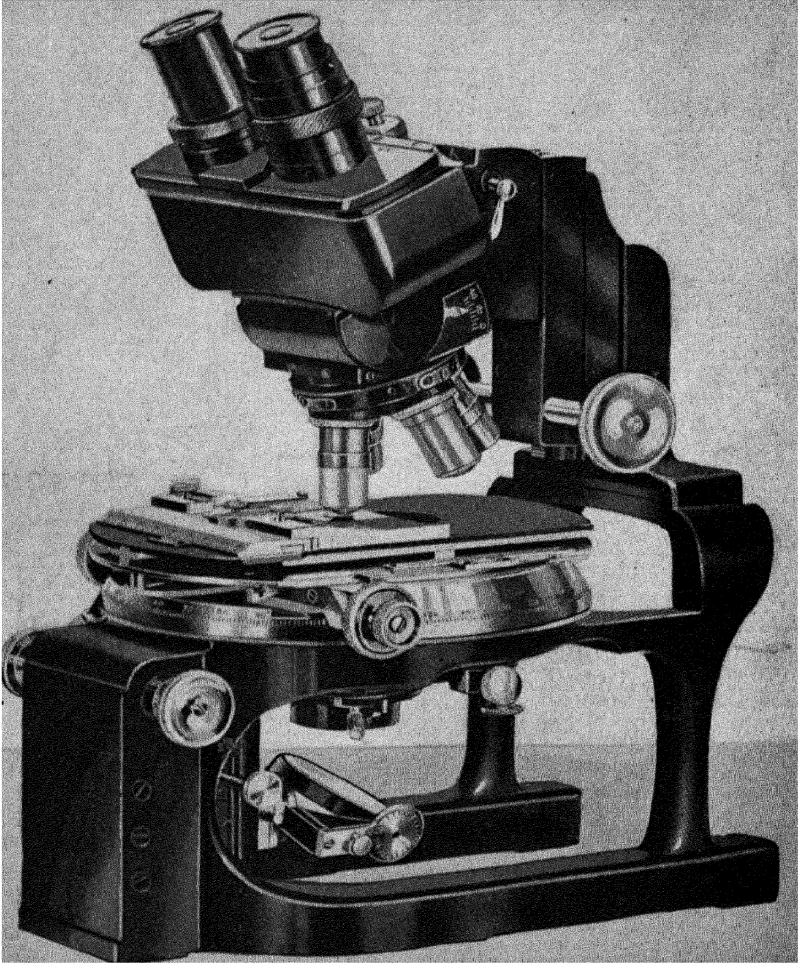

FIG. 36. Spencer Reversed Type Microscope

Obviously these elaborate instruments will do everything that the simpler models will, and much more; therefore cost is the largest determining factor in necessitating production of the less expensive stands. From the standpoint of service, however, it is poor policy to employ a research model in a laboratory where it will be subject to acid fumes, dust, etc., when a cheap stand will suffice. If a research model be required for some type of work under such conditions, it is cheap insurance for its continued satisfactory operation to purchase an additional simple stand and optics for rough usage and keep the good microscope where it will not be harmed.

Chemical and Petrographic Microscopes

Despite the elaborateness of research models, there are some kinds of work for which neither they nor the simplified stands are suited. Chief of these are chemical and petrographic examinations. It is not merely that these require polarized light equipment, for that is usually provided in the form of accessories for occasional use with almost any type of stand, but in order to work expeditiously in chemical microscopy and petrography, means must be provided for quick changes from plain to polarized light, conoscopic vision with Bertrand lens, and various other devices never required for general microscopical purposes.

In the petrographic stands (used also for chemical work) we find another series of models, extending from the simplest possible form up to very elaborate types, equal to the research models in the regular series. Present in all, however, are certain essentials which differentiate them from the corresponding stands of the ordinary type. These are: They must be fitted with a polarizer beneath the substage condenser and an analyzer in the tube above the objective, the latter capable of being quickly withdrawn or pushed into position as required; the stage must be circular, rotating and graduated for determining the degrees of rotation; a slot must be provided between the objective and analyzer for the insertion of compensators of various types, and another between the analyzer and eyepiece for the insertion of a Bertrand lens for observing interference figures; the top lens of the condenser must be capable of being quickly inserted in or withdrawn from the optic axis; the objectives must be provided

with some means for centering them relative to each other and must be specially selected for freedom from polarization; and the eyepieces must be provided with cross-hairs and capable of being inserted into the tube in a fixed position with relation to the vibration directions of the polarizing prisms.

All of these are essentials, but the ways in which they have been worked out for the various models differ materially. As with microscopes in the regular series, the more elaborate petrographic stands are larger, heavier, and capable of accommodating larger objects. Further, they are provided with more expensive polarizing prisms and more highly corrected condensing systems. Many additional adjustments are provided, such as rotation of the analyzer, with graduated circle; means for sliding the polarizer, as well as the analyzer, out of the optic axis; a centering Bertrand lens with iris diaphragm, mounted on a slide for quick insertion in the tube, and a separate rack and pinion for focusing the Bertrand lens for various oculars, and raising and lowering of the stage by rack and pinion. One of these elaborate petrographic models is shown in Figure 37.

In addition to this conventional form of stand, most manufacturers also provide models with synchronic rotation of the polarizer and analyzer. In the former, the specimen under examination is rotated with reference to the vibration directions of the prisms through rotation of the stage; in the latter, the specimen can remain stationary and the same result be accomplished by simultaneous rotation of the polarizer and analyzer, which are coupled together for this purpose by bars working around the stage. Such a stand is shown in Figure 38.

The fact that elaborate models in both types are available often raises a question in the minds of prospective purchasers desiring the best, as to which form to choose. Both have their place, but in general the non-synchronic rotation type will be found easier and faster to work with and will do everything the synchronic rotation model will do, except under one condition, when the latter is unquestionably to be preferred. This is the study of crystals or other material at varying temperatures, requiring the use of a hot stage. When a hot stage is mounted on the regular stage, whether it be of the electrical or hot-water type, the connections to it make rotation of the stage a difficult matter. This condition is adequately met by the

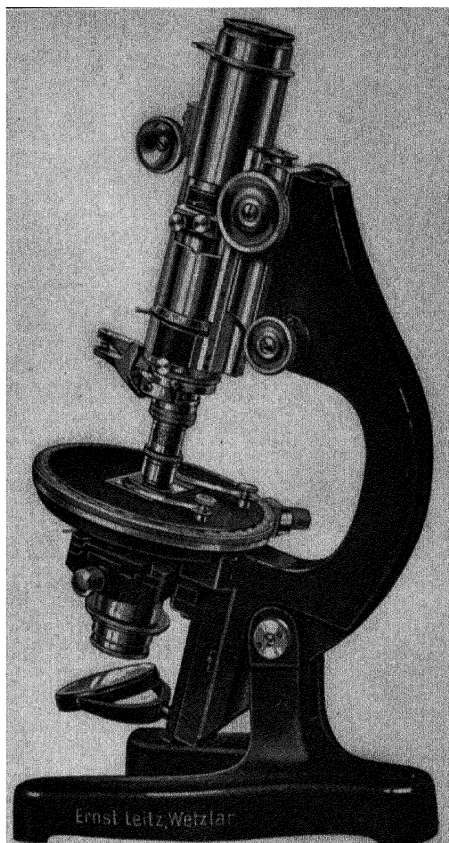

FIG. 37. Leitz Petrographic Microscope — CM

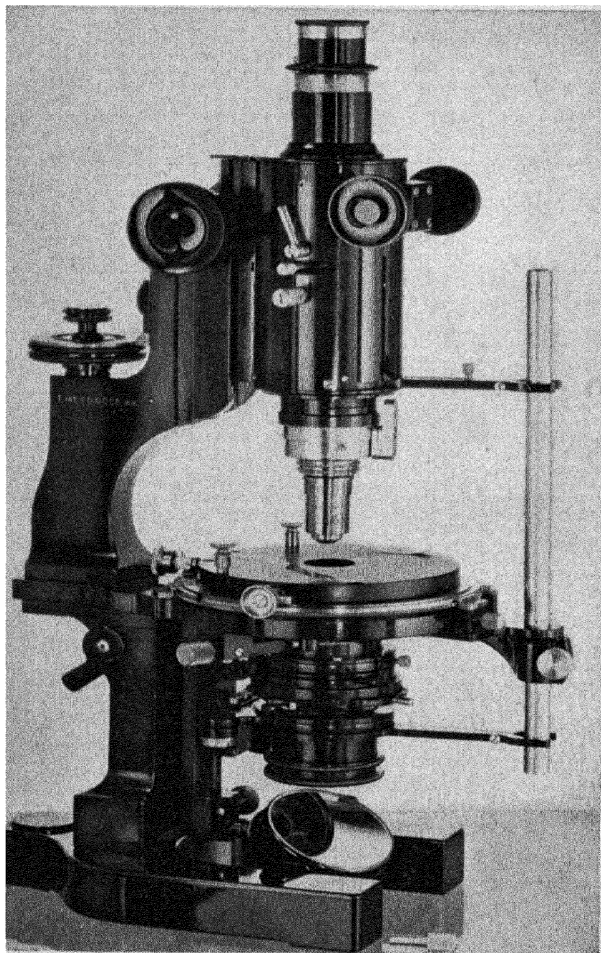

FIG. 38. Bausch and Lomb Petrographic Microscope
(Synchronic Rotation of Prisms)

alternative of synchronic rotation of the prisms. Therefore, if such work is contemplated it is preferable to choose a model which provides for it.

Metallurgical Microscopes

Another type of investigation also calls for features not found in general-purpose instruments. This is the study of metals, where polished and etched surfaces must be examined by reflected light. Illumination in this case is effected by means of a vertical illuminator located above the objective. The latter serves the double purpose of condenser and objective, the path of the rays being as shown diagrammatically in Figure 39. As the illuminator is approximately an inch high and as the thickness of the metal sample may be considerable, the distance between the stage and bottom of the tube must be greater than in biological instruments in order to accommodate these additional dimensions. This is accomplished by making the position of the stage adjustable.

But a still more important condition to be met is that the focusing cannot be done by vertical displacement of the tube, as the light source is usually projected into the side of the vertical illuminator from an extraneous source and the position of the latter must not be altered after the set-up is once made. Focusing (except for the fine adjustment) must therefore be accomplished by raising and lowering the stage. This condition is met in the more elaborate models by having the light source integral with the illuminator. When a research type of stand is provided with a raising and lowering stage, it can usually be employed for metallurgical work if equipped with a vertical illuminator.

Stands especially designed for metallurgical purposes, however, are not so elaborate, as there is no need of a substage condenser or mirror beneath the stage and no opening is necessary in the stage. The vertical illuminator is an integral part of the stand and an auxiliary foot is often provided so that the instrument can be removed from its base and placed directly on a large surface which may require examination. A microscope of this type is shown in Figure 40. The fact that so much present-day metallurgical work involves photographing of the specimens has induced manufacturers to design complete

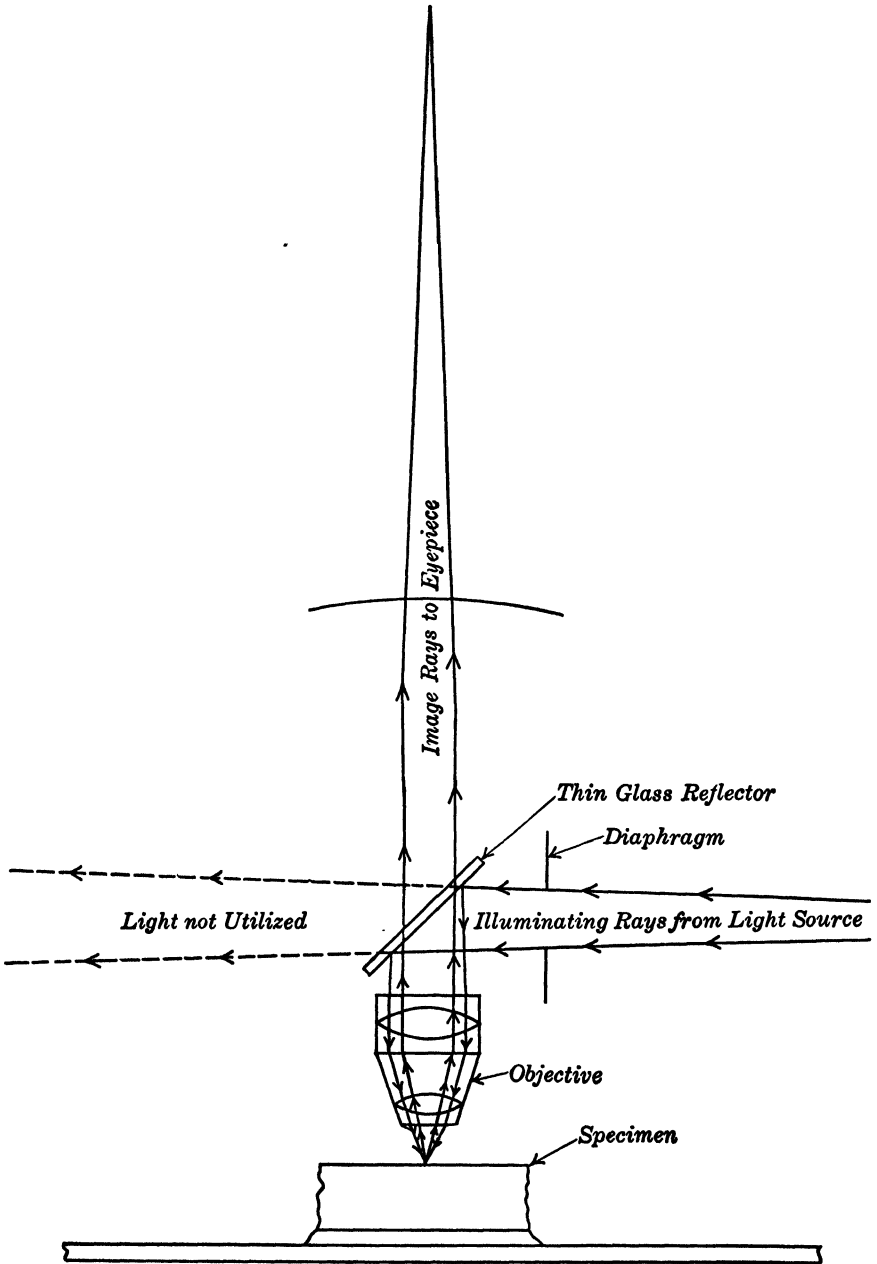

FIG. 39. Path of Light Rays in Vertical Illuminator

metallographic outfits which include the illumination source and camera as well as the microscope unit. In these, the latter is of the inverted type, with the stage on top. The polished and etched sur-

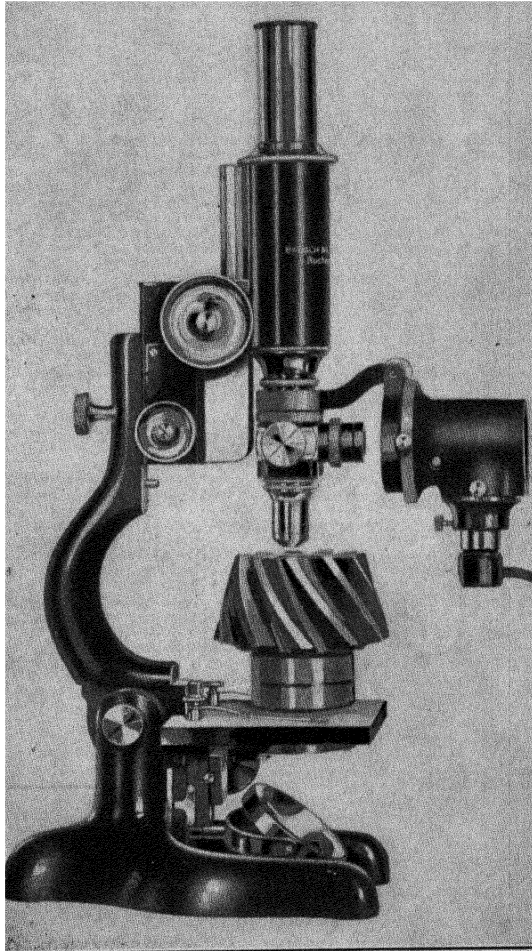

FIG. 40. Simple Metallurgical Microscope

(Courtesy of Bausch and Lomb Optical Co.)

face of the sample under examination is then placed directly on it, and viewed from beneath. The microscope partition of such an outfit is shown in Figure 41. For visual examination with this instru-

ment, a side tube is provided into which the image can be projected by means of a prism moved into the path of the rays for this purpose and out for photographing.

1. Specimen Holder
2. Stage Aperture Plate
3. Mechanical Stage Scale
4. Mechanical Stage Adjustment Heads
5. Objective
6. Objective Handle
7. Iris Diaphragm Adjusting Ring
8. Filter Mount
9. Vertical Illuminator Mirror Mount
10. Stellite Mirror Housing
11. Heat Shield Socket
12. Microscope Body
13. Observation Eyepiece
14. Camera Connector
15. Stage Casting
16. Coarse Adjustment Head
17. Fine Adjustment Head
18. Reducing Gear Level
19. Coarse Adjustment Scale
20. Coarse Adjustment Lock
21. Stabilizer

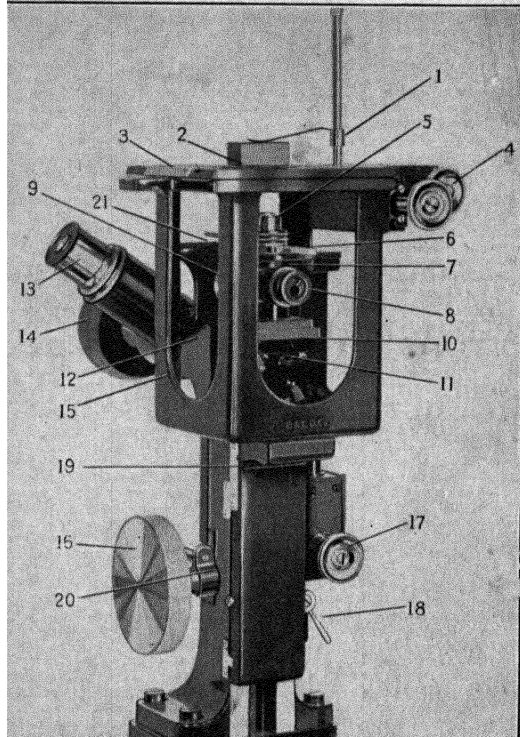

FIG. 41. Metallurgical Microscope — Inverted Type

(Courtesy of Bausch and Lomb Optical Co.)

Portable Microscopes

In addition to these lines of microscopes for general and specific purposes, other forms are available which should receive some notice. For instance, there are portable models designed for service away from the laboratory. Here lightness and compactness are the two essentials, hence the size of the stand is kept as small as possible and it is provided either with a folding base or other means of packing into a minimum of space.

Greenough Binocular Microscope

For low-power work where a stereoscopic image is desirable, the Greenough binocular is an important addition to the microscope family. In this type, each eye is provided with its own complete microscope, the paired objectives being mounted together at the approximate angle of binocular vision for a ten-inch object distance, i.e., about 15° . The rays from the objectives pass through Porro-

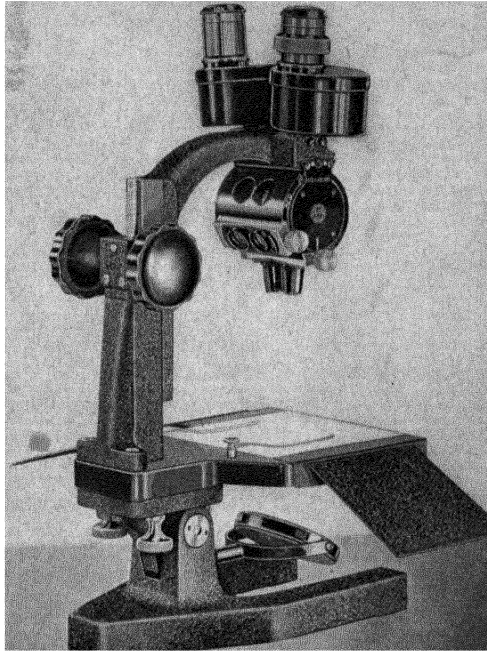

FIG. 42. Greenough Binocular Microscope

(Courtesy Bausch and Lomb Optical Co.)

erecting prisms similar to those employed with binocular field glasses, so that the image is not inverted. The prism bodies can be rotated so as to provide for varying interpupillary distances. These binoculars are ordinarily employed for opaque objects; the magnification range is from about $10\times$ to $300\times$, but above $150\times$, the magnifications are "empty" and not of much value. A typical Greenough microscope is shown in Figure 42.

Projecting Microscopes

For projecting microscopical images at a distance, various forms of projecting microscopes are available. As a matter of fact, any microscope can be used for projecting if it be rigidly aligned on an optical bench and the illumination train be highly efficient. But for less expensive outfits, simple stands are available which can be screwed directly on the lens mounting of a stereopticon. For low-power work these are quite satisfactory.

Brinell Microscope

Other simple, one-purpose microscopes, designed to do a specific job in the most efficient manner, are also available. A single instance

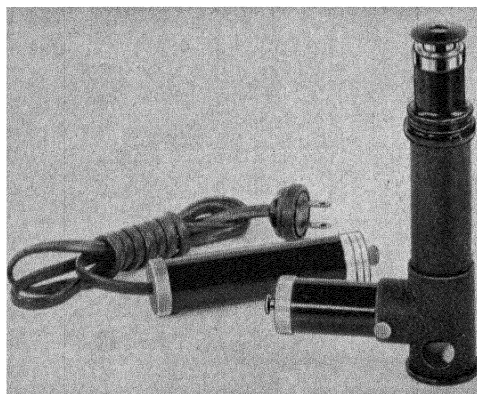

FIG. 43. Brinell Microscope
(Courtesy Bausch and Lomb Optical Co.)

of this sort is the Brinell microscope shown in Figure 43. In the Brinell hardness test for metals, a steel ball is pressed against a surface under a definite load; the resulting amount of indentation is an indication of the hardness of the sample under test, hence the diameter of the indentation must be accurately measured. The special microscope is provided with a micrometer scale in the eyepiece; by setting the instrument on the tested surface, directly over the indentation, the diameter of the latter can be read in terms of divisions in the scale.

Slit Ultra-Microscope

The slit ultra-microscope (otherwise known as the Siedentopf and Zsigmondy ultra-microscope) is another form for a very special purpose. This, however, is not merely a microscope, as the name might

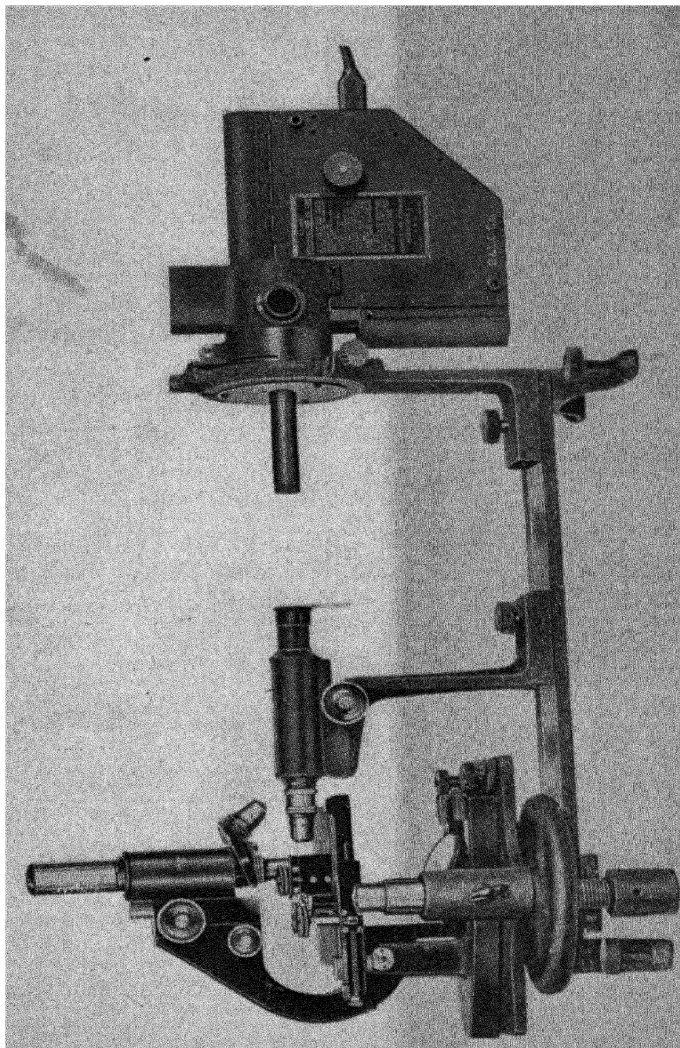

FIG. 44. Slit Ultra-microscope

(Courtesy Bausch and Lomb Optical Co.)

imply, but a complete unit comprising the illuminating apparatus (an arc lamp), with its optical bed, condensing system, the slit through which the size of the beam is controlled, and a special stand and optical system. The ultra-microscope is designed for studying colloidal solutions or transparent solids with colloidal dispersions in them. Its operation depends on the fact that minute particles of matter become visible when illuminated by a narrow beam of light passing transversely through them in an otherwise dark background. (This phenomenon is best known in the instance of dust particles in a darkened room showing plainly in a beam of sunlight.) In the slit ultra-microscope, the minute beam of light is passed through the

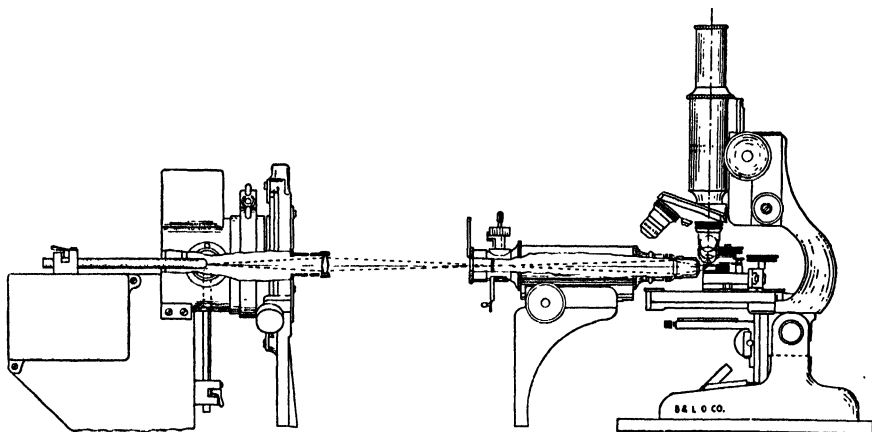

FIG. 44A. Cross-section Diagram of Slit Ultra-microscope Shown in Figure 44.

colloidal material under examination at an angle of 90° to the optic axis of the stand, hence no direct light reaches the eye and the field of view is perfectly dark. Any minute particles in the path of the rays are brilliantly illuminated and hence become visible under even relatively low magnification. The complete slit ultra-microscope outfit is shown in Figures 44 and 44A.

Where particle-size determination and counting are not involved or other requirements not so exacting, an approximation of ultra-microscope effects can be secured by means of various dark field condensers on ordinary microscopes.

Ultra-Violet Outfits

One other elaborate set of equipment sometimes passes under the name "Microscope," and so deserves recognition here, although it is more properly a photomicrographic outfit, for it can be employed as a microscope only indirectly. This is the so-called ultra-violet microscope. Here it is not so much the nature of the studied materials that is special, but the nature of the light used for the purpose. Resolution increases as the wave length of the light employed decreases; thus the maximum resolution can only be obtained by the use of short-wave, ultra-violet light, which is invisible to the eye. The wave length usually employed is the $.275\mu$ cadmium spark line produced by a high-voltage spark discharge across cadmium electrode. Even glass is opaque to this wave length, hence all parts of the optical system — condensers, objectives and eyepieces — must be made of quartz. The light from the sparking electrodes is passed through two quartz prisms which separate the light spectrographically to enable the $.275\mu$ wave length to be isolated from all other frequencies and projected into the microscope. Visual work, other than that of the coarsest sort (done with a fluorescent searcher eyepiece), is impossible and all results must therefore be secured by means of a photographic plate.

UNIVERSAL MICROSCOPES

The latest development to appear, in so far as radical microscope design is concerned, is the universal microscope. Several manufacturers have such apparatus available and already there is an appreciable demand for it from a restricted class of users. The equipment comprises, within a single unit, the light source and means for quickly converting it into transparent illumination or top illumination, as desired, with or without polarization; the microscope proper, and means for viewing the image either through an eyepiece or as projected on a screen; and finally, a camera for photographing the subject if desired. All change-overs are made in such a manner that ideal illumination conditions are maintained, and, intricate as the mecha-

*See also page 94, for description of a special objective by Bausch and Lomb for ultra-violet work, using the $.365\mu$ line of the mercury vapor lamp.

nism may be from mechanical and optical standpoints, its operation can be quickly mastered even by an inexperienced operator unaccustomed to the use of an ordinary research microscope. It is intended primarily for laboratories where a wide range of materials must be examined and where otherwise several different types of instruments

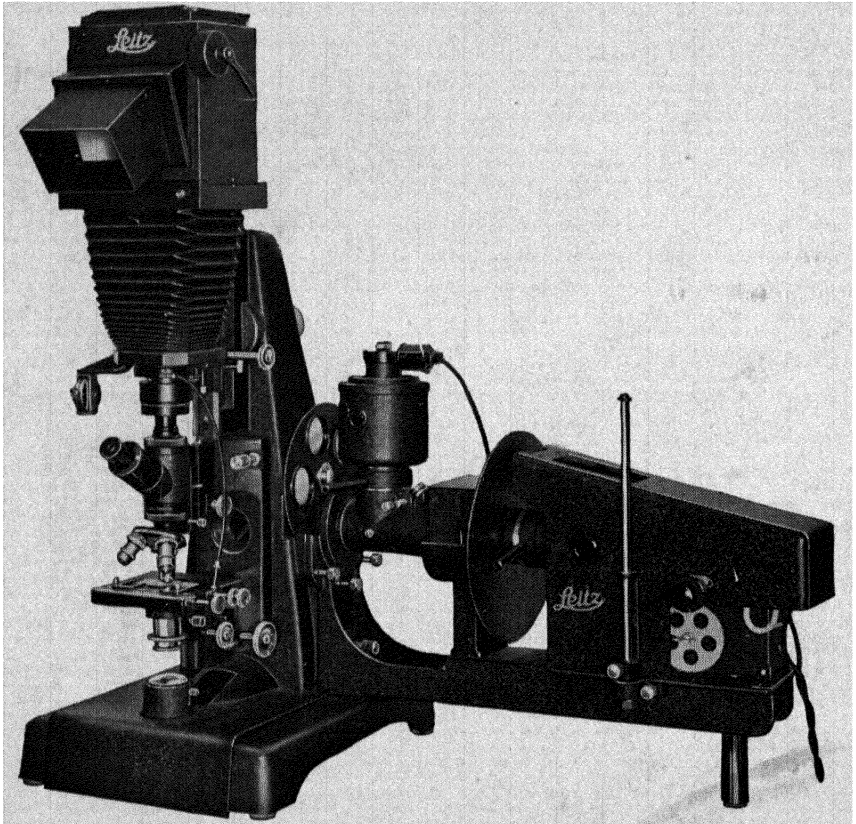

FIG. 15. Leitz "Panphot" Universal Metallographic Microscope

and considerable accessory equipment would be required; and also where the training of the operator might not be sufficiently broad to enable him to make his own adjustments for proper illumination under the various conditions. The equipment is somewhat bulky and, needless to add, rather expensive. The Leitz model of the universal microscope is shown in Figure 15 and the Zeiss in Figure 46.

ACCESSORIES

Not only have various types of objectives, eyepieces, and condensers been developed so as to extend the range of the microscope to the widest possible uses, but many other accessories are available for various purposes. Some of these are intended as supplemental equipment for less expensive models in order to extend their usefulness into the range of more elaborate outfits, or to adapt them in so far as practicable, for special lines of investigation which would otherwise require a complete special stand. Others are distinctly of an accessory nature, for any and all types of stands, designed to extend the range of work which can be done.

A superficial knowledge of what is available is often a material aid to anyone taking up new and unfamiliar investigations. To this end a brief outline of some of the principal developments in accessories is included here. Some pieces of accessory equipment require rather detailed explanations before the user will know how to get the greatest possible value from them. These will be discussed separately later.

Objectives

We have already mentioned some of the types of objectives and eyepieces in use, but a brief review of them when grouped as accessories is desirable, to provide some knowledge of the limitations of each type and of when the various types should be purchased with an outfit for a given service. Some of the questions that arise are: "Is the microscope required for use with transparent objects or with opaque

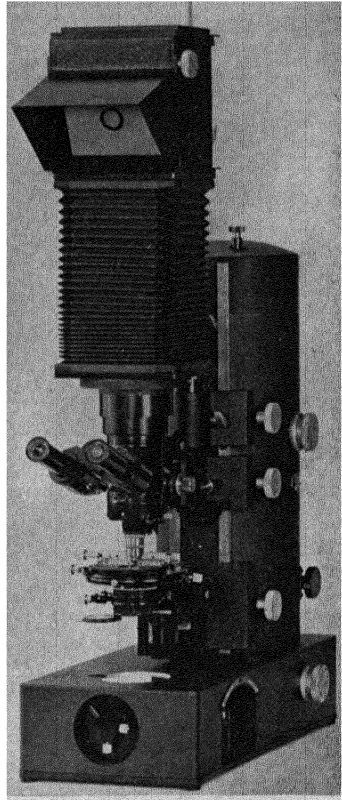

FIG. 16. Zeiss "Ultraphot" Universal Microscope Combined with Camera.

material?" "If the latter, is the surface flat or uneven so as to make stereoscopic vision desirable?" "Is the object to be covered with a cover glass or uncovered?" "How high a magnification is required, and how low?" These and many others like them have a bearing on the nature of the equipment necessary to do the work.

Achromatic objectives are available in all magnifications, from lowest to almost the maximum, and of a quality sufficiently high for all practical visual purposes. The medium and high powers are provided in two series, the regular, for use with covered objects, and the short mounts, for use with uncovered objects. The most common use for the latter is with metals and opaque objects, but they should be employed even with transparent objects when not covered.

Then in the more highly corrected lenses, the fluorites (often called semi-apochromatic) and apochromats, there is a corresponding double series for both covered and uncovered objects.

Where cost is no object, the apochromats will be found to perform better than achromats for visual work, but their greatest advantage over the latter is in critical photomicrography. It should be added, however, that for ordinary photographic purposes, good achromats will render very gratifying results.

In addition to the standard series in both groups, objectives for special purposes are available. Among these should be mentioned: high-power immersion apochromats with iris diaphragms for cutting down the aperture when using dark field; and special ultra-violet immersion (sandalwood oil) objectives (Bausch and Lomb) corrected so as to possess the same focus for the green line (.546) and the U.V. line (.365) of the mercury vapor arc, the former being used for visual focusing, the latter for photographing in the invisible range. Then there is the monobromonaphthaline immersion lens of 1.60 N.A. of Zeiss, for metallurgical work, and a complete set of quartz monochromats, corrected for the .275 μ cadmium spark line, also manufactured by Zeiss. The immersion lenses in this series employ dilute glycerine as the immersion fluid. To these we can add the water-immersion high-power lenses used with the quartz, window tube of the ultra-microscope; the very low-power water-immersion lens of Zeiss, known as the plankton searcher; special immersion lenses with large working distance, for use with quartz dark field chambers

and counting chambers where thick cover glasses are necessary; and the extremely low-power adjustable magnification lenses (the a* of Zeiss and Koriska). These latter possess a minimum magnification of about 1.5x with a working distance of at least three inches and include within their field of view an object of almost an inch in diameter.

Objective-Changing Devices

Quick-changing devices for switching from one objective to another are now considered essential on most stands, although they are not included as a basic part of the instrument. They are of two general

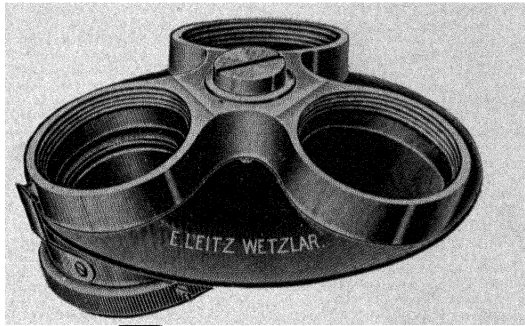

FIG. 47. Triple Nosepiece with Large Guard Disc (E. Leitz)

types, revolving and sliding. The former, ordinarily called a nose-piece, is furnished in double, triple, and quadruple form. Sliding changers require a separate slide collar for each objective, and a common slide holder fitted to the bottom of the tube. The revolving type is much quicker and safer to use, but the objectives cannot be individually centered as in the case of the sliding type. A triple nosepiece is shown in Figure 47 and the sliding changer in Figure 48.*

Eyepieces

In addition to the regular Huygenian series of oculars for achromats and compensating oculars for apochromats, many special forms of eyepieces are available as accessories. Most manufacturers supply a line of wide-angle and flat-field oculars possessing a higher degree

*Zeiss and Leitz furnish a special centering revolving nosepiece on petrographical stands.

of correction than the simple Huygenian type and priced considerably higher. These are designated by various trade names.

The fact that anything in the plane of the diaphragm in the eyepiece is in focus simultaneously with the microscopic image, so that the two appear superimposed upon each other, makes it possible to provide many modified oculars for special work. If a glass disc with an engraved scale be placed in the plane of the diaphragm, the combination becomes a micrometer eyepiece. Or the glass disc

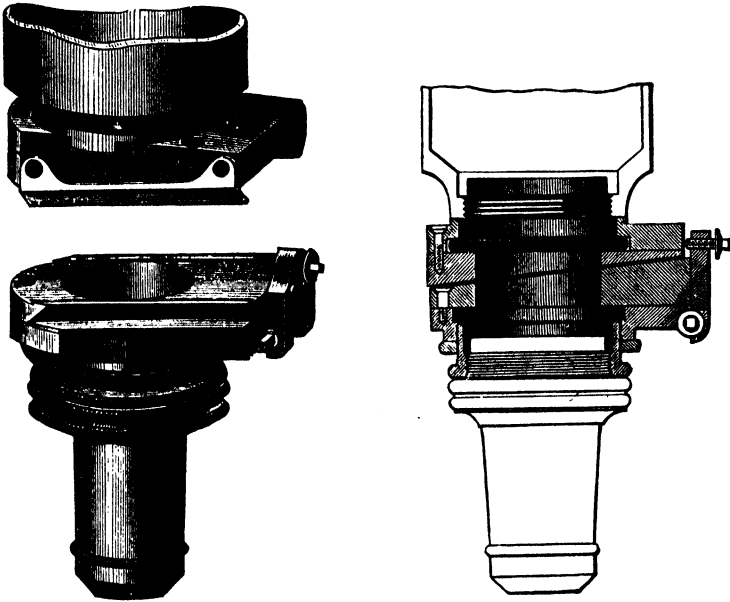

FIG. 48. Sliding Objective Changer (Carl Zeiss)

may take the form of a net ruling divided up into squares for counting purposes, or cross-hairs or other special indicating devices. Another such device is a mechanical pointer in the plane of the diaphragm, movable from the outside, by means of which a specific object in the field may be indicated to others. These are known as pointer eyepieces. In all eyepieces of this type, the eye lens is mounted in a sliding sleeve to make it adjustable with reference to the plane of the diaphragm. This is desirable for two reasons: first, to accommodate variation in individual eyes; and second, to bring the plane

of the diaphragm to the same focus as the image in photographing, where the focal position changes with every change in projection distance. With this micrometer type of eyepiece it is not necessary to employ a separate one for each purpose; the glass discs with the various engravings are commonly interchangeable, at least in the instruments of each manufacturer. Mechanically operated pointer eyepieces are, of course, not interchangeable with the glass disc form.

This same type of focusing eye-lens ocular is also made in very low powers for use as projecting eyepieces, an engraved circle being provided for setting to the proper distance.

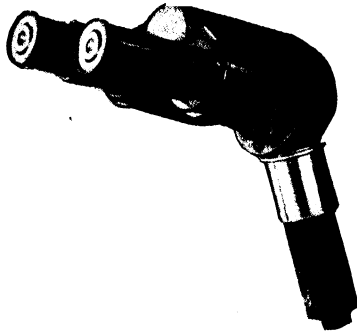

FIG. 49. Binocular Eyepiece

(Courtesy of Carl Zeiss)

Other special forms of oculars include erecting eyepieces (those having an optical system such that an erect instead of an inverted image is seen, and the movement observed corresponds in direction to that actually made); analyzing eyepieces, which are fitted with an Abbe analyzing prism, located between the field and eye lenses, for polarized light; dichroscopic eyepieces for observing pleochroism in petrographic sections of minerals; and filar micrometer eyepieces for very accurate measurements of minute objects. These latter differ from the simpler form of micrometer eyepiece in that the measurement is made by moving an indicating reference line through rotation of an external drum, graduated in hundredths of a millimeter.

Some manufacturers also provide a series of special eyepieces for photographic purposes only. The best known of these are the Homal oculars of Zeiss. They are of larger diameter than the standard 23 mm. and are not adapted for visual work. They are of consider-

able advantage in photography, as they yield a fairly flat field over the entire area.

Other accessories classed with eyepieces, but more elaborate in design, include such devices as binocular eyepiece attachments of the type shown in Figure 49. These can be fitted to almost any monocular tube instrument to convert it into the binocular type. They are of considerable advantage in relieving eyestrain when the microscope is used for long periods at a time; they can also be made to produce a three-dimensional or stereoscopic image. Then there is the demonstration eyepiece, whereby two persons can view the same object simultaneously. One form of this device is pictured in Figure 50.

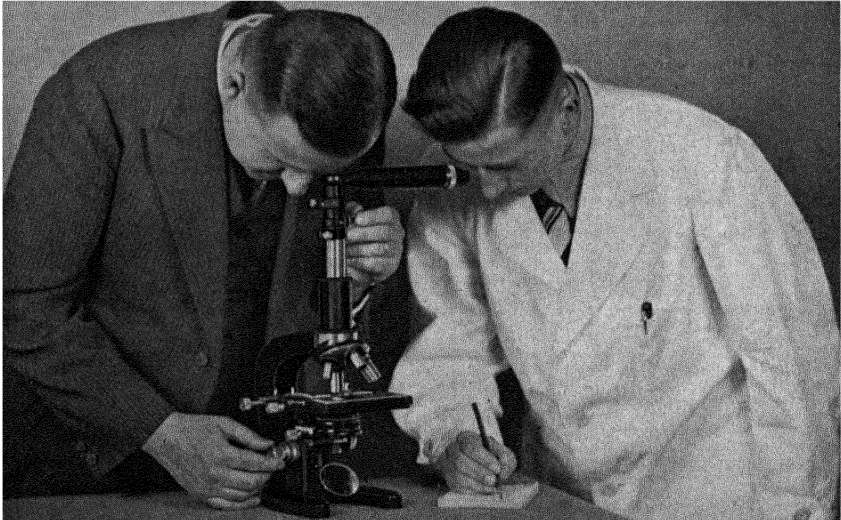

FIG. 50. Demonstration Eyepiece

(Courtesy of Carl Zeiss)

Still another eyepiece attachment is shown in Figure 51. This is known as a comparison eyepiece. It requires two microscopes with similar lens equipment, placed side by side at the proper distance for mounting over both. Then one-half of the field of view is that of one instrument and the opposite half is that of the other instrument. In this manner two different specimens can be compared side by side, and minute differences noted.

Sometimes it is necessary to maintain the stage of the microscope in a horizontal position, although comfort demands that the tube be inclined. For such work an inclined single eyepiece holder is available. This device is shown in Figure 52. Another simple attachment for use with a monocular tube is an eye shield which slips over the tube and covers the eye not being used, thus materially reducing eyestrain.

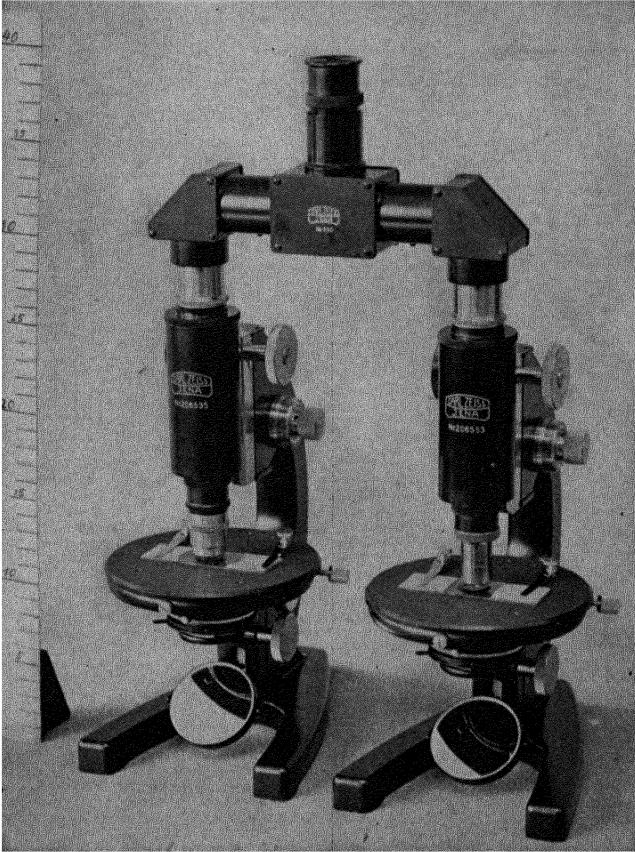

FIG. 51. Comparison Eyepiece

(Courtesy of Carl Zeiss)

Condensers

Accessories classed among the substage condensers start with the simplest form ordinarily supplied, the Abbe two-lens type with an

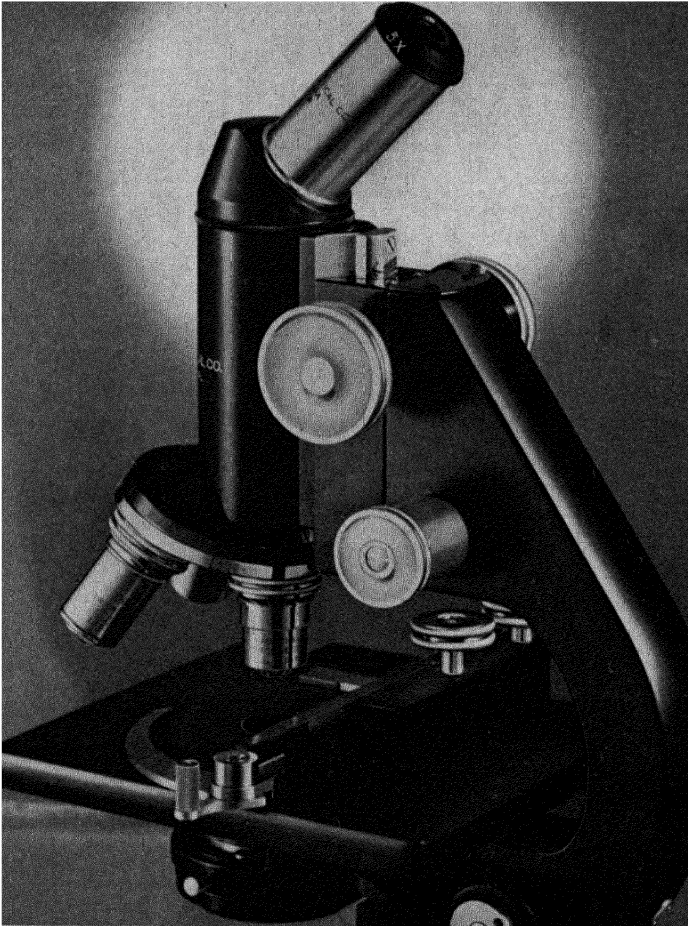

FIG. 52. Inclined Monocular Eyepiece
(Courtesy of Bausch and Lomb Optical Co.)

aperture (oiled) of 1.2 N.A. The three-lens Abbe type extends the aperture to 1.4 N.A. The aplanatic 1.4 N.A. condenser is a considerable advance over these, from an optical performance standpoint, in that spherical aberration is eliminated and all rays focus on the

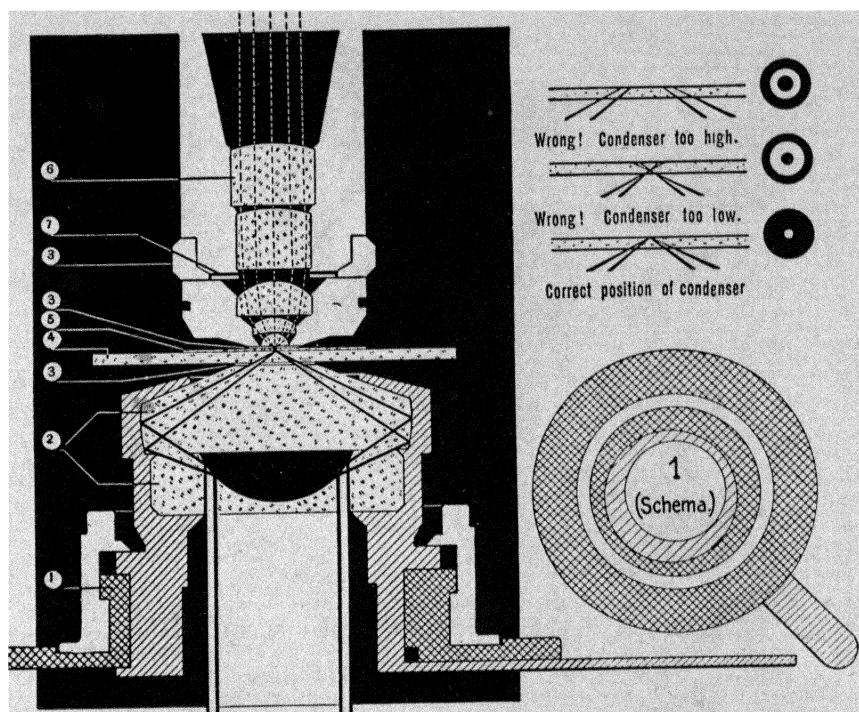

FIG. 53. Diagram of the Path of Light Rays in a Cardioid Type Dark Field

(Courtesy of Carl Zeiss)

plane of the object at full aperture. In the achromatic condensers both spherical and chromatic aberrations are eliminated; these therefore represent the highest possible degree of optical performance.

Some manufacturers provide centering condensers or centering means associated with the substage system. Zeiss also supplies a centering adapter which is threaded with the Royal Society objective thread and so can use ordinary objectives as condensers when desired. (This is such an important accessory that it is to be regretted that other manufacturers do not supply similar apparatus, as the Zeiss adapter does not fit many other makes of stands.) Such a device

also enables the use of condensers of English manufacture which are designed to fit the standard objective thread. For extremely low numerical apertures, three alternatives are available in addition to the use of a second objective of the same focal length in the center-

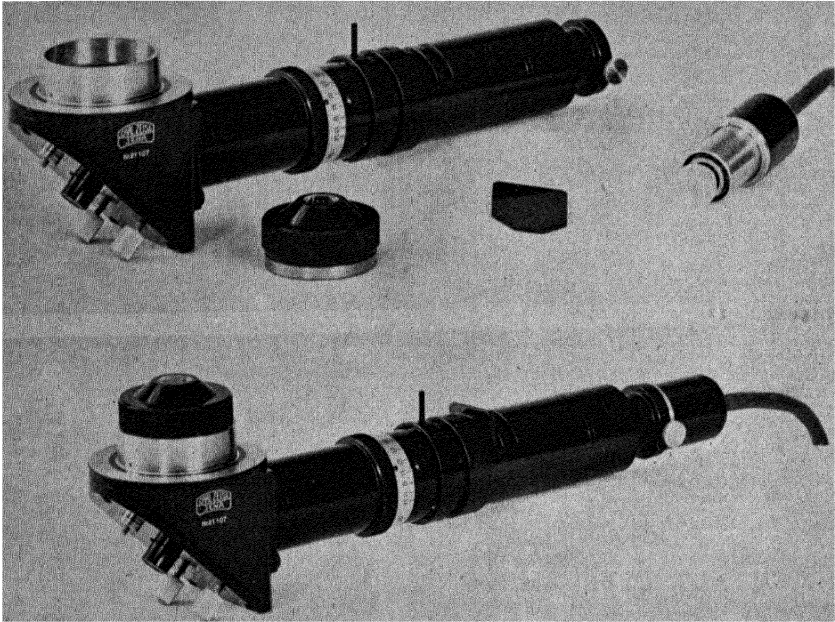

FIG. 54. ZEISS PANCRATIC CONDENSER

ing adapter. First is the separating form of condenser, where one or more of the top lenses are removable; second, the use of a supplemental lens below the ordinary condenser; and third, the use of low-power spectacle-lens condensers, provided in various focal lengths for this purpose.

In the special condenser class, the most important is the dark field type. This is made in many forms, by various manufacturers. The underlying principle is the same in all cases, that is, the blocking out of all direct rays within the aperture of the objectives employed. Usually this means that the limit is an N.A. of 1.0 for dark field, only rays of a higher aperture passing through the condenser, but some forms are on the market in which the limit is raised as high as 1.4

N.A. One method by means of which the dark field is accomplished is shown in Figure 53.

Combination light and dark field condensers are also available; the change-over is accomplished by throwing a small lever. The use

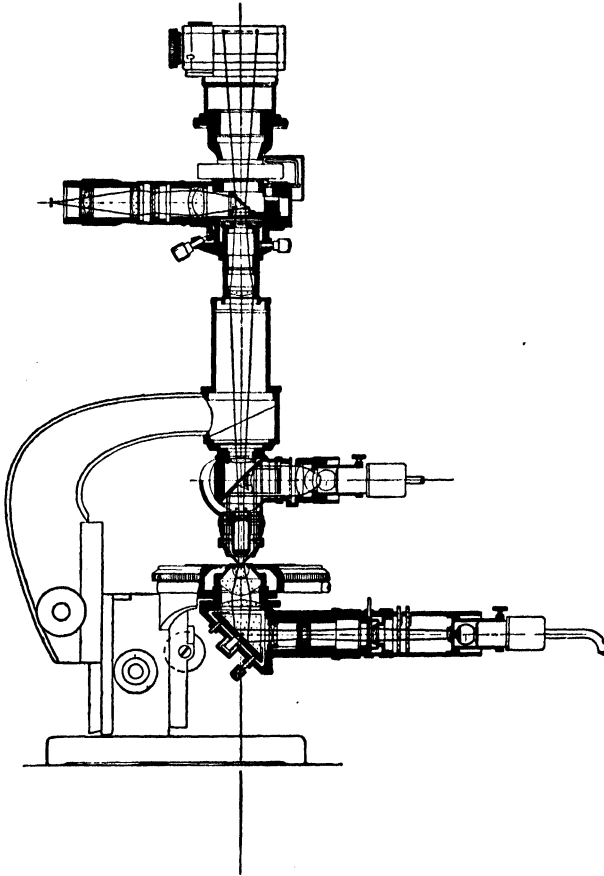

FIG. 55. Schematic of microscope equipped with Pancratic condenser for transmitted illumination; Epi-W condenser for top illumination, miniature camera and viewing eyepiece, giving an approximation of a universal microscope.

(Courtesy of Carl Zeiss)

of the dark field condenser and the particular advantages and limitations of the various types will be discussed later.

Another special condenser available for a limited type of service is the quartz condenser. Although designed particularly for use

with the ultra-violet microscope with quartz objectives, it finds considerable application in fluorescence microscopy by transmitted light. It mounts in the centering adapter.

Very recently a new piece of apparatus has been placed on the market by Zeiss, called the *pancratic condenser*. It is more than a condenser; it is rather a complete illuminating unit, consisting of the source of illumination, a small 8-volt lamp, condensers, aperture stop diaphragm, prism mirror, and 1.4 N.A. substage condenser — all mounting, however, in the substage sleeve. This represents probably the first attempt to combine all these functions in a single unit for transmitted light, although similar outfits have been in use for some time as vertical illuminator systems. The particular value of this apparatus is its simplicity of use, as it takes the guess and uncertainty out of the illumination problem for those not familiar with the underlying theories of critical illumination. This pancratic condenser is shown in Figure 54.

Apparatus for Illuminating and Viewing Opaque Objects

The trend toward ideal illumination units is further exemplified by the elaborate outfits of Leitz and Zeiss for illumination of opaque objects. Simple vertical illuminators, designed as accessories to standard microscopes, especially for the study of metals, have long been available. These fit in between the objective and the tube, and are of two types. The prism illuminators have a small prism mounted so as to cover one-half of the back lens of the objective. Light striking this prism through the opening in the side of the illuminator is reflected down through the objective to illuminate the surface under observation. The reflected light from the surface re-enters the objective and passes to the eyepiece through the portion of the back lens not obstructed by the illuminator prism. In the other form of vertical illuminator, known as the glass disc type, the prism is replaced by a thin disc of plain glass mounted directly in the optical axis at a 45° angle. Being unsilvered, it reflects only a portion of the light, the remainder passing out through a second opening in the opposite side of the illuminator. In the first reflection it is the reflected light that is utilized to illuminate the specimen, but as this light again passes to the glass reflector, it is

then the transmitted light that reaches the ocular, while the reflected light is returned toward the illuminating source and lost. The light efficiency of this type of illuminator is low. The prism reflector provides a more intense illumination but it is not strictly axial, it restricts the N.A. of the entire system, and it does not evenly cover the entire field. Because of these limitations the plain glass type is usually preferred unless the source of illumination is of relatively low intensity.

Both the prism and cover glass type illuminators are available, plain and combined with a condensing system and lamp; combination outfits are also made in which the prism and glass reflectors are quickly interchanged. It now seems likely, in the light of late developments in illuminators for opaque objects, that these older vertical illuminators will become obsolete for low- and medium-power visual service, although they will retain their value for high-power metallurgical work with the ordinary type of stands.

The Leitz "Ultropak" and the Zeiss "Epi-W condenser" outfits employ a system of illumination whereby the light, in the form of a conical ring, passes around the outside of the objective to be focused beneath it on the object. Special objectives are required, with special reflectors for each, all combined with a special condenser system and light source. By a set of interchangeable diaphragms, the Zeiss Epi-W can also be used as a vertical illuminator of the conventional type. It is probable that similar outfits by other manufacturers will be on the market before long, as this type of accessory forms a valuable adjunct to the microscope.

Polarizing Apparatus

It frequently happens that examination of some object by polarized light is desirable, although the stand available is not of the chemical or petrographic type. To meet this need auxiliary polarizers and analyzers are furnished by virtually all manufacturers. These are usually of the Nicol prism type, although the recent development of polarizing films of herapathite (quinine iodosulphate) has been responsible for a marked change in this respect; discs of the latter are a fair substitute for the more expensive prisms, for many classes of service. The polarizer mounts beneath the substage condenser; the

analyzer is of two types, either mounting directly above the objective or as a cap over the eyepiece. A set of polarizing prisms is shown in Figure 56.

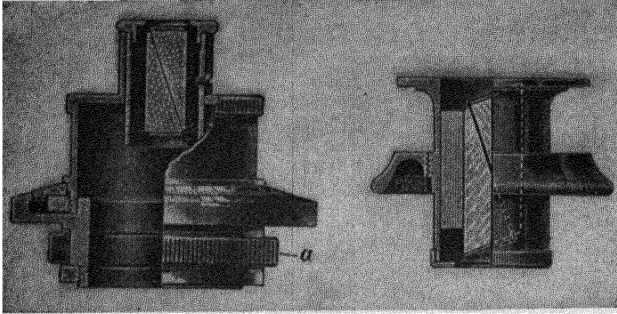

FIG. 56. Polarizer (right) and Cap Analyzer (left)

(Courtesy of Carl Zeiss)

Mechanical Stages

Though the more elaborate stands come fully equipped with mechanical stages, the simpler models do not, so that it becomes neces-

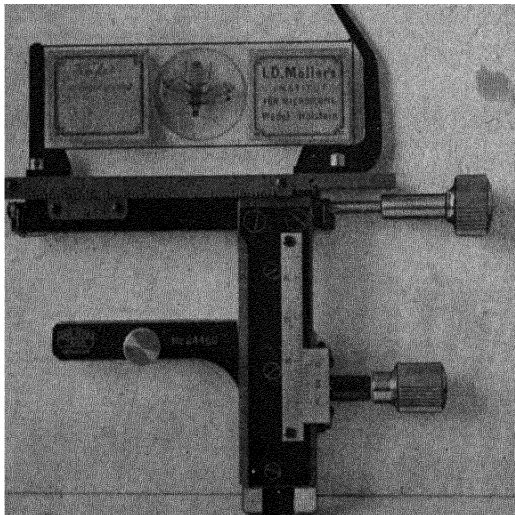

FIG. 57. Attachable Mechanical Stage

(Courtesy of Carl Zeiss)

sary to provide such stages as accessory equipment. These are available in many forms, to fit almost any type of instrument, one of which

is illustrated in Figure 57. Their primary value lies in the need for systematic exploration of every portion of a specimen, something which can be done in no other way. They also serve to bring a small object to the center of the field at high power, although with practice this can be done by hand manipulation.

Micro-Manipulator

Among the mechanical aids to specimen study, a far more pretentious piece of equipment is supplied by most manufacturers. This

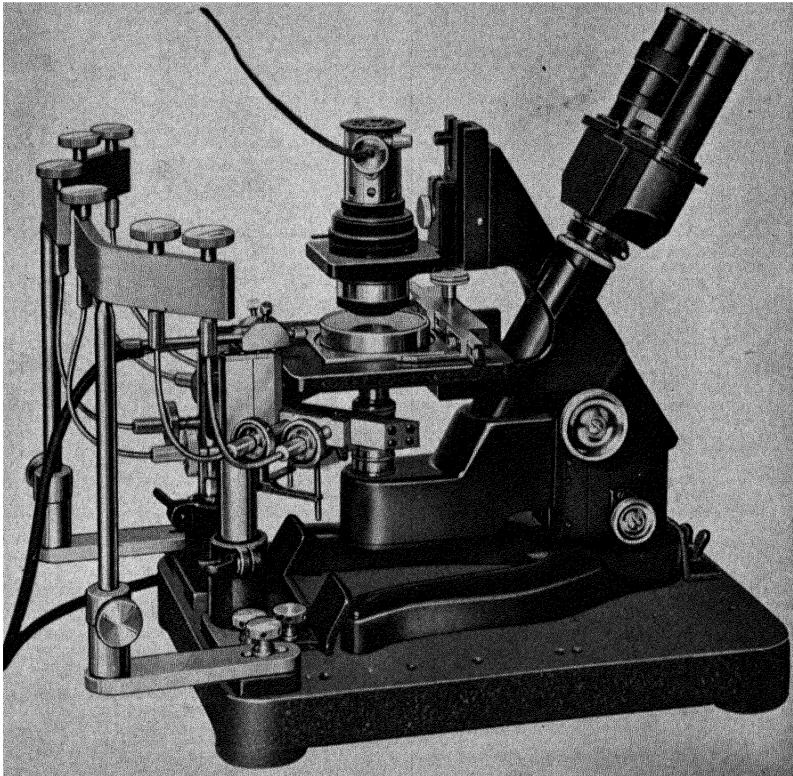

FIG. 58. Leitz Micro-manipulator with Special Microscope

is known as a *micro-manipulator*. While each manufacturer's design is based upon his own ideas as to what constitutes the ideal mechanism and consequently there is considerable divergence in the exact form

they take, they all possess general features in common. They must be heavy and massive, as the movements employed are usually of extremely minute dimensions and elasticity or looseness of mechanical parts cannot be tolerated. A heavy base is accordingly provided, on which the microscope is clamped, together with the pillars supporting the mechanical fingers which perform the various operations. These latter, equipped with minute tools of various kinds (largely made of glass) — needles, knives, capillary tubes, etc. — can be moved in all directions by means of micrometer screws. They are capable of performing marvelous feats in the hands of an experienced operator. A complete outfit, with the microscope in position, is shown in Figure 58.

Dissecting Microscopes

Going to the other extreme, in so far as elaborateness of equipment is concerned, but in work of the same basic nature, we find available an important piece of apparatus for many little services, particularly in the preparation of material for examination under higher powers. This is the dissecting microscope. This name might be considered somewhat of a misnomer, as the device is often only a stand for supporting a simple magnifying lens. Other more pretentious outfits are available, however, which have a stage upon which the work is done, illuminating means, arm rests, rack and pinion focusing of the lens, and (where the maximum of convenience and higher magnifications are desirable) a monocular prism erecting body employing a low-power objective and eyepiece. Of course, all the manipulating in this case is done by hand, using needles, scissors, scalpels, etc.

Although the foregoing section covers most of the accessory equipment intended to broaden the value of the microscope itself, or increase its flexibility, there are many additional pieces of apparatus that are requisite, or at least desirable, for one who would be thoroughly equipped for all classes of microscopical work. These, however, can be best discussed under other phases of the subject, where more consideration can be given to their particular uses.

Chapter 4

ILLUMINATION

Except for metallography and a few other lines of investigation, most microscopical studies are carried on by means of light passed through the object from beneath the stage, that is, with transmitted light. For this reason problems of illumination are largely those relating specifically to this class of work.

The source of the illumination can naturally be either daylight or artificial light. Occasional proponents advocate the former as preferable. This preference can usually be traced to a partiality for the whiteness of natural light as compared to the inherent yellowness of blue-deficient artificial sources. In times past light reflected from a white cloud in the northern sky was considered ideal. And so it is — but as to color only. Even if it possessed other advantages besides inherent whiteness to commend it, the disadvantages attendant on its use preclude its general adoption as a source of illumination. Among these might be cited the fleeting and transitory nature of even the best of clouds, their complete absence at times when most wanted, the impossibility of always locating the microscope near a window to utilize them, and most discouraging of all, the frequent use of the microscope in the hours after sunset. These factors result in forcing the adoption of artificial illumination as an almost universal substitute. As will be seen later, after a consideration of the theoretical side of the situation, this is no real hardship.

As artificial light can be obtained in so many different ways, both as to source and type of lamp employed, we cannot solve the problem by merely saying that artificial light should be adopted as the standard method of illumination. It will, however, facilitate arriving at some conclusions as to the ideal light for microscopical purposes, if we defer consideration of this phase of the subject until we have settled certain other problems relating to the practical formation of ideal images.

The important role that illumination plays in the formation of an ideal image is appreciated by relatively few of those who use microscopes. Many, perhaps most, tend to take for granted that the only requisite is sufficient light properly to illuminate the field; given an excess of light, they feel that it can be decreased by closing the substage diaphragm or lowering the condenser. On the other hand, to be certain that the quantity of light is ample, they tend to employ the concave rather than the flat mirror.

From one standpoint it is to be regretted that many manufacturers still furnish double-surface mirrors (plane and concave) as standard equipment. The concave mirror is, broadly speaking, a relic of the days when microscopes were frequently used without condensers, and the necessary convergent rays were provided by its use. It is, of course, of some advantage to have it available, provided that the plane mirror only is employed for general work and the concave side is reserved for the few occasions when its use is justified.

The fact that the concave mirror is available and of value under certain exceptional conditions warrants consideration of its application and limitations. Contrary to common belief, it has no value in high-power work, unless we except the single instance of inexpensive microscopes not equipped with substage condensers of any sort. Here it is better than nothing, as it does give converging rays of small angle. For low magnifications it has two fields of usefulness. The first of these is where low-power objectives (below 25 mm.) are employed and no provision has been made for removing the top lens of the Abbe condenser. Completely removing the condenser and substituting for it the concave mirror and a ground glass usually provides a superior illumination. Then again, critical light with a 16 mm. objective in combination with a high-apertured condenser cannot illuminate the entire field unless the light source is of large diameter (which is objectionable, as will be shown later). In this case, lowering the condenser will fill the field, although at a sacrifice of the critical illumination condition.

*An exception to this statement must be made to cover those cases where the manufacturer has designed the entire illuminating system (e.g., Leitz petrographical microscopes) so as to require the concave surface to be used for all ordinary purposes rather than the plane. In such instances the manufacturer usually issues instructions regarding its use, which should be rigidly followed.

For quick examination, however, where critical illumination is not essential, this deviation from standard practice is permissible, as a time saver; but frequently there is not sufficient light even when the diaphragm is opened. Rotation of the concave mirror into position usually corrects this trouble. The principal objection to doing this lies in the strong possibility that a return to the plane mirror will be overlooked in going back to higher powers. The recent practice of some manufacturers in providing a supplemental lens to slip into position under the regular condenser is much to be preferred to the use of the concave mirror.

With these few exceptions, it is better to forget the concave mirror entirely and employ only the plane mirror. The reasons for this will be apparent later.

Critical Illumination

We have mentioned critical illumination. Just what is meant by this expression and how does "critical" illumination differ from any ordinary sort of illumination? A thorough appreciation of what is involved in the answer to this question usually revolutionizes the microscopical work of those who have previously assumed that sufficient (yet not too much) light is all that is required. Both the underlying theory of critical illumination* and the practical means of securing it are easy of comprehension. Figure 59 (A) shows how the rays from a single point in the object plane enter the front lens of the objective, later to form the image of this same point in the eye. The entire image is the sum total of the rays from every point in the object proceeding in a similar manner into the objective.

The problem therefore divides into two: first, what is the ideal condition of illumination to give the best image of a single point in the field; second, how may this ideal condition of single-point illumination be extended to cover every point within the field of the objective? Let us assume that we desire to form an image of one point only;

*Naturally the theory of critical illumination is closely tied up with the theory of resolution, especially as set forth by Abbe. To introduce a discussion of this theory in the text, or even to intimate that a knowledge of it is essential to the securing of ideal images through the application of the practical aspects of critical illumination, is to defeat the very purpose of this chapter. It is, however, briefly discussed in the footnote on page 133, Chapter 5.

how shall we illuminate it? A moment's consideration suggests the logical answer — place a lens, identical with the objective, beneath the stage and focused upon the object, as shown in Figure 59 (B). This method of illuminating the object forms the theoretical basis of critical illumination, but certain other conditions enter into the problem.

In the first place, if conditions are to be identical on each side of the object, consideration must be given to the fact that the rays from a point entering the objective, upon leaving it converge at the conjugate focus to form an image of the point. This point lies within the eyepiece approximately the mechanical tube length distant from

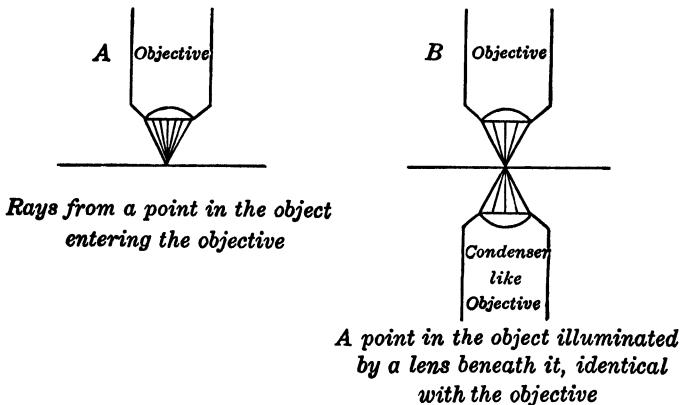

FIG. 59. Illustrating the Fundamental Principles of Critical Illumination with Transmitted Light

the front lens of the objective. Therefore if the conditions below the object are to be a replica of those above, the illumination must originate as a point of light located an equivalent distance from the front lens of the objective used as a condenser. Such a condition is obviously impracticable for several reasons, but fortunately an exact equivalent can be secured by two simple modifications. The first of these is to move the source of illumination farther away so that the rays are more nearly (or quite) parallel. The next step is to refocus the condensing lens, bringing it nearer to the object, until it once more produces an image of the light source on the object plane.

Bringing it nearer results in the angle of its cone of light becoming greater than that of the objective. At first thought it might appear that this would result in no harm, as the outer rays would pass outside of the objective and be lost, but this is not so, for, as will be evident later, we are in no actual case dealing with a single point in the object, but with an appreciable area. These rays of greater angular spread are picked up by the object and a foggy image results. In other words, the angle of the illuminating cone of light must in no case (dark field excepted) exceed that of the objective. Fortunately it is a simple matter to eliminate these excess-angle rays by means of a diaphragm of the proper size. When this condition is met, we have what is known as "critical" illumination, as related to a single point in the object plane.

The problem of critical illumination, however, is concerned with more than a single point; it extends to the entire field of view of a given objective. This implies that the diameter of the light source should be such that its image on the object plane is the same diameter as the area of the field embraced by the objective. If it were less, we should have the central portion of the object, as observed in the microscope, properly illuminated with an outer ring of the field dark.

So far we have assumed that in order to produce critical illumination the condensing lens is identical with the objective. This would work a hardship indeed, when any one of a large battery of lenses might be required, if a corresponding change were necessary below the stage. Obviously what is needed is some form of universal condenser lens which may be instantly adapted to any objective to provide an equivalent to it. This must of necessity be one that approximates the highest power and highest numerical aperture to be employed, as smaller cones of light to match lower powers can be obtained by using an iris diaphragm.

Experience has shown that for ordinary work, chromatic and spherical aberrations present in the condenser do not affect the quality of the final image to the same degree as they would in the objective; therefore less expensive constructions can be used. In the simple Abbe two- and three-lens condensers, practically no correction whatever is attempted. Of the two types of defects, spherical aberration is more detrimental to the perfection of the final image than chro-

matic aberration, hence the better grades of instruments are equipped with "aplanatic" condensers corrected for the former but not the latter. These are ideal for all but the most exacting work where expense of equipment is no factor. To meet this latter need, most manufacturers supply chromatically corrected condensers also, but at an increased cost.

Securing Critical Illumination

So much for the theoretical conditions producing critical illumination; the next step is the practical one of setting up the apparatus so as to be sure the lighting is critical for any given objective.

Starting with the source of light, we saw that the rays from it to the condenser must be substantially parallel. If not parallel they should

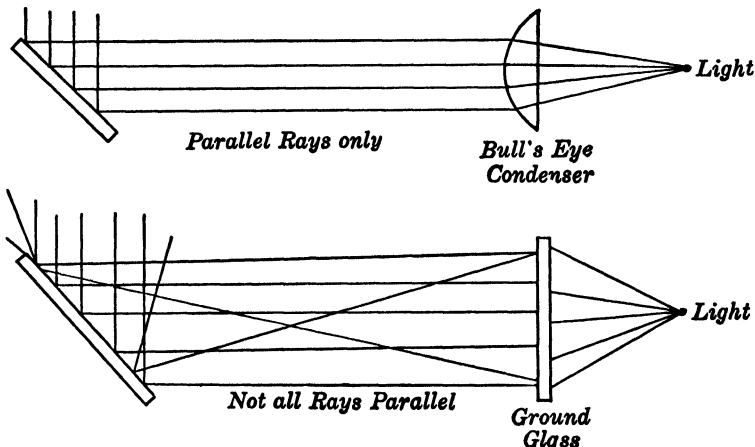

FIG. 60. Illumination by the use of a bull's-eye condenser located at its focal distance from the light source and by a ground glass interposed between the light and the microscope.

at least be symmetrically converging or diverging. For practical purposes there are two ways of accomplishing this: either employ a light source of very small diameter in combination with a condensing lens located at its principal focus, or a diffused light such as that produced by a ground glass, located far enough away so that all possible rays from the outermost zones to the substage condenser make only small angles. These two conditions are illustrated in Figure 60. The former is ideal, the latter an approximation of the effect desired only. It

will be evident that the actual source of light in the former, in so far as the illumination for the microscope is concerned, is not the light itself, but the condenser. Therefore it is immaterial how far away the light and condenser be placed; but with the diffused screen an increase in the distance improves the condition by decreasing the maximum angular divergence of the rays.

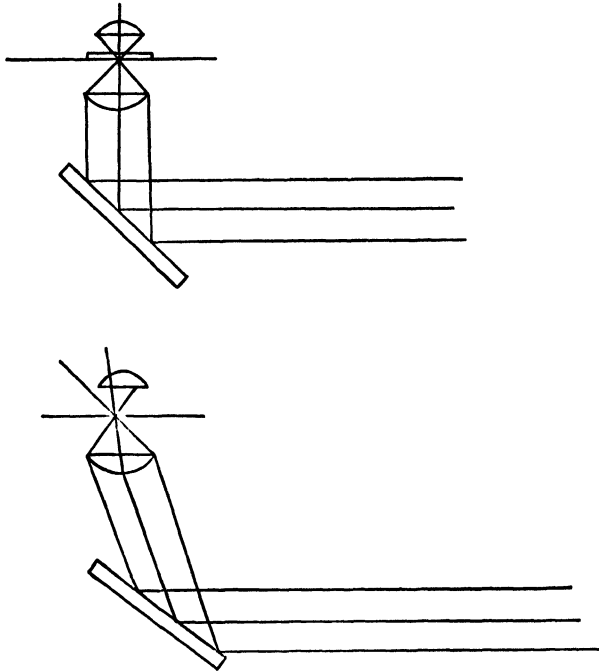

FIG. 61. Proper and Improper Method of Obtaining Axial Illumination with the Mirror

With the condenser method of producing parallel rays, it is imperative that the beam of light strike directly on the center of the mirror; with a diffused light source this requirement is not so vital. Figure 61 shows the reason for this.

Once the light question is settled, the next thing to consider is the mirror, the function of which is to direct the path of light into the optic axis of the instrument. This is accomplished by the plane mirror, which should be set so as to project the illumination into the

approximate center of the field. Assuming that a low-power objective has already been focused on a specimen on the stage, the next step is to adjust the position of the condenser until an image of the light source is seen sharply focused on the plane of the object. For instance, if the light source be an ordinary frosted electric bulb, an image of it, with possibly some of the surrounding fixture, can be seen. The top surface of the condenser under this condition, with an average thickness slide, should be almost level with the stage. If the object be mounted on a very thick slide, it may be necessary to rack the condenser as high as it will go. The light is now "critical" except for one thing; it must yet be adjusted to make the angular aperture equal to that of the objective. To do this, the eyepiece is removed; then, as one looks into the tube, the back lens of the objective can be seen illuminated. As the diaphragm of the condenser is opened and closed, its movement can be seen by the change in the diameter of the circle of light in the back lens of the objective. When the diameter of the light circle exactly coincides with that of the back lens, the angular aperture of the illuminating cone is the same as that of the objective, and the instrument is set for use with critical light. This procedure must be followed with each objective, but once the position of the diaphragm lever is ascertained for a given objective aperture, it can always be reset to the same place without recourse to a definite check each time.

After critical light is obtained in this manner, it frequently happens that the image of the luminant does not completely fill the field, particularly with low-power objectives. This is because the high magnification of the condenser necessary to match high-power oil-immersion objectives reduces the image of the light source until it is smaller than the field of view of the low-power lenses. If critical light is still to be maintained (it is not always so essential with low magnifications) the remedy is to increase the diameter of the light source or decrease the magnification of the condenser by removing one or more of the top lenses. When this latter is done, the focus of the condenser changes; it is then usually necessary to lower it until the image of the light is once more projected on the object plane. As previously suggested, for superficial examinations with low powers, where information as to relationships of various parts of the specimen is required

rather than detail in individual parts, it often suffices merely to lower the condenser (thus to some extent doing away with critical illumination) until the field of view is evenly illuminated. It is neither necessary nor desirable to do this with high powers, where critical illumination is most required.

The method of obtaining critical light just described was made possible by Abbe, through the development of his substage condenser, and is particularly applicable to the higher apertures, especially in visual work. Critical lighting can, however, be effected by an alternate method, suggested by Köhler. With low powers the Köhler is preferable over the Abbe method, especially in the illumination of large areas. In the principle, the Köhler method, when used for low-power work, is similar to that employed in the stereopticon for projection of lantern slides. The substage condenser, instead of being focused on the plane of the object, is focused more nearly in the plane of the optical center of the objective.* This is shown diagrammatically

*In high-power work, the image of the luminant is focused in the plane of the back lens of the objective.

From a theoretical standpoint it would appear that the Köhler method of illumination is superior to the critical illumination method described in that light from any point in the light source is uniformly spread over the entire area of the field of view, and hence no image of the luminant is superimposed on the plane of the object, and even with such nonuniform sources as filament lamps the field is uniformly illuminated. Not only is this true but the rays, in so far as the light source is concerned, are coherent, which is not so with the alternate method. Many of the elaborate outfits for photomicrography and critical microscopy have accordingly been designed to employ Köhler illumination. To do this, however, involves the introduction of factors and apparatus apart from the ordinary microscope equipment with its usual Abbe type condenser. In spite of a common opinion to the contrary, theoretical Köhler illumination cannot be achieved for high-power visual work with ordinary microscopes, standard 1.4 N.A. condensers, and a source of illumination. The reason for this lies in the extremely short focal length of the condensers and the fact that diverging rays must enter the condenser from substantially the lower focal plane, as they must leave the condenser only slightly converging. For ideal results Köhler illumination calls for a condenser designed specially to match each objective, although a set of three will effectively cover the ordinary microscope range.

It requires four more to accommodate the range of 20 mm. to 100 mm. objectives in photomicrographic work.

Because of these limitations it seems desirable not to go into detail here in connection with this method of illumination for visual purposes only. It is more important when dealing with photomicrography. For further information and complete diagrams of the path of the rays, the reader is referred to W. Zieler's article, "Illumination Systems for Photomicrography by Transmitted Light," reprinted from the *Journal of the Biological Photographic Association*, Vol. II, No. 1, September, 1933, obtainable from E. Leitz.

in Figure 62. Where it is desired to illuminate evenly areas of from one-quarter inch to an inch – as, for example, with magnifications of only a few diameters, projection, or photography – the advantage of

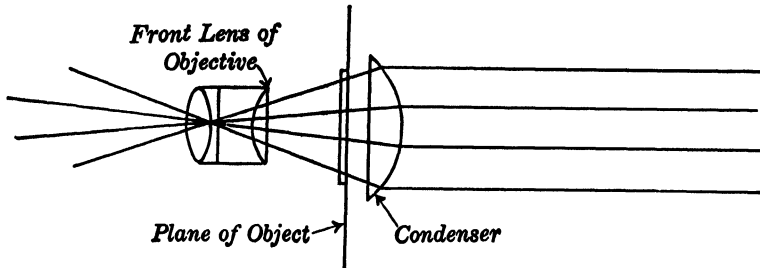

FIG. 62. Principle of the Köhler method of illumination. The exact focal point of the condenser varies with different magnifications. For low powers it is near the optical center of the lens (the plane of the diaphragm in planars and microtessars) while in high magnification it is near the back lens.

the Köhler method is obvious. For medium low-power visual work with the top lens of a high aperture condenser removed, either the Köhler or Abbe method can be employed with satisfactory results.

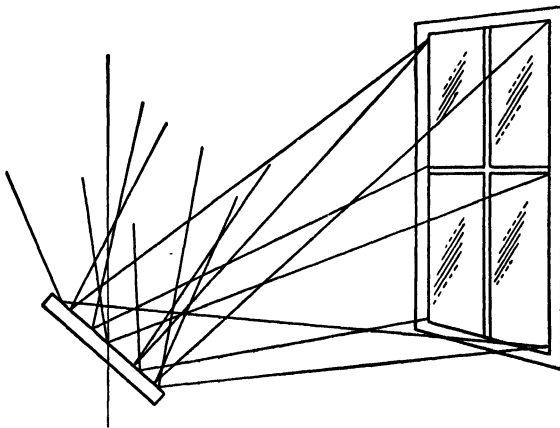

FIG. 63. Diffuse Lighting from Window. Illustrating the Unsatisfactory Nature of Daylight Illumination

With either method, the importance of parallel rays or a symmetrical cone of light entering the condenser, cannot be too strongly stressed, if the highest quality of image is to result. If light enters in

a haphazard manner at all conceivable angles, fogging is sure to take place. It is thus apparent why working with daylight and with the microscope close to the window give about the worst possible conditions. Figure 63 shows diagrammatically what takes place. Of course fogging is not so noticeable at low magnifications, but it increases rapidly as higher aperture lenses are used. If daylight is to be used, it is better to work several feet away from the window. Further, reducing the size of the illuminating area by means of a dark curtain will give improved results.

Now that we have shown artificial light to be preferable for microscopical purposes, the next question concerns the type of lamp best suited to the work. This is not so simple to answer, as varied conditions complicate the situation.

Fortunately the problems of the early microscopists, when electricity was not available and recourse to oil and gas lamps was the only solution, do not confront us today. Except for isolated cases, some form of electric illumination can be taken for granted.

All microscope manufacturers put out lamps of different designs, although the majority of these are far from ideal. Recent inquiry made to one of the large American firms brought forth the reason for this, the fact that lamps must be designed to work on either alternating or direct current. There are many direct current installations in this country; the existence of these materially complicates the lamp situation. Then again, some types of microscopical work (e.g., dark field) require an intense illumination. Manufacturers have tried to make a universal lamp to accommodate every need, but this cannot be done without sacrificing efficiency somewhere.

From the theoretical standpoint, it is apparent from Figure 8 that a point source of light, located at the principal focus of a short-focus condenser, is ideal. For practical purposes a diameter of one-quarter of an inch can be considered as a point; it would therefore seem easy to obtain such a condition. The fly in this ointment is the great intensity of almost all point sources of light available, and the fact that some of these require direct current for their operation; on the other hand, those that are nearest to the ideal can be run efficiently only on alternating current, in which case anyone having to work with direct current is out of luck.

For visual work with transmitted light, the intensity of the light must not be excessive. For photography, dark field, and indirect illumination, such sources as the carbon arc, "point-o-lite," tungsten arc, or ribbon filament lamps are eminently suited, but must be ruled out for ordinary visual purposes because of their intensity.

Where alternating current is available, a 6-volt concentrated filament automobile-type bulb of 8 to 15 candle power is an ideal light source. This can be operated from a small transformer giving the proper voltage on the secondary circuit, and there is vastly less heat loss than there would be if a rheostat were used instead of the transformer. This light source, placed at the principal focus of a short-focus lens of about $1\frac{1}{2}$ inches diameter and provided with an easily removable ground glass in front of the condenser, can be used for practically all visual, transmitted light, illumination. Most manufacturers are now putting out a lamp of this type. The larger lamps, of 50 to 100 watt capacity, operating directly on 110 volts, are not nearly so satisfactory for critical work.

Most workers find the white composition of daylight more restful than the yellow of artificial light for an apparent equal intensity of illumination. Also, in many instances it appears that more detail is resolved by white light. For this reason it is desirable to employ a daylight filter somewhere between the light source and the microscope when using artificial light. These, glass discs of a bluish tint for absorbing the excess yellow rays, create an approximation of white light. Most microscopes are provided with a slot under the condenser where filters can be slipped in; or filters can be mounted directly in the lamp housing. For this latter method, they are available either in clear or ground surfaces.

There is a prevalent idea that high-power work requires a more powerful light than one suited for medium and low powers, but this is not so. Although it is true that a given intensity of light per unit of illuminated area decreases for any particular objective inversely as the square of the increase in magnification, this condition actually obtains only as increased magnification is brought about through the use of stronger eyepieces. In securing higher magnification through a change in the objective, the light is automatically increased by the higher numerical aperture of the objective. This is accomplished in

two ways: first, through the opening of the condenser diaphragm to correspond to the higher N.A. of the objective, the light thereby being increased as the square of the N.A.; and second, through the increase in the light-gathering power of the higher-apertured objective, which also is as the square of the N.A.

On the other hand, the employment of binocular eyepieces allows the use of a stronger light source, as the total intensity must be divided between the two eyes, each of which is capable of utilizing as much as either alone.

The use of too intense an illumination should be avoided, for although the accommodation and fatigue of the eye will soon adjust to an apparent suitable intensity, it is at the expense of possible ultimate danger to the eye. If the eyes are not strained, however, there is no reason why any deleterious effects should result from long-continued use of the instrument. In many cases, it even seems that the eye most used for microscopical work becomes better than the inactive one.

Because of the important part played by the condenser in illumination, one other phase of the subject should be discussed here. For many years a spirited controversy has been carried on among microscopists as to the relative value of highly corrected condensers, centering, and micrometer-screw focusing. Clearly, three separate propositions are involved, and the relative importance of each is not necessarily the same. From the strictly theoretical standpoint it can be argued that the more highly corrected the condenser, the more perfect the ultimate performance of the instrument. This must be based on an assumption that the rays entering the condenser are equally well corrected, for no chain is stronger than its weakest link. Even with the employment of an aspheric condenser at the light source, there are still so many uncorrected factors present that the theoretical value of a highly corrected condenser over an aplanatic one can be completely wiped out.

That the condenser and objective should lie in the same axis for perfect performance goes without saying, but this does not necessarily mean that the condenser must be centering. What is required is that either the condenser or the objective should be provided with means for bringing them into axial alignment. It is entirely unnecessary

that both should be centering. With regard to a fine adjustment for focusing the condenser, as advocated by a few English microscopists, there is not much to be said in its favor and considerable in the way of objection. Extremely accurate focusing of the condenser implies a high order of correction in the condenser itself and in the entire illuminating train, for under any other conditions it is useless. From a practical standpoint it is an easy matter to bring even a high-power oil-immersion objective to an approximate focus by the use of the coarse adjustment alone. The same is true of the condenser, especially when it is focused by a rack and pinion. When the additional cost is considered, the odds are overwhelmingly against the use of a fine adjustment.

From still another angle we arrive at the same conclusion. In practical work we usually find that the theoretically perfect focus of the condenser is objectionable either because it gives an image of a ground glass diffusing screen at the light source, or worse still, of the lamp filament. To eliminate these, it is necessary to throw the condenser *slightly out of focus* — just sufficient to cause the field to become evenly illuminated. Preference is usually given to *raising* the condenser to accomplish this, rather than to lowering it, but it may sometimes happen that lowering it will yield better results.

Vertical Illumination

Problems of illumination with the vertical illuminator do not differ in underlying principle from those of transmitted light. They are simplified in one respect: the condenser is always the identical lens that is being employed as the objective. To obtain critical illumination it is therefore necessary to observe only two external conditions: the rays entering the vertical illuminator should converge at the same angle as the divergence of those leaving the objective* and the diaphragm should stop down the diameter of the cone of light just to fill the back lens of the objective. This is illustrated in Figure 39. Considerably more light is required for vertical illumination than for

*Or conversely, depending upon whether the Abbe or Köhler method is followed, the source from which the rays should diverge should be located the same distance from the illuminator mirror that the focal point of the objective lies above it, in the eyepiece.

transmitted light, because of the excessive losses involved. Only a small portion of the original light is reflected into the back lens of the objective by the thin glass reflector, and of the amount reflected back from the specimen, considerable is sent back toward the illumination source, hence the total efficiency is less than 25 per cent.

Oblique Illumination

Vertical illuminators are unsuited to most opaque objects; they find their chief usefulness in the study of etched metal surfaces. This is because there can be no contrasting shadows, because the viewing is done at exactly the same angle as that of the illuminating source. The image in this case is therefore one of contrast in the reflectivity of different components. For this reason illumination of opaque objects by means of oblique rays projected external to the objective is usually preferable. For low-power work, where there is considerable distance between the object and the objective, this is a simple matter; any method or lamp which will concentrate a bright light on the object is satisfactory. Even an overhead light with a short-focus "bull's-eye" condenser, such as that shown in Figure 64, works very well. Various illuminating devices for this class of service have been placed on the market — the Lieberkuhn, the concave side reflector, the Silverman illuminator, and others. Recent developments in illumination outfits, enabling the use of much higher powers, are the Leitz Ultropak and Zeiss Epi-W Condenser. These latter are very fine in their performance with opaque objects, but are rather expensive as they include not only the light source and condensing system, but separate objectives as well.

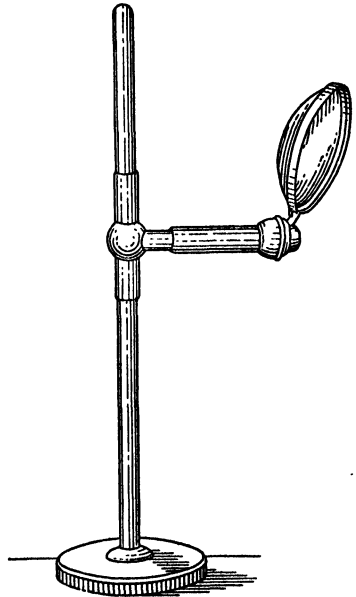

FIG. 64. Bull's-eye Condenser

Illumination for Dark Field

Illumination for dark field may best be provided by a carbon arc lamp, as extremely high intensity is required. Small 5-ampere arc lamps, both hand operated and automatic feed, are available. In lieu of an arc lamp, always choose the next brightest available. In all cases, the rays from the light source should be made parallel through the use of a condenser of ample diameter to cover completely and uniformly the back lens of the dark field condenser. The condenser itself should be in immersion contact with the bottom of the slide; the immersion fluid used should be that recommended by the manufacturer. In dark field work it is necessary to adhere strictly to the instructions for the use of a specific condenser as each different type may require variations in the set-up.

The advanced microscopist will be continually confronted with problems in which illumination plays an important part, but as these are more especially related to the individual conditions pertaining to specific cases, each must be solved as it arises. A general knowledge of fundamental principles usually suffices to point out the solution.

Chapter 5

TESTING OF MICROSCOPE OBJECTIVES

The objective is by far the most important part of the entire optical system of the microscope; upon it depends the quality of the image. When it is inferior, the most elaborate outfit will yield but mediocre results. It is also the part most complicated in optical design and the most difficult to produce to a uniform standard. And then, further it is at the same time the part most delicate and the most likely to be damaged part of a microscope. When something happens to an eyepiece or condenser, the derangement will usually be obvious even on casual inspection, but this is not so often true of objectives.

It is therefore evident that practical means for testing the performance of objectives are desirable. Experience has shown that there are certain standards to which objectives should conform in image formation. The extent to which objectives measure up to these standards can be determined by various tests. Tests which can be applied by the manufacturers during the making of the lenses are usually beyond the ability of the ordinary microscopist to duplicate. Those which are to be of value in service must be such as to be easily applied by the average microscopist.

In the early days of microscopy the need for comparative tests on objectives was far more important than now; not only did the products of various lens makers differ in performance, but differences could be observed between two lenses, ostensibly identical, turned out by the same manufacturer. Such conditions were responsible for the introduction of amateur tests to determine the relative quality of lenses of the same order of magnification.

The inherent defects responsible for the variations found included: over- and, under-correction of either spherical or chromatic aberrations, or both; presence of coma, due to nonfulfilment of the sine law; deficiency in aperture; poor resolution in the outer zone; poor center-

ing of the lens components; improper cover-glass correction; difference in visual and chemical focus; excessive polarization due to strains; and even distortion due to defective lens polishing.

Modern methods have changed all this. Greater technical knowledge in the computing of lens systems; more accurate machinery and testing equipment, working to closer limits; better and more uniform glass; the application of tests at every stage of manufacture; all operate together to produce objectives of the highest quality and uniformity. And this is equally true of all the better manufacturers, American, English, and European.

Because of these changed conditions, modern lenses are usually of a quality and uniformity which lie beyond which the average microscopist cannot discern differences with any testing means at his command. Rather than wasting hours trying to establish some slight degree of inferiority one is therefore almost forced to rely on the integrity of the maker and to assume that a new lens is satisfactory in every respect.

Yet this does not imply that there is no need for a knowledge of how lenses can be tested. On the contrary, such knowledge is of great value even in routine microscopical work, for it lays the basis for a subconscious detection of any abnormality which might at any time manifest itself in an otherwise perfect lens, and also enables one to ascertain the quality of lenses of older vintage which may come into his possession, or on which he may be asked to pass judgment. Moreover, the mere fact that lenses are now made of such quality that they no longer require careful checking to ascertain their performance, does not guarantee that they will remain perfect indefinitely. There is even the possibility (although this is rare) that a new lens will be delivered to a customer in a damaged condition. I have seen a high-priced immersion objective dropped by a clerk, during demonstration of an outfit, then carefully packed away for the next customer, without any check on its subsequent performance. Naturally, a purchaser breathes a sigh of relief when he knows he is not going to have that particular lens thrust upon him.

But it is mostly after a lens has been in service that something happens to mar its perfection. The nature of the flaws which can develop and the methods to employ for their detection should be compre-

hended by every microscopist. Many of these require only a visual examination with a hand magnifier or a Greenough binocular to make them evident, hence this simple test should usually precede others of an optical nature.

Probably the most common types of damage to occur in service — usually the result of carelessness — are scratching, chipping, or cracking of the front lens. If the defect is sufficiently serious to render the lens useless, the only remedy is to return it to the maker for repair; but if it is of only minor effect on the image, the extent of impairment can be determined by tests of the same nature as would be applied to the performance of new lenses. In the same category can be placed corrosion of the front lens, due to attack by chemicals, laboratory fumes, and, in rare cases, even by atmospheric deterioration. The degree of attack can range from the most imperceptible dullness, through iridescent colors (like an oil film on water), to positive roughness and clouding. Occasionally (and this is particularly true of apochromats of older vintage) interior clouding occurs. Another fault which develops, either spontaneously or when the lens is subjected to a considerable degree of heat, is an efflorescence in the balsam cementing two components together.

A very common accident occurring with high-power immersion lenses of great aperture, such as the 1.4 N.A. apochromats, is the loosening of the front lens, which is hyperhemispherical and so cannot be very securely mounted.

Rarely will a front lens be found which has leaked immersion oil through the lens seat into the back of the lens, but on the other hand, it is a very common occurrence for immersion oil or balsam from the slide to get onto the front lens of a dry objective, or for an immersion objective not to be properly cleaned.

With any of these conditions, injuries, or deteriorations present in a lens, its performance is sure to suffer. One is generally conscious of something wrong, as a haziness is evident which cannot be cleared up even by paying the most careful attention to critical lighting. In such a case, if thorough examination of the lens does not reveal any obvious cause for poor performance, one must ascertain whether it is the object and not the lens which is responsible. Especially is this the case with high-aperture, high-power, dry lenses, where a deviation

of only a few hundredths of a millimeter in the cover-glass thickness works havoc with the image.

The simplest way to eliminate this possible source of trouble is to provide oneself with a slide having a measured cover of the proper thickness. As it is essential that the specimen should also be thin and flat, it is best that it be a smear (blood or bacteria) or minute strewn objects such as diatoms or insect scales. If a stained histological section, it should be not over 5 to 7 microns thick and should adhere to the slide at all points. Waviness in a section may often be misconstrued as trouble in resolution of the objective.

After making sure that the subject under examination is suitable as a test object, the performance of the questionable lens should be compared with another known to be perfect and having substantially the same characteristics. In making the comparison, the highest power eyepiece available should be employed, as this will accentuate any deviation from ideal performance.

Abbe Apertometer

Equipment for the practical testing of objectives can be grouped into two general classes, mechanical devices and test objects. The former includes such apparatus as the Abbe apertometer and Abbe test plate. Figure 65 shows the apertometer.

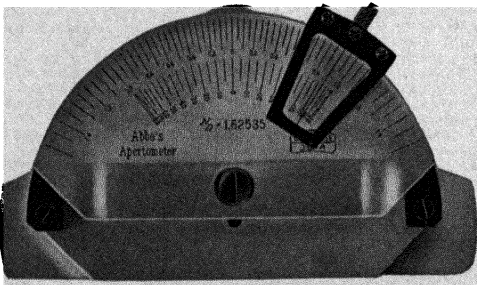

FIG. 65. Abbe Apertometer

(Courtesy of Carl Zeiss)

Its sole function is to measure the numerical aperture of a lens. The device, which consists of a thick glass plate in the form of a segment of a circle, is placed on the stage of the microscope with the objective over the center of the arc of curvature. Underneath the objective the plate is beveled so as to form a totally reflecting mirror. Light projected through the polished curved surface is reflected into the objective providing it enters the glass segment within the angle which corresponds to the N.A. of the objective; beyond this angle it does not enter. Therefore,

by the use of a supplemental objective screwed into the draw tube of the microscope and focused upon the back lens of the objective under test, the exact position where the marginal rays start to enter can be determined by means of movable targets on the segment. The latter is engraved with the corresponding numerical aperture, which can therefore be read directly, at the position where the target just becomes visible.

Measuring Aperture with Substage Condenser

As Abbe apertometers are quite expensive, and have such a limited field of application, it is often desirable to have available some other means of determining the approximate N.A. of objectives. Several such have been suggested, but none is simpler than the employment of the condenser diaphragm for the purpose. All that is required is to calibrate standard N.A.'s by means of objectives of known aperture and mark these on the position of the iris diaphragm lever, using the method described for securing critical light, to ascertain the position corresponding to a given N.A. Having done this for all available positions, measure carefully the diaphragm openings and plot the values so obtained on a graph against the N.A. values. This will give sufficient points on the curve to make possible plotting the entire curve with a fair degree of accuracy.

When an objective of unknown N.A. is to be measured the procedure is to focus the objective on a slide, obtain critical light, and bring the diameter of the condenser diaphragm into coincidence with the back lens of the objective; measure the actual diameter of the diaphragm opening and from the graph read the N.A. corresponding to this opening. The principal source of error in this method, if the work be carefully done, is introduced through variation in the thickness of the slide employed. This error is not present if the same slide be used for calibration and all future tests. The test is quite satisfactory for most purposes.

The Abbe Test Plate

The Abbe test plate is a much simpler piece of apparatus than the apertometer and at the same time has a far wider range of usefulness. Fundamentally it is a standard 3" × 1" glass slip, the object being a

silvered surface which has a series of straight lines engraved through the silver leaving alternate clear and opaque areas. It is available in two types with multiple covers (six) of varying thickness, ranging from .09 to .24 mm., properly designated on the slide, or with a single wedge-shaped cover extending over the same range. The latter is preferable, as it offers every possible cover thickness for testing, whereas the former necessarily has gaps between the various cover thicknesses.

Several different types of tests are possible with this simple test plate. It can be used to determine the optimum cover-glass thickness for which a given objective is corrected, and conversely, the extent to which the image suffers as the cover-glass thickness is varied away from the ideal. It can also be used to calibrate the amount of change in the tube length which will compensate for deviations in cover-glass thickness for any individual objective.

The nature of the object forms the basis for another complete series of tests. As it is an absolutely opaque object (i.e., the silver film) lying adjacent to a transparent area, the line of demarcation between them is perfectly sharp. There is thus present an ideal condition for observing the presence of color fringes or, in other words, the extent of chromatic aberration present. If an expert, one may ascertain the chromatic characteristics of a lens, the point of folding over (i.e., the preferred color), the degree of over- or under-color correction, the type of lens (achromatic, semi-apochromatic, or apochromatic), the perfection of the correction for spherical aberration, the presence of coma, and even the centering of the lens components.

Unfortunately for the amateur, a considerable degree of knowledge of the science of optics is necessary to perform the tests; but, on the other hand, with present-day perfection in the computation and manufacture of objectives, it is hardly necessary to waste time in trying to demonstrate the possible superiority of one lens over another by means of the test plate.

Diatoms as Test Objects

Amateur microscopists of the past generation relied upon mounts of certain species of diatoms and insect scales as test objects, *par excellence*, for determining the quality of their objectives. Diatoms are

unicellular algae which secrete silicious shells over their cell contents. There are many thousands of species, fresh water and marine, recent and fossil. Their value as test objects lies in the markings on the shell (known as the frustule). These markings are almost as diverse as the species, but generally take the apparent form of ridges or dots. Some are very coarse, so that they can be resolved by low-powered lenses, while others are so fine as almost to defy the resolving powers of the highest-apertured oil-immersion objectives, running at least 120,000 lines per inch.*

As already explained, the theoretical limit of resolving power is expressed by the formula

$$R = \frac{\lambda}{2 N.A.}$$

so that for white light, which has its optical center around wave length (λ) of $.550\mu$, we can compute the number of lines or dots per inch which a given objective should resolve if it is as good as it should be. From the large number of species of diatoms available, it is then an easy task to select some which have markings approximating the resolvable limit of the objective and employ these as test objects for determining if the lens be up to standard.

Although this sounds simple, there are certain factors present which complicate the situation and, in the majority of cases, render the test far more severe than can be justified by the formula alone.

The formula assumes an ideal condition of opaque sharp lines lying exactly on the plane of focus with a clear background, a condition which cannot be perfectly attained even with ruled gratings. But with the diatoms we are dealing with amorphous silica having a refractive index but slightly under that demanded as a minimum (i.e., 1.515) for the mounting medium if oil-immersion objectives are to be tested. The consequence is that instead of giving the needed contrast the diatoms, when mounted in such a medium as Canada balsam (index about 1.53), are practically invisible. Only by using a narrowed cone of light (i.e., reducing the effective N.A. of the entire

*The author has photographed a specimen of *Nitzschia singalensis* which runs 123,000 lines per inch.

system) so as to accentuate the slight difference between the refractive indices of the mounting medium and the diatom, can any appreciable contrast be secured. This condition may be partly met in two ways — by using some mounting medium with a much higher refractive index for diatoms intended for study under oil immersion, and by mounting dry (refractive index of air = 1) for objectives having an N.A. less than 1.00. This latter method gives a refractive index differential of almost .50, while realgar, with an index of over 2.0, gives about the same differential for immersion purposes. Mounting in realgar, however, is a very laborious and dangerous operation, and hence slides so mounted are both difficult and costly to obtain. Other mounting media with somewhat lower indices (around 1.80) are now available and fairly satisfactory but they do not equal realgar.

Another serious defect in diatoms as test objects lies in the nature of the markings themselves. They are merely structure patterns on or within the frustule wall and are not differentiated from it as to material, color, or degree of translucence. In other words, they might be likened, by way of analogy, to cheap cast glass imitations of cut glass dishes, such as are often sold in the five and ten cent stores. If we speak of a certain diatom as having 50,000 lines or dots to the inch, we must not conceive of these as sharp ruled lines but merely as ridges, protuberances, depressions, or other structural variations. They therefore become visible only through a refraction of the light and thus yield various appearances (e.g., the so-called white and black dot effect), depending upon the plane of focus.

Then again, almost invariably the diatom frustule is curved or rounded so that only a minute area will lie in the plane of focus; and to make matters still worse the frustule is in two parts (called valves), one of which, while one looks at the other, although out of focus and apparently invisible, still lies in the cone of light and to some extent interferes with it by forming indefinite defraction patterns.

To offset the reduced effective N.A. resulting from stopping down the condenser when studying diatoms mounted in such media as balsam or styrax, it is necessary to use oblique light, usually obtainable by decentering the condenser. If the decentering be sufficient to allow the cone of light to reach the outer margin of the back lens of

the objective, the number of interference maxima* responsible for the formation of the image and the resolution of the objective is not decreased, and hence the ultimate resolving power as expressed by the formula remains unchanged. What happens is that all the rays enter from one direction, giving what might be compared to a shadow effect, thus accentuating the contrast in the image. Figure 66 illustrates this in a simple manner. At *A* the outer circle represents the back lens of an objective, the circle just inside, the aperture of the condenser, which is almost identical. (If it were absolutely identical, there would be but one circle, for they would coincide.) If the eyepiece be removed and we look down into the tube, under this condition the entire area represented by the illumination circle appears

*It has seemed that a discussion of Abbe's diffraction theory of resolution through the formation of interference maxima is beyond the scope of the present work, although it is difficult to explain some effects produced, especially in the appearance of diatom markings under different conditions of illumination, without some use of the terminology employed in connection with the diffraction theory.

It would require much space to present the theory properly, but in non-technical terms it might be stated as the effect of diffraction on rays of coherent light (i.e., rays emanating from one source and consequently all in the same phase) causing them to spread out so as to travel paths of different lengths in passing to the objective. By analogy, it might be compared to a rank of soldiers, starting together, in step, on one side of a field and spreading out as they progress to the opposite side still keeping the same length of stride and time of step. When they reach the other side, the one traveling straight across would have covered the distance in the fewest number of steps; others might require one, two, three, or more (or some fraction in between) to reach the same line. Rays which are out of phase (i.e., step) one-half a wave length, or multiples thereof, cancel out or interfere with each other, producing darkness, whereas a maximum brilliance results whenever they are in phase, even though retardation equal to 1, 2, 3, or many wave lengths has taken place. Thus we can visualize the interference maxima (alternately light and dark) as repeated circles about the optic axis. Abbe's theory is that the resolution increases with the number of these interference maxima which can be picked up by an objective.

The theory itself has been the battleground upon which numerous physicists have waged war, pro and con; numerous objections have been cited against it, not least of which is that it demands coherent light for the production of interference maxima; and coherent light, as regards the light source, decidedly does not exist in the case of critical illumination where an image of the luminant is formed in the plane of the object. This argument vanishes, of course, if the assumptions of the Airy and von Humboldt theories are admitted as possible — that the object itself becomes the light source. Thus it would seem that a modification of the Abbe theory holds the true explanation of image formation: the resolution depends on the total number of interference maxima picked up by the objective, but the coherent light proceeds not, as predicated by Abbe, from the light source but from the object itself, made luminous by external exciting means.

filled with light. The dotted circles represent a certain number of interference maxima responsible for the resolution of the objective. At *B* we see the effect of stopping down the condenser. The number

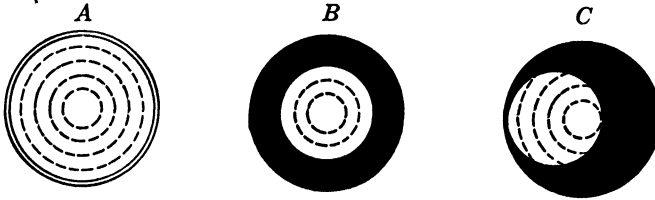

FIG. 66. Illustrating the principle involved in the use of a decentered, reduced cone of illumination, especially advantageous in the resolution of very fine diatom markings and similar objects.

of interference maxima formed have been reduced accordingly. The effective aperture in this case is

$$\frac{\text{N.A. of objective} + \text{N.A. of condenser}}{2}$$

This reaches its lowest limit when there is no condenser (*O*) and the N.A. of the system equals $\frac{\text{N.A. of objective}}{2}$. Putting this into the resolution formula and simplifying, we have

$$R = \frac{\lambda}{\text{N.A.}}$$

or just half that of that which is possible when a full-apertured condenser is used.

At *C* is shown the effect when the reduced cone of light is decentered until the two circles are tangent. The same number of interference maxima are formed on one side although the opposite side of the objective is functioning as one with but half the value of *R*. Laterally to the direction in which the illumination cone has been decentered, there is no increase in the resolution.

What bearing will this have on the resolution of the diatom markings? The problem is simplified if we conceive of a specimen with the marking in the form of dots, uniformly spaced in straight lines at right angles to each other. Such marking is well represented by *Pleurosigma angulatum* (and others of the *Pleurosigma* genus), as illus-

trated in Plate I. Let us further assume that the spacing of the dots is just within the theoretical resolving power of the objective under test.

If perfectly resolved, the appearance should be as in Figure 67 (A), corresponding to Plate I. With the decentered cone parallel to one row of lines, the dots are resolved in one direction but not in the other. They therefore appear as lines, as in Figure 67 (B). When the azimuth of decentering is rotated 90° the dots are resolved in the other plane, as at C.

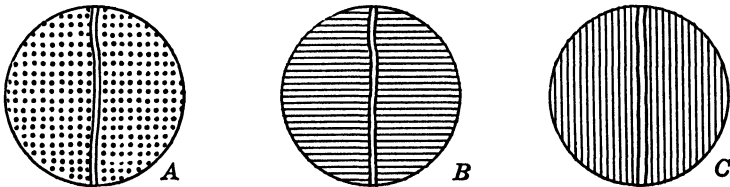

FIG. 67. Appearance of the markings of *Pleurosigma angulatum* with axial (A) and decentered illumination from two azimuths at 90° to each other. B results from oblique rays from the top or bottom; C is produced by rays coming from either side.

This will serve to show why diatoms are not ideal as test objects. Nevertheless they are invaluable for one particular purpose, the training of the microscopist himself. The manipulation of the light, the visualizing of differences in appearance which an identical object will yield under slight changes in illumination, the interpretation of the image in the light of the actual structure of the object, the relation of the refractive index differential to the formation of the image, and many other conditions which confront the practical microscopist, can be better illustrated by diatoms as test objects than with any other known material. When one is sufficiently conversant with the resolution of diatoms so that no known species will “stump” him, he is usually capable of properly interpreting the microscopic appearance of any material which may be placed in his hands for study. On the other hand, many present-day microscopists who consider themselves capable of properly handling the microscope in the solution of any problem involving its use, would find themselves all at sea if asked to demonstrate the markings on *Amphipleura pellucida* or even *Navicula rhomboides*, especially when mounted in balsam or styrax.

For this reason, it is desirable for every microscopist to have available a number of slides, especially of the more finely marked species, for high-power study. The diatom test slide by Moller is a very convenient (but expensive!) form in which to have them. It has nineteen species mounted in a line, in the order of increasing difficulty of resolution.

The following are suggested as ideal for study purposes:

- 1 – *Triceratium favus*
- 2 – *Navicula lyra*
- 3 – *Pleurosigma angulatum*
- 4 – *Surirella gemma*
- 5 – *Navicula rhomboides*
- 6 – *Amphipecta pellucida*

Insect scales, which include those of various butterflies and moths, *Podura* and *Lepisma*, at one time were considered valuable as test objects, but are now more or less *passé*. They are in no way as satisfactory as diatoms.

Ruled Gratings

Ruled gratings have also had their day. These are ruled by means of a diamond in a dividing engine, with groups or bands of about 10 lines spaced at varying distances apart, the coarsest being possibly 10,000 to the inch and the finest about 120,000 to the inch. Such test objects would be ideal if the line could be filled in so as to be opaque. With these, as well as with diatoms, there can be no air layer present between the top lens of the condenser (which must be oiled to the slide) and the front lens of the objective when testing immersion systems at their full aperture, hence the rulings cannot be mounted dry. Unless, therefore, the lines can be made opaque, they disappear in the mounting medium. So far, no really satisfactory filling material has been found; the best to date are colloidal graphite, carbon, or a dark dye.

Another drawback to the use of rulings is the difficulty of procuring them. They are expensive to make, require very fine machines to rule them, and are not required in sufficient quantities to tempt any of the optical manufacturers to produce them commercially.

Consequently the only ones available are the few that have been ruled by individuals in the past who were especially interested in such rulings. Most of these are quietly reposing in the private collections of such old-time microscopists as were fortunate enough to secure them.

Ideal Test Objects

The question naturally arises, in the light of the deficiencies in such objects as have been proposed and used as tests, "Is there not some other type of object which will be satisfactory for the average microscopist to use in determining the performance of objectives?" Before attempting an answer, let us first consider the requirements of such an object.

In the first place, it should be as nearly flat, or all in the same plane, as possible. Then it should be something with plenty of contrast in the portions used for testing. It should be mounted in a medium at least the equal of the glass slide and cover, i.e., balsam. It should possess both coarse and fine structure so as to be useful for a wide range of objectives. It should be best resolved with a full cone of axial light. It should work well with a green filter in case it is desired to check the ideal performance of achromatic and semi-apochromatic objectives.

There are several types of objects which meet these requirements more or less satisfactorily, but at the head of the list I would place a slide of human blood, well stained by the Giemsa method, preferably one with an abundance of white corpuscles, such as are present in a leucaemia. (It is only the white corpuscles which are of interest as test objects.) One need not be a haematologist to use the slide, for in this case it is not a question of interpretation of what is seen, but how clearly certain structures are revealed by one lens as compared with another. The diversity of structures present — granulation in the nuclei and cytoplasm, vacuolation, mitotic figures, and innumerable other features — offer an abundance of structure capable of taxing the capacity of any objective.

The ease with which the images produced by two lenses can be compared and slight differences (if any) between them instantly noted, makes this an ideal test object. One need not worry over

imaginary variations and their possible causes; the crispness and brilliance of the field, the sharpness of lines of demarcation, structures which are clearly revealed with one objective but appear less defined and hazy with another, tell the story. Because of the inherent curvature of the field, even with so-called flat field oculars, it is necessary, in order to make the test complete, to check the appearance at both the center and the margin, altering the focus with each lens sufficiently to accomplish this. It sometimes happens that with two lenses the images at the center will be identical but one will perform equally well at the margin of the field, as the focus is changed to bring this about, while the second lens will have a decidedly inferior image at the margin.

An alternate test object, practically the equal of a good blood slide, is a smear of the bacterial flora of the teeth, stained with carbolfuchsin. The great variation in the size of the various species of bacteria present in the normal mouth gives a wide range of test objects, so that the highest powers have plenty of material to work on.

Many other objects will suggest themselves. In the last analysis it will be found that almost any object which reveals increased structural details at higher powers will serve, provided that the person making the tests possesses the ability to interpret results.

It boils down largely to a question of making comparisons between lenses known to be good and others of unknown quality, unless one goes about it in a strictly technical manner, using the Abbe test plate. Even here one must have a mental picture of the performance of ideal lenses.

Inherent Polarization in Objectives

One other type of lens defect which can be serious for specific lines of research, although usually of no account whatever in ordinary microscopical work, is the presence of polarization due to strains induced in mounting the individual lens components. Unless the amount of polarization is excessive, the image does not suffer; but when polarized light is used, especially in determining birefringence of a low order, it plays havoc. For this reason petrographic microscopes are supplied with objectives guaranteed to be "polarization free." These are merely lenses picked from the regular run of manu-

facture and carefully examined for this particular feature. A little premium over the standard price is usually charged for these lenses.

As it frequently happens that one desires to use lenses supplied as standard equipment, for polarization work, it is useful to know how to examine them for the degree of polarization present. The test itself is very simple and can be made in a few seconds, but when polarization is obviously present, the question of determining whether it is serious is one that can be settled only by experience and comparison with other objectives.

With a polarizer in place beneath the condenser, an analyzer above the objective in the "crossed nicol" position, and a strong light projected into the microscope, polarization can be detected by removing the eyepiece and examining the appearance of the back lens of the objective. Low-power lenses should show uniformly dark and no change in their appearance should occur as they are rotated through a quarter to a half turn in the screw thread. If they are not dark, if they have a brilliant cross or irregular light areas which change their appearance as they are rotated, polarization is present, the degree of polarization being indicated by the relative brilliance and the extent of change which takes place.

With higher-aperatured objectives, because of the extreme angle rays which are picked up the back lens will always show a dark cross on a lighter field, the arms of the cross corresponding to the vibration directions of the prisms. If no polarization is present, the cross remains stationary as the objective is rotated. Any change taking place in the appearance of the back lens during rotation indicates the presence of polarization. The use of a selenite plate of the first order helps to make the test more sensitive.

If very *unusual* irregular figures are formed as a lens is rotated, the polarization present is probably so severe as to affect the image even when the lens is used for ordinary work. This often indicates some accident to the lens, probably its having been dropped.

CHAPTER 6

GETTING THE MOST OUT OF THE MICROSCOPE

Ownership of a microscope does not constitute one a microscopist; neither does being set to work with one in a commercial laboratory. The instrument is but a means to an end. The connecting link is experience; even cramming information from books is no substitute, although books are an ever-present help in time of need and a worthy supplement to experience.

The end itself might be defined as the ability to state accurately the micro-structure or nature of any material or object presented for examination on the basis of what the microscope reveals. Before this can be accomplished, a certain amount of training in the use of the instrument is essential. The first things that a novice should learn are how to take the proper care of the microscope and its various parts and then how to operate it proficiently.

I. The Care and Manipulation of the Instrument

The microscope, in both its mechanical and its optical parts, is a precision instrument designed for accurate work. If it is to continue to perform at its best, it must receive the best of care, not only during active service but in periods of inactivity. For protection when not in use, as well as for transportation, instruments are almost universally supplied in suitable wooden cases.

Unless a microscope is in use continually, or required at instant notice, it is better that it be put away in its proper case immediately after one is through with it. The alternative is to have a bell jar of ample size to fit over it. When this is used the objectives are allowed to remain in the nosepiece and an ocular should be left in the tube to exclude dust which might otherwise fall into the objective.

Whichever plan is followed, care must be exercised in handling the instrument. With the bell jar it is easy to mar the finish of the base or some other part if the jar be removed or replaced carelessly. This

is not so apt to occur when the instrument is placed in or removed from a wooden case. The chief possibility of accident when the instrument is unpacked and repacked lies in dropping a lens as it is being unscrewed from the nosepiece. The art of obviating this danger should be mastered at the outset. One rule should be enforced as rigidly as the laws of the Medes and Persians: *always use two hands*. Some people become adept in removing a lens with one hand, but sooner or later one is dropped and chance alone determines how much damage is done.

Putting an eyepiece into the tube or changing to a different power ocular does not involve so serious a possibility. Eyepieces should always slide easily into the top of the tube. Care should be exercised the first time one is used to be sure they do slide easily. If one should be found that fits tightly, it is better to exchange it for one that is satisfactory.

The instrument should be kept free from dust by means of a soft cloth or a camel's-hair brush. If it is used in a laboratory where excessive moisture, acid fumes, or other chemicals of a corrosive nature are present, all possible precautions should be taken to see that they do not deteriorate any part of the instrument. There is very little need of oiling any of the movable parts of a microscope. Occasionally the rack and pinion slide may gum up and work hard. If this happens, the gummy deposit should be removed with a little thin oil on a cloth and then the surfaces rubbed over with a minute amount of vaseline. Gumminess on eyepieces or within the tube should be removed as often as required. Should the coarse adjustment become too loose, it will usually be found that some provision has been made to tighten it.

The outer surfaces of the objective and eyepiece lenses should be cleaned carefully when necessary with a soft *clean* cloth or piece of lens paper. In case balsam or cedar oil accidentally gets on a surface, it can be cleaned with a cloth moistened with xylol. Under no circumstances should alcohol be used for this purpose, as it is likely to dissolve the cement often used for mounting the front lens.

Objectives should never be taken apart with the idea of cleaning inside surfaces; furthermore, they should never need it. On the other hand, eyepieces, especially older types, sometimes sweat on the inside

and precipitate over the inner lens surfaces a film which should be removed. If this is done, care must be taken to screw the lenses back exactly as they were originally, and not to cross-thread them.

The fingers should never be allowed to touch the surface of any of the lenses in a microscope, as they are sure to leave a greasy film which is difficult to remove.

After a microscope has been set up, the objectives have been screwed in place,* and the source of illumination has been placed in position, the next step is the placing of the object (usually in the form of a slide) on the stage. When a nosepiece is used (as is the most common practice) and the reserve objectives are mounted in it, care must be taken to not strike any of the objectives with the slide, as either the front lens or the finish may be damaged thereby. This, a common happening, can *always* be set down to carelessness.

Before attempting to use a series of objectives for the first time, there are several precautions which the novice should take. In the first place, if possible, the manufacturer's data on the objectives should be consulted to ascertain the working distance, i.e., the distance between the cover glass of the slide and the front lens when the latter is in focus.† This will serve as a guide as to the position where an image should be expected. Should this information be not available, it is always wise to lower an objective carefully until the front lens almost touches the cover, before looking into the eyepiece; then, while carefully watching in the eyepiece for the appearance of the image, slowly elevate the tube with the rack and pinion coarse adjustment.

Until one becomes somewhat proficient in handling the instrument, it is better to employ only the lowest-power objective. When this has been mastered, then proceed to each of the higher powers in turn.

After the image has been brought into view with a low power and carefully focused with the fine adjustment, critical lighting should be attempted, as outlined in Chapter 4.

*Some manufacturers indicate on the nosepiece where each objective is to be mounted. In such cases it is better to follow the marking rather than to screw them in indiscriminately, as they may be better centered in the designated positions.

†See table on page 59.

Something that the novice will notice when he uses a microscope for the first time is that the image is inverted. Obviously this is not serious in itself, for if it be desirable to see something right side up, it is necessary only to invert the object. It does, however, have one correlated result that is not so easily taken care of. All apparent movement of the object is in the opposite direction to the actual movement. There is no help for this, except moving the slide in the opposite direction to that in which one desires it to go. A little practice will enable anyone to become quite proficient in doing this, and also in deciding how much actual movement to impart to the slide to bring something from the margin of the field to the center.

Microscopes intended for high-power work usually are, or can be, fitted with mechanical stages having screw-controlled motion in two directions at right angles to each other. These are indispensable when an entire slide must be examined systematically so that every portion of the area is to be subjected to study; but when one becomes proficient in manipulating a slide with the fingers, the proper motions can be performed even when using the highest magnifications. Moreover, for a superficial examination at low power, the fingers will be found far more convenient than a mechanical stage.

When the user has attained confidence in the operation of the instrument through operation with a low power, he can then try out the higher powers. After the condenser has been properly focused for critical light, the only change required when objectives are changed is the opening in the diaphragm, making it correspond to the changed aperture.

As already noted, manufacturers usually make the objectives, in any given series, parfocal.* This means that when any one of them is in focus on an object, rotating any other mounted in the nosepiece, into position, places it approximately in focus without readjusting the tube, only a slight change in the fine adjustment being necessary.

But until one thoroughly understands the idiosyncrasies of his particular instrument and the various combinations of objectives and eyepieces, it is better not to presume too much that the parfocal characteristics will provide freedom from trouble. There is a con-

*See page 47.

siderable possibility that either the lens moving out of position or the one coming in may strike against a stage clip, a part of the mechanical stage, or even against a ringed cover on the slide, the result being a scratching of the front lens. Also, when high-power lenses are involved, they may be found to be perfectly parfocal with one ocular while with another, the higher-power lens may come so close to the cover as to strike it.

Also it often happens that a lens of a different series, or even of a different make, which is in no sense parfocal with others, may be in use on the nosepiece. In such a case, if one forgets the combination being employed and assumes a parfocal condition, severe damage may be done.

Parfocal lenses of 8 mm. focus ($20\times$) and under can always be rotated into position without danger of the front lens coming in contact with the slide, but even with these, one should always know what chance there may be for them to rub against clips or some portion of a mechanical stage in some positions of the latter. When swinging a high-power dry or an immersion lens into position, it is better practice to elevate the tube a slight amount, say about the thickness of a piece of paper. Then it can be focused down with the fine adjustment, until the image appears.

The fine adjustment of modern microscopes is so constructed that it does not apply screw pressure after the front lens makes contact with the cover glass, so that ordinarily no damage is done if one continues to rotate the adjustment screw after this point is reached. Some pressure, however, is present, due to the weight of the tube, and so reasonable care should be exercised not to continue turning the fine adjustment if there are any indications that the objective is touching the cover glass. Here, it should be mentioned that slides are frequently met with which have covers so thick that the short working distance of some objectives will not allow the object to be brought into focus. This condition is usually indicated by the object's coming only partially into view and then remaining stationary as the fine adjustment is operated downward. Another common indication, when the object is mounted in balsam or other fluid medium, is a shifting of the object or foreign particles in the mountant floating through the field as the fine focus is altered. When such a slide is

found, no further attempt should be made to use the short-focus lens on it. Either a lens with a greater working distance should be used, or the slide should be remounted with a thinner cover.

Before undertaking the use of an oil-immersion lens, one must be sure that he understands the purpose of the oil and the manner of its application. I have known of several instances where the oil was put into the top of the objective through lack of knowledge of its proper use!

As explained elsewhere,* the oil, which has a refractive index approximately the same as those of the glass of the slide cover and the front lens of the objective, is used to fill up the space between them, so that the light rays pass in straight lines from one to the other as though the entire space were filled with homogeneous glass. An oil-immersion lens will not function properly without this oil contact, nor, on the other hand, will a dry lens work with oil.

As the sole function of the oil is to provide a homogeneous medium, it is obvious that no air bubbles should be present between the lens and cover, for a single bubble will defeat the purpose of the oil. One of the most important points in oiling the contact, therefore, is to do it so as to eliminate all bubbles.

Oil bottles are usually provided with an applicator rod on the stopper, to which a drop of oil adheres when it is withdrawn from the bottle. A single drop of oil is ample for the contact, and it can be applied either to the cover or to the front surface of the lens. The latter is preferable, if it can be done before the lens is rotated into position, as the hanging drop tends to prevent air bubbles when it makes contact with the slide. In doing this, however, care must be taken not to scratch the front lens with the applicator rod.

After the oil contact has been made, it is better to use only the fine adjustment to secure the correct focus. If one has had no previous experience, the object chosen for the first trial should possess considerable contrast, preferably one deeply stained and with a very fine structure. At the start, the lowest power eyepiece should be used. An ideal object to practice on is a well-stained blood smear, with a leucocyte previously located in the center of the field by means of the

*See page 57.

next lower power objective. The centering of the lenses should be at least such that a minute object which is centrally located in the field with any one objective, will come within the field of view when the next higher power lens is substituted for it. Should this not take place, one or the other objective is poorly centered. As a matter of fact, most high quality lenses manufactured today are so well centered that one can go directly from a 16 mm. (10x) to the 2 mm. oil-immersion lens and expect to find the central part of the field common to both.

For a large percentage of high-power work, oil-immersion lenses can be used without oiling the condenser; the latter then works at a maximum numerical aperture of 1.00. When a dry condenser is focused on the plane of the object, as in critical illumination, and the diaphragm is wide open, on removing the eyepiece and looking down the tube, it will be seen that the back lens of an objective having a greater numerical aperture than 1.00 is not completely filled with light. Closing the diaphragm a considerable amount makes no difference in the size of the illuminated area. The latter remains the same until the iris diameter reaches an N.A. of 1.00, and then it starts to cut down. In other words, all the aperture in excess of 1.00 which has been built into the condenser is useless when it is used dry, and the effective aperture of the system is halfway between the N.A. of the objective and 1.00 — i.e., a 1.30 N.A. will give resolution equivalent to 1.15 N.A.

In the beginning it is easier for a novice to practice with an immersion objective, using a dry condenser, but as soon as this is mastered, an oiled condenser should be tried. Should the slide be in position and the immersion lens focused on it, oiling can be done by lowering the condenser or removing it so that the oil can be applied to the top lens. Considerably more oil should be used than for the objective in order that ample will be present if the focal point should require the condenser to be some distance away from the bottom of the slide. Condensers must be designed to function with fairly thick slides; hence, when a very thin slide is used the difference must be made up with oil. Should there be any difficulty in retaining sufficient oil in place, because of wide separation, a drop of oil should be applied to the condenser, then a small round cover glass placed

on top, and this in turn oiled to the bottom of the slide. If necessary, several cover glasses can be used with oil (and no air bubbles) between them.

When it is known beforehand that oil is to be used with a certain slide in order to secure maximum resolution, the oil can be applied to the condenser before the slide is put in position. As soon as one is through using an immersion objective (that is, for at least several hours) the oil should be carefully cleaned off it and the slide, and also from the condenser, if that is oiled. This can be done with a drop of xylol on a soft cloth or lens paper. Immersion oil becomes very gummy when exposed to the air for a short time and finally dries to a hard resin. For this reason the oil bottle should be kept tightly covered at all times except when oiling the lens or condenser. Although it may remain fluid, if it is exposed to the air for an appreciable time the refractive index and dispersion will change enough to affect the resolution.

Although most microscopical work is carried on through the study of transparent objects, by means of transmitted light, every microscopist should become familiar with the operation of the instrument in the examination of opaque objects, especially at low magnification.

When we use objectives with a considerable working distance, this type of microscopical work does not offer any serious difficulties. All that is necessary is either a fairly strong light source placed near the object on the stage, or a concentrated beam projected on it by means of a "bull's-eye" condenser. (A convenient form of the latter is shown in Figure 64.) The reflecting power of most materials requiring examination by reflected light is relatively low; this explains the need for a rather strong illumination, for the intensity of the light which reaches the eye varies inversely as the square of the magnification.

The light should strike the object obliquely at an angle of about 60° to the optic axis. This causes irregularities of the surface to stand out in relief, because of the shadows cast. The relief becomes increasingly less as the obliquity of the angle decreases; when a vertical illuminator (such as those employed for metallographic purposes) is used, the angle is zero and therefore no relief is apparent. For this reason any form of illumination which is projected on the

object parallel to the optic axis is unsatisfactory for most types of investigation.

A limit to the magnification which can be employed with ordinary microscopical equipment when using oblique reflected lighting, naturally exists, due to the need for ample working distance between the objective and the object to allow the light to strike the latter. Also, if high-apertured dry objectives are to be used for this purpose, they must be corrected for use without a cover glass if they are to be used on uncovered objects. With low-power lenses, up to 16 mm., the absence of a cover glass can be ignored.

For high-power work under oblique reflected light, special equipment is available. This phase of the subject will be discussed later.

II. Working Conditions and the Personal Equation

As soon as one has become thoroughly conversant with the manipulation of the microscope, before settling down to any intensive use of it he should make a study of the working conditions which seem best to suit his individual idiosyncrasies. If the highest quality of work is to be done and particularly if considerable time is to be spent in active use of the instrument, there are certain rules applicable to everyone which should be rigidly observed. For instance, it is highly desirable that one feel fresh and anxious to do the work. A tired or sleepy feeling, a headache, or consciousness of eyestrain, are not conducive to good work or enjoyment of the task. Under such conditions, unless it be absolutely imperative that a certain job be completed at once, it is far better to put the microscope away until a more auspicious occasion. On the other hand, when the worker feels as though he had rather look through his microscope than eat, sleep, or play golf, it becomes a pleasure and if his energies are properly directed, much definite work of a constructive nature can be accomplished.

Some authorities on the microscope attempt to outline ideal working conditions — the height of the table and the stool or chair, the inclination of the instrument, etc. — but careful consideration of these matters leads to the conclusion that individual ideas of comfort vary entirely too much to fit everybody into the same Procrustean bed. It is better to state a general proposition and then let each worker determine for himself just how he likes things to be. The broad rule

for the best combination of conditions is that the position, height, and inclination of the instrument, the height and design of the seat, the amount of light in the room, the temperature of the atmosphere, and every other factor under control should make for the maximum comfort of the individual. Some like a padded stool, some like a hard; some prefer it high, others low; still others desire a rotating chair or stool. It is not until after one has gained some experience in the use of the microscope that preferred working conditions can be determined. But as soon as one finds that the table is too high or too low, or the position cramped in any way, steps should be taken to correct the trouble. Always be comfortable while you are using the microscope if you wish to continue to enjoy it.

The inclination joint serves to compensate for a considerable variation in table or chair height when the object is such that the stage can be inclined. With some objects, however (notably fluids, hanging drop cultures, blood counting work, etc.), it is imperative that the stage be horizontal. There are three alternatives for meeting this condition: (1) use a low table and fairly high chair, (2) stand up to the microscope on a higher table, or (3) employ an inclined eyepiece. These latter are available as accessory equipment in both the monocular and binocular forms.

The latest tendency is to equip the higher class of instruments with inclined binocular eyepieces. As these are set at a fixed angle,* the relative heights of the table and chair are rather critical. The best combination should be determined to suit individual comfort. What will suit a short person will be exceedingly uncomfortable for a tall one. Figure 68 illustrates an ideal condition.

When the microscope is to be used continuously for a considerable period of time, a binocular eyepiece will prove far more comfortable and less fatiguing than a monocular. When there is no choice and the monocular must be used, eye fatigue can be reduced to a minimum by taking reasonable precautions.

The first of these is, *keep both eyes open*. It is almost universally the case that one eye seems more adaptable to microscopical use than the other; in some persons it is the right eye, in others the left. Rarely

*Spencer makes a stand in which the inclination of the eyepiece can be varied anywhere between zero and 40°.

will an individual be found who can use either eye indiscriminately. It is often urged that one should learn to use both, changing occasionally from one to the other to lessen fatigue. This does not seem to work with most people. Careful study usually reveals, however, that it is the eye that is *not* being used that becomes fatigued. The reason is that the eye which is in use is in a position of relaxation, the

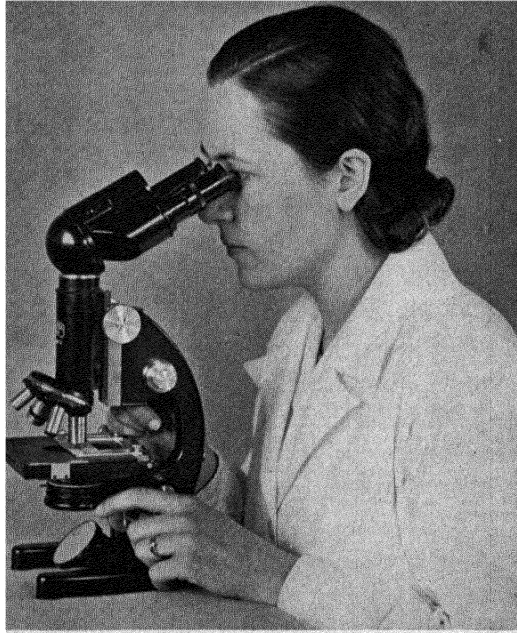

FIG. 68. Use of Inclined Eyepiece Making for Ideal Working Conditions
(Courtesy of Carl Zeiss)

ciliary muscles are not under stress, and — regardless of whether the eye be normal, myopic, or hypermetropic — the focus of the microscope is automatically adjusted to its position of best accommodation. The inactive eye tires because there is a strain on the eyelid muscles in keeping it closed while the other is open.

If, therefore, both are kept open, there is no undue strain, but the inactive eye should not be allowed to perceive light in a passive way (as sometimes recommended). There are two reasons for this. The first applies to everyone alike; it is impossible to concentrate on the

minute structure of the microscopical image when there is an appreciable quantity of light and an indefinite image superimposed upon it by the inactive eye, and so the best work cannot be done under this condition. The second reason is that, although it may work to a fair degree with an inactive hypermetropic eye which naturally accommodates at infinity, causing nearby objects to be absolutely out of focus and therefore objectionable only to the extent of the diffused light picked up, in the instance of strongly myopic eyes nearby objects within the range of the inactive eye are in focus — which of course means that two sharply defined but different images are transmitted to the brain simultaneously.

The solution of the problem is simple. While the unused eye is open, it must be shielded either with the hand cupped over it or with an eye shield. These latter are supplied by most manufacturers. The Bausch and Lomb model is shown in Figure 69. A simple homemade shield can be improvised out of black sheet celluloid or sheet metal.

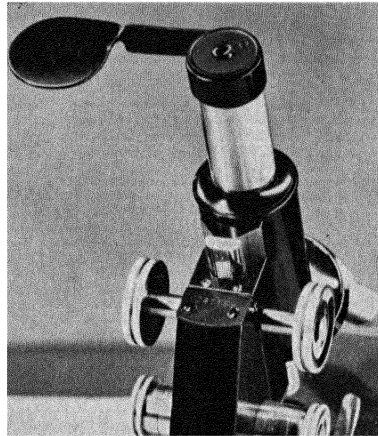

FIG. 69. Eye shield
(Courtesy Bausch and Lomb Optical Co.)

The question is often raised as to whether continued use of the microscope will finally affect the eyesight adversely. The answer seems to be that the contrary is true; the eye that is used for microscopical work is found, after some time, to be better than the other. Apparently the law of use and disuse operates with the eye as with other parts of the body. One caution should be observed, however; *do not employ a brighter light than necessary* to see clearly every detail — especially when there is any possibility of ultra-violet light being emitted by the light source (e.g., bright sunlight, an arc lamp, or quartz mercury vapor).

One may notice that, when working in a darkened room, the eye employed with the microscope is, after a time, almost blind when it is raised from the instrument. This is merely because it has become

relatively insensitive as compared to the inactive eye, and nature cannot accommodate for the difference by a variation in the size of the iris. The effect lasts only a minute or two and should not cause any concern.

III. The Approach to a Problem

The methods employed in microscopical investigations are frequently determined by the viewpoint of the individual. Broadly speaking, everyone working with a microscope can be classified into one of two groups, the amateurs and the professionals. The former are drawn to the instrument largely through its own lure; they are hobbyists interested in the unseen, minute world around them; the latter admit merely an incidental need for it.

The amateur is usually very general in his application of the microscope; he never tires of examining anything he can get on the stage. The professional is essentially a specialist, interested in one particular phase of microscopical work, sometimes even then only because he must employ it as a means to an end. This latter group is ordinarily constituted of medical workers (histologists and pathologists), biologists, metallurgists, chemists, petrographers, and the like.

The ideal microscopist (who is somewhat rare) is a combination of the two; he is either an amateur specializing intensively in one or more lines of research, or a true specialist possessing an innate love for microscopical work in his own particular field. Unless the amateur is definitely interested in some particular branch of microscopy, his problems are probably limited to those relating to the preparation of material, slides, etc., for study under the microscope, or the collection of suitable material. Even here his energies can be put to good use in the cause of microscopical science. There are many desired improvements in the technique of slide making, so that this in itself can become a specialization. Too often the amateur is content to generalize and get nowhere; careful search usually reveals that the reason is simply that he has not the requisite knowledge of how to go forward. This situation usually changes as soon as he starts to specialize.

Specialization, for the amateur, should always be along some line

which possesses a natural appeal for him. For instance, if he has found his greatest pleasure in the study of pond life — aquatic organisms or vegetative forms — there are many lines of research where definite contributions to biological science can be made. Thousands of new species, both plant and animal, remain to be discovered and described; the particular flora and fauna of localized areas need to be identified and tabulated; new methods of collecting, preserving, and mounting may be worked out; and many other bits of knowledge may be gleaned and publicized for the benefit of others.

The microscopical problems of the specialist vary as widely as the specialties themselves vary. To cover those of any single branch of microscopical investigation would require an entire volume; in fact, many have been written on such subjects as botanical micro-technique, animal and plant histology, micro-chemistry, metallurgy, petrography, and the like. In this work only such general principles as apply to all can be considered.

In occasional lines of investigation the microscope plays only a minor role; in others, it constitutes the only method of attack. For almost all cases, however, there exists a common starting point, for it is rare indeed that an object or material can be subjected to critical microscopical study without undergoing some preliminary preparation.

The preparation methods themselves will be considered in detail in Chapter 7; just now we are interested in the approach to the problem of determining what methods are to be employed in getting the material ready for examination. Sometimes it is obvious that only a single method is necessary; in other cases every conceivable means of study must be employed. Biological studies usually include examinations in the living state, when the organisms are minute, supplemented by permanent mounts showing the reaction of staining methods for differentiation of structures, and sectioning of larger forms and tissues for study by transmitted light.

On the other hand, metals can be studied only by observing polished and etched surfaces by incident light. The only important variations in this method of examination lie in the different etching methods for delineation of various constituents. It is obvious that between such widely diversified microscopical studies there can be

little in common except the need for a knowledge in each case of the proper means of preparing and studying the material.

Between these two extremes lie a large number of materials, the internal structure of which can be determined microscopically, provided that the microscopist has a knowledge of the methods to employ. These materials include practically everything found in nature or compounded by the art of man. Some are as opaque as metals, and possibly as hard; others are opaque in the mass but translucent or transparent in thin section; some can be sectioned in a microtome while others must be ground thin; some can be differentiated by staining, others cannot.

It is apparent that some preliminary knowledge of the nature and characteristics of a material must be obtained before the best methods of proceeding with any microscopical examination may be attempted. Once this is gained, we are ready to go ahead. To this end, such questions as the following will usually indicate the proper procedure of preparation:

(1) What can be learned from a surface examination by incident light?

(2) If the exact nature of the material is unknown, are there any superficial indications as to whether it is organic or inorganic?

(3) Are there any superficial indications as to whether the material is a natural or artificial product?

(4) Is the material opaque in thin section or will it transmit some light?

(5) Is it soft enough to cut with a knife or must it be ground?

(6) Is it obviously non-homogeneous or possibly homogeneous even at high magnification?

(7) Is there a possibility of translucent, apparently homogeneous material being colloidal in nature?

(8) Can it be crushed for examination as powdered material?

(9) Am I interested in it as to its constituents only, without regard to their relative arrangement, or should I know also the relative arrangement of different constituents?

(10) In how many different ways can the material be studied, with a view to co-ordinating the results?

(11) Is it too friable in nature to permit sectioning by grinding, or too soft to section by the microtome without embedding?

(12) Should it be examined under very high or only low magnification, and what methods of preparation would be best suited for the magnification to be employed?

(13) If there be insufficient natural differentiation of various components, can differentiation be secured by artificial means — staining, chemical reaction, heat tinting, etc.?

(14) Will the material, either by surface reflection or by transmitted light, polarize light?

(15) What mounting media are best suited to accentuate differences due to the refractive indices of constituents?

(16) Would a study of the material by special lighting, ultra-violet, infra-red, the sodium D line, or a narrow band yield additional information of value?

(17) Can anything be learned about the material by the way it reacts under temperature variations during examination?

(18) What might be learned about the nature of the material by chemical reactions under the microscope?

(19) In the case of hard or brittle material, can it be changed by proper chemical treatment to permit sectioning with a knife, without affecting the microscopical determinations?

(20) Is there any possibility of any fluid used in the preparation of the material for examination or the mounting medium possessing a solvent action such that the true nature of the original material might be altered and a false conclusion drawn?

These represent the type of questions to be considered in determining the course of preparation and the line of investigation at the outset. Preliminary work will often raise other questions and suggest an entirely different line of attack. Difficulties encountered in one direction must be surmounted by changes of procedure until one is satisfied with the results obtained.

One word of caution should be given as to the likelihood of false conclusions being drawn as a result of artificial conditions produced in the preparation of material. Such conditions are commonly known as *artifacts*. The presence of artifacts in microscopical preparations is extremely common. They range from shrinkage, expansion, artificial voids and cracks to the presence of foreign material which simulates a natural constituent. Ideal preparation of material attempts to reduce artifacts to a minimum; but, granting their occa-

sional presence, the proper procedure in completing a microscopical study is first to recognize them and then ignore them in drawing conclusions.

The drawing of conclusions is the ultimate purpose of all microscopical investigations. It is only as these conclusions represent the facts that they are of value; therefore, no investigation should be assumed to be completed until the worker is sure that his determinations are correct.

IV. Apparatus and Technique for Special Purposes

Advanced microscopical work inevitably calls for specialized technique and additional apparatus to supplement the instrument itself. Some of this apparatus may be considered as items of convenience only; other accessories are absolutely essential to the accomplishing of certain results. Then again, some operations which can be performed with standard microscope equipment are unfamiliar to many microscopists because they have never had occasion to employ them.

Measurements

One of the problems most frequently encountered is the determination of lengths and thicknesses under the microscope. When the instrument is equipped with a graduated mechanical stage and the dimensions of the object are not too minute (about 100 microns), fairly accurate results can be obtained without the use of stage and eyepiece micrometers, by utilizing the stage graduations and vernier. This is done by using one edge of the field (if no cross-hair or equivalent eyepiece be available) as the index line, bringing one end of the object to be measured into coincidence with it, taking the vernier reading, then moving the stage until the other end reaches the index edge of the field and taking a second reading. The difference between the two readings is the actual length of the object. When the size of an object extends over the diameter of a field with a low-power objective, this is the best way to measure it. Should a centrally placed index be desired, it can be improvised by cutting a thin, sharply pointed indicator from metal or a card and mounting it with any suitable adhesive within the eyepiece so that the point will be centrally located and lie in the plane of the diaphragm. Such an

eyepiece will serve many purposes as a pointer eyepiece. They are, of course, available as standard equipment.

It is possible to obtain an approximate idea of the dimensions of fairly small objects by means of the mechanical stage vernier when they are too minute to secure a direct vernier reading. To do this, it is merely necessary to measure the diameter of the field of view with a given combination of objective and ocular. To do this, select some spot in an object as a reference point, and move it across the field from edge to edge, taking the readings at each extreme. Suppose that such readings, as accurately as they could be taken, showed $\frac{1}{8}$ of a millimeter (100 microns) as the diameter of the field, then an object which extended one-quarter of the way across would be 25 microns in length. With practice, one-tenth of the field diameter can be estimated fairly accurately and the order of magnitude of an object visualized far beyond this. This is illustrated in Figure 70.

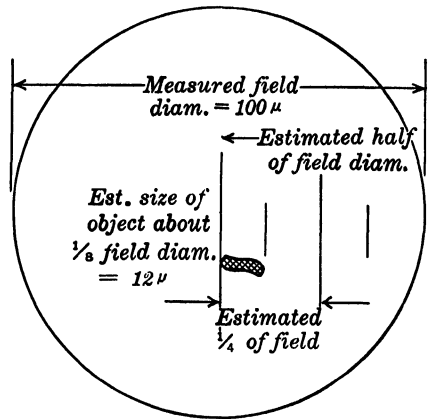

FIG. 70. Measuring the Size of an Object by Proportion of Field

When more precise measurements are desired, two additional pieces of equipment must be available. These are a stage micrometer and a micrometer eyepiece. The former is in the form of a standard $3'' \times 1''$ glass slip with accurately ruled lines, usually two millimeters divided into hundredths of a millimeter. This is in effect a microscopic ruler, but as it cannot be laid directly on an object for measurement purposes, its use is limited to the calibration of an arbitrary set of lines capable of being directly superimposed on the object. This latter is accomplished by having the arbitrary rulings located in the eyepiece, on the plane of the diaphragm.*

The eyepiece, so equipped, is known as a micrometer eyepiece. The simplest form available is a glass disc with the rulings engraved

*See also Eikonometer, defined in the Glossary.

or photographed on it, which can be laid on the diaphragm (with the scale side downward, so as to lie in the exact plane of the diaphragm). It can thus be used with any power standard eyepiece, but it will usually be found that the position of the diaphragm must be altered slightly, up or down, in order to bring the scale into sharp focus.

Because of the difficulty of getting the scale into ideal focus in standard oculars, it is preferable to use a special type having a focusing eye lens. When the lines in the eyepiece are sharp, they always appear directly superimposed on any object in the field. They are, however, meaningless in so far as measurements are concerned until they have been calibrated with a stage micrometer. This is done by focusing on the stage micrometer, with the micrometer eyepiece in place and noting the length (in mms.) included in the entire eyepiece scale. This figure, divided by the number of divisions in the eyepiece scale, gives the value of one scale division. For instance, the entire scale is found to be equal to .79 mm. (i.e., 790 microns). Then if there are 50 divisions in the eyepiece scale, each division equals $\frac{790}{50} = 15.8$ microns.

For maximum accuracy, especially with extremely minute objects at high magnification, the filar micrometer eyepiece should be used. The principle is identical, but the reference lines in the eyepiece scale are subdivided by a movable hair line actuated by means of an external drum graduated into 100 parts, so that very small values may be accurately ascertained and read from the drum. The filar micrometer must, of course, be calibrated with a stage micrometer, in the same manner as a simple micrometer eyepiece.

Occasionally one is called upon to make another type of measurement under the microscope, i.e., the thickness of a transparent object or section. With modern instruments, this requires no additional equipment, but it does involve greater skill on the part of the operator. The fine adjustment is graduated to show vertical travel and thus constitutes the measuring device. Measurements of this kind must be made with a high-power objective, preferably about a 4 or 3 mm. with an aperture of at least .85 N.A. so that the optical plane of focus will be sharply defined. The procedure is to find some field where the exact focus on both the bottom and the top surface of the object can be determined. Usually this is not difficult to do as there are com-

monly some minute particles or structural details on both surfaces to focus on. After the particles to be used for the purpose have been selected, the number of scale divisions on the fine adjustment passed through in going from one position of focus to the other should be determined. It is necessary to know the value of the scale divisions. For instance, if each division equals 2 microns and if it is found that there is a difference of 10 divisions between the two focal points, the total movement of the fine adjustment has been 20 microns. But this is the actual distance between the two positions only when the medium between them is air, which has a refractive index of 1.00. In order to determine the true distance, the movement of the fine adjustment must be multiplied by the refractive index of the medium between the top and bottom focus. If it be balsam, the figure of 20 microns must be multiplied by 1.53, giving the actual thickness as 30.6 microns.

The errors introduced in this type of measurement are greater than when measuring transverse dimensions, but when the operation is repeated several times and an average taken, it should be fairly accurate. Variations from the assumed refractive index do not affect the result to the same extent as errors in determining the exact top and bottom surfaces.

Counting Methods

Another operation which must be performed frequently under the microscope is the counting of particles. Two cases are possible — one involves the particles present in a single layer only, e.g., a smear or a section, and the other, the particles present in a given volume of fluid or weight of material. Where only a few particles (this term, in a general sense, includes anything requiring counting) occur scattered over an entire slide in a fixed layer, the mechanical stage can be used to traverse the entire area, recording the count as the particles come into view; when a considerable number are present in any given field, the use of a net ruling in the eyepiece is desirable. This can be mounted in a micrometer eyepiece in place of the scale. The counting can be either a complete count of an entire slide or a count of all the particles within the areas embraced in several net rulings and the average taken as the number per unit of area of the size taken as standard. When a large number of particles are present, the unit

taken may be a single square in the net ruling. The count for the entire slide will then be the number per unit of area multiplied by the number of unit areas in the slide.

The counting of particles in a given volume of fluid (blood cells, etc.) is similar in principle except that in addition to surface dimensions we must also include depth. Various types of counting chambers and cells for this purpose are on the market. These are net ruled directly in millimeters (and subdivisions thereof) and are of a definite depth so that when fluid is placed in the cell or chamber and a flat cover glass placed over it, the amount of fluid enclosed within a square is a definite part of a cubic millimeter. For instance, suppose the side of a square be $\frac{1}{20}$ of a millimeter and the cell depth $\frac{1}{10}$ of a millimeter, then the volume is $\frac{1}{20} \times \frac{1}{20} \times \frac{1}{10} = \frac{1}{4000}$ cubic millimeter. If four particles proved to be the average per square, the number per cubic millimeter would be $4 \times 4,000$ or 16,000.

The number of particles per gram of powdered material can be derived in the same manner by making a suspension in a fluid (castor oil is one of the best) in a definite ratio of one gram of powder to a given number of cubic centimeters of fluid (100 or 1,000), depending on the fineness of the particles. Suppose the dilution has been 1 gram in 1,000 cc. (it is not necessary to mix this quantity, but only in this proportion; the amount of fluid depends on the sensitivity of the scales used in weighing the material, a few milligrams usually sufficing), then the number of particles per cubic millimeter multiplied by 1,000,000 (cu. mms. in 1,000 cc.) gives the number of particles per gram of powder.

Marking Objects for Future Reference

It often happens, in examining permanent mounts, that some object of interest is found that may require future study. Its position must then be marked in order to locate it quickly at any subsequent time. Many workers do this by placing a drop of ink on the cover as close as possible to the object, watching the object and pen point in the microscope while it is being marked.

There are several methods of greater precision and readier relocating with which it is desirable to be conversant. Where a graduated stage is available, it suffices merely to record the position of both the

vertical and horizontal verniers to enable it to be relocated on the same instrument. If it is expected that the object may be studied later with a different instrument, a diamond marker is ideal. This device, shown in Figure 71, screws onto the nosepiece in place of an objective. Consequently, when it is thrown into position it is centered over the object. It is then lowered and the diamond point is rotated one complete revolution, thus marking a minute circle (the size of which can be adjusted) around the object.

Another piece of equipment for locating objects is the Maltwood finder. It is a standard $3'' \times 1''$ glass slip with a photographed network on it, the net spaces each bearing a serial number. In order to use it, one condition must be met; there must be some means of setting both the finder and the slide in a fixed position on the stage. A mechanical stage is satisfactory, or even a metal *L* which can be clamped on the stage. Any other device which will allow the finder and slide to be placed on the stage so that their lower edges and one end will register together, will be satisfactory. To use the finder, it is then merely necessary to remove the slide, after the object to be recorded has been centrally located in the field, and substitute for it the finder. A number will be seen in the field and this number, with its exact position in the field, may be recorded.

When it is necessary to examine the object once more, the finder is first located so that the number shows up as recorded, then the slide is substituted in the same position and the object desired will be found in the center of the field.

Demonstration and Comparison Work

When it is desirable that two workers study a preparation simultaneously, or one observe the comparative appearance of two different objects in juxtaposition, specialized equipment to accomplish these ends must be available. The demonstration eyepiece, the Zeiss model of which is shown in Figure 50, divides the image from a single microscope in such manner that the same field can be seen through



FIG. 71. Object Marker
(Courtesy E. Leitz)

two separate eye lenses. This is a great convenience when two individuals are interested in the same problem and wish to compare notes as to what they are looking at. It also greatly facilitates teaching, as a pointer is either provided in the demonstration eyepiece or some form of pointer eyepiece can be used in conjunction with it.

The comparison eyepiece, shown in Figure 51, is practically the reverse of the demonstration eyepiece in that it receives images from two different microscopes and combines them into a single eye lens, one-half of the field showing one object and the corresponding half the object from the second instrument. This, of course, necessitates not only the special eyepiece being available, but also a second microscope with a duplicate set of lenses. Nevertheless, where considerable comparison work must be done, it is of great value, for the only substitute is a duplicate set of photomicrographs of the objects to be compared, taken under identical conditions, and even in these some subtle differences may escape notice.

Drawing, Projection, and Photography

Sooner or later, every seriously minded microscopist reaches the place where he wishes to reproduce what he sees in the instrument. This must naturally be accomplished in one of three ways, by drawing, photographing, or projecting. The first two provide permanent records for future use, the last merely reproduces the image for the transient interest of others.

Although freehand drawing can be done by anyone with the requisite artistic skill, fortunately it is not necessary for one to be proficient in drawing in order to produce accurate copies of a microscopical image. Two methods are available to simplify the work. The older, and at one time the common one, is the use of the camera lucida. This is made in several designs, ranging from very simple to complex. The principle is always the same — a device attached above the eyepiece which reflects a superimposed image of a sheet of paper and the pencil point on the microscopical image. Both are seen when one looks into the microscope. It thus becomes a simple matter to trace the outline of the microscopical object by observing the movement of the pencil point.

The fact that a real image of the microscopical object is projected,

without the aid of any equipment other than a brilliant source of illumination, directly by the eye lens onto a screen located behind it, makes possible not only projection and photographic reproduction, but simplifies drawing as well, and obviates the need for a camera lucida for this latter purpose. Moreover, the projected image on a screen located ten inches from the eye lens (the Ramsden circle or eye point, to be more exact) is the exact magnification of the microscope, hence drawing to scale is easier. In projection, which can be at any reasonable distance, if the light is ample, it is usually preferable to place the microscope in a horizontal position. When the distance between the screen and microscope is great enough to allow working between them, drawing paper can be substituted for the screen and the outlines traced directly. A more convenient method, when the image is to be projected for drawing purposes, is to employ a 45° reflecting prism over the eyepiece so as to project the image downward onto a horizontal surface. The exact ratio of the size of the image to the magnification employed, is the ratio of the distance between the eyepiece and paper to ten inches. At five inches it is one-half size, at twenty inches it is twice the actual size.

A reflecting prism also serves to project horizontally with the microscope in a vertical position, as it must sometimes be when examining liquids.

A complete discussion of photomicrography (or sometimes simply "micrography," the terms used to designate the taking of enlarged photographs of minute objects through the microscope) would require an entire volume. Here we can give it only passing notice.

It will be apparent, inasmuch as the microscope can project an image which can be seen on a screen, that if a sensitive plate or film be substituted for the screen and all extraneous light excluded, a negative can be secured. In other words, reduced to its simplest elements, photography with the microscope involves only a camera, minus a lens, connected in a light-tight manner to the eyepiece so as to allow the image to fall on the film. Actually, one other condition must be fulfilled: there must be some means for focusing the image on the focal plane of the camera, for the point of best focus will not be identical with the best visual focus. A camera with a ground-glass focusing screen is ideal.

Complete photomicrographic equipment, ranging from extremely simple to very elaborate, is available from all microscope manufacturers. If one contemplates serious work, the commercial product is to be preferred to homemade apparatus. However, very good work may be done with improvised outfits, especially by those gifted with the ability to construct and operate them.

Accentuating and Suppressing Contrast

The range in the type of objects subjected to microscopical study inevitably introduces a wide variation in the degree of light transmission encountered. Especially is this true when further complications are introduced by various techniques employed in mounting the objects for examination. Some may become almost invisible in the mounting medium, other constituents may be excessively dark; some may refuse to stain, while others absorb almost any color with avidity. It is obvious that the problem of accentuating and suppressing contrasts ties up in many respects with mounting technique, for both temporary and permanent preparations. In so far as this is true, this phase of the subject must be considered later, in connection with the preparation of material.

But assuming that the utmost care has been taken in making the mounts, and yet there are objects or structures that remain almost invisible and others that are extremely dense, the problem then becomes one of manipulative technique in examination. Knowledge of the reason for the condition will often suggest a method for meeting it.

Objects which are practically invisible in mounting media of almost any sort are usually colorless, transparent, and possess a refractive index of the order of 1.45 to 1.55. Many such cannot be stained; others cannot be mounted dry.

In spite of these handicaps, several possible methods of examination are available for making the structure of such objects evident under the microscope. The simplest is a reduction in the aperture of the illumination cone, i.e., closing the substage diaphragm so as to accentuate any slight differential between the refractive indices of the object and mountant. Plate II shows the effect which can be secured in this manner. The material is a fibrous talc, colorless and

perfectly transparent, with refractive indices of 1.539 (α) to 1.589 (γ), mounted in balsam (R.I. 1.53).

By employing the Becke test, it can be ascertained whether the index of the material is higher or lower than that of the mountant. This is done as follows: With a narrow cone of light, first focus as carefully as possible on an edge of the object or particle which is approximately vertical (i.e., parallel to the optical axis of the microscope). Then watch the appearance of this edge while *raising* the focus. A hazy white border will form and, if the index of the object be higher than that of the mounting medium, it will move inward toward the center of the object as the focus is changed. When the index of the mountant is higher than that of the object, the reverse is true; the white border moves out from the edge. With this test as guide, it is often found that remounting more of the material in another mountant providing a greater spread between their respective indices is warranted.

In every case where the contrast is low, polarized light (to be discussed later) * should be tried, for many objects possess some degree of birefringence and often a great brilliance results. A typical case in point is that of various vegetable fibers — cotton, linen, etc. — which when unstained are almost invisible in balsam but are gorgeous in color under polarized light.

Several other special effects can be tried out to advantage with objects of low contrast. Among these are Rheinberg illumination, dark field, and fluorescence under ultra-violet light. The former is provided by the insertion of bicolored discs under the condenser. These are available in various combinations — blue with red center, red with blue center, etc.; the center portion illuminates the field and the border illuminates the object. It is substantially a modification of dark field, which will be considered under a special heading.

Ultra-violet fluorescence under the microscope is receiving considerable attention of late. It requires a special ultra-violet light source and filters, and also in many cases special impregnation with differential fluorescent fluids, although some materials are naturally self-fluorescing. The number of substances which fluoresce, or can be made to do so artificially, is naturally quite limited.

*See page 187.

When there is a slight shade of color present in objects with low contrast, complementary filters can be resorted to with advantage. For instance, some possess a faint yellow tinge. A deep blue filter placed in the light path will materially darken the object. Conversely, a bluish object can be made to stand out by the use of a yellow or red filter. Green is accentuated by red and red by green.

The use of filters is equally valuable when the purpose is to suppress contrast, especially with deeply stained objects. For this purpose, the filter chosen should be as near as possible of the same transmission (color) as the object whose color is to be suppressed. The Wratten (Eastman) set of nine color filters is a highly desirable addition to every microscopical outfit.

It sometimes happens that a thin section of some material is still so very dense as to appear almost opaque under ordinary methods of illumination. Instances of this can be found in sections of coals, lignite, etc. In such cases it often helps to choose first a lens combination which will not allow any clear field around the object and then employ an extremely powerful light source, such as an arc, or a 500 or 1,000 watt concentrated filament lamp. The sections then become quite translucent, or rather, the percentage of transmission with the strong light intensity is sufficient to register on the retina. Plate III shows a ground section of lignite which is almost opaque under a light ample for most microscopical work.

Optional Sectioning and Depth of Focus

The relation between depth of focus, optical section, and numerical aperture has already been pointed out. It yet remains to consider the practical application of the various possibilities resulting therefrom in everyday investigations. Instances are constantly arising where the utility of an extremely thin optical section is obvious. But just as often the opposite is the case; an optical section is not desired, but rather a view which will show an object of considerable depth in substantial focus simultaneously. It is true that continual focusing up and down while the image is being observed, when conditions call for depth of focus, will effect a partial compromise in visual work, although useless for photography. Assuming that a battery of lenses

is available for accomplishing the desired end directly, it is far better to employ a combination especially suited to the purpose.

Bearing in mind that the depth of focus is greatest with the lowest N.A. and decreases as the latter is raised, the choice of objective to be used may be easily made. If the use of a lower aperture involves employing a lens with less initial magnification (as will frequently be the case), this can be met to a certain extent by higher eye-piecing.

As illustrations of the differences in appearance between an appreciable depth of focus and shallow optical sections, see Plates IV, V, VI, VII, and VIII. Plate IV is a micrograph of a diatom frustule *Triceratium*, as commonly cleaned and mounted for test purposes. Only the outer siliceous shell is left, although there are naturally present a top and bottom valve. By the use of a fairly high aperture, when the top valve is in focus there is no indication of the one underneath; it is completely out of focus and so diffused that no evidence of it remains.

Plate V shows a *Triceratium* carefully fixed, stained, and mounted to reveal the inner protoplasmic contents of the cell, exactly as in the living condition. By the use of a lower aperture and a compromise focus, we now see not only the faint indication of the valve markings but the inner nucleus, plastids, and protoplasmic strands.

Plate VI gives an optical section through the nucleus at the level of the nucleolus without any indication of the presence of the upper and lower valves, while Plate VII shows an entirely different aspect of the nucleus resulting from a very slight change in the focus.

The nature of the markings on diatoms has long been a controversial subject among microscopists. What structural peculiarity in the frustule can account for the surface appearances and changes which take place as the focus is altered? Are the so-called "dots" holes or are they elevations? Undoubtedly the structures vary greatly in the different species but the question can be answered with certainty providing we can procure a transverse section through the valve. This has been accomplished *optically* with a *Triceratium* in Plate VIII. This represents an optical sectioning problem of the greatest possible magnitude, for the entire valve is present in vertical position both above and below the plane of focus and cannot but

affect the image to some extent. Nevertheless, the honeycomb structure, open internally, and the amoeboid-plastids within the cells, are clearly evident.

Another instance of similar structure as revealed by optical section is shown in Plate IX. This is from a section of a rock known as "Cementstein," a sedimentary deposit in which diatoms are frequently embedded. The rock section itself is far too thick (about 30 microns) to reveal the nature of a diatom frustule, but by choosing a specimen in a vertical position we can do the same as we did in taking Plate VIII, although in this case, it must be remembered, all the substance surrounding the frustule is solid rock. The nature of the diatom wall is seen to be very similar to that of the *Triceratium*.

Instances of the use of optical sectioning could be multiplied almost *ad infinitum*, but enough have been given to show its value in interpreting microstructures. When we add to the sectioning method the change in focus which can be made, it is apparent that ample serial sections can be taken to construct a complete mental picture of the nature of the object under examination.

Magnification vs. Resolution

It must not be overlooked, when employing objectives of various apertures, as suggested in connection with the securing of greater depth of focus, that although equivalent magnification may be obtained with higher eyepieces and lower initial magnification, it will be at the expense of resolution. As resolution is directly related to numerical aperture, a reduction in the latter, even with the same initial magnification, results in a decrease in resolution.

Just because a given lens combination will reveal structure — e.g., resolve the markings of a certain diatom — does not mean that it cannot be better resolved at the same magnification with an objective of higher aperture. A comparison of Plates X and XI, showing two views of *Navicula lyra* at 1,000 diameters, will make this point clear.

As long as this is constantly borne in mind, in conducting any microscopical examination one should feel free to use such lens

combinations as seem best to fit the situation, for it must be recognized that sometimes issues, other than resolution, may be paramount.

Dark Field Microscopy

The subject of dark field microscopy is extensive in its application and much could be written on it, far beyond the scope of this volume. However, a simple statement of the fundamental principles involved will go far toward giving a true conception of its practical utility and the means for securing dark fields.

As dark field condensers have been developed largely for high-power work, as a modified form of the slit ultra-microscope, the general conception is that dark field is applicable for this type of service only. This is far from correct; dark field has a place in low and medium magnifications as well. Moreover, it is very simple to employ and no special condenser is necessary unless high magnifications are also required.

When the nature of critical illumination is understood, it becomes a simple matter to appreciate the slight change which will convert it to dark field. Figure 72 (A) shows the path of the cone of light under

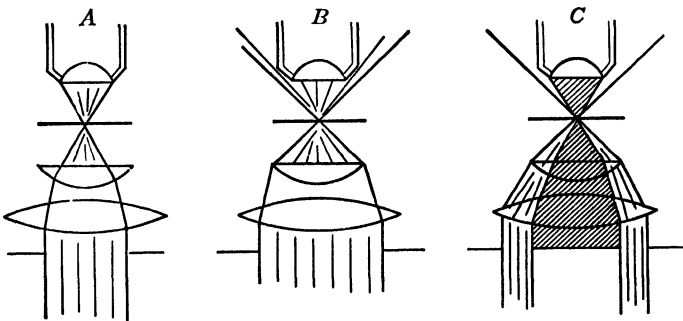

FIG. 72. Relation between Light and Dark Field Illumination

A. Critical illumination. B. Illuminating cone in excess of critical illumination. C. All direct rays producing critical illumination stopped out, only excess angle rays striking the object.

the condition of critical illumination. No light goes through the condenser that does not enter the objective. At B is shown the effect of opening up the condenser beyond the amount which matches the objective. Here the outer portion of the illuminating cone does not

enter the objective; no increase in the field intensity is evident, although, as we pointed out in the discussion of critical illumination, a marked fogging of the image takes place. At *C* is shown the result when all of the central cone of light which the objective will accommodate is blocked off by an opaque central shield. Under this condition, when no object is in the field no light will enter the objective and the field will appear dark.

This is the condition present, regardless of the type of special condenser used or the exact manner in which it is accomplished, when dark field is employed. With such a set-up, if now we place an object in the field, the oblique rays which do not enter the objective illuminate the object and it therefore stands out brilliantly lit up on a

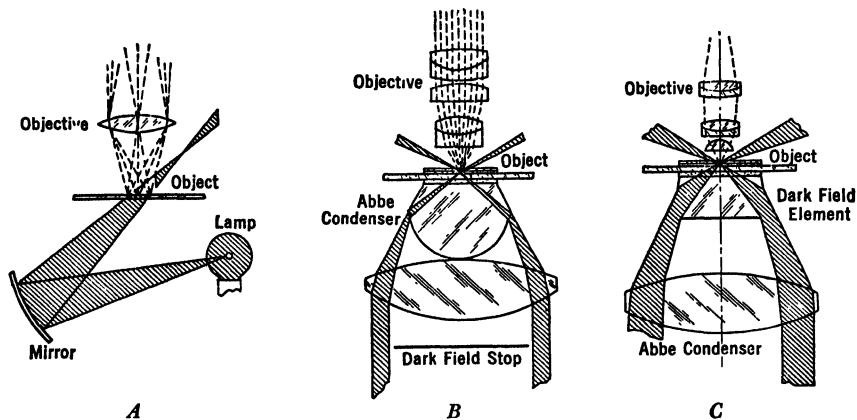

FIG. 73. Application of Dark Field Principle

A. By oblique rays from concave mirror. *B.* By dark field stop under condenser. *C.* By special dark field condenser top lens.

(Courtesy of Carl Zeiss)

dark background. It is analogous to spotlighting of buildings at night, except for the fact that the object lit is transparent. Incidentally, it is the superposition of this indirect lighting on an object in bright field, when the diaphragm is opened in excess of critical illumination, which causes the fogging of the image. In other words, direct lighting and dark field illumination do not mix.

From this we derive the simple rule for obtaining dark field at any magnification with a set-up as for critical lighting. Block off the

central cone with a circular stop of such size that no direct light enters the objective, then be sure that an ample hollow cone of light of greater aperture than the objective can pass to the object around the stop. Stops of various sizes, such as shown in Figure 74, are usually furnished by the manufacturers, or they can be cut from cardboard or metal of the proper dimensions to slip beneath the condenser.



FIG. 74

The special dark field condensers furnished by the microscope manufacturers are of various optical designs and vary in the extent to which they focus at a sharp point or over a greater depth, but all are intended for use at fairly high magnification. They find their greatest field of usefulness in the study of unstained bacteria in hanging drop cultures or fluids, minute living organisms, colloidal particles, etc.

Until recent years the highest aperture of objective which could be used with dark field condensers was N.A. 1.00; consequently, when oil-immersion lenses of higher aperture were to be used for dark field work it was necessary to introduce a stop into the back of the objective to reduce its aperture to below N.A. 1.00. This is still necessary with most condensers, but there are now on the market condensers of so wide a maximum aperture that they can cut off a cone of N.A. 1.30 and so are satisfactory for use with all objectives except those apochromats exceeding N.A. 1.30.

There are, however, inherent limitations which circumscribe the use of wide-apertured dark field condensers. The only illumination which can reach the object is that beyond the cone limited by N.A. 1.30; therefore the refractive index of the mounting medium in which the objects lie must be sufficiently high to transmit a cone considerably in excess of N.A. 1.30. The lower limit for the index of such a medium is about 1.45 and it should preferably be as high as that of the glass slip (1.52). It will be apparent that living bacteria in

aqueous solutions and fresh blood (or any similar material in body fluids) cannot be examined by means of these condensers.

Also, the object slide must be kept quite thin, as the maximum thickness through which the condensers can focus is about 1.2 mm.

Plates XII, XIII, XIV, and XV show applications of dark field at various magnifications and with diversified subjects.

Polarized Light

Ordinary light vibrates in all planes about the axis of propagation. Polarized light differs from ordinary light in that it has been made to vibrate in one plane only.

To illustrate what happens when light is polarized, suppose we could look along the axis of an oncoming ray of ordinary light and observe the planes of vibrations. The appearance would be as in Figure 75 (A), the vibrations lying in every possible azimuth. When light is polarized by any of the known methods, the vibration directions are caused to change so that they are in two directions only, at substantially 90° to each other, as shown at B in Figure 75. To

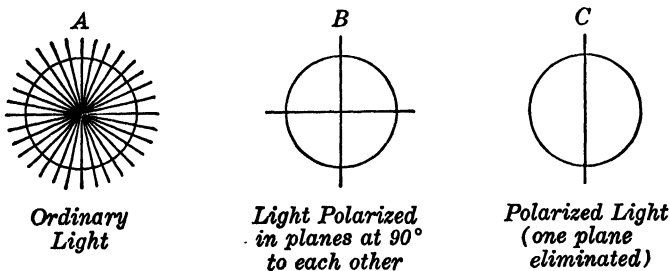

FIG. 75

utilize polarized light it is then necessary to eliminate one set of these rays so that only light vibrating in one direction, as at C, remains. To the unaided eye, no apparent change has occurred in the nature of the light itself, although its intensity has been reduced.

Polarization is brought about in several different ways, all of which have been utilized in connection with microscopical work. These are: first, by reflection from a polished surface; second, by repeated refraction at an angle through several thicknesses of thin glass; third,

by the use of specially constructed prisms made of calcite (usually spoken of as Nicol prisms, although there are many different types, only one of which is the true Nicol prism); and lastly through absorption with certain birefringent crystals such as tourmaline, which allows only rays vibrating in one plane to pass. To this last group belong certain sheet products recently put on the market which employ herapathite (iodosulphate of quinine), a chemical crystal possessing marked absorption properties.

To outline the theory and operation of polarized light is beyond our scope, as these can be studied in textbooks on physics and other specialized works.* But of practical interest to the general microscopist is the fact that polarized light is a tool of great value in many lines of study and an aid in determining the nature of many substances. For this reason every microscopist should possess a polarizer and analyzer, properly fitted to his instrument. The polarizer and analyzer are essentially similar in nature; both polarize light. The former is placed in the substage, preferably beneath the condenser so that all light reaching the object is polarized. The analyzer must be mounted above the object, almost invariably above the objective so that its presence will not interfere with the use of high-power lenses with short working distance. Its exact position above the objective is not so important; it may be directly above it, screwing into the nose-piece, mounted in the tube or within the eyepiece, or as a cap analyzer over the top of the eyepiece. However it is mounted, provision is usually made for rotating it at will, although rotation of the polarizer can be substituted if desired.

As both the polarizer and analyzer pass light vibrating in one plane only, it will be evident that when their vibration directions are parallel, whatever light passes through the polarizer goes straight through the analyzer also without undergoing any further change. Should the vibration direction of the analyzer be turned 90° to that of the polarizer, none of the light passed by the latter can get through the analyzer; consequently, even with a bright light projected into the microscope, none of it reaches the eye and the field appears dark.

The usefulness of polarized light in microscopical investigations lies in the fact that so many different materials polarize light to some

*Johannsen's *Manual of Petrographic Methods* is especially recommended.

degree. The property of polarization is due to birefringence, that is, the property of resolving light rays into two sets of vibrations at right angles to each other, the refractive indices for the two directions of vibration being different. Substances which polarize light include all crystals except those in the regular or isometric system, wood, fibers, bone, muscle cells, chitin, keratin, amorphous materials under strain, and numerous others to some degree. Those which do not polarize include crystals in the isometric system and amorphous substances of all kinds — e.g., glass, opal, resins — and also most liquids when free from chemicals which rotate the plane of polarization.

With these two groups in mind, we can see that when a nonpolarizing object or material is placed on the stage with the polarizing prisms in the crossed (i.e., 90°) position, nothing happens; everything in the field is dark. But now let a polarizing material — say, a crystal of some birefringent chemical — be substituted for it. The parallel polarized light from the polarizer which strikes it is repolarized in two directions, corresponding to the vibration directions of the crystal.* These repolarized rays on striking the analyzer are not all suppressed, but again repolarized so that some light passes through to the eye, the object thus becoming visible. But the light is no longer white light, for the rays vibrating in one direction have been slowed up more than those in the other plane at 90° to it, by the higher refractive index; hence, when they are again brought into the same plane by the analyzer, those wave lengths which have been retarded one-half a wave length interfere with each other and cancel out.

*When the two vibration directions in a birefringent crystal under examination exactly coincide with the vibration directions of the crossed prisms — which, in a complete rotation through 360° will occur four times, i.e., once every 90° — there is no repolarization and the crystal becomes dark. This is known as the position of extinction. In the tetragonal, hexagonal (rhombohedral), and orthorhombic systems the extinction directions are symmetrical with respect to the crystallographic axes, and hence such are said to possess parallel extinction. In the monoclinic and triclinic systems the extinction directions lie at an angle to crystallographic directions, and hence these are designated as possessing oblique or inclined extinction. Thus the extinction directions can be used to determine between these two groups of crystallographic systems.

Midway between two extinction positions — i.e., at the 45° position — the interference colors are at a maximum. When polarized light is employed with a non-rotating stage the object itself should always be rotated through at least 45° in a preliminary examination, as otherwise it might be assumed to be nonpolarizing when as a matter of fact it was by chance located on the stage in the position of extinction.

Therefore, some wave lengths are missing and the light that gets through is colored as a result.

Polarization effects are among the most beautiful sights which may be seen through a microscope, and so are worth while to secure, even from the standpoint of mere entertainment. But polarized light serves many more practical uses. Among these we have already cited the rendering visible of many delicate objects that can otherwise hardly be seen. Further, the ability to classify unknown materials or substances into polarizing and nonpolarizing and thus aid in establishing the identity of an unknown under investigation is often a valuable asset.

But for those who wish to go still farther with it, given a knowledge of crystallography and crystallographic optics it is possible to establish the identity of many chemicals, minerals, and the constituents of composite rocks, and also to differentiate between various fabricated materials on the basis of differences in the amount of birefringence.

To accomplish these results naturally involves very special training. Also, it is imperative that the microscope used be of the type designed for this particular work, the chemical or petrographic model. For casual work polarizers and analyzers can be fitted to any instrument, but those with rotating stages are better fitted for this purpose, as they are more flexible. The polarizing discs (e.g., Polaroid) recently placed on the market are suitable for most types of work but are not adapted for critical tests.

MISCELLANEOUS EQUIPMENT FOR SPECIALIZED PROBLEMS

Numerous problems arise which call for special training, technique, and equipment. Such lines of research as metallography, petrography, micro-chemistry, micro-manipulation and micro-spectrography are hardly within the realm of general microscopy. On the other hand, those specializing in any one of these branches of microscopical science are, as a rule, not interested in the others. For this reason it is not possible to do more than mention some of the equipment available for carrying on these lines of work.

One of the most useful additions to the outfit of any microscopist

is some form of the recently developed *opaque illuminators* for low- and high-power work. The Leitz Ultropak and the Zeiss Epi-W condenser are typical of these developments. These are complete illuminating units, condensers, and objectives, and work satisfactorily even with oil-immersion lenses. Other forms of opaque illumination devices include the Silverman illuminator — a ring form of lamp in a fitting surrounding the objective — and the Bausch and Lomb illuminator, a multiple of small lamps mounted on a ring. With the Zeiss Epi-W model, either oblique illumination around the outside of the objective or central, vertical illumination through the objective, is available. The latter thus serves for visual metallographic work of the conventional type.

For spectrographic work, *spectrographic eyepieces* and *spectrographic condensers* are available. The former provide a spectrum of the light passing through the instrument; the latter superimpose a spectrum illumination on the object. When greater intensity and greater spread of the color bands are desired, mono-chromators are available as illuminators. These can provide a field of any spectrum region desired.

Sometimes examinations must be carried on at elevated temperatures. For this purpose electrically heated *hot stages* are available. These are relatively simple to operate, can be set to maintain a constant temperature, and are provided with a thermometer for noting the temperature.

For those doing work with living organisms — especially water forms, larvae, etc. — so-called “life cells” can be used to advantage. These confine the animal to a small area but allow natural movement or restricted movement through adjustable pressure.

One of the most highly specialized forms of microscopical apparatus is the micro-manipulator, a device in which the movement of micro needles, capillary tubes, hooks, knives, and pincers, can be controlled through the operation of very fine adjusting screws. The operation of this device is so fine and accurate that a single bacterium or blood cell can be isolated and manipulated as desired. The contents of a single blood cell can be withdrawn or a foreign substance injected into it. Those who have problems of this nature should always investigate the possibilities of applying the manipulator to

their work. The Leitz model of micro-manipulator is shown in Figure 58.

It is evident, on the basis of the varied equipment available with which practically every microscopical problem can be solved, that failure to accomplish results, in the last analysis, must be laid to limited ability of the individual and not to his equipment. This being the case, determination to get results and willingness to spend the time necessary to learn how are of prime importance.

Chapter 7

PREPARATION OF MATERIAL FOR MICROSCOPICAL EXAMINATION

The fact that so small a proportion of material to be subjected to microscopical examination is, in its normal state, in suitable shape or condition for study renders the question of its preliminary preparation one of prime importance to the microscopist.

The extreme range in the type of objects and material, both as to size and nature, implies a corresponding diversity in the technique of preparation. Among specialists, working along one line only, the mastery of the various preparation stages soon resolves into a mere routine, the technique of which seems relatively simple. It is when the types of work become diversified that variations in methods and processes become evident.

Nowadays the microscope is employed extensively in the following fields, each of which can be considered a speciality in itself:

- (1) Bacteriology
- (2) Haematology
- (3) Animal histology and pathology
- (4) Plant histology and pathology
- (5) Minute animal and vegetable organisms
(protozoa, the lower metazoa, algae, fungi, myxomycetes, parasitic life, minute aquatic life such as the entomostraca, and numerous others)
- (6) Entomology
- (7) Materials of commerce (fibers, wools, papers, pulp, pigments, artificial products, activated carbons, wood, cement, pulverized materials, ores, chemicals, drugs, etc.)
- (8) Micro-chemistry
- (9) Petrology and mineralogy
- (10) Metallurgy

Certain basic principles of specimen preparation (or, in ordinary terminology, slide making), common to many of these, should be understood by both specialist and general microscopist alike, if proficiency is to be attained. These general and more common preparation methods can be treated in the light of their application, in modified form, to various types of objects; we may leave the more highly specialized subjects for later individual consideration.

Naturally, reduction of mass material of any sort to proper dimensions for study by transmitted light must be accomplished before any examination of it can be made. This applies equally to both permanent and temporary mounts. Indeed, this is so true of almost all but the final stages of slide making that the entire subject can be discussed as though permanent mounts only are involved.

Many instances arise in which merely a casual inspection of some material need be made and there is no reason to prepare permanent mounts. It is a simple matter, however, for anyone possessing an adequate knowledge of how permanent slides are made to adapt only such portions of the technique as are necessary for the production of temporary mounts. Therefore, we give no special consideration to the making of temporary preparations.

Reduction of specimens to suitable size and condition for examination usually involves sectioning, although occasionally pulverizing or isolating of individual constituents by maceration or digestion may be employed.

But when such reduction to size has been accomplished it is commonly found that there is very little natural differentiation of the various components. Furthermore, a section may, in the natural state, appear quite opaque. Also, unless properly preserved, it may rapidly deteriorate. Under these conditions it becomes apparent that mere reduction to size may not suffice; means of differentiating, rendering transparent, and preserving in suitable media are also necessary.

Many organisms and materials are sufficiently minute in themselves to require no further reduction, but here again they may be either excessively opaque or so completely transparent as to be practically invisible in the normal state.

Stated in general terms, the preparation of material, in the form of

permanent slides suitable for microscopical study, involves: first, reducing material, where necessary, to the proper size; second, adequately differentiating the various elements present (usually some form of staining or impregnation); third, rendering the material transparent by use of a medium of suitable refractive index (in the majority of cases known as "clearing"); and finally, preserving the material on a convenient support, in a suitable medium which will preserve it indefinitely.

MOUNTING EQUIPMENT

The first step in slide making is the securing of proper equipment with which to do the work. Some few items are absolutely indispensable; others are largely aids to greater proficiency. The list of necessary items naturally increases as the nature of the work is expanded to include a larger variety of processes.

1. Slides and Cover Glasses

Practically all mounting is done on glass slides and the preparations are covered with thin glass covers. These items therefore naturally are first in the list of essentials.

The standard size slide is three inches long and one inch wide (75 mm. \times 25 mm.), with the edges ground. They are packed in boxes of one-half gross, which can be considered the minimum unit to purchase, although there is a saving in buying in larger quantities.

Other sizes are available for special work — 50 mm. \times 25 mm. (largely used for petrographical work with the universal stage) and 75 mm. \times 37 mm. and 75 mm. \times 50 mm., for larger objects, serial sections, etc. For very large sections special glass plates, of adequate dimensions to accommodate the section, must be prepared. An entire brain section, for instance, requires about a 5" \times 7" plate. When such plates are used, it is desirable to grind the edges to eliminate possible injury to the hands or the microscope. This can be done in a few minutes on a coarse India oilstone, using a mixture of oil and turpentine, or a flat metal or glass plate, using fine carborundum powder (about 200 mesh) and water.

Standard glass slips are available in three thicknesses. The medium thickness, around 1 mm. to 1.25 mm., is preferable for all-around

work. Many condensers will not focus through thick slides, and they are useless for dark field use, while the thin slides are very fragile.

Slides are made from two kinds of glass, pure white and greenish. The former are better looking and transmit shorter wave lengths. Unfortunately, however, they are very easily corroded; when taken out of the box they often have a cloudy surface which is very resistant to ordinary cleaning methods. For this reason the slides with a slightly greenish tint are to be preferred, as they are non-corrodible.

Slides with polished cavities are made for hanging drop bacteria culture work; these are also useful for mounting thick objects requiring a cell, and for studying small aquatic forms (rotifers, etc.) in the living state.

When deeper cells are required they are built up by cementing glass or metal rings to an ordinary slide with a cement which is not attacked by mounting media. Such rings are available from dealers in microscopical material. The cement which works best with non-resinous mounting media is Japan Gold Size. For balsam or other resinous mounting media, some form of nonresinous adhesive must be used.

Cover glasses are made from very thin sheet glass, ranging from .07 mm. to .30 mm. thick. They are graded into four thicknesses as follows:

- No. 0 — .07 to .13 mm.
- No. 1 — .13 to .17 “
- No. 2 — .17 to .25 “
- No. 3 — over .25 “

Unfortunately this grading is very unsatisfactory, for two reasons: the grading is not at all accurate, and the dividing point between No. 1 and No. 2 is placed (purposely?) just where it should not be. For the best all-around use the covers should be within limits of .16 to .19 mm. Consequently, if one uses No. 1 covers, a considerable proportion are too thin, while only a very few out of a half-ounce box of No. 2 covers are suitable. When some means of measuring the thickness (a cover glass gauge or ordinary mirometer caliper) is available, the contents of a box can all be gauged and those of ideal dimensions reserved for critical work. The decision as to whether No. 1 or No. 2 thickness should be purchased will then rest on the

question as to whether most of them are required for use with oil-immersion lenses or for relatively low powers. For the former purpose No. 1 covers are preferable, for the latter the No. 2 are better, as they are more easily handled and not so easily broken.

All thicknesses (except No. 0) are available in various sizes, round or square, and in rectangular forms of larger dimensions up to 2×3 inches.



FIG. 76. Cover Glass Gauge

(Courtesy of Carl Zeiss)

A cover glass gauge, such as that shown in Figure 76, is a useful adjunct to the microscopical laboratory but should not be classed as an essential. If none be available and it is desirable to use only covers of a definite thickness, the latter can be ordered specially, at a premium over regular prices.

2. Implements

A few simple tools or implements, essential for the manipulation of objects in various stages of the mounting process, must be available. Some of these can be improvised as needed, but all are procurable from dealers in inexpensive form. These include

(a) A couple of straight needles (about $1\frac{1}{2}$ " long) mounted in handles of wood, hard rubber, or metal.

(b) A similar needle with about $\frac{1}{2}$ inch of the point bent at an angle of 45° .

(c) A small scalpel or knife with about a half-inch blade and a larger one with a $1\frac{1}{2}$ -inch blade.

(d) A pair of small scissors (1 to $1\frac{1}{2}$ inch blade).

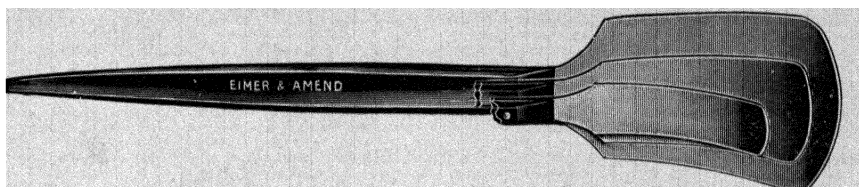

FIG. 77. A Nest of Section Litters

(Courtesy of Eimer and Amend)

(e) Section lifters. A set of three, such as shown in Figure 77, is ideal.

(f) A pair of straight-pointed forceps.

(g) A pair of cover glass forceps such as shown in Figure 78.

(h) A few pipettes with rubber nipples (the medicine dropper type).

(i) A few glass rods with rounded ends (6" long).

(j) A couple of fine sable or camel's-hair brushes (striping brushes).

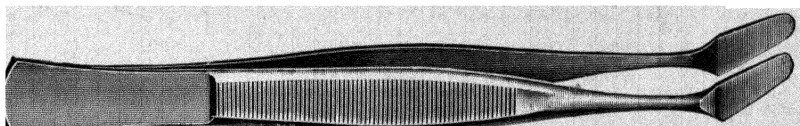

FIG. 78. Cover Glass Forceps

(Courtesy of Eimer and Amend)

When one has worked for some time in the preparation of slides, he will discover other accessory tools that will be useful for various stages of the work. The dealers' catalogues abound with special types of implements, but the list given here will be adequate for most purposes.

3. *Mounting Media, Chemicals, Reagents, etc.*

Probably 95 per cent of all mounting is done in Canada balsam. The beginner will do well to adopt this as standard until he becomes proficient in the various techniques involved with this medium.

Filtered balsam in the natural state is rather unsatisfactory as a mounting medium because of its slowness of drying. For this reason it is usually evaporated to a hard resin state, all the natural volatile constituents being driven off, and then redissolved in a rapidly

evaporating solvent such as xylol, chloroform, or benzol. The former is preferable, but as ordinarily supplied it is too thin for some classes of mounting and is improved by further evaporation. Where possible, it pays to have two grades of balsam on hand, one the thin solution and the other about the consistency of cold molasses.

Other resinous media possessing different refractive indices, such as styrax and gum dammar, are also important for some classes of work but need not be considered an essential part of the beginner's mounting equipment. Hyrax, with a high index (above 1.70), and euparal, with an index below that of balsam, are also valuable for restricted use.

Mounting media of value for very delicate organisms are Venice turpentine and glycerine jelly. With balsam as a standard and these latter for restricted use, the microscopical laboratory is fairly well equipped. Many other media have been suggested and can be used successfully but are not in general favor. Special media for use with ultra-violet illumination will be suggested later, when we discuss this type of work.

A few chemicals, in the nature of solvents, must be on hand for almost every type of mounting. The essential ones are

- Alcohol
- Xylol
- Turpentine
- Crystallized carbolic acid (phenol)

To this list can be added one of the clearing oils such as cedar oil (preferred), clove oil, or oil of bergamot.

The amateur often finds the alcohol situation vexing, although it has not been so serious since the change in the prohibition law. The preferred alcohol is naturally 95% ethyl, with a reserve bottle of absolute ethyl for perfect dehydrating, but the need for a permit in order to purchase it, and its high cost due to the government tax, rule it out. Institutions able to obtain it tax free and laboratories with permits to buy it are not troubled to the same extent.

There is, however, a remedy for the amateur. A high grade of denatured alcohol of high proof is satisfactory for at least 75 per cent of the work requiring alcohol, and most of the other 25 per cent can be done with C.P. acetone-free methyl alcohol. The greatest objec-

tion to this latter is its poisonous nature, but as there is no reason for drinking it and as with care it need not be splashed into the eyes (where even the ethyl would prove uncomfortable), the objection is not serious.

Where only a small amount of xylol is used, it pays to employ the refined only, but when a considerable quantity is needed, a large part of it can be crude xylol (sometimes called solvent naphtha), and the refined may be reserved for special purposes where its use is obviously indicated.

Another solvent of great use to the microscopist, and so included in the foregoing list, is ordinary turpentine. It is superior in some places to xylol, as it will absorb some water, which the latter will not do.

Crystallized carbolic acid we place on the list of essentials because of its great value, both as a clearing agent and in combination with other solvents to aid in dehydrating.

As xylol and turpentine are both clearing agents of the highest type, there is very little need for any others, but it does sometimes happen that an oil such as cedar oil (from the leaves) is preferable. A few ounces of it should be available.

Before the worker has done much mounting, he will discover a growing need for various chemical reagents, but of these, if he were confined to two only, the choice would be hydrochloric acid and sodium hydroxide, with probably ammonium hydroxide, acetic acid, and glycerine coming in as close seconds. Other chemicals are required for the preparation of killing and fixing solutions, preparation of stains, etc., as given in the formulae later on, but they can be purchased as needed.

4. *Glassware*

The glassware requirements of the strictly microscopical laboratory are not extensive so far as mounting work is concerned. However, it will usually be found, after a start is made, that the list of desirable glassware equipment will grow to much larger proportions. At present we shall consider only the bare necessities.

First on the list naturally comes the balsam bottle, for it is required for practically every slide. It is specially designed for the purpose,

with a ground glass cap fitting over the neck, in place of a cork. The cap is high enough to enclose a glass dropping rod with which the balsam is applied to the slide. A conventional form is shown in Figure 79. It is desirable to have two of these, one for thin balsam and the other for thick.

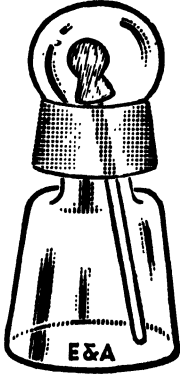

FIG. 79. Balsam Bottle

A supply of watch glasses of various sizes, from $1\frac{1}{2}$ to 3 inches, and a few Petri culture dishes (both deep and shallow form) with their covers, should be available. The latter are not here suggested for their primary function of bacterial culturing but because they are handy for many purposes. They serve as flat watch glasses of larger size; they are especially valuable for keeping material in various solutions when it must be set aside for a day or two; they make good covers for watch glasses; and an entire slide may be placed flat in one when occasion demands.

A few small beakers of 50 to 150 cc., or their equivalent, will be necessary, and also a small glass funnel with filter papers to suit and bottles or flasks tall enough to take the filter stem (unless a filter holder is available).

If much staining of slides in quantity is to be done, suitable staining dishes should be available; the exact type and size will depend on the nature of the work. Paraffin sections also call for a complete series of containers for all the various steps in the process. It is better for the worker not to attempt to obtain the glassware necessary for this work until he becomes familiar with the steps involved and then reckons his requirements.

One of the beginner's earliest discoveries is likely to be an ever growing need for bottles in which to preserve specimens, surplus material, etc. The most useful will be the wide-mouth type in one- and two-ounce sizes, with plenty of the best quality corks to fit. Several dozen of these should be obtained and kept on hand for any need that may arise.

For many processes a chemical thermometer is necessary. One reading a little above 100° C. (212° F.) should be obtained. This range will cover practically all the microscopist's requirements.

5. Miscellaneous Apparatus

The essentials in the way of apparatus for simple mounting are:

- (a) A Bunsen burner, or in the absence of gas, an alcohol lamp.
- (b) A burner stand with two or three different-sized ring supports and a few squares of wire gauze for protection of glassware when heating.
- (c) A warming plate. This can be a copper or iron plate about $\frac{1}{16}$ " thick, large enough to rest on a ring support and extend over some three or four inches.
- (d) A suitable table on which to work.

To these must be added, if sections are to be cut, some form of microtome. For simple sections, a hand microtome such as shown in Figure 80 will suffice, although the sliding type is much better

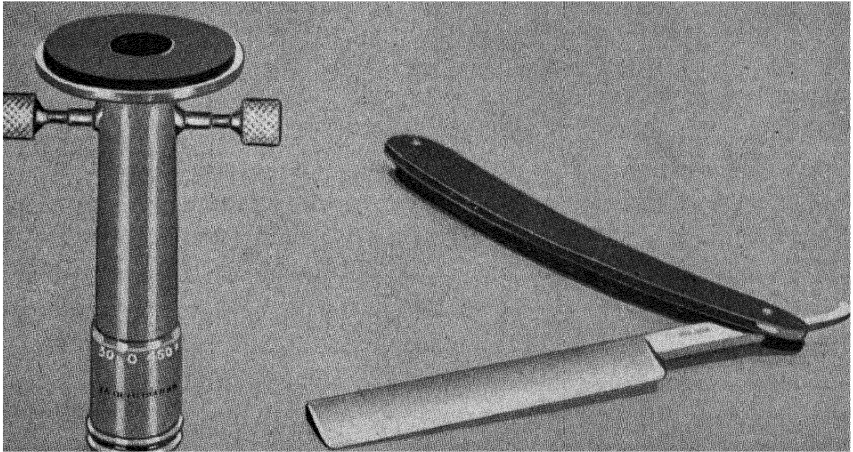

FIG. 80. Hand Microtome and Razor

(Courtesy of Bausch and Lomb Optical Co.)

and is the preferred form for celloidin-embedded sections. For paraffin-embedded sections it is better to choose one of the rotary type. A knife to fit the particular microtome must also be included.

A popular form of the sliding microtome is illustrated in Figure 81 and one of the more elaborate types of rotary microtomes in Figure 82.

Paraffin embedding also calls for some form of oven or heating device where a uniform temperature, accurately controlled

(within $\pm 3^\circ$ F.), can be maintained for several hours. This can be homemade, using carbon filament lamps as heating units, if one be mechanically inclined.

For ringing mounts or making cells a turntable is necessary, although many microscopists find no need for this device, as the practice of ringing slides is not followed to any extent today and very little mounting in cells is done.

6. Stains

The stains which have found favor are extremely numerous and some are of great value in specific instances. The novice is likely to be perplexed as to what are necessary or desirable if given a great number from which to choose. For this reason it is better to confine the list at the start to a very few which can be made to meet nearly every condition. Then, after he has mastered these, he can branch out and experiment with others.

Stains are grouped according to their reactions, in various ways. They may be acid, basic, or neutral in behavior. They may be animal, vegetable, or mineral in origin; examples are carmine, made from the cochineal insect, haematoxylin, produced from the extract of logwood, and the aniline stains, which are coal-tar derivatives. The latter are used today to the exclusion of most others, haematoxylin excepted.

From the practical microscopist's standpoint, the best grouping of stains is on the basis of their reaction to the nucleus and cytoplasm of the cell on the one hand, and on the other, their reaction to cellulose and lignin (or xylem). . It is always a surprise to the uninitiated to find that a section (e.g., of a plant stem) can be placed first in one stain and then in a second, with the result that some structures may be stained a brilliant blue and others a bright red.

A set of stains, sufficient for the beginner to obtain satisfactory results on almost any material, is as follows:

Delafield's haematoxylin
Aqueous eosin
Methylene blue
Carbol-fuchsin
Safranin

The formulae for preparing these, together with a few others, and their specific reactions are given at the end of the chapter. Suggested uses for them will come up in connection with examples given under the technique of mounting.

CLEANING SLIDES AND COVERS

Modern slides and cover glasses reach the consumer in better condition than earlier ones, apparently because they have been subjected to a cleaning process at some stage of production. Nevertheless they must undergo a final cleaning immediately before they are used; the extent of the cleaning will depend upon the way in which they are to be used.

Where there is no attaching of the object to the slide, it usually suffices to wipe them with a cloth moistened with alcohol, cellosolve, or even soapy water until they appear visually clean. When the slides are to be used for smears or for paraffin sections, such simple cleaning does not always guarantee satisfactory results. Often a thin, greasy film remains which must be chemically removed in order to assure the object's adherence to the slide under all stages of preparation.

Various cleaning processes have been suggested for this purpose. The most positive, so far as results are concerned, is soaking in a mixture of potassium bichromate in strong sulphuric acid, followed by rinsing in water and drying with a clean cloth. The corrosiveness of this mixture renders it objectionable and hence a good alternate method is desirable. I myself have used two very simple methods with perfect success. The first of these is partly mechanical in that a cleaning powder containing a fine abrasive (such as Bon Ami or Dutch Cleanser) is employed. Slides are rubbed between the fingers moistened with water and dipped into the cleaner, then washed thoroughly and dried. When slides (or covers) are slightly clouded from incipient corrosion, this is the only method that will render them clear. If this does not work, it is better to throw such slides away, for they are hopeless.

However, cleaning in this manner is tedious and usually unnecessary, as there is a still simpler method. This is to soak the slides (and covers) in a mixture of alcohol and hydrochloric acid (about 80

parts of alcohol to 20 parts of strong acid), and then transfer them to straight alcohol and dry from that with a clean cloth.

The art of wiping cover glasses without breaking them is one that must be learned by experience. The best way is to hold the cover by the edge between the thumb and first or second finger of one hand, then with the cloth over the thumb and second finger of the other hand enclose the cover so that the cloth will wipe both sides at once, rotating the cover with the other hand. Because of the ease of rotation, round covers are more easily cleaned than square. The only advantage the square covers have is that they will enclose a slightly larger area or object for the same dimension cover.

THE TECHNIQUE OF MOUNTING

To follow through the various stages involved in the actual process of slide preparation, because of the radical differences in the *modus operandi*, we can make a preliminary classification of all possible objects which will serve as an indication of the type of treatment they are to receive.

The primary grouping places everything in one of two broad classifications, non-shrinking objects and delicate organic objects. When the reason for this somewhat artificial and apparently arbitrary division is appreciated, it will materially aid in mastering the art of mounting objects for the microscope. Each of these groups must again be divided into those which require sectioning and those which do not; attention must also be paid to whether those in each subdivision require staining or are sufficiently differentiated in the natural state. Having determined on this method of grouping objects for mounting, we consider practical examples under each subdivision, and the reasons why each must be handled according to a more or less definite routine.

1. *Non-shrinking, Non-sectioning Objects*

As a whole, the objects falling into this classification call for the simplest type of mounting technique and so constitute the proper place for a novice to begin his experience. Several different modifications in the mounting processes are involved; the range of objects

included in this grouping is extremely wide but they are all relatively simple.

For simplicity in illustrating the mounting techniques involved, we will subdivide the group as follows:

- (a) Thin, flat, transparent or translucent objects.
- (b) Finely divided materials.
- (c) Smears and objects dried on the slide.
- (d) Whole insects (and parts), normally opaque.

(a) *Thin, Flat, Transparent or Translucent Objects*

Under this heading will come objects such as the wings of insects, or portions cut from them, mica laminations enclosing foreign minerals, dried pressed leaves, paper, thin fabrics, cellophane (for study with polarized light), and similar objects.

In addition to the thin, flat characteristics common to these objects, they possess another which contributes materially to the simplification of the mounting process. This is, they are naturally dry; they have no water to be eliminated before they are put into balsam.

Canada balsam, and other media of a resinous nature, will not mix with water (except in very minute quantity); therefore the complete removal of all water is the first requisite in balsam mounting. It is largely the presence of water which, as will be seen later, is responsible for the grouping into nonshrinking and delicate organic objects.

Objects of the type now under consideration, even if found in water, or thoroughly wetted, can be removed and dried without affecting their nature, so that we can start our mounting of them from the dry state. Many things falling into this group possess an appreciable thickness and so call for thick balsam, as the thin balsam shrinks materially in drying and air bubbles will be drawn in at some time subsequent to the mounting. Suppose we start with some object representative of all the rest, say the wing of a fly. Assuming the previous capture of the victim and the amputation of the member in question by the aid of the fine scissors in the tool kit, we immerse the wing in a little xylol in a watch glass. If any water were present in our specimen it could not be placed directly in xylol, as the latter will not mix with even the faintest trace of water.

Immersion in xylol serves two purposes. First it enables us to use

a fine camel's-hair brush on it to loosen any attached dirt (of which a certain amount can be expected to be present) and then it wets the object with the solvent of the balsam so the latter flows over it easily. With thick balsam air is likely to be entrapped if the balsam be applied without previous wetting. Air so trapped is not easily eliminated. The slide and cover having been previously cleaned, the object is removed from the xylol by means of a section lifter and placed immediately on the center of the glass slide; any excess of xylol is allowed to flow off.

A drop of balsam is now placed directly on the object, a clean cover picked up with the cover glass forceps, warmed a few seconds over the Bunsen burner (or passed rapidly once or twice through a low flame), and placed centrally over the balsam-covered object.

A little experience is necessary for determining the amount of balsam required, but a slight excess is not objectionable. The entire slide is now warmed over the burner until the cover sinks down and the balsam flows freely. A gentle pressure in the center of the cover helps to seat it and to flatten the object. Whatever balsam has flowed out from under the cover is disregarded and the slide is set away for the balsam to harden. It can be examined immediately if desired. Should insufficient balsam have been placed on the object to fill completely the space under the cover, even when pressure is applied, an additional amount can be added at the edge of the cover and the slide may be warmed until the balsam runs in by capillary attraction and the air is driven out. With this procedure, no air bubbles should be entrapped in the mount, but should minute ones be present and resist efforts to dislodge them by careful pressure on the cover, they can be ignored, for they will be absorbed by the balsam within a day or so.

This process represents the basic principle of mounting in balsam and should be mastered at the outset. Any other object falling into this class would be mounted in an identical manner. It might happen, however, that some such object would prove too transparent when so mounted, becoming almost invisible in the balsam. It would then call for staining. For instance, suppose we wish to mount a piece of the fine-textured Japanese lens paper sold for cleaning lenses. It would be too pale in the natural condition. By placing it for a couple of minutes in carbo-fuchin, which is a very powerful stain and

will dye almost anything very deeply, we obtain an intense red coloration. We then wash the piece of paper in clear water until no more color comes off. If it is then too dark (as will probably be the case), we immerse it in 50% alcohol (methyl will suffice) for a few seconds and again wash it. When the color is correct, we remove it from the water and dry it. From this point on, the process is the same as if the original object were the red paper.

As objects of a delicate nature, such as animal or vegetable tissues (most of which require staining), cannot be dried out at any stage without ruining them, one fundamental difference between them and the group under consideration is evident.

(b) Finely Divided Material

A large amount of microscopical work is done on material in a fine state of division, either naturally so, or artificially reduced to this condition. The list would include such objects as diatomaceous earth, cleaned diatoms, radiolaria (polycystina), foraminifera, fungus spores, spicules, chalk, kaolin, sand, tripoli, powdered ores, pigments, activated carbons, starches, etc.

Another type of material which can be included in the finely divided group includes hairs and fibers, although the technique follows closely that of the mounting of flat objects. Hairs and fibers should not be mounted singly, as any variations in size or structure should be evident from the slide. For this reason, as many separate fibers as will conveniently fill a slide without crowding or matting should be cut to fit the cover size. They can then be spread out, moistened with xylol, and covered with balsam and a cover glass. Ordinarily, animal hairs should not be stained, wool being an exception; vegetable fibers, silk, and artificial fibers require staining. Carbol-fuchsin is usually satisfactory, but pure cellulose fibers, such as cotton, may require haematoxylin or a mordanted dye. After staining, the fibers should be washed and dried with blotting paper before mounting.

In mounting powdered material in balsam, three variant processes are possible when it is in an extremely fine state of subdivision. In the first, the particles may be stirred in water containing a little gum arabic or gum tragacanth, then a drop of the water with its dis-

persed particles placed on the slide and allowed to dry. By this method the particles are attached to the glass by the adhesive added to the water and are not disturbed when balsam and a cover are placed over them.

In the second method, the water containing the particles (either with or without the gum) is placed near one end of a slide which has been previously warmed (possibly to about 150° F.). Then with a finger, but no pressure, the drop is smeared across the warm slide and the latter immediately held over a flame to drive off the water as quickly as possible. The thin layer of particles now left on the slide can be covered in the usual manner. The difference between these two methods lies in the fact that in the latter method any inherent tendency of the particles to clump or aggregate is inhibited, whereas they will often aggregate in the former. Certain materials aggregate far more than others.

Both of these methods have the advantage that the particles all lie in one plane. The third method completely eliminates aggregation, but extremely fine particles will not lie on the plane of the glass but will be dispersed throughout the balsam. In this method the particles are moistened with a single drop of xylol in a watch glass, then balsam is added until the material can be thoroughly stirred into it. A drop of the balsam with its contained particles is then placed on the slide and a cover added. Considerable pressure on the warmed slide may be necessary in order to disperse the particles so as to approximate a single layer. Slides mounted in this manner must be kept in a horizontal position for a year at least, as the balsam in the center of the slide is very slow to harden, and if the slides are stored on edge, the particles gradually settle to the lower side. Incidentally, it is preferable that all slides be stored flat.

Ordinarily, objects in this group will not require staining, or rather, many of them will not stain, being inorganic in nature. A few, however, such as the starches and others of an organic nature, need color differentiation for examination in ordinary light. Carbol-fuchsin is an excellent stain for starches. They must be subsequently washed in water and dried. If much staining of finely divided material is to be done, a centrifuge materially hastens the process, as otherwise considerable time is needed for settling before the stain and wash

water can be decanted. After thorough washing, the starches can be dried in a watch glass before mounting.

(c) *Smears and Dried Films, Organic*

Individual animal and vegetable cells of minute size can be dehydrated on the slide so rapidly by the smear method that very little change in their structure occurs. This method therefore offers a way to mount them quickly and in an ideal condition.

Material in this group includes blood, bone marrow, bacteria, organic life in stagnant water, smears from the brain (e.g., in examination for rabies), and other soft, fine-celled organs of the body.

Two modifications of this method are in common use. The first is the smear as universally employed for blood. The smearing itself can be accomplished in two ways, either of which is capable of yielding good results after some practice. In either case, a drop of fresh blood is placed near one end of the slide. In the older method, the edge of another slide is laid over it, still nearer the end, at an angle of 45° to 60° (inclined toward the center) and the drop is quickly pushed across the slide, leaving a thin film smeared over the glass.

The later and more popular method is to use the end of the auxiliary slide rested on the edge of the drop toward the center at an angle inclined away from the center. The blood then fills the angle between the slides by capillary attraction. On moving the end of the smearing slide across that on which the smear is being made, the blood is drawn (instead of pushed) into a smear.

Whichever method is employed, the smear should be dried by gentle heat as rapidly as possible, to avoid any tendency toward coagulation. (This is not so important when a preservative has been added to it to prevent natural changes from taking place.)

Smears from soft tissues are made by drawing them across the slide with sufficient pressure to break down the surface and cause some of the cells to adhere to the glass.

Dried films are produced by placing a drop of water containing the organisms on the slide, spreading it out until quite thin, and then slowly evaporating the water until the slide is thoroughly dry.*

*A valuable modification of this process consists in adding one drop of a 1% solution of osmic acid to the water containing the organisms, after the latter is on the slide. This kills and fixes any organisms present.

Films produced by any of these modifications are practically useless without staining. As most stains are aqueous in nature, if they are placed on the smear the latter will redissolve and leave the slide. To prevent this, we take advantage of the fact that organisms such as those with which we are dealing contain an albuminous substance which can be coagulated and rendered insoluble. Coagulation, or fixing to the slide, can be accomplished either by heating the slide or by immersing it for a few minutes in alcohol (methyl preferred). Alcoholic stains do not require previous fixing, for this is done during the immersion in the stain. When heat is used it must be above the coagulation temperature of albumen but not high enough to affect the organisms. As it is difficult to measure the exact temperature, it should be determined experimentally by each worker for himself. After fixation the slides can be stained, washed in water, and manipulated as desired, without affecting the organisms.

Each different material requires a different stain if ideal results are expected. Carbol-fuchsin is fine for bacteria and stagnant water organisms. The preferred stain for blood is Giemsa (see the formula at the end of this chapter) but a combination of haematoxylin and eosin does very well. Stain in the former ten to fifteen minutes, wash well in ordinary tap water, and transfer to eosin for a few minutes. Rinse and dry. Washing and drying after staining is common to all this type of work, and the application of balsam and cover does not differ from other types of mounting.

(d) *The Mounting of Insects*

The mounting of insects by the pressure method calls for a technique radically different from that for any other organic material. The reason for including it here rather than with the treatment of other delicate organic objects is that the part which is mounted is the outer shell, or exoskeleton, only. This is composed of a substance known as chitin which, after subjection to a preliminary treatment, becomes a hard, flat object which then can be handled and mounted in the manner already described.

Although spiders are not insects, they possess the same chitinous covering and hence are mounted in the same fashion. In many respects spiders are easier to manipulate than insects, as they possess no

wings and the legs are sturdier. For this reason they are good subjects with which to start practicing the art of mounting this class of objects.

The chitin of most insects is very dark, sometimes black and opaque. It must be made lighter and transparent if the preparation is to be studied by transmitted light. Then again, the internal tissues must be eliminated so that the outer shell may be pressed flat; also, the shell itself must be softened so that it will not crack when pressed. All three of these conditions are met by soaking the insect in a solution of sodium hydroxide. About a 10 to 15% solution is satisfactory, but the exact percentage is not important; the weaker solution merely requires a longer time to operate. The strength and length of time will also vary between delicate-bodied insects and heavy, thick chitinous forms. From one to three days is the ideal time. When they have soaked sufficiently long, the legs and body will be soft and flabby; if they are left in too long, the color will be bleached excessively.

When the soaking is complete they are washed well in several changes of water, extending over a few hours; they are then ready for operating upon. The operation consists of placing the insect upon a slide (near one end) and with the needles carefully arranging the legs, wings, head, and body in the preferred position best to illustrate the structure. A second slide is then placed over the other and gentle pressure applied. The internal organs, tissues, etc., having been liquefied by the sodium hydroxide, will all squeeze out, enabling the slides finally to lie quite close together. They are now clipped together (a spring clothespin is fine for the purpose) and immersed in alcohol (denatured is satisfactory).

After a short time in the alcohol, the chitin becomes hardened so that on removal of the slides and immersion of the flattened insect into fresh alcohol in a watch glass, the body will retain the shape in which it was arranged. It is now brushed with a fine camel's-hair brush to get rid of any debris clinging to it, and transferred to fresh alcohol once more. By this time all the water has been removed. It is then placed in turpentine to which has been added crystallized phenol (heated until fluid), then transferred into clear turpentine. After this it is ready for mounting. Transfer it to a clean slide, rearranging parts as they should be, and add balsam and a cover.

Such objects, always among the most striking in a slide collection, offer a fine opportunity to study the external parts of insects. Plate XVI shows a large *Lycosa* spider mounted in this manner and Plate XVII the proboscis of a housefly. It is obvious that if an entire insect is not desired, any portion of the body can be treated in the same manner.

In addition to the pressure method, small insects, larvae, etc., which are not too dark in color can be prepared without pressure, with the preservation of all the internal structures. The method for doing this is substantially that described later for mounting small delicate organisms entire.

2. *Non-shrinking Materials Requiring Sectioning*

Items included under this classification, though not extensive in number, nevertheless constitute commercially important materials. The list is circumscribed on the one hand by objects which are so delicate or friable as to require embedding in some medium which will serve as a support to retain the parts in their proper relation to each other. At the other extreme lie those objects too hard or brittle to be sectioned with a knife, requiring grinding to reduce them to the desired thickness. Within this group are included most woods, vegetable ivory and genuine ivory, shells and seeds of various nuts, the sclerotium of various fungi, non-brittle synthetic resins and other artificial products, and the like. The majority of these cannot be cut on an ordinary microtome and are sure to ruin a fine microtome knife. Very powerful, heavy, automatic microtomes using thick, chisel-edged knives are available. They are very expensive, but if a considerable amount of work is to be done, they will be found to pay for themselves.

The best way of cutting occasional sections of these materials is with a hand microtome, using a chisel-edged knife or a specially made thick-bladed one of very hard steel.* If the piece of material is large enough, it can be held in a vise and sections cut with a well-sharpened hand plane.

It is better not to try to get large sections; the smallest which will show the desired structure in a satisfactory manner will be found

*A very satisfactory blade can be ground from a heavy file.

better than larger, uneven sections. Nor is it always possible to cut to a predetermined thickness; sometimes 15 microns will be found possible, at other times a material may require 50 microns.

Often the material must be sectioned in a particular direction or more than one. Wood requires sections in three directions properly to show all structures — transverse (i.e., across the grain), radial (on a line from the center to the bark), and tangential (parallel to the bark).

In the cutting of wood and some other substances, it helps materially to soak it previously in water or even boil it for a short time, as the wet fibers are much softer and easier to cut. After cutting the sections they can be allowed to dry out, or, in case they are to be stained, they can be placed in water or alcohol.

Of the materials in this group, most of those which will stain at all respond to carbol-fuchsin or safranin. Some will not stain.

Once the sections have been obtained, the method of mounting follows that of any thin flat object, as already described.

3. *Delicate Organic Objects*

We now come to an entirely different type of objects, those constituting the great mass of living organisms composed of delicate tissues, built up of cells of which we desire to see the most minute detail, just as in the living condition.

When the cells of such tissues die, post-mortem changes occur sometimes almost instantly, altering the nature of the cells, which if studied in this condition would give a false picture of their real nature. Yet on the other hand, it is obvious that the living cells cannot be stained and mounted.

It is to meet this situation that biologists have developed a special technique for the handling of living organisms and tissues. The process starts with the living organisms and involves as the first step immersion in some solution which will kill and fix the cells in their natural state before changes can take place.

(a) *Killing, Fixing, and Preserving*

A large number of solutions have been developed for killing and fixing. Some of these are for very specific purposes, as it has been found that what works well in one instance is useless in others. Some

chemicals are good killing agents and poor fixing agents, others just the reverse, while some few are both in one.

The most common and useful killing and fixing agents are chromic acid and its salts, acetic acid, osmic acid (osmium tetroxide), formalin, and alcohol.

One great factor in determining the value of a fixing agent is that osmotic pressure is set up between the cell contents and any external fluid, which will cause the cell to expand or contract, depending upon whether the external or internal pressure is greater. Therefore, if two fixing agents with opposite tendencies can be mixed in the proper proportion to balance the surface tension of the cell, there will be no change while the fixing is being done. For instance, for general botanical work, a mixture of chromic and acetic acids is very good. The formula and more specific directions for using it are given at the end of the chapter.

Some fixing solutions are ideal for quick and perfect fixation when they can reach the cells but have very little penetration, so that they are useful only with small pieces of tissue. An example of this is the chrom-acetic-osmic solution of Fleming, one of the best known for fixation of cells in process of division.

Fixation is followed in every instance by preservation, that is, getting the tissues or organisms into some solution where no further change can take place, and in which, if necessary, they can remain indefinitely.

A few fixing agents — formalin, for example — are also good preserving agents, especially if somewhat diluted, but others continue to harden the tissues until they become brittle and useless. For this reason they cannot be allowed to act too long.

The best all-around preserving agent is 70% alcohol; the next best is 5% formalin.

The delicacy of these tissues, even after fixation with its accompanying hardening, still renders it necessary to change from one solution to another by gradual steps. If taken from water and immersed directly in alcohol, they will be shrunk and distorted by the osmotic pressures set up. For the very best results the change must be accomplished by small steps: from water to 5% alcohol, then 10%, 15%, 20%, 30%, 50%, 70%, and so on.

Although it is possible to do some staining while the tissues are in the mass, this method is not widely used. Staining is about the last operation before they are covered with balsam. After they are fixed and placed in the preserving solution they can stand until wanted.

(b) *Embedding Methods*

Some few structures — the harder stems of plants, roots, etc. — can be cut without embedding, but in general all delicate tissues are preferably embedded for sectioning.

Two embedding methods have been developed and are in general use. These are known as the celloidin method and the paraffin method. Each has its particular points of advantage, although many objects can be mounted satisfactorily by either.

Where there is a great difference in the hardness of different portions of a tissue, the celloidin method is preferable, as it offers a much firmer support against which to cut. When serial sections are desired, the paraffin method is the one to use. Much thinner sections can be cut with the paraffin method, even down to two or three microns, although from five to ten is the average thickness required. It is difficult to cut celloidin sections thinner than about 15 microns; to cut to 20 or 25 is far easier.

The first step in both methods is identical: the tissues must be gradually run up from the preserving fluid to absolute alcohol. In other words, there must be no water left in them and it must be replaced so gradually that no shrinkage of the tissues or cytoplasm of the cells will occur. From this point on, the technique of the two processes is different.

Following the celloidin method as the simpler, first, we must get the tissues from pure absolute alcohol over into a mixture of 50% alcohol and 50% ether. In this step it is well to go first into 75% alcohol and 25% ether, leaving the tissues there for half an hour or so before transferring them to the 50-50 mixture. The reason for the alcohol-ether mixture is that this is the solvent for the celloidin.

Celloidin, also sold under trade names, such as Parlodion, is a pure form of collodion. It comes in shredded form preserved in water. The shredded material is thoroughly dried upon removal from the water and a solution is made by dissolving it in sufficient

alcohol-ether solution so that it will have the consistency of a thin syrup. Some workers prefer to use as many as four different solutions, each a little thicker than the previous one, the last being about as thick as cold honey. The specimens are transferred from the alcohol-ether mixture into the thin solution and successively into the others. They are left in each as long as a day, if possible. A simpler plan is to place them in the thin solution and then allow the solvent to evaporate slowly until at the end of three or four days the consistency is that of the heaviest solution. It should be such that when a specimen is removed from it with a pair of forceps, it will be coated all over with at least one-eighth inch of celloidin.

Tissues are mounted on a wood or fiber block for sectioning, thus: Wet one side of a block (of suitable size to hold the tissue and mount in the microtome) with alcohol-ether and immediately dip it in the celloidin, some of which will adhere. Then remove the specimen tissue with its adhering celloidin and place it on the coated block. Keep the coating over the object until the surface has hardened with a thin membrane over it; this will occur within a few minutes. Then drop block and all into 85% alcohol.* The specimen must be left in this solution until it is completely hardened, i.e., for several hours. It is then ready for cutting into sections.

In the paraffin embedding method, the same underlying principles apply, but as the solvent for the paraffin is xylol (others can be used but this is the simplest for a beginner), it is apparent that the transfer from absolute alcohol must be made to xylol instead of alcohol-ether. Here again the transfer must be made gradually, at least three steps being made between the pure alcohol and the final pure xylol — say, 25% xylol, 50%, and 75%, then 100 per cent. It is preferable to leave the specimens at least one-half hour in each solution.

When the tissues have reached the pure xylol, we start adding small pieces of a hard paraffin to it until saturation has been reached. Pure paraffin† is warmed in the oven until it has just passed its melting

*This is one case where care must be taken in using methyl alcohol. It is better to use denatured if pure ethyl is not available. Denatured can be diluted to 85% without clouding.

†The best results will usually be obtained with a paraffin possessing the highest melting point obtainable commercially.

temperature a few degrees — i.e., if it is a 50°–55° C. paraffin, the temperature should not be allowed to go above 57° to 58°. The tissues are removed from the solvent with its dissolved paraffin and placed in the melted paraffin, which must be kept at temperature for from one to four hours, depending upon the size of the pieces and their nature. Better results are assured by transferring the specimens to fresh paraffin at least twice during the embedding, as this helps get rid of the xylol originally present in the tissues.

The last step in the embedding process is casting the tissues in a mold of the proper size to accommodate them. For this purpose metalells are the best, but many workers fold up a small paper box into which the melted paraffin can be poured and in which the specimen may be placed and oriented. The bottom of the mold will naturally be the top of the paraffin block from which sections are cut, as the tissues sink, and they must be arranged accordingly before the paraffin sets. After the paraffin has solidified so no liquid surface is present, it should be cooled as rapidly as possible by immersion in cold (or ice) water.

After it is cold, the mold is removed, the block is attached to a piece of wood or fiber by means of melted paraffin, the excess paraffin is removed, and the sides are dressed parallel. It is then ready for sectioning.

(c) Sectioning

Freehand sectioning, whether of embedded or non-embedded objects, is possible but far from ideal. With practice sections suitable for study purposes can be produced but they will invariably be tapered and excessively thick in some places.

If no microtome is available, instead of relying on the ability of the hand to guide the knife, it is far better to construct a V-shaped wooden trough properly supported on a base, in which the material can be held while sectioning. At the end where the cutting is to be done there may be mounted a piece of flat brass with a V filed in it to match the V in the wooden trough. The brass plate serves to guide the knife, and each time a cut is made the object can be pushed forward a distance corresponding to the desired section thickness. The object is held firmly in the trough with one hand while it is cut

with the other. If serious section work is contemplated, a microtome of some sort should be obtained.

Although we are principally concerned with the sectioning of embedded objects, it is worth noting that some tissues, especially of a botanical nature, such as the stems and roots of plants, can often be cut without interstitial embedding. It must not be expected that such cutting will yield as good results as when the tissues are properly

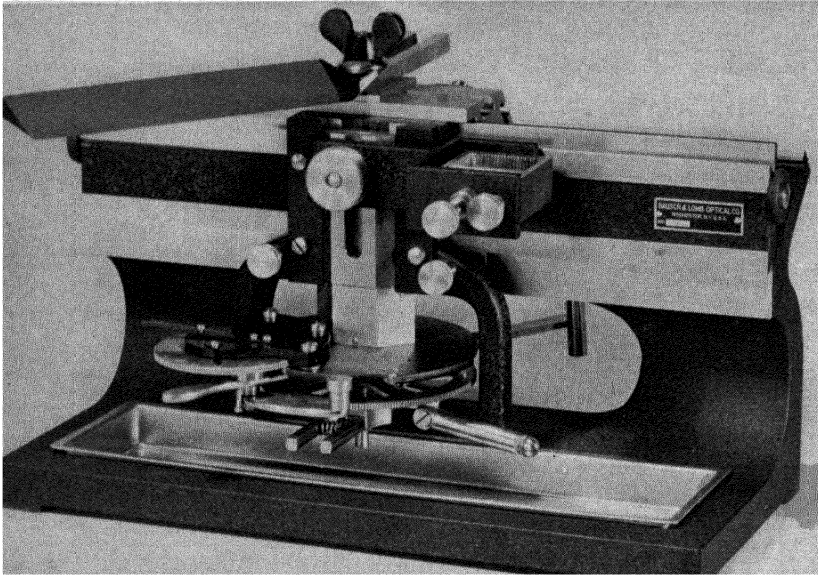

FIG. 81. Automatic Sliding Microtome

(Courtesy of Bausch and Lomb Optical Co.)

embedded. In these cases it is desirable to protect the cortex from being torn or pulling away from the woody parts, through the delicate cambium layer. This can be prevented to some extent by wrapping paper or other support around the stem and cutting both together. Here the paper serves as an exterior embedding material. Another method is to pour melted paraffin around the object without any attempt to make it enter the tissues interstitially. Endogenous stems with a hard external layer do not require such support.

Celloidin and paraffin embedded materials are sectioned quite differently. With the former the knife is set at a sharp angle, to make

a sliding or sawing cut. Both the block and the knife must be kept wet with 85% alcohol. Each section as cut is removed from the knife and placed immediately in the alcohol, where it remains until staining.

Cutting must be done with a steady, even motion, and not too rapidly. The knife must be kept sharp.

Paraffin sections are cut with the knife edge at 90° to the direction of motion and the sides of the block must be parallel with the edge



FIG. 82. Rotary Microtome

(Courtesy of Spencer Optical Co.)

of the knife. The rotary type microtome is preferable for this class of work because the sections are not cut singly as with celloidin; each section as cut remains on the knife. The next cut causes the front of the succeeding section to hit against the back of the previous one with sufficient force to stick them together. Both are then pushed along as if the first were an integral part of the one being cut. Continued cutting in this manner produces a ribbon of sections in which each is in the proper order with reference to the adjacent sections. These are known as serial sections.

There are many things in the technique of serial section cutting which must be learned by experience. Only in a general way can they be pointed out, as a guide to the novice.

Some of the factors which are variable and cause trouble, or at least necessitate modification of the technique are the hardness of the paraffin, the temperature of the room, the block, and the knife, the desired thickness of section, and the slant of the knife.

Sometimes the electrostatic conditions of the atmosphere is such that the ribbons cling to the knife or jump to the hand or anything near them. Under such circumstances it is better to defer cutting until a more propitious occasion.

The most common trouble is a tendency for the sections to collapse into a wavy or folded condition from which they cannot be straightened out. This can always be traced to excessive softness of the paraffin in relation to the cutting temperatures involved and the thickness being cut. Any or all of the following steps may provide the remedy:

- (a) Chill the block in ice water.
- (b) Chill the knife.
- (c) Cut in a cooler room.
- (d) Cut thicker sections.
- (e) Change the angle of the knife.
- (f) In the future use a harder grade of paraffin for embedding.

The other extreme will be that the sections, though cutting nicely and lying flat, will not adhere to each other to produce a continuous ribbon. Usually cutting thinner sections will correct this trouble, but if not, cutting in a warmer room or changing the angle of the knife will suffice.

It is seldom that sections will cut without some slight waviness present, and also a little compression of the block width — that is, the measurement across a section will be less than the block dimension — but no attention need be paid to this as later treatment remedies it.

If the ribbons do not come off straight but are curved, it is because the sides of the block are not parallel.

For easy identification of the juncture between sections, when the tissue is small and inconspicuous, one end of the block can be cut off at an angle so that the side of the ribbon, instead of being straight, presents a saw-toothed appearance, a notch for every section.

If the sections are badly scored or even cut completely through in the direction of the knife travel, the fault can be traced to a nick in the knife or occasionally to a minute bit of paraffin adhering on the edge.

The knife must be even more than razor-sharp. Considerable experience is necessary in order to hone and strop a knife to the requisite degree of sharpness.

For honing, three types of stones are desirable: a No. 600 carborundum microtome hone, a yellow Belgium, and a blue Belgium hone. The first is for rapid cutting; the second, used with soapsuds as a lubricant, gives a semi-finish; and the third, which is provided with a rubbing stone of similar composition (for producing a lather with water), gives a very fine edge, which hardly requires any stropping. The manufacturers furnish spring backs which support the knives, during honing, at a little sharper angle and hasten the operation. When the knives are sharp enough to cut the dry hairs on the back of the hand near the tips without sliding over them, they are honed sufficiently fine to strop. This operation should not be prolonged; a few strokes only should suffice.

(d) Staining and Mounting

It is after the cutting of the sections that the processes of mounting by the celloidin and paraffin methods part company in a radical manner. Up to this point there has been a similarity in the technique, differing only in the embedding materials, solvents, temperatures, etc., and in the final form in which we have our sections.

At this stage, celloidin sections do not differ materially from other thin, flat objects requiring staining before mounting. Nor does the staining offer any serious difficulties; in a few minor details only are there special conditions to be met. The first of these is that the objects must not be allowed to become dry at any stage of the process, or they will be ruined.

In the staining of celloidin sections, we find that celloidin itself stains to some extent. There are several ways to overcome the staining of the celloidin. If it is not intense, it can be ignored, as it is a transparent color after clearing and does not interfere with the more deeply stained tissues. Tissues stained in more dilute solutions for

a longer time will be found to be sufficiently stained while the celloidin is still rather pale. The more common method is to overstain and then slowly decolorize. With haematoxylin, which will naturally be frequently employed with celloidin sections, this plan works beautifully and the celloidin can be almost completely decolorized. This is accomplished by transferring the sections after staining, washing, and placing (by gradual steps) into 85% alcohol, and then into alcohol which has been *very slightly* acidified with hydrochloric acid. Only one or two drops of acid to 10 or 15 cc. of alcohol are required. The sections must be moved around in the solution and watched to prevent too much decolorizing of the tissues. When this bath is completed, they should be transferred to 85% alcohol to which a drop of ammonia has been added, and then into fresh 85% alcohol.

If it is desired to counterstain with a contrasting color — eosin, for example — the sections must be returned to water unless an alcoholic stain be used. Most of the counterstains will be sufficiently washed out of the celloidin by plain alcohol. As a matter of fact, the alcohol tends to decolorize the tissues as well, so their time in it may sometimes best be kept to a minimum.

A method of overcoming the staining of the celloidin which can be used with sections when the latter are such as to require the celloidin embedding only for cutting purposes and are firm enough to resist shrinking and disintegration when it is removed, is to dissolve it completely from the section with alcohol and ether, or by adding acetone to 85% alcohol. Beautiful results can sometimes be obtained in this way.

Where this cannot be done, after the staining is complete and the sections are in 85% alcohol, they must be cleared before going into balsam. If 95% ethyl alcohol be available, they can be passed into this, then into xylol to which a little crystallized phenol has been added, and then to pure xylol. They can be mounted from this in balsam in the regular manner.

A very good substitute for this clearing process is to go from the 85% alcohol into a clearing oil of the following composition:

Oil of cedar	1 part
Oil of bergamot	1 part
Crystallized phenol	1 part

The sections can go from this directly into balsam but should be well drained of the clearing oil, as the presence of the latter slows up the drying of the balsam.

The technique of mounting paraffin ribbon sections, once mastered, is quite simple — it is that most used in general histological (both animal and plant) and pathological work — although the description of it may appear complicated.

Any number of sections, from a single one to as many as will fill all the available space, can be mounted on a slide. If the object be small, it is better to mount several rather than just one. The first step is to cut the desired number of sections from the ribbon. These may be wavy or wrinkled, and must be flattened and expanded. An additional step may be saved by doing this on the slide on which they are to be mounted. For such a purpose the slide should have been prepared in advance. First slides must be very thoroughly cleaned and then they are given a coating of albumen fixative (see the formula at close of chapter). To do this, place a small drop of the fixative in the center of the slide and smear it around thoroughly with a clean finger tip, covering all the area to be occupied by the sections. Finally, wipe it off with the fleshy part of the palm at the base of the thumb until only a thin film remains. If too much is left on, it will stain and cause the slide to appear messy. The purpose of the fixative is to provide a thin coating of albumen which will cement the sections to the slide for passage through the remaining steps.

The coated slide is laid flat and flooded with clean (preferably distilled) water from a pipette; care must be taken that not enough is put on to run over the edges. Upon this the cut piece of sections from the ribbon is placed and the slide is put on the warming plate over the burner. As the water on the slide warms, the section expands and flattens. As soon as this occurs (the paraffin must not be allowed to melt) the slide is removed from the warming plate and allowed to cool. Then the water is drained from the slide and the section arranged as desired. It must then be allowed to dry thoroughly. If in the air this will require several hours, but if an oven be available, it will dry in an hour at a temperature a few degrees below the melting point of the paraffin used. By this time the sections are cemented to the slide sufficiently to hold them in place in the early

stages of the paraffin removal (the immersion in the xylol and alcohol completing it) through coagulation of the albumen.

The paraffin must now be removed and the slide with the adhering sections placed in water preparatory to staining. With thin sections it is no longer necessary to change from one solution to another by extremely gradual steps, but on the other hand, abrupt changes must be avoided. The following give good results under most conditions, but for special nuclear and cytoplasmic studies, the steps may need to be more gradual.

- (1) Immerse in xylol – 5 minutes (to dissolve and remove paraffin)
- (2) Place in fresh xylol – 1 minute (to wash out paraffin-contaminated xylol)
- (3) Into 50–50 xylol and alcohol – 2 minutes
- (4) Into pure alcohol (denatured can be used) – 1 minute. (*Note:* Whenever denatured alcohol is used, it must not be the last step before placing in water. Always use another step of pure ethyl or methyl between the denatured and water.)
- (5) Pure ethyl or methyl – 1 minute
- (6) 50–50 alcohol and water – 1 minute
- (7) Pure water

The slide is now ready for staining with an aqueous stain. If an alcohol stain is to be used, go from step 5 into the stain.

Staining of sections on the slide does not differ from other staining of sections except that the entire slide must be immersed in the stain. For this reason special staining dishes such as the Stender pattern are desirable. In the absence of these, the slides can be laid flat in a petri dish.

After the staining and counterstaining (if any) is complete and the slides have been washed, we must now reverse the steps to get them back into xylol. The following will usually suffice, a couple of minutes in each being ample.

- (1) From water into 50–50 water and alcohol
- (2) Into pure alcohol
- (3) Into second alcohol (for complete removal of water)
- (4) Then in 50–50 alcohol and xylol
- (5) Into xylol with a little crystallized phenol in it
- (6) Into pure xylol
- (7) Remove from the xylol, drain, and add balsam and a cover

4. *Small, Delicate Organisms Mounted Whole*

There is a large group of organisms, both animal and plant, that are especially adapted to mounting whole as transparent objects, not pressed, in balsam.

The list includes small larvae and pupae of insects, delicate adult insects, the water fleas (copepods, entomostraca, and ostracoda), planarians and other flat and round worms, hydra and various hydroids, bryozoa, mites and ticks, lice, and the like. In the botanical field many of the algae can be so mounted.

Where the forms are aquatic and no special attention need be paid to the position the various parts must have in relation to each other, the simplest plan is to pour into the water containing the organisms enough formalin to make a 10% solution with the water. If they are to be preserved indefinitely, it is desirable to reduce the formalin content to 5-7% after a day or so by the addition of more water, as the stronger percentage tends to harden them excessively after a time.

When brought into contact with an irritating killing agent many animals contract the body or withdraw parts which should be in an expanded condition. Examples of this are the hydra and hydroids, planarians, rotifers, etc. In such cases it is necessary to narcotize them slowly until they lose the power of muscular control before killing. For most purposes a 1% solution of chlorotone in water works nicely, but some delicate rotifers resent even this agent. A still milder chemical is hydrochlorate of cocaine in 1% solution, but this is difficult to procure because of the narcotic laws. Whatever is used must be added slowly to the water in which the organisms are concentrated (e.g., in a watch glass), allowing them time to assume an expanded condition before adding more. When they are fully narcotized, the killing and fixing agent can be flooded on them suddenly.

Many of these organisms do not require staining, as there is sufficient pigment or differentiation in the various tissues to make them evident. Others, like the water fleas, are quite transparent and are much better stained. For this purpose several of the aniline stains will be satisfactory — fuchsin, gentian violet, dahlia, eosin, methylene blue, and safranin can be tried.

The simplest method of clearing these objects is to transfer them

directly from water into strong carbolic acid. The acid is made by adding just sufficient water and glycerine (equal parts) to the crystallized phenol to allow it to remain liquid at ordinary temperatures. In the carbolic acid the organisms become beautifully transparent, although some stains are extracted. In this way differentiation of structures can sometimes be secured if two contrasting stains have been used.

The tissues, as a rule, do not shrink in the carbolic acid; the bodies remain plump and natural. The serious difficulty is in getting them from the carbolic into the balsam. Generally, adding a mixture of cedar oil and bergamot oil to the carbolic, a few drops at a time, letting it stand until thoroughly diffused, ultimately withdrawing a portion of the carbolic mixture and adding cedar oil until the final fluid is practically pure cedar oil, will give perfect results. With balsam of about the same consistency as the cedar oil, the specimens can be removed from the latter, placed on a slide, and covered with balsam and a cover glass in the usual manner.

Of course, the more delicate the organisms, the more care must be used to prevent shrinkage and collapse of tissues. Some will stand much in the way of sudden change, while on the other hand some very delicate tissues and cells are encountered which must be mounted by the Venice turpentine method or in a fluid, as described later.

5. *Finishing the Slide*

With practice and experience, it is possible to add just the proper amount of balsam to fill the space under the cover when the latter is down flat, as it should be, without allowing any to run out around the sides of the cover. When such a slide is dry, i.e., after a week or two, it is ready for labeling.

But with many types of mounting such a condition is not so easily attained; in spite of care, the balsam may be added in excess and form a good-sized ring around the outside of the cover. Such slides require finishing if they are to appear presentable. The procedure is to allow the balsam to become hard enough to chip off with the point of a knife. (Care must be exercised not to crack the cover.) After it is all scraped off, a cloth moistened with denatured alcohol is used to clean the slide. Alcohol is preferable to xylol for this purpose, as it

does not soften the balsam under the cover to the same extent. After cleaning, the slides are ready for labeling.

Standard labels approximately an inch square are available; there are also other sizes, ovals, etc. The former are preferable when space permits. Some workers prefer to place a label on each end, one for the name of the object, the other to carry special data regarding it. These data may be anything of interest to the individual worker and possibly of importance at some later date. They include such items as method of mounting, stains employed, thickness of section, date prepared, cover-glass thickness, position of special points of interest on the object, locality where the object was found, and many others.

If a slide collection is to be of scientific value, an attempt should be made to identify species or particular tissues in so far as possible. Although it may suffice for a beginner, interested only in having a series of objects in his collection, to mount a mosquito and label it merely "Female Mosquito," it is a far greater incentive for him to add to his collection when the label reads, "Mosquito, *Aedes cantator*, female." The desire to compare it with the male of the same species and with a female *Culex pipiens* or an *Anopheles*, is almost invariably a psychological result of such method of labeling.

Slides may be stored in cabinets, properly classified, or in boxes of one hundred or smaller boxes of twenty-five. The cabinets usually provide for their lying flat, which is far better than standing on edge. When the boxes of one hundred or twenty-five are used, they should be stored upright so that the slides will lie flat.

Where a definite line of research is being followed, it pays to keep a card index of each slide for detailed information, using plenty of cross-index cards for easy reference.

6. *Special Preparation and Mounting Methods*

In addition to the general methods of mounting already discussed, there are several others with which a microscopist should be familiar. Some of these have been largely discarded as relics of the early days of microscopy; others are of great importance in specific lines of work.

(a) *Dry Mounting*

This was one of the popular methods of the past generation. It was largely used for opaque objects to be viewed by reflected light.

Only in rare cases, such as the mounting of a thin section of bone, or diatoms, has it been employed for transparent objects.

Many microscopical objects are suitable for this type of mounting and it should be in more common use. The list would include minute fungi, aecial, uredospore, and telospore stages on leaves and stems, plant hairs on leaves, pollen, seeds, radiolaria, foraminifera, butterfly and moth wings, minute crystals, etc.

It is necessary to have an opaque background on which the specimen can be mounted. Sometimes it is possible to purchase cells, made from opaque molded plastics, for this purpose; where this is not possible, the cell must be homemade. When a turntable is available, a quick-drying black japan or black cellulose nitrate lacquer can be applied as a disc of the desired diameter in the center of the slide; then, after the flat disc is thoroughly dry, an outer ring can be applied to build up a cell to the required depth. Other methods, such as a disc of black paper glued to the slide with a cardboard ring attached to form the cell, will suggest themselves to the practical worker.

The only important point to remember in making dry mounts is that they must be thoroughly *dry*. They should be attached to the center of the cell with glue, shellac, lacquer, or other adhesive. After superficial drying, it is desirable to place them in a warm oven (the temperature must be kept under 100° C.) until completely dehydrated.

After selecting a cover of the proper size to fit the cell ring, the latter should have a minute quantity of gold size applied to it. When the gold size has dried until it is just slightly tacky, the cover (properly cleaned) is pressed down upon it and the mount is complete and ready to label, although the gold size requires a day or so to harden completely.

One objection to such dry mounts is that even with careful drying before applying the cover, a little clouding of the inside of the cover will often occur. If they are still clear at the end of a year, however, the chances are that they will remain so.

Dry mounting of diatoms does not require a cell, as these are always viewed as transparent objects. The only reason for dry mounting for these is the low refractive index of air, which causes the frus-

tules to stand out much more brilliantly than when in a medium of higher refractive index.

The preferred practice is to place the cleaned diatoms in water to which a minute quantity of gum arabic has been added. A drop of water containing the diatoms is placed on a clean cover and allowed to dry. The gum arabic is just ample to cause the diatoms to adhere to the cover.

A thin ring of gold size of the proper diameter to fit the cover is run on a slide by means of a turntable and the cover is laid on it, diatoms downward. Other minute objects can be prepared in the same manner if desired.

Box Mounts

A different type of dry mounting is especially adapted to microscopic mineral specimens, myxomycetes, and other objects where the depth is considerable, possibly as much as a quarter of an inch. This is known as box mounting.

Small boxes one inch square by one-half inch high can be procured from box manufacturers or from some dealers in microscopical supplies. These must be blackened inside. India ink is suitable for this purpose. A small piece of cork, also blackened, is glued to the bottom of the box, usually in the center, to serve as a pedestal upon which the specimen may be mounted. The latter is in turn glued to the top of the cork, the height of which is such as to cause the highest part of the specimen to be just below the top edge of the box. The cover of the box protects and preserves the specimen when stored, but is removed for examination of it. The labeling should be done on both the cover and the bottom of the box.

A larger box holding one dozen of the individual boxes is used for storing them. Specimens mounted in this manner for viewing with the low-power binocular microscope are always popular and pleasing.

(b) Fluid Mounts

Mounting in fluid is confined to objects of a delicate nature extremely sensitive to even minute changes in the pressure tensions

encountered in the various steps of resinous mounting or which require a deep cell if they are to be mounted without pressure.

Refinement of technique and the development of new processes have largely superseded fluid mounting, as the latter has two inherent drawbacks very difficult to overcome. These are: the fluid tends to leak out after a time, because of deterioration of the sealing medium; or, when this does not happen, frequently vaporization occurs and in some mysterious manner bubbles of gas appear in the fluid. Nevertheless, in spite of these objectionable features, a knowledge of the technique of fluid mounting is desirable.

In a few instances more natural mounts can be prepared in this way than by any other technique. Especially is this true of the rotifers, which can be made to look exceedingly lifelike without staining.

The fluid employed can be clear water with just sufficient preservative in it to prevent bacterial attack on the specimen. The preservative can be formalin, carbolic acid, bichloride of mercury, or the like.

Where the natural differentiation of the specimen will stand a higher refractive index medium, pure glycerine, glycerine jelly, lactophenol, Farrant's medium, or some similar mountant can be used. Each of these requires a slight difference in the details of mounting, but the general principles are similar in all.

A cell must be prepared by cementing a ring of glass or metal to the slide, using some adhesive or cement immune to the solvent effect of the mounting medium. Gold size and bakelite varnish are very good for most classes of work. When the objects are extremely minute, such as the rotifers, the separate ring is not required; a cell of ample depth can be made with the sealing cement alone. Or if a setting or hardening medium such as glycerine jelly is chosen, it requires no cell or ring for shallow objects, for the mounting is done when the medium is fluid (e.g., glycerine jelly is warmed to liquefy) and hardening provides a sufficiently firm slide to stand sealing with a final ring of cement. Except for the use of the fluid instead of air, the technique does not differ from that of dry mounting. Use of a fresh layer of gold size before placing the fluid and object in the cell provides a seal for the cover when pressed down over it. Surplus mounting medium will be pressed out and will not interfere with

the cover's sticking to the gold size. All excess fluid must be carefully wiped off and an additional ring of gold size added over the edge of the cover. When this is dry, it pays to add a couple of additional layers of gold size so as to obtain a fairly thick seal. If desired, the final layer can be a black japan or lacquer.

Such slides, properly made, will keep for many years, often indefinitely.

(c) *Mounting in Venice Turpentine*

Venice turpentine mounting has come into favor of recent years and is a great advance over fluid mounting for many classes of delicate objects. The beauty of the process is that, when finally dry, Venice turpentine is a hard, resinous mountant equal to balsam. It owes its success to the fact that Venice turpentine, a resin obtained from the European larch, is soluble in alcohol and therefore specimens do not require passing through the xylol series, where the tendency to shrinkage and distortion is considerable.

Fine algae, — spiragya, zygnema, etc., — the mycellium of fungi, and delicate unicellular organisms can be mounted in a perfectly natural condition, stained or unstained.

A brief outline of the process follows:

After fixing and staining and such initial preparation as the objects are to receive in an aqueous medium, they are transferred to a 10% glycerine solution in water. This is preferably placed in a petri dish and in a desiccator.

In a couple of days the water will all be extracted from the solution and the objects will be in pure glycerine.

They can now be flooded with 95% alcohol without danger of shrinkage, washed in the alcohol to get rid of the glycerine, and finally rinsed in absolute alcohol to reduce the quantity of retained water to a minimum. This last alcohol is poured off and they are covered with a 10% solution of Venice turpentine in absolute alcohol. The quantity of turpentine used should be sufficient to do the final mounting in, as otherwise more pure turpentine must be added later. They are immediately placed in the desiccator once more and allowed to remain until all the alcohol has been removed and the specimens are

in pure turpentine, which is about as thick as the thick solution of balsam recommended. They are now transferred to a slide with sufficient turpentine to cover and treated from this point on like balsam mounts.

The Venice turpentine requires a long time for drying (in this respect being like the natural balsam).

(d) Mounting for Study by Ultra-Violet Light

When research work with ultra-violet light of a wave length less than 3,000 angstrom units is to be done, the mounting fluid must be such as to transmit these wave lengths. Moreover, even the slides and covers must be special. For this purpose quartz slides and covers are available and must be used if the wave lengths employed are under 2,750 a.u. If, however, this latter — the cadmium spark line of the Zeiss ultra-violet outfit — is the limit, special ultra-violet transmitting slides and covers are available, the light loss of which is only about 25 per cent. The quartz slides and covers are very expensive.

Only a few media, suitable for mounting, transmit these short wave lengths, the principal ones being glycerine and petroleum oil (Nujol). For solid mounting, embedding, etc., Vinylite Resin A is a good transmitter of the 2,750 a.u. wave length.

When these materials are used in combination with ultra-violet transmitting glass or quartz, the general problems involved do not differ from ordinary mounting.

(e) The Preparation of Ground Sections

Materials too hard for microtome or free-hand sectioning which are to be studied by transmitted light must be reduced to the required thickness by grinding the sections. Such materials are bone (when not decalcified), teeth, shells, many synthetic resins and artificial molding compounds, cement, rocks, and minerals. Most of these are encountered only occasionally in ordinary work, but in petrography, an important branch of microscopical science dealing with the rocks and minerals, this becomes the principal method of preparation.

In describing the various steps of the process, we shall assume that

we are dealing with rock sections in which practically every variation of texture found in any material may be encountered; by this means the application of the method to other substances will be fairly well covered.

Ordinarily the rock to be studied will occur in massive form. As the grinding process is quite slow and tedious, we do not want to do more of it than absolutely necessary. Therefore our first step will be to secure a small flat piece on which to work. If no slicing equipment is available, a chip must be broken from the large piece. With a little practice this can be produced by striking an edge of the rock with a blow parallel to one surface, the chip so broken off usually being wedge-shaped. It need not be greater than $\frac{3}{8}$ " in diameter.

When a grinding wheel, hand or power, is available, some of the thicker part can be removed by rough grinding and one side flattened as much as possible.

For producing a large quantity of slides, it is a great help to be able to cut chips instead of breaking them off. There are two general methods of accomplishing this. The first is to employ either the thin ($\frac{1}{8}$ ") carborundum grinding discs or carborundum slitting saws in a power grinder. The former require a high speed (minimum at least 3,500 r.p.m.) if it is to be used dry; the latter can be run at lower speed but must be kept wet.

The more common method is to use a soft steel disc charged with diamond dust or carborundum. As the rock must be held in a rigid support, movable only in the plane of the cut, this work requires special machines. They are on the market as unit outfits,* or, if one has sufficient mechanical ability, a machine which will do the work can be homemade.

As the pieces cut by machine have flat surfaces and can be made as thin as one or two millimeters, the time saved in grinding the sections is appreciable.

The first grinding operation is to finish one surface,† just as it is to be in the final condition. For the grinding a few simple pieces of

*E. Leitz can supply such a machine.

†No attempt is made in this brief description of the process to outline the methods of mass production with automatic or multiple grinding required for doing the work on a commercial scale. It is assumed that the reader will have only occasional use for this knowledge and that his work will all be done by hand.

additional equipment will be required, and also a few grades of carborundum. These include, first, a cast-iron plate with a flat top surface, 8 to 12 inches in diameter, and a piece of plate glass of about the same size. At least three grades of carborundum are desirable, No. 120 for coarse grinding, No. 200 for fine grinding, and No. 600 for finishing. If a still finer, semipolish finish is desired, a fourth material, the American Optical Company's No. 302½ emery powder, is also required. For much work this latter is unnecessary. The grinding is done on the iron plate with water and the carborundum powders.

When starting with a chip the No. 120 grade is used first, as it is fast-cutting; then, when the surface is flat, the No. 200 can be substituted for it, as the former leaves a very rough, pitted surface. This is followed by the No. 600 grade and finally by the No. 302½ emery. The smooth grinding with No. 600 carborundum and the No. 302½ emery is done on the plate glass instead of the cast-iron plate, but water is used in the same manner as with the coarse grinding. In all cases the chip is moved around over the plate by the fingers so that it is the bottom of the chip which is being surfaced.

After the grinding of the first surface is completed, it is washed thoroughly so as to remove all particles of the grinding powders, dried, and is then ready for mounting on a glass slip for the purpose of finishing the other surface.

Many workers do not care to take the trouble to transfer sections from the slide on which the final grinding is done to a clean new slide; also, in many cases, the rock section when completed is too friable to hold together when loosened from the supporting glass. Under these conditions the slide to which the section is now to be attached must be a clean, perfect slide. On the other hand, if it is to be transferred after grinding, an old discarded slip can be used for grinding the second side.

It is impossible to finish the grinding of the section without grinding the corners and edges of the slide as well; for this reason many workers prefer to grind the surface of the slide completely with a fine powder before attaching the specimen, if it is to stay on the grinding slide. The ground surface entirely disappears in the balsam under the cover and so does not interfere with the section, but outside the

cover the entire surface is ground and any unsightliness caused by ground corners on a clear slip is eliminated.

The simplest method of attaching the specimen to the slide is by means of Canada balsam. First, the ground surface of the chip is turned uppermost and a little very thin balsam is allowed to flow over it. This is for the purpose of filling every cavity and porous portion of the rock and preventing the trapping of air. The center of the slide is now coated with a considerable quantity of thick balsam and the slide is heated until the solvents are eliminated from the balsam. The latter, when cold, is just hard enough to resist denting with the fingernail.

The hardness of the balsam is rather critical; if too soft it will allow the constituents of the rock to move and break up in the final stage of grinding (the section thereby being ruined), while excessively hard balsam is very brittle and the entire section may leave the slide on the least provocation. Addition of a slight amount of cedar oil to the thick balsam helps to prevent this last condition, but only experience will teach one when the hardness is just right.

After the balsam has been cooked down on the slide, the chip is placed upon it and the slide is heated until the chip can be pressed tightly against the slide. It must then be rested on a cold piece of metal and pressure maintained on the chip until the balsam has hardened. No air bubbles must be present in the balsam. If they are there, the slide must be reheated and they must be squeezed out. When the balsam is hard, the excess can be scraped off from around the chip. It is then ready for grinding the second side.

As the finished section will be only about $\frac{1}{1000}$ " thick, it is apparent that through the use of a glass slide to which it is attached as though it were an integral part, we have increased the thickness of the final section an amount equal to the thickness of the glass slip, have supported the section so there is no danger of breaking it, have provided an easy means of holding it during the grinding operation and, last of all, we have extended its area so that it becomes an easy matter to keep the surfaces of the section fairly parallel.

Grinding of the second side is accomplished in the same manner as that of the first; the coarse carborundum is used until the thickness is about that of a visiting card, then the finer grades are used.

The change to the No. 600 is made while an appreciable thickness still remains.

The final thickness to which petrologists ordinarily work is around 30 microns but this thickness can be determined optically only by one familiar with petrographic methods for recognizing the amount of birefringence. For those interested in producing brilliantly polarizing rock sections, the thickness should be greater than 30 microns, 50 or 60 being a better figure; quartz and the feldspars then give a higher order of color.

Assuming that anyone making rock sections possesses a polarizing outfit, the best way of obtaining the desired thickness is to watch the progress of the grinding by periodic examination with polarized light under the microscope. As there is very little chance of a novice's grinding a section too thin at the start, it can usually be assumed that when the colors are pale, the thickness is excessive. A positive proof of this will be the presence of several orders of colors around individual grains or the edge of a section of a single mineral. Grinding should continue until only the first and second orders, at the most, remain. The brilliance of the colors will then be at a maximum. Great care must be taken, when the section is approaching completion, that it is not ground too far or the section will completely disappear. It takes only a few seconds to remove a thousandth of an inch, and this is the thickness toward which one is working.

When the grinding is complete, if the section is to remain on the slide it is ready for covering. It should, however, be washed off well with xylol so as to eliminate grinding powders and any balsam remaining around the section. Addition of balsam and a cover completes the job.

To transfer the section, the slide should be placed in a petri dish, covered with xylol, and heated carefully over a burner (using several layers of wire gauze or a plate) until the xylol starts to boil. The balsam will very quickly be dissolved and the section will float free from the slide. It can then be lifted with a section lifter to fresh xylol for rinsing and to a clean slide.

The technique of making sections of other materials will follow the general outline given for rocks, but slight variations must be made to suit individual conditions.

(f) *Polishing and Etching of Metals*

The study of internal structures of opaque materials by the aid of polished and etched surfaces is confined almost exclusively to metals. The technique involved in the preparation of any similar opaque material which could be studied in this manner will not differ materially from that used for metals; consequently, we shall consider only the latter in this brief description of the process.

Metallography is a science differing so radically from other branches of microscopy and involving so many different metals and alloys — ferrous and nonferrous, ranging from extremely hard to extremely soft, each requiring its own slight modification of technique, both as to polishing and etching process — that no attempt can be made to cover the subject from a metallurgical point of view. It is only because a general outline of the technique and the underlying principles involved may be of value to the general microscopist that we discuss it here.

Metals are not homogeneous in structure. In a pure metal, the mass as we are accustomed to think of it is composed of minute crystal grains. Due to processes of manufacture — casting, rolling, heat treating, etc. — the size and crystalline form of the grains may differ materially, and these variations have their effect on the physical and sometimes the chemical properties of the metal. When metal is alloyed, more complex structures and other constituents may be present.

The purpose of a metallographical study of a metal is to ascertain the physical structure as to grain size, constituents, foreign particles, etc., which may be present. What is required in order to do this is to secure an ideal plane across the metal (sometimes in more than one direction) on which the various constituents are delineated under the microscope when illuminated by reflected light.

Grinding and polishing will produce the plane surface, but when produced, the polished surface usually behaves like a mirror and appears structureless.

It is the purpose of the etching to bring out the different structures through differences in the way in which they react to the etchant.

The grinding operations are performed — after a preliminary flat surface is secured by means of a file or rough-wheel grinding — by

rubbing the surface on emery or carborundum papers of various grades laid on a flat surface such as a piece of plate glass.

The first paper is relatively coarse, No. 1 grade emery, and this is followed with No. 0, then No. 00 and No. 000, the latter often being the finest paper required, although 4-0 and 5-0 are also sometimes used. In each case the sample, which should preferably be about $\frac{1}{4}$ " to $\frac{1}{2}$ " cube, is moved back and forth over the paper in one direction only so that all the scratches are parallel. Each time, however, that the sample goes to a finer paper the direction of the scratches is changed 90° , making the new ones cross the previous marks. The grinding should continue in every case until the previous marks have disappeared and then at least as much longer as the time it took to get rid of them. The reason for this is that the effect of the scratching upon the metal goes deeper than the actual depth of the scratch and all this effect must be got rid of, as well as the scratches themselves.

After the final paper, it pays to continue rubbing on a well-worn piece of the same grade, once more changing the direction 90° . The sample is then ready for polishing.

For the polishing operation, it is almost essential to use a power-driven horizontal disc. This is covered with a fine grade of canton flannel or other smooth cloth, free from grit and hard fibers. The polishing is done with levigated alumina, magnesium oxide, or other polishing powder, in water. Whatever polishing powder is used should be mixed with a considerable quantity of water to form a milky solution, and then allowed to settle for some minutes until larger particles have settled out. The top is then decanted for use.

Polishing must continue until no scratches are visible, even under the microscope, and the surface is a perfect mirror. It is then ready for etching.

Etching agents must be such that the surface is only slightly clouded; consequently, in most cases, they are very dilute solutions of acids, alkalis, or salts, which will attack some of the constituents of the metal.

Among those commonly employed are 3% nitric and 5% picric acid in alcohol for steel and iron; ammonia and hydrogen peroxide for brass and bronze, some alkali for aluminum, etc. Ammonium per-

sulphate and cupric chloride are also frequently used for both ferrous and non-ferrous metals.

Stronger acids are used for gold and precious-metal alloys. For the pure metals of this group aqua regia or even electrolytic attack in aqua regia may be required.

Each individual constituent may require a different treatment to identify it positively.

After etching it is customary to study a metal immediately, as corrosion changes may take place very quickly. Often a surface can be protected for a considerable time for future study by flooding the surface with cedar oil. This hardens, however, and must be dissolved off with xylol before use of the specimen at a subsequent date.

FIXING AND PRESERVING AGENTS, STAINS, ETC.

The following list of fixing agents, stains, etc., is not intended to cover all the important ones in current use. Nor does it cover all that would be essential for every class of tissue. Rather, it has been kept to a minimum of working agents and stains which a beginner might need. They should therefore be supplemented by others especially applicable to specific uses just as soon as one has mastered the underlying principles involved in this phase of mounting technique.

Alcohol

Absolute alcohol in considerable quantity is a fair fixing agent, but 95% is not desirable except where shrinkage is not objectionable; 70–75% alcohol is one of the best preservative agents.

Formalin

A good fixing agent in 10% strength for small organisms where cell structure is not the important consideration. For preserving, 5% is better, as the stronger solution may harden too much, especially if sectioning is to be done.

Chromic Acid

A good fixing agent in combination with others, but shrinks tissues excessively. Like formalin, in strong concentration it hardens organic materials.

Acetic Acid

An important fixing agent in combination, as its tendency to swell tissues and cells can be made to offset the common effect of most others to shrink them.

Osmic Acid

This is the tetroxide of osmium. It is one of the most rapid killing and fixing agents known; even the vapors from a 2% solution kill and fix small organisms in a few minutes. Thus in combination with chromic and acetic acids it is employed for fixation of cells during mitosis. (See Fleming's solution.) It possesses two great drawbacks, however.— its high cost (\$5 to \$6 per gram) and its powerful vapor, which can cause serious effects even on human beings. It is supplied in sealed glass tubes which can be broken under water to make a 2% solution. Another serious objection to it is that it blackens fat tissue and also decomposes even in a 1% to 2% solution, and hence may become valueless after a time.

Phenol

Crystallized carbolic acid. An important chemical for the microscopist. In combination it is a good fixing and preserving agent for some organisms. It is a fine clearing agent, alone and in combination. In combination, when added to turpentine, xylol, and others, it will absorb a considerable quantity of water and allow the solutions to remain clear.

Bichloride of Mercury

A fine killing and fixing agent in combination but tends to precipitate crystals in the tissues which must be dissolved out with a solution of iodine in alcohol.

Chrome-Acetic Mixture

One of the standard combinations for botanical work. Different organisms require different proportions to effect the best results, but the average mixture is about 1% of chromic acid and 1% acetic acid in water. Limits vary from 2% chromic with $\frac{1}{2}$ % acetic to $\frac{1}{2}$ % chromic and 2% acetic. After several hours' fixation, specimens must be well

washed in water for several hours or they will not take some stains. Too long in the fixer hardens specimens excessively while too much washing tends to soften and disintegrate them.

Fleming's Solution (strong)

Composed of 1% chromic acid 45 parts, glacial acetic acid 3 parts, and 2% osmic acid 12 parts. One of the best of cell-structure fixatives but pieces must be small or the solution will not penetrate.

Mueller's Fluid

An old-time fixing agent now largely discarded but still a fine preserving agent, and of value with some classes of nerve and brain tissue. Composed of 25 grams potassium bichromate and 10 grams sodium sulphate in 1,000 cc. of water. Tissues can be left in it for a long time without injury.

Zenker's Fluid

A popular fixing agent for human histological and pathological work, supplanting Mueller's for this purpose. Is the same as the latter with the addition of 5% mercuric chloride and 5% glacial acetic acid. Fixation is complete in 8 to 10 hours, after which tissues must be well washed in water.

Delafield's Haematoxylin

Four grams of haematoxylin are dissolved in 25 to 35 cc. of pure alcohol, then added to 400 cc. of a saturated solution of ammonia-alum in water. This should be allowed to stand for a few days exposed to the air. Then add 100 cc. of glycerine and 100 cc. of methyl alcohol. This solution should also be left exposed to the air, until it turns dark, when it should be filtered and bottled. Although it can be used as soon as dark, it works better after a month or so and keeps for years. It should be greatly diluted for use.

Eosin, Yellowish, Water Solution

This stain in a 1% solution is largely employed as a counterstain after haematoxylin.

Ziehl's Carbol-fuchsin

Basic fuchsin, 1 gram; carbolic acid crystals, 5 grams; alcohol 10 cc., in 100 cc. of water. This is recommended as a nuclear stain after differentiation in alcohol; it is also one of the best and most intense stains known, staining almost everything. When heated it stains *B tuberculosis*, and other acid-fast bacteria, also spore forms. Will stain all bacteria, starches, wood, fibers, and many other substances.

Safranin

Can be used as a pure alcoholic stain or, preferably, a 50–50 alcohol and water stain and is a good all-around stain for wood, xylem, lignin in conjunction with a haematoxylin stain for cellulose.

Iron-Haematoxylin (Heidenhain)

This is the classic stain for chromosomes in mitosis, but the technique is somewhat tedious. The stain itself is a saturated solution of haematoxylin in water, which requires a week or two to reach saturation. The tissues are mordanted for a few hours in a 2½% solution of ferric-ammonium sulphate. From this, after thorough washing, they go into the stain for several hours. This gives a general staining which must be differentiated by being put back into the ferric-ammonium sulphate solution (which should be made somewhat weaker). The sections require watching under the microscope until they are properly differentiated. Counterstain with eosin if desired.

Methylene Blue

One of the most common blue stains in the aniline series and good to use in combination. A 1% aqueous solution suffices.

Giemsa Stain

This is the most popular stain for blood smears, parasitic protozoa, etc., but is an expensive and difficult stain to prepare. It is better to buy the stock solution as prepared by some company specializing in stains.

The stains employed in it are Azur II-Eosin and Azur II, among the most expensive of the aniline series. The stock solution is greatly

diluted for use (about one drop to 1 cc. of water). The smears to be stained with it should be fixed in methyl alcohol and stained smear side down so as to avoid any precipitation forming on the side.

Glycerine Jelly

A semi-solid mountant for objects directly from water. Gelatine 1 part, glycerine $1\frac{1}{2}$ parts. Soak the gelatine several hours in cold water, then remove and warm until melted, when the glycerine should be added. Solid when cold, but turns liquid on warming. Specimens are taken from water, placed on a slide, covered with the warm fluid jelly, and set aside to cool. They should be ringed for complete protection.

Farrant's Medium

A substitute for glycerine jelly. Gum arabic 4 oz., glycerine 2 oz. Not much used at present, but still, a valuable mountant.

Lacto-phenol

A watery solution, fine for mounting, but requires careful sealing to preserve. Phenol 20 parts, lactic acid 20 parts, glycerine 40 parts, and water 20 parts.

Mayer's Albumen

For cementing serial sections to the slide. White of egg 50 cc., glycerine 50 cc., salicylate of soda 1 gram. Mix well together and place in deep test tube to settle. After several days pour off clear top and discard any sediment.

Decalcifying Agent

For the purpose of decalcifying bone for sectioning with a microtome, one of the best agents is nitric acid, greatly diluted (1% to 5%); dilution should depend on the size and age of the bone.

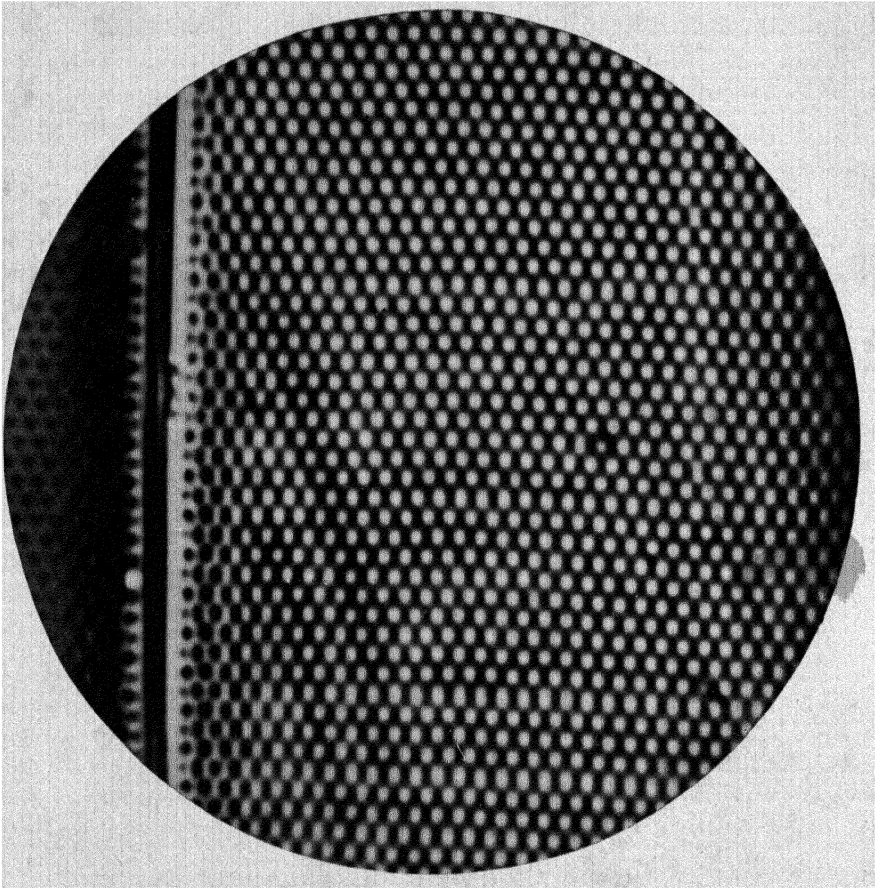

PLATE I. DIATOM, *PLEUROSIGMA ANGULATUM*; $\times 4,500$

The rows of dots on this particular specimen average 45,000 to the inch. Their typical appearance as resolved at the so-called "white dot" focus, by a high class apochromat of 1.10 N.A. is well brought out in this micrograph at a direct magnification of 4,500 diameters.

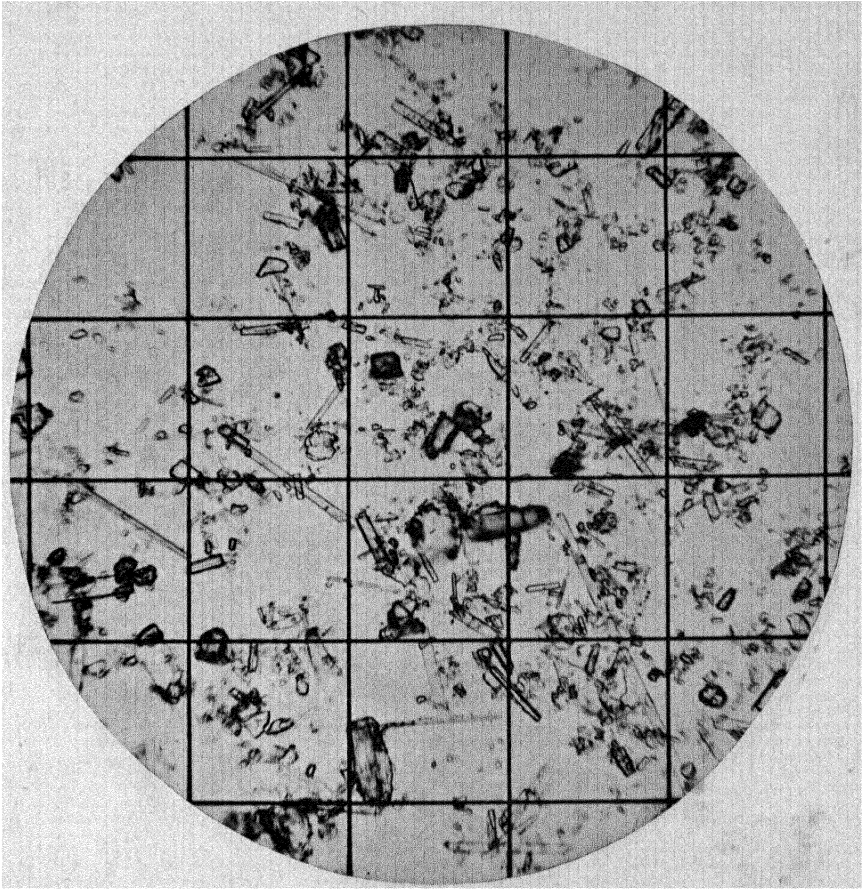

PLATE II. FIBROUS TALC; $\times 500$

An example of the manner in which a clear, transparent material with a refractive index near to that of the mounting medium can be delineated by stopping down the illumination cone until a black line appears around the individual particles.

This micrograph also illustrates the use of a net micrometer ruling in the eyepiece for counting and size determination. The spaces in this instance are practically identical with the size of opening in a 325 mesh screen.

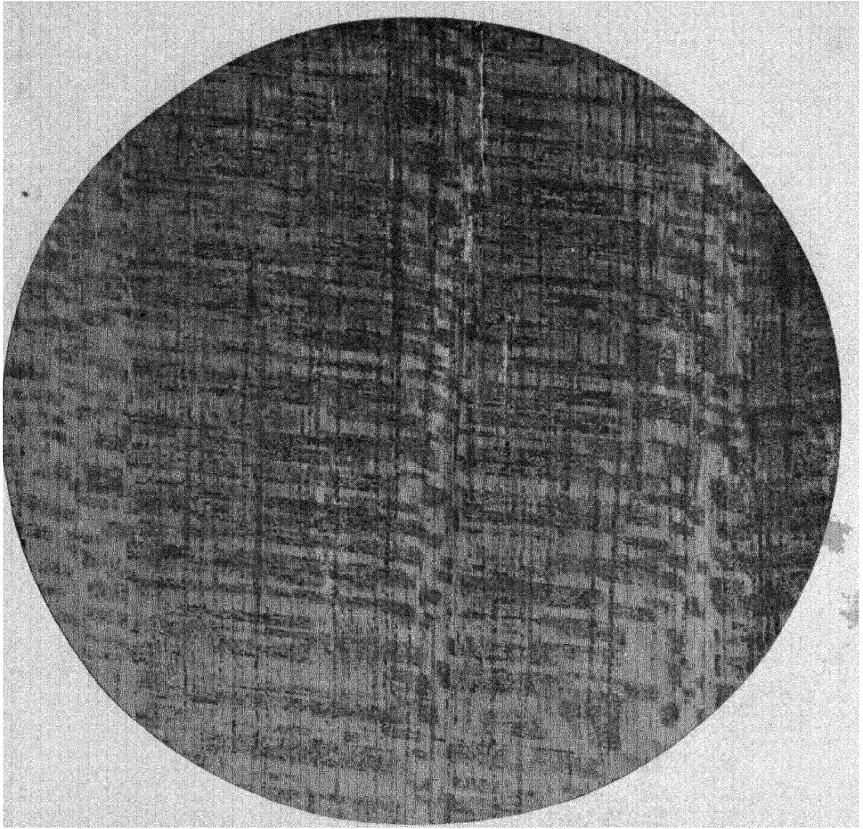

PLATE III. LIGNITE COAL: $\times 25$

A thin section, almost opaque in superficial appearance, when illuminated by an intense light shows a deep red, capable of being photographed on a panchromatic plate as seen in this micrograph. The original wood structure, in radial section, is evident.

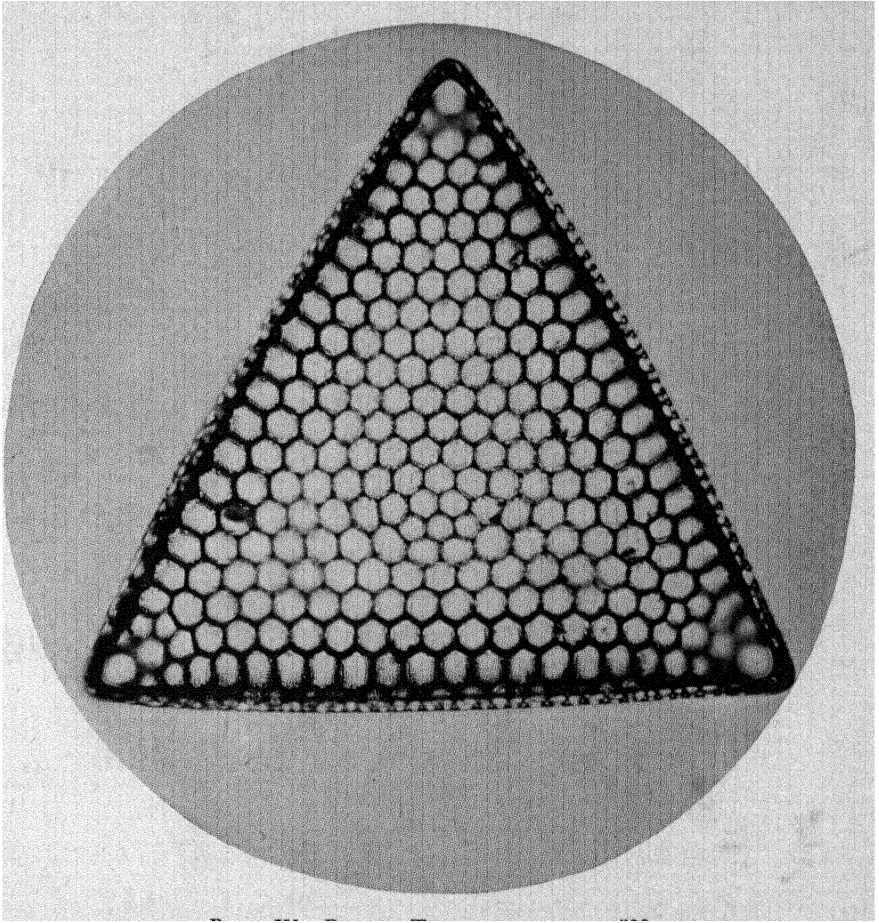

PLATE IV. DIATOM, TRICERATIUM FAVUS; $\times 500$

The siliceous frustule, as cleaned and mounted for test purposes. The primary markings, of a honeycomb-like structure are relatively coarse and serve for testing low power lenses. There is a finer secondary dot structure, faintly discernible at this magnification. In this micrograph the focus is definitely on the frustule surface and the depth of focus is relatively slight.

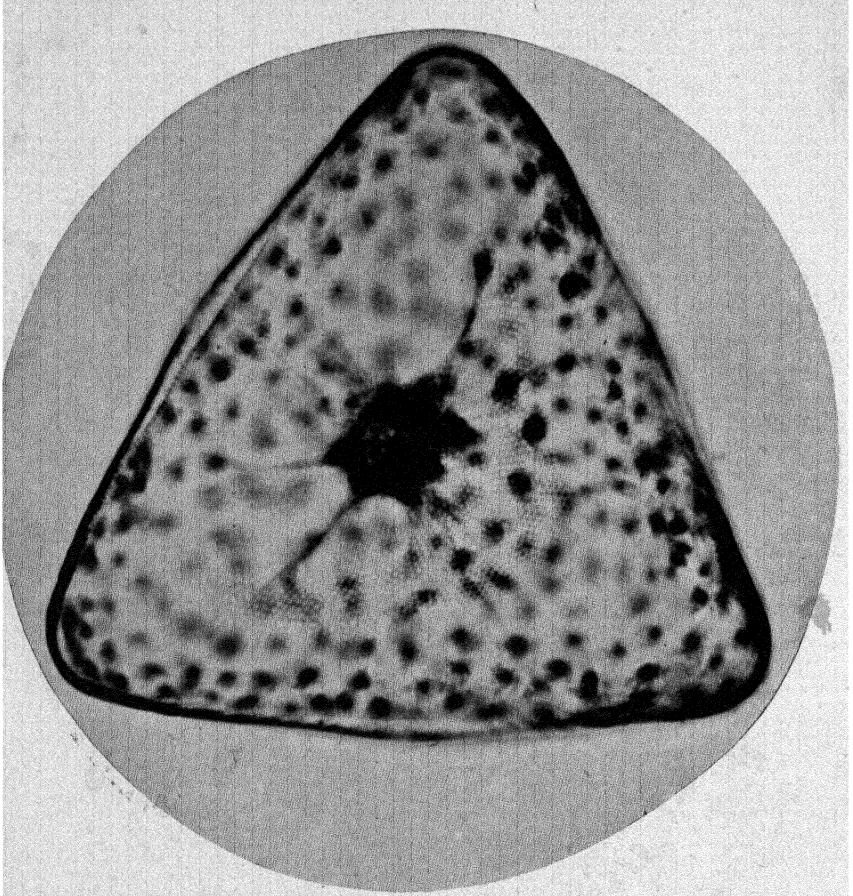

PLATE V. DIATOM, TRICRATHIUM, SHOWING CELL STRUCTURE; x500

This is a somewhat smaller species than *T. favus*, with finer markings. It has been fixed and stained directly from the living state, so as to reveal the protoplasmic contents of the cell.

Through the use of a lense with relatively low aperture, a considerable depth of focus has been secured, even at a fairly high magnification. The markings on the frustule are faintly visible, also the nucleus lying in the center of the cell, with numerous plastids (the black dots), those on the bottom valve being out of focus.

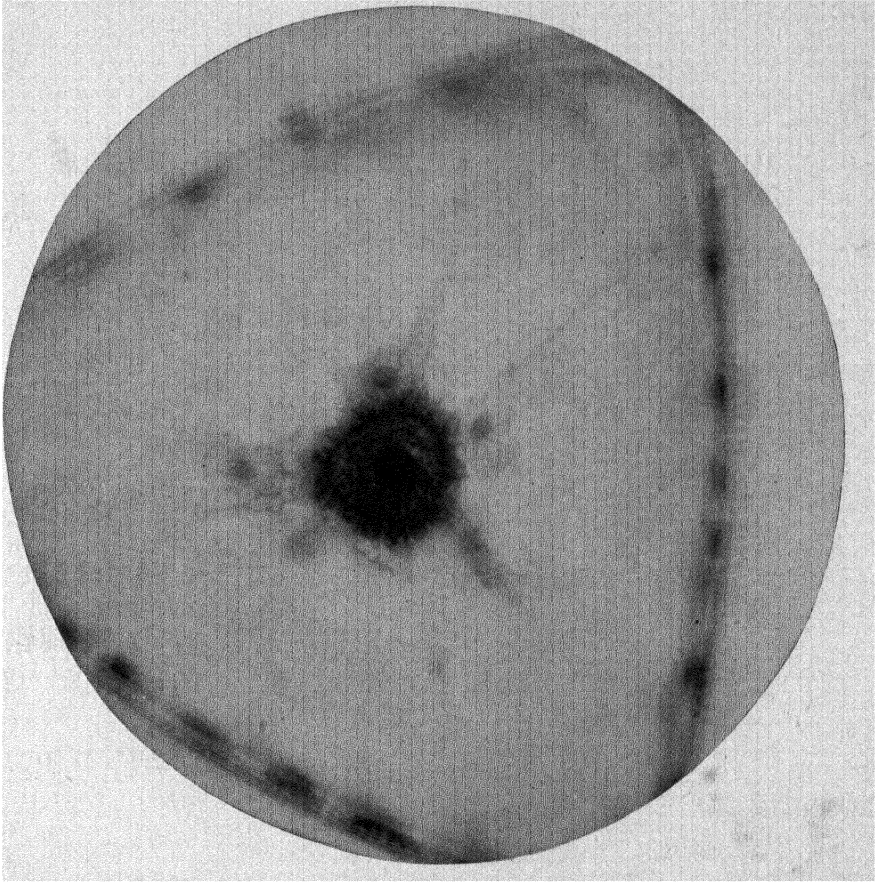

PLATE VI. DIATOM, TRICRATIUM, AT LEVEL OF THE NUCLEUS; $\times 1,000$

By the employment of a lens of higher aperture (resulting also in a higher magnification) an optical section of a cell such as shown in Plate V can be obtained, at any desired level.

In this micrograph the level chosen passes through the nucleus and nucleolus. All structures lying above and below this level are so much out of focus that they completely disappear.

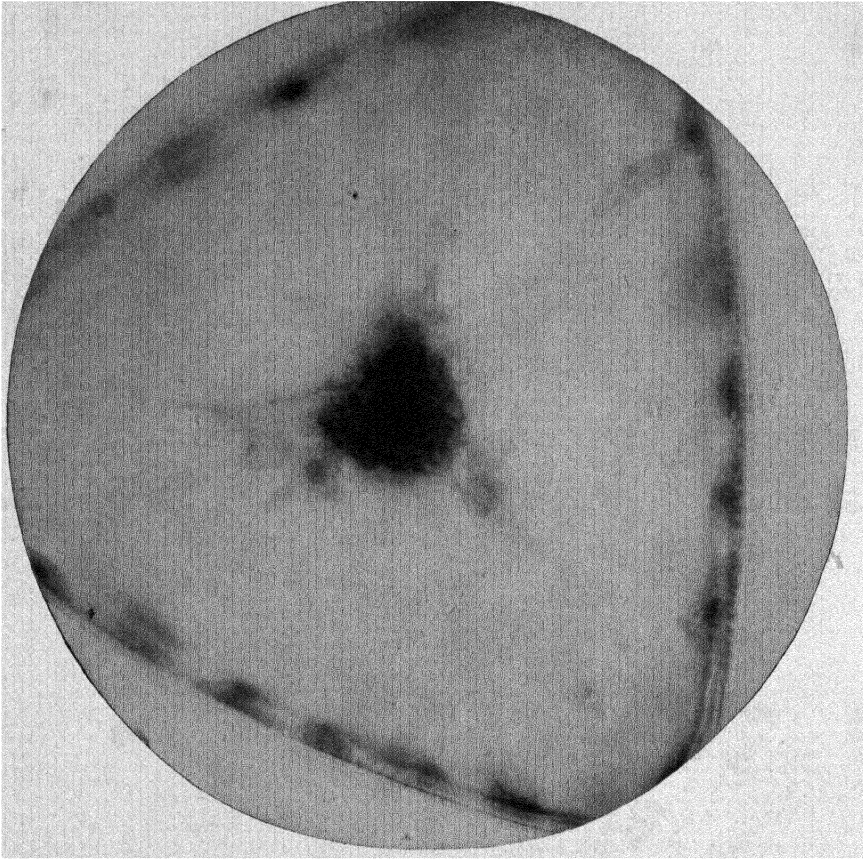

PLATE VII. DIATOM, TRICRATIUM, AT STILL LOWER LEVEL; $\times 1,000$

The same specimen as that shown in Plate VI, with the focus slightly altered so as to cut the nucleus at a level just below the nucleolus. Note that the protoplasmic strand located at about one o'clock in Plate VI which disappears at the top due to a dipping down is now seen to connect with a plastid, although the connection to the nucleus is no longer evident.

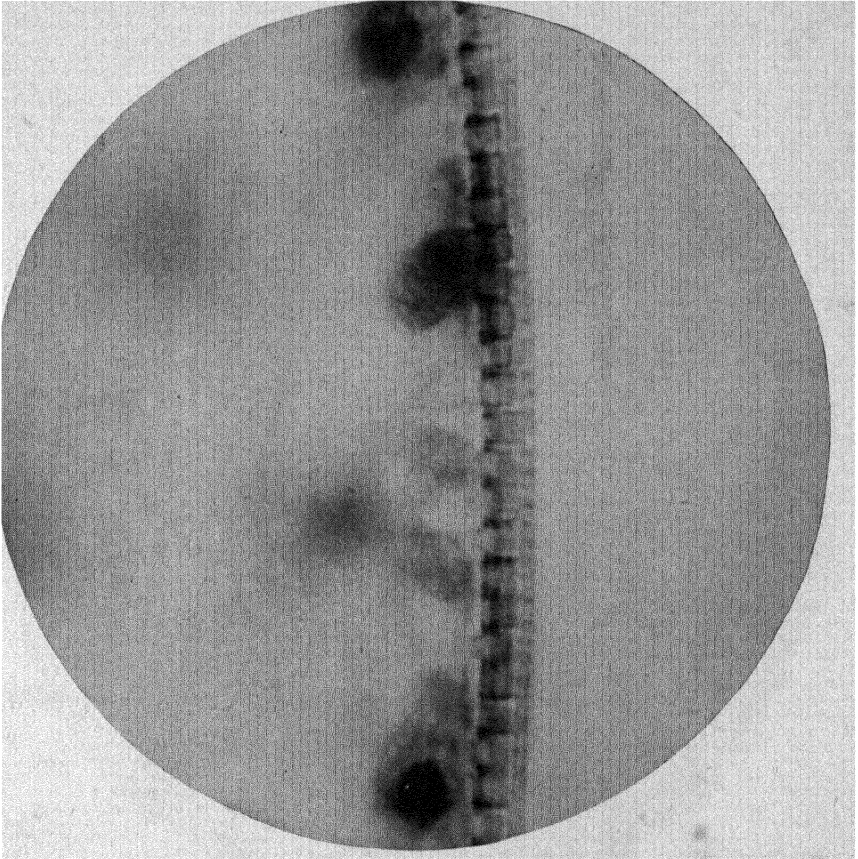

PLATE VIII. THE VALVE WALL OF TRICERATIUM, IN OPTICAL SECTION; $\times 2,500$

To secure the optical section shown in this micrograph involves the utilization of every possible refinement in both apparatus, and technique. A 1.40 N.A. apochromat in combination with a 1.40 N.A. aplanatic condenser, oiled for full aperture, provides the ideal optical system, but the great amount of recurring structure in the vertical wall above, and below the plane of focus, interferes to an appreciable extent with the perfection of the image.

It is interesting to note that the section reveals the amoeboid plastids projecting pseudopodia into the interior depressions in the wall, indicating the manner in which the cell is nourished.

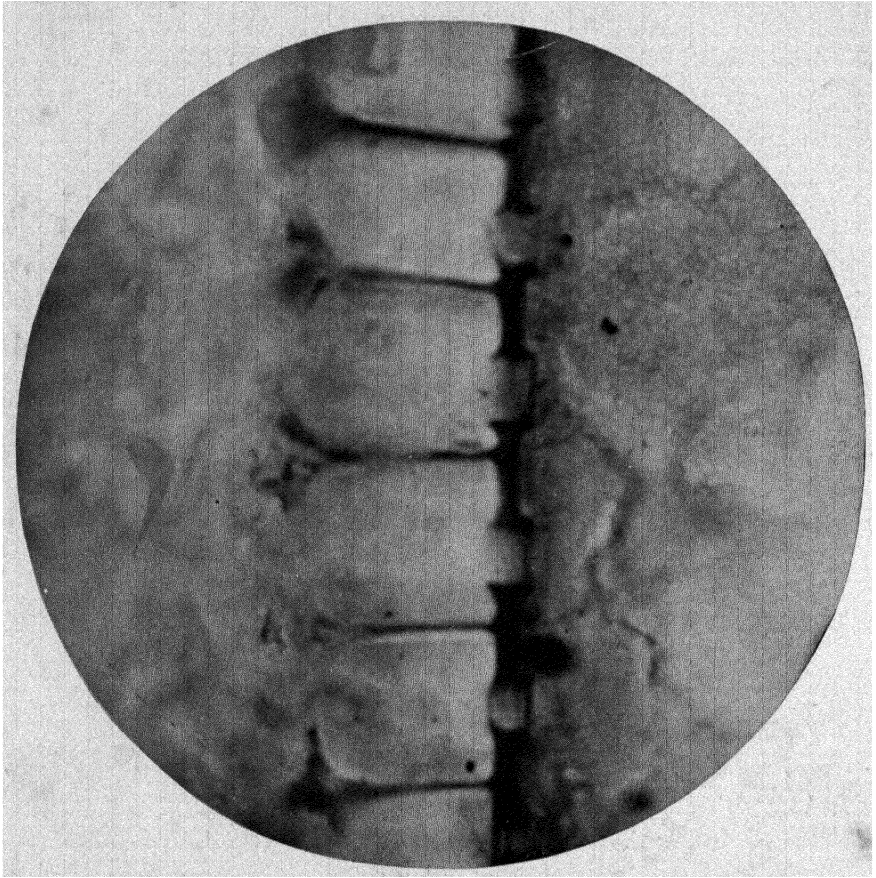

PLATE IX. "CEMENTSTEIN," WITH DIATOM WALL IN OPTICAL SECTION; $\times 3,000$

This sedimentary rock encloses occasional diatom frustules, offering an opportunity to study the wall structure of the latter in optical section. The problem in this case is one of obtaining the image in spite of the rather small differential between the refractive indices of the diatom and the embedding rock matrix. Sometimes, to secure results under this condition, it may be necessary to employ a lower apertured illuminating cone.

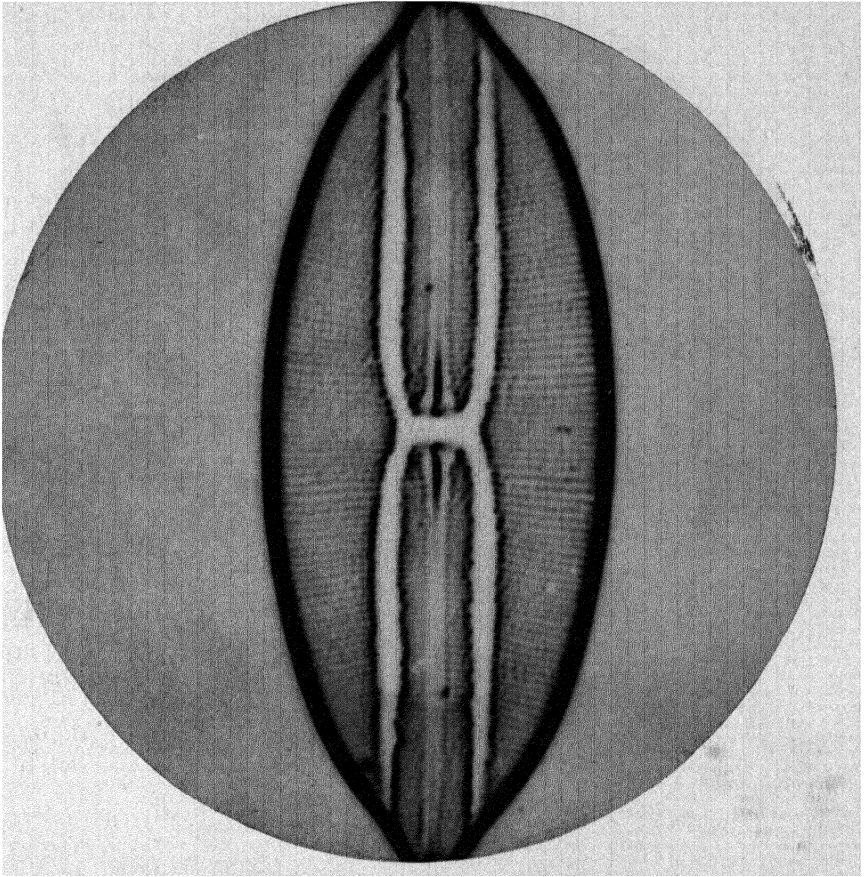

PLATE X. DIATOM, NAVICULA LYRA; $\times 1,000$

This shows the resolution of the markings obtained with a lens of N.A. .30. If one had no higher apertured lens with which to examine it, the conclusion might be reached that this is a good interpretation of the actual structure, but comparison with Plate XI shows the fallacy.

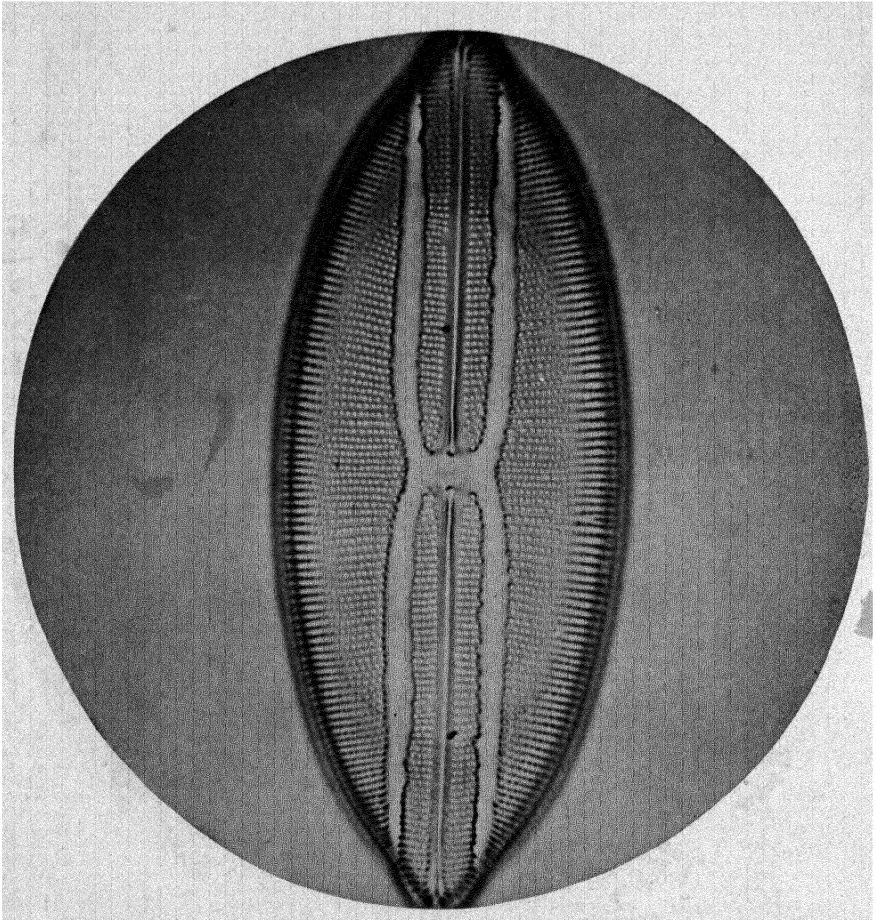

PLATE XI. DIATOM, NAVICULA LYRA; $\times 1,000$

The same diatom shown in Plate X, but shown with a lens of N.A. .65, which is capable of revealing the true nature of the markings. The great difference in the central area, at the terminations of the raphae, should be noted, as well as the brilliance of the bead-like markings.

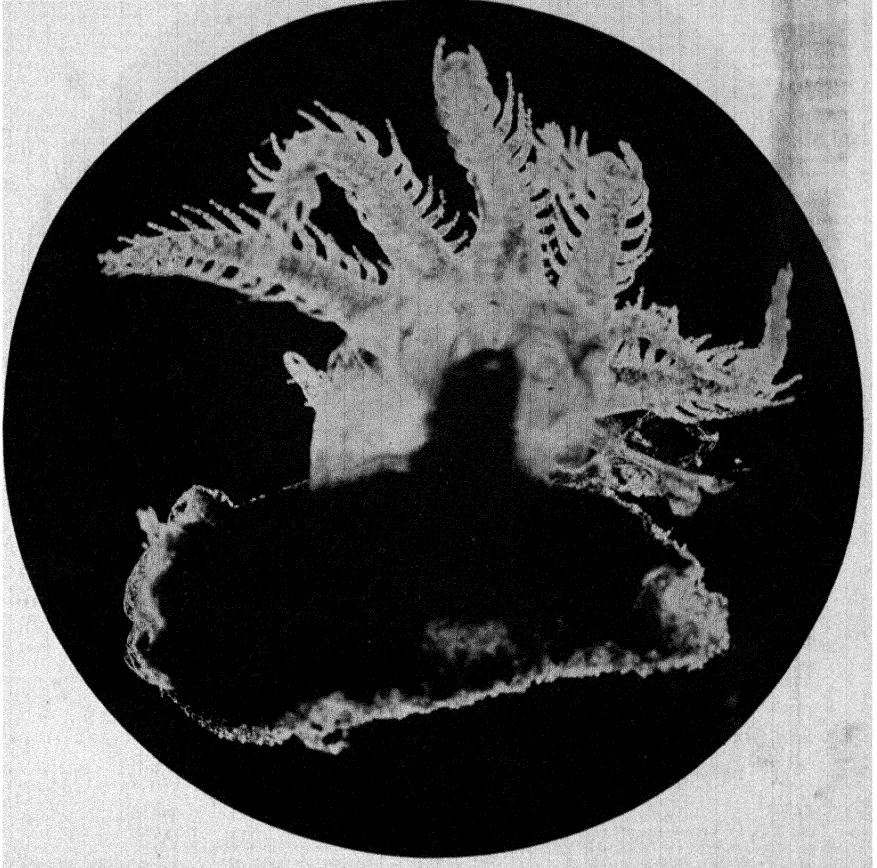

PLATE XII. RED CORAL POLYP, BY DARK FIELD; $\times 15$

An example of dark field applied to a large object, at low magnification. In this instance dark field was secured through the use of a stop such as shown in Figure 74.

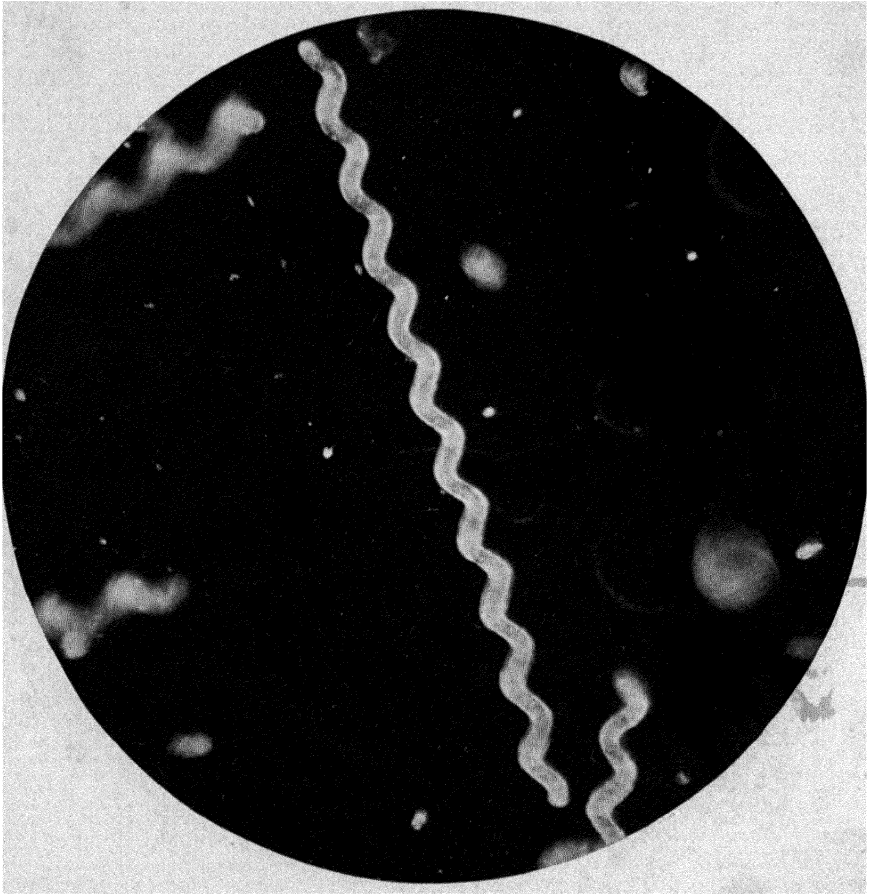

PLATE XIII. *SPIRULINA JFNERII*, BY DARK FIELD; $\times 500$

This organism, only slightly higher in the scale of life than the bacteria, is well adapted to demonstrate the value of dark field in the study of unstained specimens in their natural condition. The numerous light circles are diffraction effects from minute particles lying outside the focus. They are commonly present in dark fields unless the object be a flat smear, and their presence must be ignored.

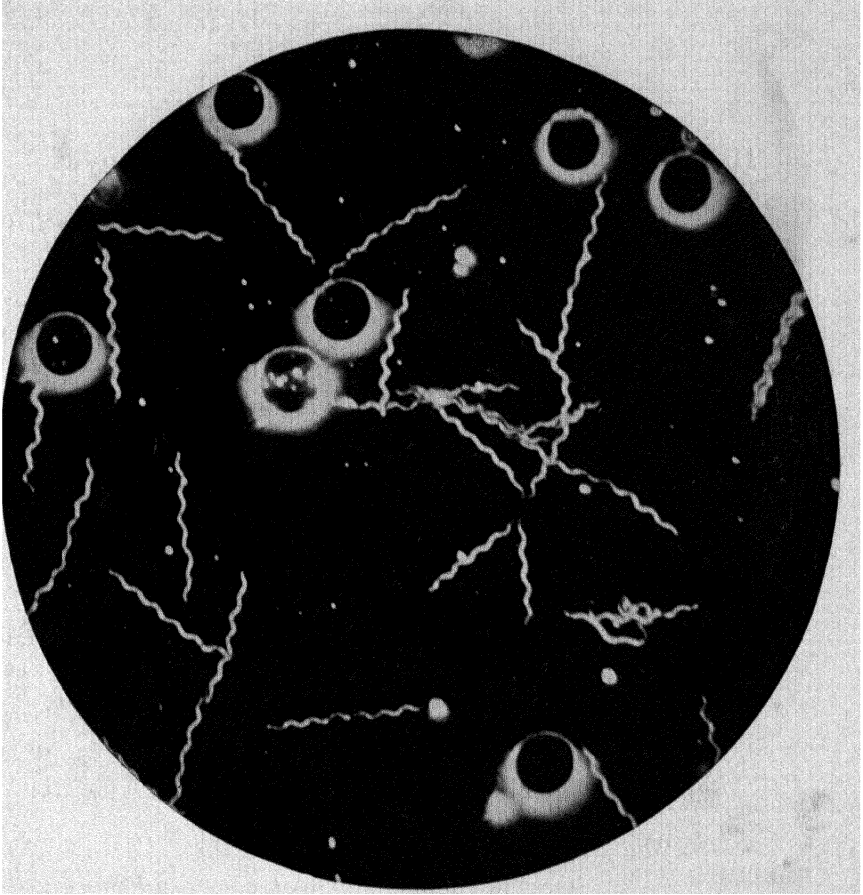

PLATE XIV. SPIROCHAETE OF RELAPSING FEVER, BY DARK FIELD; $\times 1,500$

Taken with an immersion lens exceeding N.A. 1.00 in combination with the Zeiss Leuchtild Condenser, and illustrating the remarkable resolution obtainable when a high apertured objective can be employed.

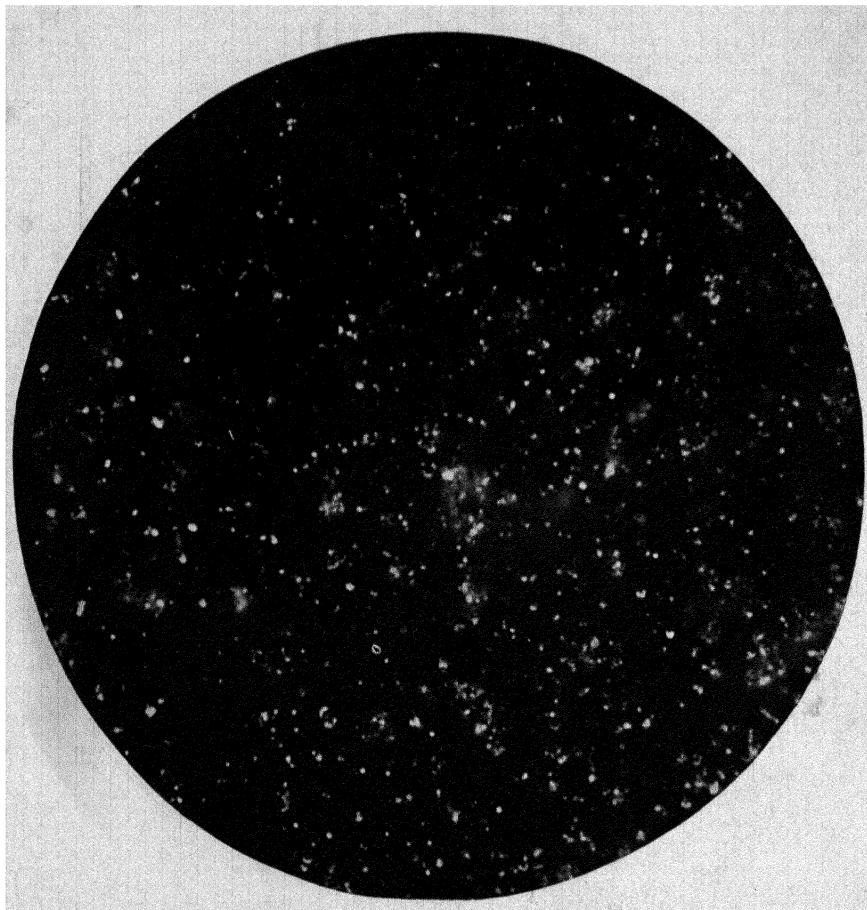

PLATE XV. COLLOIDAL LEAD, BY DARK FIELD; $\times 1,500$

Dark field is particularly adapted to the visual study of colloidal solutions such as this, but the photographing of them is another matter as the particles are in constant motion, due to pedesis. Even with the very short fractional part of a second exposure given this micrograph there is some motion evident.

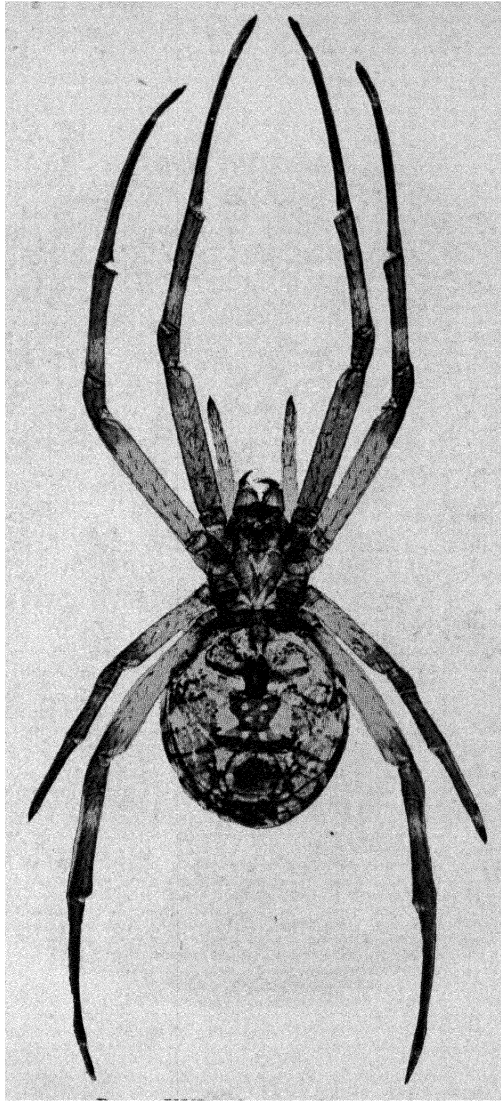

PLATE XVI. GARDEN SPIDER; $\times 2$

This micrograph illustrates the size of this class of objects which can be satisfactorily mounted by the pressure method, also the manner of arranging the legs and parts on the slide. The specimen, the well known garden spider (*Miranda aurantia*, female), is nearly three inches long and the abdomen a thick oval ball in the living state. Nevertheless it has been pressed to the form shown until the impression is given one that it has been *painted* on the slide.

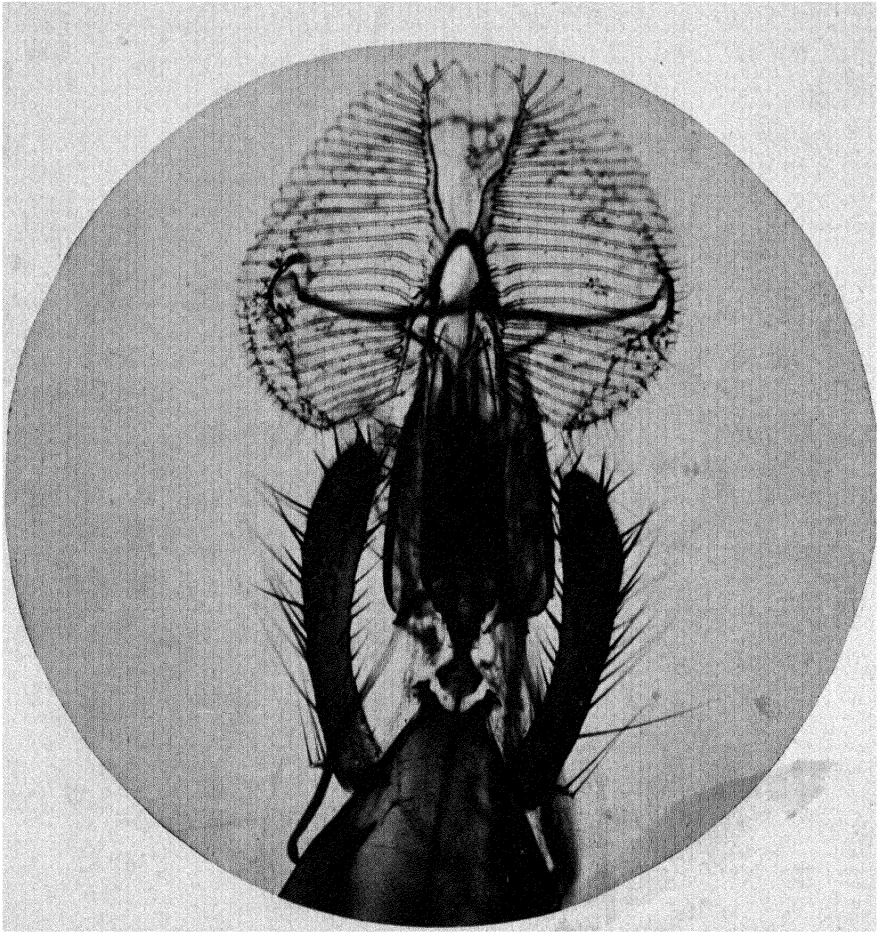

PLATE XVII. PROBOSCIS OF HOUSE FLY; $\times 75$

That detail structure can be well revealed by the pressure method of mounting insects is demonstrated in this micrograph. In no other way can the structure of the tubes in the lobes of the house fly (*Musca domestica*) proboscis, which is of the lapping type, be shown. Skill and practice are both essential, however, in the arranging of the parts in the expanded condition.

BIBLIOGRAPHY

The following list of books covers most of those published (in English only) on various phases of microscopy. From it have been omitted works published during the very early days of the microscope. The difficulty of obtaining these latter and the fact that they are of only historical value make undesirable their inclusion in a list of practical books.

A complete bibliography would necessarily include references to numerous periodical articles, as well as references to journals and magazines issued by microscopical societies, technical associations, and independent publishers. There are also many books of interest on related subjects such as optics, light, lenses, etc., that are of interest if one is to delve deeply into the history, theory, and practice of the microscope. In other words, to be complete a bibliography could be extended almost *ad infinitum*. One of more value, for practical purposes, to the general microscopist would include only references useful to him, whether he be an amateur hobbyist or a specialist. This latter method has been followed here.

This list is divided into various groups for the saving of time and patience. Notes are given on some books in order to point out certain features.

In the list of reference books on subjects closely related to microscopy, to have listed all of value, or even all the important ones, would have been impossible. Only sufficient are included to show where additional information on a given subject can be obtained.

The name of the book, as here the matter of more vital interest, is given first, rather than that of the author. Furthermore, books have been arranged to give first those which are generally recognized by microscopists as of marked value. This listing should not, however, be construed as arbitrarily preferring one book as above another simply because it comes first in the list, for this obviously could not be done where several are of equal merit.

GROUP I

General Microscopy, Optical Principles, Microscopical Technique, Microtomy, etc.

Most of the following books can be classed as modern and more or less up to date. A few may be out of print but new printings or editions come out as a demand for them materializes.

The Microscope. Simon Henry Gage. The Comstock Publishing Co. (16th ed. 1936)

One of the best works on the microscope published in the United States. Is very thorough from the standpoint of the general biologist but lacking in specific botanical technique. Written largely as a textbook and kept up to date by frequent new editions.

The Microscope and Its Revelations. William B. Carpenter. Revised by Rev. W. H. Dallinger. P. Blakiston's Son & Co.

This is an American revision, starting with the 7th edition, of the English classic on the microscope, by William B. Carpenter. In size it is the most pretentious of all works on the subject, the *Micrographic Dictionary* (out of print) alone excepted. It covers the theory, design, and operation of the instrument and contains much material on microscopic objects.

Microscopy. E. J. Spitta. E. P. Dutton (N. Y.)—John Murray (London)

One of the best works on the theory and operation of the microscope, testing of lenses, etc.

The Microtometist's Vade-Mecum. A. Bolles-Lee. P. Blakiston's Son & Co.

The standard work on section methods, killing, fixing, embedding, staining. The 9th edition (1928) has been completely revised, by several collaborators, from the previous English editions.

The Microscope, Vols. I and II. Conrad Beck. R. & J. Beck (London)

A popular English work on the microscope. Vol. I is a preliminary, non-technical covering of the subject; Vol. II is for more advanced study.

Handbook of Microscopical Technique. Edited by C. E. McClung. Paul B. Hoeber, Inc.

A collaboration by twenty-four workers in various fields, covering the micro-technique of preparation and examination of plant and animal tissues. Written largely from the standpoint of the medical field.

Adventures with the Microscope. J. D. Corrington. Bausch & Lomb Optical Co. (1934)

A popularly written book, intended especially for beginners.

Modern Microscopy. M. J. Cross and M. J. Cole. Chicago Medical Book Co.

The Use of the Microscope. John Belling. McGraw-Hill Book Co.

Principles of Microscopy. Sir Arthur E. Wright. The Macmillan Co.

Practical Methods in Microscopy. Charles H. Clark. D. C. Heath & Co.

Critical Microscopy. Alfred C. Coles. J. & A. Churchill (London)

Introduction to the Use of the Microscope. C. R. Marshall and H. D. Griffith. Routledge (London)

The Microscope, a Practical Hand Book. Lewis Wright and A. H. Drew. Religious Trace Society (London)

Analytical Microscopy, Its Aims and Methods. T. E. Wallis. Edward Arnold & Co. (London)

The Book of the Microscope. Gerald Beavis. J. B. Lippincott Co. (1931)

How to Use the Microscope. Charles A. Hall. A. & C. Black (London)

GROUP II

Older Works on General Microscopy

The books listed below are out of print, but can often be picked up in second-hand book stores. Occasionally, reprint editions of the more popular appear on the market. These books were great favorites of the past generation.

Micrographic Dictionary. J. W. Griffith and Arthur Henfrey. (A guide to the structure and nature of microscopic objects.) (1st ed. 1855. 3rd ed. 1875)

More of an encyclopedia than a dictionary. Covers largely the microscopical aspects of biological structures and contains much information and abundant illustrations which are still of value. Illustrated by 48 plates and 812 woodcuts. Copies usually sell secondhand from \$15 to \$25.

The Microscope and Its Revelations. William B. Carpenter

Part I deals with the instrument and its operation while Part II covers microscopic objects as revealed by the microscope. Editions up to the 6th (1891) are often available. The 7th and later editions have been revised by W. H. Dallinger, and published in the United States, hence are listed under the more modern books.

The Microscope. Jabez Hogg. (1st ed. 1854. 12th ed. 1887. 15th ed. 1898)

The scope of this book is about the same as Carpenter's *The Microscope and Its Revelations*. Very interestingly written and contains much information on plant and minute animal life, polarization effects, etc., and is abundantly illustrated.

The Preparation and Mounting of Microscopical Objects. (1874) Thomas Davies

The title is descriptive of the nature of the book. Interesting from historical standpoint but very much out of date as to methods.

The Microscopist. J. H. Wythe. (1853. 4th ed. 1883)

Methods of Research in Microscopical Anatomy and Embryology. Charles Otis Whitman. (1885)

Manual of Microscopical Technology. C. Friedlaender. (1885) Translated by S. Y. Howell.

How to Use the Microscope. (1875) John Phinn

Microscopy in the Service of Man. Robert M. Neill

The Microscope in Theory and Practice. Translated from the German. Carl Naegeli and S. Schwendener. (1892)

Manipulation of the Microscope. Edward Bausch. (1st ed. 1885) Bausch & Lomb issue yearly *Use and Care of the Microscope*, a new pamphlet based on the original.

Practical Microscopy. (1889, England) George E. Davis

A Popular Handbook to the Microscope. (England) Lewis Wright

Elementary Microscopy. (1912, England) F. Shillington-Scales

How to Work with the Microscope. (5th ed. 1880, London) L. S. Beale

GROUP III

Older Works on Objects Revealed by the Microscope

The following books were written for the amateur microscopist or such readers as were interested only in the wonders of various forms of life as revealed by the microscope. In most cases the titles are fairly descriptive of the contents.

- Views of the Microscopic World.* (1851, New York) John Brocklesby
Evenings at the Microscope. (1859) Philip Henry Gosse
Common Objects of the Microscope. (1861) J. G. Wood
One Thousand Objects for the Microscope. M. C. Cooke
Objects for the Microscope. (1871) L. Lane Clarke
Through a Microscope. (1886) Wells, Treat, and Sargent
Microscopy for Beginners, or Objects from the Ponds and Ditches. (1887)
 Alfred C. Stokes
Half Hours with the Microscope. (1874) Edwin Lankester
Marvels of Pond Life. Henry J. Slack
Minute Marvels of Nature. (1904) John J. Ward

GROUP IV

The Microscope in Specialized Use

The fact that the microscope is such an important factor in many branches of science necessitates reference to books written more from the standpoint of specific lines of research, the microscope being in such cases but a means to an end. For the benefit of workers in some of the principal fields, a few additional references are given below. It is believed that those chosen are of special value from the microscopical viewpoint.

A. General Plant and Animal Histology

Fresh Water Biology. Henry B. Ward and George C. Whipple. John Wiley & Sons.

Very valuable for the study of lower forms of aquatic life.

Animal Micrology. Michael F. Guyer. University of Chicago Press. (1936)

Methods in Plant Histology. Charles J. Chamberlain. University of Chicago Press

Very fine for methods in the botanical field.

Handbook of Practical Botany. Strasburger. Translated from the German by Hillhouse. The Macmillan Co.

Botanical Microtechnique. Zimmerman. Translated from the German. Henry Holt & Co.

Histological Technique. B. F. Kingsbury and O. A. Johannsen. John Wiley & Sons. (1935)

Principles of Micro-Biology. V. A. Moore. The Macmillan Co.

Guide to the Study of Histology and Microscopic Anatomy. Avery E. Lambert. P. Blakiston's Son & Co.

Plant Anatomy and Hand Book of Micro-Technique. William C. Stevens. P. Blakiston's Son & Co.

The Life of Inland Waters. J. G. Needham and J. T. Lloyd. Comstock Publishing Co.

The Cell in Development and Inheritance. Edmond B. Wilson. The Macmillan Co.

The standard work on the structure of the cell.

The Diatomaceae of North America. Rev. Francis Wolle

This is considered one of the most complete and important contributions to the subject published in the United States, although not up to date. It is out of print. Copies can be secured only secondhand and usually bring a fairly high price.

B. Applied Microscopy in Various Fields

The Microscopy of Technical Products. T. F. Hanansek. Translated by Andrew L. Winton. John Wiley & Sons

The Microscopy of Drinking Water. G. C. Whipple. John Wiley & Sons

The Microscopy of Vegetable Foods. Andrew L. Winton and J. Moeller. John Wiley & Sons

Textile Fibers. J. Merritt Matthews. John Wiley & Sons

Modern Textile Microscopy. J. M. Preston. Emmot & Co., London. (1933)

Textiles and the Microscope. E. R. Schwartz. McGraw-Hill Book Co.

Identification of the Timbers of Temperate North America. Samuel J. Record. John Wiley & Sons. (1934)

Plant Disease Fungi. F. L. Stevens. The Macmillan Co.

Phytopathological and Botanical Research Methods. Thomas Ellsworth Rawlins. John Wiley & Sons. (1933)

C. Pathology, Bacteriology, Parasitology, etc.

Practical Bacteriology, Blood Work, Parasitology. E. R. Stitt. P. Blakiston's Son & Co.

Pathological Technique. Frank Burr Mallory and James Homer Wright. W. B. Saunders Co.

Principles of Micro-Biology. V. A. Moore. The Macmillan Co.

Microbiology Applied to Nursing. Jean Broadhurst and Lila I. Given. J. B. Lippincott Co. (1934)

D. Chemical Microscopy, Petrology, Mineralogy, and Crystallography

Elementary Chemical Microscopy. Vols. I and II. E. M. Chamot and C. W. Mason. John Wiley & Sons

Petrology for Students. Alfred Harker. Cambridge University Press. (7th ed. 1935)

Petrographic Methods. Ernst Weinschenk. Translated by Robert Watson Clark. McGraw-Hill Book Co.

Manual of Petrographic Methods. Albert Johannsen. McGraw-Hill Book Co.

A Descriptive Petrography of the Igneous Rocks. Vols. I and II. Albert Johannsen. University of Chicago Press. (1937-1938)

Thin Section Mineralogy. A. F. Rogers and P. F. Kerr. McGraw-Hill Book Co.

Essentials for the Microscopical Determination of Rock-Forming Minerals and Rocks. Albert Johannsen. University of Chicago Press

Minerals in Rock Section. L. M. Luquer. D. Van Nostrand Co. New edition in preparation

Rock Minerals. Joseph P. Iddings. John Wiley & Sons.

E. Metallography

Practical Microscopical Metallography. Greaves and Wrighton. Chapman & Hall (London)

The Microscopic Analysis of Metals. F. Osmond and J. E. Stead. Griffin & Co. (London)

Metallography and Macrography. Leon Guillet and Albert Portevin. McGraw-Hill Book Co.

The Metallography and Heat Treatment of Iron and Steel. Albert Sauveur. McGraw-Hill Book Co. (4th ed. 1935)

The Microscope in Elementary Cast Iron Metallurgy. Roy M. Allen. American Foundrymen's Association

Microscopic Examination of Steel. Henry Fay. John Wiley & Sons.

Metallic Alloys. G. H. Gulliver. Griffin & Co. (London)

Introduction to Physical Metallurgy. Walter Rosenhain. Constable & Co. (London)

Cast Iron in the Light of Recent Research. W. H. Hatfield. Griffin & Co. (London)

F. Photomicrography

Handbook of Photomicrography. H. L. Hind and W. B. Randles. E. P. Dutton & Co.

Practical Photomicrography. J. E. Barnard and F. V. Welch. Longmans, Green & Co.

Photomicrography, An Introduction to Photography with the Microscope. Eastman Kodak Co.

DEALERS IN MICROSCOPICAL SLIDES

Frequently beginners desire to know where mounted slides can be secured. The following issue catalogues and can supply slides on almost any subject.

Eimer & Amend, 3rd Ave. & 18th St., New York, N. Y.

General Biological Supply Co., Chicago, Ill.

Marine Biological Laboratory, Woods Hole, Mass.

New York Scientific Supply Co., 111-113 East 22nd St., New York, N. Y.

Powers and Powers, Lincoln, Nebr.

Ward's Natural Science Establishment, Rochester, N. Y.

GLOSSARY

The following words, relating to microscopy, the microscope, and its manipulation, are in more or less use among microscopists. In addition to defining the words, an attempt has been made to give, where desirable, further information which may be of value to a beginner. No attempt has been made to include words relating to mounting technique as it would be difficult to draw the line as to what should be included and what omitted.

A

Abbe, Analyzing Eyepiece
See *Eyepiece*.

Abbe, Apertometer
See *Apertometer*.

Abbe, Condenser
See *Condenser*.

Abbe, Test Plate
See *Test Plate*.

Aberration, Chromatic

A defect inherent in a simple lens, caused by violet light being refracted more than red light, hence, instead of a point of white light coming to a focus to form a white light image, it has a rainbow band of colors around its margin.

Aberration, Spherical

A defect occurring in a lens having a spherically ground surface, caused by the rays through the marginal zones being refracted more than those in the central zone and hence having a shorter focus.

Achromatic

The absence of chromatism or color due to chromatic aberration. When applied to a lens, implies one in which chromatic aberration has been corrected for two colors in the spectrum, the others being folded over so as to neutralize each other as far as possible.

Adjustable Stage
See *Stage*.

Adjustment, Coarse

The rack and pinion adjustment of the microscope tube, extending over a total movement of several inches. In cheaper models effected by means of a sliding tube.

Adjustment, Fine

The micrometer focusing device, for bringing an object into the position of exact focus, even under extremely high magnification, the total movement being limited to one or two millimeters.

Affluent Rays

Rays of light proceeding toward a refracting surface. Synonym for *Incident Rays*.

Amicroscopic

So small as to be invisible under the microscope. (See also, *Sub-microscopic*, and *Ultra-Microscopic*.)

Analyzer

The polarizing prism (or other means) used above the objective to repolarize light from the polarizer after its passage through the object on the stage.

Anastigmatic

Not having astigmatism; correction of astigmatism by means of a lens having a cylindrically shaped surface instead of spherical.

Angle of Incidence

The angle which an incident ray makes with a perpendicular to the refracting surface at the point of contact.

Angle of Refraction

The angle which an emergent ray makes with a perpendicular to the refracting surface at the point of emergence.

Ångström Unit

The tenth meter, or 1/10,000 of a micron. Employed especially in designating the length of a wavelength of light to four whole numbers.

Angular Aperture

The angle of the cone of light which enters the front lens of an objective from the axial point on the object plane. Originally used to define the light gathering and resolution characteristics of objectives, is now superseded by the term **numerical aperture** (q.v.)

Apertometer

A device for measuring the angular and numerical aperture of an objective through detection of the marginal rays of greatest angularity which can just enter the lens. Originally designed by Abbe, several modified forms are now available.

Aplanatic

Corrected for spherical aberration so that central and marginal rays focus at the same point.

Achromatic

Of a higher order of correction than achromatic, i.e., a lens in which spherical aberration is corrected for two colors and chromatic aberration for three.

Arm (microscope)

The portion of the microscope supporting the tube, extending to the inclination joint.

Aspheric

Not having the shape of a sphere. A lens ground so that the rays of light from the marginal zones focus at the same point as the central zone rays, i.e., correction is thus made for spherical aberration. Such a lens cannot have a spherical surface, hence the name.

Astigmatism

A defect in a lens or optical system in which rays in one plane come to a focus at a different point from those in the plane at right angles to it. In the microscope it is especially noticeable in the image after the passage of the rays through an analyzing prism.

Axis, Crystallographic

See *Crystallographic Axis*.

Axis, Optic

See *Optic Axis*.

B

Babinet Compensator

See *Compensator*.

Base, (microscope)

Either the horseshoe foot alone, or the combined foot and pillar when these are of one piece. In the English type, the tripod foot supporting the instrument.

Berek Compensator

See *Compensator*.

Bertrand Lens

A lens placed in the tube of a petrographic microscope, serving in combination with the eyepiece, as a supplemental microscope for viewing the interference figure formed in the plane of the back lens of the objective, under conoscopic methods of examination.

Biaxial (Crystallography)

Having two optical axes, as in the Orthorhombic, Monoclinic and Triclinic systems.

Binocular Microscope

A microscope with separate eyepieces, (and sometimes separate objectives) for each eye.

Binocular Vision

The observation of an object or image by both eyes. When accomplished by the eyes alone, or by separate magnifying units for each eye, results in stereoscopic or three dimensional effect, due to the parallax angle between the eyes.

Biot Compensator

See *Compensator*.

Birefringence

The property, possessed by all crystals except those in the isometric system, of having more than a single refractive index, depending upon the direction in which the light is passing through the crystal.

Also birefringence can be produced in other than crystalline materials (e.g. glass) by internal or external strains, and is present in materials possessing a different structure in different directions (e.g. fibers, etc.).

Brownian Movement

See *Pedesis*.

Bull's Eye Condenser

See *Condenser*.

C

Camera Lucida

A device for mounting over the eyepiece of a microscope, arranged so that a horizontal sheet of paper located at the side of the instrument can be seen superimposed on the field of view and a tracing of the object made on the paper.

Cap Analyzer

A polarizing prism designed to mount over the eyepiece to function as an analyser, instead of being located between the eyepiece and objective.

Cardinal Plane

See *Principal Plane*.

Cardioid Condenser

See *Condenser, Dark Field*.

Cell, (apparatus)

Any kind of a container made from transparent material for holding liquids through which light must be passed.

Cell, Cooling

A large cell containing water or a solution for absorbing heat rays from a high-power light source, to prevent damage to the object or lenses.

Cell, Filter

A cell containing a colored solution functioning as a light filter.

Cell, Quartz

(a) A cooling cell having quartz windows for use in ultra-violet work.

(b) A special cell used in connection with dark field condensers. (See *Quartz Cell*.)

Chromatic Aberration

See *Aberration*.

Chromatism

The presence of color fringes around an image due to lack of correction (or under- or over-correction) for chromatic aberration.

Coarse Motion

See *Adjustment, Coarse*.

Coherent Light

See *Light, Coherent*.

Coma

A haze or fuzziness in the image formed by an objective in which the sine law has not been properly fulfilled. Not commonly present in modern objectives.

Comparison Eyepiece

See *Eyepiece*.

Compensator

An optical device for determining the extent of retardation or birefringence present in a mineral section or crystal,

through compensation or neutralization of the order of interference color present.

Among the types in common use are, the *selenite* and *mica plates*, *quartz wedge*, *Berek compensator*, *Babinet compensator*, *Biot compensator*, etc.

Compensating Eyepiece

See *Eyepiece*.

Compound Microscope

A microscope in which double magnification is secured through a primary magnification (by the objective) producing a real image which is further magnified by the eyepiece as a virtual image, seen by the eye.

Concavo-Convex

A convex or positive lens which has one concave surface, but of greater radius of curvature than that of the convex surface. A positive meniscus lens.

Condenser (substage)

A lens or combination of lenses, located beneath the stage of the microscope for the purpose of properly illuminating an object for examination by transmitted light.

Condenser, Abbe

An uncorrected substage condenser developed by Abbe, which when oiled to the slide would give a cone of illumination for the two lens type of N.A. 1.20 and for the three lens type of N.A. 1.40. The predecessor of all modern substage condensers.

Condenser, Achromatic

A substage condenser corrected for chromatic aberration and usually for spherical aberration (one color) also.

Condenser, Aplanatic

A substage condenser corrected for spherical aberration.

Condenser, Bull's Eye

A large diameter (2 to 3 inches), short focus single lens condenser

mounted on a base and adjustable for height, position, etc., for concentrating a beam of light on an opaque object or projecting parallel light onto the substage mirror.

Condenser, Dark Field

A condenser especially designed for producing dark field illumination. There are many different designs, the two most common being the *Parabaloid* and *Cardioid*. Of these the former is preferable for most work, and easier to use, also less affected by changes in slide thickness. The latter gives a more critical point illumination and is therefore a better approximation of the slit ultra-microscope.

Condenser, Spectacle Lens

A simple low power condenser for use with very low power objectives.

Confusion, Disc of

See *Disc of Confusion*.

Conical Illumination

A form of illumination employed with vertical illuminators for metallographic work, in which the central, or axial rays are blocked out so the illuminating is effected by means of a hollow cone of light.

Conoscopic Observation

The method of observing the interference figure of a mineral or crystal formed by strongly convergent light, on the plane of the back lens of the objective. The Bertrand lens becomes in this case the viewing objective and the object the back lens of the microscope objective.

Converging Rays

Rays which are symmetrically drawing together as they progress, so that they will ultimately meet to form an image of the point from which they originated.

Convexo-Concave

A concave, or negative lens which has

one surface convex, but of greater radius of curvature than that of the concave surface. A negative meniscus lens.

Counting Chamber

A specially designed heavy slide in which a cell has been ground, having an exact depth so that when covered with an optically flat cover, the volume of the cell per unit of area is accurately predetermined. The floor of the cell is graduated with some form of net ruling to enable particle counts to be made on a volume basis.

Cover Glass

The thin glass disc, round, square or rectangular, preferably of a thickness around .18 mm., used for covering a prepared object.

Cover Glass Micrometer

A mechanical device for measuring the thickness of cover glasses, slides, etc. in terms of 1/100th of a millimeter.

Critical Angle

The angle of total internal reflection. That angle which represents the dividing line between rays which can just leave a dense medium and travel into one less dense, parallel to the surface of contact and rays which cannot get out of the dense medium but must be internally reflected back into it.

Critical Illumination

Illumination of an object, in which the condenser forms an image of the illuminating source in the plane of the object with an angular aperture equal to that of the objective.

Crossed Nicols, (Crossed Prisms)

The condition where the vibration directions of the polarizer and analyser are at 90° to each other, so that light admitted by the former is completely eliminated by the analyser, hence with no polarizing object on the stage no light is transmitted to the eyepiece.

Cross Line Eyepiece

See *Eyepiece*.

Crystallographic Axis

The three (hexagonal system, four) directions in a crystal, analogous to length, breadth and height, in their proportions and angular relations to each other, by means of which the characteristics of the crystals in the various (six) systems are defined.

Curvature of Field

The inherent characteristic of an image produced by a lens, in that it does not form on an ideally perfect plane, but on one that is slightly spherical. Hence in a microscope the image is never quite in focus at the margin when sharp in the center, and vice versa.

D

Dark Field Condenser

See *Condenser*.

Dark Field Illumination

The illumination of an object so that it stands out brightly illuminated, with the surrounding field dark. This results from illuminating the object by transmitted light with all rays of sufficient obliquity that none can enter the objective directly. Accomplished by means of diaphragms, spot lens, oblique illumination or dark field condensers.

Demonstrating Eyepiece

See *Eyepiece*.

Depth of Focus

The extent to which the vertical dimension of a transparent object, above and below the exact theoretical focal plane, is in approximate focus with a given objective.

Diameters

The term used to express the ratio of linear magnification of the image to the object.

Diaphragm

Any device for reducing or controlling the aperture of a lens, or the diameter of a beam of light.

Diaphragm, Iris

An adjustable circular diaphragm the opening of which is controlled by means of an external lever, or knurled ring.

Diaphragm, Stop

(a) A diaphragm with a fixed opening.

(b) A diaphragm with the central portion stopped out; i.e. a *Wheel Diaphragm*, a *Dark Field Diaphragm*.

Diaphragm, Slit

A diaphragm in which the opening is a narrow slit instead of circular in shape.

Diaphragm, Davis

An iris diaphragm in a mount for insertion between the bottom of the tube and the objective.

Diaphragm, Traviss

An expanding stop designed on the iris principle, for inserting below the substage condenser to block out the central rays, an adjustable wheel stop.

Diatom

A unicellular alga secreting an outer cell wall of silica on which various fine markings occur. There are many thousand species, with markings from relatively coarse to extremely fine, hence are commonly employed as test objects for determining the quality and resolution of objectives. *Test Plates* and *Type Plates* are available for this purpose.

Dichroscopic Eyepiece

See *Eyepiece*.

Diffraction

Deviation of light rays from a straight line when passing through a minute opening or along the edges of an object or opening. As in refraction, different

wave lengths are usually bent a different amount, hence interference color bands may occur.

Disc of Confusion

The image of a theoretical point source of light, which, because of the undulatory nature of light, can never be an actual point image, but is a circular area of measurable proportions, even with a theoretically perfect lens.

Dispersion

The spreading or separating of the components of white light when it is refracted, due to the fact that the refractive index is different for every different wavelength. Usually it is greater for short waves so that violet is bent more than red when light passes from air into a medium of higher refractive index.

Distance of Best Vision

The nearest point to which a normal eye can focus without introducing eye strain, arbitrarily set for microscopical purposes at 10 inches (250 millimeters).

Diverging Rays

Rays of light which are spreading apart as they advance, hence can never, of themselves, come together again to form an image of the point from which they originated.

Double Concave

A lens with both surfaces concave.

Double Convex

A lens with both surfaces convex.

Drawing Eyepiece

See *Eyepiece*.

E**Effluent Rays**

Rays of light proceeding away from a refracting surface. Synonym for *Emergent Rays*.

Eikonometer (Wright)

An auxiliary device for making measurements under the microscope. It mounts over the eyepiece as a cap and

the image is observed just as with the eyepiece alone, but superimposed on a scale which can be calibrated as with a micrometer eyepiece so as to give readings in terms of the actual size of the object.

Emergent Rays

Rays of light proceeding away from a refracting surface. Synonym for *Effluent Rays*.

Empty Magnification

Magnification in excess of that where the maximum possible resolution is secured.

Equivalent Focus

The focus of a combination of lenses functioning as a single lens, which corresponds to that of a single lens possessing the same magnifying power.

Erect Image

See *Image*.

Extinction Angle

The angle between some recognized crystallographic direction in a mineral section and the planes of vibration of the polarizing prisms when the section is in the position of extinction (darkness).

Eyepiece

The second magnifying element in a compound microscope.

Eyepiece, Abbe Analyzing

An eyepiece of the Huygenian type with an analyzing prism mounted between the eye and field lenses, for use on a standard microscope in combination with a substage polarizer. Gives a superior image to that obtained with an ordinary Nicol prism analyzer mounted directly above the objective.

Eyepiece, Binocular

A separate binocular eyepiece unit which can be substituted for the monocular eyepiece of any microscope so that both eyes may be used in viewing the object.

Eyepiece, Comparison

A device for mounting over two separate microscopes to bring the image from each into one eyepiece where the field of view is split through the center to accommodate both and enable them to be studied side by side.

Eyepiece, Compensating

An eyepiece especially designed for use with apochromatic objectives, overcorrected to compensate for a slight difference in the magnified images of the different colors. Employs either the Huygenian or Ramsden type of design, depending on the magnifying power.

Eyepiece, Cross Line (Spider line)

An eyepiece provided with cross hairs in the plane of the diaphragm, for use in polarizing and Petrographic microscopes.

Eyepiece, Demonstration

A double type of eyepiece, arranged so that two persons can view the same image simultaneously.

Eyepiece, Dicroscopic

An eyepiece having a small rectangular diaphragm with a prism of calcite above it, so that the separate images formed by the ordinary and extraordinary rays may be examined simultaneously, side by side, for the presence of pleochroism.

Eyepiece, Drawing

An eyepiece equipped with a prism for projecting the image onto a horizontal sheet of paper, or one that splits the vision so that the eye may observe the image and the paper simultaneously, for tracing the former on the latter.

Eyepiece, Filar Micrometer

See *Filar Micrometer*.

Eyepiece, Flat Field

A corrected eyepiece of superior quality to the ordinary Huygenian and yielding a flatter field. Each manufac-

turer has his own trade name for the flat field series, to distinguish them from the ordinary and compensating types, e.g., *Hyperplane* (B&L), *Planoscopic* (Spencer), *Periplanatic* (Leitz), *Orthoscopic* (Zeiss).

Eyepiece, Goniometer

An eyepiece equipped with cross hairs and mounted for rotation in a graduated circle so that degrees of rotation may be determined. Used especially in the measurement of the angles between various sides of a crystal, or between cleavage directions. An ordinary cross hair eyepiece can be used as a goniometer eyepiece when a graduated rotating stage is available, the object then being rotated instead of the eyepiece.

Eyepiece, Homal

A special flat field eyepiece made by Zeiss, for photographic purposes only; the eyepoint is located within the lens.

Eyepiece, Huygenian

The most common form of eyepiece in use with achromatic objectives. A negative combination with the field limiting diaphragm between the lens components.

Eyepiece, Micrometer

An eyepiece equipped with an engraved scale in the plane of the diaphragm, for the measurement of objects in the field. The eye lens is usually made with a focusing adjustment, to bring the scale into accurate focus.

Eyepiece, Planimeter

An eyepiece of the micrometer type but provided with a net ruling or other surface subdivisions, for integrating areas, counting particles, etc.

Eyepiece, Pointer (or Indicator)

An eyepiece equipped with a movable pointer located in the plane of the diaphragm and operated from the

outside, for the purpose of indicating a special object in the field.

Eyepiece, Projection

A long focus (low magnification) eyepiece with the Eye lens in a focusing barrel to accommodate it to the specific image distance being employed for projection.

Eyepiece, Ramsden

A positive combination, with the diaphragm below the lenses. Formerly preferred for high-power eyepieces but not much used at present in uncorrected eyepieces.

Eyepiece, Spectrographic

An eyepiece incorporating a small spectrograph with adjustable slit and comparison prism for the study of the absorption spectra of microscopic objects.

Eyepiece, Wright's Universal

An eyepiece provided with a slot for the insertion of various compensators and used with a cap analyzer, for petrographic examinations.

Eye Point

The place above the top lens (eye lens) of the eyepiece where the rays cross and where the eye must be placed to take in the entire field of view. Called variously *Ramsden Circle*, *Lagrange Disc*, etc.

Eye Shade (or Shield)

A device attached to the top of the tube for shielding the unused eye so it may be kept open without extraneous light entering it during the study of a specimen with the other eye.

F

Filar Micrometer

A micrometer, in the form of an eyepiece, for measuring the size of an object under the microscope, in which the measurement is effected by the movement of one of the index lines through an external graduated drum.

Field

The circular portion of an object which is in view with a given combination of objective and eyepiece.

Filter (light)

A transparent colored medium interposed in the light path for giving a definite band of colors and eliminating all other wavelengths. It may consist of a colored solution in a glass cell, a colored gelatine film (mounted or unmounted between glass plates), or a colored glass plate.

Fine Motion

See *Adjustment, Fine*.

Fluorite Objective

See *Objective*.

Focal Plane

The plane, at right angles to the optic axis, passing through the focal point.

Focal Point

See *Focus*, and *Principal Focus*.

Focus

The position where rays from an object located on one side of a lens are brought together on the opposite side to form an image of the object. (a) The position itself. (b) The distance of the focal position from the lens.

Focus, Principal

The focal point (or focal distance) of the image when the object is located at infinity.

Focus, Equivalent

See *Equivalent Focus*.

Focus, Solar

Same as *Principal Focus*.

Focus, Conjugate

The image focal point (or focal distance) corresponding to any given object distance or the converse object distance for a given image distance.

Foot, (Microscope)

The base upon which the microscope rests; specifically the horseshoe shaped

portion, when the upright portion (the pillar) is a separate piece.

Frequency (light)

The number of wave cycles or vibrations occurring per second. It is determined by dividing the distance light travels per second (186,000 miles or 300,000,000 meters approx.), by the wavelength. For example, the frequency of violet light having a wavelength of 4000 angstrom units (.4 micron or .0000004 meter) =

$$\frac{300,000,000}{.000,000,4} = 750,000,000,000,000 \text{ cycles per second}$$

F-Ratio

The ratio between the focal length of a lens and its effective diameter; used as the standard of light transmitting properties. Other conditions being equal, the speed of a lens for photographic purposes varies inversely as the square of the F-Ratio value, i.e., a lens of f/2 is four times as fast as one of f/4.

G

Glycerine Immersion Objective

An immersion objective designed to use glycerine as the immersion fluid.

Goniometer Eyepiece

See *Eyepiece*.

Greenough Binocular

A low-power microscope consisting of two separate magnifying units each complete with objective, eyepiece and a prism erecting body, set close together at an angle of about 15° so each eye sees the object from its own point of vantage. With this instrument a three-dimensional erect image is obtained.

Gypsum Plate

See *Selenite Plate*.

High Aperture

A term commonly used to refer to apertures above N.A. 1.00, but also used in a relative sense as contra to a lower

aperture; e.g., a .85 N.A. 4mm objective would be considered a high apertured lens as compared to one of only .65 N.A.

H

Homogeneous Immersion
See *Objective, Immersion*.

Huygenian Eyepiece
See *Eyepiece*.

I

Illumination, Critical
See *Critical Illumination*.

Illumination, Conical
See *Conical Illumination*.

Illumination, Dark Field
See *Dark Field Illumination*.

Illumination, Köhler
See *Köhler Illumination*.

Illumination, Opaque
See *Top Illumination*.

Illumination, Transparent
See *Transparent Illumination*.

Illuminator, Lieberkuhn
See *Lieberkuhn*.

Illuminator, Silverman
See *Silverman Illuminator*.

Illuminator, Vertical
See *Vertical Illuminator*.

Image (light)

A reproduction or picture of an object in contradistinction to the object itself; especially one produced by a lens.

Image, Real

An image formed by a lens which can be projected on a screen or photographed.

Image, Virtual

An image which can be seen only with the eye and which does not actually exist in space; e.g., one seen in a mirror.

Image, Inverted

An image which is upside down with respect to the object.

Image, Erect

An image which is right side up with respect to the object. An erect image may, however, be transposed with regard to the right and left sides.

Image Distance

The distance of the image plane from the optical center of a lens.

Image Plane

The plane perpendicular to the optic axis, passing through the image focal point.

Immersion Objective

See *Objective, Immersion*.

Incident Rays

Rays of light proceeding toward a refracting surface. Synonym for *Affluent Rays*.

Inclination Joint

The hinged joint between the Arm and Pillar by means of which the tube and stage can be inclined to suit individual needs

Infra Red

See *Spectrum*.

Interference Colors

The spectrum colors seen in a polarizing material placed between polarizing prisms, due to the retardation of one polarized ray and the corresponding suppression by interference of wavelengths where the retardation is one half a wavelength or multiples thereof. The color seen is the white light used for illumination of the specimen minus all suppressed wavelengths. The colors pass through the complete spectrum from violet to red, as the retardation is increased and then start over again. Each spectrum is called an *Order*, (i.e., I, II, III, IV, etc.) and the entire series is known as *Newton's Scale of Interference Colors*.

Interference Figure

The figure observed in the plane of the back lens of an objective under conoscopic observation of a crystal, being in effect polarization or extinction shadows cast by the axis or axes of a mineral where they coincide with the vibration directions of the polarizer and analyzer.

Inverted Image

See *Image*.

K

Köhler (Koehler) Illumination

Illumination of an object, in which the condenser forms an image of the luminant near the plane of the rear lens of the objective, or near its optical center. It thus differs from the so-called Abbe method of critical illumination in that with the latter, the image of the luminant is formed in the plane of the object.

L

Lagrange Disc

See *Eye Point*.

Lamp

The source of artificial illumination employed with the microscope. Generic term for any illuminating device.

Lens

A disc of glass or other transparent substance having at least one surface ground as a segment of a sphere (or cylinder), convex or concave, for the purpose of producing a symmetrical change in the direction of light rays passing through it, by utilization of the law of refraction.

Lens, Negative

A lens with one or both surfaces concave so that it is thinner in the center than in the outer margin. Called negative because it cannot produce a "real" image and neutralizes a positive lens of corresponding focus.

Lens, Positive

A lens having one or both surfaces convex and thicker in the center than in the marginal zones, capable of producing a real image.

Lieberkuhn Illuminator

A concave mirror designed to surround the objective and reflect light coming from below the stage onto an opaque object. Formerly very popular but now not in much use.

Life Box

A special form of slide, having a glass covered cell, in which small animals, especially aquatic forms, can be placed for examination in the living state.

Light

From the microscopical standpoint, primarily those energy transmitting vibrations in the ether of such frequency that they may be picked up by the human eye. They include wave lengths between .4 and .7 microns, the composite of all waves between these limits constituting *white light*. Invisible waves shorter than .4 micron are called *Ultra-violet Light* and those longer than .7 micron, *Infra Red Light*.

Light, Coherent

Light which originates at one point only so that all rays begin in exact phase. Only such rays are able to interfere with each other when out of phase.

Light, Axial

Light which is travelling parallel to the optic axis, or symmetrically disposed about it.

Light, Oblique

All light striking an object at angle to the optic axis, or not symmetrically disposed about it.

Light, Polarized

Light which has been made to vibrate in one plane only instead of at all conceivable angles about the axis of propa-

gation, as is the case with ordinary, or unpolarized light.

Light, Monochromatic

Light of one wavelength only, or at least of so narrow a band of frequencies that they appear of the same color to the eye.

Loup

A magnifying glass. See *Simple Microscope*.

M

Macrograph

A photograph of an object taken at only a slight magnification, usually understood as not exceeding 10 diameters. A contraction of *Photomacrograph*.

Magnification

The extent to which a real or virtual image of an object is increased over the object itself. Usually expressed in terms of *Diameters*, the straight linear relationship. In superficial area the increase is as the square of the diameters.

Magnified

Appearing increased in size, through the production of an enlarged real or virtual image.

Magnifier

See *Simple Microscope*.

Maltwood Finder

A device for locating the position of any particular area or field in an object, for quick future reference. It consists of a network with the squares numbered, photographed on a glass slide, which can be substituted for the slide to be recorded. The numbered square seen in the field corresponds to the position of the area desired.

Mechanical Stage

See *Stage*.

Mechanical Tube Length

See *Tube Length*.

Meniscus Lens

A lens with a convex surface on one side and a concave surface on the other. A concavo-convex or a convexo-concave lens.

Metallurgical Microscope

A microscope specially designed for the study of polished and etched metal surfaces.

Mica Plate

A cleavage of Mica mounted for insertion between the polarizer and analyzer of a Petrographic Microscope, for effecting a predetermined retardation of one of the polarized rays. Mica Plates are available in one-eighth, one-quarter, one-half and three-quarters retardation thicknesses.

Micrograph

A photograph showing a considerably enlarged view of a minute object. Frequently used as a contraction of and in place of the longer word *Photomicrograph* (q.v.). Formerly much used for enlarged drawings of minute objects, as well.

Micromanipulator

An apparatus used in combination with the microscope for carrying on operations on extremely minute objects by means of slow moving, accurately controlled movements of mechanical fingers equipped with the proper tools or instruments.

Micrometer

A device for making minute measurements. See *Filar Micrometer*, *Stage Micrometer*, *Eyepiece Micrometer*, *Cover Glass Micrometer*.

Micron

The 1/1000 of a millimeter, the 1/25,400 of an inch (approx.). Unit of measurement for the size of microscopic objects.

Microphotograph

An extremely minute photograph of

an object of appreciable size, intended to be viewed under a microscope. Often used erroneously, in place of *Photomicrograph* (q.v.).

Microscope

See *Simple Microscope*, *Compound Microscope*, *Ultra Microscope*, *Ultra-Violet Microscope*.

Microtome

An instrument for cutting thin sections of tissue or other material for examination by transmitted light.

Millimeter

The 1/1000 of a meter, practically 1/25 of an inch (approx.). Standard unit of measurement in the mechanics and optics of the microscope.

Minified

The opposite of magnified. Appearing decreased in size.

Mirror

A double sided mirror, one plane and the other concave, required beneath the substage of a microscope for reflecting light from the illuminating source into the condenser and onto the object.

Mirror Arm

The bar carrying the mirror, sometimes fixed in the plane of the optic axis and sometimes pivoted so as to enable the mirror to be decentered with respect to the optic axis.

Monochromatic Light

Light of one particular wavelength or a narrow band of frequencies such that the eye cannot detect an appreciable difference between the colors on each side of the band.

Monochromat Objective

An objective designed to work with a specific wavelength of light, especially for photographic purposes in the Ultra-Violet range.

Monochromator

An illuminating device which separates white light into its spectrum colors

in such a way that any preferred band of color may be chosen for illuminating a microscopic object.

Monocular

Having only one eyepiece. Used to describe a single tube microscope in contradistinction to a binocular form.

N

Negative Lens

See *Lens*, *Negative*.

Newton's Scale

See *Interference Colors*.

Nicol Prism

The original and most common type of calcite prism for producing polarized light. The name "Nicol's" is often used to indicate a polarizer and analyzer, regardless of the actual design of prisms employed. See also *Prism*, *Polarizing*.

Nose Piece

A turret form of *Objective Changer* (q.v.). Made in double, triple and quadruple types.

Numerical Aperture

The term suggested by Abbe for expressing the resolution and light gathering properties of an objective in relation to those of other objectives. It is the value obtained by multiplying the sine of one-half its angular aperture by the refractive index of the medium between the front lens and the cover glass, expressed mathematically as $n \cdot \sin u$.

O

Object (microscopic)

The specimen undergoing microscopic examination. Specifically a prepared specimen permanently mounted on a slide.

Object, Transparent

A transparent object suitably mounted for examination by transmitted light.

Object, Opaque

A non-transparent object, mounted for study by reflected light.

Object, Test

A mounted object intended specifically for testing the performance of an objective.

Objective Changer

A device for quickly changing from one objective to another without the necessity of unscrewing the former and screwing on the latter each time a change is made. See *Nose Piece*.

Object Distance

The distance from an object to the optical center of a lens.

Object Marker

A device for marking or recording the position of a particular point of interest on a slide so that it may be readily found at any time.

Object Plane

The plane normal to the axis of a lens passing through the conjugate focus on which the object is situated.

Objective

The first magnifying element of a compound microscope; that which is nearer the object.

Objective, Achromatic

Lenses in which chromatic aberration has been corrected for two colors, and spherical aberration for one color.

Objective, Apochromatic

The highest type of objective, having chromatic aberration corrected for three colors, spherical aberration for two colors, and the secondary spectrum eliminated.

Objective, Dry

Any type of objective designed to be used with air as the medium between the front lens and the cover glass (or object).

Objective, Fluorite

Sometimes referred to as semi-apochromatic, but actually only a more highly corrected *Achromatic*, made possible by the use of the mineral fluorite in its construction.

Objective, Immersion

Any one of the several types of objectives, designed to use some fluid medium between the front lens and the cover (or object). The fluid may be water, glycerine, cedar oil, sandalwood oil or any other suitable for the particular design of lens. *Homogeneous Immersion Objective* are those which employ a special thickened cedar oil with a refractive index of 1.515, approximating the index of the glass used for the cover and slide.

Oblique Light

Light striking an object on the stage at an angle to the optic axis. It can be either transmitted (i.e., coming through the object) or opaque (from the top) illumination.

Oblique Rays

Rays of light travelling at an appreciable angle to the optic axis.

Ocular

A name used interchangeably with *Eyepiece*. See under the latter for various types.

Oil Immersion Objective

An objective so designed as to require the presence of cedar oil (Refractive Index 1.515) between its front lens and the cover glass of the slide, or the object itself, if no cover be used.

Opaque Illumination

See *Top Illumination*.

Optic Axis

The line passing through the center of a lens and on which the radii of curvatures of the lens surfaces are located.

In the complete microscope, the line passing through the individual optic axes of the entire lens system, eyepiece, objective and condenser.

Optical Axis (Crystallography)

The single axis of optical symmetry in uniaxial crystals, coinciding with the "C" crystallographic axis, or one of the two axes in a Biaxial crystal.

Optical Center

The point on the axis of a lens through which all rays suffering no angular deviation pass. It may lie outside of the lens itself under some conditions.

Optical Tube Length

See *Tube Length*.

Order of Colors

See *Interference Colors*.

Orthoscopic

Having correct appearance, giving a true or proper image. Sometimes used as a trade name to define a lens, especially an eyepiece, possessing superior qualities.

See also *Eyepiece*.

Over-correction.

More than the proper correction, for either spherical or chromatic aberrations, required to bring the aberrant rays to a point focus, so that a condition the reverse of that present in an uncorrected lens, results. The opposite of *under-correction* (q.v.) where the correction is less than the full amount.

P

Parabaloid Condenser

See *Condenser, Dark Field*.

Parallel Rays

See *Rays*.

Parfocal

Adjusted to focus at the same point. Objectives computed optically and mechanically so they can be interchanged without requiring any appre-

cial refocusing are said to be parfocal.

Pedesis

A continuous, vibratory or oscillatory motion of colloidal particles in a fluid medium, due to the presence of an electrostatic charge. Often called *Brownian Movement*.

Periplanatic

See *Eyepiece*.

Petrographic Microscope

A polarizing microscope, especially designed to facilitate making the various types of investigations necessary in the study of rock sections, including conoscopic observations of interference figures.

Photomicrograph

A photograph of an object enlarged only slightly, at most a few diameters. See also *Macrograph*.

Photomicrograph

An enlarged photograph of a microscopic object, taken by means of a microscope. See also *Micrograph*.

Pillar

The vertical portion of the microscope base, extending from the flat horseshoe foot to the inclination joint.

Pinion

See *Rack and Pinion*.

Planimeter Eyepiece

See *Eyepiece*.

Plano-concave

A lens with one surface flat and the other concave.

Plano-convex

A lens with one surface flat and the other convex.

Polarized Light

See *Light, Polarized*.

Polarizer

The polarizing prism used below the stage to provide polarized illumination to the object. See also *Analyzer*.

Polarizing Microscope

A microscope equipped with polarizer and analyzer, producing polarized light for the study of specimens by means of this method of illumination.

Polarizing Object

A mounted object giving polarization effects or brilliant colors under polarized light, especially of beauty for exhibition purposes.

Polarizing Prism

A specially designed compound prism, usually made of calcite (Iceland Spar) which polarizes Light into two components vibrating at right angles to each other and eliminates one of the components. There are many different types of prisms, such as the Nicol, Amici, Ahrens, Abbe, Glan-Thompson, etc.

Polaroid (Trade Name)

A sheet material utilizing the absorption characteristics of Iodo-sulphate of Quinine for producing polarized light.

Positive Lens

See *Lens, Positive*.

Power

A term commonly used interchangeably with magnification, especially in combination with the adjectives, High, Low, Medium.

Principal Focus

See *Focus*.

Principal Plane

One of the two possible planes in a lens system where the projection of the incident and refracted rays would cross. These planes and the planes of the related conjugate foci are known as the four *Cardinal Planes*.

Prism

An optical device of glass or other transparent material utilizing the refraction of light which takes place between two surfaces making an angle

with each other, or the total reflection which occurs beyond the critical angle.

Q

Quarter Wave Plate

A thin disc of Mica cleavage of a thickness such that it causes a retardation of the slow ray one-quarter of a wavelength behind the fast ray after passage through it. See also *Mica Plate*.

Quartz Cell

A shallow cell made of quartz, for use in studying colloidal fluids under dark field. The use of quartz obviates scratching and allows it to be flamed after cleaning.

Quartz Condenser

A substage condenser constructed from quartz instead of glass. Used in connection with ultra-violet light for fluorescences and photography.

Quartz Optics

Objectives, eyepieces, substage condenser, and illuminating system constructed of quartz instead of glass, used for photography in the ultra-violet range.

Quartz Wedge

See *Compensator*.

Quick Screw Substage

A type of substage condenser which is adjusted up and down in the optic axis by means of a multiple thread screw giving a quick action.

R

Rack and Pinion

The toothed rack and its accompanying gear, used for quick movement of the tube or substage condenser, for focusing purposes.

Ramsden Eyepiece (Ocular)

See *Eyepiece*.

Ramsden Circle

See *Eye Point*.

Ray (light)

An imaginary line of light having no perceptible width, an enormous number of which taken together would constitute a beam of light. It is by the assumption of such a ray that the diagramming of the course it takes in travelling through a lens or optical device, is possible. Actually the finest line of light which can be produced, is still a beam of many rays.

Rays, Parallel

Light rays proceeding in a given direction, all of which are parallel to each other, so that they neither meet nor separate.

Rays, Diverging

Light rays proceeding in the same general direction, but spreading apart, (symmetrically) as they advance, hence are always getting farther away from each other.

Rays, Converging

Light rays symmetrically coming closer together as they advance, so that they would finally meet at a point.

Real Image

See *Image*.

Reducing Glass

A concave (negative) lens, which, instead of magnifying an object, reduces or minifies it.

Refraction

The bending which takes place in a ray of light when passing at an angle from one transparent medium into another, more or less dense, i.e., not having the same refractive index; offering more or less resistance to its passage through it.

Refraction, Law of

When light passes at an angle to the perpendicular from one medium to another more dense (i.e. with a higher index), the rays are bent *toward* the perpendicular, and conversely when

passing to one less dense (one with a lower index), they are bent *away from* the perpendicular.

Refractive Index

The ratio of the resistance (or retardation) offered to the passage of light through any given medium, to the resistance (or retardation) of air. The latter is taken as 1.00 (but varies with the temperature), all other substances being higher. Water = 1.33. Ordinary glass about 1.50.

Resolution

The ability of a given objective to show detail in an object, specified in terms of the distance apart two lines (or points) must be (or the number per inch) in order to be revealed as separate lines (or points) and not overlapping so as to appear as one.

Resolution, Limit of

The theoretical maximum which can be expected of an ideally perfect lens of a given aperture in the way of resolution. It is determined by two factors, the numerical aperture of the lens and the wave length of the light employed, the formula being $R = \frac{\lambda}{2N.A.}$

Rheinberg Illumination

A form of illumination for transparent objects, secured by the use of colored discs under the condenser, the center being of one color and the margin another, strongly contrasting with it. The result is an object of one color (supplied by the marginal portion of the disc) on a field having the color of the central portion of the disc.

S**Screen**

- (a) A reflecting surface upon which an image can be thrown for viewing.
- (b) A synonym for a light filter (see *Filter*).

(c) A shield placed so as to cut out any unwanted light or illumination, especially to keep it from the eyes.

Selenite Plate

A special mounted thin disc of Selenite (crystallized gypsum) cleavage for use with a polarizing microscope as a *compensator* (q.v.). Obtainable in the red-violet of the 1st, 2nd, 3rd, and 4th orders, also in various other thicknesses for producing color effects with miscellaneous polarizing objects.

Semi-Apochromatic (objective)

A name often given to objectives in which fluorite has been employed for one of the elements, giving a higher degree of correction than in achromats, although not the equal of apochromats.

Silverman Illuminator

A small tubular lamp formed in a circle, designed to fit by means of a suitable holder around an objective, for the illumination of opaque objects.

Simple Microscope

A lens used directly in front of the eye to give an erect magnified image of an object. Commonly called by various names, such as a magnifier, magnifying glass, reading glass, loup, etc., but distinguished from a compound microscope in that no double magnification takes place.

Slide

(a) A microscopic object, suitably prepared and mounted on a glass slip, for study under the microscope.

(b) The glass slip itself, on which objects can be mounted.

Slip

See *Slide*.

Slit Ultra-Microscope.

The specific name for the *Ultra-microscope* (q.v.) employing an adjustable slide for limiting the extent of the illuminating beam.

Solar Focus

Same as *Principal Focus*.

Spectroscopic Eyepiece

See *Eyepiece*.

Spectrum

Light which has been passed through a prism (or diffracted with a grating) and separated into the various wavelengths of which it is composed. The *Visible Spectrum* shows as a series of colors (e.g., a rainbow) starting with Violet (the shortest wavelength) then Indigo, Blue, Green, Yellow, Orange and Red (the longest wavelength). Rays shorter than the Violet cannot be seen with the eye but are very actinic. They are known as *Ultra-Violet Rays*. Those invisible rays beyond the Red are called *Infra-Red Rays*.

Spider Line Eyepiece

See *Eyepiece*.

Spot Lens

A simple form of dark field condenser, using an ordinary condenser with the central area blocked out by means of black paper or other opaque disc.

Stage

The flat surface (rectangular or circular) of a microscope on which the object is placed for support while being examined.

Stage, Adjustable

A stage, the position of which is not fixed, but can be raised or lowered by rack and pinion, or clamped in various positions in a sliding groove.

Stage, Mechanical

A device, either built in the stage as an integral part of it, or separately attachable to it, for moving an object slowly in both front and back and side to side directions, that every part of the surface may be systematically examined.

Stage, Universal Rotating

A mechanical device for use with petrographic microscopes for rotating a rock section and inclining it at any angle, in any position. Used especially for the study of the optical characteristics of the mineral components of a rock under polarized light.

Stage Micrometer

A fine scale, engraved or photographed on a glass slide, adapted for determining the magnification of the microscope, ascertaining the diameter of the field of view, and calibrating the value of the divisions in the scale of a micrometer eyepiece.

Stand

The complete mechanical part of a microscope, without objectives, eyepieces or condenser.

Stereoscopic (vision) (image)

Yielding images which are three dimensional; that is, possessing depth, instead of a flat field only, as when objects are seen with two eyes. Obtainable in binocular model microscopes, i.e., those having binocular eyepieces, objectives, or both and in models where binocular eyepieces may be substituted for the original monocular one.

Stop

A diaphragm (q.v.) for reducing the aperture of a lens, or for blocking out the central portion.

Sub-Microscopic

An object or particle so small as to be invisible under the microscope, although possibly revealed by the ultra-microscope. Often used interchangeably with *ultra-microscopic* and *amicroscopic*, as covering both. In the light of present day usage of the ultra-microscope, it seems desirable to restrict *ultra-microscopic* to particles seen only by means of the ultra-microscope and *amicroscopic* to those not visible under

any condition. Sub-microscopic would then be the broad term including both.

Substage

The mechanical and optical parts of a microscope beneath the stage, especially those associated with the condenser.

T

Tenth Meter

The decimal part of a meter which is expressed as 1 with 9 ciphers in front of it, also as 10^{-10} m., used for expressing the wavelength of visible light to four places of whole numbers. Also known as the Ångström Unit.

Test Object

Any object, suitably mounted on a slide for study, which can be employed for determining some characteristic of an objective.

Test Plate, Abbe

A special test object, designed by Abbe, consisting of parallel scratched lines across a silvered film, covered with a graduated tapered cover glass, used for testing the performance of lenses, effect of cover glass thickness, etc.

Test Plate, Diatom

A slide on which is mounted a series of picked diatoms, with markings from relatively coarse, graduated to extremely fine, used for testing the performance of objectives.

Test Plate, Ruled Gratings

A test slide having a series of bands, of ruled lines (diamond cut), the lines of each band being ruled successively closer together, used for testing the resolution of objectives. Rulings up to 120,000 lines per inch have been made.

Top Illumination

The illumination of an object, usually (but not necessarily) opaque, by means of light projected on it from

above. The lighting may be either axial, by means of a vertical illuminator, or oblique.

Transparent Illumination

The illumination of an object sufficiently transparent to permit it to be studied by *Transmitted Light*, i.e. light coming from the condenser located beneath the stage. The alternative method is *Opaque or Top Illumination*. (q.v.)

Transmitted Light

See *Transparent Illumination*.

Tube

The portion of the microscope which carries the objective at one end and the eyepiece at the other.

Tube length, Mechanical

The distance from the tube shoulder against which the objective screws, to the far end against which the flange of the eyepiece rests. In modern instruments usually 160 or 170 mms. long (i.e. about $6\frac{1}{2}$ inches) but in older models was figured at 10 inches.

Tube length, Optical

The distance from the rear focal plane of the objective to the front focal plane of the eyepiece. Varies with different objectives, when computed for use with a uniform mechanical tube length, and a parfocal condition.

U

Ultra-Microscope

A name given to the combination of microscope, condensers, slit and luminant by means of which a powerful minute beam of light is projected at right angles across the field of view of a high power objective, illuminating minute (colloidal) particles on an otherwise dark field. Dark field condensers provide an approximation of this condition.

Ultra-Microscopic

Particles so small that they can only be seen by means of the slit ultra-microscope. (See also *Sub-Microscopic*.)

Ultra-Violet (light)

Light waves of shorter length and higher frequency than the violet waves in the visible spectrum, hence invisible to the eye. See also *Spectrum*.

Ultra-Violet Microscope

A complete microscope outfit, including spark illumination from cadmium electrodes, quartz monochromating prisms, microscope with quartz optics and camera, for photography with ultra-violet of $.275\mu$ wavelength.

Under-correction

Only a partial correction for spherical or chromatic aberrations. See also *over-correction*, the opposite condition.

Uniaxial (Crystallography)

Having one optical axis, as in the tetragonal and hexagonal (rhombohedral) systems.

Universal Rotating Stage

See *Stage*.

V

Vernier

A small movable auxiliary scale usually having nine or eleven divisions in the same space as occupied by 10 divisions of a primary scale, for subdividing one division of the latter into ten parts.

Vertical Illuminator

A device located above an objective, for projecting a beam of light, entering at one side, down through the objective, to illuminate an opaque object while it is being viewed by the same objective.

Vibration (of Light)

See *Frequency*.

Virtual Image

See *Image*.

Visible Spectrum

See *Spectrum*.

W

Water immersion objective

An objective designed to work with water as the immersion fluid between the front lens and the object cover glass.

Wave (light)

A term used to describe a single complete cycle in the undulatory movement of light through space, by analogy its motion being likened to the waves occurring on the surface of water, originated by dropping a pebble or other object into it.

See also *Light*.

Wavelength (light)

The distance from the crest of one

wave to the same recurring position in the following wave. In visible light the length of a wave varies from about 4,000 Ångströms (the shortest) to 7,000 Ångströms (the longest). See also *Light*.

Wheel Stop

See *Diaphragm, Dark Field Stop*.

Working Distance

The space between the lowest part of an objective and the cover glass, when the former is focused upon an object, covered with a cover glass of the thickness for which the objective is corrected.

Wright's Universal Eyepiece

See *Eyepiece*.

INDEX

- Abbe, Ernst, 10**
apertometer, 12, 128
comparator, 12
diffraction theory, 133
drawing apparatus, camera lucida, 12, 162
introduction of apochromatic objectives, 12, 40
immersion substage condenser, 10
method of critical illumination, 117
refractometer, 12
substage condenser, 62, 99, 101, 113
test plate, 12, 128, 129
- Aberration, chromatic, 38**
in substage condensers, 113
spherical, 36
in substage condensers, 113
- Aberrations in lenses, 36, 125**
- Accentuating and suppressing contrast, 164**
- Accessories, microscope, 93, 156**
- Achromatic condenser, 62, 101, 114**
objectives, 40
first successful design, 8
- Adjustment, coarse, 43**
fine, 44, 66, 144
- Albumen fixative, Mayer's, 209, 229**
- Alcohol, for mounting purposes, 184**
- Amateurs vs. Professionals, in Microscopy, 152**
- Amici, contributor to microscopy, 7**
introduction of immersion objectives, 9
- Analyzer, 106, 173**
- Analyzing eyepiece, Abbe's, 97**
- Angular aperture, 51**
- Apertometer, Abbe, 12, 128**
- Aperture of objectives, measuring of, 128, 129**
- Aplanatic condensers, 62, 101, 114**
lenses, 37
- Apochromatic objectives, 40**
introduced by Abbe, 12
- Apparatus for special purposes, 156**
- Approach to a microscopical problem, 152**
- Arm, microscope, 44**
- Artifacts, in preparations, 155**
- Aspheric lenses, 37**
- Axial alignment of objective and condenser, 121**
illumination, 115
- Bacon, Roger, mention of uses of lenses, 2**
- Bacteria, slide of, as test object, 138**
- Balsam, Canada, for mounting purposes, 183**
bottle for, 185
- Base, microscope, 44**
- Bausch & Lomb, automatic sliding microtome, 204**
hand microtome, 187
objectives for ultra-violet work, 94
petrographic model, synchronic rotation, 82
research model microscope, 73
reversed type microscope, 77
- Becke test, for refractive index, 165**

- Bell jar, for covering microscopes, 140
- Bertrand lens, for conoscopic vision, 79, 80
- Binocular tube body, interchangeable models, 72
eyepieces, 72, 97, 98
microscopes, Greenough type, 87
- Biological microscopes, 71, 72
problems, 153
- Birefringence, nature of, 174
- Blood, as a test object, 137
smears, making and finishing, 195
- Body tube, microscope, 41
- Bonnani, Philip, early microscopist, 5
- Bottles, specimen, 186
- Box mounts, 215
- Brewster, Sir David, contributor to microscopy, 7
- Brinell microscope, 88
- Bull's-eye condenser, 123, 147
- Cadmium** spark, for use with ultraviolet, 91
- Camera lucida, 162
- Canada balsam, for mounting objects, 183
- Carbolic acid (phenol), for mounting purposes, 185
- Carbol-fuchsin, Ziehl's, 228
- Celloidin, embedding in, 201
- Cells, for mounting thick objects, 181
- Centering adapter (substage) for Royal Soc. thread, 101
- Centering condensers, 101, 121
- Chemical microscopes, 79
- Chemicals for mounting purposes, 183
- Chevalier, contribution to microscopy, 7, 8
microscope of 1851, 9
- Choosing an instrument for specific purposes, 68
- Chrome-acetic fixing agent, 200
- Cleaning of slides and covers, 189
- Clearing of celloidin sections, 208
paraffin sections, 210
- Coma, 40, 125
- Comparison eyepieces, 99, 162
- Compensating eyepieces, 61
- Compound microscope, defined, 34
mechanical design of, 40
- Concave mirror, use of, 110
side reflector, 123
- Concavo-convex lens, 25
- Condenser, Abbe 2 and 3 lens types, 62
aplanatic and achromatic, 62
bull's-eye, 123
centering, value of, 121
dark field (see also dark field), 102
measuring objective aperture with, 129
quartz substage, 103
spectrographic (monochromating), 176
- Condensers, substage, 10, 44, 62, 99
for low powers, 102
supplemental lens for, 111
Zeiss Epi-W, 105, 123, 176
Pancratic, 102, 103, 104
- Conjugate foci, 20
determining position of, 22
- Contrast, accentuating and suppressing, 164
- Convexo-concave lens, 25
- Correction collars on high dry objectives, 56
- Corrections for chromatic aberration, 39
spherical aberration, 37
- Counting chamber, working distance required for, 55
- Counting methods, 159

- Covered and uncovered objects, 55
 Cover glass, cleaning of, 189
 effect of, with oil immersion lenses, 57
 forceps, 183
 gauge, 182
 optical effect of, 56
 proper thickness of, 56, 128
 sizes and thicknesses of, 181
 too thick for working distance, 55, 144
 Critical illumination, 111
 Köhler method, 117
 Crossed prisms, polarizing, 173, 174
 Cross-hair eyepieces, 80, 96
 Cutting of serial sections, 205
- Damage** to lenses in service, 127
- Dark field, substitute for slit ultra-microscope, 90
 condensers, 102, 103
 diaphragms for low power work, 171
 illumination for, 124
 microscopy, 169
 use of, for securing contrast, 165
- Daylight filters for artificial light, 120
 illumination with, 109, 119
- Decalcifying agent, 229
- Decentering of condenser, for oblique illumination, 132
- Defects of lenses, 125
- Delafield's haematoxylin, 227
- Demonstration eyepiece, 98, 161
- Depth of focus, 54, 166
- Determination of magnification, 45
 47
 older objectives, 48
- Diagram, application of dark field principle, 170
 axial illumination with mirror, 115
 chromatic aberration, 38
 critical illumination, 112
 diffused light from window, 118
 effect of cover glass, 56
 foci of lens, 19, 21, 23
 human eye, 26
 image formation, 15, 16, 17, 21, 33
 of slit ultra-microscope, 90
 of compound microscope, 42
 over correction for chromatic aberration, 39
 parallel rays to mirror, 114
 path of rays in compound microscope, 63
 path of rays in cardioid condenser, 101
 path of rays in dry and immersion objectives, 58
 path of rays in vertical illuminator, 84
 relation between light and dark field illumination, 169
 schematic of compound microscope, 35
 spherical aberration, 36
- Diaphragm, substage condenser, 44
- Diatoms, as test objects, 130, 136
 optical sectioning of, 167
- Dichroscopic eyepiece, 97
- Diffused light, unsatisfactory nature of, 119
- Dispersion, defined, 38
- Dissecting microscopes, 108
- Distance of best vision, 27, 29, 32
- Distinguishing characteristics of modern instruments, 65
- Divini, Eustachio, early microscope of, 5
- Double concave lens, 25
 convex lens, 25
 drawing with the microscope, 162
- Draw tube, 43
- Drebell, contribution to early microscopy, 3
- Dry mounting of objects, 213

- Effect** of cover glass thickness on image, 56, 128
- Embedding** methods, 201
- Empty** magnification, 53, 54
- Engravings** on eyepieces, 67
objectives, 66
- Epi-W** condenser, Zeiss, 105, 123, 176
- Equipment** for specialized problems, 175
mounting specimens, 180
- Equivalent** focus, 26, 51
- Erect** images, produced by Porro prisms, 87
- Erecting** eyepieces, 97
- Etching** of polished metal specimens, 224
- Euler**, invention of achromatic lenses, 7
- Extinction** directions (crystal), 174
- Eye**, functioning of, 27
in cross section, 26
magnification accomplished through, 28
- Eyes**, use of both in microscopical work, 149
- Eyepiece**, analyzing, 97
binocular, 97, 98
comparison, 99, 162
compensating, 61
defined, 34
demonstration, 98, 161
dichroscopic, 97
erecting, 97
flat field, wide angle, 95
Homal, 97
Huygenian (negative), 60, 95
micrometer, 96, 97, 158
pointer, 96
Ramsden (positive), 61
relation of barrel length to focal length, 60
spectroscopic, 176
- Eye shield**, 99, 151
- Farrant's** medium, 216, 229
- Filar** micrometer eyepiece, 97, 158
- Filters**, color, for altering contrast, 166
- Fine** adjustment, 44, 66, 144
for condensers, 122
- Finely** divided material, mounting of, 193
- Finishing** of slides, 212
- Fixation** of delicate tissues, 199
- Fixative**, Mayer's albumen, 209, 229
- Fixing** agents, for tissues, 225
- Flat** field oculars, 95
- Fleming's** solution, 200, 227
- Fluid** mounts, 215
- Fluorescence** by ultra-violet light, 165
- Fluorite** objectives, 40
- Focal** plane, 20
point, 20
ratio, (*f* ratio), 51
- Focus**, equivalent, 26, 51
of lens, 20, 51
conjugate, 20
- Focussing** of condenser, 64
of objectives, 142
- Fontana**, early design of microscope, 3
- Foot**, microscope, 44
- Forceps**, cover glass, 183
- Formalin**, as a fixing and preserving agent, 200, 225
- Formation** of image, by a lens, 19, 20
by a pinhole, 15
- Formula** for resolution, 53
fixing and preserving agents, 225
- Galileo**, contribution to the microscope, 2
- Giemsa** stain, 228
- Glass**, ancient origin of, 1
kinds available for lenses, 39

- Glassware, for mounting purposes, 185
- Glycerine, as a mounting medium, 216, 218
- Glycerine jelly, mounting medium, 184, 216, 229
- Greenough binocular microscope, 87
- Ground specimens, preparation of, 218
- Gauge for measuring thickness of slides and covers, 182
- Gum Dammar, mounting medium, 184
- Haematoxylin**, Delafield's, 227
- Hand microtome, 187
- Heidenhain's iron haematoxylin, 228
- Herapathite, polarizing films of, 105
- Herschel, contributor to microscopy, 7
- Homal eyepieces (Zeiss), 97
- Honing of microtome knives, 207
- Hooke, Robert, early English microscopist, 3, 4
microscope of, 6
- Hot stage, 176
petrographic model for use with, 80
- Human blood, as a test object, 137
making smears of, 195
- Huygenian eyepieces, 60
- Hyrax, mounting medium, 184
- Illumination**, 109
critical, 111
daylight, 109
for dark field, 124
lamps for, 119, 120
oblique, 123, 147
- Illuminator, concave side reflector, 123
Silverman, 123
vertical (*see* Vertical illuminator)
- Image formation, with a lens, 19, 33
without a lens, 15
- Image size, relation to object size, 23
- Immersion objectives, 9, 52, 57, 145
- Immersion oil bottle, 145
- Implements, required for mounting, 182
- Inclined single eyepiece holder, 99, 100
binocular eyepieces (*see also* Research models), 149
- Inclination joint, 44, 149
- Index of refraction, 18
- Insects, mounting of, 196
- Insect scales, as test objects, 130, 136
- Interference maxima, Abbe's theory of, 133
- Inversion of image, 15, 21, 143
- Iris diaphragm, condenser, 113, 116
measuring aperture of objective by, 129
reducing aperture of system by, 134
- Iron haematoxylin, Heidenhain's, 228
- Isometric system, 174
- Isotropic (non-polarizing) objects, 174
- Jansens**, originators of the compound microscope, 3
- Jelly, glycerine, 216, 229
- Judging the vintage of an instrument, 65
- Killing**, fixing and preserving of tissues, 199
- Kinds of lenses, 25
- Knife, microtome, sharpening of, 207
- Köhler method of illumination, 117
- Koriska low power adjustable objective, 95

- Laboratory** microscopes, 68
 Lactophenol, 216, 229
 Lamps, for illumination, 119
 Large diameter eyepieces, 65
 Leitz, micromanipulator, 107
 petrographic microscope, CM, 81
 Research microscope, 75
 Ultropak, 105, 123, 176
 Universal microscope, "Panphot," 92
 Lens, defined, 17
 Lenses, early origin of, 1
 kinds of, 25
 see also Objectives, Eyepieces, Condensers
 Lieberkuhn's illuminator for opaque specimens, 7, 123
 solar microscope, 7
 Life cells, 176
 Light, refraction of, 17
 see also Illumination, Ultra-violet
 Limit of resolving power, 53, 131
 without condenser, 134
 of resolution, 54
 of visibility by eye alone, 29
 Lister, development of cemented lenses, 8
 Locating position of conjugate foci, 22
 Long and short mount objectives, 59
 Low power adjustable magnification objectives, 95

Magnification by simple magnifier, 34
 empty, 53
 of compound microscope, 45
 vs. resolution, 168
 Magnified image, 16
 Magnifiers, simple, 31
 Maltwood finder, 161

 Marking objects for future reference, 160
 Material, preparation of, 178
 Mayer's albumen fixative, 209, 229
 Measuring with the microscope, 156, 158
 Mechanical stage, 43, 72, 106, 143, 146
 attachable, 106
 recording object positions with, 160
 measuring with, 156
 Mechanical tube length, 41
 design of objectives, 49
 Medical microscopes, 71, 72
 Metallurgical microscopy, 153, 223
 Metallurgical microscopes, 83
 Metallographic outfits, 83, 86
 Metals, polishing and etching of, 223
Micrographia Illustrata, (Hooke), 5
 Micrography, 163
 Micromanipulator, 107, 176
 Micrometer eyepiece, 60, 61, 96, 157, 158
 Micrometer, stage, 157
 Microscope, ancient origin of, 1, 2
 compound, defined, 34
 simple, 30
 care and manipulation of, 140
 Microscopes, Biological, Medical, Physicians' model, 71, 72
 Brinell, 88
 Chemical and Petrographic models, 79, 81, 82
 Dissecting, 108
 Greenough binocular models, 87
 Metallurgical, 83, 85, 86
 Portable, 86
 Projecting, 88
 Research models, 72, 73, 74, 75, 76
 Reversed arm models, 77, 78
 Slit Ultra-, 88, 89, 90

- Student, Laboratory, School models, 68, 69
 Ultra-violet, 91
 Universal models, 91, 92, 93
 Microspectroscope (eyepiece), 176
 Microtomes, 187, 203, 204, 205
 Minified image, 16
 Mirror and mirror arm, 44
 Mirror, proper use of concave, 110
 Monobromonaphthaline immersion objective, 1.6 N. A., 94
 Monochromatic objectives for ultra-violet, 94
 Monocular tube body, interchangeable type, 72
 Mounted objects for test purposes, 128
 Mounting, equipment, 180
 for study by ultra-violet light, 218
 in Venice turpentine, 217
 media, 132, 183
 of insects, 196
 of microscopical objects, 178, 207
 Mueller's fluid, 227
Negative eyepieces, 60
 lens, 25
 Nct ruling, eyepiece, for counting purposes, 159
 Newton, Sir Isaac, suggestion for achromatic microscope, 6
 Nicol prisms, 104, 173
 Nosepiece, 41, 66, 95
 Numerical aperture, effect on depth of focus, 54
 effect on magnification and resolution, 53
 effect of dry mounts on, 57
 defined, 52
 of substage condensers, 62
 relation of, to working distance, 55
Object marker, diamond, 161
 Maltwood finder, 161
 Object plane, 20
 size, relation to image size, 23
 Objective, defined, 34
 changing devices, 95, 96
 Objectives, achromatic, 40, 94
 as accessory apparatus, 93, 95
 apochromatic, 40, 94
 for dark field chamber, 55
 for ultra-violet photography (B. & L.), 94
 immersion, 9, 52, 57, 145
 mechanical design of, 49
 polarization free, 138
 semi-apochromatic (fluorite), 40
 short mount, for use without cover glass, 57, 94, 148
 testing of, 125
 with correction collars, 56
 Oblique (inclined), extinction, 174
 Oblique illumination, 123
 lighting, for study of diatoms, 132, 134
 Ocular, defined, 34
 see eyepiece
 Oil, immersion, 57, 145
 removing from lenses, 147
 Oiling of condenser, 146
 Opaque illuminators, 105, 123, 176
 objects, apparatus for use with, 104, 123
 examination of, 147
 Optical effect of cover glass, 56
 principles of the microscope, 15
 sectioning, 166
 tube length, 43, 47
 Osmic acid, as killing and fixing agent, 195, 200, 226
 Over correction for chromatic aberration, 39
Paraffin, embedding in, 202
 Parallel extinction, 174

- Parfocal objectives, 47, 143
 Personal equations, in working conditions, 148
 Petrographic microscopes, 79, 81, 82, 175
 slides, making of, 219
 Petroleum oil (Nujol), mountant for U. V. light, 218
 Phenol, for mounting purposes, 185
 Photography, 162
 Photomicrography, 163
 Physician's microscopes, 72
 Plano-concave lens, 25
 Plano-convex lens, 25
 Pleurosigma, as a test object, 134, 135
 Pointer eyepiece, 96, 157
 improvised, 156
 Polarization in objectives, 138
 testing for, 139
 Polarized light, use of, 165, 175
 nature of, 172
 Polarizer, 105, 106, 173
 Polarizing and non-polarizing substances, 174
 Polarizing apparatus, 105, 173, 175
 Polaroid, 175
 Polishing and etching of metals, 223
 Porro prism erecting body, 87
 Portable microscopes, 86
 Positive eyepieces, 61
 lens, 25
 Preparation of ground specimens, 218
 material for examination, 178
 Preserving agents for tissues and organisms, 225
 of fixed tissues, 199
 Principal focus, 20
 Projecting eyepieces, 97
 microscopes, 88
 with the microscope, 162
- Quartz** dark field chamber, objectives for, 55
 lenses, ancient use of, 1
 optics for ultra-violet outfit, 91, 94
 substage condenser, 103
 Questions for preliminary consideration in problems, 154
- Ramsden** eyepieces, 61
 Reagents for mounting slides, 183
 Realgar, mounting medium, 132
 Real image, 25, 32
 Recording positions on slide for future reference, 160
 Refraction of light, 17
 law of, 18
 Refractive index, 18
 determining, by Becke method, 165
 Relation of image size to object size, 23
 Removal of top lens of condenser to increase focal length, 64
 Research microscope models, 72
 Resolution, 51, 53, 131, 134
 limit of, without condenser, 134
 vs. magnification, 168
 Reversed arm type of microscopes, 77
 Rheinberg illumination, 165
 Ringing of slides, 188
 Rock sections, making of, 219
 Royal Society standards, objective and eyepiece, 41
 Ruled gratings, as test objects, 136
- School** microscopes, 68
 Section lifters, 183
 Sectioning methods, 198, 203
 Securing critical illumination, 114
 Selection of an instrument, 68
 Selligie, first successful achromatic objective, 8
 Semi-apochromatic objectives, 40

- Serial sections, 205
 Short mount objectives, 57, 58, 59
 Siedentopf and Zsigmondy, ultra-
 microscope, 88
 Silverman illuminator, 123
 Simple microscopes, 30
 Size (apparent) of object at varying
 distances, 29
 Slides, cleaning of glass, 188
 glass, for mounting, standard
 sizes of, 180
 preparation of permanent
 mounted, 190
 Sliding microtome, 203, 204
 Sliding objective changers (Zeiss),
 96
 Slit ultra-microscope, 88, 89, 90
 Solvents for mounting purposes, 184
 Specialization in microscopy, 152
 Spectacle lens condenser, 62
 Spectroscopic condenser and eye-
 piece, 176
 Spectrum, defined, 38
 Spencer Lens Co., Research model
 microscope, 74
 Reversed type microscope, 78
 Rotary microtome, 205
 Spring clips, 43
 Stage, microscope, 43
 micrometer, 157
 Staining, 192, 207
 Stains, 188
 Standards, Royal Society threads, 41
 Starches, mounting of, 194
 Stereoscopic vision, with Greenough
 binocular, 87
 Storing of mounted slides, 194, 213
 Student's microscopes, 68
 StyraX, mounting medium, 184
 Substage condensers, for low power
 work, 102
 see also Condensers
 Supplemental lens for low power
 illumination, 111
- Suppressing and accentuating con-
 trast, 164
- Table**, characteristics of eyepieces,
 60
 characteristics of objectives, 59
 diatoms for test purposes, 136
 magnification of objectives with
 oculars, 49
 magnifying power of objectives
 (Royal Soc.), 46
- Technique, for special purposes, 156
- Test objects, 130, 137
- Test plate, Abbe, 129
- Testing of objectives, 125
 for polarization, 139
- Thickness of cover glass, ideal, 56
 object, measuring by optical
 means, 158
 of standard grades of cover
 glasses, 181
- Tissues, embedding of, 201, 202
 fixation of, 199, 200
 sectioning of, 198, 203
- Transmitted light, illumination by,
 109
- Tube length, mechanical, 41, 45, 46
- Tube length, optical, 43, 47
 relation of mechanical and opti-
 cal, 47
- Tube, microscope, 41
 length of older and modern, 43,
 46, 65
- Turntable, for ringing mounts, 188
- Typical microscopical problems,
 154
- Ultra-violet light**, for fluorescence,
 165
 mounting technique for, 218
- Ultra-violet outfits, 91
- Ultropak, Leitz, 105, 123, 176
- Uncovered objects (metals), 55
 objectives for use with, 57, 58, 59

- van Leeuwenhoek, Anthony, Early**
 Dutch microscopist, 3, 4
 Replica of his microscope, 4
- Venice Turpentine, mounting medium,** 184, 217
- Vernier, measurements by use of stage,** 156
- Vertical Illuminator, critical illumination with,** 122
 for metallurgical microscopes, 83, 104, 147
 objectives for use with, 58
 path of rays in, 84
- Vibration directions of polarizing prisms,** 174
- Vinylite Resin, as a mountant for U. V. light,** 218
- Virtual image,** 25, 32
 formation by a magnifier, 31
 magnification with, 32
- Water immersion objectives for special purposes,** 94
- Wenham prism binocular microscope (Zentmeyer),** 9, 11
- Whole mounts of small organisms,** 211
- Window, diffused daylight illumination from,** 119
- Wollaston, contributor to microscopy,** 7
- Working conditions,** 148
- Working Distance,** 55, 59
- Workroom microscopes,** 68
- Wratten color filters for microscopic work,** 166
- Xylol, for mounting purposes,** 185
 removing immersion oil with, 147
- Zeiss, centering adapter for substage,** 101
 Epi-W condenser, 105, 123, 176
 Homal eyepieces, 97
 Monobromonaphthaline immersion objective, 94
 Pancratic condenser, 102, 104
 Plankton Searcher objective, 94
 Research Model microscope, 76
 Sliding objective changer, 96
 Universal Microscope "Ultra-phot," 93
- Zenker's fluid,** 227
- Zentmeyer, Continental Model of 1880,** 11
- Ziehl's carbol-fuchsin,** 228
- Zsigmondy, Siedentopf and ultra-microscope,** 88

