

# **DAMAGE BOOK**

Tight Binding Book

Pages are missing

UNIVERSAL  
LIBRARY

**OU\_166567**

UNIVERSAL  
LIBRARY







# MECHANISM

*BY THE SAME AUTHOR*

## **HYDRAULICS**

With Numerous Diagrams. 2 vols. 8vo.  
(Sold separately.)

Vol. I. **Hydraulic Machinery.**

Vol. II. **The Resistance and Propulsion of Ships.**

LONGMANS, GREEN, AND CO.

LONDON, NEW YORK, BOMBAY, CALCUTTA AND MADRAS

# MECHANISM

BY

S. DUNKERLEY

D.Sc., M.INST.C.E., M.INST.M.E.

LATE PROFESSOR OF ENGINEERING AND DIRECTOR OF THE WHITWORTH  
LABORATORY IN THE UNIVERSITY OF MANCHESTER

THIRD EDITION

EDITED BY

ARTHUR MORLEY, M.Sc., M.I.MECH.E.

FORMERLY PROFESSOR OF MECHANICAL ENGINEERING IN UNIVERSITY COLLEGE,  
NOTTINGHAM

*WITH NUMEROUS DIAGRAMS*

NEW IMPRESSION

LONGMANS, GREEN AND CO.

39 PATERNOSTER ROW, LONDON

FOURTH AVENUE & 30TH STREET, NEW YORK

BOMBAY, CALCUTTA, AND MADRAS

1920

*All rights reserved*

## BIBLIOGRAPHICAL NOTE

- First printed* . . . *January, 1905*  
*Second Edition* . . . *June, 1907*  
*Third Edition* . . . *August, 1910*  
*Reprinted* . . . *July, 1912*  
*Reprinted* . . . *April, 1914*  
*Reprinted* . . . *February, 1919*  
*Reprinted* . . . *April, 1920*

## P R E F A C E

THE subject-matter of this book treats of pure mechanism, or the kinematics of machines. It is intended for use in the University and Technical Colleges, and is not meant to be a philosophical treatise on the subject; we have the works of Willis, Rankine, and Reuleaux for that. It is the outcome of experience gained in lecturing on the subject at the Universities of Cambridge and Liverpool, and at the Royal Naval College, Greenwich. The logical treatment of the subject admittedly presents great difficulties, and it was only after anxious thought that the present arrangement was adopted as being, in the author's opinion, the most suitable for the average student.

It was thought desirable to insert an elementary descriptive chapter, which includes an account of various machine tools, and of mechanisms required for special purposes. As far as possible, those illustrations have been selected which, in the writer's opinion, are of most general interest. The remaining chapters include a full discussion of straight-line motions, indicator mechanisms, quick-return motions, couplings, velocity diagrams, approximate solutions to link motions and radial valve gears, acceleration diagrams, toothed wheels, non-circular wheels, cams, and machines for cutting teeth; and a number of numerical examples are added at the end of the book.

I am indebted to many engineering firms—of which acknowledgment is made in the proper place—for kindly supplying me with photographs and descriptions of machines; and also

to the Council of the Institution of Mechanical Engineers, and the Editors of the professional papers, for their kind permission to make use of articles and illustrations appearing in their publications. In dealing with velocity and acceleration diagrams, I have adopted the methods explained by Professor R. H. Smith in his paper published in the *Proceedings of the Royal Society of Edinburgh* for January, 1885.

S. DUNKERLEY.

R. N. COLLEGE, GREENWICH,  
November 25, 1904.

---

## PREFACE TO THE SECOND EDITION

EXCEPT for slight verbal alterations, the first eight chapters remain as in the First Edition.

A ninth chapter has been added, dealing with special subjects. The new matter includes a discussion of freedom and constraint of a point and rigid body, geometrical slides and clamps, Sarrut's parallel motion, the Amsler planimeter, a description of a milling machine, a treatment of worm-gearing, and a new four-piece mechanism by Mr. Bennett, Fellow of Emmanuel College, Cambridge. I am indebted to the Council of the Institution of Mechanical Engineers, and to the Cambridge University Press, for kindly giving permission to use the matter contained in the following articles.

S. DUNKERLEY.

MANCHESTER,  
March 4, 1907.

# CONTENTS

	PAGE
CHAPTER I.	
INTRODUCTORY . . . . .	1-17
CHAPTER II.	
SIMPLE MACHINES AND MACHINE TOOLS, ETC. . . . .	18-110
CHAPTER III.	
MECHANISMS POSSESSING SOME PARTICULAR GEOMETRICAL PROPERTY . . . . .	111-151
CHAPTER IV.	
MECHANISMS CONSISTING OF FOUR LOWER PAIRS . . . . .	152-212
CHAPTER V.	
VELOCITY-RATIO DIAGRAMS—APPROXIMATE SOLU- TIONS TO LINK MOTIONS AND RADIAL VALVE GEARS . . . . .	213-243
CHAPTER VI.	
ACCELERATION DIAGRAMS . . . . .	244-269
CHAPTER VII.	
TOOTHED CIRCULAR WHEELS AND MACHINES FOR CUTTING TEETH . . . . .	270-335
CHAPTER VIII.	
NON-CIRCULAR WHEELS ROTATING ABOUT PARAL- LEL AXES—CAMS . . . . .	336-374
CHAPTER IX.	
SPECIAL KINEMATIC CHAINS . . . . .	375-414
EXAMPLES . . . . .	415-436
INDEX . . . . .	437-448



# MECHANISM

## CHAPTER I.

### *INTRODUCTORY.*

§ 1. **Object of a Machine.**—The subject of mechanism consists of the study of machines. Following Rankine,<sup>1</sup> the use of every machine, of whatever type or size, is to modify motion and force. Some natural source of energy sets into motion a part of the machine usually termed the “driver”; the motion and force imparted to the driver are transmitted through a “train of mechanism” to a part of the machine called the “follower,” at which the useful resistance is overcome; and in the transmission between the driver and follower the force and motion are modified to such an extent, both in magnitude and direction, as to be made available for the particular purpose for which the machine is designed. The train of mechanism may be complex or simple, according to the nature of the machine, and in direct-acting machines may be absent.

§ 2. **Design of a Machine.**—The first step in the design of a machine is to thoroughly grasp the precise nature of the problem that has to be solved, and the principles underlying it. Most frequently the follower has to move in some definite way, depending on the kind of work that has to be done; whilst the motion of the driver depends on the kind of natural source of energy which is available. The follower has to be connected with the driver by a train of mechanism, so that when the driver receives its motion, the follower will have impressed upon it the precise motion required by the nature of the problem. A general outline,

<sup>1</sup> “Machinery and Mill Work.”

or skeleton, of a suitable arrangement would first be sketched without any respect to the detailed proportions or forms of the individual parts; and from that general outline, by means of pure geometry alone, the displacement, velocity, and acceleration of each of the moving parts could generally be accurately determined. Secondly, the force acting on each part would be determined, and each part would be given its proper form and dimensions to withstand these forces; so that the "skeleton" could be clothed with a suitable combination of mechanical parts which would transmit and modify the motion and force according to the necessary requirements. Thirdly, having designed the machine, the dynamical effects of the moving parts could be accurately determined. The first part of this operation belongs to the subject known as the *Kinematics of Machines*; the second, to the *Design of Machine Parts*; and the third, to the *Dynamics of Machines*. The present book deals only with the kinematics of machines.

§ 3. **Parts of a Machine.**—Consider any machine, and see how it is made up; for purposes of illustration, take a very familiar form, namely, the direct-acting machine (Fig. 1). In this, as

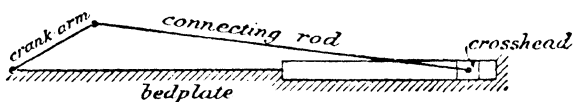

FIG. 1.

in the majority of cases, the various parts—neglecting the slight deformations due to elasticity or change of temperature—are rigid. It is made up of four pieces, namely, the frame or bedplate, the crosshead, the connecting-rod, and the crank shaft, to which is rigidly attached the crank arm and pin. The frame is usually considered as fixed, and the motions of all the other pieces are referred to it; but the frame itself might move, as, for example, in a locomotive or ship. But whether the frame be moving relatively to the earth or not, so long as we imagine ourselves to be carried with the frame, the character of the motions of the other pieces are always the same. The crosshead always

moves to and fro parallel to a plane, the crank pin always moves in a plane perpendicular to the axis, and any other point in the connecting-rod always describes the same path. This perfectly definite motion, which must of necessity be characteristic of all machines, is brought about by the connection of the various pieces with the frame and with each other. Thus the crosshead is guided to and fro in a straight line by contact with straight guides; in order that the crank shaft should continually rotate, it is enclosed within circular bearings which, like the guides, are rigidly attached to the frame; to transmit the motion from the crosshead to the crank pin, each is attached to the connecting-rod. At each end the connecting-rod embraces pins on the crank arm and crosshead respectively, so that as the crosshead moves to and fro, relative angular motion between the connecting-rod and the other two moving pieces is free to take place.

§ 4. **Surface and Line Contact.**— In ordinary machines, considerations of wear and of withstanding steam or water pressure make it desirable that the contact between any two pieces which have relative motion should be a surface contact. In the machine just discussed this condition is satisfied. The crosshead is in contact with the guides over one or more flat surfaces, the crank shaft is in contact with the frame, and the connecting-rod with the crank and crosshead pins, over a cylindrical surface. In the case of the crosshead and guides there is a pure sliding or translation; in the remaining cases there is turning or rotation. We might also have two pieces in which the relative motion is partly translational and partly rotational, but yet in which there is surface contact; as, for example, in the case of the true screw. But with these three exceptions,<sup>1</sup> there is no other type of motion possible in which the motion is governed by the contact of two pieces with each other, and in which, also, the contact is over a surface. It is very important that this point should be thoroughly understood, and to make it quite clear, consider the following illustration. Suppose a point in the block A (Fig. 2) has to describe the plane path denoted by the dotted line by reason of the contact of A with

<sup>1</sup> This is the case for ordinary constructive problems; but a cylinder of any form allows sliding motion, and any surface of rotation allows turning motion.

some other body, B. To obtain the proper shape of B, plot the block in different positions and draw curves to touch the sides of the block; then cut out, in B, a slot of the shape so obtained, so that if A move at all, it must be compelled to move in the dotted path. It is clear that in the general case, where the curvature of the path of A varies from point to point, the block A cannot always be in surface contact with B; if it accurately fit in one position, it will either be loose or jamb in a second position. Continuous surface contact can only be obtained provided the path of A is a circle, in which case, if the fit is exact in one position, it is so in all (Fig. 3). The block need not move

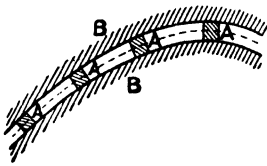

FIG. 2.

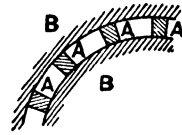

FIG. 3.

always in one direction, but it may move to and fro along an arc; and, moreover, the block may fill the whole or part of the space

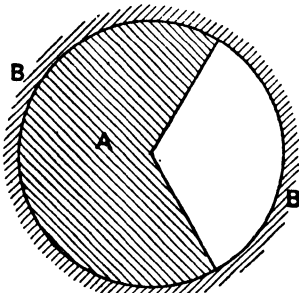

FIG. 4.

within the outer circle (Fig. 4) without altering the character of the motion. Also the radius of the circular path of A may be infinite, and in this case the motion is one of pure translation (Fig. 5), which must of necessity be to and fro. It is perfectly true that, referring to the general case (Fig. 2), A may be in contact with B in every position provided A is a circular pin (Fig. 6), but in that case there is line contact, and

not surface contact, between the two bodies. Theoretically, it gives the required motion, but it has the practical drawbacks already mentioned.

§ 5. Kinematic Pair of Elements. Lower and Higher Pairs.—The form of the slot in B, obtained in the manner just described, may

be defined as the envelope of the successive positions of A, and may always be found by plotting A in different positions. In many cases, the motion of A is so simple that it is unnecessary to draw it in successive positions (as, for example, in Figs. 3 and 5), in order to determine the proper form of B; but in other cases this operation has actually to be performed (for example, in

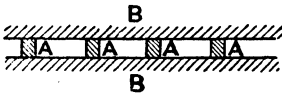

FIG. 5.

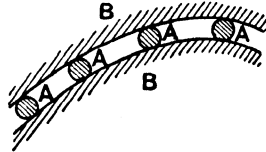

FIG. 6.

toothed wheels), and in all cases it *is* done, either consciously or unconsciously.

A combination of the above type, in which one body is constrained to move in a definite manner by means of an envelope, is termed a *kinematic pair of elements*. If the two pieces or elements are in contact over a surface, the pair is said to be a *lower pair*; if in contact over a line, straight or curved, a *higher pair*.<sup>1</sup> Lower pairs are restricted to the three kinds already pointed out; namely, sliding, turning, or screw pairs. Higher pairs occur in a variety of forms, but one of the most common is toothed wheels.

§ 6. **Kinematic Chain. Mechanism. Machine. Instrument.**—Again, if a number of pairs be successively coupled up so that each element is common to two consecutive pairs, and if, when so coupled up, the motion transmitted is perfectly definite, the combination is termed a *kinematic chain*. If one of the links of that chain be fixed, the chain is termed a *mechanism*; and if some natural source of energy sets into motion an element of that mechanism, we obtain what has been called throughout a *machine*. If the modification of motion is independent of the magnitude and direction of the forces acting, the chain may be said to be *self-closed*.

<sup>1</sup> Not infrequently the term "higher pair" is used to denote a pair in which the connection between the elements is not quite so simple as those already discussed, as, for example, in belt driving.

For example, take the direct-acting engine (Fig. 1). If the crosshead be supplied with side flanges in order to compel it to move parallel to one plane, and if the forces acting are not sufficient to cause permanent deformation in the various elements, the motion of each part is perfectly definite, and is independent of the magnitude or direction of the forces acting; the chain, in other words, is self-closed. The four elements are the frame, crosshead, connecting-rod, and crank shaft; and each of these is common to two pairs, as the following table shows:—

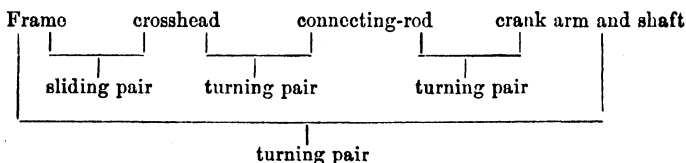

The chain, in fact, consists of one sliding and three turning pairs.

It may happen that in many chains, not less important than self-closed chains, the modification of motion is dependent either on the direction of the forces applied, or else upon frictional resistances. Alteration of the first, or the absence of the second, might either entirely alter the character of the motion or cause no motion to be transmitted. Belts, for example, can withstand a tensile force, or water a compressive force, just as well as a steel rod; and, consequently, so long as the belt always remains in tension, or the water in compression, they may be used as elements in a machine. Again, the onward motion of a locomotive is due entirely to the friction between the driving-wheels and the rails, and if this fail the translational motion ceases.

Again, in defining a machine, no mention is made as to the magnitudes of the motion and force transmitted. Very frequently, when the force or motion transmitted is small, the combination is termed an *instrument*. Thus a chemical balance, a theodolite, or a steam-engine indicator are not usually termed machines; but they differ only in degree, and not in kind, from a 100-ton testing-machine, a giant telescope, or a beam engine, all of which are properly termed machines.

§ 7. **Relative Motions. Point Paths.**—A mechanism has been

derived from a kinematic chain by fixing any one of the links of the latter. By fixing one link, it must not be inferred that that link is absolutely fixed—that is, of course, impossible—or even that it is fixed relative to the earth; the link may be attached to a moving frame, as in a locomotive or ship. To a person standing on the footplate of a locomotive, or in the engine-room of a ship, the motions (say) of the crosshead and crank pin are exactly the same as if the bedplate of the engine were bolted to the earth, and the observer were to stand on the earth. All points of the mechanism and the observer have impressed upon them exactly the same motion, namely, the motion of the locomotive or ship; and impressing the same motion on every point cannot possibly affect the relative motion or paths of the different points.

But the idea of relative motion as applied to kinematic chains

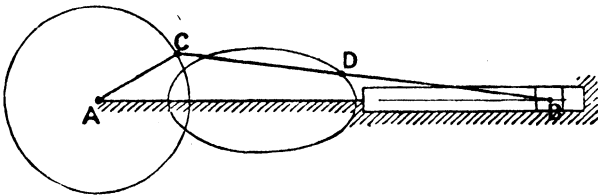

FIG. 7.

has a greater significance than this. Take any self-closed chain in which one of the elements is fixed; say, the direct-acting engine in which the bedplate is fixed. The motions of the different links are independent of the forces acting, and depend entirely upon the geometrical properties of the chain. For example, by plotting the mechanism in different positions, the motions of the different points in, say, the connecting-rod may be traced. The point C, for example (Fig. 7), describes a circle, the point B a straight line, and any other point D in the connecting rod an oval curve; and these are the paths traced out by the different points relative to the frame. But now suppose that, as motion takes place, the path of the point D is required relative to the crank arm AC; that is to say, suppose a sheet of cardboard is pinned to the arm AC, and a pencil attached at D. What curve will the moving pencil at D describe on the moving cardboard attached to the arm? A little

consideration will show that it will be the same in all cases. It will be the same whether the connecting-rod (and therefore the pencil), or whether the arm (and therefore the cardboard), is fixed. If the crank arm is imagined fixed (instead of the bedplate), the connecting-rod must rotate about C as centre, and the bedplate about A as centre; and the pencil D will describe on the cardboard attached to the arm a circle having its centre at C, which will be precisely identical with the curve traced out when both the crank arm and connecting-rod move and the bedplate is fixed. Or again, suppose that the motion of A relative to the connecting-rod CB is required. The path traced out could be obtained by attaching a pencil to A, and a cardboard to the connecting-rod. What curve would the fixed pencil describe on the moving cardboard? Obviously a circle described about C as centre, because if the connecting-rod (that is to say, C) is fixed, A *must* move in a circular path having C as centre.

To emphasize this idea, take the mechanism sketched in Fig. 8, in which two blocks connected by a link of invariable

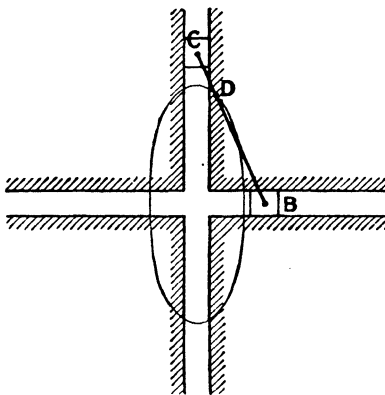

FIG. 8.

length are compelled to slide in two perpendicular slots cut in a board. If the frame of the slots be fixed and the blocks slide in the slots, it is well known (§ 83) that a pencil attached at any point D in the link CB will trace out an ellipse on a sheet of cardboard attached to the frame of the slots. In the same manner, if CB (and therefore the pencil D) be fixed and the frame of the slots move—the two blocks

rotating about B and C respectively—carrying with it the sheet of cardboard, the fixed pencil will describe on the moving cardboard precisely the same curve as before; and if, instead of a pencil at D, a knife or other cutting tool is substituted, it will

cut out an ellipse from the cardboard. This is the principle of the elliptic chuck described in § 99.

It must, therefore, be realized that whichever link of a kinematic chain is fixed, the relative motions of the various links and the relative paths of points in the links are unaltered. By fixing each link in turn, as many mechanisms are obtained as there are links, and the different mechanisms may be used for a variety of different purposes. But it must be remembered that they are the same kinematic chain, and that the modification of motion depends on the chain, and not on the particular mechanism employed. It is the *skeleton* diagram which determines the relative motions, and no matter how machines may differ in constructive or other details, so long as they have the same general outline they may be said to be of the same type.

§ 8. Summary of Foregoing.—The previous remarks on the characteristic features of every machine may be conveniently summarized as follows, where a machine is split up into its most elementary parts:—

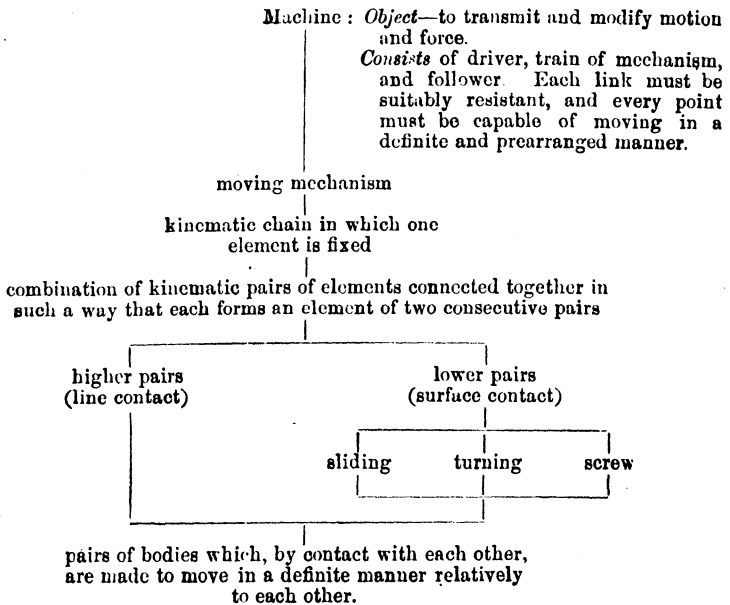

§ 9. Relation between the Number of Pairs and the Number of Elements in a Kinematic Chain.—A kinematic chain is a combination of kinematic pairs of elements, but every combination of kinematic pairs of elements does not form a kinematic chain. For example, in Fig. 9, which consists of four links joined together at the extremities, the motion transmitted through the links is perfectly definite, and is, moreover, independent of the magnitude and direction of the forces acting; consequently the combination forms a closed kinematic chain. But in Fig. 10, which consists of five links joined together at their extremities, the modification of motion which takes place when one link is fixed and a second link is moved is not definite, and it is impossible to predict what it will be; consequently, although Fig. 10 represents a combination of kinematic pairs of elements,

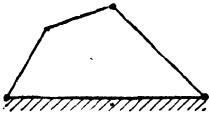

FIG. 9.

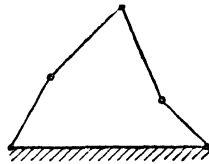

FIG. 10.

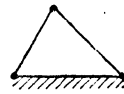

FIG. 11.

it is *not* a kinematic chain, and is quite unsuited to act as a machine. Or again, in Fig. 11, which consists of three links joined together at their extremities, if one link is fixed the remaining two are also fixed; or, in other words, relative motion is impossible. In point of fact, the combination represented by Fig. 11 is a rigid frame. These illustrations show that for a combination of pairs of elements to form a kinematic chain it must just have the proper number of elements, which will depend on the number of pairs. For a given number of joints, less than the proper number of elements makes the motion indefinite while a greater number generally makes the combination a rigid frame.

In simple cases, such as those just discussed, it is easy to tell, by inspection, whether the motion is definite or not; but in more complicated cases it is not easy to trace the motion from link to link, and it is desirable to obtain a test applicable alike to simple and complicated cases. That test consists in finding the proper

number of links required in terms of the number of pairs used. Let us confine our attention to plane motion; that is to say, to motion in which the different bodies move parallel to one plane. Suppose a number of independent pins have to be connected together by a number of rigid links or members so as to form a rigid frame, and suppose, moreover, that not more than two pins are attached to the same link. Clearly, for the first three pins, three links are required; and for each additional pin two additional links are required. For  $n$  pins, therefore,  $2n - 3$  links are required. If more than two pins be attached to any link, then, whatever the number may be, only two of them must be taken when applying the above test; since two points in a rigid link, moving parallel to one plane, are sufficient

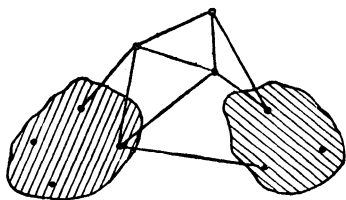

FIG. 12.

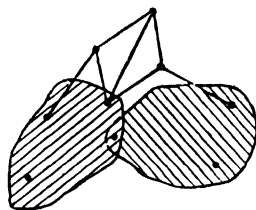

FIG. 13.

to fix the position of that link in the plane. For example, suppose there are two bodies (shown shaded in Fig. 12), one with four and the other with three pins attached, and it is desired to connect the two bodies to, say, three external pins, so as to form a rigid frame. By gradually building up the figure—there are different ways of doing this—it is seen that nine additional links are required, making eleven in all. The number of pins to be taken is seven (not ten), and here  $2n - 3$  is equal to eleven. Moreover, if a pin be common to two links, that pin must not be counted twice, so that only three pins must be counted for the two bodies. Thus, in Fig. 13, where one pin is common to two members and there are three external pins, the external pins may be attached to the two bodies so as to form a rigid frame by seven additional members, making nine in all. The number of pins to be counted is six (three for the two bodies,

and three for the external pins), and here again  $2n - 3$  is equal to nine. Thus, when applying the formula, no element must count more than two pins, and no pin must be counted twice. It does not apply to cases where the number of pins is less than three.

Now in a kinematic chain the combination of elements does not form a rigid frame, but each link has one definite motion relative to any other link. This definite motion may be brought about by removing one of the links in a rigid frame. By so doing, either the whole or part of the links can move in one way relative to each other, and in one way only. If two links be removed, the relative motion of the various links will not be definite—that is to say, when one of the links moves, the motion of *all* the others cannot be predicted. Hence, if  $p$  denote the number of independent pins or pairs of elements, and  $\epsilon$  the minimum number of elements which can form a kinematic chain—

$$\epsilon = 2p - 4;$$

provided that no element counts more than two pairs, that no pair is counted twice over, and that all the links move parallel to one plane. If the number of elements satisfies the above relation, the combination may be called a perfect kinematic chain, and any members in excess of this number may be said to be redundant elements. The effect of one or more redundant members will generally be to lock the mechanism and form a rigid frame. But if in a perfect kinematic chain a point is constrained to move in a certain path, and a further element is added so as to give the point a further (spurious) constraint in the same path, but not to form an additional pair (to be counted), the additional or redundant member will not make the combination a rigid frame. A kinematic chain may have several redundant elements, the number being evidently—

$$\text{actual number of elements} - 2p + 4$$

*i.e.* the excess over the number required for a perfect kinematic chain.

A perfect kinematic chain has the property that a small change

in the dimensions of a single element would not generally lock the mechanism nor change the character of the relative motion of the elements. But if there is a redundant element giving a double constraint to some point, any small change in the dimensions of an element will generally lock the mechanism, and therefore redundant elements are usually avoided (as shown in Figs. 136, 137, and 138).

§ 10. Illustrations of Formula.—To illustrate the formula, consider one or two cases. Thus, take the chain sketched in Fig. 14, which is usually called *Peaucellier's cell* (§ 80). It consists of eight elements pivoted together at their ends. There are six turning pairs, and since no link contains more than two pairs, and no pair must be counted more than once, the value of  $p$  in the formula is six. Hence  $p = 6$ , and  $\epsilon = 8$ , thus satisfying the formula.

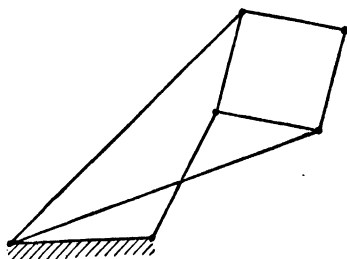

FIG. 14.

If, therefore, any link is fixed, and a second link be set into motion, every other link moves in a perfectly definite manner.

Again, if the chain contain sliding pairs, the sliding pairs must be treated in the same way as turning pairs. Thus in Fig. 1 there are four elements, namely, the frame, crosshead, connecting-rod, and crank shaft; and four pairs, namely, three turning pairs and one sliding pair. No element contains more than two pairs, so that the number of pairs to be taken is four. Hence  $p = 4$  and  $\epsilon = 4$ , thus satisfying the formula.

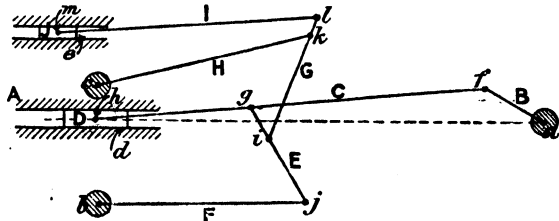

FIG. 15.

As a more complicated illustration, take *Joy's valve gear*, sketched in Fig. 15. Denote each element by a large letter of the alphabet, A denoting the frame. The number of

elements is clearly ten. In estimating the number of pairs, it will be noticed that each of the links A, C, E, and G form the element to more than two pairs, and care must be taken, when estimating the number of pairs, that only two pairs are counted for each of these elements, and that no pair is counted more than once. The pairs are denoted by small letters. The results are best seen when expressed as a tabulated statement, given below.

Name of element.	Pairs common to element.	Number of pairs to be counted for element.
A	<i>a, b, c, d, e</i>	2
B	<del><i>e, f</i></del>	1
C	<del><i>f, g, h</i></del>	1
D	<del><i>f, h</i></del>	0
E	<del><i>g, i, j</i></del>	1
F	<del><i>h, j</i></del>	0
G	<del><i>i, k, l</i></del>	1
H	<del><i>k, o</i></del>	0
I	<del><i>k, m</i></del>	1
J	<del><i>n, o</i></del>	0
Ten elements		Seven pairs

When a "pair" is crossed off, it means that it has been included in a previous element, and the element under which it occurs can only count one additional pair, however many it may be common to. Or, again, if an element, such as D, has both pairs crossed off, that element counts no additional pairs, because two have been already counted. There are different ways of counting, but in all cases the number of elements will be found to be ten, and the effective number of pairs seven (although actually there are thirteen pairs); and thus the relationship  $\epsilon = 2p - 4$  is satisfied. In other words, if A be

fixed and B rotate, every link in the combination will receive a perfectly definite motion, and it may therefore be used as a mechanism.<sup>1</sup>

§ 11. **Case of Higher Pairs.**—In applying the above rule, it will be noticed that, in the cases considered, the pairs are all lower pairs. It does not apply if the number of pairs is less than four; and it shows that kinematic chains in which the motion of every link is parallel to one plane must contain an even number of links.

If a mechanism contain higher pairs, a modification must be made before the formula can be applied. Very frequently, without affecting the motion, a higher pair may be substituted for two lower pairs; thus, for example, in the direct-acting mechanism, the crosshead may be entirely removed, provided the circular pin



FIG. 16.

at the extremity of the rod is allowed to slide between the guides (Fig. 16). With this modification, the mechanism consists of two turning pairs and one higher pair, and although the motion is absolutely definite, the formula does not apply. The formula is only true provided there is only one kind of relative motion, not only for the whole chain, but between any two links in the chain. With the crosshead in place, the connecting-rod can only swing about the crosshead pin, and the crosshead can only slide to and fro in the guides. With the higher pair introduced, the pin is part of the rod, and turns in the guides as well as moving to and fro; or, to express it differently, the pin not only slides in the guides, but rolls in them as well. When a higher pair does occur, it must be imagined replaced by two lower pairs and one element; or, in

<sup>1</sup> Mr. Bennett suggests the following way of expressing the relation between  $p$  and  $e$ . If there are  $a$  elements with three pairs,  $b$  pieces with four,  $c$  with five, etc., then  $p = (a + 2b + 3c \dots)$ . He also suggests the formula  $3e = 2p + 4$ , where  $p$  is got by taking each pair in turn and counting one less than the number of elements hinged therat. Thus in Fig. 15 there are thirteen pairs, hence  $e = 10$ , and subtracting one, leaves nine, the proper number.

other words, when applying the formula, each higher pair must be considered as equivalent to two lower pairs and one additional element.

**§ 12. Minimum Number of Pairs in a Machine. Simple Machines.**

—In considering machines, it is clear that no machine can consist of only one link, but that it must have at least two. A bar of iron, for example, is not in itself a machine; neither is a pivot. But if the bar be rested on the pivot so that the latter acts the part of a fulcrum, the combination may be used as, and will fulfil all the functions of, a machine. A machine, therefore, must consist of at least two links forming one pair. The machines containing only one pair are usually known as the simple machines, and include the *lever, wheel and axle, inclined plane, and screw*. The first two are examples of a turning pair, and the second a sliding pair, and the third a screw pair. In each there is no train of mechanism, and the driver and follower are one and the same piece. They are briefly discussed in Chapter II.

**§ 13. Machines consisting of Two Pairs.**—Kinematic chains having two lower pairs do not exist. Chains having two higher pairs do exist; but generally these are equivalent, kinematically, to four lower pairs. For example, in Fig. 8, the blocks may be dispensed with, and pins, attached to the rod, allowed to slide in the two slots, as in Fig. 16. In such a case, the mechanism will consist of two higher pairs and two elements; but the chain, kinematically, is equivalent to four elements and four lower pairs.

**§ 14. Machines consisting of Three Pairs.**—An example of a machine consisting of three lower pairs is the wedge, which consists of three sliding pairs; another is the hand press, consisting of one turning, one sliding, and one screw pair. By far the most common illustration of a chain having two lower pairs and one higher pair is friction rollers and toothed wheels. Here the two wheels form turning pairs with the frame, and the rollers or teeth, having line contact, constitute a higher pair. A further example of two lower pairs and one higher pair is in belting. These are all fully discussed in Chapter II.

**§ 15. Machines consisting of Four Lower Pairs.**—Examples of chains consisting of four lower pairs (and therefore of four elements)

are exceedingly numerous, and generally occur in link work. They include such familiar mechanisms as the direct-acting engine, the crank and slotted lever, the donkey engine, Watt's parallel motion, toggle joints, Oldham's coupling, Hooke's joint, etc. These, and others, are fully discussed in Chapters III. and IV.

§ 16. **Complex Machines.**—When a mechanism consists of more than four lower pairs, the motions, as a rule, are more complicated than in the foregoing cases. The same general treatment may be extended to all whatever the number of pairs; and the methods are fully discussed in Chapters V. and VI. The general question of higher pairing is discussed in Chapters VII. and VIII.

§ 17. **Plan of the Book.**—As already indicated, the general plan of the book is, roughly, to consider machines according to the number of pairs of elements which they contain. The simple machines, consisting of one pair, are first discussed; then those consisting of three pairs, or a repetition of three pairs,—the latter including those machines in which gearing (belting or toothed wheels) is the important factor,—and under this head a considerable number of machine tools and other appliances are described and illustrated. Following this, the mechanisms consisting of four lower pairs are discussed at length: in the first place, when the mechanisms are used because of some geometrical property; and in the second place, when they are used for power purposes, so that the modification of motion is the important item to consider. The general consideration of mechanisms consisting of any number of lower pairs is next discussed, the determination of velocity and acceleration ratios being explained. Chapters VII. and VIII. are occupied with problems of higher pairing, and include a full discussion of toothed wheels, gear-cutting machines, cams, etc.

## CHAPTER II.

### *SIMPLE MACHINES AND MACHINE TOOLS, ETC.*

WE shall consider, in the present chapter, the simpler kinds of machines.

§ 18. **Machines consisting of One Lower Pair : Lever, Wheel and Axle.**—The lever consists of a link, AB, rotating about a pin, P, the combination forming a turning pair (Fig. 17). When motion takes place, the driving and following points A and B describe circular arcs about the fulcrum P as centre, and the ratio of the

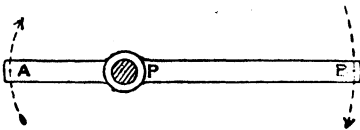

FIG. 17.

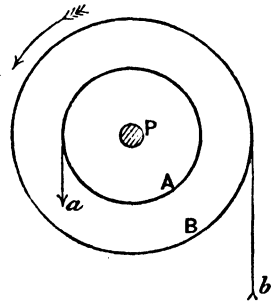

FIG. 18.

velocities of the points A and B is equal to the ratio of the lengths of the arms AP and PB.

In the wheel and axle (Fig. 18), the lever is replaced by two cylindrical pulleys, A and B, keyed to a spindle which rotates in bearings in the frame of the machine. If indefinitely thin belts be wrapped round the pulleys, the velocity ratio of any two points *a* and *b* in them will be equal to the ratio of the radii of the pulleys A and B.

§ 19. **Inclined Plane.**—In the inclined plane we usually require the ratio of the velocity in any given direction to that of the block

along the plane. If the displacement of the block along the plane in a given time is represented by AB (Fig. 19), the vertical displacement will be represented by AC, and the horizontal displacement by CB, and these may be taken to represent the velocities in the three directions. Along any direction whatever, such as AD, the velocity will be represented by AD, D being the foot of the perpendicular from B on the direction AD.

§ 20. **Screw : Single and Multiple Threaded; Right and Left Handed.**

—Imagine the plane in the previous figure to be a thin thread, and let the thread be wrapped round a circular cylinder in such a way that its inclination with a transverse plane is always the same. The curve assumed by the initially straight thread is called a helix (Fig. 20), and the thread may be wrapped round the cylinder

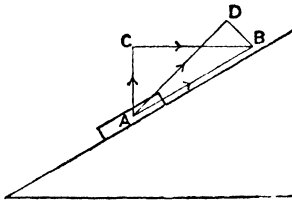

FIG. 19.

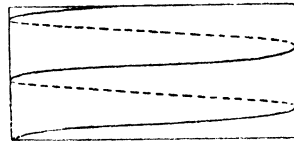

FIG. 20.

any number of times in succession. The *pitch* of the helix is the distance, measured parallel to the axis of the cylinder, between any pair of corresponding points in two successive coils, and, if the thread be correctly wrapped on, will be the same wherever it is measured. Instead of defining the pitch directly as a length, the number of threads or coils in one-inch length of cylinder may be stated; thus eight threads to the inch represent a pitch of one-eighth of an inch. If a small particle be moved along the helix, it will advance a distance equal to the pitch along the axis in the same time that it makes one turn round the cylinder, and any other linear advance will be proportional to the angle turned through measured on a transverse plane.

In practice the thread must be of finite dimensions, and takes the form of a bearing surface as shown in Fig. 21. That surface is such that all cylinders co-axial with the initial cylinder

intersect it in a true helix, the pitch of all the helices being the same. The screw, as it is termed, turns in a bearing or nut, of the same figure, which surrounds the screw and accurately fits it. Either the screw or nut may be fixed—if the former, a rotation of the nut will cause it to move along the screw; if the latter, the screw will advance in the nut; or if the screw simply rotate, but be prevented from advancing, the nut, unless it rotates solid with the screw will advance along the axis of the screw.

When the screw thread is one continuous thread, the screw is said to be *single threaded*. If two screw threads be used side

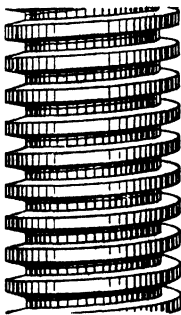

FIG. 21.

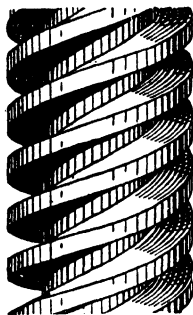

FIG. 22.

by side, at a distance apart equal to half the pitch of either thread, the screw is said to be *double threaded*; if three threads are used, *treble threaded*, and so on. Fig. 21 shows a single-threaded and Fig. 22 a four-threaded screw. Whatever the number of threads, the distance travelled by the nut or screw in each revolution is exactly the same as with a single thread, namely, equal to the pitch of the thread; the primary object of the double or treble threaded screw being to give the screw greater strength in resisting axial force.

Moreover, a screw is said to be right-handed or left-handed according as right-handed or left-handed rotation is required in order to make it advance. This definition is independent of the end from which the screw is viewed. The screws represented in Figs. 21 and 22 are right-handed; in a left-handed screw the inclination of the threads would be in the opposite direction.

A, keyed to the countershaft S by means of the belt which runs horizontally, the shaft turning in bearings in the brackets B, B. The pulley A', which may be slightly less in diameter than A (in order to reduce the tension in the belt when not driving), is not keyed to the countershaft, but rides loosely upon it, so that A' is called the *loose* pulley, and A the *fast* pulley. The sliding piece D, as already described, is provided with a guide or forks, C, and may be moved by pulling the chains F, F attached to the ends of a lever carried by a spindle, E, which can turn in bearings suspended from a bracket, J; and the spindle E also carries an arm, L, which is slotted at the end to receive a pin attached to D. The breadth of the pulley on the main shaft is slightly greater than the sum of the faces of A and A', whilst the belt is slightly less in width than either of the faces A and A'. By pulling F (taking care that the guide C presses on the advancing side of the belt), the motion of rotation of the main shaft may be transmitted to either A or A': if it is transmitted to A, the countershaft rotates; if to A', the countershaft remains at rest, and thus the countershaft may be stopped or started at will without stopping the main shaft.

The motion is transmitted from the countershaft to the machine tools by means of the speed cone G, keyed to the countershaft, which works with a similar speed cone H, keyed to the spindle of the machine tool (in the figure, a lathe); so that by shifting the belt on to the different pairs of pulleys, varying speeds of rotation of H may be obtained. The sliding piece D, with the hanging chains F, is frequently termed the *striking gear*. A self-contained arrangement is shown in the drilling machine illustrated in Fig. 81.

§ 27. **Guide Pulley. Shafts not parallel.**—The lateral stiffness of a belt also allows a motion of rotation to be transmitted between two shafts which are not parallel. As already pointed out, the position which a belt assumes upon a pulley is determined entirely by the position of its advancing side, and so long as the advancing side of the belt lies in, or parallel to, the central plane of the pulley on which it is delivered, the belt will remain on the pulleys. This will be made clear by considering

Fig. 36, which represents an isometric view of two non-parallel, non-intersecting shafts connected by belting. The belt will clearly keep its place on the two pulleys provided the direction of motion is in the direction of the arrows; but if the motion be

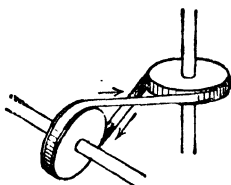

FIG. 36.

reversed, the advancing side of the belt does not then lie in the plane of the pulley on which it is received, and the belt is immediately thrown off both pulleys.

If the shafts to be connected are close together, it is difficult to connect them directly, and in that case *guide pulleys* are used; and by properly placing the guide pulleys, it is possible to make the belt run equally well in both directions. Thus, for example, Fig. 37 shows two shafts, A and B, which are perpendicular to each other and very near together, connected by means of an endless belt passing over two guide pulleys which ride loosely upon the spindle C.<sup>1</sup> Whatever the direction of motion, the central plane

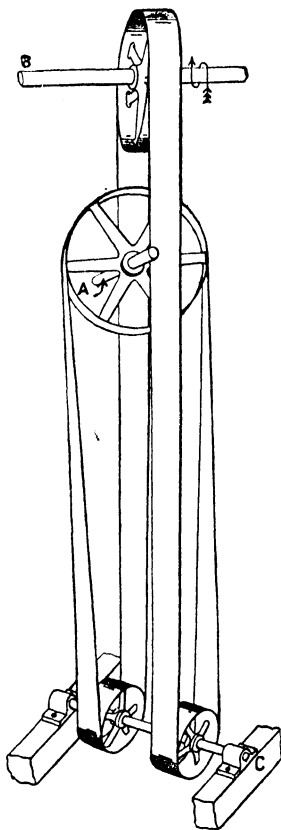

FIG. 37.

of each pulley passes through the point of delivery of the pulley from which the belt is received, and consequently the belt will keep on the pulleys. The guide pulleys do not, of course, affect the velocity ratio between the shafts A and B.

<sup>1</sup> *American Machinist*, March 16, 1901.

§ 28. Tackle. Pulley Blocks.—In belt drives, the object in general is to transmit motion and force between two rotating shafts which turn in fixed bearings. In place of a flat belt, a rope or cord may be used; but since these have very little lateral stiffness, they will not remain, of themselves, on a pulley, and the pulley must be provided with flanges or a groove to keep them on.

The combination of cords and pulleys is used for other purposes than to simply transmit a motion of rotation between two shafts. Not infrequently, one of the axes is capable of moving parallel to itself, and when that is the case, the mechanism is termed a *tackle* or *purchase*. The primary object in such a combination is not to cause the pulleys to rotate, but to cause a relative displacement of the axes on which they rotate; in fact, the rotation of the pulleys is not a necessity, and is only allowed to take place for practical reasons.

A very simple tackle is that shown in Fig. 38, which consists of two cylindrical bodies, A and B, of which B is supported by a fixed bracket, and A is supported by a cord which passes under A and over B. One end of the cord or rope is attached to the fixed point C, and the other end, D, receives a certain displacement downwards; the rope consequently slides over A and B, and A rises through a certain distance. The cylindrical bodies A and B may be replaced by pulleys mounted upon axes, in which case the rope, instead of slipping over the cylindrical bodies,

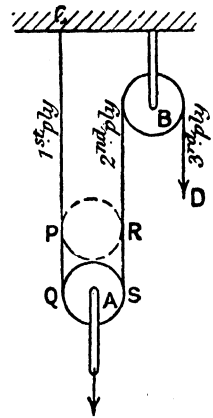

FIG. 38.

will cause the pulleys to rotate; and this modification in construction makes no difference to the vertical motion of A, but it reduces the friction and wear of the moving parts. Such a pulley or sheave mounted upon an axis is called a *pulley block*, and there may be more than one pulley mounted upon a block. Thus, Fig. 39 represents a single pulley block; Fig. 40 a five-sheaved pulley block, because there are five pulleys; and so on.

Referring to Fig. 38, the object is to find the relation

between the displacement of the block A (usually called the *running* or *fly-block*) and the hauling part D of the rope, the different plies of the rope, as they are termed, being supposed parallel. If the block A be raised an inch, every point in the second ply will have to be moved upwards through two inches, in order to make the rope taut again. This is obvious if it be noticed that when the pulley block reaches the dotted position, the length of the cord freed from the pulley is  $(PQ + RS)$ , that is to say, twice the lift of the block. Again, since the axis of B is

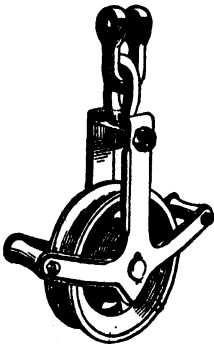

FIG. 39.

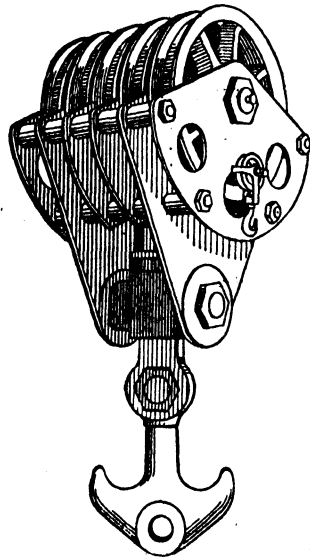

FIG. 40.

fixed, the displacement of every point in the third ply is the same as that in the second, and is therefore equal to twice the displacement of the running block. Thus, the velocity ratio of haul to lift is two, and the arrangement is termed a *twofold* purchase. It will be noticed that the velocity ratio is independent of the size of pulleys used.

By using blocks having more than one sheave, a greater velocity ratio of haul to lift may be obtained. Thus, consider

the arrangement shown in Fig. 41, in which the upper or fixed block is a treble-sheaved block, and the lower or running block a double-sheaved block. The rope would be secured to the eye in the lower block, and would pass successively round the pulleys at the upper and lower blocks. The pulleys are almost invariably of the same size, but whatever the relative sizes, the motion will be precisely the same so long as the different plies of the rope are parallel; and, for clearness in tracing the modification of motion, the pulleys have been drawn of different sizes. If the upward displacement of the running block be denoted by unity, the displacement of a point in the first ply is unity also, and so likewise is the displacement of a point in the second ply, since the rope passes over a pulley with a fixed axis. The displacement of a point in the third ply is made up of two parts. If a point in the second ply were fixed, a point in the third ply would have a displacement of two units, for unit displacement of the lower block; but since a point in the second ply has unit displacement, it follows that a point in the third ply has a displacement of three units. This likewise represents the displacement of a point in the fourth ply. The displacement of a point in the fifth ply is five units, namely two units due to the direct displacement of the block, and three units due to the fact that a point in the fourth ply has a displacement of three units. Thus, the velocity ratio of haul to lift is *five*, and the tackle is said to be a *five-fold purchase*; and so on. In general, the velocity ratio of haul to lift is equal to the number of ropes supporting the movable block.

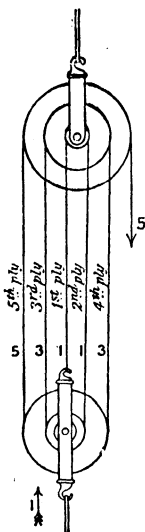

FIG. 41.

It will be noticed that the angular velocity of the different pulleys in the blocks is not the same if they are of the same diameter, and therefore they must rotate separately on the pulley block pins, as shown in Fig. 40.

§ 29. **Differential Windlass. Weston's Pulley Block.**—A further illustration of tackle is the differential windlass. In the ordinary

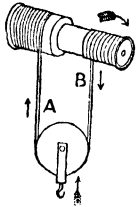

FIG. 42.

wheel and axle (Fig. 18) the velocity ratio of haul to lift is the ratio of the radii of the two cylindrical surfaces, and may therefore be made as large as we please by making the diameter of one of the cylindrical surfaces sufficiently small. This could only be done by making the parts of the machine seriously weak, but a large velocity ratio may be obtained without defect by means of the differential windlass, a sketch of which is shown in Fig. 42. The rope is wound round the two cylinders in opposite directions, and passes underneath a pulley block carrying the weight. As the shaft rotates in a clockwise direction the rope is wound on the large drum and unwound from the small one, and the pulley block rises through a certain distance. To get the rise of the block for each revolution of the drum spindle, let  $R$  and  $r$  be the radii of the large and small drums respectively, so that any point, such as  $A$ , rises through the distance  $2\pi R$ , and a point, such as  $B$ , falls through the distance  $2\pi r$ . Due to the motion of  $A$  alone (the point  $B$  being supposed fixed), the block would rise a distance  $\pi R$ ; due to the motion of  $B$  alone (the point  $A$  being supposed fixed), it would drop through the distance  $\pi r$ . Hence, for each revolution of the drums, the block will rise through the distance  $\pi(R - r)$ ; and this may be made as small as we please, without impairing the strength of the machine, by making the radii of the two drums sufficiently nearly equal. The motion of the block is called a *differential motion*, because its value depends on the difference of two motions, namely, the upward motion of  $A$  and the downward motion of  $B$ . It (as also that of all tackle) is sometimes called an *aggregate motion*.

The objection to the arrangement in Fig. 42 is, that if the block has to have a considerable displacement, the length of rope required is considerable. In fact, for each revolution of the shaft, the length of rope wound on the large drum is  $2\pi R$ , and off the small drum  $2\pi r$ , so that for each revolution we require a length of rope of  $2\pi(R + r)$ . This can be obviated by using an endless rope as shown in Fig. 43, which represents an end view; in which, as before, the block rises through the

distance  $\pi(R - r)$  for each revolution of the drum spindle. The drum spindle is rotated by a force applied at C, and the displacement of the point at which the force is applied is  $2\pi R$ . The velocity ratio of haul to lift is therefore  $\frac{2R}{R - r}$ , which may be made as large as we please by making the radii of the drums sufficiently nearly equal.

As applied in practice, the two drums are replaced by a pulley block, in which two pulleys, A and B (Fig. 44), very nearly equal in size, rotate together; and the endless rope is replaced by a chain which is prevented from slipping by projections which work in the links of the chain. By this mechan-

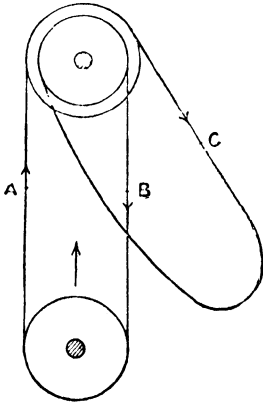

FIG. 43.

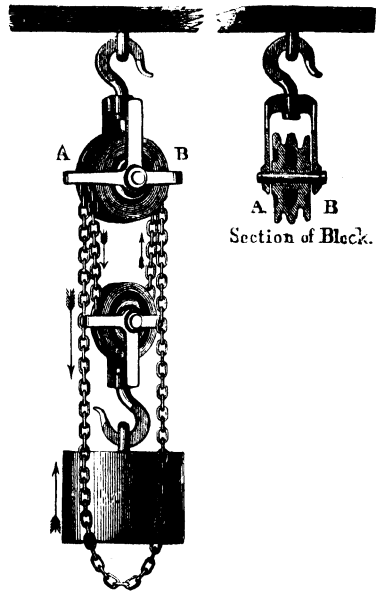

FIG. 44.<sup>1</sup>

ism a very slow motion of the lower block may be obtained, and thus a correspondingly large weight may be raised. It is usually known as *Weston's differential tackle*.

§ 30. **Oblique-acting Tackle.**—In dealing with tackle, it has so far been assumed that the plies of the rope or chain are parallel, and in that case the velocity ratio of haul to lift is constant. If

<sup>1</sup> Reproduced from Goodeve's "Elements of Mechanism."

the plies be inclined to each other, the velocity ratio depends upon the angle of inclination of the plies, and, to a less extent, upon the diameter of the pulleys. Thus, consider the tackle shown in Fig 45, and suppose that the running block A rises in a vertical line from the full to the dotted position. The average velocity of haul to lift is then simply the difference between the lengths of the cords CFE and CGE, divided by the lift AB. This depends upon the inclinations of the ropes, and also, since the arcs of the two pulleys covered by the cord are not the same in the two positions upon the size of the pulleys. But very approximately, if lines AL and AM, be drawn through the centre of the pulley, in the first position, parallel to the directions of the cord; and if, also from the centre of the pulley in the displaced position (which may

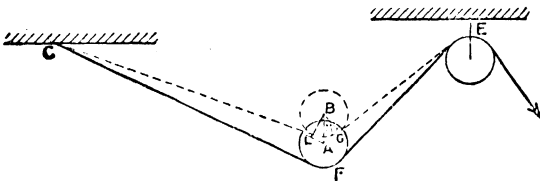

FIG. 45.

be supposed very near to the first) other lines, BL and BM, be drawn perpendicular to the first two lines, then the two portions of the cord are shortened by the amounts AL and AM (approximately), and the actual velocity ratio of haul to lift is  $\frac{(AL + AM)}{AB}$ ; that is to say,  $(\cos \theta_1 + \cos \theta_2)$ , where  $\theta_1$ ,  $\theta_2$  are the angles between the directions of the cord and the line of motion of the block, which in this case is vertical. With parallel cords both  $\theta_1$  and  $\theta_2$  are zero, and the velocity ratio of haul to lift is two, as before.

§ 31. **Friction Rollers and Toothed Wheels. Spur Wheels.** — The object of friction rollers and toothed wheels is, like belting, to transmit a motion of rotation between two axes, and they also are examples of a mechanism consisting of three pairs. Each wheel turns on a pin attached to the frame, and with the frame constitutes a lower pair; the friction rollers or toothed wheels are in contact over a line, and constitute a higher pair.

In the commonest case, the axes of the wheels are parallel, and the wheels are then called *spur wheels*. If friction rollers, or toothless wheels, as they are sometimes termed, be used, the chain is not self-closed, because the rotatory motion can only be transmitted from the one wheel to the second on account of the friction between the two roughened surfaces; and the magnitude of the force that can be so transmitted will depend on the nature of the surfaces and the pressure which acts between them. If slipping take place between the wheels, it is impossible to predict the magnitude of the motion transmitted, and in dealing with toothless wheels it is invariably assumed that there is no slipping.

Consider, then, two circular cylinders, turning about parallel

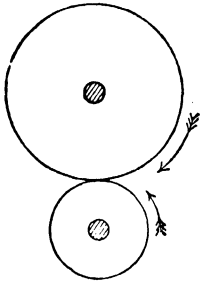

FIG. 46.

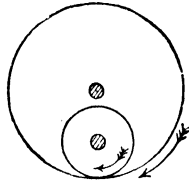

FIG. 47.

axes, which act as friction rollers (Fig. 46). If the action is one of "pure rolling," that is to say, if there is no slipping between the surfaces, it is clear that when motion takes place the circumferential velocity of the two cylinders must be exactly the same; consequently the angular velocities are inversely as the radii of the cylinders. In Fig. 46, the wheels have external contact, and their direction of rotation is opposite to one another; if the wheels have internal contact (Fig. 47), the wheels rotate in the same direction.

§ 32. -Bevel Wheels. Mitre Wheels.—If the axes, instead of being parallel, meet at a point, the motion can be transmitted from one to the other by the rolling contact of two cones whose axes are coincident with the two axes of rotation. Thus, let OA, OB (Fig. 48) be the two axes of rotation, O being their point of

intersection. Imagine cones having these as axes, the line of contact of the cones being OC. Clearly two frusta of these cones might act as driving surfaces. Corresponding circular sections, such as AC and BC, will, barring slipping, have the same circumferential velocity, and consequently the angular velocities of the cones will be inversely as corresponding radii. Expressed differently—

$$\frac{\text{the angular velocity of OA}}{\text{the angular velocity of OB}} = \frac{BC}{AC} = \frac{\sin COB}{\sin AOC}$$

A convenient geometrical construction for finding the angular-velocity ratio is to take any length Oc along the line of contact and to complete the parallelogram Oacb; then—

$$\frac{\text{the angular velocity of OA}}{\text{the angular velocity of OB}} = \frac{Oa}{Ob}$$

When wheels are used to connect two rotating shafts which intersect, they are called *bevel wheels*, and, as in spur wheels, the velocity ratio is constant. Equal bevel wheels whose axes are at right angles are usually termed *mitre wheels*.

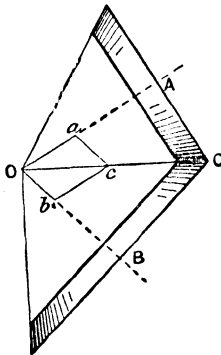

Fig. 48.

§ 33. Rack.—If, in the case of spur wheels, the radius of one of the cylinders is made infinite, the corresponding cylindrical

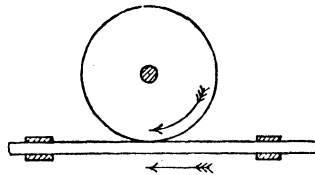

Fig. 49.

surface becomes a plane, and the corresponding rotating cylinder becomes a sliding piece, which is usually termed a *rack*. As the remaining cylinder rotates about its axis, the rack slides between guides (Fig. 49), and, barring slipping, the linear velocity of the rack is equal to the circumferential velocity of the cylinder—that is to say, is equal to the angular velocity of the cylinder multiplied by its radius.

the thread of a screw B—called *the worm*—on the second axis. The screw simply turns in bearings at each end, and is prevented from moving axially by flanges. Fig. 55 shows a single-threaded worm, and clearly one turn of the worm will cause the wheel to advance through one tooth. If the screw on the worm be double-

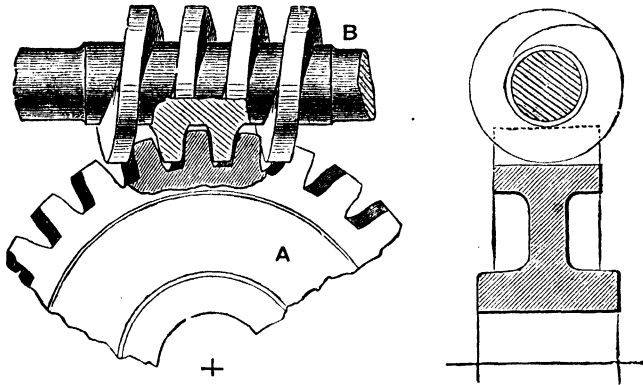

FIG. 55.

threaded, each turn of the worm will cause the wheel to turn through two teeth, since the same thread gears only with alternate teeth of the wheel, and so on. By means of a worm and wheel a very slow motion of the wheel can be obtained.

### § 38. Trains of Wheels. Compound Wheels. Value of Train.

—The pair of wheels so far considered constitute a chain consisting of three pairs. Spur wheels, bevel wheels, and worm wheels are examples of two turning and one higher pair; the wheel and rack is an example of one turning, one sliding, and one higher pair. Very frequently the pair of wheels is repeated over and over again, and we then get a “*train of wheels*.” On each spindle, except the first and the last, there are a pair of wheels which are rigidly attached to each other, and which form what is termed a *compound wheel*.

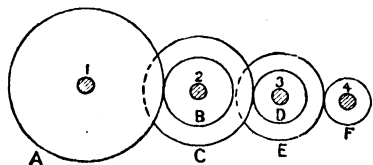

FIG. 56.

The arrangement, as applied to spur wheels, is usually as sketched in Fig. 56, which shows four

spindles. The driver is A, which gears with B, which is compound with C. C in turn gears with D, which is compound with E, which in turn gears with the follower F. In fact, A acts as driver to B, C to D, and E to F. Usually the larger wheel of any compound wheel gears with the smaller wheel of the next. The *value of the train*, that is to say, the number of revolutions which the last wheel makes for each revolution of the first wheel, is obtained as follows: Let the letters A, B, C, D, E, F denote the number of teeth in the various wheels, and let  $N_1, N_2, N_3, N_4$  denote the number of revolutions of the different axes. Then—

$$\frac{N_2}{N_1} = \frac{A}{B}, \quad \frac{N_3}{N_2} = \frac{C}{D}, \quad \frac{N_4}{N_3} = \frac{E}{F}$$

$$\therefore \frac{N_4}{N_1} = \frac{A \cdot C \cdot E}{B \cdot D \cdot F}$$

i.e. the

value of } = \left\{ \frac{\text{continued product of number of teeth in drivers}}{\text{continued product of number of teeth in followers}} \right.

It is clear that, with external gearing, the last and first wheels rotate in the same or opposite direction according as the number of spindles is odd or even. In Fig. 56, for example, the number of spindles is even, and the last wheel rotates in the opposite direction to the first.

In a train of wheels, every pair of wheels which gear together—such as A and B, C and D, or E and F—must have the same pitch; but the wheels forming a compound wheel, such as C and B or D and E, need not of necessity have the same pitch. Very frequently, however, the pitch of every wheel in a train of wheels is the same, so that any pair can work together.

§ 39. **Idle Wheel. Hunting Cog.**—It very frequently happens in

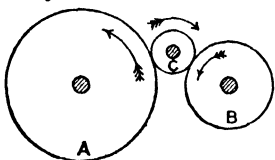

Fig. 57.

gearing that the motion is transmitted from one wheel to a second through a third, as in Fig. 57. The value of the train is simply  $\frac{A}{B}$ , and the object of the

third wheel C is to make A and B rotate in the same instead of in opposite directions, as they would if they

meshed directly with each other. The third wheel is usually termed an *idle* wheel, and it may have, so far as the motion is concerned, any convenient number of teeth. In order, however to preserve the uniformity of the shape of the teeth as much as possible, it is clearly desirable to make any one tooth in, say, A gear as seldom as possible with the same tooth in C; or, what is the same thing, to make one tooth in A gear with as many different teeth in C as possible. To find how many revolutions A has to make before any particular tooth in A gears with the same tooth in C again is a simple matter. If A has half the number of teeth as C, clearly A makes two revolutions and C one revolution; or if A has one-third of the number of teeth as C, A will make three revolutions and C one revolution before the same pair of teeth gear with each other again; and so on. If the number of teeth in one wheel is not an exact multiple of the number of teeth in the second, let A and C be the number of teeth, and  $n_a, n_c$  the least number of turns which A and C have to make before the same pair of teeth mesh together again. Then, since the circumferential distance moved through by each wheel must be the same,  $n_a \cdot A = n_c \cdot C$ ; so that  $n_a \cdot n_c$  must be given the least integral quantities which satisfy this equation. Expressed in words, this equation means that if A and C be divided by their greatest common divisor, the quotient of C will be equal to  $n_a$ , and the quotient of A equal to  $n_c$ . Thus, if  $A = 20, C = 30, n_a \times 20 = n_c \times 30$ , or  $n_a \times 2 = n_c \times 3$ , and therefore  $n_a = 3, n_c = 2$ ; or if  $A = 52$  and  $C = 32, n_a \times 52 = n_c \times 32$ , or  $n_a \times 13 = n_c \times 8$ , therefore  $n_a = 8, n_c = 13$ —that is to say, A would make 8 and C 13 revolutions before the same pair of teeth mesh again. If  $A = 53, C = 32$ , then  $n_a \times 53 = n_c \times 32$ , and therefore  $n_a = 32$  and  $n_c = 53$ , since there is no common divisor. The smaller, therefore, the greatest common divisor, the less seldom do a given pair of teeth mesh with each other. This consideration points to the desirability of making the number of teeth of the idle wheel a prime number. Even when a pair of wheels gear directly, provided no great exactitude in angular velocity ratio is necessary, an additional tooth is sometimes added to the larger wheel to avoid the evil of frequent contact between the same pair of teeth. Thus, for example, by making

the number of teeth in A 53 instead of 52, A has to make 32 revolutions, instead of only 8, before the same teeth gear again, and this without materially altering the angular-velocity ratio. Such an additional tooth is frequently termed a *hunting cog*. It cannot be used in clocks or in screw-cutting lathes, except in the case of an idle wheel, because the value of the train must be exact.

A train of wheels, such as that described, might be used in connection with either bevel wheels, racks, screws, or worms.

#### ILLUSTRATIONS OF MECHANISMS CONSISTING OF GEARING AND BELTING.

Having considered simple cases of gearing, let us consider a few complete machines in which such gearing is the important factor.

§ 40. **Turret.**—The gearing for an electrically driven turret is as follows: The spindle of the motor rotates 400 times a minute, and has a bevel wheel of 20 teeth keyed to it. This gears with a wheel of 24 teeth, on the spindle of which is a single-threaded worm gearing with a wheel of 27 teeth. Compound with this is a spur wheel of 13 teeth and 4-inch pitch, which gears with a circular rack on the turret having a pitch-circle diameter of 17 feet  $2\frac{1}{2}$  inches nearly. Find the time to make one complete revolution of the turret.

The arrangement is as sketched in Fig. 58.<sup>1</sup> The circumference of the pitch circle on the turret is 54 feet very nearly, and consequently, since the pitch is 4 inches, and the number of teeth must be an integer, the number of teeth on the circular rack is 162. For one revolution of the motor, the worm makes  $\frac{20}{24}$  revolutions, the worm wheel (since the worm is single threaded)  $\frac{20}{24 \times 27}$ , and the turret  $\frac{20 \times 13}{24 \times 27 \times 162}$ . Thus for one revolution of the turret, the motor has to make  $\frac{24 \times 27 \times 162}{20 \times 13} = 404$  revolutions. Since the

<sup>1</sup> *Engineering*, January 19, 1900.

motor makes 400 revolutions per minute, the time for the turret to make one revolution is practically one minute.

§ 41. **Capstan Engine.**—The gearing of a capstan engine is arranged as follows: Fixed on the crank shaft A is a double-threaded worm gearing into a worm wheel of 50 teeth; keyed to the worm-wheel shaft is a spur wheel of  $22\frac{1}{4}$  inches diameter pitch circle, and very approximately  $3\frac{1}{2}$ -inch pitch, which drives another wheel of 40 teeth fixed to the same shaft as the holder round which the cable passes. The effective diameter of the cable-holder being 24 inches,

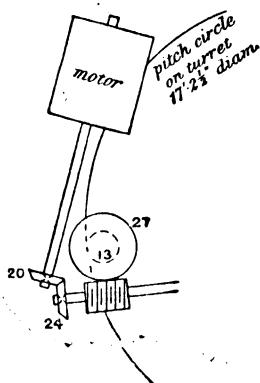

FIG. 58.

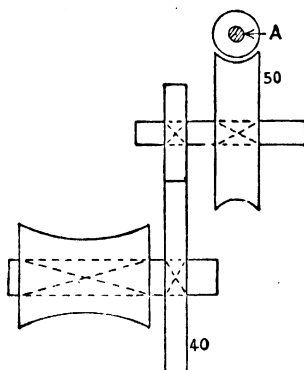

FIG. 59.

find the number of revolutions the engine must make to heave in 90 feet of cable. The arrangement is as sketched in Fig. 59.

The effective circumference of the cable-holder is  $7 \times 2 = 6.28$  feet, and therefore the number of revolutions it has to make is  $90 \div 6.28 = 14.35$ . The number of teeth on the wheel keyed to the worm-wheel spindle is  $\frac{\pi \times 22.25}{3.5} = 20$ . For each revolution

of the engine the worm wheel, since the worm is double-threaded, will make  $\frac{2}{50}$  revolutions, and consequently the cable-holder will make  $\frac{2}{50} \times \frac{20}{40} = \frac{1}{50}$  revolution. Hence to heave in 90 feet of cable, the engine must make  $14.35 \times 50 = 717$  revolutions.

§ 42. **Mechanism for driving the Table of a Planing Machine.**

—The object of a planing machine is to produce plane surfaces. The tool is fixed, whilst the table, to which the work is attached,

reciprocates to and fro in a horizontal direction. The table is driven from the shop shafting, which continuously rotates in one direction, through a train of mechanism; and the problem is to arrange the train of mechanism so that the planing table may either be at rest or in motion in either direction.

A general view of a planing machine is shown in Fig. 60.<sup>1</sup> The table A, to which the work is attached, slides to and fro along

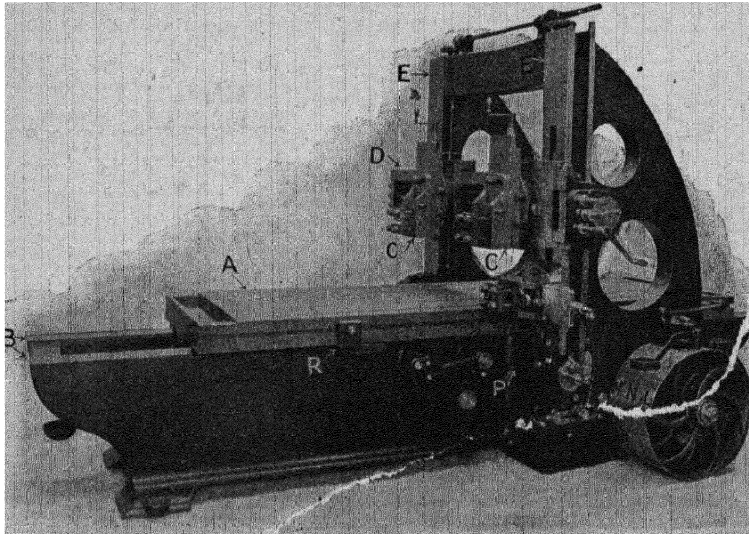

two V-shaped parallel grooves, B, B, formed in the top of the bedplate. The tool is attached to the tool box C, which is carried by the cross-rail D, supported by the columns E, E, so that the position and height of the tool over the table may be readily adjusted. Ordinarily, the tool cuts the metal in one stroke only, namely, as the table moves from left to right; the return stroke, as the table moves from right to left, being an idle stroke. To economize time, the speed of return ought to be greater than the speed of cutting; or, in other words, the train of mechanism ought

<sup>1</sup> By Messrs. Redman and Son, Halifax, Yorks.

to give a "quick return." There are various ways of obtaining the reciprocating motion and quick return of the table; a few of the commoner arrangements may be noticed.

§ 43. Return Motion obtained by Gearing. Shipper Mechanism.

—In machines for light work, the reciprocating motion of the table is frequently brought about by using a screw which passes through a nut attached to the underside of the table, the screw itself turning in bearings in the bedplate, and being prevented

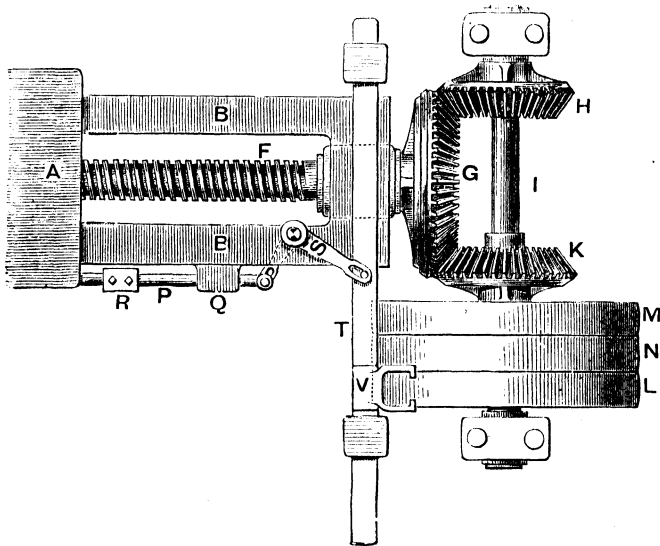

FIG. 61.<sup>1</sup>

from moving axially by flanges. The arrangement, in plan, is shown in Fig. 61, in which A represents the plane table, B, B the parallel V-grooves, and F the screw. At the extremity of F is keyed a bevel wheel, G, which gears with two equal bevel wheels, H and K, at opposite sides of the circumference. The wheel H is keyed to a spindle, I, to which is also keyed a pulley, L; whilst the wheel K is connected with the equal pulley M by a hollow boss which rides loosely over the spindle I. Between the two pulleys L and M is a third pulley, N, which also

<sup>1</sup> Reproduced from Goodeve's "Elements of Mechanism."

rides loosely upon the spindle I, and is not connected in any way with L or M. To the main shaft is keyed a broad-faced pulley—equal in width to L, M, and N combined—which is connected with *one* of the three pulleys by belting, the width of the belt being slightly less than any one of the pulleys, with the result that when the shop shafting rotates, so likewise must the pulley on which the belt happens to lie. If the belt lie on N, no motion will be transmitted to the table; if it lie on L, H will drive G, and therefore, by means of the screw F, cause the table A to move along the bedplate; whilst, if the belt lie on M, K will drive G, and so cause the table to move along the bedplate in the opposite direction to the previous case—the speed of the table being the same in the two directions. Thus, by shifting the belt successively on the three pulleys, the table may be stopped or made to move in either direction whilst the shop shafting continuously rotates in one direction. It will, of course, be noticed that when the belt is on L, the pulley M is driven in the reverse direction by G, and conversely.

The belt is shifted automatically through the motion of the table itself by means of what is termed the *shipper mechanism*. A simple type of shipper mechanism is shown in Fig. 61. Underneath, or at the side of the table, is a rod, P, which can slide between guides, Q, attached to the bedplate; and a movable piece, R, can be clamped to P in any desired position. A bell-cranked lever, S, consisting of two rigid arms, turns about a fixed stud; and the ends of the arms are slotted in order to receive two pins, one pin being attached to the extremity of the rod P, and the other attached to a piece, T, which can slide, in guides, in a direction perpendicular to the screw axis. The sliding plate T carries a fork, V, in which the belt runs, and by means of which the belt is shifted from one pulley to the next. When the table A reaches the stop R, the shipper rod P is pushed along, and, by means of the bell-crank lever S, the sliding plate T is displaced, and the belt transferred from L to the loose pulley N. When the belt is on the loose pulley N it ceases to drive the table, but the table does not immediately stop, because it takes an appreciable time to bring the heavy table and the weight it carries to rest; consequently the belt is further pushed from N to M. When the

belt reaches *M*, the full speed of return is not immediately acquired by the table, because the reciprocating mass has to be gradually set in motion; with the result that at the beginning of each stroke, the belt slips over the pulley, the amount of slipping getting less and less as the speed increases. During the first few moments the energy is, in fact, expended in increasing the speed of the reciprocating mass, and but little is available for cutting; with the result that the stroke must be a little longer than the desired cut. The length of the stroke is adjusted by varying the position of the piece *R* on the rod *P*, a second adjustable piece being acted on by the other end of the table, in order to get reversal at the other end of the stroke. To make the transference of the belt from *L* to *N*, or *N* to *M*, certain, a weight usually falls over as the fork *V* is shifted by the table.

§ 44. **Return Motion obtained by Belting.**—The return motion of the table may also be brought about by using open and crossed belts instead of gearing. In

such a case the pulleys *L* and *M* ride loosely on the screw spindle (Fig. 62, which represents a plan), and the intermediate pulley *N* is keyed to the screw spindle. The broad-face pulley on the main shaft is supplied with two belts—one crossed, and the other open. The sliding piece *T* is

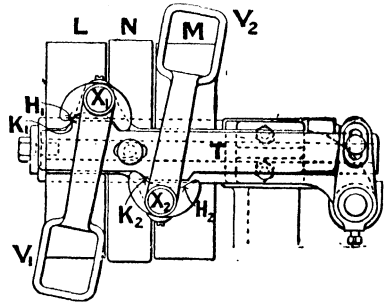

FIG. 62.

actuated from the table as before, and the pair of shippers, *V*<sub>1</sub>, *V*<sub>2</sub>, oscillate about studs, *X*<sub>1</sub>, *X*<sub>2</sub>, attached to the frame of the machine. The open belt runs through *V*<sub>1</sub>, and the crossed belt through *V*<sub>2</sub>, the guides being placed on opposite sides of the sliding piece, so that the guides, in each case, press on the advancing side of the belt. Each shipper is provided, at the pivot end, with a pair of rounded lugs, projections, or cams, *H*<sub>1</sub> and *H*<sub>2</sub>; and the sliding plate *T* is provided, on opposite sides, with the projections *K*<sub>1</sub>, *K*<sub>2</sub>, which act on the inner sides of the cams *H*<sub>1</sub>, *H*<sub>2</sub>. In the position shown, each belt is on its loose pulley, and the machine is at rest;

—the numbers of teeth in the different wheels were as follows:  $H = 22$ ,  $F_1 = 61$ ,  $F_2 = 17$ ,  $K = 17$ ,  $G_1 = 68$ ,  $G_2 = 14$ ; and the pitch of the teeth on the rack was  $1\frac{1}{2}$  inch. Since the wheels  $F_2$  and  $K$  are the same size, the ratio of the return to the cutting speed is  $\frac{F_1}{H}$ , that is,  $\frac{61}{22}$ , which is equal to 2.77. For each revolution of  $L$ , the table during the cutting stroke—since the circumference of the pinion is  $14 \times 1\frac{1}{2} = 21$  inches—will move through  $\frac{22}{61} \times \frac{17}{68} \times 21 = 1.895$  inches = 0.158 feet; and hence if the cutting speed be limited to 20 feet per minute, the pulleys must make  $\frac{20}{0.158} = 127$  revolutions per minute. If the stroke of the table be 4 feet, the time taken to perform the cutting stroke is (neglecting the slipping of the belt at the beginning of the stroke) one-fifth of a minute, and the time for the return stroke is  $\frac{1}{5 \times 2.77} = 0.0722$  minute; so that the time necessary to perform a complete reciprocation of the table is 0.2722 minute, or, in other words, the number of cutting strokes per hour is 220.

The quick-return motion may also be obtained by an arrangement of wheels similar to the back gearing of lathes (§ 47), the fast and loose pulleys being concentric with a spindle corresponding to the headstock spindle.

**§ 46. Quick-return Motion obtained by Belting.**—Very frequently the intermediate gearing is dispensed with and the quick-return obtained by different sized pulleys using an open and crossed belt. One such arrangement is shown in Figs. 65 and 66, which represent a side elevation and plan respectively,<sup>1</sup> and which is similar to the arrangement described in § 44. A bracket,  $X$ , bolted to the bedplate, carries the shipper mechanism. The fast pulleys  $F_1$ ,  $F_2$  are keyed to the screw spindle  $F$ , whilst the pulleys  $L_1$  and  $L_2$  ride loosely over the spindle. The shipper rod  $P$  actuates, through the link  $S$ , the plate  $T$ , which slides on the top of the bracket. The shippers  $V_1$  and  $V_2$ , which guide the open and crossed belts 1 and 2 respectively, are pivoted on lugs,  $X_1$  and  $X_2$ , attached to the frame  $X$ ; and each shipper is provided, at the pivot end, with

<sup>1</sup> *The Mechanical Engineer*, June 9, 1900.

a pair of rounded cams,  $H_1$  and  $H_2$ . The sliding plate  $T$  is provided, on opposite sides, with projections,  $K_1$  and  $K_2$ , which act on the inner sides of the cams  $H_1$  and  $H_2$ , as already explained.

In the position shown, each belt is on its loose pulley, and the machine is at rest; but if the plate  $T$  move to the left, the projection  $K_2$  strikes against the left lug of the cam  $H_2$  of the shipper  $V_2$ , and moves or rocks it to the left sufficiently to bring the belt 2 on the fast pulley  $F_2$ , whilst at the same time the projection  $K_1$  moves opposite to the left lug of the cam  $H_1$ , and effectually locks  $V_1$  in the off position. If the plate  $T$  move to the right, the shipper  $V_1$  shifts the belt 1 on to the fast pulley  $F_1$ , whilst  $V_2$  is locked in the off position.

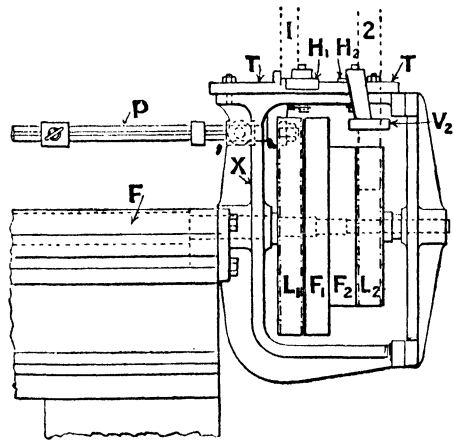

FIG. 65.

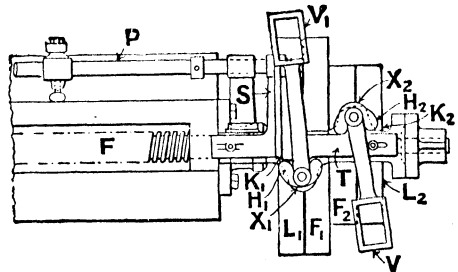

FIG. 66.

§ 47. **Back Gearing of Lathes and Drilling Machines.**—The object

of the back gearing of lathes or drilling machines is to be able to run some spindle of the machine at two or more speeds—the revolutions of the countershaft remaining unaltered—without having to shift the driving belt. A very common arrangement is shown in Fig. 67, and will be at once recognized in the machines illustrated in Figs. 75, 81, 84, and 85. As applied to a lathe,  $C$  is a speed cone, driven from a similar speed cone on the overhead

driving shaft, which rides loosely upon the headstock mandrel B. To the boss of C is attached a spur pinion, D, which meshes with a wheel, E. The wheel E is attached by a hollow sleeve to a

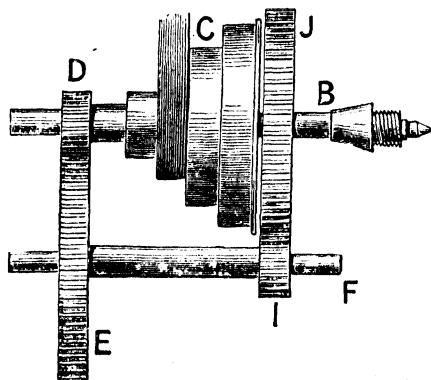

FIG. 67.

pinion I (so that E and I ride loosely over the spindle F), and I meshes with a wheel or main gear, J, keyed to the mandrel B. As arranged in Fig. 67, for each revolution of C the mandrel will make  $\frac{D}{E} \cdot \frac{I}{J}$  revolutions — the letters denoting the number of teeth in the corresponding wheels. To enable the

mandrel to be driven at a quicker speed without shifting the belt, the arrangement is such that J can be rigidly attached to the cone C by means of a bolt,<sup>1</sup> and also the wheels E and I placed out of gear with D and J. The latter movement may be effected in two ways: (1) by sliding the hollow sleeve carrying the wheels along the shaft F, or (2) by attaching the spindle F to the extremities of two short brackets, which turn about pins in the headstock, so that F may be readily swung in and out of gear (Figs. 84 and 85). When out of gear, the revolutions of the mandrel are clearly the same as that of the cone; and thus for each step on the cone there are two speeds of the mandrel. For example, if the number of teeth on J, D, E, and I be 54, 28, 43, and 17 respectively, the back gearing reduces the speed in the proportion  $\frac{28}{43} \times \frac{17}{54} = 0.205$ .

§ 48. **Quick-change Back Gear.**—It will be noticed that in the arrangement just described it is necessary to stop the machine and to use a spanner each time the back gear is put in or out. This necessitates the machine lying idle whilst the change is being made, and in modern tools there is frequently an arrangement by which

<sup>1</sup> For a section of the cone, see Fig. 73, which shows clearly the connecting bolt P.

the change can be made very quickly and without stopping the machine. The most common device is to drive through a friction cone or toothed clutch. One such arrangement is shown in Fig. 68,<sup>1</sup> which represents a longitudinal section through the mandrel.

The speed cone C is provided with a long boss, A, and rides loosely upon the mandrel B. To the boss of C is keyed a pinion, D, which gears with the wheel E, carried by the pin F, attached to the disc plate H, the latter being provided with a long boss, G, which rides loosely over B. The wheel E is compound with a wheel, I, which in turn gears with a wheel, J, keyed to the mandrel B.<sup>2</sup> The arrangement is therefore exactly the same as in the previous case, with the exception that the pin F is carried by a disc instead of by the frame. If H be fixed to the frame, the motion is transmitted from the cone C through D, E, I, and J to the mandrel B, and we thus get the ordinary slow motion. But if H be keyed to the mandrel B, the wheel J and the disc H will rotate as one body, and therefore the train of wheels J, I, E, and D becomes locked, with the result that the motion is directly transmitted from C through the locked gearing to B, and we obtain the quick motion. These two conditions of H—either stationary or rotating—are secured as follows. Upon the boss G of H is feathered<sup>3</sup> a double-faced friction cone or multiple-toothed clutch, K. When K is moved to the left it engages the clutch M, fixed in the frame L of the headstock, and so fixes H. When moved to the right it engages the clutch N, which is keyed to the mandrel B, so that H rotates with the mandrel, and also, on account of the train of wheels being locked, with C. Thus the slow or fast motion may be obtained by simply sliding the clutch to the left or right, and this may readily be done, by means of a forked lever, whilst the machine is in motion. When the clutch K is in the middle position, the cone turns freely, without transmitting

<sup>1</sup> From the *Mechanical Engineer*, September 2, 1899.

<sup>2</sup> The compound gear and the pin are duplicated, in order to obtain a balance amongst the parts.

<sup>3</sup> That is to say, a long key is fitted to the (external) boss G, and a slot or key-way is made in the (internal) boss of K to receive this key. Thus the motion of rotation of H must always be transmitted to K, but in addition, K can slide longitudinally over the boss G.

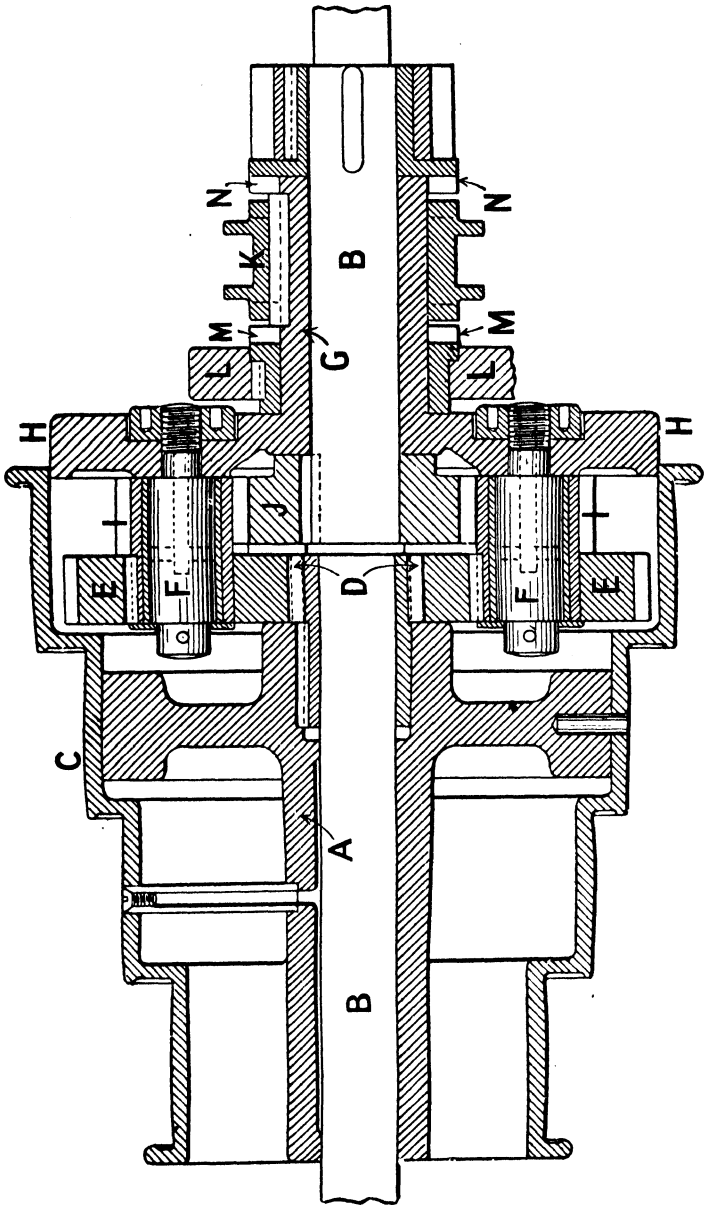

FIG. 68.

motion to the spindle, the train of wheels simply revolving round J, which will be stationary.

In this arrangement it will be noticed the reducing gear is placed inside the speed cone, and would not, therefore, be visible.

§ 49. **Change-speed Gears for Lathes and Motor-cars.**—In screw-cutting lathes, in addition to the back gearing just described, a further change of speed is required between the headstock mandrel and the leading screw. A general view of a lathe is shown in Fig. 75, in which M represents the headstock mandrel, and L the leading screw. The functions of a screw-cutting lathe are described in § 56. Our present object is to see how the motion of rotation is transmitted from M to L, and how, for a given speed of rotation of M, that of L may be readily altered.

§ 50. **Ordinary Change Wheels.**—The gear usually employed is shown on the left of Fig. 75; an end view is shown in Fig. 69.

The motion is transmitted from M to L through the train of wheels A, B, C, and D. The first and last wheels are keyed to the mandrel and leading screw respectively, whilst the intermediate wheels B and C rotate together by being keyed to a loose sleeve, which turns on a pin or stud, supported in a slot in a radial arm attached to L. The radial arm can swing about L, and be clamped

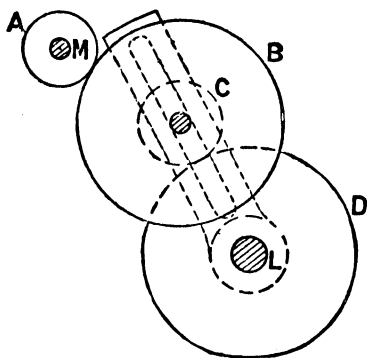

FIG. 69.

in any desired position, whilst the stud or pin carrying B and C can be clamped in any position in the slot. Within limits, any sized wheels, A, B, C, and D, may be made to gear, and also there may be additional pairs of wheels turning on additional studs in the radial arm or arm-plate. If the number of studs be odd, the mandrel and leading screw will rotate in the same direction; if even, in opposite directions. Thus by varying the sizes of the wheels, any speed of rotation of L, in either direction, may be obtained.

§ 51. **Quick Change-feed Motions.**—As in the ordinary back gearing, so in the ordinary *change wheels*, as they are termed, the machine must be stopped each time a change of speed is made, and the time necessary to change the wheels is considerable. In modern machines other change gears replace, or are in addition to, the ordinary change wheels. The object aimed at is to be able to change the velocity ratio of the leading screw and mandrel by a handle movement, which is to be practically instantaneous in action. Almost precisely the same arrangements are used in motor-cars in order to vary the speed of rotation of the wheel axle whilst the engine shaft is running at a constant speed; so that

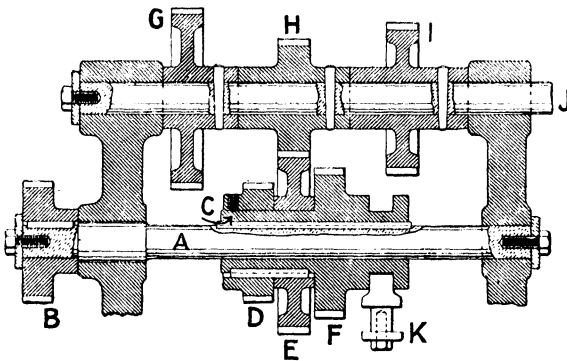

FIG. 70.

although the descriptions will generally refer to lathes, they might, with but slight alteration, be taken to apply equally well to motor-cars.

§ 52. **Sliding Wheels.**—One arrangement is shown in Fig. 70.<sup>1</sup> A spindle, A, receives its motion direct from the headstock mandrel through gearing which meshes with B. The sleeve C is free to slide along A by means of a feather key, and rigidly attached to it are three spur wheels, D, E, and F. These wheels gear respectively with wheels G, H, and I, keyed to a spindle, J, according to the position of the sleeve on A. The spindle J may be the leading screw or the traverse shaft of the lathe (§§ 56 and 57). The

<sup>1</sup> Archdale's change-feed motion; see paper by Mr. John Ashford, *Inst. Mech. Engineers*, part ii., 1901.

position of the sleeve on A is regulated by a handle, K, in front, so that three changes of speed are readily obtained; and the number may be made greater by increasing the number of pairs of wheels. It will be noticed that in this arrangement only one pair of wheels is in gear at a time.

Precisely the same arrangement is used in some motor-cars. In motor-cars driven by a petrol engine, the speed of the engine—unlike those in which the engine is driven by steam—is sensibly constant, whatever the speed of the car. The engine shaft would be in alignment with A, and the connection between the two would be through a friction clutch. On the spindle J would be keyed a spur or bevel wheel, gearing directly with the driving axle of the car, and by throwing the different pairs of wheels in gear, different speeds of rotation of the driving axle may be obtained. Now, to disengage any pair of wheels whilst the full power is being transmitted would require the application of a considerable force, and to engage them again would cause excessive shock. The introduction of the friction clutch obviates these drawbacks. As applied to motor-cars, not only can the sleeve C slide along the shaft A, but the shaft A itself can slide longitudinally in its bearings, and so can be disengaged from the engine shaft. To change the speed, the clutch is first disengaged by sliding A in its bearings, then the sleeve is moved along A until a new pair of wheels are in gear, and finally the clutch is again engaged. When the change is taking place no power is being transmitted, and therefore the wheels D, E, and F are running light, whilst the spindle J still continues to rotate by the onward movement of the car.

§ 53. **Sliding Key.**—An alternative arrangement to the above is to have a sliding key instead of a sliding sleeve. As adapted to lathes, the arrangement is shown in Fig. 71.<sup>1</sup> The short hollow driving spindle A is mounted parallel to the leading screw or the traverse shaft B, and three pairs of wheels, CF, DG, EH, mesh together. The wheels of the spindle A have each six keyways, and they are also counterbored, as shown at I, whilst the remaining

<sup>1</sup> Lang's change-feed motion; see the paper by Mr. Ashford, *Inst. Mech. Engineers*, part ii., 1901.

three wheels are keyed to B. The spindle A is bored and slotted to receive a rod, J, armed with a crosspiece, which acts as a sliding key, K. The handle is used to slide the rod with the key K, its position determining which of the pairs of wheels shall be operative. If the key rest in the counterbored part of the wheels, no motion is transmitted; and having six keyways to each pulley ensures the key readily gearing with any desired wheel. The five

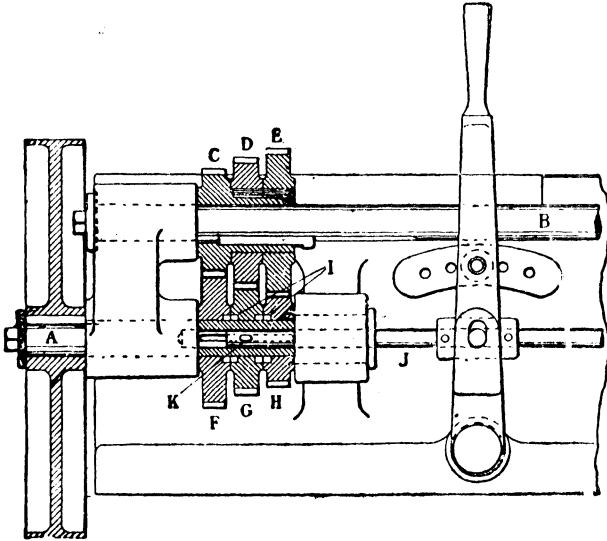

FIG. 71.

pinholes fix the handle in the proper position. In this arrangement it will be noticed that each pair of wheels is always in gear.

§ 54. **Sliding Jaw-clutches.**—A very ingenious speed change gear<sup>1</sup> for motor-car work is illustrated in Fig. 72. As in the gear just described, the gear wheels are always in mesh, but the sliding key is replaced by interlocking jaw-clutches. Moreover, the arrangement is such that before any wheel can be unclutched, the friction clutch through which the motion is transmitted from the engine is released; and, conversely, a new wheel is clutched before the friction clutch again comes into operation. In fact, the operations

<sup>1</sup> By the Langdon-Davies Motor Co., Ltd.

described in § 52 are practically automatic, so that the danger of stripping the teeth by engaging them whilst the full power is being transmitted is removed. As represented in the diagram, the motion is transmitted from the engine shaft J to the spindle A through the clutch T, which can slide along A by means of a feather. The wheels F, G, H ride loosely on A, and, as before, mesh with C, D, E, keyed to the shaft B. The wheels F, G, and H can be connected to the shaft A by the sliding jaw-clutches L, M, and N, which are connected to A by feather keys, or squared necks on the shaft. These clutches are moved along by the forks U, V, and W, which ride quite loosely on the spindle or rod P;

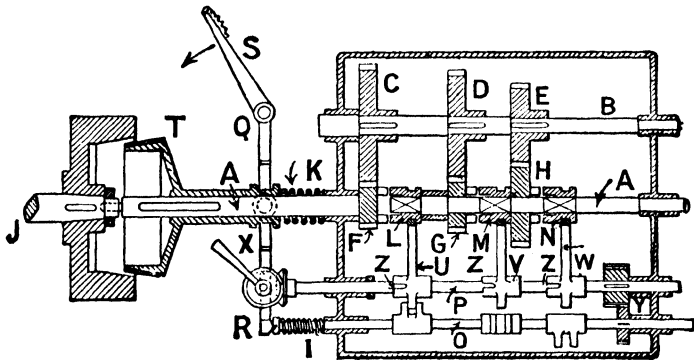

FIG. 72.

and these forks in turn are actuated by corresponding pieces keyed to the spindle O, the lower projections on U, V, and W fitting in grooves on the pieces attached to O. The arrangement is such that U, V, W can never be in gear with the corresponding pieces on O at the same time; but that a rotation of the handle X gives, through the spur wheels Y, sufficient rotation to enable U, V, W to be successively coupled up to O. The friction clutch is released and the jaw-clutches actuated by the depression of the pedal in the following way. The pedal S forms one extremity of a rigid lever, SQR, which turns about a fixed pin, Q. It embraces the sleeve of the clutch T, and presses against the shaft O at its extremity. When the pedal is pressed down, it first releases the

sliding clutch T; a further depression pushes the shaft O sufficiently to the right to unclutch the wheel which happens to be in gear. A rotation of X then allows the selection of another gear wheel; and when the pedal is released, the spring I pushes the shaft O to the left, and through one of the forks U, V, or W operates one of the clutches L, M, N. The spring K then causes the friction clutch to mesh again. Pins and slots Z on the rod P prevent the handle X from being moved except when the pedal is fully depressed, and also prevent any but the selected gear from

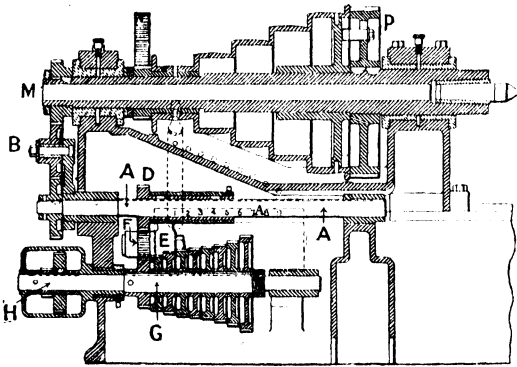

FIG. 73.

being engaged, the handle being definitely locked except when the pedal is depressed.

§ 55. **Tumbler.**—Another change gear,<sup>1</sup> quite different from the previous ones, might be noticed. As applied to a lathe, it is shown in Fig. 73, which represents a section through the headstock. A short shaft, A, is fixed under the centre line of the headstock, and is driven through an idle wheel, B, from a pinion keyed to the lathe mandrel M, so that A rotates in the same direction as M. The shaft A carries a wheel, D, having a long boss, which works on a feather in A, so that D is free to slide along A whilst rotating with it. Encircling the boss of D is the boss of an arm or tumbler, E, carrying a pin, on which rides loosely the pinion F, so that whilst the tumbler is free to swing round the axis of A, the pinion

<sup>1</sup> Lodge and Shipley's change gear.

F is always in gear with D. On the leading screw shaft G are keyed a number of different sized wheels, with any one of which F may be made to gear by moving the wheel D along the shaft A until it is opposite the desired wheel, and then swinging the tumbler so as to cause F to mesh with the wheel on the screw where it is held in position by a spring catch. We thus get as many changes of speed as there are wheels on the leading screw. The tumbler is actuated by a handle and a latch, and an index indicates which pinions are in gear.

The spindle G has been referred to as the leading screw, and in many machines that is the case. But in some cases G is an intermediate shaft which gears with the leading screw, by means of auxiliary gears, in the following way. On G is keyed a compound wheel, H, the number of teeth in one wheel being double that in the other. Two compound twin gears, I and J, each exactly similar to H, rotate independently on a pin, K (see Fig. 74), which is attached to an arm which can swing about the axis of G. The large wheel of H gears with the small wheel of I, and the small wheel of H with the large wheel of J. The spur wheel L is attached to the screw shaft by a feather key, and may be moved along the screw shaft by a handle, so that it may be brought opposite to any of the four wheels of I and J. When opposite any particular wheel, the swinging arm carrying K is raised up until the wheels mesh, and thus for each speed of G we can obtain four speeds of L. The leading screw, it will be noticed, rotates in the same direction as the mandrel.



FIG. 74.

The number of changes of speed, therefore, at which the leading screw can be worked without shifting the belt is considerable. For any pulley on the cone, the backing gearing gives two changes of speed of the mandrel. If there are nine wheels on G, as shown in Fig. 73, there will be eighteen changes of speed of G, and, with the auxiliary gear just described, seventy-two changes of speed of the leading screw for each speed of the mandrel. In the lathe sketched the speed cone has five pulleys, and therefore we may obtain 360 changes for the leading screw for a given speed of the countershaft,

§ 56. **Screw-cutting and Traversing Lathes. Determination of Change Wheels.**—The primary objects of a screw-cutting lathe are (1) to turn the work into the shape of a true cylinder, and (2) to cut upon the cylindrical surface so obtained a screw of any desired pitch. The work is driven directly from the headstock-mandrel through the medium of a catch-plate and carrier, whilst the tool is attached to a saddle which is capable of sliding along the bedplate of the lathe. In self-acting lathes, the sliding motion of the saddle is effected from a traverse shaft, which is usually placed along the back of the lathe, and which is driven from the headstock mandrel either through a train of wheels or by belting. In screw-cutting lathes, the motion of the saddle is obtained by a nut on the saddle gearing with the leading screw of the lathe, the leading screw being made to rotate by being geared to the mandrel. In addition to these two motions, the saddle can be run along the bed by hand, a pinion keyed to the hand spindle (and which is carried by the slide itself) gearing with a rack attached to the underside of the lathe bed. The object is to see how the more important of these motions are brought about, and also how the motions so transmitted may be modified.

The general view of a screw-cutting lathe is shown in Fig. 75.<sup>1</sup> In that figure M is the mandrel, S the saddle, and L the leading screw. The motion of rotation of M is transmitted through the train of wheels (§ 50) on the left of the headstock to the screw L. The saddle and the leading screw are connected or disconnected by two half-nuts, which can be brought together or separated by turning a handle working in the apron of the saddle. To the spindle of the handle E, also carried by the apron, is keyed a pinion, which meshes with the rack F, so that when the half-nuts are released the saddle can be run to and fro along the bed by turning the handle E; and when the half-nuts are in gear the motion of the saddle derived from the leading screw simply causes the handle E to rotate.

The ordinary gearing, or change wheels, which connect the mandrel M with the leading screw L have been already described in § 50. If the half-nuts engage with the leading screw, and if the

<sup>1</sup> By Messrs. Redman and Son, Halifax, Yorks.

gearing is such that M and L make the same number of turns per minute in the same direction, the screw cut on the work will

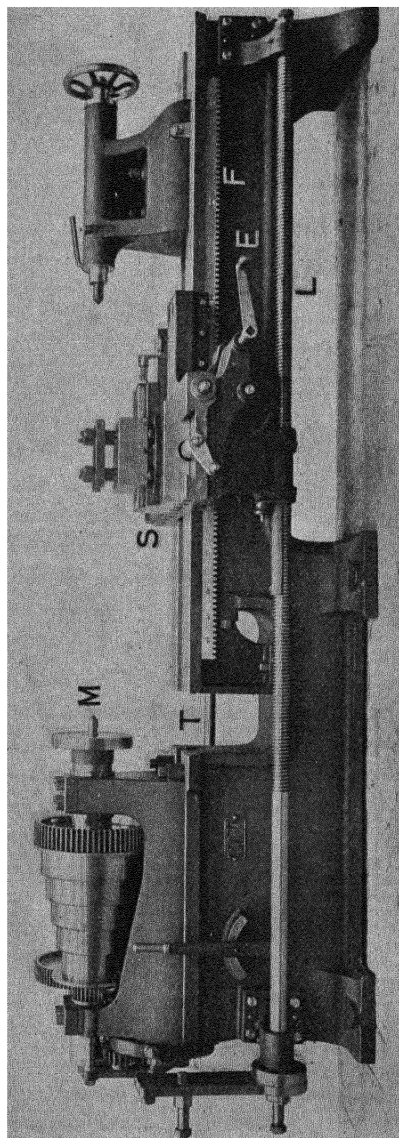

FIG. 75.

clearly be an exact imitation of that on the leading screw, that is to say, it will have the same pitch as the leading screw; or if the leading screw revolve at half the speed of the mandrel, the screw cut on the work will have half the pitch of the leading screw, and so on. If the mandrel and leading screw rotate in contrary directions, the screw cut out will be left-handed if the leading screw is right-handed, and conversely. The leading screw is almost invariably right-handed. The problem is, knowing the pitch of the leading screw and the pitch of the screw required, to arrange the change wheels accordingly.<sup>1</sup> Take one or two numerical illustrations. Suppose that the leading screw is right-handed, and has four threads to the inch, the smallest wheel of the set having 20 and the largest 120 teeth.

(i.) *Required to cut a right-handed screw of 24 threads to the inch.*—In this case the pitch of the leading screw is six times the

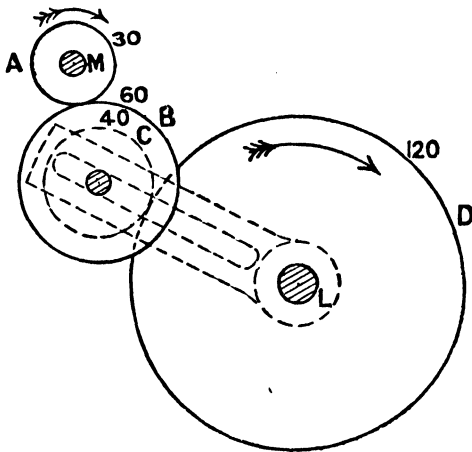

FIG. 76.

required pitch, and therefore for each revolution of the mandrel the leading screw must only rotate through one-sixth of a revolution. The value of the train is therefore one-sixth. Moreover, since both screws are right-handed, the mandrel and leading screw must rotate in the same direction, and therefore there must be an odd number of axes. If four wheels

are used (referring to Fig. 69)—

$$\frac{A}{B} \cdot \frac{C}{D} = \frac{1}{6}$$

<sup>1</sup> A set of change wheels—usually eighteen or twenty-four—is provided with every lathe,

which is satisfied by making  $A = 30$ ,  $B = 60$ ,  $C = 40$ , and  $D = 120$ , as shown in Fig. 76.

(ii.) *Required to cut out a right-handed screw of half-inch pitch.*

—In this case the mandrel and leading screw rotate in the same direction (and therefore

there must be an odd number of axes), and the leading screw must rotate twice as fast as the mandrel. The arrangement in Fig. 77 might be used, in which the idle wheel may have any number of teeth (see § 39); or, using smaller wheels, an alternative arrangement is shown in Fig. 78, the two idle wheels

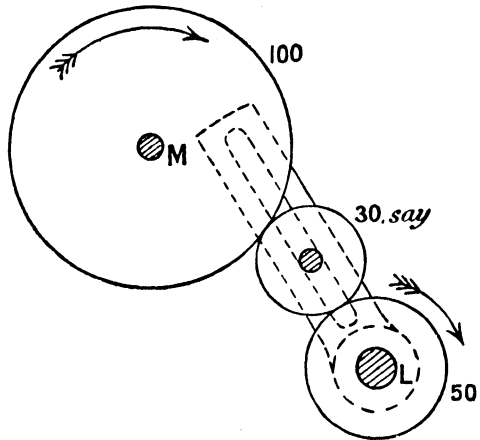

FIG. 77.

being used in order to make the number of axes odd and to span the distance between the mandrel and leading screw.

(iii.) *Required to cut out a left-handed screw having 8 threads to the inch.* In this case

the directions of rotation of the mandrel and leading screw are opposite, and therefore there must be an even number of axes; and the leading screw must rotate at half the speed of the mandrel. The simplest arrangement is to have two wheels, one double the other, but in general no two wheels

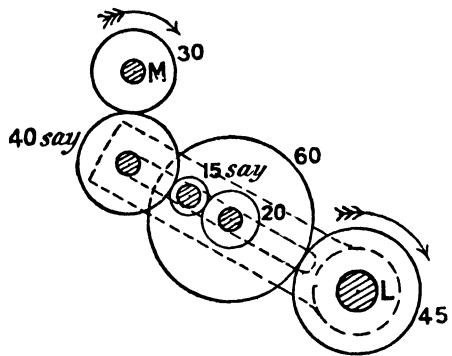

FIG. 78.

having this ratio of teeth will just span the distance between the mandrel and screw, and the arrangement in Fig. 79 may

be used. Two idle wheels are necessary to give an even number of axes.

By proceeding in the way described, a convenient train of

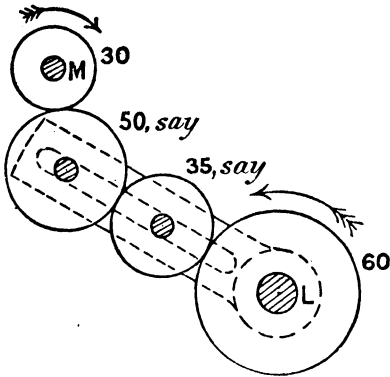

FIG. 79.

wheels may be readily obtained which will enable any desired pitch to be cut. Usually, with every lathe, a table is supplied which gives, by inspection, the proper number of teeth in each wheel, in order to cut any desired pitch; yet, notwithstanding this, the time necessary to change the wheels is considerable, and in modern machines other change gears replace, or are in addition to, the ordinary change wheels.

The alternative arrangements have been fully described in §§ 51 to 55, and a further discussion is unnecessary.

§ 57. *Traversing*.—In screw-cutting lathes, the slower the speed of rotation of the leading screw compared to that of the mandrel, the finer the thread cut. If the movement of the saddle be very slow, the pitch becomes so small that the grooves run into one another, and the work is simply turned truly cylindrical. The leading screw is rarely used for this purpose; but, as already pointed out, an additional shaft, called the *traverse shaft*, is used to move the saddle very slowly across the bed. The operation is then known as *traversing*, in distinction to screw-cutting. The traverse shaft is usually placed at the back of the lathe, and, in Fig. 75, is denoted by T. It is not threaded, but is provided with a longitudinal groove, and carries a short worm provided with a feather, so that whilst the worm is free to slide along the traverse shaft, it is compelled to rotate with it. The worm gears with a worm-wheel at the back of the saddle. This worm wheel is keyed to a spindle carried by the saddle and which, by gearing carried in the apron, meshes with the spindle to which E is keyed. Thus when the traverse shaft rotates, the worm causes the motion to

be transmitted to the front of the saddle, and, by means of the rack *F*, causes the saddle to move along; and, in so doing, the saddle pushes the worm with it. The traverse shaft usually receives its motion through stepped cones and belting from the mandrel, and consequently the speed of traverse may be varied. Or, in the place of belting, either of the speed-change gears described in §§ 51 to 55 may be used. Thus, in Fig. 70, *A* receives its motion through the wheel *B* from the mandrel, and transmits it to the traverse shaft through one of the three pairs of wheels there described. In Fig. 71, *A* is the driving shaft, and *B* the traverse shaft. The change of speed of the traverse shaft is thus brought about by shifting over a handle instead of shifting a belt. In some modern tools the leading screw itself is used as the traverse shaft, so that the same change-gears do for screw-cutting as for traversing. When so used, the lead screw is cut with a keyway along its length, and the worm slides over the screw in the manner just described. The use of the leading screw in this dual capacity is open to the objection that, as the accuracy of the screw cut depends entirely upon the accuracy of the leading screw, it is undesirable to use it for any other purpose except screw-cutting.

For further particulars regarding screw-cutting, traversing, surfacing, and other lathe operations, reference must be made to some book on workshop practice. The device adopted for turning rods of elliptical section is described in § 99.

**§ 58. Boring and Turning Mills.**—In a lathe the work rotates on the lathe centres, and the tool has a longitudinal motion given to it. For light work, the work may be attached to a face-plate screwed on the mandrel, and, if necessary, the work may be bored out, for a limited length, in the form of a true cylinder. The arrangement is obviously not suitable for large or heavy work and, for such cases, other types of machines must be adopted. For heavy work a turning or boring mill is used, whilst for medium work a horizontal boring machine may be employed. The former machine is very similar to a lathe, in which the work rotates about a vertical axis; whilst the latter resembles a drilling machine, and will be found described in § 63.

A boring and turning mill is represented in Fig. 80,<sup>1</sup> in which the bed of the machine is denoted by A, the rotating table (on which the heavy work is attached) by B, and the boring bars (to which the cutting tools are attached) by C. The boring bars slide in the saddles D, which can be swivelled round on the heads E to any required angle for conical or taper turning; and they

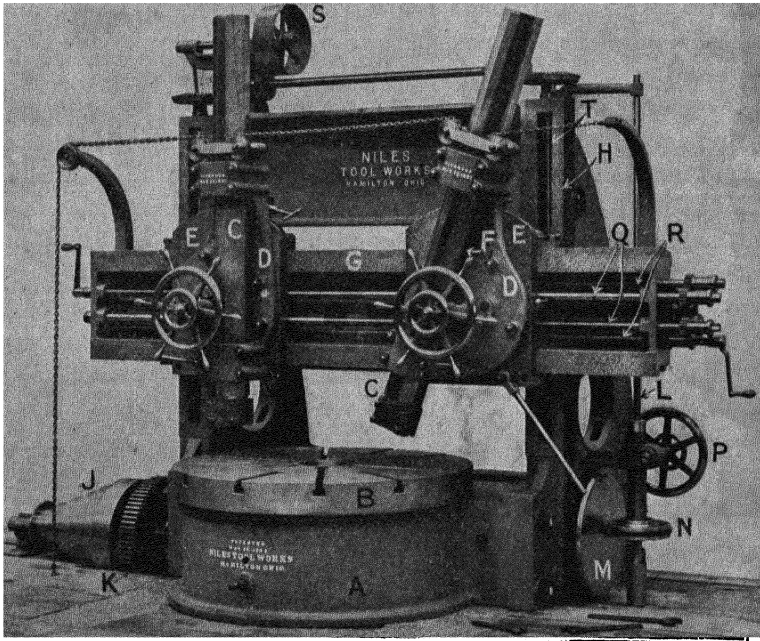

FIG. 80.

receive a longitudinal motion through a pinion and rack, F. The heads are carried by the cross-rail G, which can be raised or lowered on the vertical guides H. The motions, therefore, are identical with those in an ordinary lathe—namely, the work rotates and the tool advances in a longitudinal direction.

The table B is mounted on a long spindle of large diameter,

<sup>1</sup> The particulars of this machine were kindly supplied to the author by Mr. J W. Accles, M.Inst. M.E. The machine is by Messrs. Niles.

having a bearing at its upper end immediately under the table, and also a bearing and step at its lower end; and the framing carrying the bearings is securely attached to the bed of the machine. To take up the pressure of the table and the load upon it, the bed is also provided with an annular bearing or track near the outer circumference of the table, and upon this track the table rests. Motion is imparted to the table by an internal rack gear (not shown) of large diameter, driven by a pinion turning on a vertical stud, and connected by means of a pair of bevel wheels to a horizontal driving shaft, upon which the driving-cone pulley J is mounted. The cone pulley is mounted loosely upon the driving shaft, and imparts motion to the latter either through the back gearing K, or directly, in the usual way (§ 47). Twelve or sixteen speeds are usually provided for the table. The two heads E on the cross-rail and the two boring bars C have power feeds driven from the vertical feed shaft L shown on the right. This feed shaft receives its motion from a large metal disc, M, driven from the driving mechanism under the table, which presses against a leather friction-driving disc, N, secured to the vertical feed shaft L by a feather key. The disc N can be moved along L by means of a rack and pinion, actuated by the wheel P, and thus the revolutions of the feed shaft may be instantly varied in the manner described in § 34. The vertical feed shaft L connects by suitable gearing to the cross-feed screws Q in the cross-rail, and in this way the heads are operated along the rail. Moreover, the plain feed rods R in the cross-rail are each provided with a worm, which is connected to them by a feather key, so that the worm rotates with the feed rods, but is free to slide along them; and the worm meshes with a worm-wheel carried by the saddles, and which, by operating through a pinion on the rack, gives the necessary vertical or oblique feed to the boring bars. A convenient clutch is provided in the head, so that the boring bar can be readily connected or disconnected from the power feed and the bar operated by hand. The feeds to the heads and to the boring bars are independent of each other, and the heads or bars may be fed in the same or opposite directions at the same time by suitable change gearing

mounted on the rear side of the cross-rail. The heads are made right and left, so that they may be brought close to each other, and the boring bars are balanced. The cross-rail is elevated and lowered by power obtained from the countershaft by means of the belt driving on the pulley S, shown on the top of the machine, and suitable gearing is provided for reversing the motion of the elevating screws T.

§ 59. **Drilling Machines.**—In lathes, and also in boring and turning mills, both the work and tool have certain motions impressed upon them—the work rotating about a fixed axis and the tool moving along a straight line. In drilling machines the work is fixed, and the tool has a slow longitudinal motion along, as well as a rotary motion about, its axis, the object of the machine being to drill holes in plates, etc.

A simple form of drilling machine is shown in Fig. 81.<sup>1</sup> The motion is transmitted from the countershaft to the fast-and-loose pulley A, on to the spindle of which is keyed the speed cone B. From B the motion is transmitted to the speed cone C, and hence, either directly or through the back gearing, to the horizontal driving shaft D, in the usual way (§ 47). On D is keyed the speed cone E, which drives the coned pulley F, keyed to the horizontal feed shaft G. On G is keyed a worm, which meshes with a worm-wheel concentric with the vertical feed-shaft H. The worm-wheel is not keyed directly to H, but the arrangement is such that it can be readily connected or disconnected. When connected, the motion is transmitted from the worm-wheel, through H, to a spur wheel, I, which meshes with the wheel J, the boss of which is screwed to receive the screwed spindle K. On the shaft D is also keyed a bevel wheel, L, gearing with the wheel M, which is keyed to a hollow sleeve or casing, N. The drill spindle is provided with a longitudinal groove, in which fits a key attached to the boss of N, so that whilst N and the drill spindle have the same rotary motion, the latter can slide vertically in the boss of the former. A section of the drill spindle is shown in Fig. 82, from which it will be seen that the upper part of the drill spindle is reduced in diameter and fits into the screwed spindle K, which is hollow. The screwed

<sup>1</sup> By Messrs Redman and-Son, Halifax, Yorks.

spindle is prevented from rotating by means of a key, P, attached

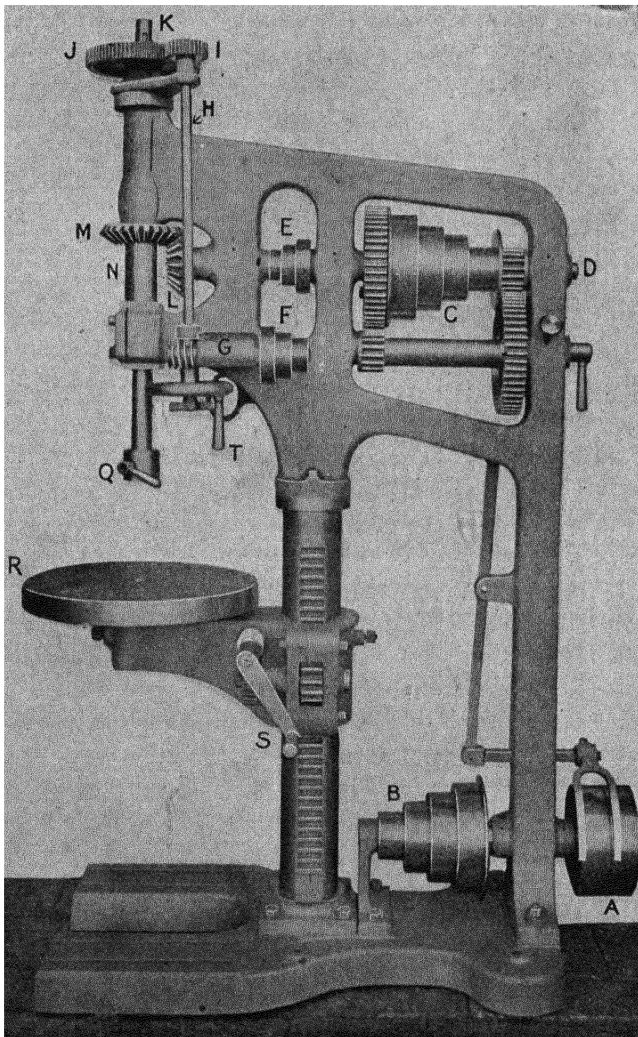

FIG. 81.

to the frame, fitting in a longitudinal groove in the screw, so that

the screwed part moves up and down without rotating; and the spindle is prevented from rising bodily by the split collar V, which is screwed to the frame. The tool is attached to the drill spindle at Q, and the work is fastened to the table R, which can be raised or lowered by means of a rack and pinion worked from the handle S (Fig. 81). If the worm-wheel be disconnected from it, the spindle H may be hand-driven by turning the wheel T.

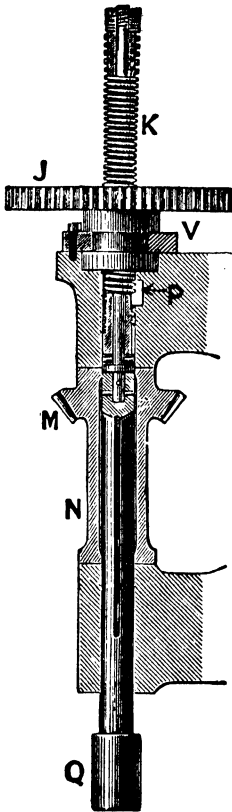

FIG. 82.<sup>1</sup>

The action of the machine is therefore as follows: the rotary motion of the spindle is directly derived from the shaft D, and the rotary motion of J through D, G, and H. In one speed of revolution of the drill there may be three speeds of the wheel I (on account of E and F being three-coned pulleys), and therefore, since the linear advance of the drill depends on the revolutions of I, there may be three linear speeds of advance of the drill. In the machine illustrated, for one speed of rotation of the counter-shaft there may be eight speeds of rotation of the drill spindle, and twenty-four linear speeds of advance of the drill spindle.

For example, suppose that the wheels L and M are equal, that the worm-wheel has 50 teeth, and is single threaded; that I and J have 20 and 60 teeth respectively; and that the largest and smallest wheels on the cones E and F are 9 inches and 3 inches in diameter respectively, and that the pitch of K is  $\frac{1}{4}$  inch.

The least advance of the drill for each revolution of the drill spindle will be when the belt is on the smallest pulley of E. In that case, for each revolution of N, L will make one revolution, G will make  $1 \times \frac{3}{9} = \frac{1}{3}$  of a revolution, H will make  $\frac{1}{3} \times \frac{1}{50} = \frac{1}{150}$  of a revolution, and J will make  $\frac{20}{60} \times \frac{1}{150} = \frac{1}{450}$  revolution. Thus the least advance of the

<sup>1</sup> Reproduced from Goodeve's "Elements of Mechanism."

drill for each revolution will be  $\frac{1}{450} \times \frac{1}{4} = \frac{1}{1800}$  inches. The greatest advance per revolution of the drill will be  $\frac{1}{1800} \times (3)^2 = \frac{1}{200}$  inches.

§ 60. **Rack-traversing Drill.**—The linear feed may be given to the drill by using a rack and pinion instead of a screwed spindle. In a *rack-traversing drill* the arrangements are exactly the same as those described, with the following exceptions. On the vertical feed shaft H (Fig. 81) is keyed a worm instead of the spur wheel I. This worm meshes with a worm wheel turning on a horizontal stud, and compound with this worm wheel is a spur pinion, which in turn meshes with a rack. This rack does not rotate, but, as before, the upper reduced part of the drill spindle rotates inside it, so that it replaces the spur wheel J and screwed sleeve K. A rack-traversing horizontal drilling or boring machine is illustrated and described in § 63.

§ 61. **Hand Drill.**—A hand clamp drill, in which the feed mechanism is different from the foregoing, is shown in Fig. 83.<sup>1</sup> The drill spindle K is rotated by the handle C through the mitre wheels L and M, the spindle of C turning in bearings in the frame Y. The spindle K is provided with a feather, by means of which the bevel wheel M and a spur wheel, N, rotate with the spindle, but which allow the spindle to slide longitudinally in the bosses of both of these wheels. The boss of a second spur wheel, P, is screwed to receive the screw spindle, and P is driven from N through the spur wheels Q and R, which are keyed to the same stud, S. Let the number of teeth in the four spur wheels be denoted by the corresponding letter, and let  $p$  be the pitch of the screw K. When the drill spindle, and therefore N, makes one revolution, the wheel P will make  $\frac{N}{Q} \cdot \frac{R}{P}$  revolutions in the same direction. Due to the rotation of N, the drill will tend to advance a distance equal to  $p$  in the boss of P; and due to the rotation of P, it tends to retreat a distance equal to  $p \cdot \frac{N}{Q} \cdot \frac{R}{P}$ . Hence the net result is that for each revolution of the drill spindle, the drill advances by an amount—

<sup>1</sup> From the *American Machinist*, March 16, 1901.

$$p \left( 1 - \frac{N}{Q} \cdot \frac{R}{P} \right);$$

and this can be made as small as we please by giving the four wheels suitable numbers of teeth. The mechanism may be made a two-speed mechanism by making P a broad-faced wheel (sometimes called a *marlborough wheel*), and so arranging matters that when the stud S is raised, Q fails to mesh with N, whilst R continues to mesh with P, but is locked or prevented from rotating

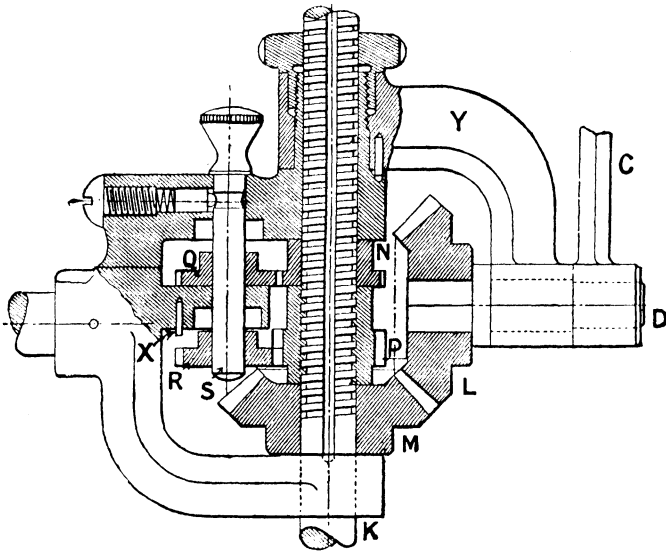

FIG. 83.

by a toothspace in R coming into contact with the fixed pin X. In that case P becomes locked, and therefore acts as a fixed nut, with the result that for each revolution of the drill spindle, the drill advances a distance equal to the pitch. The point of the drill can thus be brought quickly to the work; or, by reversing the direction of rotation, a quick return motion may be obtained.

For example, suppose that the numbers of teeth in N, Q, R, and P are 25, 24, 19, and 20 respectively, and that the pitch of the screw is  $\frac{1}{8}$  of an inch. With N and Q in gear, the linear

advance per revolution of the drill spindle is  $\frac{1}{6}(1 - \frac{25}{4} \cdot \frac{19}{20}) = \frac{1}{376}$  inch; and if the stud S be raised, the new linear advance will be  $\frac{1}{6}$  inch.

§ 62. **Radial Drilling Machines. Multiple Spindle-drilling Machines.**—In the drilling machine described in § 59, the axis of the drill is fixed in direction, and the work must be adjusted under the drill. In boiler and other work it is more convenient to

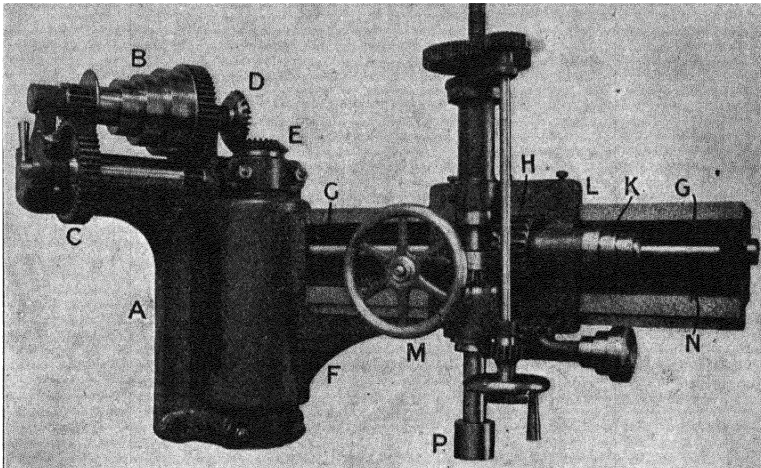

FIG. 84.

adjust the drill over the work, and in such cases a radial drilling machine may be used. A wall radial drilling machine is shown in Fig. 84.<sup>1</sup> The frame A is bolted to the wall, and carries the speed cone B and back gearing C. The motion is transmitted from the cone through the bevel wheel D to the bevel wheel E. The wheel E is carried by an arm, F, which can swivel about an axis concentric with that of E. To the axis of E is keyed a second bevel wheel (not shown) which meshes with a bevel wheel (also not shown) keyed to the horizontal spindle G, which rotates in bearings in the arm F; the arm can thus be swivelled about its vertical axis without interfering with the transmission of

<sup>1</sup> By Messrs. Redman and Son, Halifax, Yorks.

motion from B to G. The spindle G is provided with a longitudinal groove, and carries a spur wheel (not shown) which meshes with the spur wheel H, keyed to a spindle, K, turning in bearings in the carriage L. The spur wheel on G is provided with a feather which works in the longitudinal groove, so that whilst rotating with G it is free to slide along it; and it is compelled to move longitudinally with the carriage L by collars on either side of it, which are attached to L. Thus the motion of the cone B is transmitted to the shaft K; and the rotation of K causes both the rotary and axial motion of the drill in the manner already described. The carriage L carries a hand wheel, M, and to the same axis as M is keyed a spur pinion which meshes with the rack N carried by the arm. The carriage can therefore be placed in any position along the arm, and the arm can be swivelled into any position about the vertical axis; and thus the drill can be brought into any desired position over the work.

The arm F may carry two or more carriages similar to L, and thus a *multiple spindle-drilling machine* may be obtained.

A radial drilling machine, slightly modified, may be used as a slotting machine, and as a machine for cutting out oval holes in boiler plates (see § 100); also as a machine for shaping propeller blades (§ 101).

**§ 63. Horizontal Boring and Drilling Machines.**—The object of the lathe is to turn the work, externally, to the shape of a true cylinder; the object of a boring machine is to turn the work internally, or to bore the interior, to the shape of a true cylinder. In small work an ordinary lathe can be used as a boring machine. The work may be attached to a face plate, and the tool—placed parallel to the lathe axis—may be clamped to the slide rest. By advancing the slide rest by hand, or the saddle by the self-acting feed, a cylindrical surface can be bored out for a certain length.

For heavy work, special boring machines are used. A vertical turning mill has already been described in § 58, and it will there be noticed that both work and tool have motions impressed upon them. In horizontal boring machines, the work is usually fixed, and the cutting tool rotates inside the work, and also receives a slow onward motion. They are, in fact, very similar

to drilling machines in which the axis of the drill spindle is horizontal.

A modern type of horizontal boring machine is illustrated in Fig. 85.<sup>1</sup> The spindle of the machine is driven by a five-step cone pulley, A, running loosely on a long sleeve through which the boring bar B slides, the spindle being driven by the sleeve on which the cone runs by means of a keyway in the spindle, and a feather engaging with it secured in the sleeve. The main

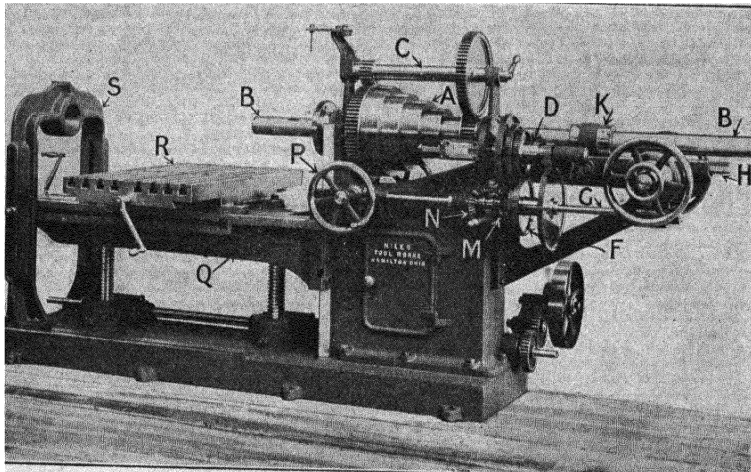

FIG. 85.

driving gear is secured to the sleeve, and motion is imparted either directly to the sleeve, and therefore to the spindle, or else through the back gear C. If motion from the cone A direct to the spindle B is required, the back gear is disengaged, and the cone is locked by the usual cone lock to the main gear (see § 47). Ten speeds are thus obtained for the spindle, ranging from the fastest speed for drilling small holes to the lowest speed for boring the maximum diameter of hole for which the machine is intended.

The advance of the boring spindle B is obtained in the following manner. A spur gear mounted on the rear end of the sleeve

<sup>1</sup> The particulars of this machine were kindly supplied to the author by Mr. J. W. Accles, M. Inst. M.E. The machine is by Messrs. Niles.

imparts motion to a short shaft, D, upon which are loosely mounted four spur gears of different diameters. These spur gears mesh with corresponding gears, F, attached to a sleeve which rides on the lower feed shaft G. By means of a traversing locking-pin, as described in § 53, any one of the four loose gears may be locked to the short shaft D, and thus, for each speed of the boring spindle, four speeds may be transmitted to the sleeve carrying F. Compound with the wheels F is a bevel pinion, M, which meshes with a second bevel pinion, N, also riding loosely upon G, through an intermediate bevel shown. Either of the pinions M or N can be keyed to G by means of a sliding clutch; and thus the spindle G may be made to rotate in either direction. From the shaft G motion is imparted to a toothed rack, H, which moves in guides underneath the boring spindle. The gear between G and H consists of a worm, worm wheel, and pinion. The rack H has at its forward end a hub, K, projecting upwards, and bored out to receive a revolving sleeve or bush pinned to the spindle; and the bush is provided with collars at each end, so that the motion of the rack is imparted to the boring spindle. Thus, according to which pinion, M or N, is in gear with G, the feed motion may be imparted to the boring spindle in either direction. A hand wheel, P, shown on the side of the machine, engages with the feed shaft G, and hand motion is imparted to the boring spindle by disconnecting (by means of the sliding clutch) the feed gearing from the feed shaft.

The longitudinal table, Q, of the machine is supported on two screws of large diameter, and, guided by the column of the machine, is elevated and lowered by power taken from the countershaft. The compound table R, mounted on the longitudinal table, has longitudinal and cross motions operated by hand, so that the work, which is fixed to R, can be brought to the tool, which is fixed to the boring spindle B. A yoke, S, is also provided to take the outer end of the boring bar, and can be clamped to the main table in any position.

The feed motion for the boring spindle may also be obtained by a screw, as in § 59, or by a mechanism similar to that described in § 61.

§ 64. Mechanism of a Steam Steering Engine.—The feed motion

for the drilling machine (§ 61) is usually termed a differential motion, because the linear advance of the screw depends on the difference in rotation between the two wheels N and P (Fig. 83), and by making that difference small (by means of the compound wheel QR), the linear advance per revolution of N can be made as small as we please, even although the pitch of the screw might be coarse. A common example of the same principle is the couplings of railway carriages. In this, the screw which couples the carriages is made right-handed at one end and left-handed at the other, so that one revolution of the swinging arm brings the carriages nearer together by a distance equal to the sum of the pitches of the two screws. The right- and left-handed screw is also adopted in a gear for transmitting the motion of the steering engine to the rudderhead in a ship (§ 116).

This principle of aggregate or differential motion is made use of for a variety of purposes, two or three applications of which may be immediately noticed.

The first refers to a steam steering engine, and illustrates an exceedingly interesting and important application. In a steam steering gear, the tiller shaft, to which the rudder is attached, is driven from the crank shaft of the auxiliary engine either directly or through gearing. The valve of this auxiliary engine is not actuated by eccentrics in the usual way, but is moved by hand. It is connected by gearing to a shaft called the controlling shaft, which is caused to rotate by being connected to the steering wheel on the bridge, or in some other part of the ship, so that a motion of rotation of the steering wheel causes a corresponding displacement of the engine valve. This displacement of the valve at once admits steam to the cylinder, starts the crank shaft, and causes the helm to be put over. But by the mechanism about to be described, the rotation of the crank shaft tends to close the valve, and will close it if the rotation of the steering wheel be stopped. Thus the rudder would be held in any position until the engine is again moved by the working of the steering wheel.

In Fig. 86,<sup>1</sup> which represents a simple type of steam steering

<sup>1</sup> Reproduced from "The Marine Steam Engine," by Mr. Sennett and Eng. Rear-Adm. Oram.

gear, R is the rod which leads to the valve, so that by moving R to the right or left we get the necessary displacement of the valve. This displacement is brought about by means of a bell-crank lever

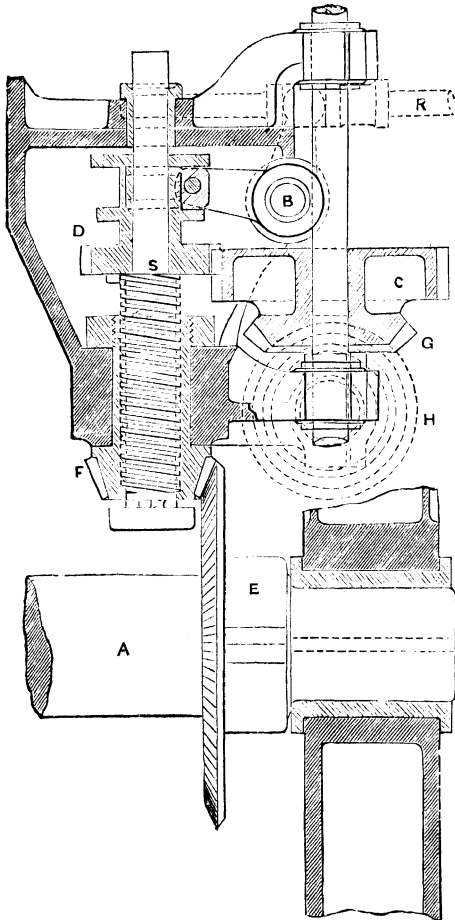

FIG. 86.

working on the fulcrum B, one end of the lever sliding in a slot in R, and the other end operated by the screw S in the manner shown. To the screw S is keyed the casting of which the spur wheel D is a part, and D gears with the broad-faced wheel C, which is compound with a bevel wheel, G. The wheel G gears, in turn, with an equal bevel wheel, H, keyed to the controlling shaft. The shaft A is driven, through gearing, from the engine shaft, and on it is keyed a bevel wheel, E, which, as the shaft revolves, works the bevel wheel F, acting as a nut to the screw S. Thus the screw S, and therefore the valve rod R, is actuated from two sources: first, from the steering wheel, which, by causing the controlling

shaft, and therefore H, to rotate, causes D to rotate, and therefore the screw S to rise or fall in the boss of F according to the direction of rotation; and, secondly, from the crank shaft of the engine, which causes F to rotate, and therefore again causes the screw S to rise or

fall. The gear is so arranged that when the engine is started in any direction by the working of the steering wheel, the wheels D and F rotate in the same direction; so that whilst the one tends to, say, raise the screw S, the other tends to lower it; or, in other words, the rotation of the crank shaft tends to replace the valve in its central position, and therefore to stop the engine. The engine only keeps in motion while the steering wheel is being worked, because as soon as the steering wheel is stopped, the engine closes the valve, and the rudder remains fixed in position until the steering wheel is again moved.

If the engine be not under steam, the wheel F will be fixed, and a certain number of turns of the controlling shaft are necessary to displace the valve from the full-closed to the full-open position; and if, when fully opened, steam is admitted, and the steering wheel stopped (so that D is fixed), the engine must make a certain number of turns before the valve is fully closed again. Expressed in other words, for each revolution of the controlling shaft the engine must make a definite number of turns before closing the valve, and the relationship between the number of turns will be the same whether the two motions take place independently or simultaneously. For example, suppose the wheels E, F, C, and D have 44, 14, 30, and 18 teeth respectively, that the screw has  $2\frac{1}{2}$  threads to the inch, and that 1" displacement of the screw causes the rod to fully open the valve. To move the screw 1", C, and therefore the controlling shaft, must make  $2\frac{1}{2} \times \frac{30}{18} = 1.5$  turns; and the tiller shaft must make  $2\frac{1}{2} \times \frac{14}{44} = 0.8$  turn to bring the screw back to its original position. Hence, if the controlling shaft make, say, 20 turns, the shaft A must make  $\frac{0.8}{1.5} \times 20 = 10.7$  turns

before the valve is closed again. And this would be true whether the 20 turns were made very quickly, very slowly, or intermittently.

§ 65. Mechanism of an Automatic Power Chuck.—A second application of differential motion which may be noticed is the mechanism of an automatic power chuck. The chuck, of which there are a variety of forms, is that part of the lathe appliances which enables the work to be attached to the lathe mandrel in a convenient manner. For metal work, the most common

type is the three- or four-jawed chuck (Fig. 87), which consists of a face plate provided with three or four jaws which are capable of sliding along radial grooves. They can be moved independently by means of screws, and the work can be truly centred by manipulating these screws. The chuck itself is fitted to the mandrel by a coarse-threaded screw at its extremity. In a self-centring chuck of this kind, the jaws are given the same radial motion by forming a spiral on the internal edge of each jaw, which works in a corresponding spiral groove of a disc which can be rotated about the mandrel centre.<sup>1</sup> The rotation of the disc causes each of the jaws to advance through the same distance towards the centre, and the work is thus truly centred. Another form of self-centring chuck is the cone chuck, which consists of a split collet or collar coned externally to fit the chuck body, and turned internally to a cylinder. By moving the split collets in or out equally, different-sized bars can be taken, and they will be truly centred. The chuck about to be described is of this type.

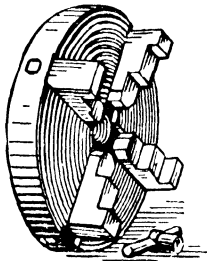

FIG. 87.

In all ordinary chucks the lathe has to be stopped to place the work in, or to remove it from, the chuck, and consequently considerable time is occupied. In the chuck represented in Fig. 88,<sup>2</sup> the chuck can be manipulated whilst the lathe is running.

The drawing represents a sectional plan. The body of the chuck B is screwed upon the end of the mandrel A in the usual manner. Its outer extremity is bored to the necessary taper to receive the split collet I, and at its inner end there is an enlarged portion cut with teeth to form a spur wheel at C. This spur wheel continuously engages the pinion D, riding loosely upon the spindle L; and upon D a steel cone, E, is securely fixed. This forms part of a double-cone friction clutch, the other parts of which are the spur wheel F, bored right and left with internal cones, and the cone K, which is securely fixed to the casing. The wheel F is

<sup>1</sup> For full description, see some book on Workshop Appliances.

<sup>2</sup> Chuck by Herbert: see paper by Mr. Ashford, *Inst. Mech. Eng.*, 1901.

mounted upon the spindle I in such a way that whilst it is free to rotate, it is constrained to move longitudinally with L by a rack-and-pinion mechanism communicating with an exterior handle, N. The teeth of the wheel F continuously mesh with those of a wheel, G, that forms part of a sleeve, which is screwed upon the chuck body B with a right-handed screw. This sleeve, G, is also threaded upon its exterior with a right-handed thread of slightly coarser

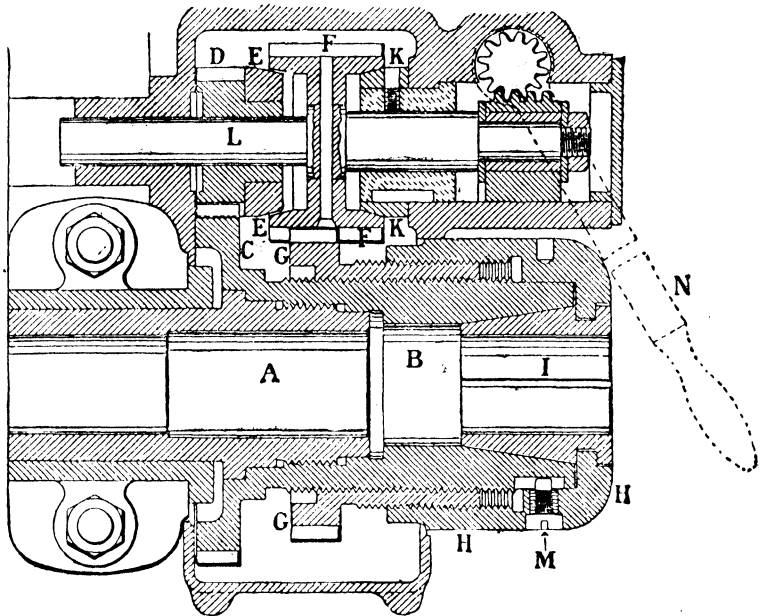

FIG. 88.

pitch, and upon it is screwed the cap H, which engages with the collet by a plain shoulder. The cap H is constrained to rotate with B, but yet to have a longitudinal motion, by the small screw M, which passes through the cap into a slot cut in the body B.

The action of the mechanism is therefore as follows. If F be out of contact with both E and K, it will simply turn idly on account of meshing with G. Moreover, since B and H *must* rotate together, the sleeve G must also rotate with them, since it is not driven from any other source. And since the external and

internal pitches of the sleeve G are slightly different, there can be no relative longitudinal motion between B, G, or H, and thus the collet is locked. But let F be pressed to the cone K, so that the wheel G is prevented from rotating, although it is free to move longitudinally. In each revolution of the mandrel A,<sup>1</sup> G (acting as a nut to B) will move over B through a distance equal to the pitch (say  $p_1$ ) of the internal screw of the sleeve G from right to left; and also, since H rotates with B, H will advance over G through a distance equal to the pitch (say  $p_2$ ) of the external screw of G from left to right, since both screws are right-handed. The net result, therefore, is that for each revolution of A, H will advance through a distance  $(p_2 - p_1)$  from left to right, and thus the collet is opened. On the other hand, if the wheel F be pressed to the cone E, for each revolution of the mandrel A (or cap H) the wheel G will make  $\frac{C}{D} \cdot \frac{F}{G}$  revolutions in the same direction, and will rotate, on account of the sizes of the wheels, faster than A. Consequently, for each revolution of A, G will move through the distance  $p_1 \left( \frac{C}{D} \cdot \frac{F}{G} - 1 \right)$  from left to right over the body B, whilst H will move through the distance  $p_2 \left( \frac{C}{D} \cdot \frac{F}{G} - 1 \right)$  from right to left over the sleeve G—the net result being that the cap H moves through a distance  $(p_2 - p_1) \left( \frac{C}{D} \cdot \frac{F}{G} - 1 \right)$  from right to left for each revolution of the mandrel, thus causing the collet I to be forced home. The motion in closing is much slower than in opening, and a correspondingly greater force can be applied in gripping the work. Thus, by simply shifting the handle N whilst the lathe is running, the collet may be opened, closed, or locked in any position.

§ 66. *Epicyclic Trains.*—When a number of circular wheels, turning about fixed centres, gear with one another, the value of the train (that is to say, the number of revolutions which the last wheel makes in a given time divided by the number of revolutions the first wheel makes in the same time) is equal to the product of

<sup>1</sup> The direction of rotation of the mandrel as viewed from the left is supposed to be counter-clockwise.

the number of teeth in the drivers divided by the product of the number of teeth in the followers. If the first and last wheels rotate in the same direction, the value of the train must be reckoned positive; if in opposite directions, negative. The wheels of the train constitute a kinematic chain, and any one of the links may be fixed. But in all cases, whichever link or wheel is fixed, the relative motion of all the other links is the same.

It is of the greatest importance to realize what is meant by relative motion in the case of bodies rotating about different axes. Consider the simple case of two spur wheels, A and B, which rotate on pins attached to an arm, P (Fig. 89). Imagine, in the first place, the arm P to be fixed, so that the train is an ordinary train; and let  $r_1, r_2$  be the radii of the wheels,  $a$  and  $c$  their centres of rotation, and  $b$  the pitch point. Let radiating lines,  $ab$  and  $cb$ , be marked on each wheel; then, if the wheel A rotate clockwise through an angle  $\theta$ , the wheel B will rotate counter-clockwise through the angle  $\phi$ , where  $\phi = \theta \frac{r_1}{r_2}$ ,

and the line  $ab$  will then occupy the position  $ab_1$ , and the line  $cb$  the position  $cb_2$ . Relatively, the two lines, and therefore the two wheels, have rotated through an angle  $\psi$ , where  $\psi = \theta + \phi$ , and the line  $cb_2$  has rotated counter-clockwise relative to  $ab_1$ . Next, instead of the arm P being fixed, imagine A to be fixed, so that P rotates about the centre  $a$ , and B rotates about the moving centre  $c$ ; and, in order to make the relative motion of A and P the same as in the first case, let the arm move through an angle  $\theta$  in a counter-clockwise direction. The

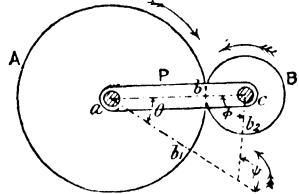

FIG. 89.

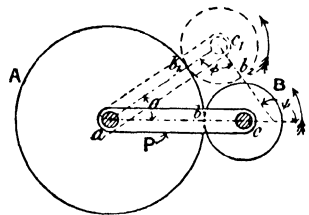

FIG. 90.

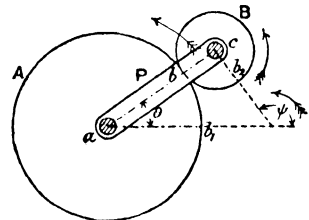

FIG. 91.

arm will then occupy the position (Fig. 90)  $ac_1$ , and the marked line  $cb$  the position  $c_1b_2$ ; and since the two wheels do not slip over each other, the arc  $b_1b_2$  must be equal to the arc  $b_1b$ , and consequently the angle  $b_1c_1b_2$  is equal to  $\phi$ . Thus the line  $c_1b_2$  has rotated, relative to the line  $ab$ , through an angle  $\psi = \theta + \phi$  in a counter-clockwise direction; and the relative motion of the two wheels is the same in the second case as in the first case. In point of fact the position shown in Fig. 90 may be obtained from Fig. 89 by imagining the wheels in the latter case locked and the whole chain to be rotated through an angle  $\theta$  about  $a$  in a counter-clockwise direction. This would bring the line  $ab_1$  in Fig. 89 in a horizontal position (that is to say, the wheel A would not have rotated at all), and the wheel B to the position shown in Fig. 91, which is exactly identical with that of Fig. 90. Thus, then, when the motion of one wheel is required relative to the second, we may first consider the motion relative to the arm, and then bring the first wheel back to its initial position (that is to say, to rest) by impressing upon everything the same angular motion; care being taken that if the wheels rotate in opposite directions, the rotations must be of opposite signs, and if in the same direction, of the same sign. The results may be conveniently expressed in the form of a table, thus—

	P.	A.	B.
P fixed	0	$+\theta$	$-\theta \frac{r_1}{r_2}$
A fixed	$-\theta$	0	$-\theta \left( \frac{r_1}{r_2} + 1 \right)$
B fixed	$\theta \frac{r_1}{r_2}$	$\theta \left( \frac{r_1}{r_2} + 1 \right)$	0

The first line of the table shows the angles turned through by A and B when P is fixed, the negative sign being attached to B, because if A rotate in a clockwise direction, B rotates in a counter-clockwise direction. The second line is derived from the first by subtracting  $\theta$  from each term of the first line, so that A is brought to rest; P rotates through the angle  $\theta$  in a counter-clockwise

direction, and B through the angle  $\theta\left(\frac{r_1}{r_2} + 1\right)$ , that is  $\psi$ , also in a counter-clockwise direction (Fig. 90). The third line is derived from the first by adding  $\theta\frac{r_1}{r_2}$  to each term of the first line, so that B becomes fixed, P relatively to it rotates clockwise through the angle  $\theta\frac{r_1}{r_2}$ , and A clockwise through the angle  $\theta\left(\frac{r_1}{r_2} + 1\right)$ . Thus, according to which link is fixed, the motions of the other links relatively to it may be obtained.

When the arm is fixed, the train is called an *ordinary* train of wheels; when one of the wheels is fixed, the train is called an *epicyclic* train, because every point in a moving wheel describes either an epicycloid or hypocycloid relatively to the fixed wheel.

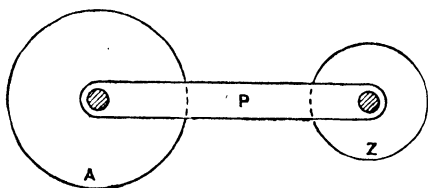

FIG. 92.

The method described above may be followed whatever the number of wheels. Thus (Fig. 92) let A be the first and Z the last wheel of the set; and let the value of the train, as computed in the ordinary way, be  $\pm e$ , the positive sign being taken if the first and last wheels rotate in the same direction, and the negative sign if they rotate in opposite directions relatively to the arm. Then, if A make  $n_a$  revolutions, the tabular form of expression gives—

	P.	A.	Z.
P fixed	0	$n_a$	$\pm en_a$
A fixed	$-n_a$	0	$n_a(\pm e - 1)$
Z fixed	$\mp en_a$	$n_a(1 \mp e)$	0

§ 67. **Reverted Trains.**—A case which very frequently arises in epicyclic trains is when the axes of the first and last wheels are coincident, and the chain in such a case is called a *reverted train*. In Fig. 93, A and D are two independent wheels rotating about

the same axis, and B and C are compound with each other, or are keyed to the same spindle; A meshes with B, and C with D.

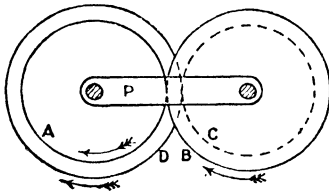

Fig. 93

If letters denote the number of teeth in the different wheels, it is clear—apart from what has been already said—that if A make one revolution relative to P in a clockwise direction, D will make  $\frac{A}{B} \cdot \frac{C}{D}$  revolutions in the same direction; consequently, for each

revolution made by A, D lags behind A by  $(1 - \frac{AC}{BD})$  revolutions; that is to say, that D relative to A moves counter-clockwise through  $(1 - \frac{AC}{BD})$  revolutions for each revolution which A makes relative to P in a clockwise direction; or, in other words, if A be fixed and P make one revolution counter-clockwise relative to it, then D will make  $(1 - \frac{AC}{BD})$  revolutions counter-clockwise relative to A. Expressed in the tabular form—

P.	A.	D.
0	1	$\frac{A}{B} \cdot \frac{C}{D}$
-1	0	$-(1 - \frac{AC}{BD})$
$-\frac{AC}{BD}$	$1 - \frac{AC}{BD}$	0

By means of reverted chains, a very high reduction of speed may be obtained in a very compact form. Thus, suppose the follower has to rotate at  $\frac{1}{2500}$  of the speed of the driver and in the same direction. To use an ordinary train would mean a very large wheel, or a considerable number of smaller ones; but by using a reverted train the desired reduction may be conveniently made. In such a case, the wheel (A, Fig. 93) would be fixed, the

driver would be the arm P, and the follower the wheel D. For each revolution made by P, D makes  $\left(1 - \frac{AC}{BD}\right)$  revolutions in the same direction; whence—

$$1 - \frac{AC}{BD} = \frac{1}{2500}$$

$$\text{or } \frac{AC}{BD} = \frac{2499}{2500} = \frac{49 \times 51}{50 \times 50}$$

Thus, if the number of teeth in A, B, C, and D be 49, 50, 51, and 50 respectively, D will only make 1 revolution whilst P makes 2500, the directions of rotation being the same. It will be noticed that  $(A + B)$  is not equal to  $(C + D)$ , so that the pitch of the teeth of A and B cannot be the same as that of C and D.

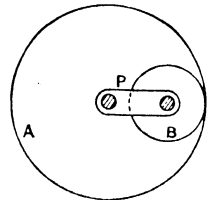

FIG. 94.

§ 68. Annular Wheels. Straight-line Motions.

—A high reduction in velocity ratio may also be obtained by using an annular wheel. Thus, in Fig. 94, B gears internally with the annular wheel A, and the table shows that if A be fixed and the arm P make one revolu-

P.	A.	B.
0	1	$\frac{A}{B}$
- 1	0	$\frac{A}{B} - 1$

tion relatively to it, the wheel B makes  $\left(\frac{A}{B} - 1\right)$  revolutions in the opposite direction; and the latter may be made as small as we please by making B sufficiently nearly equal to A. Thus, if A have 21 teeth and B 20 teeth, B makes  $\frac{1}{20}$  of a revolution for each revolution of P.

Again, if B is made half the size of A, B rotates at the same speed as P, but in the opposite direction. If (Fig. 95) a radial line, *bc*, be scribed on the wheel B, the extremity *c* will trace

out a diameter of the wheel A—since the angle  $cab$  is equal to the angle  $acb$ , and  $ab$  is equal to  $bc$ . By means of gearing, therefore, a straight line may be generated. The same result may be brought about by external gearing provided the last wheel is half the size of the first, and rotates, relative to the arm, in the same direction. Thus, in Fig. 96, B is half the size of A, and the idle wheel C may have any size, its object being to make A and B rotate in the same direction relative to P. The table shows

P.	A.	B.
0	1	2
-1	0	1

that if A is fixed, B rotates at the same speed as P, but in the opposite direction; consequently, if a radial arm,  $bd$ , be attached

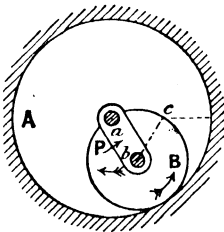

FIG. 95.

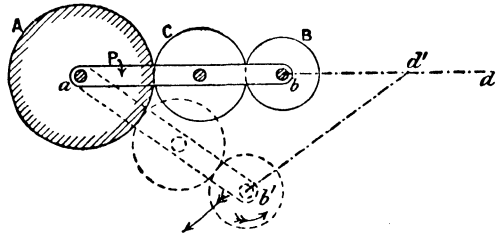

FIG. 96.

to B so that  $bd$  is equal to  $ab$ , the extremity  $d$  will trace out a horizontal straight line.

**Illustrations of Epicyclic Trains.**—A few further illustrations of epicyclic trains may be of interest.

§ 69. **Cyclometer.**—The mechanism of a cyclometer for measuring the distance traversed by a bicycle is as follows (Fig. 97): A is a fixed annular circular wheel of 22 teeth having  $a$  as centre; B is a wheel of 23 teeth which rides loosely on a pin at  $a$ ; and C and D are two wheels, having 19 and 20 teeth respectively, which are attached to each other, and which turn on a pin,  $c$ , attached to an arm,  $ac$ , which can turn about  $a$ . The wheel C meshes with A, and

D with B. The arm *ac* receives its motion from the bicycle wheel, and makes one-fifth of a revolution for each revolution of the wheel. Find the diameter of the wheel, so that B will make one revolution for each mile run.

P.	A.	B.
0	1	$\frac{22}{19} \cdot \frac{23}{23}$
-1	0	$(\frac{22}{19} \cdot \frac{23}{23} - 1) = \frac{3}{19}$

Expressing the results in tabular form, we see that—A being fixed—when the arm P makes one revolution, the wheel B makes  $\frac{3}{19}$  revolutions in the opposite direction; or, for each revolution of B, the arm makes  $\frac{19}{3}$  revolutions, and therefore the wheel  $\frac{2185}{3}$ , that is, 728 $\frac{1}{3}$  revolutions. Hence, if the wheel cover one mile, its diameter in inches must be  $\frac{5280 \times 12}{\pi \times 728\frac{1}{3}}$ , that is to say, 27.7 inches.

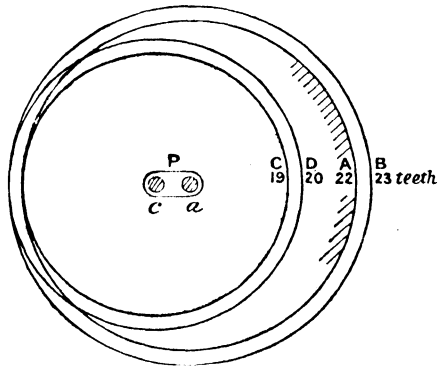

FIG. 97.

§ 70. Caldwell's Steer-

ing Engine.—One example of a steam steering gear has already been described in § 64, and its object was there fully described. A second controlling mechanism, which serves the same purpose, is illustrated in Fig. 98, and refers to Caldwell's engine. Upon the engine shaft A is a single-threaded worm, B, which gears into a worm wheel, C, having 12 teeth. Upon the same shaft as C, and rigidly connected to it, is the pinion D having 23 teeth; and D drives the spur wheel E, which has 50 teeth. Concentric with E is the controlling shaft F, on the end of which is fixed the pinion G, having 13 teeth. On the inside of E are arranged 39 internal teeth, H; and gearing into both G and H is the pinion K, also having 13 teeth. The journal I,

upon which K revolves, drives the arm M upon the sleeve N, which rotates on the controlling shaft and actuates the valve on the engine by means of the eccentric O. A rotation of F causes a rotation of N, and therefore opens the valve; whilst the shaft A, thus set in motion, tends to rotate N in the opposite direction.

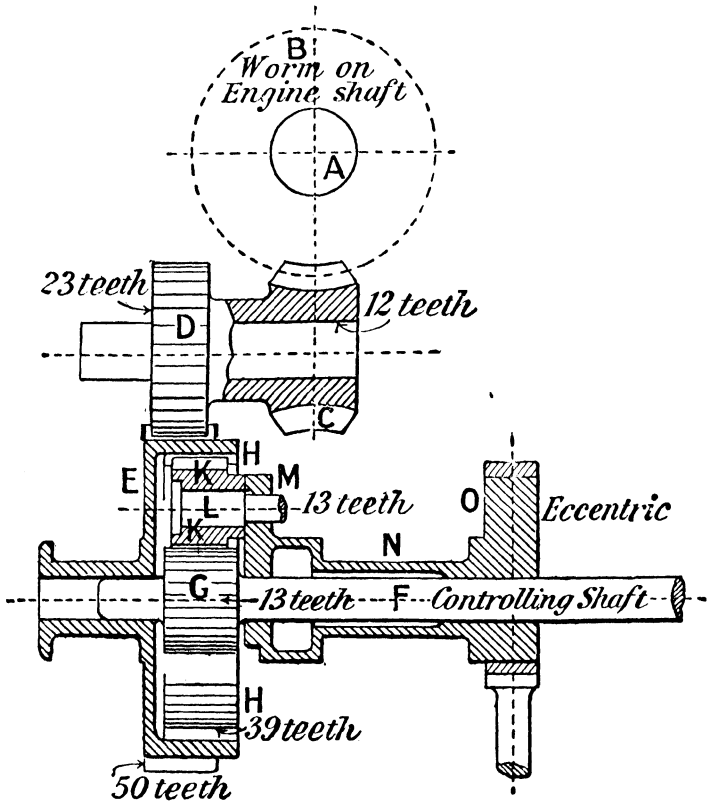

FIG. 98.

and therefore closes the valve. If the steering engine has to make 70 revolutions to put the helm from hard over to hard over, estimate the corresponding number of turns required to be made by the controlling shaft; and if the controlling shaft has to make a third of a turn to fully open the valve, find the number of revolutions the engine must make to close the valve again.

In this mechanism, as also in that of § 64, the required revolutions of A and F are the same whether they rotate simultaneously, or whether the motion is continuous or intermittent. Thus, for example, if the engine remain at rest, one revolution of F will cause a certain number of revolutions of the arm M, and therefore a certain angular displacement of the eccentric O; and if the shaft F now remain at rest, the engine will have to make a certain number of turns to bring the arm M back again to its original position; and the number of turns made by A will not depend upon whether the engine starts working immediately the controlling shaft is turned. Since we are not directly concerned with the rotation of M, and eventually M comes back to its original position, the mechanism may be looked upon as an ordinary train in which the arm M is fixed. In that case, 70 revolutions of the engine shaft would cause the controlling shaft to make  $1\frac{1}{2} \times \frac{2}{3} \times \frac{3}{4} \times 70 = 8.02$  turns; or, expressed differently, when F is fixed, 70 revolutions of the engine will produce the same angular displacement of M as 8.02 revolutions of F when the engine, and therefore E, is fixed, but in the opposite direction. Thus, if one-third of a turn of F fully opens the valve, the engine must make  $\frac{70}{8.02} \times \frac{1}{3} = 2.89$  turns to close it again.

If the controlling shaft make the 8.02 turns before the engine

F.	M or O.	E.
1 3	0 3	-1 0

starts, so that E remains fixed, the eccentric O will make (see table)  $\frac{8.02}{4} = 2.005$  revolutions; and, the controlling shaft now being held, the 70 revolutions of the engine would turn the arm M back again through 2.005 revolutions.

**§ 71. Jack-in-the-box Mechanism. Application to Motor-Cars. Difference in Speed of Two Shafts.**—The preceding trains consist of spur wheels, but epicyclic trains may also be made up of bevel

wheels. A familiar illustration of the latter is the jack-in-the-box mechanism, illustrated in Fig. 99. The spindles A and B carry two equal bevel wheels, C and D, which mesh with the wheels E and F, rotating loosely upon a spindle, G, attached either to a sleeve rotating loosely about the common axis of A and B, or to a box, K (as shown), which is supplied with bosses, H, surrounding the shafts A and B. The shafts A and B are independent, and may be driven at different speeds; and the speed of the spindle G, and therefore the box K, about the common axis of the two shafts will depend on the relative

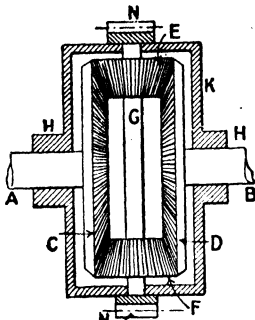

FIG. 99.

speeds of A and B. For example, if A and B rotate at the same speed in the same direction, the wheels E and F are locked, and the spindle G, with the box, rotates solid with A and B; or, if A and B rotate at the same speed in opposite directions, the spindle G, with the box, remains stationary. The tabular form of expres-

A.	K.	B.
$n_a$	0	$-n_a$
$n_a + n_k$	$n_k$	$-n_a + n_k$

sions shows that if  $n_a, n_b, n_k$  be the number of turns made by the two shafts and the box respectively, the number of turns made by the box is half the algebraic sum of the number of turns made by the two shafts, and that it will rotate in the direction of the shaft which has the greater speed.

The jack-in-the-box mechanism is used for a variety of purposes, two of which may be noticed—namely, (1) its application to motor-cars; and (2) to determine the difference in speed between the starboard and port engines in a ship.

In a *motor-car*, the back axle is invariably the driving axle, and the front axle the steering axle. When running on the straight, the four wheels (if they are of the same size) rotate at

the same speed, and, in order to turn a sharp corner with safety and ease, the mechanism ought to be such that the axles of the four wheels always intersect in one point, and the wheels should be free to take up different speeds of rotation. One mechanism which satisfies the required condition for the front axle is described in § 98; and the mechanism generally adopted on the back axle is that just described. The back axle is made in two parts, A and B, and the back wheels are keyed to them (Fig. 99); whilst the box K has frequently external teeth, N, which mesh with a spur pinion driven from the engine. The speed of rotation of the box is therefore governed by that of the engine, and, when

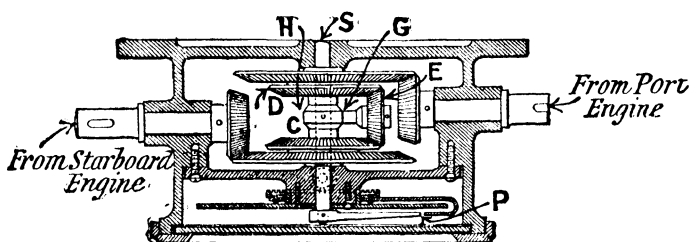

FIG. 100.

running on the straight, the axles A and B rotate at the same speed as K; but when turning a corner the mechanism allows them to rotate at different speeds, the relation between the speeds being as stated above.

In the second application which may be noticed, namely, to detect the difference in speed between the starboard and port engines of a ship,<sup>1</sup> the arrangement is as sketched in Fig. 100. The wheels C and D are driven direct, through similar gearing, from the starboard and port engines respectively, and mesh with E, which rotates on the spindle G attached to the sleeve H. The latter is keyed to the spindle S (the wheels C and D riding loosely over it), which is provided with a pointer, P. The speed of rotation of P is half the algebraic sum of those of C and D, and the direction of rotation will depend on which engine is moving the faster; whilst if the speeds of the engines be exactly equal, the pointer is stationary.

<sup>1</sup> *Engineering*, July 5, 1901.

Thus, by glancing at a dial (Fig. 101), any difference of speed is at once detected.

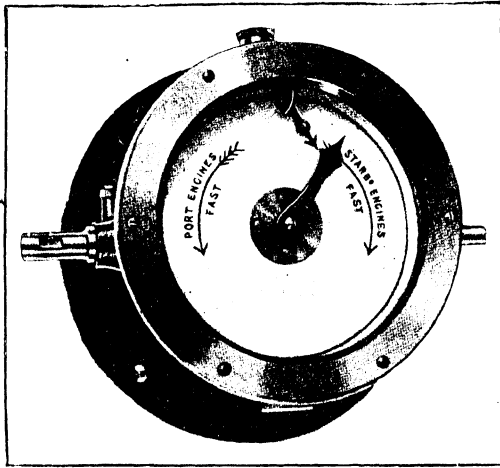

FIG. 101.

§ 72. **Humpage's Gear.**—A further illustration of an epicyclic train in which bevel wheels are used is that illustrated in half-

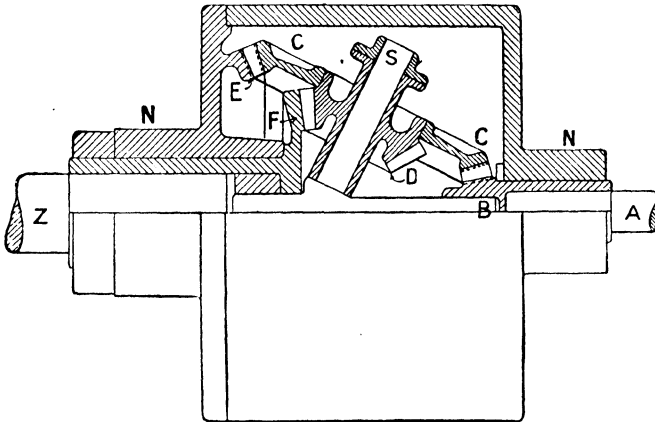

FIG. 102.

section in Fig 102, which is frequently used in lathes, capstans,

and electrical machinery.<sup>1</sup> On the high-speed shaft A is keyed a bevel-wheel B, provided with a long boss, gearing with a wheel, C (which is compound with a third one, D), which rotates loosely on a spindle, S, attached to a sleeve, the sleeve being capable of rotating about the common axis of the two shafts A and Z. The wheel C gears with a *fixed* wheel, E, and D meshes with a long-bossed wheel, F, keyed on the low-speed shaft Z. The wheels C and D are made in duplicate, in order to obtain a balance, and the whole mechanism is enclosed in a casing, N, the wheel E virtually forming part of the casing.

A.	Z.	E.	S.
1	$-\frac{B \cdot D}{C \cdot F}$	$-\frac{B}{E}$	C
$1 + \frac{B}{E}$	$\frac{B \cdot B \cdot D}{E \cdot C \cdot F}$	0	$\frac{B}{E}$

The table shows that when S is fixed, for each revolution of A, E makes  $-\frac{B}{E}$ , and Z makes  $-\frac{B \cdot D}{C \cdot F}$  revolutions; so that if E be fixed, A will make  $(1 + \frac{B}{E})$  revolutions whilst Z makes  $(\frac{B}{E} - \frac{B \cdot D}{C \cdot F})$  revolutions in the same direction, the arm S making  $\frac{B}{E}$  revolutions. Thus, for each revolution of A the shaft Z will make—

$$\frac{\frac{B}{E} - \frac{B \cdot D}{C \cdot F}}{1 + \frac{B}{E}} = \frac{B(CF - DE)}{CF(E + B)}$$

revolutions in the same direction.

For example, suppose that the number of teeth in the wheels B, C, D, E, and F are 12, 40, 16, 46, and 34 respectively, and

<sup>1</sup> *Mechanical Engineer*, March 11, 1899.

that the shaft A is coupled to a dynamo which makes 2700 revolutions per minute; the low-speed shaft Z will then rotate 256 times a minute.

§ 73. **Automatic Screw-cutting Machine.**—Many of the examples of machine tools already considered illustrate the progress which has been made in the various details connected with modern machine tools. The simple automatic tool about to be described is not only a further illustration, but it is also an example of a tool using an epicyclic train. The objects which have to be kept in mind are to bring about the desired change in the quickest possible manner, with the minimum of labour, and without stopping the machine. In many cases, such as, for example, the quick return motion of the table of a planing machine (§ 43), the change is brought about by the machine itself, and is therefore strictly automatic; and in many other cases, such as the back gearing of lathes (§ 48), or the chuck (§ 65), the labour and skill involved in effecting the change are so slight that not infrequently they, likewise, are termed automatic.

When the same article has to be reproduced in great numbers,

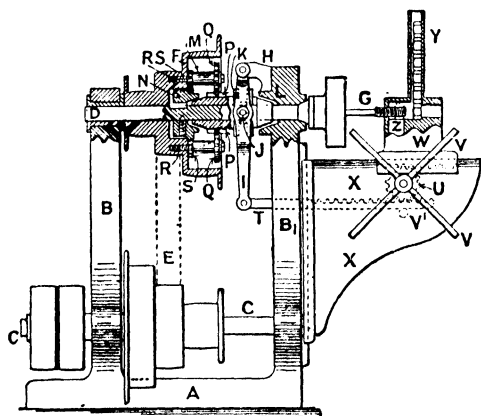

FIG. 103.

the modern tendency is to have a special machine which turns out the desired article only; and in designing such a machine, the three requisites mentioned above have to be kept in mind. The machine may be fairly simple or very complex, according to its requirements. The machine illustrated in Fig. 103 refers to a machine the object of which is to screw or tap small nuts.<sup>1</sup> The points to be kept in view are: (1) to allow the machine to run at

<sup>1</sup> From the *Mechanical Engineer*.

a slow speed when cutting or tapping the screw; (2) to allow the machine to run at a quicker speed in the opposite direction when the nut is being released; and (3) to make the withdrawal of the tool and the change of speed take place simultaneously and by one operation. These conditions are satisfied in the following way. The spindle D is driven from the shaft C (fitted with a fast and loose pulley at the overhanging portion to the left) by the coned pulleys E and F. The pulley F is free to rotate on the spindle D, and carries two studs, M, on which the compound pinions Q and S turn. The wheel S gears with a pinion, N, keyed to the spindle D, whilst Q meshes with a pinion, P, firmly attached to a slider, K, which rides quite loosely on the spindle D. This slider is coned at each end to fit into corresponding cones in the wheel N and frame B<sub>1</sub> respectively; and it can be moved along D by means of the lever I suspended from the projection H of the frame, the pins J working in a groove turned in K. The lever I is actuated by a rack, T, meshing with a pinion, U, turning on a stud, and rotated by the hand-wheel V. The rack is kept in gear with the pinion, and is free to have a slight angular motion by resting on a stud, V'. The pinion U also gears with a rack attached to the traveller or slide W, so that the same motion of U pushes W to the right and T to the left, and conversely. The slide W carries the chute Y, in which are piled a series of the blank nuts which have to be screwed. The lower one rests against a ledge in the slide, so that when the tool G presses against it, it remains stationary and allows the screw to be cut or tapped.

The action of the machine is therefore as follows: By rotating the hand-wheel V counter-clockwise, the nut is brought up to G, and, by the same operation, the rack T is moved to the right, and the slider K pressed against the cone L in the frame. The wheel P is therefore prevented from rotating, so that Q, the stud of which is carried round with the cone, runs round P and, through S, causes N and the spindle D to rotate with a certain velocity in a certain direction. The wheels therefore constitute an epicyclic train, in which P is fixed; and for each revolution of the arm (that is to say, of the cone), the wheel N (and therefore the spindle

D) will make  $\left(\frac{PS}{QN} - 1\right)$  revolutions in the opposite direction, the letters denoting the number of teeth in the wheels. This may be made as small as we please by suitably choosing the number of teeth in the different wheels; in other words, N may be made to revolve in the opposite direction to the cone F, and with a much less velocity. The tool G will consequently rotate slowly, and, as the table is gradually fed forward by the handle V, the thread is cut. Immediately the tool is through the nut, the slider W is moved quickly to the right, so that the nut still remains on the tool (as shown). Simultaneously the rack T moves to the left, and presses the slider K against the cone in N. The train of wheels is then locked, and the speed-cone F, K, and N then rotate together, so that the tool has now a much quicker speed than before, but in the opposite direction. The nut carried on the tool, and which is prevented from rotating, quickly releases itself from the tool and falls in the hole Z. The hand-wheel is again reversed, and the same operation repeated on the new blank which has, in the mean time, fallen against the ledge.

This only represents a simple case of a self-acting machine, but it sufficiently illustrates the general characteristics of all. In all such cases the operator has practically only one thing to do (in the above case it is the rotation of the hand-wheel), all the remaining motions taking place automatically; and considerable time is saved by making the speeds much faster when the tool is not cutting than when it is cutting. More complicated cases of automatic tools will be found in the technical press.

§ 74. **Intermittent Circular Motions—Ratchet Wheels.**—In the examples on toothed gearing already given, a continuous motion of one wheel causes a continuous motion of the second wheel. This is due to the fact that each wheel is provided with a number of teeth, so that there is always one pair of teeth in contact. If one of the wheels is only provided with *one* tooth, and the height of the tooth is such that, between the interval of coming into contact with a tooth of the second wheel and of escaping from contact with that tooth, it just pushes the second wheel through a distance equal to the pitch, then, when the first wheel makes one complete

revolution, the tooth on it will come into contact with the next tooth of the second wheel, and will again push the second wheel through a distance equal to the pitch, the second wheel, in the mean time, remaining at rest, since no teeth on the first wheel engage with it. Thus, if the second wheel have ten teeth, it will make one revolution, whilst the first wheel makes ten revolutions.

Intermittent motions may also be brought about by the use of ratchet wheels. In Fig. 104, the *ratchet wheel* A, keyed to the spindle B, is provided with saw-shaped teeth, C; and the *click* D is pivoted at the extremity E of an arm, F, which vibrates loosely on some spindle the axis of which is parallel to that of A. As shown, the arm vibrates loosely over the spindle B itself; but this need not be the case. The click is kept in contact with the ratchet either by means of its own weight or by springs. If the arm F vibrates from right to left, the click pushes the ratchet through a certain angle, also to the left; but on the return stroke of the arm, the click D slides over the teeth of the wheel, and the wheel remains at rest. To prevent the wheel reversing during the return stroke of the arm, a *catch*, G, turning on a fixed axis, H, is usually provided. During the forward stroke of the arm, the ratchet slides under G. When driving, the arm, click, and ratchet move as one piece, so that the combination forms a simple lever.

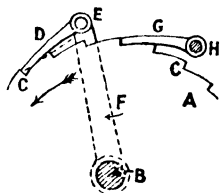

FIG. 104.

Clearly, for effective working, the click must not tend to disengage itself from the ratchet during the forward stroke. For this to be the case, a certain condition has to be satisfied. The direction of the force between the click and ratchet is normal to the tooth at C, and the direction of that normal (shown dotted) ought to be such that it intersects the arm below E, so that the click tends to rotate counter-clockwise about E. The same condition ought to be satisfied for the catch, in order to effectively hold the ratchet when the click is not driving.

Again, in Fig. 104 the click and catch act by thrusting; but they may equally well act by pulling, as in Fig. 105. In the

latter case, the normals to the teeth of the ratchet must, to guard against disengagement, intersect the arm above E.

A click may be made reversible by giving the ratchet wheel teeth of ordinary shape, and by throwing the click over to occupy the dotted position (Fig. 106). As represented by the full-lined position of the click, the direction of rotation of the ratchet wheel would be counter-clockwise; if the click be thrown over, the direction of rotation of the ratchet wheel would be clockwise.

The click may be made double acting by the device shown in Fig. 107, which is frequently referred to as the *levers of La Garousse*. As in Fig. 104, the ratchet wheel is denoted by A, and a bell-cranked lever, F, oscillates through a certain angle about the

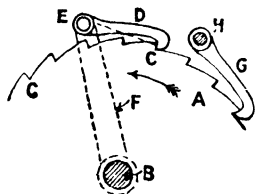

FIG. 105.

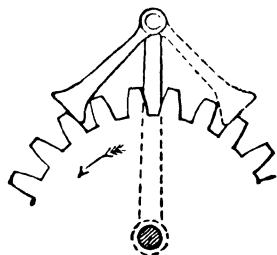

FIG. 106.

spindle  $B_2$ . The clicks are attached to the two extremities  $E_1$  and  $E_2$ , so that whilst one click,  $D_1$ , is pushing, the other,  $D_2$ , is sliding over the ratchet. Thus the motion of the ratchet wheel  $B_1$  is almost continuous, the wheel being only at rest for a moment when the lever F reverses its direction.

#### § 75. Methods of varying the Angular Motion of the Ratchet.—

The angle turned through by the ratchet for each vibration of the arm is slightly less than the angular motion of the latter, since the click must clear the tooth of the former before engaging again. The angular motion of the ratchet, that is to say, the number of teeth over which the click slides on its return stroke, may be varied in different ways; such as—

(1) Keeping the angle of vibration of the arm constant, the point of attachment E of the click D (Fig. 104) may be altered. The nearer E is to B, the less the travel of the click, and therefore

the less the angular motion of the ratchet for each swing of the arm.

(2) Keeping the pin *E* the same, the angular motion of the arm may be varied. When applied to machine tools, the arm is usually vibrated through links from some continuously rotating spindle, or from some reciprocating piece, of the machine. The angle through which the arm vibrates may be varied either by altering the length of the connecting links or by the device shown in Fig. 108. In that figure, *A* represents the ratchet wheel, *F* the vibrating arm (riding loosely about *B*), and *D* the click. In addition, *M* is a circular plate which also rides loosely over *B*, and which is provided with a circular slot, *N*, in which two studs,

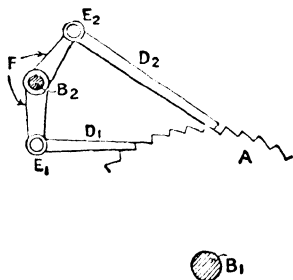

Fig. 107.

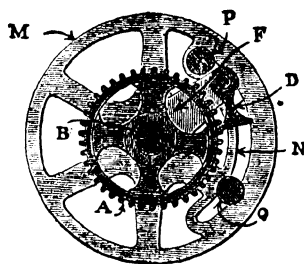

Fig. 108.

*P* and *Q*, may be clamped in any desired positions, the pins being on opposite sides of the arm *F*. The plate *M* receives an unvarying amount of angular vibration from some part of the machine. If the studs *P* and *Q* be clamped close to the arm *F*, the arm will move with the plate *M*, and its angular motion will be the same as that of the plate; but if the angle which the arc between *P* and *Q* subtends at *B* be greater than the angular motion of the plate *M*, then the plate will make its complete swing without the studs coming in contact with *F*, and thus the arm, and therefore the ratchet wheel, will remain at rest. Thus by varying the position of the studs *P* and *Q*, the angle of oscillation of the arm may be varied, the angular motion of the arm being the difference between the angular motion of the plate *M* and the angle which the arc

PQ (measured from inside to inside of the studs) subtends at the centre B.

Intermittent motions may be also brought about by causes which are discussed in Chapter VIII.

§ 76. **Applications of Ratchet Wheels.**—Ratchet wheels are used for a variety of purposes, only one or two of which need be noticed.

(1) *Ratchet Brace.*—In the ratchet brace used for hand-drilling (Fig. 109), a rotation of the ratchet advances the drill spindle by means of a screw and nut. The vibrating arm rides loosely over the spindle, and a click is pressed against the ratchet by the spring. The arm is vibrated by hand, and the angular motion of

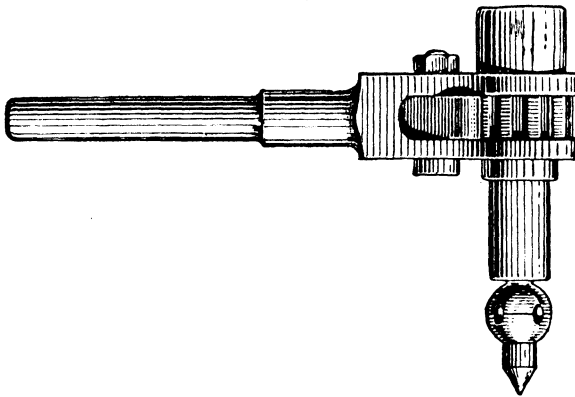
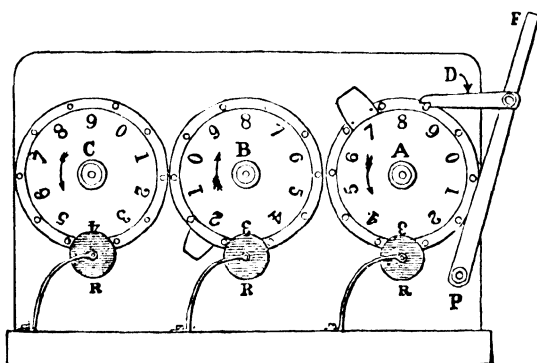

FIG. 109.

the ratchet will depend on the magnitude of the swing given to the arm; so will the linear advance of the drill when the screw is held to prevent rotation, but the feed can be reduced by allowing the screw partial angular motion; in other forms the screw turns with the ratchet and the nut may be held.

(2) *Engine Counters.*—The principle of all engine counters, the object of which is to record the number of revolutions of the engine shaft, is shown in Fig. 110. It consists of a number of wheels turning about parallel axes, A, B, C, each wheel being provided with ten pins and one tooth. The tooth on one wheel meshes with the pins of the next, and is of such a length that it pushes the next wheel through a distance exactly equal to the

pitch between the pins, that is to say, through one-tenth of a revolution, as already explained in § 74. The first wheel A is caused to intermittently rotate by means of the click D and the arm F, which vibrates about the centre P, the angle of vibration being such that the wheel A is pushed through one-tenth of a revolution. The extremity of the arm F is attached by means of a link to a pin placed eccentrically on the end of the engine shaft, so that for each revolution of the engine shaft the arm F makes one complete vibration, and the wheel A one-tenth of a turn; for each revolution of A the wheel B makes one-tenth of a turn; and so on. Each wheel is provided with a numbered dial registering

FIG. 110.<sup>1</sup>

from 0 to 9, and through apertures in the frame the top number on each dial may be read. Thus the reading of A will give the revolutions, that of B the tens of revolutions, and that of C hundreds of revolutions. As shown, the reading is 988. The wheels are prevented from running back by rollers, R, mounted on springs. Engine counters differ in detail, but all consist of either ratchets or one-toothed wheels.

(3) *Cross-feed of Planing and Shaping Machines, etc.*—We have already pointed out that in a planing machine the work moves, and the tool, during cutting, remains fixed; in a shaping machine the work is fixed, and, whilst cutting, the tool moves longitudinally

<sup>1</sup> Reproduced from Goodeve's "Elements of Mechanism."

over the work. In both cases, between two strokes, the tool must be moved a certain distance across the work, so that it will cut fresh metal the next stroke. Thus, in addition to the reciprocating motion, provision must be made whereby the tool-box has an intermittent motion across the work, the tool-box having a certain cross motion during the return or non-cutting stroke, but not having this motion during the cutting stroke. This intermittent cross motion may be brought about either by hand or, automatically, by ratchets. Referring to Fig. 60, which represents a planing machine, the tool-box C is carried by the cross-rail D, which can be raised or lowered on the vertical guides E in order to adjust the tool to the proper height. But, in addition to these motions, the tool-box meshes with a screw, carried by the cross-rail, by means of a nut, so that by giving this screw a slight motion of rotation during each return stroke the tool-box is fed along the cross-rail. This may be given by hand or by means of ratchets. The arrangement differs in different machines, but in all there is some means of varying the feed. One arrangement (Whitworth's) has been already described in § 75, in which the ratchet A is keyed to the screw-spindle at its extremity, B. The plate M receives its vibrating motion from the reciprocating table, and the amount of cross-feed is regulated by altering the positions of the studs P and Q.

**§ 77. Descriptive Details of other Machine Tools.**—Other mechanisms and machine tools, used for special purposes, will be found described in Chapters III. and IV.

## CHAPTER III.

### *MECHANISMS POSSESSING SOME PARTICULAR GEOMETRICAL PROPERTY.*

§-78. THE mechanisms discussed in the preceding chapter consist of combinations of belting and gearing—the question of linkwork having been only mentioned incidentally—and refer principally to machine tools and shop appliances; and the object has been to discuss the modification of motion produced. In an important class of mechanisms, it is not so much the modification of velocity, as the paths which the different points of the mechanism trace out, which is of interest. Very frequently some point or tool is required to trace out a particular curve, such as a circle, a straight line, an ellipse, or a helix; and this has to be done mechanically by a combination of links. If the force to be transmitted is small, the combination is termed an instrument (§ 6); if considerable, a machine.

From a mechanical point of view, the circle is the easiest curve to generate. If a point is required to move in a circular arc, it need only be attached by a link of constant length to a spindle which rotates in fixed bearings, as in the ordinary crank shaft, arm, and pin arrangement. In the case of a circle, therefore, the curve is *generated*, that is to say, a previously existing circle is not merely used as a copy. But if any other curve, such as a straight line or ellipse, has to be traced out, we must either copy a previously existing straight line or ellipse, or else, by means of a kinematic chain consisting entirely of turning pairs, *generate* the required curve. We now proceed to discuss those mechanisms which either generate or copy some particular curve. The mechanisms discussed mostly consist of four lower

pairs and four elements, but others consisting of more than four pairs are also considered.

§ 79. **Parallel Motions.**—By far the most important mechanisms are those which either generate or copy a straight line. They are usually referred to as *parallel motions*.

Parallel motions may be divided into two classes, namely—

(1) Those consisting entirely of turning pairs, and in which, therefore, a straight line is either exactly or approximately generated ;

(2) Those containing one or more sliding pairs on which the accuracy of the line traced out depends, and which, therefore, may be looked upon as copying machines.

§ 80. **Peaucellier's Cell.**—Consider, first, those parallel motions which generate a mathematical straight line. The most familiar

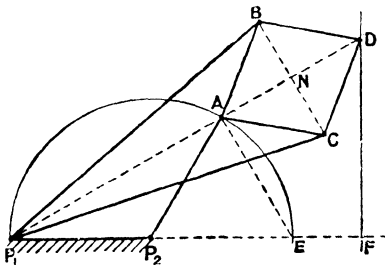

FIG. 111.

example is the mechanism known as *Peaucellier's cell*. It consists of a jointed rhombus or cell, ABCD, the links comprising it being all of the same length (Fig. 111). The pins B and C are coupled to a fixed centre,  $P_1$ , by two links,  $P_1B$  and  $P_1C$ , of equal length; whilst the pin A is coupled to a second fixed centre,  $P_2$ , by a link,  $P_2A$ ,

equal in length to the distance  $P_1P_2$  between the two centres, so that when motion takes place, A is constrained to describe a circular arc passing through  $P_1$ . Under these conditions, the fourth pin, D, will trace out a straight line perpendicular to  $P_1P_2$ . It will be noticed that all the links in the chain move parallel to one plane.

To prove this statement, it is clear that in *all* positions of the mechanism the points  $P_1$ , A, and D are collinear. Moreover, since the diagonals AD, BC of the cell bisect each other at right angles,

$$\begin{aligned} P_1A \cdot P_1D &= (P_1N - NA)(P_1N + NA) \\ &= P_1N^2 - NA^2 \\ &= (P_1B^2 - NB^2) - (AB^2 - NB^2) \\ &= P_1B^2 - AB^2; \end{aligned}$$

so that, since the links  $P_1B$  and  $AB$  are of constant length, it follows that in all positions of the mechanism the product  $P_1A \cdot P_1D$  is constant.

Now let the circle described by  $A$  meet the line of centres in  $E$ , and draw  $DF$  perpendicular to the line of centres. Since the angles  $DAE$  and  $DFE$  are each a right angle, the quadrilateral  $DAEF$  may be inscribed in a circle, and consequently the product  $P_1E \cdot P_1F$  is equal to the product  $P_1A \cdot P_1D$ , and is therefore constant. But  $P_1E = 2 \cdot P_2A$ , and is constant; hence in all positions of the mechanism the distance  $P_1F$  is constant, from which it follows that the locus of  $D$  is the line  $DF$ . In Fig. 111, the centre  $P_1$  lies outside the rhombus; but it might equally well lie inside it, as shown in Fig. 112. Precisely the same argument is applicable to either figure.

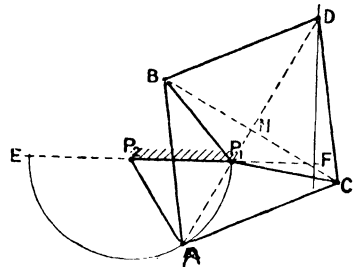

FIG. 112.

§ 81. Hart's Parallel Motion.

—Peaucellier's cell is not the only combination of links which generates a true straight line. Any set of links whatever which makes the product  $P_1A \cdot P_1D$  a constant, where  $P_1$  is a fixed centre, will enable  $D$  to trace out a straight line, provided  $A$  traces out a circle which passes through  $P_1$ . A second combination of links satisfying this condition is due to *Hart*, and

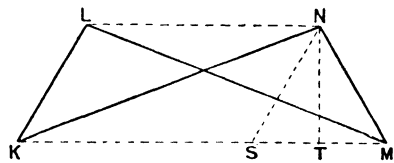

FIG. 113.

consists of a crossed parallelogram. In Fig. 113 the links  $LM, KN$  are equal, as also are  $KL$  and  $MN$ . If the links were opened out, the four links would form a parallelogram; hence the term "crossed parallelogram." It is clear that in all positions of the linkage the lines  $LN$  and  $KM$  are parallel; and, moreover, the product  $LN \cdot KM$  is constant. For, a circle goes round  $KLMN$ , and therefore

$$KN \cdot LM = KM \cdot LN + KL \cdot MN$$

$$\text{or } KM \cdot LN = KN^2 - LK^2 = \text{constant}$$



and two sliding pairs. If C be the central point of the link AB, and P the point of intersection of the central lines of the slots, it is clear that the length of the line PC is equal to either AC or CB, and is therefore constant. Consequently, as the blocks slide in their respective slots, the point C will trace out a circle of centre P, and the mechanism will not be constrained in any way by adding a crank, PC, turning about the centre P.

In that case one of the blocks may be dispensed with, and the mechanism shown in Fig. 116 obtained. So long as PC, CA, CB are all equal, the point A will describe a vertical straight line when B moves along the horizontal slot. The accuracy of the line traced out by A will depend entirely upon the accuracy of the line traced out by B, so that this mechanism is distinctly a copying machine. The block B is guided in

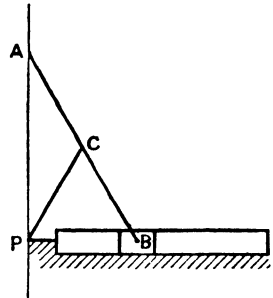

FIG. 116.

its straight-line path by contact with the surfaces of the slot; but the description of how a plane surface is produced is more a matter of workshop practice than of kinematics, and it will be found in most text-books which deal with workshop appliances. The mechanism represented in Fig. 116 is usually known as the *Scott-Russell parallel motion*.

§ 83. **Elliptical Trammels. Grasshopper Parallel Motion.**—Again, referring to Fig. 115, any point, D, in the link AB, other than the centre point C, describes an ellipse of semi-major and minor axes, AD and BD respectively.<sup>1</sup> Ellipses can therefore be described by means of this mechanism, and for that reason it is very frequently referred to as the *elliptical trammels*. Moreover, one of the slots may be dispensed with as before, provided the point D be constrained to move along its elliptic path instead of constraining C to move in a circular path. The result would be precisely the

<sup>1</sup> To prove this statement, take P as the origin of rectangular co-ordinates, the axis of  $x$  being horizontal, and of  $y$  vertical. If  $\theta$  be the inclination of AB to the horizontal, and  $x, y$  be the co-ordinates of D; then  $y = BD \sin \theta$  and  $x = AD \cos \theta$ , whence  $\frac{x^2}{AD^2} + \frac{y^2}{BD^2} = 1$ , an ellipse of semi-major and minor axes AD and DB.

same as in the Scott-Russell motion, namely, the point A would then describe a straight line. But suppose that, instead of constraining D to move along its true elliptic path, it is constrained, for reasons of mechanical simplicity, to move along a circular arc which approximates, for small displacements, to the shape of the ellipse. In that case, as B moves in the horizontal slot, the point A will describe an *approximate* vertical straight line, provided

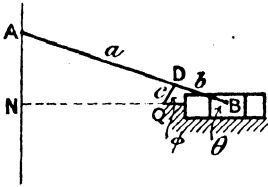

FIG. 117.

the range of motion is not too great. Usually speaking, the extreme positions of the tracing point A (Fig. 117) would be at equal distances on either side of the line of stroke of B, and the point D would describe a short circular arc of centre Q, say. The length of the radius QD will clearly depend on the lengths of

AD and DB, and may be calculated as follows: Let the lengths of AD and DB be denoted by  $a$  and  $b$  respectively, so that  $a$  and  $b$  are the semi-major and minor axes of the ellipse which D would trace out if A accurately moved along a vertical straight line; and let  $c$  denote the length of the link QD, so that the actual path of D is a circular arc of radius  $c$ . Moreover, let the inclinations of AB and DQ to the line of stroke of B be denoted by  $\theta$  and  $\phi$  respectively. The projection of A on the line of stroke of B, measured from the fixed point Q, is given by—

$$\begin{aligned} \text{QN} &= a \cos \theta - c \cos \phi \\ &= a \cos \theta - c \sqrt{1 - \frac{b^2}{c^2} \sin^2 \theta} \end{aligned}$$

$$\text{since } \sin \phi = \sin \theta \times \frac{b}{c}$$

If QN is constant, A will accurately describe a vertical line—a condition which is satisfied for *all* values of  $\theta$ , provided  $a = b = c$  as in the Scott-Russell motion. But if the range of motion be limited, the above expression may be written—

$$\begin{aligned} \text{QN} &= a\left(1 - \frac{\theta^2}{2}\right) - c\left(1 - \frac{l^2}{c^2}\theta^2\right)^{\frac{1}{2}} \\ &:: a\left(1 - \frac{\theta^2}{2}\right) - c\left(1 - \frac{b^2}{2c^2}\theta^2\right) \\ &= a - c + \frac{\theta^2}{2}\left(\frac{b^2}{c} - a\right); \end{aligned}$$

$\theta^4$  and higher powers being neglected. Thus for small displacements, QN is constant and equal to  $(a - c)$  that is to say, A sensibly describes a straight line, provided  $c = \frac{b^2}{a}$ ; and this expres-

sion gives the proper length of the link QD.<sup>1</sup> When these proportions are satisfied, we have an example of a copying machine which only *approximately* copies the straight-line motion of B,

and that for small values of  $\theta$  only. The actual displacement of the point B, within the limits to which the motion applies, will be very small compared to the displacement of A, and a link turning about a fixed centre may be substituted for the slot, as shown in Fig. 118. Provided the radius BR is sufficiently long, B will sensibly describe a horizontal straight line; and if the above proportions are satisfied, A will approximately trace out a vertical straight line. We thus get an example of a chain consisting of four links and nothing but turning pairs, which

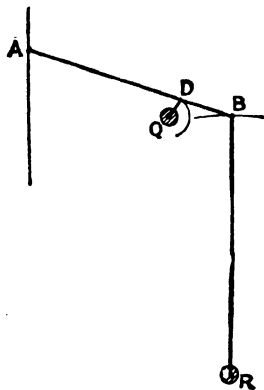

FIG. 118.

*generates* an approximate straight line. Such a chain is by far the most important of the parallel motions, and it exists in a variety of forms. The form illustrated in Fig. 118 is usually known as the *grasshopper parallel motion*.

<sup>1</sup> This expression might have been obtained otherwise. The circular arc described by D replaces the ellipse in the neighbourhood of the extremity of the major axis, the semi-axes of the ellipse being  $a$  and  $b$ . Now, the radius of curvature of the ellipse at the extremity of the major axis may be readily shown to be equal to  $\frac{b^2}{a}$ . Consequently, the radius  $c$  is simply equal to the radius of curvature of the ellipse, and this is obviously the condition which ought to be satisfied.

Generally speaking, in dealing with parallel motions, the tracing point is made to lie on the required straight line in the two extreme and mean positions of the mechanism. In such a case, if the length of the link AB and the position of the pin D in it be known, the centre Q, and the length of the radius QD, may be graphically obtained as follows :—

Let (Fig. 119)  $A_1, A_2, A_0$  be the two extreme and mean positions of the tracing point—these points lying on the vertical line—and

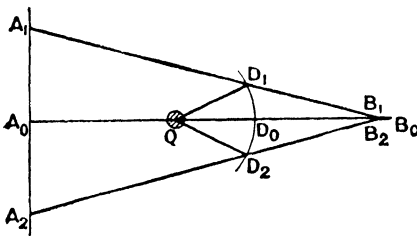

FIG. 119.

plot the link AB in the three corresponding positions so that the displacement of B is the short distance  $B_0B_1$ . Let the three corresponding positions of D be  $D_1, D_0$ , and  $D_2$ , and find the centre Q of the circle passing through them. Then Q is the required

centre, and  $QD_1$  the required radius. For intermediate positions, the tracing point will not exactly lie on the line  $A_1A_2$ , but the deviation will be so small as to be usually inappreciable. The radius BR (Fig. 118) may be of any convenient length, and the centre R may lie either above or below the line  $A_0B_0$ .

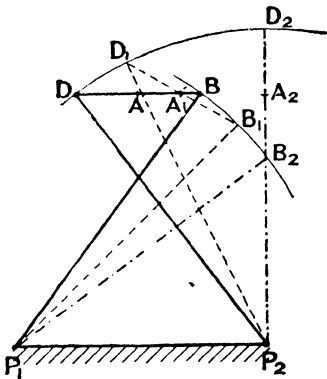

FIG. 120.

point, A, is the middle point of the coupler, and, very approximately, traces out a straight line parallel to the fixed link.

§ 84. **Chebicheff's Parallel Motion.**—A second parallel motion, consisting of four turning pairs, which generates an approximate straight line, is *Chebicheff's*. The two levers,  $P_1B$  and  $P_2D$ , are of equal length, and are crossed, and the coupler  $DB$ , in the mean position of the mechanism, is parallel to the fixed link (Fig. 120). The tracing

Thus, in the position of the mechanism represented by the broken lines, the central point of the coupler is  $A_1$ , which practically lies on the line  $BD$ . The proportions of the mechanism will, as in the grasshopper motion, depend on the limits of the motion. For example, if the coupler is vertical when either lever is vertical, and if, then, the tracing point lies exactly in the line  $BD$  produced (as shown in Fig. 120), it may be readily shown that if the length of the fixed link  $P_1P_2$  be denoted by unity, the length of either lever will be represented by 1.25, and of the coupler by 0.5. These proportions at once follow from the geometry of the mechanism, and may be left as an exercise to the reader. With these proportions, it will be noticed that the tracing point is moving in a direction exactly parallel to the fixed link in the extreme positions, as well as in the mean position, of the mechanism.

§ 85. **Roberts' Parallel Motion.**—In *Roberts' motion* (Fig. 121) the levers,  $P_1B$  and  $P_2D$ , are equal, and in the mean position of the mechanism the coupler,  $BD$ , is parallel to the fixed link; but, unlike *Tchebicheff's*, the levers are not crossed. The tracing point  $A$  does not lie in the coupler, but at the apex of the isosceles triangle  $BAD$ , the apex of which lies on the line of

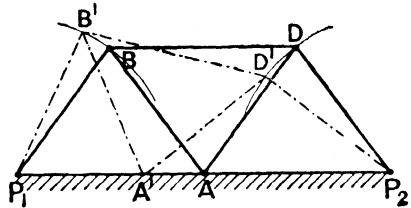

FIG. 121.

centres  $P_1P_2$ . For displacements, within limits, the point  $A$  approximately traces out the straight line  $P_1P_2$ . Moreover, if in the extreme positions of the mechanism the point  $A$  coincides with  $P_1$  and  $P_2$ , it follows that the links  $BA$  and  $AD$  must be equal in length to either of the levers, and that the coupler must be half the length of the fixed link. Also, to allow this extent of motion, the levers must not be less than a certain length, which will depend upon the length of the coupler. As a limiting case, when  $A'$  coincides with  $P_1$ , the points  $B'$ ,  $D'$ ,  $P_2$  must lie on one straight line, and the point  $D'$  will lie immediately above the mid-point of  $P_1P_2$ . Under these conditions, and

remembering that the coupler is half the length of the fixed link, it may be at once shown that the length of the levers must be 1.186 times the length of the coupler, or 0.593 times the length of the fixed link. Thus, calling the fixed link 1, the length of the coupler is 0.5, and the *minimum* length of the remaining four links 0.593. The longer, however, the length of the levers, the more accurate the motion.

§ 86. **Watt's Parallel Motion.**—By far the most important of the approximate parallel motions, consisting of four turning pairs, is that due to *Watt*. In Watt's parallel motion the levers are unequal, and, in the mean position of the mechanism, are usually

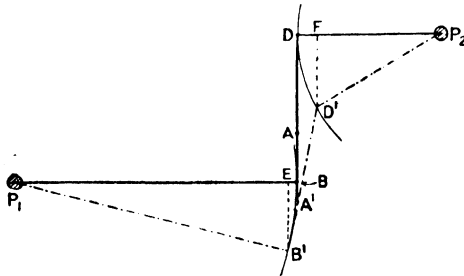

FIG. 122.

parallel. It will be assumed, in the first place, that in this position of the mechanism the coupler is perpendicular to each of the levers, so that in the mean position the mechanism is represented by  $P_1BDP_2$  (Fig. 122). After a slight displacement, the mechanism will occupy some such position as  $P_1B'D'P_2$ .

One extremity,  $B'$ , of the coupler has moved to the left, and the other extremity,  $D'$ , to the right, of the line  $BD$ ; and there is some point in the coupler which has neither moved to the right nor to the left. Let  $DB$  be produced to meet  $D'B'$  in  $A'$ , so that for the displaced position of the mechanism shown, the point  $A$  is the point in the coupler which has neither moved to the right nor to the left. The question arises whether the point  $A'$  is the same point in the coupler for different displaced positions of the mechanism; and

for this to be the case, it must be proved that the ratio  $\frac{B'A'}{A'D'}$  is the same for all positions of the mechanism, within limits. Now, if  $B'E$ ,  $D'F$  be drawn perpendicularly to the mean position of the levers,

$$\frac{B'A'}{A'D'} = \frac{EB}{DF} = \frac{\frac{EB^2}{2P_1B}}{\frac{FD^2}{2P_2D}}$$

very approximately, since the segments EB and DF are, for small displacements, small compared to the radii P<sub>1</sub>B and DP<sub>2</sub>.<sup>1</sup> Again, for sufficiently small displacements, the obliquity of B'D' to the vertical is so small that the vertical descent of every point in B'D' may be taken to be the same, in which case B'E will be sensibly equal to D'F. Hence—

$$\frac{B'A'}{A'D'} = \frac{P_2D}{P_1B}$$

The ratio  $\frac{B'A'}{A'D'}$  is therefore constant, and a pencil attached to the coupler at A' will lie in the vertical line BD for all positions of the mechanism, provided the displacement from the mean position—either above or below—is not too great. Thus, *the tracing point divides the coupler into segments which are inversely as the lengths of the nearest radius rods.*

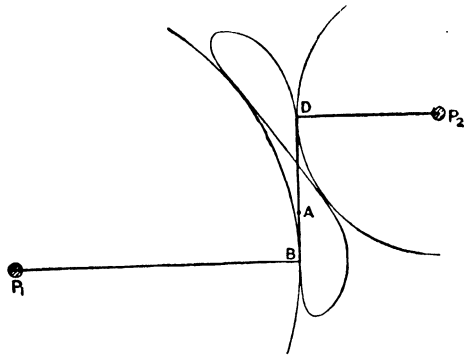

FIG. 123.

If the locus of the point A be traced out for all possible positions of the mechanism, the figure shown in Fig. 123 is obtained. One radius rod is taken double the length of the other, so that the tracing point, by the above rule, must trisect the coupler. It will

<sup>1</sup> Strictly—

$$EB(P_1E + P_1B) = EB^2$$

$$\text{and } DF(P_2F + P_2D) = FD^2$$

obtained by completing the circles of centres P<sub>1</sub> and P<sub>2</sub> and radii P<sub>1</sub>B, P<sub>2</sub>D respectively, and equating the product of intersecting chords.

be noticed that for a range of displacement of A at least equal to the length of the coupler, the locus of A is practically the line BD.

In Fig. 122 it has been assumed that the centres of oscillation of the levers lie on opposite sides of the coupler. This is the usual

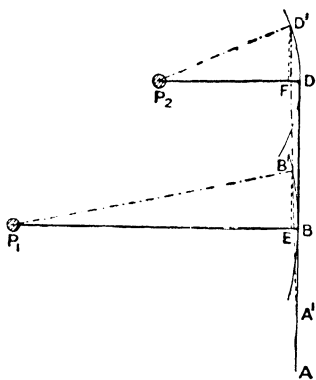

FIG. 124.

arrangement, but it can be readily modified in order to make the centres of oscillation lie on the same side of the coupler. Thus, in Fig. 124, P<sub>1</sub> and P<sub>2</sub> are the fixed centres, and DB the coupler; and in the mean position of the mechanism the coupler, as before, is taken to be perpendicular to either lever. In a displaced position, the point D' moves off further to the left than the point B', so that some point, A', in D'B' produced lies in the vertical line DB; and, for small displacements,

the point A' describes the vertical line DB. The proof of this statement is exactly the same as that just given, which may be repeated word for word. The point in the coupler which most nearly describes the straight line DB is given by the expression—

$$\frac{A'B'}{A'D'} = \frac{P_2D}{P_1B}$$

and the shorter lever is the further from the tracing point.

### § 87. Effect of the Obliquity of the Coupler in Watt's Motion.

**Design of Watt's Motion.**—The above rule for finding the tracing point gives the point in the coupler which most nearly traces out a straight line, the dimensions of the three links being given. The limit of oscillation may be calculated when the error of deviation, in the extreme positions, is given; but the calculation would be complex, and need not be discussed.

Now, for a given limit of oscillation, that is to say, for a given stroke of the tracing point, the error of deviation will clearly be greater the greater the obliquity of the coupler to the line of stroke in the extreme positions; and consequently it is desirable

to make the obliquity—on either side of the line traced out—as small as possible. The obliquity in the two extreme positions can obviously be reduced by giving the coupler a certain obliquity, in the opposite direction, when in the mean position, instead of making it, as in Fig. 122, perpendicular to the two levers. Clearly, therefore, the best results will be obtained by making the obliquity of the coupler in the two extreme positions equal and opposite to that in the mean position, and also by making the tracing point lie exactly in the required straight line in the two extreme and mean positions. To satisfy these conditions, the levers must be parallel to each other in the mean position of the mechanism, and the line traced out must bisect the versed sines of the extreme circular arcs described by the two levers. Thus, taking the case

where the centres of oscillation are on opposite sides of the coupler, as in Fig. 125,  $P_1b_1d_1P_2$  is the mean position, and  $P_1b_2d_2P_2$ ,  $P_1b_3d_3P_2$  the two extreme positions of the mechanism, the three positions of the tracing point, which lie on the same straight line, being  $a_1$ ,  $a_2$ , and  $a_3$ . The angle of oscillation of either lever is the same above and below the mean position; and in the two extreme positions the directions of the coupler are parallel, and are equally inclined, but opposite in direction, to the direction of the coupler in the mean position. Consequently, if  $m$  is the point where the line of stroke—produced if necessary—cuts  $P_2d_1$ , since  $d_1a_1$  is equal to  $d_2a_2$ , it follows that  $d_1m$  is equal to  $ml$ ; so that the line of stroke bisects the extreme versed sine of the upper lever. Similarly, it bisects the extreme versed sine ( $nb_1$ ) of the lower lever in the point  $q$ . Moreover, the following relationship holds, namely—

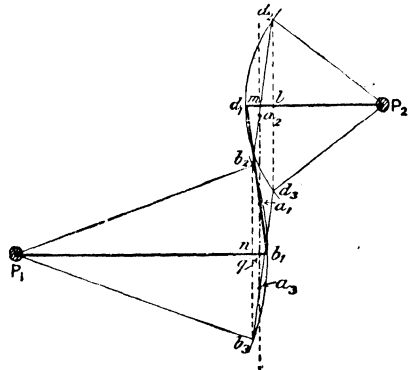

FIG. 125.

the directions of the coupler are parallel, and are equally inclined, but opposite in direction, to the direction of the coupler in the mean position. Consequently, if  $m$  is the point where the line of stroke—produced if necessary—cuts  $P_2d_1$ , since  $d_1a_1$  is equal to  $d_2a_2$ , it follows that  $d_1m$  is equal to  $ml$ ; so that the line of stroke bisects the extreme versed sine of the upper lever. Similarly, it bisects the extreme versed sine ( $nb_1$ ) of the lower lever in the point  $q$ . Moreover, the following relationship holds, namely—

$$\begin{aligned} d_1a_1 : a_1b_1 = d_1m : qb_1 = d_1l : nb_1 \\ = \frac{(ld_3)^2}{2P_2m} : \frac{(nb_3)^2}{2P_1q} \\ = P_1q : P_2m \end{aligned}$$

since  $d_2d_3, b_2b_3$  are equal and parallel. Also, the stroke of the tracing point is  $a_2a_3$ , and is therefore equal to either  $d_2d_3$  or  $b_2b_3$ ; that is to say, to  $2 \cdot ld_3$  or  $2 \cdot nb_3$ ; that is to say, to  $2\sqrt{2} \cdot \sqrt{P_2m \times d_1l}$  or  $2\sqrt{2} \cdot \sqrt{P_1q \times nb_1}$ . Hence, if  $s$  be the stroke—

$$d_1l = \frac{s^2}{8 \cdot P_2m}, \text{ and } nb_1 = \frac{s^2}{8 \cdot P_1q}$$

These relationships enable many problems connected with the setting out of these parallel motions to be solved geometrically. One problem only need be considered.

Suppose that the length of the stroke, the line of stroke, the mean position of the tracing point, the position of one of the fixed centres, and the distance between the centre lines of the levers when in the mean position are given. Required to find the lengths

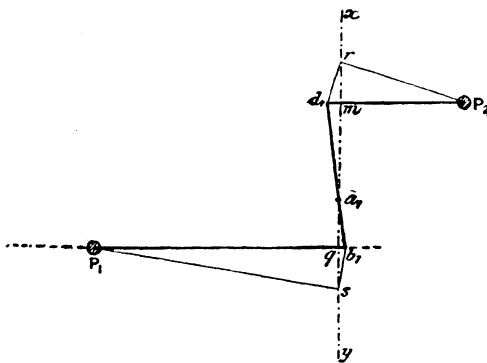

FIG. 126.

of the levers and coupler, and also the position of the second centre.

Let  $P_2$  (Fig. 126) be the known centre,  $xy$  the line of stroke,  $a_1$  the mean position of the tracing point, and the line through  $P_1$  (as yet unknown) the line on which the second centre lies. Draw a line

through  $P_2$  perpendicular to the line of stroke to meet it in  $m$ , and mark off  $mr$  equal to one-quarter the stroke ( $s$ ). Join  $P_2r$ , and draw  $rd_1$  perpendicular to it to meet  $P_2m$  in  $d_1$ . Then  $d_1m$  is clearly equal to  $\frac{s^2}{16 \cdot P_2m}$ , and is therefore half the versed sine, and consequently  $P_2d_1$  is the length of the first lever. The direction of the coupler

in the mean position is then obtained by joining  $d_1, a_1$ ; and by producing it to  $b_1$ , the extremity of the second lever is obtained. To find the centre of the second lever, draw  $qs$  equal to one-quarter of the stroke, join  $b_1s$ , and draw  $sP_1$  perpendicular to it. Then  $P_1$  is the position of the centre of oscillation of the second lever, and the length of that lever is  $P_1b_1$ , the length of the coupler being, of course, equal to  $b_1d_1$ . The proportions thus obtained satisfy the given data. In the mean and two extreme positions the tracing point  $a$  lies exactly on the straight line  $xy$ ; in intermediate positions there will be a slight deviation from the straight line, but it will usually be so slight as to be quite inappreciable. The extent of the deviation, and other problems connected with Watt's parallel motion, will be found discussed in Rankine's "Machinery and Millwork," §§ 252-255 of the first edition.

§ 88. **The Pantograph.**—The preceding mechanisms, consisting entirely of turning pairs, show how a straight line may be exactly or very approximately generated. Scott-Russell's motion is an illustration of a copying machine, the accuracy of the line traced out depending upon the accuracy of the line copied, and it only truly describes a straight line provided the initial line is perfectly straight. A true copying machine is one which exactly reproduces the motion of the tracing point on a different or on the same scale, all the irregularities in the original being reproduced in the copy. As copying mechanisms are very frequently associated with parallel motions, it will be advisable, at this stage, to consider them.

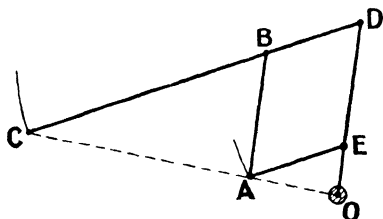

Fig. 127.

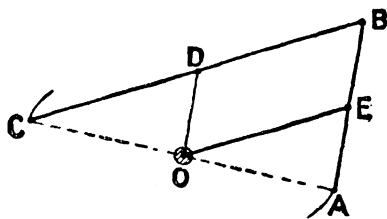

Fig. 128.

The most familiar copying mechanism is the *pantograph*, which may exist in various forms, such, for example, as are shown in Figs. 127 to 130. In each of the first three figures there are four

links, which form a parallelogram; and if the proportions are such that the points O, A, and C are collinear in one position, they are collinear in all positions of the mechanism. In each figure, O is a fixed centre, and the point C traces out a curve exactly similar to that traced out by A, whatever the shape of that curve may be. This follows from the fact that the ratio of the radii from the fixed point O to the loci of C and A is always constant and equal to  $\frac{OC}{OA}$ , that is to say, to  $\frac{DC}{DB}$ . In Fig. 128, if D and E are the middle points of BC and BA respectively, the curve traced out by C will be exactly the same size as that traced out by A. In Fig. 130 the links CG, CE are parallel to AH, AF respectively.

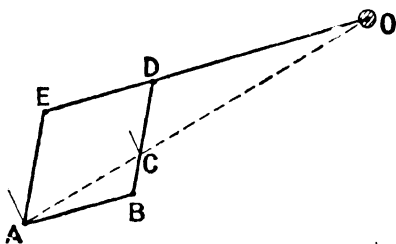

FIG. 129.

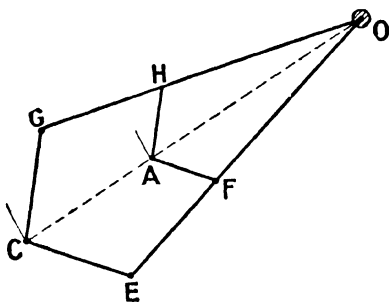

FIG. 130.

The pantograph mechanism is employed to determine the section of steel rails, tyres, and similar bodies, and in engraving machines, beam engines, indicators, etc. A few applications will be noticed in detail.

§ 89. **Determination of the Section of Rails, etc.**—A convenient arrangement for recording the profile of tyres, rails, etc., is shown in Figs. 131, 132,<sup>1</sup> in which the pantograph has equal arms, so that the points A and C describe reversed figures of exactly the same size. The arm BC terminates in a pin and socket, on which may be clamped, in any position, a bent piece, which carries a small hard steel-pointed pin threaded for accurate adjustment, the axis of the pin being set at an angle of about 55 degrees with the arm BC.

<sup>1</sup> *Engineering*, July 20, 1900.

At the end A of the rod AB is fixed a pencil, with which the movements of the pointer C can be reproduced on a sheet of paper attached to a board, the board being clamped to a prolongation of the upper part of the frame. The tyre or rail is attached by means

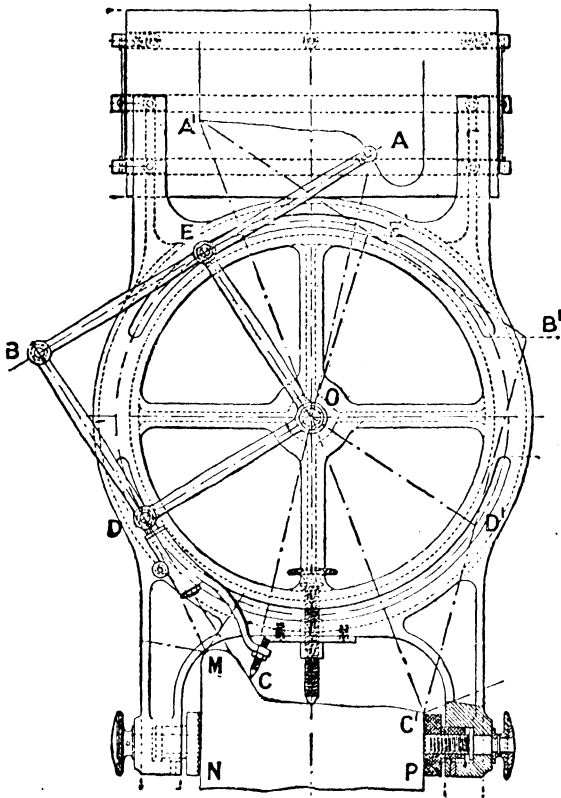

FIG. 131.

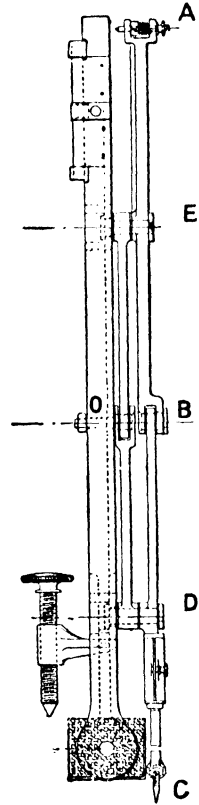

FIG. 132.

of set screws to a prolongation of the lower part of the frame, and the instrument must be carefully adjusted with respect to the wheel or rail, so that the plane of the pantograph coincides with a true cross-section of the tyre or rail, otherwise a distorted section is obtained. With the mechanism arranged as shown in the figure, the traverse of the pointer extends from M to C'; and when the

highest point has been reached, the lower part of the arm BC is turned on the pin and socket, which throws the angled pointer into such a position that the vertical part of the profile as far as N can be traced. When this has been done, the pencil at A is raised, and the whole system shifted over into the position A'B'C'; the pointer is then turned again, and the vertical line C'P may be drawn.

§ 90. **The Beam Engine.**—In beam engines, the crank shaft L is driven from the piston rod GA, through an oscillating beam, EN, and connecting rod, NM; and the pumps also are usually driven from the same beam, the arrangement being as shown in Fig. 133. The upper extremities of the pump and piston rods have to be connected to the oscillating beam in such a manner that they are constrained to move

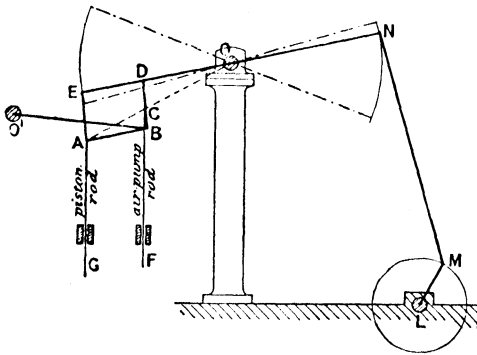

FIG. 133.

in vertical straight lines. The arrangement adopted is to constrain the upper extremity of the pump rod to describe a straight line by means of Watt's parallel motion, and to make the upper extremity of the piston rod copy that straight line by means of a pantograph. Thus, OE is one arm of the walking beam of the engine, which turns about the main centre, O; and EA is the main link which connects the upper extremity A of the piston rod AG to the walking beam. The links AB, BD, DE, and EA form a parallelogram, the link DB being called the back-link, and BA the parallel bar. The piston-rod head A is to be guided so that its highest, middle, and lowest positions shall be in one straight line; and this is effected by guiding in a straight line the point C. The point C is guided in its straight line by means of a bridle-bar, BO', turning about an axis at O', so that ODBO' forms a Watt's parallel motion. Usually a pump rod is hung from

C; so that if the proportions of the parallel motion be such that the point C lies in a vertical straight line in the highest, middle, and lowest positions of the pump plunger, the proportions of the pantograph may be made such that the point A satisfies the same conditions for the piston rod. The parallel motion may be accurately designed by the methods given in § 87; but if it be assumed that the back link is perpendicular to the walking beam and bridle rod in the mean position of the mechanism, an expression may be readily obtained for the length of the bridle rod in terms of the length of the walking beam and the strokes of the piston and pump plunger. Thus, the back link must be divided into segments which satisfy the condition—

$$O'B = OD \cdot \frac{DC}{CB};$$

whence, by the geometry of the mechanism—

$$\begin{aligned} O'B &= OE \cdot \frac{DC}{CB} \cdot \frac{DC}{AE} = OE \cdot \frac{DC^2}{AE(AE - DC)} \\ &= OE \cdot \frac{OC^2}{OA(OA - OC)} \end{aligned}$$

But  $\frac{OC}{OA}$  is the ratio of the strokes of the air-pump and piston rods; whence if  $s_1$  and  $s_2$  be the two strokes respectively, and  $2l$  be the length of the walking beam, the length of the bridle rod is—

$$l \cdot \frac{s_1^2}{s_2(s_2 - s_1)}$$

§ 91. **Steam-engine Indicators.**—The pantograph is also very commonly applied to steam-engine indicators. A sectional view of a steam-engine indicator is shown in Fig. 134. In an indicator, the steam-pressure is measured by the extension or compression of a helical or other form of spring, one end of which is attached to the piston of the indicator, and the other to the cap of the indicator cylinder, so that the displacement of the extremity of the indicator piston-rod measures the pressure. The link

mechanism magnifies this displacement—the usual magnification being from four to six times—and the conditions that have to be

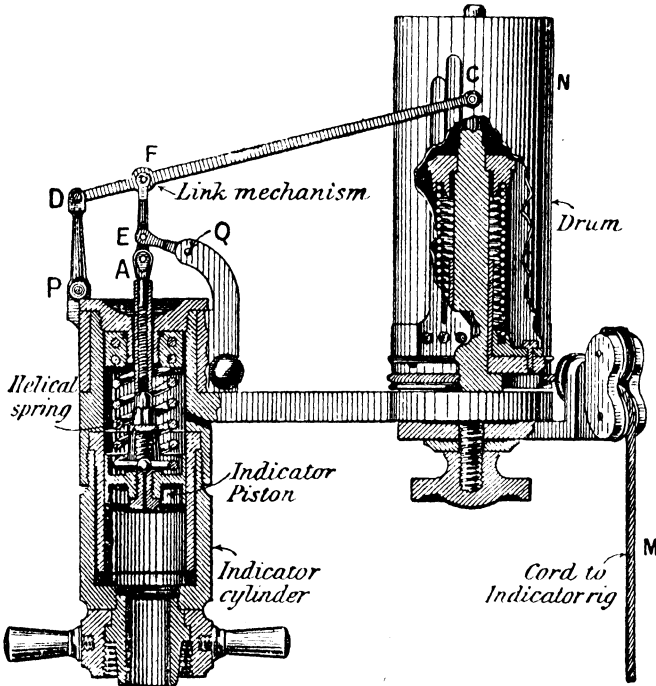

FIG. 134

satisfied are that the tracing pencil must move in a straight line parallel to the axis of the indicator cylinder, and that its displacement must always be exactly proportional to the displacement of the indicator piston.

§ 92. **Simplex Indicator.**—One method of satisfying these conditions is to assume that the piston rod is effectually guided in a straight line by contact of the piston and rod with the indicator cylinder, and to simply magnify the motion of the extremity of the piston rod by the use of the pantograph. This method is adopted in the *Simplex* indicator, shown in Fig. 135, in which the spring is outside the cylinder (instead of being inside, as shown in Fig. 134), and

is of sugar-tong shape. The fixed centre of the pantograph is O, the point of attachment to the indicator rod is A, and the tracing point is at C; and the point C faithfully reproduces the motion of A. In order to reduce the frictional forces to a minimum, the piston and rod may be made comparatively loose fits in the cylinder and cap; with the result that the point A may have a slight lateral motion. The pencil C would reproduce this lateral displacement on an enlarged scale, and the indicator card would be distorted. When, therefore, any slackness in fit is allowed, the pencil is usually guided in its straight-line path by a parallel motion which is independent of the piston rod; and the proportions of the motion must be such that the pencil exactly lies on the required straight line in the extreme and mean positions of the mechanism.

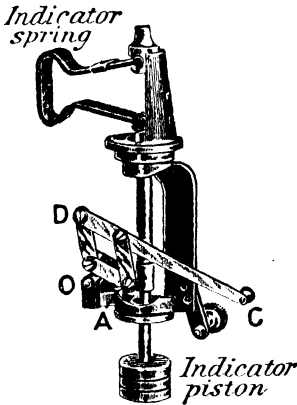

FIG. 135.

the proportions of the motion must be such that the pencil exactly lies on the required straight line in the extreme and mean positions of the mechanism.

§ 93. Richards' Indicator.—In Richards' indicator (and also in

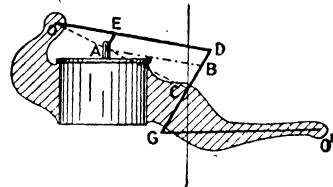

FIG. 136.

many others) the parallel motion employed is *Watt's*. In Fig. 136, A represents the extremity of the piston rod. The pencil is placed at the point C, and is compelled to trace out the required straight line by means of the parallel motion ODGO', the proportions of which may be obtained by the methods given in §§ 86, 87. The motion of A may then be made a reduced *facsimile* of the motion of C by a parallelogram of links DEAB, which form a pantograph. By this means the point A is subjected to two independent constraints, namely, the constraint due to the pantograph, and also that due to the guidance which the rod receives from the cylinder. Probably, to prevent any chance of jamming, the link AB in the

pantograph is usually omitted. In addition to this advantage, the number of pin joints and links is reduced by unity, and so the friction and mass of the moving linkwork are also reduced—considerations which are of considerable importance.

§ 94. *Thompson Indicator*.—In the *Thompson* indicator (Fig. 137), the arrangement is somewhat similar to the above, but the parallel motion is of the grasshopper type. The two oscillating levers of the parallel motion are  $RB$  and  $QD$  (compare Fig. 118), and the coupler is  $BD$ , the tracing pencil being at  $A$ . The parallel motion may be designed as in § 83. Provided the extreme and mean positions of  $A$ , together with the lengths of the links  $RB$ ,  $BA$ ,

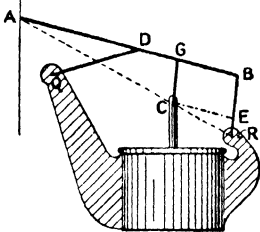

FIG. 137.

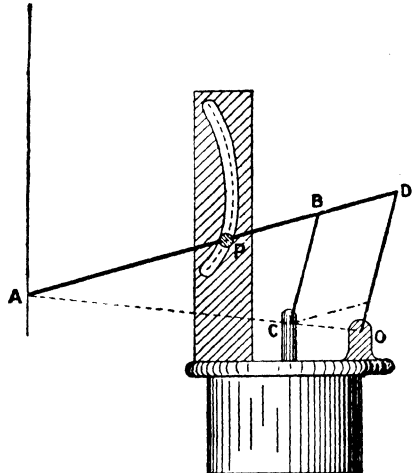

FIG. 138.

and  $DA$ , are known, the three corresponding positions of the point  $D$  can be plotted, and so the length of the radius  $QD$  and the position of the centre  $Q$  obtained. The extremity  $C$  of the rod may be made to copy the motion of  $A$  by the parallelogram of links  $GBEC$ ; but, as before, the link  $CE$  is usually omitted.

§ 95. *Tabor Indicator*.—In some indicators the pencil is made to move in a straight line by constraining some other point to move in a definite path by means of an actual envelope. For example, suppose that the faint vertical line (Fig. 138) represents the straight line which has to be traced out by the pencil  $A$ , and that  $OD$  is a link turning about the fixed centre  $O$ . As  $A$  moves in its straight-line path, any point, such as  $P$ , in  $AD$  will trace out

a certain curve, which can be readily plotted; and if a pin, placed at P, be constrained to move along this curved path, the point A will describe a straight line. This method is adopted in the *Tabor* indicator illustrated in Fig. 138. The pantograph has, as before, one link missing. It will be noticed that this mechanism has only three links and four pin joints, in addition to the roller pin at P.

§ 96. Crosby Indicator.—As a final illustration of the link mechanism of an indicator, consider the Crosby indicator illustrated in Fig. 134. In this indicator the pantograph is not used, and the

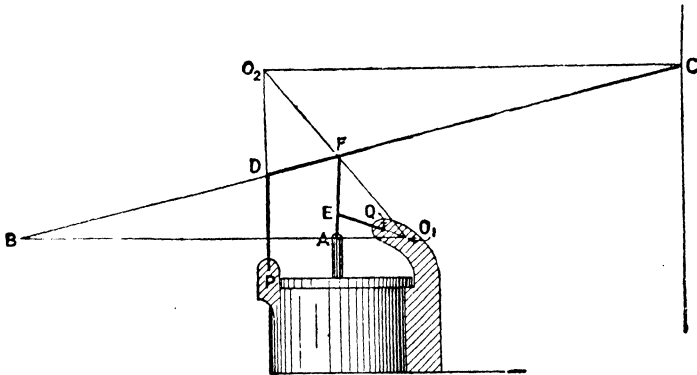

FIG. 139.

accuracy with which the pencil traces out its straight line depends upon the motion of the piston rod; in other words, the pencil is not constrained to move in a straight line independently of the piston rod. Under these conditions, the simplest mechanism to employ is the pantograph, as in the Simplex indicator (Fig. 135); but the mechanism of the Crosby indicator is reproduced in Fig. 139. In that diagram P and Q are fixed centres of oscillation of the levers PD and QE, the extremity of the piston rod being A, and the position of the pencil being C. The design of the linkwork is not very simple, but it is clear that if the lengths of all the links be given, and the point A in the link FE produced be definitely guided in a straight line by the indicator cylinder, then the pencil C in the link DF produced is definitely constrained to move along a certain

path.<sup>1</sup> The proportions of the mechanism must be such that the path of C is, very approximately, a straight line; and also that the velocity ratio of the points C and A is sensibly the same for all positions of the mechanism. Perhaps the best way of designing the mechanism is as follows: Let the straight lines which have to be traced out by A and C be given, and plot A and C in their extreme and mean positions. Moreover, assume that the lengths of the links CF and FA are known (in the mean position, CF ought to be approximately horizontal, and FA approximately vertical), and also that the positions of the points D and E in CF and FA respectively are given. The positions of the points D and E, corresponding to the extreme and mean positions of the mechanism, may then be plotted, and the position of the centre Q may be obtained by finding the centre of the circle which passes through the three positions of E. The locus of D is then found, and approximated to by drawing a circular arc, when these give the lever PD. We thus satisfy the conditions that the pencil lies in the required straight line in its extreme and mean positions, and that when the piston has moved through half its range, so likewise has the pencil. In any intermediate position the pencil will probably not exactly lie on the required straight line, neither need the velocity ratio of the pencil and piston be strictly constant; and the extent of the errors will depend on the lengths of the links which are assumed.

If the proportions of the mechanism have been obtained, their accuracy might be verified for any position in the following manner:<sup>2</sup> Assuming the point A to move in a true straight line, the instantaneous centre of the link AF is clearly the point  $O_1$ , where EQ produced intersects the perpendicular through A to the line of stroke. The point F, therefore, in the link CD is moving perpendicularly to  $O_1F$ , and consequently, since the point D is moving perpendicularly to PD, the instantaneous centre of FD is the point  $O_2$ . Every point in the link DF is rotating about  $O_2$ , and there-

<sup>1</sup> By the method described in § 9, there are five pairs and six elements.

<sup>2</sup> This argument cannot be read at the first reading, because it involves a knowledge of the method of instantaneous centres, which is discussed in the next chapter.

fore, at the instant considered, the point C is moving perpendicularly to  $O_2C$ . Since C has to move, very approximately, in a vertical straight line, it follows that the line  $O_2C$  must be sensibly horizontal in all positions of the mechanism. If the proportions of the mechanism are such that this condition is satisfied, the velocity ratio of C to A may be readily obtained. Thus, if  $v$  denote velocity, and suffixes refer to the different points—

$$\frac{v_c}{v_a} = \frac{O_2C}{O_2F} \text{ and } \frac{v_f}{v_a} = \frac{O_1F}{O_1A}$$

whence—

$$\frac{v_c}{v_a} = \frac{O_2C}{O_2F} \cdot \frac{O_1F}{O_1A} = \frac{O_1B}{O_1F} \cdot \frac{O_1F}{O_1A} = \frac{O_1B}{O_1A}$$

where B is the point in which  $O_1A$  produced intersects the link DC. This ratio must be sensibly constant for all positions of the mechanism; otherwise the displacement of C would not be proportional to the piston pressure. In indicators using the pantograph principle, the constancy of the velocity ratio is directly assured.

§ 97. **Indicator Rigs.**—A subject closely allied to the parallel motions of indicators is that of indicator rigs. In an indicator, not only has the steam-pressure to be recorded on a sufficiently large scale, but the position of the engine piston must also be recorded. This is effected by making the pencil trace out a curve on a sheet of paper attached to an oscillating drum, N (see Fig. 134 which represents the Crosby indicator), the angle turned through by the drum being proportional, on some scale, to the displacement of the engine piston from the end of the stroke. A cord or wire, M, is wrapped round the drum, and is led over guide pulleys to some point in a mechanism the object of which is to reproduce, on a reduced scale, the motion of the engine piston or crosshead. The return motion of the drum is obtained by a spring inside the drum. The reducing mechanism is very frequently known as the *indicator rig*.

The degree of accuracy required in reproducing the displacement of the engine piston need not be so great as that required in recording the steam-pressure. The primary condition that has to be satisfied in indicator rigs is, that the displacement of the point

of attachment of the cord or wire parallel to the stroke of the engine piston must be exactly, or very nearly exactly, proportional to the displacement of the piston, any slight displacement perpendicular to the stroke having only a secondary effect on the motion of the drum, the error introduced being due to the varying obliquity of the cord. As the length of the cord or wire is usually very long compared to the displacement of the point of attachment perpendicular to the stroke, the cord remains sensibly parallel, and the motion of the drum differs almost inappreciably from the motion of the point of attachment in a direction parallel to the stroke.

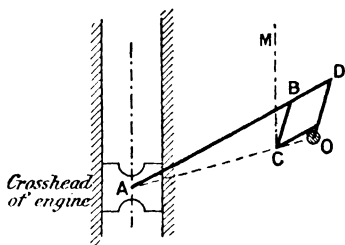

FIG. 140.

The more familiar indicator rigs are shown in Figs. 140 to 146. In Fig. 140, the point of attachment of the cord C is made to exactly copy the displacement of the crosshead A by means of the pantograph; so that the motion of the drum, neglecting the stretching of the cord, is mathematically exact. Another device, which reproduces accurately the motion of the crosshead (neglecting any slipping or stretching of the cord), is shown in Fig. 141,

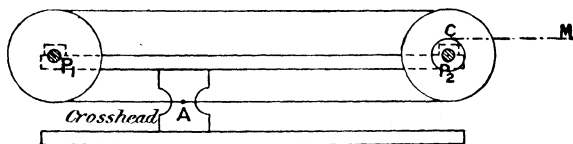

FIG. 141.

in which two equal pulleys, rotating about pins  $P_1$ ,  $P_2$  attached to the guide-bar of the crosshead, are connected by an endless cord which is attached to the pin A. The cord CM is taken from a smaller pulley compound with the pulley turning about the pin  $P_2$ .

Again, in Fig. 142, P is a fixed centre lying exactly in the line of stroke, and the links PB and AB are of equal length. The displacement of C parallel to the stroke is exactly proportional to the displacement of the crosshead; but the actual locus of the

point C is an arc of an ellipse, and thus the obliquity of the cord varies slightly. That the locus of C is an ellipse is seen by producing AB to D, and making BD equal to either AB or PB, in which case D will describe a straight line perpendicular to the stroke, and any other point in AD, such as C, describes an ellipse.

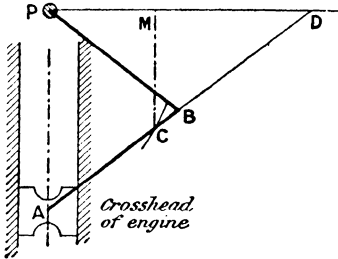

FIG. 142.

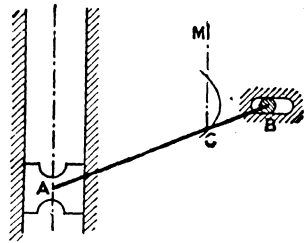

FIG. 143.

A precisely identical arrangement is shown in Fig. 143, in which the link PB is dispensed with, and the point B actually constrained to move in a slot, the slot being perpendicular to the stroke and opposite the mean position of the piston; the ratio of reduction being  $\frac{BC}{BA}$ . Figs. 142, 143 are therefore examples of a rig which

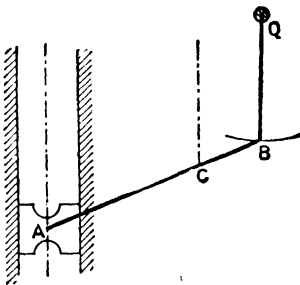

FIG. 144.

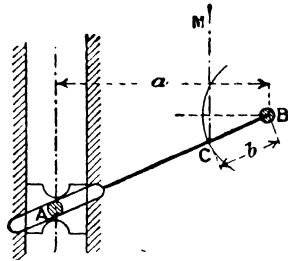

FIG. 145.

are mathematically accurate in the line of stroke, but in which there is a slight error in the displacement of the drum due to the varying obliquity of the cord.

Fig. 144 is a modification of Fig. 143, in which the slot is replaced by a lever, QB, so that the locus of B is a circular arc

instead of a straight line. The motion of the point of attachment C is now not exact in the line of stroke, and, in addition, there is still the slight error due to the varying obliquity of the cord.

Fig. 145 is a modification of Fig. 144, in which the fixed slot is replaced by a slot at the crosshead end of a lever which oscillates about the fixed centre B. The locus of the point of attachment C is a circular arc of centre B, and the displacement ratio of C and A parallel to the stroke is no longer constant; and, in addition, the varying obliquity of the cord introduces a slight error. Reckoned from the mean position of the piston, the displacement of the drum parallel to the line of stroke (neglecting the error due to obliquity) is  $b \sin \theta$ , and of the piston is  $a \tan \theta$ ; where  $b$  is the length of BC,  $a$  the perpendicular distance of B from the line of stroke, and  $\theta$  the angle which AB makes with its mean, or horizontal, position. The velocity ratio of the drum and piston is, therefore,  $\frac{\delta(b \sin \theta)}{\delta(a \tan \theta)} = \frac{b}{a} \cos^3 \theta$ , which is not independent of  $\theta$ , and is, consequently, not constant. Thus the rig represented in Fig. 143 is more accurate than that represented in Fig. 145.

Fig. 146 is similar to Fig. 145, with the exception that the cord is wrapped round a circular wheel attached to the lever. There is, therefore, no obliquity error, and the velocity ratio of the drum and

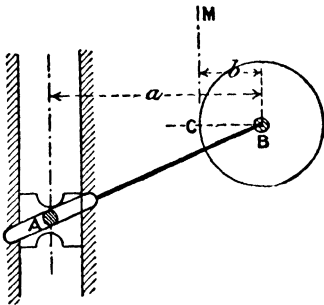

FIG. 146.

piston is  $\frac{\delta(b\theta)}{\delta(a \tan \theta)}$ , that is,  $\frac{b}{a} \cos^2 \theta$ ,  $b$  being the radius of the wheel. For a given value of  $\theta$ , the variable coefficient,  $\cos^2 \theta$ , is more nearly equal to unity than the coefficient  $\cos^3 \theta$  in the previous case, and thus the arrangement of Fig. 146 is more accurate than that of Fig. 145.

§ 98. **Davis' Steering Gear for Motor-cars.**—In parallel motions, some point in one of the links either approximately or exactly describes a straight line. In the mechanism about to be described a straight line is likewise traced out, but the straight line is not

the locus of some particular point, but of the point of intersection of two links of the mechanism.

In an ordinary vehicle the fore carriage is usually pivoted to the rest of the frame, and the two front wheels rotate loosely on one axle attached to the fore carriage. When running on a curved path, the common axis of the two front wheels will always intersect the back axle, and sharp corners can consequently be turned with ease and safety. In motor vehicles, the driving axle is almost invariably the rear axle, and there is no pivoted fore carriage. The two front wheels rotate freely on different axles, and these axles can be turned, in a horizontal plane, through certain angles by some kind of mechanism. In order to take sharp corners at high speeds with ease and safety, the condition that has to be satisfied is that the axes of the two front wheels should intersect the rear axle in the same point; but the axes may be at different heights. In the majority of cases this condition is only approximately satisfied, but in *Davis' steering gear* it is exactly fulfilled.

A sketch of this steering gear is shown in Fig. 147. In that figure, A represents the frame of the machine, and E and F the

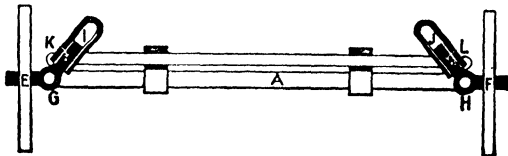

FIG. 147.

two front wheels, which rotate loosely upon the axles GE, HF, pivoted about vertical pins at G and H. These two axles can be rotated about the spindles G and H by means of the bell-cranked levers EGI and FHJ respectively, the arms GI and HJ carrying hollow sliding pieces which are connected by the link KL. The link KL is constrained to slide in guides in a direction parallel to GH, so that by pushing this link over, the wheel axles can be turned through any required angles. The thick lines (Fig. 148) represent the mean position, and the faint lines any displaced position of the mechanism. In the mean position the arms GI, HJ intersect in R; in the displaced position they intersect in S. The two axles

will be in the same straight line when the car is running on a straight course, and will intersect in some point, T, when running round a curve. The mechanism is such that the locus of the point T may be made to coincide with the axis of the driving axle.

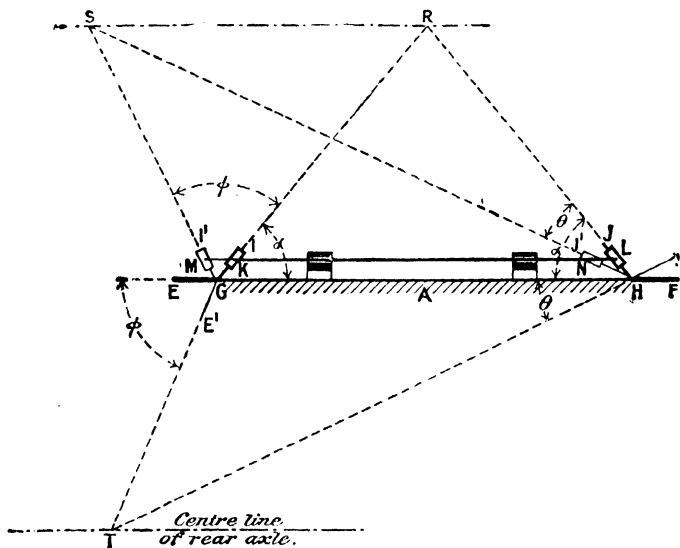

FIG. 148.

To prove this statement, since MN is parallel to GH and equal to KL,—

$$\frac{SM}{SG} = \frac{MN}{GH} = \frac{KL}{GH} = \text{constant}$$

$$\text{and therefore } \frac{GM}{GS} \text{ is constant;}$$

whence, since G is a fixed centre, and the locus of M is the line KL parallel to GH, it at once follows that the locus of S is also a straight line parallel to GH. In other words, the locus of the point of intersection of the arms GI and HJ is the straight line through R parallel to GH; consequently, the triangles GSR and HSR, being between the same parallels and having the same base, are of equal area. But the area of the triangle SGR is  $GR \times \frac{1}{2}SG \sin \phi$ ,

and of the triangle HSR is  $RH \times \frac{1}{2}SH \sin \theta$ , where  $\phi$  and  $\theta$  are the angular displacements of the bell-crank levers from their mean positions; whence, since  $GR = HR$ ,

$$\frac{\sin \phi}{\sin \theta} = \frac{SH}{SG}$$

$$\text{But } \frac{SH}{SG} = \frac{\sin SGH}{\sin SHG} = \frac{\sin(\phi + \alpha)}{\sin(\alpha - \theta)}$$

where  $\alpha$  represents either of the angles  $RGH$  or  $RHG$ ; therefore—

$$\frac{\sin \phi}{\sin \theta} = \frac{\sin(\phi + \alpha)}{\sin(\alpha - \theta)}$$

Expanding and transposing, we get—

$$\frac{1}{2} \tan \alpha (\cot \theta - \cot \phi) = 1$$

Since the angles  $EGT$ ,  $GHT$  are respectively equal to  $\phi$  and  $\theta$ , this equation at once reduces to

$$\frac{1}{2} \cdot \frac{2p_1}{GH} \cdot \frac{GH}{p_2} = 1$$

in which  $p_1, p_2$  are the perpendicular distances of  $R$  and  $T$  from  $GH$ ; whence  $p_1 = p_2$ . Thus the distance of  $T$  behind the line of centres  $GH$  is always equal to the distance of  $R$  in front of it. If, therefore, the angle  $\alpha$  is made such that the point  $R$  is as much in front of the line of centres  $GH$  as the back axle is behind it, it follows that the locus of  $T$  coincides with the axis of the back axle. Consequently the axles  $GE'$  and  $HF'$  will always intersect in the back axle, and the car can run in a curved path with perfect ease and safety. The front wheels can run at different speeds to suit the curvature of the path, because they rotate loosely upon their axles; and the back wheels can rotate at different speeds, because the back axle is made in two parts, which are connected together by a differential gearing. This gearing has been already described in § 71.

§ 99. **Oldham's Coupling. Elliptic Chuck.**—It will be noticed that the mechanism of Davis' steering gear virtually consists of a

duplication of the double-slider crank chain, the turning pairs being at G and K, and the elements of the sliding pairs being the frame and KL, and the lever GI and the block K. Another mechanism consisting of the double-slider crank chain, which is used on account of its geometrical property, is the *elliptic chuck*.

With an ordinary carrier or jaw chuck, screwed on to the headstock mandrel of the lathe, the tool turns the work into a truly cylindrical form; when the elliptic chuck is used, the bar is turned up to an elliptic section.

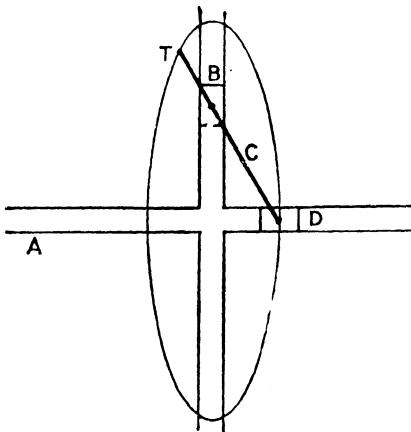

FIG. 149.

To clearly understand the principle of the elliptic chuck, it will be well to refer to the simplest form of the double-slider crank chain, namely, the elliptical trammels (Fig. 149). The two blocks B and D are constrained to move in straight-line paths by contact with the link A, and they are connected together by a link C of invariable

length. Under these conditions, any point, T, in DB or in DB produced describes an ellipse on a sheet of cardboard attached to A, the semi-axes of the ellipse being DT and BT respectively. Moreover, as already pointed out in § 7, the curve which T describes on the cardboard attached to A will be the same under all conditions—that is to say, whichever link is fixed. In particular, if the link C is fixed, and the blocks B and D allowed to rotate about fixed centres, so that the rotation is transmitted between them by the connecting link A, then the pencil at T (which will now be stationary) will describe on the sheet of cardboard attached to A exactly the same ellipse as before; and if a cutting tool, instead of a pencil, be attached to the link BD at T, a piece of cardboard of truly elliptic shape would be cut out. The most familiar mechanism consisting of this chain, in which the

link C is fixed, is Oldham's coupling, which is primarily used to transmit a constant velocity ratio between two parallel shafts which are not in the same line (§ 139); but it can also be used—slightly modified constructively—to turn out bars of elliptic section. A longitudinal and end elevation of Oldham's coupling is shown in Figs. 150, 151. The frame is represented by C, the rotating shafts by B and D, and the connecting link by A, the latter having two perpendicular projections, one on each side of the disc, which slide in corresponding grooves formed in discs keyed to the shafts. If a cutting tool, T, be rigidly attached to the frame C, so that the cutting edge is in the same plane as the

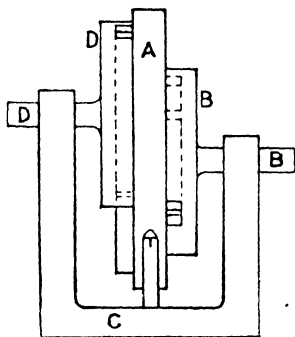

FIG. 150.

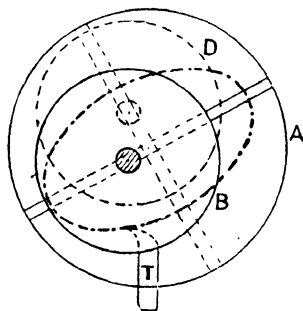

FIG. 151.

axes of the two shafts, then, as the motion is transmitted from B to D, the tool T will turn the plate A into a truly elliptical shape, shown by the chain-broken curve in the end elevation. The only difference between the elliptic chuck and the arrangement of Fig. 150 is that, in the elliptic chuck, the two shafts are placed on the same side of A, so that A, instead of lying between the two discs B and D, overhangs them.

A diagrammatic sketch of a practicable arrangement as applied to a lathe is shown in Fig. 152. The headstock of the lathe is represented by C, and the headstock spindle by B. To the headstock spindle is screwed a rectangular piece, *b*, and to the headstock frame is attached a complete ring, *c*, by means of the set-screws S, S, the ring being turned up truly cylindrical, and its axis being the line *c'*. The link D is in the form of a circular strap

sliding over the fixed ring  $c$ , and has cast with it two rectangular lugs,  $d, d$ , which project outwards. The plate  $A$  has two grooves—the centre lines of which are perpendicular to each other—cut into it; and the block  $b$  fits into one of these grooves, and the lugs  $d, d$  into the other. The carrier, or jaw chuck, is attached to  $A$  in the same manner as it is usually attached to the mandrel. The

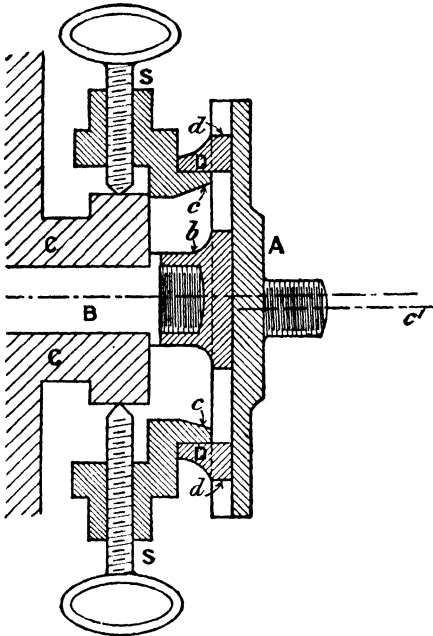

FIG. 152.

arrangement is kinematically identical with Oldham's coupling, and if a cutting tool be attached to the slide rest so that its cutting edge is in the plane of the axes  $B$  and  $c'$ , and the lathe be worked in the ordinary way, the tool will turn up a truly elliptical bar. The dimensions of the bar turned up can be varied within the limits of capacity of the lathe; but the difference between the lengths of the major and minor axes of the ellipse is always equal to twice the distance between the axes  $B$  and  $c'$ . This distance is varied by adjusting the set-screws  $S, S$ . If the centre lines

coincide, the chuck behaves as an ordinary chuck, and the work is turned up truly cylindrical.

§ 100. **Machines for drilling Elliptic Holes in Flat Plates. Slotting Machines.**—The elliptical trammel is kinematically equivalent to a pair of circular wheels gearing internally, one wheel having twice the diameter of the other. Thus, suppose that  $A$  (Fig. 153) is a fixed annular wheel, and  $C$  a wheel of half the diameter gearing internally with it, the wheel  $C$  being free to turn on a pin,  $e$ , carried at the extremity of an arm,  $ac$ , which turns

about the centre  $a$  of the wheel A. It is well known (§ 68) that if the wheel C roll round inside A without slipping, any point in the circumference of C will trace out a diameter of A, and that the two extremities B and D of the diameter BD will trace out perpendicular diameters. The mechanism is therefore kinematically equivalent to that represented in Fig. 149, the only difference being that, instead of the points B and D being constrained to move in straight-line paths by actual contact with the guides, the straight lines are generated by gearing. Consequently,

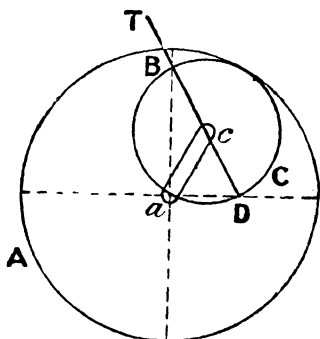

FIG. 153.

if a pencil, T, be attached to an arm fastened to the wheel C, the pencil will trace out an ellipse on the plane of A. This is equally true if both circles rotate about fixed centres, so that if we imagine the wheel A keyed to the headstock mandrel of a lathe, and to drive a wheel C, which turns about a fixed axis,  $c$ , and which carries an arm DBT; then a tool attached at T will cut out an ellipse on a body which rotates with A—that is to say, with the headstock mandrel. The only difference between this arrangement and that of an ordinary lathe is that in an ordinary lathe the tool is fixed, whilst in the present case it rotates about an axis parallel to the headstock mandrel. We could, therefore, readily devise a machine for cutting elliptical holes in flat plates, or for boring out elliptic cylinders, the plate or cylinder being attached by some means to a face plate on the headstock mandrel, and the tool fed by means of a screw in the ordinary way. For convenience of manipulating the plate or cylinder, the axes of the wheels may be placed vertically.

The cases where an elliptic cylinder has to be bored are rare, but the occasion very often arises—as in boiler-plates—when large elliptic or oval holes have to be cut out in flat plates. Machines by means of which this may be effected may either consist of a modified elliptic chuck, or by gear wheels as just described, or by

a radial drilling machine modified to suit the required purpose. A radial drilling machine has been already described and illustrated in Fig. 84. By its means, the tool can readily be adjusted in any position over the work; but, when drilling, the drill rotates about a fixed axis. If, in place of an ordinary twist drill, a radial arm be attached to the drill spindle, and a cutting tool be fastened at the end of the radial arm, then a circular hole, of any convenient size, may be cut out of a flat plate attached to the table. But suppose that, as the drill spindle rotates, the carriage L (Fig. 84) also receives a reciprocating motion on the arm F, the time of one complete reciprocation of the carriage being the same as that of a complete rotation of the cutting tool; clearly, the tool will now cut in the fixed plate an oval, instead of a circular, hole. The reciprocating motion of the carriage may be effected by the mechanism of the direct-acting engine (Fig. 1). Suppose, for example, that the arm F (Fig. 84) carries a vertical stud (not shown) which is driven from the spindle E by gearing; and that a crank arm attached to this stud is connected to the carriage L by means of a connecting rod. Suppose, moreover, that the gearing is such that the auxiliary stud rotates at the same speed as the drill spindle P; so that L, carrying the spindle P, makes one complete reciprocation in exactly the same time that the cutting tool makes one complete revolution. Let the tool, which is attached to a radial arm, be in its extreme position to, say the right, when the carriage L is also in its extreme position to the right; and let  $a$  be the length of the radial arm attached to the spindle, and  $c$  the length of the crank arm attached to the stud. Then, when the cutter arm has

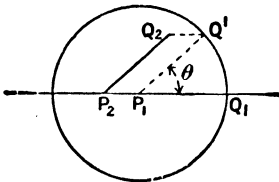

FIG. 154.

moved through an angle  $\theta$  measured from a line parallel to the direction of the arm F, so likewise has the crank arm attached to the stud. In Fig. 154,  $P_1$  represents the extreme position of the spindle, and  $Q_1$  of the cutting tool. If the spindle were fixed, the cutting tool, after an angular rotation  $\theta$  of the spindle, would be at  $Q_1'$ ; but, in the mean time, the spindle moves to  $P_2$ , so that the cutting tool is at  $Q_2$ ,

where  $P_2Q_2$ ,  $Q_1Q_2$  are drawn parallel to  $P_1Q_1$  and  $P_1P_2$  respectively. If the connecting rod which connects the crank arm with the carriage be long, the distance of the carriage from its mean position when the crank arm has turned through the angle  $\theta$ , will be  $c \cos \theta$  (see § 113); whilst the distance of the tool, measured parallel to the arm F, from the drill spindle will be  $a \cos \theta$ . The total distance of the tool, measured from the mid-position of the drill spindle, parallel to the arm F, is therefore  $(c + a) \cos \theta$ . The displacement perpendicular to the arm F is  $a \sin \theta$ ; whence, denoting the former by  $x$  and the latter by  $y$ ,

$$\begin{aligned} x &= (c + a) \cos \theta \\ y &= a \sin \theta \\ \therefore \frac{x^2}{(c + a)^2} + \frac{y^2}{a^2} &= 1 \end{aligned}$$

The locus of the tool Q is therefore an ellipse of semi-major and minor axes  $(c + a)$  and  $a$  respectively, the major axis being parallel to the arm F.

When the obliquity of the connecting rod is taken into account, the locus of the tool is not a true, but a distorted ellipse; so that the shape of the hole cut out of the plate is simply an oval which will not be symmetrical about a line perpendicular to the arm F.

The machine just described also serves to illustrate the principle of the ordinary *slotting machine*. When applied for cutting key-ways in shafts, or in drilling cotter holes, the arm carrying the rotating cutters would be replaced by an ordinary plain or twist drill. If the carriage were fixed, a cylindrical hole would be drilled; but when it is given a reciprocating motion by the stud, a long key-way or cotter hole can be drilled. For this purpose the drill would have to rotate very much faster than in the previous case, and the carriage would be given a very slow motion. The mechanism which gives the slow motion to the carriage may, of course, be quite different from that described above.

§ 101. **Machines for shaping Propeller Blades.**—A modified radial drilling machine may also be used to correctly shape out the working side of a screw propeller blade. Suppose, for example,

that the arm F (Fig. 84) is made to oscillate to and fro about its vertical axis through a certain angle by means of gearing connected to the spindle of the cone B. In that case the tool attached to the spindle P will have two motions impressed upon it, namely, a vertical motion due to the screw feed and a motion in a circular arc having an axis coincident with the axis of E, and these two motions will bear some definite relation to each other; consequently the extremity of the tool will trace out a helix, and the pitch of the helix may be varied by having change wheels. Moreover, by placing the carriage L successively in different positions on the arm, the tool will describe different coaxial helices of the same pitch, and if it operate on any fixed body beneath the arm, it will generate a true screw surface (§ 20). This is, approximately, the condition that has to be satisfied for the working side of a screw propeller, and a machine embodying these motions is sometimes used for shaping the blades. A full description of such a machine, with illustrations, will be found in *Engineering* for October 9, 1903.

**§ 102. Copying Tools. Copying Lathes.**—The pantograph is a linkwork motion which faithfully reproduces, on an enlarged or reduced scale, any plane curve or plane section of a body (§ 89). Machine tools may be devised which will faithfully reproduce solid bodies similar in shape to a given body. Two such tools may be noticed.

By means of a copying lathe, specimens of any arbitrary section may be turned from a single pattern, and it therefore bears the same relation to solid bodies that the pantograph does to plane curves. In Fig. 155, A and B are two wheels of equal size turning about fixed centres, and each gearing with an idle wheel, C, so that when A rotates, B rotates at exactly the same speed in the same direction. The iron pattern or template D, which may represent the spoke of a wheel, or any similar body of non-circular section, is attached to the wheel A, and the rough specimen, E (generally of wood), to the wheel B. A sliding carriage, F, carries a wheel, G, and a set of rotating cutters, H, the radius of the cutting edge of the cutters being exactly the same as that of the wheel G. The carriage is pressed against the template D either by springs or a weight, but as D revolves, the

carriage will be pushed to the right. Under these conditions the rapidly rotating cutters H will turn out on E an exact section of D, and by giving the frame a slow motion in a direction parallel

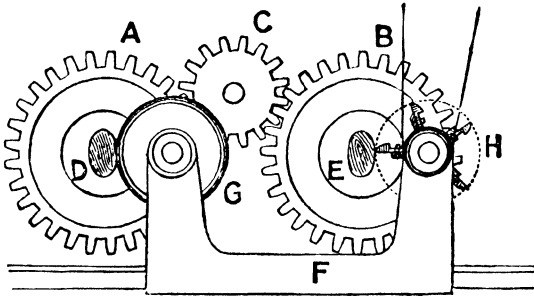

FIG. 155.<sup>1</sup>

to the axes of the wheels, the piece E can be made an exact copy of D.

§ 103. **The Square, Angular, and Round Hole Drilling Machine.**—

A second illustration of a copying tool is a drilling machine, which enables polygonal and other holes to be drilled out. It is used in the manufacture of such things as box spanners, boiler keys, tool handles, and a variety of other articles requiring an angular

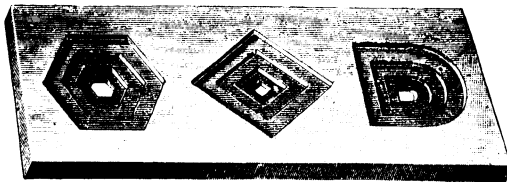

FIG. 156.

hole. Samples of work performed by this machine are illustrated in Fig. 156.

It will be seen that the machine,<sup>2</sup> a general view of which is shown in Fig. 157, resembles in general form an ordinary drilling machine, but it is in the arrangement of the head that the changes

<sup>1</sup> Reproduced from Goodeve's "Elements of Mechanism."

<sup>2</sup> The account of this machine, which is made by the Angular Hole Drilling Company of Nottingham, is taken (by kind permission) from the *Mechanical Engineer*, May 30, 1903.

occur which result in such remarkable work being accomplished. The principle of the machine may be described in the following way. A spindle is supported near the centre in a ball-bearing

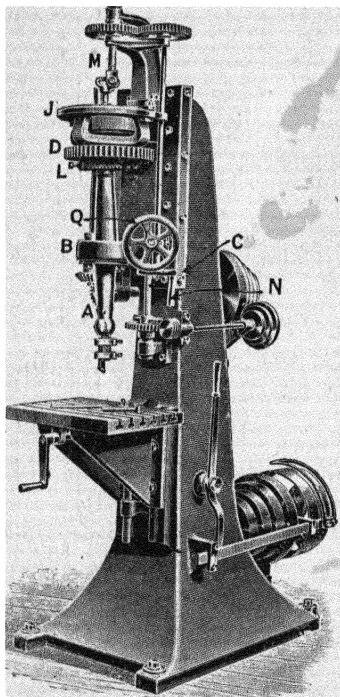

FIG. 157.

socket, so as to give it free play in every direction. At the top of the spindle is provided a roller, which is kept in contact with a template of any desired shape by means of springs. The lower end of the spindle carries the cutting tool, which is of peculiar shape, and so arranged that the cutting edge of the tool is on the centre line of the spindle. The spindle is rotated by means of gearing, and at the same time the roller is made to travel along the inside surface of the template. Whatever shape the template may be, the centre line of the spindle, and with it the cutting edge of the tool, will faithfully reproduce the shape to a reduced scale. The machine, like that just described, is therefore a copying machine.

A reference to Figs. 158 and 159, which represent a side section and a front elevation respectively, will make the component parts of the mechanism clear. A is the spindle turning in the ball-socket bearing B, formed in the sliding-head C, and, passing through the spur wheel D, is provided with the conical roller E, running free upon its upper end. The spindle is embraced in the spur wheel D by a sliding block, G, free to move in a slide formed in the wheel, and pulled off the centre outwards by a pair of strong springs, H, H. These springs cause the roller E to be kept in contact with the template ring F surrounding it. If F be square, it is clear that the centre of the roller will likewise describe a square; if it be

triangular, so likewise will the path described by the centre of the roller; if it be circular, so likewise will the path described by the centre of the roller; and so on. The template F is secured to projections, J, from the head by means of clips, K, so as to admit of easy replacement with other forms, and also to admit of rotation when desired. The set-screw L is provided in the wheel D, to set the sliding block in the centre position when required.

The roller E is of conical form, and is connected to the adjusting screw M above it, so that by adjusting the position of the

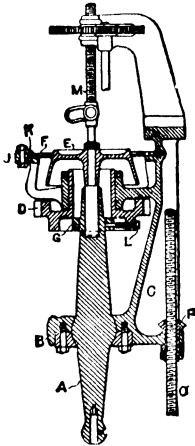

FIG. 158.

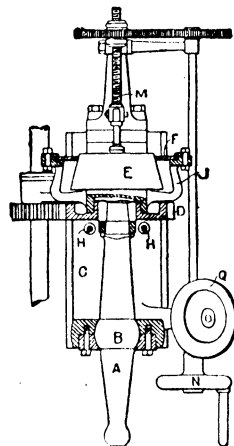

FIG. 159.

roller, a portion of the roller of lesser or greater diameter, as required, may be brought against the template, and consequently the tool is caused to describe a figure corresponding to the template, but varying in size according to the position of the roller. This is useful in adjusting the finishing cut to great nicety, and enables a tapered hole to be drilled. The screw is operated through a pair of spur wheels and the hand-wheel N.

The feed motion is obtained by moving the entire head downwards. The self-acting feed is operated in the ordinary manner, motion being given to the screw O. The nut P is made with a bevel wheel at its upper end, and this is in mesh with a wheel on a shaft having a hand-wheel, Q, secured to it. By this means it is possible to vary the feed during the progress of the self-acting motion.

## CHAPTER IV.

### *MECHANISMS CONSISTING OF FOUR LOWER PAIRS.*

§ 104. THE mechanisms considered in Chapter II. illustrate the uses to which a combination of ordinary gearing may be put. They are, in point of fact, made up of chains consisting of three pairs constantly repeated. The preceding chapter deals mostly with chains which consist of four lower pairs—the chain being used principally on account of some geometrical property rather than to transmit power.

Next, let us consider more fully the simple chains, which consist of four lower pairs, and therefore of four elements. Such a chain may consist of four turning pairs, in which case it is called the *four-bar chain*; of three turning and one sliding pair, in which case it is called the *slider-crank chain*; or of two turning and two sliding pairs, in which case it is called the *double-slider crank chain*. Diagrammatic sketches of these three chains have been already shown in Figs. 9, 1, and 8 respectively. Each chain consists of four elements, so that by fixing each link in turn, four mechanisms may be obtained from each chain. But although these mechanisms may differ greatly from each other in constructive details, and in the purposes to which they are put, it must be remembered that since they are the same kinematic chain, the relative motions of the different parts must always be the same. The different purposes for which they are used will appear as the subject proceeds.

§ 105. **Determination of Velocity Ratio.**—In mechanisms such as are about to be discussed, the different elements usually consist of links which, neglecting the slight changes due to change of temperature and elasticity, are of invariable length. The object

is to determine the velocity ratio of any two points, or of any two turning pairs, in the chain relative to one of the links; and in determining that velocity ratio, one or other of two methods may be adopted, namely—

- (1) The method of the instantaneous centre.
- (2) By drawing the velocity diagram.

For simple linkwork chains, such as those consisting of four links, the first method is, on the whole, the more convenient, and will be discussed first; but for more complicated mechanisms, the second possesses considerable advantages over the first.

§ 106. **Instantaneous Centre of Rotation.**—Let us assume that all the links in the chain move parallel to one plane, in which case the displacement of any link is the same as the displacement of any straight line in that link. The displacement of any link is then equivalent to a rotation about some finite or infinitely distant point. To prove this statement, let (Fig. 160)  $AB$ ,  $A'B'$  represent any two successive

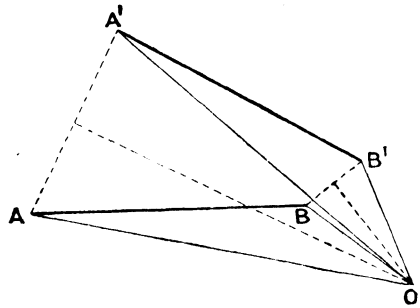

FIG. 160.

positions of a link which moves parallel to the plane of the paper, and bisect  $AA'$ ,  $BB'$  at right angles by lines which intersect at the point  $O$ . Since  $AB$  is equal to  $A'B'$ , the triangles  $OAB$ ,  $OA'B'$  are equal in all respects, so that  $OAB$  may be imagined a rigid triangular frame rotating about the point  $O$ . By a finite rotation about  $O$ , the body can be moved from its first position, represented by  $AB$ , to its second position, represented by  $A'B'$ . For any intermediate position, the points  $A$  and  $B$  will lie on circular arcs having  $O$  as centre, and precisely the same motion could be obtained by having circular slots, having the common centre  $O$ , in which pins at the ends of the link  $AB$  are allowed to slide (Fig. 161). The motion in such a case, whether for large or small displacements, would be precisely the same as if the link  $AB$  were rigidly attached to an arm rotating about the centre  $O$ .

Now, in the general case, the paths traced out by A and B will not be circular arcs, but may be curves of any shape whatever.

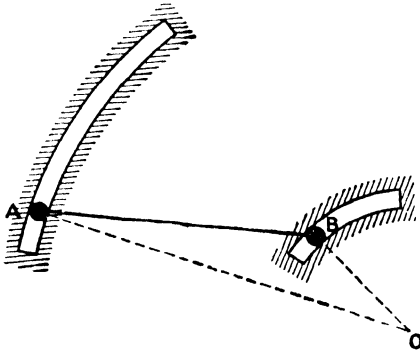

FIG. 161.

In that case, although the body may be brought from its initial to its final position by rotation about one point, yet the intermediate positions which it would then trace out would not coincide with the positions which it is constrained to successively occupy. But if, instead of attempting to bring the body from its initial to its final position

by a finite rotation about one fixed point, it is taken from the first position to a second position, very near to the first, by rotation about some centre (obtained precisely as before), and from its second position to a third, very near to the second, by rotation about some other centre, and so on, until it reaches its final position; then, by successive rotations through small angles about different centres, the body will trace out the exact path required of it. The centres thus obtained are called *virtual* or *instantaneous* centres of rotation.

A second proposition is immediately obvious, namely, *The direction of motion of every point in a body is perpendicular to the line joining that point to the instantaneous centre, and its velocity is proportional to the length of that line.*

Hence, whenever the directions of motion of two points in a rigid link are known, the instantaneous centre is at once determined by drawing perpendiculars to those directions to intersect. That point of intersection is the point about which, for the moment, the body is rotating; and the body may be imagined to extend to that centre, and to actually turn about a pin attached to the frame of the machine. At the instant considered, the instantaneous centre is, therefore, that point in the moving link which is at rest, and its position may be obtained by methods other than that just described (see § 109).

§ 107. **Application to the Four-bar Chain.**—As illustrations of these principles, consider the simple mechanisms referred to in § 104. In the *four-bar chain*, the links  $P_1A$ ,  $P_2B$  are rotating about *permanent* centres,  $P_1$  and  $P_2$  (Fig. 162). The third moving link, namely,  $AB$ , is rotating about some *temporary* or virtual centre, which is obtained as follows: In the position of the mechanism sketched, the point  $A$  is moving perpendicularly to  $P_1A$ , and the point  $B$  perpendicularly to  $P_2B$ . If lines are drawn perpendicularly to these directions of motion—that is, if  $P_1A$ ,  $P_2B$ , be produced—they will intersect in the virtual centre  $O$ ; and for the

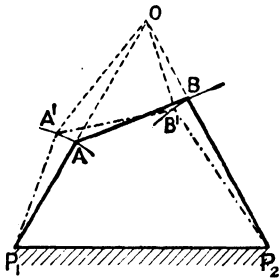

FIG. 162.

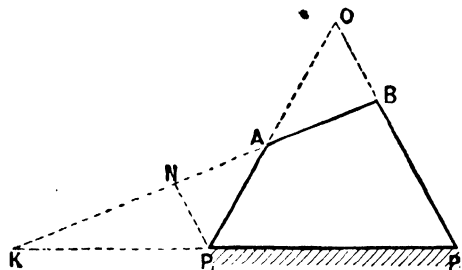

FIG. 163.

instant the link  $AB$  may be considered to rotate as truly about  $O$  as  $P_1A$  rotates about  $P_1$ , or  $P_2B$  about  $P_2$ .

If the mechanism be redrawn after a very slight displacement,  $A$  will come to  $A'$ , and  $B$  to  $B'$ , and the triangle  $OAB$  will swing about  $O$  through the angle  $AOA'$  or  $BOB'$ . Moreover, if  $v_a$ ,  $v_b$  denote the linear velocities of the pins  $A$  and  $B$  respectively—

$$\frac{v_b}{v_a} = \frac{OB}{OA} = \frac{P_1N}{P_1A};$$

where, in Fig. 163,  $P_1N$  is drawn parallel to  $P_2B$  to meet  $BA$ , produced if necessary, in  $N$ . Moreover, if  $\omega_1$ ,  $\omega_2$  represent the angular velocities of the shafts  $P_1$  and  $P_2$ ,

$$\omega_1 = \frac{v_a}{P_1A}, \quad \omega_2 = \frac{v_b}{P_2B}$$

and therefore—

$$\frac{\omega_2}{\omega_1} = \frac{v_b}{v_a} \cdot \frac{P_1A}{P_2B} = \frac{P_1N}{P_1A} \cdot \frac{P_1A}{P_2B} = \frac{P_1N}{P_2B}$$

Expressed in words, if  $P_1A$  be taken, on some scale, to represent the linear velocity of the pin A,  $P_1N$ , on the same scale, will represent the linear velocity of the pin B; and if  $P_2B$  be taken to represent the angular velocity of the shaft  $P_1$ ,  $P_1N$ , on the same scale, will represent the angular velocity of the shaft  $P_2$ . Moreover, if the coupler produced meet the line of centres in K, the ratio  $\frac{\omega_2}{\omega_1}$  is at once seen to be equal to  $\frac{KP_1}{KP_2}$ ; or, expressed in words,

*the angular-velocity ratio of the two shafts is inversely as the segments into which the coupler divides the line of centres.* This is an important result which will be used when dealing with toothed wheels.

If the link  $P_1A$  be equal in length to  $P_2B$ , and the coupler AB be equal to the distance between the centres,  $P_1$  and  $P_2$ , both the linear-velocity ratio of the points A and B, and the angular-velocity ratio of the shafts  $P_1$  and  $P_2$  are equal to unity. The mechanism is then the coupling-rod mechanism of a locomotive (Fig. 164). But if these proportions are not satisfied, both the linear-velocity ratio and

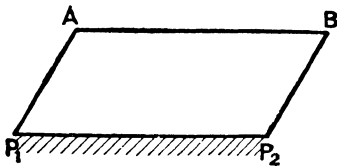

FIG. 164.

the angular-velocity ratio vary according to the configuration of the mechanism.<sup>1</sup>

The constructions for finding the linear-velocity ratio of A and B, or the angular-velocity ratio of the shafts  $P_1$  and  $P_2$ , are true whatever the relative lengths of the different links. In particular, one of the levers, say  $P_2B$ , may be of infinite length, in which case B would describe a straight line, and the chain would become the slider-crank chain, as shown in Fig. 165. If  $P_1N$  be drawn parallel to  $P_2B$ , that is to say, perpendicularly to the line of stroke of B, to meet the rod BA produced in N, the

<sup>1</sup> For a fuller discussion, see § 130.

distance  $P_1N$  will still represent the velocity of B on the same scale that  $P_1A$  represents the velocity of A.

Or, again, the coupler AB in Fig. 163 may be replaced by a block which rotates about the pin A, and slides in a slot rigidly attached to the lever  $P_2B$ , as shown in Fig. 166. Provided B is the centre of the circular slot, the motion transmitted is exactly the same as that transmitted by the mechanism of Fig. 163.

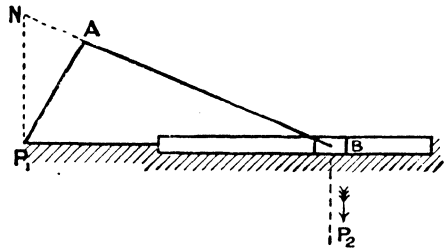

FIG. 165.

The radius of the slot may be anything, and in particular, may be infinite; but in all cases, the point K is the point where the line joining the pin A with the centre of curvature of the slot cuts the line of centres. In Fig. 167, the slot is straight, and its centre line passes through  $P_2$ , so that the line joining A with the centre of

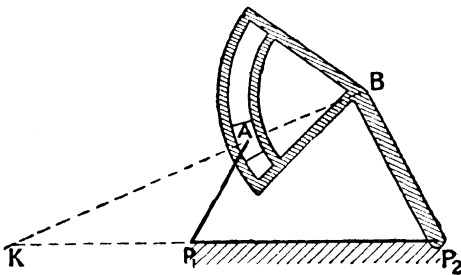

FIG. 166.

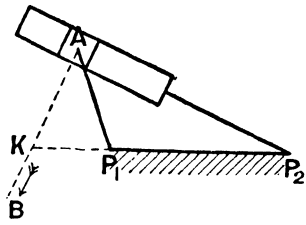

FIG. 167.

curvature of the slot is the line through A perpendicular to the centre line of the slot; and the angular-velocity ratio of the shafts  $P_2$  and  $P_1$  is  $\frac{KP_1}{KP_2}$ .

§ 108. Direct-acting Engine. Pin and Slot. Eccentric.—As a second application, take the slider-crank chain, and consider, first, the mechanism of the direct-acting engine. In this mechanism the link PA (Fig. 168) rotates continuously about the fixed centre

P, whilst the block B moves to and fro in a straight line. The instantaneous centre O of the third moving link AB is where PA produced meets the line through B drawn perpendicular to the stroke. If  $v_a$ ,  $v_b$  represent the linear velocities of the crank pin and piston respectively—

$$\frac{v_b}{v_a} = \frac{OB}{OA} = \frac{PN}{PA}$$

where PN is drawn through P perpendicular to the stroke to meet the connecting-rod, produced if necessary, in N. Thus, if the crank radius PA represent the linear velocity of the crank pin,

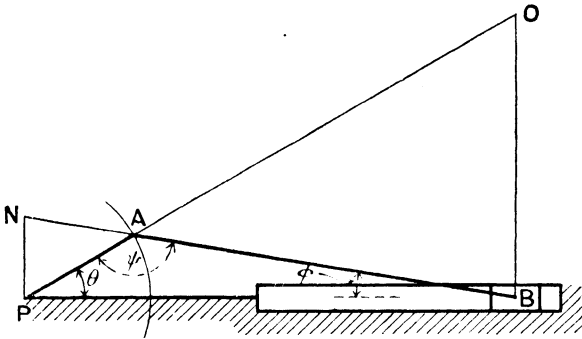

Fig. 168.

the length PN will represent, on the same scale, the velocity of the piston.<sup>1</sup> This is the same result as that obtained in § 107, in which it was obtained as a particular case of the general problem.

Again, in this mechanism there are three turning pairs, namely at P, A, and B, and each of these turning pairs has a certain angular velocity. Let the angles at P, A, and B be denoted by  $\theta$ ,  $\psi$ , and  $\phi$ . The angular velocity of the crank-shaft pair (P) is the rate at which  $\theta$  is increasing; that of the crank-pin pair (A), the rate at which the crank arm and connecting rod are separating, that is, the rate of increase of  $\psi$ ; whilst that of the crosshead-pin pair (B) is the rate at which the connecting rod is swinging about B, and is, therefore, the rate of increase of  $\phi$ . To find the corresponding

<sup>1</sup> For a fuller discussion, see § 113.

increments in these angles, draw the mechanism in a second position very near to the first (Fig. 169). Since each side of the triangle OAB turns through the same angle, namely,  $\delta\phi$ , the arc AA' is equal to PA  $\cdot$   $\delta\theta$  and also to AO  $\cdot$   $\delta\phi$ , and therefore—

$$\frac{\delta\phi}{\delta\theta} = \frac{PA}{OA} = \frac{AN}{AB} \quad (\text{Fig. 168})$$

Moreover, in all configurations of the mechanism,  $\theta + \phi + \psi = 180^\circ$ ; so that—

$$\delta\psi = -(\delta\theta + \delta\phi)$$

whence, quantitatively—

$$\delta\theta : \delta\phi : \delta\psi = AB : AN : NB \quad (\text{Fig. 168})$$

the negative sign in the expression for  $\delta\psi$  meaning that if  $\theta$  and  $\phi$

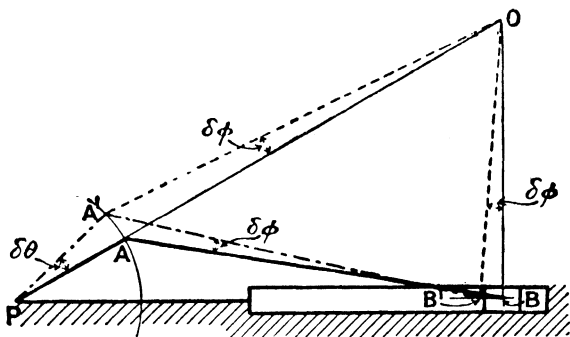

FIG. 169.

are increasing,  $\psi$  is decreasing. And since the angular velocity ratios of the three turning pairs at P, B, and A are proportional to  $\delta\theta$ ,  $\delta\phi$ ,  $\delta\psi$  respectively, the above relationship may be expressed in words as follows; namely, that if the length of the connecting rod AB be taken to represent the angular velocity of the crank shaft, the lengths AN and BN will, on the same scale, respectively represent the angular velocities of the gudgeon pin and crank pin. The rubbing velocities of the three pins in their respective bearings are equal to the angular velocity of the three turning pairs multiplied by the radius of the corresponding pin.

In obtaining the angular-velocity ratios, we have assumed the link common to the crank shaft and block to be fixed. Since the relative motions depend simply upon the chain, precisely the same results may be applied which ever link in the chain is fixed. The importance of fully realizing what this statement means is so great that it will be well to consider separately the mechanism obtained when, say, the crank arm is the fixed link (Fig. 170). In that case the permanent centres of rotation are A and P, and as AB and PC rotate about their respective centres, the block B slides in the slot PC. The arrangement is then known as the *pin-and-slot* mechanism. Using the result quoted

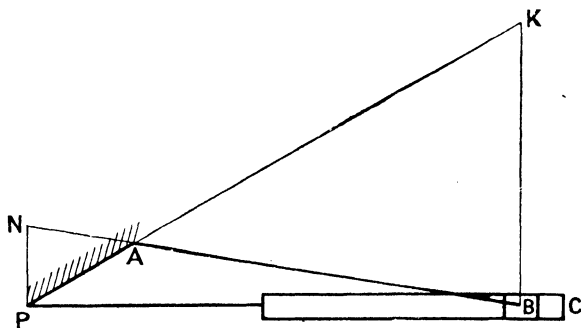

FIG. 170.

in § 107 (compare with Fig. 167), the angular-velocity ratio of the shaft P is to that of A as KA is to KP—K being the point where a line through B perpendicular to the slot meets the line of centres. From similar triangles, this ratio is at once seen to be equal to  $\frac{AB}{NB}$ , which is precisely the same result as that just obtained. But it might also be obtained without using any previous result by finding the instantaneous centre of the block B relative to the link AP. To do so, the directions of motion of two points in the block B must be known. The direction of motion of the pin B is perpendicular to the arm AB, and therefore the instantaneous centre of the block must lie in AB or AB produced; but any second point in the block has two motions impressed upon it, namely, the sliding motion in the slot, and the rotatory motion

of the slot about P, and as the magnitudes of these motions are not known, the direction of motion of any arbitrary point is not known. If, however, the block be assumed to extend as far as the centre P, and the point in the block immediately over P is considered, the rotary motion of that point about P is clearly zero, and the sliding motion in the slot is the resultant motion of the point. Hence, if PN be drawn perpendicularly to the direction of the slot, the instantaneous centre of the block must lie in this line, and must therefore be the point of intersection N with BA produced, so that the block, at the instant, may be imagined to rotate as truly about N as the link AB rotates about A. Plot the mechanism in any position near to the first as shown by the broken lines in Fig. 171, and let  $\theta$ ,  $\phi$ ,  $\psi$  have precisely the same

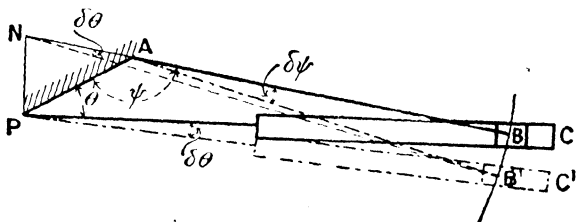

FIG. 171.

meanings as in Fig. 168. The angular motion of the block about N must be the same as that of PC about P, and, for a slight displacement, must be  $\delta\theta$ , and the corresponding angular displacement of AB about A is  $\delta\psi$ ; from which it follows that the arc BB' is equal to either  $AB \cdot \delta\psi$  or  $NB \cdot \delta\theta$ , so that—

$$\delta\theta : \delta\psi = AB : NB$$

as before.

These arguments are not necessary, but they emphasize the fact that, having obtained the velocity ratios of the three turning pairs for one mechanism of the chain, they will be the same for all mechanisms which can be derived from that chain.

The proportions of the different links and pins in the mechanism just considered are quite arbitrary. In particular, the crank pin may be so large as to embrace the crank shaft, in which case

the crank pin may be keyed directly to the crank shaft (Fig. 172), and a strap, attached to the end of the rod, may encircle the pin.

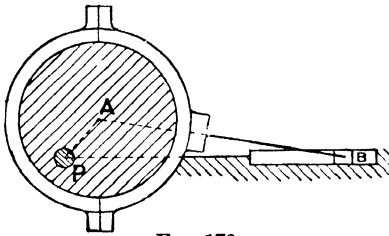

FIG. 172.

Kinematically, the motion will be exactly the same as before, but the arrangement has the advantage that no gap in the crank shaft is necessary for the connecting rod to pass through. The arrangement as sketched in Fig. 172 is usually called an *eccentric*.

§ 109. **Cylinder rolling on the Ground.**—As a further illustration, take the case of a rack and pinion, or, what is kinematically equivalent, of a wheel rolling without slipping over the ground. The instantaneous centre of the wheel relative to the ground may be found, provided the directions of motion of any two points in the wheel are known. The path traced out by the centre A (Fig. 173)

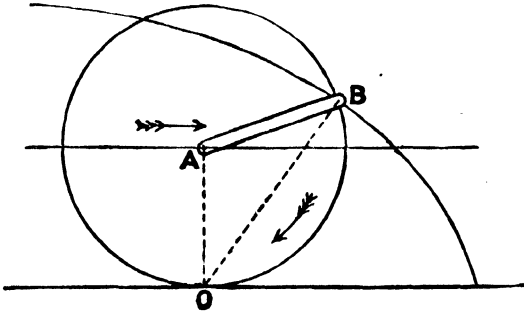

FIG. 173.

of the wheel is a horizontal straight line, whilst that of any point, B, in the circumference is a cycloid. The instantaneous centre is where the vertical through A intersects the normal to the cycloid at B, and is therefore known, from the geometry of the cycloid, to be the point of contact, O. But in this particular case, the instantaneous centre may be more readily obtained by finding the position of the point in the cylinder which, at the instant, is at rest (§ 106). Thus, any point, such as B, has two motions impressed

upon it, namely, a motion of rotation about A, and a motion of translation common to every point of the wheel; and the speed of translation, since there is no slipping, is the same as the circumferential speed. The bottom point O of the wheel moves backwards due to the rotation, and forwards due to translation, and since the speeds of rotation and translation are equal in magnitude but of opposite direction, the resultant velocity of the bottom point in the wheel is zero. The velocity of any point in the wheel is proportional to its distance from O, and, in particular, the velocity of the top point of the wheel is double that of the centre of the wheel. This explains why a plank rolling on a roller, which in turn rolls on the ground, travels twice as fast as the roller. By the time the plank (Fig. 174) has run over the roller, the roller has travelled a distance equal to the length of the plank, and the plank itself has travelled a distance equal to twice its own length.

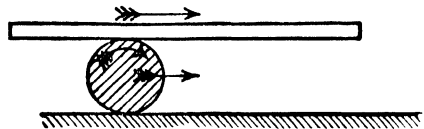

FIG. 174.

This principle is made use of in some printing machines to obtain automatic delivery of the printed sheets on to the taking-off board. The printed sheets are not discharged from the printing

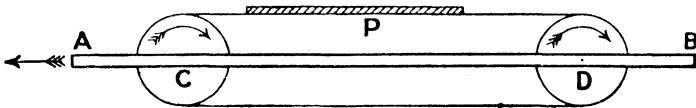

FIG. 175.

cylinder directly on to the reciprocating table, but on to endless bands, the arrangement being shown in Figs. 175, 176, which represent a front and end elevation respectively. The reciprocating table AB carries two equal pulleys, centres C and D, which are connected by an endless band. To the same spindles as C and D are attached pinions, E, equal in diameter to C and D, which gear with a fixed rack, F, at the side of the machine. The result is, that as AB reciprocates, carrying with it the pulleys C and D, every

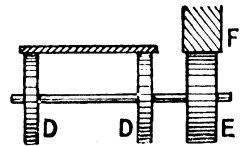

FIG. 176.

point such as P in the upper side of the band is at rest, and therefore, if the sheet be discharged from the machine on to the upper band, the sheet is not carried to and fro with the table, but remains stationary, and simply drops down on to the taking-off board when the table has moved sufficiently far to the left.

§ 110. **Effect of Slipping.**—Again, returning to the case of the wheel rolling on the ground, if slipping takes place, the distance through which the wheel moves for each revolution is less than the circumference of the wheel, and the instantaneous centre of rotation is no longer at the point of the contact of the wheel and ground. The path traced out by any point in the circumference of the wheel is not now a cycloid, but a looped trochoid. The

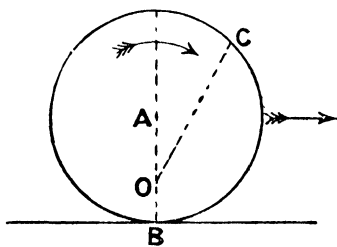

FIG. 177.

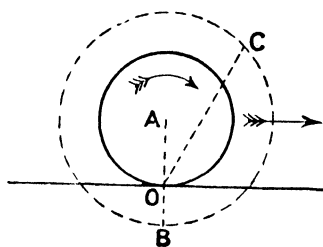

FIG. 178.

position of the instantaneous centre is best found by finding the point of rest in the wheel. Let  $\omega$  be the angular velocity of the wheel about its axis,  $r$  its radius, and  $v$  the speed of translation. The velocity of a point,  $O$  (Fig. 177), in the vertical diameter is  $(\omega \cdot AO - v)$  backwards, and is zero provided  $AO = v/\omega$ . The instantaneous centre of rotation is therefore at a distance  $v/\omega$  below the centre, and every point in the wheel is rotating about  $O$  with the same angular velocity with which the wheel rotates about  $A$ . This is evident when it is remembered that the velocity of the centre of the wheel is  $OA \times$  angular velocity about  $O$ , and is also equal to  $OA \times$  angular velocity about  $A$ ; whence the two angular velocities are the same. The motion, in point of fact, is exactly the same as if a cylinder (Fig. 178) of radius  $OA$  rolled without slipping on the ground. Any point  $C$  is moving perpendicularly to  $OC$  with the velocity  $\omega \cdot OC$ .

§ 111. **Feathering Paddle-wheels.**—An interesting illustration of rolling with slipping is paddle-wheels. In a vessel propelled by paddles, the distance the vessel advances for each revolution of the paddle-wheel is less than the circumference of the paddle-wheel circle, on account of the floats acting on a yielding fluid. The instantaneous centre of the paddle-wheel may be found provided we know the speed of the vessel, the effective radius of the circle described by the floats, and the angular velocity of the paddle shaft. If these quantities be represented by  $v$ ,  $r$ , and  $\omega$

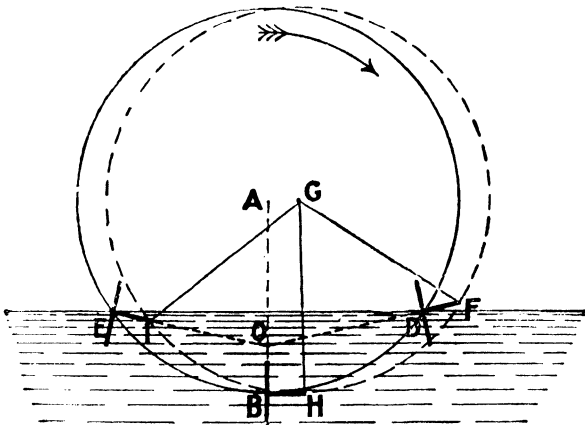

FIG. 179.

respectively, the distance of the instantaneous centre  $O$  below the paddle shaft is  $v/\omega$ . The “slip” of the paddle is defined to be

$$\frac{\text{circumferential speed of paddle} - \text{speed of ship}}{\text{circumferential speed of paddle}}$$

and is therefore equal to

$$\frac{\omega r - v}{\omega r} = 1 - \frac{v}{\omega r} = 1 - \frac{AO}{AB} = \frac{OB}{AB} \quad (\text{Fig. 177});$$

so that if the “slip” is given, the instantaneous centre may be at once found, and conversely.

Now, in Fig. 179, let  $DE$  represent the water-level, so that the

points D and E are the points where the floats first enter and leave the water. If O is the instantaneous centre of the wheel, obtained by the above formula, the point D is moving perpendicularly to OD, and therefore, if the float simply dives into the water without causing agitation, or, in other words, if the floats feather, the face of the float when entering the water must be perpendicular to OD. Similarly, if the floats emerge from the water without causing agitation, they must, in the position E, be perpendicular to OE; and also, to get the most direct effect when in the water, they must be vertical when at the bottom point B. If the floats be rigidly attached to the frame of the paddle-wheel, these three conditions would not be satisfied, and in order to make the floats feather some mechanism has to be used. The most common mechanism effecting the required purpose is that of the four-bar chain. The floats turn on pins at their centres which are carried by the paddle-wheel, and they are provided with stem levers, such as DF, rigidly attached to the floats. The extremities of these stem levers are connected by rods of equal length to a fixed centre, G, so that there are a number of four-bar chains such as AGFD. As the paddle-wheel rotates, the angular motion of GF causes a corresponding angular motion of the stem lever FD, and, therefore, of the floats. If the slip at which the paddle works is known, the positions of the floats for the three positions D, B, and E are determined in the manner just described, and, knowing the lengths of the stem levers, the positions of the extremities F, H, I of the stem-levers are determined. By obtaining, graphically, the centre of the circle passing through F, H, and I, the length of the rods and the position of the centre G may be found. The positions which the floats occupy when out of water are a matter of indifference.

§ 112. **Rolling Cylinders.**—As a further illustration of the use of the instantaneous centre, consider the case of a cylinder rolling without slipping on the outside of a second cylinder. We may imagine the rolling cylinder to rotate on axis  $P_2$  (Fig. 180) at the extremity of the arm  $P_1P_2$ , the arm itself rotating about the centre  $P_1$ . When the rolling circle has made one turn relative to the arm, it will have rolled over an arc equal to its own circumference on the

fixed circle, and will have moved from the full-lined to the dotted-lined position. Hence if  $r_1, r_2$  be the radii of the fixed and rolling circles respectively, the angle turned through by the arm will be  $2\pi \times \frac{r_2}{r_1}$ ; or expressed differently, if  $\omega_1$  be the angular velocity of the arm about  $P_1$ , and  $\omega_2$  be the angular velocity of the rolling cylinder about  $P_2$  relative to the arm—

$$\omega_2 : \omega_1 :: r_1 : r_2$$

Now consider the point of contact  $K$  in the rolling cylinder. Due to rotation about  $P_2$ , it has a velocity, relative to the arm, of  $\omega_2 r_2$  from right to left; and due to rotation of the arm, the point in the arm opposite  $K$  has a velocity from left to right of  $\omega_1 r_1$ . Hence the resultant velocity of the point  $K$  is—

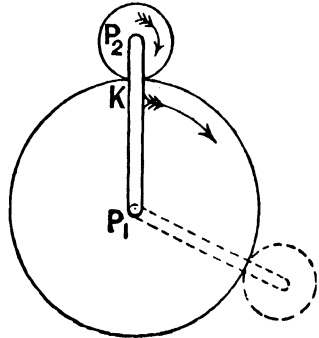

FIG. 180.

$$\omega_2 r_2 - \omega_1 r_1$$

from right to left, and this is zero on account of the relationship just proved. Thus the instantaneous centre of the rolling cylinder is the point of contact  $K$ , and every point in the rolling circle is rotating about  $K$  with a certain angular velocity. To find that angular velocity, the point  $P_2$  is a point both in the arm and the rolling cylinder. Considered as a point in the arm, it has a velocity  $\omega_1 \cdot P_1 P_2$ ; considered as a point in the cylinder, it has a velocity  $\omega \cdot K P_2$ , where  $\omega$  is the angular velocity of rotation about  $K$ . Equating, we obtain that—

$$\begin{aligned} \omega &= \omega_1 \cdot \frac{P_1 P_2}{K P_2} = \omega_1 \left( \frac{r_1 + r_2}{r_2} \right) = \omega_1 \frac{r_1}{r_2} + \omega_1 \\ &= \omega_2 + \omega_1 \end{aligned}$$

Thus every point in the rolling circle is rotating about  $K$  with an angular velocity  $\omega_1 + \omega_2$  (compare § 66).

FULL DISCUSSION OF THE MECHANISMS CONSISTING OF FOUR  
LOWER PAIRS.

(1) *Mechanism of Direct-acting Engine.*

§ 113. **Direct-acting Engine. Curves of Velocity. Dead Points.**— Consider, first, the mechanism of the direct-acting engine. It has been shown (§ 108) that for any position of the crank arm, such as PA (Fig. 181), the velocity ratio of the piston and crank pin is  $\frac{PN}{PA}$ . This ratio is not constant throughout the stroke, but varies from point to point, and the character of the variation

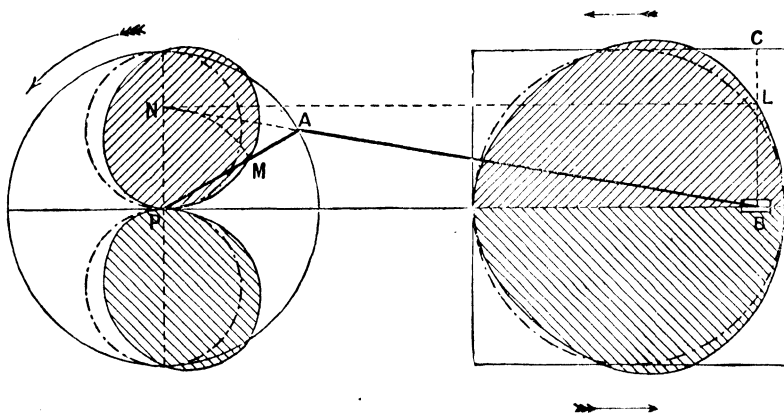

Fig. 181.

can best be seen by drawing a curve. Suppose, for example, that the crank shaft rotates with uniform angular velocity, and that, in all positions, the crank radius represents, on some scale, the constant crank pin velocity; so that the velocity of the piston will be represented by PN. In Fig. 181, let PAB represent one configuration of the mechanism, and mark off the length PM, along the crank radius, equal to PN. Plot the mechanism in a number of positions, and repeat the construction for each position; and join the points M so obtained by a smooth curve. The result will be the two oval curves shown, which are an exact reflection of each

other, the upper curve referring to the motion of the piston from right to left, and the lower one from left to right. The curves will be inclined over towards the cylinder, and each curve will cut the crank-pin circle in two points, these points corresponding to the position of the crank arm for which the crank pin and piston have the same velocity. In one of these positions the crank arm is clearly perpendicular to the stroke, whilst the other position can be readily found by a graphical construction which is given as an example at the end of the book. For some position of the crank arm the piston has its maximum velocity, and this happens when the position of the crank is such that the crank arm and connecting rod are very nearly, but not quite, perpendicular to each other.<sup>1</sup> For any arbitrary position of the crank arm, the velocity ratio of the piston to the crank pin is simply the ratio of the polar distances, such as  $\frac{PM}{PA}$ , of the oval curve and the crank-pin circle. The oval curves obtained in the manner described are therefore called the *polar curves of velocity*.

The results may be represented in another way, namely, on a *piston base*. For each position of the piston, such as B, erect an ordinate to represent the velocity of the piston in that position. On the same scale as before, the ordinate will be equal to PN, so that by drawing NL parallel to the stroke, the ordinate BL is at once obtained. Let this be done for a sufficient number of positions of B, and the points L joined by a curve, the shape of which will be as shown—the upper curve referring to the motion from right to left, and the lower one from left to right, the two curves being exact reflections of each other. The distance of the horizontal lines from the line of stroke is equal to the crank radius, so that the ratio of the ordinates  $\frac{BL}{BC}$  represents the velocity ratio of the piston and crank pin in any position; and the crest of each of these curves is nearer to the back end than to the front end of the cylinder.<sup>2</sup> The *average* velocity ratio of

<sup>1</sup> See § 163 for a discussion of this problem.

<sup>2</sup> The back end of the cylinder is the end furthest from the crank shaft; the front end is the end nearest to the crank shaft.

the piston to the crank pin is obtained from the consideration that whilst the piston performs its double stroke, the crank pin traces out the crank-pin circle; consequently the average velocity ratio is  $\frac{2}{\pi}$ , i.e. is 0.637.

If the connecting rod be of very great length compared to the crank radius, the obliquity of the rod, that is to say, its inclination to the line of stroke, is so small that it may be neglected in all positions of the mechanism, and the rod taken as parallel to the stroke. In that case, if  $\theta$  be the angle turned through by the crank arm measured from the line of stroke,  $PM = PN = PA \sin \theta$ , and therefore the oval curves become circles described on the vertical radii of the crank-pin circle as diameters. Moreover, the position of the piston is the same as that of the foot of the perpendicular from A on to the line of stroke, and the height of A above the line of stroke now represents the velocity of the piston; so that the curve on a piston base simply becomes a semi-circle. The chain-dotted curves represent the curves of velocity when obliquity is neglected.

Again, in this mechanism, the piston is the driver, and the crank shaft is the follower, and the piston is made to reciprocate by the steam, air, or water pressure acting alternately on the two sides of the piston, so that a motion of reciprocation of the piston is converted into a continuous rotation of the crank shaft. When the piston is at either end of the stroke, the crank arm and connecting rod are exactly in one line, and consequently, whatever the magnitude of the force on the piston, the force transmitted through the connecting rod has no component in the direction tangential to the crank-pin circle. There is nothing, therefore, tending to cause the crank shaft to rotate, or, if it does rotate, it might equally well rotate in a counter-clockwise as in a clockwise direction. In these particular positions of the mechanism, namely, when the crank pin is on the line of stroke, the chain is not closed, and to guarantee the motion of the crank pin being continuous over the *dead points*, as they are termed, precautionary measures must be taken. One method is to use two or more similar mechanisms having a common crank shaft with the crank

arms placed at different angles, as in the two-, three-, or four-cranked engine. In that case, when one of the crank pins is on the dead centres, one of the others is most favourably situated for receiving the motion of its piston, and so the motion of rotation of the crank shaft is definite and continuous. Another method is to use a massive fly-wheel, which, by alternately storing and restoring kinetic energy, enables the crank arm to rotate past the dead centres without difficulty. The mass of the crank shaft and arm might of themselves be sufficient for the purpose.

§ 114. **Quick-return Motion. Curves of Velocity. Advantages as applied to Single-acting Engines.**—If the crank shaft were the driver, and the piston the follower, the chain would be closed in all positions without any extraneous aid. In such a case a motion of continuous rotation would produce a motion of reciprocation, and if the shaft rotated uniformly, the times occupied by the reciprocating piece would be the same for each stroke. But this mechanism may be readily converted into a quick-return motion, and therefore made suitable for actuating the tables of small planing machines or the rams of shaping machines, by placing the centre line of the shaft some distance below the line of stroke. In Fig. 182, the centre of the rotating shaft is P, and the line of stroke of B is  $B_1B_2$ . When the crank pin is at A, the reciprocating piece or ram is at B. The length of the stroke of B is not then twice the crank radius, but may be obtained by describing arcs of centre P, and radii equal to  $(AB \pm AP)$  to meet the line of stroke in  $B_1$  and  $B_2$  respectively. Then  $B_1, B_2$  will represent the extreme positions of the reciprocating piece—the corresponding positions of the crank pin being  $A_1$  and  $A_2$ —and the stroke is the distance  $B_1B_2$ , which is greater than twice the crank radius. Whilst the reciprocating piece moves from  $B_1$  to  $B_2$ , the crank pin describes the arc  $A_1CA_2$ , and in the return stroke, when the reciprocating piece moves from  $B_2$  to  $B_1$ , the crank pin describes the arc  $A_2C'A_1$ . Thus assuming that the shaft rotates uniformly, the ratio of the times occupied in performing the two strokes is equal to the ratio of the angles which the arcs  $A_1CA_2$  and  $A_2C'A_1$  subtend at P, and consequently this mechanism may be used as a quick-return motion, the cutting

stroke—taking a counter-clockwise rotation of the shaft—being from left to right, and the return stroke from right to left. The average cutting velocity is the velocity of the crank pin multiplied by the stroke  $B_1B_2$  and divided by the length of the arc  $A_1CA_2$ ; and the average return velocity is the crank-pin velocity multiplied by the stroke  $B_2B_1$ , and divided by the length of the arc  $A_2C'A_1$ . To find the actual velocity of the ram or table in any position  $B$ , in, say, the cutting stroke, the instantaneous centre of the rod  $AB$

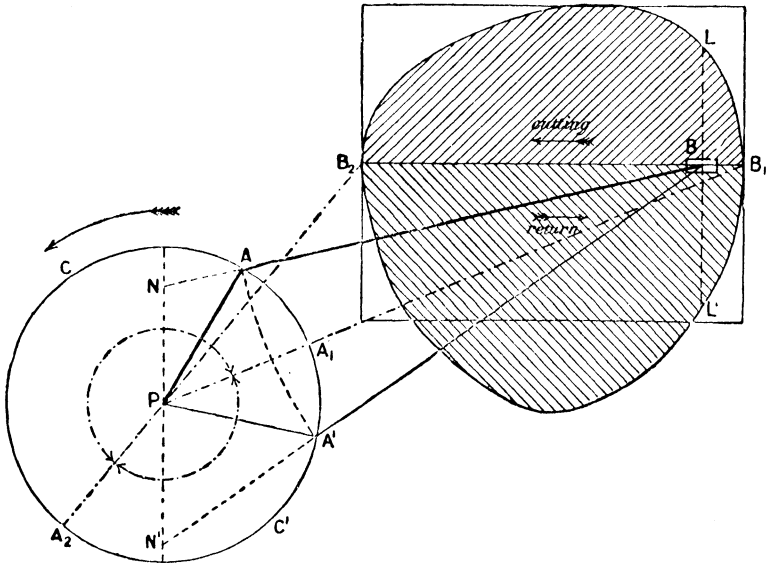

FIG. 182.

is the point of intersection of  $PA$ , produced, with the perpendicular through  $B$  to the line of stroke, and consequently, as in the ordinary direct-acting mechanism, if a line through  $P$  be drawn perpendicularly to the stroke to meet  $BA$  produced, if necessary, in  $N$ , then  $PN$  will represent the velocity of the ram on the same scale that  $PA$  represents the velocity of the crank pin. A curve of velocity might therefore be drawn on a ram base (making  $BL$  equal to  $PN$ ), and so the upper curve obtained which gives the velocity of the ram for any position in the cutting stroke. For

the position B of the ram in the return stroke, the position of the crank pin is at A', so that the velocity of the ram is PN', and the curve of velocity for the return stroke (making BL' equal to PN') will be represented by the lower curve. The distance of the two parallel lines from the line of stroke is equal to the crank radius, and therefore represents the crank-pin velocity. When the crank occupies the vertical position, the ram and crank have the same velocity.

When this mechanism is used for actuating the tables of small planing machines, or the rams of shaping or slotting machines, the angular velocity of the shaft P is governed by the maximum cutting velocity of the tool which can be allowed, and which depends on the material operated upon and the depth of the cut, but which is known from practical experience in any particular case. Approximately, the maximum cutting velocity of the tool may be taken to be the velocity of the pin A, so that, knowing the crank radius, the speed of rotation of P is at once found. Moreover, when applied for such purposes, the crank arm PA is replaced by a circular spur-wheel or plate, which is attached to a spindle rotating in bearings, and which is provided with a diametral slot in which a block carrying the pin A can slide, so that by clamping the block in various positions, the stroke of the table can be readily varied to suit the work required. The spur-wheel is driven by gearing and belting from the counter-shafting of the machine. The effect of reducing the radius PA is clearly to reduce the stroke, and to make the times of cutting and return more nearly equal to one another. With the same speed of rotation, the time occupied in the double stroke is the same whatever the length of the stroke, so that the average velocity is less the shorter the stroke. If, therefore, the maximum cutting velocity has to be the same for all lengths of strokes, the speed of the driving wheel must be increased—by means of speed cones—as the stroke is decreased.

Referring to the ordinary quick-return motions obtained by belting and gearing (§§ 45, 46), it will be remembered that the speed of the table is uniform throughout the stroke (except at the beginning of the stroke when the mass is being accelerated

or retarded), and is the same for all lengths of strokes, provided the driving pulleys rotate at the same speed; and, moreover, the time ratio is the same for all strokes.

An advantage of the arrangement illustrated in Fig. 182 is that throughout the greater part of the cutting stroke, the connecting rod is inclined to the line of stroke at a less angle than in the case where the crank shaft is in the line of stroke; and consequently a more direct pull or thrust is imparted to the tool.

Again, the same arrangement is sometimes used in high-speed *single-acting* steam-engines,<sup>1</sup> or in gas-engines, in which case the block B is the driver. The advantage of the arrangement as thus applied is twofold. In the ordinary arrangement in which the axis of the shaft intersects the axis of the cylinder, as in Fig. 181, if the working end of the cylinder is the back end, the connecting rod is in compression throughout both strokes, since in the working stroke (from right to left), the steam or gas pressure is transmitted to the crank pin, and in the exhaust stroke the force necessary to expel the steam or gas from the cylinder is transmitted from the pin to the piston. The crosshead consequently presses alternately on the two guides in the two strokes, since the obliquity of the rod changes in the two strokes; and, in addition, the crank shaft is only subjected to a driving force for half a revolution. But in the arrangement of Fig. 182, the rod lies on the same side of the line of stroke in both strokes, and consequently the crosshead is kept constantly pressed against the same guide, with the result that "knocking" from guide bar to guide bar is prevented when the piston changes its direction of motion. Moreover, with this arrangement, the crank shaft is subjected to a driving force for more than half a revolution—the working stroke being from right to left—and the variations in the driving force are somewhat smaller than they would otherwise be, with the result that the shaft will run steadier.

§ 115. **Approximate Solution of the Quick-return Mechanism.**—In the quick-return motion discussed in the previous article, the dead points are  $A_1, A_2$  (Fig. 182). The longer the connecting rod

<sup>1</sup> For example, in the *Peache* high-speed engine.

relative to the crank-arm, the more nearly equal to unity is the time ratio, and the more nearly the dead points lie at opposite ends of the same diameter. Thus, in Fig. 183,  $A_1$ ,  $A_2$  are obtained as already described, and these are the more nearly at opposite ends of a diameter, the longer the connecting rod compared to the crank radius. When, therefore, the rod is very long compared to the crank radius, the approximate position for the dead centres may be obtained by bisecting the stroke  $B_1B_2$  in  $D$ , and joining  $PD$  to meet the crank-pin circle in  $E$  and  $F$  (Fig. 183). A rotation of the crank shaft through the angle  $APE$  in one direction, and through the angle  $APF$  in the other direction, will bring the crank pin very approxi-

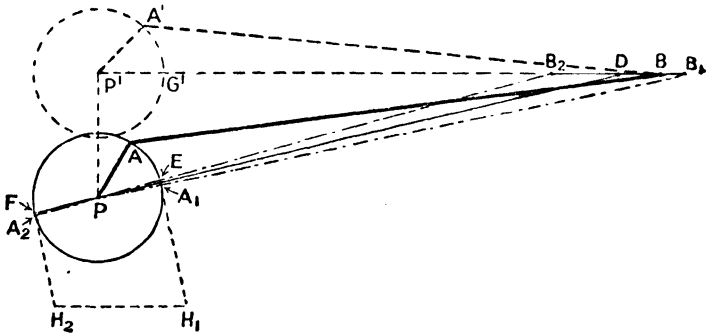

FIG. 183.

mately on its dead centres, and the piston very approximately to the ends of the stroke. Under these conditions, the motion of the piston  $B$  may be imagined obtained by some crank rotating about a centre on the line of stroke produced. Clearly, the equivalent crank must rotate at the same speed as the crank  $PA$ , its length must be equal to half the stroke  $B_1B_2$ , and its "phase" must be such that a rotation through an angle equal to  $APE$  or  $APF$  will bring it on the dead centres. Hence, draw through  $P'$ , a line,  $P'A'$ , equal in length to half the stroke  $B_1B_2$ , and in such a direction that the angle  $G'P'A'$  is equal to the angle  $APE$ . If  $B$  be assumed connected with  $A'$  by a long rod, the motion of  $B$  so obtained will be very nearly the same as that actually obtained from  $PA$ —that is to say, the strokes will be the same, the times occupied will be

the same, and the piston will be at the ends of its stroke at the proper instant.<sup>1</sup>

It must be understood that the equivalent crank only approximately reproduces the displacement and motion of B, and that it can hardly be applied to cases such as that discussed in § 114. Its chief application is in obtaining an approximate solution of the displacement of a valve which is driven, from the crank shaft of an engine, through a combination of links (see § 154). In such cases, the rod is usually twenty to twenty-five times the length of the crank, and the motion of the reciprocating piece is sensibly simple harmonic.

A second, and perhaps more convenient, approximation is to find the approximate position of the dead centres by striking a circle of centre P and radius equal to the length of the rod to meet the stroke in D (instead of bisecting the stroke), and joining PD to meet the crank circle in E and F; and to find the stroke of the reciprocating piece by drawing lines through E and F, perpendicular to EF, to meet a line parallel to the stroke in  $H_1H_2$ . The length of the equivalent crank will be half the length of  $H_1H_2$ , that is, will be equal to  $PA \sec PDP'$ . This follows from the fact that if the piece B actually reciprocated in the direction PD, the true travel in that direction would be  $2 \cdot PA$ , that is, equal to EF; and hence the travel along any oblique direction, such as the horizontal direction, is equal to  $EF \sec PDP'$ . The phase is obtained as before.<sup>2</sup>

In all cases where approximate methods are applicable, the difference in results obtained by these two methods is inappreciable, and both agree very closely with the actual motion of B.

**§ 116. Mechanism for actuating the Rudder-head in Ships.**—The mechanism of the direct-acting engine, in conjunction with a right- and left-handed screw, is very commonly adopted for transmitting the motion from the steering engine to the rudder-head of a ship, and has been already referred to in § 64. As applied to this purpose, the arrangement is as sketched in Fig. 184. The motion is transmitted from the steering engine through the toothed wheel

<sup>1</sup> Rankine's "Machinery and Millwork," 1st edit., p. 255.

<sup>2</sup> Perry's "Steam Engine," 1st edit., p. 493.

A to the toothed wheel B, keyed to the screw spindle C. The spindle C rotates in fixed bearings, and has on it a right- and left-handed screw. The nuts D and E work on the two screws, and are attached by the equal rods FG and HK to the rudder-head L. As B rotates, the nuts D and E separate by equal amounts—the pitches of the two screws being equal—and the tiller GH moves through a certain angle about the fixed axis L. But a difficulty here arises. Neglecting for the moment the nut E, for one revolution of B, D moves a certain distance to, say, the right, and LG turns through a certain angle. The arm LH moves through the same

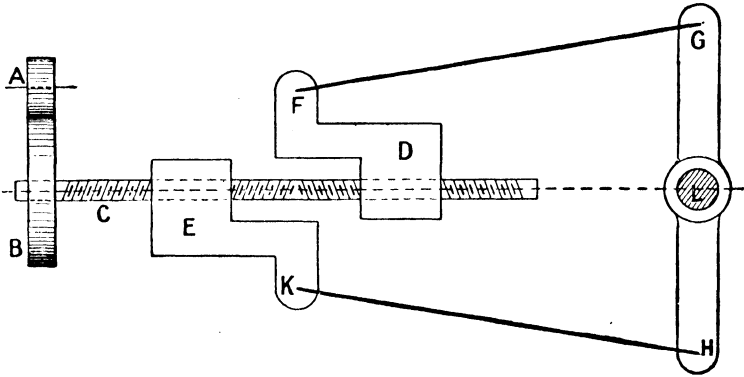

FIG. 184.

angle, and consequently the point K must suffer a definite displacement, depending on the proportions between the links, to the left. But the motion of the point K is also determined by the pitch of the screw C, and K is therefore subjected to two independent constraints; so that if, as has been tacitly assumed, the screw C rotates in fixed bearings and has no other freedom, the mechanism is locked, that is to say, motion is impossible. To overcome this difficulty, the screw C is allowed to have a slight motion in the direction of its axis, that is to say, from left to right.

The “shift” of the screw can be readily calculated if the dimensions of the mechanism are given. Thus, in Fig. 185, let the full lines denote the mean position of the mechanism, and the broken lines one of the extreme positions corresponding to a helm

angle  $\theta$ . Since FG and HK are equal, and the lines of stroke of F and K are at equal distances from the horizontal line through L, the obliquities of the rods FG, HK are the same when in the mean and also when in the extreme positions. Let the angles of obliquity in these two positions be  $\alpha$  and  $\beta$  respectively, and let  $l$  and  $a$  be the lengths of the connecting rods and tiller arm respectively. The displacement FF' of F, measured from its mean position, is clearly—

$$a \sin \theta - l(\cos \beta - \cos \alpha) \text{ to the right,}$$

and of K, namely, KK'—

$$a \sin \theta + l(\cos \beta - \cos \alpha) \text{ to the left.}$$

If the screw is prevented from moving axially, the displacements

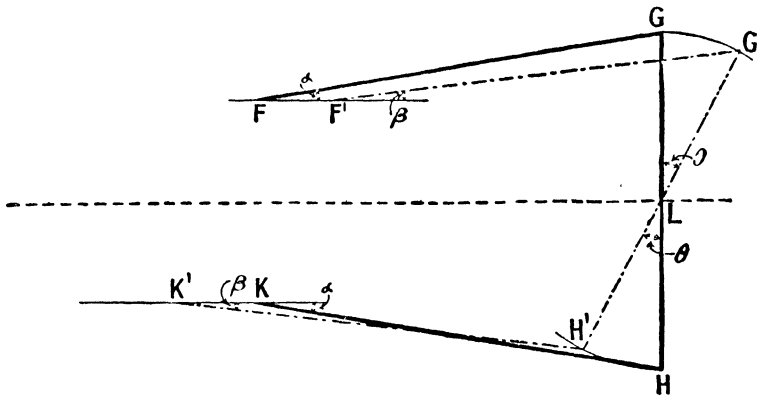

FIG. 185.

of the two nuts along it cannot therefore be equal, as they must be if the nuts work with the right- and left-handed screws; consequently, motion is impossible. But imagine the screw to move bodily in an axial direction to the left by the amount—

$$l(\cos \beta - \cos \alpha).$$

In that case, the points F' and K' will have moved the same distance—one to the right and the other to the left—relative to the same section of the screw, namely, the distance  $a \sin \theta$ ; so that, relative to a section of the screw, the displacement of the nuts

will be equal and opposite—a condition which agrees with the constraint of the right- and left-handed screw. The axial motion, or shift, of the screw spindle is, in practice, very small, and can be allowed for by allowing the wheel B (Fig. 184) to work on C by a feather, instead of by a fixed, key.

§ 117. **Toggle-joint.**—The mechanism of the direct-acting engine is used not only for the continuous transmission of motion and force, but also for intermittent motions. If, in Fig. 186, the crank pin be near its dead centre, the velocity ratio between the block B and the pin A (which is equal to  $OB/OA$ ) is very small, and becomes smaller and smaller the nearer the crank pin is to the dead centre. The consequence is that, when near this position, a comparatively large displacement of A produces a very small displacement of B;



FIG. 186.

so that a comparatively small force applied at A will overcome a considerable resistance at B. And when this mechanism is used intermittently, it is, in general, with the purpose of effecting this object. Mechanisms in which a considerable displacement of one point causes only a small displacement of a second point are frequently referred to as *toggle-joint*. The brake gears on waggons, etc., are a familiar illustration, and one or two others may be noticed.

§ 118. **Breech Mechanism of Guns.**—The most usual way of closing the breech is to use an interrupted screw. The breech block is furnished with a screw thread of the requisite pitch, fitting into a female screw in the gun (Fig. 187). The surface of the block may be divided longitudinally into six or eight equal parts, and the screw thread planed away from alternate portions. In the gun the parts corresponding to the smooth portions are left, and those between them slotted away. A turn of one-sixth or one-eighth of a revolution enables the block to be drawn out, and a carrier, hinged to the side of the gun, swings it clear of the bore. Most breech mechanisms are of the single-movement type, whereby one

motion of a hand-lever performs the separate actions involved in opening or in closing the breech. Moreover, to close or open the breech some type of toggle-joint is invariably used. A simple

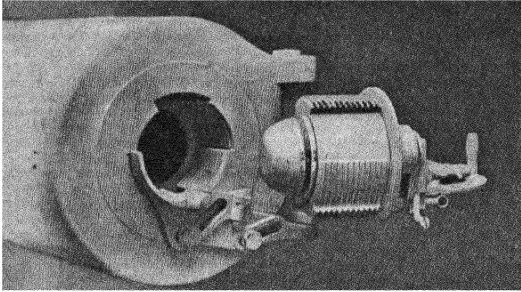

FIG. 187.

type is shown in Fig. 188. The breech block B is carried by the carrier C, which turns about a fixed fulcrum, F, attached to the gun. A pin, A, projecting from the breech block, is surrounded by

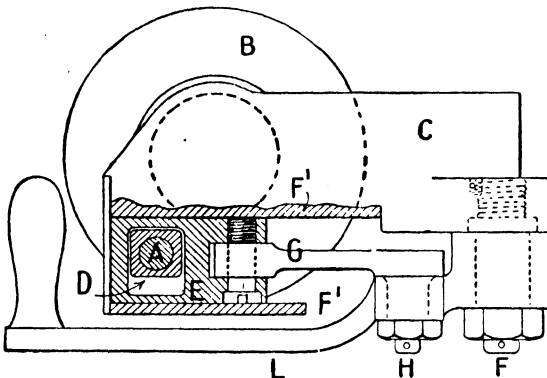

FIG. 188.

a piece, D, which can slide vertically in the piece E. The piece E slides in guides, F', attached to the carrier, and is connected by the rod G to a pin, H, which is attached to the action lever L, and the action lever turns about the fulcrum F. When the breech is closed, the lever L lies close up to the gun, and the pin H is practically on

its dead centre. The result is that when the lever is pulled, the piece E moves to the right, the piece D slides in E, and the breech block rotates; and a small force at the lever can overcome a considerable resistance at the breech screw. When the breech block is turned through the requisite angle, a catch holds it in position and prevents further rotation, with the result that the continued pull on the handle causes the carrier to rotate round F, and so swings the breech clear of the gun. One action thus locks or unlocks the breech plug and swings it in or out of the gun. The same action also actuates the firing gear, but on this point reference may be made to a paper by Lieut. Dawson, R.N., in the *Proceedings of the Institution of Mechanical Engineers* for July, 1901.

§ 119. **Pneumatic Riveter.**—A further illustration of a toggle-joint obtained by the use of the mechanism of the direct acting engine is shown in Fig. 189, as applied to a pneumatic riveter.<sup>1</sup> In that figure, A represents the frame, B the air-cylinder, C the piston, D the plunger die or dolly bar, and E the anvil die. F is the fulcrum of a bell-cranked lever, one arm,  $f_1$ , of which is connected to the piston C by the rod G, and the other arm,  $f_2$ ,

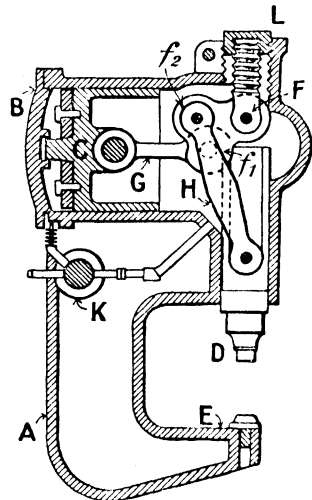

FIG. 189.

attached to the plunger die by the rod H, so that the mechanism virtually consists of the slider crank chain twice repeated. As the piston C moves to the right under the air-pressure, the turning moment on the bell-crank lever gradually increases, and the plunger die descends. As it nears the anvil die, the rod H and the arm  $f_2$  of the bell-crank lever become nearly in one line, so that the plunger die descends very slowly, and a very great pressure is applied during the latter stages of closing up the rivet. Each side of the piston C is alternately put into communication with

<sup>1</sup> From the *Mechanical Engineer*, June 9, 1900.

the high-pressure air and with the atmosphere by means of a two-way cock at *K*. It will be noticed that the fulcrum *F* is carried at the end of a spindle screwed into the cap *L*; and the object of this arrangement is so that the fulcrum *F* may be adjusted in a vertical direction in order that different-sized plates may be put in the machine.

Other illustrations of toggle-joints are described in §§ 122, 132, 133, 134.

(2) *Crank and Slotted-lever Mechanism.*

§ 120. **Oscillating Cylinder.**—In the mechanism of the slider-crank chain so far discussed, the fixed link is the link which is common to a sliding pair and a turning pair. Next, suppose the fixed link is common to two turning pairs, so that the fixed link may either be the connecting-rod *AB*, or the crank arm *PA*. Consider, first, the mechanism obtained by fixing the connecting-rod, a diagrammatic sketch of which is shown in Fig. 190. A

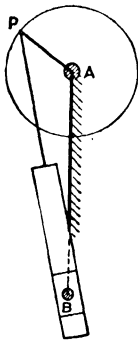

FIG. 190.

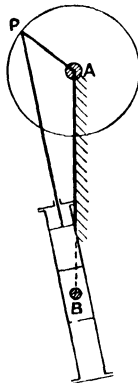

FIG. 191.

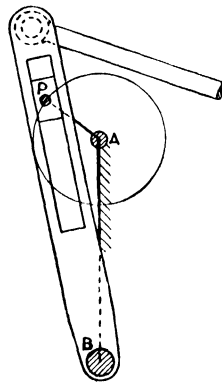

FIG. 192.

motion of continuous rotation of the arm *AP* about the axis *A* causes a motion of oscillation of the block about the axis *B*. Without altering the character of the chain, the oscillating body

may be made hollow (Fig. 191), in which case the mechanism is that of the *oscillating cylinder engine*. The oscillating body is the cylinder, which oscillates about a trunnion at B, and the piston rod is directly connected to the crank pin P, the crank shaft being at A. The steam-pressure, acting alternately on the two sides of the piston, causes the crank shaft to continuously rotate, and the cylinder itself to oscillate to and fro.

§ 121. **Crank and Slotted Lever. Quick-return Motion. Curves of Velocity.**—A third constructive modification of this mechanism is shown in Fig. 192. When constructed as shown in this figure, the mechanism is sometimes called the *crank and slotted-lever mechanism*. The driver is then the crank arm AP, and the follower is the oscillating lever of centre B. A diagrammatic sketch is shown in Fig. 193. The extreme positions of the lever are obtained by drawing tangents from B to the crank-pin circle, touching that circle at the points  $P_1$  and  $P_2$ . As the lever swings from the position  $BP_1$  to the position  $BP_2$ , the crank pin moves over the arc  $P_1CP_2$ ; and as the lever swings back from the position  $BP_2$  to  $BP_1$ , the crank pin moves over the arc  $P_2C'P_1$ . Thus, assuming that the shaft A rotates uniformly, the ratio of the times occupied by the lever in performing the two swings is equal to the ratio of the angles which the arcs  $P_1CP_2$  and  $P_2C'P_1$  subtend at the centre A; and this mechanism can, therefore, be used to give a quick-return motion to the ram of a shaping machine by connecting the ram R to a pin, Q, in the oscillating lever by means of a connecting-rod, QR, as shown. The extreme positions of the pin Q are  $Q_1, Q_2$ , and of the ram  $R_1, R_2$ , found by making  $Q_1R_1 = QR = Q_2R_2$ . The cutting stroke is from right to left, and the home stroke from left to right, and the time ratio of the two strokes is the ratio just given.

To obtain the velocity of the ram in any position, such as R, in the cutting stroke, the velocity of Q, and therefore the angular velocity of the lever BQ, must first be known. The latter can be found graphically by the construction given in § 108, where it is shown that if PK be drawn perpendicular to BP to meet the line of centres, produced if necessary, in K, then—

$$\frac{\text{angular velocity of BQ}}{\text{angular velocity of AP}} = \frac{AK}{KB};$$

hence if  $\omega$  is the uniform angular velocity of AP, the angular velocity of the lever is  $\omega \cdot \frac{AK}{KB}$ . The linear velocity of Q is, therefore,  $\omega \cdot \frac{AK}{KB} \cdot BQ$ , and of P,  $\omega \cdot AP$ ; whence the linear velocity

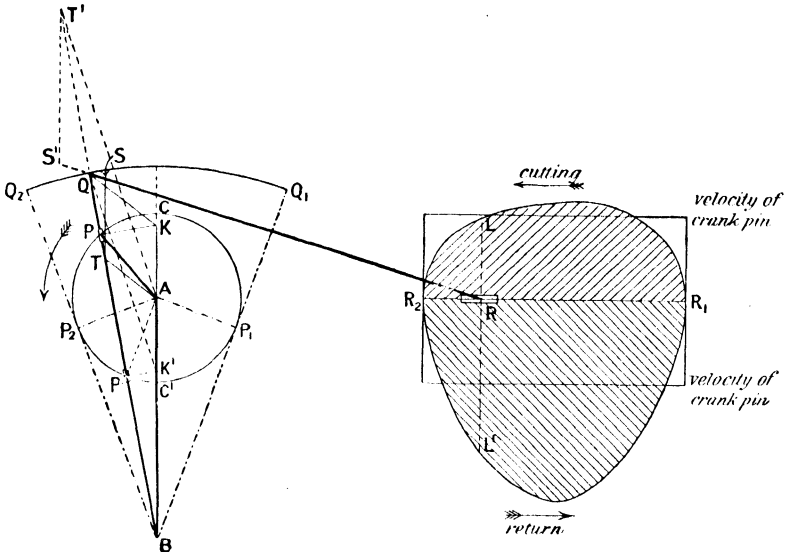

FIG. 193.

ratio of Q and P is  $\frac{AK}{KB} \cdot \frac{BQ}{AP}$ . If KQ be joined, and AT be drawn parallel to it to meet BQ in T, this ratio becomes  $\frac{QT}{QB} \cdot \frac{BQ}{AP}$ , that is to say,  $\frac{QT}{AP}$ ; consequently, QT will represent the linear velocity of Q on the same scale that AP represents the linear velocity of P. The velocity of the ram is then obtained by drawing TS perpendicular to the stroke to meet the connecting rod in S; the length TS will represent the velocity of the ram on the same scale that AP represents the velocity of the crank pin.

When the ram is in the position R in the return stroke, the

crank pin is at P', and the velocity of the ram is represented by T'S', obtained by repeating the construction.

By proceeding in this way, curves of velocity of the ram may be drawn for both the cutting and return strokes. In the figure, the velocity of the crank pin P is represented by the horizontal lines, the height of which is equal to the crank radius; and, in the position of the mechanism sketched, the velocity of the ram in the cutting stroke is represented by RL, which is equal to TS. When the ram is at R in the return stroke, the velocity is RL' made equal to T'S'; so that the upper curve refers to the cutting stroke from right to left, and the lower curve refers to the return stroke from left to right. The construction fails when the crank and lever are vertical, and in these positions the velocity of the ram must be obtained differently. The maximum angular velocity of the lever in the cutting stroke occurs when the pin coincides with C, and in that position the angular-velocity ratio of the lever to the crank is  $\frac{AC}{CB}$  and consequently the linear-velocity ratio of Q to the crank

pin is  $\frac{AC}{CB} \cdot \frac{BQ}{AP} = \frac{BQ}{CB}$ . If the stroke of the ram be perpendicular to the line of centres AB, the velocity of the ram, when the crank is vertical, is equal to the velocity of Q, and this may generally be taken as the maximum cutting velocity of the tool. The maximum angular velocity of the lever in the return stroke occurs when P coincides with C', and the ratio is then  $\frac{AC'}{C'B}$ , the linear-velocity ratio of Q to the crank pin being  $\frac{BQ}{BC'}$ .

When this mechanism is used as a quick-return motion for a shaping or slotting machine, it is generally in the form shown in Fig. 192. The pin P turns in a block, which slides in the slot in the lever. It is not, however, attached to a crank arm of invariable length, but to a second block, which rests in a diametral slot in a plate or wheel which is keyed to the spindle A, the plate or wheel being driven by gearing and belting. The stroke is varied by altering the position of the block in the diametral slot. Bringing the block nearer to the centre reduces the stroke, and also makes

the times of cutting and return more nearly equal; and with the same revolutions of the driving shaft, the time per double stroke is unaltered.

**§ 122. Toggle Joint for a Brick Press.**—An interesting application of the crank and slotted lever in combination with the toggle joint described in § 117 occurs in some brick presses. The brick press, illustrated in Fig. 194,<sup>1</sup> is designed to make bricks from any kind of clay which will grind through a perforated pan. Such clay is semi-dry, and is powdered. The powdered clay is fed by a charger into a mould, in which it is strongly compressed by rams working both from above downwards, and also from below upwards. When the mould is first filled, it contains, in addition to the clay, a quantity of air enclosed within the interstices of the plastic material. When pressure is applied, this air is forced out, but it cannot escape from the mould, the openings of which are filled by the rams. The pressure is, therefore, momentarily relaxed to allow the air to get away, and then the pressure is renewed to finally consolidate the clay and produce a solid, sharp-edged brick. It is in the means of obtaining these two pressures that the chief interest, from our point of view, lies.

The general view of the machine is shown in Fig. 194, and Figs. 195–198 show the mechanism for obtaining the two pressures. Pivoted to the wheel A is a slotted bar, B, and in the slot is a pin, C, which forms the extremity of one arm of the bell-crank lever CDE (Fig. 195), which turns on a fixed fulcrum at D. The pin E is attached to the ram by the rod EF, the line of stroke of the ram passing through D. This toggle actuates the upper ram, whilst the lower ram is actuated by long coupling rods (shown in Fig. 194), which are attached to a third arm in the bell-crank lever. Confining our attention to the upper ram, the slotted bar B is provided with two stops, G and H, so that the motion of rotation of the wheel A is only transmitted to the bell-crank lever provided the pin C is against one or other of the stops; consequently a period of rest is provided, during which the pressed brick is pushed away by the charger and a fresh supply of clay is introduced to the moulds. As the wheel A continuously rotates, all the

<sup>1</sup> See *Engineering*, February 22, 1901.

necessary operations are performed. In Fig. 195 the rams are wide apart, and remain so until the crank has moved into the

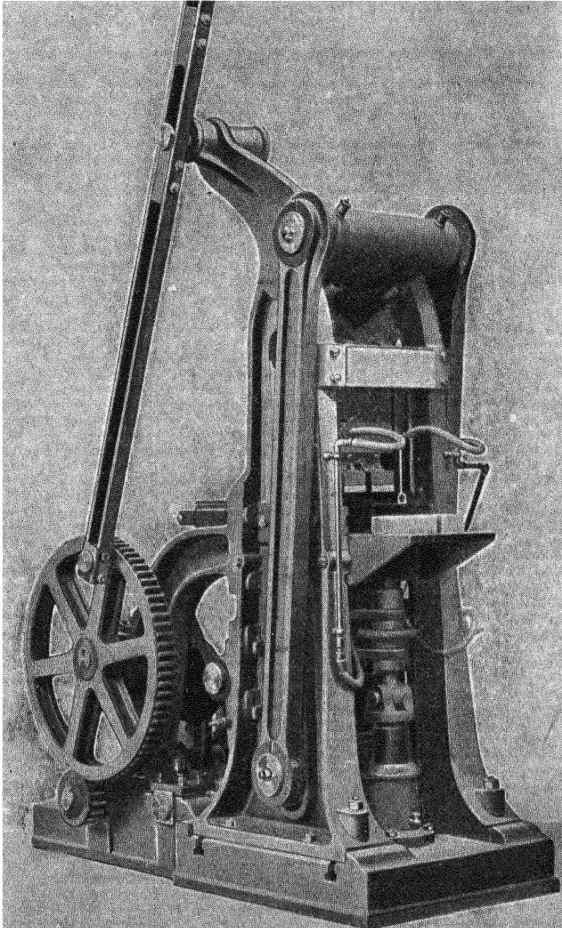

**FIG. 194.**

position shown in Fig. 196, that is to say, until the top stop H comes into contact with the pin C. The lever CD is then drawn down until the toggles become quite straight, as shown. The

continued rotation of the wheel carries the arm DE past the centre line (Fig. 197), and then there comes a second period of rest, while the slotted link slips over the pin from the position

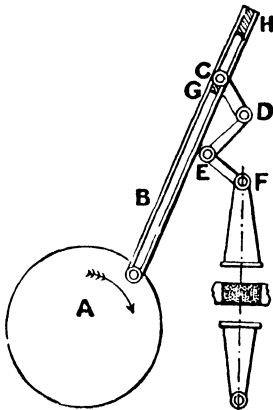

FIG. 195.

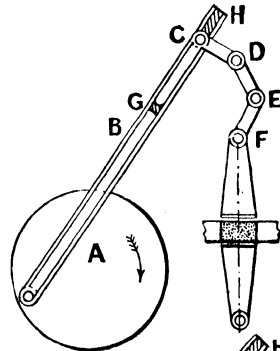

FIG. 197.

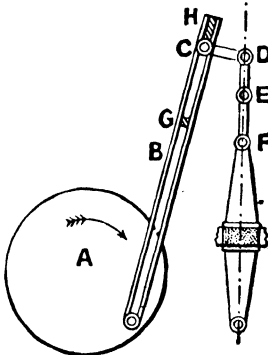

FIG. 196.

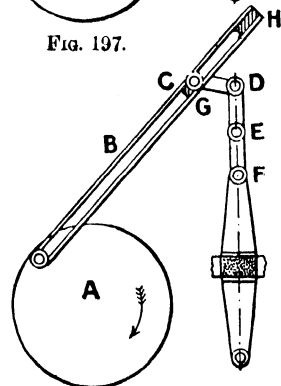

FIG. 198.

shown in Fig. 197 to nearly that represented by Fig. 198. During this period the pressure is released and the air escapes. The toggle is again straightened, and so the clay is consolidated; and a further movement of the crank pin lifts the rams clear of the mould. The bricks are pushed out of the moulds by a ram arrangement which it is not necessary to describe.

(3) *The Pin-and-slot Mechanism.*

In the crank and slotted-lever mechanism, the fixed link is common to two turning pairs, one turning pair rotating continuously in one direction, and the other oscillating to and fro through a certain angle. If the crank arm be fixed, the fixed link will still be common to two turning pairs, but both turning pairs will now rotate continuously in the same direction.

§ 123. **Coupling between Two Parallel Shafts. Curves of Angular Velocity.**—A diagrammatic sketch of this mechanism—known as the *pin-and-slot mechanism*—is shown in Fig. 199. The arms AB and PQ both rotate continuously in the same direction about the centres A and P; and, as rotation takes place, the block B slides in a slot in the arm PQ. The mechanism might therefore be used as a coupling to connect two parallel shafts; but when used for this purpose, the angular-velocity ratio transmitted is not constant, but varies from moment to moment. When PQ occupies the positions (indicated by broken lines) perpendicular to the line of centres, the arm AB occupies the positions AB<sub>1</sub>, AB<sub>2</sub>, and, consequently, as the arm PQ describes the upper half of its circle, the pin B traces out the arc B<sub>1</sub>C'B<sub>2</sub>, and whilst PQ describes the lower half of its circle, B traces out the arc B<sub>2</sub>CB<sub>1</sub>. If AB rotate at a uniform rate, PQ will thus have a variable angular motion impressed upon it.

To find the angular-velocity ratio of the shafts P and A for any position of the mechanism, draw BK perpendicular to the direction of the slot to meet the line of centres in K, so that (§ 108)—

$$\frac{\text{angular velocity of P}}{\text{angular velocity of A}} = \frac{KA}{KP}$$

If the shaft A rotate at a uniform rate, it is convenient to express the denominator of this fraction by a constant length, and one way of doing so is to draw AM parallel to KB, and ML parallel to PA. Then—

$$\frac{KA}{KP} = \frac{MB}{BP} = \frac{BL}{BA}$$

Thus, if  $AB$  represent the constant angular velocity of  $AB$ ,  $BL$  will, on the same scale, represent the variable angular velocity of  $PQ$ .

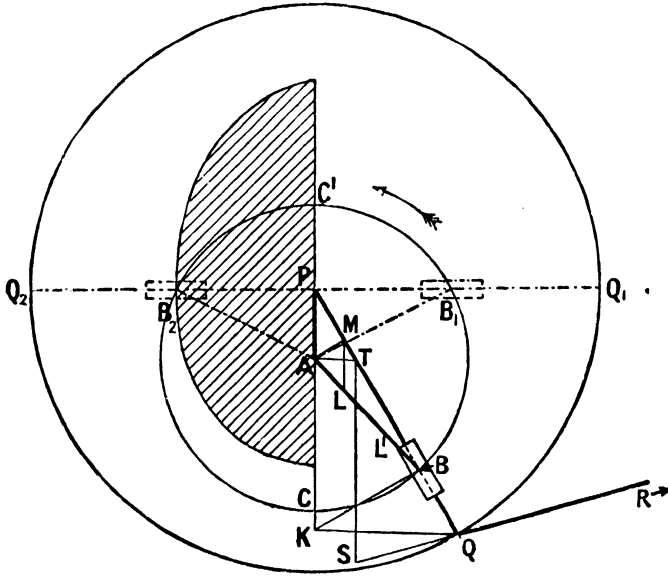

FIG. 199.

The maximum and minimum angular velocities of the arm  $PQ$  take place when  $B$  coincides with  $C'$  and  $C$  respectively, and the angular-velocity ratios between the shafts  $P$  and  $A$  are then  $\frac{AC'}{PC'}$  and  $\frac{AC}{PC}$  respectively—being greater than unity in the former, and less than unity in the latter, position. When the lever  $PQ$  is perpendicular to the line of centres, that is to say, when  $B$  occupies the positions  $B_1$  and  $B_2$ , the angular-velocity ratio is unity, as may be readily seen by repeating the general construction given above for these positions. Thus, although the mean angular velocity of  $PQ$  and  $AB$  is the same for every half-revolution, the actual ratio is alternately greater and less than unity. A curve showing this variation may be readily drawn by marking off along

AB a length AL' equal to LB ; so that on the same scale that the radius of the circle described by B represents the angular velocity of the shaft A, the polar distance AL' will represent the angular velocity of the shaft P. If this construction be repeated for a number of positions of the mechanism, the curve joining the points L' so obtained will be a polar curve of angular velocities. To prevent confusion, only half the curve has been drawn, namely, the shaded curve on the left.

It may be noticed that the pin-and-slot mechanism may be used to transmit a constant angular velocity to two parallel shafts provided the crank radius AB is equal to the distance between the centres (Fig. 199). With this arrangement the angle CAB is always twice the angle APP, and the shaft A rotates as fast as P.

§ 124. Whitworth Quick-return Mechanism

This mechanism is readily adapted as a quick-return mechanism by connecting a pin placed on the connecting-rod QR. If the stroke of the rod is the line of centres PA, and, when produced, the length of the stroke will be equal to the length of the stroke of the crank. The times taken in the cutting and return strokes are in the ratio of the angles which the connecting-rod makes at the centre A ; but if the connecting-rod does not pass through P, or is not perpendicular to PA, two positions must be obtained. To find the linear velocity of the pin, the mechanism, it must be assumed that the angular velocity of AB, the ang

linear-velocity ratio

$\frac{QT}{AB}$ , where AT is the perpendicular distance from A to the line of centres (as in § 121). Thus the linear velocity of the pin B, QT will be equal to the angular velocity of the crank AB and the velocity of the pin represented by TS,

stroke to meet the connecting-rod in S. The curves of linear velocity of the ram may therefore be drawn, both for the cutting and return strokes, as in the crank and slotted lever. The maximum cutting velocity—which is the most important velocity to determine—may be very approximately taken to be equal to the velocity of Q in its lowest position.

When this mechanism is applied in practice to shaping machines, it is usually in the form shown in Figs. 200 and 201, which represent a longitudinal section and front elevation respectively. A slotted wheel, E, provided with teeth, rides loosely over a pinion, F, on the machine shafting. A connecting-rod, R, is caused to rotate by the pinion F, and is attached to a T-headed pin, P, which works in the slot of the wheel E. From the face of A, which works in the boss of the slotted

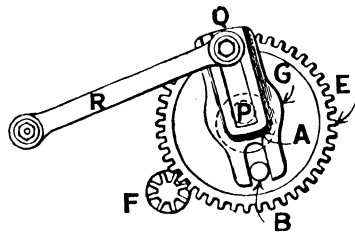

FIG. 201.

From the wheel E a fixed arm. The connecting-rod R is attached to the wheel E by means of a T-headed pin P, which works in the slot of the wheel E. With the rotation of the wheel E, the cutting stroke of the ram is from left to right.

In the Whitworth quick-return mechanism, the position of Q in the lowest position provided the line of

The slotted-lever mechanism is, in various forms, mechanisms consisting of a variety of forms for the purpose of coupling and as a means of converting the motion of AB is the driver),

but it is also used in air drills, in hydraulic machines, and in rotary engines. A few modern applications may not be out of place.

The pin-and-slot mechanism is the mechanism adopted in the "Little Giant" high-speed drill. Fig. 202 represents a section through the cylinders. It consists of a casing, *Q*, to which are rigidly attached three cylinders, *C*, set at  $120^\circ$  with each other. Each cylinder is provided with a piston, *B*, and all three connecting-rods lay hold of the same pin or stud, *A* which is fixed; whilst the casting carrying the cylinders is free to rotate about a second fixed stud, *P*. Kinematically, each cylinder, piston, and connecting-rod form a mechanism which is the same as that of Fig. 199,

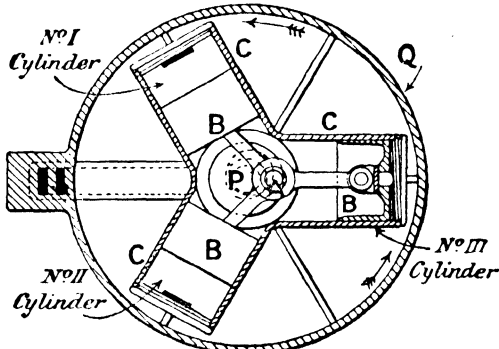

FIG. 202.

in which the block sliding over the link *PQ* is replaced by the pistons sliding in the cylinders—the mechanism simply being repeated as in a multiple-cranked engine. The cylinders are single acting, and the high-pressure air acts on the end of the piston farthest from the stud *A*; whilst the exhaust air is discharged in the central chamber in which the studs *A* and *P* are placed. The air is alternately admitted and discharged from each cylinder by piston valves which rotate with, and work in valve chambers forming part of, the main engine cylinders. The result is that if the high-pressure air act on No. 1 piston, say, it would, if the cylinders were fixed, cause the crank arm *PA* to rotate clockwise; hence, if the crank arm is fixed, the cylinders must

rotate counter-clockwise. Or, to look at it differently, the connecting-rod is in a state of compression, and will consequently exert a force on the sides of the cylinder—corresponding to the pressure on the guides in an ordinary engine—which will cause the casting carrying the cylinders to rotate counter-clockwise. It will, of course, be noticed that No. 2 cylinder is exhausting, and No. 3 cylinder just about to receive high-pressure air. The drivers in this case are the pistons, and the follower is the casing *Q*, which rotates about *P*. The drill spindle rotates with the casing, and the advance of the drill may be obtained by any of the mechanisms described in §§ 59, 60 and 61; but on this point, and also on points connected with the valves, reference may be made to a paper by Mr. Amos in the *Proceedings of the Institution of Mechanical Engineers* for February, 1900.

§ 126. **Rigg's Hydraulic Engine.**—A further illustration of the pin-and-slot mechanism is Rigg's hydraulic engine, illustrated in

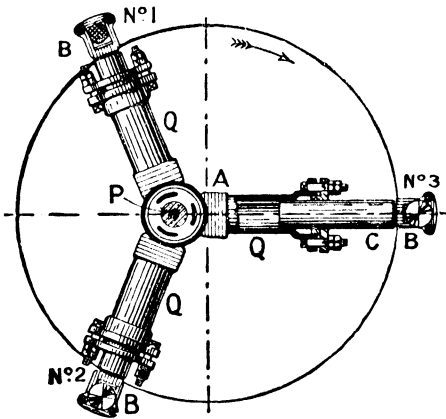

FIG. 203.

Fig. 203. The three cylinders *Q* are cast in one piece with a circular valve which revolves on a stud, *P*; and the plungers *C*, instead of being connected to the second fixed stud *A* by means of three equal connecting-rods, oscillate on the pins *B*, which are attached to a disc which rotates about *A*, so that the mechanism is again the pin-and-slot mechanism modified constructively.

The working side of the plunger is, of necessity, the side nearest to *A*. The water is admitted and discharged through openings in the circular valve, the shaft *P* being hollow to allow this to be done. The action is precisely the same as in the previous case. The high-pressure water acting on No. I. plunger would cause, if the cylinders were fixed, the crank arm *AP* to rotate about *P* in a

counter-clockwise direction ; consequently, when the crank arm is fixed, the cylinders must rotate about P in a clockwise direction. In the position shown, No. II. cylinder is exhausting, and No. III. cylinder just about to exhaust. The stroke of the plungers in the cylinders is twice the distance AP ; and the great advantage of this arrangement is that—since the high-pressure water is, of necessity, admitted throughout the stroke—the working at low loads may be made economical by reducing the stroke ; and this can readily be done, whilst the engine is working, by altering the distance AP. The method adopted in practice for effecting this alteration, by means of a relay engine, will be found described in works on hydraulic machinery.

§ 127. **Bradford Air-drill.**—Constructively, the mechanism of the Bradford air-drill is quite different from the two previous cases,

although kinematically it is identical. It serves also as an example of what is frequently known as a rotary engine. In its simplest form, the mechanism is shown in Fig. 204, which represents a section. C is a fixed cylindrical casing of centre A having plane ends, and D is a cylinder which is free to turn about its centre, P, and which is provided with plane ends to correspond with the plane ends of the casing. A flat plate or shutter, E, having a length the same as that of the casing, slides in a diametral slot in the cylinder D, and is kept in contact with the casing C by means of the link AB. The passage L is in constant communication with the high-pressure air, and the passage M is likewise in permanent communication with the atmosphere. The result is that the high-pressure air, pressing on the plate E, causes the cylinder D to rotate, and so causes rotation of the drill spindle. The mechanism is identical, kinematically, with the pin and slot,

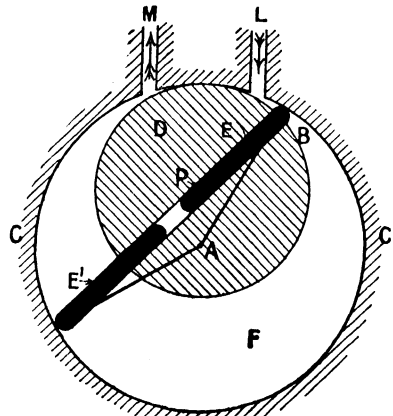

FIG. 204.

but in this case the driver is the plate E, and the follower the cylinder D. If only one plate be used, when E passes the passage M there will be direct communication of the high-pressure air with the atmosphere; and to prevent this, a double plate or piston, E', is employed. The air contained in the space F, which is not in communication either with the high-pressure air or the atmosphere, will undergo alteration in volume as rotation takes place, and will consequently expand; and thus the air is alternately admitted, expanded, and discharged as in the ordinary type of engine. Moreover, with two pistons, the connecting-rods AB may be dispensed with, provided a compressed spring is placed in the diametral slot between the pistons (Fig. 205), thus pushing the pistons out against the casing. A more detailed description of

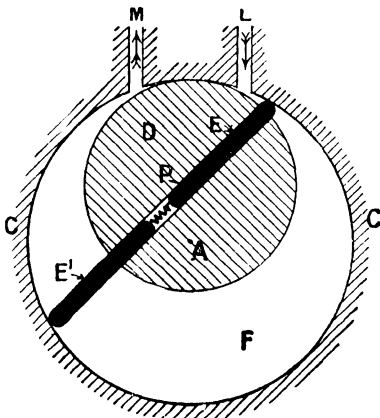

FIG. 205.

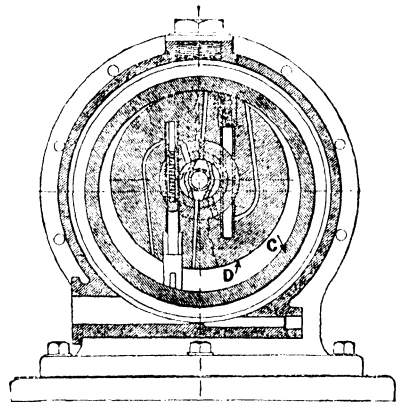

FIG. 206.

this drill, which has the advantage of great simplicity due to the absence of valves, will be found in *Engineering* for June 11, 1897.

§ 128. **Hult's Rotary Steam-engine.**—A final illustration of a pin-and-slot mechanism which may be noticed is Hult's rotary steam-engine, which in many respects is similar to the previous one. In the Bradford drill, the pistons and cylinder D have sliding contact with the casing C; consequently the friction is excessive. In Hult's rotary engine, the cylinder D and casing C are made to rotate, by means of gearing, at the same circumferential speed.

There is thus no sliding contact between the cylinder and casing, and, since the pistons and casing are moving in the same direction, the sliding velocity and consequent loss in friction is much reduced. But the rotation of the casing necessitates a more complicated arrangement of passages, and a section of Hult's engine is shown in Fig. 206. The steam enters at the axis of the cylinder D, which is made hollow for the purpose, and, by means of ports in a rotary valve, is alternately admitted, expanded, and discharged. A full description will be found in *Engineering* for December 24, 1897.



#### (4) *Four-bar Chain.*

§ 129. The four-bar chain consists of four elements and four turning pairs. Whichever link is fixed, the mechanism transmits a rotary motion from one shaft to a parallel shaft. If the proportions of the mechanism are such that both shafts continuously rotate in the same direction, the combination is usually termed a *double-crank* or *drag-link mechanism* (the mechanism of feathering paddle wheels, § 111, is an illustration); if one shaft continuously rotate and the second oscillates to and fro through a certain angle, it is called a *lever-crank* mechanism (the beam-engine mechanism, § 90, is an illustration); and if a motion of oscillation of the one shaft causes a motion of oscillation of the second, it is called a *double-lever* mechanism (the mechanism of Watt's parallel motion, § 86, is an illustration). When used for power purposes, one at least of the moving links is a crank.

§ 130. **Lever-crank Mechanism. Curves of Velocity.**—Fig. 207 refers to a lever-crank mechanism, the crank being  $P_1A$  and the lever  $P_2B$ . The extreme positions of B are  $B_1$  and  $B_2$ , obtained by describing arcs of centre  $P_1$  and radii equal to  $AB \pm P_1A$  to meet the path of B; and the corresponding positions of A are  $A_1$  and  $A_2$ . As the lever swings from right to left, the pin A moves over the arc  $A_1CA_2$ , and as it swings back again from left to right, the pin A moves over the arc  $A_2C'A_1$ . If the crank rotate uniformly, the times of the two swings are not therefore the same, but are proportional to the angles which these arcs subtend at the centre  $P_1$ . To find the linear-velocity ratio between B and A, or the angular-velocity ratio between the

shafts  $P_2$  and  $P_1$ , draw  $P_1N$  parallel to  $P_2B$  to meet the coupler, produced if necessary, in  $N$ ; then (§ 107)  $P_1N$  may be taken to represent either the linear velocity of  $B$  or the angular velocity of  $P_2$  on different scales—the scale of linear velocity being such that  $P_1A$  represents the linear velocity of  $A$ , and the scale of angular velocity such that  $P_2B$  represents the angular velocity of  $P_1$ . To draw curves of velocity, mark off a distance  $BL$  equal to  $P_1N$  along the direction of the lever, and repeat the construction

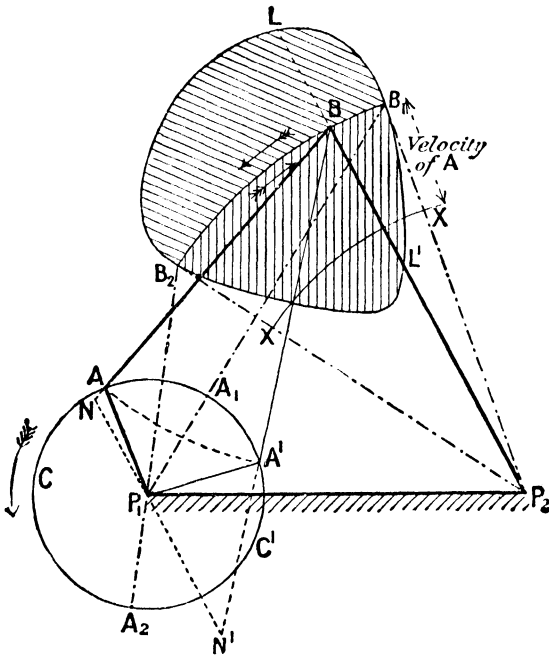

FIG. 207.

for a number of positions. When the lever is swinging from left to right and occupies the position  $B$ , the corresponding position of the crank is  $A'$ , and the velocity is represented by  $P_1N'$ , so that  $BL'$  is made equal to  $P_1N'$ . The general shape of the curves is as shown, the upper curve referring to the swing from right to left and the lower curve from left to right. The radial distance of the line  $XX$  from  $B_1B_2$  is equal to  $P_1A$ , and if the diagrams be curves

of linear velocity of B, that distance will represent the linear velocity of A; but if the curves be curves of angular velocity, the scale is such that  $P_2B$  represents the angular velocity of  $P_1$ .

If the mechanism be a double crank, we may follow exactly the same method, but the curve of velocity will now lie entirely outside the path of B, denoting that its direction of motion does not change.

§ 131. **Application to Toggle Joints—Stanhope Levers.**—The four-bar chain is used for a variety of purposes, such as, for example, a coupling to connect two parallel shafts, for the mechanism of feathering paddle wheels, for parallel motions, etc.; and it is also used as a toggle joint, that is to say, as a mechanism for obtaining a very great reduction in velocity ratio. Thus in Fig. 208, let the coupler AB and the crank  $P_1A$  be very nearly, but not quite, in the same line. The angular-velocity ratio of  $P_2$  to  $P_1$  is then equal to  $KP_1/KP_2$ , and is therefore small, and becomes smaller the more nearly  $P_1A$  and AB lie in one line. A comparatively small turning moment applied to the shaft  $P_1$  can thus overcome a large resistance at the shaft  $P_2$ . The mechanism, when used for this purpose, is usually known as the *Stanhope levers*, and, as such, is applied to hand presses, carriage brakes, breech mechanisms, stone-crushing machines, etc.

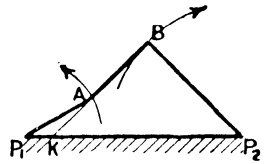

FIG. 208.

§ 132. **Hand Press.**—As applied to a hand press, the arrangement is shown in elevation and plan in Figs. 209, 210. The screw of the press works in a nut,  $P_2$ , which forms the boss of the arm  $BP_2$ , and the nut is rotated, through the four-bar chain  $P_1ABP_2$  from the handle  $P_1H$ , which turns about a fixed centre,  $P_1$ , in the frame of the machine. When approaching the configuration shown in the plan, a very large pressure is exerted at the press plate by the application of a comparatively small force at the handle.

§ 133. **Rubber-stoppered Bottles.**—A further familiar illustration of a toggle joint is the arrangement sometimes adopted for rubber-stoppered bottles, a sketch of which is given in Fig. 211. The

neck of the bottle is represented by C, and the stopper, which is provided with a rubber washer, by D. The centres  $P_1$  and  $P_3$  are

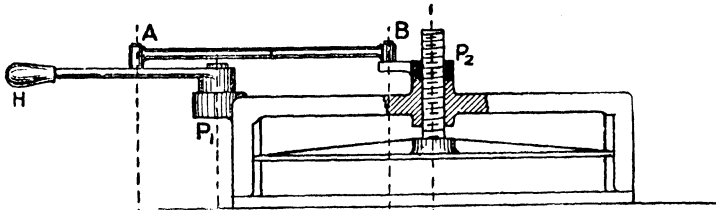

FIG. 209.

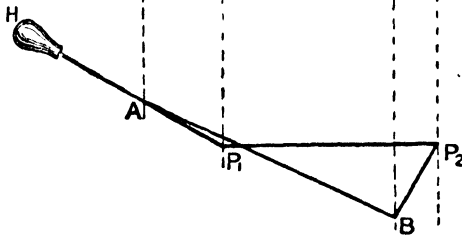

FIG. 210.

fixed, and the stopper is pivoted at  $P_2$  to the extremity of a stout wire, which can be swung round  $P_3$ ; whilst a looped wire (which can be readily disengaged)

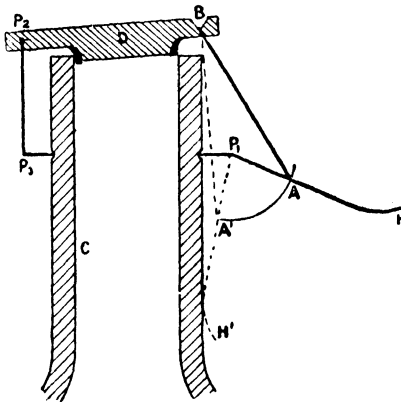

FIG. 211.

engages the other end of the stopper at B and is pivoted to a lever,  $P_1H$ , turning about  $P_1$ . When the stopper is on the bottle,  $P_2$  is practically a fixed centre, so that the mechanism is the four-bar chain  $P_2BAP_1$ ; and at the moment of closing,  $P_1A$  and  $BA$  are practically in one straight line, so that a small force applied at H exerts a large pressure on the rubber washer. When

finally closed, the link  $P_1H$  lies against the neck of the bottle, and A lies to the left of  $P_1$  (as shown by  $P_1A'H'$ ); and the

elasticity of the washer causes the lever  $P_1H'$  to press against the bottle. The stopper is therefore locked, and can only be opened by applying an outward force to  $P_1H'$ .

§ 134. **Stone-crushing Machine.**—An application of this toggle joint to a stone-crushing machine is illustrated in Fig. 212.<sup>1</sup> The

frame A is surmounted by the hopper B, into which the stones are fed. The crank shaft C runs across the top of the frame, and to the crank arm is attached the arm D, to which is attached a lever, E, turning on a fulcrum, F, which is journaled in the frame. To the end of E is attached the link G, which is also attached to one end of the link H, the other end of H turning on a pivot in the frame. The link or "push-plate" H operates the crushing jaw J. When the crank arm is vertical the jaws are opened, but after a time the links F and G fall in the same line, and so H can exert a very great pressure on the jaws. There are two positions of the crank for which this condition is satisfied. The mechanism is frequently duplicated in order to actuate a jaw to the right, as shown by the faint lines.

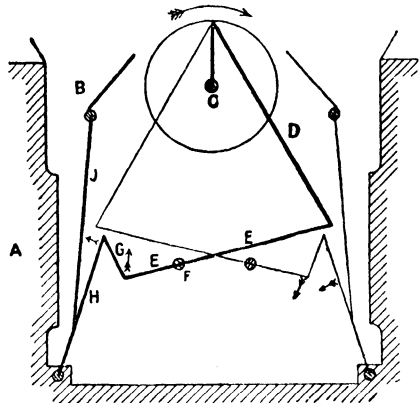

FIG. 212.

§ 135. **Hooke's Joint. Curves of Velocity.**—By means of the four-bar chain, consisting of four turning pairs, a motion of continuous rotation may be transmitted between two parallel shafts, and the angular-velocity ratio will vary from moment to moment.

If the shafts are not parallel, but intersect, a motion of continuous rotation may still be transmitted from one to the other by the mechanism known as Hooke's joint, which also consists of four links and four lower pairs. In the four-bar chain (Fig. 207), the axes of all the turning pairs are parallel; or, in other

<sup>1</sup> From the *Mechanical Engineer*, January 7, 1899.

words, they intersect at infinity. In Hooke's joint, they intersect at some finite point  $O$ , as shown in Fig. 213, and the axis of  $A$  and  $B$  then trace out cones instead of cylinders. In fact, Hooke's joint bears the same relation to the four-bar chain that bevel wheels do to spur wheels. The angular-velocity ratio of the two shafts varies from moment to moment, and the object is to get the velocity ratio at any instant.

The most familiar form of Hooke's joint is shown in Fig. 214. At the ends of the two shafts  $P_1$  and  $P_2$  are keyed a pair of forks which carry the bearings in which the equal arms of a rigid rectangular cross can rotate. The arms of this cross intersect in the point of intersection of the shafts, so that the condition that

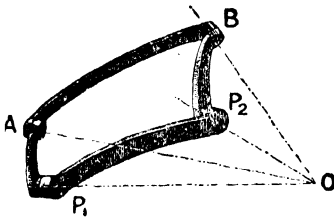

FIG. 213.

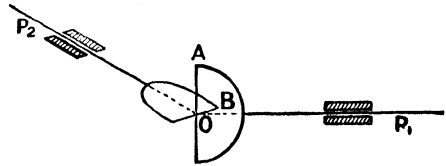

FIG. 214.

the axes of the four turning pairs should pass through the same point  $O$  is satisfied.

To get the position of the second shaft corresponding to any position of the first, the arms  $OA$  and  $OB$  may be projected on a plane perpendicular to the axis of the first shaft. The projection of the path of  $A$  will be a circle, and of  $B$  an ellipse whose semi-major axis is equal to the length of the arm, and whose minor axis is equal to the length of the arm multiplied by  $\cos \alpha$ , where  $\alpha$  is the angle between the planes of the circles described by  $A$  and  $B$ , that is to say, the angle of inclination of the two shafts. Moreover, since the arms are perpendicular to each other, and are projected on a plane parallel to one of them, their projections are also perpendicular; consequently if, in Fig. 215,  $OA$  be the projection of the first arm,  $OB$  will be the projection of the second arm where  $AOB$  is a right angle—the curve passing through  $A$  being a circle, and through  $B$  an ellipse. Thus, whilst the projection of

the first arm moves from the position  $OA_0$  to the position  $OA$ , that of the second arm moves from  $OB_0$  to  $OB$ . Now, the angle turned through by the first shaft from the position  $OA_0$  is actually the angle  $A_0OA$  (say  $\theta$ ); but the angle  $B_0OB$  is not the angle turned through by the second shaft from the position  $OB_0$ , but is only the projection of that angle. The true angle turned through

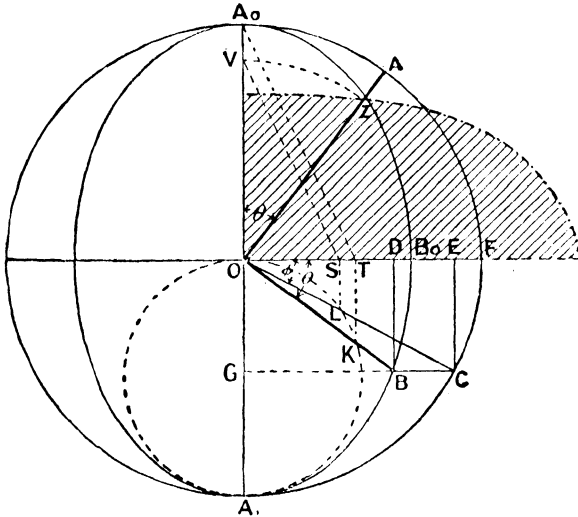

FIG. 215.

by the second shaft is clearly the angle  $FOC$  (say  $\phi$ )— $C$  being the point where a line through  $B$ , drawn parallel to  $OB_0$ , cuts the circle. This is evident when it is remembered that the vertical descent of the extremity of the second arm below the line  $OF$  is, accurately,  $BD$ , and that the radius of the circle which it describes is  $OC$ . Thus, then, the *average* angular velocity ratio of the two shafts (that is, of the second to the first shaft) is  $\frac{\phi}{\theta}$ , and is the same for every quarter of a revolution. The actual angular velocity ratio in the position shown is  $\frac{\delta\phi}{\delta\theta}$ , and the value of this expression may be found as follows:—

$$\begin{aligned}\tan \theta &= \tan \text{ DOB} = \frac{\text{DB}}{\text{OD}} \\ \tan \phi &= \tan \text{ EOC} = \frac{\text{CE}}{\text{OE}} \\ \therefore \frac{\tan \phi}{\tan \theta} &= \frac{\text{OD}}{\text{OE}} = \frac{\text{GB}}{\text{GC}} = \frac{\text{OB}_0}{\text{OF}} = \cos \alpha,\end{aligned}$$

from the property of an ellipse;

$$\text{hence } \tan \phi = \cos \alpha \tan \theta$$

and, therefore, differentiating—

$$\begin{aligned}\sec^2 \phi \cdot \delta \phi &= \cos \alpha \cdot \sec^2 \theta \cdot \delta \theta \\ \text{or } \frac{\delta \phi}{\delta \theta} &= \cos \alpha \cdot \frac{\sec^2 \theta}{\sec^2 \phi} = \frac{\tan \phi}{\tan \theta} \cdot \frac{\sec^2 \theta}{\sec^2 \phi} = \frac{\sin 2\phi}{\sin 2\theta}\end{aligned}$$

This ratio may be obtained graphically (the proof of the construction may be left to the reader) by describing a circle on  $OA_1$  as diameter to intersect the lines  $OB$ ,  $OC$  in  $K$  and  $L$  respectively; the angular-velocity ratio of the second and first shafts is then  $\frac{OS}{OT}$ , where  $LS$  and  $KT$  are drawn perpendicular to  $OB_0$ . Or, if the angular velocity of the first shaft be constant and represented by  $OA_0$ , the angular velocity of the second shaft when the first arm occupies the position  $OA$  will be represented by  $OV$ , where  $SV$  is drawn parallel to  $TA_0$ . Also, for a given angle,  $\theta$ , turned through by the first shaft, the angular-velocity ratio may be readily shown to be given by—

$$\frac{\delta \phi}{\delta \theta} = \frac{\cos \alpha}{1 - \sin^2 \alpha \sin^2 \theta}$$

and thus the angular-velocity ratio varies from  $\cos \alpha$  to  $\frac{1}{\cos \alpha}$  each quarter of a revolution.

By marking off the distance  $OZ$ , equal to  $OV$ , along  $OA$ , and repeating the construction for a number of positions of the mechanism, a polar curve of angular velocity for the second shaft may be drawn. For a quarter of a revolution, it is shown by the

chain-dot line, the corresponding curve for the first shaft being the quadrant  $A_0AF$ .

§ 136. **Universal Coupling. Double Hooke's Joint.**—In practice the joint is made as compact as possible, the cross being sometimes replaced by a circular ring or disc having four joints projecting

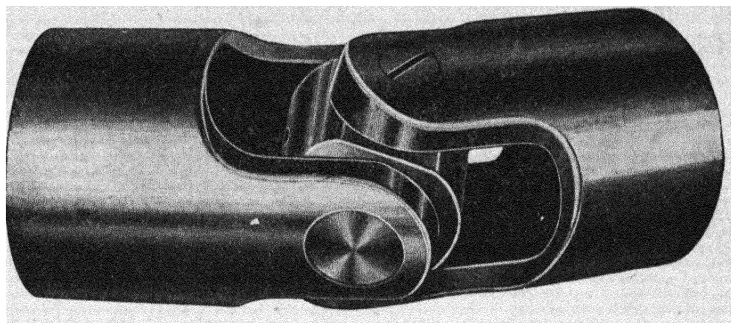

FIG. 216.

from its circumference (Fig. 216). It is then frequently termed a *universal joint*. When used as a coupling for power purposes, the variation in velocity ratio gives rise to vibratory and unsteady motion; and to obviate this, a *Double Hooke's joint*, or double universal coupling, may be used. The two shafts  $P_1$  and  $P_2$  are not coupled directly together, but through a connecting link, C

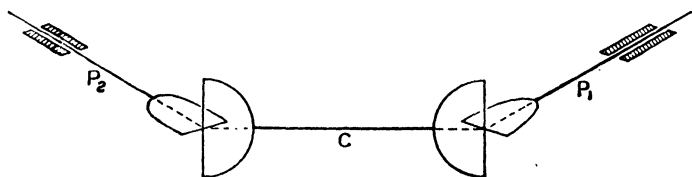

FIG. 217.

(Fig. 217), the connecting link forming a Hooke's joint with each shaft. It is clear that, provided the connecting link is equally inclined to the two shafts and its own forks lie in the same plane, the angular-velocity ratio of the two shafts  $P_1$  and  $P_2$  will be constant and equal to unity at every instant.<sup>1</sup> The three axes will, of course, lie in the same plane, and the planes of the forks

<sup>1</sup> This motion may be transmitted through non-intersecting shafts.

on the two shafts,  $P_1$  and  $P_2$ , will, at every instant, make equal angles with that plane. Moreover, in addition to the position shown in Fig. 217, the second shaft may be parallel to the first without affecting the accuracy of the motion; nor will the accuracy depend in any way upon the magnitude of the inclination of the link and the two shafts.

§ 137. **Application to Testing-machines.**—Hooke's joint is used for a variety of purposes. As a flexible coupling, it can be used

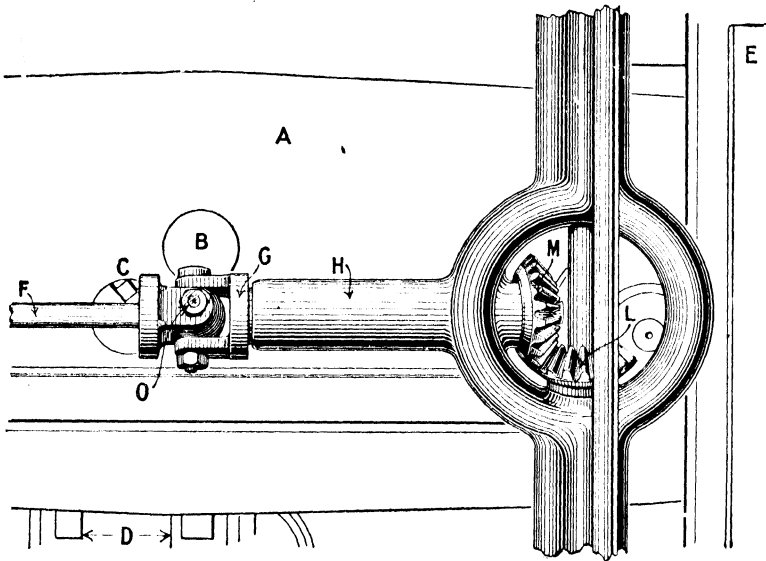

FIG. 218.

to connect two shafts when the direction of one or other of the axes is subject to slight variations. It is almost invariably used in machines designed for testing the strength of materials. In such machines a beam, oscillating about a fixed knife-edge, carries a second knife-edge, from which hangs a shackle, to which one end of the specimen is clamped. The lower end of the specimen is clamped to a second shackle, which is attached to the ram of a hydraulic cylinder. On applying pressure, the pull is transmitted through the specimen, and the beam is tilted up. This tilting is prevented

by a travelling weight, which is carried by the beam, and which can be placed in any position on the beam; so that the beam can be kept floating between two stops for all loads on the specimen. The position of the travelling weight on the beam will clearly be a measure of the pull. The travelling weight can be run along the beam by means of a screw—turning in bearings carried by the oscillating beam—which meshes with a nut carried by the weight. This screw, which oscillates with the beam, is driven from a spindle which rotates in fixed bearings carried by the frame; and the problem is to transmit the motion from the spindle whose axis is fixed, to the screw whose axis oscillates, without in any way constraining the free oscillatory motion of the beam. Any such constraint would introduce unknown reactions, and the precise pull on the specimen could not therefore be determined. In order to effect the desired purpose, a Hooke's joint is almost invariably used.

The beam, in Fig. 218, is represented by A, and oscillates about the fixed knife-edge B. The second knife-edge, which is carried by the beam, is denoted by C; and from this is suspended the shackle D. The pull on the specimen tends to tilt A about B; and this tilting tendency is met by the jockey weight E, which, as already explained, can be moved along the beam by means of a screw concealed in the beam. At its extremity the screw carries a spur wheel (not shown), which meshes with a wheel keyed to a spindle, F, which can turn in bearings carried by the beam, and which, therefore, oscillates with the beam. The spindle F is driven from a short spindle, G, which turns in bearings, H, fixed to the frame of the machine, and which carries a bevel wheel, M; whilst M meshes with a bevel wheel, L, keyed to a vertical spindle, turning in fixed bearings, and which can be rotated by a hand-wheel (not shown). Since the axis of G is fixed, and that of F oscillates through a small angle in a vertical plane, the connection between them must be a flexible coupling, which, as already explained, is generally a Hooke's joint, as shown in Fig. 218. Provided the axis of the fixed knife-edge B, on which the beam oscillates, passes, when produced, through the centre of the rigid cross in the Hooke's joint, the beam (barring

friction) experiences no constraint when it oscillates; but if this condition is not satisfied, the free oscillatory motion of the beam is prevented, and unknown reactions are introduced.

§ 138. **Adjustable Multiple-spindle Drilling Machines.**—Double Hooke's joints are also used in adjustable multi-spindle drilling

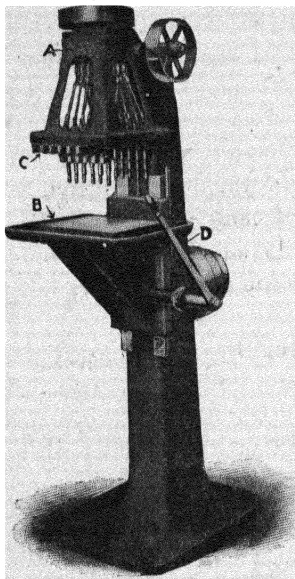

FIG. 219.

machines designed for drilling simultaneously a number of holes in valve flanges, etc. One such machine<sup>1</sup> is illustrated in Fig. 219. The spindles are all driven through universal couplings from a central gear in the drill-head A, and they are adjustable to allow for drilling holes in groups of square, circular, or other form. In setting the spindles, the work is bolted to the table B, the drills are inserted, and the sliding arms C, which carry the drill spindles, are adjusted to bring the spindles into proper alignment. The variation in length of the coupling link between the drill-head and drill, may be provided for by making it in the form of a spindle surrounded by a sleeve, the connection between the two being

by means of a feather key. The spindle-heads are provided with vertical adjustment on the arm to compensate for variation in length of drills. The feed may be brought about either by the rise of the table, or the fall of the drill-head. In Fig. 219, the table is fed up by means of the hand lever D, but larger machines are power fed.

(5) *Double Slider-crank Chain.*

§ 139. **Oldham's Coupling.**—It has been shown that a motion of continuous rotation may be transmitted between two parallel shafts either by the slider-crank chain (pin-and-slot mechanism) or by

<sup>1</sup> By Messrs. Pratt & Whitney

the four-bar chain, but that the angular-velocity ratio varies from moment to moment unless special proportions between the different links are adopted. A motion of continuous rotation may be also transmitted by means of the double slider-crank chain, that is to say, of a chain consisting of two sliding and two turning pairs. In its simplest form, the double slider-crank chain is shown in Fig. 220. The two blocks rotate about fixed centres  $P_1$  and  $P_2$ , and are connected together by a rigid rectangular cross,  $C$ , each arm of which slides over one of the blocks. If the shaft  $P_1$ , and therefore the block, rotate through a small angle, both arms of the rigid cross will rotate through the same angle, and so likewise must the second block and the shaft  $P_2$ . In fact, as motion takes place, the point of intersection of the cross describes a circle having  $P_1P_2$  as diameter, and for any second position of the cross (shown by the dotted lines) the angles turned through by each arm are equal, being in the same segment of a circle; and the centre of the cross,  $C$ , makes two revolutions for each revolution of either shaft. Thus the shafts rotate in the same direction with the same velocity. When used in practice, this coupling is usually known as *Oldham's coupling*; it has already been illustrated and described in § 99.

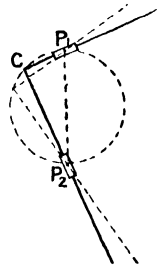

FIG. 220.

§ 140. **Donkey Pump.**—The double slider-crank chain is used for various purposes, some of which have been already referred to. In addition to being used as a coupling, it may be used to mechanically describe an ellipse (§ 82), or to turn up bars of elliptic section (§ 99). In the former case, the link common to the two sliding pairs is fixed; in the latter, and also in Oldham's coupling, the fixed link is the link common to two turning pairs. It is also generally the mechanism adopted in donkey pumps, a sketch of which is shown in Fig. 221. The steam cylinder is represented by  $S$ , and the pump cylinder by  $P$ —both being bolted to the bed-plate—and the steam-piston and pump plunger work tandem. The length of the stroke is governed by the crank arm, which is keyed to the crank shaft  $C$  at one extremity, and which carries a pin at its other extremity, which is free to turn in a

block, B, capable of sliding in the slot D carried by the piston-rod. In this mechanism, the fixed link is the link common to a sliding

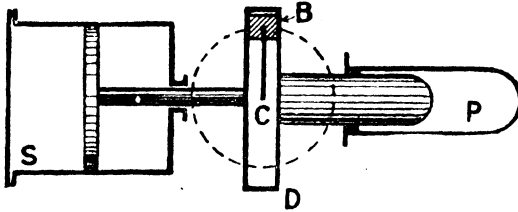

FIG. 221.

and turning pair. If the crank shaft be the driver, the steam cylinder may be replaced by an additional pump.

§ 141. **Worthington's Direct-acting Pump.**—A sketch of Worthington's direct-acting pump is shown in Fig. 222, in which S represents the steam cylinder, and P the pump cylinder—the piston and plunger working tandem on the same rod. The resistance

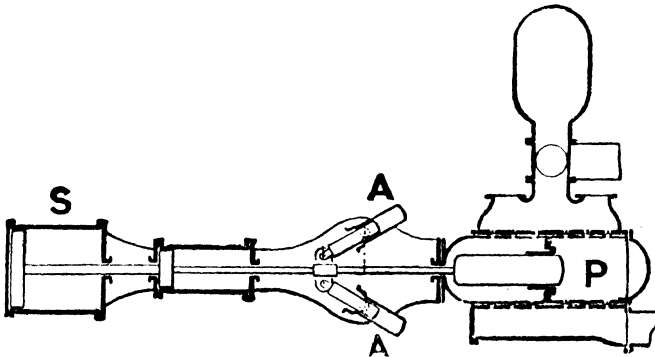

FIG. 222.

encountered by the plunger is usually sensibly constant, but the driving force on the steam-piston is greatest during the first half of the stroke, and falls off, due to expansive working of the steam, during the latter part of the stroke. To equalize matters, and to make the pump work steadily, compensating cylinders, A, A, are used. As shown in the sketch, the compensating cylinders oscillate on trunnions, and the piston-rods are attached to the

common rod of the main piston and plunger. In the first part of the stroke these pistons are pushed into the oscillating cylinders, and the air behind them is compressed in a closed chamber. The work done on the steam-piston is therefore not entirely spent on the plunger, but in compressing the air; and during the latter part of the stroke the pistons move out of the oscillating cylinders, and the work previously spent in compressing the air is given out as the air expands, with the result that more work is expended on the plunger than is exerted on the steam-piston. The oscillating cylinders, in point of fact, serve the part of fly-wheels, alternately storing and restoring energy. The stroke of the piston and plunger is governed by tappets.

§ 142. **Rapson's Slide.**—In Rapson's slide, the arrangement usually adopted is shown in Fig. 223. The end of the tiller A is

made rectangular in section, and perfectly true and parallel at its outer end. A carriage or frame, B (shown enlarged in Fig. 224), fitted with a swivelling block, C, runs on guide rails (which replace

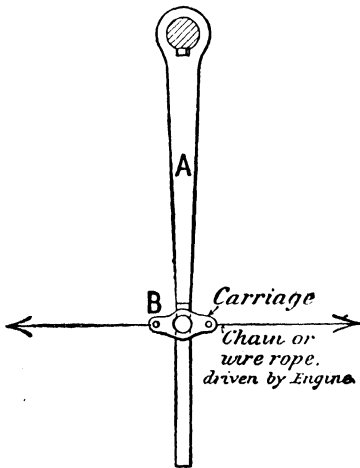

FIG. 223.

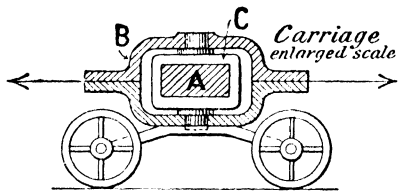

FIG. 224.

a slide) carried from side to side of the ship, at right angles to the longitudinal centre line. This swivelling block fits over the rectangular end of the tiller. The frame or carriage is worked to the right or left by chains or wire ropes from the steering engine. As the rudder is turned, the block swivels in the carriage and the tiller slides in the block. If the turning moment on the

steering engine remains constant, the pull in the chains remains constant, and the turning moment therefore remains constant as the rudder is put over. In the gear described in § 116, the turning moment on the rudder-head gets less as the helm is put over, because the effective leverage of the links FG and KH obviously gets less. In many gears the arrangement is such that the turning moment actually increases as the rudder is put over (§§ 152, 201, and 220).

## CHAPTER V.

### VELOCITY-RATIO DIAGRAMS—APPROXIMATE SOLUTIONS TO LINK MOTIONS.

§ 143. FOR simple mechanisms, such as those discussed in the last chapter, the velocity ratio of any two points is, perhaps, best determined by using the method of instantaneous centres as there described. But for more complicated link-work mechanisms the most straightforward, and in many other respects the best, method is to draw what is termed the velocity-ratio diagram for any given configuration of the mechanism. We now proceed to consider this second method of determining the velocity ratio of any two points in the mechanism relative to one of the links. The application of this method to mechanisms was first fully discussed in an admirable paper by Prof. R. H. Smith, published in the *Proceedings of the Royal Society of Edinburgh*, January, 1885.

§ 144. **Vectors.**—If a point in a body have a certain motion impressed upon it, that motion may be represented in magnitude and direction by a straight line—the line being drawn in the direction of motion, and its length being made proportional, on some scale, to the velocity at the instant considered. Such a line is usually termed a *vector*. If the point have simultaneously impressed upon it two motions, each of those motions may be represented in magnitude and direction by a straight line, and the resultant motion of the point is represented in magnitude and direction by the diagonal of the parallelogram of which the two lines representing the component velocities are sides. Thus, if a point, P (Fig. 225), have impressed upon it two motions which can be

represented by PA, PB respectively, the resultant motion is represented in a magnitude and direction by PC.

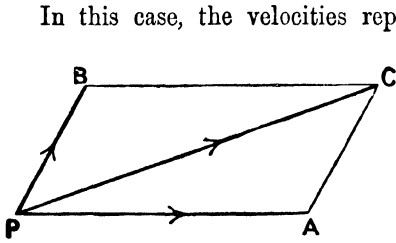

FIG. 225.

In this case, the velocities represented by PA and PB are referred to some body, which might either be the earth, the deck of a ship, or the base plate of a machine. But whatever the body of reference is, or whether it is moving relatively to the earth or not, the resultant

velocity, represented by PC, is referred to the same body.

Next, suppose there are two independent points, A and B, moving in the directions shown with given velocities over a base plate, P (Fig. 226). The point B has a certain motion relative to

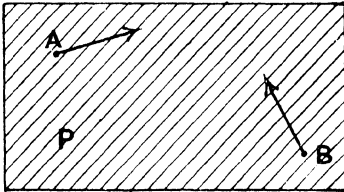

FIG. 226.

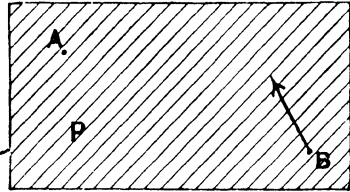

FIG. 227.

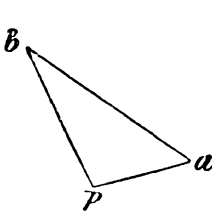

FIG. 228.

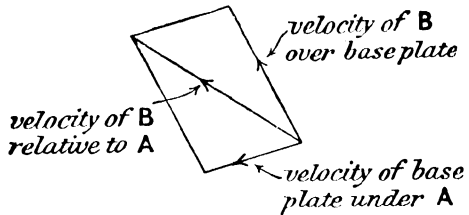

FIG. 229.

the moving point A—that is to say, to a person attached to and moving with A, B will appear to be moving with a certain velocity and in a certain direction. To find that relative velocity in magnitude and direction, bring A to rest by impressing upon

everything a velocity equal and opposite to that of A. The state of affairs will then be as represented in Fig. 227, in which B has two motions impressed upon it, namely, the motion of B *over* the base plate, and the motion of the base plate itself, which will be in the direction of the arrow, and which will be equal in magnitude to the original velocity of A. The resultant velocity of B will now be its velocity relative to A, since A has, by this device, been brought to rest, and its magnitude and direction is determined by drawing the parallelogram of velocities, shown in Fig. 228. This result may be more conveniently represented by referring to Fig. 226, and drawing two lines (Fig. 229),  $pa$ ,  $pb$ , to represent the velocities of A and B, in magnitude and direction, over the base plate. The joining line  $ab$  will then (by comparison with Fig. 228) represent the velocity of B relative to A, the direction being from  $a$  to  $b$ .

It will be noticed that with this notation it is unnecessary to put arrows on the vector lines to represent the direction of motion. In all cases, the first letter of the vector represents the body of reference. Thus the vector  $pa$  means that the motion is from  $p$  to  $a$  and represents the velocity of A relative to P; the vector  $ap$  would represent the velocity of P relative to A, and would be in the direction from  $a$  to  $p$ . In the same manner,  $ab$  is the velocity of B relative to A, and is in the direction from  $a$  to  $b$ ; whilst  $ba$  would represent the velocity of A relative to B, and would be in the direction from B to A.

§ 145. Illustrations.—To familiarize ourselves with this notation, let us take one or two simple cases. Take, first, falling rain as seen by a person seated in a moving train. Let E, T, and R refer to the earth, train, and rain, and suppose that the velocities of the train and rain relative to the earth are known. Let these velocities be represented by the vectors  $et$ ,  $er$  (Fig. 230). Then the velocity of the rain relative to the train is (remembering that  $t$  is the first letter) represented in magnitude and direction by  $tr$ . In other words, relative to a person seated in the train, the rain appears to be descending in the direction  $tr$ , the direction of motion being from  $t$  to  $r$ .

Again, as a second illustration, take the case of the smoke

from the funnel which blows over the deck of a ship. If the speed and course of the ship, and also the velocity and direction with which the smoke blows over the deck are known, the velocity and direction of the wind on shore can be at once determined. Let  $E$ ,  $S$ ,  $W$  refer to the earth, ship, and wind, and take the ship as our body of reference. If the ship be moving due north, the earth relatively to the ship is moving due south. Draw, therefore (Fig. 231),  $se$  to represent the velocity of the earth relatively to the ship, and  $sw$  to represent the velocity of the smoke over the ship's deck. Then the velocity of the



FIG. 230.

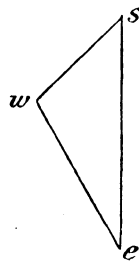

FIG. 231.

wind relative to the earth is  $ew$ , in the direction from  $e$  to  $w$ .

§ 146. **Application to Mechanisms.**—In applying this method to mechanisms, the fixed link or base plate is represented by  $P$ , as before (Fig. 232), and the points  $A$  and  $B$  represent two points either in the same or different moving links. The motions of the points  $A$  and  $B$  are, however, no longer independent. If the points  $A$  and  $B$  are points in the same link, it at once follows that the distance between them is always the same; consequently, the motion of  $B$  relative to  $A$  *must* be perpendicular to  $AB$ , since, if it were not, the points  $A$  and  $B$  would either be separating from, or approaching to, each other. To express it differently, whatever be the precise motions of  $A$  and  $B$  over the base plate, the components of their velocities in the direction joining them must be the same. The velocity diagram must consequently be as shown in Fig. 233, in which  $pa$  is parallel to the direction of the motion of  $A$ ,  $pb$  to the direction of motion of  $B$ , and  $ab$  is drawn perpendicularly to  $AB$ . If, therefore, the direction of motion of  $A$  and  $B$  are known and the velocity of one of them be given, the velocity of the other can be at once determined. Moreover, the velocity of

B relative to A is  $ab$ , and acts from  $a$  to  $b$ ; and this represents the velocity with which the point B is moving about the (moving) centre A. The angular velocity of AB is consequently  $\frac{(ab)}{AB}$ , the numerator representing velocity in so many feet per second, and the denominator length in so many feet. This ratio represents the rate of increase,  $(\frac{d\theta}{dt})$ , of the angle  $\theta$  which the line AB makes with any line fixed to the base plate. The motion of the point B over the base plate may be looked upon as compounded of two motions, namely, the motion of A over the base plate, represented by  $pa$ , and the motion of B about the point A, represented by  $ab$ ; the resultant  $pb$  is the motion of B over the base plate.

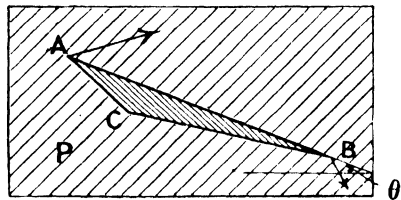

FIG. 232.

If a third point, C, is rigidly attached to AB, in order to obtain the velocity of C in magnitude and direction, it will be noticed that C relative to A moves perpendicularly to AC, and relative to B perpendicularly to BC.

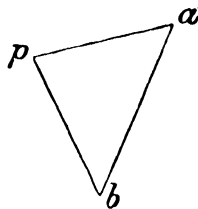

FIG. 233.

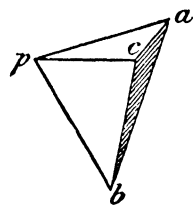

FIG. 234.

Hence, through  $a$  (Fig. 234) draw a line  $ac$  perpendicular to  $AC$ , and through  $B$  a line  $bc$  perpendicular to  $BC$ . These intersect at the point  $c$ , and  $pc$  represents the velocity of C in magnitude and direction over the base plate. Since the sides of the triangle  $abc$  are respectively perpendicular to the sides of the triangle  $ABC$ , these two triangles are similar, and consequently the ratios  $\frac{(ab)}{AB}$ ,  $\frac{(ac)}{AC}$ ,  $\frac{(cb)}{CB}$  are all equal. In fact, each of these ratios represents the same thing, namely, the rate at which the angle which any of the sides makes with a fixed line is increasing. As before, the velocity of C is made up of two components, namely, the velocity of A over the base plate

represented by  $pa$ , and the velocity of C about A represented by  $ac$ .

If the point C lie in the line AB, so likewise will the point  $c$  lie in the line  $ab$ , and  $c$  will divide  $ab$  in the same proportion that C divides AB.

Let us proceed to apply this method to a few actual mechanisms.

§ 147. **Four-bar Chain.**—Let  $P_1, P_2$  be the fixed centres of rotation, and AB the coupler (Fig. 235). Then, at the instant, A is moving perpendicularly to  $P_1A$ , and B to  $P_2B$ . Draw a line,  $pa$  (Fig. 236), perpendicular to  $P_1A$ , to represent the velocity of A on some convenient scale; draw also  $pb$  perpendicular to  $P_2B$ , and  $ab$  perpendicular to AB to intersect in  $b$ . Then on the same scale that  $pa$  represents the velocity of A,  $pb$  will represent the velocity

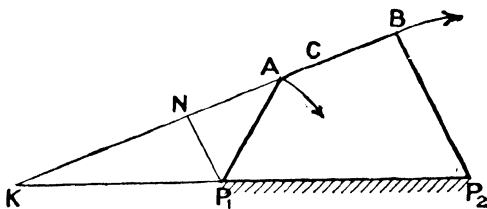

FIG. 235.

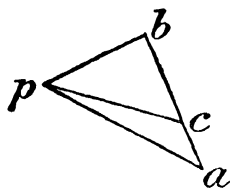

FIG. 236.

of B, and  $ab$  will represent the velocity of B about A. If  $P_1N$  be drawn parallel to  $P_2B$  to meet BA in N, the triangles  $pab$  and  $P_1AN$  are similar, since corresponding sides are perpendicular to each other. Hence, the velocity ratio of B to A, which is equal to  $\frac{(pb)}{(pa)}$ , is also equal to  $\frac{P_1N}{P_1A}$ , as before (§ 107). Again, the angular velocity of  $P_1A$  is  $\frac{(pa)}{P_1A}$ , and of  $P_2B$ ,  $\frac{(pb)}{P_2B}$ , the numerators representing velocities in, say, feet per second, and the denominators lengths in, say, feet. Hence the angular-velocity ratio of the shaft  $P_2$  to that of  $P_1$  is—

$$\frac{(pb)}{P_2B} \cdot \frac{P_1A}{(pa)} = \frac{(pb)}{(pa)} \cdot \frac{P_1A}{P_2B} = \frac{P_1N}{P_1A} \cdot \frac{P_1A}{P_2B} = \frac{P_1N}{P_2B} = \frac{KP_1}{KP_2},$$

where K is the point where the coupler meets the line of centres, as before (§ 107).

If it be desired to find the velocity of any point C in AB, the length  $ab$  must be divided into two segments,  $ac$ ,  $bc$ , such that  $\frac{ac}{ab} = \frac{AC}{AB}$ . The velocity of the point C is then represented in magnitude and direction by  $pc$ .

§ 148. Direct-acting Engine Mechanism.—Here the point A (Fig. 237) moves perpendicularly to PA, and the point B moves parallel to the guides. Hence, draw  $pa$  (Fig. 238) perpendicular to the crank arm to represent the velocity of the crank pin on some scale; draw also  $pb$  parallel to the motion of B, and  $ab$  perpendicular to the connecting-rod AB, to intersect in  $b$ . The velocity of the piston is represented by  $pb$ , and of B about A by  $ab$ . If BA meet the perpendicular through P to the line of stroke in N, the sides

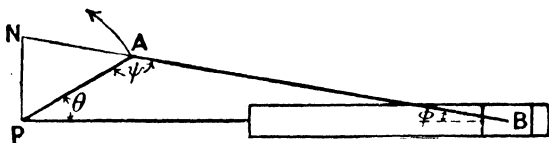

FIG. 237.

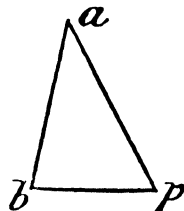

FIG. 238.

of the triangle  $pab$  are perpendicular to those of the triangle PAN, and therefore these two triangles are similar. Hence the velocity ratio of the piston and crank pin, which is equal to  $\frac{(pb)}{(pa)}$ , is also

equal to  $\frac{PN}{PA}$  as before (§ .108). Moreover, if  $\theta$ ,  $\phi$ ,  $\psi$ , have the meanings assigned to them in the figure, the rate of increase of  $\theta$  is  $\frac{(pa)}{PA}$ , and of  $\phi$  is  $\frac{(ab)}{AB}$ . Hence—

$$\frac{d\phi}{d\theta} = \frac{\frac{(ab)}{AB}}{\frac{(pa)}{PA}} = \frac{(ab)}{(pa)} \cdot \frac{PA}{AB} = \frac{AN}{PA} \cdot \frac{PA}{AB} = \frac{AN}{AB};$$

so that if AB represent the rate of increase of  $\theta$ , AN will represent, on the same scale, the rate of increase of  $\phi$ . The rate of

increase of  $\psi$  will be represented by NB (since  $d\psi + d\theta + d\phi = 0$ ), so that, as before—

$$d\theta : d\phi : d\psi = AB : AN : NB$$

Moreover, it must be remembered that these ratios are the same whichever link of the chain is fixed. It can be proved quantitatively by fixing each link in turn, and drawing the corresponding velocity-ratio diagrams; but sufficient has been written on this point in § 108.

§ 149. **Marshall's Valve Gear.**—As a more complicated case, take Marshall's valve gear, which is shown in Fig. 239. The frame of the machine is denoted by P,

the crank shaft being denoted by  $P_1$ . The main piston is represented by B, and the valve by F. C is the centre of an eccentric set at the same angle as the crank arm, and CDE is a link which is coupled to the valve rod at E. The point D forms one extremity of a lever  $P_2D$ , which turns about a centre  $P_2$ . For any position of the gear,  $P_2$  is a fixed centre; but to reverse the engine, the centre

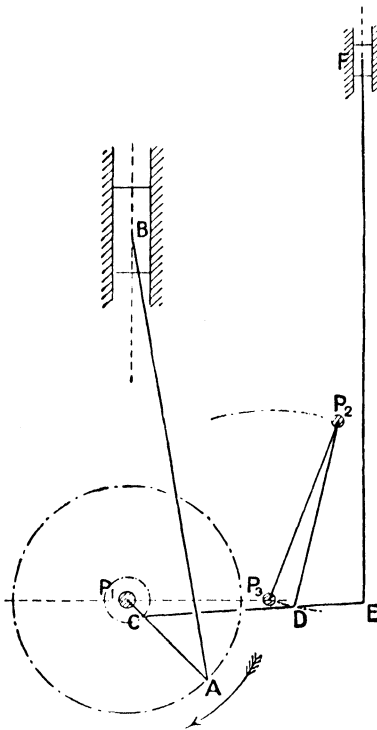

FIG. 239.

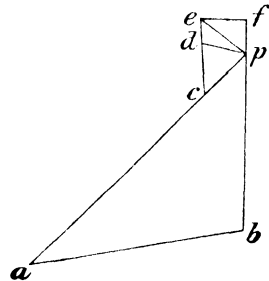

FIG. 240.

$P_2$  is carried at the extremity of a link which can be turned about the centre  $P_3$ ; so that  $P_2$  may occupy any position on the

chain-dotted arc according to the state of the gear. The object is to find the velocity ratio of the valve and piston in the position of the mechanism sketched.

The velocity diagram is shown in Fig. 240. First draw  $pa$  to represent the velocity of the crank pin, and so get the velocity,  $pb$ , of the piston in the manner just described. The velocity of the point C is then represented by  $pc$ , where  $c^1$  is obtained by making  $\frac{pc}{pa} = \frac{P_1C}{P_1A}$ . To find the velocity of D, it will be noticed that D relative to the frame moves perpendicularly to  $P_2D$ , and relative to C moves perpendicularly to CD. Hence, through  $p$  draw a line perpendicular to  $P_2D$  to meet a line through  $c$ , drawn perpendicular to CD, in  $d$ ; the vector  $pd$  represents the velocity of D over the base plate. The velocity of E is obtained by producing  $cd$  to  $e^1$  so that  $\frac{cd}{ce} = \frac{CD}{CE}$ , whence  $pe$  represents the velocity of E. Finally, to find the velocity of F, draw through  $p$  a line parallel to the stroke of the valve (in the present case, taken to be parallel to the stroke of the piston) to meet a line through  $e$  perpendicular to EF in  $f$ . The vector  $pf$  will represent the velocity of the valve on the same scale that  $pb$  represents the velocity of the piston. In the position of the mechanism taken, the piston is moving downwards and the valve upwards.

An approximate solution to this motion will be found in § 157.

§ 150. Joy's Valve Gear.—As a further illustration, take Joy's valve gear shown in Fig. 241. The frame is again denoted by P. The piston is represented by B, the valve by H, and the crank shaft by  $P_1$ . The centre  $P_2$  is fixed, as also, for a given position of the gear, is  $P_3$ ; so that D and F describe circular arcs having  $P_2$  and  $P_3$  as centres respectively. The engine can be reversed by shifting the centre  $P_3$  along the dotted arc which is shown as passing through  $P_3$ .<sup>2</sup> Corresponding to any particular position of the

<sup>1</sup> The positions of the points  $c$  and  $e$  may be found by calculation (using the slide rule), or graphically by drawing proportional triangles. To prevent confusion and unnecessary explanations, the reader is left to develop his own devices.

<sup>2</sup> More frequently the link  $P_3F$  is replaced by a circular guide having  $P_3$  as centre of curvature, in which a block carrying the pin F slides. Reversal is effected by swinging this guide over about pins carried by bearings in the frame.



to C, D is moving perpendicularly to CD. Draw, therefore, the lines  $pd$ ,  $cd$  perpendicular to  $P_2D$  and CD respectively to intersect in  $d$ ;  $pd$  represents the velocity of D. The velocity of E, represented by  $pe$ , is then obtained by making  $\frac{de}{dc} = \frac{DE}{DC}$ . The velocity of F is similarly obtained by drawing lines  $pf$  and  $ef$  perpendicular to  $P_3F$  and EF respectively to intersect in  $f$ , giving  $pf$  as the velocity of F. The velocity of G, represented by  $pg$ , is then obtained by producing  $ef$  to  $g$ , so that  $\frac{ef}{eg} = \frac{EF}{EG}$ . Finally, the velocity of the valve H is obtained by drawing  $gh$  perpendicular to GH to meet a line drawn through  $p$  parallel to the direction of motion of the valve (in this case, taken to be parallel to the direction of motion of the piston) in  $h$ . The length  $ph$  represents the velocity of the valve on the same scale that  $pb$  represents the velocity of the piston. In the position shown, the direction of motion of the valve is clearly opposite to that of the piston.

It will thus be seen that the velocity diagrams, shown in Figs. 240, 242, are such that the lines radiating from  $p$  represent the velocities of the different points in the mechanisms, over the base plate, on any convenient scale.

In the above it has been assumed that the points A, B, C lie on one straight line. If the pin C lie on one side of the line joining AB, the necessary modifications in the velocity diagram are easily traced. The point  $e$  will not lie on the line joining  $ab$ , but will be on one side of it, and (§ 146) the triangle  $acb$  in the velocity diagram will be similar to the triangle ACB in the mechanism diagram, corresponding sides being perpendicular to each other; and, similarly, if the pins C, E, D or E, F, G are not collinear. This may be left to the reader to develop.

An approximate solution to this motion will be found in § 158.

**§ 151. Crank and Slotted-lever Quick-return Motion.**—In § 121 the velocity ratio of the ram to the crank pin was obtained by first finding the angular velocity of the variably rotating crank. It may be obtained otherwise by drawing the velocity diagram for any position of the mechanism. Thus denote (compare Fig. 193) the fixed centres by  $P_1$  and  $P_2$  (Fig. 243), and draw  $pc$  (Fig. 244)

perpendicular to  $P_1C$ , to represent the velocity of  $C$ . Let the point in the lever  $P_2Q$  immediately under the pin  $C$  be denoted by  $C'$ . Clearly the point  $C'$  is moving perpendicularly to  $P_2Q$ , and the relative motion of  $C'$  and  $C$  is in the direction of the lever, since the block slides along the lever. Draw therefore  $pc'$  perpendicular to  $P_2Q$  to meet a line through  $c$  drawn parallel to  $P_2Q$  in  $c'$ ; then  $cc'$  is the velocity with which the block is sliding

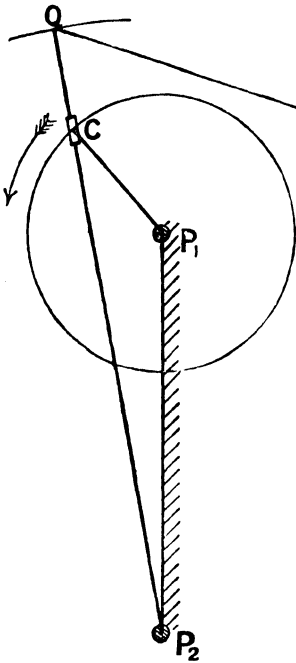

FIG. 243.

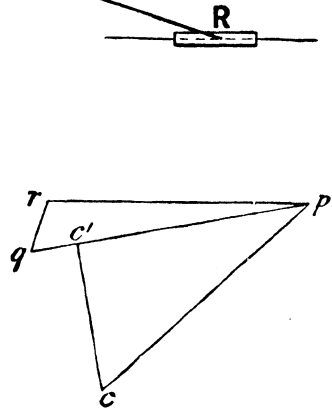

FIG. 244.

over the lever, and  $pc'$  is the velocity of the point  $C'$ , so that  $\frac{pc'}{P_2C}$  is the angular velocity of the lever. To get the velocity of  $Q$ , represented by  $pq$ , produce  $pc'$  to  $q$ , and make  $\frac{pq}{pc'} = \frac{P_2Q}{P_2C}$ . The velocity of the ram  $R$  is represented by  $pr$  where  $qr$  is drawn perpendicular to  $QR$ , and  $pr$  is drawn parallel to the line of stroke of the ram.

§ 152. *Ollis' Steering Gear*.—Two steering gears for actuating the rudder-head of a ship have been already noticed, namely, the gear described in § 116, in which the turning moment on the rudder-head gets less as the helm is put over, and that described in § 142, in which the turning moment on the rudder-head is constant for all positions. Now, as the rudder is put over, the force necessary to move it increases; hence many gears have been designed in which the object is to make the turning moment on the rudder-head increase as the helm angle increases. This can be effected provided the angular-velocity ratio between the rudder-head and crank shaft gets less as the helm is put. One gear which satisfies this condition is *Ollis' gear*; others are noticed in §§ 201, 220.

A diagrammatic sketch of *Ollis' gear* is shown in Fig. 245,

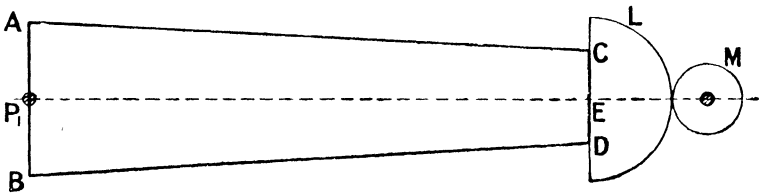

FIG. 245.

which represents the mechanism in the mean position. The link AB is keyed to the rudder-head P<sub>L</sub>, and equal coupling-rods, AC, BD, are attached at one end to A and B respectively, and to pins C and D at the other end. The pins C and D are attached to a circular spur wheel, L, whose centre is E; and this spur wheel is driven from the steering-engine shaft through the pinion M. If the link BD be dispensed with, and only one coupling-rod used, the centre E may be fixed; and, in any position of the mechanism, the angular-velocity ratio between the spur wheel L and the rudder-head is (§ 107)  $\frac{KP_1}{KE}$ , where K (not shown) is the point of intersection of the coupling-rod and the line of centres produced. But if the coupling-rod BD is added, there is an additional constraint, and the centre E of the wheel L can no longer be fixed. In *Ollis' gear* a pin or stud at E is virtually carried by a block which can slide in a longitudinal slot, as shown in Fig. 246

(compare § 116, in which the screw shaft has an axial shift). In that case, E suffers a displacement as the helm is put over, and for any displaced position of the rudder, the mechanism may be plotted in the following manner. With A and B as centres (Fig. 246) and radii equal to the lengths of the coupling-rods describe circular arcs (not shown). Then, on the edge of a piece of paper, mark off distances apart equal to C, E, and D; and, keeping the central mark on the line of stroke of E, move the paper until the

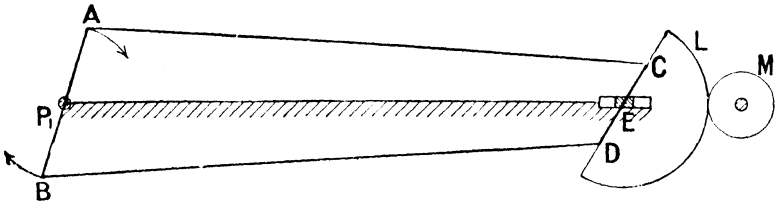

FIG. 246.

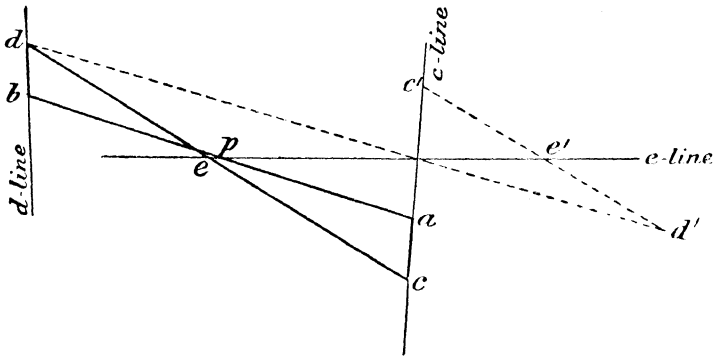

FIG. 247.

end points lie on the two circular arcs. This will correspond to the new position of CED, and it will be found that the displacement of the pin E is so slight as to be hardly appreciable. In fact, so slight is the displacement that it is generally sufficiently accurate to assume it fixed in getting the angular-velocity ratio between L and P<sub>1</sub>. The approximate angular velocity ratio between L and P<sub>1</sub> may be taken to be the mean of the angular velocity ratios as given by the four bar chains P<sub>1</sub>ACE and P<sub>1</sub>BDE. But the *true* velocity ratio, in any displaced position, may be found as follows.

Taking any point,  $p$  (Fig. 247), draw lines  $pa$ ,  $pb$  to represent the velocities of A and B respectively; these will be equal and opposite, and will be perpendicular to AB. Since C moves relatively to A in a direction perpendicular to AC, the point  $c$  must lie on a line through  $a$  perpendicular to AC; and similarly, the point  $d$  must lie on a line through  $b$  perpendicular to BD. Draw these lines, and call them respectively the  $c$  and  $d$  lines. The point  $e$  must also lie on a line through  $p$  parallel to the stroke of E; call this the  $e$  line. We thus get three lines on which the points  $c$ ,  $e$ ,  $d$  must lie, but, in addition, the line  $ced$  in the velocity diagram must be perpendicular to the line CED in the mechanism diagram (since D relative to C moves perpendicular to CD); and also  $ce$  must equal  $ed$  (since CE is equal to ED). To satisfy these conditions, draw *any* line perpendicular to CD to meet the  $c$  and  $e$  lines in  $c'$  and  $e'$  respectively, and produce  $c'e'$  to  $d'$  such that  $e'd'$  is equal to  $c'e'$ . Join  $d'$  to the point of intersection of the  $c$  and  $e$  lines, and let the line so obtained intersect the  $d$  line in  $d$ . Through  $d$  draw a line parallel to  $c'e'd'$  to meet the  $e$  and  $c$  lines in  $e$  and  $c$  respectively; the line  $ced$  is the required line, because it satisfies all requirements. The velocity of the sliding block is  $pe$ , and is small; the velocity of C about E is  $ec$ , and the angular velocity of the wheel L is  $\frac{ec}{EC}$ .

The angular velocity of the rudder-head to the wheel L gets less the greater the helm angle; and usually the velocity ratio in the extreme position (when the helm angle is  $35^\circ$  about) is one-half to one-third the velocity ratio in the mean position.

§ 153. Stephenson's Link Motion.—A diagrammatic sketch of this mechanism is shown in Fig. 248. The crank shaft is  $P_1$ , the eccentric radii  $P_1A$  and  $P_1B$ , and the extremity of the valve rod is F. The valve rod is attached by a pin to a block which can slide over the link CD, the ends C and D of the link being at the extremities of the eccentric rods AC and BD. To close the chain, a point, E, in the link CD is constrained to move in a circular arc having  $P_2$  as centre. The link CD is usually curved but, for simplicity, it has been taken straight; and, moreover, the pin E has been taken to lie in the centre line of the link, whereas it may

lie on one side. For any state of the gear,  $P_2$  is a fixed centre; but in order to alter the state of the gear, and to reverse the engine,  $P_2$  is carried at the extremity of a bell-cranked lever with turns about  $P_3$ . When the link  $P_3P_2$  is shifted over, the link CD slides in the block at F, and thus either of the pins C and D may be brought near to the valve rod.

To plot the mechanism for a particular state of the gear (that is, for a particular position of  $P_2$ ) and for a given position of the eccentrics, proceed as in the previous case. Describe circular arcs (not shown) with A and B as centres, and radii equal to the length of either eccentric rod (AC or BD); and with  $P_2$  as centre draw a circular arc with radius  $P_2E$ . Mark off along the edge of a piece of paper three collinear points at distances apart equal to CE, ED, and move the paper about until the marks lie on the three circular arcs.

The object is to determine the velocity of the valve, and also the sliding velocity of the block over the link CD, when the velocities of the centres A and B are known.

Draw  $pa$ ,  $pb$  (Fig. 249) perpendicular to  $P_1A$ ,  $P_1B$  to represent on some scale the velocities of the eccentric centres A and B. The lengths of these lines will be proportional to the lengths of  $P_1A$  and  $P_1B$  respectively, and the joining line  $ab$  will be perpendicular to the joining line AB. Since C relative to A moves perpendicularly to AC, the point  $c$  must lie on the line through  $a$  perpendicular to AC. Call this the  $c$  line. Similarly, the point  $d$  will lie on a line through  $b$  perpendicular to BD, and the point E (since E moves perpendicular to  $P_2E$  relative to the frame) on a line through  $p$  perpendicular to  $P_2E$ . Call these the  $d$  and  $e$  lines. We thus get the lines on which the points  $c$ ,  $e$ ,  $d$  must lie. But since the points C, E, D lie on one line in the mechanism diagram, the points  $c$ ,  $e$ ,  $d$  must also lie on one line in the velocity diagram, and the line  $ced$  in the velocity diagram must be perpendicular to the line CED in the mechanism diagram; and, moreover, the ratio  $\frac{ce}{cd}$  must equal  $\frac{CE}{CD}$ . To satisfy these conditions, take any convenient point  $d'$  on the  $d$  line, and draw a line perpendicular to DE to meet the  $e$  line in  $e'$ . Produce it to  $c'$  such that  $\frac{d'e'}{d'c} = \frac{DE}{DC}$ .



parallel to the link,<sup>1</sup> whilst the actual velocity of F relative to the base plate is vertical. Draw, therefore, a vertical line through  $p$  to meet a line through  $f'$  parallel to the link CD in  $f$ . Then  $pf$  is the velocity of the valve, and  $ff'$  is the sliding velocity of the link in the block. In the position of the mechanism shown the valve is moving upwards, and the link is sliding from left to right in the block.

If the link CD be curved, or the point E be on one side of the centre line, the best thing to do is to make a template of the slotted link. The  $c$ ,  $e$ , and  $d$  lines must be obtained exactly as before, but instead of having the straight line  $d'e'e'$ , it must be replaced by the template, care being taken that the position of the template in the velocity diagram is perpendicular to its position in the mechanism diagram. The rest of the work is exactly the same as before, the line  $f'f$  being drawn parallel to the tangent to the curved link at the point F. This may be left to the reader to develop.

An approximate solution to this motion will be found in the next article.

§ 154. **Approximate Solution of Stephenson's Link Motion.**—The work involved in finding the displacement and velocity of the valve in Stephenson's link motion is considerable, even for one position of the gear, and for a number of positions becomes prohibitive. It is desirable, therefore, to obtain some solution which, although only approximate, is sufficiently accurate for ordinary purposes. This is all the more important when it is remembered that the principal part of the analysis of the Stephenson link motion is to find the relative displacements of the valve and piston, rather than the exact value of the velocity ratio. To thoroughly understand the approximate solution, the simplest way is, perhaps, to proceed as follows.

*First Step in the Solution.*—Let the valve rod of an engine be actuated by the mechanism  $P_1ACFDBP_2$ , sketched in Fig. 250, in which  $P_1$ ,  $P_2$  are parallel shafts rotating at the same speed;  $P_1A$ ,

<sup>1</sup> This is only true of the points F and F'. The velocity of any other point, such as E, in the link relative to F consists of this sliding motion, together with a swinging motion about F. The point F', immediately opposite to F, does not possess this swinging motion.

$P_2B$ , two crank arms keyed to the crank shafts;  $AC, BD$ , two connecting-rods;  $CD$ , a connecting-link; and  $F$ , the point in  $CD$  to which the valve rod is attached by means of a pin joint, so that the point  $F$  in the link  $CD$  is constrained to describe a vertical straight line. For any position of the two cranks, the mechanism is plotted by using a template, as already explained in §§ 152, 153. To correctly determine the velocity of the valve, the velocity diagram must be drawn as in the previous case. It is shown in Fig. 251, the line  $efd$  being obtained from the construction line  $cf'd'$ .

When this mechanism is actually applied to actuate a valve, the rods  $CA, DB$  are very long compared to the crank radii  $P_1A, P_2B$ , and the mean position of the link  $CD$  is perpendicular to the direction of motion of the valve; and, moreover, in all positions the inclination of the link  $CD$  to the horizontal would usually be very small. Consequently, as an approximate solution, the obliquities of the connecting-rods may be neglected, and the extremities  $C$  and  $D$  assumed to move in sensibly vertical lines passing through the centres  $P_1, P_2$ . The points  $C$  and  $D$  would thus move in a simple harmonic manner, and so, likewise, would every point in the link  $CD$ . The modified velocity diagram would be as shown in Fig. 252, in which the  $c$  and  $d$  lines would be horizontal, and the line  $efd$  a vertical line through  $p$ . The points  $c$  and  $d$  would thus be obtained directly, and the point  $f$  would be found by subdividing  $cd$  into segments having the ratio  $CF : FD$ . Thus, in Fig. 252, the velocities of the points  $C, F$ , and  $D$  are approximately equal to  $pc, pf$ , and  $pd$  respectively. Now draw a line through  $f$  perpendicular to  $cd$  to meet the line  $ab$  in  $g$ . For a displaced position of the mechanism, the crank arms rotate through equal angles, and the new velocity diagram, represented by the broken lines, will clearly be obtained by turning the triangle  $pagb$  round  $p$  through an angle equal to that turned through by either crank. For in the new diagram, all the lines have the proper direction, and  $f_1$  divides  $c_1d_1$  in the proper ratio, since  $\frac{c_1f_1}{f_1d_1} = \frac{a_1g_1}{g_1b_1} = \frac{ag}{gb} = \frac{f}{fd} = \frac{CF}{FD}$ . Hence, just as the motion of  $C$  is obtained from the crank  $P_1A$  (perpendicular and proportional

to  $pa$ ), and that of D from  $P_2B$  (perpendicular and proportional to  $pb$ ), so the motion of the point F may be assumed to be obtained from a crank arm,  $P_3G$  (Fig. 250), perpendicular to  $pg$  (Fig. 252),

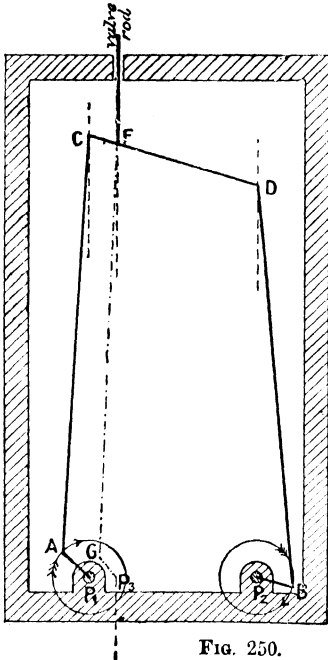

FIG. 250.

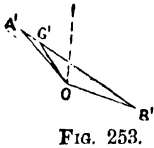

FIG. 253.

rotating about a centre immediately under F; and the length of that crank arm will be given by the relation  $\frac{P_3G}{P_1A} = \frac{pg}{pa}$ . In other words, the mechanism  $P_1ACFDBP_2$  (Fig. 250) may be replaced by the simple mechanism  $FGP_3$ , and, to a very approximate degree, the displacement and velocity of F so obtained will be the same as that obtained by the original mechanism. The length and relative phase of the equivalent crank may therefore be determined by taking any point, O (Fig. 253), and drawing  $OA'$ ,  $OB'$  parallel and proportional to  $P_1A$ ,  $P_2B$  respectively, and then dividing  $A'B'$  at the point  $G'$  so that  $\frac{A'G'}{G'B'} = \frac{CF}{FD}$ ; the line  $OG'$  represents, in length and direction, the equivalent crank; and the centre of rotation of that crank is  $P_3$ . The point F will be at the ends of the stroke when  $P_3G$  is vertical, and its travel will be equal to  $2 \cdot P_3G$ .

*Second Step in the Solution.*—Next, imagine that the two crank arms rotate about the same axis, which, in the first place, is assumed to be in the line of stroke of the valve produced, as in Fig. 254. To find the equivalent crank, find first the crank of centre  $P_1$ , which will give C the same displacement as that given by the actual crank  $PA$ . This may be done by one of the approximate methods given in § 115. Adopting the second of those approximations,

with P as centre and radius equal to AC, draw a circular arc to cut the (approximate) line of stroke of C in H; and draw  $P_1A_1$  in a direction such that the angle  $CP_1A_1$  is equal to  $HPA$ , and of length such that  $P_1A_1$  is equal to  $PA \sec \angle PHP_1$ . Adopt a similar

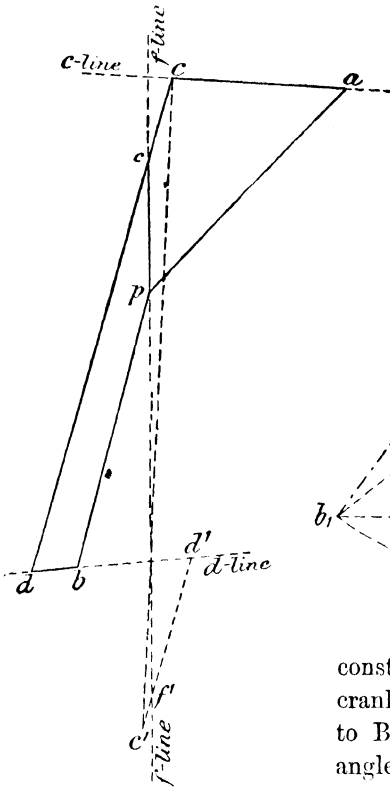

FIG. 251.

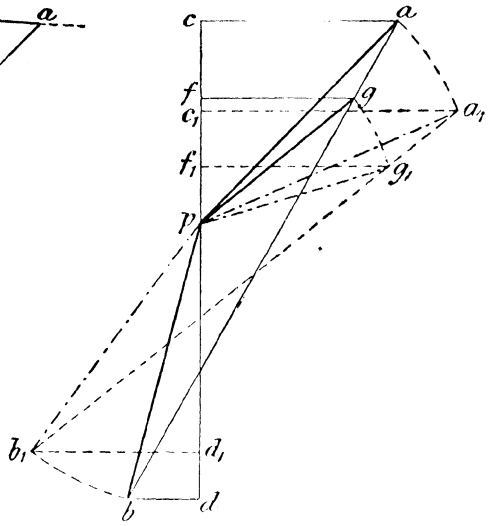

FIG. 252.

construction for the second equivalent crank, namely  $P_2B_2$  (making  $PJ$  equal to  $BD$ , the angle  $JP_2B_2$  equal to the angle  $JPB$ , and  $P_2B_2$  equal to  $PB \sec \angle PJP_2$ ); and having obtained the equivalent cranks for C and D, obtain

that for F by the method just given. These steps may be conveniently performed in the following manner:<sup>1</sup> Make the angle  $FPA'$  equal to  $HPA$ , and the angle  $FPB'$  equal to  $BPJ$ ; from A and B draw perpendiculars to PA, PB respectively, to intersect the lines so drawn in  $A'$  and  $B'$ ; join  $A'B'$ , and divide it

<sup>1</sup> For the sake of clearness and accuracy, an enlarged view of the lower part of Fig. 254 is shown in Fig. 255.

at the point G into segments, such that  $\frac{A'G}{GB'} = \frac{CF}{FD}$ : then PG is the equivalent crank which, actuating F, would give the valve the same displacement and velocity (approximately) as the original mechanism would give it. The valve will be in its extreme positions when the equivalent crank PG is vertical, and the stroke of the valve is 2 . PG.

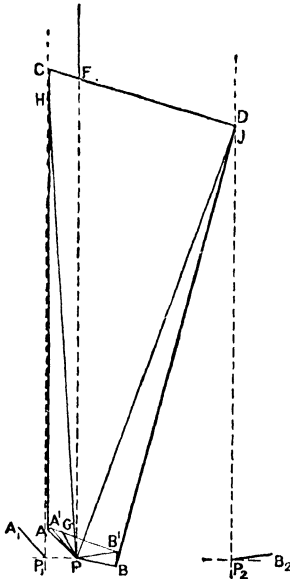

FIG. 254.

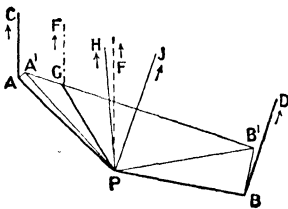

FIG. 255.

If the crank shaft is not in the line of stroke of the valve, the crank obtained in this manner is the equivalent crank turning on an axis in the line of stroke; and to get the equivalent crank at the crank shaft, the method described in § 115 must be reversed.

Again, the link motion represented in Fig. 254 is not quite the same as that represented in Fig. 248. In Stephenson's link motion, the valve rod is not pivoted directly to the link CD, but is pivoted to a block which has a slotting motion along the link; and some point, E (Fig. 248), is constrained to move in a circular arc of radius P<sub>2</sub>E. The horizontal motion of the link, and therefore the departure of the points C and D from the vertical

paths previously assumed, will depend on the position of the centre P<sub>2</sub>; but if the position of that centre, and the length of P<sub>2</sub>E, be such that the mean position of P<sub>2</sub>E is horizontal, and E describes a flat circular arc, the motion of E, and also of C and D, may be assumed vertical, and the slotting effect becomes negligible, so that our previous methods apply.

paths previously assumed, will depend on the position of the centre P<sub>2</sub>; but if the position of that centre, and the length of P<sub>2</sub>E, be such that the mean position of P<sub>2</sub>E is horizontal, and E describes a flat circular arc, the motion of E, and also of C and D, may be assumed vertical, and the slotting effect becomes negligible, so that our previous methods apply.

Finally, the link CD (Fig. 254) is usually curved. In such a case, granting that the conditions just laid down are satisfied, the point F may be taken, not as the actual point of attachment to the block, but as the point in which the line of stroke produced cuts the line joining C and D.

The preceding approximations may be taken to apply to all positions of the gear (that is to say, whether running ahead or astern).<sup>1</sup> For different positions of the gear, C and D move relative to F, and the equivalent eccentric is obtained by dividing A'B' (Fig. 255) in the proper proportion.

§ 155. **Approximate Solution of Radial Valve Gears.**—The method just described may be extended to radial valve gears, such as Hackworth's, Marshall's, Joy's, etc. In all radial valve gears there is always some link corresponding to the link CD in Fig. 250. Two points in such a link receive certain motions, and trace out certain paths; the valve is actuated from a third point in it. The problem is to replace the actual mechanism by some equivalent crank, so that the actual displacement of the valve is very nearly the same as would be given by the equivalent crank.

§ 156. **Hackworth's Valve Gear.**—A diagrammatic sketch of this valve gear is shown in Fig. 256. The piston is represented by B, the crank pin by A, and the crank shaft by P; C is the centre of an eccentric sheave which is set opposite to the crank arm, and CD is a link whose extremity, D, slides on a guide bar or link, ST. The mean position of CD is perpendicular to the stroke, and the valve F is actuated by a rod, FE, worked from some point, E, in it. The guide bar ST can be tilted over, in a counter-clockwise direction, about a centre on the same horizontal line as P, so that it may be made to occupy the dotted or any intermediate position. By this means the travel of the valve may be varied, and the engine reversed. The position of the guide bar, and the direction of motion, refer to the go-ahead state of the gear. As the crank shaft rotates, D moves along the guide bar ST, and E describes a closed oval as sketched. If the guide bar is tilted over to the dotted position, the path of E becomes the dotted oval.

<sup>1</sup> For further information, see Rankine's "Machinery and Millwork," 1st edit., pp. 250-260.



To obtain an approximate solution, it will be noticed that the link CD corresponds to the link CD in Fig. 250. Two points in that link, C and D, receive certain motions, and move along certain paths; the valve is actuated from a third point, E, in it. Our object is, first, to find the equivalent cranks which may be assumed to actuate C and D, and then, from § 154, to find the equivalent crank actuating E. Since F and B (Fig. 256) move in vertical directions, we are principally concerned with the vertical motions of C and D—any horizontal motions of these points producing only secondary effects. The vertical travel of C is obviously  $2 \cdot PC$ , and the vertical travel of D may be found by finding the extreme positions of D on the guide bar, and taking the vertical projection. The extreme positions of D are found by describing circles having centre P, and radii  $CD \pm PC$ , to meet the guide bar; and they practically occur when the crank arm is horizontal. But the vertical travel of D may be found very approximately by remembering that, since the inclination of CD to the horizontal is small for all positions of the mechanism, the horizontal displacement of every point in CD may be taken to be the same.<sup>1</sup> Hence the horizontal displacement of D may be taken to be equal to  $2 \cdot PC$ , since that is the horizontal displacement of C; and the vertical displacement of D will then be equal to  $2 \cdot PC \tan \alpha$ , since the resultant displacement of D is along ST— $\alpha$  being the inclination of the guide bar to the horizontal.

Again, the equivalent cranks actuating C and D will not have the same phase, but will have to be set at a certain angle. To find that angle, it will be noticed that when B is at the top of the stroke, and just about to descend, the point D is about at the middle of its stroke, and is moving downwards. Thus D is about half a stroke ahead of B; or, to express it differently, the equivalent crank actuating D is about  $90^\circ$  *ahead* of the crank PA. Hence, so far as their vertical motions are concerned, the points C, D in the link CD may be imagined actuated by cranks of lengths PC and  $PC \tan \alpha$ , turning about parallel axes; the crank actuating C being  $180^\circ$ , and that actuating D  $90^\circ$ , in advance of the crank arm.

<sup>1</sup> This is equivalent to assuming that the vertical descent of every point in the coupler of Watt's motion is the same (§ 86).

To find the equivalent crank actuating E, the method given in § 154 may be followed. Draw (Fig. 258) P'A', P'C' parallel and proportional to PA and PC respectively, and also P'D' perpendicular to P'A', and of length proportional to PC tan  $\alpha$ ; so that P'C' represents the equivalent crank actuating C, and P'D' that actuating D—the former being 180°, and the latter 90°, ahead of the main crank. Join C'D', and subdivide it at the point E', so that  $\frac{D'E'}{D'C'} = \frac{DE}{DC}$  (Fig. 256): then P'E' represents, in length and phase, the equivalent crank which may be assumed to actuate E.

The construction may be slightly modified as follows: Let OA<sub>1</sub> (Fig. 259) represent the position and length of the main crank arm when the piston is at the top of its stroke, and OC<sub>1</sub> the corresponding position and length of the eccentric radius PC. Draw the line C<sub>1</sub>D<sub>1</sub> inclined at an angle  $\alpha$  with the vertical to meet the horizontal line through O in D<sub>1</sub>; and subdivide OC<sub>1</sub> at  $\epsilon$ , so that  $\frac{OE}{OC_1} = \frac{DE}{DC}$  (Fig. 256). Draw a horizontal line through  $\epsilon$  to meet C<sub>1</sub>D<sub>1</sub> in E<sub>1</sub>: then OD<sub>1</sub> is the equivalent crank for the point D, and OE<sub>1</sub> for the point E. The valve, in other words, may be assumed actuated by a simple eccentric OE<sub>1</sub> instead of the actual mechanism. The travel of the valve is 2 . OE<sub>1</sub>, and it is in its extreme positions when OE<sub>1</sub> is vertical. For different states of the gear, the only thing that alters is  $\alpha$ ; and by drawing lines through C<sub>1</sub> at different inclinations, the effect of tilting the guide bar is at once seen. Thus, if  $\alpha$  be decreased, the equivalent crank will be OE<sub>2</sub>. It will be noticed that in all cases the displacement of the valve from its mean position when the piston is at the end of the stroke is the same; or, to express it differently, the *lap* plus the *lead* of the valve is constant—the travel decreasing, and the angular advance (represented by D<sub>1</sub>OE<sub>1</sub> in the go-ahead position) increasing as  $\alpha$  decreases. In the astern position, the guide bar ST is tilted over in the direction of the dotted line (Fig. 259), and the equivalent crank is OE<sub>3</sub>; so that the valve, instead of opening to steam on the top side of the piston, will open to steam on the bottom side, and the engine will be reversed. In the mid-position of the gear the angle  $\alpha$  is zero, the half travel of the valve being O $\epsilon$ , and its angular advance 90°.

§ 157. **Marshall's Valve Gear.**—In this gear, the eccentric radius  $P_1C$  (Fig. 260) is set at the same angle as the crank radius  $P_1A$ , and the point D, instead of describing a straight line, describes a circular arc having  $P_2$  as centre. Reversal is effected by shifting over the centre  $P_2$ , as already described in § 149. The position of the centre  $P_2$ , and the direction of motion, refer to the go-ahead position. As the crank shaft rotates, the point D moves to and fro along a small circular arc having  $P_2$  as centre, and the point E describes the full-lined oval curve. When the centre  $P_2$  is shifted over to the other extreme position to the left (namely  $P_4$ ), the point E, from which the valve is actuated, describes the dotted-line oval. Moreover, as in Hackworth's gear, the mean position of the link CDE is horizontal, and, for all positions, its obliquity to the horizontal is small; whilst the true velocity ratio of the valve and piston may be found by drawing the velocity diagram, as described in § 149.

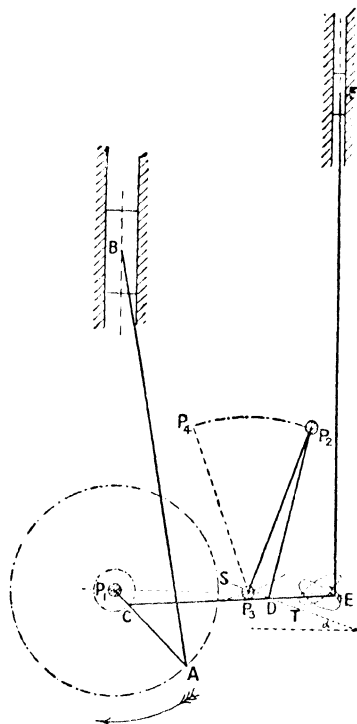

FIG. 260.

To obtain an approximate solution, we may proceed as in the previous case. Since the motions of B and F are vertical, we are chiefly concerned with the vertical motions of C and D, any horizontal motions of these points producing only secondary effects. The vertical travel of C is  $2 \cdot P_1C$ , and the vertical travel of D may be found by finding the extreme positions of D and resolving in a vertical direction. The extreme positions of D are found by describing circular arcs having  $P_1$  as centre and radii equal to  $CD \pm P_1C$ , to intersect the circular arc described by D; but the

vertical travel of D may be approximately obtained as follows. Since the angular motion of  $P_2D$  is usually small, the circular arc described by D may be imagined replaced by a straight line, ST, whose slope is the same as the average slope of the circular arc. Let the inclination of ST to the horizontal be  $\alpha$ . Then, since the obliquity of CDE to the horizontal is always small, the horizontal displacement of every point in it may be taken to be the same; and hence the horizontal displacement of D is the same as that of C, and is therefore  $2P_1C$ . The vertical travel of D is then, as in the previous case,  $2P_1C \tan \alpha$ . In proceeding in this manner, care must be exercised in correctly determining the angle  $\alpha$ .

Again, the equivalent cranks actuating C and D, which are of lengths  $P_1C$  and  $P_1C \tan \alpha$  respectively, have not the same phase, but must be set at a certain angle with each other. To find that angle, when the piston is at the bottom of its stroke and is about to ascend, the point D is about at the middle of its swing and is moving upwards. Thus D is about half a stroke ahead of B; or, to express it differently, the equivalent crank actuating D is about  $90^\circ$  ahead of the crank  $P_1A$ , and therefore also of the eccentric  $P_1C$ . Hence, so far as their vertical motions are concerned, the points C, D in the link CD may be imagined actuated

by cranks of lengths  $P_1C$  and  $P_1C \tan \alpha$  turning about parallel axes, the crank actuating C being set at the same angle as the crank arm, and that actuating D  $90^\circ$  in advance of the crank arm.

The equivalent crank actuating E may then be found as in the previous case. Draw  $OA_1$  (Fig. 261) to represent the crank arm, and  $OC_1$  to represent the eccentric radius when the piston is, say, in its lowest position; draw a line through  $C_1$ , making an angle  $\alpha$  with the vertical, and through O draw a horizontal line to meet it in  $D_1$ . Then (noticing the direction of rotation)  $OC_1$  is the equivalent crank actuating C, and  $OD_1$  that actuating D. Produce  $C_1O$  to  $e$ , so

that  $\frac{C_1O}{C_1e} = \frac{CD}{CE}$  (Fig. 260), and draw a horizontal line through  $e$  to

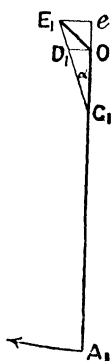

Fig. 261.

meet  $C_1D_1$  produced in  $E_1$ ; then  $OE_1$  is the equivalent eccentric which may be assumed to actuate  $E$ , the half travel of the valve being  $OE_1$ , and its angular advance  $D_1OE_1$ . For different states of the gear, the equivalent eccentric is found by drawing lines through  $C_1$ , making the proper angle with the vertical (as in Hackworth's gear), the angle depending on the position of the centre  $P_2$  (Fig. 260). In the mid-position of the gear,  $a$  is zero, the half travel is  $Oe$ , and the angular advance is  $90^\circ$ .

§ 158. Joy's Valve Gear.—As a final illustration, consider Joy's gear, the true velocity diagram for which is drawn in Fig. 242. In

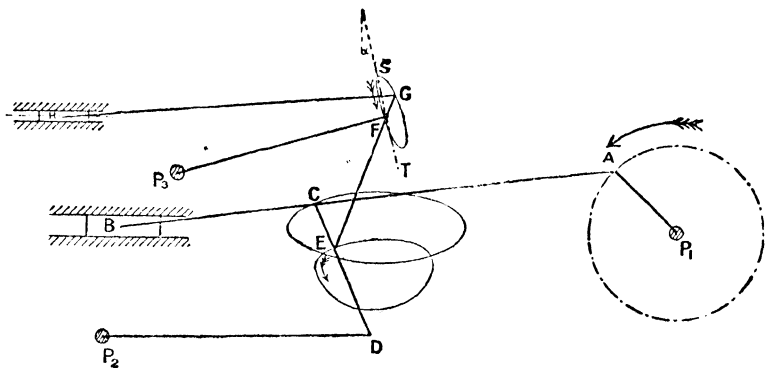

FIG. 262.

this gear, the link which corresponds to  $CD$  in the three previous cases is the link  $EF$  (Fig. 262). As already pointed out (§ 150), reversal is effected by shifting the centre  $P_3$ . The position of  $P_3$ , and the direction of motion shown in the figure, correspond to the go-ahead position. As the crank shaft rotates, the points  $C$  and  $E$  describe the closed oval curves shown, and the point  $F$  a circular arc of centre  $P_3$ ; the path of the point  $G$ , to which the valve rod is attached, being also shown. When reversed, the path of  $E$  is unaltered, but the paths of  $F$  and  $G$  are inclined in the opposite direction to the vertical.

As before, the first object is to find the equivalent cranks which may be assumed to actuate  $E$  and  $F$ ; and as the valve and piston move in a horizontal direction, we need only consider the horizontal

motions of E and F, their vertical motions having only a secondary effect. The horizontal travel of E may be obtained by finding the extreme horizontal positions of E; and these may be taken to be when the crank arm is horizontal. Moreover, since both E and B are in their extreme positions together, the equivalent crank actuating E has the same phase as the crank arm. Again, to find the horizontal travel of F, the mechanism must be plotted in the positions which give the extreme positions of F, and these may be taken to be when the crank arm is vertical. But the horizontal travel of F may be also found very approximately by remembering that the inclination of EFG to the vertical is small in all positions of the mechanism, and consequently the vertical displacement of every point in the link, such as F, is the same as that of the point E. The vertical displacement of E is found by finding the extreme vertical positions of E, and these may be taken to be when the crank arm is vertical. Moreover, since the angular motion of  $P_3F$  is usually small, the circular arc described by F may be imagined replaced by a straight line, ST, whose slope is the same as the average slope of the circular arc. The horizontal displacement of F will then be very approximately equal to the vertical displacement of E multiplied by  $\tan \alpha$ ,  $\alpha$  being the inclination of ST to the vertical. Care must be exercised in determining the angle  $\alpha$ .

Again, the equivalent cranks actuating E and F have not the same phase, but that actuating F is, as before,  $90^\circ$  in advance of the crank arm. This is evident, because when the piston is in its extreme position to the left, and is just commencing to move to the right, the point F is about at the middle of its swing, and is moving downwards towards the right. Thus F is about half a stroke ahead of the piston B; or, to express it differently, the equivalent crank actuating F is about  $90^\circ$  ahead of the crank arm, and therefore about  $90^\circ$  ahead of the equivalent crank actuating E. Thus, then, so far as their horizontal motions are concerned, the points E and F in the link EF may be imagined actuated by cranks set so that the crank for F is  $90^\circ$  ahead of that for E, and  $90^\circ$  ahead of the crank, the length of the crank for E being half the horizontal displacement of E, and that for F being half the vertical displacement of E multiplied by  $\tan \alpha$ .

The equivalent crank actuating  $G$  may then be found as before. Draw (Fig. 263)  $OA_1$  to represent the crank arm when the piston is at the back end of the stroke, and mark off  $OE_1$  equal to half the horizontal travel of  $E$ . Mark off, also,  $OE_2$  equal to half the vertical displacement of  $E$ , and through  $E_2$  draw a line making an angle  $\alpha$  with  $OA_1$  to meet a line through  $O$ , drawn  $90^\circ$  in front of  $OA_1$ , in  $F_1$ ; then  $OE_1$ ,  $OF_1$  represent the equivalent cranks which may be assumed to actuate  $E$  and  $F$ . Produce  $E_1O$  to  $g$ , so that  $\frac{E_1O}{E_1g} = \frac{EF}{EG}$  (Fig. 262), and draw a vertical line through  $g$  to meet  $E_2F_1$  in  $G_1$ ; then  $OG_1$  represents the equivalent crank actuating the point  $G_1$ , the half travel of the valve being  $OG_1$ , and its angular advance  $F_1OG_1$ . For different positions of the gear, the only thing that alters is  $\alpha$ , so that the new equivalent crank may be found as before, the angle  $\alpha$  depending on the position of the centre  $P_3$ . In the mid-position of the gear,  $\alpha$  is zero, the half travel is  $Og$ , and the angular advance  $90^\circ$ .<sup>1</sup>

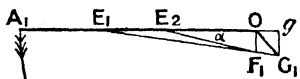

FIG. 263.

<sup>1</sup> For further information on the subject of radial valve gears, see Perry's "Steam Engine," chap. xxviii.

## CHAPTER VI.

### ACCELERATION DIAGRAMS.

§ 159. **Centripetal and Tangential Accelerations.**—In the preceding chapter, the velocity diagrams for a number of typical mechanisms have been drawn. In treating of the dynamics of machines, it is of great importance to know, not only the velocities, but also the accelerations of different points in the mechanism, and we now proceed to show how the latter may be obtained.

In the first place, it must be noticed that the direction of the velocity of a point is always in the direction of displacement of the point, but that this statement is not true for the acceleration of the point unless the point moves in a straight line. If the point

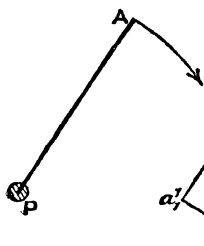

FIG. 264.

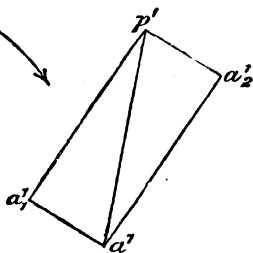

FIG. 265.

be moving in a curved path, the direction of acceleration is *not* the same as the direction of displacement. Thus, consider the case of a rod, PA (Fig. 264), of length  $r$ , rotating about a fixed centre, P, with uniform angular velocity  $\omega$ . The velocity of the point A is equal to  $\omega r$ ,

and is in a direction perpendicular to PA; the acceleration of A is equal to  $\omega^2 r$ , and acts in the direction of the radius from A to P. In this simple case, therefore, the direction of acceleration is perpendicular to the direction of motion. If the angular velocity of PA is varying, in addition to its *centripetal* acceleration about P, the point A has also a *tangential* acceleration

acting in a direction perpendicular to PA, and the total acceleration of A is the resultant of the two. The resultant acceleration may be obtained from the two components by the parallelogram of accelerations. Thus, let the centripetal acceleration of A be represented by the line  $p'a'_1$  (Fig. 265) drawn parallel to AP and equal, on some scale, to  $\omega^2 r$ , that is to say, to  $(\text{velocity of A})^2 \div \text{AP}$ ; also let the tangential acceleration be represented by  $p'a'_2$ , drawn perpendicular to PA, and equal to the angular acceleration of PA multiplied by the radius PA. The resultant acceleration of A is then represented, in magnitude and direction, by the diagonal  $p'a'$  of the rectangle, the direction being from  $p'$  to  $a'$ . Instead of actually drawing the rectangle, the two components  $p'a'_1$  and  $a'_1a'$  may be set off in order, and the closing line  $p'a'$  will represent the resultant.

The fact that the direction of acceler-

tion is different from that

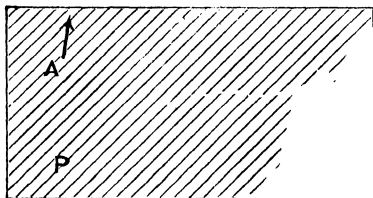

FIG. 266.

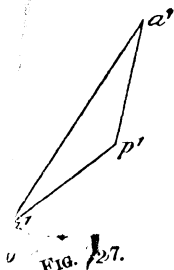

FIG. 267.

of motion at first com- disappears after one .

The general meth- described in the last- A and B (Fig. 266), to mo- accelerations, in magnitude an- 267) represent these acceleratio-

the acceleration of B relative to A is re- line  $a'b'$ , and acts in the direction from  $a'$  to  $b'$ . In fact, the acceleration of B over the base plate may be imagined made up of two parts, namely, the acceleration of A over the base plate, represented by  $p'a'$ , and the acceleration of B about A, represented by  $a'b'$ .

this difficulty soon worked out. similar to that very dependent points, so, P, with given set  $p'a'$ ,  $p'b'$  (Fig. 267), on the same scale; then the resultant acceleration is obtained by the joining line  $a'b'$ .

§ 160. **Acceleration Diagrams as applied to Mechanisms.**—Now, in any mechanism, the points A and B are not independent, but, in link work at least, the distance between them is invariable. If this condition be introduced, the *magnitudes* of the velocity and acceleration of B may be found, provided the velocity and acceleration of A, both in magnitude and direction, and also the *directions* of velocity and acceleration of B, are known. For example, suppose that the arrows in Fig. 268 represent the directions of motion of A and B. Then if  $pa$  (Fig. 269) represent the velocity of A,  $pb$  will represent the velocity of B, and  $ab$  that of B about A—the lines  $ab$  and  $AB$  being perpendicular to each other. Again, suppose that the arrows in Fig. 270 represent the directions of acceleration of A and B, and let  $p'a'$  (Fig. 271) represent, on some scale, the known acceleration of A. Through  $p'$  draw a line parallel to the direction of acceleration of B; then some length measured along this line will represent the acceleration of B, or, in other words, the acceleration of B about A. This acceleration of B about A consists of two parts, namely, the acceleration of B about A, represented by  $p'a'$ , and the acceleration of B about A, the acceleration of B about A consists of two parts, namely, the centripetal acceleration acting perpendicularly to  $AB$ , and the tangential acceleration acting perpendicularly to  $AB$ . The centripetal acceleration of B about A is known from the linear velocity of B, and is therefore equal to  $\frac{(ab)^2}{AB}$ , where  $ab$  is the linear velocity of B about A on the scale of velocity, and  $AB$  is the distance between A and B. The tangential acceleration of B about A cannot be directly calculated, but if a line be drawn through  $b'_1$  perpendicular to  $AB$ , it must be represented by some length measured along this line. The point  $b'$ , therefore, must be the point of intersection of the lines drawn through  $p'$  and  $b'_1$ , so that the diagram of acceleration is  $p'a'b'_1b'$ . In that diagram,  $p'a'$  represents the acceleration of A over the base plate,  $a'b'_1$  the centripetal

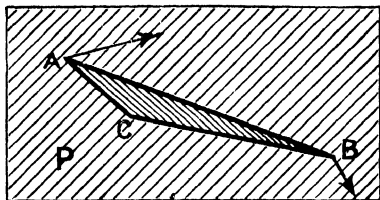

FIG. 268.

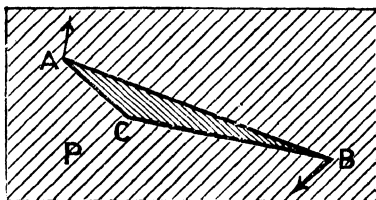

FIG. 270.

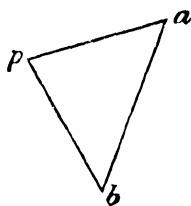

FIG. 269.

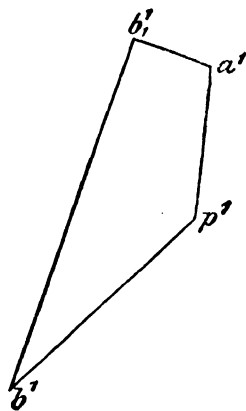

FIG. 271.

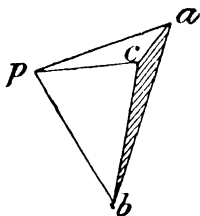

FIG. 272.

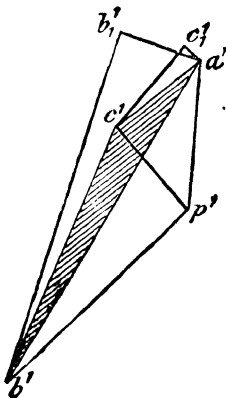

FIG. 273.

acceleration of B about A,  $b'_1b'$  the tangential acceleration of B about A, and  $p'b'$  the acceleration of B over the base plate. The angular velocity of B about A is  $\frac{(ab)}{AB}$ , and the angular acceleration is  $\frac{(b'_1b')}{AB}$ ; and the direction of both these is clockwise referred to A.

If a third point, C, be rigidly attached to the link AB, its velocity and acceleration may be readily found. The velocity is obtained by the method described in § 146, and is represented by  $pc$  (Fig. 272), the triangle  $abc$  being similar to the triangle ABC. To find the acceleration of C, first determine the acceleration of B, namely  $p'b'$  (Fig. 273) in the manner just described. The angular velocity and acceleration of AC about A are exactly the same as those of AB, and therefore, the centripetal and tangential accelerations of C about A bear the same relation to the centripetal and tangential accelerations of B about A as the length of the line AC bears to the length of the line AB. The acceleration of C over the base plate is the acceleration of A over the base plate, represented by  $p'a'$ , combined with the acceleration of C about A. The centripetal acceleration of C about A acts from C to A, and is represented by  $a'c'_1$ , where  $\frac{a'_1c'_1}{a'b'_1}$  is equal to  $\frac{AC}{AB}$  (Fig. 270); and the tangential acceleration of C about A is represented by  $c'_1c'$ , where  $c'_1c'$  is drawn perpendicular to AC and of such a length that  $\frac{c'_1c'}{b'_1b'} = \frac{AC}{AB}$ . The resultant acceleration of C over the base plate is then represented in magnitude and direction by  $p'e'$ .

If the points  $a'$ ,  $b$ ,  $c'$ , be joined, the triangle  $a'b'c'$  is obviously similar to the triangle ABC, since the ratio of corresponding sides, and the angles included by those sides, are equal in each triangle. To obtain the velocity and acceleration of points rigidly connected together, it is only necessary to describe lines on  $ab$  (Fig. 272) and  $a'b'$  (Fig. 273) which form figures similar to the mechanism figure. In each case the figure so described must, by rotation, be capable of having its sides placed parallel to the corresponding sides in the mechanism figure.

If the point  $C$  lie in  $AB$ , so likewise will the point  $c$  lie on  $ab$ , and  $c'$  in  $a'b'$ ; and, moreover, the ratios  $\frac{ac}{ab}$ ,  $\frac{a'c'}{a'b'}$ ,  $\frac{\Delta C}{\Delta B}$  will be equal.

To emphasize the method, let us apply it to a few typical mechanisms.

**161. Direct-acting Engine. Klein's Construction for the Acceleration of the Piston.**—Suppose, in the first place, that the

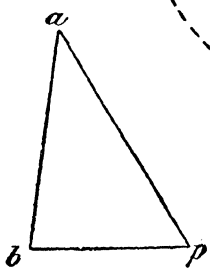
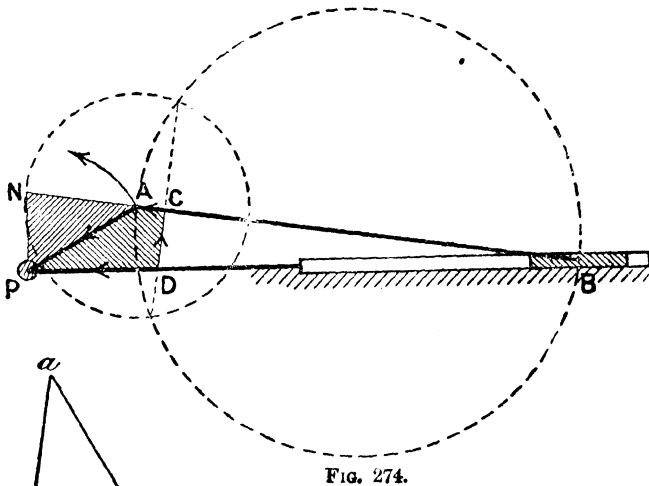

FIG. 275.

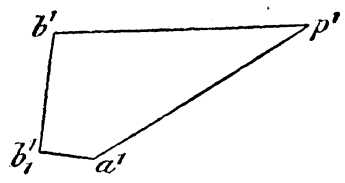

FIG. 276.

crank shaft rotates with uniform angular velocity; the object is to find the acceleration of the piston for any position of the mechanism. The mechanism diagram is shown in Fig. 274, and the velocity diagram in Fig. 275. To obtain the acceleration of the piston, draw  $p'a'$  parallel to the crank radius to

represent the centripetal acceleration of A, so that  $p'a'$  represents, on some convenient scale, the quantity  $\frac{(pa)^2}{PA}$ ,  $pa$  being read off on the scale of velocity, and PA on the scale of length. The acceleration of B is found by combining the acceleration of A over the base plate with that of B about A. The latter is made up of two components, namely, the centripetal acceleration of B about A, equal to  $\frac{(ab)^2}{AB}$ , which is represented by  $a'b'_1$ , drawn parallel to BA; and the tangential acceleration of B about A, which is not known, but which may be represented by some length measured along a line through  $b'_1$  drawn perpendicular to AB. The resultant acceleration of B is in the direction of the stroke, so that if a line through  $p'$  be drawn parallel to the stroke to meet the line through  $b'_1$ , the point of intersection will be the required point  $b'$ ; and thus  $p'b'$  will represent the acceleration of the piston, and  $b'_1b'$  the tangential acceleration of B about A. The velocity ratio of the piston and crank pin is  $\frac{(pb)}{(pa)}$ , and the acceleration ratio is  $\frac{(p'b')}{(p'a')}$ .

The scales to which the velocity and acceleration diagrams are drawn may be any convenient scales whatever. In particular, if the scale of velocity be such that the linear velocity of the crank pin is represented by a length equal to the crank radius, the diagram of velocities may be taken to be the triangle PAN (§ 148), so that if PA represents the velocity of the crank pin, NP will represent the velocity of the piston, and AN the velocity of B about A. The centripetal acceleration of the crank pin would then be represented by  $\frac{(PA)^2}{PA}$ , that is, by PA; and the centripetal acceleration of B about A by  $\frac{(AN)^2}{AB}$ . Thus, if the scale of acceleration be such that  $p'a'$  is equal to the crank radius, then  $a'b'_1$  will be equal to  $\frac{(AN)^2}{AB}$ . Suppose that the value of this last expression has been obtained, and that the distance AC (Fig. 274), equal to it, is marked off along the connecting rod; and that through C a line is drawn perpendicular to the connecting rod to meet the line of stroke in D. It is clear that the four-sided figure PACD will be

exactly similar to the acceleration diagram  $p'a'b'_1b'$ , so that if AP represent the centripetal acceleration of the crank pin, CA will represent the centripetal acceleration of B about A, DC the tangential acceleration of B about A, and DP the acceleration of the piston—the directions of the accelerations being shown by the arrows. We thus conveniently obtain, on the mechanism diagram, both the triangle of velocities, namely PAN, and also the diagram of accelerations, namely DCAP.

The distance CA can be either calculated, or it may be obtained geometrically. Many geometrical constructions may be devised, but one construction is to draw a circle with centre A and radius AN to intersect the circle drawn on AB as diameter. The common chord of the two circles cuts AB at right angles in the required point C, so that CD is the common chord. This construction is usually known as *Klein's construction*.

§ 162. **Curves of Acceleration of Piston.**—By repeating this construction for different positions of the mechanism, the acceleration of the piston at different points of the stroke may be obtained, and a curve of acceleration of the piston may be drawn just as before a curve of velocity was drawn. The curve may be plotted either on a piston or a crank angle base; that is to say, abscissæ may either represent the displacements of the piston, or the angle turned through by the crank arm. In either case the ordinate will be equal to DP, the vertical scale being such that AP represents the centripetal acceleration of the crank pin. If D (Fig. 274) lie to the right of P, the acceleration DP (the crank shaft being supposed to rotate counter clockwise) will be in the direction of motion of the piston; if D lie to the left of P, the acceleration is from left to right, and is therefore in the opposite direction to that of motion, and the piston is being retarded. The ordinate will then be plotted below the datum line to denote that the acceleration is negative. The general character of the curves obtained by proceeding in this way is shown in Figs. 277, 278, the connecting rod being taken three and a half times the length of the crank radius; Fig. 277 represents the curve of acceleration on a piston base, and Fig. 278 on a crank angle base—the diagrams referring to the motion of the piston from right to left, or of the upper

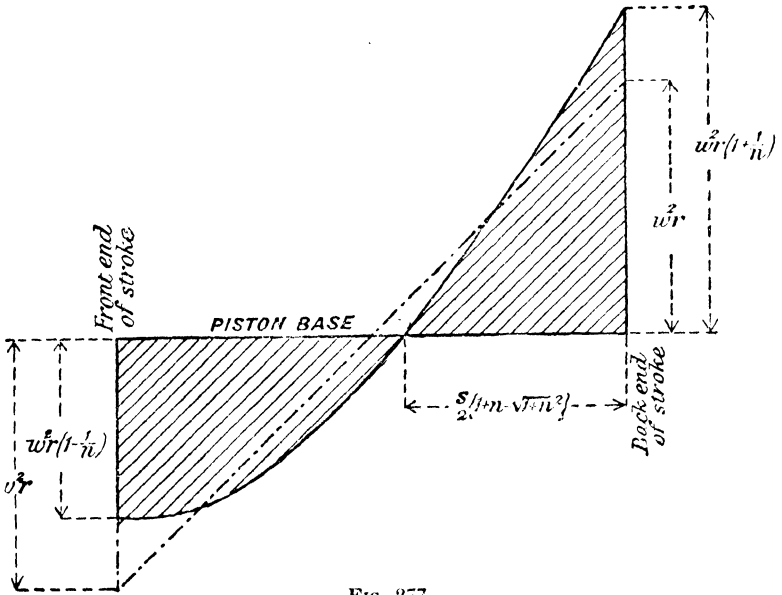

FIG. 277.

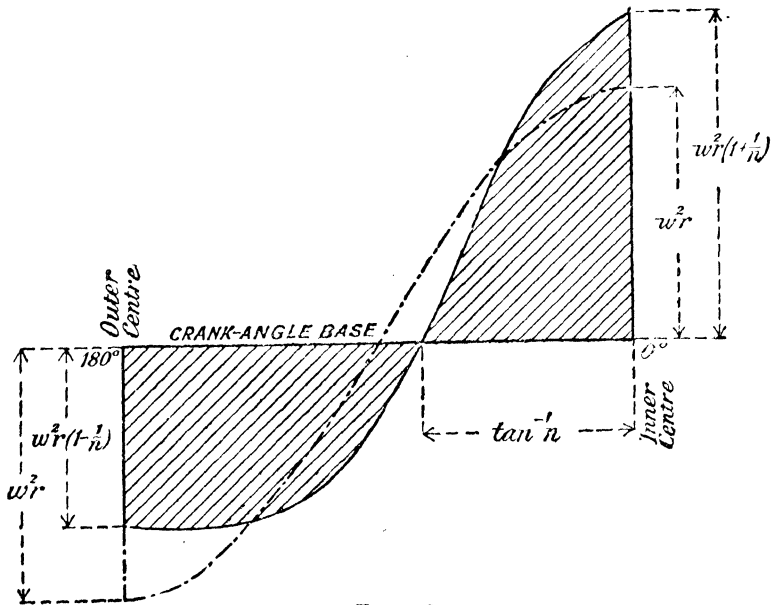

FIG. 278.

half of the crank-pin circle. For the return stroke, the curves will simply be reflections of the curves sketched. It will be noticed that the greatest negative acceleration takes place just before the back end of the stroke is reached; the reason for this is best seen analytically (§ 167). The three most important items connected with these curves are the accelerations when the piston is at the two ends of the stroke, and the position of the piston or crank arm for which the acceleration of the piston is zero.

§ 163. **Accelerations of Piston at the Two Ends of the Stroke.**

**Position of Piston for Zero Acceleration.**—When the crank pin is on the dead centres, the point N (Fig. 274) coincides with the point P, and the distance AN becomes equal to the crank radius  $r$ . The length of CA is then equal to  $\frac{r^2}{l}$ , where  $l$  is the length of the connecting rod; so that if  $r$  be taken to represent the centripetal acceleration of the crank pin, the acceleration of the piston at the back end of the stroke (that is to say, when the crank pin is on the inner dead centre) is  $(r + \frac{r^2}{l})$ , and the retardation at the front end of the stroke (that is to say, when the crank pin is on the outer dead centre) is  $(r - \frac{r^2}{l})$ .

Klein's construction, reproduced for these two positions, is shown in Figs. 279 and 280, the acceleration in each case being represented by DP. Thus, if  $\omega$  be the angular velocity of the crank shaft, the centripetal acceleration of the crank pin is  $\omega^2 r$ , and the acceleration and retardation of the piston at the back and front ends of the stroke are—

$$\omega^2 \left( r \pm \frac{r^2}{l} \right) = \omega^2 r \left( 1 \pm \frac{1}{n} \right)$$

respectively,  $n$  being the ratio of the length of the rod to the crank radius.

These results are exceedingly important, and may be obtained quite independently of the previous work. When the crank pin is on its inner dead centre (Fig. 279), the point A is rotating about P and also about B, and therefore the angular velocity of



a matter of fact, the angular acceleration of the rod in this position is zero. At the outer centre (Fig. 280), the acceleration of A about P is from left to right, so that the acceleration of the piston is  $\omega^2 r \left(-1 + \frac{1}{n}\right)$ , or the retardation is  $\omega^2 r \left(1 - \frac{1}{n}\right)$ , as before.

To find the position of the crank arm for which the acceleration of the piston is zero, the position of the mechanism must be found which makes the points D and P (Fig. 274) coincide. This happens when the crank arm has turned through a slightly greater angle, measured from the inner dead centre, than would make the crank arm and connecting rod perpendicular to each other. Thus,

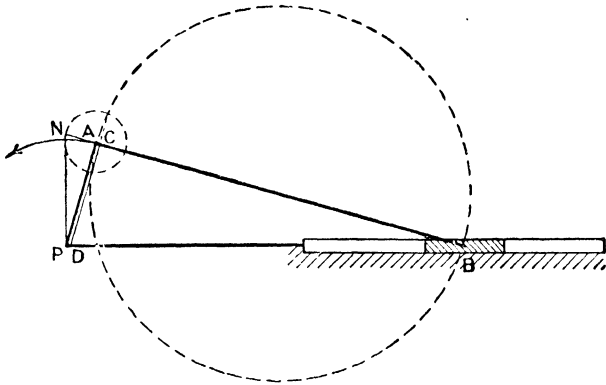

FIG. 281.

Fig. 281 shows Klein's construction repeated for the position of the mechanism in which the crank arm and connecting rod are perpendicular to each other. The common chord of the two circles is parallel to the crank arm, and the acceleration of the piston is represented by DP. It can be easily shown, from the geometry

of the figure, that the length of DP is  $r \frac{\sqrt{1+n^2}}{n^4}$ ; so that the acceleration of the piston, when the crank arm and connecting rod are perpendicular, is  $\omega^2 r \frac{\sqrt{1+n^2}}{n^4}$ ; and, for ordinary values of  $n$ ,

the multiplier of  $\omega^2 r$  is so very small that it may be invariably neglected.

For the acceleration to be truly zero, the position of the mechanism must be that shown in Fig. 282, in which the common chord passes through P. If  $\theta$  be the crank angle corresponding to this position, it may be readily shown, from the geometry of the figure, that  $\theta$  is given by the equation—

$$\sin^6 \theta - n^2 \sin^4 \theta - n^4 \sin^2 \theta + n^4 = 0$$

a cubic in  $\sin^2 \theta$  which can be solved by the ordinary approximate

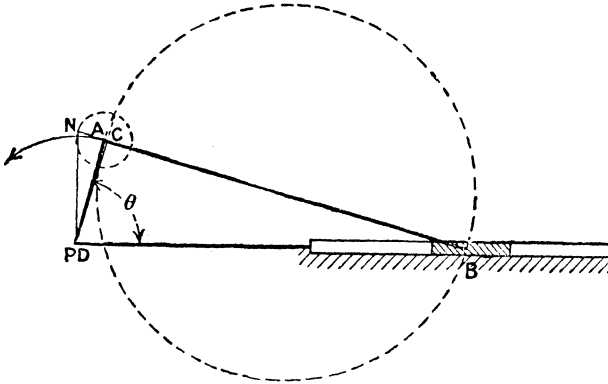

FIG. 282.

methods.<sup>1</sup> The value of  $\theta$  given by this equation differs very little from the value given by the equation—

$$\theta = \tan^{-1} n$$

which represents the value of the crank angle when the crank arm and connecting rod are perpendicular (Fig. 281). Thus, for example, when  $n = 4$ , the true value of  $\theta$  given by the cubic equation is  $76^\circ 43' 34''$ ; whilst the approximate value given by the second equation is  $75^\circ 57' 50''$ . These are so nearly equal that for all practical purposes the acceleration of the piston may be taken to be zero in the position of the mechanism for which the connecting rod is perpendicular to the crank. The corresponding crank angle is then  $\tan^{-1} n$ , and the distance of the piston from the back end

<sup>1</sup> First given by Rankine, "Machinery and Millwork," 1st edit., § 188.

of the stroke may be shown to be  $(1 + n - \sqrt{1 + n^2}) \frac{s}{2}$ , where  $s$  represents the stroke. Incidentally, when the acceleration of the piston is zero, its velocity is a maximum; and consequently the maximum velocity of the piston may be taken equal to  $\omega \cdot PN$  (Fig. 281), that is to say, to  $\omega r \sqrt{1 + \frac{1}{n^2}}$ . For  $n=4$ , the maximum velocity of the piston is thus about three per cent. greater than the crank-pin velocity, and the piston has moved through a distance equal to 0.43 of the stroke from the back end.

§ 164. **Curves of Acceleration neglecting Obliquity.**—It is interesting to compare the curves of acceleration given in Figs. 277, 278, with those which would be obtained if the connecting-rod were of infinite length. In that case the length AC (Fig. 274) will be zero in all positions, and the rod AB will be sensibly parallel to the stroke. Thus Klein's construction reduces to Fig. 283, in which PN represents the velocity, and DP the acceleration of the piston on the same scales that AP represents the velocity and centripetal acceleration of the crank pin respectively. This is obvious other-

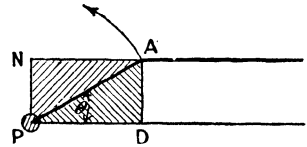

FIG. 283.

wise, because with an infinite rod, that is to say, a rod in which its obliquity to the line of stroke may be neglected, the motion of the piston is exactly the same as that of the point of projection of A, namely D. Considering the projection of the motion of A, the velocity of D is  $\omega r \sin \theta$ , that is,  $\omega \cdot PN$ ; and the acceleration is  $\omega^2 r \cos \theta$ , that is,  $\omega^3 \cdot DP$ ;  $\theta$  being the angle turned through by the crank arm measured from the inner dead centre. Thus, when the connecting-rod is of infinite length, the acceleration of the piston is  $\omega^2 r \cos \theta$  or  $\omega^2 x$ , where  $x$  is the distance of the piston from the point of mid-stroke. On a piston base, the curve of acceleration is a straight line which passes through the point of mid-stroke, and the end ordinates of which are equal to  $\pm \omega^2 r$ ; on a crank-angle base, the curve is a curve of cosines of maximum ordinate  $\omega^2 r$ . The curves are represented in Figs. 277, 278 by the broken-line curves, and the difference

between the full and broken curves represents the effect of the obliquity of the rod.

§ 165. **Acceleration of Piston when the Crank Shaft does not rotate at a Uniform Speed.**—The above results are only true provided the angular velocity of the crank shaft is constant. If the crank shaft does not rotate with uniform angular velocity, the acceleration of the crank pin is the resultant of the centripetal and tangential accelerations; but, with this exception, the work is exactly the same as before. Thus, for example, suppose that both the angular velocity

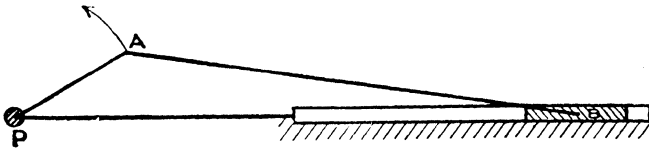

FIG. 284.

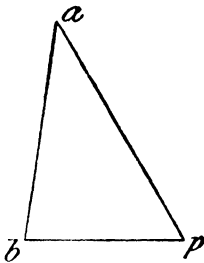

FIG. 285.

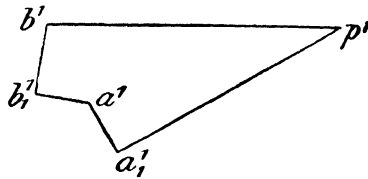

FIG. 286.

and acceleration of the crank arm are known. Let the mechanism diagram be as shown in Fig. 284, and draw, first, the diagram of velocities (Fig. 285), which will be exactly the same as before (see Fig. 275). The acceleration of the crank pin is then made up of the centripetal acceleration, represented by  $p'a'_1$  (Fig. 286), where

$p'a'_1 = \frac{(pa)^2}{PA}$ ; together with the tangential acceleration, represented

by  $a'_1a'$ . The direction of  $a'_1a'$  is perpendicular to the crank arm, and is equal in magnitude to the angular acceleration of the crank shaft multiplied by the length of the crank arm. In Fig. 286, it is drawn in the direction of motion of the crank pin, so that the crank shaft is being accelerated; if the crank shaft is being

retarded,  $a_1'a'$  must be drawn downwards instead of upwards. The resultant acceleration of the crank pin is then represented by  $p'a'$ , and this must be combined with the acceleration of B about A. The centripetal acceleration of B about A is  $a'b_1$  and is precisely the same as before (§ 161), provided the velocity of A is the same. The tangential acceleration is then  $b_1b'$ , and the acceleration of the piston is  $p'b'$ ; where  $p'b'$  is drawn parallel to the stroke to intersect  $b_1b'$ , drawn perpendicularly to the connecting-rod.

In all ordinary cases the effect of the tangential acceleration of the crank pin is so small compared to the centripetal acceleration that the former may be neglected in comparison with the latter. For example, take the case of a high-speed engine making 400 revolutions per minute, in which the stroke is 18 inches. The centripetal acceleration of the crank pin is  $(2\pi N)^2 \times r = 4,730,000$  feet per minute per minute. If the angular acceleration of the crank shaft is such that, if it remained constant for one minute, the revolutions in that interval of time would be doubled, the angular acceleration of the crank shaft will be  $800\pi$  radians per minute, and the tangential acceleration of the crank pin will be 1880 feet per minute per minute. Thus the centripetal acceleration is about 2500 times the tangential, and the length  $a_1'a'$  would therefore be inappreciable compared with the length  $p'a_1'$ .

§ 166. Relation between the Curves of Velocity and Acceleration on a Piston Base.—The curve of acceleration on a piston base, shown

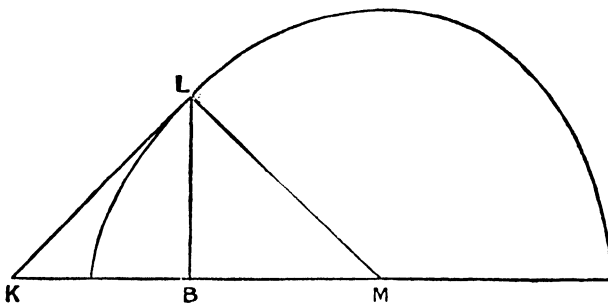

FIG. 287.

in Fig. 277, may be deduced directly from the curve of velocity of the piston, shown in Fig. 181. Thus, suppose that Fig. 287

represents the curve of velocity on a piston base, so that when the piston is in the position B, its velocity is BL. Draw the normal LM to the curve at L, meeting the datum line at M; then the subnormal BM represents the acceleration of the piston. To prove this statement, let  $v$ ,  $x$ , and  $t$  refer to velocity, displacement, and time. The acceleration of the piston is—

$$\begin{aligned} \frac{dv}{dt} &= \frac{dv}{dx} \cdot \frac{dx}{dt} = v \frac{dv}{dx} \\ &= BL \tan LKB \end{aligned}$$

where LK is the tangent to the curve at L,

$$\begin{aligned} &= BL \tan BLM \\ &= BM \end{aligned}$$

Thus, having drawn the curve of velocity of the piston on a piston base, the curve of acceleration may be at once deduced by drawing the normals at different points. To do so with any degree of exactitude is a very difficult matter, and therefore the former method of obtaining the acceleration diagram is to be preferred.

**§ 167. Approximate Solution in the Case of the Direct-acting Engine.**—By means of Klein's construction, or by drawing the acceleration diagram for a number of positions of the mechanism, the curves of acceleration may be obtained in the manner already described. The methods employed are mathematically exact, and the only possible errors are errors of drawing.

In many problems, it is necessary to obtain an analytical expression for the acceleration of the piston in terms of the crank angle  $\theta$ . It is not difficult to obtain an exact expression for the acceleration, but in the majority of cases the exact expression is too complicated for actual use. What is wanted is an analytical expression of a simple kind which, although not mathematically exact, is sufficiently near the true value for all practical purposes. Such an expression may be obtained as follows:—

Let the mechanism be as sketched (Fig. 288), and let the crank angle  $\theta$  be measured from the inner dead centre. The displacement of the piston from the point of mid-stroke is PM, where BM is made equal to BA; or, in other words, the displacement of the

piston (which will be denoted by  $x$ ) from the back end of the cylinder is  $A_0M$ . If the obliquity of the rod be neglected, the displacement would have been  $A_0M'$ , so that the actual displacement

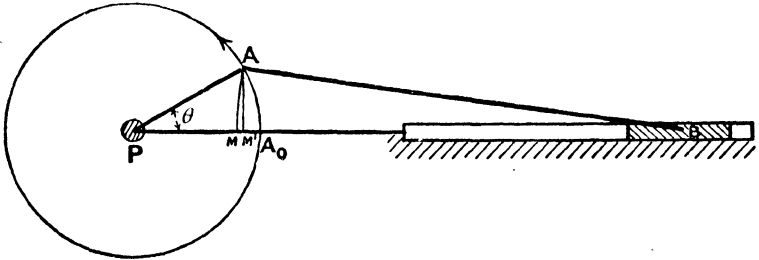

FIG. 288.

may be imagined made up of two parts, namely, the primary displacement,  $A_0M'$ , due to the motion of the crank, and the secondary displacement,  $M'M$ , due to the obliquity of the rod.

The primary displacement is equal to  $r(1 - \cos \theta)$ . The secondary displacement is equal to  $M'M$ ; that is to say, to

$$\begin{aligned} \frac{AM'^2}{(MB + M'B)} &= \frac{AM'^2}{2 \cdot BA} \text{ very approximately} \\ &= \frac{r^2 \sin^2 \theta}{2l} = \frac{r \sin^2 \theta}{2n}, \end{aligned}$$

where  $r$  and  $l$  are the lengths of the crank radius and connecting rod, and  $n$  is equal to  $\frac{l}{r}$ .

Thus, very approximately, the total displacement is given by—

$$x = r \left\{ (1 - \cos \theta) + \frac{\sin^2 \theta}{2n} \right\}$$

The velocity is therefore given by—

$$v = \frac{dx}{dt} = \omega r \left( \sin \theta + \frac{\sin 2\theta}{2n} \right), \text{ since } \omega = \frac{d\theta}{dt};$$

and the acceleration, assuming the crank shaft to rotate uniformly, so that  $\frac{d^2\theta}{dt^2} = 0$ , is given by—

$$\frac{d^2x}{dt^2} = \omega^2 r \left( \cos \theta + \frac{\cos 2\theta}{n} \right)$$

In each of these expressions, the first term represents the primary effect, that is to say, the effect of the crank arm alone when obliquity is neglected; the second term represents the secondary effect, that is to say, the effect (very approximately) of the obliquity of the rod. At the two ends of the stroke the expressions are exact, since they make the accelerations at the back and front ends  $\omega^2 r \left( 1 \pm \frac{1}{n} \right)$ .

A simple geometrical construction involving the approximate formula for the acceleration of the piston is as follows: Draw

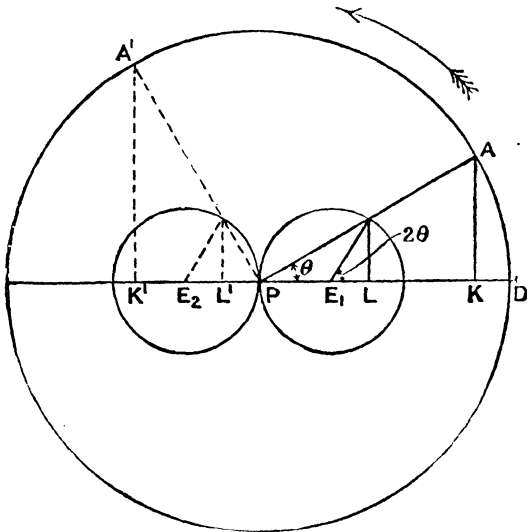

FIG. 289.

(Fig. 289) a circle having a radius equal to the crank radius, and also two smaller circles touching each other at P, with their centres,  $E_1$  and  $E_2$ , on the line of stroke produced, and of radii equal to  $\frac{1}{n}$  the crank radius. Then, if AP represent the centripetal acceleration of the crank pin, the primary acceleration of the piston when the crank pin is at A will be clearly represented by KP, and the secondary acceleration by  $LE_1$ ; the total, equal to their sum, being represented by DP. In any second position, such as PA', of the

crank arm, the primary effect is  $K'P$ , and the secondary  $L'E_2$ , and the net effect is the difference ( $K'P - L'E_2$ ), since they act in opposite directions. The piston in the second position is being retarded.

Again, using the approximate expression for the acceleration, or the above construction, the curves of primary, secondary, and total curves of acceleration may be drawn. On a crank-angle base the curves are as shown in Fig. 290, the value of  $n$

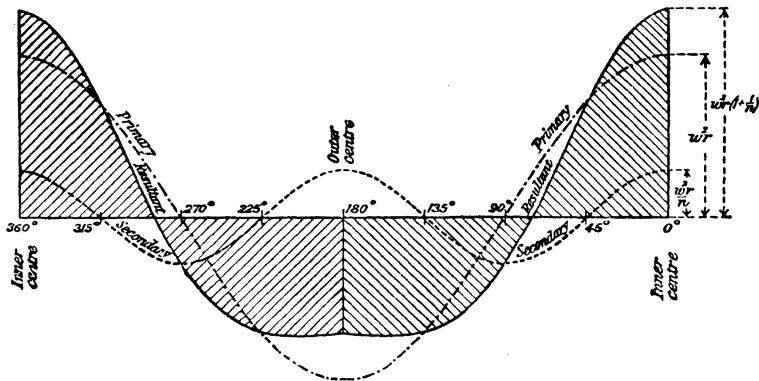

FIG. 290.

being  $3\frac{1}{2}$ . Both the primary and secondary curves are cosine curves, but the secondary curve has double the frequency of the first, and has only  $\frac{1}{n}$  the amplitude. The resultant curve, shown full, differs very slightly indeed from the curve of Fig. 278. The difference is, in fact, inappreciable, and for all ordinary purposes the approximate expression and construction may be used.\*

\* The true expression for the acceleration may be shown to be—

$$\omega^2 r \left\{ \cos \theta + \frac{\cos 2\theta}{n} + \frac{\sin^4 \theta}{n^3} \right\}$$

$$\left( 1 - \frac{\sin^2 \theta}{n^2} \right)^{\frac{3}{2}}$$

as against the approximate expression—

$$\omega^2 r \left( \cos \theta + \frac{\cos 2\theta}{n} \right)$$

At the ends of the stroke, the second formula gives the same result as the first.

Using the above approximate formula for the acceleration, the acceleration will be a mathematical maximum when—

$$\cos \theta = -\frac{n}{4}$$

If  $n = 4$ , this happens at the outer dead centres, so that the curves on a crank-angle base would be horizontal when the crank angle is  $180^\circ$ . If  $n = 3.5$ , as in Figs. 278, 290,  $\cos \theta = -\frac{3.5}{4} \therefore \theta = 151^\circ$  and  $209^\circ$ ; the curve is, therefore, horizontal at points corresponding to these angles. If  $n > 4$ , the curve is nowhere horizontal.

§ 168. Four-bar Chain.—

As a second example take the four-bar chain, and suppose that the shaft  $P_1$  (Fig. 291) rotates with known uniform angular velocity. The object is to find the angular velocity and acceleration of  $P_2$ .

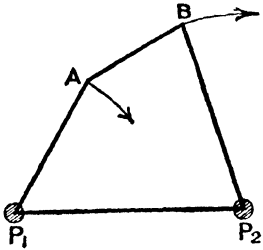

FIG. 291.

First draw the velocity diagram as before (Fig. 292). To obtain the acceleration diagram, draw  $p'a'$  (Fig. 293) parallel to  $AP_1$ , to represent on some scale the centripetal acceleration of A

about  $P_1$ ; it is numerically equal to  $\frac{(pa)^2}{P_1A}$ , and acts from A to  $P_1$ . The acceleration of B over the base plate is then the acceleration

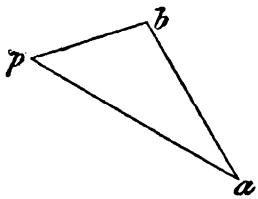

FIG. 292.

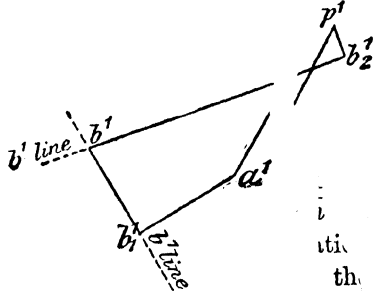

FIG. 293.

of A over the base plate, combined with the acceleration of B about A. The centripetal acceleration of B about A acts from B

to A, and is equal to  $\frac{(ab)^2}{AB}$ , and is represented by  $a'b'_1$ . The tangential acceleration of B about A is not directly known, but if a line through  $b'_1$  be drawn perpendicular to AB, the point  $b'$  must lie on that line. But the acceleration of B can also be obtained in another way, namely, by considering the rotation  $P_2B$  about  $P_2$ . The acceleration of B over the base plate is clearly its centripetal acceleration about  $P_2$ , combined with its tangential acceleration about the same centre. The former acts from B to  $P_2$ , and is equal to  $\frac{(pb)^2}{P_2B}$ , and is represented by  $p'b'_2$ . The tangential acceleration is not directly known, but the point  $b'$  must lie on a line through  $b'_2$  perpendicular to  $P_2B$ . The point  $b'$  must, therefore, be the point of intersection of this line and the line through  $b'_1$ , and thus the acceleration diagram is  $p'a'b'_1b'b'_2$ . In that diagram,  $p'a'$  represents the centripetal acceleration of A about  $P_1$ ,  $a'b'_1$  the centripetal, and  $b'_1b'$  the tangential accelerations of B about A; whilst  $p'b'_2$  represents the centripetal acceleration, and  $b'_2b'$  the tangential acceleration of B about  $P_2$ . The angular acceleration of the shaft  $P_2$  is therefore  $\frac{(b'_2b')}{P_2B}$ , the numerator being measured on the scale of accelerations, and the denominator on the scales of feet. The diagram shows that the acceleration is counter-clockwise, or that the shaft  $P_2$  is being retarded.

If the shaft  $P_1$  rotate with varying angular velocity, the necessary modifications can be made as in § 165.

§ 169. **Wigzell's Engine.**\*—As a quantitative example, take *Wigzell's engine*, a diagrammatic sketch of which is shown in Fig. 294. The engine has three cylinders, and the three pistons X, Y, Z, which move vertically along parallel lines in the same plane, operate on the same crank pin, A, through the triangular connecting-rod ACD.† The high-pressure piston (Y) is directly coupled to the rod at B; but the low and intermediate pressure piston rods (X and Z) are connected by short links, CE and DF.

\* For a description of this engine, see *Engineering*, September 7, 1900.

† The link AB is, kinematically, unnecessary, but is put in for greater clearness.

The scale of feet is as shown. The stroke of the high-pressure piston rod is 2. PA ; and the strokes of the intermediate and low

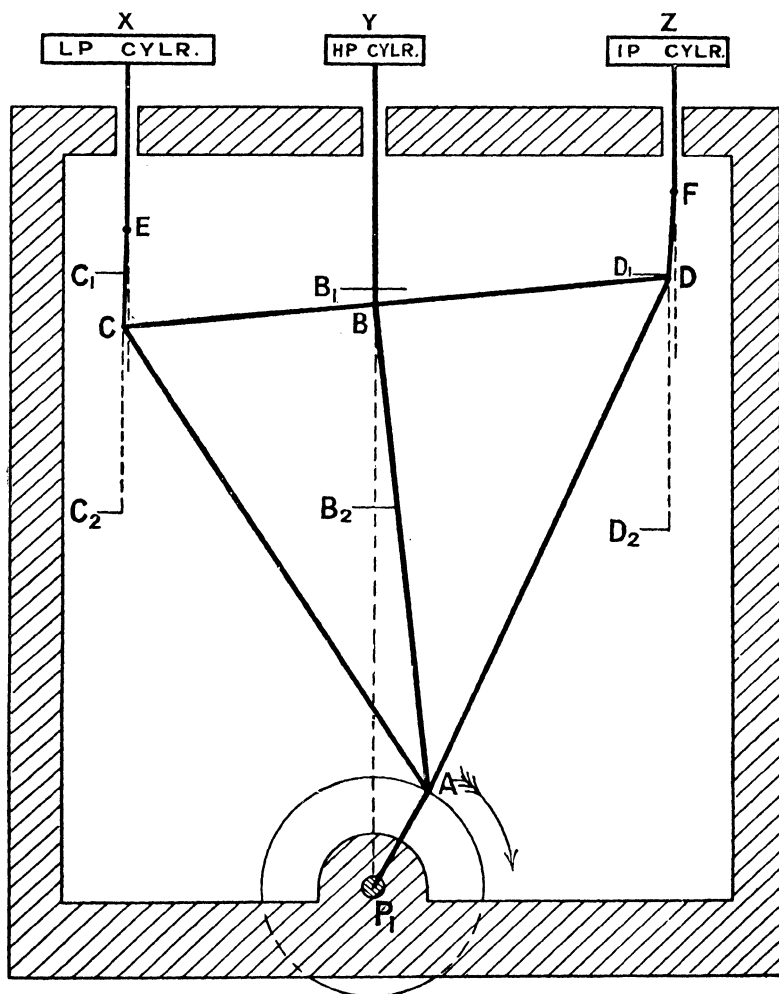

MECHANISM DIAGRAM



FIG. 294.

pressure pistons may very approximately be obtained (§ 114) by neglecting the obliquity of the links CE and DF, and assuming C and D to move in vertical lines. The three strokes are  $B_1B_2$ ,  $C_1C_2$ ,  $D_1D_2$ , and, in the engine considered, are 15, 16.6, and 17.6 inches respectively.

The diagram of velocities must first be drawn. The revolutions

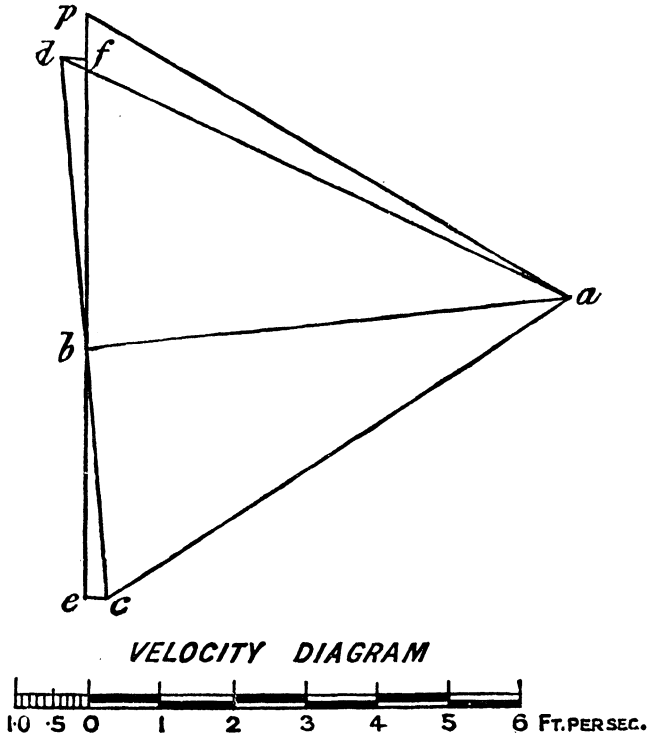

FIG. 295.

have been taken to 120 per minute, so that the circumferential velocity of the crank pin is (the crank radius being  $7\frac{1}{2}$  inches) 7.84 feet per second. The velocity diagram is shown in Fig. 295, the scale of velocity being appended. To obtain it,  $pa$  is first drawn to represent the velocity of the crank pin, and the velocity of B is then obtained by drawing  $ab$  perpendicularly to  $AB$  to

meet the vertical through  $p$  in  $b$ . To find the velocity of C, it must be remembered that C relative to B moves perpendicularly to BC, and relative to A perpendicularly to AC; the point  $c$  is, therefore, at once obtained. The point  $d$  may be obtained in a similar manner, and the triangle  $abcd$  will be exactly similar to the triangle ABCD, as explained in § 146. Having obtained the points  $c$  and  $d$ , the velocities of E and F are obtained by drawing lines through  $c$  and  $d$  perpendicular to CE and DF respectively to meet the vertical line through  $p$  in the points  $e$  and  $f$ . Then  $pe$ ,  $pb$ ,  $pf$  represent the velocities of the pistons X, Y, Z; and are respectively 8.1, 4.65, and 0.64 feet per second.

To draw the acceleration diagram, first take a length,  $p'a'$  (Fig. 296), to represent the centripetal acceleration of A. Since the velocity of A about P is 7.84 feet per second, and PA is 0.625 foot, the centripetal acceleration of A is 98.4 feet per second per second. The scale of acceleration is appended. The acceleration of B is obtained in the manner described in § 161. The velocity of B about A (namely,  $ab$ ) is 6.8 feet per second, and AB is 2.835 feet; hence the centripetal acceleration of B about A, represented by  $a'b'_1$ , is 16.3 feet per second per second. The acceleration of B, namely,  $p'b'$ , is obtained by drawing  $b'_1b'$  perpendicularly to AB to meet the vertical through  $p'$  in  $b'$ . To find the accelerations of C and D, describe on  $a'b'$  a figure,  $a'c'b'd'$ , exactly similar to the figure ACBD in the mechanism diagram (see § 160), care being taken that the sides of  $a'c'b'd'$  can, by rotation, be made parallel to the corresponding sides of ACBD. Having determined the point  $c'$ , the acceleration of E (that is, of the piston X) is obtained by combining the acceleration of E about C with that of C over the base plate, namely  $p'c'$ . The centripetal acceleration of E about C is  $\frac{(ce)^2}{CE}$ , and in the engine taken is  $\frac{0.32^2}{0.5}$ , that is, 0.205 feet per

second per second. This is so small that the length which represents it is inappreciable on the diagram, and has been omitted. The line drawn through  $c'$  perpendicular to CE to meet the vertical through  $p'$  in  $e'$ , will therefore give the point  $e'$ , and  $p'e'$  will be the acceleration of the piston X. Similarly, the centripetal acceleration of F about D is very small indeed, and  $d'$  is obtained by drawing  $d'f'$  perpendicular to DF to meet the vertical in  $f'$ ;

then  $p'f'$  represents the acceleration of Z. Thus, in the position of the mechanism sketched, the accelerations of the pistons X, Y, Z are 72.5, 97.5, and 127.5 feet per second per second respectively.

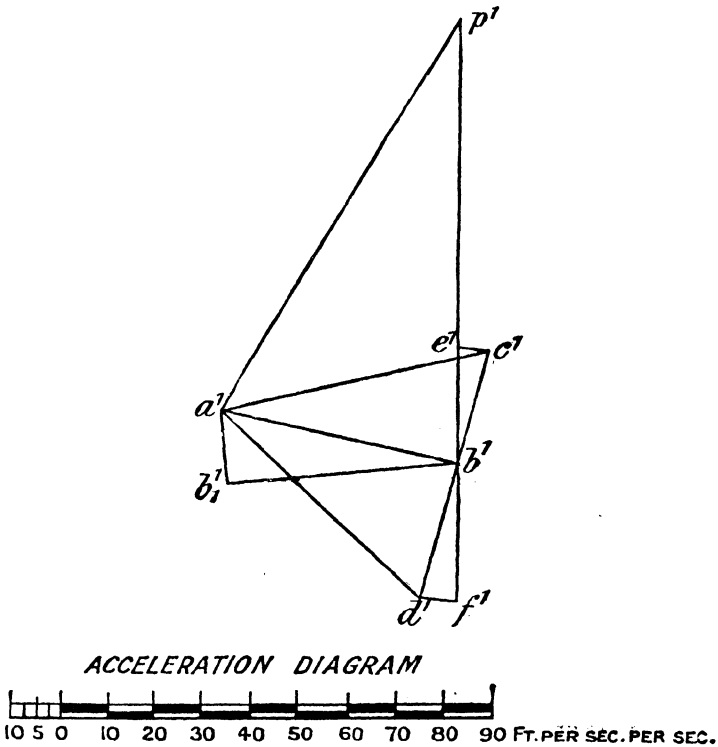

FIG. 296.

An approximate solution to the motion of the pistons X and Z may be obtained by the equivalent crank method described in § 154, the motion of the pistons being assumed to be the same as of the points C and D. This may be left as an example to the reader.

## CHAPTER VII.

### TOOTHED CIRCULAR WHEELS.

§ 170. **Problem of Toothed Wheels.**—With certain exceptions, the mechanisms so far discussed consist entirely of lower pairs, the elements being rigid links. The principal exceptions are those mechanisms in which spur or bevel gearing is used, and these comprise the greater part of Chapter II.

In ordinary spur gearing, the wheels rotate about fixed parallel axes, and, unless the wheels are provided with projecting teeth, the transmission of motion depends upon the frictional resistance between the cylindrical surfaces. But although motion can be transmitted by frictional resistance, the magnitude of the force is very small; and when the latter is considerable, the wheels must be provided with projecting teeth. In toothed wheels, the teeth of one wheel press on the teeth of the second wheel, and the motion is transmitted by direct action instead of by the frictional resistance to slipping. The problem is to give the teeth such a form that the motion transmitted by them is exactly the same as if the motion were transmitted by the rolling contact of the two pitch surfaces. In both cases, whether friction or toothed wheels be employed, contact is over a line, and therefore the two wheels form a higher pair.

§ 171. **Circular Spur Wheels. Definitions.**—Let us consider, in the first place, spur wheels. A section of the rim perpendicular to the axis is shown in Fig. 297. Referring to that figure, the outermost circle is called the *addendum circle*; the innermost circle, the *root circle*; and the circle intermediate between the two, the *pitch circle*. The portion *ab* of the surface of the tooth which lies between the addendum and pitch circles is called

the *face* of the tooth, and the portion *bc*, between the pitch and the root circles, is called the *flank*. The part of the tooth

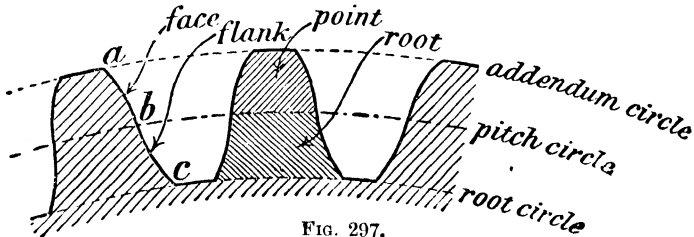

FIG. 297.

above the pitch circle is called the *point*, and the part below the pitch circle the *root* of the tooth. Fig. 298 shows a pair of wheels gearing together, one pair of teeth being shown just coming into gear, and a second pair just going out—the intermediate teeth, if any, not being shown. The chain-dotted circles are the pitch circles of the two wheels, their point of contact, *p*, being the *pitch point*.

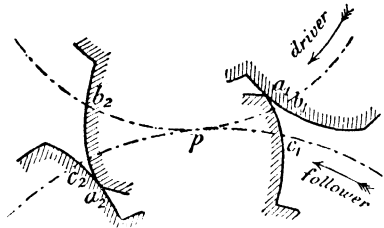

FIG. 298.

Clearly, during the time when the pair of teeth are approaching the pitch point (as in the first pair of teeth), the flank of the driver acts on the face of the follower; and when the teeth are receding from the pitch point (as in the second pair of teeth), the face of the driver acts on the flank of the follower. The first pair of teeth are shown coming into contact at *a<sub>1</sub>*, their profiles cutting the respective pitch circles in *b<sub>1</sub>* and *c<sub>1</sub>*. The points *b<sub>1</sub>* and *c<sub>1</sub>* will obviously coincide at the pitch point *p*, so that the arcs turned through by the two pitch circles during approach are *pb<sub>1</sub>* and *pc<sub>1</sub>* respectively. Since the motion as transmitted by the teeth has to be the same as that which would be transmitted by the rolling contact of the pitch circles, these arcs must be equal to each other, and the name usually applied to them is the *arc of approach*; the arc of approach, therefore, is the arc of either pitch circle over which there is contact during approach. For the same reason, if the second pair of teeth represent the position when

contact ceases, the arcs  $pb_2$ ,  $pc_2$  are equal to each other, and either is called the *arc of recess*. The sum of the arcs of approach and recess is called the *arc of contact*, so that the arc of contact is the arc of either pitch circle over which there is contact between a pair of teeth. The arc of approach clearly depends upon the radius of the addendum circle of the follower, and of recess upon the radius of the addendum circle of the driver. If the arc of contact is equal to the pitch, one pair of teeth are just coming into gear when the preceding pair are just going out. If the arc of action is twice the pitch, there are always two pairs of teeth in contact. Usually the arc of action is 1.5 times the pitch.

As motion is transmitted, slipping or sliding takes place between the teeth. The total amount of sliding during approach

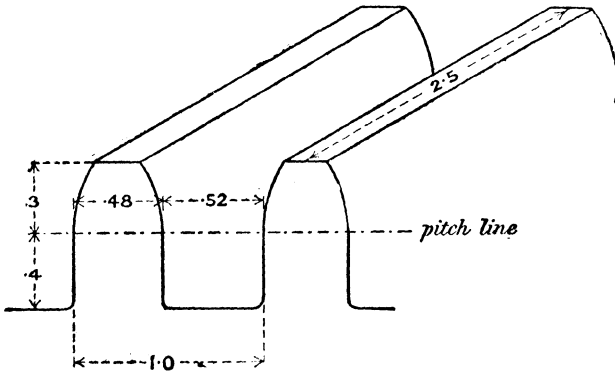

FIG. 299.

is clearly equal to the length of the face  $a_1c_1$  minus the length of the working flank  $a_1b_1$ ; and during recess is equal to the length of the face  $a_2c_2$  minus the length of the working flank  $a_2c_2$ . The total amount of sliding is, therefore, equal to the sum of the faces of the two teeth which gear together minus the sum of the working flanks. This sliding action necessitates the expenditure of a certain amount of energy to overcome the frictional resistance, so that the less the amount of sliding the better.

If the motion has to be transmitted in both directions, the tooth has to be shaped to the proper curve on both sides.

When transmitting power, the tooth is in the position of a cantilever, and its breadth and thickness, in relation to its height, must be such as to ensure sufficient strength when transmitting the maximum force. The most usual proportions of teeth are shown in Fig. 299, the unit of length being the pitch; but on this point reference must be made to works on machine design. The crests of one set of teeth must clear the hollows of the teeth of the other set, and the hollow space between the teeth must be greater than the thickness of the tooth in order to prevent jamming. The less, however, the side clearance, the less the "back-lash" between the teeth.

§ 172. **Kinematic Condition that has to be satisfied by the Profiles of Teeth. Velocity of Sliding.**—The profiles of a pair of teeth have to be such that the two teeth, by direct contact, transmit precisely the same motion as the two pitch circles would transmit by rolling contact; and to find the kinematic condition that has to be satisfied, we may proceed in the following manner. In Fig. 300, let the circles having centres  $P_1$  and  $P_2$  be the pitch circles A and B, the pitch point being K; and let L and M be the shapes of the teeth on the two wheels. At their point of contact, D, these surfaces must, for smooth working, have a common tangent. The relative motion of the two teeth is exactly the same whether each wheel rotates about a fixed centre, or whether the lower wheel is fixed, and the arm  $P_1P_2$ , carrying the upper wheel with it, rotates about  $P_2$ . In the latter case—since the motion is the same as if the pitch circles rolled on each other without slipping—the instantaneous centre of the upper wheel (that is to say, the point about which, at the instant, it is rotating) relative to the lower one, is the point K (§ 112). The point  $l$ , in the profile of L, which is coincident with the point of contact, is therefore moving perpendicularly to  $Kl$ ; and since the relative motion of the teeth is tangential to either surface, it follows that  $Kl$  is the common normal to the teeth at their point of contact. The only kinematic condition therefore, that has to be satisfied is, that the common normal to the two teeth at the point of contact must always pass through the pitch point. If the upper pitch circle roll over the lower

one, the successive positions of the tooth L will be as shown, the above condition being satisfied for each position. Provided the teeth keep in gear, the successive positions of L must touch

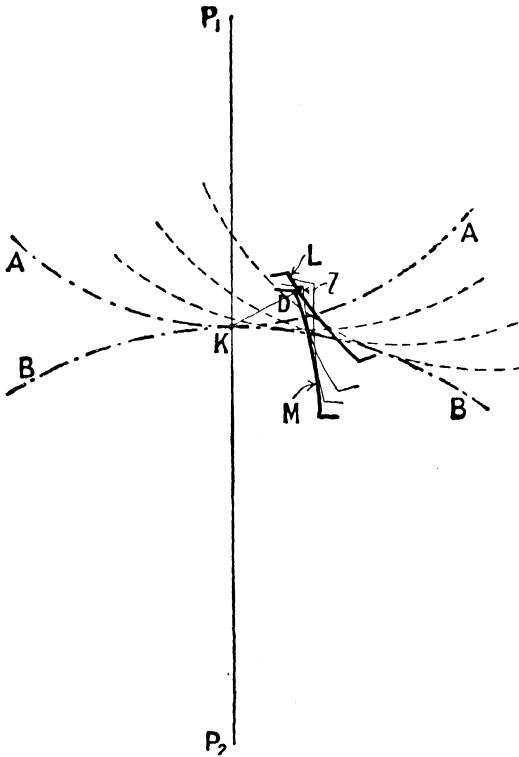

FIG. 300.

the tooth M; or, in other words, the shape of M is the envelope of the successive positions of L (§ 5). Knowing, therefore, the shape of the tooth L, the profile of L may be drawn in successive positions as the upper pitch circle rolls on the lower one; and, by drawing a curve to touch the successive positions of L, the proper shape for M may be obtained.

Again, the angular velocity of the upper wheel about the point K has been shown (§ 112) to be  $\omega_1 + \omega_2$ , where  $\omega_1$  and  $\omega_2$  are the angular velocities of the two wheels when they rotate about fixed axes; consequently, the velocity with which the tooth L is sliding

over the tooth  $M$  is, at any instant, equal to  $(\omega_1 + \omega_2) \cdot KD$ . Since the relative velocity of sliding is the same whether one wheel is fixed and the other roll outside it, or both wheels rotate about fixed axes, it follows that the velocity of sliding of a pair of teeth in any position is proportional to the length of the common normal measured from the point of contact to the pitch point. If the wheels gear internally, the velocity of sliding is  $(\omega_1 - \omega_2) \cdot KD$ .

In designing toothed wheels, it is necessary to have profiles which by rolling contact will transmit a uniform velocity ratio; but the *most important thing of all is to have an accurate pitch*.

§ 173. To determine the Shape of a Tooth to mesh with a Given Tooth. *First: Graphical Method of Poncelet.*—Instead of actually plotting the tooth  $L$  in different positions, as above described, the following geometrical construction (due to *Poncelet*) may be used. Let  $LK$

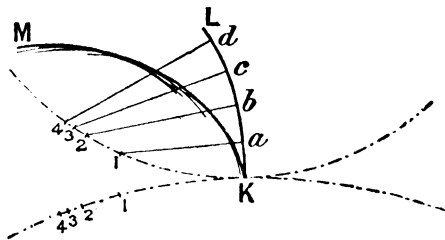

FIG. 301.

(Fig. 301) be the profile of the flank of the tooth on the upper wheel; take any number of points,  $a, b, c, \dots$ , in the curve, and draw, as accurately as possible, normals to the profile to cut the upper pitch circle in the points 1, 2, 3, . . . . Mark off on the lower pitch circle points 1, 2, 3, . . . such that the arcs  $K1, K2, K3 \dots$  are equal for each pitch circle.<sup>1</sup> With the points on the lower pitch circle as centres, and radii equal to the lengths of the corresponding normals  $a1, b2, c3 \dots$ , describe circular arcs; and draw, as accurately as possible, a curve,  $MK$ , to touch or envelope these circles. The curve so obtained is the face of the tooth on the lower wheel which will correctly gear with the flank  $LK$ . This follows from the fact that if the upper pitch circle rolls, without slipping, on the lower one, any pair of corresponding points, such as those marked 1, will ultimately coincide (since the arcs along the pitch circles have been made equal); and when they do

<sup>1</sup> See footnote to § 186.

coincide, the two curves will have the same common normal (since the lengths of the normals have been made the same). There will, of course, be slipping, the total amount of which will be the difference between the lengths of the arcs MK and LK. The flank of the second tooth to gear with the given face of the first can be drawn in a similar manner.

*Second: Mechanical Methods of Willis and Hele-Shaw.*—The same problem may be solved mechanically in the following way (due to *Willis*). Let the pitch circles be replaced by a pair of circular boards, A and B, and to one of them, A, attach a template, L, of the tooth whose shape is given (Fig. 302).

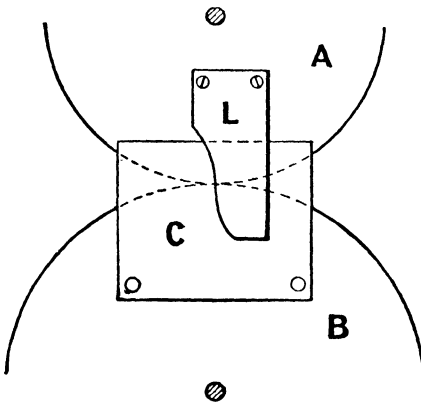

FIG. 302.

To the other, attach a piece of drawing-paper, C, the template L being slightly raised above the surface of the board A in order to allow the paper to pass under it. Then, keeping the circular boards in contact, make the board A roll, without slipping, over the fixed board B, and draw upon C, in a sufficient number of successive

positions, the outlines of the edge of L. The curve which touches all these successive outlines will be the corresponding tooth required for B. The same outlines and the same curve will obviously be obtained if the two boards rotate, in rolling contact, about fixed centres, the only difference being that the paper C will be carried round with B, and the outlines will be drawn on a moving sheet of paper instead of a fixed one.

This mechanical method has been developed very fully by *Hele-Shaw*.<sup>1</sup> The boards are replaced by two sheets of drawing-paper, turning on drawing-pins attached to the board as centres; and the angular motion of the sheets is not obtained by the rolling

<sup>1</sup> "Report British Association for the Advancement of Science," 1898, p. 619.

contact of the pitch circles, but by using milled rollers of small thickness. Thus, in Fig. 303, the two sheets are represented by A and B, the pins about which they rotate by  $P_1$ ,  $P_2$ , and the drawing-board by D, the point K being the pitch point. Two milled rollers, E and F, of equal diameter, are fastened to the same spindle, the axis of the spindle being parallel and immediately over the line of centres  $P_1P_2$ . The spindle rotates in holes at the end of the arms, G and H, of a frame which is pivoted at the edge of the board in such a way that the arms may be readily turned over; and, moreover, the frame carrying the spindle can be moved

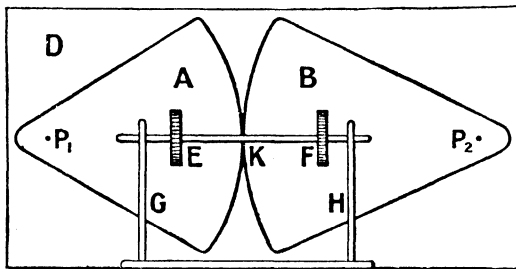

FIG. 303.

along the board, and, consequently, the position of the rollers E and F in the line of centres varied. When in position, they are pressed on the paper by weights or a spring. Underneath the board is an exactly similar spindle carrying a second pair of milled rollers, the paper A passing between rollers at E, and the paper B at F. If A be given a slight angular displacement, the roller E rotates, and B, through the roller F, will receive a corresponding displacement. If the motion is the same as if the pitch circles were in rolling contact, the angular displacements of the two sheets must be inversely as the radii of the pitch circles, and for this condition to be satisfied the rollers must be placed in a certain position in the line of centres. To find the proper position, let the sheet A receive an angular displacement  $\theta$ , so that, neglecting slipping, the spindle carrying the milled rollers will move through the angle  $\theta \cdot \frac{P_1E}{r}$ , where  $r$  is the radius of either roller. The

angle turned through by the sheet B will then be  $\theta \cdot \frac{P_1E}{r} \cdot \frac{r}{P_2F}$   
 or  $\theta \cdot \frac{P_1E}{P_2F}$ . This has to be equal to  $\theta \cdot \frac{P_1K}{P_2K}$ ; whence—

$$\frac{P_1E}{P_2F} = \frac{P_1K}{P_2K} \quad \text{or} \quad \frac{EK}{EF} = \frac{P_1K}{P_1P_2}$$

This relation can always be satisfied by shifting the frame carrying the spindle along the board; and thus, by the use of milled rollers, the pitch circles may be dispensed with.

To use the instrument, the sheet A is cut out to represent a section of the teeth of the first wheel, and the second sheet B passes under A as shown in Fig. 304. The outline of the teeth of

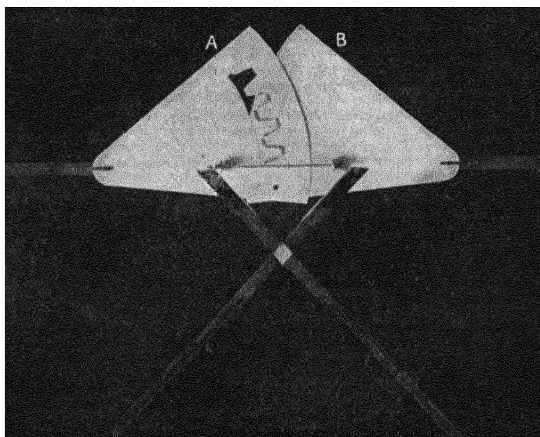

FIG. 304.

A is then traced on the sheet by a pencil. The sheet A is given a small angular motion (by hand), so that B simultaneously receives its proper angular motion, and the outline of A is again traced on B. This is done for a sufficient number of successive positions, and thus, on B, a considerable number of curves are traced out. The envelope of these curves is the proper shape for the teeth on B.

Figs. 305, 306 show curves obtained in this way. In each of these figures A represents the template, that is to say, the sheet from which the teeth of the first wheel are cut, as shown in Fig. 304, the section of the teeth being shown black. The lower sheet, B, represents the results obtained by scribing on B the teeth of A in the manner just described—the two sheets having been separated for clearness. The successive positions of A can be

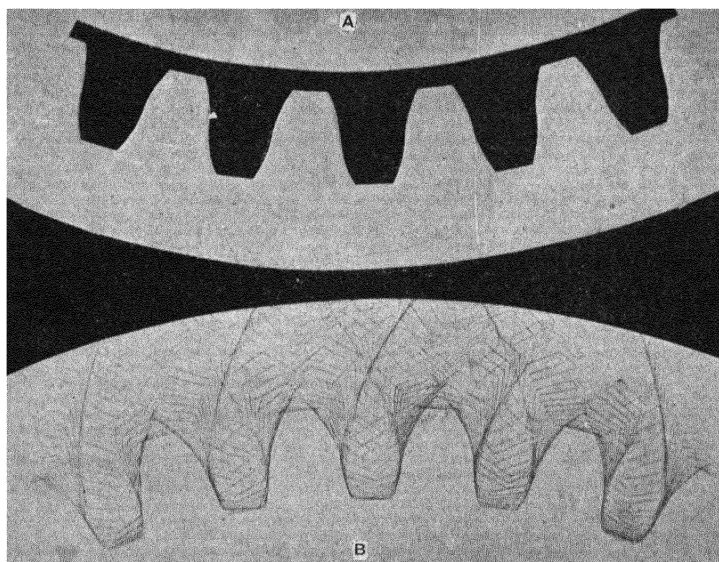

FIG. 305.

readily followed, and their number has been taken so large that it is not necessary to draw their envelope. In Fig. 305 the teeth of A are of normal shape, and no difficulty presents itself as regards the corresponding shape of teeth of B; but in Fig. 306 the teeth of A have radial flanks and faces, and in this case the outlines of the curves on B are somewhat peculiar. It will be noticed that a portion of the envelope required for contact with the flank of the teeth on A is swept away or removed as the selected profile on A is going out of gear; hence it would be

impossible to find an envelope corresponding with the selected form of A which would work smoothly in all positions. We could not, in fact, avoid "back-lash" as the tooth came into gear.

The problem here discussed of finding the proper profile for a curved plate which will correctly gear with another plate whose shape is fixed has, as already explained, its chief application in ordinary toothed gearing; but the same problem also occurs in

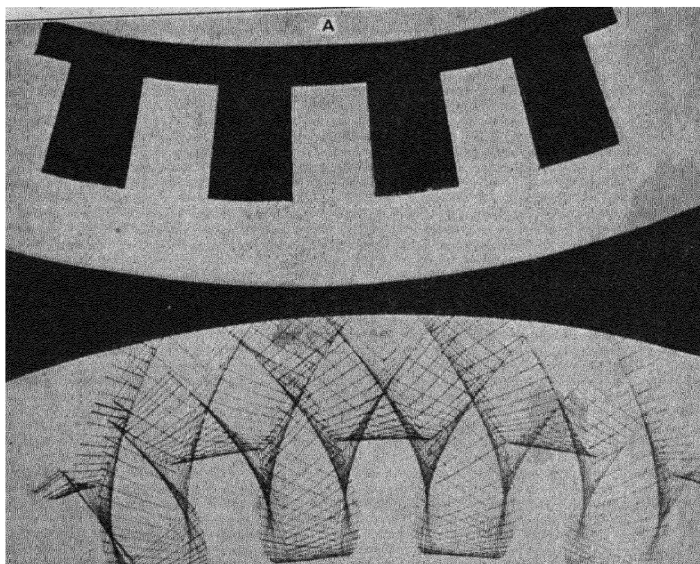

FIG. 306.

rotary blowers and pumps. We shall first confine our attention to toothed gearing, returning to the question of blowers in § 197.

§ 174. Profiles which are suitable for Toothed Wheels. Conditions to be satisfied.—The methods just described enable us to obtain, either graphically or mechanically, the profile of the tooth on the second wheel to gear correctly with a given tooth on the first wheel. As the form of the first tooth is arbitrary, there is, theoretically, an infinite choice; but in many cases, although the profiles are geometrically accurate, the shapes will be found

unsuitable in practice. It might happen, as in Fig. 306, that the selected profile for the first tooth necessitates a looped form for the profile of the second tooth; but even when this case does not arise, there are two considerations which limit the choice. In the first place, neglecting friction, the line of action of the force between two teeth is the common normal at their point of contact. If the angle between the common normal and the line of centres is comparatively small, the tangential or effective component of the force between the teeth will be small; and, in addition, the component of the force along the line of centres will be large. There would, therefore, be a small driving force and a large pressure on each bearing, with consequent excessive frictional losses; and in order to obviate these defects, the angle between the common normal to the two teeth and the line of centres must not be less than a certain angle, which usually is  $60^\circ$ . A second consideration which limits the choice of profiles is, that if the motion has to be transmitted in both directions, the teeth must be shaped to the proper curves on both sides, and the section of the tooth must be such as to ensure strength; or, in other words, it must not be unduly weak at the root.

In designing toothed wheels, there is generally nothing in the conditions of the problem which, *a priori*, fixes the profile of one of the teeth. The problem is to obtain *any* two profiles which, whilst satisfying the kinematic condition that the common normal to the two teeth should always pass through the pitch point, also satisfies the two conditions just laid down; namely, that the angle between the common normal and the line of centres shall not be less than a given angle, and that the tooth is not weak at the root. In practice the only teeth used are *involute* and *cycloidal* teeth.

§ 175. *Involute Teeth*.—Involute teeth possess the characteristic feature that, in all positions, the common normal to the two teeth is inclined at the same angle with the line of centres; hence, since the common normal must always pass through the pitch point, the same line always gives the direction of the common normal. In Fig. 307, let  $P_1, P_2$  be the centres of the two pitch circles A and B, K their pitch point; and let the straight line EKF, drawn through the pitch point, represent the constant direction of the common

normals. With  $P_1$  and  $P_2$  as centres, draw circles  $G$  and  $H$  (called the *base circles*) to touch this line; and imagine the base circles

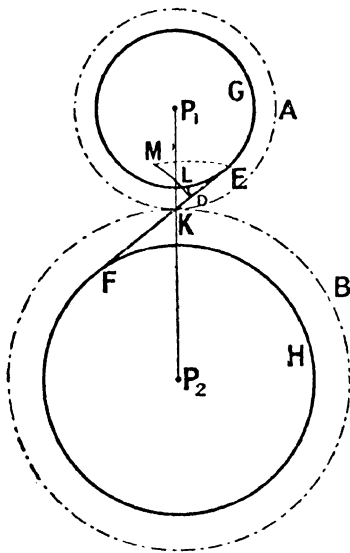

FIG. 307.

replaced by a pair of circular pulleys connected by an endless cord,  $GEKFH$ , which wraps round each of them. Clearly, the motion as transmitted by the rolling contact of the pitch circles will be exactly the same as would be transmitted by the base pulleys and, therefore, the addition of the belt or cord does not constrain the motion of the pitch circles in any way. A pencil fixed to the cord at the point  $D$  will move along the line  $EKF$ , and, as the motion takes place, will trace out a certain curve on a plane rotating with the wheel  $A$ . The curve so traced out will be the same under all conditions (since the combination forms a closed kinematic chain) and will be the same as if the wheel  $A$ , and therefore also  $G$ , were fixed and the cord  $DEG$  wrapped tightly round it. It will, consequently, be the *involute* of the base circle  $G$ .<sup>1</sup> In the

mechanism chain) and will be the same as if the wheel  $A$ , and therefore also  $G$ , were fixed and the cord  $DEG$  wrapped tightly round it. It will, consequently, be the *involute* of the base circle  $G$ .<sup>1</sup> In the

<sup>1</sup> The shape of the involute might either be obtained mechanically or geometrically. To draw it mechanically, make a template of  $G$  (Fig. 308), that is to say, cut out a circular board having the same radius as  $G$ . Wrap round  $G$  a piece of string, and attach a pencil at the end of the string. Keeping the string tight, gradually unwrap the string, and so trace out the required curve. From the method of obtaining the curve, it is evident that the arc  $EJ$  is equal to the length of the line  $ED$ , and that the line  $ED$  is normal to the curve at the point  $D$ . To draw the curve geometrically, take (Fig. 309) a length of arc  $JE$  of the base circle, which subtends, say, an angle of  $90^\circ$  at the centre, so that the length of the arc can be readily calculated. At  $E$  draw

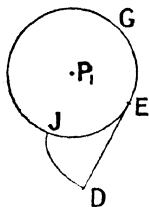

FIG. 308.

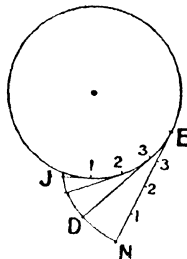

FIG. 309.

At  $E$  draw

same way, if the pencil be allowed to trace out a curve on the plane attached to the rotating wheel B, that curve will be the involute of the base circle H. Thus, if the pencil is initially in the position E, by the time it has reached D, it will have described the involute LD on the plane of A, and the involute MD on the plane of B, the difference in length of these two curves representing the amount of slipping that has taken place. These two curves will always cut the line FE at right angles, and therefore FE is the common normal to the two curves; and since the common normal always passes through the pitch point, the two curves satisfy the necessary kinematic condition, and are consequently suitable for the profiles of teeth. The teeth thus shaped are called *involute* teeth, and the angle between the common normal FE and the common tangent to the pitch circles at the pitch point is called the *obliquity*. The locus of the point of contact of the teeth, or the *path of contact*, as it is termed, is, for involute teeth, a straight line, namely, the straight line EF.

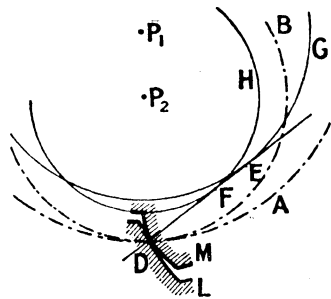

FIG. 310.

If the teeth gear internally, precisely the same construction may be followed, the only difference being (Fig. 310) that the centres of the base circles are on the same side of the path of contact.

§ 176. **Advantages of Involute Teeth.**—Involute teeth have many advantages over teeth of other shapes. In the *first* place, the flank and face are made up of a continuous curve, and the tooth is thickest at the root, so that strength considerations are readily satisfied (Fig. 311). In the *second* place, the obliquity is constant, and

a tangent to the circle, and mark off the length EN equal to the length of the arc EJ. Divide the arc JE, and also the distance NE, in the same number of equal divisions at the points 1, 2, 3, etc. (in the figure the arc and line have been divided into four equal divisions). At the points of subdivision of the arc draw tangents to the circle, and measure off tangents equal in length to N1, N2, N3. . . . The points, such as D, so obtained will be on the required involute, and the tangent, such as D3, to the base circle will be the normal to the involute.

can be made sufficiently small to prevent undue pressure on the bearings. The usual value of the obliquity is  $14\frac{1}{2}^\circ$  or  $15^\circ$ . Also, if a number of wheels have to gear with one another, the only condition

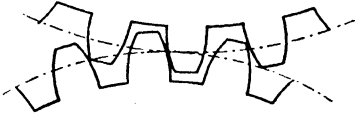

FIG. 311.

that has to be satisfied—in addition to having a common pitch—is that the obliquity must be the same for all the wheels. If this condition is not satisfied, the teeth in the different wheels will not

have, when meshing, a common normal. In the *third* place, the velocity ratio of a pair of wheels having involute teeth is inversely as the radii of the base circles, and depends on this ratio alone. If the distance between the centres of the wheels be altered, they will continue to work correctly together, and to preserve their constant velocity ratio—so long, that is to say, that they are sufficiently near for the wheels to gear, and sufficiently far apart for the crests of each set of teeth to clear the hollows between the teeth of the other set. In other words, the amount of back-lash can be varied at will, and may be adjusted so as to be no greater than is absolutely necessary in order to prevent jamming of the teeth—a property not possessed by teeth of any other shape. If the distance between the centres be altered, the pitch circles, the pitch measured along them, and the obliquity will also be altered; but the ratio of the radii of the new pitch circles will be the same as of the old. Moreover, two or more wheels of different numbers of teeth, turning about one axis, can be made to gear correctly with one wheel; and thus differential motions of various sorts can be accurately obtained.

The general extension of the method just described of obtaining two suitably shaped profiles is discussed in § 208.

#### § 177. Cycloidal Teeth. Minimum Diameter of Rolling Circle.

—In involute teeth, the path of contact is a straight line; in cycloidal teeth, it is an arc of a circle. The most convenient method of treating cycloidal teeth is as follows: Let  $P_1$ ,  $P_2$  (Fig. 312) be the centres of the pitch circles A and B, and  $R_1$  the centre of a third circle, C (called the *rolling* circle), which is in contact with the two pitch circles at their pitch point K. If A

rotate counter-clockwise, B will rotate clockwise and C counter-clockwise with angular velocities inversely as the radii. A pencil, D, attached to the circumference of C, will trace out certain curves on planes attached to A and B; and these curves will be the same under all conditions, since the combination is a closed kinematic chain. Now, if the wheel A be imagined fixed, and the wheel C roll, without slipping, inside it, the curve traced out by the pencil D is the *hypocycloid*  $L_1DL_2$ ; and if B be fixed and the curve C roll outside it, the pencil will trace out on the plane of B the *epicycloid*  $M_1DM_2$ .<sup>1</sup> If the

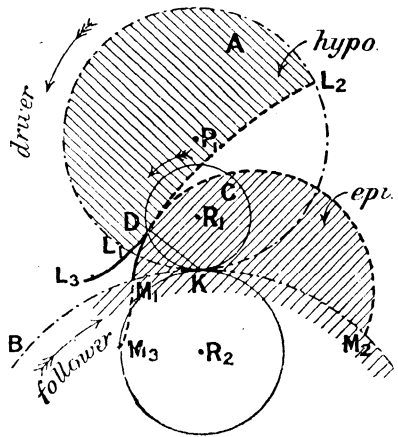

$\cdot P_2$   
FIG. 312.

circles rotate about their respective centres, these will likewise be the curves described by the pencil D on planes attached to A and B.

<sup>1</sup> These curves may be drawn mechanically by making wooden templates of the three circles, and by making C actually roll inside A and outside B; or they may be drawn geometrically as follows: Consider the epicycloid, and take an arc,  $K_1A$  (Fig. 313), of the rolling circle which subtends, say, an angle of  $90^\circ$  at the centre  $R_1$ . Make the angle  $K_1P_2K_2$  such that it is equal to  $90^\circ \times \frac{R_1K_1}{K_1P_2}$ , so that the arc  $K_1K_2$  is quarter the circumference of the rolling circle. With  $P_2$  as centre, draw the arc  $R_1R_2$ , and divide this arc and the arc  $K_1A$  into the same number of equal parts (say four). Draw arcs having centre  $P_2$  to pass through the points of division of the rolling circle; and with the points of division of the arc  $R_1R_2$  as centres and radii equal to the radius of the rolling circle, draw arcs to intersect the circular arcs just drawn. The points of intersection thus obtained are points on the required epicycloid. Since there are two points of intersection corresponding to each centre, care must be exercised in taking the correct one.

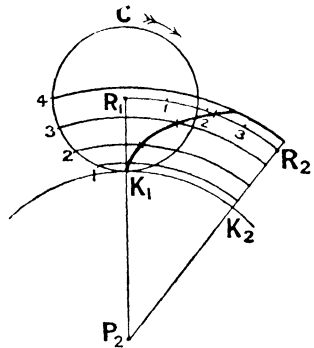

FIG. 313.

The point  $K$  is the instantaneous centre of  $C$  relative to both  $A$  and  $B$  (§ 112), and, therefore, the line  $KD$  is the normal to both curves at the point  $D$ ; consequently, the necessary kinematic condition is satisfied. If plates, cut to the shaded shapes, rotate about the centres  $P_1$  and  $P_2$ , they will transmit the same motion by sliding contact that the pitch circles would by rolling contact; and the amount of sliding will be the difference in the lengths of the arcs  $M_1DM_2$  and  $L_1DL_2$ . In practice, only portions of the curves are used, so that if the acting surfaces of the teeth are  $DL_1$  and  $DM_1$ , and if the upper wheel be the driver, contact will commence at the point  $D$ , as shown, and will cease at the pitch point when  $L_1$  and  $M_1$  coincide. Thus the action is only during approach. The arc  $DL_1$  will represent the *flank* of the driving tooth, and the arc  $DM_1$  the *face* of the driven tooth. Whilst the *path of contact*, that is to say, the locus of the point of contact, will be the circular arc  $DK$  of the rolling circle.

If contact has to take place during recess as well as approach, the teeth of the driver must be provided with faces, and the teeth of the follower with flanks. Both these must be generated by the same circle rolling outside  $A$  and inside  $B$  respectively. The diameter of the second rolling circle is arbitrary, and need not be the same as the diameter of the first rolling circle. Its centre may be  $R_2$ , the epicycloid generated by rolling outside  $A$  being  $L_1L_3$ , and the hypocycloid generated by rolling inside  $B$  being  $M_1M_3$ .

It will thus be seen that the faces of one set of teeth, and the flanks of the other set, are described by the same rolling circle—the face, in external gearing, being epicycloids, and the flanks hypocycloids; but that the rolling circle which describes the face of a tooth need not have the same diameter as that which describes the flank. Precisely the same method may be used for internal gearing, only, in this case, the flank of the tooth of the pinion and the face of the tooth of the annular wheel are both hypocycloids formed by one rolling circle; and the face of the tooth of the pinion and flank of the tooth of the annular wheel are both epicycloids formed by the second rolling circle. These statements are obvious from Fig. 314.

But, besides satisfying the kinematic condition, the forms given

to the teeth must also satisfy the conditions quoted in §176, namely, that the obliquity must not be too great, and that the tooth must not be weak at the root. In *cycloidal teeth*, as they are termed, the path of contact is the circular arc DK (Fig. 312), and the obliquity varies from a maximum at the point where contact commences, to zero at the pitch point. To prevent the pressure on the bearings becoming excessive, the average obliquity ought not to exceed  $15^\circ$ , so that maximum obliquity ought not to exceed  $30^\circ$ .

Again, the diameters of the rolling circles, which need not be the same, are to a considerable extent arbitrary. It is evident from Figs. 315, 316, 317, that the flanks of the teeth will be concave, radial straight lines, or convex according as the diameter of the rolling circle is less than, equal to, or greater than the radius of the corresponding pitch circle; and the sections

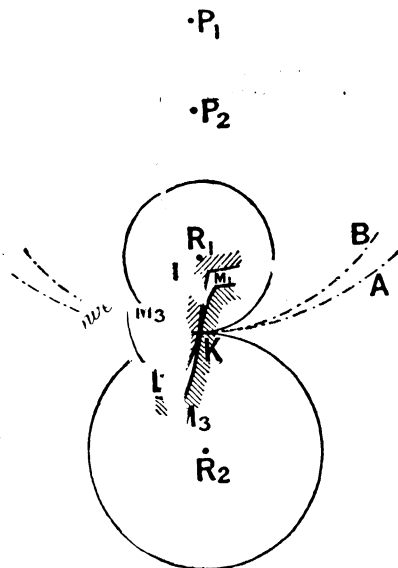

FIG. 314.

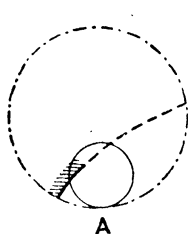

FIG. 315.

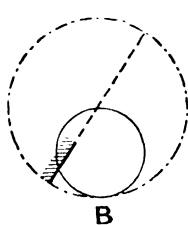

FIG. 316.

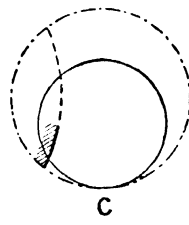

FIG. 317.

of the teeth corresponding to these three cases are shown in development in Fig. 318. It will be noted that in A the tooth is thickest at the root, whilst in C it is thinnest at the root. On

strength considerations, therefore, the diameter of the rolling circle ought not to exceed the radius of the corresponding pitch circle.

Again, if in a set of wheels any two of the set have to mesh with each other, the pitch must be the same in each wheel, and

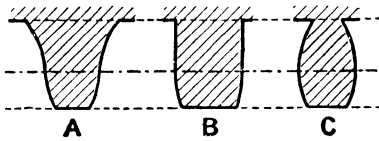

FIG. 318.

also the diameters of the rolling circles which describe the face and flank of every tooth must be the same throughout. This can be seen by considering the teeth of three different wheels,

A, B, and C (Fig. 319). If A mesh with B, the face of A and the flank of B must be described by the same rolling circle of diameter

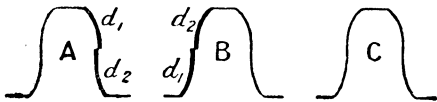

FIG. 319.

$d_1$ , say; and the face of B and the flank of A must be described by a second rolling circle of diameter  $d_2$ , say. If C mesh with A, its

face must be described by a rolling circle of diameter  $d_2$ , and its flank by a rolling circle of diameter  $d_1$ ; whilst if it mesh with B, the rolling circle which describes the face must be of diameter  $d_1$ , and that which describes the flank must be of diameter  $d_2$ . For C to mesh with both A and B,  $d_1$  must clearly be equal to  $d_2$ ; and thus for a number of wheels to mesh together, the same rolling circle must be used throughout. Very frequently the diameter of the rolling circle is made equal to the radius of the smallest pitch circle of the set.

It will be noticed that the distance between the centres of wheels using cycloidal teeth, unlike those using involute teeth, cannot be altered.

The general extension of the method just described of obtaining two suitably shaped profiles is discussed in § 209.

Approximate methods of drawing involute and cycloidal teeth will be found in works on machine design. These methods are not given here, because it is desirable, for smooth working, that the teeth should be as accurately shaped as possible. And it should be remembered that, except when the wheels are cast from a wooden pattern, it is unnecessary to draw in all the teeth. In

machine-moulded wheels two or three teeth only are required; and in machine-cut wheels, the forms of the teeth of the cutter are either generated (§§ 193, 194), or else the template of one tooth only is required (§ 195).

§ 178. **Minimum Number of Teeth in Spur Wheels.**—The least number of teeth which can be used in spur wheels is determined by the lengths of the arcs of approach and recess, and by the maximum obliquity allowed.

In wheels using *cycloidal* teeth, if contact commences at the point D (Fig. 312), the arc of approach is the arc  $KL_1$  or  $KM_1$ , and each of these is equal to the arc  $KD$  of the rolling circle—since the curves  $DL_1$ ,  $DM_1$  are generated by the circle  $C$  rolling, without slipping, inside  $A$  and outside  $B$ . If two pairs of teeth are always in contact, the arcs of approach and recess must each be equal to the pitch (§ 171), and consequently the arc  $KD$  must be equal to the pitch. If, in addition, the maximum obliquity is  $30^\circ$ , the arc  $KD$ , and therefore the pitch, is one-sixth the circumference of the rolling circle. If we consider the smallest wheel of the set, the diameter of the rolling circle must not exceed half the diameter of the pitch circle, so that the pitch ought not to be greater than one-twelfth the circumference of the pitch circle; or, in other words, the number of teeth in the smallest wheel, of the set ought not to be less than twelve. If the arc of approach is made greater than the pitch, or the maximum obliquity less than  $30^\circ$ , or the rolling circle less than half the size of the corresponding pitch circle, the minimum number of teeth which can be used is greater than twelve.

In *involute* teeth, contact cannot possibly commence before the point  $E$  (Fig. 320), since the involute of the base circle of the driving wheel can only commence at that point. Consequently, if, as before, the arc of approach is made equal to the pitch, the pitch

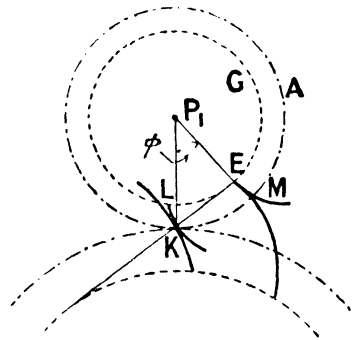

FIG. 320.

cannot be greater than the length of the arc KM, where the curves EM and KL are the involutes to the base circle G. If, therefore, the least number of teeth that can be used is denoted by  $n$ —

$$n \times \text{arc KM} = \text{circumference of pitch circle}$$

and, therefore—

$$n \times \text{arc EL} = \text{circumference of base circle.}$$

But since KL is the involute of the base circle G, the arc EL is equal to EK; hence—

$$n = \frac{\text{circumference of base circle}}{\text{EK}} = \frac{2\pi \cdot P_1E}{KE} = 2\pi \cot \phi$$

where  $\phi$  is the angle of obliquity. If  $\phi$  be taken equal to  $15^\circ$ , the number of involute teeth in a wheel ought not to be less than twenty-four. If the arc of approach be greater than the pitch, or the obliquity less than  $15^\circ$ , the least number can, of course, exceed twenty-four.

§ 179. **Special Cases.**—The preceding principles and constructions are true whatever the relative or absolute sizes of the pitch circles; or, in the case of cycloidal teeth, whatever the sizes of the rolling circles. In particular one of the wheels may be of infinite radius, in which case the wheel becomes a *rack*; or the rolling circle, in the case of cycloidal teeth, may be equal in diameter to the corresponding pitch circle, in which case the hypocycloids forming the flanks of the teeth become points; or, finally, the rolling circle which generates the faces of one set of teeth may be of infinite radius, in which case the epicycloids are of the same shape as the curves generated by a tracing point in a straight line which rolls, without slipping, round a circle; that is to say, they are involutes of circles. These statements are geometrical truths which a moment's thought will render clear. Let us, therefore, consider a few of the more important special cases.

§ 180. **Rack and Pinion.**—The rack is merely a circle of infinite radius. If the teeth be cycloidal, the flanks and faces of the pinion are *hypo-* and *epi-*cycloids respectively; and of the rack *cycloids* (Fig. 321). If the rolling circles are half the respective pitch circles, the flanks of the pinion are *radial straight lines*, and

the faces are epicycloids described by a circle of infinite radius rolling outside the pitch circle of the pinion—that is to say, they are *involute*s. In the rack, the faces are cycloids, and

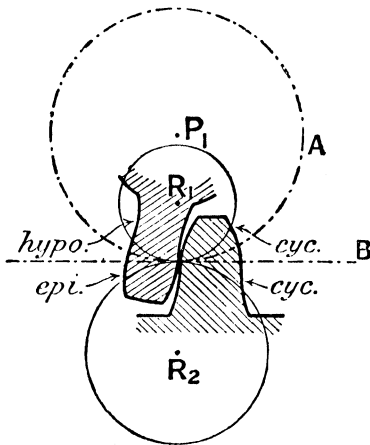

FIG. 321.

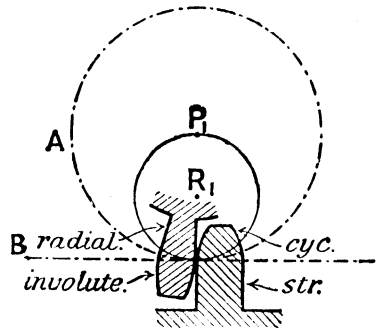

FIG. 322.

the flanks straight lines perpendicular to the pitch line of the rack (Fig. 322).

If the pinion has involute teeth, so also must the rack. The radius of the base circle of the rack is infinite—since its centre is off at infinity—and therefore the teeth of the rack are straight lines inclined, usually, at an angle of  $75^\circ$  with the pitch line of the rack (Fig. 323).

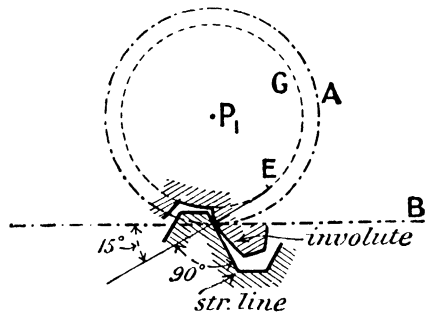

FIG. 323.

§ 181. Pin Wheels.—If the rolling circle be equal in diameter to the pitch

circle, the hypocycloids become points, and the faces of the second wheel become epicycloids formed by the first pitch circle rolling outside the second. In practice, the teeth of the first wheel are circular pins or staves, and the proper shape of the teeth of the second wheel is found by drawing curves parallel to and within

the epicycloids, at a distance from them equal to the radius of the pin (Fig. 324). The number of pins on the pin wheel will

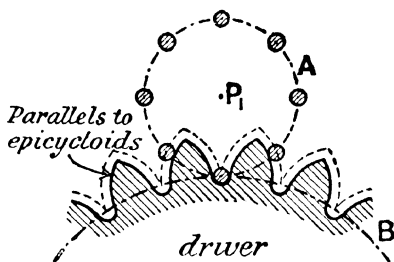

FIG. 324.

depend on the height of the tooth on the second wheel, and the latter in turn will depend on the length of the arc of contact and the maximum obliquity allowed. If the arc of approach or recess be equal to the pitch, and the maximum obliquity be  $30^\circ$  (as in § 177), the number of pins on the pin wheel will be six. More frequently the number of pins is greater than six.

It will be noticed that the teeth have no flanks, and driving contact can only take place during recess or approach. When the teeth drive the pins, contact is during recess, and there is no approach, because the teeth only commence to act on the pins at the pitch point. When the pins drive the teeth, contact only takes place during approach, and there is no recess, since the pins cease to act on the teeth at the pitch point. Kinematically, it is a matter of indifference which is the driver and which the follower, but it may be shown that the frictional losses are less when driving contact takes place during recess than when it takes place during approach; consequently, where the loss of power in friction is an important consideration (as in watch-making), the pins are invariably placed on the follower.

If the pin wheel gear internally with the toothed wheel, the shape of the teeth must be curves parallel to hypocycloids. In particular, if the pitch circle of the pin wheel is half the diameter of the pitch circle of the toothed wheel, the hypocycloids become radial straight lines. The arrangement, therefore, may be as shown in Fig. 325, in which the pin wheel has three teeth, and the surfaces of the teeth of the wheel form three straight radial grooves of width equal to the diameter of the pins. If the pin wheel have four teeth, the radiating grooves must be inclined at  $45^\circ$  instead of  $60^\circ$ .

In order to reduce the sliding friction between the teeth and the staves of the pin wheel, the latter may be replaced by rollers which rotate on studs attached to the rim of the pin wheel. The contact between the teeth and the rollers is then one of rolling.

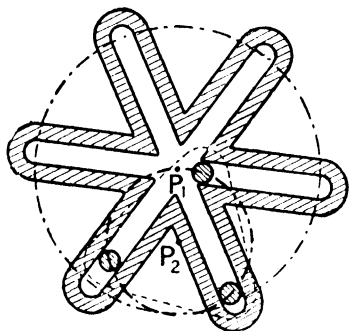

FIG. 325.

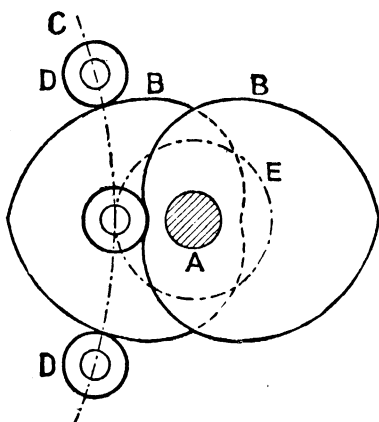
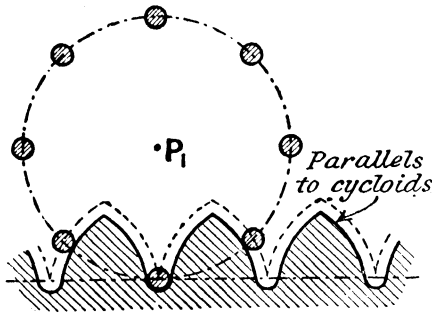

FIG. 326.

§ 182. *Grisson Gear*.—An interesting application of pin wheels is the *Grisson gear*, illustrated in Fig. 326, and which is used where great reduction in speed between two parallel shafts is required; as, for example, in electrical motors and motors for motor-cars. On the high-speed shaft A are keyed two curved plates or cams, B, B, exactly similar in shape, but set directly opposite to each other. These are placed side by side, and gear with a large pin wheel, C, which has two roller paths, D, D, so that one of the cams B, B is always in contact with a roller carried on pins fixed near the rim of the wheel. Each curved plate is made symmetrical, so that motion may take place equally well in both directions, and there is no back-lash. The shape of the cams must be parallel curves to epicycloids—the epicycloids being formed by the larger wheel C rolling outside the pitch circle of the smaller wheel, namely, the circle E in Fig. 326. By increasing the diameter of the roller wheel and introducing a larger

be obtained in a compact form; and as the contact between the cams and rollers is a perfect rolling one, the mechanical efficiency is high. The rolling parts are made of the very hardest steel, so that but little wear takes place. It may be used either for speeding up or down.

§ 183. **Pin Wheel and Rack: Wheel and Pin Rack.**—If the pins be on the wheel, the faces of the rack are parallel curves



*driver*  
FIG. 327.

to cycloids, the cycloids being formed by the pitch circle of the pin wheel rolling on the pitch line of the rack. For driving contact to take place during recess, the rack must drive the pin wheel (Fig. 327).

If the pins be on the rack, the corresponding rolling circle is of infinite radius, and the faces of the pinion are parallel curves to involutes of the pitch circle,<sup>1</sup> since the involute is the curve traced out by

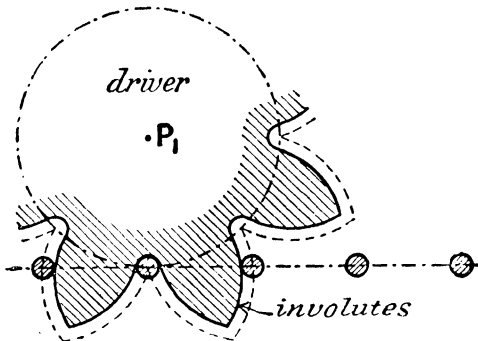

FIG 328.

a point in the pitch line of the rack as it rolls outside the pitch circle of the pinion. For contact to take place during recess, the pinion must drive the rack (Fig. 328).

<sup>1</sup> The parallel curve to an involute is itself an involute of the same base circle.

§ 184. **Chain Wheels.**—In chain wheels, such as are shown in Figs. 329, 330, the pitch line of the wheel is a polygon. The sides of the polygon may be all equal, as in Fig. 329, or it may have long and short sides alternately, as in Fig. 330. In Fig. 329

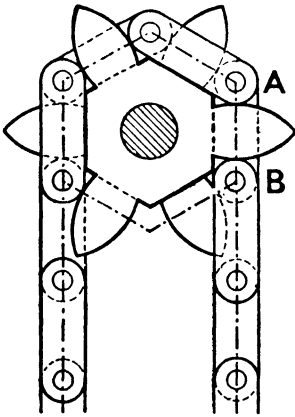

FIG. 329.

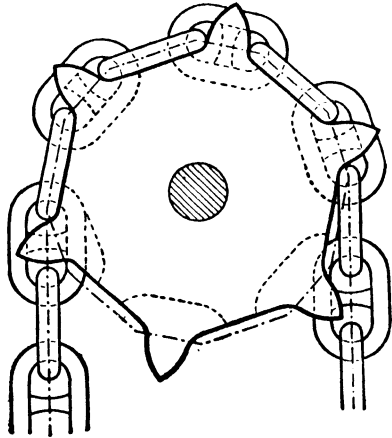

FIG. 330.

the chain consists of double and single links—the double links lying one on each side of a single tooth, and the single link lying between a double tooth of the chain wheel. In Fig. 330 each short side only of the polygon is provided with a pair of teeth—the link standing edgewise between them, and the ends of the link which lies flatwise pressing against the teeth.

The shape of the teeth may be found by proceeding as before, namely, by imagining the wheel to be fixed and the chain to be unwrapped. Any link, such as AB (Fig. 329), will turn about the centre of the pin A, and therefore the centre B will describe a circular arc. The shape of the tooth will likewise be a circular arc of centre A, and of radius equal to the length of the link less the radius of the pin. In order to reduce the sliding friction between the pins and the teeth, the teeth, as before, may act on rollers which turn on pins.

In practice the pitch of the chain, that is to say, the distance between the pins, increases with time for two reasons; namely, on

account of the actual stretching of the chain, but chiefly on account of the wearing of the pins. The result is, if the chain has the proper pitch to start with, after a certain time it fails to accurately "bed" on the wheel or mesh with the teeth. The wear can be very much reduced by proper design and choice of materials, but it can never be altogether eliminated. Very frequently, the initial pitch of the chain is made purposely less than the pitch of the

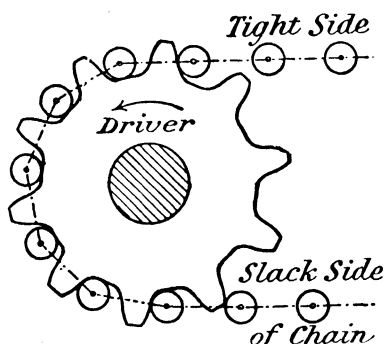

FIG. 331.

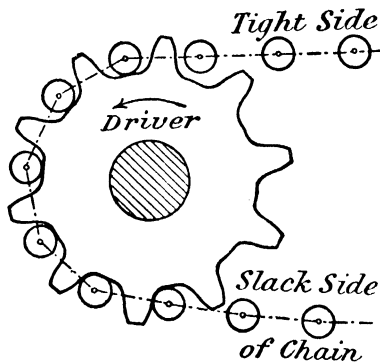

FIG. 332

wheel, and the pins have a considerable back-lash in the spaces between the teeth; the result is that, at any instant, all the force

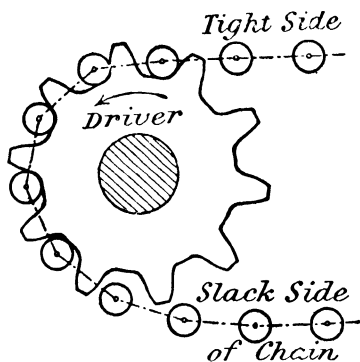

FIG. 333.

comes on one pin, namely, upon the pin which receives or delivers the slack side of the chain (see Fig. 331). As the chain stretches or the pins wear, the pitch gets more nearly equal to the pitch of the wheel (Fig. 332), and at some particular instant, each pin is driving equally. As the pitch of the chain still further increases, the whole driving force again, at any instant, comes on one pin; namely, on the pin which receives

or delivers the tight side of the chain (Fig. 333). If the stretch is considerable, the pins will not bed in the hollows between the

teeth, and the chain then works very unsteadily and with considerable noise. It is for this reason that in some cases the wheel is only provided with two teeth placed at opposite extremities of a diameter.

§ 185. **Renold's Chain Gearing.**<sup>1</sup>—An entirely different type of chain, designed so that the chain accurately gears with the wheel even when the chain stretches a considerable amount, is shown in Fig. 334. The usual links are replaced by thin plates of claw-shape, the teeth of the wheel having practically straight-line flanks and faces. When new, the edge of one of the claws is in contact with the

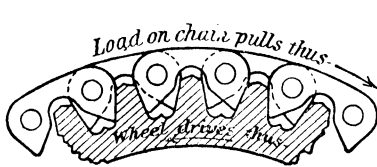

FIG. 334.

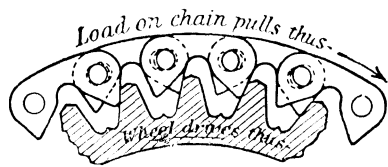

FIG. 336.

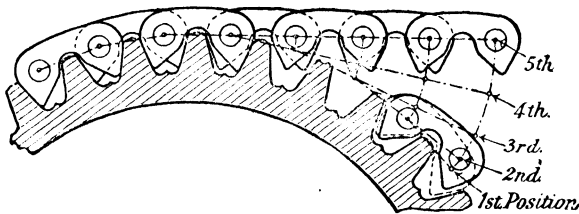

FIG. 335.

front side of a tooth, and the edge of the other claw practically in contact with the back side of an adjacent tooth, and there is very little, if any, back-lash. The relative positions of the teeth and claws as they come into gear is shown in Fig. 335, in which the wheel is supposed fixed and the chain wrapped round it. When the pins of the chain wear, the chain slides nearer the points of the teeth, as shown in Fig. 336, but the two still gear correctly even if the wear of the pins is not the same. There is then, of course, considerable back-lash, but the chain runs perfectly steadily and with little noise.

<sup>1</sup> See a paper by Mr. Garrard on "Some recent Developments in Chain Driving."

§ 186. Relation between the Height of a Tooth and the Arc of Approach or Recess, in Involute and Cycloidal Teeth. Geometrical and Analytical Solutions.—It has been pointed out that the arc of approach depends on the addendum of the follower, and the arc of recess on the addendum of the driver. If the arcs of approach and recess be given, the addendum circles may be found, either graphically or analytically, in the following manner.

First consider *involute teeth*. If contact commences at the point D, the length of the arc of approach is the length of either of the arcs KM, KL (Fig. 337), the points M and L being the

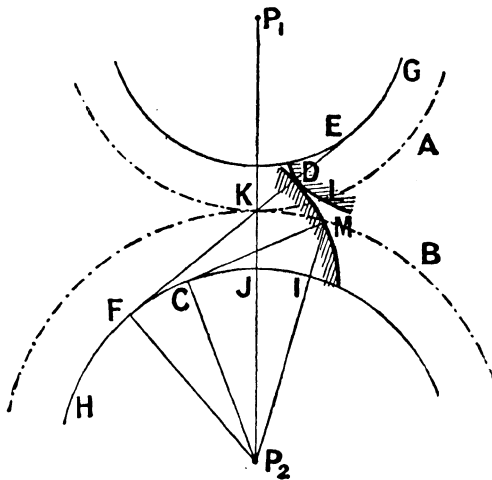

FIG. 337.

points where the profiles cut the respective pitch circles. The profile DM is the involute to the base circle H, and therefore, if MC is the tangent to this circle, the arc FC together with CM must be equal in length to FD; and since FK is equal to CM (each being the length of a tangent to the base circle bounded by the pitch circle), it follows that the length KD is equal to the length of the arc FC. But the triangles  $P_2FK$  and  $P_2CM$  are equal in all respects, so that the arcs JI and FC are equal; hence the arc JI is equal to KD. To find, then, the addendum circle of the follower when the arc of approach is given, mark off (Fig. 338)

the arc KM on the pitch circle of the follower equal to the given arc of approach, and join  $P_2M$  to meet the base circle of the follower in I; along the path of contact EF, mark off the distance KD equal to the arc  $JI$ .<sup>1</sup> The circle through D, having  $P_2$  as centre, is the addendum circle of the follower. In a similar manner, the addendum circle of the driver may be obtained when the arc of recess is given. Sufficient clearance must be allowed between the addendum circle of one wheel and the root circle of the other.

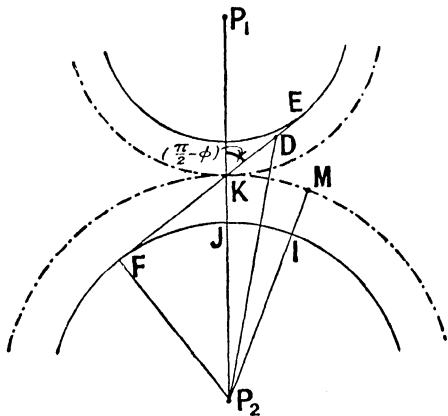

FIG. 338.

To express the relationship analytically, let  $\alpha$  be the arc of approach,  $r_1$  and  $r_2$  the radii of the two pitch circles, and  $h_2$  the addendum of the follower, so that  $r_2 + h_2$  is the radius of the addendum circle of the follower, and is therefore equal to  $P_2D$  (Fig. 338). Then since—

$$P_2D^2 = KP_2^2 + KD^2 - 2KP_2 \cdot KD \cos \angle DKP_2$$

<sup>1</sup> The following approximate construction may be used to measure off, along a circle, an arc of given length: At the point A (Fig. 339) draw a tangent, AB, equal to the given length, and in AB take AC such that  $AC = \frac{1}{4}AB$ . With C as centre, draw the circular arc BD to meet the given circle in D: then AD is the required arc.

To draw a line approximately equal to a given circular arc, AB (Fig. 340),

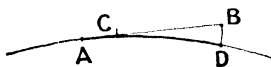

FIG. 339.



FIG. 340.

join BA and produce it to C, so that  $AC = \frac{1}{4}$  the chord AB. At A draw a tangent to the given circle to meet a circle of centre C and radius CB in D. The length of the arc is very approximately equal to the length AD.

we have—

$$(h_2 + r_2)^2 = r_2^2 + KD^2 - 2r_2 \cdot KD \cos \left( \frac{\pi}{2} + \phi \right)$$

where  $\phi$  is the angle of obliquity of the line of action. Also, since KD is equal to the arc JI—

$$\frac{KD}{\text{arc KM}} = \frac{JP_2}{KP_2} = \frac{FP_2}{KP_2} = \cos \phi$$

therefore—

$$KD = a \cos \phi ;$$

whence, substituting and expanding—

$$h_2^2 + 2h_2r_2 = a^2 \cos^2 \phi + 2ar_2 \sin \phi \cos \phi$$

Usually  $h_2$  is very small compared to  $r_2$ , and therefore  $h_2^2$  may be neglected compared to  $2h_2r_2$ ; whence—

$$h_2 = \frac{a \cos \phi}{2} \left( \frac{a}{r_2} \cos \phi + 2 \sin \phi \right)$$

If  $n_2$  is the number of teeth in the follower, and  $p$  the pitch—

$$2\pi r_2 = n_2 p$$

and the expression for  $h_2$  becomes—

$$h_2 = \frac{1}{2} a \cos \phi \left( \frac{2\pi a}{n_2 p} \cos \phi + 2 \sin \phi \right)$$

Taking  $\phi$  to be  $15^\circ$ , we get, very approximately—

$$h_2 = a \left( \frac{3a}{n_2 p} + \frac{1}{4} \right)$$

which enables  $h_2$  to be calculated when the arc of approach, the pitch, and the number of teeth in the follower are given. The most usual proportion is to make (Fig. 299)  $h_2 = 0.3p$ , in which case the equation becomes—

$$\frac{0.3p}{a} = \frac{3}{n_2} \cdot \frac{a}{p} + \frac{1}{4}$$

whence, solving—

$$\frac{a}{p} = \frac{n_2}{24} \left( \sqrt{1 + \frac{57.6}{n_2}} - 1 \right)$$

The value of  $\frac{a}{p}$  is greater, therefore, the greater the number of teeth. The least number of involute teeth is usually 24, which would make  $\frac{a}{p} = 0.846$ . For very large values of  $n_2$ , the expression may be written—

$$\frac{a}{p} = \frac{n_2}{24} \left\{ \left( 1 + \frac{28.8}{n_2} \right) - 1 \right\} = 1.2$$

Thus, with the usual proportions, the total arc of contact with involute teeth varies from 1.7 to 2.4 times the pitch.

The general formula for the addendum of the driver is—

$$h_1 = \frac{1}{2}b \cos \phi \left( \frac{2\pi b}{n_1 p} \cos \phi + \sin \phi \right)$$

in which  $b$  is the arc of recess, and  $n_1$  the number of teeth in the driver.

Next, consider *cycloidal teeth*. If contact commence at the point D (Fig. 341), the arc of approach is either KL or KM, the points L and M being the points where the profiles of the teeth cut the respective pitch circles. Now, either of these arcs is equal to the arc KD of the rolling circles, so that if KD is made equal to the arc of approach, the addendum circle of the follower passes through D.

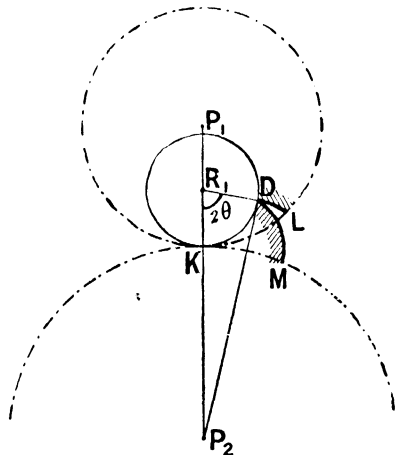

FIG. 341.

To obtain an analytical expression, let the same symbols be used as in the previous case, and, in addition, let  $r_2'$  be

the radius of the rolling circle which describes the face of the follower—that is to say, the radius of the circle of centre  $R_1$ ; and let the angle which the arc  $KD$  subtends at the centre  $R_1$  be  $2\theta$ . Then—

$$P_2D^2 = P_2R_1^2 + R_1D^2 - 2P_2R_1 \cdot R_1D \cos 2\theta$$

$$\text{or } (r_2 + h_2)^2 = (r_2 + r'_2)^2 + r_2'^2 - 2r'_2 (r_2 + r'_2) \cos 2\theta$$

Expanding and neglecting  $h_2^2$ —

$$h_2r_2 = r'_2 (r_2 + r'_2) (1 - \cos 2\theta)$$

$$= 2r'_2 (r_2 + r'_2) \sin^2 \theta$$

Usually the value of  $\theta$  is sufficiently small to justify us in neglecting  $\theta^3$  compared to  $\theta$ , in which case the expression becomes—

$$h_2r_2 = 2r'_2 (r_2 + r'_2)\theta^2$$

But—

$$\text{arc } KD = a = r'_2 \cdot 2\theta$$

whence by substitution—

$$h_2 = \frac{a^2}{2} \left( \frac{1}{r'_2} + \frac{1}{r_2} \right)$$

The value of  $r'_2$  is arbitrary within wide limits. The greater  $r'_2$ , the less the addendum for a given arc of approach, or the greater the arc of approach for a given addendum. The greatest value of  $r'_2$  is usually (§ 177) half the radius of the pitch circle of the driving wheel, and is therefore  $\frac{r_1}{2}$ . Using this value, we get—

$$h_2 = \frac{a^2}{2} \left( \frac{2}{r_1} + \frac{1}{r_2} \right)$$

$$= \frac{\pi a^2}{p} \left( \frac{2}{n_1} + \frac{1}{n_2} \right)$$

where  $n_1, n_2$  are the number of teeth in the driving and following wheels respectively, and  $p$  is the pitch. Taking the usual proportion, namely,  $h_2 = 0.3p$ , we have—

$$\frac{a}{p} = \frac{0.31}{\sqrt{\frac{2}{n_1} + \frac{1}{n_2}}}$$

The smaller  $n_1$  and  $n_2$ , the smaller  $\frac{a}{p}$ . Usually the least number of cycloidal teeth is 12, so that, assuming that there are 12 teeth in each wheel, the value of  $\frac{a}{p}$  becomes 0.62. If  $n_1$  is equal to 12, and  $n_2$  is very large,  $\frac{a}{p} = 0.76$ ; and if  $n_1$  is very large, and  $n_2$  equal to 12,  $\frac{a}{p} = 1.07$ . If the rolling circle is less than half the size of the corresponding pitch circles, these values would have to be decreased; but ordinarily, we may say that the total arc of contact in cycloidal teeth is not greater than  $1\frac{1}{2}$  to 2 times the pitch. With the same addendum, the arc of contact will, in general, be less in cycloidal than in involute teeth.

The general formula for the addendum of the driver is—

$$h_1 = \frac{b^2}{2} \left( \frac{1}{r_1'} + \frac{1}{r_1} \right)$$

in which  $b$  is the arc of recess, and  $r_1'$  the radius of the rolling circle which traces out the face of the tooth of the driver.

§ 187. **Stepped Wheels. Helical Gearing.**—It has just been shown that, taking the usual proportions of teeth, the arc of contact varies from  $1\frac{3}{4}$  to  $2\frac{1}{2}$  times the pitch in involute teeth, and from  $1\frac{1}{4}$  to 2 times the pitch in cycloidal teeth. The greater the number of teeth in contact at the same time, the smoother will be the action between the teeth. This follows from the fact that the larger the number of teeth in contact at the same time, the less, in cycloidal teeth at least, will be the average obliquity of the line of pressure between the wheels. Thus, for example, if two pairs of teeth are always in contact at the same time, one pair of teeth are just coming into gear when the preceding pair are in contact at the pitch point. The pressure between the pair just coming into gear will, neglecting friction and assuming the ordinary obliquity, act at an angle of  $60^\circ$ , about, with the line of centres. If there are more pairs than two in contact at the same time, the total force will be distributed between the teeth, and the angle of obliquity will vary from  $0^\circ$ ,

through various angles, to a maximum of  $30^\circ$ . Thus the average tangential force will be increased and will also be more uniform, whilst the component of the forces acting along the line of centres will be reduced, and, therefore, so also will the frictional resistance on the journals.

This argument hardly applies to involute teeth, because the obliquity, and therefore, neglecting friction, the line of action of the force between two teeth, is always constant. But there is a further advantage which applies equally to cycloidal as to involute teeth. The velocity of sliding, at any instant, is proportional to the length of the normal to the profiles of the teeth measured to the pitch point. By having a large number of teeth in contact at the same time, the average length of this normal is reduced, and so, therefore, is the average velocity of sliding. Thus the work spent in overcoming the friction due to the sliding of the teeth is reduced and made more uniform.

The number of teeth in contact at a given time may be increased in two ways. *First*, by reducing the pitch, and therefore the thickness of the tooth, the arc of contact being kept the same. Reducing the pitch will increase the number of teeth in the wheel but will not alter the product of the pitch and the number of teeth, and therefore (see the expressions for  $h_2$  in the previous article) will not alter the addendum. It will also reduce the pressure acting between any pair of teeth, since the number of pairs in contact is increased; and it will weaken the teeth on account of their reduced thickness. The tooth acts as a cantilever, and it may be readily shown that the tooth is weakened in a greater ratio than the pressure acting on it is reduced, with the result that the effect of reducing the pitch is to make the tooth weaker to withstand the forces acting on it. *Second*, keeping the pitch the same, the height of the tooth may be increased, and the effect will be to increase the arc of contact, and therefore the number of teeth in contact at the same time. But, as is evident from the formulæ for  $h_2$  in the previous article, the arc of contact is not increased at the same rate as the height of the tooth; or, in other words, the force acting between any pair of teeth is not reduced in the same ratio as the height

of the tooth is increased, and consequently the tooth is again weakened.

It is evident, therefore, that the number of teeth in contact at a given time can only be increased by sacrificing the strength of the tooth. But the required purpose may be attained without sacrifice of strength by using what are termed *stepped wheels*. A stepped wheel resembles a number of equal and similar toothed wheels placed side by side, the teeth of each being set a little behind the preceding one, as shown in Fig. 342. With the same proportions as in ordinary wheels, the number of teeth in contact at one time is increased in the same proportion as the number of steps without any sacrifice of strength, since the pressure per unit length of tooth remains unaltered. The number of steps is arbitrary, and, for convenience, the wheels may be set at equal distances behind each other. If the steps are made very small indeed, the stepped teeth may be replaced by a single tooth whose centre line is a true helical curve traced on the pitch cylinder of the wheel, as shown in Fig. 343. The obliquity of the helices

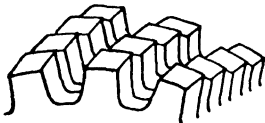

FIG. 342.

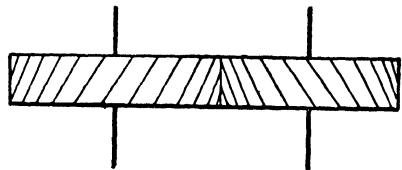

FIG. 343.

of the two wheels must be the same in each, and (in external gearing) in opposite directions; and the breadth of the rim, in relation to the obliquity of the helix, ought to be such that the contact of one pair of teeth does not terminate before that of the next pair commences. Such wheels are called *helical wheels*, and with them the contact of each pair of teeth commences at the foremost end of the helical fronts and terminates at the aftermost end.

An objection to the use of helical wheels is that the pressure between the teeth is perpendicular to the line of the helix, and, therefore, in addition to having a circumferential

force causing rotation, there is an axial component tending to separate the wheels and producing end thrusts on the supports.

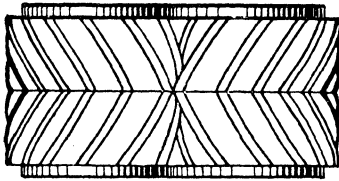

FIG. 344.

To overcome this difficulty, a *double helical wheel* is frequently used (Fig. 344), the obliquity of the helices being the same. So long as the central planes of the two wheels coincide, the side thrusts of the two helices neutralize. Wheels of this kind are

used in machinery where smooth, regular, and noiseless motion is important.

As regards the strength of helical wheels compared with ordinary spur wheels, the normal pressure on the teeth (acting perpendicularly to the direction of the helix) is greater than the circumferential force in the proportion of the length of the tooth to the width of the face of the wheel, so that, for that reason alone, the strength would be the same in each, since the force per unit length would be the same. But with helical gearing, the average leverage at which the force on the tooth acts is less than with ordinary gearing. In ordinary gearing, the whole force may act at the edge, in which case the leverage will be the height of the tooth; in helical gearing, the leverage varies along the length of the tooth from (practically) zero to the full height of the tooth, so that the average leverage is much less in helical than in ordinary spur gearing.<sup>1</sup> Thus helical teeth are stronger than spur gearing.

§ 188. **Teeth of Bevel Wheels.**—In all the preceding work the axes have been assumed parallel, in which case the pitch surfaces are cylinders. If the axes are not parallel, but intersect, the motion, as already pointed out in § 32, can be transmitted from one to the other by the rolling contact of two circular cones whose axes are coincident with the axes of rotation; and the angular velocity-ratio will be constant. If the angle between the axes and the velocity-ratio are known, the angles of the cones are determined by the construction given in Fig. 48. Moreover, just as in spur wheels, if the force transmitted is great, the frusta of the

<sup>1</sup> Unwin's "Machine Design," pt. i. § 226.

cones must be replaced by projections or teeth, so that the motion is transmitted by the direct action of the teeth.

In bevel wheels, the pitch surfaces are frusta of two cones, and the pitch lines are circles formed by the intersection of the pitch surfaces with a surface perpendicular to it and the axis (§ 35); that is to say, with a sphere having the common vertex of the cones as centres. The pitch circles are conventionally taken as the larger circles of the frusta. When, therefore, the rolling frusta are replaced by teeth, the trace of the teeth on the spherical surface corresponding to the larger circle of the frusta ought to be considered; and the acting surfaces of the teeth may be then imagined generated by the motion of a line which always passes through the point of intersection of the conical pitch surfaces whilst a point in it is carried round the trace. In point of fact, if the pitch cones be imagined made of a soft material like butter, and the line replaced by a thin rod, such as a knitting-needle, the needle would cut out in the butter the proper shape of teeth. The section of the tooth constantly diminishes towards the apex of the cone; a perspective view is shown in Fig. 356.

§ 189. **Formation of Teeth Profiles of Bevel Wheels.**—If the spherical trace of a tooth on one of the wheels is given, the corresponding trace of a tooth on the other wheel to mesh with it is determined by the principles already laid down in § 172, with the exception that all the operations are to be performed on the surface of a sphere instead of on a plane. In practice, however, the traces of the teeth are invariably taken on conical instead of on spherical surfaces. The resulting tooth is not theoretically accurate, but it is generally sufficiently so for practical purposes.

Thus, suppose (Fig. 345) that the point of intersection of the axes is  $O$ , the line of contact of the cones being  $OC$ . Through  $C$  draw the line  $DE$  perpendicularly to  $OC$ , and imagine the rims of the wheels to be portions of the cones  $DCF$  and  $ECG$  (strictly they ought to be portions of a spherical surface passing through  $C$  and having  $O$  as centre). Imagine these cones, of vertices  $D$  and  $E$ , to be cut along a generating line and laid flat, so that the circles whose projections are represented by  $CF$  and  $CG$  become, when

developed, the circles CH and CJ, which have D and E respectively as centres. Design the traces of the teeth for the developed arcs

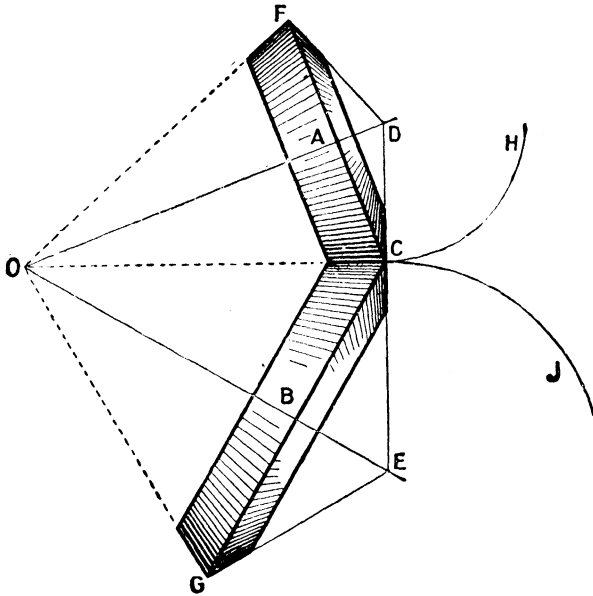

FIG. 345.

CH, CJ in exactly the same way as for spur wheels, treating these arcs as if they were the pitch circles; and, having plotted

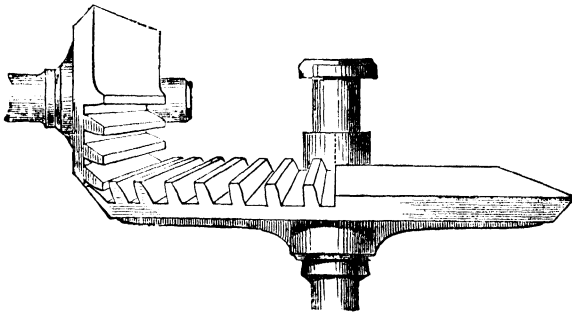

FIG. 346.

them imagine the circles CH, CJ again wrapped on their respective



teeth are involute teeth, the teeth of the rack will be straight lines. For the arc CJ they will be involutes of circles (§ 180).

A machine for cutting bevel wheels, in which the above relationship is made use of, is described in § 194.

**§ 191. Skew-bevel Wheels. Worm and Worm Wheel.**—If the axes of rotation are neither parallel nor intersect, a constant angular velocity may be transmitted between them provided the pitch surfaces are rolling hyperboloids (§ 36). Such surfaces will always touch along a straight line; and, in addition to the rolling motion, there will be a relative sliding motion along the line of contact. For actual wheels, frusta only of the hyperboloids are used; and where extreme accuracy of form is not required, the frusta may be replaced by tangent cones. If the frusta are taken at the “throats” of the hyperboloids, they may be approximately replaced by cylinders, in which case the pitch surfaces will touch at a point instead of along a straight line.

It is not proposed to discuss the general case of skew-bevel wheels. Reference may be made to Rankine’s “Machinery and Millwork,” or to works on Design. But it may be pointed out that just as the teeth of spur wheels may be generated by an auxiliary cylinder rolling outside and inside the respective pitch cylinders, so in skew-bevel wheels, the surfaces of the teeth may be imagined generated by an auxiliary hyperboloidal roller which rolls and slides outside and inside the respective hyperboloidal pitch surfaces—the obliquity of the generating lines of all the hyperboloids being the same, and the generating lines of the rolling hyperboloid tracing out the surfaces of the teeth.

The most important case, in practice, of non-intersecting axes is when the two axes are perpendicular to each other (§ 37). The true pitch surfaces ought to be hyperboloids, but they are generally taken to be cylinders. These surfaces must be provided with teeth, and a section by a plane perpendicular to the axis of the larger wheel (or worm wheel), and containing the axis of the smaller wheel (or screw), has been already shown in Fig. 55. The trace of the pitch cylinder of the worm wheel is a circle, and the trace of the pitch cylinder of the screw is a straight line, the pitch point being the point where they touch. The traces of

the teeth of the worm wheel are like those of a spur wheel having the same pitch circle; those of the threads of the screw are like the teeth of a rack. If involute teeth are employed, the sections of threads of the screw are straight lines, and of the teeth of the worm wheel involutes of circles (§ 180). But, as in ordinary spur gearing, the shape of the thread may be arbitrary; if it is given, then the shape of the tooth of the worm wheel is governed by the principles laid down in §§ 172, 173.

A machine for cutting the teeth of worm wheels is described in § 196.

**§ 192. Machines for cutting Teeth.**—In order to ensure a true constant-velocity ratio, the tooth profiles must be related according to the principles already given. Any two arbitrary curves will transmit a motion of rotation between two axes, but, unless the necessary conditions are satisfied, the velocity ratio will not be strictly constant. This in itself is, perhaps, no great objection; but it is liable to the objection, especially in heavy and fast-running machinery, that the unsteadiness which results causes great noise. In addition, teeth made from a pattern, or machine-moulded teeth, frequently have point contact instead of line contact. It is for these reasons, and also because a machined tooth has a much better finish, that toothed wheels are usually machine cut instead of being cast from a pattern or machine moulded.

Machines for cutting teeth are of various kinds. Very frequently, the teeth are cut by means of a rotating milling tool, but as these are not theoretically accurate, they will not be discussed. The machines that it is proposed to describe may be divided into two types: (1) those in which the profiles are actually generated, as in the Fellows spur-gear shaper (§ 193), the Bilgram bevel-gear shaper (§ 194), and the Gibson worm-wheel gear shaper (§ 196); (2) those in which a template is used to cut the teeth, as in the Gibson bevel-gear shaper (§ 195).

**§ 193. Fellows Spur-gear Shaper.**—The mechanical principle involved in this machine is identical with that already described in § 173. The shape of the teeth of one of the wheels is supposed given, and these act as cutters to cut teeth from a blank which will accurately mesh with the teeth of the first wheel. This is effected in

the following manner:<sup>1</sup> The cutter wheel A (Fig. 348) and the blank B are attached to vertical axes,  $P_1$  and  $P_2$ , and these axes are connected by gearing, so that if rotation takes place, the angular motion of A and B is exactly the same as if their pitch surfaces rolled on each other. In addition, the spindle carrying the cutter can reciprocate in a vertical direction along its axis, and, when ascending, the teeth of A act as cutting tools to the blank B, in the same way as the cutting tool in a planing or shaping machine. Moreover, the spindle of A is carried by a saddle which can be moved along a cross-rail (as in a radial drilling machine or a planing machine), the direction of the cross-rail being parallel to

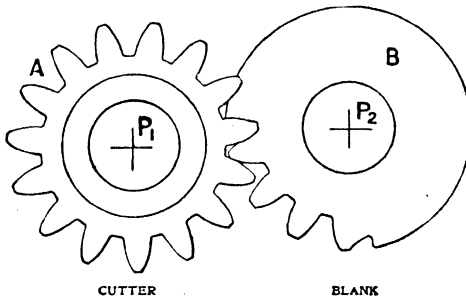

FIG. 348.

the line of centres  $P_1P_2$ , so that  $P_1$  can be made to approach  $P_2$ . The action of the machine is as follows: The cutter and the blank are keyed to their respective axes, and A is given its vertical reciprocating motion, neither cutter nor blank rotating. On the upstroke, the teeth of the cutter cut out metal in the blank, and in each downstroke, the saddle carrying  $P_1$  is fed slightly towards  $P_2$ —in the same way that the tool box in a planing machine is fed across the work (§ 76) during the return stroke of the table. This feeding motion is continued until the centres  $P_1$  and  $P_2$  are at the proper distance apart, and is then discontinued. In place of it, during the down or non-cutting stroke of the cutter, both cutter and blank are turned through small corresponding angles by the gearing already mentioned; during the up or cutting stroke, the

<sup>1</sup> For a description of this machine, the writer is indebted to Mr. Henry Kelly, of Manchester, representative of the Fellows gear shaper in Great Britain.

teeth of the cutter shave off strips of metal from the blank, and neither the cutter nor blank rotate. Thus, the rotation of the cutter and blank is intermittent, and takes place on the down-stroke of the cutter; when cutting, the blank is fixed and the cutter simply ascends. By these means the cutter behaves to the blank in exactly the same manner as is illustrated in Fig. 302; and after one complete rotation of the blank, the teeth are properly shaped on the latter. Fig. 348 shows a blank only part of which has been shaped. Each tooth of the cutter acts as cutting tool in turn, although several teeth may be in operation at the same time; a pair of cutters of different pitch are shown in Fig. 349.

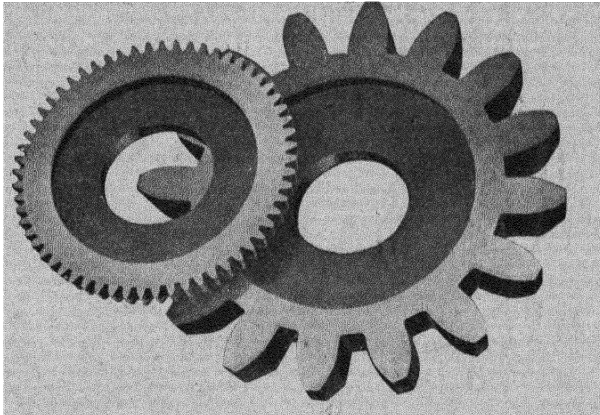

FIG. 349.

A detailed description of the mechanical arrangements of the machine is, perhaps, unnecessary.<sup>1</sup> A general view of the machine is shown in Fig. 350, and a section of the cutter and blank in Fig. 351. The cutter is shown at A, the blank (with the teeth cut) at B. The cutter spindle is carried by the saddle C, which can be placed in any required position on the cross-rails E in the usual way. The mechanism of the saddle serves a similar purpose to the feed mechanism of a drilling machine, or of a horizontal boring machine. The spindle F carries a pinion which meshes with a rack attached

<sup>1</sup> A more detailed account than is here possible will be found in the *Mechanical Engineer* for August 18, 1900.

to a ram or slide, G, enveloping the cutter spindle, the slide being prevented from rotating, but capable of reciprocation in the saddle C. The spindle H carries a worm which meshes with a worm wheel attached to the cutter spindle by a feather key; so that although the cutter spindle reciprocates with the cutter slide, it

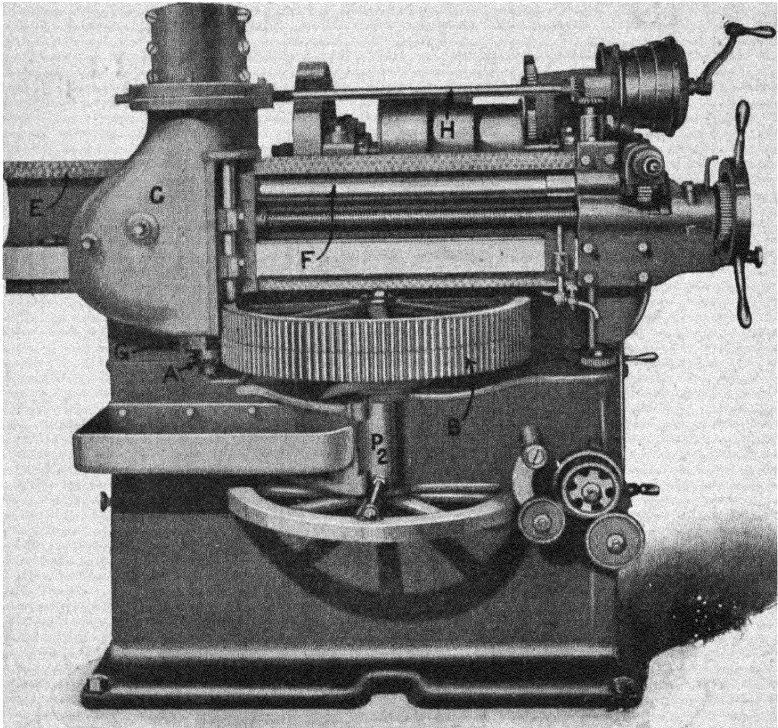

FIG. 350.

can rotate in it. The spindle H and the arbor P<sub>2</sub>, to which the blank is attached, are connected by gearing, so that the motions of rotation of the cutter A and blank B are exactly the same as if their pitch circles rolled on each other. These motions, as already explained, are intermittent, and only take place on the down or non-cutting stroke of the cutter slide. This intermittent

motion is brought about by ratchets driven from the driving shaft in the manner described in § 74. The spindle **F** continually oscillates through a certain angle and causes the reciprocating motion of the cutter slide. During the downstroke of the cutter slide, the blank is released from contact with the cutter by linkwork, which it is not necessary to describe.

The shape of the teeth on the cutter is, theoretically, arbitrary, but they must satisfy the conditions already laid down. In addition, it is desirable that all gears cut by the same cutter should

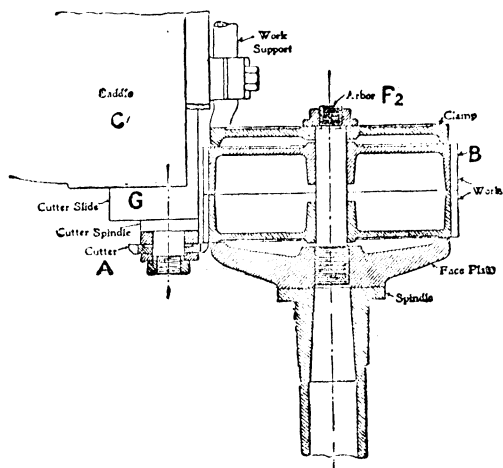

FIG. 351.

mesh together, so that only one cutter is required for each pitch. This condition is satisfied for all involute teeth which have the same obliquity (§ 176), and for all cycloidal teeth in which the faces and flanks are generated by the same rolling circle (§ 177). An objection to cycloidal teeth is, that the teeth of the cutter must likewise be cycloidal, and these can only be produced by means of templates; if the teeth be involutes, so likewise are the teeth of the cutter, and these can be actually generated, not copied, in the following way.

It has been pointed out (§ 180) that when a rack meshes with a pinion having involute teeth, the teeth of the rack are straight lines. Such a rack-tooth profile can be easily originated with

absolute accuracy,<sup>1</sup> and it is from such a rack that the cutters are generated. The cutters, illustrated in Fig. 349, are supplied by the makers of the machine, and are an integral part of the equipment. Fig. 352 shows how the cutters are generated from a rack profile.

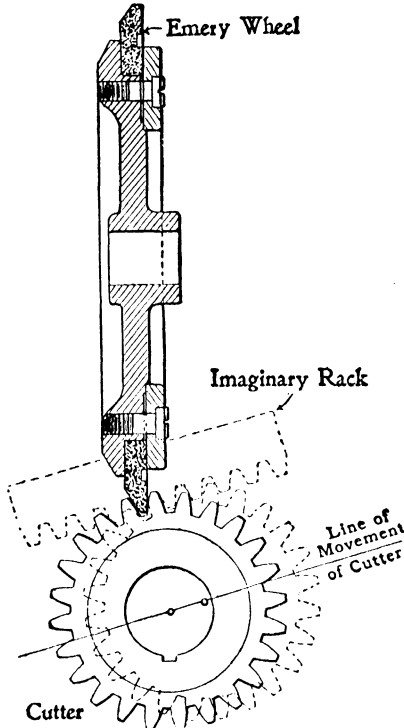

FIG. 352.

The emery wheel represents one side of an imaginary rack tooth, the complete imaginary rack being shown by dotted lines. The flat face of this wheel is dressed off to positive accuracy by a mechanically guided diamond tool. The cutter—previously roughed out and hardened—is rolled past the emery wheel in true rack-and-pinion motion, the cutter passing the emery wheel precisely as though the former was a gear and the latter a complete rack. This motion is obtained by steel tapes wrapped upon a disc representing the pitch diameter of the cutter. While this movement is going on, the emery wheel grinds one side of the cutter teeth to the correct form, one at a time, until the circle is

completed; the cutter is then placed in a second machine, "left hand" to the first, and the opposite sides of the teeth are ground in the same way. The resulting accuracy of the cutter will depend only on the truth of the flat side of the emery wheel, on the straight slide-way on which the cutter is reciprocated, and on the rolling motion. As already pointed out, these operations are not

<sup>1</sup> See works on shop appliances for a description of how to generate a plane surface.

carried out by the user of the machine, but by the maker, and the machines used are completely automatic in all their operations.

It only remains to add that the cutter has clearance; that it has top rake by which the chips are cut off, not pushed off; that, since the cutters are ground to shape after hardening, there are no errors due to hardening; that the same cutter may be used for all gears of the same pitch; that the cutters may be sharpened by grinding the end face of the cutter without change of form of the teeth cut by it; that the machine is equally well suited for cutting internal as well as external gears; and that the output of the machine will depend on the size of the machine and upon the number of change gears and cutters provided.

§ 194. **The Bilgram Bevel-gear Planer.**—The Bilgram planer bears the same relation to bevel wheels that the Fellows shaper does to the spur wheels. Both are of the generating type, and no “former” or pattern tooth is employed as a guide to the cutting tool, as, for example, in the Gibson shaper described in the next article.

To understand the principle on which the action of the machine is based, reference may be made to § 190. It was there shown that if a bevel wheel, having involute teeth, gears with a crown wheel, the development of the teeth of the crown wheel has straight-line faces and flanks. Suppose, therefore, that a tool, having a section similar to that of a tooth of the rack shown in Fig. 347, is caused to reciprocate to and fro along a fixed horizontal line passing through the apex  $O$  of the cone, and that the bevel blank whose axis is  $OB$  can, by some means, roll without slipping round the flat circular rack forming the pitch surface of the crown wheel. At the commencement of the operation, let the bevel blank be on one side of the line of motion of the tool—so that the tool just clears the blank—and during each return stroke of the tool, let the bevel wheel be given a very slight rolling motion over the circular rack of the crown wheel, the bevel blank being held whilst the tool is cutting. By the time the bevel blank has escaped from the cutting tool on the other side, the space between two teeth of the bevel wheel will have been accurately shaped out. The bevel blank must then be rotated about its own axis through a distance

equal to the pitch, and the operation repeated. Thus the tool has a reciprocating motion only, and the tooth shapes are imparted by the intermittent rolling motion of the blank. The tool is set to the angle of the bottom of the tooth, and cuts in the intervals of rest of the blank. The cutting tool is not a pointed tool, but a broad shaving tool, which leaves a more smoothly polished surface on the teeth than a pointed tool will do. It commences cutting at the top edge of the tooth, and as the blank rolls, the cutting edge moves towards the root.

The mechanical details are illustrated in Figs. 353, 354, 355.<sup>1</sup> Fig. 353 represents a photograph of a small-sized semi-automatic machine, and Figs. 354, 355 represent a sectional elevation and plan of a somewhat larger machine. The tool A, attached to a tool box, is caused to reciprocate by means of a connecting-rod, one end of which is attached to the ram of the tool box, and the other to a block which can be clamped in any desired position in a diametral groove in the belt pulley F keyed to the driving shaft, so that the stroke of the tool box can be readily varied. The bevel blank (not shown in Fig. 354) is keyed to the lower part of the arbor B, which can be clamped, at any angle, in a vertical plane between the two uprights C, C, so as to allow of bevel wheels of different cone angles being inserted. The uprights C, C are attached to a horizontal plate, D, which can be moved about a vertical axis that passes through the apex O of the cones, circular guides of V-section being provided in the bedplate for the purpose. A motion, therefore, of D will cause the arbor B, carrying the bevel blank, to move about a vertical axis passing through O. In addition to this motion, the arbor B must also rotate about its own axis, and these combined motions must produce exactly the same effect as if the bevel blank rolled, without slipping, on the crown wheel circular rack. This rolling motion is brought about by means of a roll cone, or roll plate G (better seen in Fig. 353), the rolling face of which is in the horizontal plane through O. The roll cone is attached at its upper end to a plate,

<sup>1</sup> Kindly supplied by Messrs. Pfeil & Co., the agents in this country for Messrs. Reinecker, who make the machine. A very full description, with the method of setting up the work, will be found in *Engineering*, March 21, 1902.

X, loosely encircling the arbor B; and this plate is screwed to a casing, Y, which completely encloses a worm wheel, Z. The worm wheel is clamped to the arbor B, and the worm which meshes with it turns in bearings carried by the casing. Again, at each

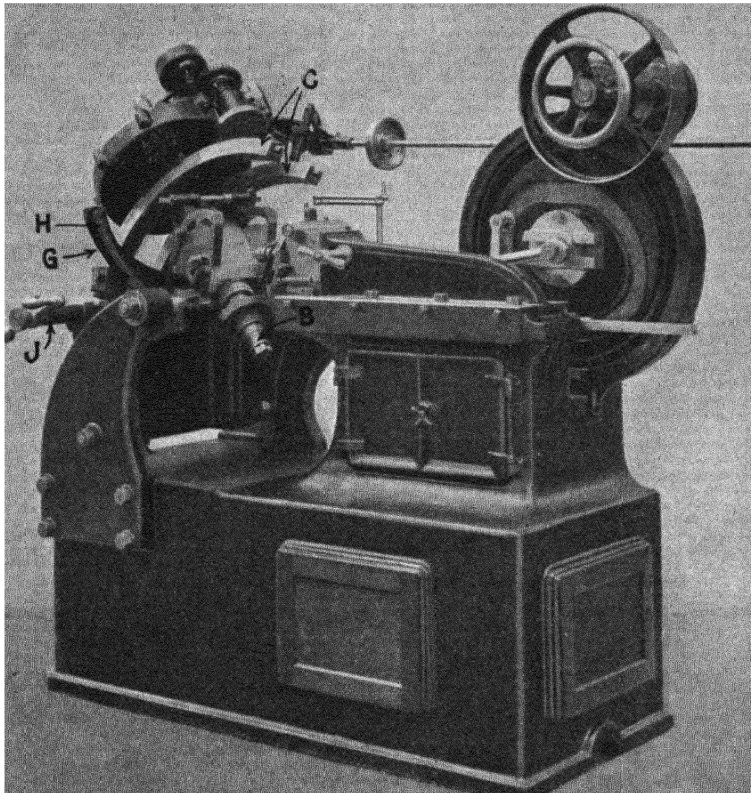

FIG. 353.

extremity of the rolling face of G is attached a flexible steel wire or band, H (clearly shown in Fig. 353), the other end of the two bands being clamped to opposite sides of the frame at J, J (Fig. 355). If, therefore, the roll cone G be rolled on the steel bands, G and the casing will rotate and cause, through the locked worm and worm

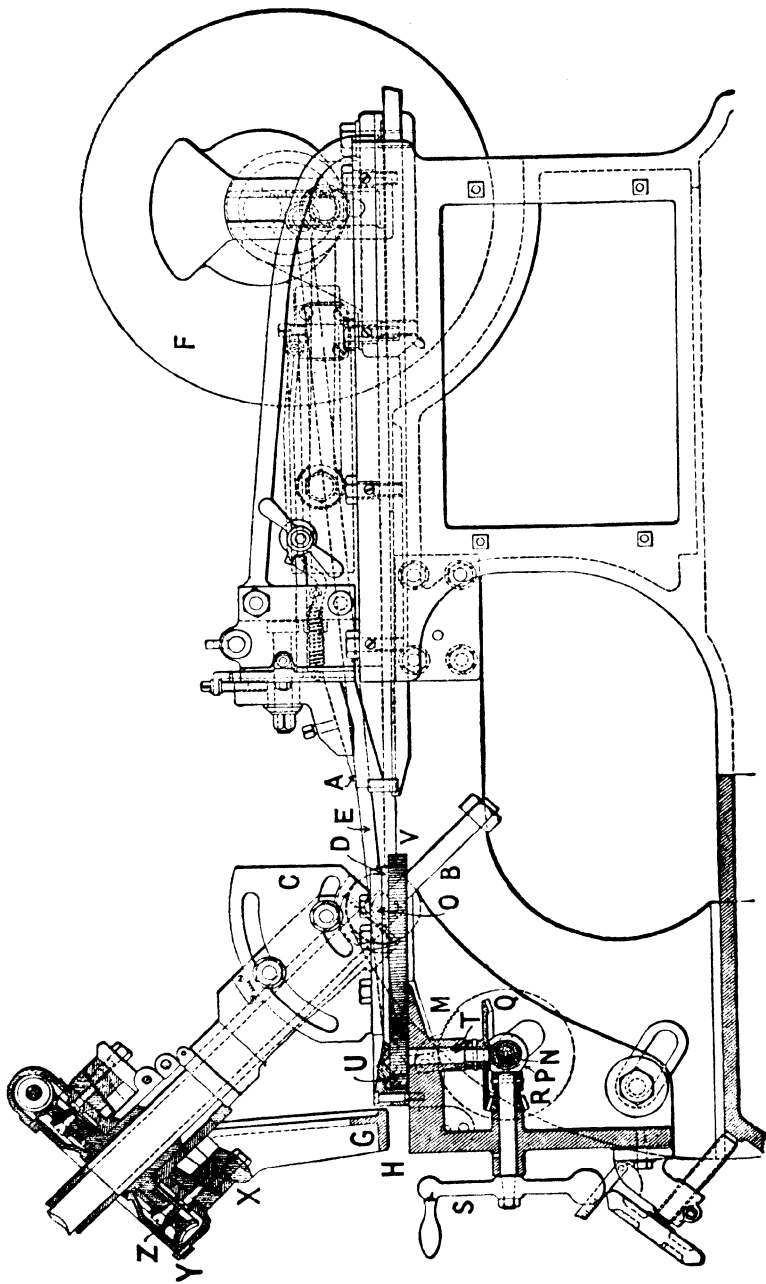

FIG. 354.

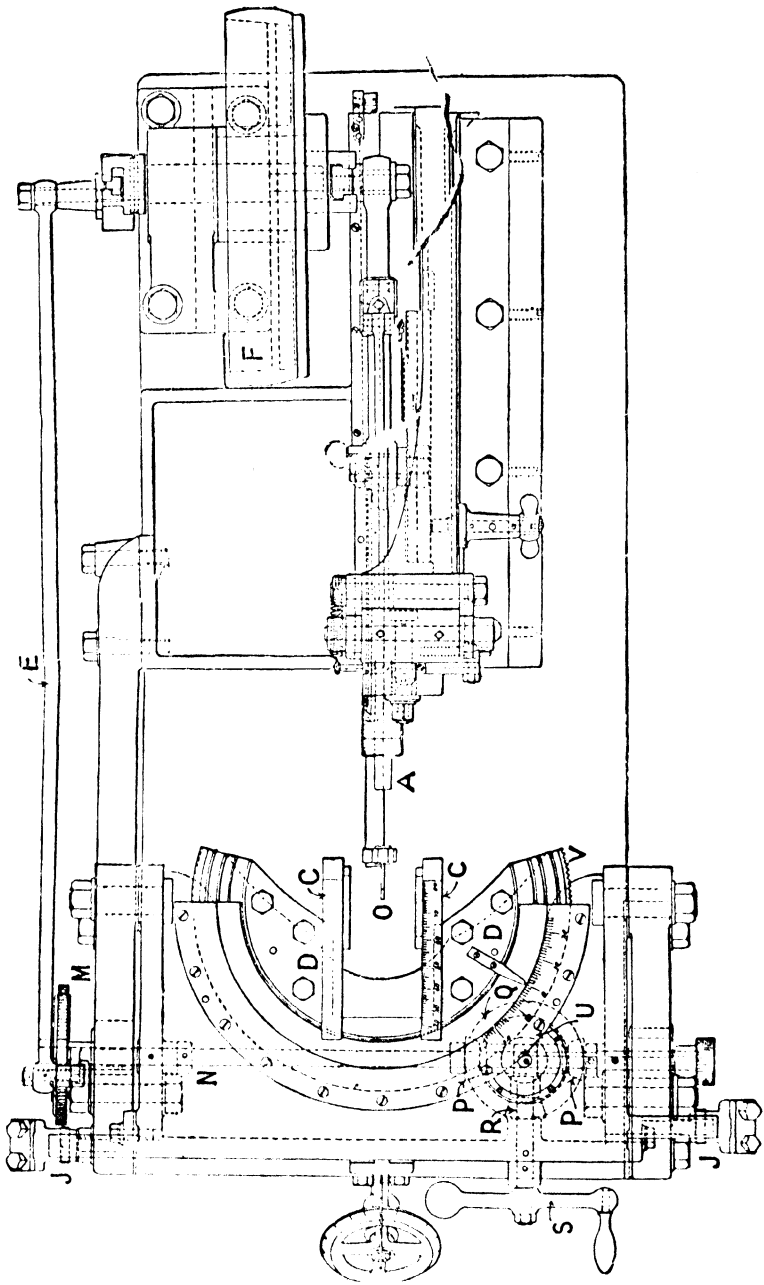

FIG. 355.

wheel, the arbor B to rotate through a corresponding angle; with the result that the bevel blank will have the true rolling motion over the crown wheel circular rack. If G be held fixed, so likewise will the casing, and a rotation of the worm will cause a rotation of the arbor B about its own axis. The same roll cone cannot, of course, be used for different cone angles; but for each cone angle a corresponding rolling cone must be used.

The roll cone G is rolled over the steel bands by a rotation of the horizontal plate D. This may either be by hand or from the driving shaft. The plate D is provided with a circular rack, V, which meshes with a pinion, U, keyed to a vertical stud, T. This stud carries a bevel wheel, Q, which meshes with a wheel, R, which may be rotated by the hand wheel S. Equally, it may mesh with one or other of the bevel wheels P, P (which can be engaged and disengaged by means of a clutch, so that the roll cone can roll in either direction), keyed to a horizontal shaft, N. At its extremity, N carries a ratchet wheel, M, and the intermittent rotation of M may be brought about by a click actuated by the rod F driven from the belt pulley F.

To use the machine, the arbor is placed at the proper cone angle in the vertical plane, and the proper roll cone fitted, and by means of the handle S the roll cone is placed in one of its extreme positions, so that the bevel blank is just clear of the tool. During each return stroke of the tool, the roll cone is given a slight motion either through S or through M. The tool consequently cuts out the tooth space in the blank; and these intermittent operations—alternate cutting by the tool, and rolling of the roll cone—are continued until the blank is clear of the tool on the opposite side of the machine. The worm wheel Y is then rotated, by means of the worm, such an amount as to cause the bevel blank to move through an angle corresponding to the pitch, and the operation is repeated. Usually three tools are used, namely, a double-edged tool (such as has been assumed) for roughing, and right and left handed side tools for finishing.

§ 195. **The Gibson Bevel-gear Shaper.**—In both the Fellows and the Bilgram shapers, the profiles of the teeth are generated, and are necessarily involute teeth, and all wheels cut by the same

cutter will mesh together. In some machines, for example, the Gibson machines used for cutting bevel wheels,<sup>1</sup> any shaped teeth whatever may be cut, because a "template" or "former" is used. Any errors in shaping the "former" are reproduced in the teeth, but on a reduced scale, since the "former" is usually about three times as large as the teeth to be cut.

The principle of this machine has been already pointed out in § 188. Suppose the wheel blank A (Fig. 356) to be made of butter, and that the trace of the teeth on a spherical surface having the apex O of the pitch cone has been drawn; let it be represented by T. Imagine an extremely thin and rigid knitting-needle, N, pivoted at one end to O, and let the needle be guided over the profile T. The needle will sweep out of the soft blank a perfect bevel wheel space, and every peculiarity of the profile T will be faithfully reproduced, in ever-diminishing miniature, as the apex is reached. When the blank consists of metal, it cannot, of course, be cut in this way; but suppose the blank has been roughed out, and that along the direction of the needle a cutting tool, having its cutting corner in the axis of the needle, can reciprocate. Clearly

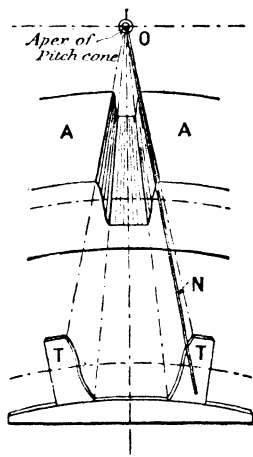

FIG. 356.

if the direction of the needle be fixed whilst the tool is cutting, and if, in the return strokes, the needle (carrying the tool with it) is shifted into successive positions as determined by the space template T, then the cutting edge of the tool will always move along straight lines radiating from O, and the blank will be cut to the proper shape.

The mechanical arrangement of the machine is shown in Figs. 357, 358; Fig. 357 representing a sectional side elevation, and Fig. 358 a plan. The bevel wheel A, to be cut, is mounted on a mandrel, P<sub>1</sub>, one end of which pivots in a small trunnion

<sup>1</sup> See a paper by Mr. J. H. Gibson read before the North-East Coast Institution of Engineers and Shipbuilders, 1897; also *Engineering*, March 26, 1897.

bearing at the apex O of the pitch cone. The other end is capable of movement in a vertical plane, and can be fixed on a graduated quadrant B at any desired angle. A dividing gear, C, turns the blank into successive positions for cutting the required number of teeth, and while each tooth is being cut a pinching screw, D, helps the dividing wheel to hold the wheel blank securely in place.

The reciprocating motion of the tool along lines radiating from O is brought about in the following way. A carrier frame, E, is provided with two forks, F, F (Fig. 358), which can turn about horizontal studs, G, G, whose axis passes through O. These studs are carried by a circular plate, H, guided in a horizontal circular groove, I, whose centre is coincident with O. Thus the frame E can swivel about a horizontal axis through O, and this horizontal axis can be turned in a horizontal plane passing through O. The outer end of the frame E carries a roller, J, and this roller is constrained to move round the enlarged profile of the tooth template T (Fig. 356); the roller being kept pressed against the template by the spring K attached at one end to the roller and at the other end to a fixed stud. The outer end of the carrier frame E terminates in a socket, L, which engages a ball-and-socket joint forming a feed nut, M. The feed nut M is attached to a handle, N, and the screw Q can oscillate about the ball-and-socket joint R in the fixed frame of the machine. Thus the spring K keeps the roller pressed against the template T, and by turning N the roller may be moved over the template.

The carrier frame E carries the sliding ram S with the tool box U. The latter is capable of lateral adjustment by means of the screw V, so as to bring the cutting corner of the tool W on the straight line or "radian" joining the centre of the roller J to the apex O of the pitch cone. The ram is reciprocated by a crank shaft, X (turning in bearings in the frame E), through a crank arm and slot, Y, attached to the ram. The motion is transmitted to X by belting from the pulley Z, which rides loosely over a spindle whose axis is coincident with the axis of G (Fig. 358). The spindle of Z is carried by the circular plate H so that the distance between the axis of X and Z is always the same; and it receives its motion from cone pulleys in the usual way. The stroke of

the cutting tool is varied by altering the radius of the crank arm attached to X.

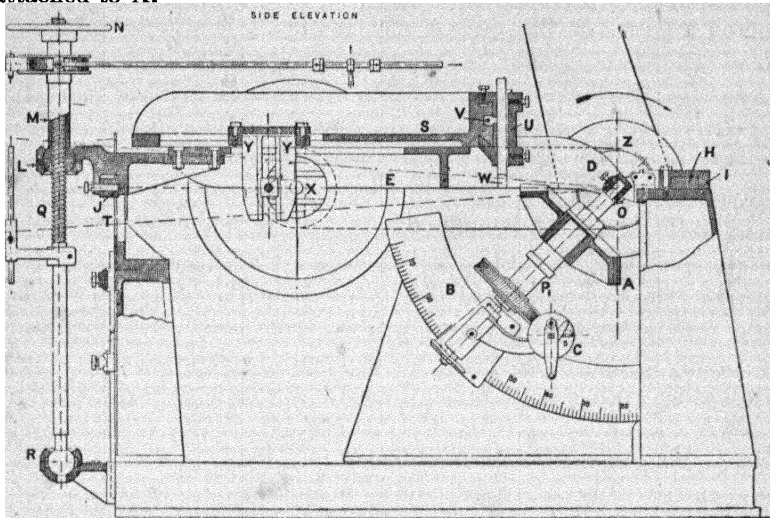

FIG. 357.

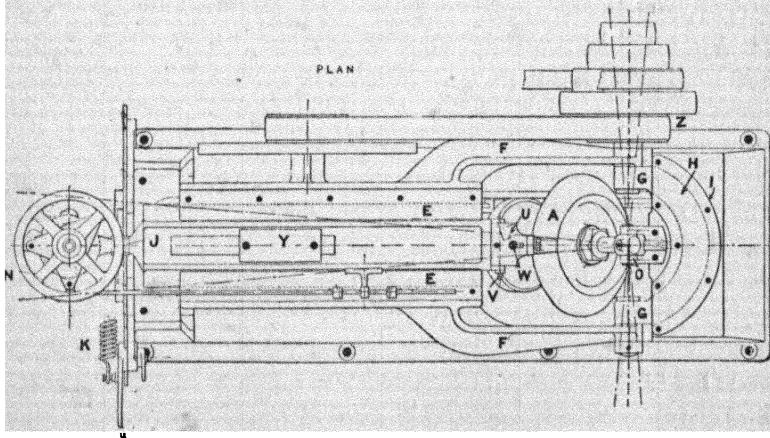

FIG. 358.

The action of the machine is clear. The template or former T corresponds to the development of the teeth on the arc CJ of

Fig. 345. The shape of the template is not the true shape of the tool, but a parallel curve (§ 181). The blank, which has been previously roughed out, is attached to the spindle  $P_1$ , and this spindle is set at the proper cone angle by the graduated arc  $B$ . The roller is pressed over one side of the template by the spring  $K$ . The cutting corner of the tool is placed in the line joining  $O$ , and the centre of the roller  $J$ , by means of the screw  $V$ . The machine is then started, and during each return stroke of the tool the handle  $N$  is given a slight rotation. In this way one side of the tooth can be formed. To cut the side of the next tooth, another tool is used exactly similar to the first, and the roller is pressed on the other side of the tooth space. When this is finished, the spindle  $P_1$  is turned through an angle corresponding to the pitch by the dividing gear  $C$ ; and so on. The nut  $N$  is only turned through a small angle during the return stroke of the tool; during the cutting stroke, the tool simply moves along a radian line. The intermittent motion of  $N$  may be brought about, automatically, by a ratchet wheel, as already described in § 74.

The template  $T$  must correspond to the proper shape of the teeth of each wheel to be cut. It may be so shaped as to cut out either cycloidal or involute teeth. If the same template has to serve for all wheels meshing together and which have the same angle of wheel, then if the teeth be cycloidal teeth, the faces and flanks must be generated by the same rolling circle (§ 177); if they are involute teeth, the obliquity of all will be the same as that of the template (§ 176).

§ 196. **The Gibson Worm-wheel Shaper.**—The object of this machine is to cut out from a worm-wheel blank the proper shape of teeth to mesh with a given worm. It corresponds in principle to the Fellows gear shaper. The leading principles underlying a worm and worm wheel have already been discussed (§§ 36, 191), and the method of action of the present machine may perhaps be best illustrated in the following manner: Imagine the worm wheel to consist of a soft material like butter, and bring the given worm and the worm-wheel blank into the positions which they will occupy when in full gear. Let the worm and worm wheel be rotated by independent gearing at precisely the same relative

speeds as if the worm actually drove the worm wheel. The result will clearly be that the worm will cut out in the worm wheel

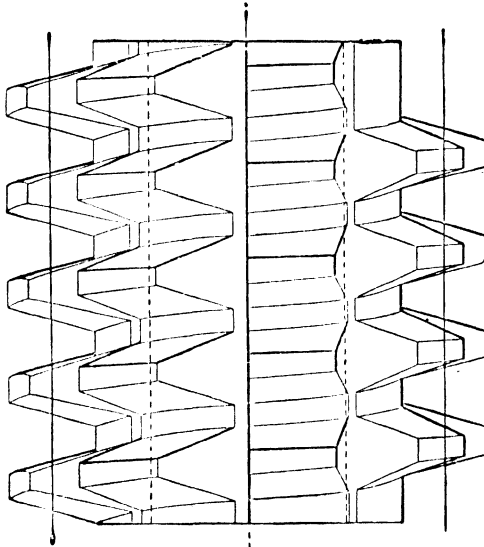

FIG. 360.

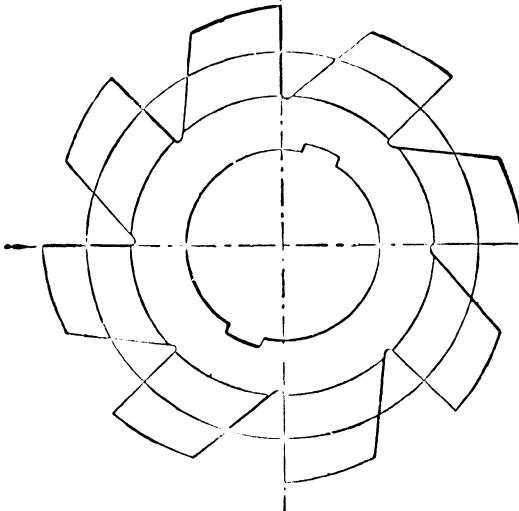

FIG. 359.

teeth of the proper shape to mesh with the worm wheel. In

practice, since the worm wheel is made of metal, the worm has to be provided with cutting edges properly cleared and tempered; and these cutting edges are obtained by giving the worm longitudinal grooves, so that a number of cutting edges are obtained which are stepped slightly behind each other (Figs. 359, 360). Such a cutter worm, acting on a worm wheel already roughed

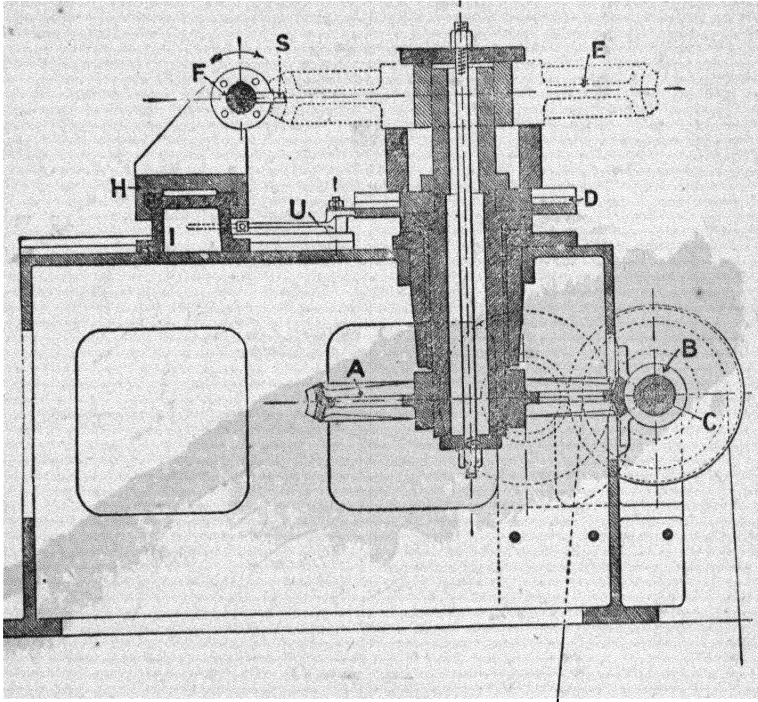

FIG. 361.

out, will cut, in the manner just described, the proper shape of teeth for the worm wheel. During cutting there will be a tendency to push the cutter worm shaft axially.

The machine under discussion acts on this principle, but it has the advantage that the succession of cutting edges of the worm is replaced by a single cutter. It is illustrated in Figs. 361, 362; Fig. 361 being a sectional elevation through the axis of the standard



depending on the number of teeth in the required worm wheel. The last change wheel K is not attached directly to the cutter shaft, but to a nut, L (Fig. 362), which forms a journal and thrust bearing, M, for the standard screw shaft N. This nut has a wheel, O, securely keyed to it, which drives another wheel, P, having one or two more teeth by the pinions Q, which engage the differential wheels on opposite sides. The wheel P rotates with the standard screw shaft N, but the screw shaft can slide inside the boss of P because it is provided with a feather key. A rotation, therefore, of the star wheel R, keyed on the same spindle as Q, causes relative motion between the differential wheels O and P, and compels the standard screw N to thread itself through the nut (as in the drilling machine described in § 61); but if the star wheel remain at rest, the whole gear revolves together, and maintains a rigid connection between the last change wheel K and the cutter S. The star wheel is only actuated intermittently through a small angle once in each revolution of the worm-wheel blank E, and this is automatically brought about, through link-work, by means of a cam or projection, T, engaging a lever, U.

The operation of cutting is as follows: The tool is brought over until it just touches the worm-wheel blank at V. The machine is then started, and the tool nibbles away until the blank has made one complete revolution, the tool in the mean time having no axial motion. The number of turns of the cutter is, in this interval, equal to the number of teeth that the finished worm wheel will have, so that the "nibbles" are spaced at a distance apart equal to the pitch. After one complete revolution of the worm-wheel blank, the star is engaged, and the tool is shifted round to another position near to the first, in the dotted helix X, by the standard screw being threaded into the nut L. The operations then continue automatically until the cutter has worked itself right across the chord and emerges at Y, when the wheel is finished. As the automatic adjustment of the cutter is made once during each revolution of the worm-wheel blank, it will be noticed that the action on every tooth is exactly alike. The shape of the cutter is arbitrary, and, in particular, might be straight (§ 190), in which case the mid-section of the worm wheel will have involute teeth.

If it be desired to cut a double-threaded worm, two cutters must be used, fixed diametrically opposite each other; for a triple-threaded worm, three cutters at  $120^\circ$  must be used; and so on. A left-handed screw and nut (N and L) must be used in cutting left-handed worm wheels, in which case the tool starts at Y and ends at V.

§ 197. **Rotary Pumps and Blowers.**—It has been already pointed out (§ 173) that the problem of finding the proper shapes of two curved surfaces, which by sliding contact transmit the same motion as the pitch circles would transmit by rolling contact, also occurs in rotary pumps and blowers. The object in view is, however, quite different in the two cases.

The method of action of a rotary pump will be evident from Figs. 363, 364, 365, which represent a section of the pump perpendicular to the axes of rotation. The curved plates L and M, exactly similar in shape, are keyed to the two shafts  $P_1$  and  $P_2$ , which rotate with equal but opposite angular velocities in bearings in the casing C. The equivalent pitch circles of

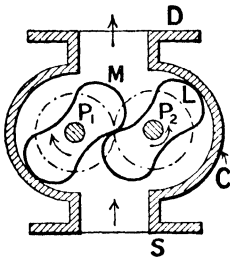

FIG. 363.

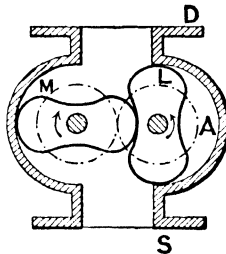

FIG. 364.

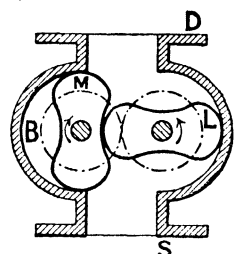

FIG. 365.

the plates or "pistons" are represented by the two chain-dotted circles of equal diameter; and the sides of the casing are arcs of circles having  $P_1$  and  $P_2$  as centres. The pistons are, therefore, always in contact with the casing at one or other of the extremities of their major axes, and their shape is such that they are always in contact with each other. The suction pipe is coupled to the casing at the flange S, and the delivery pipe at the flange D. As shown in Fig. 363, the piston L is rotating in a counter-clockwise direction, and the piston M in a

clockwise direction. When the shafts have turned through a certain angle, the pistons will be as shown in Fig. 364. It will be noticed that the space A, which in Fig. 365 is in communication with the suction pipe, is now entirely cut off, and any fluid in it will, neglecting leakage, be carried round with the piston L. After a short time, the upper extremity of the major axis ceases to have contact with the casing, and the space A is put in communication with the delivery pipe. No further transference of fluid from the suction pipe takes place until the position of the pistons is as shown in Fig. 365, when the space B is put into communication with the delivery pipe. Since the space above the pistons in Fig. 364 is exactly the same as in Fig. 365, it follows that, whatever the fluctuations in volume have been in the interval, the whole of the fluid which occupied the space A has been discharged up the delivery pipe. It will thus be seen that the total volume of fluid pumped up per revolution is equal to four times the volume of the space A; or, expressed more generally, is equal to twice the difference between the area of a circle having a diameter equal to the major axis of the piston and the area of the piston itself, multiplied by the axial length of the piston.

In Fig. 363 each piston has two projections and two hollows, but the number of teeth is arbitrary. Fig. 366 shows a pump in which the pistons have six teeth. As in the previous case, the theoretical discharge is equal to the area of the two addendum circles less the area of the pistons, multiplied by the axial length of the pistons.

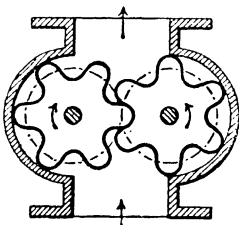

FIG. 366.

It will be noticed that leakage is prevented by the contact of the pistons with the casing and with each other. Sliding, and therefore wear, takes place not only between the pistons and the casing, but also between the pistons themselves, and it is a matter of difficulty to keep a fluid-tight contact. It is for this reason that, notwithstanding their great simplicity and the absence of valves, they are not often used as water-pumps. They are, however, frequently used for supplying the blast to furnaces (as in Root's

blowers), and also for pumping thick pasty fluids which might interfere with the proper working of the valves.

There are two points of detail which ought to be noticed. In the *first* place, if toothed pistons are used, as shown in Fig. 366, one wheel can always act as driver to the second; but with the pistons shown in Fig. 363 this would be impossible in certain portions of the revolution. The shafts  $P_1$  and  $P_2$  almost invariably, therefore, receive the equal and opposite rotations from two equal spur wheels which gear with each other, and are keyed to the shaft on the outside of the casing—the wheels being driven, through gearing, from the engine. The object of the pistons is, in fact, merely to preserve contact, and not to transmit force from one to the other. In the *second* place, the circular sides of the casing must be rather more than a semi-circumference in length, or otherwise communication would be opened with the delivery pipe before that with the suction pipe was closed.

§ 198. **Shapes of Blowers.**—The shapes given to the rotatory pistons is arbitrary provided they satisfy the condition that the motion transmitted by their sliding contact is exactly the same as that which would be transmitted by the rolling contact of the two pitch circles; in other words, provided the common normal at the point of contact of the pistons always passes through the pitch point. The point of contact will not always lie on the line of centres, and the velocity of sliding at any instant will be equal to the length of the common normal to the two surfaces, measured to the pitch point, multiplied by twice the angular velocity of either wheel (§ 172).

It has been shown, that cycloidal curves satisfy the required condition—the parts of the piston above the pitch circles being epicycloids, and the parts below hypocycloids. The size of the rolling circle—which, since the pistons are invariably of the same shape, will be the same for both the projection and the hollow—will depend on the number of teeth in the piston, but the diameter of the pitch circle must be an exact multiple of the diameter of the rolling circle. If the pistons are two-toothed wheels, as shown in Fig. 363, the diameter of the rolling circle will be one-quarter that of the pitch circle, and the points where the piston profile

crosses the pitch circle will divide the latter into four equal parts (as in *Root's blower*). If the pistons are six-toothed wheels, as shown in Fig. 366, the diameter of the rolling circle is one-twelfth that of the pitch circle; and so on. Fig. 367 shows

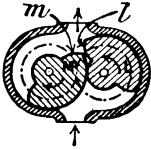

FIG. 367.

a pair of pistons consisting of two half-cylinders of different diameters and connected by the curves *l* and *m*. The circular portions roll without slipping, and the curves *l* and *m* must satisfy the necessary kinematic condition. If the portion below the pitch circles be a radial straight line, the portion

above it must be an epicycloid formed by a rolling circle half the size of the pitch circle.

The profiles need not, however, consist of curves possessing any particular mathematical properties. If the profile of one of the pistons is given, that of the second can be found by the geometrical or mechanical method of § 173.

For example, Fig. 368 shows an illustration of the geometrical

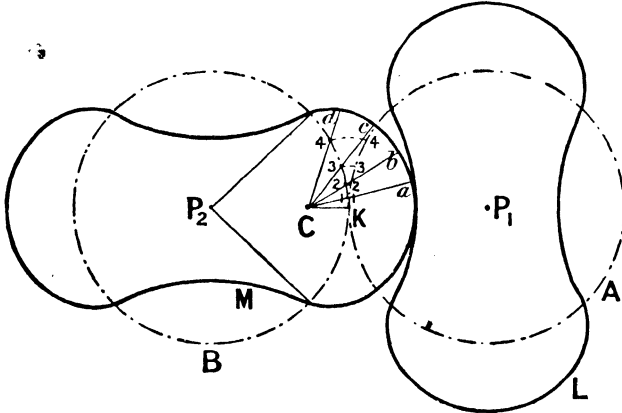

FIG. 368.

method in which the "points" of each piston are circular arcs subtending an angle of  $90^\circ$  at the centre—the height of the point being taken as half the radius of the pitch circle. The centre of the circle forming the point of the piston keyed to  $P_2$  is  $C$ , and, following the method of § 173, a number of normals through the

points  $a, b, c, \dots$  are drawn to the circular arc. These all necessarily pass through the point  $C$ , and they intersect the pitch circle  $B$  of centre  $P_2$  in the points  $1, 2, 3, \dots$ . With  $K$  (the pitch point) as centre, arcs passing through the points  $1, 2, 3, \dots$  are struck to meet the pitch circle  $A$  in the points  $k_1, k_2, k_3, \dots$ . This construction, since the pitch circles are equal, merely makes the arcs  $K_1, K_2, K_3, \dots$  on each pitch circle the same. With the points  $k_1, k_2, k_3, \dots$  on  $A$  as centres, and radii equal to  $1a, 2b, 3c, \dots$  circular arcs are drawn; and the envelope of these arcs is the proper shape of the hollow of the piston on  $P_1$  to gear with the given "point." The whole pistons are as shown.<sup>1</sup> Other shaped pistons, obtained in the same way, are shown in Fig. 369.

In the mechanical method, a template of one piston would be cut out, and the two pitch circles would roll together as explained in § 173. The profile of the given piston would be marked off on the sheet rotating about the second centre; and the envelope of the curves so obtained would be the shape of the second piston. In Fig. 369 the shape of the second piston is governed by the path of the extreme points of the first piston.

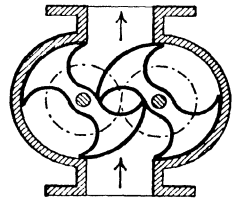

FIG. 369.

<sup>1</sup> For a development of this method, see an article in the *Mechanical Engineer* for January 1, 1899

## CHAPTER VIII.

### NON-CIRCULAR WHEELS ROTATING ABOUT PARALLEL AXES.

THE preceding chapter refers to circular wheels rotating about parallel axes, in which case the angular-velocity ratio is constant and inversely proportional to the radii of the pitch circles. The circular pitch surfaces are replaced by teeth whose working profiles satisfy the only kinematic condition necessary, namely, that their common normal at the point of contact must always pass through the pitch point.

§ 199. Determination of Angular-velocity Ratio when Contact always takes place in Line of Centres. Velocity of Sliding Zero.—

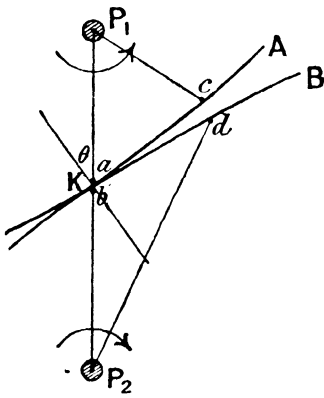

FIG. 370.

Next, let us consider the more general case in which the pitch lines are not circles, but are any curves whatever. In Fig. 370, let A and B be two non-circular plates rotating about fixed centres  $P_1$  and  $P_2$ , which, by contact with each other, cause a motion of rotation to be transmitted from the first to the second. Whatever the precise shapes of the plates are, they must clearly be such as to have a common normal at their point of contact. Let us also assume, in the first place, that

the point of contact lies in the line of centres in all positions of the plates. As sketched, if A rotate in a counter-clockwise direction about  $P_1$ , it will cause, by direct action, the

plate B to rotate in a clockwise direction about  $P_2$ . If the angular velocity of A about  $P_1$  be known, the angular velocity of B about  $P_2$ , and also the velocity of sliding of the two plates over each other, may be found in the following manner: Let  $\omega_1$  be the known angular velocity of A about  $P_1$ , and  $\omega_2$  the (unknown) angular velocity of B about  $P_2$ ; moreover, let  $a$  and  $b$  be the two points, one in each plate, which at the instant are coincident with the point of contact K. Then the point  $a$  is moving perpendicularly to  $P_1P_2$  with a velocity  $\omega_1 \cdot P_1a$  from left to right; and the point  $b$  is also moving perpendicularly to  $P_1P_2$ , in the same direction, with the velocity  $\omega_2 \cdot P_2b$ . The relative velocity of the points  $a$  and  $b$  in a direction perpendicular to  $P_1P_2$  is therefore  $(\omega_1 \cdot P_1a - \omega_2 \cdot P_2b)$ ; consequently, the relative velocity in the direction of the normal to the two curves is  $(\omega_1 \cdot P_1a - \omega_2 \cdot P_2b) \sin \theta$ , and in the direction of the tangent  $(\omega_1 \cdot P_1a - \omega_2 \cdot P_2b) \cos \theta$ , where  $\theta$  is the angle between the line of centres and the common normal to the two plates. If the plates keep contact, and one does not penetrate into the other, the relative velocity in the direction of the normal must necessarily be zero; and so, likewise, will the relative velocity in the direction of the tangent, that is to say, the sliding velocity, be zero also. Thus, so long as the plates are always in contact on the line of centres, the angular-velocity ratio is inversely as the segments into which the line of centres is divided by the point of contact, and there is no slipping between the plates; and unless the plates are circular, the velocity ratio will vary from moment to moment. The case where the point of contact does not lie on the line of centres is discussed in § 206.

If the plates are always in contact in the line of centres, it follows that the sum of corresponding radii, that is to say, radii drawn to points which come together on the line of centres, must be constant and equal to the distance between the centres. Thus if, in Fig. 370, the points  $c, d$  on the two plates coincide on the line of centres, the sum of  $P_1c$  and  $P_2d$  must be equal to  $P_1P_2$ . Moreover, since there is no slipping, the arc  $ac$  must be equal in length to the arc  $bd$ . These two conditions enable us to find graphically the shape of one of the plates when that of the other is given.

§ 200. To determine the Shape of one Pitch Curve when that of the First is given.—Let the shape of the plate A be as shown in Fig. 371. Take a number of points,  $a_1, a_2, a_3, \dots$  so near to each other that there is no appreciable error in taking the length of a chord to be equal to that of the arc between any two consecutive points. With  $P_1$  as centre draw circular arcs to pass through these points and to intersect the line of centres in the

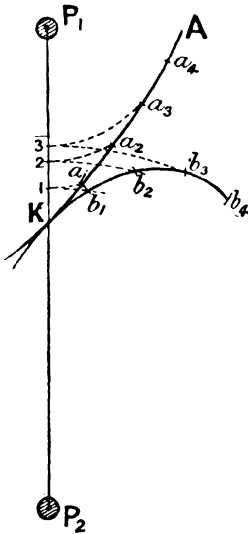

FIG. 371.

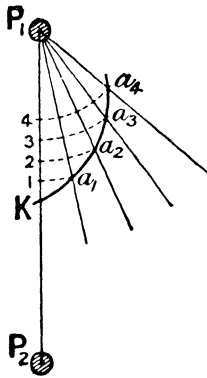

FIG. 372.

points 1, 2, 3, . . . ; and with  $P_2$  as centre draw circular arcs passing through the points 1, 2, 3, . . . With  $K$  as centre and radius  $Ka_1$ , draw an arc to cut the circle through the point 1 in  $b_1$ ; with  $b_1$  as centre and  $a_1a_2$  as radius, draw an arc to cut the circle through the point 3 in  $b_2$ ; with  $b_2$  as centre and radius  $a_2a_3$ , draw an arc to cut the circle through the point 3 in  $b_3$ ; and so on. The proper

shape for the second curve will be obtained by drawing a smooth curve through  $K, b_1, b_2, b_3, \dots$ . The successive velocity ratios

will be  $\frac{P_2K}{P_1K}, \frac{P_2b_1}{P_1a_1}, \frac{P_2b_2}{P_1a_2}$ , etc.; and at no point will there be slipping between the two curves.

Instead of having the shape of the first curve A definitely given, certain data may be known from which A could be drawn. Thus, for example, suppose that certain velocity ratios are required corresponding to certain angles turned through by A. In Fig. 372, it has been assumed that the velocity ratio of  $P_1$  to  $P_2$ , when A turns through equal angles of  $15^\circ$ , are 1.0, 1.1, 1.2, 1.3, etc. The distance between the centres must be subdivided at

the points  $K, 1, 2, 3, \dots$  in the above ratios, and from  $P_1$  radiating lines must be drawn inclined at  $15^\circ$  with each other. If circles with  $P_1$  as centre be described to pass through the points  $1, 2, 3, \dots$  to meet the radiating lines in  $a_1, a_2, a_3, \dots$ , a curve joining these points will give the shape which must be assigned to  $A$  to satisfy the given conditions; and the shape of the curve  $B$  may then be found as before.

A few applications of non-circular wheels may be noticed.

§ 201. **Harfield's Steering Gear.**—The rudder of a ship is actuated from the steering engine either by gearing or some kind of link motion. The force necessary to turn the rudder round increases as the angle turned through, measured from the fore-and-aft plane, increases; and consequently, in most rudder gears, the object aimed at is to make the velocity ratio between the rudder-head and engine shaft get less as the helm angle increases. An arrangement satisfying this condition is shown in Fig. 373, which

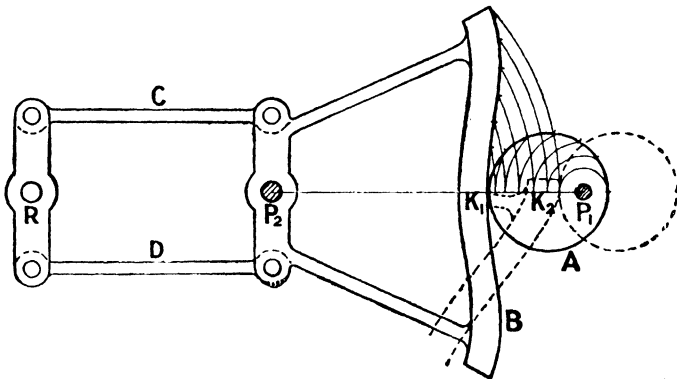

FIG. 373.

represents *Harfield's gear*. The circular wheel  $A$  is keyed to an eccentric shaft,  $P_1$ , which is driven through ordinary gearing from the steering engine. The wheel  $A$  gears with a non-circular rack,  $B$ , which rotates about the fixed centre  $P_2$ . The motion of rotation is transmitted to the rudder-head  $R$  by equal and parallel rods,  $C$  and  $D$ , so that the velocity ratio between the rudder-head and the shaft  $P_2$  is constant and equal to unity. If the axis  $P_1$  were

concentric with A, the rack B would be circular, and the velocity ratio between the rudder-head and steering engine would be constant. By placing A eccentric to  $P_1$ , the velocity ratio varies from moment to moment, getting less and less as the rudder is put over. Thus, in the central position, the velocity ratio is  $\frac{P_1K_1}{K_1P_2}$ ; in the extreme position, when A makes half a turn, the rack takes up the position shown by the dotted curve, and the velocity ratio is  $\frac{P_1K_2}{K_2P_2}$ . Usually the maximum helm angle is about  $35^\circ$ , and the angular-velocity ratio in the extreme position is about  $\frac{1}{2}$  to  $\frac{1}{3}$  that in the mean position. The form of the rack B is obtained by the method just described, and the construction for half the rack is reproduced. Ollis' gear (described in § 152) obviates the necessity of using a non-circular rack, B.

§ 202. **Quick-return Motions.**—The same principle is sometimes applied to shaping and punching machines in order to obtain a

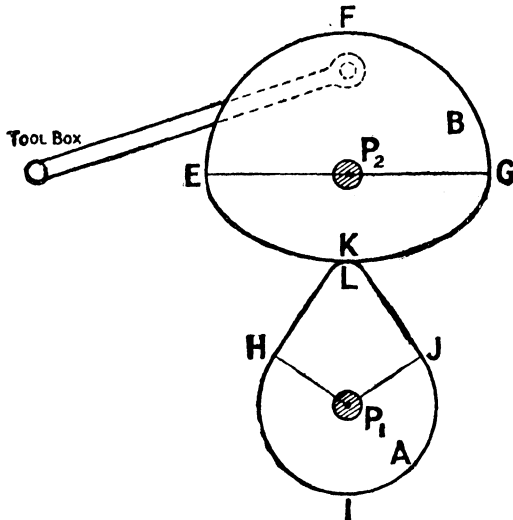

FIG. 374.

quick-return motion. In Fig. 374, A represents a wheel keyed to the shaft  $P_1$ , driven through gearing from the countershaft, and

which in turn drives the wheel B keyed to the shaft  $P_2$ . The tool box is actuated by a connecting-rod turning on a pin attached to the wheel B. The portion EFG of the wheel B, subtending an angle of  $180^\circ$  at the shaft  $P_2$ , is circular, and meshes with the circular portion HIJ of the wheel A. The portion EKG of the wheel B is given any arbitrary form, and gears with the portion HLJ of the wheel A, the proper shape of the latter being determined by the previous considerations. The angle subtended by the arc HIJ at the centre  $P_1$  bears the same ratio to  $180^\circ$  as the radius of the arc EFG bears to that of HIJ. Thus the angle turned through by  $P_1$  when  $P_2$  turns through  $180^\circ$  is alternately greater and less than  $180^\circ$ ; or, to express it differently, if  $P_1$  rotate uniformly, the shaft  $P_2$  describes one half of its revolution in less time than the other half, the "time ratio" being the angle subtended by the arc HIJ at  $P_1$  divided by twice the supplement of that angle. The mechanism may therefore be used as a quick-return motion. During the cutting stroke, the shaft  $P_2$  rotates uniformly, but during the return stroke its angular velocity varies. The velocity ratio between  $P_2$  and  $P_1$  has a minimum value of  $\frac{P_1H}{P_2E}$

and a maximum value of  $\frac{P_1L}{P_2K}$ . This motion is very frequently used to give the quick return to the ram of a slotting machine.

§ 203. **Elliptic Wheels. Equivalent Four-bar Chain.**—In the two illustrations just discussed, the shape of one of the wheels has been assumed given, and the shape of the second wheel, which moves in rolling contact with the first, has been obtained geometrically. But there are certain well-known curves, possessing some mathematical property, which satisfy the conditions laid down in § 199. The most important of these are equal elliptic wheels rotating about one of their foci, the distance between the centres of rotation being equal to the major axis of either ellipse. The wheels, in two positions, will therefore be in contact at the extremities of their major axes. One such position is shown in Fig. 375, the centres of rotation being the foci  $P_1$ ,  $P_2$ , and the remaining foci being C and D. If two points,  $e$  and  $f$ , be taken, one in each ellipse, such that the lengths of the arcs  $Ee$  and  $Ff$  are equal, it

is clear that the focal distances  $P_1e$ ,  $Ce$  are respectively equal to  $Df$ ,  $P_2f$ , so that the sum of the radii  $P_1e$ ,  $P_2f$  is equal to the sum of  $P_1e$  and  $Ce$ , or of  $P_2f$  and  $Df$ ; consequently, from a well-known property of the ellipse, the sum of  $P_1e$  and  $P_2f$  is equal to the axis-major of either ellipse, and therefore to the distance between the rotating centres. The points  $e$  and  $f$  will therefore come together in the line of centres (Fig. 376), and since the arcs

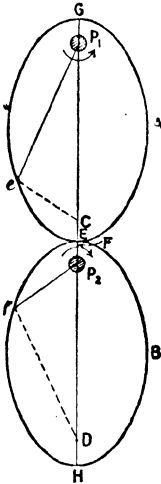

FIG. 375.

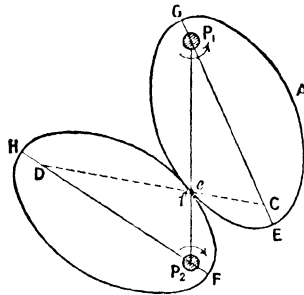

FIG. 376.

$Ee$ ,  $Ff$  are equal, the two wheels will not slip over each other. The velocity ratio of the shafts  $P_2$  and  $P_1$  is clearly equal to  $\frac{P_1e}{P_2f}$ , and the extreme values of this ratio are  $\frac{P_1E}{P_2F}$  and  $\frac{P_1G}{P_2H}$ , the second being the reciprocal of the first. Expressed otherwise, if  $l$  be the major axis, and  $f$  the distance between the foci of either ellipse, the angular-velocity ratio varies between the limits  $\frac{l+f}{l-f}$  and  $\frac{l-f}{l+f}$ , whilst the mean angular-velocity ratio for each half of a revolution, reckoned from the positions for which the major axes are vertical, is equal to unity.

It will be noticed (Fig. 376) that the triangles  $P_1eC$  and  $P_2eD$  are equal in all respects, so that, since the point of contact lies on the line joining  $P_1$  and  $P_2$ , it must also lie on the line joining  $C$  and  $D$ ; and, moreover, the distance between the foci  $C$  and  $D$  is constant and equal to  $P_1P_2$ . Hence the points  $C$  and  $D$  may be

connected by a link of invariable length, without in any way constraining the motion. This enables us to plot the position of one wheel corresponding to a given position of the other; for the points C and D describe circles about  $P_1$  and  $P_2$  respectively, and are always the same distance apart.

If one of the ellipses be fixed, the other will roll, in pure rolling, round it; and the motion will be precisely the same as

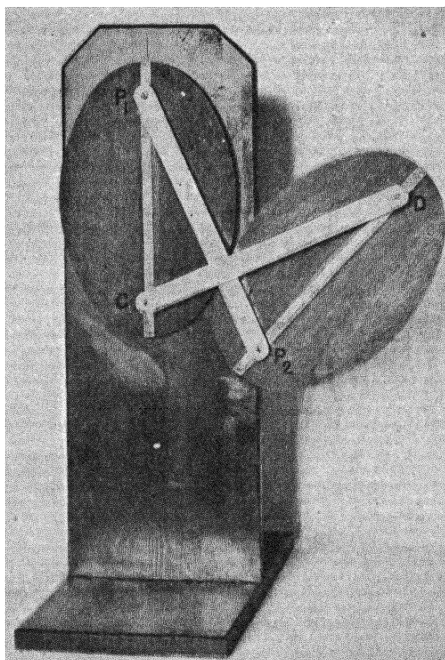

FIG. 377.

that of a certain four-bar chain. A photograph of the arrangement is shown in Fig. 377, in which one board is fixed and the other rolls round it. The major axis of the rolling ellipse has a certain motion impressed upon it; and that motion is exactly the same as if the foci were connected crosswise, with equal links, as shown. The point of intersection of the crossed links is always over the point of contact of the two ellipses.

Elliptic wheels may be also used to give a quick-return motion. Suppose that  $P_1$  is the driver, and draw the mechanism in the position for which the axis major of the follower  $P_2$  is horizontal, as shown in Fig. 378. Since the axes of the ellipse were in the same vertical line together, it follows

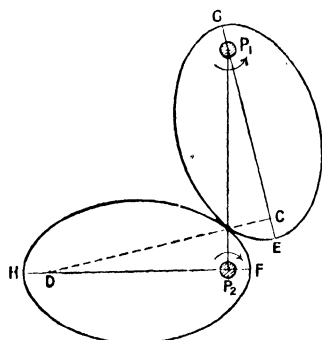

Fig. 378.

that the follower  $P_2$  has turned through  $90^\circ$  whilst the driver has turned through the angle  $P_2P_1C$ ; thus, whilst the follower turns through the two halves of a revolution, measured from the horizontal position of its major axis, the driver will turn through twice the angle  $P_2P_1C$ , and twice the supplement of that angle respectively. If, therefore,  $P_1$  rotate uniformly,  $P_2$  will describe its two

half-revolutions in different times, and therefore a tool box, whose line of motion produced passes through  $P_2$ , may be given a quick return, the time ratio being the supplement of the angle  $P_2P_1C$  divided by the angle  $P_2P_1C$ .

§ 204. **Logarithmic Wheels ; Lobed Wheels.**—A further illustration of rolling plates formed by regular curves is logarithmic wheels. At corresponding points, such as  $cd$  in Fig. 370, or  $ef$  in Fig. 375, the angle between the tangent to the curve and the radius drawn to the centre of rotation must be equal to each other, since the curves have a common tangent when the points  $c$  and  $d$ , or  $e$  and  $f$ , come together at the pitch point. This condition has not previously been specifically mentioned, but it must be understood that it is no new condition, but that it is necessarily true if the two conditions laid down in § 199 are satisfied.<sup>1</sup> In point of fact, there are three conditions to satisfy, but

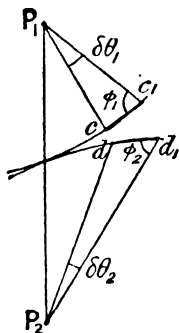

Fig. 379.

<sup>1</sup> To prove this statement, let  $c, c_1$  and  $d, d_1$  (Fig. 379) be arcs which mesh with each other, that is to say, let  $c, d$  and  $c_1, d_1$  be a pair of corresponding points. Let the radii  $P_1c, P_1c_1$  be  $r_1$  and  $r_1 + \delta r_1$ , and the radii  $P_2d, P_2d_1$  be  $r_2$  and  $r_2 + \delta r_2$ . Then the two conditions in § 199 expressed analytically

these conditions are not independent, so that if two of them are satisfied the third is necessarily also satisfied. The condition that the angle between the tangent and the radius at corresponding points must be the same in each curve is clearly satisfied by making the "obliquity" the same for every point of the two curves. The shape of the plates would then be logarithmic spirals,<sup>1</sup> and when, for any equal lengths of arcs for the two curves, the difference in lengths of the extreme radii is the same in each, the two arcs will be of equal length; and consequently, two logarithmic spirals of equal obliquity, rotating about their poles, will move in rolling contact through an indefinite angle.

If the motion has to be continuous in one direction, each wheel must consist of a number of alternately reversed spirals. The

$$\begin{aligned} r_1 + r_2 &= r_1 + \delta r_1 + r_2 + \delta r_2 \\ \therefore \delta r_1 + \delta r_2 &= 0; \\ \text{and } (r_1 \delta \theta_1)^2 + (\delta r_1)^2 &= (r_2 \delta \theta_2)^2 + (\delta r_2)^2 \\ \therefore r_1 \delta \theta_1 &= r_2 \delta \theta_2 \end{aligned}$$

in which  $\delta \theta_1, \delta \theta_2$  are the angles which the arcs subtend at their respective centres; whence—

$$\begin{aligned} \frac{r_1 d\theta_1}{dr_1} &= \frac{r_2 d\theta_2}{dr_2} \\ \text{or } \tan \phi_1 &= \tan \phi_2 \end{aligned}$$

and therefore the obliquities are the same.

<sup>1</sup> In a logarithmic spiral—

$$\begin{aligned} r \frac{d\theta}{dr} &= \text{const.} = \frac{1}{a}, \text{ say} \\ \therefore \frac{dr}{r} &= a d\theta \\ \text{or } \log_e r &= a\theta + \text{const.} \\ \text{If } r &= r_0 \text{ when } \theta = 0, \log_e \frac{r}{r_0} = a\theta \\ \text{or } r &= r_0 e^{a\theta} \end{aligned}$$

As  $\theta$  increases in arithmetical progression, the radii increase in geometrical progression. If the obliquity is given,  $a$  is known, and also if  $r_0$  is given,  $r$  can be calculated for different

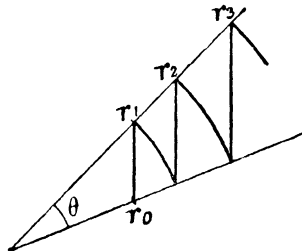

FIG. 380.

values of  $\theta$ . Or, having calculated one value  $\frac{r_1}{r_0}$ , subsequent values can be found for equal increments of  $\theta$  by drawing two lines inclined at an angle  $\theta$  (or any other angle) and measuring off  $r_0$  and  $r_1$  along them. By drawing alternate circles and parallel lines, as shown in Fig. 380, subsequent values of  $r$  are at once obtained.

wheels are then called "lobed" wheels. Fig. 381 shows a pair of unilobe, and Fig. 382 a pair of bilobe wheels working together.

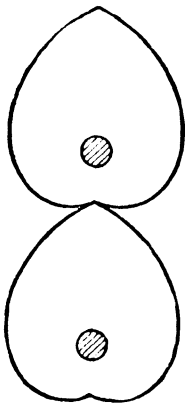

FIG. 381.

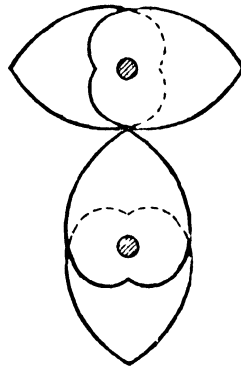

FIG. 382.

§ 205. **General Case of Curved Plates rotating about Parallel Axes.**—In the preceding articles we have discussed the question of non-circular plates which move in pure rolling contact about fixed centres, the necessary condition being that the point of contact should always lie on the line of centres. The pitch circles of ordinary spur wheels are a particular case, and it has been shown how the rolling contact of the pitch circles may be replaced by the sliding contact of toothed wheels, the teeth being given such shapes that a constant velocity ratio is transmitted by their sliding contact. We have now to consider the most general case of sliding contact in which the velocity ratio is not constant, but varies from point to point.

§ 206. **Determination of Angular-velocity Ratio and Sliding Velocity.**—Let  $P_1$ ,  $P_2$  be the two axes, and  $L$ ,  $M$  the two curved plates which rotate about  $P_1$  and  $P_2$ , respectively, and let the point of contact be  $D$  (Fig. 383). It is obvious that, for smooth working, the plates must have a common tangent, and therefore a common normal, at their point of contact. If  $L$  rotate about  $P_1$  in a clockwise direction, it will press on  $M$  and cause it to rotate about  $P_2$ , also in a clockwise direction, since the common normal

(in Fig. 383) lies on the same side of the two centres  $P_1, P_2$ ; and as motion takes place there will be considerable sliding between the two surfaces. If the angular velocity of  $L$  about  $P_1$  be known, the angular velocity of  $M$  about  $P_2$ , and the velocity of sliding of the two plates at the instant, may be obtained by either of the following two methods:—

*First*, by the diagram of velocities.

Let  $\omega_1$  be the angular velocity of  $L$  about  $P_1$ , supposed known, and  $\omega_2$  that of  $M$  about  $P_2$ , as yet unknown; moreover, let  $l$  and  $m$  be the two points, one in each surface, which at the instant are coincident with the point of contact  $D$ . Then the point  $l$  is moving perpendicularly to  $P_1l$  with a velocity equal to  $\omega_1 \cdot P_1l$ , and the point  $m$  is moving perpendicularly to  $P_2m$  with the (unknown) velocity  $\omega_2 \cdot P_2m$ ; whilst the relative velocity of  $l$  and  $m$  must, of necessity, be along the direction of the common tangent—provided, that is to say, that the plates keep contact. The latter statement is obviously true, because if the points  $l$  and  $m$  have a component relative velocity along the common normal, the surfaces would either separate from, or penetrate into, each other. Thus, using the notation of Chap. V., the velocity diagram is as shown in Fig. 384, in which  $pl$  denotes the velocity of  $l$  about  $P_1$ ,  $pm$  the velocity of  $m$  about  $P_2$ , and  $lm$  the velocity of  $m$  relative to  $l$ . The lower plate rotates clockwise about  $P_2$ , and slides, relatively to the upper plate, towards the right. If, in Fig. 383,  $P_1C$  be

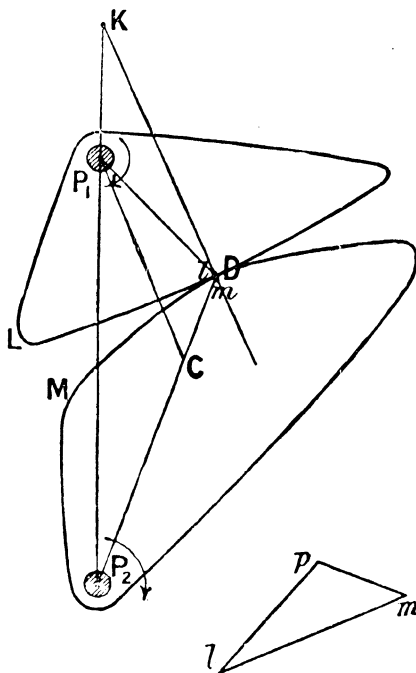

FIG. 383.

FIG. 384.

the lower plate rotates clockwise about  $P_2$ , and slides, relatively to the upper plate, towards the right. If, in Fig. 383,  $P_1C$  be

drawn parallel to the common normal to intersect  $P_2D$  in  $C$ , the triangle  $P_1CD$  is similar to the triangle  $lmp$  (since corresponding sides are perpendicular to each other), and may therefore be looked upon as the triangle of velocities; consequently, if  $P_1D$  represent the velocity of  $l$  about  $P_1$ ,  $CD$  will represent the velocity of  $m$  about  $P_2$ , and  $P_1C$  will represent the velocity of sliding. Or, in other words, if  $\frac{P_1D}{P_1C}$  (that is to say, unity) represent the angular velocity of  $L$  about  $P_1$ ,  $\frac{CD}{P_2D}$  will represent the angular velocity of  $M$  about  $P_2$ ; so that—

$$\frac{\omega_2}{\omega_1} = \frac{CD}{P_2D} = \frac{KP_1}{KP_2}$$

where  $K$  is the point of intersection of the common normal to the two surfaces and the line of centres. If  $K$  lie between the centres, this ratio must be considered negative, indicating that the plates will then rotate in opposite directions about their respective centres. Moreover, the velocity of sliding : the velocity of  $l$  about  $P_1$  ::  $P_1C$  :  $P_1D$ , and therefore—

$$\begin{aligned} \text{Velocity of sliding} &= \omega_1 \cdot P_1C \\ &= \omega_1 KD \cdot \frac{P_1P_2}{P_2K} \\ &= \omega_1 \cdot KD \left(1 - \frac{KP_1}{KP_2}\right) \\ &= \omega_1 \cdot KD \left(1 - \frac{\omega_2}{\omega_1}\right) \\ &= (\omega_1 - \omega_2) \cdot KD \end{aligned}$$

If the plates rotate in opposite directions, the velocity of sliding would be  $(\omega_1 + \omega_2) \cdot KD$ .

A *second method* of obtaining these results is to proceed as follows: Let the centres of curvature of the two curved surfaces,  $L$  and  $M$  (Fig. 385), in the neighbourhood of the point of contact  $D$ , be  $C_1$  and  $C_2$  respectively. For very small displacements, the actual plates may be replaced by circular plates having  $C_1$  and  $C_2$  as centres, and the distance between the points  $C_1$  and  $C_2$  will

be constant. We can, therefore, imagine arms  $P_1C_1$ ,  $P_2C_2$  attached to the two plates and two pins, at  $C_1$  and  $C_2$ , connected by a rigid link without in any way constraining the motion; or, in other words, the motion as transmitted by the two plates is exactly the same as that which would be transmitted by the four-bar chain  $P_1C_1C_2P_2$ . The angular velocity of the first plate will be the same as that of the arm  $P_1C_1$ , and of the second plate the same as that of the arm  $P_2C_2$ ; and therefore, from § 107—

$$\frac{\omega_2}{\omega_1} = \frac{KP_1}{KP_2}$$

as before. It must, of course, be clearly understood that the

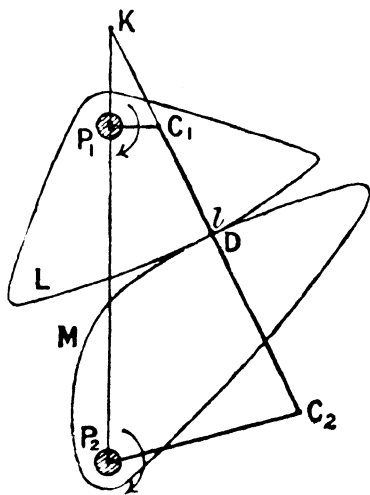

FIG. 385.

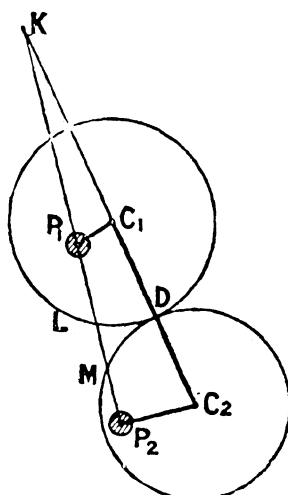

FIG. 386.

equivalent four-bar chain is not the same in all positions, because the centres of curvature  $C_1$  and  $C_2$  vary from point to point; and that, in the general case, it is only for infinitely small displacements that the plates may be connected by a link,  $C_1C_2$ , of invariable length. In one particular case, however, the same four-bar chain may replace the plates in all positions, namely, when the two plates are both circular and rotate eccentrically, as shown in Fig. 386. In that case, for all displacements, finite or small, the

centres  $C_1$  and  $C_2$  may be attached by a rigid link without in any way constraining the motion. In this case the velocity ratio, as transmitted by the circular plates, is independent of the diameter of the plates.

To find the velocity of sliding, the plate  $M$  (and therefore the arm  $P_2C_2$ ) may be imagined fixed, and the link  $P_1P_2$  to rotate *counter-clockwise* about  $P_2$  with the angular velocity  $\omega_2$  (Fig. 385). The relative motions will be unaltered, and the velocity with which  $L$  now slides over the fixed plate  $M$  will be exactly the same as the relative velocity when both plates rotate about their respective centres. The plate  $L$  will now rotate about the moving centre  $P_1$ , and the chain becomes an epicyclic train. The instantaneous centre of  $L$  relative to  $M$  is the same as the instantaneous centre of the link  $P_1C_1$  relative to the link  $P_2C_2$ , and is, therefore, the point  $K$ . Relative to  $M$ , the plate  $L$  is rotating about  $K$  with an angular velocity  $\omega$  (as yet unknown), and the velocity with which the point  $l$  slides over the fixed plate  $M$  is  $\omega \cdot DK$ . To get  $\omega$ , it must be remembered that  $P_1$  is a point in both  $L$  and the link  $P_1P_2$ . Considered as a point in  $P_1P_2$ , its velocity is  $\omega_2 \cdot P_1P_2$ ; considered as a point in  $L$ , its velocity is  $\omega \cdot KP_1$ . Since these are equal—

$$\omega = \omega_2 \cdot \frac{P_1P_2}{KP_1} = \omega_2 \cdot \frac{KP_2 - KP_1}{KP_1} = \omega_2 \left( \frac{\omega_1 - \omega_2}{\omega_2} \right) = \omega_1 - \omega_2$$

so that the velocity of sliding is—

$$(\omega_1 - \omega_2) \cdot DK$$

as before. If the plates rotate in opposite directions,  $\omega_2$  must be considered as negative.

Thus, then, when a motion of rotation is transmitted between two fixed centres by the contact of two curved plates, the angular-velocity ratio is inversely as the segments into which the common normal to the two surfaces at the point of contact subdivides the line of centres; and the relative velocity with which the surfaces slide over each other is equal to the length of the normal, measured from the point of contact to the line of centres, multiplied by the sum or difference of the angular velocities according as the wheels

## NON-CIRCULAR WHEELS.

rotate in opposite or in the same directions—that is to say, according as the point *K* lies between or beyond the two centres.

§ 207. **Special Cases.**—It at once follows that, if the point of contact always lies on the line of centres (Fig. 387), the point *K* always coincides with *D*, so that, since *DK* is then zero, there is no slipping between the plates. The velocity ratio is  $\frac{DP_1}{DP_2}$ , and may, of course, vary from moment to moment; but if the plates be of circular shape, having *P*<sub>1</sub> and *P*<sub>2</sub> as centres, the angular velocity is constant and inversely as the radii of the circles. We thus get the case of two circular pitch surfaces in which the motion is

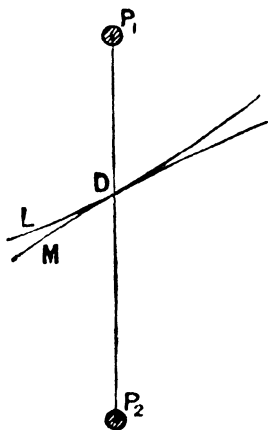

FIG. 387.

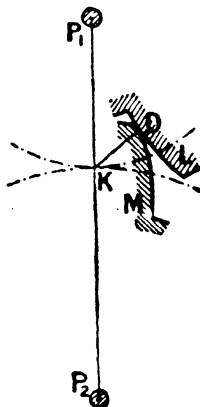

FIG. 388.

transmitted by the frictional resistance to slipping. With non-circular plates, as shown in Fig. 387, the motion is transmitted by direct action.

Again, taking the general case, if the profiles of the plates are such that the common normal at the point of contact always passes through the same point on the line of centres, the angular-velocity ratio is constant. Thus, in Fig. 388, *L* and *M* represent the profiles of the two plates or teeth, and *DK* the common normal at their point of contact. If, for all positions, the common normals pass through the same point *K*, the constant angular-velocity ratio is

$\frac{KP_1}{KP_2}$ , and the motion as transmitted by the plates or teeth is exactly the same as if two pitch circles of radii  $KP_1$  and  $KP_2$  rolled on each other. The velocity with which the plates slide over each other is  $(\omega_1 + \omega_2) \cdot KD$ , and therefore varies as the length of  $KD$ . It is zero when the plates or teeth are in contact at the pitch point  $K$ . The point  $K$ , in fact, is the instantaneous centre of rotation of one wheel relative to the other (§ 112).

§ 208. **Determination of the Shapes of Pulleys which transmit the Same Motion as Two Non-circular Plates.**—The idea of replacing the two curved plates by an equivalent four-bar chain may be extended in the following manner:† As before, let the plates  $L, M$  rotate about the fixed centres  $P_1, P_2$ , and let  $C_1, C_2$  be the centres of curvature of the two plates at their point of contact,  $D$  (Fig. 389). The loci of the centres of curvature of the two plates will be the two curves  $E_1, E_2$  (shown by the broken lines), which are obtained by drawing normals at a number of points in each curve and finding their envelope. The curves  $E_1, E_2$  are the evolutes to the curves  $L, M$ ; or the curves  $L, M$  are the involutes to  $E_1, E_2$ . The curve  $L$  may be derived from  $E_1$  by imagining a

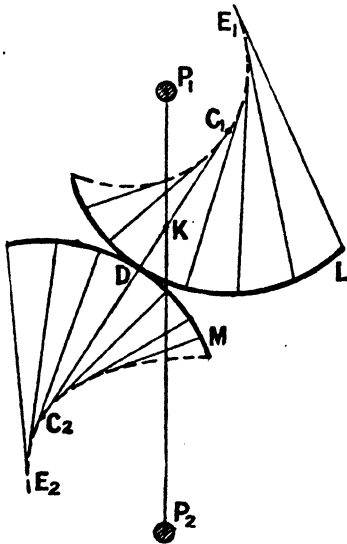

FIG. 389.

string wrapped round  $E_1$ , and attaching a pencil at the point  $D$  in the string. As the string is unwrapped the pencil will trace out the curve  $L$ . In a similar manner, the curve  $M$  may be derived from the curve  $E_2$ . Now imagine the pulleys  $E_1, E_2$  keyed to the shafts  $P_1, P_2$ , so that  $E_1$  rotates with  $L$ , and  $E_2$  with  $M$ ; and let a belt connect the two pulleys, so that as the belt is wrapped on one it is unwrapped from the other. The addition of the pulleys will

† See Willis's "Principles of Mechanism."

in no sense constrain the motion as transmitted by the curved plates, because, in any position, the motion as transmitted by the pulleys will be exactly the same as that transmitted by the plates. In fact, if the plates be removed and the motion entirely transmitted by the pulleys, a pencil attached at the point  $D$  of the string will trace out, on a sheet of cardboard attached to and rotating with  $P_1$ , the curve  $L$ ; and on a card attached to and rotating with  $P_2$ , the curve  $M$ . The pencil will always lie on the common tangent to the evolutes, and will always be the point of contact of the two curves  $L$  and  $M$ . Thus, taking the most general case of the sliding contact of plates, the motion as transmitted by them is exactly the same as that transmitted by the non-circular pulleys, the pulleys being the evolutes of the respective plates. The velocity ratio at any instant is  $\frac{KP_1}{KP_2}$ .

The shapes of the evolutes will depend on the shapes of the plates. If the velocity ratio be constant, the point  $K$ , where the belt cuts the line of centres, must be always the same point. That condition is clearly satisfied (although it is not the only solution) if the pulleys  $E_1, E_2$  are circular with  $P_1, P_2$  as centres. The shapes of the curves  $L$  and  $M$  are then involutes of circles, so that two plates, shaped to involutes of circles rotating about fixed centres, transmit by sliding contact a constant velocity ratio. This is the case already discussed in § 175.

Again, if one evolute be an epicycloid and the other a hypocycloid, the rolling circle in each being the same, their common tangent will always pass through the same point on the line of centres. And since any involute of an epicycloid is a similar epicycloid, and of a hypocycloid a similar hypocycloid,<sup>1</sup> it follows that two plates, one shaped to an epicycloid and the other to a hypocycloid, the rolling circles being the same in each, will by their sliding contact transmit a constant velocity ratio. This is the case already discussed in § 177, but it will be noticed that the method of arriving at the result is quite different to the previous one.

§ 209. Shape of Teeth in Non-circular Wheels.—The two problems

<sup>1</sup> The proof of these statements may be left to the reader.

discussed in §§ 199, 206, namely, the motion transmitted by the rolling contact of non-circular plates, and by the sliding contact of any two plates whatever, exactly correspond to the pitch circles of spur wheels and the teeth which may replace those pitch circles. Taking the general case, the motion transmitted by the sliding contact of any two plates is exactly the same as that transmitted by the rolling contact of two non-circular pitch curves, provided, at every instant, the common normal to the two plates in the first case always passes through the pitch point, or the point of contact of the two pitch curves in the second case. In ordinary spur wheels, the pitch point is always the same point in the line of centres; in the general case, it varies from moment to moment. If the non-circular pitch surfaces are given, the forms which may be given to the teeth in order that the motion transmitted by their sliding contact may be the same as that which would be transmitted by the rolling of the pitch curves, may be determined in exactly the same manner as for the teeth of spur wheels.

Let us suppose that, in addition to the pitch curves A and B (Fig. 390), the shape of the tooth L on the first wheel is given.

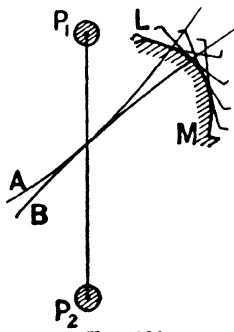

FIG. 390.

To find the tooth on the second wheel to gear with it, imagine the plate A, carrying the tooth L, to roll over B, and trace on the plane of B the successive positions of L: the envelope of these positions will be the proper shape for the tooth M of the second wheel. This is obvious when it is remembered that the teeth L and M will then have a common normal, which will always pass through the point of contact of the rolling plates.

We can also proceed as in § 177, namely, by using a third rolling curve, which rolls inside one of the pitch curves and outside the other. In § 177, the third curve is necessarily a circle, but in the present case its shape depends upon the centre about which it rotates. Thus, in Fig. 391, suppose that A and B are the pitch curves—B being obtained from A by the method of § 200—and let  $P_3$  be a third centre of rotation. The form of the curve C which,

rotating about  $P_3$ , will keep in rolling contact with A and B must be obtained from either of these curves in exactly the same manner as B is determined from A.

When its shape has been determined, attach a pencil to any point D in it, and, as motion takes place, let D describe two curves—one on the plane of A, and the other on the plane of B. These two curves will satisfy the required condition, just as the cycloidal curves in § 177 satisfy the required condition for circular pitch curves. If the third curve is not assumed to rotate about a fixed centre, then *any*-shaped curve may be chosen—in particular a circle. By means of templates

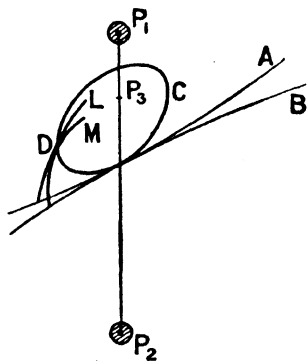

FIG. 391.

the chosen circle may be rolled inside one curve and outside the other, and the loci of any point in its circumference will be curves which may be used for teeth profiles. The teeth will, of course, have figures varying with the curvature of the pitch line. If the teeth are small, the actual pitch curves may be replaced by a number of circular arcs, so that, if the radii of curvature at a number of points can be readily found, the teeth will be cycloidal, as in circular wheels; with the difference that the hypo- and epicycloids will be different in different teeth. The obliquity of the action of the teeth ought not to exceed a certain amount. The angle of obliquity, in non-circular wheels, is made up of two parts, namely, the obliquity of the line of action with the pitch curves, and the obliquity of the pitch curves with the line of centres. Usually, the former does not exceed  $15^\circ$ , and the latter  $35^\circ$ , giving a total of  $50^\circ$ .

Or, again, two suitable curves may be generated in a manner similar to the method adopted for involute teeth in spur wheels. Instead of having the pitch curves given, we may have the two equivalent pulleys ( $E_1$ ,  $E_2$ , § 208)—the pulleys corresponding to the base circles in § 175. The shapes of these pulleys will depend on the law of velocity ratio required; but, having obtained them,

their involutes will be curves which can be used as the profiles of teeth. If, for example, the two pulleys are equal ellipses connected by a crossed belt and rotating about a focus, the equivalent pitch curves are two equal ellipses confocal with the first two ellipses, which touch each other at the point where the two portions of the belt cross each other;<sup>1</sup> so that the involutes of the first two ellipses will serve as teeth for the second two ellipses.

It is not, perhaps, necessary to further enlarge upon the subject of the teeth of non-circular wheels, but sufficient has been said to render clear the principles involved.

§ 210. *Cams*.—Any two plates, such as L and M in Fig. 383, which rotate about fixed centres, and which are not related to any imaginary pitch surfaces, are usually known as cam plates. Usually one of the plates has a motion of continuous rotation, and the other a motion of oscillation or reciprocation. Thus, in Fig. 392, the driver L is keyed to the continuously rotating shaft P<sub>1</sub>, whilst the follower M is keyed to the rocking shaft P<sub>2</sub>. At any instant the velocity ratio between the follower and driver is  $\frac{KP_1}{KP_2}$ ,

K being the point of intersection of the common normal at the point of contact D and the line of centres. The follower is made to perform its upward motion by the direct contact of the driver, but its descent must be brought about either by weighting the arm M, or

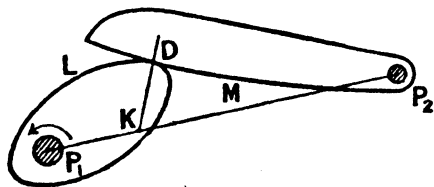

FIG. 392.

by means of springs which keep the two plates in contact. The addition of the weights or springs does not affect the work which the driver has to expend per revolution on the follower.

Very frequently, the follower consists of a rocking arm provided with a circular pin at its extremity, as in Fig. 393. Without in any way altering the motion, the circular pin may be replaced by a cylindrical roller turning about a smaller pin in order to diminish friction. The pin may be made to perform the downward

<sup>1</sup> The proof of the truth of these statements may be left to the reader.

stroke by the force of gravity or by the elasticity of springs, as before; or the cam L may be made to drive in both directions by

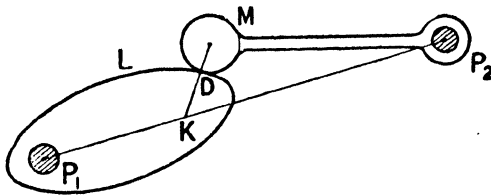

FIG. 393.

making it in the form of a groove of width equal to the diameter of the pin, so that it has two acting edges, as in Fig. 394. The centre of the pin always lies on the centre line of the groove, so that, knowing the form of the centre line, or *pitch line* of the cam,

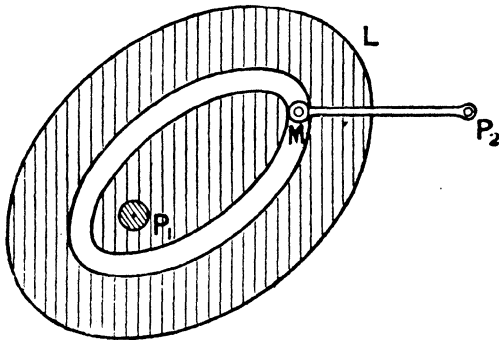

FIG. 394.

as it is termed, the two acting edges may be found by describing a number of circles equal in diameter to the roller, and having their centres on the pitch line of the cam, and then drawing two curves to touch the circles. It ought to be particularly noticed that this is *not* equivalent to joining the centre of the pin with the centre of the shaft  $P_1$ , and marking off along this line distances equal to the pin radius on either side of the centre of the pin.

Instead of the follower oscillating about a fixed centre, it might reciprocate along a straight line, as in Fig. 395; and by using a lobed wheel, as in Fig. 396, the slider may be given any

required number of complete reciprocations for each revolution of the follower. The downward motion of the slider may be obtained by any of the three methods already mentioned; or, if the motion for one half of a revolution of the cam is exactly the reverse of that for the other half, and the line of stroke passes through the

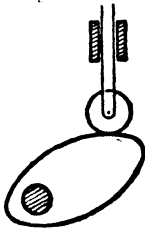

FIG. 395.

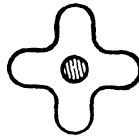

FIG. 396.

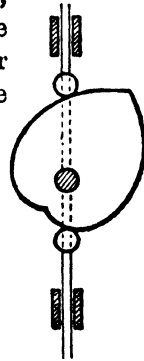

FIG. 397.

centre  $P_1$ , the cam may be made to act in both directions by having two rollers attached to the slider as shown in Fig. 397.

§ 211. **Design of Cams which actuate a Reciprocating Piece, the Slider being provided with a Roller. Examples.**—In designing cams, the problem is either to find the shape of the cam plate of the driver, so that the velocity ratio between it and the follower shall follow a given law; or, more usually, so that the follower shall occupy a series of definite positions corresponding to definite positions of the driver. The solution can almost invariably be found by geometry alone, and the methods to be followed will be best illustrated by a few examples. We shall assume that the driver rotates with uniform angular velocity. Consider, in the first place, those cases in which the follower is a reciprocating piece, and is provided with a roller on which the cam plate acts.

*Case where the Line of Stroke of the Slider passes through the Cam Axis.*—Let the line of stroke of the follower, produced, pass through the axis of rotation of the driver, and suppose that the follower has to move with uniform velocity. Let  $P_1$  (Fig. 398) be the trace of the axis of rotation of the cam,  $A$  the nearest approach of the centre of the roller to  $P_1$ , and  $AB$  the travel of the slider whilst the cam shaft rotates through, say,  $180^\circ$ . Divide  $AB$  into,

say, six equal parts, and from  $P_1$  draw radiating lines inclined at  $30^\circ$  with each other. With  $P_1$  as centre, draw circular arcs through the points of division of  $AB$  to meet the corresponding radiating lines, and through the points of intersection so obtained, draw a smooth curve. That curve will represent the required pitch line, and is clearly—since equal increments in radii correspond to equal increments of angle—an Archimedean spiral. The acting edge of the cam will be a parallel curve to the spiral—obtained by drawing a curve to touch a number of circular arcs of

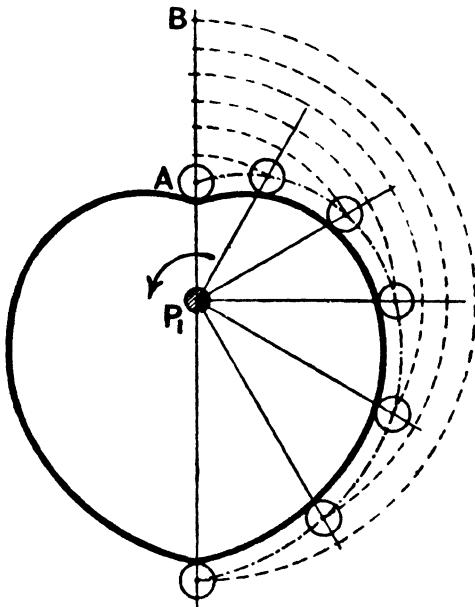

FIG. 398.

radius equal to that of the roller. For, clearly, when the cam shaft turns through  $30^\circ$ , the centre of the roller will be raised through one-sixth of  $AB$ ; when it has turned through  $60^\circ$ , the centre of the roller will be raised through two-sixths; and so on. It will be noticed that the point of contact of the roller and cam plate does not, in general, lie in the line of stroke of the follower. If the return stroke has to take place at a uniform rate, the second

half of the cam must be an exact reflection of the first half, and the complete cam is usually known as the *heart* cam.

In obtaining the pitch line in the manner just described, the principle virtually adopted is to assume the cam shaft fixed and the line of stroke to rotate uniformly round the cam-shaft centre—the slider, in addition to this rotary motion, having its uniform motion of translation. We thus get the successive positions of the slider relative to the cam, and these are the same whether the cam is fixed and the line of stroke rotate, or whether the line of stroke is fixed and the cam rotates. If this idea be thoroughly understood, the most complicated cam motions are rendered comparatively easy.

*Case where the Line of Stroke of the Slider does not pass through the Cam Axis.*—As a second example, suppose that the

reciprocating piece moves uniformly, but that its line of stroke, produced, does not pass through the axis of rotation of the cam. As before, let  $P_1$  (Fig. 399) be the centre of the cam shaft, and  $AB$  the stroke of the reciprocating piece corresponding to a half-revolution of the cam shaft. From  $P_1$  drop the perpendicular  $P_1a$  on the line of stroke produced, and instead of the cam shaft rotating and the line of stroke being fixed in direction, imagine the cam fixed and the right-angled piece  $P_1aAB$  to rotate uniformly round  $P_1$ . With  $P_1$  as

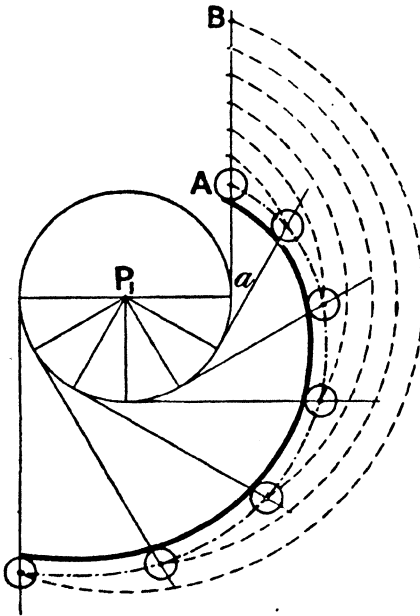

FIG. 399.

centre describe a circle of radius  $P_1a$ , and draw radii inclined at  $30^\circ$ , say, with each other, and at the extremities of these

radii draw tangents; these tangents will represent, relative to the cam, successive positions of the line of stroke. Divide AB into six equal parts, and draw circular arcs having  $P_1$  as centre and passing through the points of subdivision; the points of intersection of these circular arcs with the corresponding tangents will be successive positions of the centre of the roller relative to the cam, and the parallel to the curve joining these points, at a distance from it equal to the radius of the roller, will represent the acting edge of the cam. For as the cam shaft rotates through equal angles in a counter-clockwise direction, the centre of the roller will be pushed through equal distances along the line AB. If the distance AB is equal to the semi-circumference of the circle of radius  $P_1a$ , the pitch line is the involute to that circle.

Precisely the same method may be followed if the slider does not rise uniformly, provided the successive positions of the centre of the roller, corresponding to definite angles turned through by the cam shaft, are known. There are two cases in which the solution is obvious; namely, (1) if the slider is required to remain at rest as the cam shaft rotates through a certain angle, the pitch line corresponding to that angle must be a circular arc having its centre at the axis of the cam shaft; and (2) if the slider is required to drop suddenly through a given distance, the corresponding length of pitch line must be a straight line tangential to the circle of radius  $P_1a$ .

*Numerical Illustration.*—As a quantitative example, suppose a cam is required to satisfy the following conditions, namely: The perpendicular distance of the cam-shaft centre from the line of stroke of the slider to be  $1\frac{1}{4}$ " , the diameter of the shaft  $1\frac{3}{8}$ " , the least width of metal round the shaft  $\frac{3}{4}$ " , and the diameter of the roller  $\frac{1}{2}$ " . As the cam shaft turns through  $60^\circ$  the slider to rise uniformly through  $\frac{3}{4}$ " , as it turns through the next  $150^\circ$  to rise uniformly through the same distance, to remain at rest in its top position whilst the cam shaft rotates through  $90^\circ$  , to then drop suddenly to its initial position, and then to remain at rest for the rest of the revolution.

The solution is shown in Fig. 400, and needs but little

explanation. The vertical line through A is the line of stroke, and A is the lowest position of the centre of the roller. The position of the cam-shaft centre  $P_1$  is known, because the perpendicular distance  $P_1a$  is equal to  $1\frac{1}{4}$ " , and the distance  $P_1A$  is equal to the radius of the cam shaft + least width of metal round shaft + radius of the roller, and is therefore equal to  $1\frac{1}{8}$ ". The angles  $aP_1b$ ,  $bP_1c$ ,  $cP_1d$  are then made respectively equal to  $60^\circ$ .

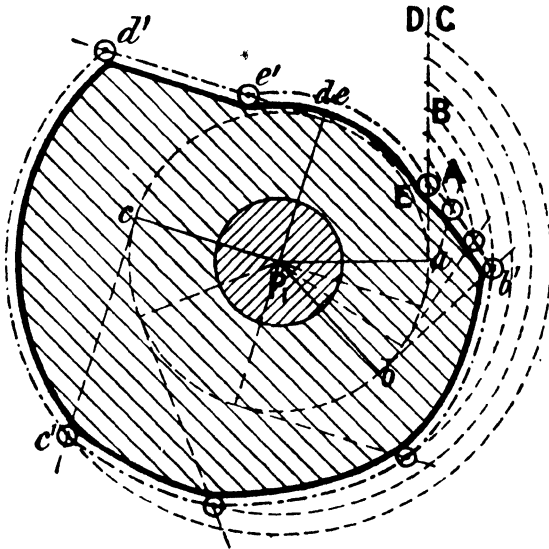

FIG. 400.

$150^\circ$ , and  $90^\circ$ , and the distances  $AB$ ,  $BC$  each equal to  $\frac{3}{4}$ ". As the cam turns through the angle  $aP_1b$ , the slider rises from  $A$  to  $B$ ; as it turns through  $bP_1c$ , the slider rises from  $B$  to  $C$ ; as it turns through  $cP_1d$ , the slider remains at rest; it then suddenly drops to its initial position, in which it remains at rest for the remainder of the revolution. The construction is obvious from what has been already explained. The chain-dot line represents the pitch line, and the thick line the acting edge of the cam distant  $\frac{1}{4}$ " from the pitch line.

*Motion of Slider when the Cam is a Circular Plate turning eccentrically.*—In the three preceding examples the pitch line of

the cam has been obtained which will give to the follower certain assumed motions. Conversely, if the shape of the pitch line is given, the motion or the successive positions of the follower can be determined. The method to be followed is so obvious from what has been already explained that it is not necessary to dwell upon it.

A particular case might, however, be noticed. In Fig. 401, the cam plate is a circle of centre B turning eccentrically about the axis  $P_1$ , which is in the line of stroke, produced, of the follower. The distances  $P_1B$  and AB are clearly constant for all positions of the cam plate, and consequently the motion of the slider is exactly the same as that of the piston of a reciprocating engine (§ 113) having a crank arm equal in length to  $P_1B$  and a connecting-rod equal in length to AB, that is to say, equal in length to the sum of the radii of the cam plate and roller.

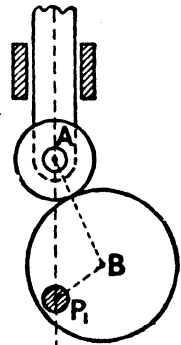

FIG. 401.

§ 212. Cases where the Cam Plate is attached to the Reciprocating Piece, the Oscillating Piece being provided with a Roller.—So far, it has been assumed that the roller is on the reciprocating, and the cam plate on the rotating, piece. In some cases the reverse holds, namely, the roller is at the extremity of a rotating arm, and the cam plate is attached to the reciprocating piece. The most familiar illustration of this is the double-slider crank chain, shown in Fig. 402. Here the acting face of the reciprocating cam is a plane perpendicular to the line of stroke, and by using a slot the roller acts on the upper and lower edge alternately, so that the use of springs in obtaining the return motion is dispensed with. As the crank rotates uniformly, the reciprocating piece moves in a simple harmonic manner.

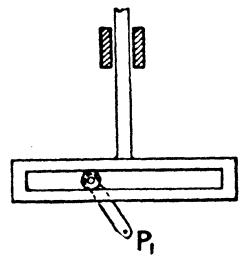

FIG. 402.

By giving different forms to the slot that is to say, to the reciprocating cam, any desired motion may be given to the follower.

If, for example, the reciprocating piece is required to remain at rest, at the top of its stroke, whilst the crank arm rotates through a certain angle, the slot, for a portion of its length, must be of the form of a circular arc having a radius equal to the length of the crank arm, as shown in Fig. 403. At the bottom of its stroke, the reciprocating piece will only be at rest at the moment of reversal. This form is used in sewing machines.

Or, again, the motion of the reciprocating piece may be made

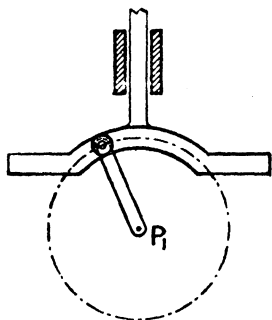

FIG. 403.

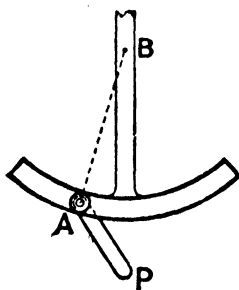

FIG. 404.

exactly the same as that of the piston in the direct-acting engine by making the slot in the shape of a circular arc having centre B (Fig. 404). The motion of the reciprocating piece is clearly the same as if the slot were dispensed with, and the reciprocating piece attached to the pin A by a rod of invariable length equal to the radius of the slot. Thus the mechanisms of the ordinary direct-acting engine, and Figs. 401 and 404, are kinematically equivalent.

The general case, in which the successive positions of the reciprocating piece corresponding to stated positions of the arm are given, need not be discussed; it is only a question of geometry to obtain the proper shape of the slot.

§ 213. **Triangular Cam.**—In dealing with cam motions, the size of the roller is merely a matter of practical convenience—kinematically, it may be of any size. For example, in Fig. 402 the size of the pin or roller may be sufficiently great to embrace the shaft

$P_1$ , as shown in Fig. 405, and the roller may be dispensed with, and the pin keyed directly to the shaft as in the ordinary eccentric. Thus, a circular plate keyed eccentrically, and working between two parallel bars fixed to the reciprocating piece, causes the latter to have a simple harmonic motion.

The reciprocating piece may be made to remain at rest for a certain period at each end of the stroke—the remainder of the motion being simple harmonic—by using a triangular cam whose sides are arcs of circles each described from the opposite angle, the distance between the parallel bars being equal to the radius of the circular arcs forming the sides (Fig. 406). The bars will thus

always be in contact with one angular point and the opposite circle. To follow the motion of the reciprocating piece, divide the dotted circles into six equal parts at the points 1, 2, 3, . . . . As the angle  $a$  moves from 1 to 2, the distance of the lower bar from the centre of rotation  $P_1$  will remain constant, and so the slider will be at rest ; as it moves from 2 to 3, the angle  $b$  will be always

in contact with the lower bar, and therefore the motion is exactly the same as if a pin, placed at  $b$ , acted on the lower bar, and the slider will move harmonically ; as  $a$  moves from 3 to 4, the angle  $a$  will be always in contact with the upper edge, and the motion will again be simple harmonic ;

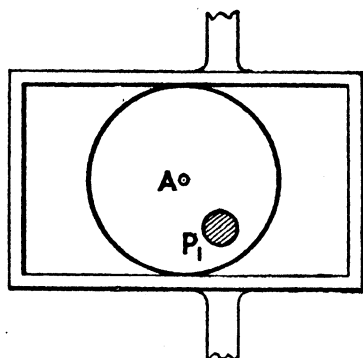

FIG. 405.

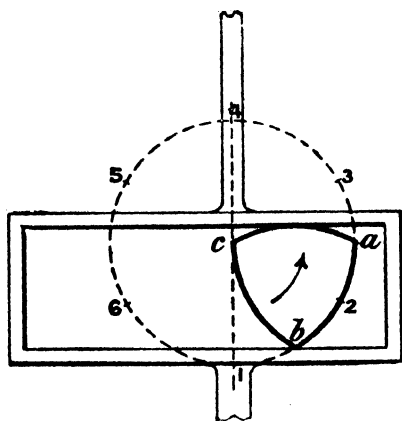

FIG. 406.

similarly, in the return stroke the slider will remain at rest as  $a$  moves from 4 to 5, and will move harmonically as  $a$  moves from 5 to 1.

§ 214. **General Case of a Rotating Cam acting on a Reciprocating Cam provided with a Plane Face.**—In the case of the eccentric (Fig. 405) or triangular cam (Fig. 406), the acting surface of the reciprocating piece is a plane. The most general problem is to find the shape of the cam when the successive positions of the reciprocating piece are known. As an illustration of the method to be followed, let

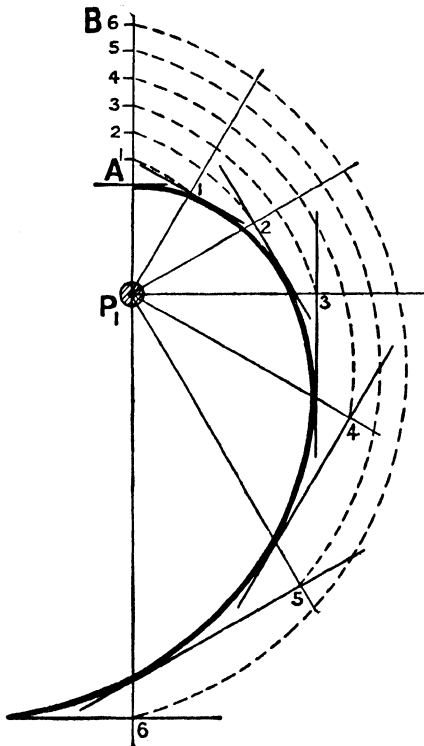

FIG. 407.

it be assumed that the axis of rotation of the cam is in the line of stroke produced, and that as the cam shaft rotates uniformly the reciprocating piece has to rise uniformly. If the acting edge of the follower were a point, the curve for the cam would be an Archimedean spiral (§ 211); but if the acting face be a plane, as in the present case, the acting edge of the cam is obtained in the following way. Instead of the cam rotating, imagine (following the usual method) the reciprocating piece to rotate about the cam centre, and to have, in addition, the uniform radial motion. The relative motion is clearly

unaltered. If, therefore, the reciprocating piece has to rise uniformly from A to B (Fig. 407) whilst the cam shaft rotates uniformly through  $180^\circ$ , divide AB into, say, six equal parts, and draw lines radiating from  $P_1$  inclined at  $30^\circ$  with each

other. Through the points of subdivision of  $AB$  draw circular arcs to intersect the corresponding radiating lines; and through the points of intersection draw lines perpendicular to the radii to represent the successive relative positions of the plane face of the reciprocating piece. The curve drawn to touch or envelope these successive positions will give the proper shape for the rotating cam; for when the cam shaft has turned through  $30^\circ$  in a counter-clockwise direction, the line through the first point of subdivision of  $AB$  perpendicular to the line of stroke will be tangential to the cam plate, and so on. It must be noticed that the point of contact of the plane face and the cam is not in the line of stroke.

§ 215. **General Case of a Rotating Cam acting on an Oscillating Piece provided with a Roller.**—In all the preceding cases the follower has been assumed to reciprocate to and fro along a straight line. Next suppose the follower is an oscillating arm carrying a roller at its extremity (Fig. 393). The most general problem is to determine the shape of the rotating cam so that the follower will occupy definitely stated positions according to the angle turned through by the cam shaft. In Fig. 408, let  $P_1$  be the centre of rotation of the cam, and  $P_2$  the centre of oscillation of the follower; moreover, for each  $30^\circ$  turned through by the driver, let the successive positions of the centre of the roller be denoted by the points

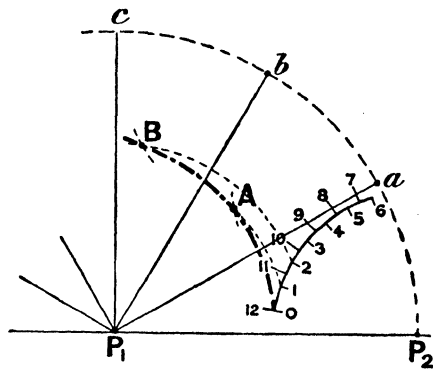

FIG. 408.

0, 1, 2, 3, . . . , the points lying on the arc of a circle having centre  $P_2$  and radius equal to the length of the oscillating arm. Imagine the cam fixed and the line of centres  $P_1P_2$  to rotate about  $P_1$ , so that the successive positions of  $P_2$  are  $a, b, c$ , etc. Clearly one point on the pitch line of the cam is the point  $o$ ; to get a second point, with  $P_1$  as centre draw a circular arc passing through the

point 1 to intersect a circle having centre  $a$  and radius equal to the length of the oscillating arm in  $A$ ; then  $A$  is a second point on the pitch line of the cam, since the triangles  $P_1Aa$ ,  $P_1P_2a$  are equal in all respects, and therefore—the line of centres being supposed fixed—as the cam shaft rotates through the angle  $AP_1P_2$  (which is equal to the angle  $aP_1P_2$ ), the arm will move through the angle  $aP_2P_1$ . Similarly, to get a third point on the pitch line, draw the circle through 2 having centre  $P_1$  to intersect the circle having centre  $b$ , and radius equal to the length of the oscillating arm, in  $B$ ; and so on. The lines joining the points  $o$ ,  $A$ ,  $B$  is the pitch line; and the acting edges of the cam may be found by drawing parallel curves at a distance equal to the radius of the roller.

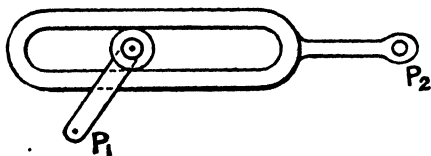

FIG. 409.

Again, the roller may be at the extremity of the rotating arm, and a cam plate attached to an oscillating arm. The most familiar example of this is the crank and slotted lever,

in which the acting face of the follower is a plane (Fig. 409). This case has been fully discussed in § 121.

§ 216. **General Case of a Rotating Cam acting on an Oscillating Cam.**—The most general case of cams rotating about parallel axes is that represented by Fig. 392. If the shape of the oscillating cam plate is known, and its positions for successive stated positions of the driver given, the pitch line of the cam may be found by the method explained in § 211. The cam shaft must be assumed fixed, and the line of centres to rotate round it; and the oscillating cam plate must be plotted in the different positions, just as we plotted the oscillating arm in the previous case. The curve touching or enveloping these successive positions will be the required pitch line of the rotating cam.

§ 217. **Illustrations of Machines using Cam Plates.**—A few illustrations of machines in which cam plates are used may be of interest. One example has already been described, namely, in copying lathes (§ 103). In this, however, the driver does not

act directly on the follower, but through an intermediate sliding piece.

§ 218. **Punching Machines.**—Cam plates are very frequently used for punching and shearing machines. In a punching machine, and to a less degree in a shearing machine, three requirements ought to be satisfied, namely, (1) whilst cutting, the motion of the punch or knife should be slow and uniform; (2) during the return stroke its motion should be quick; and (3) between the end of one stroke and the beginning of the next, the punch or knife should remain stationary for a certain interval, so that time can be given to the workman to place the plate correctly. These conditions can best be satisfied by using cam plates. Fig. 410 shows a single-lever

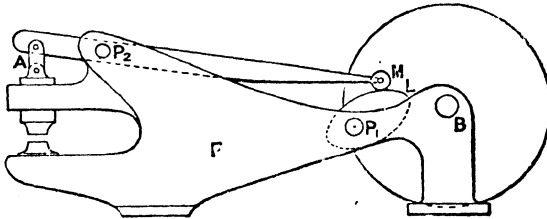

FIG. 410.

punching machine. The frame of the machine is denoted by *F*, the shaft to which the cam plate *L* is attached by *P*<sub>1</sub>, and the centre about which the arm oscillates by *P*<sub>2</sub>. The punch is attached to the lower end of a guide bar, which in turn is connected to the shorter arm of the rocking lever by the link *A*. The longer arm of the lever, which is heavy, carries a roller, *M*, at its extremity, the roller being always in contact with the cam plate *L*. The motion of the shaft *P*<sub>1</sub> is derived from the fly-wheel shaft *B* by gearing. The punch, during the working stroke, cannot be brought to rest without bringing the flywheel to rest, since the driving is positive; consequently the energy stored up in the fly-wheel during the idle stroke is available for punching during the working stroke, and during the return stroke the weight of the longer arm of the lever is sufficient to raise the punch. By giving

the cam a suitable shape, the three requirements already laid down may be satisfied.

§ 219. **Gas-engine Valves.**—A further illustration which may be noticed is the application of cams to actuate the valves of a steam-engine, or the air, gas, exhaust, and timing valves of a gas-engine. Consider, for example, the exhaust valve of a gas-engine. The exhaust valve is invariably of the mushroom or lift type, which is kept pressed on its seat by springs, and which is raised by a cam actuating a lever during the exhaust stroke. The arrangement is shown in Fig. 411. The cam shaft  $P_1$  is driven by gearing from the crank shaft, and rotates at half the speed of the latter. The bell-cranked lever  $AA$  oscillates about the fixed centre  $P_2$ , and is supplied with the roller  $M$  at one end, and actuates the valve  $V$  at the other.

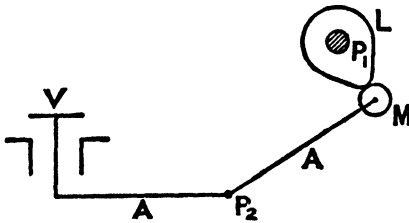

FIG. 411.

In a gas-engine the exhaust takes place every fourth stroke, so that the valve has to be raised one-half of a revo-

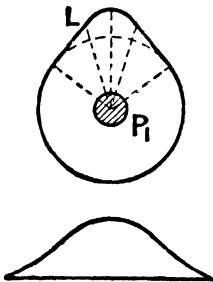

FIG. 412.

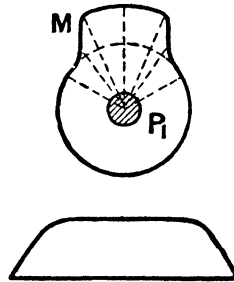

FIG. 413.

lution for every two revolutions of the crank shaft, or one-quarter of a revolution for each revolution of the cam shaft. In practice the exhaust valve opens a little before the end of the working stroke, and the valve has to be lifted for a little more than a quarter turn of the cam shaft. The rapidity with which the valve is opened or closed depends on the form of the cam  $L$ , and if the valve

remains full open for a considerable part of the exhaust stroke, the corresponding arc of the cam must be circular. Fig. 412 shows a slow-opening, and Fig. 413 a quick-opening, valve. The two figures beneath represent the lift of the valve on a cam shaft angle base, the arrangement of levers being assumed as shown in Fig. 411.

§ 220. **Kermode's Steering Gear.**—A fourth example which may be noticed is Kermode's steering gear for ships.<sup>1</sup> To understand the principle of this gear,  $P_1$  (Fig. 414) represents the rudder-head, and  $A$  a spur wheel (driven from the steering engine) which is concentric with  $P_1$ , and rides loosely upon it. In the face of  $A$  is a curved slot,  $L$ , and in this slot a roller or pin,  $M$ , works. The pin  $M$  is constrained to move in a straight line by guides placed transversely in the ship, so that as  $A$  rotates  $M$  receives a certain displacement along this line. If the guide  $L$  is circular and concentric with  $P_1$ ,  $M$  remains stationary; but by giving  $L$  different forms, the displacement of  $M$  may be made to vary according to any required law. In particular, if  $L$  be an Archimedean spiral,  $M$  will advance towards or recede from  $P_1$  through equal distances, as  $A$  rotates through equal angles. The rudder-head  $R$ , keyed to the shaft  $P_1$ , is actuated from  $M$  by the connecting-rod  $C$ , and by suitably shaping  $L$  the angular-velocity ratio between  $R$  and  $A$  may be varied according to requirement, being less the greater the helm angle (see § 152).

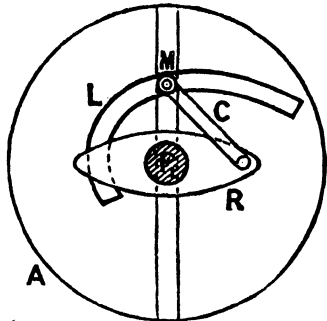

FIG. 414.

In practice the pin  $M$  is attached to a block which slides in the transverse slot, and also turns in an upper block which slides in the groove  $L$ . Moreover, the connecting-rod is not attached directly to the upper block, but to a sliding frame, the block being attached to the sliding frame by springs. These springs allow the helm to move either way when struck by a wave, and

<sup>1</sup> *Engineering*, July 23, 1897.

then cause it to return to its initial position. The guides and connecting-rods are made in duplicate. The pressure exerted by the blocks on the groove is almost normal, so that any shock due to wave-action is not transmitted to the gearing. Further particulars will be found in the article already quoted.

§ 221. **Indicator Rig.**—As a final illustration, consider a suggested indicator rig<sup>1</sup> for high-speed engines (see § 97). An inclined plate, *M* (Fig. 415), is fixed to the side of the engine crosshead, and a lever, *L*, is pivoted to a pin fixed in the crosshead guide. One end of this lever is connected by a link to a plunger working in a tube, *t*, and the other end has a curved surface which engages with the inclined plate. The plunger has, at its upper end, a small crosshead working in a slot in the tube *t*; this crosshead has at one end a hook for taking the indicator cord, and at the other end a thumb-piece. A spiral spring (not shown) is fixed in the upper part of the tube *t*, and exerts an upward pull on the plunger, thus keeping the curved lever in contact with the inclined plate. There is also a spring catch,

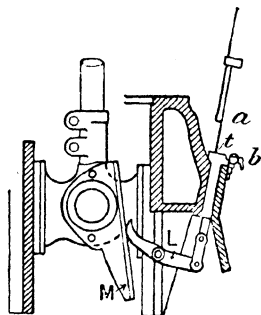

FIG. 415.

*b*, provided with a releasing lever. When it is desired to put the gear out of action, the plunger is pushed down by means of the thumb-piece, until the catch *b* drops into a recess in the plunger. In this position the curved lever is held entirely clear of the inclined plate, and remains so until the catch *b* is released. The gear therefore remains out of action until required, thus facilitating the adjustment of the cords of the indicator, as well as doing away with unnecessary wear.

The problem, from our point of view, is obtain the proper shape of the curve *L*. The displacement of the plunger ought to be exactly proportional to the displacement of the piston, so that the angles turned through by the cam plate *L*, corresponding to successive positions of the piston, are known. To design the plate *L*, follow the method described in § 211; that is to say, assume the

<sup>1</sup> *Engineering*, May 8, 1896



and so on. The points  $a, b', c', d'$  will then represent the relative positions of the crosshead pin and cam shaft—the angular displacement of the cam shaft being proportional to the linear displacement of the piston.<sup>1</sup> The inclined plane  $M$  must then be plotted for each position of the crosshead pin. This is best done by tracing on a piece of tracing-paper the line  $XY$ , the crosshead pin  $a$ , and the plane  $M$ . To find the position of  $M$  corresponding to the second position  $b'$  of the crosshead pin, place the tracing-paper so that the line  $XY$  marked on it is over the line  $2b'$ , and also so that the point  $a$  marked on the paper is over  $b'$ ; and trace through on to the drawing-paper the plane  $M$ . This represents the second position of the plane  $M$  relative to the cam shaft; and this, and subsequent positions, are as shown. The shape of  $L$  is then the envelope of the successive positions of  $M$ .

<sup>1</sup> In Fig. 415, when the piston rises the cam shaft rotates clockwise; consequently, if the cam shaft be assumed fixed, the guides must rotate counter-clockwise about  $P_1$ . This is why the lines  $P_12, P_13$ , etc., are drawn below the horizontal  $P_11$ .

## CHAPTER IX.

### *SPECIAL KINEMATIC CHAINS.*

§ 222. **Freedom and Constraint of a Point.**<sup>1</sup>—A free point has *three* degrees of freedom, inasmuch as the most general displacement which it can take is resolvable into three, parallel respectively to any three directions, and independent of each other. It is generally convenient to choose these three directions of resolution at right angles to one another.

If the point be constrained to remain always on a given surface, *one* degree of constraint is introduced, or there are left but *two* degrees of freedom. For the normal to the surface may be taken as one of three rectangular directions of resolution. No displacement can be effected parallel to it; and the other two displacements, at right angles to each other, in the tangent plane to the surface, are independent.

If the point be constrained to remain on *each* of two surfaces, it loses *two* degrees of freedom, and there is left but one. In fact, it is constrained to remain on the curve which is common to both surfaces, and along a curve there is at each point but one direction of displacement.

§ 223. **Freedom and Constraint of a Rigid Body.**—Taking next the case of a free rigid body, there are evidently *six* degrees of freedom to consider—*three* independent translations in rectangular directions as a point has, and three independent rotations about three mutually rectangular axes.

If it has one point fixed, it loses *three* degrees of freedom; in fact, it has now only the rotations just mentioned.

If a second point be fixed, the body loses *two* more degrees of

<sup>1</sup> Thomson and Tait's "Natural Philosophy," pp. 150-156, by kind permission of Lord Kelvin and the University Press, Cambridge.

freedom, and keeps only one freedom to rotate about the line joining the two fixed points.

If a third point, not in a line with the other two, be fixed, the body is fixed.

If a rigid body is forced to touch a smooth surface, *one* degree of freedom is lost; there remain *five*, two displacements parallel to the tangent plane to the surface, and three rotations. As a degree of freedom is lost by a constraint of the body to touch a smooth surface, *six* such conditions completely determine the position of the body. Thus if six points on the barrel and stock of a rifle rest on six convex portions of the surface of a fixed rigid body, the rifle may be placed and replaced any number of times, in precisely the same position, and always left quite free to recoil when fired, for the purpose of testing its accuracy.

A fixed V under the barrel near the muzzle, and another under the swell of the stock close in front of the trigger-guard, give four of the contacts, bearing the weight of the rifle. A fifth (the one to be broken by the recoil) is supplied by a nearly vertical fixed plane close behind the second V, to be touched by the trigger-guard, the rifle being pressed forward in its V's as far as this obstruction allows it to go. This contact may be dispensed with and nothing sensible of accuracy lost, by having a mark on the second V, and a corresponding mark on barrel or stock, and sliding the barrel backwards or forwards in the V's till the two marks are, as nearly as can be judged by eye, in the same plane perpendicular to the barrel's axis. The sixth contact may be dispensed with by adjusting two marks on the heel and toe of the butt to be as nearly as need be in one vertical plane judged by aid of a plummet. This method requires less of costly apparatus, and is no doubt more accurate and trustworthy, and more quickly and easily executed, than the ordinary method of clamping the rifle in a massive metal cradle set on a heavy mechanical slide.

*Geometrical Clamp.* — A geometrical clamp is a means of applying and maintaining six mutual pressures between two bodies touching one another at six points.

*Geometrical Slide.*—A “geometrical slide” is any arrangement to apply five degrees of constraint, and leave one degree of freedom to the relative motion of two rigid bodies by keeping them pressed together at just five points of their surfaces.

*Examples of Geometrical Slide.*—Ex. 1. The transit instrument would be an instance if one end of one pivot, made slightly convex, were pressed against a fixed vertical end-plate, by a spring pushing at the other end of the axis. The other four guiding points are the points, or small areas, of contact of the pivots on the Y's.

Ex. 2. Let two rounded ends of legs of a three-legged stool rest in a straight, smooth, V-shaped slot, and the third on a smooth horizontal plane. Gravity maintains positive determinate pressures on the five bearing points; and there is a determinate distribution and amount of friction to be overcome, to produce the rectilinear translational motion thus accurately provided for.

*Example of Geometrical Clamp.*—Ex. 3. Let only one of the feet rest in a V slot, and let another rest in a trihedral hollow in line with the slot, the third still resting on a horizontal plane. There are thus six bearing points, one on the horizontal plane; two on the sides of the slot, and three on the sides of the trihedral hollow; and the stool is fixed in a determinate position as long as all these six contacts are unbroken. Substitute for gravity a spring, or a screw and nut (of not infinitely rigid material), binding the stool to the rigid body to which these six planes belong. Thus a “geometrical clamp” clamps two bodies together with perfect firmness in a perfectly definite position, without the aid of friction (except in the screw, if a screw is used); and in various practical applications gives very readily and conveniently a more securely firm connection by one screw slightly pressed, than a clamp such as those commonly made hitherto by mechanics can give with three strong screws forced to the utmost.

*Example of Geometrical Slide.*—Suppose the slot is not used, and let two feet (instead of only one) rest on the plane, the other still resting in the conical hollow. The number of contacts is thus reduced to five (three in the hollow and two on the plane), and instead of a “clamp” we have again a slide. This form of slide—a three-legged stool with two feet resting on a plane and one in

a hollow—will be found very useful in a large variety of applications, in which motion about an axis is desired when a material axis is not conveniently attainable. The movement may be made very frictionless when the plane is horizontal, by weighting the movable body so that its centre of gravity is very nearly over the foot that rests in the hollow. One or two guard feet, not to touch the plane except in case of accident, ought to be added to give a broad enough base for safety.

An old form of the geometrical clamp, with the six pressures produced by gravity, is the three V grooves on a stone slab bearing the three legs of an astronomical or magnetic instrument. It is not generally, however, so “well-conditioned” as the trihedral hole, the V groove, and the horizontal plane contact, described above.

If one point be constrained to remain in a curve, there remain four degrees of freedom.

If two points be constrained to remain in given curves, there are four degrees of constraint, and we have left two degrees of freedom. One of these may be regarded as being a simple rotation about the line joining the constrained points, a motion which, it is clear, the body is free to receive. It may be shown that the other possible motion is of the most general character for one degree of freedom; that is to say, translation and rotation in any fixed proportions as of the nut of a screw.

If one line of a rigid system be constrained to remain parallel to itself, as, for instance, if the body be a three-legged stool standing on a perfectly smooth board fixed to a common window, sliding in its frame with perfect freedom, there remain *three* translations and one rotation.

#### § 224. One Degree of Constraint of the most General Character.—

One degree of constraint, of the most general character, is not producible by constraining one point of the body to a curve surface; but it consists in stopping one line of the body from longitudinal motion, except accompanied by rotation round this line, in fixed proportion to the longitudinal motion, and leaving unimpeded every other motion: that is to say, free rotation about any axis perpendicular to this line (two degrees of freedom); and

translation in any direction perpendicular to the same line (two degrees of freedom). These four, with the one degree of freedom to screw, constitute the five degrees of freedom, which, with one degree of constraint, make up the six elements. Remark that it is only in case (b) below that there is any point of the body which cannot move in every direction.

*Mechanical Illustration.*—Let a screw be cut on one shaft,  $P_1$ , of a Hooke's joint (Fig. 217), and let the other shaft be joined to a fixed shaft,  $P_2$ , by a second Hooke's joint. A nut (not shown) turning on  $P_1$ , has the most general kind of motion admitted by one degree of constraint; or it is subjected to just one degree of constraint of the most general character. It has five degrees of freedom; for it may move, first, by screwing on  $A$ , the two Hooke's joints being at rest; second, it may rotate about either axis of the first Hooke's joint, or any axis in their plane (two more degrees of freedom: being freedom to rotate about two axes through one point); third, it may, by the two Hooke's joints, each bending, have irrotational translation in any direction perpendicular to the link  $C$ , which connects the joints (two more degrees of freedom). But it cannot have a translation parallel to the line of the shafts and link without a definite proportion of rotation round this line; nor can it have rotation round this line without a definite proportion of translation parallel to it. The same statements apply to the motion of  $P_1$  if the nut is held fixed; but it is now a fixed axis, not as before a movable one round which the screwing takes place.

No simpler mechanism can be easily imagined for producing one degree of constraint, of the most general kind.

*Particular case (a).*—Step of screw infinite (straight rifling), *i.e.* the nut may slide freely, but cannot turn. Thus the one degree of constraint is, that there shall be no rotation about a certain axis, a fixed axis if we take the case of the nut fixed and  $B$  movable. This is the kind and degree of freedom enjoyed by the outer ring of a gyroscope with its fly-wheel revolving infinitely fast. The outer ring, supposed taken off its stand and held in the hand, cannot revolve about an axis perpendicular to the plane of the inner ring, but it may revolve freely about either of two

axes at right angles to this, namely, the axis of the fly-wheel, and the axis of the inner ring relative to the outer; and it is, of course, perfectly free to translation in any direction.

*Particular case (b).*—Step of the screw = 0. In this case the nut may run round freely, but cannot move along the axis of the shaft. Hence the constraint is simply that the body can have no translation parallel to the line of shafts, but may have every other motion. This is the same as if any point of the body in this line were held to a fixed surface. This constraint may be produced less frictionally by not using a guiding surface, but the link and second Hooke's joint of the present arrangement, the first Hooke's joint being removed, and by pivoting one point of the body in a cup on the end of the link. Otherwise, let the end of the link be a continuous surface, and let a continuous surface of the body press on it, rolling or spinning when required, but not permitted to slide.

§ 225. *Disc-, Globe-, and Cylinder-integrating Machine.*—The kinematic principle for integrating  $ydx$ , which is used in the instruments well known as Morin's dynamometer and Sang's planimeter,<sup>1</sup> involves one element of imperfection. The imperfection consists in the sliding action which the edge wheel or roller is required to take in conjunction with its rolling action, which alone is desirable for exact communication of motion from the disc or cone to the edge roller.

Amsler's polar planimeter, although different in its main features of principle and mode of action from the instruments just referred to, ranks along with them in involving the like imperfection of requiring to have a sidewise sliding action of its edge rolling wheel, besides the desirable rolling action on the surface which imparts to it its revolving motion—a surface which in this case is not a disc or cone, but is the surface of the paper, or any other plane face, on which the map or other plane diagram to be evaluated in area is drawn.

Professor J. Clerk Maxwell succeeded in devising a new form

<sup>1</sup> Sang's Planimeter is very clearly described and figured in a paper by its inventor, in the *Transactions of the Royal Scottish Society of Arts*, vol. iv., January 12, 1832.

of planimeter or integrating machine with a new principle of kinematic action depending on the mutual rolling of two equal spheres, each on the other. In that paper he also offered a suggestion proposing the attainment of the desired conditions of action by the mutual rolling of a cone and cylinder with their axes at right angles.

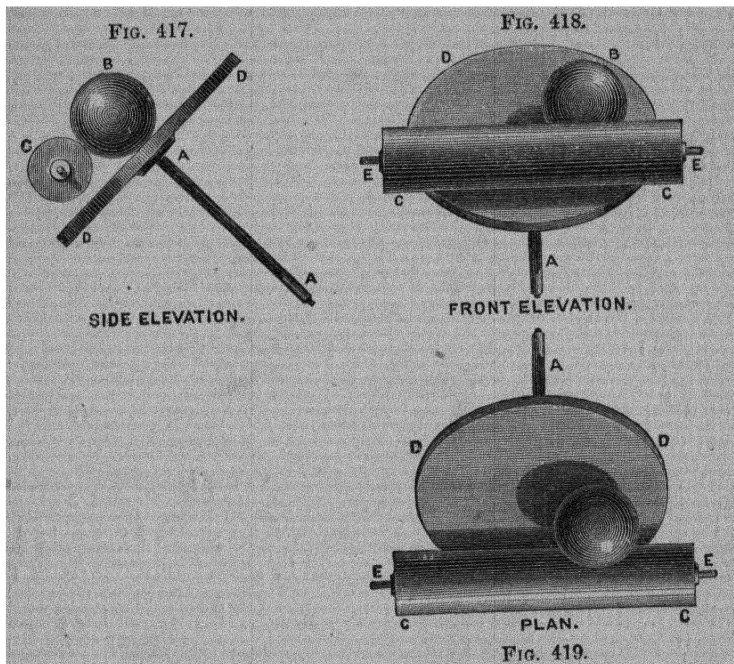

In 1861, Professor James Thomson adopted the principle which consists primarily in the transmission of motion from a disc or cone to a cylinder by the intervention of a loose ball, which presses by its gravity on the disc and cylinder, or on the cone and cylinder, as the case may be, the pressure being sufficient to give the necessary frictional coherence at each point of rolling contact (Figs. 417, 418, 419); and the axis of the disc or cone and that of the cylinder being both held fixed in position by bearings in stationary framework, and the arrangement of these axes being such that when the disc or the cone and the cylinder

are kept steady, or, in other words, without rotation on their axes, the ball can roll along them in contact with both, so that the point of rolling contact between the ball and the cylinder shall traverse a straight line on the cylindric surface parallel necessarily to the axis of the cylinder—and so that, in the case of a disc being used, the point of rolling contact of the ball with the disc shall traverse a straight line passing through the centre of the disc—or that, in case of a cone being used, the line of rolling contact of the ball on the cone shall traverse a straight line on the conical surface, directed necessarily towards the vertex of the cone. It will thus readily be seen that, whether the cylinder and the disc or cone be at rest or revolving on their axes, the two lines of rolling contact of the ball, one on the cylindric surface and the other on the disc or cone, when both considered as lines traced out in space fixed relatively to the framing of the whole instrument, will be two parallel straight lines, and that the line of motion of the ball's centre will be straight and parallel to them. For facilitating explanations, the motion of the centre of the ball along its path parallel to the axis of the cylinder may be called the ball's longitudinal motion.

The longitudinal motion may be imparted to the ball by having the framing of the whole instrument so placed that the lines of longitudinal motion of the two points of contact and of the ball's centre, which are three straight lines mutually parallel, shall be inclined to the horizontal sufficiently to make the ball tend decidedly to descend along the line of its longitudinal motion, and then regulating its motion by an abutting controller, which may have at its point of contact, where it presses on the ball, a plane face perpendicular to the line of the ball's motion. Otherwise the longitudinal motion may, for some cases, preferably be imparted to the ball by having the direction of that motion horizontal, and having two controlling flat faces acting in close contact without tightness at opposite extremities of the ball's diameter, which at any moment is in the line of the ball's motion or is parallel to the axis of the cylinder.

An additional operation, important for some purposes, may be effected by arranging that the machine shall give a continuous

record of the growth of the integral by introducing additional mechanisms suitable for continually describing a curve such that for each point of it the abscissa shall represent the value of  $\alpha$ , and the ordinate shall represent the integral attained from  $\alpha = 0$  forward to that value of  $\alpha$ . This may be effected in practice by having a cylinder axised on the axis of the disc, a roll of paper covering this cylinder's surface, and a straight bar situated parallel to this cylinder's axis and resting with enough of pressure on the surface of the primary registering or *the indicating* cylinder (the one, namely, which is actuated by its contact with the ball) to make it have sufficient frictional coherence with that surface, and by having this bar made to carry a pencil or other tracing point which will mark the desired curve on the secondary registering or *the recording* cylinder. As, from the nature of the apparatus, the axis of the disc and of the secondary registering or recording cylinder ought to be steeply inclined to the horizontal, and as, therefore, this bar, carrying the pencil, would have the line of its length and of its motion alike steeply inclined with that axis, it seems that, to carry out this idea, it may be advisable to have a thread attached to the bar and extending off in the line of the bar to a pulley, passing over the pulley, and having suspended at its other end a weight which will be just sufficient to counteract the tendency of the rod, in virtue of gravity, to glide down along the line of its own slope, so as to leave it perfectly free to be moved up or down by the frictional coherence between itself and the moving surface of the indicating cylinder worked directly by the ball.

In Amsler's planimeter the arrangement is Fig. 420. Here CD, CB are two light arms turning about an axis C, the end B being provided with a pin which is pressed on the paper, and a loaded disc, A, being placed on it to keep it in place. The tracing point is at D, and can be moved in any position. Exactly in the straight line, CD is the axis E, carrying a small wheel, F, whose edge rests on the paper.

When the tracing point D is carried round the outline of any figure such as  $DE_1H$ , so as to return finally to the point from which it started, then, if—

Distance rolled by edge } =  $\frac{\text{area of figure}}{\text{CD}}$   
of wheel F

area of figure = CD  $\times$  distance rolled by the wheel F,

where CD is a measured constant length. The distance rolled by the wheel is measured by a graduated circle and vernier at one side of the wheel, the number of complete revolutions being recorded

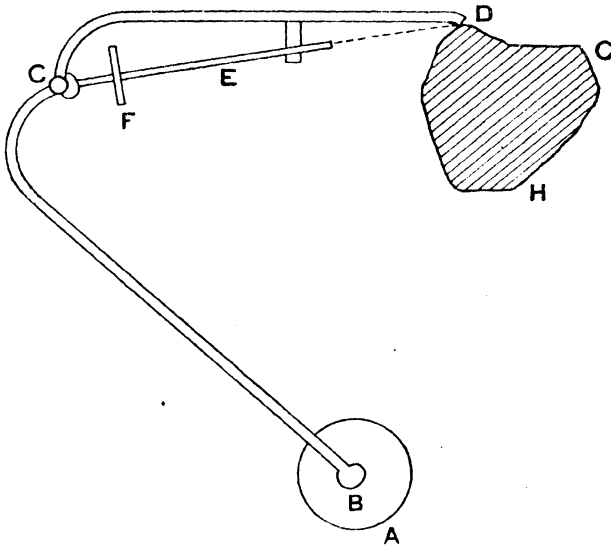

FIG. 420.

by another wheel driven by an endless screw on the shaft. This wheel and screw are omitted in the sketch.

In Fig. 421, BCD is one position of planimeter.

Suppose the roller is placed at, say K, and denote CK by  $k$ . Let the consecutive positions of the mechanism be BCD, BC'D'. Call the arc CC',  $ds$ , and LK,  $ds'$ .

Let  $\theta$  be the angle which CB makes with BX, and  $d\theta$  the small increase in angle, and let  $d\phi$  be the small angle between the lines CD, C'D'.

$$\text{Then } CN = LK - CKd\phi$$

$$ds = ds' - kd\phi$$

$$f ds = f ds' - k f d\phi$$

If  $D$  be girded entirely round the curve,  $\int d\phi = 0$ ; for  $CD$  returns to its original position. Hence the roller describes the same length of curve at whatever point on  $CD$  it be attached. Let it, then, be attached at  $C$ .

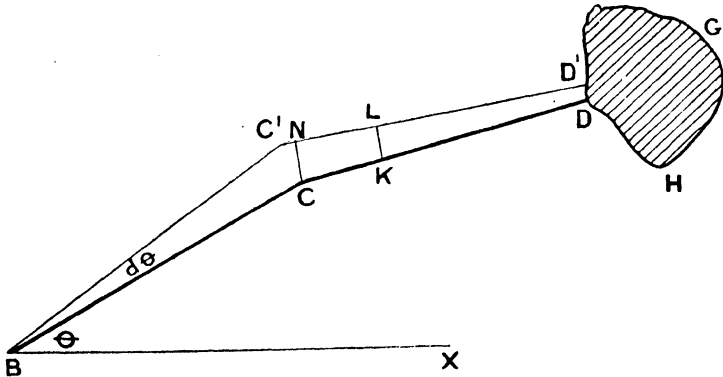

FIG. 421.

Let  $CB$ ,  $CD$  make angles  $\theta$ ,  $\phi$  with  $BX$ , and let them turn through corresponding angles  $d\theta$ ,  $d\phi$ . If  $x$ ,  $y$  be the co-ordinates of the point  $D$ ,

$$\text{area} = \frac{1}{2} \int (x dy - y dx)$$

provided the integration be with respect to  $ds$ .

If  $BC = a$ ,  $CD = b$

$$x = a \cos \theta + b \cos \phi$$

$$y = a \sin \theta + b \sin \phi$$

$$dy = a \cos \theta d\theta + b \cos \phi d\phi$$

$$dx = -a \sin \theta d\theta - b \sin \phi d\phi$$

$$\therefore x dy - y dx = a^2 d\theta + b^2 d\phi + ab(\cos \theta \cos \phi + \sin \theta \sin \phi) d(\theta + \phi)$$

$$= a^2 d\theta + b^2 d\phi + ab \cos(\phi - \theta) d(\phi + \theta)$$

$$= a^2 d\theta + b^2 d\phi + ab \cos(\phi - \theta) d(\phi - \theta)$$

$$+ 2ab \cos(\theta - \phi) d\theta$$

$$\text{Now, } ds = CN = CC' \sin CC'N = ad\theta \cos(\theta - \phi)$$

$$\therefore \text{area} = \frac{a^2}{2} \int d\theta + \frac{b^2}{2} \int d\phi + \frac{ab}{2} \int \cos(\theta - \phi) d(\theta - \phi) + b \int ds$$

If  $D$  go completely round, the first three integrals are each zero, and the area is equal to  $bS$ , when  $S$  is the length of the path

traced out by the roller. Thus, the roller may be placed in any position.

§ 226. **Sarrut's Parallel Motion.**—It has usually been assumed that Peaucellier's parallel motion, discovered in 1864, was the first exact straight-line motion invented. Mr. Bennett,<sup>1</sup> Fellow of Emmanuel College, Cambridge, describes the parallel motion of Sarrut, discovered in 1853, eleven years before Peaucellier's announcement of his cell.

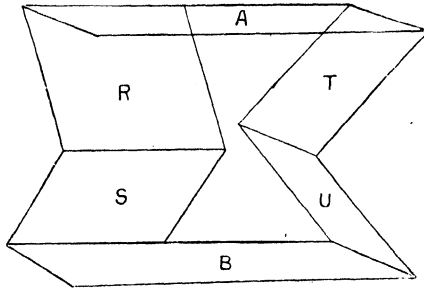

FIG. 422.

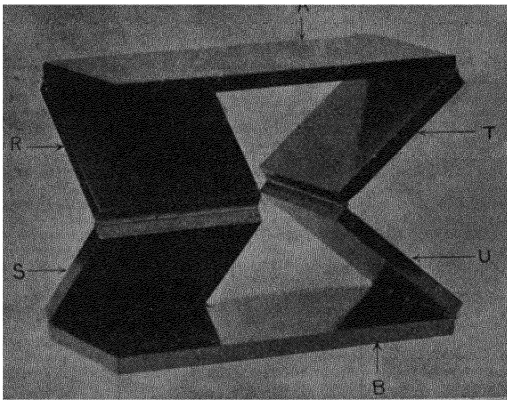

FIG. 423.

The mechanism may be thus briefly described—A moving piece, A, is to have rectilinear motion, say vertically up and down, relatively to a frame or base, B (Figs. 422, 423, 424). To effect

<sup>1</sup> *Philosophical Magazine*, June, 1905.

this, four connecting pieces, RSTU, are used. The pieces ARSB are consecutively hinged by three parallel horizontal hinges;<sup>1</sup> and, again, the pieces ATUB are consecutively hinged by three parallel horizontal hinges, the two directions being different. Connected thus with B, the piece A has a movement which is rectilinear and vertical.

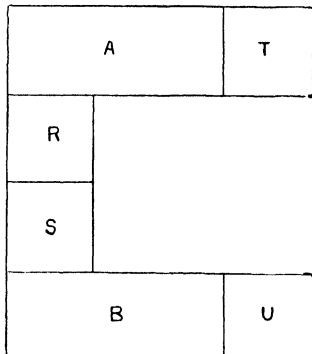

FIG. 424.

The whole forms a closed kinematic chain of six pieces. Seven being the normal number of pieces in a closed kinematic chain necessary to ensure freedom of one degree, it follows that the mechanism of Sarrut belongs to a special class of mechanisms, with only six pieces, possessing singularly and exceptionally one degree of freedom.

It is instructive to compare the mechanism of Sarrut with a certain generalized form. Retaining the same number of pieces and hinges, let it be supposed (Figs. 425, 426, 427) that the hinges consecutively connecting ARSB are concurrent in a finite point X instead of being parallel; and further, that the hinges consecutively connecting ATUB are concurrent in a finite point Y. The piece A has then, relatively to B, a motion of pure rotation about the line XY. Like the Sarrut mechanism, this is a closed

<sup>1</sup> By the term "hinge," here and throughout, is meant, quite generally, any form of connection which ensures a permanent axis of pure rotation for the relative movement of two bodies. "Axis," "turning pair," "cylinder pair," "pivot," "pin-joint," are other terms to be found in use with the same theoretic meaning.

kinematic chain of six pieces singular in possessing one degree of freedom.

Another view of this last mechanism is useful. It may be

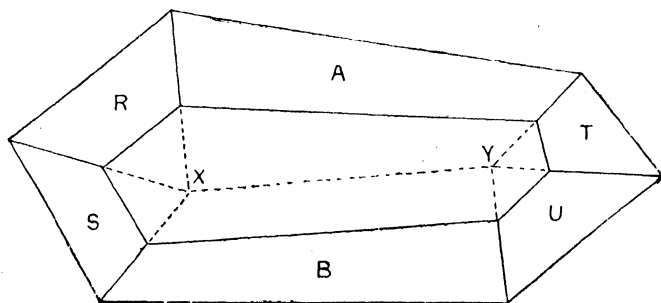

FIG. 425.

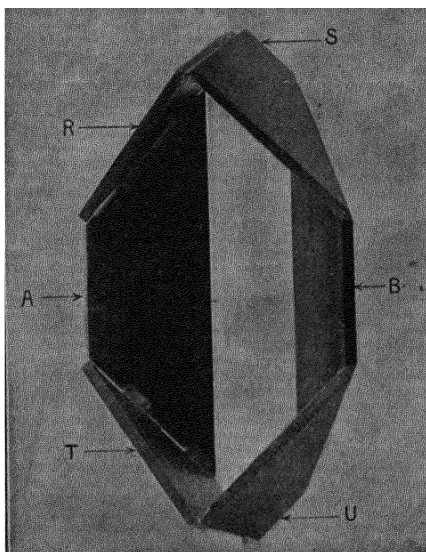

FIG. 426.

regarded as composed of two spherical<sup>1</sup> mechanisms, each of four

<sup>1</sup> The term is perhaps not well enough established to pass without explanation. Mechanisms composed of pieces connected by hinges which are all parallel, being

pieces, placed in tandem with different centres. One consists of a closed chain of four pieces ARSB consecutively hinged along four lines concurrent in X; the other similarly of four pieces ATUB with hinges concurrent in Y; the pieces AB and also

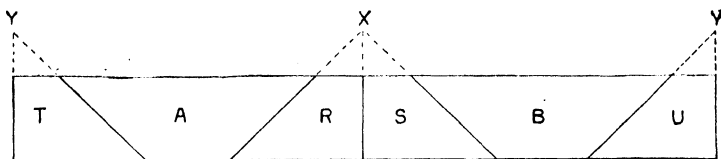

FIG. 427.

their hinge-line XY being common to the two mechanisms. But the singular six-piece mechanism described above arises only after the removal or omission of the hinge XY, which is superfluous or redundant. The line XY is then no longer an actual and mechanical hinge, but yet remains kinematically as a *virtual* hinge-line, in respect of the relative movement of A and B.

This type of mechanism shall be referred to as (a). From the type (a) two special forms are derivable by taking one or both of the points XY at infinity. If one only, say Y, is at infinity, a case (b) is obtained. The three hinges connecting ARSB meet still in a finite point X; but the three hinges connecting ATUB are parallel; and the motion of A relative to B is a movement of pure rotation about a virtual hinge-line parallel to the hinges last named and passing through X (Figs. 428, 429). This mechanism may be regarded as composed of a plane mechanism and a spherical mechanism in tandem, with the common hinge of the two common pieces omitted.

If both X and Y are at infinity a case (c) arises. Each set of

sufficiently represented by any plane section perpendicular to the hinges, are loosely and commonly spoken of as "plane" mechanisms. And by analogy mechanisms of which all the hinge-lines are concurrent in one point, being sufficiently represented by the section in which they are cut by any sphere centred at that point, may be called "spherical" mechanisms. Custom, however, is variable. Reuleaux uses the terms "cylindric" and "conic"; the relative motion of any two pieces being representable by the rolling of cylinder on cylinder in the one case and cone upon cone in the other.

three hinges forms a parallel system; the movement of A relative to B is a rotation about the line at infinity which meets all the

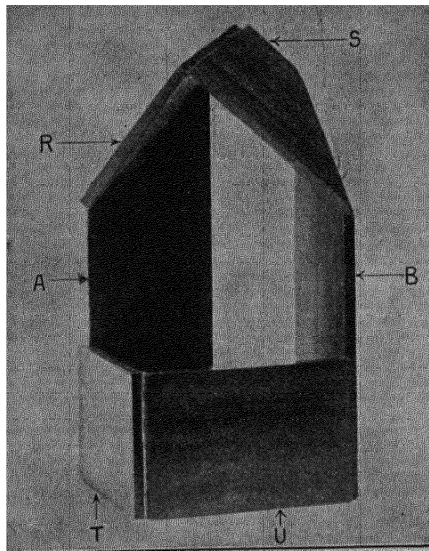

FIG. 428.

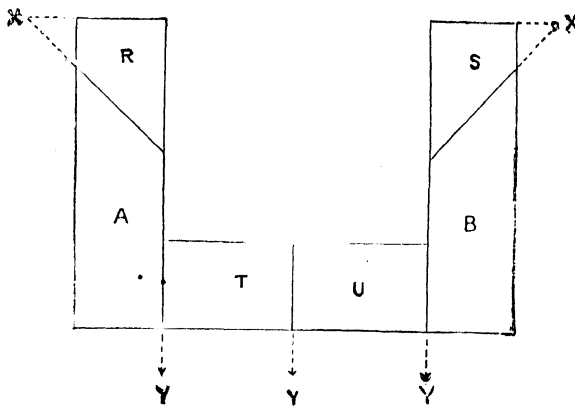

FIG. 429.

hinges, a rectilinear motion therefore in the direction perpendicular to all the hinges. It is the type of mechanism described

by Sarrut. It may be regarded as composed of two plane mechanisms in tandem; these mechanisms having parallel sets of hinges in two different directions and having the virtual common hinge of the two common pieces at infinity. In technical terms the two mechanisms would be called crossed slider-crank chains, having the two sliding pieces in common and the slide-connection itself entirely omitted.

After deriving the mechanisms (b) and (c) from the class (a), Mr. Bennett found that among the collection of models left by Professor Robert Willis occurs a specimen of class (a). It departs

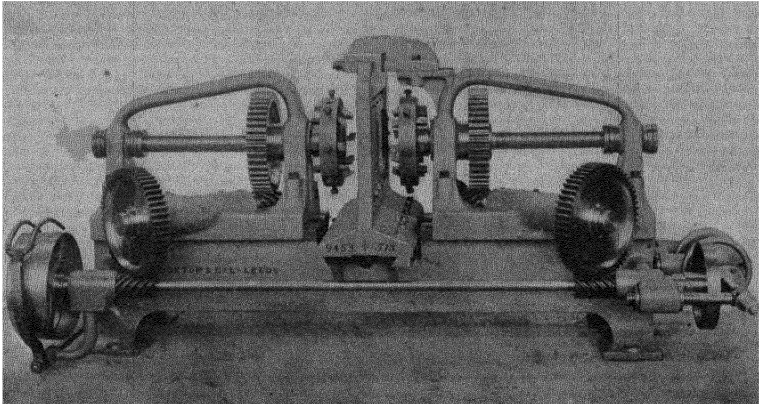

FIG. 430

slightly from generality (see Fig. 425) in that the two hinges connecting the pieces here called RAT intersect each other—a non-essential peculiarity. There is also a specimen which would belong to class (b) if the hinge XY were made virtual instead of actual. Of class (c) there appears to be no specimen. In 1880 a patent (Specification 5492, December 30) was taken out by H. M. Brunel; and in 1891 it was again invented by Professor Archibald Barr (*Proc. Phil. Soc. Glasgow*, March 18, 1891). Yet to this day it appears to remain practically unknown.

§ 227. **Spiral Gear.**—Mr. Wicksteed has kindly supplied me with a description of this interesting gear (Fig. 430). The way

in which Mr. Sellars (in 1876) explained the action of gear was first by comparing it against a quick-threaded worm working into a wheel with oblique teeth—that is, where the axis of the worm was at right angles to the axis of the wheel; and secondly, by comparing it with a pinion rolling into a wheel—that is, where the axis of the pinion was parallel to the axis of the wheel. This spiral gear is between the two, and the spiral pinion converts the spiral motion into a rolling motion, the pressure acting in the direction of transmission. In the absence of the spiral pinion, there would be a dead pressure against the oblique teeth acting at right angles to the direction of transmission, provided the same pitch spiral worm were working on an axis at right angles to the axis of the wheel. Also, in the latter case, the whole force transmitted has to be counteracted by an end thrust bearing on the worm-shaft, whereas, in the case of the spiral pinion, half the force that is transmitted is counteracted by the journals of the shaft.

Messrs. Buckton have adopted this gear in the drive for their planing machine, and in their testing machine.

§ 228. **Universal Horizontal Milling Machine.**<sup>1</sup>—The universal, milling machine (Fig. 431) is so called because in addition to being able to mill a straight surface or surfaces in one direction, the table is arranged to swivel, and is fitted with a dividing head-stock so arranged that any desired combination of lineal and circular motion may be obtained, and a spiral groove of any desired pitch, depth, width, or shape cut. By these means twist drills are grooved, the teeth cut in milling cutters, worm and spiral wheels cut, and, in short, any work which requires a combination of the movements stated. At the same time, the relation between the dividing head-stock and the lineal feed may be disconnected, and the head used solely for dividing purposes, such as grooving taps, cutting small wheels, forming the teeth in clutches, etc.

The machine consists of a strong frame of box section, having the interior arranged as a cupboard for the reception of tools, screw-keys, cutters, etc., and provided with bearing surfaces at the front for the knee bracket supporting the table; the upper portion, above the bearings for the spindle, being designed to

<sup>1</sup> The photograph and description were kindly supplied by Messrs. Hulse, Salford, Manchester.

carry the removable arm for supporting the outer end of the mandrel or arbour for carrying the cutters, and so eliminate

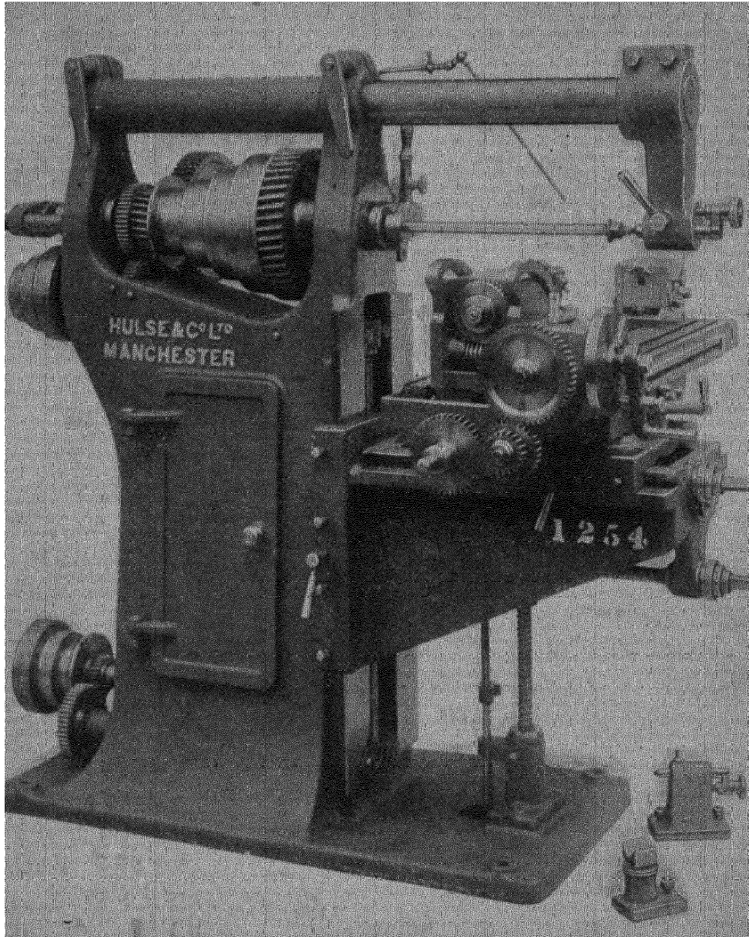

FIG. 431.

spring, which is of all troubles the worst that can befall a miller.

The spindle is made with a conical bearing so as to ensure

accuracy, is bored out with a conical hole for the reception of the cutter mandrel, and is rotated by means of a cone pulley and suitable gearing made with helical teeth to ensure smooth running.

The arm for supporting the outer end of the mandrel may be turned up clear of the spindle when not required, or may be readily withdrawn from its bearings altogether.

The table is arranged to swivel, and is provided with self-acting motion in a lineal direction, driven direct from the spindle and through a shaft passing through the centre of the swivel, thus entirely doing away with the old-fashioned method of applying the feed by means of a telescopic shaft, fitted with universal joints at either end, and attached to the end of the table. A self-acting stop motion is provided, so that the feed may be automatically stopped at any desired point during the traverse. The knee bracket carrying the table may be raised or lowered by means of a screw, operated from the front of the machine, and adjustable stops are fitted so that the work may be examined and the table then brought exactly to its former position.

To ensure a constant supply of lubricant to the cutters, a pump is fitted to the machine, a tank for the storage of the lubricant being also provided.

§ 229. **Worm-gearing.**—The subject of worm contact has been treated at full length by Mr. Robert A. Bruce, M.INST.M.E., in the *Proceedings of the Institution of Mechanical Engineers*, January, 1906. The subjoined matter and diagrams are taken from the paper.

In the case of worm-gearing, the motions of rotation are about axes at right angles, and at the outset some device is required in order to bring the motions within the range of plane diagrams. If attention be confined to any plane section of a worm parallel to its axis, and the worm itself is rotated whilst the plane remains stationary, it is found that the profile of the section remains the same, but changes its position, advancing uniformly in a direction parallel to the axis at a definite rate, one revolution of the worm causing a translation parallel to the axis through a distance equal to the pitch.

Thus Fig. 432 represents a transverse section of a double-threaded right-hand worm, 4 inches outside diameter, 3 inches pitch diameter, 4 inches pitch. The section on a plane through the axis is shown in Fig. 433, the observer being situated on the left of

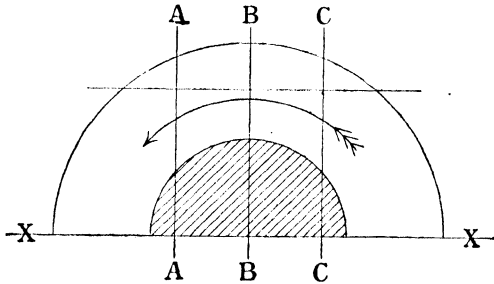

FIG. 432.

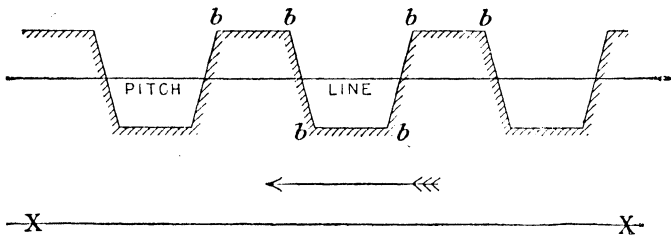

FIG. 433.

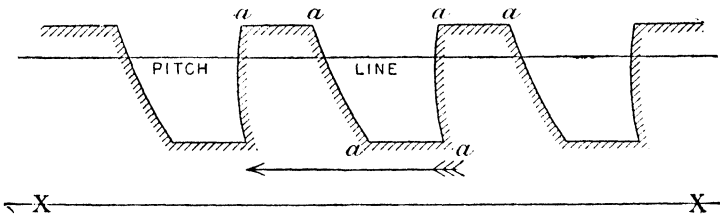

FIG. 434.

BB in Fig. 432. The profile remains unchanged in shape as the worm rotates, but is translated from right to left as shown by the arrow. Fig. 434 is a section by plane AA, the observer being situated in each case to the left of AA in Fig. 432. As the worm rotates, the same constancy of form, combined with a definite rate of translation, occurs.

To study the action of a worm-gearing with a worm-wheel, it is only necessary to choose BB so that it is the plane through the centre of the worm-wheel, and AA will then be a definite plane in the worm-wheel perpendicular to the axis about which it rotates. The tooth-profiles of the worm-wheel in any particular plane, such as BB, must be such that they would correctly gear with a rack of the form *bbb*, in Fig. 433. Similarly, the tooth-profiles of any plane section AA must be such as to gear correctly with a rack *aaaa* (Fig. 434). The plane whose trace is XX must also remain at a constant distance from the axis of rotation. According to this view

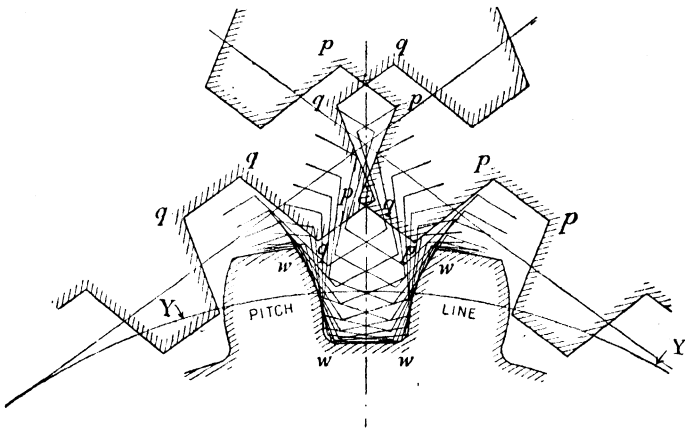

FIG. 435.

any section of a worm-wheel by a plane perpendicular to its axis is the conjugate of a rack whose profile is the section of the mating worm in the same plane. In other words, the profiles of the worm-wheel teeth are the envelopes of all the possible successive positions of the worm-teeth which the latter can assume when working in proper relation to the former. (See Chap. VII.)

In Fig. 435, the statement just enunciated is illustrated, several successive positions of the central section—that is, the section in the plane BB of Fig. 432—of the worm are shown in proper relation to the worm-wheel.

The profile of the worm-wheel is seen to be the envelope of various outlines of the section of the worm-thread. The outline of

the worm-thread, in moving from the position *qqqq* to *pppp*, sweeps out the profile *wwww*, which represents a boundary within which it cannot enter, but every part of which it is forced at some time to touch. The central section of the worm yields a symmetrical profile *bbbb* (Fig. 433), and the conjugate section of the worm-wheel is also symmetrical (Fig. 435). All other sections of the worm by

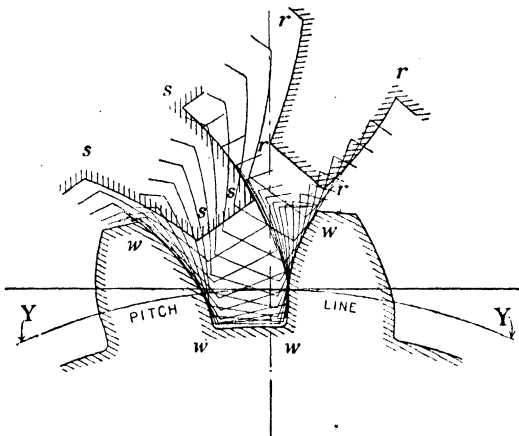

Fig. 436.

planes, such as *AA*, or *CC*, parallel to *BB*, yield unsymmetrical profiles, and the conjugate worm-wheel profiles are also unsymmetrical.

Thus in Fig. 436, *rrrr* represents a section of the worm-thread by the plane *AA* (Fig. 434), in one of its proper positions relatively to the worm-wheel whose pitch line is *YY*; *ssss* also represents the same worm-thread in another possible position, and sufficient intermediate positions of the profile have been drawn to show the unsymmetrical profiles of the worm-wheel teeth, which, as stated before, are merely the envelopes of the successive positions assumed by the section *aaaa* (Fig. 434) of the worm-tooth.

The most general problem is: Given a perfectly formed worm-wheel and its mating worm, what is the nature and extent of the contact that takes place, and how are these affected by the proportions assumed?

In developing the theory which follows, the method of

procedure is to examine what takes place in various planes parallel to the central plane of the worm-wheel. And, as has been already pointed out, the action of the sections of the worm and worm-wheel by such a plane is precisely analogous to gearing together a rack and a wheel. When a rack-tooth is in contact with an engaging wheel-tooth the common normal at the point of contact of the tooth-profiles must pass through the pitch-point or point of contact of the pitch lines. The method has been fully described and illustrated in Chap. VII., and it is unnecessary to add to the explanations there given.

By the method just described, the contact path for any section of a worm parallel to the middle plane can be found, and if an infinite number of such planes be taken, a surface of contact will be obtained. The actual amount of the surface of the worm in contact at any moment is the curved line of intersection of its own surface and the surface of contact. The representation of the surface of contact on a plane can be accomplished by drawing a number of lines of contact by various parallel planes in juxtaposition.

In Fig. 437 the lines of contact are drawn for a worm whose acting face is generated by the line  $aa$ , which rotates and advances along the axis at the rate of 18 inches for one complete turn. The pitch plane is situated 3 inches from the axis and the inclination of  $aa$  to the axis is  $15^\circ$ . The surface generated, therefore, is that of a right-hand worm whose pitch is three times the pitch diameter. The lines  $bb$ ,  $cc$ ,  $dd$ ,  $ee$ ,  $ff$ , and  $gg$ , are sections of the worm surface by planes whose traces are  $AA$ ,  $BB$ ,  $CC$ ,  $DD$ ,  $EE$ ,  $FF$ , and  $GG$ , in the transverse section. The corresponding lines of contact are  $a_1a_1$ ,  $b_1b_1$ ,  $c_1c_1$ ,  $d_1d_1$ ,  $e_1e_1$ ,  $f_1f_1$ , and  $g_1g_1$ , which are the sections of the surface of contact by the planes of section  $AA$ ,  $BB$ , etc. The surface is seen to be twisted. All sections of the contact surface cut the line  $PP$ , whose trace in the longitudinal section is  $p$ . It will be seen that there are no real lines of contact corresponding to sections of the worm surface  $cc$  and  $dd$  by planes  $CC$  and  $DD$ . The dotted line  $d_1d_1$  and  $c_1c_1$  represent imaginary contact lines fulfilling the mathematical conditions of contact only, physical contact being prevented by interference.

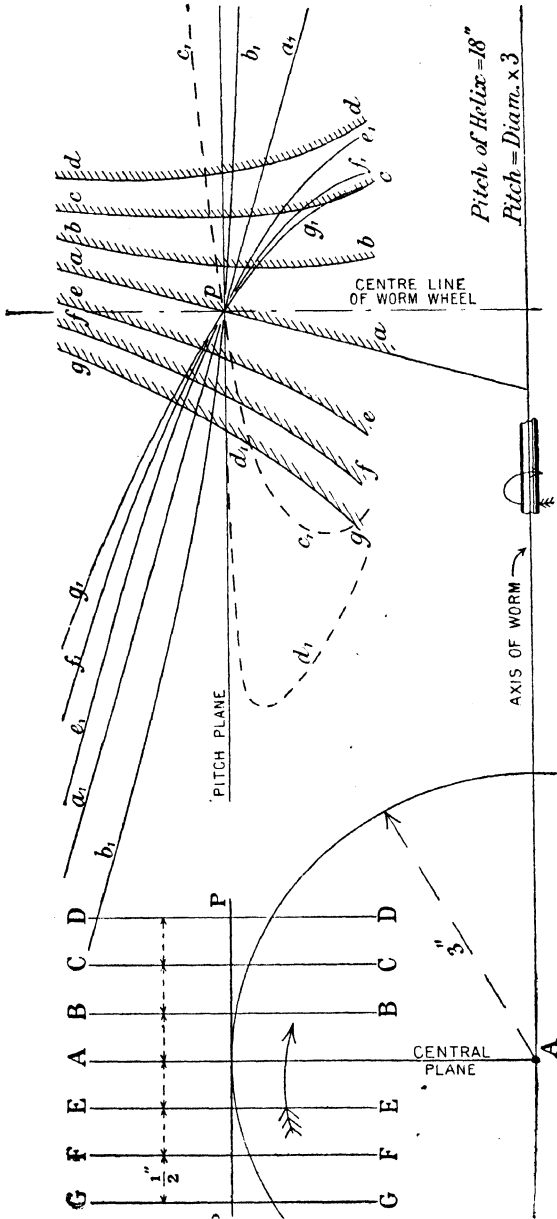

Fig. 437.

The contact surface of the Fig. 437 is typical of the contact surfaces common to all very "steep pitched" worms where the helical angle at the pitch line approaches  $45^\circ$  (the angle in this case being  $43^\circ$  to  $50^\circ$ ). Certain peculiarities should be noticed. The useful or effective portion of the contact surface is much more extended transversely, on the side to the left of AA in the transverse section, or behind the central plane in the longitudinal section. On the other hand, the inclination of the contact line on this side is greater as the distance from the central plane is increased. The inclination of  $g_1g_1$  at the commencement of contact is very marked, whilst that of the line  $b_1b_1$  denotes a considerably reduced obliquity. In Fig. 433 the scheme of lettering is the same as in Fig. 437, the worm represented in this case being one whose pitch is equal to the pitch diameter, the helical angle being  $16^\circ$  to  $42^\circ$ .

Fig. 439 represents the sections of profiles and contact surface of a worm of the same diameter, the pitch being reduced to 2 inches and the helical angle being  $6^\circ 4'$ . The distortion of the contact surface is much less marked, and as the ratio of pitch to pitch diameter (as in Fig. 439) becomes less and less, the tendency of the surface to coincide with an oblique plane whose trace is  $a_1a_1$  becomes greater and greater.

The limitation of the contact surface to the left of AA is not here so apparent, but the tendency towards greater obliquity on that side of the worm which, as it rotates, is advancing towards the central plane is still marked, though not to the extent indicated in Fig. 437. In conjunction with the foregoing remarks, Figs. 437, 438, and 439 sufficiently indicate the general tendency of the surface of contact for any given worm, but the actual amount of contact depends upon the limitations imposed by interference or by the intersections of the surfaces bounding the two gears with the contact surface.

Fig. 440 is drawn to scale to illustrate the actual boundaries of the contact surface in the case of right-hand worm 8 inches diameter, 8 inches pitch (double thread), gearing with a worm-wheel with 30 teeth. The lettering is similar in all three views of the contact surface, the boundary of which is KOK'O—the

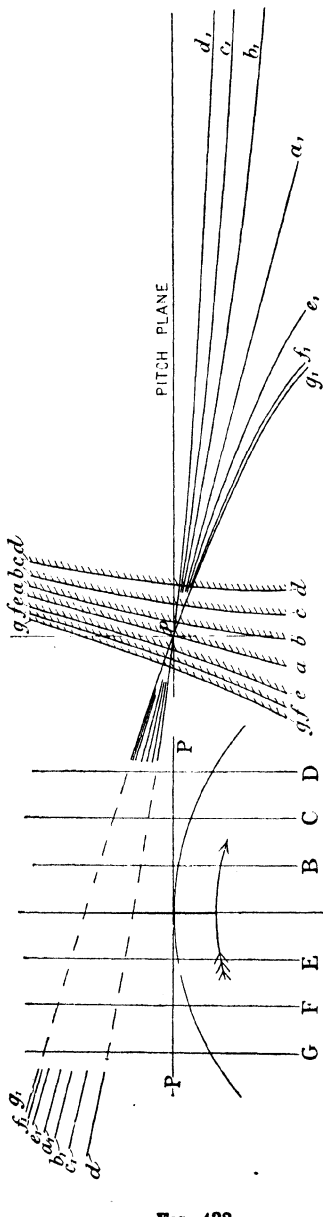

FIG. 438.

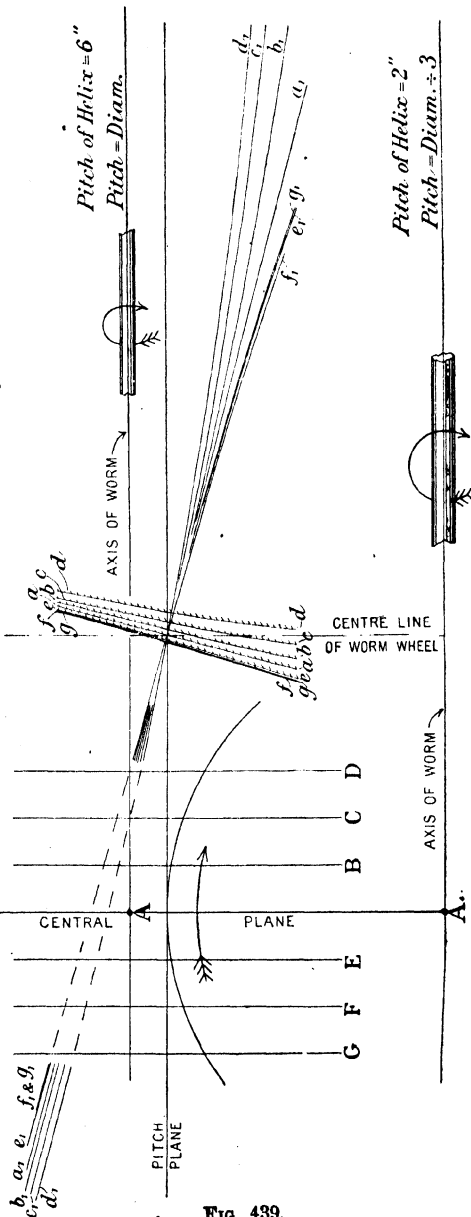

FIG. 439.

dotted lines  $aA$ ,  $a'$ ,  $A'$ , etc., represent lines of contact in planes parallel with the central plane (that is, dividing the worm-wheel symmetrically and containing the axis of the worm). It will be readily seen that the lines of contact are much more extended on the side of the contact surface where the worm-wheel teeth are receding from the central plane (that is, on the lower side in plan), and that the average obliquity of contact is at the same time less on that side. It must not, however, be imagined on this account that the receding side of the contact surface is the more valuable, for in determining the ability of the surfaces in contact to transmit pressure without undue wear or abrasion, it is necessary to consider the mutual forms of the surfaces in contact as well as the length over which contact is maintained. The actual contact at any moment takes place along a curved line which is the intersection of two surfaces, namely, the acting surface of the worm and the surface of contact. Thus, in Fig. 440, the line  $QQ$  in the transverse section of the worm shows the line of contact across the face of the worm at the moment when contact takes place at the pitch point. Mathematically, contact along a line yields no area, but it is scarcely necessary to state that the elasticity of the surfaces and the viscosity of the lubricant in conjunction contribute to expand this ideal line contact into contact over an area on either side of this line.

The relative curvature of the surfaces in contact must therefore be carefully considered, for it is obvious that if they have opposite curvatures, as is the case with surfaces mutually convex, the area of physical contact will be much less than is the case where the curvatures are in the same direction, as happens when a concave touches a convex surface. The influence of the curvature of profiles in contact is illustrated in Figs. 443 and 444, which represent various positions of the profiles of the worm and wheel of Fig. 440, the planes of section being symmetrically chosen with reference to the central plane. The contact along  $dD$  in Fig. 443, though much less extended than that along  $d'D'$  in Fig. 444, is of a kind much more adapted to withstand heavy pressures, the convex profile of the worm-wheel fitting into the concave profile of the worm in Fig. 443, whereas in Fig. 444 the opposite curvatures of

the profile are less suited for retaining the oil-film upon which

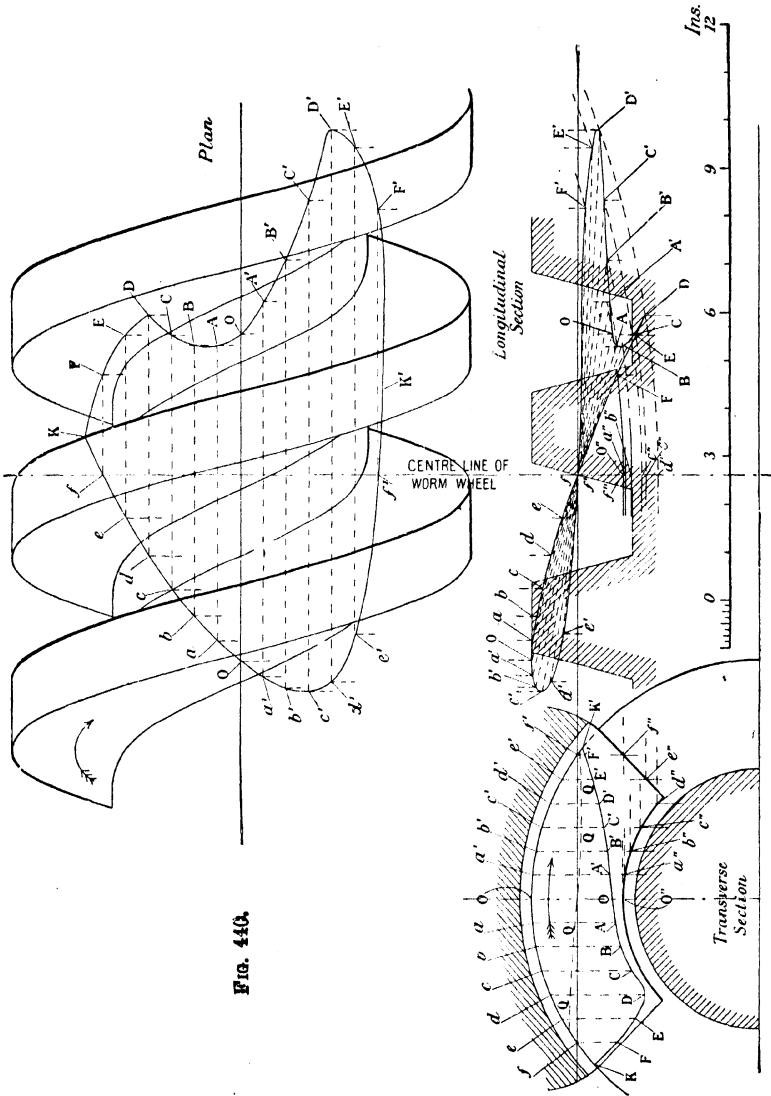

FIG. 440.

FIG. 442.

FIG. 441.

the power of sustaining a load depends. Generally speaking, on the side of the central plane where the worm is advancing the

curvature of the profiles is alike, though the path of contact is less extended, whilst on the side of the central plane where the worm is receding the contact path is more extended, and the curvature of the profiles is unlike. Mr. Bruce, from a mathematical analysis of different cases, comes to the conclusion that for worm-wheel drives of similar general proportions as to height of teeth and arc of worm embraced by the worm-wheel (in transverse section), the average "effective breadth" of the contact line varies very slightly, on account of variations in the ratio of thread-pitch to diameter of worm. On the other hand, the effect of increase in diameter of the worm-wheel has a markedly beneficial effect in this respect, the effective breadth varying as the square root of the diameter of the worm-wheel. The average width of the contact line across the face of the teeth will vary directly as the diameter of the worm, the slight diminution in width when the ratio of thread-pitch to diameter is high being nearly balanced by the tendency towards greater "effective breadth."

To sum up, the area of physical contact varies as the pitch diameter of the worm multiplied by the square root of the diameter of the wheel; or, if the effects of varying the angle subtended by the pitch-line of the worm-wheel at the centre of the worm be considered, it may be said that the effective area of contact varies as the continued product of the diameter of the worm, the tangent of half the angle subtended by the worm-wheel, and the square root of the diameter of the worm-wheel. At any instant the end pressure is shared between several teeth, and it is therefore justifiable to expect a greater power of sustaining loads as the number of teeth in action is greater. The variation in the number of teeth in gear is, however, much more apparent than real. Except in the case of abnormally small worm-wheels, the length of the contact paths on the worm-wheel side of the pitch plane is unaffected by the size of the worm-wheel. On the other side, the contact lines most affected are those which are flattest, or which most nearly coincide with the pitch line. The actual variation in the number of teeth in gear at any one time is found on careful investigation to be small for widely differing sizes of worm-wheel. So that in comparison with other more important matters it may be neglected.

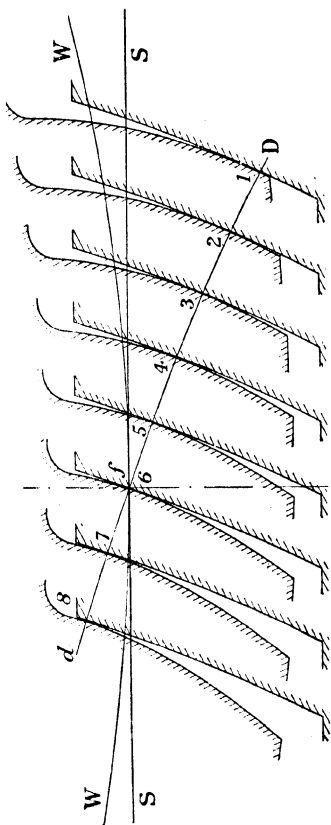

FIG. 413.

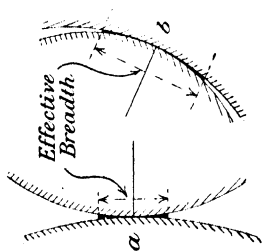

FIG. 415.

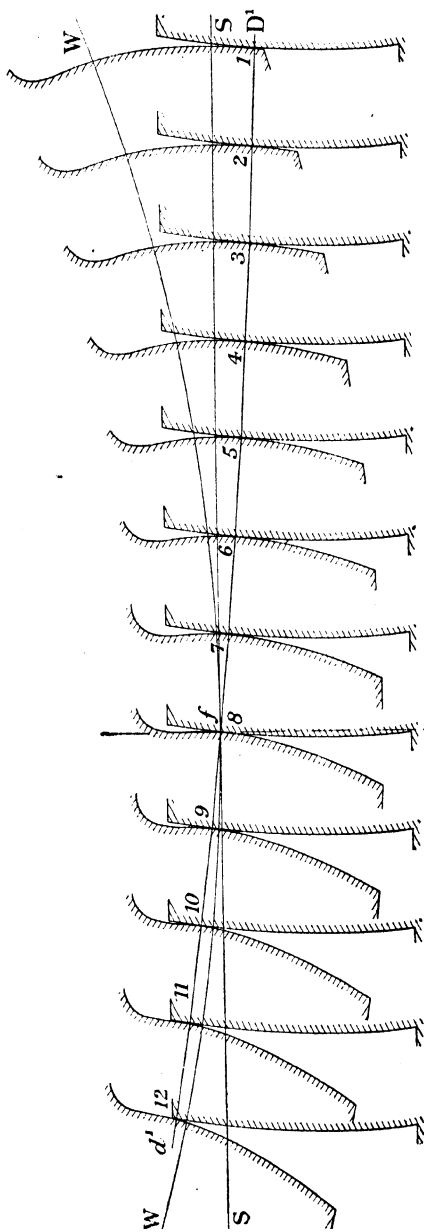

FIG. 444.

By keeping the ratio of the height to the thickness of the teeth as large as practicable, the greatest possible number of teeth are enabled to operate simultaneously, but at the same time, in order to avoid interference, the teeth should be pitched as finely as is compatible with strength and allowance for wear. It should be noticed that in respect of the height of the teeth the dictum given above is in direct opposition to the best practice with spur-gearing, where entirely different conditions are in force.

§ 230. **Four-piece Mechanisms.**<sup>1</sup>—Four-piece mechanisms composed of turning pairs, so far as they are at present known, consist of two familiar species. In the first, the axes of rotation are all parallel to one another, and the mechanism is of the common "cylindric" type. In the second, the axes all meet in a point, and the mechanism is of the well-known "spheric" variety. Any disposition of the axes different from these two special arrangements is known usually to produce a chain of four pieces which is completely stiff, and so furnishes no mechanism at all. But there is an exception to this last rule, which it is the present purpose of the writer to point out—an exception which provides the missing case of a skew mechanism of four pieces having the axes of rotation neither parallel nor concurrent. It appears not to have been noticed hitherto; so that a description of it may be of interest to students of the theory of mechanism, and possibly of use in the more practical field of machine design. It offers the simple means of communicating rotation immediately between two crossing shafts by the use of a single connecting-rod.

*A Skew Linkwork of Four Pieces.*—The essential geometrical features of any one of the links composing a skew mechanism of turning pairs are—

(i.) The angle of inclination of the axes of rotation by which the body is connected with its two neighbours.

(ii.) The length of the shortest distance or common perpendicular between those axes.

In what follows it will be convenient to speak of the angle as the "twist" of the link, and the length of the perpendicular as

<sup>1</sup> By Mr. G. E. Bennett, M.A., Fellow of Emmanuel College, Cambridge. From *Engineering*, December, 1903.

the "length" of the link. The perpendicular itself will be spoken of as the "central axis" of the link, and the axes of rotation at its extremities will be called the "hinge-lines."

The mechanism now to be described consists of four links satisfying the following conditions:—

(i.) Two alternate links have the same length  $a$  and the same twist  $\alpha$ .

(ii.) The other two alternate links have the same length  $b$  and the same twist  $\beta$ .

(It will be convenient to suppose the twists  $\alpha, \beta$  measured in contrary directions—one in the right-handed sense, and the other in the left-handed.)

(iii.) The lengths and twists are made such as to satisfy the relation  $\frac{\sin \alpha}{a} = \frac{\sin \beta}{b}$ .

(iv.) In putting the linkwork together the terminals of the central axes are brought into coincidence, the central axes thus forming a skew quadrilateral with its alternate sides equal.

Fig. 446 shows, in elevation and plan, the purely geometrical or skeleton form of the four links, the duplication of letters on

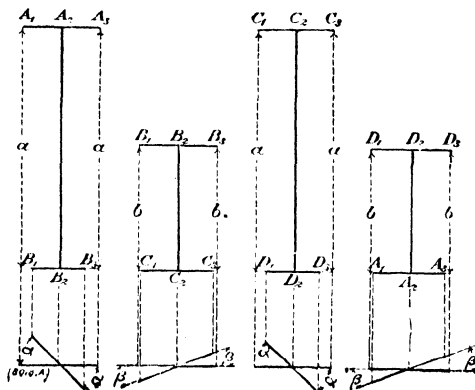

FIG. 446.

the hinge-lines ( $A_1, A_2, A_3$ , etc.) indicating the manner in which they are to be put together. Fig. 447 shows a perspective view of an actual model made to exhibit the completed linkwork.

*The Movement.*—On fixing any one of the four links, regarded then as the frame or bed of the mechanism, and causing an adjacent link to revolve about its fixed axis of rotation as a driver crank, the motion is communicated by the next link, acting

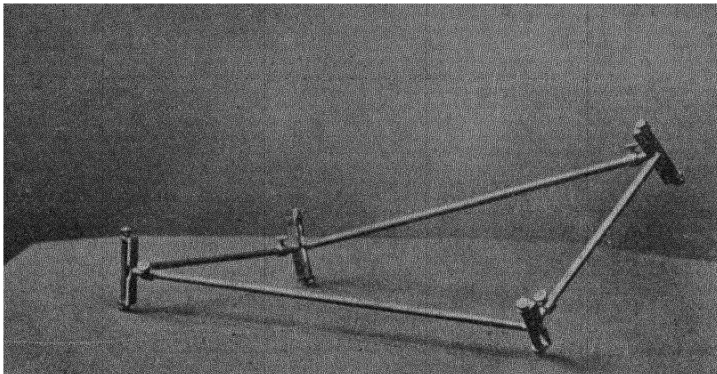

FIG. 447.

as connecting-rod, to the remaining link; and this last revolves, consequently, as a driven crank, turning about its fixed axis of rotation. The angles of rotation of the two cranks are not equal; the relation between them is expressed by the equation—

$$\tan \frac{\theta}{2} \cdot \tan \frac{\phi}{2} = \frac{\cos \frac{1}{2}(\alpha + \beta)}{\cos \frac{1}{2}(\alpha - \beta)}$$

where  $\theta$ ,  $\phi$  are the angles that the central axes of the crank links make with that of the fixed link. (They are the interior angles of the skew quadrilateral of paragraph (iv.) above, of which alternate angles are equal.)

A simple representation of the co-ordinated movements of the cranks may be suggested. Let an ellipse be drawn with its eccentricity  $e$  equal to  $\tan \frac{\alpha}{2} \tan \frac{\beta}{2}$ ; then  $\theta$ ,  $\phi$ , the angles of inclination of focal radii SP, HP to the major axis, have the same relation as the angles of the mechanism (Fig. 448). Thus, if SP be made to revolve in imitation of any movement given to

the driver crank, HP will exactly imitate the movement of the other.

When the point P is at either end of the major axis AA' of the ellipse, the mechanism is in what may be called one of its two zero positions, with all the central axes in one straight line. It

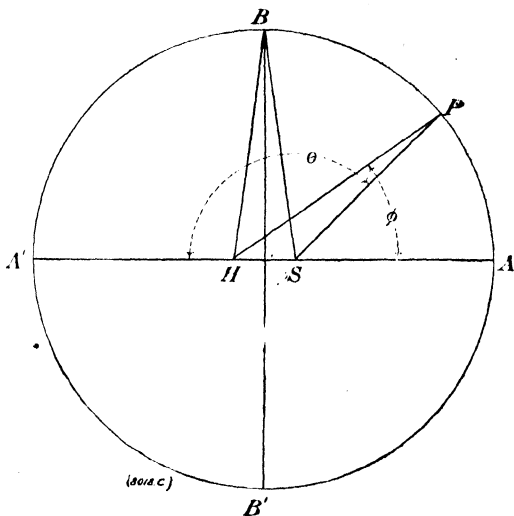

FIG. 448

is in these positions that the angular velocity ratio differs most from unity, being equal to  $\frac{SA}{HA} \left( = \frac{1-e}{1+e} \right)$  when P is at A, and  $\frac{SA'}{HA'} \left( = \frac{1+e}{1-e} \right)$  when P is at A'. When the point P is at either end of the minor axis BB', the mechanism is in what may be called one of its two symmetric positions. It is in these positions that, while the angular inequality is greatest, being equal to angle HBS ( $= 2 \sin^{-1} e$ ), the angular velocities of the cranks are equal. A small value of the inequality corresponds to a small eccentricity of the ellipse, and is secured by arranging that either  $a$  or  $\beta$  shall be small.

*Varieties of Geometrical Form.*—The angles  $\alpha$ ,  $\beta$ , and the lengths  $a$ ,  $b$ , by which the mechanism is geometrically speci-

fied, are subject to only one restriction—that of the equation  $\frac{\sin a}{a} = \frac{\sin \beta}{b}$ ; so that all but one of the four quantities may usually be assigned at will. If, however,  $a$  and  $b$  are assigned,  $a$  being the greater, then  $\beta$  cannot be taken larger than  $\sin^{-1} \frac{b}{a}$ , to which will correspond a unique value of  $a$  equal to  $90^\circ$ . Any smaller value of  $\beta$  allows either of two supplementary values to be given to  $a$ .

If  $a$  and  $\beta$  have values approaching zero, the linkwork approximates to the ordinary plane parallelogram linkwork; and if  $\beta$  approaches zero and  $a$  approaches  $180^\circ$ , the linkwork approximates to the ordinary plane “crossed parallelogram” form.

These two special plane forms appear thus as extreme cases of the skew linkwork here described. The intermediate case in which the twist  $a$  of the longer link  $a$  is equal to a right angle may be regarded as a separating case lying between those skew forms (with  $a$  less than  $90^\circ$ ) which approximate more nearly to the parallelogram form, on the one hand, and those which (with  $a$  greater than  $90^\circ$ ) more resemble the crossed parallelogram form on the other.

In regard to the three possible “inversions” of any form of the mechanism, it is obvious that one is identical with the original, and that the other two give exactly the same movement again, but with interchange of the lengths  $a$ ,  $b$ , and of the angles  $a$ ,  $\beta$ .

Another very special form, worthy of remark, occurs when  $a$  and  $b$  are taken equal, and  $a$  and  $\beta$  supplementary to each other. The representative ellipse then degenerates into a straight line. Each crank in turn revolves through four right angles, while the other remains at rest, the connecting-rod (to use still the same term) moving as one piece with each crank alternately. It may be regarded as a skew form of the “two-ways-hinge” of plane or spheric mechanism.

*Absence of Dead-centre.*—For the two degenerate plane forms of the mechanism the zero positions, in which the central axes fall in one straight line, are at the same time “change-

points" and "dead-centres"—change-points, inasmuch as either form may, on passing the zero position, be converted into the other; and dead-centres, inasmuch as a thrust or pull (the only stress possible) in the connecting-rod produces no turning moment about the fixed axis of rotation of the driven crank. But, for the skew mechanism, the zero positions are neither change-points nor dead-centres. The mechanism has only one mode of movement possible in these positions, as in all others; and a turning moment acting on the driver crank communicates a turning moment to the driven crank. The stress on the connecting-rod which transmits the drive is, it is true, inoperative so far as thrust or pull is concerned, inoperative also as regards twist round its central axis; but the other component stresses affecting the connecting-rod (consisting of two wrenches at its ends, perpendicular to the central axis and the respective hinge-lines) are, it may be shown, more effective in the zero positions than in any other.

*Varieties of Material Form.*—In what precedes regard has been paid to the shape and size of the links only in respect of their geometrical or skeleton form, and not at all in respect of their actual shape and contour. It goes without saying that the precise material form given to the links remains entirely a matter of choice and design. All that is usually said of the possibilities involved in the "alteration" of plane or spheric mechanisms, in regard to variations of form without variation of the essential geometry, applies here with at least equal force. The practical shape given to the design will vary with the purpose of the mechanism.

In Fig. 447 the material closely follows the lines of the skeleton, with the consequence that, though the geometrical features are clearly shown, the links interfere with one another sooner or later, so that only a limited range of movement is possible. In Figs. 449 and 450, on the other hand, though the geometric form appears somewhat disguised, the frame and cranks and connecting-rod are so designed as to allow continuous freedom of movement. To go a step further, it would be a simple matter to design another form (not here shown) in which the geometrical quadrilateral should form no material part of the apparatus at all, but should be found

*A Graphical Construction.*—It may, perhaps, be thought convenient to have a drawing-board construction equivalent to the use of the formulæ connecting the quantities  $a$ ,  $b$ ,  $\alpha$ ,  $\beta$ , and  $e$ . It is supplied by a triangle PQR (Fig. 451), of which PQ, QR are

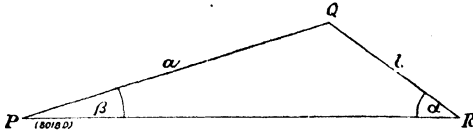

FIG. 451.

equal to  $a$ ,  $b$ , and the opposite angles are equal to  $\alpha$ ,  $\beta$ . The maximum value of the velocity ratio is at once given in the simple form  $(PQ + QR) \div PR$ ; and the ellipse (Fig. 449) is obtainable, if wanted, by making SA, HA equal (or proportional) to PR and  $PQ + QR$ .

## EXAMPLES

*Note.*—The greater part of the numerical results have been obtained with a slide rule.

### CHAPTER I.

1. Verify the formula  $\epsilon = 2p - 4$  in the following cases :—  
Marshall's valve gear (Fig. 239).  
Ollis' steering gear (Fig. 246).  
Stephenson's link motion (Fig. 248).  
Wigzell's engine (Fig. 294).

### CHAPTER II.

2. Motion is transmitted between two parallel shafts by means of belting. The maximum and minimum velocity ratios have to be 7 to 1 and 3 to 1, and the smallest pulley of the speed cone on the faster shaft is 5 inches. The distance between the shafts is 8 feet. Find the diameters of two pairs of pulleys which will give the above velocity ratios (1) when the belt is crossed, (2) when the belt is open.

*Ans.* When crossed : 35", 5" ; 30", 10".  
When open : 35", 5" ; 30·8", 10·2".

3. Sketch (1) a six-fold and (2) a seven-fold purchase, and, calling the velocity of the running block unity, find the velocity of a point in each ply.

4. The diameters of the compound sheave of a differential pulley-block are 8" and 7" respectively. Compare the velocities of haul and lift.

*Ans.* 16.

5. In an oblique-acting tackle (Fig. 45), the cords passing under the running block make angles of  $30^\circ$  and  $60^\circ$  with the horizontal. If the block move vertically, find the velocity ratio of haul to lift.

*Ans.* 1:366.

6. A blower for a portable forge is driven by hand. The hand-driven spindle carries a wheel of 63 teeth, which gears with a wheel of 15 teeth keyed to the same spindle as a single-threaded worm wheel of 90 teeth, and the latter meshes with a worm on the spindle of which is keyed the blower. Find the velocity ratio of hand spindle to blower.

*Ans.* 378.

7. In a crane, the chain barrel is driven by a motor on the spindle of which is keyed a spur wheel of 14 teeth. This gears with a spur wheel of 68 teeth keyed to the same spindle as a spur wheel of 12 teeth. The last wheel gears with a wheel of 50 teeth keyed to the same spindle as a wheel of 25 teeth, and the latter gears with a wheel of 54 teeth keyed to the chain-barrel spindle. The chain barrel is  $16\frac{1}{2}$ " diameter. Sketch the arrangement, and find the revolutions per minute of the motor when 20 feet of chain per minute are wound on the chain barrel.

*Ans.* 202.

8. In the gear for an electrical-driven turret the motor shaft is provided with a single-threaded worm gearing with a worm wheel of  $23\frac{1}{2}$ " diameter, about, and  $1\frac{1}{2}$ " pitch, keyed to a spindle which carries a wheel of 12 teeth which gears with a wheel of  $30\frac{1}{2}$ " diameter, about, and 4" pitch. To the spindle of the latter is a spur wheel of  $14\frac{1}{8}$ " diameter gearing with the circular rack on the turret, and which is  $14' 10''$  diameter. It is found that the shortest and longest times to train the turret through  $270^\circ$  are 52 seconds and 21 minutes respectively. Find the corresponding revolutions per minute of the motor.

*Ans.* Number of teeth in worm wheel, 49.

Number of teeth in spur wheel, 24.

Revs. of motor per minute, 1018 and 42.

9. The quick-return motion for the table of a planing machine is obtained by a screw as shown in Fig. 63. The number of teeth in the bevel wheels G, H, G', and K are 60, 40, 20, and 30 respectively, and the pitch of the screw thread is  $\frac{1}{2}$ ". If the cutting velocity be 10 feet per minute, find the revolutions which the pulleys must make per minute, and also the velocity in the return stroke. Also find the revolutions per minute of M when L is driving, and of L when M is driving.

*Ans.* 360;  $22\frac{1}{2}$  feet per minute.

160; 810 revs. per minute.

10. The quick-return motion for the table of a planing machine is obtained by a rack as shown in Fig. 64. Taking the data given on p. 54, find the

revolutions per minute of *M* during the cutting stroke, and of *L* during the return stroke.

*Ans.* 45.8; 352.

11. The greatest and least diameters of the pulleys of a speed cone for a headstock mandrel are 10" and  $5\frac{1}{2}$ " respectively; and this speed cone is driven from a similar speed cone keyed to a countershaft which makes 250 turns per minute. The back gearing is of the usual type (Fig. 67), the spur wheels concentric with the headstock spindle having 62 and 30 teeth gearing with wheels having 18 and 50 teeth respectively on the back spindle. Find the greatest and least revolutions per minute at which the headstock mandrel may be driven.

*Ans.* 455, 23.9.

12. The leading screw of a lathe is right handed and has three threads to the inch. The largest change wheel of the set has 90 teeth, and the smallest 20 teeth, and the intermediate wheels have 25, 30, 35, etc., teeth. What change wheels would you suggest?—

(1) To cut a right-handed thread of 9 threads to the inch.

(2) " " " 24 " "

(3) " left-handed "  $3\frac{1}{2}$  " "

*Ans.* Values of trains:  $+\frac{1}{3}$ ;  $+\frac{1}{8}$ ;  $-\frac{6}{7}$ .

13. In Q. 12 two equal wheels of 90 teeth placed on the headstock mandrel and leading screw respectively just span the distance between the two shafts. Sketch, to scale (taking the diameters of the wheels proportional to the number of teeth in them), the arrangements suggested.

14. The traverse shaft of a lathe is driven from the headstock mandrel by belting, the greatest and smallest diameters of the speed cones at the extremity of the mandrel being 5" and 2". This drives a similar cone on the traverse shaft, and the worm on the traverse shaft meshes with a single-threaded worm wheel having 40 teeth turning on a stud carried by the saddle. Compound with the worm wheel is a spur wheel having 20 teeth, which meshes with a wheel having 40 teeth keyed to a spindle carried by the saddle. At the front end of this spindle is a spur wheel of 15 teeth meshing with a wheel of 45 teeth, which turns on a stud carried by the apron; and compound with this last wheel is a pinion of 12 teeth which meshes with the rack of  $\frac{1}{2}$ " pitch, attached to the lathe bed. Estimate the greatest and least traverse of the saddle per revolution of the headstock mandrel.

*Ans.*  $\frac{1}{18}$ ";  $\frac{1}{100}$ ".

15. In the feed gear of a drilling machine in which a rack (§ 60) is used to give the traverse of the spindle, the spindle is rotated by a bevel wheel of 18 teeth, keyed on the driving shaft, gearing with one of 32 teeth on the sleeve surrounding the spindle. The greatest and least diameters of the pulleys on the speed cone for the driving shaft are 7" and 4", and this cone drives a similar

speed cone on the horizontal feed shaft. On this shaft is a single-threaded worm which gears with a worm wheel of 45 teeth on the vertical feed shaft. A single-threaded worm on this shaft gears with a wheel of 30 teeth, turning on a horizontal stud, and to which is attached a pinion of 15 teeth gearing with a rack of  $\frac{1}{2}$ " thick, which gives the required feed. Find the least and greatest revolutions of the drill spindle per inch of feed.

*Ans.* 57·9; 177·2.

16. If, in Q. 15, the circumferential speed of the drill when cutting wrought iron is 220 inches per minute, estimate the quickest and slowest times necessary to drill a hole 2" diameter, 1" deep.

*Ans.* 1·65 min.; 5·05 mins.

17. If, in Q. 15, the speed cones on the headstock mandrel and countershaft, as well as the back gearing, have the same dimensions as in Q. 11, and the countershaft rotate at 250 revolutions per minute, estimate the greatest and least revolutions per minute at which the drill spindle can rotate; and the slowest and quickest times for the drill spindle to advance 1".

*Ans.* 256; 13·42 revs.  
13·2; 0·226 mins.

18. The table of a drilling machine is raised by a hand wheel, to the spindle of which is attached a single-threaded worm which meshes with a worm wheel having 40 teeth. Compound with the worm wheel is a spur pinion having 10 teeth of 1" pitch, which meshes with a rack on the frame of the machine. How many turns of the handle are required to raise the table through 2 feet?

*Ans.* 96.

19. The feed motor of a screw drill is as shown in Fig. 83. If the numbers of teeth in the wheels N, Q, R, and P are 30, 31, 25, and 26, and the pitch of the screw thread is  $\frac{1}{4}$ ", find the two linear speeds of advance per revolution of the drill spindle.

*Ans.* 0·0174";  $\frac{1}{8}$ ".

20. In the automatic power chuck illustrated in Fig. 88, the numbers of teeth in the wheels C, D, F, and G are 50, 30, 25, and 40 respectively. The number of exterior threads on G are 10 to the inch, and the number of interior threads on G are 12 to the inch. Find the linear displacement of the collet, (1) when opening, (2) when closing, for each revolution of the mandrel.

*Ans.*  $\frac{1}{60}$ ";  $\frac{1}{1440}$ ".

21. A deck indicator, used to indicate the position of a watertight door, is composed of an epicyclic train as follows: A pinion, B, revolves loosely on a spindle projecting perpendicularly from a disc, A, keyed to the valve spindle. It is deep enough to engage with two annular wheels, C and D, concentric with the valve spindle; one of which, C, is fixed, and has 24 teeth, and the other, D, which is free to revolve and is attached to the indicating plate, has 25 teeth.

How many turns of the valve spindle is needed to turn the indicating plate through  $90^\circ$ ; and will the spindle and plate rotate in the same or opposite directions?

*Ans.*  $6\frac{1}{2}$  turns in same direction.

22. In a reverted train (Fig. 93), the fixed wheel A has 64 teeth, and meshes with a wheel, B, having 35 teeth. Compound with B is a wheel, C, having 36 teeth, which meshes with a wheel, D, having 63 concentric with A. Find the revolutions of D for each revolution of the arm carrying the wheels B and C; and state whether they rotate in the same or opposite directions.

*Ans.*  $\frac{99}{2205} = \frac{1}{22\frac{1}{3}}$ ; in opposite directions.

23. A pulley block for lifting a heavy weight is constructed as follows:—Secured to the block so as not to revolve is an annular wheel, A, of 20 teeth. A second annular wheel, B, of nearly the same diameter, but having one tooth more than A, revolves loosely on a spindle concentric with A, and is bolted to a recessed pulley, having a diameter of 7", round which is led the chain by which the weight is lifted. A spur wheel, C, is mounted so as to turn freely at the extremity of an arm keyed to the spindle. C is deep enough to gear both with A and B. To the spindle is keyed a recessed pulley 10" diameter, around which is led the endless chain for hauling. Determine the velocity ratio of haul to lift.

*Ans.* 30.

24. A wheel, A, having 50 teeth gears externally with a wheel, B, having 80 teeth. The wheel A rides on a stud attached to an arm which turns loosely about the axis of B. If the wheel A move round B, but is prevented from rotating (that is to say, if a line marked on A moves parallel to itself), find the revolutions of B for each revolution of the arm.

*Ans.*  $\frac{13}{8}$ , in same direction as arm.

25. In the horse gear for grinding corn, the bracket that holds the pole supports below it a short horizontal shaft carrying two bevel wheels, one of 40 teeth and another of 30 teeth, both being on the same side of the central vertical axis. The former one gears with a horizontal bevel ring placed above it, having 200 teeth. This wheel is stationary and forms part of the framing. The wheel of 30 teeth gears with a bevel wheel of 20 teeth placed below it, which is loose on the central vertical axis, and to which is attached a bevel wheel of 60 teeth gearing with one of 16 teeth on the high-speed horizontal shaft. Find the revolutions of the high-speed shaft for each circuit of the base.

*Ans.*  $31\frac{7}{8}$  revs.

26. In Humpage's gear (§ 72), the numbers of teeth on the wheels B, C, D, E, and F are 20, 64, 30, 80, and 50. If the high-speed shaft rotate at 400 revolutions per minute, find the number of revolutions of the low-speed shaft.

*Ans.* 20 revs.

## CHAPTER III.

27. Prove the proportions of Tchebicheff's motion given in § 84.

28. Prove the proportions of Roberts' motion given in § 85.

29. In the Grasshopper parallel motion (Fig. 117) the link AB is 5 feet long, the distance AD is 3 feet, and the stroke of the tracing point A is 2 feet—1 foot on either side of the stroke of B. If the tracing point exactly lies in the required straight in the two extreme and mean positions, find, graphically, the position of the centre Q and the length of the lever QD. Plot the locus of A.

*Ans.* Length of lever, 1·15 feet.

30. In a simple Watt's parallel motion, the length of the levers are 2 feet and 3 feet respectively, and the length of the connecting link is  $1\frac{1}{2}$  foot. Find the point in the link which most nearly moves in a straight line, and trace the complete curve described by the point as the levers move into all possible positions, the motion being set so that when the levers are horizontal the coupler is vertical.

*Ans.* 1 foot from the shorter lever.

31. In Watt's parallel motion corrected for obliquity (Fig. 126), the stroke is 1·8 feet, and the distance of the tracing point in its mean position (namely, the distance  $a_1m$  in Fig. 126) is 1 foot below the horizontal line through  $P_2$ ; whilst the distance of  $P_2$  to the right of the line of stroke is 1·3 foot. If the vertical distance between the shafts  $P_1$  and  $P_2$  is 1·52 foot, find the lengths of the two levers and coupler, and the horizontal distance between  $P_1P_2$ .

*Ans.*  $P_2d_1$  = 1·46' approx.  
 $P_1b_1$  = 2·67' "  
 $d_1b_1$  = 1·54' "  
 Horizontal distance = 3·0' "

32. In a beam engine, the stroke of the piston is 6 feet, of the air-pump 3·38 feet; the length of the beam is 18 feet, and the main and back links of the parallel motion are 3 feet long. If the back link is perpendicular to the walking beam and bridle rod in the mean position of the mechanism, find the proper length of the radius rod and the point in the back link where the air-pump rod should be attached.

*Ans.* Length of rod =  $6\frac{1}{2}$  feet about.  
 Point of attachment = 1·69' below beam.

33. In Q. 32, suppose that the parallel motion is set for least deviation from a straight line; find the correct positions of the centre lines of the air-pump and piston, and the position of the centre of motion of the radius rod.

*Ans.* Reckoned horizontally from centre of beam

Distance of line of stroke of piston	=	8.75'	approx.
" " " air-pump	=	4.92'	"
" centre of motion of radius rod	=	11.3'	"

34. In the Thompson indicator (Fig. 137), the link AB is 3", AD = 1.6", AG = 2.16", CG = 0.58"; and the horizontal distance between the line of stroke of C and of A is 2.05". In the highest position, the point C is 0.6", and the point 1.8" above the top of the cap. If the stroke of A is 1.75", plot the mechanism in the two extreme and mean positions, and find the centres Q and R and the lengths of the levers QD and RB.

35. In the Crosby indicator (Fig. 139), CD = 4.51", FD = 0.79", FA = 0.87", AE = 0.25". In the uppermost position, the tracing pencil C is 3.2" from the lowest line on the indicator cap, whilst the corresponding distance of A is 1.43". If the full stroke of the pencil is 2" and of the piston rod  $\frac{1}{2}$ ", plot the mechanism in the extreme and mean positions, and find the lengths of the levers PD and QE, with the positions of the centres P and Q. In these three positions, find the velocity ratio of A to C.

#### CHAPTER IV.

36. In a feathering paddle wheel, the immersion of the centre of the floats is one-eighth the diameter of the wheel, and the proportions of the mechanism are such that the floats in all positions are vertical. Sketch the mechanism, and find the "slip."

*Ans.* 25 %.

37. A paddle wheel, with feathering floats, has a mean diameter of 24 feet. The depth of the floats is 4 feet, and the immersion of their upper edge in the lowest position is 1 foot. If the stem levers are 2.4 feet long, find the position of the centre of the collar to which the guide rods are attached, and also the lengths of the rods, when the slip of the wheel is 20 %.

*Ans.* Length of lever, 12.1 feet.

Distance between centres, 2.2 feet.

38. A reel of cotton is  $\frac{7}{8}$ " diameter, and the enlarged ends are 1" diameter. A length of cotton equal to 14" is unwound and led horizontally from the bottom

point of the reel. If the end of the thread is gently pulled, and the bobbin rolls without slipping, find through what distance the extremity of the thread moves before the bobbin overtakes it.

*Ans.* 2".

39. A plank 10 feet long, rolls over a roller which in turn rolls over the ground. How far will the plank travel in passing over the roller?

*Ans.* 20 feet.

40. A bicycle has wheels 28" diameter, with 7" cranks. It is lightly held so as to stand upright, and the cranks are placed vertically. A gentle force is applied backwards in a horizontal direction at the bottom pedal. In which direction will the bicycle move: (1) if the machine is geared up to, say, 80; (2) if the machine is geared down to 14; (3) if the machine is geared down to, say, 7?

*Ans.* (1) Backwards.  
(2) Remains at rest.  
(3) Forwards.

41. Show that when the crank, in the direct-acting engine (Fig. 181), is at right angles to the connecting rod, the piston is at a distance  $\frac{(1+n) - \sqrt{1+n^2}}{2} \cdot s$  from the back end of the stroke; and that when it is at right angles to the line of stroke, the distance is  $\frac{(1+n) - \sqrt{n^2-1}}{2} \cdot s$ , in which  $s$  is the length of the stroke, and  $n$  the ratio of the length of the connecting rod to the crank radius.

42. Show that the velocity of the piston is equal to that of the crank pin, when the crank angle,  $\theta$ , measured from the inner dead centre is given by—

$$\sin \theta = \frac{n^2}{4} \left( \sqrt{1 + \frac{8}{n^2}} - 1 \right)$$

$$\text{and } \sin \theta = 1;$$

$n$  having the same meaning as in QH.

43. Show that the first value of  $\theta$  in Q. 42 is given graphically by the following construction: Let  $A_0$  be the inner dead centre, and  $A_1, A_2$  the upper and lower extremities of a vertical diameter of the crank-pin circle. Join  $A_0A_2$  and produce it to Q, making  $A_0Q$  equal to half the length of the connecting rod; join  $A_1Q$  and mark off QR along it equal to  $QA_0$ , and with  $A_1$  as centre and radius  $A_1R$  draw an arc of a circle to cut the crank pin circle in S. Then S is the required position of the crank pin.

44. In a torpedo boat destroyer, the stroke is 18", the connecting rod 36" long, and the revolutions of the crank per minute 400. Find the velocity of the piston, and also the revolutions per minute of the three turning pairs, in the

position of the mechanism for which the crank arm has turned through an angle of  $30^\circ$  from its inner dead centre.

*Ans.* Velocity of piston, **1125** feet per minute.

Revolutions of crank shaft, crosshead pair, and crank pin pair, **400, 88, and 488** per minute.

**45.** In Q. 44, the outside diameters of the crank shaft, crank pin, and crosshead pin are  $7\frac{1}{4}$ ",  $7\frac{3}{4}$ ", and  $5\frac{1}{2}$ " respectively. Find the velocity of rubbing of each journal in feet per minute in the position of the mechanism stated, and compare them with the mean piston speed.

*Ans.* Velocity of rubbing of crank shaft, crosshead pin, and crank pin, **760, 128, 992** feet per minute; mean velocity of piston **1200** feet per minute.

**46.** In Q. 44, plot carefully to scale the polar and piston curves of velocity, and mark on your drawing the scale adopted.

**47.** In a locomotive running at 50 miles an hour, the diameter of the driving wheels is 66", the stroke is 27", and the connecting rod is 81" long. Find the actual velocity of the crank pin relative to the rails, in magnitude and direction, when the piston has moved through one-quarter the stroke from the back end.

*Ans.* **100** feet per second, nearly, at an angle of  $10^\circ$  with horizontal.

**48.** An engine has the following dimensions: stroke, 18"; connecting rod, 36"; eccentric radius, 2"; outside lap of valve, 1"; angular advance of eccentric,  $\sin^{-1} \frac{1}{2}$ . Find the point of cut-off, and the velocity ratio of the piston to the valve in that position. The eccentric rod may be assumed of great length.  $\bullet$

*Ans.* Cut off takes place when crank angle is  **$111^\circ$** .

Velocity ratio is **4.2** about.

**49.** A reciprocating motion is given to the table of a small planing machine by a uniformly rotating crank. The connecting rod is horizontal when the crank arm is vertical, and the length of the connecting rod is three cranks. Find the ratio of the times occupied during the return and cutting strokes; and also the length of crank for a stroke of 6".

*Ans.* Time ratio = **1.18** approx.

Crank radius = **2.84"** ,,

**50.** In Q. 49, if the crank radius be halved—everything else remaining unaltered—find the new stroke and time ratio.

*Ans.* Stroke = **2.93"** approx.

Time ratio = **1.12** ,,

**51.** With the mechanism of the direct-acting engine, used as a quick-return motion, the stroke of the tool box is 4", the length of the connecting rod  $7\frac{1}{2}$ ", and the crank radius  $1\frac{3}{4}$ ". Find the position of the crank shaft centre, the time ratio of the two strokes, and the velocity ratio of ram to crank pin in both

## EXAMPLES.

cutting and home strokes when the tool box is one-quarter the stroke from the end of the stroke, measured from the crank shaft end.

$$\text{Ans. Time ratio} = 1.2.$$

$$\text{Velocity ratio} = \begin{cases} 0.84 \text{ approx. in cutting.} \\ 1.18 \text{ in return.} \end{cases}$$

52. If, in Q. 51, the cutting velocity, when the ram is in the middle of its stroke, is 16 feet per minute, find the revolutions per minute at which the crank shaft must rotate.

$$\text{Ans. } 17.6 \text{ revs. per minute.}$$

53. The distance between the crank shaft of an oscillating engine and the centre line of the trunnions is 6 feet, and the stroke is 4 feet. Find the mean and maximum angular-velocity ratios of the cylinder in each of its two swings compared to that of the crank.

$$\text{Ans. Mean, } 0.277 \text{ and } 0.178.$$

$$\text{Max. } 0.5 \text{ and } 0.25.$$

54. In Q. 53, find the velocity of sliding of the piston in the cylinder when the piston is at the middle point of its stroke, (1) referred to the crank-pin velocity; (2) referred to the mean velocity of sliding of the piston.

$$\text{Ans. } 0.98; 1.54.$$

55. In the crank and slotted lever the stroke is 8", and the time ratio of the home and cutting strokes is as 3 : 5. The line of stroke of the ram, produced, passes through the extreme positions of the connecting-rod pin at the end of the slotted lever. If the distance between the centre of the driving plate and the axis about which the slotted lever oscillates is 6", find the lengths of the crank radius and of the lever.

$$\text{Ans. Crank radius} = 2.3'' \text{ approx.}$$

$$\text{Lever} = 10.46'' \text{ ,,}$$

56. In Q. 55, if the crank radius be halved—other things remaining unaltered—find the time ratio and the length of the new stroke, the stroke being assumed perpendicular to the line of centres, and the obliquity of the connecting rod neglected.

$$\text{Ans. Time ratio} = 1.28 \text{ approx.}$$

$$\text{Stroke} = 4.00'' \text{ ,,}$$

57. In a vertical slotting machine, the quick return is obtained by a crank and slotted lever. The distance between the centre of the driving plate and of the oscillating arm is  $6\frac{1}{2}$ "; whilst the distance between the centre of the oscillating lever and the free end of the connecting rod is 13". The driving shaft to which the plate is keyed carries, at its other extremity, a spur wheel of 70 teeth, gearing with one of 12 teeth on the pulley shaft. On the pulley shaft

are three pulleys of 16", 13", and 10" diameter, forming a speed cone; and this is driven from a similar speed cone keyed to the driving shaft, which rotates at 100 revolutions per minute. The length of stroke is 9", and the obliquity of the connecting rod may be neglected. Find the length of the driving arm and the time ratio; also the greatest and least values of the maximum cutting velocity.

*Ans.* Length of driving arm = 2·25" approx.  
 Time ratio = 1·57 "  
 Greatest and least velocities = 48·0 and 18·75 feet per minute approx.

58. In Q. 57, if the stroke be reduced to 3", other things remaining unaltered, find the same things.

*Ans.* Length of driving arm = 0·75" approx.  
 Time ratio = 1·15 "  
 Greatest and least velocities = 19·26 and 7·54 feet per minute approx.

59. In the pin-and-slot mechanism, used for the quick return of a shaping machine, the distance between the two centres of rotation is 3", and the time ratio has to be *two*. If the line of stroke produced pass through the centre of the variably rotating crank, and is perpendicular to the line of centres, find the length of the crank radius, and also of the slotted link, for a stroke of 10".

*Ans.* Crank radius = 6".  
 Slotted link = 5".

60. In the pin-and-slot mechanism, the centre of the variably rotating crank is  $1\frac{1}{2}$ " above the crank shaft, and the line of stroke of the tool box is perpendicular to the line of centres, and when produced passes through the former centre. The stroke is 10", the connecting rod is 18" long, and the time ratio has to be *two*. Find the length of the crank radius, and sketch the mechanism when the tool has made one-quarter of the cutting stroke, the line of stroke being to the right of the line of centres, and the crank shaft rotating in a clockwise direction. And if the velocity of the tool in that position has to be 15 feet per minute, find the revolutions per minute of the driving plate.

*Ans.* Crank radius = 3".  
 Revolutions = 8·45.

61. Sketch to scale the curve of velocity of the tool for both cutting and home strokes in the case of the mechanism of Q. 60.

62. In the pin-and-slot mechanism, the line of stroke is perpendicular to the line of centres, and cuts the line of centres 3" above the centre of the variably rotating crank, and  $4\frac{1}{4}$ " above the centre of the driving plate. The crank radius is 3" long, and the connecting rod 15" long. Find, graphically or otherwise, the length of the slotted lever for a stroke of 10"; and also the time ratio.

*Ans.* Length = 4·9' approx.  
 Time ratio = 1·72 "

63. In the crank-and-lever mechanism shown in Fig. 207, the proportions are—

$$P_1P_2 = 4\cdot00'$$

$$P_1A = 1\cdot52'$$

$$P_2B = 4\cdot43'$$

$$AB = 3\cdot67'$$

Compare the average velocity of B in its two strokes with the average velocity of A; and also the ratio of the times of the two strokes of B.

*Ans.* 0·65 and 0·84.

Time ratio, 1·3.

64. In Q. 64, plot the mechanism in the position for which  $P_1B$  is 4·36' feet; and if the crank shaft  $P_1$  rotate 100 times a minute, find the revolutions per minute which  $P_2$  is making at the instant considered.

*Ans.* 26·4 revs. per minute.

65. In a single Hooke's joint, prove the construction for finding the angular velocity ratio of the two shafts given on p. 204; and also the second expression for the angular-velocity ratio given on the same page.

66. In a Hooke's joint, the axes are inclined at an angle of  $45^\circ$ . Find the maximum and minimum angular-velocity ratios of the two shafts; and also the angular-velocity ratio when the first shaft has moved through  $30^\circ$  from the position shown in Fig. 215.

*Ans.* 1·414 and 0·708.

0·81.

67. In Q. 66, plot the curve of angular-velocity ratio.

68. In Rapson's slide, the wire rope from the steering engines goes first round a fixed pulley at the end of the slide, then round a pulley attached to the carriage, and is then led backward, in a direction parallel to the slide, to a fixed point in the hull. The extreme helm angle is  $35^\circ$ , and the steering engine rotated uniformly. Find the ratio of the angular velocities of the helm when in the extreme and mean positions.

*Ans.* 0·67.

## CHAPTER V.

69. When a train is going at 20 miles an hour, the rain appears to rush down towards a passenger (looking forward) at an angle of  $20^\circ$  with the horizontal. With what speed is the rain descending vertically?

*Ans.* 7·28 miles an hour.

70. A steamer has a velocity of 14 knots due west; the wind blows with a velocity of 7 knots from the north. What will be the apparent velocity of the wind to a person on board the steamer?

*Ans.* 15·6 knots in a direction 63° from W. of N.

71. When a vessel was going due N. at 14 knots, it was observed that the smoke was blown astern on the port side at an angle of 45° with the ship's length. On immediately going due S. at the same speed, the smoke was blown astern on the starboard side at an angle of 30° with the ship's length. Find the speed and direction of the wind on shore.

*Ans.* 12·56 miles an hour in a direction 70° from W. of N

72. In the four-bar chain (Fig. 235), the lengths of  $P_1P_2$ ,  $P_1A$ ,  $AB$ , and  $BP_2$  are 2·5, 1·2, 1·25, and 1·65 feet respectively, and the velocity of the pin A is 10 feet per second. If the angle  $AP_1P_2$  is 60°, find the velocity of B in feet per second, and the angular velocity of  $P_2$  in revolutions per minute; also find the velocity of a point C in  $AB$  distant 0·4' from A respectively.

<i>Ans.</i> Velocity of B	= 6·25 feet per second	}	approx.
Angular velocity of $P_2$	= 36·2 revs. per minute		
Velocity of C	= 8·14 feet per second		

73. Three parallel shafts,  $P_1$ ,  $P_2$ ,  $P_3$ , lie in the same horizontal plane, the distance between  $P_1$  and  $P_2$  being 2', and between  $P_2$  and  $P_3$  1½'.  $P_1$  and  $P_2$  are connected by a four-bar chain,  $P_1ABP_2$ , and the lengths of  $P_1A$ ,  $AB$ , and  $BP_2$  are 1½', 1', and 1½' respectively. A point, C, is attached to A and B by links, AC and BC, of lengths 1¼' and 1', the point C being above AB. To the shaft  $P_3$  is attached a link,  $P_3D$ , which is 2' long, and the extremity D is attached to C by a link, CD, which is 3' long. Plot the mechanism in the position for which the angle  $P_2P_3D$  is 120°, and draw the velocity diagram. If the shaft  $P_1$  have an angular velocity of 10 radians per second, find those of  $P_2$  and  $P_3$ .

*Ans.* Angular velocity of  $P_2$  and  $P_3$  are 11·7 and 2·8 radians per second approximately. (There are two solutions; the above is one of them.)

74. In Peaucellier's cell (Fig. 111), the distance  $P_1P_2$  is 1½', the length of  $P_1C$  is 3½' and the side of the rhombus is 1½'. Plot the mechanism when the angle  $AP_2E$  is 60°, and draw the velocity diagram. Verify, from your diagram, that the point D is moving perpendicularly to  $P_1P_2$ .

75. Referring to Fig. 111, show that if a line, DG, be drawn perpendicular to  $P_1D$  to meet  $P_1P_2$  produced in G, then the velocity ratio of D to A is  $\frac{P_1G}{P_1E}$ ; and compare with the result obtained in Q. 74.

76. In Marshall's valve-gear (Fig. 239), the proportions are as follows:  $P_1A = 1·2'$ ;  $P_1C = 0·25'$ ;  $P_1P_3 = 1·5'$  ( $P_3$  and  $P_1$  being on the same horizontal line); inclination of  $P_3P_2$  to the vertical, 20°;  $P_3P_2 = P_2D = 2'$ ;  $CD = 1·6'$ ;  $CE =$

2'3"; AB = 4'78"; distance between strokes of B and F = 2'4"; EF = 5'7". Plot the mechanism in the position for which the angle  $BP_1A$  is  $135^\circ$ , and draw the velocity diagram. In particular, find the velocity ratio between the valve and piston.

*Ans.* 0.20, valve moving up.

77. In Joy's gear (Fig. 241), the proportions are as follows:  $P_1A = 0.93'$ ;  $AB = 5.2'$ ;  $AC = 3.15'$ ;  $CD = 1.5'$ ; horizontal distance of  $P_2$  from  $P_1 = 6'$ ; vertical distance of  $P_2$  from  $P_1 = 1.13'$ ;  $P_2D = 2.8'$ ;  $CE = 0.5'$ ;  $EF = 1.5'$ . horizontal distance of  $P_3$  from  $P_1 = 5.25'$ ; vertical distance of  $P_3$  from  $P_1 = 0.58'$ ;  $P_3F = 2.25'$ ;  $EG = 1.75'$ ;  $GH = 3.5'$ ; distance between strokes of valve and piston =  $1.13'$ . Plot the mechanism in the position for which the angle  $AP_1B$  is  $45^\circ$ , and draw the velocity diagram. In particular, find the velocity ratio between the valve and piston.

*Ans.* 0.236, valve moving to right.

78. The crank and slotted-lever mechanism (Fig. 243) has the following proportions:  $P_1P_2 = 3.2'$ ;  $P_1C = 1.12'$ ;  $P_2Q = 4.96'$ ;  $QR = 5.42'$ . Plot the mechanism diagram in the position for which the angle  $P_2P_1C$  is  $135^\circ$ ; and find the velocity ratio of the ram, and also the velocity of slotting, in terms of the velocity of the crank pin.

*Ans.* Velocity ratio = 0.95 approx.

Slotting velocity = 0.53 "

79. Check the result obtained in Q. 78 by the method of § 121.

80. In Ollis' steering gear (Fig. 245), the hand- or steam-driven pinion M is 13" diameter, and the radius of the circular rack L is 30". The distance between the rudder-head  $P_1$  and the centre E of the rack, in the mean position of the mechanism, is 10'; and the distance apart of the pins C and D is 20', and of the pins A and B is 33". Find the approximate and true angular-velocity ratio of the rudder-head and pinion, (1) when the rudder is in its mean position, (2) when it is put over  $35^\circ$ . Find also the shift of the centre E of the rack.

*Ans.* In mean position, both time and approximate ratio is 0.131.

In extreme position, approximate solution = 0.0467 about.

" " true " = 0.0585 "

81. In Stephenson's link motion (Fig. 248), the proportions are as follows, the line of stroke of the valve passing through the crank shaft: Inclination of  $P_1A$  to vertical,  $45^\circ$ ; angle  $AP_1B$ ,  $150^\circ$ ;  $P_1A = P_1B = 0.45'$ ;  $AC = BD = 5'$ ;  $CD = 2.1'$ ;  $P_2E = 1.75'$ ;  $CE = 1.08'$ ; vertical distance of  $P_2$  from  $P_1 = 5.06'$ ; horizontal distance of  $P_2$  from  $P_1 = 2.45'$ . Sketch the mechanism in the position given, and draw the velocity diagram. In particular, find the velocity of the valve, and the slotting velocity of the block in the link, expressed in terms of the velocity of A.

*Ans.* Valve velocity, 0.49 up; slotting velocity, 0.19, from left to right.

82. A mechanism consists of a rigid bent lever,  $P_1AB$ , turning about a centre,  $P_1$ , the length of  $P_1A$  being 1', and the angle  $P_2AB$  being  $150^\circ$ . On the portion  $AB$  a block is allowed to slide, and a point,  $C$ , on that block is 1" distant from  $AB$ . A crank arm,  $P_1C$ , 1' long, is coupled to the block at  $C$  and rotates about a centre,  $P_2$ , which is 2.9' from  $P_1$ . Plot the mechanism for the position in which the angle  $P_1P_2A$  is  $60^\circ$ ; and if the velocity of  $C$  be 10 feet per second, find the angular velocity of  $P_2$  and the velocity of slotting.

*Ans.* Angular velocity of  $P_2 = 1.22$  radian per second.  
Slotting velocity = 8.9' per second.

83. In Questions 73, 76, 77, 81, find the required velocity ratios by the method of instantaneous centres, and compare with the previous results.

84. In the direct-acting mechanism (Fig. 183), the line of stroke is 1.95 above the crank shaft, and the lengths of the crank radius and connecting rod are 1' and 8.4' respectively. Find the angle by which the equivalent crank lags behind the actual crank, and also the length of the equivalent crank.

*Ans.* Angle,  $13^\circ$ ; crank radius, 1.025'.

85. In Q. 84, plot the mechanism when the crank arm makes an angle of  $30^\circ$  to the vertical, and compare the velocity ratio of the piston and crank pin, (1) as obtained from the actual crank, (2) as obtained from the equivalent crank.

*Ans.* 0.805 approx.  
0.785 "

86. The slide valve of a horizontal engine is driven from a point,  $C$ , in a link  $AB$ , of such a length that its angular deviation from the vertical is small. The horizontal motions of  $A$  and  $B$  are simple harmonic, defined as follows: For  $A$  half-travel = 2.5", advance =  $20^\circ$ ; for  $B$ , half-travel = 2.5", advance =  $160^\circ$ . If  $AC = \frac{1}{2}AB$ , find half-travel and advance of  $C$ .

*Ans.* Half-travel = 1.46".  
Angular advance =  $36.5^\circ$ .

87. The slide valve of a horizontal steam engine derives its motion from a point  $P$  in a link  $AB$ , where  $AP = \frac{1}{3}AB$ . The horizontal displacements of  $A$  and  $B$  for any crank position  $\theta$  are given by the equations—

$$x_1 = 2.5'' \sin(\theta + 27^\circ)$$

$$x_2 = 2.6'' \sin(\theta + 150^\circ);$$

the resulting motion of the valve being expressed by the equation—

$$x = a \sin(\theta + \alpha)$$

find the half-travel  $\alpha$ , and the angular advance  $\alpha$ .

*Ans.*  $\alpha = 1.39''$   
 $= 58^\circ$ .

88. In the link motion sketched in Fig. 250, the proportions are as follows: Horizontal distance between  $P_1$  and  $P_2 = 2.02'$ ; horizontal distance of line of stroke from  $P_1 = 0.32'$ ;  $P_1A = P_2B = 0.45'$ ;  $AC = BD = 5'$ ;  $CD = 2.1'$ ;  $FD = 1.75'$ ; the angle between the cranks  $P_1A, P_2B = 150^\circ$ . Plot the mechanism when the angle which  $P_1A$  makes with the vertical is  $45^\circ$ ; and find—

- (1) The true velocity ratio between F and A.
- (2) The approximate travel of F.
- (3) The angle between the equivalent crank actuating F and the crank  $P_1A$ .
- (4) The approximate velocity ratio as deduced from the equivalent crank.

*Ans.* (1) 0.454, valve moving up.  
 (2) 0.62".  
 (3)  $7^\circ$  full.  
 (4) 0.44.

89. The proportions of the Stephenson link motion given in Q. 81 practically agree with those of Q. 88, the difference being due to fact that  $P_1$  and  $P_2$  in Fig. 250 coincide with  $P_2$  in Fig. 254. Taking the dimensions of Q. 81, plot the mechanism in the position indicated, and find the equivalent crank, in length and phase difference with PA.

*Ans.* Crank radius = 0.34'  
 Phase difference =  $15^\circ$  ahead of PA.

90. A Stephenson link motion has the following dimensions: Radius of each eccentric, 2.5"; advance,  $18^\circ$ ; length of link, 18"; effective length of slot, 11.5"; length of each eccentric rod, 55". Plot the mechanism when the crank is vertically downwards, and find the half-travel and angular advance of the valve, (1) when working at full gear; (2) when working at mid-gear.

	Full gear.	Mid gear.
<i>Ans.</i> Half-travel,	1.70"	1.22"
Angular advance,	$35^\circ$	$90^\circ$

91. Hackworth's gear (Fig. 256) has the following proportions:  $PA = 1.3'$ ;  $AB = 4.2'$ ;  $PC = 0.5'$ ;  $PQ$  (horizontal) = 3.45';  $\alpha = 45^\circ$ ;  $CD = 3.48'$ ;  $CE = 1.84'$ ;  $EF = 5.06'$ ; distance between strokes of B and F = 1.83'. Plot the mechanism when the angle QPC is  $60^\circ$ , and find—

- (1) True velocity ratio between F and B.
- (2) Travel of F.
- (3) Angular advance of equivalent crank actuating F.

*Ans.* (1) 0.18.  
 (2) 0.7'.  
 (3)  $43^\circ$ .

92. In Q. 91, find the half-travel of valve in mid-gear.

*Ans.* 0.24'.

93. Taking Marshall's gear described in Q. 76, find the travel and angular advance of the equivalent crank actuating E.

$$\begin{aligned} \text{Ans. Travel} &= 0.35' \\ \text{Angular advance} &= 45.5^\circ. \end{aligned}$$

94. In Q. 93, find the same things when in mid-gear.

$$\begin{aligned} \text{Ans. Travel} &= 0.21' \\ \text{Angular advance} &= 90^\circ. \end{aligned}$$

95. In Joy's gear described in Q. 77, find—

- (1) The horizontal and vertical displacement of E.
- (2) The half-travel of valve.
- (3) Angular advance of valve.

$$\begin{aligned} \text{Ans. (1)} &1.22' ; 0.73'. \\ &(2) 0.13'. \\ &(3) 46^\circ. \end{aligned}$$

## CHAPTER VI.

96. In the direct-acting engine mechanism (Fig. 274), the crank arm is 1.55' long, and the connecting rod 3.36' long. Plot the mechanism when the crosshead pin is 4.52' from the crank shaft; and if the uniform velocity of the crank pin is 20' per second, find the velocity and acceleration of the piston by drawing the velocity and acceleration diagrams.

$$\begin{aligned} \text{Ans. Velocity} &= 15.6' \text{ per second} \\ \text{Acceleration} &= 264' \text{ per second per second.} \end{aligned}$$

97. If, in Q. 96, the crank shaft rotate counter clockwise, and the angular acceleration of the crank shaft in a counter clockwise direction is increasing at the rate of ten turns per second per second, find the acceleration of the piston; and also in what interval of time the revolution of the crank shaft will be doubled.

$$\begin{aligned} \text{Ans. Acceleration} &= 340' \text{ per second per second.} \\ \text{Time} &= 0.204 \text{ seconds.} \end{aligned}$$

98. A destroyer engine has a stroke of 18", a rod 36" long, and runs at 400 revolutions per minute. Assuming a uniform speed of rotation, estimate the maximum acceleration of the piston, and compare it with gravity.

$$\begin{aligned} \text{Ans.} &1648' \text{ per second per second} \\ &51.1 g. \end{aligned}$$

99. In Q. 98, draw accurately to scale the curves of acceleration—

- (1) On a piston base.
- (2) On a crank angle base.

## EXAMPLES.

*Scales.* Stroke,  $\frac{1}{2}$  full size.  
 Angle base,  $95^\circ$  to  $1''$ .  
 Acceleration, 500' per second per second to  $1''$ .

100. Show that when the crank is perpendicular to the connecting rod the acceleration of the piston is  $\omega^2 r \frac{\sqrt{1+n^2}}{n^4}$  exactly, and the velocity of the piston is  $\omega r \frac{\sqrt{1+n^2}}{n}$  exactly; and that when the crank is perpendicular to the stroke, the acceleration is  $-\omega^2 r \frac{1}{\sqrt{n^2-1}}$  exactly, and the velocity is  $\omega r$  exactly.

101. Show that when the piston is at the mid-point of stroke the crank angle is  $\cos^{-1} \frac{1}{2n}$ , the velocity of the piston is  $\omega r \frac{n\sqrt{4n^2-1}}{2n^2-1}$ , and the acceleration of the piston is  $\omega^2 r \frac{n(4n^4-6n^2+1)}{(2n^2-1)^3}$ , all exactly.

102. Prove the cubic equation in § 163 for finding the position of the crank shaft for which the acceleration of the piston is exactly zero.

103. Obtain the true expression for the acceleration of the piston given as a footnote to § 167.

104. A four-bar chain (Fig. 291) has the following dimensions:  $P_1A = 3'$ ,  $AB = 2.25'$ ,  $P_2B = 3.9'$ ,  $P_1P_2 = 4.63'$ , and the shaft makes 120 turns a minute at a uniform rate. Find the angular acceleration of the shaft  $P_2$  when the angle  $AP_1P_2$  is  $60^\circ$ .

*Ans.* 198 radians per second per second.  
 34.5 turns per second per second.

105. Taking the mechanisms of Hackworth, Marshall, and Joy given in Q. 91, 76, and 77 respectively, draw the acceleration diagram in each case; and find the acceleration ratio between the valve, piston, and crank pin, the crank shaft in each case being supposed to rotate uniformly.

106. Draw the acceleration for the Peaucellier's cell described in Q. 74, and verify, from your diagram, that the acceleration of the point D is perpendicular to  $P_1P_2$ —the crank shaft rotating uniformly.

107. Referring to Fig. 111, through D draw a line DG perpendicular to  $P_1D$  to meet the lines of centres in G; and through G draw a line perpendicular to the line of centres to meet  $P_1D$  produced in H. Show that the acceleration ratio between D and A, the crank shaft rotating uniformly, is  $\frac{GH}{P_1E}$ , and compare with the result obtained in Q. 106.

108. In the Wigzell engine (Fig 294), the proportions are as follows:  $P_1A = 7.5''$ ;  $AB = 34''$ ;  $AC = 38.7''$ ;  $CB = 17.4''$ ;  $CD = 37.5''$ ;  $CE = 6.7''$ ;  $DF = 5.9''$ ; distance between strokes of E and B =  $17''$ ; distance between strokes of B and F =  $20.4''$ . Plot the mechanism when the angle  $BP_1A$  is  $30^\circ$ , and, if the crank shaft rotate uniformly at 120 revolutions per minute, find (1) the length of three strokes; (2) the linear velocity X, Y, and Z; (3) the accelerations of X, Y, and Z.

*Ans.* The strokes of X, Y, and Z are  $16.6''$ ,  $15''$ , and  $17.6''$

The velocity of A, X, Y, and Z are  $7.84$ ,  $8.1$ ,  $4.65$ , and  $0.64$  feet per second.

The accelerations of A, X, Y, and Z are  $98.4$ ,  $72$ ,  $97$ ,  $127.5$  feet per second.

## CHAPTER VII.

109. If  $n_1, n_2$  be the number of teeth in a pair of wheels which externally mesh together,  $v$  the circumferential velocity of either pitch-circle,  $p$  the pitch, and  $t$  the length of the common normal to the pitch point, show that the velocity of sliding is—

$$2\pi v \left( \frac{1}{n_1} + \frac{1}{n_2} \right) \frac{t}{p}$$

110. The pitch circles of two wheels are  $3''$  and  $6''$  radius, and the flank of the tooth on the smaller wheel is a radial straight line  $\frac{3}{4}''$  long. Construct (§ 173) the form of the tooth on the second wheel to gear with it; and compare the curve so obtained with an epicycloid formed by a circle of  $3''$  diameter, rolling outside the larger pitch circle.

111. If the pressure on the bearings of a pair of wheels with involute teeth be limited to one-tenth of the pressure between the teeth, find the least number of teeth that can be employed in order that the arc of approach is not less than the pitch.

*Ans.* 63.

112. If the arc of approach in cycloidal teeth is three-fourths the pitch, the maximum obliquity  $20^\circ$ , and the radius of the rolling circle one-third that of the pitch circle, find the least number of teeth that can be employed.

*Ans.* 21.

113. The pins of a rack are  $2''$  pitch and  $\frac{1}{2}''$  diameter. It gears with a wheel of 20 teeth. Draw the proper profile for the teeth of the wheel.

2 F

## EXAMPLES.

114. If in Q. 113, the pins be on the wheel, find the profile for the tooth on the rack.

115. A rack having a pitch of 2" meshes with a wheel having 30 teeth. If the face and flank of a tooth on the rack form a continuous straight line, inclined at 70° to the pitch line of the rack, draw the profile of a tooth on the wheel.

116. Two equal spur wheels of 18" diameter mesh together. The pitch of the tooth is 1", its depth below the pitch circle  $\frac{1}{10}$ ", and its height above the pitch circle is  $\frac{3}{10}$ ". If the diameters of the rolling circles are each equal to 6", draw the complete profile of a tooth on either wheel.

117. A pair of spur wheels have 28 and 100 teeth respectively, and the pitch of the teeth is 1". The larger wheel is the driver. The height of the tooth of the follower between the addendum and root circles is  $\frac{3}{8}$ ", and the constant obliquity is 15°. Find the arc of approach, (1) graphically, (2) analytically.

*Ans.* 0·915".

118. If the same proportion hold for the addendum of the tooth on the driver (see Q. 117), find the arc of recess.

*Ans.* 1·06".

119. A pair of spur wheels have 28 and 100 teeth respectively, and the pitch is 1". The flanks of the teeth of each wheel are radial straight lines, and the arcs of approach and recess are each equal to the pitch. The larger wheel drives. Find the heights of the teeth in the two wheels between the addendum and pitch circles.

*Ans.* In driver, 0·256".

In follower, 0·175".

120. By a graphical construction, determine the arcs of approach and recess, and the maximum obliquity, of a pair of cycloidal teeth according to the following data, and state how many pairs of teeth are in action at the same time, the smaller wheel being the driver.

Pitch = 2"  
 Number of teeth = 30 and 50  
 Diameter of rolling circles =  $8\frac{3}{4}$ "  
 Addendum of teeth =  $\frac{1}{8}$ "

*Ans.* Arc of approach = 2·07".

Arc of recess = 2·03".

Number of pairs of teeth = 2.

CHAPTER VIII.

121. The distance between the centres of rotation of two non-circular pitch surfaces is 3'. The forms of the surfaces have to be such that the angular velocity ratio transmitted is equal to 0.5, 0.6, 0.7, 0.8, 0.9, 1.0, 0.9, 0.8, 0.7, 0.6, 0.5 for equal angles of 15° turned through by the first wheel. If there is no sliding between the surfaces, find the forms of the two pitch lines.

122. In Harfield's gear (Fig. 373), the diameter of the driving wheel A is 2', and the centre of rotation is 6" from the centre of the wheel. The distance between the centres of rotation P<sub>1</sub> and P<sub>2</sub> is 6'. Draw the form of the rack for a half-turn of the driving wheel, and state the extreme helm angle. Find also the angular-velocity ratio between the rudder-head and driving wheel in the mean and extreme positions of the gear.

*Ans.* Angular-velocity ratios,  $\frac{1}{8}$  and  $\frac{1}{11}$ .

123. Motion is transmitted between two parallel shafts by two elliptic wheels. The distance between the centres is 4", and extreme velocity ratios have to be 3 and  $\frac{1}{3}$ . Find the major and minor axes of the ellipses.

*Ans.* Major axis = 4".

Minor axis = 3.46".

124. If the elliptic wheels in Q. 123 be used as a quick-return motion, as shown in Fig. 378, find the time ratio of the home to the cutting stroke.

*Ans.* 4 approx.

125. Two circular wheels, one 4" and the other 6" diameter, rotate eccentrically about pins which are 4.5" apart. The eccentric radii of the two wheels are 1" and 2" respectively. Plot the mechanism in the position for which the larger eccentric radius is perpendicular to the line joining the centres of the wheels, and find the angular-velocity ratio between the large and small wheels in this position.

*Ans.* 2 about.

126. Design a cam to lift vertically a moving piece at a uniform speed through 3", the return motion being also uniform and at half the speed. The diameter of the roller is  $\frac{1}{2}$ ", the least width of metal round cam centre is  $2\frac{1}{2}$ ", and the line of stroke produced passes through cam centre.

127. Draw a cam which has to raise a valve at a uniform rate through 6" in two-fifths of a revolution, and lower it through the same distance in one-fifth of a revolution. The valve remains at rest in the upper position for one-tenth of

a revolution, and in the lower position for the rest of a revolution. The diameter of the shaft is 4", the least width of metal round shaft is 2", the diameter of the roller is  $\frac{1}{2}$ ", and the line of stroke produced passes through cam centre.

128. If, in Q. 127, the line of stroke is 2.5" to one side of the cam shaft centre, design a cam to give the same motion.

129. A plane face, attached to a reciprocating piece, is acted on by a rotating cam. In its lowest position the plane face is 2" from the cam shaft centre, and the line of stroke of the slide is 1" to one side of the cam centre. If the slider rises uniformly through 2" whilst the cam shaft rotate uniformly through  $180^\circ$ , find the proper shape for the acting edge of the cam.

# INDEX.

*The numerals refer to pages.*

## A.

- ACCELERATION diagram, 244, 246
- ,,       ,,       for direct-acting mechanisms, 249, 258, 260
- ,,       ,,       for four-bar chain, 264
- ,,       ,,       for Wigzell's engine, 265
- Addendum circle, 270
- Adjustable multiple-spindle drilling machine, 208
- Aggregate motions, 34
- Air drills : Little Giant, 192 ; Bradford, 195
- Amsler's planimeter : description, 383 ; proof of principle, 384
- Angular-hole drilling machine, 149
- Annular wheels, 93
- Approximate solution for acceleration of piston, 260
- Arcs of approach and recess, 298
- Automatic power chuck, mechanism of, 85
- ,,       screw-cutting machine, 102

## B.

- BACK gear, quick change, 56
- Back gearing, of lathes and drilling machines, 55
- Beam engine, 128
- Belts, crossed and open, 22
- ,,       for speed cones, 23
- ,,       lateral stiffness of, 26
- ,,       to connect two non-intersecting shafts, 30
- Bevel gear planers : Bilgram, 317 ; Gibson, 322
- ,,       wheels, 37
- ,,       ,,       teeth of, 306
- Bilgram bevel gear planer, 317
- Blowers, rotary, 331 ; shapes of, 333
- Boring and turning mills, 71

Boring machine, horizontal, 80  
 Bradford air drill, 195  
 Breech mechanism of guns, 179  
 Brick press, mechanism of, 186

## C.

CALDWELL'S steering engine, 95  
 Cams, general problem, 356  
 ,, special problems, 358, 360, 362, 363, 366, 367, 36  
 ,, heart, 360  
 ,, triangular, 364  
 ,, applied to shaping or punching machines, 369  
 ,, ,, gas engines, 370  
 ,, ,, Kermod's steering gear, 371  
 ,, ,, indicator rigs, 372  
 Capstan engine, mechanism of, 47  
 Chain wheels, ordinary, 295 ; Renold's, 297  
 Change-speed gears, for lathes and motor cars, 59  
 Change wheels, ordinary, 59, 66  
 ,, ,, quick, 60-65  
 Chuck, ordinary, 86  
 ,, mechanism of automatic power, 87  
 ,, elliptic, 141  
 Clamps, geometrical, 377  
 Clicks, 104  
 Cog, hunting, 44  
 Complex machines, 17  
 Compound wheels, 43  
 Cones, speed, for crossed and open belts, 23  
 Constraint of a point and rigid body, 375  
 Copying lathe, 148, 368  
 Counters, engine, 108  
 Couplings, Oldham's, 141, 208  
 ,, pin and slot, 189  
 ,, four-bar chain, 197  
 ,, Hooke's joint, 201  
 ,, universal, 205  
 Crank and slotted-lever mechanism, 183, 223  
 Crosby indicator, 133  
 Cross feed, mechanism of planing and shaping machines, 109  
 Crown wheels, 39, 309  
 Curved plates, rotating about parallel axes, 273, 336, 346  
 Curves of acceleration of piston, 251  
 ,, ,, ,, neglecting obliquity, 257  
 Curves of velocity, for direct-acting engine, 168  
 ,, ,, for quick return, 171

- Curves of velocity, for crank and slotted lever, 183  
 ,, ,, for pin and slot, 189  
 ,, ,, for four-bar chain, 197  
 ,, ,, for Hooke's joint, 203  
 ,, ,, and acceleration, relation between, 259  
 Cycloidal teeth, 284  
 ,, ,, minimum number, 289  
 Cyclometer, illustration of, 94  
 Cylinder-integrating machine, 380

## D.

- DAVIS' steering gear for motor cars, 138  
 Dead points, 170  
 Differential windlass, 33  
 Direct-acting engine, application of instantaneous centre, 157  
 ,, ,, ,, ,, ,, ,, curve of velocity, 168  
 ,, ,, ,, ,, ,, ,, velocity of diagram, 219  
 ,, ,, ,, ,, ,, ,, acceleration of piston, Klein's construction, 249  
 ,, ,, ,, ,, ,, ,, approximate solution, 260  
 Disc-integrating machine, 380  
 Donkey pump, 209  
 Double crank chain, 197  
 ,, helical gearing, 306  
 ,, Hooke's joint, 205  
 ,, lever chain, 197  
 ,, slider crank chain, 208  
 Drag link mechanism, 197  
 Drilling machines, back gearing of, 55, 56  
 ,, ,, general description, 74  
 ,, ,, rack traversing, 77  
 ,, ,, hand, 77  
 ,, ,, radial, 79  
 ,, ,, multiple spindle, 79  
 ,, ,, horizontal boring and, 80  
 ,, ,, for drilling oval holes in flat plates, 144  
 ,, ,, square, angular, and round hole, 149  
 ,, ,, adjustable multiple spindle, 208  
 ,, ,, Little Giant air, 192  
 ,, ,, Bradford, 195

## E.

- ECCENTRIC, 162  
 Elements, kinematic pair of, 4  
 „ number in chain, 10  
 Elliptic chuck, 141  
 „ holes in flat plates, 144  
 „ trammels, 115  
 „ wheels, 341  
 Engine counters, 108  
 Epicyclic trains, 88

## F.

- FAST and loose pulleys, 28  
 Feathering paddle wheels, 165  
 Fellows spur-gear shaper, 311  
 Four-bar chain, application of instantaneous centre, 55  
 „ „ curves of velocity, 197  
 „ „ velocity diagram, 218  
 „ „ acceleration diagram, 264  
 „ „ equivalent to elliptic wheels, 341  
 Four-piece mechanism, description, 406  
 „ „ graphic solution of co-ordinated moments, 409  
 „ „ varieties of material form, 411  
 Friction disc, 39  
 „ rollers, 36

## G.

- GAS-ENGINE valves, cams actuating, 370  
 Geometrical slides and clamps, 377  
 Giant air drill, 192  
 Gibson's bevel-gear shaper, 322  
 „ worm-wheel shaper, 326  
 Globe-integration machine, 380  
 Grasshopper parallel motion, 115  
 Grisson gear, 293  
 Guide pulleys, 29  
 Guns, breech mechanism of, 179  
 Gearing, worm. *See* Worm-gearing

## H.

- HACKWORTH'S valve gear, true and approximate solution, 235  
 Hand drill, 77  
 „ press, 21, 199  
 Harfield's steering gear, 339  
 Hart's parallel motion, 113  
 Heart cam, 360  
 Height of teeth, 298

- Hele Shaw, on profiles of teeth, 27  
 Helical gearing, 303  
 Higher pairs, definition of, 4  
 Holt's rotary steam engine, 196  
 Hopke's joint, curves of velocity, 201  
   "   "   application to testing machine, 206  
   "   "   double, 205  
   "   "   degree of the most general character, 378  
   "   "   mechanical illustration, 379  
   "   "   application to drilling machine, 208  
 Horizontal boring and drilling machine, 80  
 Humpage's gear for lathes, 100  
 Hunting cog, 44  
 Hydraulic engine, Rigg's, 194

## I.

- IDLE wheel, 44  
 Inclined plane, 18  
 Indicator rigs, 135-138, 372  
 Indicators, link mechanism of, 129  
   "   Crosby, 133  
   "   Richards, 131  
   "   Simplex, 130  
   "   Tabor, 132  
   "   Thompson, 132  
 Instantaneous centre of rotation, 153  
 Instrument, definition of, 5  
 Integrating machines, disc-, globe-, and cylinder-, 380  
   "   "   Amsler's, 383  
 Intermittent motions, by ratchets, 104  
   "   "   by toggles, 179  
 Involute teeth, formation of, 281  
   "   "   advantages of, 283  
   "   "   minimum number of teeth of, 289

## J.

- JACK-IN-THE-BOX mechanism, 97  
 Joy's valve gear, number of pairs of elements, 13  
   "   "   velocity diagram, 221  
   "   "   approximate solution of, 241

## K.

- KERMODE'S steering gear for ship, 371  
 Kinematic chain, 5  
   "   pair of elements, 4  
 Klein's construction for acceleration of piston, 249

## L.

- La Garousse, levers of, 106  
 Lateral stiffness of belts, 26  
 Lathes, ordinary back gearing, 55  
   ,, quick-change back gearing, 56  
   ,, change speed gears, 59  
   ,, quick-change gears, 60-65  
   ,, screw cutting and traversing, 66  
   ,, copying, 148  
 Lever, 18  
   ,, crank chain, curves of velocity, 197  
 Levers of La Garousse, 106  
 Line contact, 3  
 Link motion, Stephenson's, velocity diagram, 227 ; approximate solution, 230  
 Little Giant air drill, 192  
 Lobed wheels, 344  
 Logarithmic wheels, 344  
 Loose and fast pulleys, 28  
 Lower pairs, 4

## M.

- MACHINE, definitions connected with, 1-16  
   ,, cut teeth, 311  
 Marshall's valve gear, velocity diagram, 220  
   ,, approximate solution, 239  
 Milling machine, description, 392  
 Mitre wheels, 37  
 Motor cars, change-speed gears, 59-65  
   ,, jack-in-the-box mechanism, 97  
   ,, Davis' steering gear, 138  
 Multiple-spindle drilling machines, 79, 208  
 Multiple-threaded screws, 19

## N.

- Non-circular wheels, determination of angular-velocity ratio and sliding velocity, 336  
   ,, determination of pitch curves, 338  
   ,, general case, 346  
   ,, profiles of teeth of, 353

## O.

- OBLIQUE-ACTING tackle, 35  
 Oldham's coupling, 141, 208  
 Ollis' steering gear for ships, 225

Oscillating cylinder engine, 182  
 Oval-hole drilling machine, 144

## P.

PADDLE wheels, feathering, 165  
 Pair of elements, higher and lower, 4  
 Pairs, number in chain, 10  
 „ minimum number of, 16  
 Pantograph, various forms of, 125  
 „ application to rail sections, 126  
 „ „ beam engines, 128  
 „ „ indicators, 129  
 „ „ indicator rigs, 135  
 Parallel motions, Grasshopper, 115  
 „ Hart, 113  
 „ Peaucellier, 112  
 „ Roberts, 119  
 „ Scott-Russell, 114  
 „ Sarrut's, 386  
 „ Tchebicheff, 118  
 „ Watt, 120  
 Peaucellier's cell, 13, 112  
 Pin wheels, profiles of teeth, 291  
 „ wheel and rack, profiles of teeth, 294  
 „ rack and wheel, profiles of teeth, 294  
 Pin and slot, application of instantancous centre, 157  
 „ as coupler, 189  
 „ as quick return, 191  
 Pinion and rack, profiles of teeth, 290  
 Pitch lines, 39, 270, 336, 355  
 „ of screw, 19  
 „ of teeth, 39  
 Planimeter, Amsler's, description, 383  
 „ proof of principle, 384  
 Planing machines, mechanism for driving table, 47  
 „ return motions, 49, 51  
 „ quick-return motions, 52-55  
 „ cross-feed for tool, 109  
 Pneumatic riveter, mechanism of, 181  
 Point, constraint of, 375  
 Point paths, 6  
 Poncelet, construction for finding teeth profiles, 275  
 Power chuck, mechanism of automatic, 85  
 Printing machine, automatic delivery of sheets, 163  
 Profiles of teeth, kinematic conditions, 273  
 „ suitable shapes, 280

- Profiles of teeth, of bevel wheels, 307  
 „ of non-circular wheels, 355  
 Propeller blades, machine for facing, 147  
 Pulley block, Weston's, 33  
 „ blocks, 31  
 Pulleys, belt driving, 21  
 „ swell of, 26  
 „ fast and loose, 28  
 „ guide, 29  
 Pump, donkey, 209  
 „ Worthington's direct-acting, 210  
 „ rotary, 331  
 Punching machines, application of cams, 369

## Q.

- QUICK-CHANGE back gear for lathes, 56  
 „ feed motions, by sliding wheels, 60  
 „ „ „ sliding key, 61  
 „ „ „ sliding jaw clutches, 52  
 „ „ „ tumbler, 64  
 Quick-return motions, of planing machines, 52-55  
 „ „ by direct action, 171, 174  
 „ „ by crank and slotted lever, 183  
 „ „ by pin and slot (Whitworth), 191  
 „ „ by non-circular wheels, 340  
 „ „ by elliptic wheels, 341

## R.

- RACK, 33  
 Rack-and-pin wheel, tooth profiles, 294  
 Rack and pinion, tooth profiles, 290  
 Rack traversing drill, 77  
 Radial drilling machine, 79  
 „ valve gears, approximate solutions, 235  
 Rapson's slide, 211  
 Ratchet brace, 108  
 „ wheels, 104  
 Relation between curves of velocity and acceleration, 259  
 Relative motion, definition of, 6  
 Renold's chain gearing, 297  
 Return motions of planing machines, 47-55 : *see* Quick-return motions  
 Reverted trains, 91  
 Richards' indicator, 131  
 Rigg's hydraulic engine, 194  
 Rigs, indicator, 135, 372  
 Rigid body, constraint, 375

- Riveter, mechanism of pneumatic. 181  
 Robert's parallel motion, 119  
 Rolling cylinders, 162, 166  
 ,, circle, minimum diameter in cycloidal teeth, 284  
 Root circle, 270  
 Rotary pumps and blowers, 331  
 ,, steam engine, Hult's, 196  
 Rudder-heads of ships, mechanisms for actuating, 83, 211, 225, 339, 371

## S.

- SARRUT'S parallel motion, 386  
 Scott-Russell parallel motion, 114  
 Screw-cutting lathe, 66  
 ,, machine, automatic, 102  
 Screws, single and multiple threaded, etc., 19  
 Section of rails, machine for obtaining, 126  
 Sellars' spiral gear, 391  
 Shafts, to detect difference of speed of, 97  
 Shaping machine, cross-feed to tool box, 109  
 ,, quick-return motions, 171, 191, 340  
 Shipper mechanism, for planing machines, 49  
 Simple lever, 18  
 Simplex indicator, 130  
 Single-threaded screw, 19  
 Skew-bevel wheels, 41 ; teeth of, 310  
 Slide, geometrical, 377  
 Slider crank chain, 168  
 Slotting machine, 144, 191  
 Smith, Prof. R. H., on velocity and acceleration diagrams, 213, 244  
 Speed cones, 23  
 Spiral gear, Sellars', 391  
 Spur wheels, 36, 270  
 ,, gear shaper, Fellows, 311  
 Square-hole drilling machine, 149  
 Stanhope levers, 199  
 Steam engine indicator rigs : *see* Rigs  
 ,, indicators : *see* Indicators  
 Steering engines, 83  
 ,, Caldwell's, 95  
 ,, Davis', 138  
 ,, Rapson's, 211  
 ,, Ollis', 225  
 ,, Harfield's, 339  
 ,, Kermodé's, 371  
 Stephenson's link motion, velocity diagram, 227



Toothed wheels, 36, 39, 270  
 Trains of wheels, 43  
 Traversing lathes, 70  
 Triangular cam, 364  
 Turning and boring mills, 71  
 Turret, illustration of, 46

## U.

UNIVERSAL coupling, 205  
 Universal milling machine, 392

## V.

VALUE of train of wheels, 43  
 Valve, gas engine, 370  
 Valve gears, Hackworth's, 235  
 „ Marshall's, velocity diagram, 220  
 „ „ approximate solution, 239  
 „ Joy's, number of pairs, 13  
 „ „ velocity diagram, 221  
 „ „ approximate solution, 241  
 Vectors, definition of, 213 ; illustrations, 215 ; as applied to mechanisms, 216  
 Velocity diagrams, 213  
 „ of four-bar chain, 218  
 „ of direct actor, 219  
 „ Marshall's valve gear, 220  
 „ Joy's valve gear, 221  
 „ crank and slotted lever, 223  
 „ Ollis' steering gear, 225  
 „ Stephenson's link motion, 227  
 „ Hackworth's valve gear, 235  
 „ Wigzell, 265  
 Velocity ratio, determination of, by instantaneous centre, 152

## W.

WATT's parallel motion, 120  
 „ „ effect of obliquity, 122  
 „ „ design of, 124  
 Wedge, 21  
 Weston's pulley block, 33  
 Wheel and axle, 18  
 Wheels, annular, 93  
 „ bevels, 37, 306  
 „ chain, 295

Wheels, change, for lathes, 59-66

- „ compound, 43
- „ crown, 39
- „ idle, 44
- „ mitre, 37
- „ non-circular, 336
- „ ratchet, 104
- „ skew bevels, 41, 310
- „ spur, 36
- „ toothed, 36, 39, 270
- „ train of, 43
- „ worm, 41

Wheel-and-pin rack, 294

Whitworth quick return, 191

Wigzell's engine-acceleration diagram, 265

Willis on profiles of teeth, 276

Windlass, differential, 33

Worm wheel shaper, Gibson, 326

Worm wheels, 41

- „ teeth of, 310

Worm gearing, 394

- „ form of teeth of worm and worm wheel,
- „ generation of contact of surface of worm, 398
- „ influence of relative curvature on profiles of contact, 402

Worthington's direct-acting pump, 210

THE END.





















