

**THE BOOK WAS
DRENCHED**

UNIVERSAL
LIBRARY

OU_168870

UNIVERSAL
LIBRARY

ELECTRICITY AND MAGNETISM

ELECTRICITY AND MAGNETISM

FOR ADVANCED STUDENTS

BY
SYDNEY G. STARLING, B.Sc., A R.C.Sc.

HEAD OF THE PHYSICAL DEPARTMENT, MUNICIPAL TECHNICAL
INSTITUTE, WEST HAM

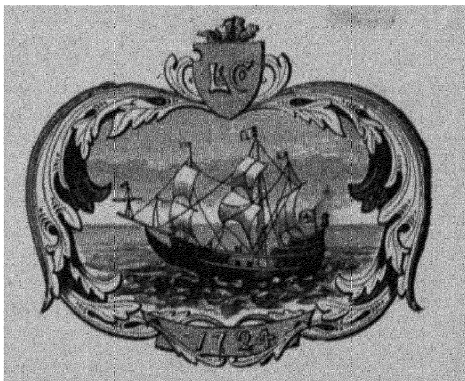

WITH DIAGRAMS

FIFTH IMPRESSION

LONGMANS, GREEN AND CO.
39 PATERNOSTER ROW, LONDON
FOURTH AVENUE & 30TH STREET, NEW YORK
BOMBAY, CALCUTTA, AND MADRAS

1911

All rights reserved

Made in Great Britain

PREFACE

THE present volume is the outcome of the teaching of electricity and magnetism to senior students during a number of years, and the attempt has been made to give such students an adequate knowledge of the present state of the subject, with due reference to the historical sequence of its development, and to the effect of modern research upon it. In dealing with the latter phase, the choice of what to use and what to leave presents great difficulty, but the idea has been kept in view, to incorporate that which forms a part of the general scheme, and at the same time has come to be looked upon as firmly established and not likely to be greatly modified in the near future.

The order of treatment is one that appears from experience to be the best, and at the same time copies to some extent the derivation of the units on the electromagnetic system. Thus, the transition from magnetism to current electricity, and from this to electrostatics, presents a gradual development of ideas built in the first place upon magnetic phenomena. The theory of electrolysis takes its place after electrostatics, since in dealing with it, a knowledge of a quantity of charge is essential. The order of the remainder—electromagnetics, alternating currents, waves, current in gases, radioactivity, etc.—with a final chapter dealing with some of the results of the electronic theory does not call for special remark.

The dividing line between what is technical and what is not, is becoming increasingly difficult to draw. Without in any case giving details or design of machinery, it has been attempted to elaborate the principles involved, so that a student should subsequently have no difficulty in following work of a more technical character. No apology is offered for using the methods of the differential and integral calculus whenever it appeared that an advantage was gained by so doing, since it is imperative that a student who wishes to pursue his studies in electricity must have so much mathematical equipment. Endeavour has been made throughout to present clearly that a differential coefficient is a rate, and an integral a summation. The few simple differential equations that it is necessary to solve have been treated very fully and should present no difficulty.

The very greatest indebtedness must be expressed to the standard

works, such as those of Professors Gray, Ewing, Rutherford, and Sir J. J. Thomson, to which every student of electricity owes so much, and also to those lectures given in the Royal College of Science, London, by Sir Arthur Rücker, late Professor of Physics there, to whom the author owes his first advanced knowledge of the subject. But thanks are also due to Mr. G. Dean, M.A., and Mr. P. R. Friedlaender, of the West Ham Municipal Technical Institute, the former for valuable suggestions in the chapter on Electrolysis and the latter for the curves from which Fig. 333 is made; also to those firms and publishers who have so kindly lent diagrams.

SYDNEY G. STARLING.

WEST HAM,
July, 1919

PREFACE TO SECOND EDITION

ERRORS have been corrected and additions made, more particularly in the subjects of Positive Rays, X-rays, and Thermionics. These being each the subjects of extensive work, it has only been possible to give them in briefest outline, but the references should enable the student to find the larger works without difficulty.

The greatest indebtedness must be acknowledged to those who have kindly pointed out errors in the first edition and have sent suggestions for alterations.

S. G. S.

WEST HAM.
1916.

CONTENTS

CHAP.	PAGE
I. MAGNETISM (INTRODUCTORY)	1
II. TERRESTRIAL MAGNETISM	19
III. THE ELECTRIC CURRENT	51
IV. THE ELECTRIC CURRENT (<i>continued</i>)	75
V. ELECTROSTATICS	109
VI. ELECTROSTATICS (<i>continued</i>)	149
VII. ELECTROLYSIS	172
VIII. THERMO-ELECTRICITY	203
IX. ELECTROMAGNETICS	225
X. MAGNETIC PROPERTIES OF MATERIALS	266
XI. VARYING CURRENTS	301
XII. ALTERNATING CURRENTS	313
XIII. UNITS	382
XIV. ELECTROMAGNETIC RADIATION	406
XV. CONDUCTION IN GASES	464
XVI. RADIOACTIVITY	497
XVII. ELECTRONS	524
APPENDIX (Positive Rays, X-rays, and Thermionics)	561
EXAMPLES	567
INDEX	581

CHAPTER I

MAGNETISM (INTRODUCTORY)

Magnets and Magnetic Poles.—The original observations which led to the development of the study of Magnetism are—the setting in one particular direction of a piece of lodestone or magnetite when freely suspended, and the picking up of small pieces of magnetite or iron by a larger piece of magnetite. Further, a similar polarity is produced in pieces of steel by the simple process of rubbing from one end to the other with that part of the magnetite where iron filings cling in greatest quantity. The piece of steel will then set with one particular end pointing approximately north when suspended so that it is free to turn in a horizontal plane, and it will easily pick up iron filings.

A knitting needle may be used for the purpose of the above experiment, and by magnetising several such needles and suspending each of them in turn in a stirrup supported by a single silk fibre, the ends which point to the north may be determined. These ends are called the north-seeking poles, or, more shortly, the N poles of the needles; the other ends are of course the south-seeking or S poles. If then one of the needles be suspended and the poles of one of the others brought in turn near its poles, it is at once seen that two N poles repel each other, as do two S poles, but that a N pole and a S pole attract each other.

When two magnetic poles are brought near to each other, the force between them is the most important guide we have with regard to the strength of the poles; in fact, we can only define an equality between two poles, when they experience equal forces on being brought in turn into identical positions with respect to a third pole. If we follow out this conception and imagine a number of equal poles to be produced, we shall then see that by combining these arbitrary unit poles, which we will imagine to be all of one kind, to form two poles A and B, the force between A and B is proportional to the product of the number of units in each; for if either be increased n times by the addition of more units, the force is also increased n times, provided that the force between any two units is in no way affected by the presence of other poles. Experience tells us that magnetic forces are in this respect like gravitational forces; the presence of a third body does not affect the force between

any other two. Hence we may say that the force between two magnetic poles varies as the product of their strengths.

The Inverse Square Law.—The law of variation with their distance apart, of the force between two poles, must be determined experimentally. But here again a consideration of the case of gravity helps us. If we imagine two magnetic poles each concentrated at a point, the force between them will vary inversely as the square of their distance apart. The experimental proof was first undertaken by Coulomb, who, using his torsion balance, showed the law to be true within about three parts per hundred.

A similar degree of accuracy may be obtained with the Hibbert magnetic balance, but all these direct and simple proofs are made on the assumption that the poles of magnets are situated at or near definite points close to the ends of the magnets, whereas this is never the case. In the experiment of picking up the iron filings or of approaching one magnet to another to observe the force between poles, it is evident that the magnetic effects extend over large parts of the surfaces of the magnets, being very small or zero near the middle and increasing towards the ends. The conception of point poles, however, is a very important one, and we have every reason to believe that for such poles the law of force is the inverse square law ; that is

$$\text{Force} = k \frac{m_1 m_2}{r^2}$$

where m_1 and m_2 denote the strengths of the poles measured in any arbitrary units and r is their distance apart. If the N pole be given a positive sign and the S pole a negative one, it follows if k is positive that a positive force is a repulsion, whereas an attraction is negative. The direct experimental proof of this law is impossible, but we shall see on p. 9 that the experiments of Gauss establish it with a fair degree of accuracy. The most important reason for accepting the truth of the law lies in the fact that, *without exception*, effects calculated on the assumption of its truth are in accordance with experimental results, always within the limits of accuracy of which the experimental work is capable.

Units.—In choosing our units, those of *force* and *distance* are already fixed for us on the scientific system, otherwise known as the Centimetre-Gramme-Second system. It is therefore most convenient to choose our *unit of magnetic pole* so that the constant k in our equation becomes unity, and this will be the case if the unit values of m_1 and m_2 are such that the force between the poles is one dyne when their distance apart is one centimetre. The medium in which the poles are situated will not be considered at the present time ; they will be assumed to be situated in vacuo, or what is nearly the same thing for magnetic purposes—in air. Thus the unit pole may be defined as the pole which placed in air one centimetre from an equal pole repels or attracts it with a force of one dyne ; and for the force

between any two poles whose strengths are measured in terms of these units,

$$\text{Force} = \frac{m_1 m_2}{r^2} \text{ dynes (1)}$$

Magnetic Field.—Relation (1) by itself is of very little use ; we can only find by means of it the force on a pole when the magnitude and position of all other poles are known. These are never known in any real case ; in fact, the force may not, strictly speaking, be due to “poles” at all ; and yet it is very important to be able to express the force on the given pole in terms of external effects. The resultant of all forces acting on the pole for any given arrangement of magnetic bodies depends upon its position ; and if the pole be a N pole of unit strength, the force upon it is called the *Strength of Magnetic Field* at the point, or the *Magnetic Force*, or *Intensity*, the symbol usually used to denote it being *H*.

It follows that the force on any pole of strength *m* is equal to *Hm*, or

$$F = Hm (2)$$

It must be noticed that *H* is a vector quantity like a force, and is subject to the law of addition of vectors, sometimes known as the law of the parallelogram of forces.

We can now calculate the magnetic field in several simple cases, the general process being to imagine a unit N pole to be placed at the point at which we require the field, calculate the force upon it due to each known pole, and then find the resultant.

Thus the field at a distance *r* cms. from a N pole of strength *m* is $+\frac{m}{r^2}$; for putting $m_1 = +m$, and $m_2 = +1$ in equation (1) we have

$F = \frac{m}{r^2}$, the strength of field required.

Field due to Magnet.—Case (i).

Let the point P (Fig. 1), at which the field is required, be situated on the line joining the poles of the magnet and at a distance *d* from its middle point.

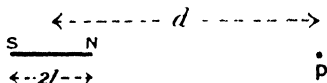

FIG. 1.

If *m* be the strength of pole of the magnet and *l* half its length,

$$\begin{aligned} \text{Field at P due to N} &= \frac{m}{(d - l)^2} \\ \text{'' '' '' S} &= - \frac{m}{(d + l)^2} \end{aligned}$$

Since these two are in the same line,

$$\text{Resultant field} = \frac{m}{(d - l)^2} - \frac{m}{(d + l)^2} = \frac{4ml d}{(d^2 - l^2)^2}$$

If the length of the magnet is so small that l^2 is negligible in comparison with d^2 ,

$$\text{Resultant field} = \frac{4ml}{d^3}.$$

Case (ii).

P being situated on a line bisecting the magnet at right angles

(Fig. 2), the field PA due to N has strength $\frac{m}{d^2 + l^2}$, since $PN = \sqrt{d^2 + l^2}$.

Similarly field due to S, $PB = \frac{m}{d^2 + l^2}$.

The resultant field is evidently PR, and from the geometry of the figure we see that

$$\frac{PR}{PA} = \frac{NS}{PN}$$

$$\text{or, } PR = PA \cdot \frac{NS}{PN}$$

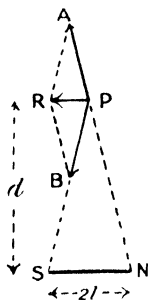

FIG. 2.

$$\text{thus, resultant field} = \frac{m}{d^2 + l^2} \cdot \frac{2l}{\sqrt{d^2 + l^2}}$$

$$= \frac{2ml}{(d^2 + l^2)^{3/2}}$$

As in Case (i), if l is small in comparison with d ,

$$\text{resultant field} = \frac{2ml}{d^3}.$$

Magnetic Moment.—We are now in a position to deal with the case of a suspended magnet, free to turn in a horizontal plane. Such a magnet comes to rest with its N pole pointing north. The magnet is evidently situated in a magnetic field, known in this case as the Earth's Field; and assuming this to be equivalent to a horizontal magnetic field of strength H , the N pole of the suspended magnet experiences a force $+Hm$ and the S pole a force $-Hm$, the two giving rise to a couple whose turning moment is equal to either force multiplied by the perpendicular distance AN between them (Fig. 3).

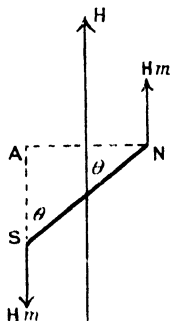

FIG. 3.

$$\therefore \text{Couple} = Hm(AN)$$

$$= Hm \cdot NS \cdot \sin \theta.$$

This couple vanishes when the magnet has a position parallel to H , the magnetic meridian, that is when $\theta = 0$; which explains the setting of the compass needle in a N and S direction.

The expression for the couple acting on the needle consists of three

parts, H depending on the Earth, θ on the position of the magnet, and $m \cdot NS$ depending on the magnet itself. The last quantity is called the magnetic moment M of the magnet. In the case of a fictitious magnet consisting of two point poles, it is the *strength of pole multiplied by the distance between the poles*, but the definition of magnetic moment from the expression

$$\text{Couple} = HM \sin \theta (3)$$

does not depend upon any such fiction, for any magnet may be suspended in a magnetic field and the couple required to maintain it in a given position measured, and M therefore found.

If the magnet be maintained at right angles to the magnetic field, $\theta = 90^\circ$ and $\sin \theta = 1$.

$$\therefore \text{Couple} = HM,$$

and we may from this, define the moment of a magnet as *the couple required to maintain it at right angles to a magnetic field of unit strength*.

We see that the expressions for the field due to a magnet become

$$\begin{array}{l} \text{Case (i)} \quad \frac{2Md}{(d^2 - l^2)^2} \quad \text{or} \quad \frac{2M}{d^3} \\ \text{Case (ii)} \quad \frac{M}{(d^2 + l^2)^{\frac{3}{2}}} \quad \text{or} \quad \frac{M}{d^3} \end{array}$$

where M is substituted for $2ml$, the length of the magnet being $2l$. An ordinary magnet cannot be said to have any definite length, as the pole is a collection of point poles, but if situated in a uniform field, the centre of force for all the parallel forces may be found, just as in a case of finding the centre of gravity of a body, and the distance between these two effective poles multiplied by the strength of either, may easily be seen to lead to the same definition of magnetic moment as was derived from the consideration of the couple in uniform field.

The Magnetometer.—The position of equilibrium of a magnetised needle suspended in two magnetic fields at right angles to each other may now be found.

H and F being the strengths of the respective fields and M the magnetic moment of the magnet, $MH \sin \theta$ is the couple tending to rotate it into the direction of H , and $MF \sin (90^\circ - \theta) = MF \cos \theta$ is the couple tending to rotate it in the direction of F (Fig. 4). The needle is therefore in equilibrium when these couples are equal, *i.e.* when

$$MH \sin \theta = MF \cos \theta$$

$$\text{or,} \quad \frac{F}{H} = \tan \theta.$$

The same result might have been obtained by remembering that the magnet will set in the direction of the resultant field, and that the resultant is inclined at an angle $\tan^{-1} \frac{F}{H}$ to the field H .

The field F may be due to a variety of causes; later, when

considering galvanometers we shall have to treat it as due to an electric current in a coil of wire, but in the present case we may consider it to be due to a bar magnet.

The magnet being situated E or W of, and at a distance d from, the

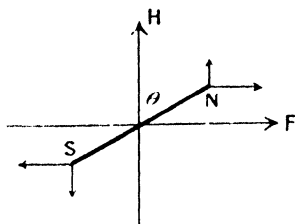

FIG. 4.

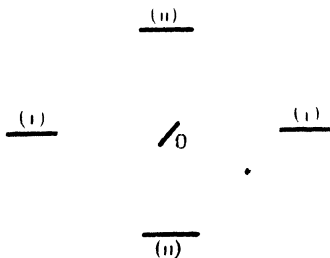

FIG. 5.

suspended needle O (Fig. 5, i), the field at O, due to the magnet, is $\frac{2M}{d^3}$, and hence the needle O will come to rest when at an angle θ to its position of equilibrium with the magnet absent.

$$\text{Then,} \quad \frac{2M}{d^3 H} = \tan \theta,$$

$$\text{or,} \quad \frac{M}{H} = \frac{d^3}{2} \tan \theta.$$

If the position (ii) be employed the magnet is situated N or S of the needle but still pointing E and W.

$$\text{Then,} \quad \frac{M}{d^3 H} = \tan \theta,$$

$$\text{or,} \quad \frac{M}{H} = d^3 \tan \theta.$$

If the length of the magnet is not so small that its square may be neglected in comparison with the square of the distance between the magnet and the needle, the more exact formulæ must be used, *i.e.*,

$$\text{Case (i)} \quad \frac{M}{H} = \frac{(d^2 - l^2)^2}{2d} \tan \theta,$$

$$\text{Case (ii)} \quad \frac{M}{H} = (d^2 + l^2)^2 \tan \theta.$$

Fig. 6 shows a common form of simple magnetometer for carrying out the measurements of deflection. The needle is a short one and is attached to a light pointer, which may be a fine piece of aluminium

wire, or a piece of glass tubing drawn out fine while soft. The suspension may be a silk fibre, or a needle-point bearing in an agate cup. The whole instrument is placed so that the ends of the pointer are at $0^\circ - 0^\circ$ on the scale when no deflecting magnet is present.

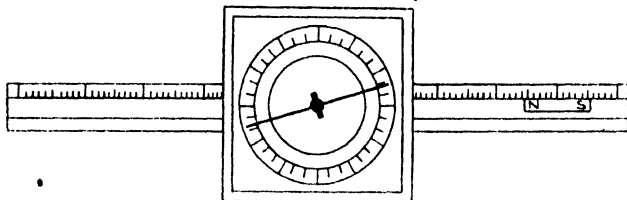

FIG. 6.

There are several sources of error, but their effects may be eliminated by taking a series of readings, provided that the errors themselves are small.

(a) The point of suspension may not be at the centre of the circular scale, and therefore both ends of the pointer are read.

(b) The *deflecting* magnet may not be symmetrically magnetised. To eliminate this error the magnet is turned over so that its N and S poles change places and the readings are again taken.

(c) The point of suspension may not be at the zero of the long straight scale, and therefore, the magnet must now be placed at an equal distance, according to the scale, on the other side of the needle and the previous readings repeated.

In this way eight readings are made and the mean is free from the errors mentioned. In making the instrument care must be taken that the pointer is at right angles to the needle. If this be not done the zero line when the instrument is set up, will not be at right angles to the meridian, and the magnet will not be in such a position that the fields due to earth and magnet are at right angles. Consequently our equations do not apply. In order to make sure that the line joining the ends of the pointer is at right angles to the magnetic axis of the needle, the needle should be suspended and the positions of the ends of the pointer marked. Then the system should be turned over and suspended from the other side. If now the pointer covers its first position it must be at right angles to the magnetic axis, but if it does not, it must be bent or in some way moved until it indicates the same reading whichever way up the needle is suspended.

By taking various distances and using Cases (i) and (ii) in turn, the relations $\frac{M}{H} = \frac{d^3}{2} \tan \theta$, and $\frac{M}{H} = d^3 \tan \theta$, or, if the magnet is not short enough, the more exact relations, may all be verified.

Again, since the quantity $\frac{M}{H}$ has been found, we may, by changing

the magnet for another, find the ratio of the two magnetic moments.

$$\frac{M_1}{H_1} = d_1^3 \tan \theta_1, \quad \frac{M_2}{H_2} = d_2^3 \tan \theta_2$$

$$\therefore \frac{M_1}{M_2} = \frac{d_1^3 \tan \theta_1}{d_2^3 \tan \theta_2}$$

or, by using the same magnet and transferring the magnetometer from one place to another, we may find the ratio of the earth's horizontal magnetic fields at the two places.

$$\frac{M}{H_1} = d_1^3 \tan \theta_1, \quad \frac{M}{H_2} = d_2^3 \tan \theta_2$$

$$\therefore \frac{H_1}{H_2} = \frac{d_2^3 \tan \theta_2}{d_1^3 \tan \theta_1}$$

The form of the moving part in the simple magnetometer does not allow of great accuracy in observing the deflection, for the thickness of the pointer itself is quite a large fraction of the size of a division of an ordinary scale of degrees, and although error due to parallax is avoided by fixing the scale on a piece of plane mirror so that the eye may always be kept vertically over the scale, the image of the pointer in the mirror and the pointer itself being made to coincide, there is still the fact that the thickness of the pointer is perhaps $\frac{1}{20}$ of the total deflection to be read. To make the scale larger would mean using a longer pointer, and thus a larger apparatus; the increase in weight of the pointer would require a stouter support, which again would mean a loss of sensitiveness. What is wanted is a long weightless pointer, and fortunately this is exactly what we have in a beam of light. As the method of a reflected beam is so largely employed in the case of galvanometers as well as for magnetometers we will consider it somewhat in detail.

Fig. 7 is a plan of the arrangement. F is the filament of some

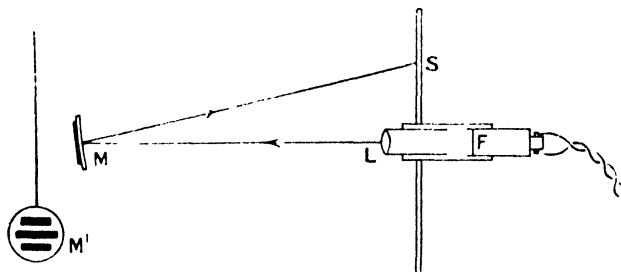

FIG. 7.

form of electric glow lamp, and its position is near the principal focus of the lens L, which is merely a condensing lens, to bring the light

from the filament into a suitable direction. The magnetometer mirror is usually concave, having a radius of curvature of about a metre, and produces upon the scale S an image of a vertical scratch upon the lens. The magnetic "needle" consists of a few pieces of magnetised watch spring attached to the back of the mirror as shown at M'. The distance LS upon the scale, where L is supposed to be the middle of the scale, is a measure of the deflection, and for many purposes this is all that we require. But if the actual angular deflection is required the distance LM from the mirror to the scale must be found; and thus remembering that the reflection occurring at the mirror doubles the rotation of the beam of light, actual rotation of mirror is $\frac{1}{2} \tan^{-1} \frac{SL}{LM}$.

In most cases the deflection is so small that the angle and its tangent do not differ greatly, and then we may take the deflection as proportional to SL. Sometimes, instead of the lamp and lens we have a telescope, and in this case (Fig. 8) the suspended mirror is plane instead of concave, the telescope being focussed upon the image of the

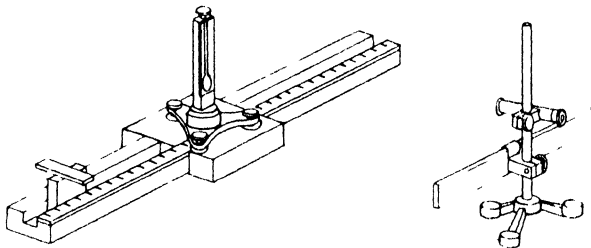

FIG. 8.

scale in the mirror. The position of the cross wire in the eye-piece as seen upon the image of the scale, enables us to observe the deflection of the needle.

Gauss's Proof of the Inverse Square Law.— The two expressions for the strength of field near a magnet, $\frac{2Ml}{(d^2 - l^2)^2}$ for Case (i) and $\frac{M}{(d^2 + l^2)^2}$ for Case (ii), are both obtained on the assumption of the inverse square law, and the resulting equations for the magnetometer, $\frac{M}{H} = \frac{(d^2 - l^2)^2}{2d} \tan \theta$ and $\frac{M}{H} = (d^2 + l^2)^2 \tan \theta$, also in their turn depend upon the truth of the law.

In either case, if we measure θ for different values of d , we may prove the constancy of $\frac{M}{H}$, and thus demonstrate the truth of the inverse square law. It should be noticed that l the half-length of the magnet is not accurately known, since the poles are not at the ends, neither

are they point poles. However, l may be found to a first approximation by taking two readings for θ and d , in one case, and equating the values of $\frac{M}{H}$ obtained. We then have an equation in l , and this may then be calculated and substituted in the other determinations. This method is only an approximation; it is better to use an exceedingly sensitive magnetometer so that reasonably accurate readings of the deflection may be made, with a magnet so small and so far distant that the relations $\frac{M}{H} = \frac{d^3}{2} \tan \theta$, and $\frac{M}{H} = d^3 \tan \theta$, may be used. With a length of magnet of 4 cms. at a distance of 50 cms. from the needle, $d^2 = 2500$ and $l^2 = 4$, and thus the error involved in neglecting l^2 in comparison with d^2 is about 0.16 per cent. In an actual case this caused a deflection of 15 scale divisions, with a probable error of one-tenth of a division. It is thus seen that the error introduced by neglecting l^2 is decidedly less than the unavoidable error in reading the deflection.

Employing the position of Case (i), Gauss observed the deflection for a given magnet at a given distance. He called this the "A" position. Next placing the magnet in the position of Case (ii), which he called the "B" position, the deflection is again observed.

$$\text{Since, } \frac{M}{H} = \frac{d^3}{2} \tan \theta_1 \dots \text{(A), and } \frac{M}{H} = d^3 \tan \theta_2 \dots \text{(B)}$$

$$\text{it follows that } \frac{\tan \theta_1}{\tan \theta_2} = 2$$

if the equations are correct. If the law of attraction were an inverse law of any other power than 2, let us say n , it may then be shown that

$$\frac{\tan \theta_1}{\tan \theta_2} = n.$$

For, referring to Fig. 1,

$$\text{Field at P due to N} = \frac{m}{(d-l)^n}$$

$$\text{Field at P due to S} = \frac{m}{(d+l)^n}$$

\therefore resultant field

$$\begin{aligned} &= m \frac{(d+l)^n - (d-l)^n}{(d^2 - l^2)^n} \\ &= m d^n \frac{\left(1 + \frac{l}{d}\right)^n - \left(1 - \frac{l}{d}\right)^n}{(d^2 - l^2)^n} \\ &= m d^n \frac{\left\{1 + \frac{nl}{d} + \frac{n(n-1)}{1 \cdot 2} \cdot \frac{l^2}{d^2} + \dots - 1 + \frac{nl}{d} - \frac{n(n-1)}{1 \cdot 2} \cdot \frac{l^2}{d^2} + \dots\right\}}{(d^2 - l^2)^n} \\ &= 2m d^n \frac{\left\{\frac{nl}{d} + \frac{n(n-1)(n-2)}{1 \cdot 2 \cdot 3} \cdot \frac{l^3}{d^3} + \dots\right\}}{(d^2 - l^2)^n} \end{aligned}$$

Now if l^2 is negligible in comparison with d^2 , then $\frac{l^2}{d^2}$ and higher powers of $\frac{l}{d}$ are negligible in comparison with $\frac{l}{d}$, and the expression for the resultant field simplifies to

$$\frac{2mln}{d^{n+1}} = \frac{nM}{d^{n+1}}$$

For the "B" position of Gauss, referring to Fig. 2 -

$$\begin{aligned} PA &= \frac{m}{(d^2 + l^2)^{\frac{n}{2}}} \\ \therefore \text{resultant field} &= \frac{m}{(d^2 + l^2)^{\frac{n}{2}}} \cdot \frac{2l}{(d^2 + l^2)^{\frac{1}{2}}} \\ &= \frac{2ml}{(d^2 + l^2)^{\frac{n+1}{2}}} \end{aligned}$$

If now l^2 in the denominator be neglected—

$$\text{Field} = \frac{2ml}{d^{n+1}} = \frac{M}{d^{n+1}}$$

and it follows that the deflections in the "A" and "B" positions of Gauss should be so related that—

$$\frac{\tan \theta_1}{\tan \theta_2} = n.$$

In the original paper of Gauss¹ the couple is calculated for any relative positions of the two magnets, and for the purpose of the experiment is reduced to the simple forms of the "A" and "B" positions. d varies from 1.1 metre to 4.0 metres and the deflection from $1^\circ 57' 24.8''$ to $0^\circ 2' 22.2''$ and the values calculated on the assumption of the law $F \propto \frac{m_1 m_2}{d^2}$ agree with the observed results to within a few seconds, thus proving that the force varies as the product of the pole strengths and inversely as the second power of their distance apart.

Lines and Tubes of Force.—A field of force such as a magnetic field, a gravitational field, or an electric field may, as we have seen, be completely defined at every point in terms of the force which would be exerted upon unit quantity of magnetic pole, matter, or, as we shall see later, electricity, if placed at each point in turn. If we imagine a free N pole placed at any point in a magnetic field, it will experience a force in the direction of the field, and on allowing it to move freely it will evidently follow a path whose direction is at each point the direction of the field. Such a path is called a line of force. The

¹ C. F. Gauss, *Poggend. Ann.*, 38, p. 591. 1833.

conception of a line of force is important, as it naturally leads us to look to the medium in which the poles are situated, for the explanation of the forces between them, and it is this fact which makes the work of Faraday of such enormous importance. If at each point of the field, lines of force be drawn so that the number of lines per square centimetre is numerically equal to the strength of field at the point, and the process continued, it may be shown that such lines are continuous curves, since they satisfy the same condition as the stream lines in the space occupied by a moving liquid; in fact, their resemblance to such lines is a very close one. Owing to the discontinuity of such lines in space, it is sometimes preferred to surround each line by a tube, such that the tubes touch each other laterally and fill the whole of space. Thus the lines or tubes of force, by their direction, indicate the direction of the field, and by the closeness with which they are packed (number per square centimetre) the strength of the field. These tubes are not identical with the Faraday tubes of force, which will be described in Chapter V.

If the tubes or lines be endowed with the property of being under tension or tending to shrink in length, and at the same time to expand laterally, just as tubes of a solid material under tensile strain would do, the forces between poles would follow; but we must be careful not to push the analogy too far. Although the idea may be a useful one in concentrating our attention upon the medium rather than the poles, we must at present keep quite an open mind as to the material structure of the medium.

The tension in the lines would tend to pull N and S together (Fig. 9, i), while the lateral push of the lines, together with the pull

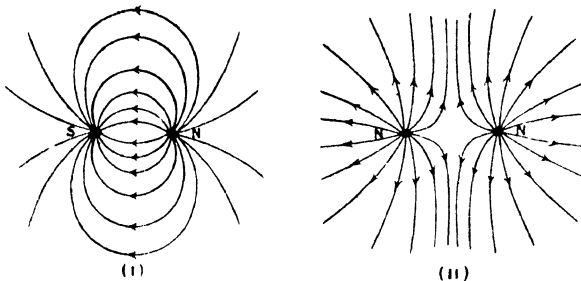

FIG. 9.

of the lines to each side, would also tend to urge N and N apart (Fig. 9, ii).

Potential.—There is another way of defining a field of force. Just as the flow of heat occurs in the direction of greatest variation in temperature, so the resultant direction of the magnetic field is that in which a quantity which we shall call *magnetic potential* varies

most rapidly. *Potential may be defined as a quantity whose space rate of variation in any direction is the strength of the field in that direction.* This idea is common to all fields of force, and most of the results obtained here may be transferred, with mere alteration of the names of the quantities, to problems in gravitation, electricity, etc.

From our definition of potential we see that if V is the potential at any point x , $\frac{dV}{dx}$ is the rate of change of potential as we pass from point to point, or the ratio of difference of potential to distance travelled, for a very small path. If then by definition of V , this quantity is the strength of field at the place considered, $F = -\frac{dV}{dx}$, the use of the negative sign being conventional and indicating that in magnetic problems the force between like poles is a repulsion, the potential diminishing as the distance from the pole increases. In the case of gravity we meet with attractions only and therefore $F = \frac{dV}{dx}$.

If a unit pole be placed at x , Fig. 10, the force experienced by it is given by the above expression, $F = -\frac{dV}{dx}$. The work done for a small movement dx is then

$$Fdx = -\frac{dV}{dx} dx = -dV, \quad \begin{matrix} \bullet \\ \text{N} \end{matrix} \quad \begin{matrix} \bullet \\ \text{A} \end{matrix} \quad \begin{matrix} \bullet \\ \text{B} \end{matrix}$$

$$\therefore V_B^A = V_A - V_B = -\int_B^A Fdx \quad \text{FIG. 10.}$$

which means that the difference in the potential between the two points A and B is the work done in carrying a unit magnetic pole from one point to the other.

Now consider the force to be due to a N pole of strength m situated at N. The strength of field at x due to this is $\frac{m}{x^2}$, or $F = \frac{m}{x^2}$,

$$V_B^A = -\int_B^A \frac{m}{x^2} dx = \left[\frac{m}{x} \right]_B^A = \frac{m}{A} - \frac{m}{B}.$$

Potential can therefore only be measured by its differences, if there is no absolute zero of potential, and consequently we cannot speak of the absolute potential of any point. Nevertheless it should be noted that there is no difference of potential between two points, that is, they are at the same potential, when a magnetic pole may be conveyed from one of the points to the other without the expenditure of work, and that at an infinite distance from all poles the forces are zero, and therefore all points are at the same potential. If we choose as the zero from which potential shall be measured, this potential at infinity, we see on putting $B = \infty$ in our equation, that $V = \frac{m}{A}$, where V is now the potential at A due to the charge m .

The potential at a point may therefore be defined as the work done in bringing a unit N pole from infinity to the point.

The potential at distance r from a N pole of strength m is $\frac{m}{r}$, and at distance r from an equal S pole it is $-\frac{m}{r}$.

Further, the work done in carrying a unit pole from any one point to any other is independent of the path by which the pole is taken: for if BCA be any path from B to A (Fig. 11), the work done is the same as in travelling from B to A' along the straight line BDA', provided that A and A' are equidistant from N. The path A'A, which is an arc of a circle, is everywhere at right angles to the field due to N, so that no work is done in carrying the unit pole

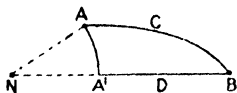

FIG. 11.

from A' to A. Hence the work for all paths such as BCA is the same as that for the path BDA', and is therefore constant.

The same conclusion is reached if we imagine the unit pole to be carried round any closed path, such as ACBDA'A. The total work done is zero, for everything is now in the same condition as at the start, and therefore the work done for the path ACB is equal and opposite to that for the path BDA'A, and is therefore equal to that for the path AA'DB. Hence whatever path we take from A to B the work done is the same in amount.

Potential due to Magnet.—Referring to Fig. 1 we see that the potential at P due to N is $+\frac{m}{d-l}$; and potential at P due to S is $-\frac{m}{d+l}$.

$$\begin{aligned} \therefore \text{Actual potential at P} &= \frac{m}{d-l} - \frac{m}{d+l} \\ &= \frac{2ml}{d^2 - l^2} \\ &= \frac{M}{d^2 - l^2} \end{aligned}$$

For a very short magnet the potential becomes $\frac{M}{d^2}$.

In Fig. 2

$$\begin{aligned} \text{Potential at P due to N} &= +\frac{m}{\sqrt{d^2 + l^2}} \\ \text{“ “ “ S} &= -\frac{m}{\sqrt{d^2 + l^2}} \end{aligned}$$

As these values are equal and opposite it follows that every point on the line bisecting the magnet at right angles is at zero potential. For

a point P on a line passing through the middle of the magnet and inclined at an angle θ to the magnet, drop perpendiculars from N and S on to OP (Fig. 12).

Then if the magnet is very small compared with the distance OP, we may without sensible error write

$$QP = NP, \text{ and, } RP = SP.$$

$$\begin{aligned} \text{Then, Potential at P} &= \frac{m}{NP} - \frac{m}{SP} \\ &= \frac{m}{QP} - \frac{m}{RP} \\ &= \frac{m}{OP - OQ} - \frac{m}{OP + OR}. \end{aligned}$$

If, as before, $OP = d$, and $NS = 2l$ we have,

$$\text{Potential at P} = \frac{m(OQ + OR)}{OP^2 - OQ^2} = \frac{m \cdot 2l \cdot \cos \theta}{d^2 - OQ^2},$$

which for a very short magnet gives—

$$\text{Potential at P} = \frac{M \cos \theta}{d^2}.$$

The same result would have been obtained if the moment of the magnet had been resolved into two components, one along OP, whose value is $M \cos \theta$, and the other perpendicular to OP, whose value is $M \sin \theta$; the potential at P due to the former is $\frac{M \cos \theta}{d^2}$ and that due to the latter is zero, the sum of the two being $\frac{M \cos \theta}{d^2}$. The

agreement of this with the previous result, justifies us in resolving the magnetic moment into two components, and indeed justification is hardly necessary since magnetic moment is a vector quantity, since it has direction as well as magnitude, and may therefore be resolved or compounded like all other vector quantities, such as force, velocity, etc.

Equipotential Lines and Surfaces.—A line or surface passing through points having the same potential is an equipotential line or surface. No work is done in carrying a pole along an equipotential line or surface, for the variation of potential along it is zero; and hence by definition of potential, it follows that there is no component of magnetic field along the line or surface, and no force tending to move a magnetic pole along it. From this reasoning it follows that lines of force and equipotential lines always cut each other at right angles, since if they did not there would be a component of the magnetic field acting along the equipotential surface.

Force between Magnets.—The resultant force experienced by a magnet in a uniform field is zero, since the forces on the N and S poles respectively are equal and opposite, the quantities of N and S pole

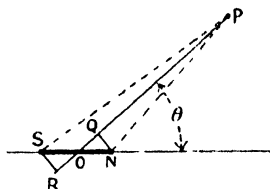

FIG. 12.

on any magnet being equal. In fact, this absence of resultant force is a most satisfactory proof of the equality of the two kinds of pole on a magnet. If a bar magnet be floated on a cork in the middle of a large vessel of water, it will experience a couple rotating it into the magnetic meridian, but the magnet will not move from the middle of the vessel, showing that there is no resultant force acting on it.

In the neighbourhood of another magnet the field is not uniform, and there will be in general a resultant force.

Consider the two short magnets NS and N'S' in Fig. 13. The field at S' due to NS is $\frac{2M}{x^2}$ where distances are measured from the middle of NS. Hence the force on S' is $\frac{2M}{x^2} \cdot m'$, where m' is the strength of pole of N'S'.

The rate of change of the field due to NS, as we increase x , is

$$\frac{d}{dx} \left(\frac{2M}{x^2} \right) = - \frac{6M}{x^3}.$$

N'S' being a small magnet of length l , decrease in field in passing from S' to N' = $-\frac{6M}{x^3} l$.

$$\therefore \text{Field at N'} = \frac{2M}{x^2} - \frac{6M}{x^3} l$$

$$\text{and force on N'} = \left(\frac{2M}{x^2} - \frac{6M}{x^3} l \right) m'.$$

Hence, resultant force on N'S' being the difference between the forces on S' and N',

$$\begin{aligned} \text{Force on N'S'} &= \frac{2M}{x^2} \cdot m' - \left(\frac{2M}{x^2} - \frac{6M}{x^3} l \right) m' \\ &= \frac{6Mm'l}{x^3} \\ &= \frac{6MM'}{x^3}. \end{aligned}$$

In an exactly similar way, we may find the resultant force on N'S' in the position shown in Fig. 14, but in this case we should note that the field is always parallel to NS, although the variation in field is at right angles to this direction.

Taking y for the distance between the magnets,

$$\text{Force on N'} = \frac{M}{y^2} \cdot m'.$$

$$\left. \begin{array}{l} \text{Rate of variation of field} \\ \text{in the direction of } y \end{array} \right\} = \frac{d}{dy} \left(\frac{M}{y^2} \right) = - \frac{3M}{y^3}.$$

$$\therefore \text{Decrease in field in passing from N' to S'} = - \frac{3M}{y^3} \cdot l,$$

FIG. 14

$$\text{and field at } S' = \frac{M}{y^3} - \frac{3M}{y^4} l.$$

$$\text{Force on } S' = \left(\frac{M}{y^3} - \frac{3M}{y^4} l \right) m'.$$

$$\begin{aligned} \text{Resultant force on } N'S' &= \frac{M}{y^3} m' - \left(\frac{M}{y^3} - \frac{3M}{y^4} l \right) m' \\ &= \frac{3MM'}{y^4}, \end{aligned}$$

and is in a direction parallel to NS.

This force on the magnet N'S' must not be confused with the couple acting on it, the value of which is $\frac{MM'}{y^4}$, and which tends to rotate it into parallelism with NS, but not to give it a motion of translation. The existence of the resultant force explains the following apparent paradox: If the two magnets NS and N'S' be placed on a floating platform, there is a couple acting on NS due to the presence of N'S', the value of which is $\frac{2MM'}{y^4}$, and N'S' at the same time experiences a couple $\frac{MM'}{y^4}$ due to the presence of NS. Since these couples are not equal and opposite, it would at first sight appear that there is a resultant couple acting on the platform due to the interaction of the magnets, which would make the platform rotate continuously. Such a rotation would involve the continuous expenditure of energy without any corresponding supply, which is contrary to experience. But the fallacy consists in neglecting the force of translation $\frac{3MM'}{y^4}$ acting upon the magnet N'S' at right angles to the line joining the magnets, which is equivalent to a couple $\frac{3MM'}{y^4} \times y = \frac{3MM'}{y^3}$. An inspection of Fig. 14 shows us that this couple would produce an anti-clockwise rotation, while the former would produce a clockwise rotation, so that the difference, or $\frac{2MM'}{y^4}$, is the resultant couple in an anti-clockwise direction. This is equal and opposite to the couple on NS, which is clockwise, so that the two are in equilibrium and the paradox disappears.

Field due to Small Magnet.—The field at the point P due to a very short magnet may be found by resolving the moment M along OP, and at right angles to OP. The former component will produce a field $\frac{2M \cos \theta}{r^3}$ represented by the vector PQ (Fig. 15), and the latter component, the field $\frac{M \sin \theta}{r^3}$ represented by PT. The resultant field is

$$PR = \sqrt{PQ^2 + PT^2} = \frac{M}{r^3} \sqrt{4 \cos^2 \theta + \sin^2 \theta} = \frac{M}{r^3} \sqrt{1 + 3 \cos^2 \theta},$$

and its inclination to the line OP is RPQ . Now,

$$\tan RPQ = \frac{PT}{PQ} = \frac{\sin \theta}{2 \cos \theta} = \frac{1}{2} \tan \theta.$$

Hence to find the direction of the resultant field at any point P , make the angle $QPA = \theta = POV$ and drop perpendicular AQ upon PQ (Fig. 15). Bisect AQ in R and join PR . PR is then the direction of the field at P . Or if the perpendicular PV be drawn and bisected

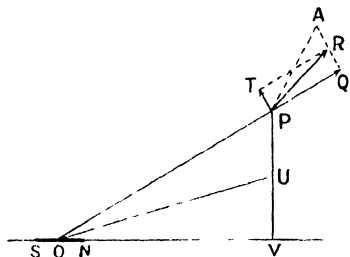

FIG. 15.

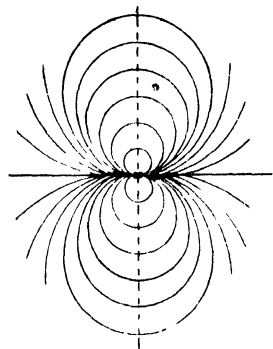

FIG. 16.

at U , angle UOV is equal to the angle RPQ made between the direction PR of the field and that of the radius vector OP , and it is the same at all points along OP . By drawing the direction by means of short lines at a number of points along OP and again for a number of different radii, the direction of the field at a number of points is known, and the lines of force may be drawn with fair accuracy.

In Fig. 16, the lines of force for an extremely small magnet have been drawn in this way.

CHAPTER II

TERRESTRIAL MAGNETISM

Magnetic Elements.—Great importance attaches to an accurate knowledge of the condition of the magnetic field at the surface of the earth, both to the navigator for practical purposes, and to the investigator who attempts to describe and account for the magnetic state of the earth. This implies a knowledge, at every instant, of the magnitude and direction of the field at every place, but it is much more convenient to represent the field at any place by means of certain elements or components, than to express it in terms of the resultant field and its direction. For the purpose of representation we choose those elements that lend themselves most readily to experimental determination. These are:—the *Declination* or angle which the magnetic meridian makes with the geographical meridian, α (Fig. 17); the *Horizontal Component* of the earth's magnetic field, H , and the *Dip* or angle which the resultant field makes with the horizontal, θ , and it will be seen that when these elements are known the field is completely determined, and may then be represented in terms of any other co-ordinates. But it must be borne in mind that the field is always changing, so that the elements undergo variations; these will be considered later.

Magnetic Meridian.—We have already seen that a suspended magnetic needle sets in a certain direction, approximately N and S. A vertical plane passing through the magnetic axis of a freely suspended needle is called the magnetic meridian. This does not in general coincide with the geographical meridian, and its position may be roughly determined by observing the direction in which a compass needle will set; but since the magnetic axis of the needle may not coincide with its axis of symmetry or geometric axis, the needle should always be turned over after the first observation has been made, and suspended from the other side. If the geometric axis makes an angle with the magnetic axis the needle will point E or W of magnetic

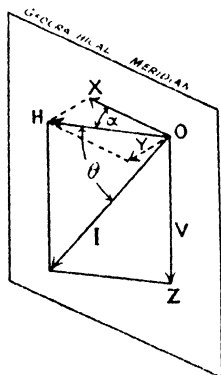

FIG. 17.

north, but on suspending it with its other face upwards it will make the same angle on the other side of magnetic north. The direction of the magnetic axis and of the magnetic meridian will then be found by bisecting the angle between the two positions of the axis of symmetry. In Fig. 18, NS is the magnetic meridian. For many purposes the

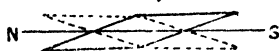

FIG. 18.

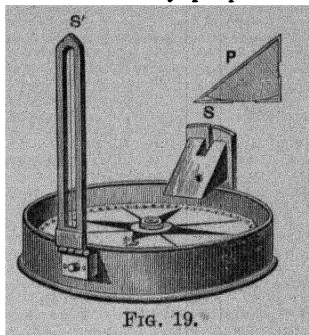

FIG. 19.

prismatic compass (Fig. 19) may be usefully employed to find approximately the direction of the magnetic meridian. Some distant object in a known geographical direction is sighted by means of the slot S and the wire S'. By means of the right-angled prism shown in section at P the position of the image of the wire S' may be read upon the scale of the compass card. The magnetic direction of the distant object being thus found, and its geographical direction being known, the position of the magnetic meridian is determined.

Declination.—The angle between the magnetic meridian and the geographical meridian is usually known as the magnetic declination; for nautical purposes it is called the Variation of the Compass, meaning its variation from a true north-and-south direction. In Fig. 17 the plane containing H, I, and V is the magnetic meridian, and consequently the angle a is the declination. In the last described experiment the declination is found, but for its more accurate determination the Kew magnetometer, which will be described later, is employed.

Dip. A perfectly freely suspended magnet would not in general set in a horizontal direction, but along the line of the greatest strength of field. This is represented by I in Fig. 17, and the angle θ between it and the horizontal is called the *magnetic dip*. A perfectly freely suspended magnet is of course an ideal which is unattainable, since the mechanical support must influence the angle at which the needle will set; in fact, a compass needle is deliberately, although perhaps unconsciously, placed in its suspension in such a way that it sets horizontally, and any tendency to dip is neutralised by suspending it from a point which is not its centre of gravity, so that the result of all the forces acting on it is to cause it to remain horizontal. If, however, a needle be mounted on a fine straight axle resting on horizontal knife-edges, and if the axle

pass through the centre of gravity of the needle, it can rotate in a vertical plane, and if this plane coincide with the magnetic meridian the needle will set with its magnetic axis along I, Fig. 17, and its inclination to the horizontal will be the dip. The experimental determination of the dip will be described later.

So far we have only determined the direction in space of the resultant field I; if, then, we can find its magnitude or that of any component of it in a known direction, the field becomes completely determined at that particular locality. By far the most convenient component to determine is H, the horizontal component, and then knowing this, the vertical component V may be calculated. For from Fig. 17,

$$\frac{V}{H} = \tan \theta$$

and again, the total intensity I may be found,

$$I^2 = H^2 + V^2.$$

For some purposes it is convenient to refer the earth's field to three rectangular axes: OX, a horizontal line in the geographical meridian, true N and S; OY, a horizontal line perpendicular to the geographical meridian, true E and W; and OZ a vertical line.

Then taking X, Y, and Z as the components of the earth's magnetic field in these directions,

$$\begin{aligned} X &= H \cos \alpha = I \cos \theta \cos \alpha \\ Y &= H \sin \alpha = I \cos \theta \sin \alpha \\ Z &= V = I \sin \theta. \end{aligned}$$

Vibrating Magnet.—Although there are several methods of determining H, that which is most frequently employed is the magnetometric method, its chief advantage over other methods being that it does not involve the use or measurement of electric currents. We have seen in Chapter I. how the ratio of M to H may be determined for a given bar magnet, in terms of the deflection of a suspended magnetic needle, at a given distance from the magnet. The absolute values of M and H, however, cannot be determined by the magnetometer, but only their ratio. A further experiment is required, to give us some other relation between M and H.

Whenever a suspended magnet makes an angle θ with its position of equilibrium, a couple $MH \sin \theta$ acts on it (see p. 5) which tends to restore it to that position. Thus the magnet must have an angular acceleration, and we may express the couple acting on it as the product of its moment of inertia I and the angular acceleration $\frac{d^2\theta}{dt^2}$.

Then $I \frac{d^2\theta}{dt^2} + MH \sin \theta = 0$, since the algebraic sum of the couples acting on it must be zero, the effect of the forces due to the friction, etc., in this case being negligible. Further, if the value

of θ is never more than a few degrees, the angle itself in circular measure may be taken instead of its sine, and our equation is therefore—

$$I \frac{d^2\theta}{dt^2} + MH\theta = 0.$$

As this type of equation will frequently occur, we will proceed to solve it. First write it in the form—

$$\frac{d^2\theta}{dt^2} + k^2\theta = 0,$$

where k^2 is substituted for $\frac{MH}{I}$.

It is a homogeneous equation, and we can therefore obtain a solution in the form $\theta = e^{at}$.

Differentiating this last equation twice, we have—

$$\frac{d^2\theta}{dt^2} = a^2 e^{at},$$

and substituting the values for θ and $\frac{d^2\theta}{dt^2}$ in the equation, we have—

$$\begin{aligned} a^2 e^{at} + k^2 e^{at} &= 0 \\ \therefore a^2 &= -k^2, \text{ and, } a = \pm \sqrt{-k^2} \\ &= \pm k\sqrt{-1}. \end{aligned}$$

Thus there are two particular solutions—

$$\theta = A e^{k\sqrt{-1}t}, \text{ and, } \theta = B e^{-k\sqrt{-1}t},$$

and the most general equation to the motion of the needle is—

$$\theta = A e^{k\sqrt{-1}t} + B e^{-k\sqrt{-1}t}$$

where **A** and **B** are two constants that can be determined from the conditions of the problem. Thus, if the time be reckoned from the instant at which the needle is in the direction of the meridian, $\theta = 0$ when $t = 0$,

$$\therefore A + B = 0, \text{ or, } A = -B,$$

and the equation may be written—

$$\theta = A(\epsilon^{k\sqrt{-1}t} - \epsilon^{-k\sqrt{-1}t}).$$

Again, the angular velocity of the needle is—

$$\frac{d\theta}{dt} = k\sqrt{-1} A(\epsilon^{k\sqrt{-1}t} + \epsilon^{-k\sqrt{-1}t}),$$

and if this is ω when t and θ are zero—

$$\begin{aligned} A &= \frac{\omega}{2k\sqrt{-1}}, \\ \therefore \theta &= \frac{\omega}{k} \left(\frac{\epsilon^{k\sqrt{-1}t} - \epsilon^{-k\sqrt{-1}t}}{2\sqrt{-1}} \right). \end{aligned}$$

The term in brackets is the well-known exponential form of the sine of the angle kt , and so writing $\frac{\omega}{k} = \theta_0$, we have—

$$\theta = \theta_0 \sin kt.$$

Thus we see that the needle executes simple harmonic oscillations, one complete oscillation occurring in time $\frac{2\pi}{k}$; for, on increasing t by this value we get—

$$\theta = \theta_0 \sin k\left(t + \frac{2\pi}{k}\right) = \theta_0 \sin (kt + 2\pi) = \theta_0 \sin kt$$

and thus the motion is repeated after intervals of time $\frac{2\pi}{k}$.

Calling the periodic time T , we have $T = \frac{2\pi}{k}$, and remembering that $k^2 = \frac{MH}{I}$, we see that $T = 2\pi\sqrt{\frac{I}{MH}}$.

Determination of M and H.—The moment of inertia I of the magnet may be found from its mass and linear dimensions. In the case of a rectangular magnet, $I = \text{mass} \times \frac{\text{length}^2 + \text{breadth}^2}{12}$, and for a cylindrical magnet, $I = \text{mass} \times \left(\frac{\text{length}^2}{12} + \frac{\text{radius}^2}{4}\right)$. The time of oscillation is observed by suspending the magnet in the locality occupied by the needle in the magnetometer experiment and observing the time of a number of swings. Then from our equation we have $MH = \frac{4\pi^2 I}{T^2}$, and the magnetometer experiment gave us $\frac{M}{H}$.

Combining these we have, $MH \times \frac{M}{H} = M^2$, or $MH \div \frac{M}{H} = H^2$, so that both M and H are now determined in absolute measure.

Comparison of Fields by Vibration.—It may be noticed that $H = \frac{4\pi^2 I}{MT^2}$, and hence, that if the same magnet be employed on different occasions I and M will be the same, so that, $\frac{H_1}{H_2} = \frac{T_2^2}{T_1^2}$, or if n be the number of oscillations made by the magnet in a given time, $n_1 = \frac{T_2}{T_1}$, so that $\frac{H_1}{H_2} = \frac{n_2^2}{n_1^2}$. This gives rise to a method of comparing the strengths of magnetic field at two given times or places; for if the same magnet be allowed to oscillate on the two occasions and the number of oscillations made in equal times observed, the ratio of the two field strengths is known. But it must be noticed that the fibre used to suspend the

magnet must be as nearly as possible torsionless, and further, the magnet must be carefully preserved from ill treatment, mechanical or thermal, or its magnet moment will not be the same on the two occasions.

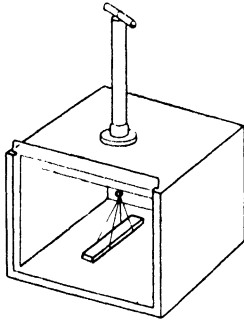

FIG. 20.

To determine the time of swing, the magnet is suspended in a vibration box (Fig. 20) by means of a silk support, the magnet being held in a double loop as shown. It is advisable to suspend some bar of approximately the same weight as the needle before placing the magnet in position, in order that any torsion in the thread may be removed. If the suspension head be turned so that the solid at rest lies approximately in the meridian, then on replacing it by the magnet the suspending fibre will be very nearly free from torsion. The position of equilibrium of the magnet may be marked

upon the front and back glass walls of the box and the magnet then given a small oscillation. At the instant of passing the equilibrium position in one direction, the time by the chronometer is noted or the stop-watch is started. At the passage across the equilibrium position in the same direction after fifty or one hundred swings the time is again noted, and the time for one oscillation may then be found by division.

Equivalent Length of Magnet.—Employing the magnetometer (p. 9) the deflection may be found as there described, and the mean value of $\frac{M}{H}$ found from the expression $\frac{M}{H} = \frac{d^3}{2} \tan \theta$ for the “A” position of Gauss, or $\frac{M}{H} = d^3 \tan \theta$ for the “B” position. The use of these approximate formulæ is justified if l^2 is negligible in comparison with d^2 , or $\frac{l^2}{d^2}$ is a less percentage of unity, than the percentage error introduced in making the observations of deflection. The difficulty arises that if d is made very great, the deflection may be so small that the error in its measurement is considerable. Hence it is desirable to employ the more exact formulæ—

$$\frac{M}{H} = \frac{(d^2 - l^2)^2}{2d} \tan \theta, \text{ and, } \frac{M}{H} = (d^2 + l^2)^{\frac{3}{2}} \tan \theta,$$

but unfortunately l is unknown, the poles being distributed over a large surfaces of the magnet. The effective value of L or $2l$, the length of the magnet, may be found from two measurements of $\frac{d^3}{2} \tan \theta$, the approximate value of $\frac{M}{H}$, for two distances from the suspended needle,

and may then be applied as a correction to obtain the true value of $\frac{M}{H}$.

Calling $\frac{M}{H}$ the true value, $\left(\frac{M}{H}\right)_1$ the value found for distance d_1 , by using the approximate formula, and $\left(\frac{M}{H}\right)_2$ that for distance d_2 , we see that —

$$\begin{aligned} \frac{M}{H} &= \frac{(d_1^2 - l^2)^2}{2d_1} \tan \theta_1 = \frac{d_1^4 \left(1 - \frac{l^2}{d_1^2}\right)^2}{2d_1} \tan \theta_1 \\ &= \left(1 - \frac{l^2}{d_1^2}\right)^2 \frac{d_1^3}{2} \tan \theta_1 \\ &= \left(1 - \frac{l^2}{d_1^2}\right)^2 \left(\frac{M}{H}\right)_1 \\ &= \left(\frac{M}{H}\right)_1 \left(1 - \frac{2l^2}{d_1^2} + \frac{l^4}{d_1^4}\right) \end{aligned}$$

Since $\frac{l^2}{d_1^2}$ is small, we may reasonably say that $\frac{l^4}{d_1^4}$ is negligible, and remembering that $L = 2l$,

$$\frac{M}{H} = \left(\frac{M}{H}\right)_1 \left(1 - \frac{L^2}{2d_1^2}\right).$$

Similarly,

$$\frac{M}{H} = \left(\frac{M}{H}\right)_2 \left(1 - \frac{L^2}{2d_2^2}\right),$$

$$\therefore \left(\frac{M}{H}\right)_1 - \left(\frac{M}{H}\right)_2 \frac{L^2}{2d_1^2} = \left(\frac{M}{H}\right)_2 - \left(\frac{M}{H}\right)_2 \frac{L^2}{2d_2^2}$$

$$\text{and, } \frac{L^2}{2} = \frac{\left(\frac{M}{H}\right)_1 - \left(\frac{M}{H}\right)_2}{\left(\frac{M}{H}\right)_1 \frac{1}{d_1^2} - \left(\frac{M}{H}\right)_2 \frac{1}{d_2^2}}.$$

The quantity on the right being determined from measurements at two distances, we know the correction $\left(1 - \frac{L^2}{2d^2}\right)$ to be applied to the approximate formula to obtain the true value—

$$\text{thus, } \frac{M}{H} = \left(\frac{M}{H}\right)_1 \left(1 - \frac{L^2}{2d_1^2}\right) = \left(\frac{M}{H}\right)_2 \left(1 - \frac{L^2}{2d_2^2}\right).$$

The quantity $\frac{L^2}{2}$ may be taken as one constant P, and if in addition

$$A_1 = \left(\frac{M}{H}\right)_1 \text{ and } A_2 = \left(\frac{M}{H}\right)_2$$

$$P = \frac{A_1 - A_2}{\bar{d}_1^2 - \bar{d}_2^2}, \quad \text{and,} \quad \frac{M}{H} = \left(\frac{M}{H}\right)_1 \left(1 - \frac{P}{d_1^2}\right).$$

For the "B" position of Gauss the correction may be applied in a similar manner -

$$\begin{aligned} \frac{M}{H} &= (d^2 + l^2)^3 \tan \theta = d^3 \left(1 + \frac{l^2}{d^2}\right)^3 \tan \theta \\ &= \left(\frac{M}{H}\right)_1 \left(1 + \frac{l^2}{d_1^2}\right)^3 \\ &= \left(\frac{M}{H}\right)_2 \left(1 + \frac{l^2}{d_2^2}\right)^3, \end{aligned}$$

$$\begin{aligned} \therefore \left(\frac{M}{H}\right)_1 \left(1 + \frac{3}{2} \cdot \frac{l^2}{d_1^2} + \frac{3}{1} \cdot \frac{1}{2} \cdot \frac{l^4}{d_1^4} + \dots\right) \\ = \left(\frac{M}{H}\right)_2 \left(1 + \frac{3}{2} \cdot \frac{l^2}{d_2^2} + \frac{3}{1} \cdot \frac{1}{2} \cdot \frac{l^4}{d_2^4} + \dots\right). \end{aligned}$$

Neglecting $\frac{l^4}{d^4}$ and higher power of $\frac{l}{d}$, we have as before -

$$\left(\frac{M}{H}\right)_1 \left(1 + \frac{3}{2} \cdot \frac{l^2}{d_1^2}\right) = \left(\frac{M}{H}\right)_2 \left(1 + \frac{3}{2} \cdot \frac{l^2}{d_2^2}\right)$$

Substituting L for $2l$ we have—

$$\begin{aligned} \left(\frac{M}{H}\right)_1 \left(1 + \frac{3}{8} \cdot \frac{L^2}{d_1^2}\right) &= \left(\frac{M}{H}\right)_2 \left(1 + \frac{3}{8} \cdot \frac{L^2}{d_2^2}\right) \\ \therefore \frac{3}{8} L^2 &= \frac{\left(\frac{M}{H}\right)_2 - \left(\frac{M}{H}\right)_1}{\left(\frac{M}{H}\right)_1 \cdot \frac{1}{d_1^2} - \left(\frac{M}{H}\right)_2 \cdot \frac{1}{d_2^2}} = P. \end{aligned}$$

$$\therefore \frac{M}{H} = \left(\frac{M}{H}\right)_1 \left(1 + \frac{P}{d_1^2}\right) = \left(\frac{M}{H}\right)_2 \left(1 + \frac{P}{d_2^2}\right).$$

Thus, from the deflection produced at any two distances of the magnet, the true value of $\frac{M}{H}$ may be found; or, if it is desired, the equivalent length L of the magnet can be obtained. If this be found for any magnet, future determinations of $\frac{M}{H}$ may be made by observing the deflection for one distance of the deflecting magnet.

The Kew Magnetometer.—The form of needle used in the Kew pattern of magnetometer is shown in Fig. 21. It consists of a steel tube A having a fine transparent scale S at one end and a lens L at the other, the scale being at the principal focus of the lens. The magnet is thus a collimator, and when the telescope is focussed for infinity and placed

co-axially with the magnet, an image of the fine scale will be seen in the focal plane of the telescope. If the suspension fibre be freed from

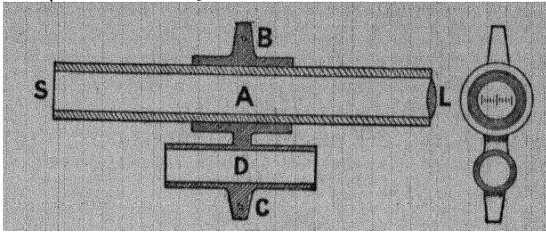

FIG. 21.

(From Watson's "Textbook of Physics.")

torsion and the body of the magnetometer (Fig. 22) rotated until the image of the middle division of the scale coincides with the cross wire of the telescope, the azimuth of the telescope, as indicated by the horizontal circular scale, gives the direction of the geometric axis of the magnet. The magnet is then turned over and the position of the geometric axis with reference to the horizontal scale again determined. The mean of the two positions is the azimuth of the magnetic meridian upon this scale. If the azimuth of the geographical meridian also be found, the difference between the two gives us the magnetic declination. The geographical meridian is found by observing the image of the sun produced by the mirror *m* in passing the cross wire of the telescope, it having been previously adjusted so that its axis is horizontal, and the plane in which the normal travels as the mirror is turned contains the optic axis of the telescope. From the observed time of the sun's passing the cross wire, knowing the longitude of the place of observation and the

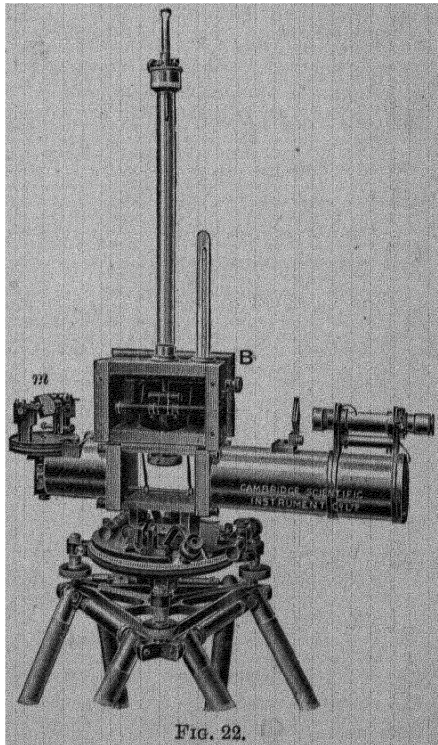

FIG. 22.

equation of time, the direction of the sun at the time of observation is known, and thus the direction of true N and S also.

The period of oscillation of the magnet may now be found with the arrangement just described. The magnet is given a small oscillation, and the time for 100 transits of the image of the middle scale division across the cross wire of the telescope in one direction, either from left to right, or right to left, is observed. This gives the time for 100 oscillations, from which the time of one oscillation must be found. This must be corrected, for the fact that the fibre, although very fine, yet exerts some controlling couple on the magnet, and therefore shortens the period of oscillation. If the suspension head be rotated through 90° , an angular deviation of α radian is produced and may be observed then $\frac{\pi}{2} - \alpha$ is the twist in the suspension, and

$$c \left(\frac{\pi}{2} - \alpha \right) = MH \sin \alpha = MH\alpha,$$

where c is the couple exerted by the fibre for one radian twist, and α is the very small deflection produced by 90° rotation of the torsion head.

When the magnet is at an angle θ to the magnetic meridian, the restoring couple is now $(MH + c)\theta$ instead of $MH\theta$, and the time of oscillation found on page 23, will therefore be $2\pi\sqrt{\frac{I}{MH + c}}$ instead of $2\pi\sqrt{\frac{I}{MH}}$. It follows that from the observed time of swing we have really obtained

$$\frac{4\pi^2 I}{T^2} = MH + c = MH + \frac{MH\alpha}{\frac{\pi}{2} - \alpha} = MH \left(1 + \frac{\alpha}{\frac{\pi}{2} - \alpha} \right)$$

$$\therefore MH = \frac{4\pi^2 I}{T \left(1 + \frac{\alpha}{\frac{\pi}{2} - \alpha} \right)},$$

and we see that the square of the observed time of swing must be multiplied by the factor $\left(1 + \frac{\alpha}{\frac{\pi}{2} - \alpha} \right)$ in order to obtain the corrected

value of MH .

Two further corrections must be applied: one for the fact that the magnetic moment of the magnet changes with temperature, and the other for the fact that, being in the earth's magnetic field, its magnetic moment is greater than when, as in the deflection experiment, it is in an E and W direction. The first of these corrections is made by reducing the moment to that at 0° C. by means

of the factor $\{1 + q(t - t_0)\}$; thus $M_0 = M_t\{1 + q(t - t_0)\}$, the magnetic moment decreasing with rise of temperature: q must be found by a previous experiment for each individual magnet. The second correction is applied by means of a factor in which it is assumed that the alteration in magnetic moment is proportional to the field in which the magnet is situated. This assumption is justified if the field is small, and further, the change in magnetic moment is proportional to the volume of the magnet, and depends on the position of the magnet in relation to the field, and the material of which the magnet is made (see Chapter X.); thus if M_0 is the moment in zero field or whenever the magnet is situated at right angles to the field, and M that when parallel to the field, $M = M_0 + aVH_0$, where a is some constant depending on the nature of the material of the magnet. V is also constant, so calling $aV = \mu$ we have $M = M_0 + \mu H$.

$$\therefore MH = M_0H + \mu H^2 = M_0H\left(1 + \mu \frac{H}{M_0}\right).$$

$\frac{H}{M_0}$ is always very small, and hence, when the whole quantity $\mu \frac{H}{M_0}$ is small,

$$M_0H = MH\left(1 - \mu \frac{H}{M_0}\right).$$

$\frac{H}{M_0}$ is known from the deflection experiment, and μ is a constant for a magnet of any given size or material, so that the quantity MH as found from the vibration experiment may be corrected by means of the factor $\left(1 - \mu \frac{H}{M_0}\right)$.

The square of the time of oscillation may thus be corrected for torsion of fibre, temperature, and alteration of moment due to the magnetic field, by a single factor, and

$$T_0^2 = T^2 \left\{ 1 + \frac{a}{\frac{\pi}{2} - a} - q(t - t_0) + \mu \frac{H}{M_0} \right\}.$$

The moment of inertia I of the magnet and carrier may be found by adding a body of known moment of inertia and redetermining the time of oscillation. A brass cylinder which just fits into the space D of the carrier (Fig. 21) is employed. If I_1 is the moment of inertia of the cylinder, $I_1 = m\left(\frac{l^2}{12} + \frac{r^2}{4}\right)$, and the time of vibration is now

$$T_1 = 2\pi \sqrt{\frac{I + I_1}{MH}}.$$

$$T^2 = 4\pi^2 \cdot \frac{I}{MH}, \text{ and, } T_1^2 = 4\pi^2 \frac{I + I_1}{MH},$$

$$\therefore \frac{I + I_1}{I} = \frac{T_1^2}{T^2}$$

from which,

$$I = I_1 \frac{T^2}{T_1^2} - T^2.$$

I being found in this way, the value may be used for any number of vibration experiments with the same magnet, since it is a mechanical constant and is independent of the magnetic condition of the magnet.

To perform the deflection experiment for the determination of M , the box B (Fig. 22) is removed, and a small magnet with mirror attached is suspended by a long fibre. The telescope is focussed upon the image of the scale S, Fig. 23, in this mirror, and the collimator magnet of the vibration experiment is placed in the V rests at M

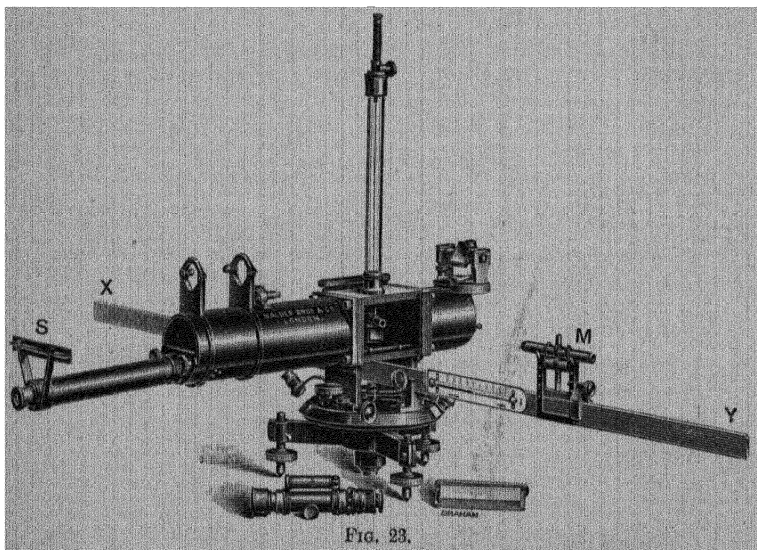

upon the carrier, which may be set at different distances from the mirror needle by moving it along the graduated bar XY. In this experiment the deflection of the needle is not observed, as we should then have to apply a correction for the torsion introduced into the fibre when the needle rotates, but instead, the body of the instrument is rotated until the middle division of the scale coincides with the cross wire of the telescope, and this rotation is measured by taking the difference between the various readings upon the horizontal circular scale with and without the presence of the collimator magnet M. In this

case, field due to magnet NS is $\frac{2M}{d^3}$, and couple on needle is $\frac{2M}{d^3} m$, where m is the magnetic moment of the needle (Fig. 24).

Restoring couple due to earth's field H , is $Hm \sin \theta$.

$$\therefore \frac{2M}{d^3} m = Hm \sin \theta$$

$$\frac{M}{H} = \frac{d^3}{2} \sin \theta.$$

Thus we must replace the tangent by the sine in our previous calculations, but otherwise no change is made. This is known as the "sine" method, and its chief advantage lies in the fact that when the suspended magnet is in equilibrium, the observing telescope and the needle are in the same relative positions as for the zero position, and hence there is no twist in the suspension fibre.

The collimator magnet M is then reversed end for end and the deflection again observed, to correct for want of symmetry in the distribution of poles on the magnet, and the magnet is then moved to a position at the same distance on the other side of the suspended needle and the observations repeated. Another distance is then chosen and the readings made again, so that the correction for length of the magnet M as described on p. 25 may be applied. The temperature correction is applied as in the vibration experiment.

Determination of Dip.—The Kew pattern of dip circle is shown in Fig. 25. The dip needle itself is a thin steel magnet AB provided with a fine steel axle which rests on agate knife-edges shown at K, K' .

It is carried by the V supports L, L' which may be raised and lowered by turning the milled head E . In making a reading, the observer must continually raise the needle and lower it, in order to bring the axle constantly to the centre of the circular scale, since as the needle swings it rolls upon the axle and travels from the centre of the scale. The body of the instrument may be rotated about a vertical axis and its azimuth read upon the horizontal scale II . The position of the needle with reference to the vertical or actual dip circle is found by rotating the arm which carries the microscopes M, M' until the cross wires appear to coincide with the tips of the needle, the verniers being then read.

To begin observations, the instrument is levelled and then rotated about its vertical axis until the needle sets vertically, *i.e.* reads 90° — 90° . The plane in which the needle rotates is then at right angles to the magnetic meridian. For, let the plane

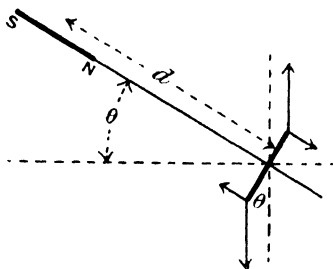

FIG. 24.

AB (Fig. 26) be the plane of rotation of the needle, and let it make angle δ with the magnetic meridian HB.

Resolving the magnetic field I into three components X and Z in

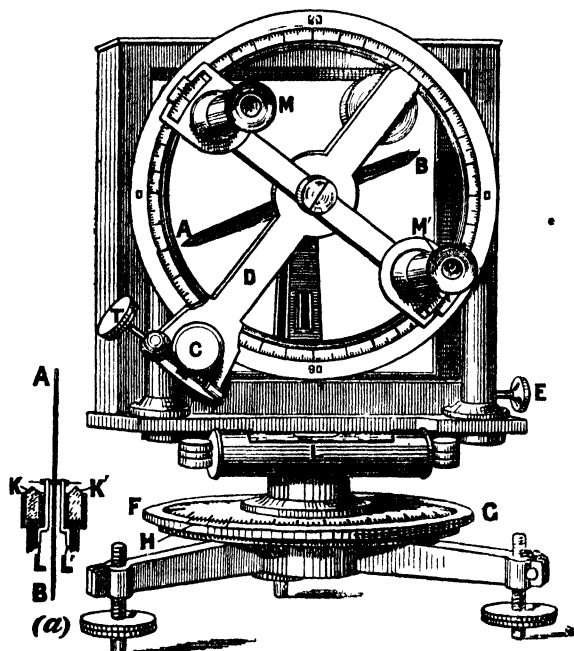

FIG. 25.

(From Watson's "Textbook of Physics")

this plane, and Y at right angles to it, X being horizontal and Z vertical,

$$X = H \cos \delta = I \cos \theta \cos \delta$$

$$Y = H \sin \delta = I \cos \theta \sin \delta$$

$$Z = I \sin \theta.$$

Y , being in the direction of the axle, will not exert any turning moment about it, and the needle will therefore set along the resultant of X and Z . If we call θ' the angle that this resultant makes with the horizontal,

$$\tan \theta' = \frac{Z}{X} = \frac{I \sin \theta}{I \cos \theta \cos \delta} = \frac{\tan \theta}{\cos \delta}$$

θ is the true dip given by $\tan \theta = \frac{I \sin \theta}{I \cos \theta} = \frac{Z}{H}$, and is for the present, treated as a constant quantity at the given locality.

$$\text{If now, } \theta' = 90^\circ, \tan \theta' = \infty$$

$$\therefore \cos \delta = 0, \text{ and } \delta = 90^\circ$$

Thus the plane of rotation of the dipping needle is at right angles to the meridian, and on rotating the instrument about its vertical axis through 90° as determined by the horizontal circle, the plane of rotation of the needle will be brought into the meridian, and the measured dip will then be the true dip. Note that if $\delta = 0$, $\cos \delta = 1$, and $\tan \theta' = \tan \theta$.

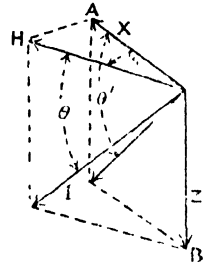

FIG. 26.

Another method of using the circle consists in measuring the dip in any two positions of the circle the angle between which is 90° . The instrument is clamped to its vertical axis and the position upon the scale FG noted, and the dip in this position is found.

If δ is the angle between the plane of rotation of the needle and the magnetic meridian, and θ_1 the observed dip, we have already seen

that $\tan \theta_1 = \frac{\tan \theta}{\cos \delta}$. On now rotating the instrument through 90° , and again observing the dip θ_2 , we have—

$$\tan \theta_2 = \frac{\tan \theta}{\cos (\delta + 90^\circ)} = -\frac{\tan \theta}{\sin \delta}$$

$$\therefore \frac{1}{\tan^2 \theta_1} = \frac{\cos^2 \delta}{\tan^2 \theta'} \quad \text{and,} \quad \frac{1}{\tan^2 \theta_2} = \frac{\sin^2 \delta}{\tan^2 \theta'}$$

Adding, we get
$$\frac{1}{\tan^2 \theta} = \frac{1}{\tan^2 \theta_1} + \frac{1}{\tan^2 \theta_2}$$

Errors in determining Dip.—In measuring the dip there are several errors to be eliminated, and if these are small, the mean of the following readings will give the true dip:—

(i) The positions of the two ends of the needle are read, in order to correct for the fact that the centre of rotation of the needle may not be at the centre of the vertical circle (Fig. 27 (i)).

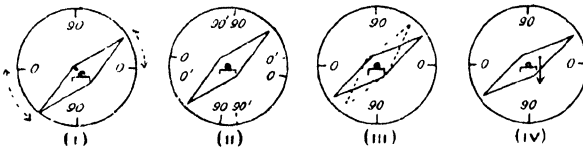

FIG. 27.

(ii) The instrument is rotated through 180° about the vertical axis, and the two previous readings repeated, since the $0^\circ-0^\circ$ line of the vertical scale may not be horizontal and the apparent dip, if too great in the first position, will be too small by an equal amount in the second position. The zero line after rotating the instrument through 180° is $0'-0'$ (Fig. 27 (ii)).

(iii) The needle is turned over on its bearings and the previous four readings repeated, because the magnetic axis of the needle may not coincide with its geometric axis as described on p. 20 (Fig. 27 (iii)).

(iv) The magnet is remagnetised in the opposite direction, so that the end which dipped previously now points upwards. This is the only way of correcting for the fact that the axis of rotation may not pass through the centre of gravity of the needle, a small couple due to gravity causing the needle to rotate from the position of true dip (Fig. 27 (iv.)). The previous eight readings are repeated and the mean of the whole sixteen taken as the true dip. The individual readings should never differ by more than a degree from the mean, if the instrument is properly constructed.

Magnetic Maps.—The three magnetic elements, Declination, Dip, and Horizontal Intensity, having been observed at a great number of stations, the question arises as to how the results may be represented to the greatest advantage. Many methods have been employed, but the most frequent is to draw lines upon a map, passing through all points for which one of the magnetic elements has a common value. Thus three maps are required, one for the representation of each element, or the three may be represented upon one map. Lines passing through points having the same value of the declination are called *Isogonal lines*, those passing through points for which the dip is the same are *Isoclinical lines*, and *Isodynamic lines* are those passing through points for which the horizontal intensity is the same.

In Fig. 28 the isogonals for the year 1910 are represented on a map of the world drawn on Mercator's projection. They converge towards four points upon the earth's surface, namely, the two graphical poles, and two other points, called the magnetic poles. There are two chief *agonic* lines or lines of no declination, at all points of which the compass points towards the geographical poles. One of these agonic lines passes from the magnetic north pole to the geographic south pole by way of America and the Atlantic Ocean, and the other from the geographic north pole to the magnetic south pole through Eastern Europe, Arabia, the Indian Ocean and Australia. Along some line joining the magnetic and the geographic north poles, the declination is 180° ; the N pole of the compass points towards the magnetic pole and therefore away from the geographic pole. A similar state of affairs exists between the magnetic and geographic south poles. These points can be much better realised by drawing the isogonals upon a globe, and cannot be adequately represented upon a plane diagram.

East of the American agonic line the declination is westerly, that is, the compass needle points west of true north; the isogonals of westerly declination are full lines in Fig. 28. The isogonals of easterly declination are dotted lines and lie west of the American agonic line. It will be seen that the isogonals are far from being regular curves. They reach their greatest irregularity in Eastern Asia, where there is

a district surrounded by a closed agonic line within which the declination is westerly. This is called the Siberian Oval.

Instead of isogonals, the lines which indicate the direction of the magnetic meridian are sometimes plotted. These are called lines of magnetic longitude, or Duperrey's lines, and they are more regular than the isogonals. They also differ from the isogonals in converging to only two points—the magnetic poles.

The lines of equal dip, or isoclinals, are much more regular than the isogonals; they approximate to circles on the sphere, having poles at the magnetic poles. The line of no dip, or the magnetic equator, is shown in Fig. 28. It crosses the geographic equator twice, once in the Atlantic and once in the Pacific Ocean, and lies south of it in the American Hemisphere. The other isoclinals are roughly parallel to the magnetic equator, and therefore correspond to parallels of latitude. The points at which the dip is 90° are the magnetic poles. The North magnetic pole was reached by Sir James Ross in 1831 and found to be in longitude $96^\circ 43'$ W., latitude $73^\circ 31'$ N. The South magnetic pole was reached by Sir Ernest Shackleton's expedition on 16th January, 1909, the magnetic observations being made by Dr. Mawson,¹ who found the dip to be 90° in latitude $72^\circ 25'$ S., longitude $155^\circ 16'$ E. It will thus be seen that the magnetic poles are not quite at opposite ends of a diameter of the earth. The approximate magnetic axis of the earth makes an angle of about 17° with the axis of rotation.

Theory of Terrestrial Magnetism.—As a first approximation, the earth's field may be represented as that due to a short magnet placed

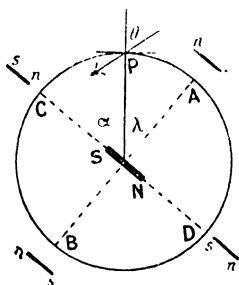

FIG. 29.

at its centre, whose direction is in the line joining the magnetic poles. To represent consistently the magnetic condition of the earth, we must assume that the pole of this fictitious small magnet which lies under the North magnetic pole, has pole of the kind which we have called S, or South seeking, for it evidently attracts the N pole of a suspended magnet and repels the S pole. For such a magnetic condition, the dip needle would be horizontal at such points as A and B (Fig. 29) and vertical at C and D. The latter correspond to the magnetic poles, and the former lie on the magnetic equator. At a point, P, such that the angle subtended by the arc PC at the centre is α , or the "magnetic latitude" λ is $(90^\circ - \alpha)$, we can easily find the dip. For calling m the magnitude moment of NS, and R the radius of the earth,

$$\begin{aligned} \text{Component of moment along radius P} &= m \cos \alpha \\ &= m \sin \lambda, \end{aligned}$$

and the field at P due to this is $\frac{2m \sin \lambda}{R^3}$, and is vertical.

¹ E. Shackleton, *The Heart of the Antarctic*.

Component of moment perpendicular to radius P is

$$m \sin \alpha = m \cos \lambda,$$

and field at P due to it, is $\frac{m \cos \lambda}{R^3}$, and is horizontal.

$$\begin{aligned} \text{If, then, } \theta \text{ is the dip, } \tan \theta &= \frac{2m \sin \lambda}{R^3} \cdot \frac{R^3}{m \cos \lambda} \\ &= 2 \tan \lambda. \end{aligned}$$

As a rough approximation this is useful, but a glance at Fig. 28 shows that no such simple representation of the earth's magnetic condition is possible.

The fact that the magnetic field of the earth is probably due to magnetisation of the earth's material was first pointed out by Dr. Gilbert, of Colchester, who constructed a model, or terella, of magnetite, and showed that a small suspended needle in the neighbourhood of it, dips as a needle does in the earth's field; but he made the mistake of assuming that the magnetic poles were at the ends of the axis of rotation of the earth, and attributed the declination of the compass to irregularly disposed masses of magnetic material in the earth.

The greatest step forward in the theory of terrestrial magnetism was made by Gauss.¹ By mapping out a closed path upon the earth's surface and resolving the horizontal component of the earth's field along it, he obtained the quantity $H \cos \delta$ at each point, and by finding the quantity $\int H \cos \delta \cdot ds$ for short steps ds , taken round the closed path, he found that the result is zero. Hence the magnetic field is not due to an electric current flowing through the curve, that is, there is no vertical current (see p. 231). For this purpose he used a triangle, with Gottingen, Milan, and Paris, as vertices, and found the above to be true within the error of observation. He also calculated the value of the potential at all points upon the earth in terms of the horizontal field at a limited number of places, and so obtained the values of the total intensity and dip all over the earth. The mathematical discussion is beyond the scope of this book, and the student who is interested in the matter is referred to Gauss's original memoir, or, for a short account, to A. Gray's *Treatise on Magnetism and Electricity*, Vol. I.

Amongst other results, Gauss calculated that the north magnetic pole would be in latitude $73^\circ 35' \text{ N.}$, longitude $95^\circ 39' \text{ W.}$, and the south magnetic pole in latitude $72^\circ 35' \text{ S.}$, longitude $152^\circ 30' \text{ E.}$; also the magnetic moment of the earth to be about $0.33R^3$, where R is its radius.

On p. 266 we shall see that the magnetic moment of a uniformly magnetised sphere is $\frac{4}{3}\pi R^3 I$, where I is the intensity of magnetisation,

¹ Gauss, *Allgemeine Theorie des Erdmagnetismus*. Result. d. Magnetischen Vereins, Leipzig, 1839.

and therefore, considering the earth to be a uniformly magnetised sphere, its intensity of magnetisation would appear to be

$$\begin{aligned} \frac{.33}{\frac{4}{3}\pi} &= \frac{1}{4\pi} \text{ approx.} \\ &= 0.08. \end{aligned}$$

The saturation intensity of magnetisation of iron or steel is of the order 1500, and we thus get an idea of the intensity of magnetisation of the earth required to produce its magnetic field. The surface layers of the earth are not capable of so great an intensity of magnetisation as is required by Gauss's theory, so that either the interior of the earth is much more highly magnetic than the layers near the surface, or the magnetic field is due to some other cause, such as circular electric currents flowing from east to west. The theory of the earth's permanent magnetic field is far from complete.

Variation in Magnetic Elements.—The magnetic elements at all points are continually changing, and the change may be resolved into a number of quasi periodic components, together with sudden and irregular changes known as magnetic storms.

(i) *Secular Variation.*—The declination at all points is undergoing a long period change. Records of the declination do not go far enough

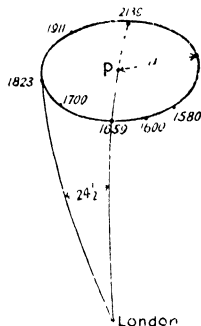

FIG. 30.

back for us to compute with accuracy the periodic time of the secular variation, but it is of the order of magnitude of 960 years. In 1580 the declination at London was $11^{\circ} 15' E.$; in 1600, $5\frac{1}{2}^{\circ} E.$ According to an observation in 1633 it was still $4^{\circ} 5' E.$, and in 1659 it was zero, the compass at London pointing due north. Later observations show a westerly variation, $10\frac{1}{2}^{\circ}$ in 1709, to $24\frac{1}{2}^{\circ}$ in 1820, when it reached its maximum, and has since been diminishing. At the present time (1911) it is $15^{\circ} W.$, and it is probable that in 2139 it will again be zero. It was pointed out by Lord Kelvin that the magnetic system is slowly rotating from east to west, making a revolution in 960 years, so that in 960 years the magnetisation lags behind the earth by one rotation. The magnetic north pole describes a small circle of about 17° radius, and the effect of this rotation upon the declination at any fixed point may be seen from Fig. 30.

(ii) *Annual Variations.*—There is a variation in declination whose periodic time is one year, which occurs simultaneously in opposite directions in the northern and southern hemispheres, the amplitude at London being about $2\frac{1}{4}^{\circ}$. The maximum easterly deviation occurs in August, and the westerly in February.

(iii) *Daily Variation.*—Changes in the earth's field having a period of 24 hours are also observed. In Fig. 31 curve A gives the typical

variation $\delta\theta$ in the declination in this country. This reaches a limiting position about $4'$ east of its mean position just before 8 a.m. and a

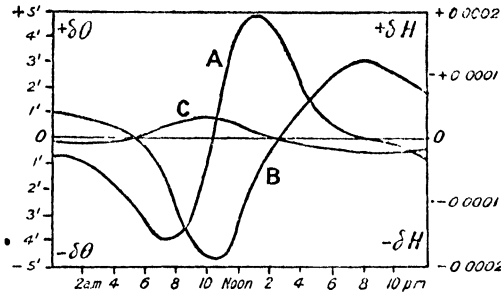

FIG. 31.

maximum $5'$ west at 1.0 p.m. The variation δH horizontal intensity (B) reaches a minimum at about 10 a.m. and a maximum at 7 p.m., while the variation $\delta\theta$ in dip (C) reaches its maximum at 11 a.m. and its minimum at 7 p.m.

The daily variation is not constant, that is, it does not go through the same course on different days. The magnitude of the change is shown in Fig. 32, taken from the results of Dr. Chree,¹ in which the curve O represents the variation in declination on ordinary days, Q that for very quiet days, and D that for days of considerable magnetic disturbance, the values taken being means over an eleven-year period.

Professor Schuster² has investigated the phenomenon of the daily variation, and has come to the conclusion that it is due to causes external to the earth, probably to electric currents in the atmosphere; and the daily magnetic variations cause induced currents in the earth, which reduce the amplitude of the vertical and increase that of the horizontal component. The

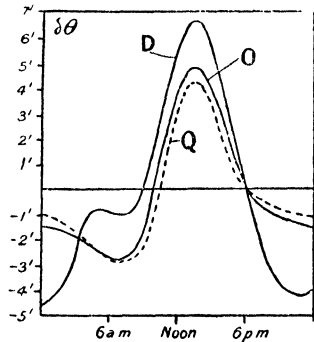

FIG. 32.

earth currents which would produce these magnetic effects are of such a character that they indicate that the earth is not a uniformly conducting sphere; the upper layers conduct better than the lower layers. And further, the observed daily variation is similar in character to that which would be produced by the motion of the atmosphere due to the tidal action of the sun and moon, or periodic variations of the

¹ C. Chree, *Phil. Trans.*, vol 208, A, 1907.

² A. Schuster, *Phil. Trans Roy. Soc.*, vol. 180, Part I. 1889.

barometer, provided that the atmosphere is in such a state that the smallest electromotive force will produce current.

The daily variations in the horizontal component of the earth's field have been represented by v. Bezold in a very convenient form. A vector, representing in magnitude and direction the variation in H from the mean at any instant, is drawn from the point O (Fig. 33). During the day this vector makes a complete revolution, and its extremity describes the curve in the figure, upon which the appropriate times of day may be indicated, and the vector representing any required time may be seen. It is then found that for all points on the earth having the same latitude, the vector diagram of daily variation has the same shape, and by placing the axis AB in the direction of the meridian, the vector at any moment representing the variation, can be added vectorially to that indicating the mean hori-

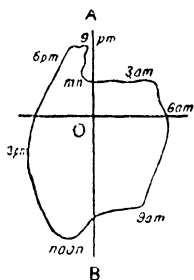

FIG. 33.

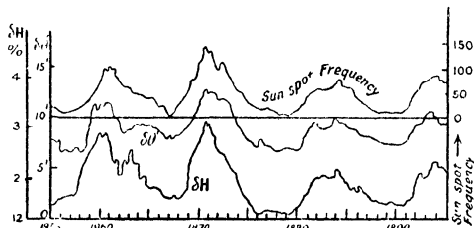

FIG. 34.

zontal component of the earth's field at that point, to obtain the actual horizontal component and the direction in which the compass would set.

The daily variation is less in winter than in summer.

(iv) *Magnetic Storms*.—Simultaneous variations in the magnetic elements over the whole earth are frequently observed, the magnetic needles at the observatories undergoing rapid and sometimes enormous disturbances.

Eleven-Year Period.—On recording the frequency of sunspots and the magnitude of the daily variation in the magnetic elements, a surprising parallelism between the two phenomena becomes apparent (Fig. 34).

It is thus seen that the period of eleven years, during which the frequency of the occurrence of sunspots goes through a cycle, coincides with the period of change in the magnitude of the daily variations. In the diagram $\delta\theta$ is the amplitude of the daily variation in minutes of arc, and δH is the variation in the horizontal intensity expressed as a fraction of the whole amount. The diagram is given by A. Nippoldt,¹ and exhibits very clearly the parallelism in the three quantities.

¹ A. Nippoldt, *Erdmagnetismus, Erdstrom and Polarlicht*.

Cause of Variations.—The origin of the earth's magnetism is still a matter for investigation, but the variations, although not thoroughly understood, have been explained on the assumption that the sun is emitting a radiation similar to the kathode rays, met with in a vacuum tube in which an electric current is passing (Chap. XV.). Such rays consist of minute particles, which, in passing through a gas such as our atmosphere, render it conducting for the electric current. Any potential difference between different localities in the upper layers of the atmosphere would then give rise to electric currents, and such currents having a magnetic field associated with them would, of course, affect the magnetic needle. Such phenomena as the eleven-year recurrence of the maximum daily variation lends colour to such a theory, for the radiation of all kinds from the sun, changes with the nature of its surface. Also the daily variation itself may be due to the same cause; although it must not be forgotten that the changes in temperature due to the alteration in the amount of radiant heat received from the sun may help to cause the observed variations. It may also be noted that Bauer¹ noticed a small wave-like disturbance of the suspended needle, as the moon passed over the sun's disc, in the total eclipse of 1900, which was similar in character to the solar-diurnal variation, but smaller. This change took place at all the observing stations as the moon's shadow passed over them.

Lord Kelvin showed that any attempt to attribute the variations to direct changes in the magnetic condition of the sun must fail, as the amount of energy that must be radiated by the sun, in an ordinary magnetic storm lasting a few hours, would be about equal to the radiation from the sun in the form of heat and light, which takes place normally in an interval of several months. It is much more likely that some radiation, as above mentioned, which does not involve a great loss of energy by the sun, but which changes the electrical conductivity of the upper layers of the atmosphere, supplies the condition for the atmospheric currents, the source of energy of the currents lying in or near the earth itself.

Magnetic storms are not always accompanied by Auroral displays, but the latter are always associated with magnetic disturbances. Also the form of the Aurora Borealis is frequently such as might be explained by streams of kathode ray particles entering the magnetic field of the earth (Chap. XV.); and again, the spectrum of the Aurora is a line spectrum, showing that it is not reflected sunlight; and in it the lines of nitrogen, argon, neon, and xenon have been detected, a fact which points to the conclusion that the light is emitted by the passage of an electric discharge through the atmosphere.

Recording Instruments.—For the purposes of a magnetic survey, portable instruments are necessary, since the magnetic elements at a great many places must be determined. These instruments (pp. 27–32) are not of great precision; and are incapable of measuring small variations

¹ L. A. Bauer, *Terr. Mag. and Atmos. Elect.*, XV. 2, June, 1910.

in the earth's field. Consequently, at certain observatories recording instruments or magnetographs are erected, which give a permanent record of the small variations in the terrestrial magnetic field. The three types of instrument record respectively variations in declination, horizontal intensity, and vertical intensity.

The *declination magnetograph* is an instrument in which a beam of light, reflected from a mirror attached to a suspended magnet, falls upon a sheet of photographically sensitive paper wound upon a drum which rotates at constant speed, the curve traced upon it indicating the variations in the declination. The instrument is thus a combination of the reflecting magnetometer and the chronograph.

In the instrument designed by Watson,¹ nine small permanent magnets are cemented in an aluminium centrepiece, which is suspended by a phosphor-bronze strip, the magnetic system being situated inside a massive block of copper, to cause oscillations to be rapidly damped out (p. 251). The employment of phosphor-bronze for the suspension, renders the reading of the instrument almost independent of temperature, for the elasticity of the phosphor-bronze decreases as the temperature rises, and the magnetic moment of the magnets likewise decreases. Hence the deflecting and the controlling couples rise or fall together, with alteration of temperature.

In the case of the *horizontal variometer* the suspended magnetic system is rotated, either by twisting the suspension or by means of compensating magnets, until its magnetic axis is perpendicular to the magnetic meridian. Eschenhagen,² using a quartz suspension, twisted the torsion head until the magnetic axis was 90° from the meridian. He also used two mirrors upon the suspended system, so that the doubling of the deflection due to reflection occurred twice, with corresponding increase in sensitiveness. If M be the magnetic moment of the system, θ the angle made with the meridian, and a the number of degrees of twist in the suspension,

$$\begin{aligned} & MH \sin \theta = ca. \\ \text{When, } \theta = 90^\circ, & \quad MH = ca, \text{ and, } M\delta H = c\delta a, \\ \therefore \frac{\delta H}{H} = \frac{\delta a}{a}, & \text{ and, } \delta H = \frac{c\delta a}{M}. \end{aligned}$$

Thus, a given change δH will cause a bigger deflection, the smaller c and the greater the value of M . Hence a fine suspension fibre is used, and a is great, amounting to several revolutions, in order to maintain the magnet at right angles to the meridian.

As H varies so does θ , and the movement of the reflected beam of light is recorded photographically. θ never differs much from 90° . The scale of the record is calibrated by causing a deflection by means of a small magnet of known moment, placed at a distance from the instrument (see p. 6).

¹ W. Watson, *Terrestrial Magnetism*, vi. 1901.

² M. Eschenhagen, *Terrestrial Magnetism*, v. 1900.

The *vertical intensity magnetograph* is usually a magnet, mounted as in the case of the dip circle, to rotate about a horizontal axis, the plane of rotation being the magnetic meridian. The end of the needle, which would ordinarily set upwards, is loaded until the needle is horizontal, and the horizontal component of the earth's field does not give rise to a couple tending to rotate the needle. Owing to the direction of the needle being perpendicular to the earth's vertical component, any variation in this, causes corresponding variation in the position of equilibrium of the needle, and its movements are recorded by the beam of light and photographic drum as in the last two cases.

In order to respond to rapid changes in the magnetic field, the magnet must be as light as possible, and when supported upon knife-edges, any mechanical disturbance will cause such a needle to move about in azimuth, with loss in definiteness of the record; also change in temperature produces alteration in the magnetic moment of the magnet, with resulting change in the position of equilibrium.

To get over these difficulties Watson¹ attaches the magnets, which are 8 cms. long and 1 mm. in diameter, to a quartz plate, to which the horizontal suspension fibres are fused.

The arrangement is shown diagrammatically in Fig. 35. E is a slab of fused quartz, the upper face of which is polished and constitutes the mirror. The rods B and C are part of this, and serve both to carry the magnets M, M', and for the attachment of the quartz fibres AB and CD. At A is a spring of fused quartz, to which is fused one end of the fibre AB. The attachments at B, C, and D are all made by fusing the fibres on to the quartz rods, so that the suspension consists entirely of homogeneous fused quartz. At D is a torsion head, the adjustment of which serves to set the magnets horizontal. P is a 45° reflecting prism, to enable the readings to be made by means of a horizontal beam of light.

The small adjustable weight *w* is placed in such a position that the ends M of the needles, which usually point upwards, are now depressed below the level of the axis, and the magnets are brought into a horizontal position by rotating the torsion head D, in a clockwise direction. The earth's vertical magnetic field tends to raise MM and depress M'M', and any variation of the field is observed by the corresponding rotation of the magnets and the attached mirror E.

By the construction chosen, the apparatus is practically free from error due to change of temperature, for if this rises, the magnetic moment of the magnets decreases and the ends MM would be depressed. But

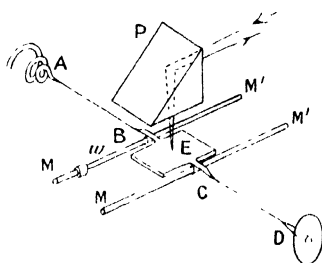

FIG. 35.

¹ W. Watson, *Proc. Phys. Soc. Lond.*, XIX. II. 1904.

the rigidity of the quartz fibres increases with rise of temperature, and so the couple exerted by them increases, causing the ends MM to be raised. The two effects are therefore opposite, and by adjusting the position of the small weight w , and the torsion in the fibres, the apparatus may be compensated for temperature change.

The Kelvin Compass.—Several improvements in the old form of ship's compass were introduced by Lord Kelvin; the old ones being generally too large, and slow in movement. The Kelvin pattern is now universally employed. It has a ten-inch card, consisting of a thin sheet of aluminium or paper, on which a scale is pasted, or drawn, and varnished. The middle portion is removed for the sake of lightness.

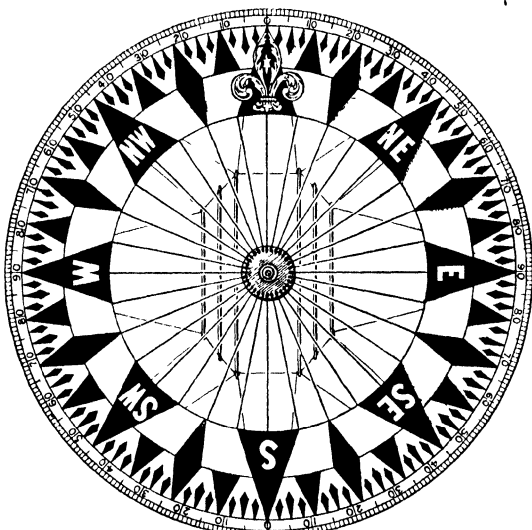

FIG. 36.

In the middle is the system of magnets (six or eight) slung on to radial threads, giving a system of high magnetic moment and very small weight. Any oscillations in the magnet are therefore of small amplitude and are damped out much more rapidly than with the older and heavier magnets of proportionately smaller magnetic moment. In many of the modern compasses the card is immersed in methylated spirit, which takes most of the weight off the needle-point, and also serves to damp vibrations.

Method of Applying the Variation of the Compass.—In navigating a ship the officer must, after determining his true course from a chart, apply the magnetic variation, in order to obtain the magnetic course, or course according to the compass, along which he has to sail. The

method of applying the variation (declination) may be seen from Fig. 37. If the variation is E, the ship's course when west of north is apparently increased, and the variation is to be added to the true course to obtain the magnetic course. Thus if the true course is θ° west of north and the variation is α° east (Fig. 37), the magnetic course is $(\theta + \alpha)$, W of N. If the variation were α° west of north the magnetic course would have been $(\theta - \alpha)$, W of N. By a similar process the true course may be found from the magnetic course when the variation is known.

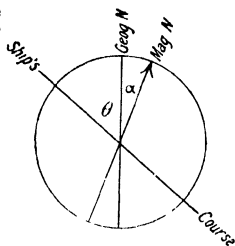

FIG. 37.

Deviation due to Ship's Iron.—In addition to the declination or variation, which is obtained from a chart similar to that on p. 35, disturbances caused by the magnetisation of the iron of the ship itself must be taken into account. In ships constructed largely of iron and steel, these deviations from the chart direction of the compass are usually considerable, and unfortunately they are generally variable. This necessitates their frequent determination for every ship; the process is called "swinging the ship."

The magnetic direction of a given distant object being known, the ship is allowed to swing round to as many points of the compass as possible, the magnetic bearing of the distant object by the standard compass on board, being taken and recorded. The difference between this and the known magnetic bearing of the distant object, is the deviation produced by the ship's iron. The true magnetic bearing is frequently determined by sending a compass ashore and observing the ship's bearing according to the shore compass. The magnetic bearing of the shore compass is then known, since it is the complement of the bearing of the ship according to the shore compass. The deviation for each magnetic bearing may be applied as a correction to the variation, in a manner similar to that in which the variation was applied to the geographical bearing. There are many ways of recording the deviations graphically, but Fig. 38 shows the method that is probably the simplest. The points of the compass being plotted along a vertical line, the deviations at each position are measured horizontally, to the left when the deviation is W, that is, when the pole of the compass (N or S) is deflected to the left hand, as seen from the centre of the compass, and to the right when the deviation is E.

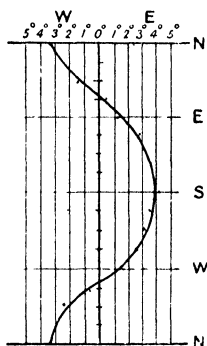

FIG. 38.

Such curves must be obtained from time to time, and in different latitudes, since the magnetisation of the ship varies; the chief cause in

the variation being the variation from place to place of the earth's magnetic field and the consequent change in the magnetisation of the ship.

Napier's Curve.—A second method due to J. R. Napier is of great convenience, since it enables the curve to be plotted from the observations without the necessity of constructing a table, and the corrected compass courses may be directly observed from the curve. The points of the compass are plotted along the vertical line, with their corresponding values in degrees. The points of the compass are marked upon the right-hand side of the line NN, which corresponds to the margin of the compass card.

Lines inclined at 60° to the vertical are drawn through equidistant points on the vertical line, one set being dotted and the other plain (Fig. 39). As the deviation for each compass course is observed, a distance AB, equal in length to the deviation, on the same scale as the vertical one, is measured parallel to the dotted lines, to the left if the deviation is W and to the right if E. B is then a point on the curve. When a sufficient number of points has been determined a flowing curve is drawn through them.

In order to make use of the diagram, let us suppose that we require to know the magnetic course that corresponds to the compass course indicated by the point A. From A pass along a dotted line, or parallel to the nearest one, until the curve is reached, and then pass along a plain line back to the vertical, meeting it at C. Then C indicates the magnetic course. For, since all the angles in the figure are equal to 60° , ABC is an equilateral triangle, and $AB = AC$. Now, AB is the deviation, therefore AC is also equal to the deviation, that is, the difference between the magnetic and the compass courses, and since it is W, it must be subtracted from the compass course to get the magnetic course (see p. 45). Hence C corresponds to the magnetic course.

Similarly, if e be a given magnetic course and we require the compass course, pass from e to the curve at f , by a path parallel to the plain lines, and thence to g by a path parallel to the dotted lines. g is then the compass course.

Causes of Deviation.—In ships built chiefly of iron and steel there are many sources of disturbance of the compass, but for convenience we may divide them into two classes—those due to permanent magnetism, which are generally acquired at the time of building the ship, and those due to transient magnetism, which vary with the magnetic field

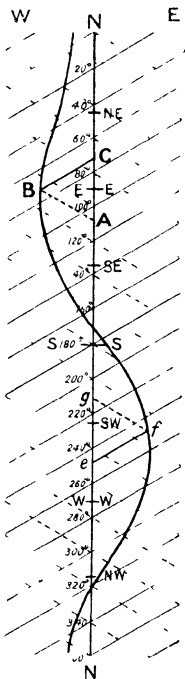

FIG. 39.

11. SEMICIRCULAR AND QUADRANTAL DEVIATION 47

in which the ship happens to be situated at the time of making the observation.

The first of these depends for its character upon the position of the ship during building, the line in the ship which was in the magnetic meridian being approximately the magnetic axis of the ship. In the northern hemisphere this would mean a N magnetic pole in the part directed northwards, and whenever this part again faces N or S, the deviation due to this cause is zero. In all other positions a deviation is produced. If NS be the permanent magnetic axis of the ship, and h the strength of the magnetic field at the compass due to the ship's magnetisation, the couple exerted on the compass is $h \sin \theta$, where θ is the angle between the magnetic axis and the compass needle. The deviation is westerly when the magnetic N end of the ship is E of the magnetic meridian (Fig. 40), and easterly when the N end is W. For this reason it is called a *semicircular deviation*, since it remains of the same sign for a change in 180° of the ship's direction.

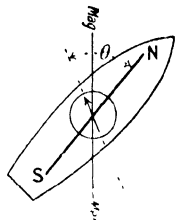

FIG. 40.

Another source of semicircular deviation is the soft iron in a vertical position. This is magnetised by the vertical component of the earth's field, to an extent roughly proportional to its intensity. The direction of magnetisation is therefore opposite in the northern and southern hemispheres. The effect on the compass depends upon the distribution of the iron, and the field due to it is proportional to the vertical component V of the earth's field. Since the effect in producing deviation varies inversely as the horizontal field H which controls the compass, the deviation is proportional to $\frac{V}{H}$, that is, to the tangent of the dip.

As the ship changes in azimuth, the deviation due to vertical soft iron only changes in sign as the mass of iron concerned passes the meridian from W to E, or E to W, so that the deviation in this case is semicircular. The total semicircular deviation is the resultant of this and the above.

Masses of soft iron situated with their direction horizontal are magnetised by the earth's horizontal field, and their effect upon the compass depends largely upon their position. Thus in Fig. 41 (i),

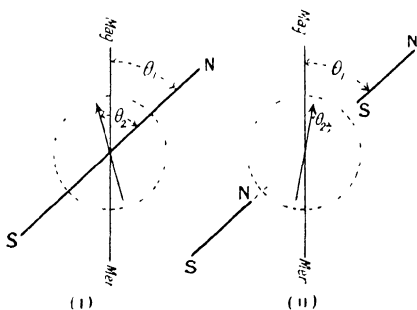

FIG. 41.

the result is to make the deviation W. and in (ii) to make it E. If δ , be

the angle between the magnetic meridian and the axis of a bar of soft iron, the induced magnetism is proportional to $\cos \theta_1$. The deviating effect upon the needle is proportional to $\sin \theta_2$, where θ_2 is the angle between the axis and that of the needle. Hence the deviation due to this cause varies as $\cos \theta_1 \sin \theta_2$, or as $\sin 2\theta$, where the small difference between θ_1 and θ_2 is ignored. $\sin 2\theta$ changes sign four times for one rotation in azimuth of the vessel, and is constant in sign only for one quadrant, the deviation due to horizontal soft iron changing in sign from quadrant to quadrant. For this reason this is called *quadrantal deviation*.

A constant error in the deviation may occur through improper setting of the magnets of the compass with respect to the card, or through the magnet being placed out of the line of symmetry of the ship.

Equation for Deviation.—The semicircular deviation, being proportional to the sine of the angle between the magnetic meridian and some line in the ship, may be written $k \sin (\zeta + b)$, where ζ is the angle between the median line of the ship and the magnetic axis of the compass, that is, ζ is the compass course, and b some constant angle depending upon the direction of the permanent magnetisation of the ship. Now, $k \sin (\zeta + b) = k \sin \zeta \cos b + k \cos \zeta \sin b$, and taking $k \cos b$ and $k \sin b$ as two constants B and C , the semicircular deviation may be written in the form $B \sin \zeta + C \cos \zeta$.

Similarly, the quadrantal deviation may be written $D \sin 2\zeta + E \cos 2\zeta$, and the whole deviation δ has then the form—

$$\delta = A + B \sin \zeta + C \cos \zeta + D \sin 2\zeta + E \cos 2\zeta.$$

δ and ζ are both considered to be positive when directed E of N. $\delta + \zeta$ is the magnetic course of the ship. In practice A and E are found to be very small, and the approximate equation for the deviation may then be written—

$$\delta = B \sin \zeta + C \cos \zeta + D \sin 2\zeta.$$

When $\zeta = 0$, then $\delta_N = C$, and we therefore see that C is the deviation when the ship's direction is magnetic N and S. Again, if $\zeta = 90^\circ$, $\delta_E = B$, and consequently B is the deviation when the ship's direction is at right angles to the magnetic meridian.

When, $\zeta = +45^\circ$, *i.e.* when the ship's head is NE,

$$\delta_{NE} = \frac{B}{\sqrt{2}} + \frac{C}{\sqrt{2}} + D$$

and when, $\zeta = -135^\circ$, *i.e.* when the ship's head is SW

$$\delta_{SW} = -\frac{B}{\sqrt{2}} - \frac{C}{\sqrt{2}} + D$$

$$\therefore D = \frac{\delta_{NE} + \delta_{SW}}{2}$$

Thus D is the mean of the deviations when the ship's head is in the positions NE and SW.

Having determined the constants B, C, and D, three curves may be constructed, two of which are sine curves and the third a curve of $\sin 2\zeta$, and on adding the values at each course, a curve giving the deviation for all courses may be found. When greater accuracy is required, the five constant coefficients may be determined from readings made on all the principal points.

Heeling Error.—When the median plane of the ship is vertical, the resultant magnetic field due to the iron is not generally horizontal; its vertical component, however, will have no effect upon the direction of the compass. Should the median plane become inclined, this component will no longer be at right angles to the plane of movement of the needle, and it will consequently have a directive influence, and will produce a deviation known as *heeling error*. Whether this deviation is towards the higher or lower side of the ship, depends upon the distribution of iron with respect to the compass, and in some cases is in opposite directions in the northern and southern hemispheres.

The heeling error is greatest when the ship's direction is N and S, since the vertical component of the ship's magnetic field will become inclined as the ship rolls, and will, in its new position, have a horizontal component which is E or W. On the other hand, when the ship is E and W, this horizontal component will be N or S, and will not directly produce deviation. It may, however, by altering the control upon the needle, cause a change in the deviation produced by other causes.

Compensation of Deviation.—There is no method of reducing to zero the deviation produced by the ship's magnetism, but the various errors may be compensated to a considerable extent by placing magnets, or soft iron, in suitable positions, the compensating apparatus being in each case of such a nature that if acting alone it would produce an error of the same nature as that which it is required to correct, but with sign reversed.

(i) *Quadrantal Deviation.*—Various devices have been used at different times for correcting the quadrantal deviation, such as masses of cast iron, or boxes of chain. The usual method employed at the present time, is to attach two hollow soft iron spheres to the binnacle, one on either side of the compass and on a level with it. The deviation produced by such spheres is evidently quadrantal, and since the uncorrected quadrantal deviation produced by the ship is found in practice to be always positive, *i.e.* to the E of N, it will be seen from Fig. 42 that the deviation due to the spheres will be opposite in direction to that due to the ship, and may be used to compensate it. The spheres are adjustable in distance from the compass needle, and they may be placed by trial. As a rule, however, the coefficient D (p. 48) is determined for the uncompensated compass, and the position of the spheres of any given size obtained from tables published by the Admiralty. Thus with a

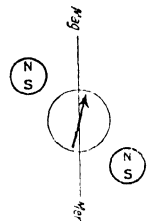

FIG. 42.

10 ins. Kelvin compass and spheres of 5 ins. diameter, the value of D corrected by spheres situated with their centres 9 ins. from the needle is $2^{\circ} 2'$, and with their centres 12 ins. from the needle $0^{\circ} 56'$.

(ii) *Semicircular Deviation*.—On p. 47 we saw that the semicircular deviation is due to two causes, namely, permanent magnetisation, and magnetisation due to the vertical component of the earth's field. Hence, to compensate this deviation, two different devices corresponding to the two sources of the error are necessary. To compensate for the permanent magnetisation, small permanent magnets are attached to the compass box. Having first corrected for the quadrantal deviation, the ship's head is placed magnetic N and small permanent magnets are fixed in transverse holes in the binnacle, the number being increased until the deviation is reduced to zero. The ship's head is then placed E or W, and a second set of small permanent magnets placed at right angles to the first set, to reduce the deviation again to zero.

The correction for the magnetisation due to the vertical component of the earth's field is performed by placing a soft iron bar vertically in front of or behind the binnacle. Such an arrangement is called a Flinders' bar, after its inventor, Captain Flinders. The suitable position of the Flinders' bar may be calculated from the known value of the coefficients in the deviation equation, but this is outside the scope of this work.

(iii) *Heeling Error*.—This may be corrected by a magnet placed vertically with its pole underneath, and at some distance from, the compass. In this way a vertical field equal and opposite to that due to the magnetisation of the ship may be produced.

The above brief sketch of the deviations produced by the magnetisation of a ship, and the methods of their correction, is here introduced as an example in the composition and resolution of magnetic fields. For a full account of the subject the student may consult the *Admiralty Manual for the Deviations of the Compass*, by F. J. Evans and Archibald Smith.

CHAPTER III

THE ELECTRIC CURRENT

UNDER certain circumstances an ordinary metallic wire may exhibit distinctive phenomena, the most striking being, the existence of a magnetic field in the space surrounding it, and the production of heat in it. We say, then, that an electric current is flowing in it. The electric current is always accompanied by these two effects, and their presence may be taken to indicate its existence. Our reason for speaking of this phenomenon as a current, which implies a flow of something along the wire, rather than as a statical condition, will appear later.

Magnetic Field accompanying a Current.—An infinitely long straight wire, carrying an electric current, is surrounded by circular lines of magnetic force, the centres of the circles lying upon the axis of the wire, their planes being perpendicular to it. In the case of any straight piece of wire which is fairly long, the magnetic lines may easily be mapped out, either by the method of iron filings, or with a small compass needle, and will be found to be approximately circular (Fig. 43). In the case of a circle of wire carrying a current (Fig. 44),

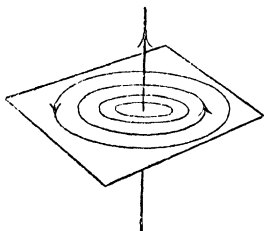

FIG. 43.

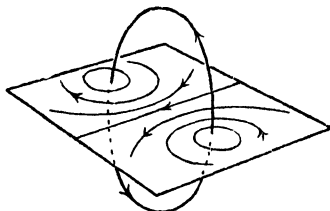

FIG. 44.

the magnetic lines of force are not so simple in shape as in the case of a straight wire, but they may be found in a similar manner, and it will be noticed that for a small region near the centre of the circle, the field is nearly uniform, that is, the lines are nearly parallel. The fundamental experiments exhibiting the presence of a magnetic field when an electric current is flowing are due to Oersted (1820), the existence of the current having been recognized by certain other effects for the previous twenty years.

Ampère's Theorem.—In his celebrated memoir¹ of 1823, Ampère stated that "Every linear conductor carrying a current is equivalent to a simple magnetic shell, the bounding edge of which coincides with the conductor, and the moment of which per unit of area, that is, the strength of the shell, is proportional to the strength of the current." By a magnetic shell is meant an infinitely thin sheet of material, magnetised in a direction at right angles to the surface of the sheet, so that one side of the sheet is a N, and the other a S, polar surface. The form of the magnetic field due to a current may therefore

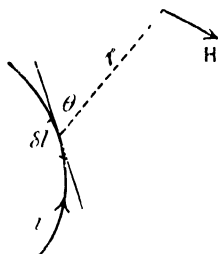

FIG. 45.

be calculated by means of purely magnetic considerations, on replacing the current circuit by its equivalent magnetic shell; but the same result may also be obtained for a complete circuit by treating each small element of it as a straight current of length δl , and applying the relation $H \propto \frac{i \delta l \sin \theta}{r^2}$, where H is the resulting strength of magnetic field, i the current, r the distance from the element of the circuit to the point at which H is to be found, and θ the angle between the direction of the current and the line joining the element to the point. The direction of the field is at right angles to the plane containing the element and the line joining it to the point, and is indicated in Fig. 45.

This law was proved by Biot and Savart to hold in the case of a long straight wire carrying current. The magnetic fields, as determined by this method and by that of the equivalent magnet shell, are identical. It may be noted that the method of the magnetic shell is the more satisfactory, as, however difficult the problem may be, it is always possible to find a magnetic shell, or system of shells, that will be equivalent to the current; while the method of the element of a circuit is a purely fictitious one, since an element of a circuit cannot exist alone, the current always flowing in complete circuits. Nevertheless, the latter method is, in many cases, the more easy to apply, and it has also been given a certain reality by Heaviside's consideration of the *rational current element*. For if the current circuit be looked upon as a series of small elements placed end to end, immersed in a conducting medium, each element, considered apart from the others, has current flowing in it, the current leaving by one end, spreading out into the surrounding medium, and eventually returning to the other end in exactly the same way as the magnetic lines of force spread out from the N pole of a bar magnet and return to the S pole. If we place a chain of similar bar magnets end to end with a N pole always in contact with the S pole of the next magnet,

¹ *Théorie des phénomènes électro-dynamique, Mémoires de l'Institut, IV., 1823.*

the external effects of the poles in contact are everywhere equal and opposite, and the only external effects are those due to the last N pole at one end of the chain of magnets, and the S pole at the other end. If then the chain be completed by bringing the extreme N and S poles into contact so that we have a complete circuit, all external magnetic effects will vanish. In an exactly similar manner, if one end of each of our current elements be a source of current spreading outwards, the other end being a sink for the current converging to it, when these are placed in contact, the flow at external points will consist of two equal and opposite components, and will therefore be zero. If we make our chain of elements complete, the external current will everywhere be zero, the current merely flowing round the closed circuit. Heaviside¹ suggested this reasoning in order to get over the difficulty of realising the possibility of short current elements existing alone.

If, then, the magnetic field due to each element of a circuit be found by the relation $H \propto \frac{i\delta l \sin \theta}{r^2}$ and the resultant at any point be found for the whole current circuit, we need not trouble about the field due to the imaginary currents spreading out from each element, as these will cancel out when the whole circuit is considered.

Unit of Current.—The magnetic field due to a current being the most constant and the simplest of the accompanying phenomena, it is chosen for the purpose of measuring the current. The unit strength of magnetic field being established (p. 3), we may now define our unit of electrical current in terms of it.

Thus, *the unit current is one that is equivalent to a magnetic shell of unit strength*; or, by means of the relation on p. 52, we may define the unit of current as that which will enable us to replace the sign of variation by one of equality, so that

$$H = \frac{i\delta l \sin \theta}{r^2}.$$

In this equation δl is a very small quantity, and hence if r is to be constant, while δl is increased to finite size, the circuit must evidently be in the form of a circle. Thus the field at the centre of the circle is $\frac{i l}{r^2}$ and is at right angles to its plane, l being the total length of arc in which the current flows. If then i , l , and r are all unity, the field is of unit strength, and we have the ordinary definition of unit current, *as that current which flowing in an arc of a circle of unit length, the radius being unity, produces unit magnetic field at the centre.* If the circle consist of n complete turns $l = 2\pi nr$, and it follows that

$$H = \frac{2\pi ni}{r}.$$

¹ O. Heaviside, *Electro-magnetic Theory*, Vol. I.

Tangent Galvanometer.—The last equation is employed in a form of instrument for measuring an electric current in terms of a magnetic field and a deflection, and from the form of the relation between the current and the deflection, the name “tangent galvanometer” is given to the instrument. It is essentially a magnetometer in which the magnetic field, F , is due to the current flowing in a vertical circular coil, whose plane is in the magnetic meridian. The two fields in which the needle is situated are therefore F , due to the coil, and H , the horizontal component of the earth’s field (Fig. 46); and the needle is in equilibrium when its magnetic axis makes an angle $\theta = \tan^{-1} \frac{F}{H}$ with the magnetic meridian.

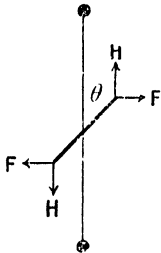

FIG 46.

Then since—

$$F = \frac{2\pi ni}{r}$$

$$\frac{2\pi ni}{rH} = \tan \theta, \text{ or, } i = \frac{rH}{2\pi n} \tan \theta.$$

A common type of the apparatus is shown in Fig. 47, two coils being provided, one of 2 turns of thick wire for use with large currents, and one of about 20 turns for use with smaller currents. The deflection is observed by means of a

fine pointer which moves over a horizontal circular scale, parallax being avoided by placing the eye vertically over the needle in taking a reading, the eye being moved until the image of the needle in a plane mirror lying underneath it appears to coincide with the needle itself. In principle the tangent galvanometer resembles the magnetometer described on p. 7, the linear scale and bar magnet being replaced by the circular coil carrying the current.

The same precautions with respect to reading both ends of the pointer, and reversing the deflection so that the

reading is made on the other side of zero, are made, as in the case of the magnetometer, and further the pointer must be adjusted to be at right angles to the needle. Owing to the fact that the magnetic field

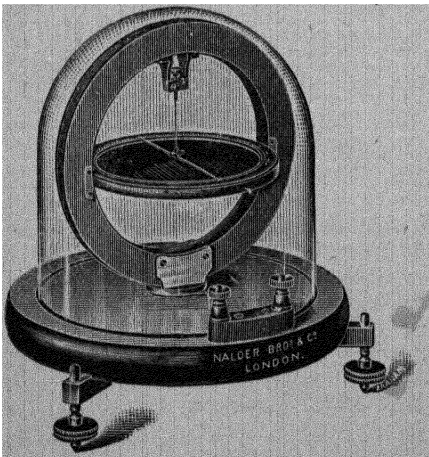

FIG 47.

at the centre of the coil is sensibly uniform for only a small area, the needle must be as small as possible; if too large it is not in a uniform field, and the relation given above will not hold good.

In making observations, the deflections should be neither too great nor too small. If too small, any error in reading is a very large proportion of the whole deflection, and if too great, the tangent of the deflection increases so rapidly that a small change in deflection means a very large actual change in the value of the current. To find the position on the scale for readings of greatest accuracy, consider $\delta\theta$ to be a small increment in the deflection corresponding to the increment δi in the current. $\frac{\delta i}{i}$ is the relative change in the current, and $\frac{\delta i}{100i}$ the percentage change in the current corresponding to $\delta\theta$, and for greatest accuracy $\frac{\delta i}{i}$ should therefore be as small as possible.

Since the current is proportional to the tangent of the deflection, $i = K \tan \theta$.

and, $\frac{\delta i}{\delta\theta} = K \sec^2 \theta$, when δi and $\delta\theta$ are infinitesimal;

$$\therefore \frac{\delta i}{i} = \frac{\sec^2 \theta}{\tan \theta} \cdot \delta\theta = \frac{2}{\sin 2\theta} \delta\theta.$$

Hence for $\frac{\delta i}{i}$ to be as small as possible for a given value of $\delta\theta$, $\frac{2}{\sin 2\theta}$ must be as small as possible; *i.e.* $\sin 2\theta$ must be as great as possible. This occurs when $2\theta = 90^\circ$, or $\theta = 45^\circ$. Hence it is desirable to make the deflection as near to 45° as possible, whenever accuracy in determining the current is required. The curve, Fig. 48, shows the relative accuracy in determining the current when the deflection varies from 0° to 90° , taking the accuracy at 45° as 100. It will be seen that for the accuracy not to fall to 50 per cent. of the maximum, the deflection must lie between 15° and 75° .

A more refined instrument is shown in Fig. 49. In this case there are two coils, the distance between them being equal to the radius of either coil, the object being to obtain the most uniform field in which to suspend the needle.

In order to find the strength of magnetic field at a point on the axis of a circular coil at a distance x from the centre, consider the field due to an element δl of the circle. The field at A (Fig. 50) due to this element is $\frac{i \cdot \delta l}{r^2}$, where i is the current in the coil, and is in the direction AB, at right angles to the plane containing r and δl . This may be resolved into two components, AC along the axis, and AD at right angles to it. Every element of the circular coil will produce a component at right angles to the axis and in each case it is parallel to

the radius of the circle drawn to the element. Hence, taking the whole circle, these components of the field corresponding to AD will

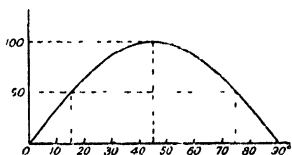

FIG. 48.

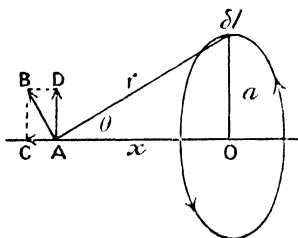

FIG. 50

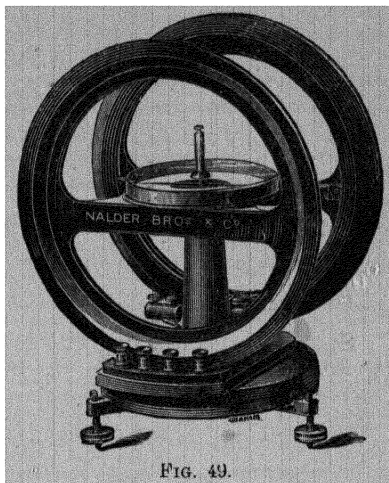

FIG. 49.

give a resultant zero. The components corresponding to AC, which are along the axis, will on the contrary be added together.

Component AC due to element δl

$$= \frac{i \cdot \delta l}{r^2} \cdot \frac{AC}{AB} = \frac{i \cdot \delta l \cdot a}{r^2} \cdot \frac{1}{r} = \frac{ia\delta l}{r^3}.$$

For the whole circle, δl must be replaced by $2\pi a$.

$$\therefore \text{Field} = \frac{2\pi a^2 i}{r^3},$$

and if the coil consist of n turns sufficiently close together to take a mean radius without introducing a sensible error,

$$\text{Field} = \frac{2\pi n a^2 i}{r^3}$$

Again, $r^2 = x^2 + a^2$;

$$\therefore \text{Field} = \frac{2\pi n a^2 i}{(x^2 + a^2)^{\frac{3}{2}}}$$

The strength of field at a point upon the axis is therefore greatest at the centre of the circle, for here $x = 0$ and the expression becomes $\frac{2\pi n i}{a}$. It decreases as we pass away from the centre, becoming zero

at infinity, but its rate of change as we pass away from the centre is not constant. The rate of change from point to point along the axis is the differential coefficient of the above expression with respect to x , that is $\frac{d}{dx} \left[\frac{2\pi na^2 i}{(x^2 + a^2)^{\frac{3}{2}}} \right]$, and it is of importance to find whether there is any point upon the axis, at which this *rate of change* becomes constant. Calling it y we see that if it is constant, then

$$\frac{dy}{dx} = 0, \text{ or, } \frac{d^2}{dx^2} \left[\frac{2\pi na^2 i}{(x^2 + a^2)^{\frac{3}{2}}} \right] = 0.$$

Now, $2\pi na^2 i$ is constant, so that in dealing with rates of change it may be omitted; also remembering that

$\frac{1}{(x^2 + a^2)^{\frac{3}{2}}} = (x^2 + a^2)^{-\frac{3}{2}}$, we have—

$$\frac{d}{dx} (x^2 + a^2)^{-\frac{3}{2}} = -3x(x^2 + a^2)^{-\frac{5}{2}}$$

$$\frac{d^2}{dx^2} (x^2 + a^2)^{-\frac{3}{2}} = -3 \{ (x^2 + a^2)^{-\frac{5}{2}} - 5x^2(x^2 + a^2)^{-\frac{7}{2}} \}$$

Putting this equal to zero and dividing throughout by $-3(x^2 + a^2)^{-\frac{5}{2}}$, we have—

$$5x^2(x^2 + a^2)^{-1} = 1,$$

$$\therefore 5x^2 = x^2 + a^2, 4x^2 = a^2, \text{ or } x = \frac{a}{2}.$$

Thus, at the point on the axis whose distance from the plane of the circle is $\frac{a}{2}$, the rate of change of the field as we pass along the axis becomes constant.

This fact is made use of in the Helmholtz pattern of galvanometer (Fig. 49); the two coils are placed coaxially and at a distance apart equal to the radius of either, the rate of change of field being most uniform at a point midway between them, which point is at a distance $\frac{a}{2}$ from each coil. Any diminution in field due to one coil as we pass away from this point is compensated for by the equal increase in the field due to the other coil, the rate of change being here constant and occurring in opposite directions for the two coils. Substituting the value $\frac{a}{2}$ for x in the expression for the field on the axis of a coil, and remembering that there are two coils, we have

$$F = \frac{4\pi na^2 i}{\left(\frac{5a^2}{4}\right)^{\frac{3}{2}}} = \frac{32}{\sqrt{5}} \frac{\pi ni}{a}.$$

And the expression for the deflection is

$$\frac{32}{\sqrt{5}} \cdot \frac{\pi ni}{a\pi} = \tan \theta,$$

$$\text{or, } i = \frac{\sqrt{125}a\pi}{32\pi n} \tan \theta.$$

The above reasoning may be illustrated by plotting the values of the field strength due to a coil at different distances from the centre. The curve PQR (Fig. 51) is obtained, which will be seen to be straight at the point Q at a distance $\frac{a}{2}$ from the coil, since the curve changes here from being convex upwards to being concave upwards. The rate of change of field at this point is constant, that is, its variation is zero. The curve SQT is plotted for the second coil, and the curve M is

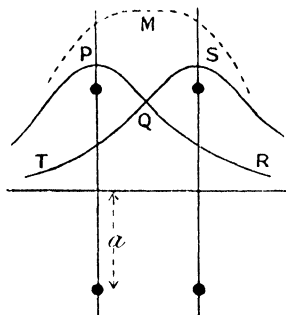

FIG. 51.

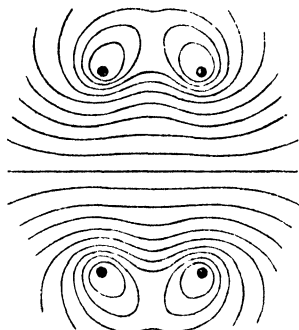

FIG. 52.

obtained by adding the ordinates of the other two, and represents the resultant field due to both coils. It is easily seen that for some distance on either side of the point midway between the coils the field is fairly constant, the reason being that the two curves are straight at Q, so that the falling off in either direction of one of the fields is balanced by the equal increase of the other field.

In Fig. 52, the lines of force for the double coil are drawn, and it will be seen that in the middle of the field there is a region of considerable extent where the magnetic field is approximately uniform.

Electromotive Force and Potential Difference.—Whenever a current flows in a conductor, heat is developed in it, the amount of heat developed being proportional to the time for which the current flows; moreover, it is always found necessary to apply some external agency to maintain a steady current. This implies that work is being expended in order to maintain the current, the energy being drawn

from the outside source. The rate of expenditure of energy required to maintain the current is measurable in terms of the rate of production of heat, when there is no change taking place in the conductor. From analogy with the flow of water in a closed circuit, in which case the flow is maintained by some mechanical agency such as a pump at some point or points, we consider that the electric current is maintained by an electromotive force. Just as we took the magnetic field in the neighbourhood of a current as a measure of the current itself, so we may take the rate at which energy is expended to maintain a current to measure the necessary electromotive force. Then for a given current, the electromotive force (or more shortly the E.M.F.) required to maintain it, is proportional to the rate at which energy is expended, and by choosing suitable units we arrive at our unit of E.M.F. Thus, *when the current is unity and the rate of working is one erg per second, the E.M.F. is unity*, and in terms of these units

$$\text{Rate of working} = (\text{current} \times \text{E.M.F.}) \text{ ergs per second.}$$

Thus, if an E.M.F. e maintain a current i , for t seconds,

$$\text{Work done} = eit \text{ ergs.}$$

It must be remembered that a given conductor is usually only part of the circuit, and somewhere in the circuit is the source of the energy required to maintain the current. This source may be an electric battery, in which case the ultimate source of the energy may be some chemical reaction occurring in the battery; or it may be a dynamo-electric machine, in which case the energy is derived from some kind of heat engine, or it may be one of a number of other sources; but in any case the rate of working to maintain unit current in the circuit is called the electromotive force in the circuit. The resulting heat may be liberated in various parts of the circuit, and this will take place according to laws which we must now examine.

An electromotive force always acts in one direction in the circuit, and if there be a number of electromotive forces in the same circuit, the excess of those acting in one direction over those acting in the other direction is the resultant or effective electromotive force in the circuit. Thus an electromotive force is a directed quantity and in this respect is analogous to a mechanical force. In many mechanical processes the energy supplied by the driving force is eventually dissipated as heat, and the rate at which the heat is developed at various points depends upon the frictional resistance to motion at these points. Similarly, in the case of an electrical circuit the energy supplied by the source of E.M.F. appears as heat in the circuit, but the rate of production of heat at any point, for any given current, varies according to the nature of the conductor at that point.

For a given conductor, the work converted into heat in it in one second when unit current flows, is called the *potential difference* between its ends. Thus, potential difference is measured in the same

units as electromotive force, but they have this difference, that an electromotive force has always the same direction in the circuit, whereas the potential difference has a direction depending on that of the current. If the current flow in a circuit in the direction in which the electromotive force tends to produce current, the source of electromotive force transfers energy to the circuit and the energy of the source decreases, but if the direction of the current be reversed so that the electromotive force opposes its flow, the energy of the source of electromotive force increases at the expense of the energy of the source of greater electromotive force which is maintaining the current in the circuit. On the other hand, a potential difference always corresponds to the dissipation of energy in form of heat in the circuit, whichever way the current flows. Thus, if electromotive force corresponds to a motive mechanical force, potential difference corresponds to a frictional force, which depends for its direction upon the direction of motion, and is a measure of the heat produced per second between two points, for a given continuous motion of matter between one point and the other.

If the potential difference between two points in a conductor in which there is no electromotive force, is zero, there is no dissipation of energy in the form of heat in the conductor, and, except in the limiting case when the conductor does not offer any resistance, this means that there is no current. In the case of water flowing in a tube in which there is no motive force due to a pump or gravity, we say that the flow is from points of high pressure to those of low pressure, and in the electrical case we also say that the point from which the current flows is at a higher potential than that towards which it flows.

Ohm's Law.—In the chapter on Electrostatics (V) we shall see that potential difference may be measured quite independently of any current flowing, and if for any conductor the potential difference be measured by this independent means, and the current also be measured, say, by the tangent galvanometer, it will be found that for the case of an ordinary metallic conductor there is a simple relation between potential difference and current, the current is proportional to the potential difference. This relation was first clearly stated by G. S. Ohm¹ and is known as Ohm's law. Although Ohm had not the means of establishing the law with any great certainty, later experimenters verified it to a high degree of accuracy.

Resistance.—Ohm's law may be expressed in the form,

$$\frac{\text{potential difference}}{\text{current}} = \text{constant},$$

for any conductor under constant physical conditions. The name resistance has been given to this constant, and the name conductance to the inverse of it.

¹ G. S. Ohm, *Die galvanische Kette mathematisch gearbeitet*. Berlin, 1827.

Thus, $\frac{\text{p.d.}}{i} = \text{resistance}$, $\frac{i}{\text{p.d.}} = \text{conductance}$.

The unit of resistance follows at once from the units of potential difference and of current, and is the resistance of a conductor in which unit potential difference corresponds to unit current, or the potential difference between the ends of the conductor is unity when unit current flows in it.

Thus, $\frac{\text{p.d.}}{i} = r$, or, $\text{p.d.} = ir$.

And, rate of working = $\text{p.d.} \times i = i^2 r = \frac{(\text{p.d.})^2}{r}$ ergs per second.

Practical Units.—Although the centimetre, gramme, and second are of convenient size for the measurement of length, mass, and time, the derived units of electromotive force, current, and resistance, resulting from them, and called the absolute C.G.S. units, are not of convenient size for ordinary electrical purposes. Hence a new unit of current is chosen which shall be simply related to the old unit, but of more useful size; it is called the *ampere*, being named after the celebrated experimenter Ampère, and is one-tenth of the size of the absolute unit. Thus the expression for the field at the centre of a circular coil will be $\frac{2\pi nI}{10r}$, where I is the current in amperes.

Similarly the unit of E.M.F. is chosen to be of the order of that of an ordinary electric cell; it is 100,000,000 or 10^8 absolute units, and is called the *volt*.

Thus for a complete circuit, rate of working

$$\begin{aligned} &= ei \text{ ergs per second} \\ &= E \cdot 10^8 \times I \cdot 10^{-1} \\ &= EI \times 10^7 \text{ ergs per second,} \end{aligned}$$

where E is now measured in volts, and I in amperes. Upon this system the practical unit of rate of working is the work done per second when one volt maintains a current of one ampere, and is called the *Watt*. We see then that rate of working = EI watts, and further that one watt = 10^7 ergs per second. The engineer's unit of rate of working, the horse-power, or 33,000 foot-pounds per minute, may be converted into watts by converting feet to centimetres, pounds weight to dynes, and minutes to seconds, when it will be found that one horse-power = 746 watts (approx.).

Again, the name *Joule* is given to the unit of work upon the practical system; it is the work done in one second when a current of one ampere is maintained by an E.M.F. of one volt, so that one watt = one joule per second.

The heat developed in any circuit by an electric current may

therefore be found in terms of the current flowing in it and the electromotive force which maintains the current, when the mechanical equivalent of one calorie, or as it is termed, Joule's equivalent, is known. This quantity has been determined in a number of ways, but the mean value may be taken to be 4.18×10^7 . Thus the conversion of 4.18×10^7 ergs into heat would raise one gramme of water one degree Centigrade. Then the rate of working may be expressed either in ergs per second or calories per second. Thus,

$$\begin{aligned} \text{Rate of working} &= EI \times 10^7 \text{ ergs per second,} \\ &= \frac{EI \times 10^7}{4.18 \times 10^7} = EI \times 0.239 \text{ calories per second} \end{aligned}$$

The practical unit of resistance is called the *ohm*, and is the resistance of a conductor for which there is a potential difference of one volt between its ends when a current of one ampere flows in it. Calling R the resistance of any conductor in terms of this unit, we see that

$$\frac{E}{I} = R, \text{ or, } E = IR.$$

$$\text{Again, one ohm} = \frac{\text{one volt}}{\text{one ampere}} = \frac{10^8 \text{ absolute units of p.d.}}{10^{-1} \text{ absolute unit of current}}$$

\therefore One ohm is 10^9 times the absolute unit of resistance.

$$\begin{aligned} \text{Also rate of working} &= EI = I^2R = \frac{E^2}{R} \text{ watts,} \\ &= EI \times 0.239 \text{ calories per second,} \end{aligned}$$

from which we see that for a given conductor, the heat produced in it per second is proportional to the square of the current.

Combination of Resistances.—From the definition of resistance given above, we may find the resistance of a number of conductors combined in series, that is, end to end, so that the same current flows through all of them; or in parallel, in which case they are all joined side by side between two points so that the current is divided between them.



FIG. 53.

(i.) *Series.*—The current I enters at the point A (Fig. 53), and flows through all the resistances, leaving at D. Then if there is no source of E.M.F. in any of the conductors,

$$\begin{aligned} \text{p d between A and B} &= IR_1 \\ \text{,, ,, B and C} &= IR_2 \\ \text{,, ,, C and D} &= IR_3 \end{aligned}$$

$$\therefore \text{p.d. between A and D} = IR = IR_1 + IR_2 + IR_3$$

where R is the effective resistance between A and D.

$$\therefore R = R_1 + R_2 + R_3 + \dots$$

That is, the combined resistance is the sum of the separate resistances.

(ii.) *Parallel or Multiple Arc* --In this arrangement of conductors the current enters at the point A (Fig. 54), and divides into a number of parts which unite again at B. Taking the total current I, equal to the sum of the separate currents,

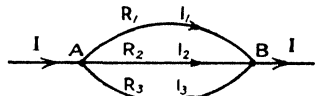

FIG. 54.

$$I = I_1 + I_2 + I_3.$$

If, now, the p.d. between A and B is equal to E,

$$E = IR = I_1R_1 = I_2R_2 = I_3R_3$$

where R is the effective resistance between A and B.

$$\therefore I = \frac{E}{R}, \quad I_1 = \frac{E}{R_1}, \quad I_2 = \frac{E}{R_2}, \quad I_3 = \frac{E}{R_3}.$$

$$\text{Hence,} \quad \frac{E}{R} = \frac{E}{R_1} + \frac{E}{R_2} + \frac{E}{R_3}.$$

Dividing by the common quantity E, and writing the expression for any number of conductors, we have—

$$\frac{1}{R} = \frac{1}{R_1} + \frac{1}{R_2} + \frac{1}{R_3} + \frac{1}{R_4} + \dots$$

Thus for conductors in parallel the combined conductance is the sum of the separate conductances, the conductance being defined as the reciprocal of the resistance.

To find the current in any one branch, we may note that

$$I_1 = \frac{E}{R_1} = \frac{IR}{R_1},$$

i.e. current in one branch = main current $\times \frac{\text{combined resistance}}{\text{resistance of branch}}$

Resistivity or Specific Resistance.—The resistance of a conductor depends upon its dimensions, and also upon the materials of which it is made. The resistance of a conductor of unit length and unit area of cross section is called its *resistivity* or *specific resistance*, S, and the inverse of this is its conductivity. The shape of the cross section is immaterial. Knowing the resistivity of the material we may readily find the resistance of a uniform conductor of any dimensions. For the conductor may be considered to consist of a number of unit con-

ductors S , so that if these are placed end to end we have a number l of these in series, where l is the length of the conductor. Since these unit conductors are in series, the resistance of this rod of unit section is Sl . If, now, a of these are situated in parallel, a is the total area of cross section, and the combined resistance is given by

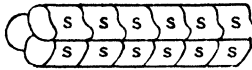

FIG. 55.

$$\frac{1}{R} = \frac{1}{Sl} + \frac{1}{Sl} + \frac{1}{Sl} + \dots \text{ to } a \text{ terms}$$

$$= \frac{a}{Sl}$$

$$\therefore R = \frac{Sl}{a}, \text{ or, } S = \frac{Ra}{l}$$

We can therefore find the resistance R if the resistivity S is known, and *vice versa*. The universal method for finding the resistivity is to measure the resistance of the conductor by one of the methods described in Chapter IV., and, knowing its dimensions, to calculate the resistivity. The resistivity of a number of substances is given in the second column of the Table below, in which the data are taken from Landolt and Bornstein's and from Kaye and Laby's Tables, the resistivity being in International Ohms per unit conductor (p. 397).

Substance.	Resistivity.	Range of temperature.	Temperature coefficient of resistivity.
Aluminium . . .	3.09×10^{-6} (Benoit) 0° C. 2.94 (Lees) 18° C.	$0^{\circ} - 100^{\circ}$ C.	0.00423 (Dewar and Fleming)
Copper . . .	1.59×10^{-6} (Mean of number) 18° C.	$0^{\circ} - 100^{\circ}$ C.	0.00428 (Dewar and Fleming)
Gold . . .	2.17×10^{-6} (Benoit) 0° C.	$12^{\circ} - 100^{\circ}$ C.	0.00377 (Dewar and Fleming)
Iron (soft) . . .	8.85×10^{-6} (Dewar and Fleming) 0° C.	$0^{\circ} - 100^{\circ}$ C.	0.00625 (Dewar and Fleming)
Lead . . .	1.99×10^{-5} (Benoit) 0° C.	$0^{\circ} - 100^{\circ}$ C.	0.00411 (Dewar and Fleming)
Mercury . . .	9.407×10^{-5} (International convention) 0° C.	$0^{\circ} - 15^{\circ}$ C.	0.000879 (Glazebrook)
Platinum (hard)	1.17×10^{-5} (Siemens) 0° C.	$0^{\circ} - 100^{\circ}$ C.	0.003669 (Dewar and Fleming)
Platinum (soft)	1.54×10^{-5} (Benoit) 0° C.	$0^{\circ} - 100^{\circ}$ C.	
Silver . . .	1.54×10^{-6} (Benoit) 0° C.	$0^{\circ} - 100^{\circ}$ C.	0.00400 (Dewar and Fleming)
Manganin (Cu 84, Ni 4, Mn 12)	4.76×10^{-5} (Dewar and Fleming) 0° C.	$18^{\circ} - 50^{\circ}$ C.	0.000018 (Phys. Reichsanst.)
Platinoid (Cu 62, Ni 15, Zn 22)	3.44×10^{-5} (Lees) 18° C.	18° C.	0.00025
Platinum-silver, 85% Ag, 15% Pt by volume	2.26×10^{-5} (Strouhal and Barns) 0° C.	$13^{\circ} - 100^{\circ}$ C.	(hard) 0.000255 (Comm. Brit. Ass.) (soft) 0.000344 (Comm. Brit. Ass.)

Electrolysis.—In the early years of the nineteenth century it was found that when an electric current flows in a solid or liquid substance which is not a metal, chemical action occurs, the products of the chemical action appearing at the conductors by which the current enters or leaves the substance. Non-metallic substances will not, as a rule, carry a current, unless some such chemical action occurs. To Faraday we owe the quantitative account of the phenomenon and the nomenclature now universally applied to it. The substance carrying the current, which in the act of carrying it undergoes decomposition, is called an *Electrolyte*, the conductors by which the current enters and leaves the electrolyte are called *Electrodes*, that at which the current enters being the *Anode*, and that at which it leaves, the *Kathode*, while the name *Electrolysis* is given to the whole process. The metals are liberated at the kathode, and the acid radicles at the anode; but owing to secondary reactions at the electrodes it often happens that the substance is dissolved in the electrolyte, or combines with the electrode, and in that case it does not appear in the free state.

The most common electrolytes are solutions of inorganic salts or acids in water. For example, if a current be passed through a dilute solution of sulphuric acid, platinum plates being used as electrodes, hydrogen appears at the kathode in the form of bubbles, and SO_4 is liberated at the anode,



This SO_4 does not appear in the free state, but with the water of the solution again forms sulphuric acid,

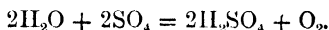

Bubbles of oxygen form at the anode, and if the gases at the kathode and anode be collected, it will be found that the hydrogen has twice the volume of the oxygen. If a copper anode had been employed, copper sulphate would have been formed in place of the oxygen.

Faraday's Laws.—As the result of Faraday's work, two laws were enunciated which bear his name.

(i.) The amount of decomposition is proportional to the current and to the time for which it passes.

(ii.) The amounts of different substances liberated by the same current, flowing for the same time, are proportional to the chemical equivalents of the substances.

From these two laws it follows that if the amount of any one substance liberated for a given current in a given time be known, the amount for any other substance may be found, provided that its chemical equivalent, which in the case of an element is the atomic weight divided by its valency, be known.

The mass of a substance liberated by one ampere in one second is called its *Electro-chemical Equivalent*.

The most accurately measured electro-chemical equivalent is that of silver, for which the most recent determination gives the value 0.0011183, and from this we can calculate that of any other substance. For example, the electro-chemical equivalent of di-valent copper is $0.0011183 \times \frac{63.6}{107.9 \times 2} = 0.000329$; the atomic weight of silver being 107.9, and that of copper 63.6.

The theory of electrolysis will be left to a later chapter, but we may note here that the constancy of Faraday's laws, and the ease with which the mass of the metallic substance liberated may be accurately determined, afford a ready means of measuring an electric current. The apparatus for carrying out the electrolytic measurements is called a *Voltmeter*, and there are three types of voltmeter frequently employed. In all cases the mass of substance liberated in a known time is observed, and the current calculated from the relation

$$M = Izt,$$

where z is the electro-chemical equivalent.

	Atomic weight (O = 16).*	Valency	Electro-chemical equivalent
Aluminium (Al)	27.1	3	
Antimony (Sb)	120.2	3	
Bismuth (Bi)	208.0	3	
Bromine (Br)	79.92	1	0.0008234
Cadmium (Cd)	112.40	2	
Calcium (Ca)	40.07	2	
Chlorine (Cl)	35.46	1	0.0003676
Copper (Cu)	63.57	1 or 2	0.0003293
Gold (Au)	197.2	3	
Hydrogen (H)	1.008	1	0.0001044
Iodine (I)	126.92	1	
Iron (Fe)	55.84	2 or 3	
Lead (Pb)	207.10	2	
Mercury (Hg)	200.6	1 or 2	
Oxygen (O)	16.0	2	0.0003293
Platinum (Pt)	195.2	4	
Potassium (K)	39.10	1	
Silver (Ag)	107.88	1	0.0011183
Sodium (Na)	23.00	1	0.0002384
Tin (Sn)	119.0	2 or 4	
Zinc (Zn)	65.37	2	0.0003387

Water Voltmeter (Hoffmann's Tube).—Water slightly acidulated with sulphuric acid is employed as the electrolyte, the hydrogen liberated at the cathode (Fig. 56) being collected in the graduated tube, on the passage of the current for a known time. Allowance

* International Atomic Weights for 1912. *Proc. Chem. Soc.*, 390, vol. 27, p. 205. 1911.

must be made for the fact that the gas is not under standard conditions. From the difference of levels of the liquid in the tube and the reservoir, the difference between the pressure of the hydrogen and the atmospheric pressure is known in terms of liquid column, and dividing by the density of mercury, we obtain the amount to be added to the height of the barometer to give the actual pressure of the hydrogen. From this must be deducted the maximum vapour pressure of water at the temperature of the tube, which may be found from Regnault's tables, in order to obtain the pressure of the dry hydrogen. Calling this P , and the temperature $t^{\circ} \text{C.}$, the volume reduced to 76 cms. pressure and 0°C. is—

$$V \times P \times 273 \\ 76 \times (t + 273),'$$

where V is the observed volume of hydrogen. The density of hydrogen at 0°C. and 76 cms. pressure being 0.08987 gr. per litre, the mass of hydrogen liberated is known, and the electro-chemical equivalent being 0.0001044, the current can be calculated.

Another form of water voltameter is shown in Fig. 57, the hydrogen and oxygen liberated escaping together, and the water vapour carried away with them being caught by the drying tube. The whole apparatus is weighed before and after the passage of the current, the loss in weight being that of the water decomposed by the current. The mass of water decomposed by the passage of one ampere for one second is—

$$0.0001044 \times \frac{(16 + 2.016)}{2} \\ = 0.0001044 \times 9.008,$$

0.0001044 being the electro-chemical equivalent of hydrogen.

For practical purposes this form of the apparatus is superior to the Hoffmann's tube, as the result depends upon weighing instead of upon measurement of volume, and further, the current may be passed for a much longer time, since in this case there is no question of the tube becoming filled with gas.

Copper Voltameter.—The kathode K (Fig. 58) consists of a thin copper sheet suspended from a stout conductor, and the anode of two sheets, one on either side of the kathode, so that the deposition of copper takes place on both sides of it. A and B are two wooden bars which carry the leads and which rest upon the edge of a jar or beaker containing a water solution of copper sulphate, made by

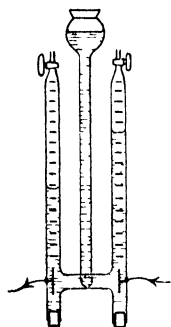

FIG. 56.

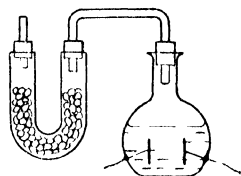

FIG. 57.

dissolving copper sulphate crystals in about four times their weight of water, a few drops of concentrated sulphuric acid being added. The current employed should not be too great, or the copper deposited will

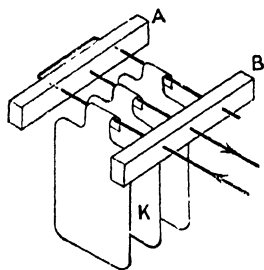

FIG. 58.

be in a soft, friable condition, and will therefore be liable to be washed off the plate. Provided that the current does not exceed one ampere for each 50 square centimetres of cathode, the deposit will be hard, bright, metallic copper. The cathode must first be well cleaned with emery paper, then, when the current in the circuit has been adjusted to a suitable value, the cathode is removed from the cell, well washed, dried, and weighed. It is then replaced in the cell and the current passed for a known time. The cathode is then removed and again washed, dried, and weighed. The

increase in weight, divided by the time and by 0.0003293, the electrochemical equivalent of copper, gives the value of the current.

In the process of electrolysis the copper sulphate is decomposed, the copper being liberated at the cathode, and SO_4 at the anode. The latter combines with the copper of the anode forming copper sulphate, so that the total amount of the copper sulphate in the solution remains unchanged. The loss in weight of the anode must not be taken as a measure of the current, since it includes not only the amount of copper which has gone into solution, but also any impurities which have become detached as the copper plate is dissolved.

This form of voltameter is very widely used for the calibration of ammeters and tangent galvanometers, as it is extremely simple in form and easily made, and by means of it the current may be determined to within an error of one part in several hundred.

Silver Voltameter.—When great accuracy is required, the silver voltameter of Lord Rayleigh's pattern may be employed (Fig. 59). The cathode is a platinum basin, PB, and the anode a plate of pure silver, the electrolyte being a solution of 15 to 20 grammes of pure silver nitrate in 100 grammes of water. Metallic silver is deposited upon the platinum dish, and, owing to its high electro-chemical equivalent, the mass deposited for a given passage of current is greater than in the case of copper in the copper voltameter. The acid radicle NO_3 liberated at the anode by the process of electrolysis forms silver nitrate with the metal of the anode itself, which is thereby dissolved. As this process of solution of the anode goes on, any impurities in the silver are liberated and these, together with the disintegrated silver, would fall upon the platinum plate if not prevented from doing so. To this end the anode is wrapped in a piece of pure filter paper, which, being permeated by the solution, will not prevent the passage of the current, but will catch the impurities. The current employed should not

exceed 0.03 ampere per square centimetre of surface of kathode. The current is calculated from the deposit and the time, just as in the previous cases.

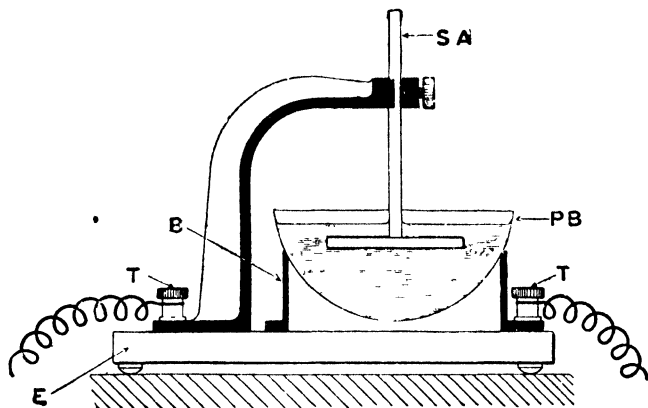

C.S.I.C.

FIG. 59.

Kirchhoff's Laws.—We owe to Kirchhoff two very useful generalisations, one relating to continuity of current in conductors, the other to the application of Ohm's law to complex arrangements of conductors. These generalisations are put into the form of two laws, known as Kirchhoff's laws, which are,

- (i) The algebraic sum of the currents which meet at any point is zero.
- (ii) In any closed circuit, the algebraic sum of the products of the current and resistance of each part of the circuit, is equal to the electromotive force in the circuit.

By the application of these two laws, many problems on the currents in a network of conductors may be solved, and the resultant resistance of the network found.

From the first law we see that in the case of a number of conductors meeting at a point (Fig. 60) the relation

$$i_1 + i_2 - i_3 - i_4 + i_5 + \dots = 0$$

holds between the currents, the positive sign being given to those which flow towards the point and the negative sign to those which flow away from it.

We shall see later that the first law is an expression of the fact that when the currents in a conductor are steady there is no accumulation of electricity anywhere.

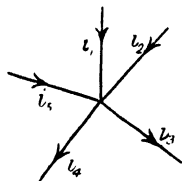

FIG. 60.

The second law applied to a circuit such as Fig. 61, leads to the equation

$$i_1 r_1 + i_2 r_2 + i_3 r_3 + i_4 r_4 = e.$$

If the circuit is a mesh of a network, it may happen that one or more of the currents is negative, and this fact must appear by a suitable change of sign in the equation.

Wheatstone's Net.—The most important application of Kirchhoff's laws is in connection with the problem of the *Wheatstone's Net*, an arrangement of conductors used very widely for the practical comparison of resistances.

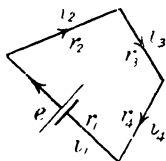

FIG. 61.

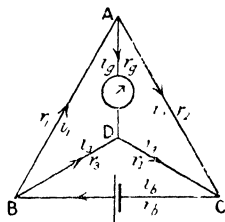

FIG. 62.

Six conductors are arranged in trilateral symmetry about the point D. If the diagram, Fig. 62, be looked upon as the plan of a tetrahedron of which ABC is the base and D the vertex, it will be seen that AD and BC are opposite sides of the tetrahedron, as are AB and DC, AC and BD, each pair being called conjugate conductors.

Applying Kirchhoff's first law to the points A, B, C, and D, in turn we have

for the point A,	$i_1 - i_2 - i_5 = 0$
" " B,	$i_6 - i_1 - i_3 = 0$
" " C,	$i_2 + i_4 - i_6 = 0$
" " D,	$i_3 + i_5 - i_4 = 0$

These four equations are not all independent, in fact, any one of them may be derived from the other three.

Kirchhoff's second law applied to the four possible meshes, gives the equations,

for mesh ABC,	$i_6 r_6 + i_1 r_1 + i_2 r_2 = e$
" ABD,	$i_1 r_1 + i_5 r_5 - i_3 r_3 = 0$
" ADC,	$i_2 r_2 - i_4 r_4 - i_5 r_5 = 0$
" DBC,	$i_3 r_3 + i_4 r_4 + i_6 r_6 = e$

Just as before, we can derive any one of these equations from the other three, so that they are not all independent.

If we take, say, the first three of each set we have six simple equations from which to determine the six unknown currents, $i_g, i_b, i_1, i_2, i_3, i_4$. The process of solving the six equations is a very tedious one, but by means of the three equations from the first law, the number of independent currents may be reduced from six to the three, so that the process of solving the equations need only be applied to the last set. This is virtually the same process as that suggested by Maxwell, of assuming three circuital currents $x, y,$ and z for the three meshes ABD, ADC, and DCB, and uniting the currents in the branches as the appropriate sums or differences of these three.

If, in our case, we take $i_g = g, i_b = b$ and $i_3 = x$; then from equation B, $i_1 = b - x$; from equation D, $i_4 = g + x$; and from C, $i_2 = b - g - x$. Substituting these values,

$$\begin{aligned} \text{ABC becomes } & br_b + (b - x)r_1 + (b - g - x)r_2 = e \\ \text{ABD becomes } & (b - x)r_1 + gr_g - xr_3 = 0 \\ \text{ADC becomes } & (b - g - x)r_2 - (g + x)r_4 - gr_g = 0 \end{aligned}$$

or, arranging the terms in $b, x,$ and $g,$

$$\left. \begin{aligned} (r_1 + r_2 + r_b)b - (r_1 + r_2)x - r_2g &= e \\ r_1b - (r_1 + r_3)x + r_1g &= 0 \\ r_2b - (r_2 + r_4)x - (r_2 + r_4)g &= 0 \end{aligned} \right\} \dots \alpha.$$

These equations may be solved by ordinary algebraic methods, but the process is very tedious. It would be a great advantage if the student would spend the time in reading the elementary theory of determinants, as found in Hall and Knight's Higher Algebra, rather than to attempt to solve the equations by unassisted algebraic methods. Thus solving for $g,$ we have

$$g = \frac{\begin{vmatrix} (r_1 + r_2 + r_b) & -(r_1 + r_2) & e \\ r_1 & -(r_1 + r_3) & 0 \\ r_2 & -(r_2 + r_4) & 0 \end{vmatrix}}{\begin{vmatrix} (r_1 + r_2 + r_b) & -(r_1 + r_2) & -r_2 \\ r_1 & -(r_1 + r_3) & +r_g \\ r_2 & -(r_2 + r_4) & -(r_2 + r_4 + r_g) \end{vmatrix}} \dots (\beta)$$

The numerator of this fraction is—

$$\begin{aligned} e \begin{vmatrix} r_1 & -(r_1 + r_3) \\ r_2 & -(r_2 + r_4) \end{vmatrix} &= e\{r_2(r_1 + r_3) - r_1(r_2 + r_4)\} \\ &= e(r_2r_3 - r_1r_4) \end{aligned}$$

Thus, when $r_1r_4 = r_2r_3,$ *i.e.* when $\frac{r_1}{r_2} = \frac{r_3}{r_4},$ the current g is zero, and if a galvanometer be placed in this branch, the current being produced by a battery in the b arm, the deflection will be zero when the resistances of the four arms 1, 2, 3, and 4 form a proportion. This is the

condition used in the various modifications of the Wheatstone's bridge commonly employed for comparing resistances.

Sensitiveness of Bridge.—On examining Fig. 62, it will be seen that if the battery and galvanometer change places, the same relation will hold for the current in the galvanometer to be zero. Any two conjugate conductors may be interchanged without disturbing the balance, and it might be thought that there would be no difference in the two arrangements. It is quite possible that the point of balance may be the same in the two cases, but in spite of that, the sensitiveness may not be nearly the same. To compare the advantages in the two cases, let us imagine that the balance is disturbed by a small amount, so that $r_2 r_3$ differs slightly from $r_1 r_4$. Now that the balance is not perfect we cannot find the current in the galvanometer without evaluating the determinant in the denominator of the equation for g . This is equal to

$$(r_1 + r_2 + r_b) \begin{vmatrix} -(r_1 + r_3) & r_g \\ -(r_2 + r_4) & -(r_2 + r_4 + r_g) \end{vmatrix} + (r_1 + r_2) \begin{vmatrix} r_1 & r_g \\ r_2 & -(r_2 + r_4 + r_g) \end{vmatrix} \\ - r_2 \begin{vmatrix} r_1 & -(r_1 + r_3) \\ r_2 & -(r_2 + r_4) \end{vmatrix}$$

that is,

$$(r_1 + r_2 + r_b)[(r_1 + r_3)(r_2 + r_4 + r_g) + r_g(r_2 + r_4)] - (r_1 + r_2)[r_1(r_2 + r_4 + r_g) + r_2 r_g] + r_2[r_1(r_2 + r_4) - r_2(r_1 + r_3)],$$

which when multiplied out, with the terms collected, becomes

$$r_b r_g (r_1 + r_2 + r_3 + r_4) + r_b (r_1 + r_3)(r_2 + r_4) + r_g (r_1 + r_2)(r_2 + r_4) \\ + [r_1 r_2 (r_3 + r_4) + r_3 r_4 (r_1 + r_2)].$$

Since the object of our investigation is to find whether it is more or less advantageous to place the battery and galvanometer as shown in Fig. 62 than with their positions interchanged, we may neglect the first and last terms in this expression, as their values will not be altered by interchanging r_b and r_g . Writing D_1 for the value of this denominator of equation β for the first position, as above, and D_2 its value when r_b and r_g are interchanged, we have

$$D_1 - D_2 = r_b [(r_1 + r_3)(r_2 + r_4) - (r_1 + r_2)(r_3 + r_4)] \\ + r_g [(r_1 + r_2)(r_3 + r_4) - (r_1 + r_3)(r_2 + r_4)] \\ = (r_b - r_g)(r_1 - r_4)(r_2 - r_3).$$

Now, when a balance is nearly but not quite attained, $r_2 r_3$ is very nearly equal to $r_1 r_4$, and the greater the current g for a given small difference between $r_2 r_3$ and $r_1 r_4$ the more sensitive will be the test for the point of balance. If, then, two of the resistances are very different in value to the other two, it may make a considerable difference whether we place the battery and galvanometer in the positions as shown or the reverse. Let us consider that r_1 and r_2 are great in comparison

with r_3 and r_4 ; then the last two expressions in brackets are both positive, and if in addition r_b be greater than r_g , $D_1 - D_2$ is positive, or $D_1 > D_2$. Hence, the denominator being greater in the first case than in the second, the current g is greater in the second than in the first, so that the second arrangement is the more sensitive, and the battery must be between A and D and the galvanometer between B and C. On the contrary, if $r_g > r_b$, then $D_2 > D_1$, and the battery and galvanometer must be as shown in the figure.

Thus, whichever (galvanometer or battery) has the greater resistance must be placed between the junction of the two arms having greater resistance and the junction of the two arms having less resistance.

Again, if one pair of resistances be extremely small, say r_1 and r_2 , then the numerator of equation β would be very small, and the current g would in turn be small, and the arrangement would then be insensitive under all conditions. This difficulty could not be got over by increasing the resistances r_3 and r_4 , as this would increase the denominator. Hence, the method of the Wheatstone's bridge is unsuitable for comparing two very low resistances; other methods must be employed (see p. 100).

Also it is an advantage to have the resistances of the battery and galvanometer as low as possible, as we then have as small a denominator of equation β as possible and therefore as large a current for any given want of balance.

An increase in e , the E.M.F. of the battery, is usually impracticable, as the resulting heating of the resistances, due to the larger current, would cause injury to the standard resistance coils.

Resistance of Network.—The effective resistance of the network from B to C may be found by solving the simultaneous equations a (p. 71), for the current in the battery, b ; then, if R is the effective resistance of the conductors through the network from B to C,

$$b = \frac{e}{R + r_b}.$$

R is evidently independent of the resistance of the battery, and we may, therefore, using a battery of negligible resistance, put $r_b = 0$, and obtain R from the relation $b = \frac{e}{R}$, or $R = \frac{e}{b}$.

From (α)—

$$b = \frac{\begin{vmatrix} e & -(r_1 + r_2) & -r_2 \\ 0 & -(r_1 + r_3) & +r_g \\ 0 & -(r_2 + r_4) & -(r_2 + r_4 + r_g) \end{vmatrix}}{\begin{vmatrix} (r_1 + r_2 + r_b) & -(r_1 + r_2) & -r_2 \\ r_1 & -(r_1 + r_3) & +r_g \\ r_2 & -(r_2 + r_4) & -(r_2 + r_4 + r_g) \end{vmatrix}}$$

Putting $r_b = 0$, and rearranging, remembering that $R = \frac{e}{b}$, we have—

$$R = \frac{\begin{vmatrix} (r_1 + r_2) & - (r_1 + r_2) & - r_2 \\ r_1 & - (r_1 + r_3) & + r_\rho \\ r_2 & - (r_2 + r_4) & - (r_2 + r_4 + r_\rho) \end{vmatrix}}{\begin{vmatrix} - (r_1 + r_3) & + r_\rho \\ - (r_2 + r_4) & - (r_2 + r_4 + r_\rho) \end{vmatrix}}.$$

a result which gives us the resistance of the Wheatstone's net.

Further, when $r_2 r_3 = r_1 r_4$ there is no current in the galvanometer circuit, and b is consequently independent of the resistance r_ρ , and it follows that the value of R in this case is unaffected by putting $r_\rho = 0$. The value of the numerator of the last equation, without r_b being omitted, has been found on p. 72, and putting r_b and r_ρ both equal to zero in this expression, it reduces to

$$r_1 r_2 (r_3 + r_4) + r_3 r_4 (r_1 + r_2).$$

And thus—

$$\begin{aligned} R &= \frac{r_1 r_2 (r_3 + r_4) + r_3 r_4 (r_1 + r_2)}{(r_1 + r_3)(r_2 + r_4)} \\ \frac{1}{R} &= \frac{r_1 r_2 + r_2 r_3 + r_1 r_4 + r_3 r_4}{r_1 r_2 r_3 + r_1 r_2 r_4 + r_1 r_3 r_4 + r_2 r_3 r_4} \\ &= \frac{r_1 r_2 + r_2 r_3}{r_1 r_2 r_3 + r_1 r_2 r_4 + r_1 r_3 r_4 + r_2 r_3 r_4} + \frac{r_1 r_4 + r_3 r_4}{r_1 r_2 r_3 + r_1 r_2 r_4 + r_1 r_3 r_4 + r_2 r_3 r_4}. \end{aligned}$$

Remembering that $r_1 r_4 = r_2 r_3$,

$$\begin{aligned} \frac{1}{R} &= \frac{r_1 r_2 + r_2 r_3}{(r_1 r_2 + r_2 r_3)(r_3 + r_4)} + \frac{r_1 r_4 + r_3 r_4}{(r_1 r_4 + r_3 r_4)(r_1 + r_2)} \\ &= \frac{1}{r_1 + r_2} + \frac{1}{r_3 + r_4}. \end{aligned}$$

A result which is in accordance with that obtained by the simple method on p. 63.

CHAPTER IV

THE ELECTRIC CURRENT (*continued*)

MEASUREMENTS

Galvanometers.—The name galvanometer is applied to those instruments which are used for the measurement or detection of very small currents. Although there is no absolute line of demarcation between these on the one hand, and ammeters which measure relatively large currents, and voltmeters which measure large differences of potential, on the other, still, the latter have as a rule a definite fixed scale, graduated to read amperes or volts, while the scale used with a galvanometer is not as a rule part of the instrument itself: and the value of the scale divisions, which for many purposes need not be known, is found for each experiment, when required, by some process of calibration.

In the case of the tangent galvanometer described in the last chapter, the expression for the current flowing in the coil is—

$$i = \frac{rH}{2\pi n} \tan \theta,$$

and for reasons connected with the use of such a galvanometer, r is always great. This is no disadvantage so long as the current to be measured is large, but if the current is extremely small, r must obviously be as small as possible, and at the same time n must be as great as possible. Thus for high sensitiveness, many turns of small radius must be employed. Obviously, the number of turns cannot be indefinitely increased without making the radius of the turns so great that they are of very little value, and even act detrimentally by unduly increasing the electrical resistance of the galvanometer.

Having reached the limit of any increase of sensitiveness obtained by modifying the coil, we then turn our attention to the method of measuring the deflection. The scale and pointer method is only applicable for very rough instruments, and is replaced by the scale and mirror method described on p. 8. The scale being situated at some distance from the needle, and the rotation of the reflected beam of light being double that of the mirror, it follows that for deflections of a

considerable number of scale dimensions, the angle turned through by the needle is so small that $\tan \theta$ may be replaced by θ itself, and this may be taken as proportional to the deflection in divisions on the linear scale. This is thoroughly justified if the reading is near the middle of the scale, but if the deflections are large the scale must be directly calibrated.

The calibration of a galvanometer scale may be most easily effected by means of a standard cell and a high resistance box. The box, the cell, and the galvanometer are joined in simple series and the resistance adjusted until the deflection is the greatest allowable. The resistance and E.M.F. being known, the current is calculated ($\text{current} = \frac{e}{r}$). On increasing the resistance by suitable steps, other readings of the deflection may be obtained, and the corresponding current calculated, and the result may very suitably be represented by means of a curve, deflections being abscissæ and milli-amperes (thousandths of an ampere) or micro-amperes (millionths of an ampere) ordinates.

If the controlling magnetic field, H , which brings the needle into

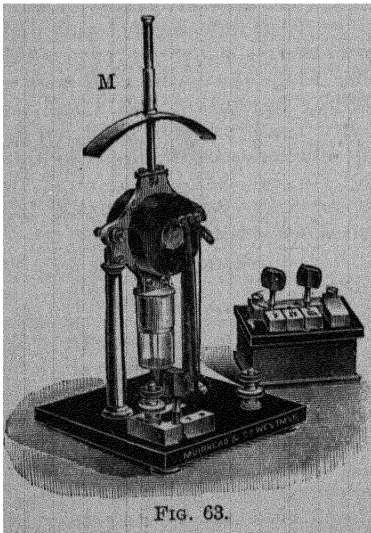

the plane of the coil, when no current is flowing, is the horizontal component of the earth's field, the range of sensitiveness of any given galvanometer is restricted; the only changes that can be made are effected by altering the coils or the method of reading the deflection; but if H can be varied, we have a great extension of the range of usefulness of the instrument. This is usually accomplished by means of a controlling magnet M (Fig. 63). Thus, if H be increased by lowering M , its S pole pointing north, and its N pole pointing south, we see that a given current will produce a less deflection, but if the N pole of M point north, or if instead

M be raised, the controlling field H is weakened, and the given current will produce a greater deflection. Thus the sensitiveness may be considerably altered by means of the controlling magnet.

The use of a controlling magnet has the further advantage that the spot of light may by means of it be easily adjusted to the zero of the scale.

Another device for increasing the sensitiveness is to arrange the

suspended magnetic system in such a way that the controlling field exerts an extremely small turning effect upon it. Two magnets are

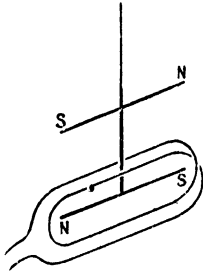

FIG. 64.

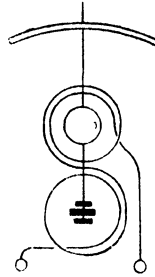

FIG. 65.

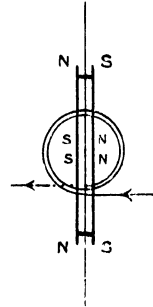

FIG. 66

connected rigidly together in such a way that the couples exerted by the controlling field upon them are very nearly equal and opposite. They must not be exactly equal and opposite, in which case the system is said to be *astatic*, or the control would be zero, and the arrangement would be unworkable. The coil only surrounds one of the needles (Fig 64), so that the deflecting couple acts on one of them only. In the Kelvin type of instrument two coils are employed, one surrounding each magnet, the coils being so connected that the couples due to the current both turn the systems of needles in the same direction (Fig. 65). A further arrangement due to Professor Broca, modified by Dr Harker, is shown in Fig. 66. Two steel wire magnets are rigidly attached together vertically, one of which has N poles at its end, and consequent S poles in the middle, and the other S poles at the ends with consequent N poles in the middle. This arrangement allows powerful magnets to be used without having a large moment of inertia for the moving system.

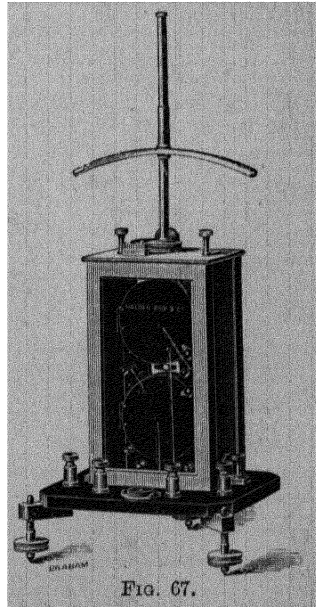

FIG. 67.

Fig. 67. illustrates a galvanometer of the Kelvin type made by Messrs. Nalder Bros. & Co

The Suspended Coil galvanometer has largely superseded the

galvanometer with the suspended magnet, for two important reasons—the instrument is not susceptible to disturbance by varying external magnetic fields, and the suspension is much stronger. On the contrary, its sensitiveness cannot be varied at will, and the damping is usually much greater. This latter is not always a disadvantage; in fact, for deflection measurements and those involving the finding of an electric balance as in the case of the Wheatstone's bridge, it may be a great advantage, but in measurements of the ballistic type, as we shall see in Chapter IX., it is a serious objection.

The principle involved in the use of this type of galvanometer must be deferred to Chapter IX., but on general grounds it may be seen that if a magnet experiences a couple due to the current in a coil, the coil experiences an equal and opposite couple, so that if the magnet be fixed and the coil suspended, the latter will be deflected when a current flows in it, and further, the couple is proportional to the current. To make this change, a radical alteration in design is necessary. Since the magnet is fixed we may make it as large and heavy as we please, while on the other hand, the coil, being suspended, must be as light as possible.

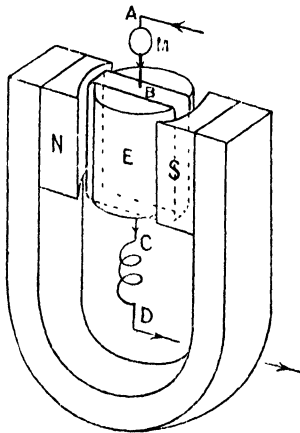

FIG. 68.

A typical arrangement for this form of galvanometer is shown in Figs. 68 and 69. A permanent magnet, usually of the horseshoe type, has soft iron pole-pieces N and S. The coil B, which is commonly rectangular, is suspended between these pole-pieces by a fine phosphor-bronze strip, which also serves as a conductor to bring in the current. After passing round all the turns of the coil, the current passes out by means of the second phosphor-bronze strip CD.

When the current flows, the coil experiences a couple, and will rotate until the couple due to the twist in the suspension becomes equal and opposite to the deflecting couple. The couple due to this twist in the suspension is proportional to the angle of twist itself, and the coil should be always in a magnetic field of the same strength. To ensure this the soft iron cylinder E is situated between the pole faces, and serves the double purpose of making (by the presence of the poles upon

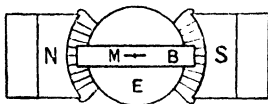

FIG. 69.

it) the field stronger and also of making it radial, as shown in the plan (Fig. 69). We shall see in Chapter IX. that the couple acting on the coil is proportional to the current i , to the number of turns n ,

and to the area of each turn A , and to H , the strength of field in which the sides of the coil are situated.

$$\therefore \text{Couple} \propto iAn^2l.$$

The controlling couple is proportional to the deflection θ , and to the couple c for unit twist (one radian) of the suspension, the upper end being fixed. Thus, for equilibrium

$$iAnH \propto c\theta, \text{ or, } i \propto \frac{c}{AnH} \theta.$$

Hence for a well-designed instrument the current is proportional to the deflection itself, since the field is certainly of constant value until θ attains much larger value than that occurring in any probable experiment. To increase the sensitiveness, c may be diminished, and A , n , and H increased. c cannot be diminished without limit, as the suspension must be strong enough to carry the coil. It is usually made of phosphor-bronze, as this has a tensile strength approaching

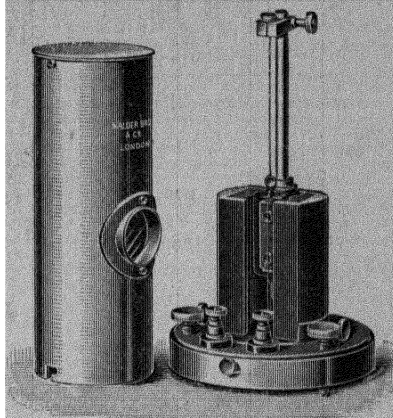

FIG. 70.

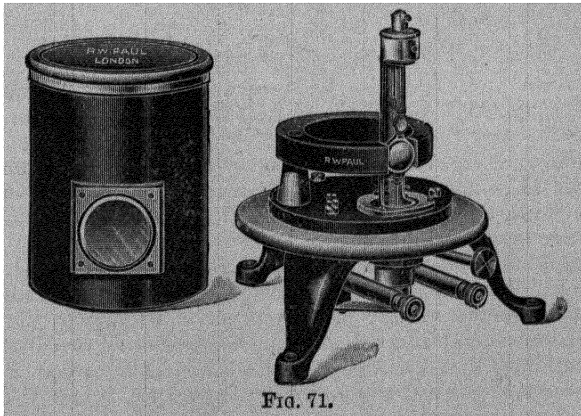

FIG. 71.

that of steel and is not readily oxidisable. The coil is made as light as possible by constructing it of thin high-conductivity insulated copper wire, but it may be noticed that we can never use as great a

number of turns of wire in the coil as in the case of the suspended magnet instrument, and for this reason the suspended coil galvanometer has generally a lower resistance. The loss of sensitiveness due to having fewer turns is, however, made up for by the very high value of the magnetic field employed. The permanent magnets are generally built up of several hard-steel horseshoe magnets to ensure permanence and great strength of field.

Galvanometers of the suspended coil type are frequently called d'Arsonval galvanometers after their inventor.

In Figs. 70 and 71 are two types of galvanometer having a single

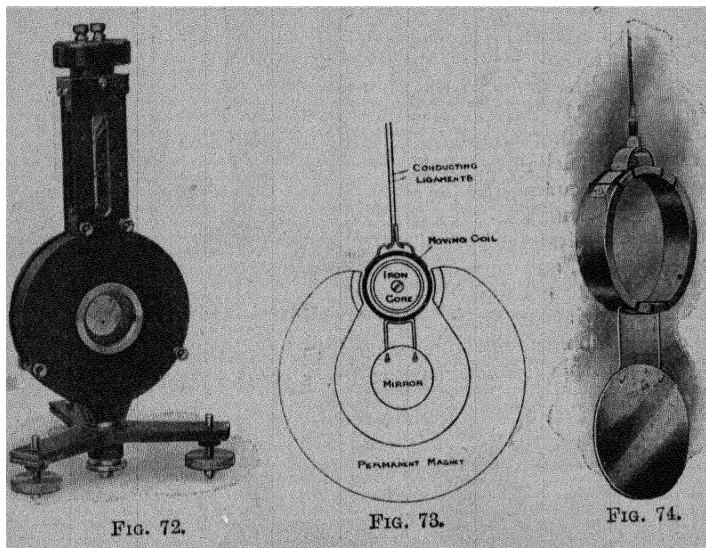

FIG. 72.

FIG. 73.

FIG. 74.

suspension, and Fig. 72 is a galvanometer of the Crompton type, in which the suspension is bifilar, the current passing down one of the pair of metallic strips and up the other. The details of the suspension and coil are given in Figs. 73 and 74.

In the **Thermo Galvanometer** due to Duddell, the heating produced in a fine wire is measured by an arrangement similar to that used in the Boys' radio-micrometer. A loop of silver wire hangs between the poles of a permanent magnet and the loop ends in two little pieces, one of antimony and the other of bismuth. These are in contact at their lower extremities, and are situated over the heater H (Fig. 75), which carries the current to be measured. When a temperature difference exists between the lower Bi-Sb junction and the rest of the circuit, a current proportional to this temperature difference flows in the loop, which then rotates until the torsion in the suspending quartz

fibre F brings it to rest. The rate of production of heat in H is proportional to the square of the current, and this is also found to be proportional to the deflection. The heaters are made of various resistances from 4 ohms to 1000 ohms, those of lower resistance being metal wires and those of high resistance consisting of a deposit of platinum on quartz.

With a scale at a distance of one metre, a current of 110 micro-amperes gives a deflection of 250 millimetres, using a 1000-ohm heater, and with a 4-ohm heater a p.d. of 7 millivolts gives a deflection of 250 millimetres. The great advantage of the instrument lies in the fact that it is equally applicable to the measurement of direct or alternating currents, and on being calibrated for one, may be used to measure the other, and it is therefore useful for the measurement of high-frequency oscillating currents of a few micro-amperes.

Sensitiveness of Galvanometer.—The *Figure of Merit* of a galvanometer is the current which will produce a deflection of one scale division. This depends upon the distance of the scale from the galvanometer and the size of division, and thus for facility in comparing different galvanometers it is usual to employ a scale of millimetres, placed at a distance of one metre from the mirror of the galvanometer. Provided that the deflection is not too large, we see that the current is proportional to the deflection, both for the suspended magnet and the suspended coil type of galvanometer, and therefore we can obtain the figure of merit by observing the deflection for a given current, as in the calibration described on p. 76. Dividing the current by the deflection the figure of merit is obtained.

There is considerable difficulty in making a comparison of the efficiency of different galvanometers, since this depends so much upon the use to which the instrument is to be put. It might happen that an extremely small current produces a considerable deflection, and yet the resistance of the galvanometer may be so great that it is unsuitable for some purposes, as, for example, making measurements by the Wheatstone's bridge. If a constant p.d. be maintained between the terminals of a given galvanometer, the deflection is independent of the resistance of the coils, provided that all the turns are equally effective in producing magnetic field, for the field is then proportional to the number of turns. But, on the other hand, the resistance is also proportional to the number of turns, so that the current corresponding to the given p.d. will vary inversely as the number of turns, and the deflection, being proportional to the field and the current, will remain unaltered.

Again, the moment of inertia of the suspended part does not affect the steady deflection for any given current, but it does affect the

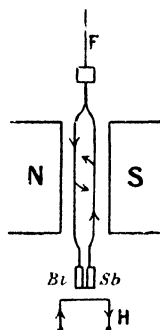

FIG. 75.

period of swing and the time for which the needle goes on swinging, and a large moment of inertia may, therefore, render a sensitive galvanometer unsuitable for bridge work and for measurements in which a steady deflection is to be rapidly obtained. And, further, the suspended magnet galvanometer is usually provided with a moveable controlling magnet, so that the controlling field, and therefore the sensitiveness, may be varied between wide limits.

For these reasons it has been suggested that the sensibility of a galvanometer should be defined as the number of scale divisions deflection for a current of one micro-ampere when the scale is at a distance of 1000 scale divisions from the mirror, reduced to the corresponding value for the same rate of expenditure of energy when the resistance of the galvanometer is one ohm and the period of vibration one second.

Let the deflection be θ scale divisions for a current of one micro-ampere when the resistance is R ohms and the time of vibration T seconds. The rate of working is now $R \times 10^{-12}$ watts (since current is one micro-ampere = 10^{-6} amperes), and therefore to maintain the same rate of working with the resistance changed to one ohm, the current would be \sqrt{R} micro-amperes, and the deflection for one micro-ampere would, under the new conditions, be $\frac{\theta}{\sqrt{R}}$. To reduce the deflection to correspond to a period of vibration of one second, remember that $T = 2\pi\sqrt{\frac{I}{MH}}$ in the case of a vibrating magnet, where H is the controlling field (p. 23);

$$\therefore H \propto \frac{1}{T^2}.$$

$$\text{But deflection} \propto \frac{1}{H} \text{ (p. 75);}$$

$$\therefore \text{Deflection} \propto T^2.$$

Hence to find the deflection if the periodic time were reduced to one second, we must divide by T^2 .

$$\therefore \text{Sensibility} = \frac{\theta}{T^2 \sqrt{R}}.$$

A similar process of reasoning applies to the suspended coil galvanometer, for in this case $T = 2\pi\sqrt{\frac{I}{c}}$, where c is the restoring couple for unit twist in the suspension, and deflection $\propto \frac{1}{c}$ (p. 79).

∴ Deflection $\propto T^2$.

Galvanometer Resistance.—The resistance of the galvanometer may vary between wide limits, but that of the suspended magnet type is, in general, greater than that of the suspended coil. The latter may have any resistance up to 2000 or 3000 ohms, but in the case of the suspended magnet instrument it reaches in exceptional cases, as much as 300,000 ohms, although 4000 to 6000 ohms is a usual value.

There are many methods of measuring the resistance of a galvanometer, but undoubtedly the most accurate is to clamp the coil and treat the galvanometer as an ordinary conductor, and measure its resistance by comparison with a standard, using the metre bridge or Post Office box. This involves the employment of a second galvanometer, which presents no difficulty in a physical laboratory; but there are several methods of determining the resistance without the use of this second galvanometer. For example, in Kelvin's method, described on p. 98, the galvanometer itself occupies one arm of a Wheatstone's bridge. The following two simple methods will give the resistance approximately.

If the galvanometer has a low resistance G , connect it in series with a cell of E M.F. E volts, and a resistance R_1 ohms in which resistance R_1 ohms is used.

Then, $I_1 = \frac{E}{G + R_1}$, assuming that the resistance of the cell is negligible. Now change the resistance in the box to R_2 ohms, when

$$I_2 = \frac{E}{G + R_2}$$

$$\therefore \frac{I_1}{I_2} = \frac{G + R_2}{G + R_1}, \quad G = \frac{R_2 I_2 - R_1 I_1}{I_1 - I_2}$$

I_1 and I_2 are proportional to the deflections in the case of a reflecting galvanometer, and to the tangents of the deflections in the case of a tangent galvanometer. The method is applicable when the galvanometer is not very sensitive, but in the case of a delicate instrument, R would have to be so great in order to produce a reasonably small deflection, that the method is useless, and the next method may be employed. A conductor of resistance r_1 is placed in parallel with the galvanometer and another resistance R_1 in series (Fig. 76).

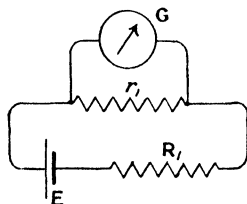

FIG. 76.

Then R_1 being usually very great in comparison with the resistance of the cell,

$$\text{Current in galvanometer, } I = \frac{E}{R_1 + \frac{r_1 G}{r_1 + G}} \cdot \frac{r_1}{r_1 + G}$$

If now r_1 be changed to r_2 , and R_1 be changed to the value R_2 , such that the current I in the galvanometer is the same as before,

$$\frac{E}{R_1 + \frac{r_1 G}{r_1 + G}} \cdot \frac{r_1}{r_1 + G} = \frac{E}{R_2 + \frac{r_2 G}{r_2 + G}} \cdot \frac{r_2}{r_2 + G}$$

$$\frac{r_1}{R_1 r_1 + R_1 G + r_1 G} = \frac{r_2}{R_2 r_2 + R_2 G + r_2 G}$$

$$G = \frac{r_1 r_2 (R_1 - R_2)}{r_1 R_2 - r_2 R_1}$$

Galvanometer Shunts.—Resistances are sometimes placed in parallel with the galvanometer to reduce the sensitiveness, by offering

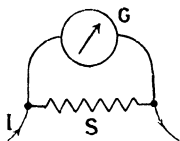

FIG. 77.

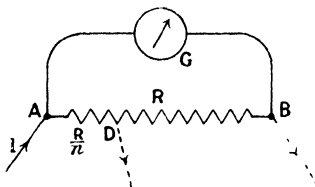

FIG. 78.

an alternative path to the current, so that only a fraction of it goes through the galvanometer. Thus, if the galvanometer resistance be G , and that of the shunt S (Fig. 77), then for the current I flowing in the main circuit, that in the galvanometer is $I \cdot \frac{S}{G + S}$. With the older galvanometers, boxes of shunts were supplied, whose resistances were respectively $\frac{1}{9}$, $\frac{1}{99}$, and $\frac{1}{999}$ of that of the galvanometer, and in this case $\frac{S}{G + S}$ has the value $\frac{1}{10}$, $\frac{1}{100}$, or $\frac{1}{1000}$, so that the sensitiveness of the galvanometer is reduced 10, 100, or 1000 times by the use of the proper shunt. Each galvanometer had its own shunt, which sometimes led to great inconvenience, and hence the advantage of the Ayrton and Mather Universal Shunt, which may be applied to any galvanometer.

The high resistance R is placed in parallel with the galvanometer, and the current I enters at A and leaves at B , Fig. 78,

$$\text{current in galvanometer} = I \frac{R}{G + R}$$

If now the point at which the current leaves be transferred to D, such that resistance AD = $\frac{1}{n}$ (resistance AB), the two circuits AD ($\frac{R}{n}$), and AGBD ($G + R - \frac{R}{n}$), are in parallel, and

$$\text{current in galvanometer} = I \frac{\frac{R}{n}}{\frac{R}{n} + G + R - \frac{R}{n}} = \frac{I}{n} \frac{R}{G + R},$$

that is, it is $\frac{1}{n}$ of the previous current.

By having a number of points such as D, for which $n = 1, 10, 100, 1000, \text{etc.}$, the effect of the shunt may be conveniently varied. Fig. 79 shows the arrangement sometimes adopted in the Ayton and Mather shunt: G and G are connected to the galvanometer and L L are the circuit terminals. With the rotating arm as shown, the value of the shunt is $\frac{1}{10}$.

It should be noted that in moving the point of contact from B to D (Fig. 78), the effective resistance between the leads falls from

$$\frac{GR}{G + R} \quad \text{to} \quad \frac{\frac{R}{n}(G + R - \frac{R}{n})}{\frac{R}{n} + G + R - \frac{R}{n}}$$

i.e. to $\frac{R}{n} \cdot \frac{(G + R - \frac{R}{n})}{G + R}$

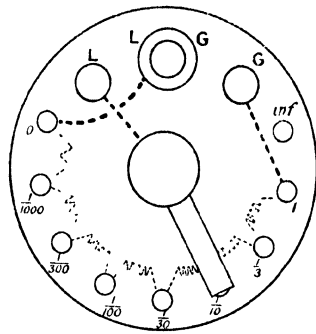

FIG. 79.

and the main current may be thereby altered. For the main current to be unchanged, these values of the resistance must be the same,

$$\therefore G = \frac{G + R - \frac{R}{n}}{n}, \text{ or, } R = nG.$$

Thus for any given value of the shunt, say $\frac{1}{10}$, the effective resistance of the circuit is unchanged on employing the shunt, provided that the

resistance AB is ten times the galvanometer resistance. The sensitiveness of the galvanometer is reduced on attaching the universal shunt, in the ratio $1 : \frac{R}{G + R}$, that is by $100\left(1 - \frac{R}{G + R}\right)$ or $100 \frac{G}{G + R}$ per cent.; but this is $100 \frac{G}{G + nG}$, when $R = nG$, or $\frac{100}{1 + n}$. In the case when $n = 10$, this amounts to 9.1 per cent., which is unimportant, and when $n = 100$ or 1000 it is quite negligible. The resistance of the whole shunt should therefore be at least 100 times that of the galvanometer.

Voltmeters.—Although the variety of voltmeters in use is very great, and many different principles are used in their construction, we

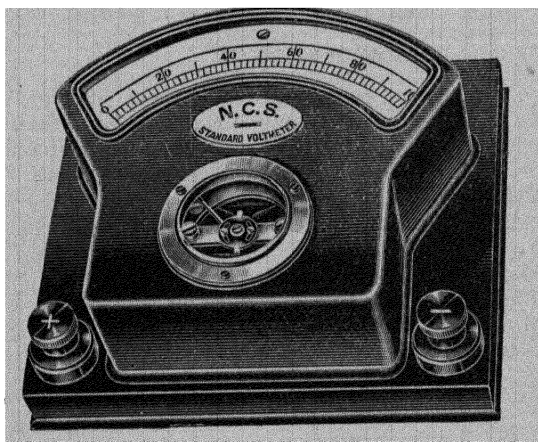

FIG. 80.

may broadly distinguish between the electromagnetic type, which is simply a galvanometer of low sensibility having a fixed scale graduated to read volts, and the electrostatic type, which is a modified form of electrometer, the description of which will be left to Chapter VI. But one characteristic is common to them all; they must have very high resistance, the reason being that in connecting them between the two points whose p. d. is required, they must take only an infinitesimal current, so that no appreciable disturbance of the circuit is produced, and the heat produced by the current in the instrument itself shall be negligible. In the electromagnetic type of instrument the coil is situated in a strong radial magnetic field, as in the case of the galvanometer, but the control is produced by a spiral spring usually made of phosphor-bronze, and the coil turns upon two

jewelled pivots. Fig. 80 is a voltmeter made by Messrs Nalder Bros. and Thompson, Ltd.

In Fig. 81 is shown the mode of suspension of the coil in an instrument made by Mr. Robt. W. Paul, which is supplied either as milli-voltmeter or as a micro-ammeter according to the scale attached. It also

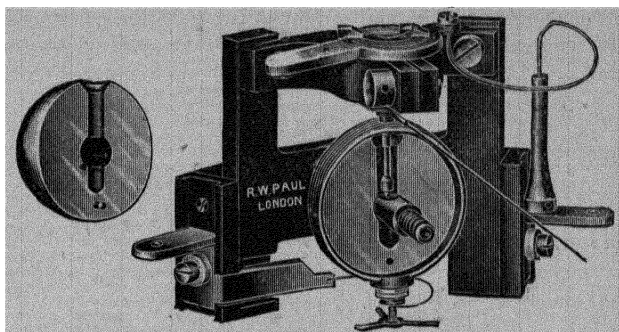

FIG. 81.

serves the purpose of a galvanometer when great sensitiveness is not required. It is called a single pivot galvanometer on account of the fact that the coil is suspended by one pivot only, which is situated at the centre of the spherical soft iron core as shown in the figure.

Ammeters.—A voltmeter may be used in conjunction with a shunt of low resistance to serve the purpose of an ammeter. If the shunt AB, Fig. 82, be placed in the circuit in which the current is to be measured, and the voltmeter joined to A and B, then if the resistance between A and B be known (say R ohms), the current is also known, since $I = \frac{E}{R}$.

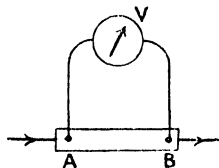

FIG. 82.

If R be $\frac{1}{10}$ ohm, then the scale of volts multiplied by 10 will serve as a scale of amperes. This of course assumes that the resistance of the voltmeter is so high that the current in it is inappreciable, but even when this is not quite the case the instrument may be calibrated as an ammeter by means of the voltmeter or by comparison with a standard current balance (see p. 244).

Many instrument makers place the shunt in the case of the instrument, and others supply sets of shunts, which enormously increase the range, in some cases up to several thousand amperes (Fig. 83).

In all cases the resistance of an ammeter must be very small; in the first place so that no disturbance is made in the circuit in which it is placed, and secondly because the heat produced in the instrument must, in spite of the large current, be negligible.

Hot Wire Instruments.—The heat produced by the passage of the current has also been employed in the construction of ammeters and voltmeters. The current passes through a fine wire which is thereby heated. The expansion is observed by some mechanical multiplying arrangement. The Cardew voltmeter is an example of this form of instrument. The advantage lies in the fact that the direction of movement of the pointer is independent of the direction of the current, and the instrument can therefore be used for measuring alternating

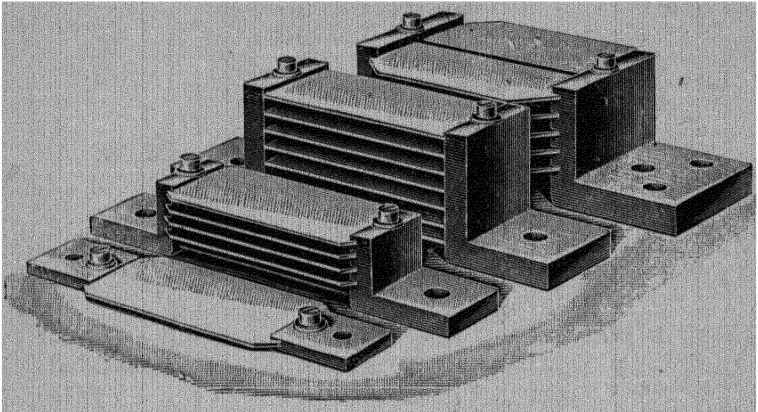

FIG. 83.

currents. The hot wire instruments, however, are very liable to change of zero, and the fact that the heating is proportional to the square of the current renders the scale uneven, and further, the multiplying mechanism is a frequent source of uncertainty.

Soft Iron Instruments.—*Soft Iron* ammeters also are constructed, which read satisfactorily on both continuous and alternating current circuits. The principle of such an instrument is illustrated in Fig. 84. The current to be measured passes round a coil wound upon a brass cylinder, and therefore gives rise to a magnetic field parallel to the axis of the coil. Two soft iron bars, A and B, are situated in this field, with their axes parallel to it, and are therefore magnetised when the current flows in the coil, and to a degree depending upon the strength of the current. A is fixed to the brass cylinder, and B is part of a light framework pivoted upon centres O situated in the axis of the coil. When A and B are magnetised, the ends situated together are poles of the same kind, that is both N or both S, and the two bars therefore repel each other. The force of this

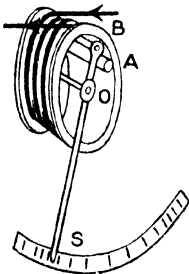

FIG. 84.

ends situated together are poles of the same kind, that is both N or both S, and the two bars therefore repel each other. The force of this

repulsion is proportional to the product of the two pole strengths, and each pole depends upon the strength of current, and hence the repulsion depends upon the square of the current. The control is usually gravitational, the moving system being so balanced that the pointer *S* is at zero on the scale when no current is flowing. The relation between deflection and current is complicated, so that the scale must be calibrated by direct comparison with an ampere balance; the scale is found to be more open in the middle than at the ends.

Since the deflection depends upon the square of the current, its direction is independent of that of the current, and an alternating current will therefore produce a deflection. This type of ammeter, calibrated to read alternating currents, is very widely used.

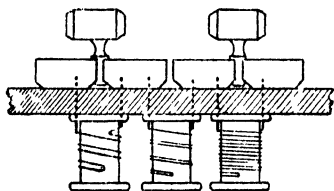

FIG. 85.

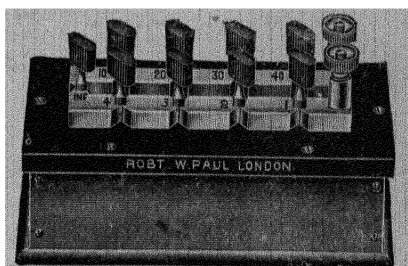

FIG. 86.

Resistances.—For purposes of electrical testing, it is usual to arrange the standard sets of resistances in boxes, and the variety of ways in which this is done is very great. One very common arrangement is shown in Fig. 85. The wire whose resistance is approximately that required, is soldered one end to each of the brass blocks, which are themselves screwed to the ebonite base. The wire, which is usually of manganin on account of its small temperature coefficient, is then doubled and wrapped round the bobbin as shown, and afterwards soaked in melted paraffin wax. The plugs are ground to fit into conical holes between the brass blocks, so that on inserting any given plug the corresponding resistance coil is short circuited.

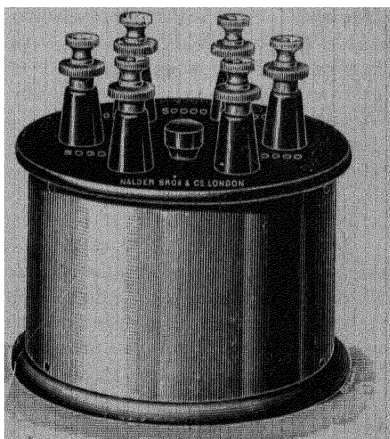

FIG. 87.

Fig. 86 is a box of the ordinary type made by Mr. R. W. Paul, and Fig. 87 a box of high resistance made by Messrs. Nalder Bros. & Co., the total resistance of which is 100,000 ohms, the terminals being mounted on tall pillars to improve the insulation. This becomes necessary when the resistance of the coils is of the same order of magnitude as that due to leakage between the terminals, over the surface of the ebonite. Fig. 88 is a convenient form of dial box by Messrs. Nalder Bros. & Co.

Owing to the change of resistance with temperature, resistance

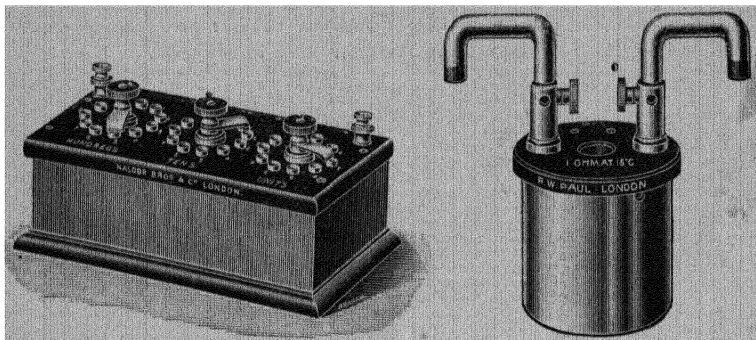

FIG. 88.

FIG. 89.

coils used for accurate purposes are provided with a thermometer to enable the temperature to be observed at the time of experiment. In Fig. 89 is shown a standard resistance coil of the pattern used by the Reichsanstalt, Berlin. The terminals are stout copper conductors, which are amalgamated at the tips to ensure good electrical contact with the mercury cups in which they rest. The whole is immersed in a liquid bath to maintain steadiness of temperature, and the hole enables a thermometer to be inserted so that the bulb shall be as near as possible to the resistance wire itself.

Measurement of Resistance.—The easiest method of comparing resistances is that of *simple substitution*. A cell of steady E.M.F., which need not be known, is placed in series with a galvanometer, a resistance box, and the resistance to be determined. The current is adjusted to a suitable amount either by changing the resistance in the box or by shunting the galvanometer. On removing the unknown resistance from the circuit, the current is increased, and may be brought back to its original value by increasing the resistance in the box by an amount equal to that of the resistance removed, which is therefore known.

The *deflection method* may be employed when the resistance to be measured is sufficiently high; the deflection θ being observed when the unknown resistance R is in circuit. This is then replaced by a

known standard resistance R_1 and the deflection θ_1 observed (Fig. 90). If E is the E.M.F. of the cell, B its internal resistance, and G the resistance of the galvanometer—

$$I = \frac{E}{R + B + G}, \quad I_1 = \frac{E}{R_1 + B + G}$$

$$\frac{I}{I_1} = \frac{R_1 + B + G}{R + B + G} = \frac{\theta}{\theta_1}$$

If R and R_1 are very great in comparison with B and G , $\frac{R}{R_1} = \frac{\theta_1}{\theta}$.

The method is only employed in measuring very great resistances, such as that of the insulation of an electric cable, which is generally of the order of millions of ohms. The cable is immersed in a tank of

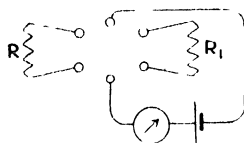

FIG. 90.

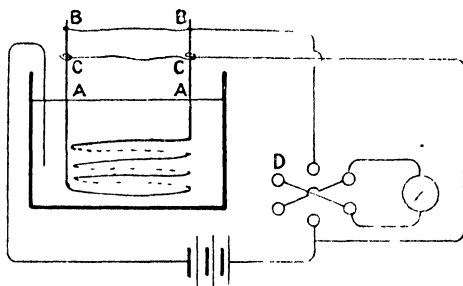

FIG. 91.

water, and the current passed from the core B to the water of the tank, passing through the insulating layers of the cable. It will be seen that a leakage may occur over the surface of the insulation from A to B (Fig. 91), this current causing the results obtained to be false. To get over this difficulty Price¹ has suggested that a wire, C , be bound round the insulation near the end of the cable and so connected to the rest of the circuit that this disturbing current will not pass through the galvanometer. The current in the galvanometer may conveniently be reversed by means of the Pohl's commutator, shown at D , and the mean of the readings on each side of the zero, taken as the deflection.

A more direct method of measuring resistance is sometimes employed when the conductor is carrying current, as, for example, in the case of an incandescent lamp, the resistance of which, when hot, differs greatly from that when cold. The ammeter A (Fig. 92) indicates the current in the lamp, and the voltmeter V the potential difference between its terminals. By division we can obtain the resistance in

¹ W. A. Price, *Electrical Review*, vol. 37, p. 702. 1895.

ohms. The method does not admit of very great accuracy, but this is rarely required in such a case.

On altering the current by means of the variable resistance R, the resistance of the lamp for different currents may be found, and if, instead of dividing the p.d. by the current, we multiply them together, the result obtained is the power in watts absorbed by the lamp. The candle-power for different currents may be found by the ordinary photometric methods. A carbon filament lamp has about 50 per cent. less resistance when hot than when cold, while for a metallic filament the resistance when hot is two or three times that when cold.

Wheatstone's Bridge.—The method of the *Wheatstone's net*, described in the last chapter, affords the most accurate and frequently used method of comparing resistances, and it has the great advantage that it is a null method, the galvanometer being required to detect a want of balance and not to measure a deflection.

Fig. 93 (i) is a diagrammatic representation of the Wheatstone's net, and Fig. 93 (ii) shows the arrangement used in the *Post Office box*.

We have seen on p. 71 that when $\frac{P}{Q} = \frac{R}{S}$ the current in the galvanometer is zero. Hence, if the ratio $\frac{P}{Q}$ and the value of R in ohms be known, the resistance S can be calculated. In the Post Office box the

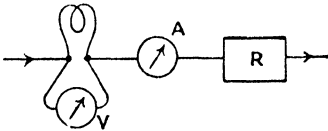
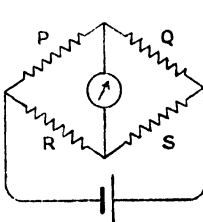

FIG. 92.



(i)

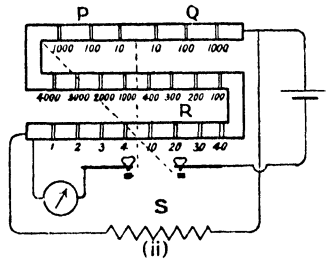

FIG. 93.

arms P and Q usually each consist of three resistances of 10, 100, and 1000 ohms respectively, so that any decimal ratio from 1 : 100 up to 100 : 1 may be used. The third arm R is an ordinary set of resistances, and the unknown resistance S, which is to be measured, is made the fourth arm. In making measurements it is necessary to have a tapping-key in the battery and one in the galvanometer circuit, so that these are only closed at the moment of making the test. This is a necessary precaution, for if the current be left on for an appreciable time the resistances

will be heated, and since they will generally have different temperature coefficients, a disturbance will on this account be introduced. The battery circuit should be closed before the galvanometer circuit, as, when the reverse process is employed, a throw of the needle may take place owing to the difference in the windings of the various parts of the bridge. (See p. 323.)

For measuring very high resistances the ratio 1:100 will be employed, and the resistance R, which gives a balance must be multiplied by 100 to obtain S. Similarly, for very low resistances the ratio 100 : 1 is employed, and R is divided by 100. Should an alteration of 1 ohm in R change the deflection from a few scale divisions on one side of zero to a few divisions on the other, the fraction of an ohm necessary for an exact balance may without error be calculated by proportion to the first decimal place.

Metre Bridge.—For greater precision in comparing resistances the *Metre-bridge* may be used.

The two resistances to be compared are placed at P and Q, and a point of balance upon the stretched wire is found, for which the current in the galvanometer is zero (Fig. 94).

Then $\frac{P}{Q} = \frac{R}{S} = \frac{l_1}{l_2}$, provided that the wire is uniform in cross-section and material. The wire is usually a metre long, hence the

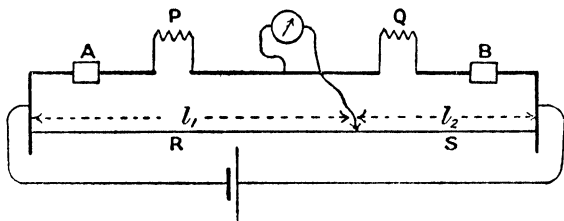

FIG. 94.

name of the bridge, and is stretched over the scale, so that the position of the point of balance may be read to within a millimetre. The connecting conductors are stout copper strips, the resistance of which is for most purposes negligible.

In the laboratory form shown in Fig. 95, P and Q are the gaps in which the resistances to be compared are placed, A and B being two additional gaps in which resistances can be placed whose function is to increase the effective length of the slide wire. For example, if the resistances at A and B are each 10 times that of the slide wire, the sensitiveness of the bridge is increased 21 times; but it should be noted that P and Q must now be nearly equal, otherwise the balancing point may not come on the slide wire.

The contact maker K rests upon three hemispherical feet, two of

which slide in the V groove running between E and F. This ensures that it shall always run exactly over the same path, and the groove being a piece of angle brass it also serves as a conductor to connect the contact maker to the battery or galvanometer, which is joined to E or F. This saves the loose running wire, which is a frequent

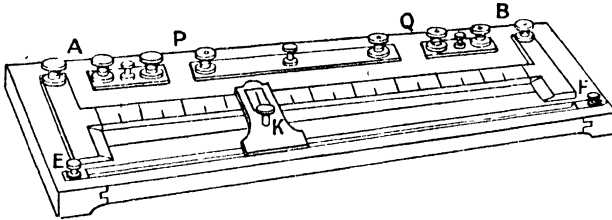

FIG. 95.

source of accident in the older patterns of metre bridge. Contact with the wire is made by pressing the ebonite-capped key, and the position of the contact with respect to the scale is determined by means of a fine scratch on the piece of glass let into the slider.

Calibration of Metre Bridge.—Unless the roughest of measurements is to be made, several unavoidable errors of the bridge must be determined. The first, results from the fact that the zero of the scale may not be actually at the effective end of the wire, owing to uncertainty in fixing the scale, and also to the fact that the copper strips and the soldering at the ends of the wire may have resistances which are not negligible.

Let the error at one end of the bridge be equivalent to a length α of the wire, and that at the other β . Two resistances of known ratio $P : Q$ are inserted, and a point of balance found at distance l_1 c.m.s. from one end.

$$\text{Then,} \quad \frac{P}{Q} = \frac{l_1 + \alpha}{100 - l_1 + \beta}$$

P and Q are now interchanged, and a new point of balance found, at say l_2 c.m.s. from the same end.

$$\text{Then,} \quad \frac{Q}{P} = \frac{l_2 + \alpha}{100 - l_2 + \beta}$$

From these two simple simultaneous equations α and β may be calculated. Of course P must not equal Q , or no change in the balance is produced on interchanging them. A convenient ratio is $P : Q :: 10 : 1$.

The second error is due to unevenness in the wire, and to correct for this, a calibration of the wire must be performed. To do this, the

wire is divided into a number of parts of equal resistance, whose lengths will, if the wire is not uniform, be different. Let them be $l_1, l_2, l_3, \dots, l_{10}$, if the number of parts chosen is 10. The mean of l_1, l_2, \dots, l_{10} is found by adding them and dividing by 10, and each one in turn is then subtracted from the mean. This gives the error over each section, and to find the resulting correction to be applied at any point, these errors must be algebraically added from one end to the point considered. By plotting a curve with lengths of wire as abscissæ and corrections at the 11 points (counting the two ends, at which the correction is, of course, zero) as ordinates, the correction for intermediate points may be found. If, then, the end corrections α and β with signs reversed be plotted upon the same diagram and the resulting two points joined by a straight line, this line may be taken as a new axis from which the total correction at any point may be measured.

There are many methods of performing the division of the wire into a number of parts having equal resistance, but the following, which makes use of a principle due to Prof. Carey-Foster, is a very convenient one.

This principle is, that if a balance be obtained with two unequal resistance at M and N (Fig. 96), and these be then interchanged and a new balance be found, the difference between the resistances M and N is equal to the resistance of the bridge wire between the two points of balance.

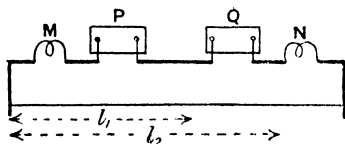

FIG. 96.

For, with M and N as shown in the figure,

$$\frac{P}{Q} = \frac{M + l_1}{N + T - l_1},$$

where l_1 is now the resistance of the length l_1 of wire and T the resistance of the whole wire. On interchanging M and N we have

$$\frac{P}{Q} = \frac{N + l_2}{M + T - l_2},$$

$$\therefore \frac{M + l_1}{N + T - l_1} = \frac{N + l_2}{M + T - l_2}.$$

Hence, adding the numerator and denominator to get a new numerator in each case,

$$\frac{M + N + T}{N + T - l_1} = \frac{M + N + T}{M + T - l_2},$$

Since the numerators are equal the denominators are also equal;

$$\therefore M - N = l_2 - l_1.$$

If $N = 0$, $M = l_2 - l_1$, and making use of this, the resistance of a length of the bridge wire may be found.

To perform our calibration, N is a thick copper strip, and M a short piece of manganin wire soldered to two stout lugs which fit the terminals, its resistance being about $\frac{1}{10}$ of that of the bridge wire. P and Q are two resistance boxes, and their resistances are varied until, with the contact maker near the end of the wire near M , say at l_1 , a balance is obtained. M and N are then interchanged and the new balance point on the wire is found, say at l_2 . Then $l_2 - l_1$ is the

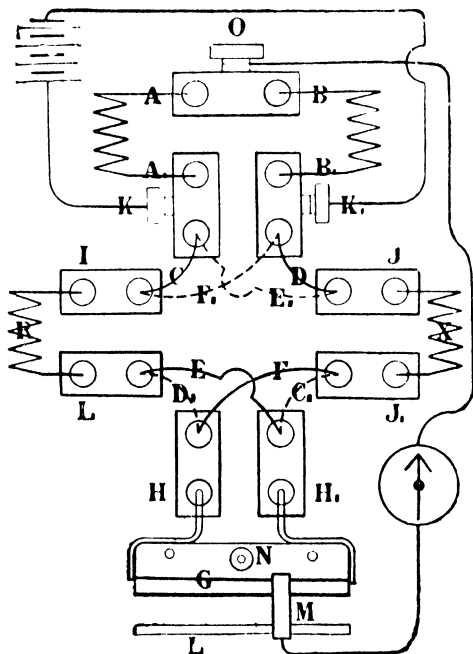

FIG. 97.

(From Henderson's "Practical Electricity and Magnetism.")

temperature. The two coils, R and X , to be compared, are placed at IL and JJ_1 , and the balancing performed upon the short wire G , which must be previously calibrated. R and X may be interchanged in position with respect to the bridge by means of the thick copper conductors $CDEF$, which, for convenience, are mounted on one ebonite block, the rotation of which through 180° executes the required interchange.

first section of the wire which has a resistance equal to M . Without moving the contact maker, M and N are placed in their first positions, and P and Q varied until a balance is nearly obtained, the fine adjustment being then made by moving the contact maker. M and N are interchanged as before, and the process repeated until the end of the bridge is reached.

For comparing two very nearly equal resistances, as in the case of two standard coils nominally of the same value, the Carey-Foster bridge of a special form may be used.

The ratio coils AA_1 and BB_1 (Fig. 97) are equal and are frequently wound on one bobbin for the convenient elimination of error due to possible difference in

Callendar and Griffiths Bridge.—This is another adaptation of the Wheatstone's bridge to a special purpose; in this case the measurement of temperature by the change in resistance of a platinum wire.

P and Q (Fig. 98) are the ratio arms which are adjusted to equality, and the platinum wire W is connected by internal leads to PP, and thence to the gap of the bridge T. An equivalent pair of leads joined together within the tube containing W,

go to the gap C, and thus the disturbing effect of the leads on account of their variation in temperature is eliminated, the two pairs being in practice kept close together, and their two resistances being always equal and introduced in opposite arms of the bridge, which is adjusted for equality. The bridge wire MN is 50 cms. long, and at 1, 2, 4, 8, 16, 32, 64, and 128 are placed resistances whose values are 1, 2, 4, etc., times the resistance of 20 centimetres of MN. Since this has a resistance of about $\frac{1}{200}$ ohm per centimetre, the resistances of 1, 2, 4, etc., are therefore 0.1, 0.2, etc., up to 12.8 ohms, and with all of them in, W may have a total resistance of 23.5 ohms. The balance is obtained by moving the cross-piece which connects the wires AB and MN, all of which are made of the same material in order to avoid thermoelectric disturbances.

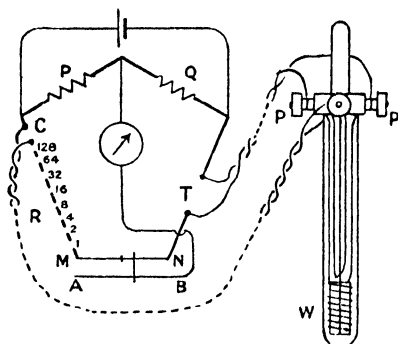

FIG. 98.

If the balance is obtained with the slider at a distance l from the middle of MN, and ρ be the resistance of a centimetre of MN, then, since the ratio arms are equal—

$$r + R + m + \rho l = r + T + m - \rho l,$$

where r is the resistance of the leads on either side, and m is the resistance of half of MN.

$$\therefore T = R + 2\rho l.$$

The change of resistance of a platinum wire between 0° C. and 100° C. when the resistance at 0° C. is 12.8 ohms, is 5 ohms, which is equivalent to 0.05 ohm for 1° change. If, then, $\rho = 0.005$, l must change by $\frac{0.05}{2 \times 0.005} = 5$ cms. to maintain a balance as the temperature rises 1°. Hence a millimetre of wire corresponds to a change of temperature of $\frac{1}{50}$ degree.

It was shown by Prof. H. L. Callendar¹ that the resistance of a pure platinum wire may be accurately represented by the relation

$$R_t = R_0(1 + at + \beta t^2)$$

over a very great range of temperature, where R_0 , a , and β are constants which may be found by measuring R_t at three different temperatures. For limited ranges, the resistance at -273°C . may be taken as zero, and those at 0°C . and 100°C . found by the usual method of finding the fixed points of a thermometer; but for extended ranges the temperatures 0°C ., 100°C ., and the boiling point of sulphur at 760 mm. of mercury pressure (444.53°C .) are employed.

Prof. Callendar has also shown that if the temperature t_p on the platinum thermometer scale be calculated from the relation

$$t_p = 100 \frac{R_t - R_0}{R_{100} - R_0}$$

where R_t , R_0 , and R_{100} are the resistances of the thermometer at t° , 0° , and 100°C . respectively, the difference $(t - t_p)$ between t_p and the temperature t on the air thermometer scale is given by the relation

$$t - t_p = \delta \left(\frac{t}{100} - 1 \right) \frac{t}{100}$$

and Griffiths has shown that if pure platinum be employed, δ has the value 1.5. Thus if a curve connecting t_p and t be plotted, the correction to be added to t_p to obtain t for any value of t_p may be read upon it.

In order that the resistance between M and N shall be exactly $\frac{1}{4}$ ohm the actual resistance of the wire is slightly greater than this, and it is shunted with a fine wire whose length is adjusted until that of the combined resistance is exactly $\frac{1}{4}$ ohm. This does not in any way alter the point of balance, and ρ is now $\frac{1}{50}$ of combined resistance between M and N.

For temperatures up to 300°C . the thermometer consists of a platinum wire wound upon a mica frame and enclosed in a glass tube, but for higher temperatures the tube must be of glazed porcelain.²

Galvanometer Resistance (Kelvin).—The determination of the resistance of a galvanometer by means of the Wheatstone's bridge was first performed by Lord Kelvin, and is generally known as the Kelvin method. We have seen on p. 71 that the current g in the galvanometer circuit (Fig. 93 i.) is zero when $\frac{P}{Q} = \frac{R}{S}$, and consequently the currents in the remaining arms are independent of r_g . The gal-

¹ H. L. Callendar, *Phil. Trans.*, 178, 1. 1887.

² For experimental details of finding the fixed points and for calibrating the bridge, the student may with advantage consult "A Text Book of Practical Physics," by W. Watson.

vanometer is therefore placed in the arm S, Fig. 99, when, on making the battery circuit, a deflection will be produced. This may be reduced to a readable amount by one of two methods: a resistance, T, may be introduced into the battery circuit which reduces the whole current in the bridge, and therefore the sensitiveness of the test, or the spot of light may be brought back on to the scale by means of the controlling magnet in the case of a suspended needle instrument, or by twisting the torsion head in the case of a suspended coil instrument. In the case of a delicate galvanometer it may be desirable to combine the two processes. The resistances in the arms are then adjusted until the spot of light is brought to rest, and will still remain at rest whether the key K be open or closed. When this condition is attained $\frac{P}{Q} = \frac{R}{S}$, and S is, in this case, the resistance of the galvanometer.

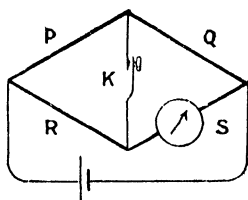

FIG. 99.

Battery Resistance (Mance).—A somewhat similar method due to *Mance* has been used for determining the resistance of a battery. The battery is placed in S, Fig. 100, and the key at K. When the key is closed a current flows in the circuit, and we may imagine this current reduced to zero by an appropriate E.M.F. in K. This additional E.M.F. would not produce any current in *g* when $\frac{P}{Q} = \frac{R}{S}$, but the current in K being zero, it is immaterial whether the key be open or closed. Therefore the condition for the resistances in the arms to be proportional is that the current in the galvanometer is unaltered by opening or closing K.

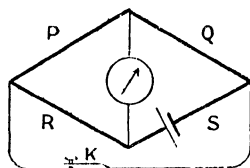

FIG. 100.

The method is not a good one, owing to the fact that the current in the galvanometer at the time of the test is large, and also that an unknown current is flowing in the battery. The resistance of the battery generally depends upon the current flowing, and this should be known, as in the method on p. 105.

Low Resistances.—The Wheatstone's bridge is unsuitable for the comparison of very low resistances, for two reasons. The first has been discussed on p. 73, and refers to the want of sensitiveness of the bridge. The other important reason is that with low resistances, the connecting wires and the contacts at the terminals have resistances which are no longer negligible, and they may even be as great as, or greater than, the resistances to be compared, unless special precautions on this account are taken.

By the method of *direct deflection*, the two low resistances may be

compared. A steady current is passed through the two conductors in series, and the galvanometer deflection produced by the p.d. between two points separated by a distance l_1 upon the first conductor, compared with the corresponding deflection for the distance l_2 upon the second

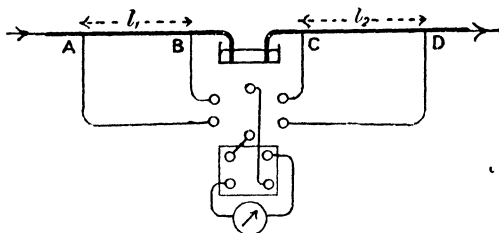

FIG. 101.

conductor. Then, if the galvanometer have a resistance which is high compared with that of the conductors under comparison (it is usually thousands of times as great), the current in the galvanometer will be inappreciable in comparison with that in the conductors. The current in the first case is proportional to E_1 , the fall of potential over l_1 , and the second to E_2 , the p.d. over l_2 . Then if R_1 and R_2 are the corresponding resistances, and θ_1 and θ_2 the deflections—

$$\text{Current} = \frac{E_1}{R_1} = \frac{E_2}{R_2}, \quad \therefore \frac{R_1}{R_2} = \frac{E_1}{E_2} = \frac{\theta_1}{\theta_2}.$$

But if S_1 and S_2 are the resistivities of the materials of the two conductors, and d_1 and d_2 their diameters, as determined by the micrometer gauge—

$$\frac{R_1}{R_2} = \frac{S_1 l_1}{d_1^2} \cdot \frac{d_2^2}{S_2 l_2} = \frac{\theta_1}{\theta_2}$$

$$\therefore \frac{S_1}{S_2} = \frac{\theta_1}{\theta_2} \cdot \frac{l_2 d_1^2}{l_1 d_2^2}$$

If it is desired to determine S_1 and S_2 in ohms for unit length and cross-section, a standard low resistance may be included in the circuit and the deflection due to the p.d. across it compared with that for the given conductors.

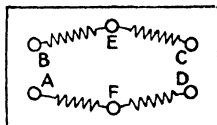

FIG. 102.

By means of the *Kelvin bridge* a more accurate comparison of two low resistances may be made, but in this case the lengths l_1 and l_2 are adjusted until the resistances are equal, or in a ratio very nearly equal to unity.

AD and BC (Fig. 102) are two resistance coils whose mid-points are at E and F, which are connected to the conductors under comparison as shown in Fig. 103. The current g

in the galvanometer is zero when $r_1 = r_3 = r_5$. Taking x for the current in r_3 , y that in r_5 , and b that in the battery, and applying Kirchhoff's first law to the currents at the point A, we have—

$$\begin{aligned} \text{Current in } r_1 &= b - y. \\ \text{Similarly current in } r_5 &= b - y - x \\ \text{,, ,, } r_4 &= x - y \\ \text{,, ,, } r_6 &= y + y \\ \text{,, ,, } r_2 &= b - y - g \end{aligned}$$

Applying Kirchhoff's second law to the mesh—

$$\begin{aligned} \text{AFD,} & \quad yr_5 + (y + g)r_6 + br_b = E \\ \text{for ABEF,} & \quad (b - y)r_1 + xr_3 + gr_g - yr_5 = 0 \\ \text{for BCE,} & \quad (b - y - x)r_5 - (x - g)r_4 - xr_3 = 0 \\ \text{for FECD,} & \quad (x - g)r_4 + (b - y - g)r_2 - (g + y)r_6 - gr_g = 0 \end{aligned}$$

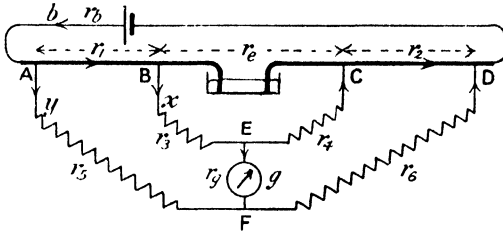

FIG. 103.

which equations simplified become—

$$\begin{aligned} r_6g + r_b b & \quad + (r_5 + r_6)y = E \\ r_g g + r_1 b & \quad + r_3 x - (r_1 + r_5)y = 0 \\ r_4 g + r_5 b - (r_1 + r_4 + r_5) x & \quad - r_1 y = 0 \\ -(r_2 + r_4 + r_6 + r_g)g + r_2 b & \quad + r_4 x - (r_2 + r_6)y = 0 \end{aligned}$$

Solving these equations for g in the form of determinants, we have for the numerator, the quantity—

$$\begin{vmatrix} E & r_b & 0 & (r_5 + r_6) \\ 0 & r_1 & r_3 & -(r_1 + r_5) \\ 0 & r_5 & -(r_1 + r_3 + r_4) & -r_1 \\ 0 & r_2 & r_4 & -(r_2 + r_6) \end{vmatrix} = E \begin{vmatrix} r_1 & r_3 & -(r_1 + r_5) \\ r_5 & -(r_1 + r_3 + r_4) & -r_1 \\ r_2 & r_4 & -(r_2 + r_6) \end{vmatrix}$$

Dropping E, this is

$$r_1 \begin{vmatrix} -(r_1 + r_3 + r_4) & -r_1 \\ r_4 & -(r_2 + r_6) \end{vmatrix} - r_3 \begin{vmatrix} r_5 & -r_1 \\ r_2 & -(r_2 + r_6) \end{vmatrix} - (r_1 + r_5) \begin{vmatrix} r_5 & -(r_1 + r_3 + r_4) \\ r_2 & r_4 \end{vmatrix}$$

which reduces to

$$(r_3 + r_4)(r_1 r_6 - r_2 r_5) + r_4(r_1 r_6 - r_2 r_5) + r_4(r_3 r_6 - r_4 r_5)$$

which is obviously zero if $\frac{r_1}{r_2} = \frac{r_3}{r_4} = \frac{r_5}{r_6}$, and therefore the current in the galvanometer is then zero.

This arrangement is known as the Kelvin bridge. When the coils BC and AD are accurately bisected at E and F, the condition for a balance is $r_1 = r_2$. The distances AB and CD (Fig. 103) are adjusted until the galvanometer deflection is zero, and then $r_1 = r_2$. If, however, the coils are not accurately bisected, the ratio of r_1 to r_2 is known when

$$\frac{r_3}{r_4} = \frac{r_5}{r_6}.$$

Having determined the lengths of the bars which have equal resistances, we may find the ratio of the resistivities as in the last method (p. 100).

The temperature of the conductors at the time of the experiment should be noted, especially if they are of different materials, since the temperature coefficients will in all probability be different for the two.

Cells.—For the purposes of electrical measurements when very small currents are required, it is convenient to use one or more ordinary voltaic cells. Those most commonly employed, when great constancy of E.M.F. is not required, are the Daniell or the Leclanché. To produce large currents the secondary or storage cell is used, while for standards of E.M.F. we have the Latimer-Clark or the Cadmium cell. These will be described in Chapter VII.

The Daniell's cell consists of a zinc electrode in dilute sulphuric acid (1 sulphuric acid to 10 of water by volume), and a copper electrode in concentrated copper sulphate solution. The solutions are separated by a porous pot of unglazed earthenware. Sometimes the outer vessel is of copper and forms the electrode. The E.M.F. of the Daniell is about 1.1 volts.

In the Leclanché cell the negative electrode is an amalgamated zinc rod, and the positive electrode a carbon rod, packed round with manganese dioxide, and situated in a porous pot. The electrolyte is a saturated solution of ammonium chloride. The E.M.F. of the cell is about 1.45 volt, but quickly drops if much current be taken; it recovers, however, if the cell be allowed to stand idle.

The *dry cell* now largely used for electric bells and telephones is of the Leclanché type, the manganese dioxide being mixed with sawdust, which contains enough moisture for the efficient action of the cell.

Comparison of Electromotive Forces.—For a simple comparison of the E.M.F.'s of cells, a substitution method, similar to that employed for the comparison of resistances, may be used (p. 90).

Two cells are in turn connected in series with a high resistance and a galvanometer. If the resistances of the cells themselves are

negligible, the currents, and therefore the deflections, are proportional to the E.M.F.'s.

Thus $\frac{E_1}{E_2} = \frac{\theta_1}{\theta_2}$, or if a tangent galvanometer be used $\frac{E_1}{E_2} = \frac{\tan \theta_1}{\tan \theta_2}$.

In order to avoid the error introduced by the resistances of the cells themselves, a *sum and difference* method is sometimes used. The cells are both together connected in series with the galvanometer, first with their E.M.F.'s acting the same way round the circuit, and then with their E.M.F.'s opposing each other. In the first case the total E.M.F. in the circuit is $E_1 + E_2$, and in the second case $E_1 - E_2$. If I_1 and I_2 are the respective currents, we have, since the resistance of the circuit is the same in both cases—

$$\frac{E_1 + E_2}{E_1 - E_2} = \frac{I_1}{I_2} = \frac{\theta_1}{\theta_2}$$

$$\therefore \frac{E_1}{E_2} = \frac{\theta_1 + \theta_2}{\theta_1 - \theta_2}$$

Potentiometer.—By far the best method of comparing electromotive forces is that due to Poggendorf, and now generally known as the *Potentiometer method*. A steady current is maintained in a conductor, and the E.M.F.'s to be compared are balanced in turn against the potential fall over a known portion of the conductor. There are many forms of the potentiometer, but the simple slide wire, two or three metres long, comprises a very simple and effective instrument. The cell C (Fig. 104), preferably of the secondary or storage form on account of its constancy of E.M.F. when producing current, maintains a current in the stretched wire AB, which may suitably be of platinoid or manganin of No. 22 gauge. One of the cells whose E.M.F.'s are to be compared, is placed at E, with one pole connected to A, and the other through the galvanometer G to a movable contact D. If the fall of potential between A and D corresponding to the current is

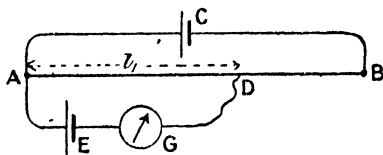

FIG. 104.

equal to the E.M.F. of the cell, there will be no current in the galvanometer, provided that the cell E is connected with its positive electrode to the end of the wire having the higher potential. When a uniform wire is used, the p.d. between two points on it is proportional to the length of wire between the points, and thus in the given case $E_1 \propto l_1$. The cell is now replaced by the second cell, and another balance obtained, at distance l_2 from A. Then $\frac{E_1}{E_2} = \frac{l_1}{l_2}$. It should be noticed that if the current in AB varies during the experiment l is no

longer proportional to E alone, and therefore it is advisable to repeat the experiment with the first cell to ensure that the current has not changed. The E.M.F. of C must, of course, be greater than that of E , otherwise there will not be a possible position of balance upon the wire. With a length of 3 metres of wire, and a secondary cell to produce the steady current, a balance may usually be obtained with certainty, to within an error of a millimetre of wire, even with a comparatively rough galvanometer, and thus for a balance near the middle of the wire the error is less than 1 in 2000. There is a further advantage in this method, in that the cell whose E.M.F. is being determined is not producing a current at the time at which the balance is produced, and hence the determination of E.M.F. is independent of the resistance of the cell. A simple and convenient form of potentiometer may be made by soldering the ends of a piece of No. 22 platinoid wire to two copper lugs, A and B (Fig. 105), the length of

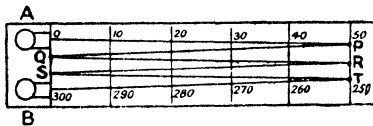

FIG. 105.

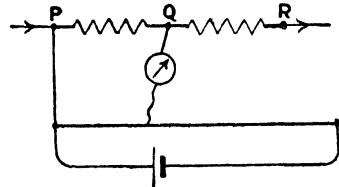

FIG. 106.

wire between the lugs being 3 metres. These lugs are screwed down to the board, the wire passing round the small screws P , Q , R , S , T . A piece of centimetre ruled squared paper having previously been pasted on, this serves as a scale for the measurement of l .

There is almost always a *zero error* of the potentiometer, chiefly due to the resistance of the lug and soldering. It may be readily found by passing a current through two resistances, PQ and QR , in series (Fig. 106), and finding the length of potentiometer wire l_1 for a balance for the p.d. between P and Q , l_2 for that between Q and R , and l_3 for that between P and R . If α be the zero error to be added to each reading, then, since p.d. between P and R equals the sum of the p.d.'s. between P and Q , Q and R —

$$l_1 + \alpha + l_2 + \alpha = l_3 + \alpha$$

$$\therefore \alpha = l_3 - l_1 - l_2$$

Measurement of Current by Potentiometer.—The potentiometer in conjunction with a standard resistance is a very convenient current measurer.

Thus, suppose it is required to calibrate the ammeter A (Fig. 107). A suitable current is passed through it, the standard resistance R being in series with it. The fall of potential over R is compared with that

of a standard cell C , which may be a Daniell's cell if rough calibration only is required, but must be a Latimer-Clark or a Cadmium cell if we desire higher accuracy. Then if l_1 be the length of potentiometer wire to produce a balance with the cell whose E.M.F. is E , and l_2 the

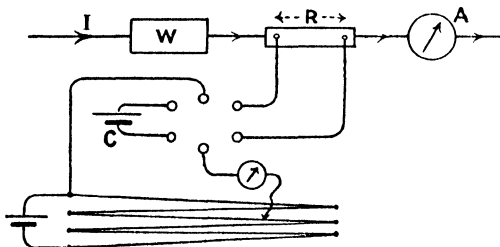

FIG. 107.

length for the p.d. over the resistance R when current I is flowing in it—

$$\text{p.d. for resistance } R = E \cdot \frac{l_2}{l_1}$$

$$\text{and, } I = \frac{E}{R} \cdot \frac{l_2}{l_1}$$

On varying the current by means of the rheostat W , and taking a number of readings for different points on the ammeter scale, a calibration curve may be constructed.

Resistance of Cell.—The potentiometer may also be used to determine the *internal resistance of a cell* by the following method. The length of potentiometer wire required to balance the E.M.F. of the cell is first found in the ordinary way. Let it be l_1 . E is the p.d. between the terminals of the cell when it is not producing any current, and is the whole E.M.F. available to produce current. If now the terminals of the cell be connected by a conductor of

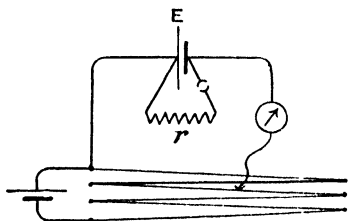

FIG. 108.

resistance r (Fig. 108), the current flowing in it will be $\frac{E}{R+r}$, where R is the resistance of the cell. Further, this current flowing in the conductor r means that a p.d. of $\frac{E}{R+r} \cdot r$ exists between the ends of the conductor, and this is proportional to l_2 , the length of

potentiometer wire which will now produce a balance. Calling this p.d. e , we have—

$$\begin{aligned} \bar{R} + r \cdot r &= e, \\ \frac{R + r}{r} &= \frac{E}{e} = \frac{l_1}{l_2}, \end{aligned}$$

from which R may be found.

It is an interesting experiment to take a cell of the Leclanché type and determine its internal resistance a number of times, using values of r equal to 100, 50, 20, 10, 5, and 1 ohms respectively. It will be seen that the resistance of the cell increases with the current in it.

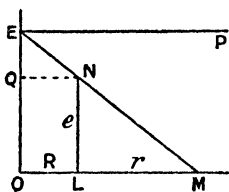

FIG. 109.

The reason for the method may be made a little plainer by drawing the E.M.F. — Resistance diagram for the circuit. Let OE (Fig. 109) be the E.M.F. of the cell; then, if the resistances of the different parts of the circuit be plotted along OM so that $OL = R$,

$LM = r$, and the last point M be joined to E,

$$\tan EMO = \frac{E}{R + r} = \text{current};$$

further, we see that so long as Ohm's law holds good, the line, such as ENM, drawn upon the E.M.F. — Resistance diagram must be a straight line, since the current is the same at each cross-section of a circuit, and is represented on the diagram by the slope of the line. When the circuit is broken, the resistance r is infinite, and the point M moves to

infinity; that is, the curve becomes the horizontal straight line EP. In the potentiometer experiment, OE is measured in the first case (l_1), and LN in the second case (l_2), and we see from the figure that—

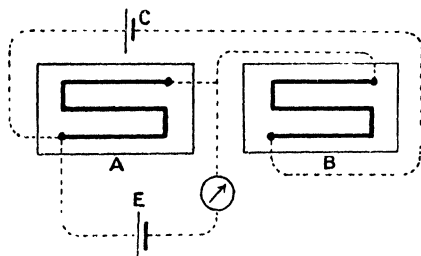

FIG. 110.

$$\frac{OE}{LN} = \frac{R + r}{r} = \frac{l_1}{l_2}.$$

Rayleigh Potentiometer.

—A potentiometer method in which two similar resistance boxes are employed in place of the stretched wire, was used by Lord Rayleigh in his work on standard cells (Fig. 110). The boxes are joined in series with a cell, to maintain steady current, and one set of plugs taken out. Any alteration in the

resistances is made by transferring plugs from one box to the corresponding resistance gap of the other box, so that the total resistance in the two boxes remains constant, and the current therefore does not change. The E.M.F. of the cell *E* is then proportional to the resistance in the box *A* when the galvanometer indicates a balance.

Crompton Potentiometer. — It will have been noticed that the smaller the current in the potentiometer wire, the greater the length of wire for a given p.d. and the more sensitive is the arrangement. For measuring very small E.M.F.'s, such as we have in the case of thermo-electromotive forces, which may be only a few millivolts, the sensitiveness may be sufficiently increased by including a resistance in the wire circuit, to reduce the current. But this decreases the range of the instrument, unless the added resistance has a value which is known in terms of the length of the potentiometer wire, in which case it may be included in the balancing part of the circuit when required. Thus if the balancing

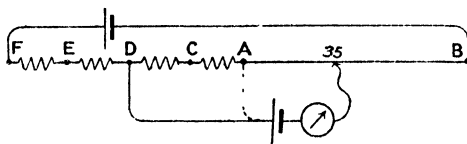

FIG. 111.

wire *AB* (Fig. 111) be 100 cms. long, and the resistances *AC*, *CD*, *DE*, and *EF* are each equal to the resistance of *AB*, then, when the balance is attained for the point, say 35, upon *AB*, this corresponds to a p.d. proportional to 35 if the other contact is at *A*; but to 235 if at *D*, and 435 if at *F*, etc. This method of increasing the sensitiveness without sacrificing the range is used in the *Crompton potentiometer*, Fig. 112. *ab* is the balance wire, and at *c* there are fourteen coils, each of which

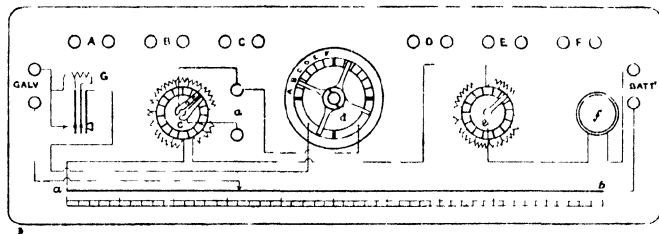

FIG. 112.

has a resistance equal to the whole of *ab*, and so arranged that the potential terminal from the source under measurement may be connected directly to *a* or to the junction between any of the fourteen coils, by means of the rotating arm. *d* is a key which enables any of the external sources of E.M.F. to be compared, these being joined

to A, B, and C, etc., to be rapidly and easily brought into action. Two adjustable resistances, e for rough and f for fine adjustment, enable the current to be varied, and if a standard Clarke cell be connected to A, the temperature being 15° C., the E.M.F. is known to be 1.4345 volts, so that the whole 14 coils at c are switched in, and the contact set at the point 34.5 upon the wire, the current may be varied by these resistances until a balance is attained. Every unit of bridge wire will then correspond to $\frac{1}{1000}$ volt, and in this way the scale has been made to give readings directly in millivolts. This adjustment having been made, any other source connected to B may be measured directly in millivolts. Since the smallest scale division is one-tenth of a unit, and a balance may be made to say half a small division, electromotive forces down to $\frac{1}{20000}$ volt may be measured.

If the electromotive force being measured be the difference of potential between the ends of a standard resistance of $\frac{1}{100}$ or $\frac{1}{1000}$ ohm carrying a current, a unit on the slide wire will correspond to 0.1 ampere or 1 ampere respectively. Hence the usefulness of the instrument in conjunction with a standard resistance for current measurement.

For measurement of large p.d.'s a volt box must be used. This is a high resistance, to the ends of which the p.d. to be measured

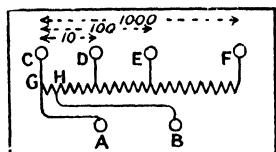

FIG. 113.

is applied, the potentiometer terminals being joined to two points of the high resistance, separated by a small resistance which is some convenient fraction of the whole. Thus in Fig. 113 the resistance between G and H is $\frac{1}{10000}$ of that between C and F, $\frac{1}{100}$ of that between C and E, and $\frac{1}{10}$ of that between C and D. If then a p.d. of say 120 volts exists between C and E, that between A and B is 1.2 volts, and on measuring this in the ordinary way by connecting A and B to the potential terminals of potentiometer, the observed value must be multiplied by 100. When C and D are used, the observed p.d. between A and B must be multiplied by 10, and when C and F are used, by 1000. Voltages less than 1.5 volts are measured directly without the aid of the volt box.

CHAPTER V

ELECTROSTATICS

Fundamental Considerations.—In the last two chapters we have repeatedly used the expression “electric current” without considering whether there is anything actually flowing along the conductor. Magnetic phenomena, which we have chiefly used for recognizing and measuring the current, are essentially of a statical nature, and so far as they alone are concerned we might have difficulty in deciding whether an electric current is a flow or a mere statical condition of the conductor. The phenomena of electrolysis and of the production of heat in a conductor both suggest that the current is of the nature of a flow, since both these effects are proportional to time, that is, they are both rates, the former being measured by a rate at which certain chemical actions take place, and the latter the rate at which heat is produced. Following, then, the suggestion that a current is a flow, that is, a rate of passage of something along the conductor, it is desirable to see whether this something which we consider to flow along the conductor is a quantity of a physical nature, or is merely a mathematical abstraction.

Consider two conductors, A and B (Fig. 114), connected to the poles of a battery. When the circuit is completed by connecting A and B by a metallic wire, a current flows, and the current may be recognised by any of the methods previously given. From these methods we have derived a system of units for measuring the current, and we have given as an explanation, that there is a difference of potential between A and B, maintained by the battery. The question now before us is,

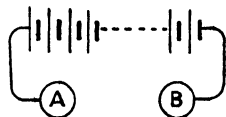

FIG. 114.

to decide whether A and B owe their difference of potential, and the current owes its existence, exclusively to the fact that A and B are connected to the battery or not. Let the connections between A and B and the battery be removed *before* A and B are connected together; then on connecting A and B a current will flow for a short time, and will rapidly fall to zero. It may be recognised by a delicate galvanometer, and will be greater, the greater the linear dimensions of A and B and the more cells there are in the battery.

But the important point is that the current flows, although there is no connection with the battery, and the act of establishing the potential difference by means of the battery is really the storing of something upon A or B or both, and the current consists in the flowing of this along the wire until the store of it is exhausted. This "something" we call Electricity.

The positive direction for the current is conventionally determined by the direction of its accompanying magnetic field, and the sign which we give to the electricity is thus a matter of convention. Thus we may say that positive electricity flows from A to B, or negative from B to A, or both; it is a matter which need not concern us now. We say that A is charged with positive and B with negative electricity in the given experiment, and that the current flows until these charges have disappeared. According to theories which have been held at different times, we may say that the current is a flow of positive electricity from points of higher to points of lower potential, or of negative electricity from points of lower to points of higher potential, or both; it is a matter of indifference so far as the representation of the results of experiments are concerned, and only need begin to concern us when we seek for an explanation of the nature of electricity.

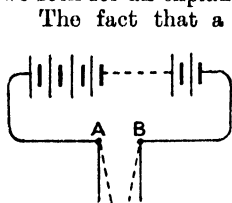

FIG. 115.

The fact that a positive charge exists upon A and will flow towards B directly a conducting path is provided for it, leads to the conclusion that there is a force driving it from A to B, and it is extremely unlikely that this force is due to the conductor; hence we naturally suppose that there is a force driving the charge residing on A towards the conductor B, whether the two are connected by a wire or not. Also, from the two-sided nature of a force, we conclude that the charge upon B is driven towards A, and we are led to seek for evidence of this force between the charges upon A and B. It becomes evident in performing the last experiment that if there is such a force it is a small one; but if A and B are made of two light mobile bodies, such as a pair of gold leaves (Fig. 115), the force between them becomes evident. In the event of a considerable number of cells being employed to test this action, it is advisable to place a sheet of mica or other badly conducting material between the gold leaves to prevent metallic contact and the consequent short circuiting of the battery when they approach each other. Or a high resistance, say 100,000 ohms, may be placed somewhere in the circuit, which will keep the current to small value.

The experiment shows us that not only are the charges upon A and B urged towards each other, but the conductors upon which the charges reside experience corresponding forces.

Electroscope.—The experiment may be varied by constructing B in the form of a metallic box—wire gauze will do—and making A of

two gold leaves hanging from the same conductor, as in Fig. 116. Each gold leaf is still urged down the grade of potential, that is towards the walls of the enclosure. Whether we say that the gold leaves are pulled apart owing to the proximity of the negative charge upon B, or repelled owing to the similar positive charges upon the leaves, is a matter of unimportance; they represent two different ways of looking at the same phenomenon. If the connections from the battery to A and B be reversed the observed result will be the same, but in this case we may say that the negative charges on the leaves are urged up the grade of potential, that is towards the walls of the enclosure, or that they are attracted by the positive charge upon the walls, or that the negative charges upon the leaves repel each other.

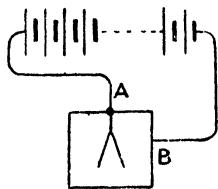

FIG. 116.

Early Electrical Experiments.—The above experiments are given in order to establish a relation between electricity in motion and electricity at rest, between the electric current and static electricity, but it must not be imagined that the evolution of the science of electricity followed any such lines. The earliest electrical experiment of which we have any record is that of the attraction of light bodies by a piece of amber that had previously been rubbed. This experiment is of unknown antiquity, but William Gilbert (1540–1603), when investigating this and other allied phenomena, introduced the word “electricity,” from the Greek word *ἤλεκτρον*, signifying “amber.” Other substances exhibit similar properties, and if, for example, a piece of ebonite be rubbed with a piece of dry fur, then on separating them they will be seen to attract each other; on bringing the ebonite near the fur the individual hairs of the latter will bend towards the ebonite. If then the ebonite be brought near the gold leaf A (Fig. 115), it will be seen to attract it, while B will be repelled by it, and the fur will attract B and repel A. We may therefore conclude that the ebonite has a negative charge and the fur is positively charged, but care must be taken in performing the experiment, or the effect will be masked by another one. On bringing the fur or the ebonite near the point A (Fig. 116) with the battery removed, the leaves will diverge, in the former case because the leaves are brought to a higher potential than the gauze box, and in the latter case to a lower potential.

About a century after Gilbert's time, it was found that all substances taken in pairs become oppositely electrified when rubbed together, but in the case of conductors, the electrification disappears as soon as the bodies are separated. If, however, a metal rod be held by an insulating handle it can easily be electrified by rubbing with fur or silk.

The arrangement of gold leaves inside a conducting enclosure is one that is very widely used for the detection of electric charges; in the earlier experiments pith balls hanging by a conducting thread from

a common point were employed. It is since the time of Cavendish that the gold-leaf electroscope has been introduced, and it is quite recently that it has been adapted to electrical measurements of an exact nature.

Faraday's Ice-pail Experiments.—By means of the electroscope, Faraday was enabled to establish several important laws of electric phenomena. He used an ice pail, which gave its name to the experiments,

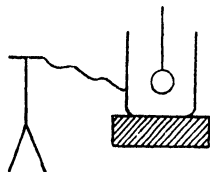

FIG. 117.

supported on an insulating stand and connected with an electroscope (Fig. 117). On lowering a charged conducting body by means of an insulating silk thread, into the ice-pail, the leaves of the electroscope diverge more and more until the charged body is well inside the pail, and then movement of the body about inside the pail produces no further change. If the charged body be removed without having touched the pail, the leaves collapse completely, but if before removal it be allowed to touch the pail on the inside, no alteration in the divergence of the leaves is produced on touching, or when the body is removed. Its charge has therefore passed completely to the outside of the pail. It is, therefore, reasonable to suppose that the divergence of the leaves depends upon the amount of charge on the body lowered into the pail, and equal charges may be compared by lowering them in turn into the pail and noting that the divergence is the same for each. Further, if equal charges of opposite kinds be obtained upon two separate bodies, that is, two charges of opposite kinds that would each produce the same divergence when used alone,

then when placed inside together, whether the bodies touch or not, there will be no divergence of the leaves, showing that the effect of adding equal and opposite charges is to produce a neutral condition.

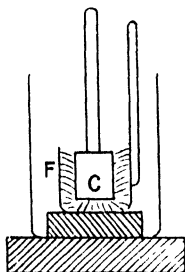

FIG. 118.

A similar experiment may be made, to show that the amounts of electricity produced in two bodies in the act of rubbing are equal, and that they are of opposite kind. An ebonite cylinder, C (Fig. 118), is made to fit loosely into a hollow cylinder, F, lined with fur, and the two are placed inside the ice-pail. If now C be given a few turns by means of the handle, there is no divergence of

the leaves of the electroscope, but on removing C the leaves diverge on account of the charge on F. On removing F and putting C in the pail, the leaves diverge to the same extent as for F, but when F and C are both in the pail together the divergence is always zero, showing that the electric charges on the two are equal and of opposite sign.

Potential Gradient due to Charge.—In the experiment, Fig. 114, the fact that a current flows from A to B when these are connected by a conductor is evidence that there is a difference of potential between them. This difference of potential accompanies the fact that

A is positively and B negatively charged, and as soon as these charges have disappeared on account of the passage of the current, the difference of potential has ceased to exist. That a charge produces a potential gradient in its neighbourhood may easily be shown by connecting two electroscopes, C and D (Fig. 119), one to either end of a conductor, AB. On bringing a positively charged body near to B a potential gradient exists, B being at a higher potential than A. Hence a current takes place in the conductor, and will flow from B to A until the accumulation of positive charge

at A and its attached electro-scope D, and the accumulation of the negative charge on B and C, restore the whole of the conductor to uniform potential, when the current ceases. If we then remove the positively charged body, we at the same time remove the potential gradient due to it, and the reverse potential gradient due to the accumulated charges

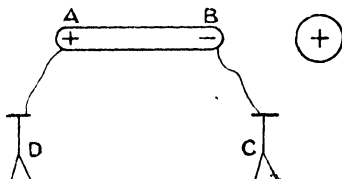

FIG. 119.

will cause a current from A to B until the potential of the conductor is again uniform. We may note here that when there is no current in a conductor there must be a uniformity of potential throughout it; in fact, the distinction between a conductor and an insulator is that a potential gradient cannot exist in a conductor without producing a current, while in an insulator a potential gradient can exist even when there is no current. The distinction resembles very much that between a fluid and a solid, the former being unable to support a shearing strain without flowing, while the latter can.

For convenience, we frequently consider the potential of the earth to be zero, and a body has then a positive potential if, when connected to earth by a conductor, a current will flow from the body to earth, and a negative potential if the current flows from earth to the body.

For this reason the gauze or metallic envelope of the electro-scope is usually connected to earth, so that the leaves have no divergence when their potential is that of earth. Then, if we bring a positively charged body A near an originally uncharged body B, the potential of B is thereby raised above that of earth, that is it is positive, and an electro-scope connected to B will show a divergence on this account (Fig. 120 (i)). If B be now connected to earth there is a positive current to earth, which flows until B's potential is zero. The leaves are now collapsed, since they are at the same potential, as in case (ii). It should

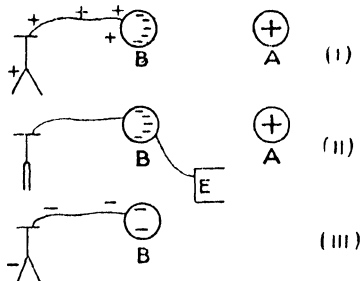

FIG. 120.

be noted that in this condition, the negative charge on B produces a negative potential at B and the electroscope, exactly equal to the positive potential due to the charge on A, point for point; in fact, a flow must occur until this condition is fulfilled. On breaking the earth connection and then removing A, the negative charge on B only is present, and will produce a negative potential (iii), the leaves of the electroscope again diverging. This process has been called "charging by induction," but the term is not a good one, as the word "induction" is used in a special sense. "Charging by influence" has also been suggested, and is not open to that objection. The process itself is a very useful one for charging a conductor, from a charge situated upon an insulator which may have been produced by rubbing, as it is more convenient than attempting to bring all parts of the insulator into contact with the conductor and has the further advantage that the original charge on the insulator is not lost.

Electrical Machines.—Apart from the frictional machine, which is extremely inefficient and cumbersome, the prototype of the electrical machine is a piece of ebonite, which may be rubbed with a piece of fur, and a metal sheet with an insulating handle, which may be lowered on to it. It is called the *electrophorus* (Fig. 121). The brass plate B is charged by influence from the rubbed ebonite plate A, as described in the last paragraph. A is frequently provided with a brass sole, S, attached to which is a brass pin, which

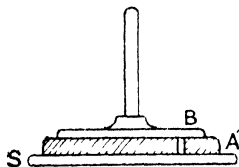

FIG. 121.

passes through A and earths B automatically, when this is lowered on to A, but the sole S is not essential to the electrophorus.

It will be seen that if a number of plates such as B, be attached to arms so that the whole can revolve, each plate moving in its own plane, coming over the plate A at some part of its path, and being discharged into a receiver at some other part of its path, an electric charge would be continually produced, so long as the rotation is maintained. This is really the principle of the *Wimshurst* machine, but instead of one conductor moving past a charged piece of ebonite, two sets of conductors corresponding to B rotate in opposite directions, the charges on one set being utilized to produce the charges on the other. Two parallel circular glass plates are mounted coaxially so that they can be driven in opposite directions, the conductors corresponding to B being metal strips cemented on to the plates. Owing to the difficulty of drawing the connections for the flat plates, these are represented in Fig. 122 as circles, and their actual appearance will be seen in Fig. 123. When the machine is running, the positively and negatively charged conductors B and B' come opposite to C and C' at the instant that the latter are connected together by two light brushes carried by a wire. Then a potential difference exists between C and C', and a current flows from C to C'. Since these were uncharged before, C will now be

negatively and C' positively charged, and the charges, moving on as the plates revolve, play a similar part in charging the outer sectors at B'' and B''' . The result of the two processes is that positively charged sectors B are continually being brought into the neighbourhood of the collector E , and C into the neighbourhood of E' , while the negatively charged sectors are brought to F and F' . From the collectors E and E' the positive charge passes to the conductor P , and from F and F' the negative charge goes to Q . The method by which the collection of the charge by E and F takes place may be noted. As the positive charge approaches E it induces charges upon E , as in the experiment described on p. 113 (Fig. 119), but the negative charge, being situated on the points nearest to the sectors, passes readily from them on to the sector and neutralises the positive charge there, the sector being thereby discharged, and a corresponding positive charge remaining upon the conducting system EP . A similar process occurs at F , but in this case it is a negative charge that remains on FQ . The action of a point in facilitating a discharge is described on p. 138.

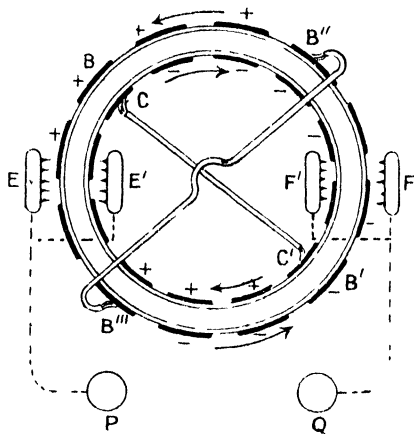

FIG. 122.

Force between Charges.—It has already been seen that charges of opposite signs tend to approach each other, and that charges of the same sign tend to travel away from each other, and although we have explained these effects in terms of existing potential differences or gradients, which method would follow naturally from the aspect of electrical phenomena adopted by Faraday, and later by Maxwell, still the phenomena may, as regards their results, be equally well explained by saying that *like charges repel each other and unlike charges attract each other*. The latter view is historically much older than the former, the earlier experimenters explaining all the electrical phenomena with which they were acquainted, in terms of the action at a distance of one charge upon another. It is chiefly to Faraday that we owe the conception that the forces upon the charges are due to some special condition of the medium in which they are situated, which condition may be a state of strain; but since we are unacquainted with the structure and nature of this universal medium, we are always driven to interpret the state of strain in terms of the forces on electrical charges. Thus the only evidence for discriminating between the two theories is that the electric phenomena require time for their propagation from

place to place ; a charge suddenly produced at a point does not produce a steady potential at every surrounding point, with the corresponding electrical field, instantaneously, but they are propagated outwards with a finite velocity. This consideration led Maxwell to calculate the velocity with which an electrical disturbance should be propagated, and the coincidence of his calculated value with that afterwards determined by experiment has completely vindicated the superiority of the "medium" over the "action at a distance" theory.

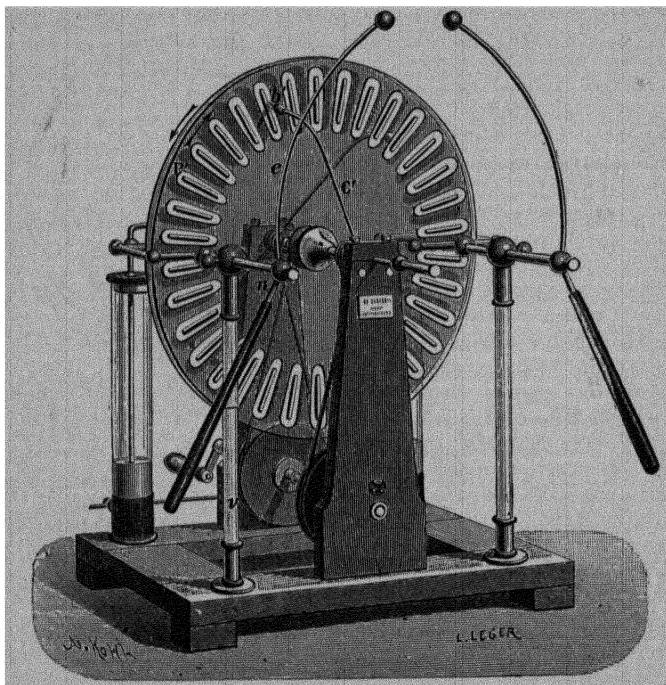

FIG. 123.

From analogy with the gravitational force between two masses, it would naturally be suggested that the force between two small electrical charges would vary inversely as the square of their distance apart. By means of his *torsion balance*, Coulomb established roughly the truth of this law. He balanced the force between the charges on two gilt pith balls, one of which was fixed, and the other on the end of a light rod suspended by a fine silver wire, against the force produced by the measured twist in the wire. On halving the distance between the balls the necessary twist in the wire was increased four times, and so on. Further, by removing the fixed ball and sharing its charge

with an equal one, the charge on the original ball, by the principle of symmetry, being supposed to be halved, and replacing the ball, it was found that the force as indicated by the torsion balance was halved. Coulomb concluded that the force between two charges may be represented by the expression $\frac{q_1 q_2}{d^2}$, where q_1 and q_2 are the magnitudes of the charges, and d their distance apart, the positive sign indicating that the force between the charges is of the nature of a repulsion.

From this relation we may define the *unit of electrical charge as that which, situated one centimetre from an equal charge in air, will repel or attract it with a force of one dyne*; and adopting this new electrostatic unit of quantity and measuring q_1 and q_2 in terms of it, we have—

$$\text{Force between charges} = \frac{q_1 q_2}{d^2} \text{ dynes.}$$

By analogy with the magnetic case (p. 3), we may define the *strength of electric field*, or *electric intensity*, or *electric force* at a point as the force in dynes, which would act on a unit positive charge if placed at that point, and we see then that the electric intensity at a distance d centimetres from a charge q is $\frac{q}{d^2}$, and that the force on any charge at a point at which the electric intensity is E , is equal to Eq .

Proof of Inverse Square Law.—The proof of the relation $F \propto \frac{q_1 q_2}{d^2}$ by means of Coulomb's torsion balance is not very satisfactory, because the charges are not situated at points, but are distributed over metallic spheres, and although this would not matter if the charges were uniformly distributed over the spheres, this condition cannot be fulfilled, since the presence of each charged sphere would disturb the distribution of charge upon the other. Also charges will be produced upon the case of the instrument, and upon all other conductors in the neighbourhood, and further, the holders of the charged balls are not perfect insulators, so that the charges will gradually leak away; and finally the amount of torsion and the distance apart of the balls cannot be measured very accurately. We have, therefore, to fall back upon indirect methods of proof, that is, to calculate certain results on the assumption of the truth of the law, and then put the results to the test of experiment.

The following proof is due to Cavendish; and at a later date Maxwell reperformed the experiment and succeeded in showing that the inverse square law is certainly very near the truth. To find the strength of electrical field at a point P (Fig. 124), situated within a charged spherical conductor, draw through P a cone having its vertex at P, and whose solid angle, $d\omega$, is very small. This cone cuts the sphere in two small areas, ds and ds_1 , which may easily be found from the distances r and r_1 of P from ds and ds_1 respectively. The area of the

right section of the cone at ds is $r^2 d\omega$, and this makes angle α with ds ,
 $\therefore ds = \frac{r^2 d\omega}{\cos \alpha}$, and similarly $ds_1 = \frac{r_1^2 d\omega}{\cos \alpha}$. If the sphere is symmetrically

situated with respect to neighbouring conductors, the charge upon it will be uniformly distributed. Let the amount of charge on each unit of area of surface be σ ; then the amount on ds is $\frac{r^2 \sigma d\omega}{\cos \alpha}$, and

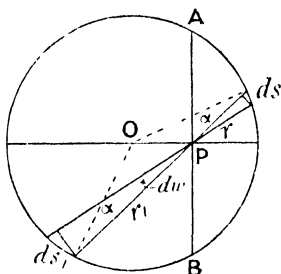

FIG. 124.

that upon ds_1 , $\frac{r_1^2 \sigma d\omega}{\cos \alpha}$. If, then, the strength of field due to a charge varies inversely as the n th power of the distance, the field at P due to the charge on ds will be $\frac{r^2 \sigma d\omega}{r^n \cos \alpha}$, and due to that on ds_1 , $\frac{r_1^2 \sigma d\omega}{r_1^n \cos \alpha}$.

These are obviously equal when $n = 2$, and since they are oppositely directed, the resultant field at P due to the charges on

ds and ds_1 is zero. The whole sphere may be divided by cones into pairs of surfaces in the same manner, and consequently the electrical intensity at P due to the whole charge on the sphere is zero.

If $n > 2$ the component of intensity due to ds is greater than that due to ds_1 , since $\frac{1}{r^{n-2}}$ will then be greater than $\frac{1}{r_1^{n-2}}$, r_1 being greater than r , and all the elements on the same side of the plane APB (Fig. 124) as ds , give rise to components at P greater than those due to the corresponding elements on the same side of the plane as ds_1 , since for all these pairs $r_1 > r$, and if the charge on the sphere be of positive electricity, there will be a resultant field towards the centre of the sphere. On the other hand, if $n < 2$ it follows in a similar manner that there will be a resultant field which will be directed outwards from the centre.

Cavendish, and at a later date Maxwell, supported a sphere, A, inside a second sphere, B (Fig. 125), so that the two are independently insulated, except when connection is made between them by the hinged wire at the top.

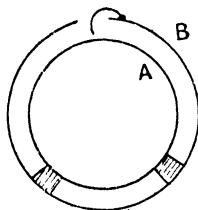

FIG. 125.

B is first positively charged; then A is connected to B by means of the wire, and the connection is then broken so that A is again insulated. From the reasoning given above, A would be positively charged if $n > 2$ and negatively charged if $n < 2$, and uncharged if $n = 2$. Cavendish, using a pith-ball electroscope, could not detect any charge upon A, and from the result of his experiment concluded

that n must certainly be within one per cent. of the value 2. Later

Faraday, with a gold leaf, failed to detect any charge within a closed conductor, and in 1870 Maxwell re-performed Cavendish's experiment, using a quadrant electrometer to detect the charge, and again failed to find any. From a measurement of the smallest charge upon A that could be detected by the electrometer, Maxwell concluded that n cannot differ from 2 by more than $\frac{1}{21000}$. There is no reason to suppose that greater accuracy in making the observation would do more than reduce the uncertainty in the amount by which n differs from 2. For all purposes, the truth of the inverse square law is taken to be established.

Dielectrics.—The variation of the force between two charges with their distance apart, does not in any way depend upon the nature of the medium in which they are situated, provided that this is uniform, but it has long been known that the medium plays an important part in determining the absolute value of the force. Thus Franklin found that it is the glass of the Leyden jar which carries the electric charges, the tinfoil merely serving to short-circuit *simultaneously* the whole of the two surfaces of the glass; and Cavendish observed that two metallic surfaces held a greater amount of charge when separated by glass than would have been expected had they been separated by air. Faraday, by means of an experiment to be described later, measured the effect of various non-conducting substances in increasing the capacity of two metallic conductors separated by it. The law of force between charges must therefore be modified in order to take into account the influence of the medium in which they are situated, and keeping to our definition of unit charge on p. 117, we say that—

$$\text{Force} = \frac{q_1 q_2}{kr^2} \text{ dynes,}$$

where k is a constant, the value of which depends upon the medium in which the charges are situated. That k is a constant quantity for each non-conducting substance can only be proved indirectly, and we shall consider this to be established if the results obtained upon this assumption are afterwards found to be in accord with observation. Faraday gave the name *specific inductive capacity* to this constant, and owing to the fact that insulators only can support an electric field, he called them dielectrics. Hence the name *dielectric constant* is now generally applied to this quantity.

According to our definition of the electrostatic unit of quantity of electricity, k should be unity for air, but since a vacuum is the best dielectric known, it would be more natural to take its constant as unity, and from this, define *the electrostatic unit of charge as that which repels an equal charge with a force of one dyne when situated one centimetre from it in vacuo*. The value of k for air at atmospheric pressure is then about 1.000590, and for hydrogen 1.000264. These numbers are so nearly equal to unity that, unless specially mentioned, we shall take k as unity for air.

Taking for the definition of electric intensity, the force on unit

positive charge placed at the point under consideration, we now see that in a dielectric whose specific inductive capacity is k , the electric intensity due to a single charge is $\frac{q}{kr^2}$, and for any distribution of charges

the intensity is $\frac{1}{k}$ of that when the medium is air, or rather vacuum.

Potential.—In the case of a magnetic field we saw on p. 13 that there are two ways of representing it, one in terms of the force on unit pole, or the magnetic force at every point, and the other in terms of potential; so likewise in the electrical case the force upon unit charge at every point gives us a complete representation of the field, and we must now see how far the idea of potential will assist us.

Potential is a quantity whose rate of variation in any direction is the electric intensity or force in that direction.

Thus $E = -\frac{dV}{dx}$, where V is electric potential. This may also be written in the form—

$$dV = -Edx.$$

Edx is the amount of work done, when a unit charge is moved through the infinitesimal distance dx . Hence if the unit charge be carried from a point a to a point b along a path whose direction everywhere coincides with that of E , the total work done is

$$-\int_a^b Edx$$

But,

$$\int_a^b dV = -\int_a^b Edx$$

that is, $V_b - V_a =$ work done in carrying unit charge from a to b .

We may, if we choose, define potential from this relation as a quantity the difference in whose values at two points is the amount of work which must be done in carrying a unit charge from one point to the other.

The signs are so chosen that a positive field is directed away from a positive charge, points nearer to it being at higher potential than those further away. Hence from the last relation we see that work is to be considered as negative when the charge is moving down the grade of potential, and therefore positive when up the grade of potential. Thus work is to be considered to be positive when it is done upon the charge by any external agency.

It is immaterial what path is followed by the charge in passing from a to b . The component of E along the path at a point such as P is $E \cos \theta$, and the work done for the element dl measured along the path is $E \cos \theta \cdot dl$.

Also, $\frac{dV}{dl} = -E \cos \theta$, or, $dV = -E \cos \theta \cdot dl$

$$V_a - V_b = \int_a^b E \cos \theta \cdot dl.$$

The work done in passing along the path aPb (Fig. 126) is equal to that in traversing aQb , for if it were not there would be a balance of work done in describing the cyclical path $aPbQa$, so that a would have more than one potential. In purely electrostatic phenomena there is only one value of the potential at each point, and the truth of our proposition depends upon this fact, although it is by no means true for all possible cases; in fact, we shall see later that the integral $\int F \cos \theta \cdot dl$ for a closed path, which we call the line integral of the field F round the circuit, measures in some cases the flux of some quantity through the plane of the circuit. In these cases, however, the phenomenon is not purely statical. It will be discussed more fully in Chapter IX. (see p. 230).



FIG. 126.

The definition of potential given above is consistent with that for potential difference on p. 59. For the current being the amount of electricity which passes through a given section of the conductor per second—

$$i = \frac{q}{t} \quad \text{or,} \quad q = it.$$

Hence the work done by the current in the section of the conductor between the points a and b for a charge q to pass, is—

$$q(V_a - V_b) = i(V_a - V_b)t.$$

Thus the work done per second is $i(V_a - V_b)$, that is, the product of current and p.d. It must be remembered, however, that different units of quantity of electricity are used in the two problems. For convenience in studying electrostatic effects, the electrostatic unit of quantity defined on p. 119, which is derived from the force between charges, is employed, while that which is derived from the force between magnetic poles, by way of the magnetic field, and electric current is called the electromagnetic unit of charge. The relation between the two units is a very important one, and will be discussed in Chapter XIII.

The *potential due to a charge* $+q$ measured in electrostatic units, follows from our knowledge of the electric intensity due to $+q$.

Thus, if a , x , and b are the distances of these points from $+q$ (Fig. 127), then at x —

$$E = \frac{q}{x^2}, \quad \frac{dV}{dx} = -\frac{q}{x^2} \quad \begin{array}{c} \bullet \\ +q \end{array} \quad \begin{array}{c} \bullet \\ a \end{array} \quad \begin{array}{c} \bullet \\ x \end{array} \quad \begin{array}{c} \bullet \\ b \end{array}$$

$$dV = -\frac{q}{x^2} dx.$$

FIG. 127.

Thus the work done in carrying unit positive charge from b to a in opposition to the force due to q is the excess in potential at a over that at b , and thus,

$$V_a - V_b = -q \int_b^a \frac{dx}{x^2} = q \left[\frac{1}{x} \right]_b^a = \frac{q}{a} - \frac{q}{b}.$$

If the unit charge were carried from a to b instead of from b to a , work would be done by the field upon the charge, and $V_a - V_b$ would be negative. Thus a has a higher potential than b in accordance with our convention (p. 120).

Potential is only measurable by its differences, and therefore there is no absolute zero of potential. It is convenient, however, to consider all points at infinity to be at zero potential, since the field at an infinite distance from our electric charges is zero. Thus if the point b be situated at infinity, $\frac{1}{b} = 0$ and potential at a is $\frac{q}{a}$.

Equipotential Surfaces.—An *equipotential surface* is one drawn through a system of points which are at the same potential. In Fig. 128 the equipotential surfaces due to a charge $+20$ units are spheres which appear in section as circles in the diagram. Those due to the

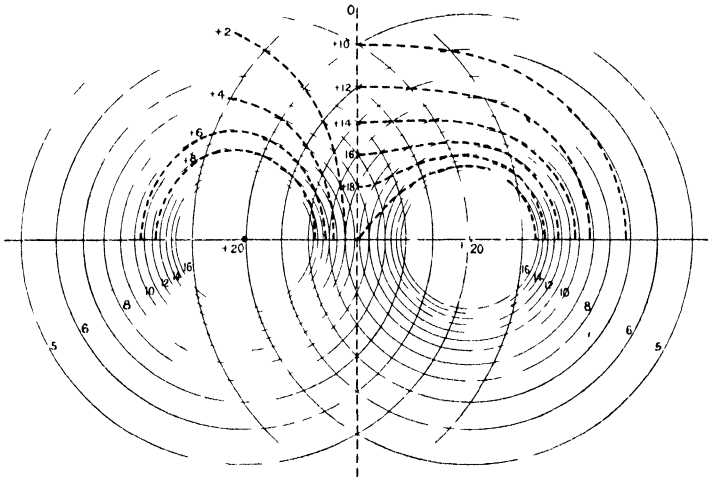

FIG. 128.

second charge of 20 units are also shown, and in the left-hand upper half of the figure the resultant equipotential surfaces are shown as dotted lines, for the case in which this second charge is negative. The potential at any point is the algebraic sum of the potentials due to the two charges. In the right-hand upper part the equipotential surfaces are drawn for the case in which both charges are positive.

The electric intensity at any point is at right angles to the equipotential surface passing through the point, for if this were not the case, it would have a component along the surface, which is only another way of saying that the potential varies as we pass from point to point along the surface. The surface would then not be one of

equipotential. Thus if the equipotential surfaces for a given field be known, the direction of the intensity at every point may be found by drawing a system of lines that cut the equipotential surfaces everywhere at right angles. Lines drawn in this way would be curves of a similar shape to those in Fig. 9 (i) when the charges have opposite signs, and to those in Fig. 9 (ii) when both charges have the same sign.

The surface of a conductor upon which any charges which may be present are at rest, is necessarily an equipotential surface, since if this were not the case there would be an electric intensity other than zero directed along the surface, in which case a current would flow. It follows that in any electrostatic problem we may imagine a conducting surface to coincide with any equipotential surface, on giving it the requisite potential, without in any way changing the conditions of the problem. This device is often of great convenience, as we shall see later.

Energy of Charge.—The process of placing a charge upon a conductor necessitates the expenditure of a certain amount of energy, which may be derived from a variety of sources. In charging a body by friction, equal amounts of positive and negative electricity are in contact until the bodies on which they reside are separated, and the action of separation requires a mechanical force to overcome the attraction between the charges. Similarly, work must be done in removing the charged metal plate from the oppositely charged ebonite sheet of the electrophorus; and the plates of the Wimshurst machine require the expenditure of work in turning them in opposition to the attraction between the oppositely charged conductors B and C (Fig. 122.) The work done is stored up as potential energy upon the charged body, and supplies the energy necessary to drive the current when the conductor is discharged.

The energy possessed by the body on account of the charge residing upon it, may be expressed in terms of the amount of charge and the potential of the body. Thus if v is the potential of the body, this represents the amount of work necessary to bring a unit charge from a point at zero potential and place it on the body; so that, to add the infinitesimal charge dq , the work necessary is $v dq$. But we have seen that at every point in the neighbourhood of a charge, the potential due to it is proportional to the charge;

$$\begin{aligned} \therefore v &= aq, \text{ where } a \text{ is some constant,} \\ \text{and work for increase of charge } dq, &\text{ is } aq dq \\ \therefore \text{work for finite charge } Q \text{ is, } &\int_0^Q aq dq = \frac{1}{2} aQ^2. \end{aligned}$$

But the potential for charge Q is,— $aQ = \text{say } V,$

$$\therefore \text{energy} = \frac{1}{2} QV.$$

If the body be discharged by a conductor, the heat produced in

the conductor is therefore $\frac{1}{2}QV$, provided that none of it is used in producing chemical action, light, or sound, etc.

If the charge be brought from a place whose potential is not zero, but say A , the energy of the charge is originally $\frac{1}{2}QA$, but when situated upon the conductor which has a potential higher than A by the amount V , the energy is $\frac{1}{2}Q(A + V)$. The difference $\frac{1}{2}QV$ is then the work done upon the charge Q in passing from one place to another, when the difference of potential between the two is V , and this amount of work can be obtained by allowing the charge to pass in the reverse direction.

The inverse of the quantity a , we shall see in the next chapter, is called the *capacity of the conductor*, and the energy of the charge may be expressed in terms of it. Thus if $C = \frac{1}{a}$,

$$\text{Energy of charge} = \frac{1}{2} \frac{Q^2}{C},$$

or since $Q = CV$,

$$\text{Energy} = \frac{1}{2}QV = \frac{1}{2}CV^2.$$

Loss of Energy on Sharing Charge.—We can see that when charge passes from a place of higher to one of lower potential, electrical energy is always lost.

For let the conductor of capacity C_1 at potential V_1 be connected to another of capacity C_2 at potential V_2 . Then if $V_1 > V_2$, charge passes from the first conductor to the second until the two come to the common potential V .

If q be the charge which passes from the first conductor to the second,

$$q = (V_1 - V)C_1 = (V - V_2)C_2$$

$$\therefore V = \frac{C_1 V_1 + C_2 V_2}{C_1 + C_2}.$$

$$\text{Energy at start} = \frac{1}{2}C_1 V_1^2 + \frac{1}{2}C_2 V_2^2,$$

and energy after the charge q has passed from one to the other

$$= \frac{1}{2}(C_1 + C_2) \left(\frac{C_1 V_1 + C_2 V_2}{C_1 + C_2} \right)^2$$

$$= \frac{1}{2} \frac{(C_1 V_1 + C_2 V_2)^2}{C_1 + C_2}$$

\therefore diminution of electrical energy

$$= \frac{1}{2}C_1 V_1^2 + \frac{1}{2}C_2 V_2^2 - \frac{1}{2} \frac{(C_1 V_1 + C_2 V_2)^2}{C_1 + C_2}$$

$$= \frac{1}{2} \frac{C_1 C_2 (V_1 - V_2)^2}{C_1 + C_2}$$

This quantity is essentially positive, whatever the signs of ∇_1 and ∇_2 , and therefore the electrical energy always diminishes when charge flows from one conductor to another. The loss appears as heat in the connecting conductor, or in the spark if the discharge takes place through air.

Theorem of Gauss.—Since an electric charge is surrounded by an electric field whose intensity has a definite value at every point, we should expect that a knowledge of the intensity at every point of a closed surface surrounding the charge, would enable us to determine the charge; just as in the case of the uniform extrusion of a fluid from a point source situated within the fluid, we can calculate the rate of extrusion by finding the total volume of liquid which crosses a closed surface, surrounding the point, in unit time. In fact the two problems are mathematically very similar, the solution for the case of an incompressible fluid being of the same form as that for an electric field.

In the electrical problem, the quantity to be evaluated for the whole closed surface is called the normal induction, and we shall define it as the surface integral of the quantity $k \cdot E \cos \theta \cdot ds$ over the whole surface. If E is the electrical intensity at a point P of the surface (Fig. 129), due to the change $+q$, $E = \frac{q}{kr^2}$, and $E \cos \theta$, the component perpendicular to the surface is

$\frac{q}{kr^2} \cos \theta$. Hence the normal induction contributed by the surface ds in the immediate neighbourhood of P is

$$k \cdot \frac{q}{kr^2} \cdot \cos \theta \cdot ds = \frac{q}{r^2} \cdot \cos \theta \cdot ds.$$

But $\frac{ds \cdot \cos \theta}{r^2}$ is the solid angle subtended at q by the surface ds , and calling this $d\omega$, we have—

$$\begin{aligned} \text{Normal induction for element } ds &= qd\omega; \\ \therefore \text{total normal induction for whole} &\left\{ \begin{aligned} &= \int qd\omega \\ &= 4\pi q \end{aligned} \right. \\ \text{closed surface} & \end{aligned}$$

since q is constant, and the solid angle $\int d\omega$ subtended by the whole closed surface is 4π .

If there be more charges than one within the surface, each charge q contributes an amount $4\pi q$ to the normal induction over the whole surface, and if q is positive it is directed outwards, if negative, inwards, so that Gauss's theorem may be stated—

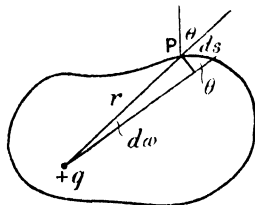

FIG. 129.

The total normal induction over a closed surface is 4π times the total amount of charge within the surface ($\Sigma 4\pi q$).

If there is no resultant charge within the surface, $\Sigma 4\pi q = 0$, and therefore the total normal induction over it is zero, and *vice versa*.

We can easily see that if a charge be situated outside the surface,



FIG. 130.

it does not contribute anything to the total normal induction over the surface. For at P (Fig. 130) the normal induction for an element of surface is $-qdw$, the negative sign being taken when the intensity is directed inwards, and

at Q it is $+qdw$, the direction being outwards, so that these two elements together would give a resultant of zero for the normal induction. Similarly for any other cone drawn through q to cut the surface, and the total normal induction is therefore zero.

If the dielectric constant be everywhere unity, Gauss's theorem states that the surface integral of E , the electric intensity over a closed surface, is equal to 4π times the charge within the surface, since in this case the surface integral of E is the total normal induction.

Electric Intensity near Charged Sphere.—Many useful problems may be very simply solved by applying Gauss's theorem. Thus the electric intensity at a point D near a uniformly charged sphere may be found by choosing our closed surface to be a sphere, concentric with the charged sphere and passing through D (Fig. 131). The area is

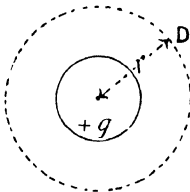

FIG. 131.

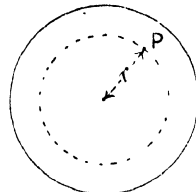

FIG. 132.

$4\pi r^2$, and by symmetry, the electric intensity is the same at every point of the sphere. Let it be E , then total normal induction is $4\pi r^2 kE$, and by Gauss's theorem it is also $4\pi q$;

$$\therefore E = \frac{q}{kr^2}$$

that is, the strength of field at D is the same as though the charge q were all at the centre of the charged sphere.

The intensity inside a sphere throughout which there is a uniform density of charge of ρ units per unit volume at once follows, for the

sphere may be divided up into thin concentric shells, and the effect of each shell which does not enclose P, the point at which the intensity is required, may be found by imagining the charge within it to be concentrated at the centre. The shells which enclose P do not add to the intensity at P (Fig. 132), as was seen on p. 118. The whole charge upon the shells which do not enclose P is equal to $\frac{4}{3}\pi r^3\rho$. And the intensity at P is therefore

$$\frac{4}{3} \cdot \frac{\pi r^3 \rho}{kr^2} = \frac{4}{3} \cdot \frac{\pi r \rho}{k}$$

The intensity is therefore greatest at the surface of the sphere, and falls off to zero at the centre.

Electric Intensity near Charged Cylinder.—In a similar manner the value of E due to an infinite cylinder which has a charge of q per centimetre length may be determined. We can see by symmetry that the field is everywhere radial and equal at equal distances from the axis. Hence, draw a coaxial cylinder through P (Fig. 133), and terminate it by two planes, unit distance apart, normal to the axis. E is parallel to these planes, and the normal induction over them is therefore zero. The area of the curved surface of the closed cylinder is $2\pi r$, and the total normal induction over the closed figure is therefore $2\pi r k E$. But the charge within it is q ; therefore, by Gauss's theorem—

$$2\pi r k E = 4\pi q$$

and,

$$E = \frac{2q}{kr}$$

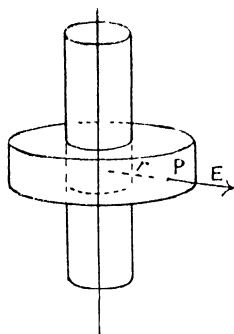

FIG. 133.

Since this is independent of the radius of the charged cylinder it holds also for a linear charge.

Intensity near Plane Sheet of Charge.

—The value of E near an infinite plane sheet, having a charge of surface density σ_0 units per square centimetre, may be found by drawing a prism whose edges are normal to the plane, to cut the surface in unit area. If the plane is infinite in extent, we see by symmetry that the field is everywhere normal to the plane, and is of the same strength on each side of it. The charge within the prism is σ_0 , and therefore the total normal induction over it is $4\pi\sigma_0$.

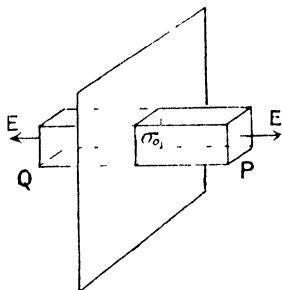

FIG. 134.

The normal induction over the sides of the prism is zero, since they

are everywhere parallel to E , and if the ends P and Q (Fig. 134), be planes parallel to the sheet, the area of each is unity, and they are both normal to E .

then, total normal induction = $2kE = 4\pi\sigma_0$

$$\therefore E = \frac{2\pi\sigma_0}{k}.$$

It will be noticed that this is independent of the distance from the sheet, and the electric intensity at any point near an infinite plane sheet is therefore $\frac{2\pi\sigma_0}{k}$; and further, that the charge is not situated upon a conductor, but is merely a sheet of charge with dielectric on both sides of it.

The electric intensity in the neighbourhood of a thin *charged plane conducting sheet* may be found from the last result by considering σ_0 to be the surface density of charge on both sides taken together. If these two happen to be equal, which in practice is unlikely to be the case, the surface density upon each side is $\frac{\sigma_0}{2}$. Calling this σ , we see that the intensity near

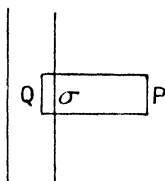

FIG. 135.

a plane conductor on each surface of which the density of the charge is σ is equal to $4\pi\sigma$. It is, however, more satisfactory to establish this relation by drawing one of the closed ends Q of the prism, within the conductor, as in Fig. 135. Then the normal induction over Q is zero, since there is no electric intensity inside a conductor when the charges are at rest upon it. The whole induction $4\pi\sigma$ passes through P , and since this has unit area,

$$kE = 4\pi\sigma, \text{ or } E = \frac{4\pi\sigma}{k}.$$

This is known as Coulomb's law.

Region inside a Conducting Surface.—We may also prove from Gauss's theorem that the *space within a closed equipotential surface is at uniform potential* when there is no electric charge within the surface.

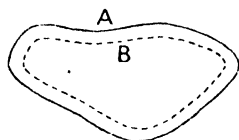

FIG. 136.

For let A (Fig. 136) be the equipotential surface; then if the space within A is not at the potential of A , a second equipotential surface B can be drawn just inside A . The potential of B is either above or below that of A . If above, there is a field everywhere directed from B to A over the surfaces, and if below, this field is directed from A to B .

In either case $\int kE ds$ is equal to 4π times the charge within the surfaces, and since by hypothesis there is no such charge, $\int kE ds = 0$. But since in either case E has the same sign all

over the surfaces, E must be zero at all points of the surface. That is, B is at the same potential as A . The same argument applies to the whole of the space within A , which is therefore at uniform potential, and there is no field within A .

It also follows that *there cannot be any charge on the inner surface of a hollow conductor* unless there be a charge in the hollow space within the conductor, and *if there be such a charge in the hollow space there will be an equal and opposite charge upon the inner surface of the closed conductor*. Consider B to be the inner surface of the conductor of which A is the outer surface (Fig. 136). Imagine a closed surface to be drawn between A and B and surrounding B . The intensity over this surface is everywhere zero, since the surface lies entirely in the conducting medium, and, by Gauss's theorem, the total charge within it is therefore zero. Hence, if there is any charge within B there must be an equal and opposite charge upon B , which establishes the second part of our proposition.

When there is no charge in the space within B there might still conceivably be equal and opposite charges upon different parts of B . Let a closed curve be drawn upon any part of B which may be supposed to have a charge upon it, and draw a closed surface to intersect B in this curve. The part of this closed surface within the conducting medium has no normal induction across it, for E is everywhere zero within the medium, and the part in the space within B has also no induction over it, as we have just seen, since E is zero within it. Hence the charge within our closed surface is zero, and that on the small area of B considered is also zero. That is, there is no charge at any point of B .

This proposition and the preceding one make general the problem proved on p. 118 for the sphere—that there is no field inside a conductor due to a charge outside it. It is also of importance in practice, for we see that a closed conductor constitutes a perfect electric screen for points inside it. Whatever the distribution of electric charge or intensity outside it, the conductor, since it is an equipotential surface, reduces the intensity inside it to zero.

Tubes of Induction and Lines of Force.—The important part played by the dielectric in electrical phenomena, led Faraday to imagine tubes or lines of strain to exist in the medium situated between charged conductors, the positive charge upon one conductor and the negative charge upon the other being merely the ends of these tubes or lines. Maxwell gave these tubes a quantitative significance, and showed that the forces between the charges could be correctly represented by assuming the tubes to be under a tension equal to $\frac{kE^2}{8\pi}$ in the direction

of the tubes, and a pressure $\frac{kE^2}{8\pi}$ normal to them, and showed that such a system of tensions and pressures in a medium would be in equilibrium. Thus, the tubes tending to shorten, owing to this tension,

would pull the opposite charges together, and the pressure of the tubes upon each other at right angles to their direction would push like charges apart (see Fig. 9).

Consider a small area S_1 (Fig. 137) drawn in an electric field with its plane at right angles to the direction of the field, and through its boundary let lines be drawn whose direction shall everywhere be that of the field. These lines enclose a tube, and if a second area S_2 be drawn anywhere at right angles to the field, it follows from Gauss's theorem, since there is no induction over the side of the tube, it being everywhere parallel to the field, that the induction over S_1 is equal to that over S_2 .

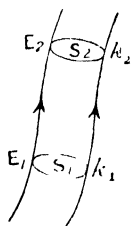

FIG. 137.

Thus $k_1 E_1 S_1 = k_2 E_2 S_2$, provided that there is no charge in the element of space situated between S_1 and S_2 , and so the normal induction over any section of the tube is a constant quantity. Calling the normal induction per unit area N , we have $kE = N$, and $N_1 S_1 = N_2 S_2$.

If the tube be traced back to the charged conductor upon which it arises, we can, by applying Gauss's theorem, as in proving Coulomb's law (Fig. 135), show that $4\pi(\sigma S) = NS$, where σ is the surface density of the charge upon the conductor, and σS is therefore the charge upon which the tube arises. If this is a unit charge, the tube is said to be a unit or Faraday tube, and we see that the number of Faraday tubes is numerically equal to the charge upon which they arise, each unit of charge giving rise to one tube. Thus with a surface density of charge σ there are σ Faraday tubes arising upon each square centimetre of surface. Calling D the number of Faraday tubes per square centimetre, we see from the last equation that—

$$4\pi D = N = kE$$

$$\therefore D = \frac{kE}{4\pi}$$

D is called by Maxwell the electric displacement in the medium, by which he means, the amount of electricity which is caused to cross each unit of area of the dielectric on account of the electric intensity at that point. Thus, if there is an electric intensity (which Maxwell calls an electromotive force) acting in a conductor, the charge continually moves on account of it; but in a dielectric this motion is not indefinite; the displacement reaches a limiting amount which is proportional to the force producing it. Thus the displacement and intensity are related to each other in the electrical case, like the strain and stress in the case of elasticity. Since a tube of induction starts upon a positive and ends upon a negative charge, the positive charge may be looked upon as a displacement in one direction at one end of the tube, and a negative charge as a displacement in the opposite direction at the other end of the tube, and throughout the tube, the displacement is continuous, but its value changes with the area of cross-section of

the tube. The more general name of polarization has also been used for this quantity, as it is of a more general character than "displacement," and the analogy with the case of magnetism is more directly suggested.

From the relation $N_1S_1 = N_2S_2$, or $D_1S_1 = D_2S_2$, we see that for a given tube of induction, the number of Faraday tubes per unit area is inversely as the cross-section of the tube; also, since $E = \frac{4\pi D}{k}$, we see that so long as k is constant at all parts of the medium E is proportional to D , i.e. to the number of Faraday tubes per unit area. If, then, instead of representing the field by tubes, we draw a line down the middle of each tube, the number of such lines per square centimetre is equal to D . It is more usual, however, to draw 4π lines for every Faraday tube, and the number per unit area is then equal to N . These are called lines of induction. If, further, $k = 1$, the number of lines per square centimetre is equal to the strength of field E . Such lines are called lines of force. This conception of lines of force and lines of induction is a very useful one for the graphical representation of fields of force, and is used very frequently in the case of magnetic as well as electrical problems.

Energy in Medium.—From the analogy with problems in elasticity, we should expect that in a dielectric there is an amount of energy per unit volume, corresponding to the quantity $\frac{1}{2}(\text{stress} \times \text{strain})$. Consider an element of a tube of induction whose length dl is so small that the electric intensity, and therefore the area of cross-section, may be considered to be constant. SS , being at right angles to E , are equipotential surfaces (Fig. 138), and therefore if we arrange two conducting surfaces, one to coincide with each, and each having the appropriate potential, we shall not alter the problem with respect to the space between them (see p. 123). Upon one of these there will be a surface density of charge $+\sigma$ and upon the other $-\sigma$, and $E = \frac{4\pi\sigma}{k}$, the charges at the ends of the tubes being $+\sigma S$ and $-\sigma S$ respectively. The force upon unit charge is E , and hence work done in carrying unit charge from one end to the other is $E dl$, which is therefore the difference of potential V between them (see p. 120). But energy = $\frac{1}{2} QV$, and Q in this case is σS ;

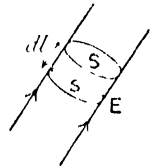

FIG. 138.

$$\begin{aligned} \therefore \text{energy} &= \frac{1}{2} \cdot \sigma S \cdot E \cdot dl \\ &= \frac{1}{2} \cdot \frac{kE^2}{4\pi} \cdot S dl = \frac{kE^2}{8\pi} S \cdot dl. \end{aligned}$$

$S dl$ is the volume of the element, and therefore the energy per unit volume is $\frac{kE^2}{8\pi}$,

or since,

$$E = \frac{4\pi D}{k},$$

$$\text{energy per unit volume} = \frac{2\pi D^2}{k} = \frac{1}{2}ED.$$

Thus, if E is of the nature of a stress, D is the corresponding strain.

It may be noted that in calculating the energy, the charge at one end only of the tube is used. This is in accordance with our procedure in calculating the energy $\frac{1}{2}QV$ for a given charge Q (p. 123). For Q is the charge placed on the given conductor, and although there must be an equal and opposite charge at the other end of the tubes of induction arising upon Q , we did not take this opposite charge into the term Q used in calculating the energy.

Force on Surface of Charged Conductor.—The expression for the energy in the medium might have been obtained by first calculating

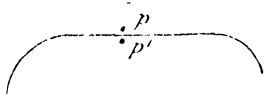

FIG. 139.

the outward force per unit area acting normally upon a charged conducting surface, and then imagining the surface displaced through a small distance. Let p be a point very close to a conductor upon which the surface density of charge is σ (Fig. 139). The electric intensity E may be

considered to consist of two parts, f due to the charge situated in the neighbourhood of p , and f' due to all other charges. Then $f + f' = E$. At the point p' , inside the conductor and indefinitely close to p , f' is the same as at p , but f is reversed in sign since p' is situated on the opposite side of the neighbouring charges to p , which charges are of course on the surface of the conductor. The resultant intensity is therefore $f' - f$. But this is zero, since p' is inside the conductor,

$$\therefore f = f' = \frac{E}{2}, \text{ a result originally due to Laplace.}$$

Now, the charge σ upon unit surface is situated in the field $f' = \frac{E}{2}$,

and the force on it is therefore $\frac{\sigma E}{2}$.

$$\text{But, } E = \frac{4\pi\sigma}{k},$$

$$\therefore \text{force per unit area of surface} = \frac{2\pi\sigma^2}{k} = \frac{kE^2}{8\pi}.$$

If, then, the surface be displaced in the direction of its normal, through distance dl , work done per unit area of surface = $\frac{kE^2}{8\pi}dl$; but the volume swept out by unit area is dl , therefore work done in

producing unit volume of electric field is $\frac{kF^2}{8\pi}$, which is therefore the energy associated with unit volume of the dielectric.

This outward pressure due to the electrification of a surface may be demonstrated by charging a soap-bubble. The tube upon which the bubble is blown is held in a block of paraffin wax, for the purpose of insulating it. On giving the bubble a charge by means of an electrophorus, the outward pressure will cause an increase in size. On giving the bubble successive small charges by bringing the charged conductor near to the glass tube, small increases in size of the bubble will be seen, but owing to the want of symmetry in the field, the bubble soon loses its spherical shape, and will eventually be driven off the tube.

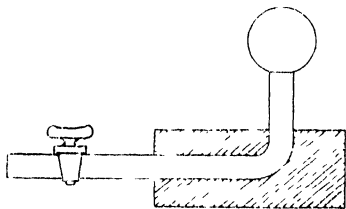

FIG. 140.

Sir J. J. Thomson has used this outward pressure to explain the fact that minute corpuscular charges of electricity will enable condensation to start in a supersaturated vapour, owing to its direction being opposite to the inward pressure due to surface tension, as the drops are forming. This will be more fully discussed in Chapter XV.

Stresses in Tubes of Induction.—On the assumption that electrostatic phenomena are due to stresses in the medium, we should expect, from the fact that there is a pull upon a charged conductor equal to a tension of $\frac{2\pi D^2}{k}$, that this pull is due to tension in the tube itself, and it follows that if the tubes are in a state of tension, they must also exert a lateral pressure upon neighbouring tubes, since if this were not the case, the tubes passing from a small positive charge to a similar negative one, would shrink until they became straight lines joining the charges, and the rest of the medium would be entirely free from them. As this is not the case, we must assume that they exert a lateral pressure upon each other, and we will now find the value of this pressure which is necessary to produce equilibrium with the tension in the tubes.

Consider a small section of a tube of induction, the sides AE , BF , CG , and DH (Fig. 141) being parallel to the field, and the ends $ABCD$ and $EFGH$ equipotential surfaces. The forces f_1 and f_2 on the faces $ABCD$ and $EFGH$ are due to the tensions $\frac{2\pi D_1^2}{k}$ and $\frac{2\pi D_2^2}{k}$ at the respective faces.

Then,
$$f_1 = \frac{2\pi D_1^2}{k} \cdot a_1$$

and
$$f_2 = \frac{2\pi D_2^2}{k} \cdot a_2$$

where a_1 and a_2 are the areas of the faces, and D_1 and D_2 the corresponding displacements,

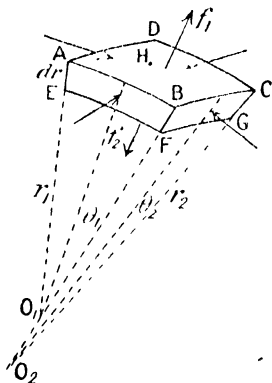

FIG. 141.

If O_1 is the centre of curvature of AB and EF , r_1 the radius of curvature of the sides EF and GH , and θ_1 the semi-angle subtended at the centre of curvature by EF ,

$$EF = 2r_1\theta_1, \text{ and, } AB = 2(r_1 + dr)\theta_1.$$

In a similar manner, $FG = 2r_2\theta_2$, and, $BC = 2(r_2 + dr)\theta_2$, so that $a_2 = 4r_1r_2\theta_1\theta_2$, and $a_1 = 4(r_1 + dr)(r_2 + dr)\theta_1\theta_2$.

Neglecting the small quantity $(dr)^2$, we have—

$$a_1 - a_2 = 4(r_1 + r_2)\theta_1\theta_2 \cdot dr,$$

$$\text{and, } f_2 - f_1 = \frac{2\pi D^2}{k} \cdot 4(r_1 + r_2)\theta_1\theta_2 \cdot dr.$$

For the section to be in equilibrium, the pressures over the sides must produce a resultant force in the direction f_2 , equal and opposite to the above.

Again, if p be the lateral pressure; force over side $ABFE = p \cdot 2r_1\theta_1 \cdot dr$, and this is inclined at angle $\left(\frac{\pi}{2} - \theta_2\right)$ to f_2 . Hence component parallel to f_2 is $2 \cdot pr_1\theta_1 \cdot dr \cdot \sin \theta_2$. But if the element is small θ_2 may be written for $\sin \theta_2$, so that—

$$\text{force parallel to } f_2, \text{ for side } ABFE, = 2pr_1\theta_1\theta_2 dr,$$

$$\text{and for the two opposite sides taken together} = 4pr_1\theta_1\theta_2 dr.$$

In an exactly similar manner we see that the component due to the pair of sides $BCGF$ and $ADHE$ is $4pr_2\theta_1\theta_2 dr$,

$$\therefore \text{resultant force parallel to } f_2 = p \cdot 4(r_1 + r_2)\theta_1\theta_2 dr.$$

$$\therefore f_1 - f_2 = \frac{2\pi}{k} (D_1^2 a_1 - D_2^2 a_2)$$

$$= \frac{2\pi}{k} (D_1 D_2 a_2 - D_1 D_2 a_1)$$

since $D_1 a_1 = D_2 a_2$ (p. 131),

$$\therefore f_1 - f_2 = \frac{2\pi D_1 D_2}{k} (a_2 - a_1).$$

Since $a_1 > a_2$, it follows that $f_2 > f_1$, and there is a resultant force acting in the direction of f_2 . Also, if the thickness of the slice is small, we may write D^2 in place of $D_1 D_2$.

\therefore resultant force in the direction of f_2 is

$$\frac{2\pi D^2}{k} (a_1 - a_2).$$

Comparing this with the value of $f_2 - f_1$, we see that for equilibrium—

$$p = \frac{2\pi D^2}{k}.$$

When the two ends of an element of a tube are parallel to each other, we have just seen that the stresses over the ends are in equilibrium with the pressures over the sides; but in an electric field the tubes are not in general straight, and where they are curved, the tensions over the two ends of an element of the tube have a resultant at right angles to the tube, and it is necessary for us to see whether the tube is still in equilibrium under the equal longitudinal tension and lateral pressure $\frac{2\pi D^2}{k}$. If the tube

is curved, let the plane of the diagram (Fig. 142) be taken through the direction of curvature. Let

the section of the tube considered be short enough for us to take D as constant over its length, then the tension $\frac{2\pi D^2}{k}$ at each end will

give rise to forces $\frac{2\pi D^2}{k} \cdot b dr$, and since these are equally inclined to the median line BO , and θ is small—

$$\text{Resultant force along } BO = 2 \frac{2\pi D^2}{k} b \cdot dr \cdot \theta.$$

D is the mean displacement over one end, but it is different at the outer and inner sides A and B ; for, the ends being equipotential surfaces, the p.d. as measured along A from one face to the other is equal to that as measured along B ; that is—

$$E_1(r + dr)\theta = E_2 r \theta.$$

$$\text{But, } E_1 = \frac{4\pi D_1}{k}, \text{ and, } E_2 = \frac{4\pi D_2}{k},$$

$$\therefore D_1 \cdot (r + dr) = D_2 \cdot r.$$

Thus p_1 , the lateral pressure over A , is $\frac{2\pi D_1^2}{k}$, and the resultant force over the outer face A is $\frac{2\pi D_1^2}{k} \cdot 2(r + dr)\theta \cdot b$, and that over B is $\frac{2\pi D_2^2}{k} \cdot 2r \cdot \theta \cdot b$.

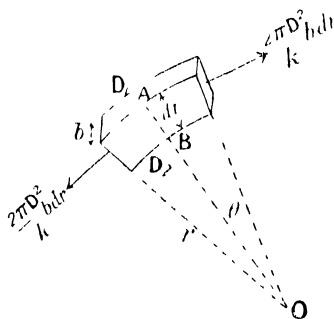

FIG. 142.

Since these both act in the line BO—

$$\begin{aligned} \text{Resultant force on element} &= \frac{4\pi}{k} \cdot \theta b \{D_1^2(r + d_1) - D_2^2 r\} \\ &= \frac{4\pi}{k} \theta b \{D_1 D_2 r - D_1 D_2 (r + d_1)\} \\ &= -\frac{4\pi D_1 D_2}{k} \cdot \theta b \cdot dr. \end{aligned}$$

This is directed outwards, and writing D^2 instead of $D_1 D_2$, we see that this is equal and opposite to the resultant of the forces over the ends due to the tension, and the element is in equilibrium. Since the result is obtained on the assumption that $p_1 = \frac{2\pi D_1^2}{k}$, and $p_2 = \frac{2\pi D_2^2}{k}$, we see that our assumption is justified.

Limitations of Maxwell's Theory.—That the electrostatic forces on charged conductors may be represented in terms of Maxwell's tension in the direction of the electric field and pressure at right angles to it, is undoubtedly true, but directly we attempt to form an idea as to the nature of the medium in which these stresses exist, we meet with grave difficulties. It has been pointed out by Poincaré¹ that if the energy $\frac{kE^2}{8\pi}$ is potential energy due to a state of strain in the medium, any change in its value for a given space can be calculated in terms of the changes in position of the walls of this space: for simplicity let $k = 1$.

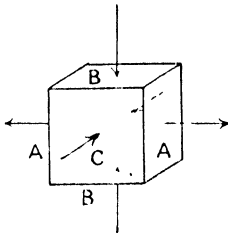

FIG. 143.

$$\text{Then, } w = \frac{E^2}{8\pi}, \text{ and, } dw = \frac{2E dE}{8\pi}.$$

Consider a unit cube in the dielectric, with tensions acting over the faces A A, and pressures over B B and C C (Fig. 143). If the medium possesses elasticity, we shall have a displacement, say e , outwards for A A and inwards for B B and C C, and if e changes by the amount de —

$$\begin{aligned} \text{Work done on account of displacement of A A} &= \frac{E^2}{8\pi} de \\ \text{'' '' '' '' B B} &= -\frac{E^2}{8\pi} de \\ \text{'' '' '' '' C C} &= -\frac{E^2}{8\pi} de \\ \therefore dw &= -\frac{E^2}{8\pi} de = \frac{2EdE}{8\pi}; \text{ from above equation.} \end{aligned}$$

¹ H. Poincaré, "Electricité et Optique."

$$\therefore -de = 2 \frac{dE}{E}$$

and on integrating, $-e = 2 \log E + C.$

This result is absurd, for when the medium is in equilibrium $E = 0$, and therefore, from our last equation, $e = \infty$. Hence Maxwell's idea of a state of strain in the medium, although extremely useful in studying electrical effects, breaks down, as Poincaré has shown, directly we attempt to give to the medium the properties of ordinary matter.

We shall see in Chapter XIV that, to account for the great velocities with which electrical disturbances are propagated in "empty space," the medium must have an elasticity greater than steel (Lord Kelvin), and in order to account for the fact that the motions of the heavenly bodies are not appreciably retarded by its presence, its density must be infinitesimal. These difficulties, however, arise from our fundamental ignorance of the nature of electricity and of the medium in which electrical forces are transmitted. Electrical and magnetic phenomena can be satisfactorily explained in terms of the ether, but all attempts to give a mechanical explanation of the ether have so far resulted in failure.

Motion of Tubes, and Electric Current.—The phenomenon of the electric current may be explained in terms of these tubes of induction. Electric charges are the ends of the tubes, and these are free to move upon the conductor, and will therefore slide along it until the tubes in the surrounding dielectric are in equilibrium. Thus, if the conducting plates A and B (Fig. 144) are oppositely charged, the ends of the tubes will slide along A and B until equilibrium is established. If, then, the plates are connected by a conductor CD, the opposite ends of the tubes nearest to CD, can approach each other, and owing to their tension these tubes will contract until they vanish. This removes the lateral pressure to the left of the tube EF, and hence the pressure upon the right will push this tube towards CD, and it will in turn vanish. The process will go on until all the tubes have disappeared. The motion of the positive ends along B and the negative ends along A constitutes the current.

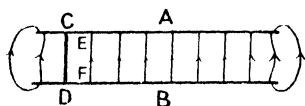

FIG. 144.

The magnetic field in the neighbourhood of an electric current has been interpreted by Sir J. J. Thomson in terms of the lateral motion of the Faraday tubes (p. 414).

Distribution of Charge upon a Conductor.—The fact that the surface of a conductor must be one of equipotential, aids us in determining the way in which a charge is distributed upon it. In the case of a symmetrical surface, such as a sphere or an infinite plane, the

problem presents no difficulty, the lateral pressures due to the tubes of induction ensuring a uniform distribution of charge. When this symmetry is departed from, the problem of finding exactly the distribution of charge and field presents great difficulties, but general reasoning will show us that on any given conductor in an open space

the charge is distributed so that the surface density is highest on parts of greatest convexity, becoming infinite at an actual point.

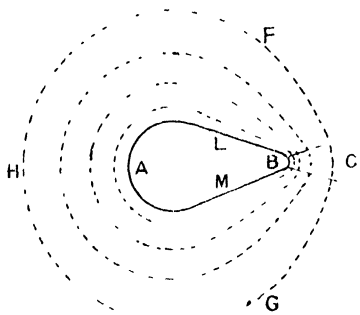

FIG. 145.

Taking a conductor of the form AB (Fig. 145) and drawing the equipotential surfaces in its neighbourhood, we see that near to it they follow its outline very closely, since the surface of the conductor itself is an equipotential surface. Owing to the great curvature of the equipotential surfaces in the neighbourhood of a point such as B, a tube of

induction such as BC has a very great divergence, that is, its cross-section varies rapidly as we pass from C and B. Now, for any given tube the product of electric displacement and area of section, that is, DS , is constant (p. 131), and therefore, as S becomes very small on approaching B, D necessarily becomes very great.

At a distance from the conductor, the equipotential surfaces, such as F G, are approximately spherical, and each unit tube of induction has here the same cross-section. The convergence towards B being greater than that towards A, the cross-section of a unit tube is less at B than at A, and the electric intensity at B is therefore greater than at A.

In the event of B being a point, S becomes zero and D infinite.

Remembering that $E = \frac{4\pi D}{k} = \frac{4\pi\sigma}{k}$, we see that the electric intensity in the neighbourhood of a point, and the surface density of charge on the point, are both infinite. But long before this condition is reached, the insulation of the air or other dielectric surrounding the conductor breaks down, and the charge passes from the point.

It has long been known that fine points facilitate the discharge of a conductor, and produce what is called an electric wind. This discharge from fine points has been used for many purposes, as in collecting the charge from the sectors of an electrical machine (p. 115).

A further examination of the equipotential surfaces of Fig. 145 shows us that we can easily obtain an idea of the surface density at all points of the conducting surface, and of the electric intensity of the field, for we cross the same number of equipotential surfaces in going from the conductor to the surface FG by whatever path we go, and

therefore the longer the path the less closely are the surfaces together. This means a less potential gradient and a weaker field. From B to C is the shortest path, and here we find the strongest field.

A similar method enables us to follow the effect of want of symmetry of the surrounding conductors upon a body itself symmetrical. For, taking a charged sphere AB inside a conducting sphere; both spheres are equipotential surfaces, and therefore in passing from A to C (Fig. 146) we cross as many equipotential surfaces as in going from B to D. Hence the field between A and C is stronger than that between B and D, and in the approximate ratio of the distances $BD : AC$. Remembering that $E = \frac{4\pi\sigma}{k}$, we see that the surface density of charge upon A is greater than that upon B.

Force on Uncharged Body.—The force on an uncharged body situated in an electric field may be determined in direction by a simple consideration of the energy of the field. In a uniform field of intensity of induction N, the energy per unit volume is $\frac{kE^2}{8\pi} = \frac{N^2}{8\pi k}$, since $N = kE$,

so that for a body of dielectric constant k situated in the field, $\frac{N^2}{8\pi k}$ is the energy per unit volume of the body; whereas if the space occupied by the body had been occupied by air the energy per unit volume would have been $\frac{N^2}{8\pi}$. Since k is usually greater than unity, the energy of the

field when occupied by a body is less than when the space is occupied by air, and for such a body situated in air, the energy of the whole system of air and body is less when the body is present than when it is not. If the field be uniform, the energy is the same wherever the body may be situated, and there is consequently no tendency for the body to move from one place to another. If, however, the field is not uniform, the energy of the whole system is less when the body occupies a position where N is great than in one where N is not so great. Now, it is a general principle in dynamics that a system will

always tend to that configuration for which the total potential energy is least, so that in our case the body will experience a force urging it from points of weaker to points of stronger field. Owing to the difficulty of determining the distribution of N in the case of a body situated in a field which is not uniform, we cannot, as a rule, employ the above reasoning to calculate the actual force on the body, but the general principle holds that the force acts towards the place of greatest field.

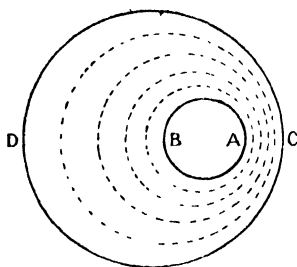

FIG. 146.

In the case of a conducting body, the induction N inside it is zero. The energy within the body is therefore zero, and from the above principle of least potential energy, the conductor will experience a force urging it from weaker to stronger parts of the field.

The above reasoning explains why a charged body will attract an uncharged one, as in the case of the rubbed amber or ebonite attracting light bodies, such as the pith ball.

Boundary Conditions.—At the surface of separation of two different dielectrics, certain conditions must hold, which conditions may be obtained in quite a simple manner. For convenience we shall first study the condition applying to a field whose direction is parallel to the surface of separation, and then consider the case of a field normal to this surface.

(i) *Field Parallel to Surface of Separation.*—Let k_1 and k_2 be the dielectric constants of the two media, and E_1 and E_2 the fields in each. Draw two equipotential surfaces A and B (Fig. 147) through the surface of separation and an infinitesimal distance dl apart. Then A and B must be parallel, since equipotential surfaces are always perpendicular to the field, and, further, the potential difference $V_A - V_B$ is for the first medium $E_1 dl$, and for the second $E_2 dl$.

Since these are equal, $E_1 = E_2$, so that our first boundary condition is, that the tangential components of the electric intensity are the same on the two sides of the surface of separation.

(ii) *Field normal to Surface of Separation.*—In this case, we take a small closed surface with ends parallel to the boundary and sides

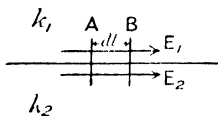

FIG. 147.

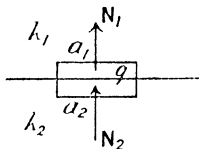

FIG. 148.

normal to it. Then, if N_1 and N_2 are the normal inductions taken positive in the direction from medium 2 to medium 1 (Fig. 148), the total normal induction over a_1 is $N_1 a_1$, and over a_2 is $N_2 a_2$, and if a charge q be situated on the boundary we have, from Gauss's theorem—

$$N_1 a_1 - N_2 a_2 = 4\pi q$$

or since $a_1 = a_2$ —

$$N_1 - N_2 = 4\pi\sigma, \text{ because } \sigma = \frac{q}{a}.$$

In the particular case when there is no charge upon the surface of separation—

$$\sigma = 0, \text{ and, } N_1 = N_2$$

thus the second condition is that *the normal component of the induction is the same in both media.*

Since $N = kE$, condition (ii) may be written $k_1 E_1 = k_2 E_2$.

These two conditions are of great importance in the study of the problem of the reflection of electromagnetic waves, by a surface of discontinuity.

The two boundary conditions enable us to find the change in direction of the field as we pass from one medium to another. For let θ_1 be the angle between field and normal (Fig. 149) in the first medium, and θ_2 that in the second.

The first boundary condition gives us

$$E_1 \sin \theta_1 = E_2 \sin \theta_2, \text{ and the second,} \\ k_1 E_1 \cos \theta_1 = k_2 E_2 \cos \theta_2.$$

Therefore dividing one equation by the other—

$$\frac{\tan \theta_1}{\tan \theta_2} = \frac{k_1}{k_2}.$$

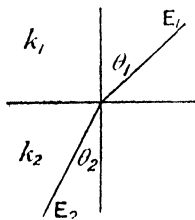

FIG. 149.

In the equation $N_1 - N_2 = 4\pi\sigma$, or $k_1 E_1 - k_2 E_2 = 4\pi\sigma$, σ is a charge which may be placed upon the surface or removed from it, and does not owe its existence to the discontinuity at the surface of separation. When this is zero, $k_1 E_1 = k_2 E_2$. Maxwell considered the difference in field $E_1 - E_2$ on the two sides of the medium to be due to a fictitious charge upon the boundary, which will, of course, disappear when the inductions N_1 and N_2 disappear. Thus, if the dielectric constants upon both sides of the surface become equal to unity, the intensities will remain unchanged, provided that this fictitious surface charge σ' remains upon the surface, σ' being obtained by putting $k_1 = k_2 = 1$ in the above equation.

$$\text{Then,} \quad E_1 - E_2 = 4\pi\sigma'$$

Remembering that $k_1 E_1 = k_2 E_2$ when there is no other than the fictitious charge on the surface, we see that—

$$4\pi\sigma' = \frac{k_2}{k_1} E_2 - E_2 = \frac{k_2 - k_1}{k_1} E_2 \\ = E_1 - \frac{k_1}{k_2} E_1 = \frac{k_2 - k_1}{k_2} E_1$$

If k_2 becomes equal to k_1 , which is not unity, we still obtain σ' as before. But in this case—

$$4\pi\sigma' = k_1(E_1 - E_2)$$

Thus for any given problem the intensities on the two sides of the boundary will be unchanged if we change the original dielectric constants k_1 and k_2 to unity and add a surface density of charge

$$\sigma' = \frac{1}{4\pi} \cdot \frac{k_2 - k_1}{k_2} E_1 = \frac{1}{4\pi} \cdot \frac{k_2 - k_1}{k_1} E_2.$$

Uncharged Sphere in Electric Field.—By the aid of this idea of a fictitious surface density we can solve the problem of the distribution of intensity in the case of a sphere situated in a medium whose dielectric constant differs from that of the sphere.

Let the dielectric sphere of constant k_2 be situated in a medium of dielectric constant k_1 , and let the field be uniform before the introduction of the sphere, the intensity being everywhere E . When the dielectric constant of the sphere changes to k_2 , we have for the surface condition for the normal component of the induction at the point P, Fig. 150, the relation $k_1 E_1 \cos \theta_1 = k_2 E_2 \cos \theta_2$, where E_1 and E_2 are fields just inside and outside the sphere at P. We may now produce exactly the same fields normal to the surface of the

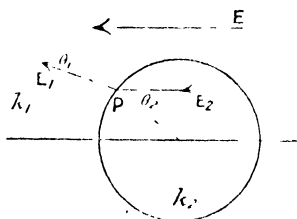

FIG. 150.

sphere, if we make the dielectric constant everywhere k_1 and introduce a fictitious surface density σ' given by

$$k_1 E_1 \cos \theta_1 - k_1 E_2 \cos \theta_2 = 4\pi\sigma' \quad (\text{p. 141}),$$

$$\text{or,} \quad k_2 E_2 \cos \theta_2 - k_1 E_2 \cos \theta_2 = 4\pi\sigma'$$

$$\sigma' = \frac{E_2 \cos \theta_2}{4\pi} (k_2 - k_1)$$

The dielectric constant being now everywhere k_1 , we have everywhere the original field E , together with that due to the fictitious surface density σ' .

A distribution of surface density which may be made to satisfy the conditions of the problem, was suggested by Poisson. Let the sphere be considered to have two volume densities of charge, $+\rho$ and $-\rho$, which coincide when there is no external field; but the sphere of positive charge is displaced relatively to the sphere of negative charge,

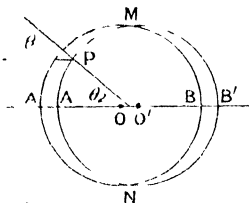

FIG. 151.

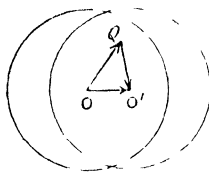

FIG. 152.

in the direction of the field, by the amount $OO' = AA' = BB'$ (Fig. 151), owing to the field E . $MANA'$ is then a layer of positive charge, and $MBNB'$ a similar layer of negative charge, and throughout the rest of the sphere the charges neutralize each other. When this displace-

ment is very small, the surface density at a point P is represented by the length of a radius intercepted between the spheres, which length is $OO' \cos \theta_2$.

Then the surface density at P is $\rho \cdot OO' \cos \theta_2$.

To find the field due to this distribution of charge, all that is necessary is to find that due to the two spheres. At a point Q the intensity due to the sphere, whose centre is O, and having volume density of charge $+\rho$, is equal to $\frac{1}{k_1} \frac{4}{3} \pi \cdot OQ \cdot \rho$ (see p. 127), and may be represented by the vector OQ (Fig. 152); that due to the other sphere is $\frac{1}{k_1} \frac{4}{3} \pi \cdot O'Q \cdot \rho$, and is represented by QO'. The resultant intensity may therefore, by the triangle of forces, be represented by the vector OO', and the intensity is $\frac{1}{k_1} \frac{4}{3} \pi \cdot OO' \rho$; and since this is parallel to OO' and is independent of the position of Q, the field inside the sphere is uniform and parallel to the original field. By finding the value of the intensity due to this distribution everywhere, and combining it with E, we get the resultant field everywhere.

Within the sphere, the field due to the charges is opposite in direction to the original field, so that the resultant field E_2 is the difference between these, is everywhere parallel to E, and is constant. For the boundary condition at the surface of the sphere to be satisfied,

$$\sigma' = -\frac{E_2 \cos \theta_2}{4\pi} (k_2 - k_1)$$

and since the surface density due to the volume distributions is $\rho \cdot OO' \cdot \cos \theta_2$, we have

$$\rho \cdot OO' = \frac{E_2(k_2 - k_1)}{4\pi}.$$

And again, since, $E - E_2 = \frac{1}{k_1} \cdot \frac{4}{3} \pi \cdot OO' \cdot \rho$,

$$\frac{E_2}{4\pi} (k_2 - k_1) = \frac{3}{4\pi} \cdot k_1 (E - E_2),$$

$$E_1(k_2 - k_1) + 3E_2k_1 = 3k_1E,$$

$$E_2 = \frac{3k_1}{k_2 + 2k_1} E.$$

The field outside the sphere may be found by combining the uniform field E with that due to the charges $+\frac{4}{3}\pi a^3 \rho$ situated at O, and $-\frac{4}{3}\pi a^3 \rho$ situated at O', remembering that the dielectric has a constant k_1 .

In the case of a conducting sphere situated in air, $k_2 = \infty$ and $k_1 = 1$.

$$\therefore E_2 = \frac{E}{\infty} = 0,$$

which is in accordance with fact, since the intensity inside a conductor is zero. Also when $\theta_2 = 0$,—

$$\sigma' = OO' \cdot \rho = \frac{3}{4} \cdot \frac{k_1}{\pi} (E - E_2)$$

and since $E_2 = 0$, and $k_1 = 1$ —

$$\sigma' = \frac{3}{4\pi} E, \text{ at the points A and B (Fig. 151).}$$

At any other point of the sphere $\sigma' = \frac{3}{4\pi} E \cos \theta_2$.

It may be shown that the field inside an ellipsoid with one axis parallel to E is also uniform, and the case of the sphere deduced from that of the ellipsoid by making the axes equal. The problem presents mathematical difficulties which preclude the discussion of it here,

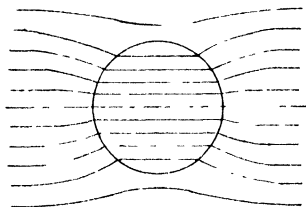

FIG. 153.

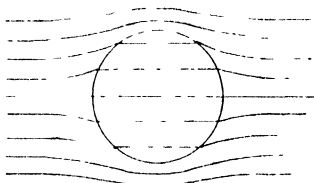

FIG. 154.

but the student may find it in "Absolute Measurements in Electricity and Magnetism," by A. Gray.

In order to determine the field outside the sphere we may calculate that due to the two charges $+\frac{4}{3}\pi a^3 \rho$ and $-\frac{4}{3}\pi a^3 \rho$, placed at O and O' respectively. From analogy with the case of a small magnet (p. 5) we can see that the field is equal to that due to a magnet of moment

$$\begin{aligned} \frac{4}{3}\pi a^3 \rho \cdot OO', \text{ or, } a^3 k_1 (E - E_2) &= a^3 k_1 \left(1 - \frac{3k_1}{k_2 + 2k_1}\right) E \\ &= a^3 \frac{k_1(k_2 - k_1)}{k_2 + 2k_1} E \end{aligned}$$

Fig. 153 represents the resultant field for a sphere, when $k_2 > k_1$. In Fig. 154, $k_2 < k_1$.

Electrical Images.—*Conducting Plane.*—The distribution of charge upon conductors may in several cases be most simply found by the method of electrical images, due to Lord Kelvin. Let us find the distribution of charge over a plane conducting surface, due to the presence of a positive charge $+q$ situated at P (Fig. 155), when the plane is maintained at zero potential. At P', a point on the opposite side of the plane to P, so that $PL = P'L$, and PLP' is normal to the plane, place a charge $-q$. This charge is said to be the electrical image of P, the name being suggested by the optical analogy. We must show that this analogy may be pushed further; in fact, for all points on the P side of the plane the effect of the plane is exactly the same as that produced by the image, the plane being removed.

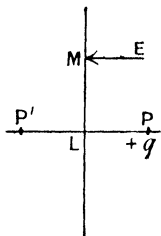

FIG. 155.

In the first place, the potential at M is

$$+ \frac{q}{PM} - \frac{q}{P'M} = 0,$$

so that if the conductor were removed and the charge $-q$ placed at P' instead, every point of the plane LM would still be at zero potential.

Again, the electric intensity E, at the point M is given by

$$\begin{aligned} E &= \frac{q}{PM^2} \cdot \frac{PM}{PM} \quad (\text{compare with field due to magnet, p. 4}) \\ &= \frac{2q \cdot PL}{PM^3} \end{aligned}$$

But if $-\sigma$ is the surface density of charge at M, we have from Coulomb's law (p. 128)

$$E = -4\pi\sigma$$

and if these two are to be the same,

$$\begin{aligned} -4\pi\sigma &= \frac{2q \cdot PL}{PM^3} \\ \sigma &= -\frac{q \cdot PL}{2\pi PM^3} \end{aligned}$$

which determines the value of σ at all points on the plane. The two distributions $+q$ and $-q$ on the one hand, and $+q$ and $-\sigma$ on the other, both make LM a surface of zero potential, and both produce the same intensity at points immediately in contact with the plane, and since the component of the intensity due to P at any point is the same in both cases, it follows that the intensity near the plane due to $-q$ at P' is identical with that due to $-\sigma$ on the plane. Moreover, it follows that if $+q$ and $-q$ on the one hand, and $+q$

and the distribution $-\sigma$ on the other, each make the potential of the plane zero, the intensity at every point on the P side of LM, due to the two distributions, must be the same. For if possible let the intensity due to the former arrangement be E_1 and that due to the latter E_2 . In the second case reverse all the charges, E_2 becoming, of course, $-E_2$, with charge $-q$ at P and distribution $+\sigma$ upon the plane. If we now superimpose the second distribution on the first, the charge is everywhere zero, and the field at the given point is $E_1 - E_2$. But the space to the right is surrounded by an equipotential surface made up of the plane LM and the rest of the enclosure at infinity, and as there is no charge within it, it follows from the theorem on p. 129, that the intensity within it must be everywhere zero, that is, $E_1 - E_2 = 0$ or $E_1 = E_2$, and thus the intensity due to the two distributions is everywhere the same.

Further, we can show that if the given distribution $-\sigma$, which produces a field everywhere on the P side of LM, produces an intensity equal to that due to $-q$ at P'; no other surface distribution can do so. For if possible let another $-\sigma'$, whose value is not everywhere the same as $-\sigma$, give the same intensity as $-\sigma$. Let this latter charge $-\sigma'$ be reversed and superimposed upon $-\sigma$. The intensities now cancel out everywhere, but the charges do not. Thus at a given point on the plane, the resulting surface density is $\sigma' - \sigma$, and on drawing a closed surface to enclose this, the normal induction over it is $4\pi(\sigma' - \sigma)$, but P does not lie within the surface, and therefore by Gauss's theorem $+q$ cannot contribute to the total normal induction over it, and the field due to σ and σ' is everywhere zero; hence the total normal induction over this closed surface is zero, and $\sigma = \sigma'$. That is, there is only one distribution of σ that can satisfy the problem, and since one has been found, it must therefore be the only one possible.

Thus the charge $+q$ situated at P produces a surface density $-\frac{qPL}{2\pi PM^2}$ at the point M of the conducting plane. There is evidently an attraction between $+q$ and the negatively charged plane, the value of which can be found by replacing the charge on the plane by the electrical image of P.

$$\text{Force} = -\frac{q^2}{(2PL)^2} = -\frac{q^2}{4PL^2}$$

Electrical Images.—*Conducting Sphere.*—The only other case of an electrical image which we will consider in detail is that of a charge $+q$, produced by a spherical conducting surface at zero potential. Let the point P' within the sphere of radius r (Fig. 156) be found such that $OP \cdot OP' = r^2$.

Then,

$$\frac{OP}{OM} = \frac{OM}{OP'}$$

To find the surface density of charge $-\sigma$ at the point M, resolve the intensity $\frac{q}{PM^2}$ along OM, and parallel to OP. From Fig. 156, SMR is the triangle of forces, and is similar to OMP, so that the component MS along the radius is equal to

$$\frac{q}{PM^2} \cdot \frac{MS}{MR} = \frac{q}{PM^2} \cdot \frac{OM}{PM} = \frac{qr}{PM^3}.$$

Also the triangles MVW and MOP' are similar, and the component of MW, or $q \frac{P'M}{PM} \cdot \frac{1}{P'M^2}$, in the direction of the radius OM is

$$q \cdot \frac{P'M}{PM} \cdot \frac{1}{P'M^2} \cdot \frac{MV}{MW} = \frac{q}{PM} \cdot \frac{OM}{P'M} = \frac{qr}{PM \cdot P'M^2} = \frac{qd^2}{r \cdot PM^3}$$

Similarly the components MX and MY parallel to OP are $q \frac{RS}{PM^2} \cdot \frac{RM}{PM} = \frac{q}{PM^2} \cdot \frac{OP}{PM} = \frac{qd}{PM^3}$, and

$$q \cdot \frac{P'M}{PM} \cdot \frac{1}{P'M^2} \cdot \frac{OP'}{P'M} = \frac{q}{PM} \cdot \frac{OM}{P'M} = \frac{qr}{PM^2 \cdot P'M} = \frac{qd}{P'M^3}$$

respectively, and are therefore equal and opposite. The resultant is therefore along the radius, and the intensity is

$$E = \frac{qr}{PM^3} - \frac{qd^2}{r \cdot PM^3} = \frac{qr}{PM^3} \left(1 - \frac{d^2}{r^2}\right)$$

But by Coulomb's theorem (p. 128), $E = 4\pi\sigma$,

$$\therefore \sigma = \frac{qr}{4\pi \cdot PM^3} \left(1 - \frac{d^2}{r^2}\right).$$

We therefore see that the surface density of charge on a sphere when a point charge is brought into its neighbourhood ceases to be uniform, but the attraction between the two may nevertheless be calculated by means of the method of electrical images.

CHAPTER VI

ELECTROSTATICS (*continued*)

MEASUREMENTS

Capacity.—We have seen that for any given dielectric, the ratio of the induction to the electric intensity is called the dielectric constant or specific inductive capacity. The absolute constancy of this quantity has only been established for media such as the gases, for which the value of k is very nearly unity: in other cases its value depends upon the time for which the field is applied. Thus, if its value be deduced from measurements made with very rapidly alternating fields, the value of k is found to diminish as the alternations become more rapid. For the present, however, we shall deal with k as though it had a definite and constant value for each substance.

Sphere.—Consider an insulated sphere whose potential is originally zero; when a charge q is placed upon it, the potential at the surface of the sphere becomes $\frac{q}{a}$, where a is the radius of the sphere, provided that the charge is uniformly distributed over it, and that the sphere is surrounded by air. The potential is proportional to the charge, and the ratio of one to the other is called the capacity.

Thus for the sphere, $V = \frac{q}{a}$, or $\frac{q}{V} = a$, and the capacity is equal to the radius.

In any case the capacity of a conductor is the ratio of the charge placed upon it to the resulting change in potential, or is the amount of charge which will raise the potential by unity.

Concentric Spheres.—The capacity of a sphere of radius a surrounded by a concentric sphere of radius b maintained at zero potential may now be easily found (Fig. 157).

The inner surface of b , being conducting, is an equipotential surface, and therefore when a charge $+q$ is placed on a , there will be an equal and opposite charge $-q$ situated upon the inner side of b (see p. 129).

Then potential of a due to its own charge is $+\frac{q}{a}$, and the potential

throughout the space inside b due to the charge on the inner surface of b is $-\frac{q}{b}$.

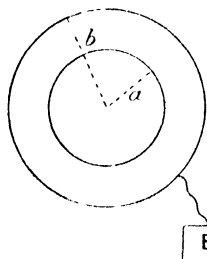

FIG. 157.

$$\therefore \text{resulting potential of } a = \frac{q}{a} - \frac{q}{b} = V.$$

$$\text{But capacity} = \frac{q}{V},$$

$$\therefore C = \frac{1}{\frac{1}{a} - \frac{1}{b}} = \frac{ab}{b - a}$$

This is necessarily greater than a , and therefore the capacity is increased by the presence of b .

For practical purposes the zero of potential is taken as that of the earth. Since potential is only recognizable by its differences, we may take that of the earth as zero without affecting our calculations. Thus we say that the sphere b is "earthed."

Cylindrical Condenser.—The capacity per unit length of a cylinder surrounded by an earthed coaxial cylinder is determined by finding the difference of potential between the inner and outer coatings when the charge per unit length of the inner one is $+q$.

The electrical intensity at a distance r from the axis (Fig. 158) due to the charge upon a is $\frac{2q}{r}$ (see p. 127). Therefore p.d. between inner and outer cylinder,—

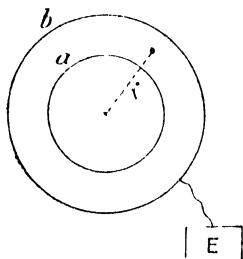

FIG. 158.

$$\begin{aligned} V_a - V_b &= - \int_b^a \frac{2q}{r} dr \\ &= - 2q \left[\log_e r \right]_b^a \\ &= 2q \log_e \frac{b}{a} \end{aligned}$$

$$\begin{aligned} \text{But if } b \text{ is earthed, } V_b &= 0, \\ \therefore \text{capacity per unit length} &= \frac{1}{2 \log_e \frac{b}{a}} \end{aligned}$$

Parallel Plate Condenser.—The capacity per unit area of an insulated plate at a distance t from an earthed plate parallel to it may be found by giving the insulated plate a charge of surface density $+\sigma$. This is the surface density of the charge which faces the earthed plate, and will, unless there are conductors brought near the remote side of A (Fig. 159), be practically the whole of the charge upon A .

If such conductors are brought near A, of course the problem is changed, but we are only concerned here with the charge on the side facing B. Electric intensity in the space between A and B is $4\pi\sigma$ (p. 128).

$$\begin{aligned} \therefore V_A - V_B &= \int_B^A 4\pi\sigma \cdot dt \\ &= 4\pi\sigma t, \end{aligned}$$

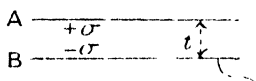

FIG. 159.

$$\therefore \text{capacity of unit area of A} \left. \vphantom{\begin{matrix} \sigma \\ 4\pi\sigma t \end{matrix}} \right\} = \frac{\sigma}{4\pi\sigma t} = \frac{1}{4\pi t}$$

[E]

Effect of Dielectric on Capacity.—The effect of a dielectric other than air separating the conductors is to increase the capacity in all cases.

Thus for the cylindrical condenser, $E = \frac{2q}{kr}$,

$$V_a - V_b = - \int_b^a \frac{2q}{kr} dr,$$

$$V_a = \frac{2q}{k} \log_e \frac{b}{a},$$

$$\text{and, capacity} = \frac{k}{2 \log_e \frac{b}{a}}$$

For the plates, field between A and B = $\frac{4\pi\sigma}{k}$ (Fig. 159),

$$\therefore V_A - V_B = \frac{4\pi\sigma t}{k},$$

$$\text{and capacity} = \frac{k}{4\pi t}$$

In fact, in any case, since the electric intensity is everywhere diminished in the ratio $1:k$, the potential is diminished in the same ratio, and the charge required to bring the potential back to that for an air condenser must be increased in the ratio $k:1$. It was owing to the increase in capacity caused by various dielectrics, that the effect of the medium was first noticed. Faraday measured the dielectric constant, or, as he called it, the *specific inductive capacity* of a number of substances by comparing the capacity of two similar condensers, one having the substance, and the other air, as dielectric.

Condensers.—The most commonly used form of capacity is the Leyden jar (Fig. 160), which is frequently a glass jar coated inside and outside for about two-thirds of its depth with tinfoil, the remaining glass surface

being coated with shellac varnish, to improve the insulation. The outer coating is usually sufficiently well earthed by standing on an ordinary table, and contact with the inner coating is made through a metallic knob and stand. If A be the area of the inner coating, and t the thickness of the glass, the capacity is about $\frac{6A}{4\pi t}$, the dielectric constant of the glass being about 6.

Many *standard condensers* are constructed of layers of tinfoil separated by sheets of mica, the alternate layers of tinfoil being connected respectively to the terminals T and T' (Fig. 161). The mica being an extremely good insulator, and at the same time very thin, a great capacity can be obtained without the necessity of great

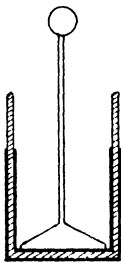

FIG. 160.

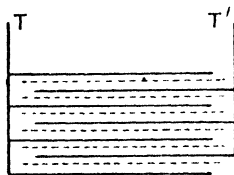

FIG. 161.

bulk. The dielectric constant of mica is about 6. For convenience in use, condensers are made up in a manner similar to that of resistance boxes, but it must be remembered that to add the capacities, the condensers must be placed in parallel, not in series. With the plugs as shown in Fig. 162 the whole capacity, namely, one microfarad, is being used.

Condensers in Parallel.—Thus in Fig. 163, C_1 , C_2 , C_3 are three

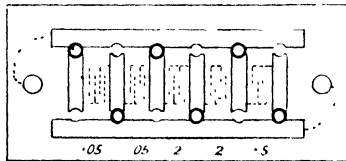

FIG. 162.

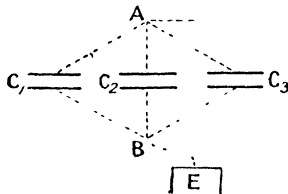

FIG. 163.

condensers connected in parallel between A and B , and the same p.d. exists between the terminals of the three. Let p.d. = V .

Then if q_1 , q_2 , and q_3 be the charges upon each,

$$q_1 = C_1V, \quad q_2 = C_2V, \quad q_3 = C_3V,$$

$$\text{and,} \quad q_1 + q_2 + q_3 = (C_1 + C_2 + C_3)V.$$

$$\begin{aligned} \text{But, total capacity } C &= \frac{\text{total charge}}{V} \\ &= \frac{q_1 + q_2 + q_3}{V}, \\ &= C_1 + C_2 + C_3. \end{aligned}$$

Condensers in Series.—If the condensers are connected in series as in Fig. 164, the combined capacity may be found from the fact that the charges upon the opposite plates of each condenser are equal. Thus if the charge $+q$ is situated upon one plate of C_1 , $-q$ is situated on the other. Hence the charge $+q$ has passed to the first plate of C_2 , and so on.

$$\text{Then,} \quad V_A - V_E = \frac{q}{C_1},$$

$$V_E - V_F = \frac{q}{C_2},$$

$$V_F - V_B = \frac{q}{C_3},$$

$$\therefore V_A - V_B = q \left(\frac{1}{C_1} + \frac{1}{C_2} + \frac{1}{C_3} \right).$$

But, $\frac{q}{V_A - V_B}$ is the combined capacity C ,

$$\therefore \frac{1}{C} = \frac{1}{C_1} + \frac{1}{C_2} + \frac{1}{C_3}.$$

In the case of most condensers used for practical purposes, the capacity has been found by comparison with a standard, whose value can be calculated from its geometrical form. The simplest case is that of a sphere whose capacity is equal to its radius, but a sphere would have to be of such great size to have a sufficient capacity for practical purposes that this consideration alone would prevent its use. But in addition, we have the fact that the sphere must be at an infinite distance from all other bodies for the surface density of charge to be uniform and the field everywhere radial. A pair of concentric spheres would get over both these difficulties, but then we meet with the objection that it is difficult to construct the spheres and to arrange them to be concentric, and the insulation of the inner sphere would also give trouble.

Guard-Ring Condenser.—The first satisfactory standard condenser to be made was the guard-ring condenser of Lord Kelvin. In the case of the parallel plate condenser, an uncertainty in the effective



area of the insulated plate arises from the fact that the field near the edge of the plate is not uniform (see Fig. 165). Lord Kelvin got over this difficulty by making the insulated plate circular and surrounding

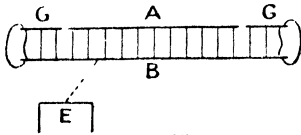

FIG. 165.

it by a guard-ring, so that the irregularity of the field does not occur at the edge of A, but at that of the guard-ring G. There is still a slight irregularity in the field where the gap between A and G occurs, but if this gap is not very wide, Kelvin found that the effective area of the plate is the arith-

metrical mean of the area of the plate A and the circular hole in G. Calling this effective area A,

$$\text{Capacity} = \frac{kA}{4\pi t}$$

Fig. 166 illustrates the guard-ring condenser,¹ the left-hand half of

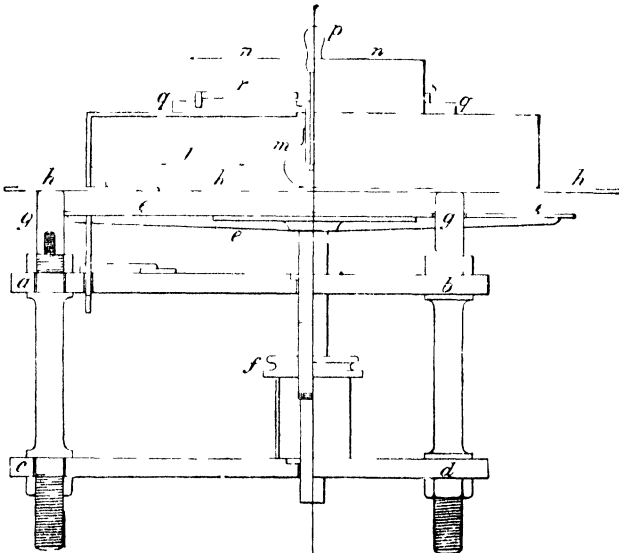

FIG. 166.

the figure being in section. *h*, the guard-ring, and *k*, the plate, can be insulated or connected together, and the parallel earthed plate *e* can be raised or lowered by means of the micrometer screw *f*. The distance apart of the plates is measured by bringing *e* into contact with *k* and *h*. The reading of the micrometer screw is observed and *e* is then

¹ J. Hopkinson, *Phil. Trans.*, 169, p. 17. 1878.

lowered by turning the screw, and the reading again taken. On subtracting one micrometer reading from the other, the distance t is obtained. In using the instrument, e is earthed, and h and k connected together and charged. On then earthing h , the charge upon k remains and has the value corresponding to the capacity $\frac{kA}{4\pi t}$.

Sliding Condenser.—Another convenient form is the sliding or cylindrical condenser, also due to Lord Kelvin. A and C (Fig. 167) are two coaxial cylinders of the same diameter, with a small gap separating

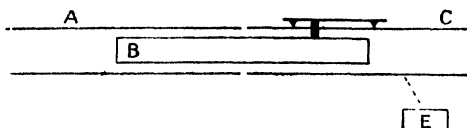

FIG. 167.

The smaller cylinder B is coaxial with the other two and is carried by a support which slides upon C , so that the length lying within A can be varied and measured. A is insulated and B and C are earthed. Then, if B is caused to slide in or out of A by the distance l , the change in capacity of A is $\frac{kl}{2 \log \epsilon \frac{a}{b}}$. A is surrounded by an earthed metallic tube to pre-

vent its capacity from being varied by the movement of conductors in its neighbourhood. This condenser has not a capacity of known absolute value, but its change in capacity for any movement of B is known from its dimensions. If a scale of lengths be attached to the slider, and the absolute capacity be determined experimentally for one position, that for other positions of the scale will then be known.

Another useful variable condenser made by Mr. A. C. Cosser, is shown in Fig. 168. A number of semicircular plates are insulated, and between them and parallel to them are a number of similar plates mounted upon an axle, so that they may be rotated to occupy any position from lying entirely within or entirely external to the fixed plates. This is really a multiple parallel plate condenser, and the relative

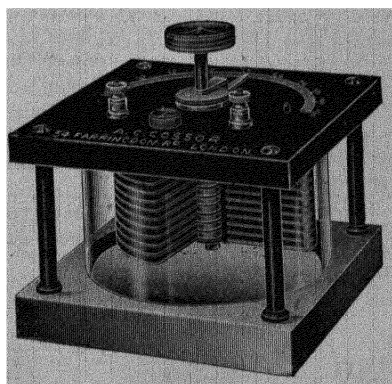

FIG. 168.

position of the plates may be determined by means of a pointer moving over a circular scale. The condenser is not an absolute one, and the scale must be calibrated by experimental comparison with known standard condensers.

Electrometers.—For the comparison of capacities, some measurer of potential is necessary. The electromagnetic voltmeter described in Chapter IV. is, of course, useless, since its reading depends upon the existence of a current, which is exactly what must be avoided in dealing with electrostatic charges; in fact, the difficulties met with are largely due to faulty insulation, which allows minute currents to flow, and hence the charges to leak away.

Faraday used the gold-leaf electroscope as an electrometer, but its low sensitiveness and the uncertainty in the value of its readings restrict its use. Quite recently the gold-leaf electroscope has been so modified in form that its use as an electrometer has been greatly extended (see p. 498).

Attracted Disc Electrometer.—More exact electrometers, depending upon a measurement of the attraction between two conductors,

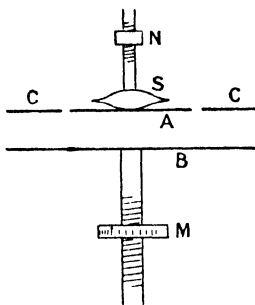

FIG. 169.

maintained at different potentials, have been designed, and after many modifications, the instrument took the form of the *Attracted Disc Electrometer*, which, in the case of Lord Kelvin's pattern, is an "absolute" instrument, the potential difference being found in terms of a force, a length, and an area. The arrangement is shown diagrammatically in Fig. 169. A is the attracted plate, which is carried by a spring S, and situated in the plane of the guard-ring C, just as in the case of the guard-ring condenser. A is maintained at a constant potential, and B, which can be raised or lowered by means of the micrometer screw M, is brought in turn into

contact with the bodies, the difference of potential between which it is required to determine.

To calculate the attraction between A and B, let their potentials be V_a and V_b , and their distance apart t . The electric intensity E in the space between them is therefore $\frac{V_a - V_b}{t}$.

$$E = \frac{V_a - V_b}{t}.$$

Also from p. 132, we know that the force per square centimetre of either is $\frac{E^2}{8\pi}$, so that if A be the area of the plate A, the total force upon it is—

$$\frac{E^2}{8\pi} A = F,$$

$$\therefore F = \frac{(V_a - V_b)^2 A}{8\pi t^2},$$

$$\text{or, } V_a - V_b = t \sqrt{\frac{8\pi F}{A}}.$$

In using the instrument, the plates are to begin with, all earthed, and a small known weight m is placed upon A . This depresses it below the plane of C , and it is raised by means of the screw N until it again comes into the plane of C . The small weight is then removed, when, of course, the spring S pulls it above C , but if subsequently the attraction between A and B pulls A again into the plane of C , we know that the force acting on it is mg dynes, where g is the acceleration of gravity. A and C are now insulated and charged to a potential which is kept constant by means of a small electrical machine, the prototype of the Wimshurst machine, called the Kelvin replenisher, the constancy being observed by means of a second guard-ring condenser with fixed spring control and fixed position of earthed plate. B is then connected to the first of the points the p.d. between which we wish to measure, and its position adjusted by means of M until A is in the plane of C . The force on A is then mg , and if V_1 be the potential of the first point, and the micrometer M is read—

$$V_a - V_1 = t_1 \sqrt{\frac{8\pi mg}{A}}.$$

B is now connected to the second point, whose potential is V_2 , and the adjustment again made.

$$V_a - V_2 = t_2 \sqrt{\frac{8\pi mg}{A}}.$$

$$\text{Therefore, } V_2 - V_1 = (t_1 - t_2) \sqrt{\frac{8\pi mg}{A}}.$$

Thus $V_2 - V_1$ is known in terms of the difference of the two micrometer readings, the area of the plate A , and the weight of a small mass m . It is not necessary to know either the actual distance between A and B or the potential of A , but the latter must remain constant.¹

Quadrant Electrometer.—The Quadrant Electrometer bears a certain resemblance to the galvanometer, in that both give deflections proportional to the quantity to be measured, the deflection in each case

¹ For a detailed account of the construction of the absolute electrometer and its use, the student may consult "Absolute Measurements in Electricity and Magnetism," by A. Gray.

depending upon a number of constants of such an uncertain value, that the instrument is used for purposes of comparison only. The quadrant electrometer, like that of the attracted disc type, is evolved from others of simpler type and achieved its first satisfactory form at the hands of Lord Kelvin.

The Fig. 170 shows a typical arrangement of the instrument. Four hollow quadrants are connected in pairs AA and BB. A paddle-shaped conductor C, frequently called the "needle" from analogy with the galvanometer needle, is maintained at a high (or low) potential and is therefore positively (or negatively) charged. When A and B are at the same potential, the needle hangs symmetrically between them, but on establishing a difference of potential between A and B, the field produces a couple which rotates C until the control brings it to rest.

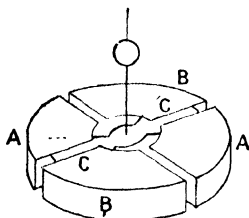

FIG. 170.

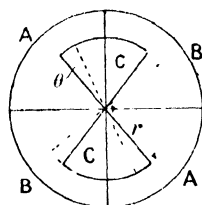

FIG. 171.

The deflection is approximately proportional to the potential difference between A and B. To prove this, imagine that the needle is charged to a high potential V_C , and the quadrants to potentials V_A and V_B , where $V_A > V_B$. Let these potentials be maintained by connection with sources of supply such as cells. Consider the needle to be held for a moment in its zero position and then released. It will then be deflected towards the B quadrants; that is, down the grade of potential. The requisite energy is all drawn from the source of supply, and is used in twisting the suspension and in increasing the potential electrical energy associated with the quadrants and needle. Equilibrium is attained when the first equals the sum of the other two.

If the resulting deflection is θ (Fig. 171), an area of needle equal to $\pi r^2 \theta / \pi = r^2 \theta$ has been transferred from the A quadrants to the B quadrants, and, remembering that there are two faces to the needle, the effective area transferred is $2r^2 \theta$. This is equivalent to diminishing the capacity of the A-C condenser by an amount $2r^2 \theta / 4\pi t = r^2 \theta / 2\pi t$, and increasing that of the B-C condenser by the same amount, t being the thickness of air space between needle and quadrants. Thus an amount of charge $r^2 \theta (V_C - V_A) / 2\pi t$ has been lost from the A-C condenser, and the corresponding loss of electrical energy is

$(V_C - V_A)r^2\theta(V_C - V_A)/2\pi t = r^2\theta(V_C - V_A)^2/2\pi t$, since the potentials have remained constant throughout. Similarly the amount of energy gained from the sources of supply on the B-C side is $r^2\theta(V_C - V_B)^2/2\pi t$. Thus the total energy supplied to the electrometer from the sources is—

$$\frac{r^2\theta}{2\pi t} \{ (V_C - V_B)^2 - (V_C - V_A)^2 \} = \frac{r^2\theta}{\pi t} (V_A - V_B) \left(V_C - \frac{V_A + V_B}{2} \right).$$

Again, the potential energy of the charges residing on the A-C condenser has been reduced by $\frac{1}{2}(\text{capacity})(\text{p.d.})^2 = r^2\theta(V_C - V_A)^2/4\pi t$, and the gain on the B-C side is $r^2\theta(V_C - V_B)^2/4\pi t$. Therefore the gain of potential energy of the charges residing on the electrometer is $\frac{r^2\theta}{2\pi t} (V_A - V_B) \left(V_C - \frac{V_A + V_B}{2} \right)$.

Also the work done in twisting the suspension is $\int_0^\theta c\theta d\theta = \frac{1}{2}c\theta^2$, where c is the couple for one radian twist,

$$\therefore \frac{1}{2}c\theta^2 + \frac{r^2\theta}{2\pi t} (V_A - V_B) \left(V_C - \frac{V_A + V_B}{2} \right) = \frac{r^2\theta}{\pi t} (V_A - V_B) \left(V_C - \frac{V_A + V_B}{2} \right)$$

$$\text{or,} \quad \theta = \frac{r^2}{\pi ct} (V_A - V_B) \left(V_C - \frac{V_A + V_B}{2} \right).$$

We see, therefore, that the deflection is proportional to $\frac{r^2}{\pi ct}$, which is a constant, to the difference of potential between A and B, and to the difference between the potential of C and the average potential of A and B. The last term is very nearly constant if V_C is great and V_A and V_B change very little during the experiment, and we may then say that—

$$\theta = K(V_A - V_B)$$

where K is a constant.

The shape of the needle is immaterial, provided that the change in area within each pair of quadrants is proportional to the deflection, which condition is fulfilled when the outer edge of the needle is circular, and the radial edges of the needle lie well within the quadrants.

In the method of use described above, the conductors A, B, and C are all at different potentials, and the instrument is said to be used *heterostatically*. It may also be used *idiostatically* by connecting C to one pair of quadrants, say B. Then $V_b = V_c$, and the equation for the deflection becomes—

$$\begin{aligned} \theta &= \frac{r^2}{2\pi ct} (V_a - V_b)^2 \\ &= K'(V_a - V_b)^2. \end{aligned}$$

In this case the constant K' is much smaller than K , since V_c is very great ($2K'V_c = K$). Hence for a given deflection, $V_a - V_b$ will generally be greater when the use is idiostatic than when heterostatic. The range of usefulness of the instrument is therefore considerably extended. It should be noted, however, that when the method is idiostatic, the deflection is proportional to the square of the p.d. to be measured. This is for some purposes inconvenient, but on the other hand it has the great advantage, that the deflection is in the same direction whether the p.d. is positive or negative, and the electrometer will therefore give a deflection with an alternating potential difference. This point will be dealt with in the chapter on alternating currents.

In the Kelvin instrument V_c is maintained constant by means of

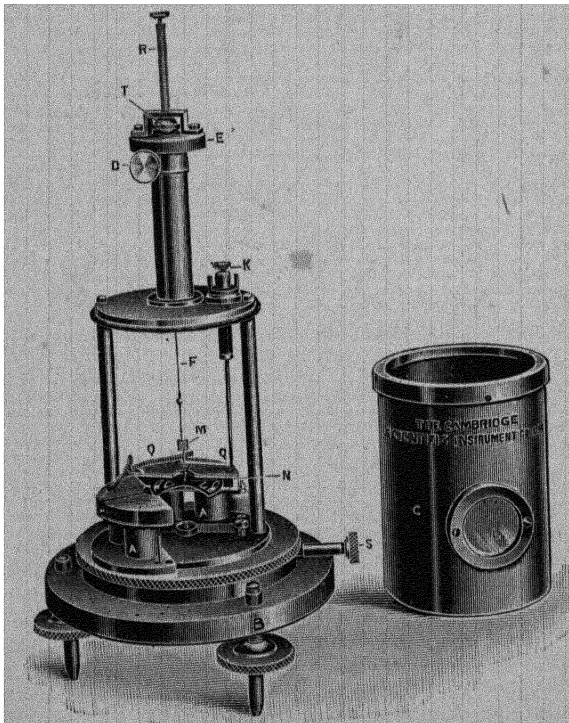

FIG. 172.

a replenisher and a trap door indicator, as in the case of the guarding electrometer, and further the constancy is assisted by placing C in connection with the insulated coating of a condenser of large

capacity. Also the control is produced by means of a bifilar suspension.¹

The type of quadrant electrometer most commonly used at the present time was designed by F. Dolezalek, and is shown in Fig. 172. The quadrants are of brass, and are mounted on amber pillars A to ensure good insulation. The needle N is of paper, thinly coated with metal, or in the latest instruments it is of thin aluminium. It is suspended by a quartz fibre which is made conducting by dipping it into a strong solution of calcium chloride, which, being very hygroscopic, maintains the surface of the fibre sufficiently conducting to keep the needle charged by means of a battery. The quartz fibre produces such a feeble control that a high sensitiveness is obtained, without the employment of very high potential for C. With a suitable fibre and a p.d. of 50 to 100 volts between the needle and earth, one volt will cause a deflection of 200 to 400 millimetres with a scale distance of a metre from the mirror. The deflection is usually observed by means of a lamp and scale, as in the case of the reflecting galvanometer. If the absolute values of the deflections are required, the scale must be calibrated by some known source of p.d., as for example a standard cell. If an insulating quartz fibre be used for the suspension, this will enable the needle to keep the charge for some time. The needle may always be recharged by means of the contact maker K.

Several *Electrostatic Voltmeters* have been designed on the principle of the quadrant electrometer.

The Kelvin multicellular voltmeter is essentially a quadrant electrometer, having a number of alternating quadrants, used idiostatically. It is provided with a pointer moving over a scale which has been experimentally calibrated. The moving sectors are suspended by a metal strip which also supplies the control.

Lord Kelvin has also constructed electrostatic voltmeters having a gravity control. AB is a fixed and CD a movable conductor (Fig. 173), the latter being supported on knife-edges at *e*. The p.d. which is established between AB and CD causes C to approach A, and D to approach B, and the couple is balanced against gravity. The range of the instrument may be varied by altering the little weight *b*. The scale is calibrated in volts, the range

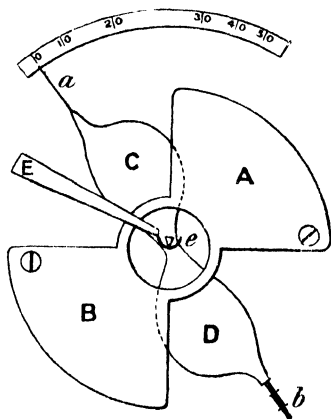

FIG. 173.

¹ For further description of the Kelvin quadrant electrometer the student is referred to the pamphlet issued by Messrs. Kelvin and White of Glasgow.

of the instrument with the largest weight extending up to several thousand volts.

Comparison of Capacities.—On p. 151 we saw that the capacity of any conductor is directly proportional to the dielectric constant of the medium in which it is situated, and therefore the measurement of the constant of any dielectric generally devolves upon the comparison of the capacities of two condensers, one with and the other without the given medium as dielectric.

Faraday's Method.—The first determination of dielectric constant was made by Faraday. He constructed two spherical condensers of the pattern shown in Fig. 174, as nearly as possible alike, and tested their equality in capacity by charging the inner sphere of one of them and then sharing its charge with the other, the outer spheres being earthed. He found that the potential fell to half, on the sharing of the charge taking place. The lower half of one of them, B, was then filled with shellac, and the other one, A, which had only air between the spheres, was given a charge. On sharing A's charge between the two, the potential did not fall to exactly half, showing that the capacities were no longer equal. Thus, if V_1 is the original potential of A, and V_2 the final common potential, the original potential of B being zero, calling C_a and C_b the capacities of A and B—

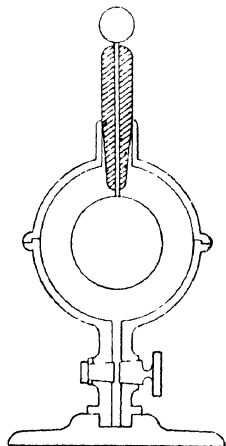

FIG. 174.

The charge passing from A to B, that is

$$q = C_a(V_1 - V_2) = C_bV_2,$$

$$\therefore \frac{C_b}{C_a} = \frac{V_1 - V_2}{V_2}$$

In this way it was found that $C_b = 1.50C_a$. Remembering that only half of B is filled with shellac of dielectric constant k , and that without shellac the capacities are equal,

$$C_b = k \cdot \frac{C_a}{2} + \frac{C_a}{2} = (k + 1) \frac{C_a}{2},$$

$$\therefore 1.50 = \frac{(k + 1)}{2},$$

which gave $k = 2$ for shellac.

In a similar manner Faraday found the dielectric constant of sulphur to be 2.2.

A considerable improvement in the comparison of capacities by the above method may be made by using the electrometer instead of the electroscope, but in this case the capacity of the electrometer itself may be appreciable, and should be taken into account.

If A be a standard condenser, it is first charged by depressing the key *p* (Fig. 175), and the electrometer deflection noted; let it be θ_1 . The key *p* is then opened and *q* closed, and the new deflection θ_2 noted. Since the potentials in the two cases are proportional to θ_1 and θ_2 , and the capacity of the electrometer (*C*) must be added to that of A, we have as before the relation,

$$\frac{C_b}{C_a + C} = \frac{\theta_1 - \theta_2}{\theta_2}.$$

C may be found by charging A and the electrometer and noting the deflection θ_3 . The electrometer is then insulated, discharged, and again connected to A and the deflection θ_4 noted.

The charge which passed from A to the electrometer being *q*,

$$q = C_a(V_3 - V_4) = CV_4$$

$$\frac{C}{C_a} = \frac{V_3 - V_4}{V_4} = \frac{\theta_3 - \theta_4}{\theta_4}.$$

If *C* is very small, the experiment does not give an accurate determination, owing to the smallness of $\theta_3 - \theta_4$; but it should be noted that the smaller that *C* is, the less is the importance of knowing its value accurately.

If one of the capacities, say *C_a*, be very small in comparison with the other, it may be charged a number of times from the other, provided that it is discharged between the successive chargings. When *C_a* is first connected to *C_b* the charge remaining on *C_b* is $Q \frac{C_b}{C_a + C_b}$, where *Q* is the initial charge upon *C_b*. If *C_a* be then discharged and again connected to *C_b*, the charge upon the latter falls to

$$Q \left(\frac{C_b}{C_a + C_b} \right) \left(\frac{C_b}{C_a + C_b} \right) = Q \left(\frac{C_b}{C_a + C_b} \right)^2.$$

For *n* charges and discharges, the charge upon *C_b* falls to

$$Q \left(\frac{C_b}{C_a + C_b} \right)^n,$$

and the potential falls proportionately. Thus, if *V₁* is the initial potential of *C_b*, and *V_n* the potential after *n* sharings—

$$\frac{V_n}{V_1} = \left(\frac{C_b}{C_a + C_b} \right)^n.$$

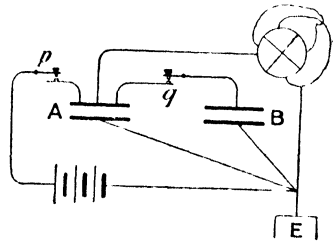

FIG. 175.

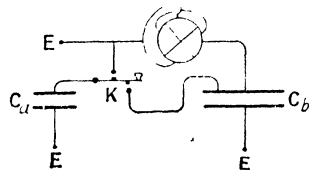

FIG. 176.

V_n and V , being proportional to the electrometer deflections and C_b and n being known, C_a may be calculated. Fig. 176 shows how the repeated sharing may be performed by means of the key K .

Kelvin's Methods.—The following null method of comparing capacities is due to Lord Kelvin. Four condensers are required, of which one must be variable, and these are arranged as in Fig. 177, the points A and B being joined to some source of electromotive force. Then if the points E and F remain at the same potential, the electrometer needle will be undisturbed, but if not there will be a deflection. If a balance is not obtained, the capacity of the variable condenser is altered and the experiment repeated. When a balance is reached the p.d. between A and E , i.e. $\frac{q_1}{C_1}$, is equal to that between

A and F , i.e. $\frac{q_2}{C_3}$.

Similarly,

∴ from the two equations,

$$\begin{aligned} \therefore \frac{q_1}{C_1} &= \frac{q_2}{C_3} \\ \frac{q_1}{C_2} &= \frac{q_2}{C_4} \\ \frac{C_1}{C_2} &= \frac{C_3}{C_4} \end{aligned}$$

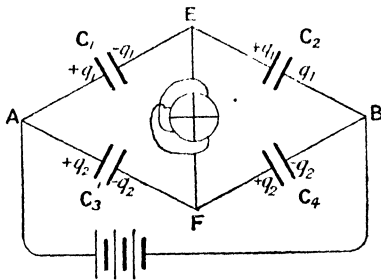

FIG. 177.

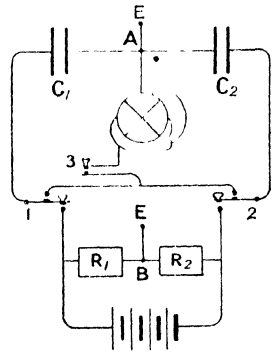

FIG. 178.

A second null method, also due to Lord Kelvin, is frequently employed for comparing capacities, and it has the great advantage over the previous method, that only one standard condenser is required, and this a constant one, the balancing being effected by varying the resistances in two boxes, R_1 and R_2 (Fig. 178). When the keys 1 and 2 are depressed, the condenser C_1 is charged by the p.d. between the ends of the resistance R_1 , the value of which is iR_1 , where i is the current produced by the battery in the circuit R_1R_2 , A and B

being earthed. Hence the positive and negative plates of C_1 have charges $+iR_1C_1$ and $-iR_1C_1$ respectively.

Similarly, the charges on C_2 are $+iR_2C_2$ and $-iR_2C_2$. On releasing the keys, the positive plate of C_1 is connected to the negative plate of C_2 , and the charge $+i(R_1C_1 - R_2C_2)$ will remain. If, now, the key 3 be closed, there will be a deflection unless the remaining charge is zero, in which case $R_1C_1 = R_2C_2$. The test is made with various resistances R_1 and R_2 , until this condition is fulfilled. This is known as the method of mixtures, and the electrometer may be replaced by a sensitive galvanometer, in which case a transient current flows on closing the key 3, when the balance is not perfect.

Gott's Method.—This is a modification of the last. On closing the key 1, D and F (Fig. 179) will in general have different potentials, and on closing key 2, a deflection will be produced. If, however, the resistances be adjusted so that there is no deflection, the p.d. between B and D is equal to that between B and F. If, then, E is the p.d. between B and earth

$$\text{p.d. between B and F} = E \cdot \frac{R_2}{R_1 + R_2}$$

$$\text{p.d. between B and D} = \frac{1}{C_2} \cdot \frac{E}{\frac{1}{C_1} + \frac{1}{C_2}}$$

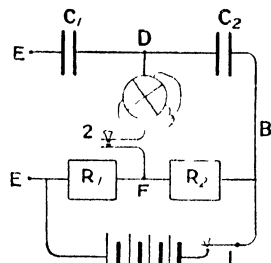

FIG. 179.

since $\frac{1}{C_1} + \frac{1}{C_2}$ is the reciprocal of the combined capacity of the condensers in series, and $\frac{E}{\frac{1}{C_1} + \frac{1}{C_2}}$ is therefore the charge on each plate of the condensers (see p. 153).

$$E \frac{R_2}{R_1 + R_2} = \frac{1}{C_2} \cdot \frac{E}{\frac{1}{C_1} + \frac{1}{C_2}}$$

$$\begin{aligned} R_2 &= C_1 \\ R_1 + R_2 &= C_1 + C_2 \\ \therefore R_1C_1 &= R_2C_2 \end{aligned}$$

Further methods for measuring capacities will be described in Chapter XIV.

Determination of Dielectric Constant.—The dielectric constant of several solid substances was measured by Boltzmann¹ in 1873 by

¹ L. Boltzmann, *Wien Akad Sitzungsber.*, 67, (2), p. 17. 1873.

a method somewhat resembling that of Faraday. A parallel plate condenser is used, between the plates of which could be inserted a slab of the substance. The capacity is compared with that of the electrometer and a fixed condenser together, by means of the method of sharing the charges, both with air between the plates, and when the slab together with an air space separates the plates. In the latter case one plate of the condenser could be moved away from the other until the capacity is restored to

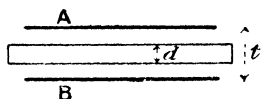

its original amount, and the dielectric constant is then known in terms of the thickness of the slab and the displacement of the plate. Thus, if t be the distance apart of the plates and d the thickness of the slab (Fig. 180), N being the electric induction, which is uniform (see p. 154), since the field is everywhere normal to the slab; the electric intensity in the air space being E , that in the slab is $\frac{E}{k}$, and if V_a and V_b are the potentials of A and B,

$$\begin{aligned} V_a - V_b &= E(t - d) + \frac{E}{k}d \\ &= E\left(t - d + \frac{d}{k}\right). \end{aligned}$$

$$\text{But, } E = 4\pi\sigma,$$

where σ is surface density of charge on plates,

$$\therefore \text{capacity per unit area of plate} = \frac{\sigma}{4\pi\sigma\left(t - d + \frac{d}{k}\right)},$$

$$\text{and, capacity of area } A = \frac{A}{4\pi\left\{t - d\left(1 - \frac{1}{k}\right)\right\}}.$$

Thus the effect of introducing the slab of thickness d , is the same as would be produced by diminishing t by the amount $d\left(1 - \frac{1}{k}\right)$, without introducing the slab, so that if t be increased by this amount when the slab is in, the capacity will again be brought to the value it had without the slab. Calling this displacement h ,

$$\begin{aligned} h &= d\left(1 - \frac{1}{k}\right), \\ \text{or, } k &= \frac{d}{d - h}. \end{aligned}$$

The values of k found for sulphur, ebonite, and paraffin were respectively 3.84, 3.15, and 2.32.

The attracted disc electrometer may be used to measure the quantity h of the last equation. As in Fig. 169, we see that the force per square centimetre of A is $\frac{E^2}{8\pi}$, and the total force $F = \frac{AE^2}{8\pi}$,

$$\text{But, } E = \frac{V_a - V_b}{t - d\left(1 - \frac{1}{k}\right)},$$

$$\therefore F = \frac{A}{8\pi} \left\{ \frac{V_a - V_b}{t - d\left(1 - \frac{1}{k}\right)} \right\}^2,$$

$$\text{or, } V_a - V_b = \left\{ t - d\left(1 - \frac{1}{k}\right) \right\} \sqrt{\frac{8\pi F}{A}}.$$

Thus, if the p.d. between the plates is maintained constant and the slab introduced, F increases and the charged plate is pulled down. On then lowering the earthed plate by the amount $h = d\left(1 - \frac{1}{k}\right)$ the charged plate will return to its original position.

Electric Absorption.—The earlier measurements of the dielectric constant were all subject to error, owing to the fact that media other than gases do not instantaneously acquire their maximum induction in an electric field. This phenomenon of "*Electric Absorption*" is very similar to that exhibited by various complex substances, such as glass, when subjected to torsional strain.¹ It was noticed by Faraday in conducting his experiment with the spherical condensers (p. 162), that a smaller result is obtained for k when the condenser containing the shellac is charged first and its charge shared with the other, than when the condenser without the shellac is charged first, and the change in the value of k obtained is greater the longer the interval that elapses between the charging of the shellac condenser and the sharing of the charges.

If a Leyden jar be given a charge and its potential be measured by means of an electrometer, it will be found that the potential will fall for some time, but will eventually become constant. On discharging the jar the whole induction in the medium does not disappear immediately; successive discharges, gradually getting smaller, may be obtained. The charge, which does not disappear at the first discharge, has been called the *residual charge*.

This phenomenon renders it important that in making measurements of the dielectric constant, the time for which the charging takes place, and the interval between charge and discharge should be known. In most cases the result obtained on charging and discharging a condenser within half a second is sufficiently constant to be used in defining the capacity of a condenser for practical purposes.

¹ See "Properties of Matter," by Poynting and Thomson.

Hopkinson's Method.—Dr. J. Hopkinson¹ used a modification of the method of mixtures for finding the capacity of a guard-ring condenser, and employing the slab method (p. 166) found the dielectric constant of various substances. The charging battery (Fig. 181) is earthed at its middle point and the terminals connected to the plate A of the guard-ring condenser and the inner cylinder D of the sliding condenser. These are consequently at equal and opposite potentials, and if the two capacities are equal, the charges received are equal

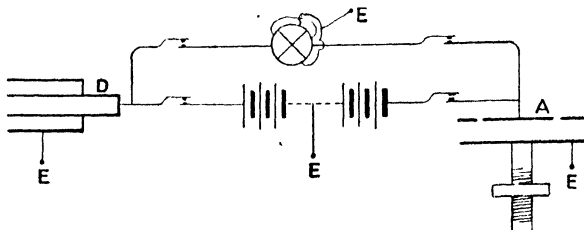

FIG. 181.

and opposite. On disconnecting the battery and joining A and D, the resulting potential as indicated by the quadrant electrometer will be zero. The sliding condenser is adjusted until this condition is fulfilled. The slab is now introduced between A and B, and the equality re-established by means of the sliding condenser, the change in capacity being therefore known. A special key is used to enable the various connections to be made with great rapidity.

As a result of an extended series of experiments, Hopkinson found that the dielectric constant for glass is constant for times of discharge varying from $\frac{1}{200000}$ to $\frac{1}{4}$ second, for measuring which short periods he used a pendulum for connecting A and D at a known short interval after the charging.

By a modification of the sharing of charges method (p. 162) Hopkinson,² using the pendulum make and break, also determined the dielectric constant of certain liquids (Table, p. 171).

Silow's Method.—A method differing entirely from the last has been employed by Silow³ for determining the dielectric constant of certain liquids. The liquid is made to replace the air in a cylindrical electrometer. The conductors A and B (Fig. 182) are four strips of tinfoil attached to the sides of a cylindrical glass vessel. The needle C is also cylindrical and is made of platinum. It is suspended by a fibre, its deflection being observed in the ordinary way. One pair of conductors, say B, is earthed, the other pair, A, being maintained

¹ J. Hopkinson, *Phil. Trans.*, **169**, p. 17. 1878.

² *Ibid.*, **172**, p. 355. 1881.

³ P. Silow, *Pogg. Ann.*, **156**, p. 389. 1875.

at steady potential, C also being earthed. The deflection is then proportional to the dielectric constant of the liquid filling the vessel. For, the capacity of a condenser being proportional to k , we may introduce this quantity into our calculation for the deflection of the needle of the quadrant electrometer (p. 159), and we then find that, when used idiostatically

$$\theta = \frac{kr^2}{2\pi ct}(V_a - V_b)^2,$$

that is, the deflection is proportional to k .

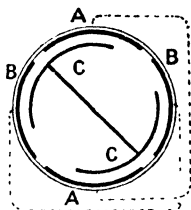

FIG. 182.

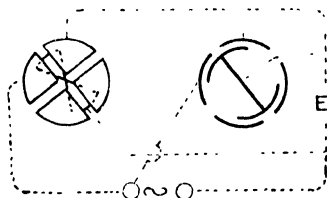

FIG. 183.

Cohn and Arons.—Using a modification of Silow's method, Cohn and Arons¹ employed an alternating p.d. for the determination of the dielectric constants of a number of liquids.

An ordinary quadrant electrometer and one constructed on Silow's principle to take the liquid, are connected, as shown in Fig. 183. The two electrometers are used idiostatically and are connected in parallel, the p.d. being supplied from an alternating source. Since they are in parallel the p.d. is at every instant the same for the two, and therefore from the equation on p. 159, $\theta = K'(V_a - V_b)^2$, the deflections when both electrometers have air as dielectric are given by,

$$\begin{aligned}\theta_1 &= K_1'(V_a - V_b)^2, \\ \theta_2 &= K_2'(V_a - V_b)^2.\end{aligned}$$

K_1' and K_2' being the values of $\frac{r^2}{2\pi ct}$ for the electrometers. Since $V_a - V_b$ is the same at every instant for the two,

$$\frac{\theta_1}{\theta_2} = \frac{K_1'}{K_2'},$$

however V_a and V_b may vary. If, now, the liquid be introduced into the Silow electrometer, and two new deflections, θ_1' and θ_2' , are simultaneously obtained—

¹ E. Cohn and L. Arons, *Wied. Ann.*, **33**, p. 13. 1888.

$$\frac{\theta_1'}{\theta_2'} = \frac{K_1'}{kK_2'}$$

$$\therefore k = \frac{\theta_2'}{\theta_1'} \cdot \theta_1$$

Landolt and Jahn¹ also employed the last method to determine k for a number of liquids. The method has the advantage that extremely rapid charging and discharging is used, so that the absorption effect is negligible.

Dielectric Constant of Gases.—The dielectric constant in the case of gases has been determined by Boltzmann,² and also by Ayrton and Perry,³ in both cases the change in capacity produced in a condenser, when the pressure of the gas is altered being found. The methods employed are modified forms of the method of mixtures.

It is found that the change in dielectric constant for a gas is very nearly proportional to the change in pressure, and thus, taking the value of k for a vacuum as unity, we have for a gas at any pressure p ,

$$k = 1 + \frac{mp}{76},$$

m being a constant.

Thus the value of k at a pressure of 76 cms. of mercury at 0° C. is $1 + m$. Change of temperature does not directly alter the dielectric constant of gases, but may, through changing the pressure, affect it indirectly.

The relation between temperature and dielectric constant has been investigated by Cassie,⁴ using the two-electrometers method, and he found that for carbon bisulphide there is a decrease of 0.0040 per cent. per degree Centigrade rise in temperature. For glycerine the value is 0.0057, for olive oil 0.0029, and for paraffin oil 0.0024, the change being in the same direction in all these cases. In the case of glass at 30° there is an increase of 0.2 per cent. per degree rise, for mica 0.04, and ebonite 0.07.

Further methods of measuring capacities will be found on p. 257, and of determining the dielectric constant for high frequency oscillations in Chapter XIV.

¹ H. Landolt u. H. Jahn, *Zeitschr. f. phys. Chem.*, **10**, p. 289. 1892.

² L. Boltzmann, *Wien. Akad. Sitzungsber.* (2), **69** p. 795. 1874.

³ W. E. Ayrton and J. Perry, *Asiatic Soc. of Japan*, April 18, 1877.

⁴ W. Cassie, *Proc. Roy. Soc. Lond.*, **46**, p. 357. 1889.

DIELECTRIC CONSTANTS (*k*).

Substance.	<i>k</i> .	Observer.
Ordinary glass	8.45	Hopkinson (<i>Phil. Trans.</i> , 169 , 17, 1878; and 172 , 385, 1881).
Plate glass	4.67	Lecher (<i>Wied. Ann.</i> , 42 , 1891).
Crown glass	6.96	Hopkinson.
Flint glass	6.61—9.096	Hopkinson.
Ebonite	3.15	Boltzmann (<i>Wien. Ber.</i> (2), 66 , 1, 1872; 67 , 17, 1873).
Sulphur (amorphous)	3.84	Boltzmann.
Mica	6.64	Klemencic (<i>Wien. Ber.</i> , 2 , 96, 1887).
Paraffin	2.32	Boltzmann.
	2.29	Hopkinson.
Shellac	3.10	Winkelmann { <i>Wied. Ann.</i> , 38 , 1889. " " 40 , 1890.
Rock salt	18	Hopkinson.
Petroleum	1.92—2.10	Hopkinson.
	2.054	Silow (<i>Pogg. Ann.</i> , 156, 1885).
	2.04	Cohn and Arons (<i>Wied. Ann.</i> , 33 , 24, 1888).
Ethyl alcohol	26.5	Cohn and Arons.
Ether	4.75—4.95	Hopkinson.
Water	76	Cohn and Arons.
	80	Nernst (<i>Zeitschr. f. phys. Chem.</i> , 14 , 1894).
	80.6	Drude (<i>Zeitschr. f. phys. Chem.</i> , 23 , 1897).
Air (76 cms. pressure)	1.000590	Boltzmann.
	1.001500	Ayrton and Perry.
	1.000586	Klemencic.
Hydrogen (76 cms. pressure)	1.000264	Boltzmann.
	1.001300	Ayrton and Perry.
	1.000264	Klemencic.
Carbon dioxide	1.000946	Boltzmann.
	1.002300	Ayrton and Perry.
	1.000984	Klemencic.

CHAPTER VII

ELECTROLYSIS

Ionic Charge.—In Chapter III. we considered Faraday's laws of electrolysis, and saw that the amount of an ion liberated from a solution by an electric current, is proportional to the strength of the current and to the time for which it flows; from this we may now conclude that the amount of the ion liberated is proportional to the amount of electricity which has passed through the electrolyte, since the current itself is the amount of electric charge passing per second. Taking the ampere as the unit of current, the corresponding unit of charge is called the coulomb, and is the amount of charge passing when one ampere flows for one second. We can then define the electro-chemical equivalent of a substance as the amount liberated by the passage of one coulomb—in fact, Faraday's first law of electrolysis is usually stated to be, "that the amount of deposition is proportional to the quantity of electricity which has passed through the electrolyte."

The second law of Faraday, from this point of view, states that a given quantity of electricity passing through the electrolyte liberates an amount of substance proportional to its chemical equivalent, and it follows, that the amount of a monovalent ion liberated is proportional to its atomic weight, of a divalent ion to half the atomic weight, and so on. Thus 107·88 grammes of silver, 35·46 grammes of chlorine, 62 grammes of NO_3 , 31·78 grammes of copper, etc., are each liberated by the same amount of electricity passing through the cell. This amount may conveniently be taken as a unit of quantity of the substance, and is called a *Gramme-equivalent*. Thus a gramme-equivalent of any monovalent substance is a quantity which, measured in grammes, is numerically equal to the atomic weight, and of a divalent substance to half the atomic weight, etc. The importance of this, lies in the fact that a gramme-equivalent of any substance is liberated by the passage of a fixed amount of electricity through the electrolyte. This amount of electricity may easily be found from the electro-chemical equivalent, for it is the amount deposited by the passage of one coulomb; therefore, taking the electro-chemical equivalent of silver to be 0·0011183 and the atomic weight 107·88—

Charge required to pass in order to liberate one gramme-equivalent of silver = $\frac{107.88}{0.0011183} = 96,467$ or 96,470 coulombs.

Since the gramme-equivalent of all monovalent substances contains the same number of atoms, we see that the liberation of each atom from the electrolyte requires the same amount of charge, and again, since the gramme-equivalent of a divalent element has half this number of atoms, all divalent substances require twice this amount of charge for the liberation of an atom.

These facts strongly suggest that the atoms are the carriers of the charges, and that a monovalent atom carries a constant amount of electricity, whatever be its chemical nature, a divalent atom twice that amount, a trivalent atom three times that amount and so on, and further, that the metallic atoms being liberated at the kathode, have a positive charge, and the non-metallic atoms or radicles, since they are liberated at the anode, have a negative charge.

Conduction.—So far we have not made any assumption as to the mechanism of the transport of the atoms with their respective charges from the solution to the electrode, but it becomes of the greatest importance to decide whether the positively and negatively charged atoms forming a molecule of the substance in solution are pulled apart on the application of the electrical field which produces the current, or whether they are wandering about independently of each other in the solution, and are merely subjected to forces, just as any other charged bodies would be, which drive the positively charged atoms down the grade of potential and those negatively charged up the grade of potential.

In future we shall speak of an atom with its associated charge as an ion; thus in an electrolyte the positive ions are liberated in the neighbourhood of the kathode, and these, on giving up their charges to the electrode, acquire the properties of neutral chemical atoms.

Experience shows that a definite amount of energy must be expended in order to effect the separation of the two ions forming a binary molecule, which energy reappears, usually in the form of heat, upon their recombination. Hence, if the ions in an electrolyte are all in a state of combination to form neutral molecules, we should expect that a certain minimum potential difference would be necessary before any decomposition would occur. But, on the contrary, it is found that any potential difference, however small, will cause *some* current to flow, although the current will soon cease unless the potential difference between the electrodes exceeds a certain amount; about 1.7 volt in the case of acidulated water. From this it might at first sight be concluded that there are a few unattached ions in the electrolyte, and that when all these have been driven to the electrodes the current ceases.

Polarisation.—The real cause of the stoppage of the current, however, is to be sought in the layer of ions which collects upon the electrodes,

which layer produces an electromotive force in opposition to that driving the current. The phenomenon is called *polarisation*, and it may be exhibited by immersing two platinum plates in a dilute solution of sulphuric acid, and passing the current by depressing the key K (Fig. 184). On releasing the key, the battery is disconnected, and the galvanometer connected to the plates, when it will be found that a current will flow for a short time. The deposition of hydrogen ions upon the kathode *k* and oxygen upon the anode *a* produces a back electromotive force, and a reverse current flows when the battery is removed and the circuit completed. This back electromotive force causes the re-

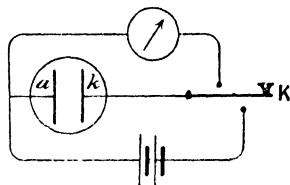

FIG. 184.

verse current to flow until the collected hydrogen and oxygen ions have been removed.

We should expect on general grounds, that some minimum electromotive force would be required to decompose any substance continuously; for in order to decompose one gramme-molecule of a substance such as water (in this case 18 grams) energy is required to separate the hydrogen and oxygen ions, the amount of which (68,400 calories per gramme-molecule) may be determined by finding the energy liberated in the form of heat on allowing them to combine. When one gramme-molecule of water is decomposed, two gramme-equivalents of hydrogen are liberated, and therefore $2 \times 96,470$ coulombs have passed through the electrolyte. If this passage is caused by an electromotive force equal to E volts, $2 \times 96,470 \times E$ joules, is the amount of work done, and this must be at least as great as the amount of energy liberated when a gramme-molecule of water is formed. Thus, if no other work is performed by the electromotive force in the cell,

$$2 \times 96,494 \times 0.239 \times E = 68,400,$$

from which $E = 1.48$ volts, and we cannot think that a less electromotive force can continuously decompose water; for, if this were the case, we could derive more energy from the liberated hydrogen and oxygen by the process of combustion than was used in separating them, and, by a suitable mechanism, we should then have an inexhaustible supply of energy, which contradicts our experience. The actual back electromotive force, opposing the current when platinum plates are used as described above, is about 1.7 volts, but in this case the surface is too small to absorb the gases as quickly as they are liberated, and bubbles are formed, some of the energy being thus irrecoverable. If, however, the surface of the electrodes is increased by depositing platinum black upon them, the minimum electro-

motive force required to produce a continuous current has been found by Le Blanc¹ to be 1.67 volts.

If, instead of water, a substance such as copper sulphate had been decomposed, copper electrodes being used, we have seen (p. 68) that the amount of copper sulphate in the solution is unchanged, and in this case we find that, however small the electromotive force may be, the current is proportional to it, that is, there is no minimum electromotive force required to produce electrolysis. In any case in which the nature of the electrode is unchanged by the deposition, there is no polarisation and no back electromotive force.

It appears then that there must be at least a few free ions in the solution, since a small but limited current flows, however small the potential difference between the electrodes. According to the experiments of Kohlrausch, who investigated the relation between the electromotive force and the current in electrolytes very thoroughly, we find that any excess of electromotive force over that necessary to balance the back electromotive force due to polarisation, produces a current strictly proportional to this excess, and hence, that Ohm's law is applicable to the conduction in electrolytes. Thus $i = \frac{E - E_1}{R}$ where E is the applied E.M.F., and E_1 the back E.M.F. due to polarisation.

Electrolytic Dissociation.—It is to Arrhenius² that we owe a satisfactory account of the process of conduction in electrolytes. According to him, the current is entirely due to the motion of the ions in the electric field between the electrodes, and it follows that the conductivity of a solution is proportional to the number of free ions present. Thus, in the case of a solution of silver nitrate, the salt, on being dissolved, dissociates to a certain extent, and free silver ions carrying a positive charge (Ag^+) and NO_3^- ions having a negative charge (NO_3^-) are formed by the splitting up of the $AgNO_3$ molecules.

It is found that the conductivity of a solution diminishes on diluting it, as would be expected if the conductivity is due to the dissolved substance, for if we imagine the solution to be diluted until a given amount of dissolved substance occupies twice the original volume of solution, there will be only half the number of ions between two fixed electrodes, that is, there will only be half the number of carriers of electricity. Provided that the velocity of the ions in constant electrical field is unchanged by the act of dilution, the same electromotive force will now produce only half the transfer of electric charge in a given time, that is, half the current, so that the conductivity is now only half its value previous to dilution. Thus, if no fresh ions are produced by dilution, we should expect the conductivity to be inversely proportional to the dilution, or directly proportional to the concentration, of the dissolved

¹ M. Le Blanc, *Zeitschr. phys. Chem.*, **8**, p. 299. 1891.

² S. Arrhenius, *Zeitschr. phys. Chem.*, **1**, p. 631. 1887.

substance, the concentration being for convenience taken as the number of gramme-molecules in one litre of solution.

Measurement shows, however, that the decrease in conductivity on dilution is not so great as the above simple argument would indicate; that is, the conductivity after dilution is greater than the simple proportion would give, and it therefore seems probable that, on increasing the dilution, new ions are produced by the dissociation of previously neutral molecules.

In order to follow this process, it is convenient to consider the change in the quantity $\frac{\text{conductivity}}{\text{concentration}}$ for a given solution. This new quantity is called the *Equivalent Conductivity* of the solution, and it is constant so long as the degree of dissociation is unchanged. As the solution is made more dilute, the equivalent conductivity of most of the solutions of inorganic salts in water increases, but the increase does not go on indefinitely, since a condition will eventually be reached in which all the molecules are dissociated, and hence the equivalent conductivity tends towards a superior limit for infinite dilution.

According then to Arrhenius' theory of electrolytic dissociation, the conductivity of a solution is proportional to the concentration of the free ions, and is therefore a measure of the degree of dissociation, γ , the ratio of the number of dissociated molecules to the total number. Thus, if λ_c be the equivalent conductivity of a solution at concentration c , and λ_∞ that at zero concentration, that is, infinite dilution,

$$\gamma = \frac{\lambda_c}{\lambda_\infty}.$$

For most substances, the actual conductivity gets so small before infinite dilution is reached that λ_∞ cannot be determined by direct measurement;

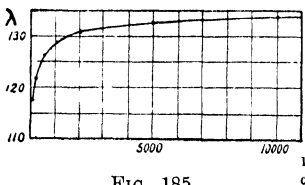

FIG. 185.

but for strongly dissociated substances in solution, such as the inorganic salts, it may be obtained without large error by extrapolation as shown in Fig. 185 for potassium sulphate. It may, however, be obtained for less strongly dissociated substances from a knowledge of the partial conductivities

of the constituent ions, as we shall see on p. 184.

The following table of molecular conductivities for the temperature 18°C . is taken from Arrhenius¹ :—

¹ Svante Arrhenius, "Lehrbook der Elektro-chemie."

c in gramme-equivalents per litre.	Dilution = $\frac{1}{c}$.	NaCl λ	KCl λ	$\frac{1}{2}$ K ₂ O ₆ λ
	∞	108.99	130.10	135.0
0.0001	10000	108.10	129.07	133.5
0.0002	5000	107.82	128.77	132.7
0.0005	2000	107.18	128.11	130.8
0.001	1000	106.49	127.34	129.0
0.002	500	105.55	126.31	126.3
0.005	200	103.78	124.41	121.9
0.01	100	101.95	122.43	117.4
0.02	50	99.62	119.96	111.8
0.05	20	95.71	115.75	102.5
0.1	10	92.02	112.03	95.9
0.2	5	87.73	107.96	88.9
0.5	2	80.94	102.41	78.7
1.0	1	74.35	98.27	71.8

This theory of electrolytic dissociation presents many difficulties, as, for example, the presence of free ions, such as the sodium ions, in a water solution of sodium chloride, since it is a well-known fact that metallic sodium and water cannot exist in contact without chemical action taking place. But it must be remembered that an ion, that is an atom with its associated charge, is in an entirely different condition to the atom without the charge, and that if sodium be liberated by electrolysis, it is dissolved by the water as soon as it has given up its positive charge to the cathode. There is no necessity for the ions to be imagined to be isolated in the solution; in fact it is extremely likely that they are surrounded by a number of neutral molecules of the solvent, which group is dragged along by the force on the enclosed ion due to the electric field. It must also be remembered that electrolytic dissociation differs fundamentally from the dissociation that is met with at high temperatures, in which case neutral molecules are formed by the splitting up of the more complicated molecule. The difference may be illustrated in the case of ammonium chloride, which dissociates at high temperatures into ammonia and hydrochloric acid.

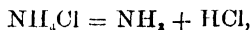

both the new molecules being uncharged or neutral molecules.

On solution in water, ammonium chloride dissociates electrolytically, thus—



Then, again, it has been advanced in opposition to the theory, that unless the positive and negative ions have the same velocity, the more rapidly moving ones would diffuse at greater rapidity, leaving the solution with a charge of electricity, and a separation in the ions might thus be effected. This objection has been met by Nernst, who

used this very fact to explain the electromotive force in cells constructed of two solutions of the same material at different concentrations.

Evidence from Osmotic Pressure.—There is, however, ample evidence from other than electrical sources to support the theory of electrolytic dissociation. Van't Hoff, making use of the discovery of Pfeffer, that a substance in solution exerts a pressure on the boundary of the solution, and that this pressure is proportional in many cases to the concentration of the solute, showed that this "osmotic" pressure is also proportional to the absolute temperature, and therefore obeys the same laws as a perfect gas. From this it follows that the maximum vapour pressure of water vapour over a solution¹ is less than over pure water by an amount proportional to the number of molecules per litre present in the solution, and hence there is a lowering of the freezing point and a raising of the boiling point, also proportional to the concentration of molecules of the solute. By measuring the lowering of the freezing point and raising of the boiling point, on the addition of a known mass of the solute, the molecular weight may be determined. In many cases the result is in accordance with that of the ordinary methods, as, for example, in the case of sugar and similar organic substances, but for those substances which in solution form electrolytes, the pressure appears to be too great, and the molecular weight therefore too small. At great dilution, the molecular weight has, in the class of substances which dissociate into two ions, half the ordinary value, which makes it seem that there are twice the expected number of molecules present, and it is not unreasonable to suppose that in these cases the substance is completely dissociated.

When dissociation is not complete, let γ be the degree of dissociation, and n the number of ions produced by the dissociation of one molecule. Then for one gramme-molecule present per litre we have $n\gamma$ dissociated ions, and $1 - \gamma$ undissociated molecules, so that the concentration, counting all together, is

$$1 - \gamma + n\gamma = 1 + (n - 1)\gamma = i.$$

This is the quantity which may be determined from the freezing or boiling point experiment, and in any given case, knowing n , γ may be found. For a number of substances, the value of γ found in this way agrees very well with that found from electrolytic determinations, ($\gamma = \frac{\lambda_c}{\lambda_\infty}$), which is very strong evidence in favour of the theory of electrolytic dissociation.

In the last three columns of the following table, the values of i in the above equation are given,² from the three methods of observation:—

¹ J. H. van't Hoff, *Zeitschr. phys. Chem.*, **1**, 481. 1887.

² J. H. van't Hoff and L. Th. Reicher, *Zeitschr. phys. Chem.*, **3**, 198. 1889.

	Concentration.	i lowering of freezing point.	i from osmotic pressure.	i from electrical conductivity
KCl	0.14	—	1.81	1.86
LiCl	0.13	1.94	1.92	1.81
Ca(NO ₃) ₂	0.18	2.47	2.48	2.46
MgCl ₂	0.19	2.68	2.79	2.48
CaCl ₂	0.184	2.67	2.78	2.42

Migration of the Ions.—According to the above theory, the free ions in solution experience forces due to the electric field in which they are situated, and hence acquire a velocity, the positive ions moving towards the kathode and the negative ions towards the anode. Except on the first application of the field, the ions will not have an acceleration, since in their motion they will encounter so many neutral molecules that their velocity will soon reach a limit; just as very small falling bodies soon reach a limiting velocity owing to the viscous resistance of the air. In the case of the ions, the limiting velocity depends in the first place upon the intensity of the electric field and the charge upon the ion, but it also depends upon the nature of the solvent and upon the size of the ion with its accompanying group of neutral molecules. Since this last varies for different ions, we should expect that their velocities in equal electric fields would be different, and Hittorf explained the variation in concentration of the solute at the anode and kathode which usually occurs, in terms of this difference in the velocity of the positive and negative ion, and even succeeded in determining the ratios of the velocities of migration of the two ions in a number of cases.¹

This variation in concentration may easily be observed in the case of the electrolysis of a solution of copper sulphate using copper electrodes, the colour of the solution becoming lighter near the kathode, since the SO₄⁻ ions have a greater velocity than the Cu⁺ ions. To observe the effect it is advantageous to use horizontal electrodes one above the other, the upper one being the kathode, with which arrangement the phenomenon is not masked by convection currents set up by the variations in density in the different parts of the cell.

The diagram given by Hittorf is a very convenient one for explaining the effect of the migration of the ions upon the changes in concentration occurring in an electrolyte. Let the dots represent positive and the circles negative ions (Fig. 186). At the instant of application of the electric field, the uniform arrangement of the two sets is indicated by the first row. Then, if the positive ions be imagined to have, for simplicity, twice the velocity of the negative ions, the state of affairs an instant later will be represented by the

¹ W. Hittorf, *Pogg. Ann.*, 89, 98, 103, 106. 1853-1859.

middle row. The deposition at the kathode is 3 ions and at the anode 3, and 7 molecules remain in solution, but of these 4 are in the

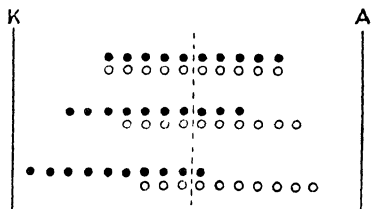

Fig. 186.

kathode half of the cell and 3 in the anode half. The third row represents the cell still another instant later, and it will be seen that the total deposition at each electrode is now represented by 6 ions and that 4 molecules remain, 3 in the kathode half and 1 in the anode half. Thus at each step it will be seen that the loss in concentration of solute

on the anode side of the median line is twice as great as that on the kathode side. In this simple case we can see that—

$$\frac{\text{Diminution in concentration at anode}}{\text{Diminution in concentration at kathode}} = \frac{\text{velocity of } + \text{ ions}}{\text{velocity of } - \text{ ions}}$$

Or in general, if u be the velocity of the positive ions and v that of the negative ions, the current and therefore the total deposition in a given time are proportional to $(u + v)$. Let the current flow for such a time that $(u + v)$ gramme-molecules of solute are removed from the solution. Now, considering the space near the kathode $(u + v)$ gramme-atoms of positive ions have been removed by deposition and u gained by migration, leaving a loss of

$$(u + v) - u = v.$$

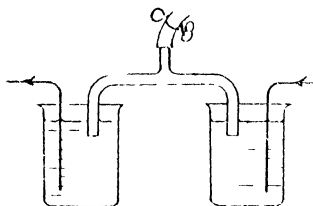

Fig. 187.

Also v gramme-atoms of negative ions are lost by migration, which shows that this part of the solution is uncharged, as it should be, and since it has lost v gramme-atoms of both kinds of ions it has lost v gramme-molecules of the solute. Similarly, on the anode side, total loss of negative ions

by deposition is $(u + v)$ gramme-atoms, and gain by migration is v , leaving a balance of u gramme-atoms lost. Also, loss in positive ions by migration is u gramme-atoms, and therefore resulting loss is u gramme-molecules of solute.

Hence we obtain Hittorf's relation—

$$\frac{\text{Loss in concentration at kathode}}{\text{Loss in concentration at anode}} = \frac{v}{u}.$$

To determine experimentally the ratio $\frac{v}{u}$, or the quantity $\frac{v}{u+v}$, which is the *transport ratio* or *migration constant* of Hittorf, changes in concentration of the solute in the neighbourhood of the kathode and anode may be found by chemical means. Two beakers (Fig. 187) contain the solution, whose concentration at the start is uniform. They

are connected electrically by a small syphon containing the electrolyte and through which the diffusion of the solute tending to equalise the concentrations in the two vessels will take place so slowly, that a determination by chemical analysis of the amount of solvent removed from each vessel for the passage of a given current may be used to measure $\frac{v}{u}$.

By this and similar methods, which must be suitably modified when one of the ions is soluble in water, the values of $\frac{v}{u + v}$ given in the table on p. 186 have been found.

Ionic Velocities.- A further step, due to Kohlrausch,¹ enables us to determine the sum of the actual velocities u and v in terms of the conductivity of the solution and the concentration of the solute. Let us take a case in which there are m gramme equivalents of completely dissociated molecules per cubic centimetre of the solution; then the concentration of both positive and negative ions is m gramme-equivalents per cubic centimetre. Now each gramme-equivalent of positive ions carries 96,470 coulombs, and if the velocity of these ions is u , the charge passing unit cross-section of the cell in one second is $mu \cdot 96,470$.

Therefore, current density due to movement of positive ions is $mu \cdot 96,470$ amperes per square centimetre. Similarly, the stream of negative ions in the opposite direction constitutes a current density of $mv \cdot 96,470$ amperes per square centimetre. But the effective current is the sum of these two, since they are opposite charges moving in opposite directions.

\therefore resultant current density = $m(u + v)96,470$ amperes per square centimetre.

The same quantity may also be expressed in terms of the conductivity of the solution and the potential gradient in it. Thus the conductivity k is the inverse of the resistivity, and is the current produced in a conductor of unit cross-section and unit length, for unit potential difference between its ends: that is, it is the current density

k

ductivity of the solution and the concentration of the solute. Let us take a case in which there are m gramme equivalents of completely

The transport ratio $\frac{v}{u+v}$ being known from Hittorf's method, u and v may be separately calculated from the two equations. Further, $\frac{k}{c}$ is the quantity we have called the equivalent conductivity (p. 176) at infinite dilution, λ_{∞} , since we have obtained our relation on the assumption that dissociation is complete. Since this quantity is known from Kohlrausch's measurements of the conductivity of highly dissociated acids and salts, u and v for unit potential gradient are known. It will be seen from the table that these velocities are very small. They must not be confused with the velocity of the free ion in the solution, on account of which it exerts a pressure called the osmotic pressure on the boundary of the solution, which in the case of hydrogen ions is about 18.4×10^4 cms. per sec., the different individual ions moving indiscriminately in all directions. The velocity u is a drift of the ions towards the cathode, due to the applied electric field.

The ionic velocities increase with rising temperature.

FOR SOLUTIONS IN WATER AT 15° C.

	Partial conductivity in practical C.G.S. units.	Ionic velocity ¹ in cm. per sec. for potential of 1 volt per cm. gradient.		Partial conductivity in practical C.G.S. units.	Ionic velocity ² in cm. per sec. for potential of 1 volt per cm. gradient.
Li	33.4	0.000347	F	46.6	
Na	43.6	0.000451	Cl	65.4	0.000678
K	64.7	0.000670	Br	67.6	
Rb	68		I	66.4	0.000685
Cs	68		NO ₃	61.8	0.000640
NH ₄	64	0.000660	ClO ₃	55.0	
Ag	54.0	0.000570	IO ₃	33.9	
$\frac{1}{2}$ Zn	46.7		BrO ₃	46	
$\frac{1}{2}$ Mg	46.0		ClO ₄	64	
$\frac{1}{2}$ Ba	55.5		IO ₄	48	
$\frac{1}{2}$ Pb	61.3		$\frac{1}{2}$ CrO ₄	72	
H	318	0.003250	$\frac{1}{2}$ SO ₄	68.4	
$\frac{1}{2}$ Sr	51.7		OH	174	0.001780
$\frac{1}{2}$ Cu	47.3				
$\frac{1}{2}$ Ca	51.8				

Direct Determination of Ionic Velocity.—Several direct determinations of ionic velocities have been made, the general method of which is to follow the course of an ion by means of some chemical reaction produced by it. The results are in fair agreement with the determinations of Kohlrausch.

¹ F. Kohlrausch, "Lehrbuch der Praktischen Physik."

² Svante Arrhenius, "Lehrbuch der Elektro-chemie."

Sir Oliver Lodge¹ filled two vessels with an electrolyte, and joined the two by a horizontal tube containing a solution of some suitable material in gelatine or in solid agar-agar jelly. Using a weak solution of sulphuric acid in the vessels, and sodium chloride with phenolphthalein as an indicator in the tube: on passing the current from one vessel to the other the H^+ ions form HCl with the sodium chloride, and decolourise the phenolphthalein. The progress of the H^+ ions could thus be watched, and their velocity measured. In another experiment, using $BaCl_2$ solution in the vessels and acetic acid and silver sulphate in the gelatine, the progress of the Ba^+ ions could be observed by the precipitate of $BaSO_4$, and of the Cl^- by the precipitate of $AgCl$.

W. C. D. Whetham² used two solutions differing in density, but of the same conductivity and having one ion in common. Thus with deci-normal solutions of potassium bichromate and potassium carbonate, the K^+ ions pass in one direction, and the $Cr_2O_7^-$ and CO_3^- in the opposite direction. Since the colour of the bichromate is due to the $Cr_2O_7^-$ ions, the travel of the surface of separation of the two liquids can be observed.

B. D. Steele³ has further modified the method by avoiding the use of colouring matter, the surfaces of separation of the liquids being sufficiently well defined on account of their different refractive indices, due to the slight differences in density produced on replacing one ion by another. The applicability of the method is thus considerably extended since it is not necessary to depend upon a coloured indicator, of which there are only a few that are suitable. The salt solution under examination is placed in a **U**-tube, and is bounded at the two ends by a gelatine solution containing the indicators employed. In some of the experiments lithium chloride and sodium acetate are used, the former at the anode and the latter at the kathode. Using, for example, potassium chloride as the salt in solution the lithium and potassium ions travel in the direction of the current, the potassium chloride being converted to lithium chloride. With the ion in solution having slightly higher velocity than the indicating ion that follows it, a very clear surface of separation can be observed with suitable illumination, and its velocity is that of the more rapidly moving ion, in this case potassium. In a similar manner, at the other end of the column of solution the anions travel from the gelatine, and the chloride is converted into acetate, and the velocity of travel of the surface of separation is that of the chlorine ions. The arrangement is always such that the denser liquid lies underneath the less dense, so that the surfaces of separation are not disturbed by convection currents, and when necessary for this, the **U**-tube is of the inverted form. Precautions are taken that the specific resistance of the solution

¹ O. Lodge, *Brit. Assoc.*, Birmingham, 1886.

² W. C. D. Whetham, *Proc. Roy. Soc.*, **52**, p. 283 (1892); **58**, p. 182 (1895).

³ B. D. Steele, *Chem. Soc. Journ.*, **79**, p. 414. 1901.

shall be as nearly uniform as possible, as only then is the potential gradient throughout the solution known.

Partial or Ionic Conductivities.—On examining the equation

$$u + v = 0.01036 \frac{k}{c} \cdot E, \quad (\text{p. 181})$$

we see that for any given value of E , the quantity $\frac{k}{c}$ or λ_∞ , which may be written $\frac{u+v}{0.01036E}$, is the sum of two others, $\frac{u}{0.01036E}$ and $\frac{v}{0.01036E}$, which are called the *partial or ionic conductivities* of the two ions. In any case λ_∞ is made up of the sum of two partial conductivities whose ratio is $u : v$, and hence if λ_∞ can be measured and also the transport ratios, the partial conductivities can be found. *The partial conductivity of any ion is independent of the other ions in the solution*, and hence, if the partial conductivities of the ions in a solution are known, the equivalent conductivity at infinite dilution λ_∞ is known, since it is the sum of the partial conductivities.

Many partial conductivities are given in the table on p. 182, and from them, the limiting equivalent conductivity λ_∞ of a substance which is only partially dissociated at very great dilution may be found.

Measurement of Conductivity.—The difficulty met with in measuring the conductivity of electrolytes is due to the polarisation which generally occurs, producing a back electromotive force that cannot always be separated from the ohmic potential difference corresponding to the resistance of the electrolyte. In some cases the electromotive force due to polarisation may be eliminated by using electrodes of the material which is present in the ionic state in the solution. Thus in the case of a solution of copper sulphate, copper electrodes may be used, and a method of simple substitution, due to Horsford, employed. The tube containing the solution is placed vertically, and is provided with disc electrodes, which nearly fill the cross-section of the tube (Fig. 188). The resistance in the box R is adjusted until the galvanometer deflection is a convenient amount. The upper electrode is then pushed downwards by a measured distance l , and R is adjusted to give the same deflection as before. The resistance of the

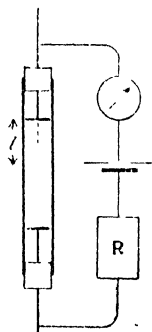

FIG. 188.

length l of the electrolyte in the tube is equal to the change of resistance in R . The mean area of cross-section of the tube may be determined by finding the weight of water required to fill a measured length of it.

The method most generally applied is due to Kohlrausch. The electrolytic cell, which has the form shown in Fig. 189 for good conductors, and Fig. 190 for bad conductors, is placed in one arm of

a slide-wire bridge, a known resistance being placed in the other. The polarisation electromotive force may be greatly reduced by using electrodes of large area, since for a given amount of deposition the layer of deposit is then thinner than when a small electrode is used. The effective area is much increased, in the case of platinum electrodes, on covering them with a layer of platinum black, by immersing them in a solution of platinum chloride, and passing a current backwards and forwards through the solution a number of times.

In order to reduce the polarisation still further, a small, and rapidly alternating current is used, so that the small amount of deposition occurring when the current passes in one direction will be removed on its reversal. A small induction coil with a high frequency trembler is

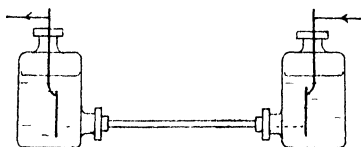

Fig. 189.

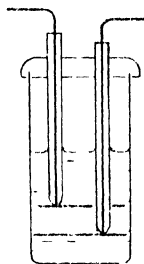

Fig. 190.

a very efficient source of electromotive force, but in this case an ordinary galvanometer is useless for finding the position of balance, since the deflection is proportional to the first power of the current and would be reversed with it; hence, there will be no deflection with an alternating current. In order to get over this difficulty, a telephone receiver is used instead of a galvanometer, and the observer adjusts the position of the slide-wire contact until a minimum of sound is heard in the telephone. Alternating current galvanometers, such as the Duddell thermo-galvanometer described on p. 80, have also been used, which instrument is capable of detecting very small alternating currents.

If resistance coils are used as standards, they should be few in number and should be wound so that they have as small an inductance and capacity as possible, as, otherwise, there will not be a perfect balance when the proportionality in resistance of the four resistances of the Wheatstone's bridge is attained. The higher the frequency of the alternating current the greater will be the disturbance due to this cause. With frequencies below 200 alternations per second the disturbance is inappreciable when ordinary resistance coils are used.

In using a cell of the type shown in Fig. 189, the cross-section of the tube may be found by means of a mercury thread whose length in the tube and whose mass are measured. The indeterminate resistance

where the end of the narrow tube enters the vessel may be eliminated by performing the experiment twice, using two different lengths of tube, cut from the same piece. As the end errors are the same for each tube, the difference in the two resistances found is equal to that of a column of length equal to the difference in length of the tubes.

If the cell have the form shown in Fig. 190, the absolute conductivity cannot be found from the dimensions of the liquid between the electrodes, with any degree of accuracy. It is usual then to find the resistance first with a standard electrolyte of known conductivity, and then with that whose conductivity it is required to find. For this purpose Kohlrausch¹ gives the conductivities shown in the following table:—

NORMAL SOLUTIONS IN WATER AT 18° C.

	$k = \frac{1}{S}$ (Ohms and c m s)	$\frac{1}{k} \frac{dk}{dt}$	$\frac{v}{u+v}$
KOH	1840 $\times 10^{-4}$	0 0186	0 74
KCl	982 6 $\times 10^{-4}$	0 0193	0 51
KBr	1030 $\times 10^{-4}$	0 0190	0 51
KI	1036 $\times 10^{-4}$	0 0190	0 51
KNO ₃	805 $\times 10^{-4}$	0 0200	0 49
$\frac{1}{2}$ K ₂ SO ₄	715 9 $\times 10^{-4}$	0 0205	0 50
NH ₄ Cl	970 $\times 10^{-4}$	0 0194	0 51
NaOH	1600 $\times 10^{-4}$	0 0197	0 83
NaCl	743 5 $\times 10^{-4}$	0 0212	0 64
NaNO ₃	659 $\times 10^{-4}$	0 0215	0 61
$\frac{1}{2}$ Na ₂ SO ₄	508 $\times 10^{-4}$	0 0236	0 64
$\frac{1}{2}$ ZnCl ₂	550 $\times 10^{-4}$	0 0220	0 70
$\frac{1}{2}$ ZnSO ₄	262 1 $\times 10^{-4}$	0 0218	0 68
$\frac{1}{2}$ CuSO ₄	257 7 $\times 10^{-4}$	0 0216	0 70
AgNO ₃	676 $\times 10^{-4}$	0 0210	0 50
HCl	3000 $\times 10^{-4}$	0 0159	0 17
HNO ₃	2990 $\times 10^{-4}$	0 0150	0 17
$\frac{1}{2}$ H ₂ SO ₄	1970 $\times 10^{-4}$	0 0120	0 17

	$k = \frac{1}{S}$ (Ohms and c m s)	$\frac{1}{k} \frac{dk}{dt}$		$k = \frac{1}{S}$	$\frac{1}{k} \frac{dk}{dt}$
KCl 5 per cent.	690 $\times 10^{-4}$	0 020	K ₂ SO ₄ 5 percent	460 $\times 10^{-4}$	0 022
" 10 "	1360 $\times 10^{-4}$	0 019	" 10 "	860 $\times 10^{-4}$	0 020
" 15 "	2020 $\times 10^{-4}$	0 018	ZnSO ₄ 5 "	191 $\times 10^{-4}$	0 022
" 20 "	2680 $\times 10^{-4}$	0 017	" 10 "	321 $\times 10^{-4}$	0 022
CuSO ₄ 5 "	189 $\times 10^{-4}$	0 022	" 15 "	415 $\times 10^{-4}$	0 023
" 10 "	320 $\times 10^{-4}$	0 022	" 20 "	470 $\times 10^{-4}$	0 024
" 15 "	421 $\times 10^{-4}$	0 023	" 25 "	480 $\times 10^{-4}$	0 026
			" 30 "	440 $\times 10^{-4}$	0 027

¹ F. Kohlrausch, "Lehrbuch der Praktischen Physik."

In all cases it is necessary to observe the temperature of the electrolyte at the time of measurement, since the resistance falls about 2.4 per cent. for a rise in temperature of one degree when the temperature is 18° C.

Application of Thermodynamics to Reversible Cells.—The second law of thermodynamics can only be applied to processes which are strictly reversible, that is to say, will proceed in either direction when one of the forces producing equilibrium is increased by an indefinitely small amount. A gas enclosed in a cylinder by means of a frictionless piston affords a good example, for if the pressure inside the cylinder exceed that outside by ever so small an amount, the piston is driven outwards, and when the pressure outside is greater than that inside by however small an amount, the piston moves inwards. If the piston is not frictionless, it requires a finite difference of pressure on the two sides to move it, and the work done in moving it in opposition to the force of friction is irrecoverable; the process is then irreversible in the thermodynamic sense.

In the case of an electric cell, we have reversibility when there is no polarisation, as in the case of a Daniell's cell, since at each electrode the ion liberated does not alter the chemical nature of the electrode, and we have already seen (p. 174) that in such a case an electromotive force, however small, will produce a current. It is also evident that if the current be allowed to flow until a certain amount of anode is dissolved and an equivalent amount of metal is deposited on the kathode, we can, on reversing the current by some external means, bring the cell back again to its original condition. This in itself is a satisfactory test for reversibility in the case of a cell.

Whenever a current flows, an amount of work $\bar{v}rt$ is converted into heat in the cell, and this is irreversible, since the process cannot be inverted; that is, the application of heat will not produce the current. Another source of irreversibility is the diffusion that takes place when there are two liquids in the cell, but we shall assume the currents and times taken, to be small enough to justify us in neglecting these two irreversible processes.

Let us then consider a reversible cell whose electromotive force is e at absolute temperature T , which can be maintained constant, and let the cell produce current until a charge q has passed round the circuit. Drawing an indicator diagram for the process (Fig. 191), PQ represents the passage of the charge q round the circuit, and this line is parallel to the axis of q , since the electromotive force is constant at constant temperature. Now thermally isolate the cell, and let a further infinitesimal charge pass; the only source of energy is now the cell

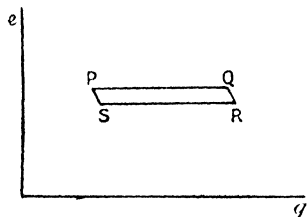

FIG. 191.

itself, and let us suppose that the using up of the energy of the cell causes drop of temperature δT . The temperature is now $T - \delta T$, and the electromotive force $e - \frac{de}{dT} \delta T$, where $\frac{de}{dT}$ is the rate of change of electromotive force with temperature. On our diagram this change is represented by the path QR. Now, maintaining the lower temperature constant, pass a current in the opposite direction to the first, until the charge q has passed through the cell; this brings us to the point S. Then pass a sufficient charge to bring the cell, when isolated thermally from outside sources, back to its original temperature T .

If all the processes are carried out by indefinitely small differences between the electromotive force of the cell and the applied external electromotive force, every part of the cycle is reversible, and the two adiabatic processes represented by QR and SP are identical and the cycle is complete.

It is shown in works on thermodynamics, that in any reversible cycle between two temperatures, the ratio of the useful work performed during the cycle to the heat drawn from the source at the higher temperature, is equal to the ratio of the difference in the two temperatures to that of the source, or

$$\frac{h - h_1}{h} = \frac{T - T_1}{T}.$$

The work done by the cell during the process PQ is eq , and that restored to the cell during the process RS is $\left(e - \frac{de}{dT} \delta T\right)q$, and if δT is so small that the difference in the amounts of work represented by the processes QR and SP is infinitesimal, the balance of useful work done by the cell is $eq - \left(e - \frac{de}{dT} \delta T\right)q = q \cdot \delta T \cdot \frac{de}{dT}$, and this is equal to

$h - h_1$, the excess of heat absorbed over that given up, so that we have from thermodynamics,

$$\frac{q \cdot \delta T \cdot \frac{de}{dT}}{h} = \frac{\delta T}{T},$$

from which,

$$h = qT \frac{de}{dT}.$$

This relation holds, whatever the chemical changes going on in the cell, since, being reversible, it is brought back to its original condition on completing the cycle, for as much charge has passed through it in one direction as in the other.

The actual heat h drawn from the source depends upon the work done, eq , and the energy supplied by the chemical reactions in the cell.

If H be the amount of heat measured in ergs, which is liberated by the chemical processes occurring when a unit of charge passes through the cell, Hq is the amount liberated during the process PQ , and the work done being eq , we have by the principle of the conservation of energy

$$eq = Hq + h,$$

that is,

$$h = eq - Hq,$$

and substituting this value of h in our previous equation we get

$$eq - Hq = qT \frac{de}{dT},$$

or,

$$e = H + T \frac{de}{dT}.$$

This is known as the equation of Helmholtz. From it we see that when the temperature coefficient $\frac{de}{dT}$ is zero, $e = H$, and the energy of the current is exactly supplied by the chemical reactions occurring in the cell. This is approximately the case in the Daniell's cell, in which case $H = 2.66 \times 4.18 \times 10^7 = 1.112 \times 10^8$ C.G.S. units, and therefore $e = 1.112$ volts. 2.66 is the number of calories liberated when one equivalent of zinc (0.00338 grammes) replaces an equivalent amount (0.00329) of copper in the sulphate. The observed electromotive force of the Daniell is about 1.09 volts.

If the electromotive force of the cell increases with rise in temperature, $\frac{de}{dT}$ is positive and $e > H$. Hence, in order to supply the energy necessary to maintain the current, the heat of the cell itself is drawn upon, and the cell is thereby cooled. On the other hand, if the electromotive force falls with rising temperature, $\frac{de}{dT}$ is negative and $e < H$. In this case the energy liberated by the chemical reaction is greater than that required by the current and the cell gets warmer when running.

Jahn¹ determined experimentally the electromotive force of a number of cells, and their temperature coefficients at a number of temperatures, also the heats of chemical reaction by means of the ice calorimeter, and found the results to be in accordance with the equation of Helmholtz.

Standard Cells.—The two most important cells used as standards of electromotive force are of the reversible type, thus ensuring constancy of electromotive force and temperature coefficient; they are the Latimer-Clark cell and the Weston or Cadmium cell. There

¹ H. Jahn, *Wied. Ann.*, 28, p. 491. 1886.

are many patterns of these cells; one very useful pattern of the Clark cell due to Lord Rayleigh is shown in Fig. 192. Through the bottom of each limb of the H-shaped tube is sealed a platinum wire to serve as terminal. Mercury is poured into one limb, and upon this rests a paste consisting of mercurous sulphate and zinc sulphate, and in the other is an amalgam of zinc (10 per cent. Zn), upon which rests a layer of crystals of zinc sulphate. Zinc sulphate solution fills the tubes above the cross-piece, and the whole is sealed up with corks and paraffin wax. According to Jager and Kahle (Reichranstalt), the electromotive force of such a cell is

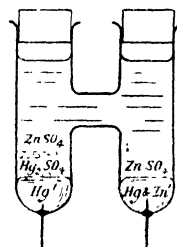

FIG. 192.

$$1.4328 - 0.00119(t - 15) - 0.000007(t - 15)^2 \text{ volt,}$$

where t is the temperature Centigrade.

In the Weston or Cadmium cell, cadmium amalgam and cadmium sulphate replace the zinc of the Clark cell, and with 10 per cent. to 13 per cent. of cadmium in the amalgam and a saturated solution of the sulphate, the value of the electromotive force of this cell, adopted by the International Conference on Electrical Units and Standards of 1908, is given as

$$1.0184 - 0.0000406(t - 20) - 0.0000095(t - 20)^2 + 0.00000001(t - 20)^3 \text{ volt.}^1$$

The Weston cell has the advantage that the temperature coefficient is much smaller than that of the Clark cell. Great care must be taken to obtain the greatest possible purity in the materials for constructing these cells, and they must be guarded against carrying more than an extremely small current. For this purpose it is convenient to connect a high resistance permanently in series with the cell.

For a detailed account of the construction of these standard cells the student should refer to "Text Book of Practical Physics," by W. Watson, or the specification prepared by F. E. Smith (Brit. Assoc., 1905, p. 98).

Concentration Cells.—The possibility of constructing cells in which the source of energy is not due to chemical action but to the diffusion occurring between two solutions of the same substance at different concentrations was first pointed out by Helmholtz.² In both the cells indicated by the formulæ

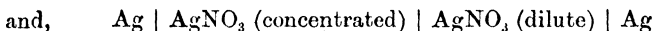
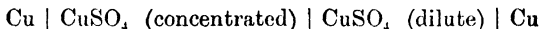

the metal in contact with the dilute solution goes into solution, and that in contact with the concentrated solution receives a deposit when

¹ The value of the E.M.F. at 20° C. now accepted is 1.0183 volt.

² H. Helmholtz, *Wied. Ann.*, 3, 201. 1878.

the cell is in action. The former is therefore the anode, and the latter the kathode.

In order to examine the mode of change of the concentration of the two solutions, let us consider that $u + v$ gramme-equivalent of metal is dissolved at the anode, and an equal quantity deposited at the kathode, where the ionic velocities of the positive and negative ions are respectively u and v . We have for the silver cell, as on p. 180—

$$\begin{aligned} \text{Loss of Ag at kathode by deposition} &= u + v, \\ \text{Gain " " " transport} &= u, \\ \therefore \text{total loss of Ag} &= (u + v) - u = v. \\ \text{Also loss of NO}_3 \text{ by transport} &= v, \\ \therefore \text{loss of AgNO}_3 &= v \text{ gramme-molecules.} \end{aligned}$$

On the other hand, at the anode we have—

$$\begin{aligned} \text{Gain of Ag by solution} &= u + v, \\ \text{Loss of Ag by transport} &= u, \\ \therefore \text{gain of Ag} &= (u + v) - u = v. \end{aligned}$$

And since there is a gain of NO_3 by transport equal to this—

$$\text{Gain in AgNO}_3 \text{ at anode} = v \text{ gramme-molecules.}$$

Thus the result of the process is a transference of v gramme-molecules of AgNO_3 from the concentrated to the dilute solution. If instead of $u + v$ gramme-atoms deposited we take one gramme-atom,

the transference of AgNO_3 is equal to $\frac{v}{u + v}$ gramme-molecules, and

$\frac{v}{u + v}$ is the transport ratio of the negative ion. Other cells have been devised in which the migration of the positive ion has been employed, and in this case the transference of the salt for one gramme-equivalent

of deposit would be $\frac{u}{u + v}$ gramme-molecules. Putting the transport

ratio $\frac{v}{u + v}$ equal to n , we see that $\frac{u}{u + v} = 1 - n$.

Source of Energy in Concentration Cells.—We may seek for the source of energy of the current in the diluting of the solution from the concentration at one electrode (C_1) to the less concentration (C_2) at the other electrode. The substance in solution exerts a pressure, the osmotic pressure, which has been shown by Pfeffer, and by van't Hoff (see p. 178) to have the same value as that exerted by an equal number of molecules existing as a gas in a space equal in volume to the solution, and hence work is done as the solute expands from molecular volume $\frac{1}{C_1}$ to molecular volume $\frac{1}{C_2}$.

The pressure of a gas is given by the relation $PV = RT$, where T is the absolute temperature, and R a constant that can be found from the volume of a given amount of gas at some standard temperature and pressure.

It is usual to take V as the reciprocal of the concentration in gramme-molecules per unit volume, so that if this be known, R will enable us to calculate the osmotic pressure P at any temperature T . If then we imagine the expansion of the solute to take place reversibly by enclosing it in a cylinder, in which works a piston constructed of a medium which is permeable to the solvent but not to the solute, so that the osmotic pressure P , may be balanced by an external pressure very slightly less than P , applied to the piston —

work for small increase dV in volume = PdV ,

$$\begin{aligned} \therefore \text{total work} &= \int_{P_1}^{P_2} PdV, \\ &= \int_{V_1}^{V_2} \frac{RT}{V} dV, \\ &= RT[\log_e V]_{V_1}^{V_2}, \\ &= RT \log_e \frac{V_2}{V_1}, \end{aligned}$$

or remembering that,

$$V_1 = \frac{1}{C_1}, \text{ and, } V_2 = \frac{1}{C_2},$$

$$\text{work} = RT \log_e \frac{C_1}{C_2}.$$

Such semi-permeable membranes have only been found for a few substances, but the actual work done by the solute in expanding so that the solution becomes more dilute, does not depend upon the mechanical method of carrying out the dilution, provided that the process is reversible, which it is in the case of the concentration cell; for the solute may be carried back from the weak to the strong part of the solution on reversing the current by means of some external electromotive force.

E.M.F. of Concentration Cells.—Now, work performed in producing current = eq ergs, where q is the charge in absolute units (9647), equivalent to the transference of one gramme-equivalent of ion, and as there is no other source of energy than the work done by the solute in changing from concentration C_1 to concentration C_2 , and remembering that when the solute is completely dissociated, the osmotic pressure is double that for no dissociation, by Avogadro's law—

$$\text{Work} = 2RT \log_e \frac{C_1}{C_2}$$

and therefore, for n gramme-equivalents of solute transferred by the passage of the above charge, we may write

$$eq = 2nRT \log_e \frac{C_1}{C_2}$$

Taking the density of hydrogen as 0.0000899 gramme per cubic centimetre at 0° , and the atmospheric pressure of $76 \times 980.6 \times 13.59$ dynes per square centimetre, the molecular weight being 2.016, the molecular volume (V) is $\frac{2.016}{0.0000899}$, and since $PV = RT$ —

$$76 \times 980.6 \times 13.59 \times \frac{2.016}{0.0000899} = RT,$$

from which,

$$R = 8.32 \times 10^7.$$

And remembering that $\log \frac{C_1}{C_2} = 2.303 \log_{10} \frac{C_1}{C_2}$, we have—

$$e = \frac{8.32 \times 10^7 \times 2.303 \times 2}{9647} nT \log_{10} \frac{C_1}{C_2}$$

And at 18°C. , $T = 291$,

$$\therefore e = 5.78 \times 2n \log_{10} \frac{C_1}{C_2} \times 10^6,$$

$$E = 0.0578 \times 2n \log_{10} \frac{C_1}{C_2} \text{ volts.}$$

Thus the electromotive force of a concentration cell consisting of two solutions is proportional to the absolute temperature, and depends upon the ratio only of the concentrations. In the silver nitrate cell suggested above, $n = \frac{61.8}{54 + 61.8} = 0.533$ (see table on p. 182), and at temperature 18°C. , with ratio of concentrations 10 : 1,

$$E = 0.0578 \times 2 \times 0.533 = 0.0615 \text{ volt.}$$

The value found by Nernst is 0.055 volt at 18°C. , and the discrepancy between this and the calculated value, he attributed to the incomplete dissociation of the salt in solution.

Since there is no resultant chemical reaction in the concentration cell, the total amount of solute remaining constant, and all the processes are reversible, we may apply Helmholtz's E.M.F. equation—

putting $H = 0$,

$$\text{then, } e = T \frac{de}{dT},$$

$$\text{or, } \frac{de}{e} = \frac{dT}{T}.$$

And integrating—

$$\log_e e = \log_e T + \text{constant},$$

$$\log_e \frac{e}{T} = \text{constant},$$

or e is proportional to T , which is in accordance with the relation found.

Amalgam Concentration Cells.—Another form of concentration cell in which the electrodes are amalgams, the two having different concentrations of the metal, and the electrolyte being a solution of some salt of the metal, was constructed by G. Meyer.¹ The electromotive force acts in such a direction that the metal is transferred from the amalgam of greater to that of less concentration, and since it has been shown that the osmotic pressure of the metal in an amalgam is proportional to the concentration, the electromotive force may be calculated as above. For cells with amalgams of Zn, Cd, Pb, Sn, Cu, and Na, there was agreement between the calculated and the observed electromotive forces.

Now the expression for the work done by a gas or a solute in expanding, namely

$$\int_{P_1}^{P_2} P dV, \text{ or, } \int_{V_1}^{V_2} \frac{RT}{V} dV \quad (\text{p. 192})$$

depends upon the value of P , or of $\frac{RT}{V}$.

and the value of the gas constant R is calculated on the assumption that the molecule is undissociated; but it follows that when dissociation occurs, the pressure increases in accordance with Avogadro's rule, that at equal temperatures and pressures, equal volumes contain equal numbers of molecules. Hence if each molecule dissociates into n others, on going into solution $P = n \frac{RT}{V}$.

And the expression for the work done on expansion, becomes

$$\int_{V_1}^{V_2} \frac{nRT}{V} dV = nRT \log_e \frac{V_2}{V_1},$$

or since $PV = \text{constant}$, at constant temperature—

$$\text{work} = nRT \log_e \frac{P_1}{P_2}$$

¹ G Meyer, *Zeitschr. Phys. Chem*, 7, 477. 1891.

and the value of the electromotive force at the contact of the concentrated amalgam with the solution is given by

$$e_{qr} = nRT \log_e \frac{P_1}{P_2},$$

where qr is the quantity of electricity which passes from the concentrated amalgam to the solution for one gramme-atom of the metal to be transferred, which is $9647r$ absolute C.G.S. units; r being the valency.

$$\therefore e = \frac{nRT}{9647r} \log_e \frac{P_1}{P_2},$$

P_1 and P_2 being the osmotic pressures of the metal in the amalgam, and in the solution respectively.

Similarly, at the electrode of weaker amalgam—

$$e = \frac{nRT}{9647r} \log_e \frac{P_3}{P_2},$$

where P_3 is the osmotic pressure in this amalgam, and the electromotive force acts from the amalgam to the solution. The resulting electromotive force due to the whole cell is therefore the difference between these two;

$$i.e. \quad \frac{nRT}{9647r} \log_e \frac{P_1}{P_3}.$$

The results of Meyer's experiments agree with those calculated on the assumption that the molecular weight of the metal in the amalgam is equal to its atomic weight, the osmotic pressure being proportional to the concentration.

A further type of concentration cell may be employed, namely, one in which a gas, such as hydrogen, is dissolved, or rather occluded by platinum or palladium. On immersion in a solution of sulphuric acid there is an electromotive force between the electrode and the solution, owing to the difference in osmotic pressure between the occluded gas in the electrode and the ions in the solution. Wulf¹ has shown that up to pressures of 1000 atmospheres, the observed and the calculated electromotive forces are in agreement.

Solution Pressure.—The consideration of the relation between osmotic pressure and electromotive force, particularly in the case of amalgams, enabled Nernst to make a great step forward in the theory of the voltaic cell. Ever since its discovery by Volta there had been a controversy regarding the location of the electromotive force in the circuit. While, on one hand, Volta and his followers maintained the junction of the metals to be the seat of the electromotive force; on

¹ T. Wulf, *Zeitschr. f. phys. Chem.*, **48**, p. 87. 1904.

the other hand, Davy looked to the contact of the metal and the solution, and explained the electromotive force in terms of the chemical affinity of the metal for the acid in solution. The experiment of the electrification of a copper and a zinc disc when placed in contact and then separated, seemed to bear out Volta's contact hypothesis, but this effect was explained by the chemical school of physicists on the ground of the difference in chemical affinity of copper and zinc for the oxygen of the air.

Following the experimental work on concentration cells, Nernst¹ explained the electromotive force in terms of the work done by the ions in travelling from places of higher to places of lower concentration, on account of the osmotic pressure exerted by them. When a metal is placed in a solution, the osmotic pressure of the ions in solution drives the ions upon the metal, but the ions in the metal itself having a certain pressure tending to drive them into solution, there will be equilibrium when these two pressures are equal.

Thus for every metal there is a particular osmotic pressure of the metallic ions in solution, for which neither deposition nor dissolving will occur. This is called the solution pressure of the metal for the given solvent. From the reasoning given above for concentration cells, it follows that the electromotive force at the contact of a metal with its solution is

$$e = \frac{RT}{r9647} \log_e \frac{P}{p} \text{ absolute units,}$$

where r is the valency of the metal, P the solution pressure, and p the osmotic pressure of the ion in solution.

The electromotive force directed from a metal to the normal solution of its salt has been determined by Ostwald, the values being for —

Mg	+ 1.22 volt.	Pb,	- 0.10 volt.
Zn,	+ 0.51 "	H,	- 0.25 "
Al,	+ 0.22 "	Cu,	- 0.60 "
Cd,	+ 0.19 "	Hg,	- 0.99 "
Fe,	+ 0.06 "	Ag,	- 1.01 "

From the last equation, we may find the solution pressure P for the metal, if we take p to be the osmotic pressure due to the metallic ions in the normal solution. In the case of hydrogen, taking two atoms to the molecule in the gaseous state, and the density 0.0899 gramme per litre at 0° C., and the atmospheric pressure, for a normal solution of 1 gramme per litre the pressure is $\frac{2}{0.0899}$ atmospheres at 0° C., from van't Hoff's law (p. 178), taking the molecules to be monatomic.

¹ W. Nernst, *Zeitschr. Phys. Chem.* 4, 129. 1889.

Hence the electromotive force between hydrogen (H_2) occluded by palladium and a solution containing 1 gramme of hydrogen per litre being -0.25 volt, or -0.25×10^8 absolute units,

$$-0.25 \times 10^8 = \frac{8.32 \times 10^7 \times 273}{1 \times 9647} \log_e \frac{P}{p}$$

from which, $\log_e \frac{P}{p} = -10.74$, and, $\frac{P}{p} = 2.16 \times 10^{-5}$

$$\therefore P = \frac{2 \times 2.16 \times 10^{-5}}{0.0899} = 4.8 \times 10^{-4} \text{ atmosphere.}$$

The following are the approximate values of the solution pressures in atmospheres:—

Mg, 10^{44} atmospheres.	Pb, 10^{-2} atmospheres.
Zn, 10^{18} "	H, 10^{-4} "
Al, 10^{13} "	Cu, 10^{-12} "
Cd, 10^7 "	Hg, 10^{-15} "
Fe, 10^3 "	Ag, 10^{-18} "

The electromotive force of a reversible cell may then be represented in terms of the solution pressures of the electrodes and the osmotic pressures of the ions in solution; thus, in the case of the Daniel cell, neglecting the electromotive force due to the contact of the solutions, which is very small compared with that due to the electrodes—

$$e = \frac{RT}{2 \times 9647} \log_e \frac{P}{p} - \frac{RT}{2 \times 9647} \log_e \frac{P'}{p'}$$

where P and P' are the solution pressures of zinc and copper, p and p' being the osmotic pressures of the zinc and copper ions in the solutions; and, taking the e.m.f. from zinc to solution as 0.51 volt, and from solution to copper to be -0.60 (table, p. 196), the e.m.f. of the cell would be 1.11 volt.

Dropping Electrodes.—At the moment of bringing a metal into contact with a solution, a transference of ions will take place in accordance with the respective osmotic and solution pressures. If the circuit is not completed through some other electrode, this transference of the ions will produce an electromotive force at the contact of the metal and the solution, which will increase as the transference of ions continues, until a limit is reached, at which further transference is prevented. Thus, in the case of mercury in contact with a solution of sulphuric acid, it will be seen from the table of solution pressures, that the mercury ions in the solution will pass to the jet (Fig. 193), since the solution pressure of the mercury is extremely small, and is less than that for even a very weak solution. The mercury will then become charged positively with respect to the solution. This electromotive force will, however, require an appreciable time for its establishment,

and it was pointed out by Helmholtz, that if the mercury issue from a small orifice in the form of a jet into the solution, it will break up into drops before any appreciable potential difference is produced, and the jet will then be at the same potential as the solution. Although the explanation of the production of the p.d. given by Helmholtz differs from the above, the fact of the usefulness of the dropping electrode remains.

It will easily be seen that any attempt to measure the electromotive force at a single contact between a metal and an electrolyte is frustrated by the necessity of making electrical connection with the electrolyte by means of a second metallic electrode, and the measurement gives us merely the algebraic sum of the two respective electromotive forces between the metals and the solution, unless we can obtain some electrode at which there is no electromotive force at its contact with the solution. The dropping electrode of Helmholtz supplies us with such a terminal, but the observations made with it were very unreliable until Paschen¹ constructed a form of it in which the mercury jet does not enter the liquid until it is just about to break up, the interval of time in which the mercury is in contact with the solution before breaking into drops being then a minimum. In Fig. 193, the leads 1 and 2 go to the mercury of the jet and the pool of mercury in the vessel. On measuring the difference of potential between 1 and 2, we thus obtain that between the mercury at rest in the pool at the bottom and the solution.

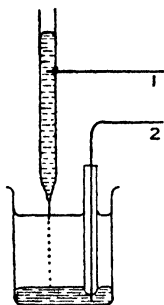

FIG. 193.

ing difference of

potential, produced by combining this with other electrodes, can be found by the ordinary means.

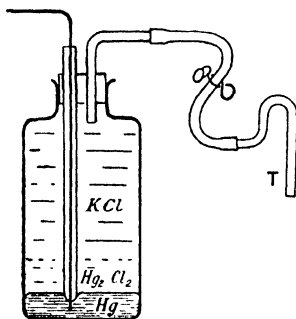

FIG. 194.

Normal Electrode.—It is convenient to employ some constant form of electrode of useful pattern and known electromotive force, to combine with other electrodes whose electromotive force it is required to find. This usually consists of mercury upon which rests a layer of mercurous chloride, and again upon this a normal solution of potassium chloride, which fills the remainder of the vessel and the tube T. The latter can be placed in any cell in which the electromotive force at contact with the electrode

¹ F. Paschen, *Wied. Ann.*, 41, p. 42. 1890.

and the solution is required. The resultant electromotive force being measured in the ordinary way, that of the normal electrode may be deducted and the unknown electromotive force obtained.

The electromotive force of the normal electrode is 0.56 volt, the mercury being positive to the solution.

Capillary Electrometers.—An alternative method of measuring the electromotive force at the contact of mercury and a dilute solution of sulphuric acid has been devised by Lippmann.¹ We have seen that the electromotive force is so directed that the mercury is positive with

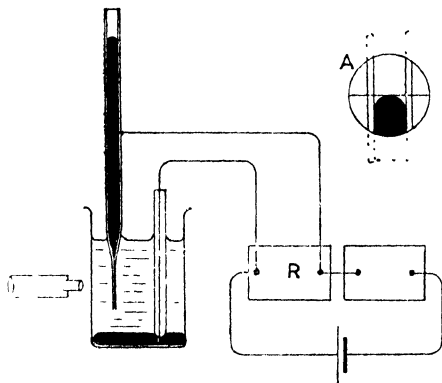

FIG. 195.

respect to the solution. Now it is found that the surface tension of the mercury in contact with the solution depends upon this electromotive force, and becomes a maximum when this is zero. If, then, the difference of potential between the mercury and the solution be varied by any means and in either direction, the surface tension diminishes.

The mercury in a long tube (Fig. 195) will not flow through the capillary part at the lower end, unless the pressure of the mercury exceeds a certain amount, depending upon the surface tension of the mercury and the diameter of the tube, and since the drawn-out end of the tube tapers slightly, there will be an equilibrium position of the mercury meniscus for each value of the surface tension. The pressure of the mercury may be adjusted by varying the height of the column, by means of an arrangement not shown in the diagram, until the meniscus is in the field of the microscope, as shown at A. For an increase in the surface tension the meniscus will rise, while for a decrease it will sink, and its position may therefore be adjusted by varying the resistance in the box R and therefore the difference of potential between the mercury in the capillary tube and that in the beaker. This difference of potential is adjusted until the meniscus reaches its

¹ G. Lippmann, *Ann. Chim. Phys.*, V. 5, p. 494. 1875.

highest point, or rather lowest, as seen inverted in the field of vision of the microscope, as at A, when the dilute sulphuric acid and the mercury in the capillary tube will be at the same potential. The potential difference as measured by the current in the resistance box R, is equal to the electromotive force that exists between the mercury and the solution in the beaker.

A very convenient form of capillary electrometer is shown in Fig. 196. The capillary tube is of uniform bore and is nearly horizontal. Its lower portion contains mercury and its upper portion, together with the vessel, contains dilute sulphuric acid. The left-hand terminal is naturally positive to the solution, and if this difference of potential

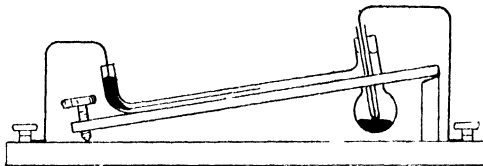

FIG. 196.

be diminished, the surface tension of the mercury surface in contact with the solution is increased, and the meniscus travels down the tube, reaching a limiting position when this difference of potential vanishes. If the difference of potential be further changed in the same direction, the meniscus travels back again. The sensitiveness of this electrometer may be increased by making the inclination of the tube to the horizontal less, by means of the screw, and by reading the position of the meniscus by means of a microscope.

Changes of p.d. of the order of 0.001 volt may be detected by means of this apparatus.

Secondary Cells or Accumulators.—Any form of reversible cell may be used as an accumulator, for if a current be sent through it in a direction opposite to that produced by the action of the cell itself, deposition takes place at the natural anode, and the natural cathode is dissolved. Thus energy is stored in the cell, and may be liberated by allowing the cell to produce current until the original condition is regained. Very little advantage, however, is obtained by using the cell in this way, as in most cases it is easier and cheaper to provide new electrodes rather than to produce them electrolytically by a reversed current.

A very convenient form of accumulator was produced by Planté in 1859. He placed lead electrodes in a 15 to 30 per cent. solution of sulphuric acid, and passed a current through the cell. The hydrogen liberated at the cathode bubbles away, but the oxygen liberated at the anode oxidises the lead to form PbO_2 . On removing the external source of electromotive force and joining the lead electrodes, a current

passes, the oxidised plate being kathode, the liberated hydrogen reducing the lead oxide, and the oxygen at the other electrode oxidising the lead. This current flows until both plates arrive at the same state of oxidation.

If now a current be caused to flow through the cell, one plate is further oxidised and the oxide upon the other is reduced to metallic lead. This lead is in a spongy form, and it is found that if the current be sent through the cell repeatedly in opposite directions, the layer of spongy lead gets thicker and thicker, the storage capacity of the cell at the same time increasing. This process of repeated reversals of the current to increase the storage capacity of the cell is called "forming" the plates.

The electromotive force of such a cell when fully charged is about 2.1 volts, and from its construction, its internal resistance is very small, so that considerable currents may be obtained by means of it. Moreover, the voltage remains nearly constant throughout the greater part of the discharge. A cell of seven plates is shown in plan and elevation in Fig. 197. The plates have very great surface and are close together, being separated by distance pieces consisting of lengths of glass tube.

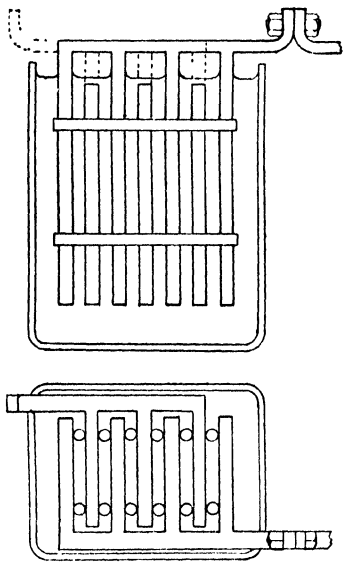
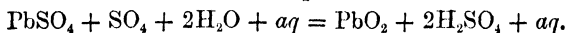

FIG. 197.

The plate which is oxidised when fully charged is called the positive plate, and the reduced plate the negative. In the figure, the three plates would be positive and the four negative.

The process of charging may be represented as follows:—

Positive plate.



Negative plate.

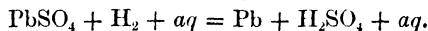

For discharge we have—

Positive plate.

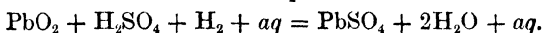

Negative plate.

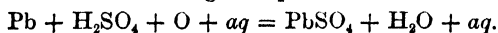

Thus during charge the electrolyte gains sulphuric acid and its density rises, while during the discharge the reverse takes place. In fact, the density of the solution is the most convenient index of the condition of the cell; when fully charged it should not be above 1.21, and the discharge should never be continued until the density falls below 1.17, since insoluble lead sulphate is then formed. As this is not again reducible, the cell is ruined; it is technically said to be "sulphated." The PbSO_4 of the above equations is very different to the insoluble lead sulphate usually met with in the laboratory, and the equations themselves are very rough approximations to the actual processes.

Faure Cell.—The process of "forming" the plates of the Planté cell is a long and therefore costly one, and it was therefore suggested by Faure that the plates should be constructed of lead grids, into which a mixture of several oxides of lead is compressed. This plate takes much less time to "form," but it is not so durable as the plate "formed" by electrolysis. Many cells of both kinds are on the market, and some in which the positives are Planté or "formed" plates, and the negatives Faure or "paste" plates.

CHAPTER VIII

THERMO-ELECTRICITY

THE study of reversible thermo-electric effects dates from the discovery by Seebeck,¹ in the year 1826, that a current flows in a circuit consisting of two different metals when a difference of temperature is maintained between the two junctions. He arranged 35 metals in a series such that, when any two comprise a circuit, the current flows across the hot junction from the metal occurring earlier to that occurring later in the series. Seebeck's list comprises Bi - Ni - Co - Pd - Pt - U - Cu - Mn - Ti - Hg - Pb - Sn - Cr - Mo - Rh - Ir - Au - Ag - Zn - W - Cd - Fe - As - Sb - Te, and several others of doubtful composition, such as brass, commercial copper, etc.

The discovery of the complementary phenomenon, the heating or cooling of a junction when a current flows across it, is due to Peltier,² who found in 1834 that on passing a current across a junction from bismuth to antimony, heat is absorbed at the junction, which is therefore cooled, but on reversing the direction of the current heat is developed, and the junction is warmed.

The Seebeck and Peltier phenomena may both be explained if we assume an electromotive force to exist at the junction of the two metals, its direction being from bismuth to antimony across the junction.

If the circuit (Fig. 198) could be completed without the introduction of any further electromotive force, a current would flow in the direction BADC, a fall of potential occurring in the external circuit from A and B. The heat is produced by the current in the

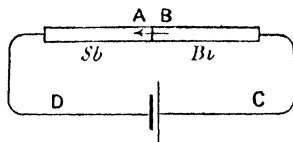

FIG. 198.

external circuit at the expense of the energy at the junction. Such a circuit, having only one junction, is impossible, and if the ends of the antimony and bismuth rods be bent round and brought into contact at a second point, the electromotive force at this junction is, of course, equal and opposite to that at the first, so that the resultant

¹ T. J. Seebeck, *Pogg. Ann.*, Bd. VI., 1826.

² Peltier, *Ann. d. Chim. et de Phys.*, 2 Serie, 56. 1834.

electromotive force in the circuit is zero, and there will be no current. If, however, a cell be introduced, so that a current is driven in the direction DCBA, it is found that the junction AB is cooled, and from our reasoning on p. 60 we should conclude that the direction of the Peltier electromotive force is from B to A. On reversing the cell, so that the current flows in the direction ABCD, the junction AB is warmed, which fact again indicates the presence of the electromotive force at the junction in the direction B-A.

On constructing a simple circuit of two metals—antimony and bismuth will do very well for our present purpose—we have seen that, owing to the opposition of the two equal electromotive forces at the junctions, there is no current. If, however, the junctions are not at the same temperature, these opposing electromotive forces are not necessarily equal; in fact, they are generally unequal, and the resultant electromotive force equal to their difference will maintain a current.

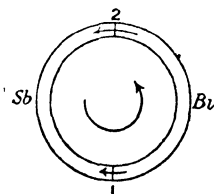

FIG. 199.

Let π_2 be the electromotive force at junction 2 (Fig. 199), at the higher temperature, and π_1 that at 1, at the lower temperature. In the case of the above metals $\pi_2 > \pi_1$, and if these are the only electromotive forces in the

circuit, the resultant E.M.F. is $\pi_2 - \pi_1$, and the current is anti-clockwise.

It will be seen that the current itself will cause a cooling at 2 and heating at 1, and we may therefore look upon the difference of temperature between the junctions as the condition for the current to flow, and further, the current flows until it has brought the circuit to uniform temperature.

It is not difficult to demonstrate the heating or cooling at an Sb-Bi junction¹ by placing a bismuth bar between two bars of

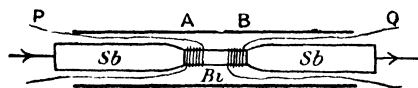

FIG. 200.

antimony, and passing a current through the three in series as in Fig. 200. Two pieces of silk-covered, fine copper wire are wound one upon each half of the rod of

bismuth; the two are connected to the two gaps of a metre bridge, and a balance found in the ordinary way. If, now, a current be passed through the rods from left to right, the junction A is warmed and B is cooled, and the two copper coils will now be at different temperatures. Since the electrical resistance of copper varies very rapidly with change of temperature, the balance of the metre bridge is now destroyed, and a galvanometer deflection will be observed, which deflection may be reversed by sending the current through

¹ *Nature*, Feb. 16, 1911.

the rods from right to left. Peltier placed the junctions in glass bulbs, and observed the heating and cooling by the expansion or contraction of the air in the bulbs; but the amount of heat developed or lost is in all cases very small, so that atmospheric disturbances of temperature are liable to hide the effect sought. He also used a thermal junction, thus employing the Seebeck phenomenon, but it is desirable if possible to use an independent heat phenomenon for demonstrating the effect.

The Peltier effect must not be confused with the Joule production of heat. The latter, for a conductor of constant resistance r , is i^2r ergs per second, and is irreversible; that is, electrical energy is always converted into heat, the reverse process being impossible. Also the heating effect is proportional to the square of the current, and is therefore independent of its sign and direction, whereas the Peltier effect varies as the first power of the current and so depends upon its direction. Thus if the current flowing one way across a junction causes a heating πi ergs per second, where π is the Peltier electromotive force, usually called the Peltier coefficient, a current in the opposite direction causes a cooling at the same rate. Owing to the fact that the heat liberated at a junction diffuses by conduction through the mass of the metals, it is not convenient to measure the Peltier effects by means of the heating or cooling due to a known current; the actual method of determination will be described later.

Measuring heat in electrical units, we have: heat developed at any junction = $\pm \pi it$, where t is the time for which the current flows, the sign depending on the direction of the current.

Laws of Addition of Thermal Electromotive Forces.—In measuring the electromotive force in any circuit due to thermo-electric effects, it is nearly always necessary to insert some piece of apparatus, such as a galvanometer, somewhere in the circuit, and since this generally involves the presence of more than the two original metallic junctions, it is important to formulate the laws according to which the electromotive forces produced by additional junctions may be added. There are two such laws.

1. *Law of Intermediate Metals.*—The insertion of an additional metal into any circuit does not alter the whole electromotive force in the circuit, provided that the additional metal is entirely at the temperature of the point of the circuit at which it is inserted.

This law may be taken as the result of experiment, but we may see that it follows from the second law of thermodynamics; for if a number of metals A, B, C, etc., are joined in series to form a complete circuit, there is no current in the circuit when the temperature is everywhere the same. Should a current flow, it will immediately cause heating or cooling at the junctions, and the energy required to maintain the current would be obtained by heating some parts of the circuit and cooling others,

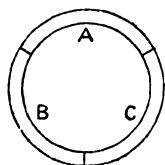

FIG. 201.

the divergence of temperature becoming greater the longer the current flows. As there is no chemical action in the circuit, the above process would be in contradiction to the second law of thermodynamics, and we therefore conclude that there is no current, and that the algebraic sum of the electromotive forces in the circuit is zero. The same reasoning would apply if C were removed, and therefore we conclude that the introduction of C when it is entirely at the temperature of the point at which it is inserted does not alter the total electromotive force in the circuit.

This is equally true though the junction between A and B, at which C is inserted should be at some other temperature, for this does not effect the electromotive force occurring at the unaltered junction of A and B, this being determined by its own temperature only.

2. *Law of Intermediate Temperatures.*—The electromotive force for a couple with junctions at T_1 and T_3 is the sum of the electromotive forces of two couples of the same metals, one with junctions at T_1 and T_2 and the other with junctions at T_2 and T_3 .

For, in Fig. 202 (α) let the electromotive force for the T_2 - T_3 couple be $[e]_2^3$ and that for the T_1 - T_2 couple be $[e]_1^2$. Then if the junctions at the temperature T_2 be placed in contact there is no change, because like metals at the same temperature only are joined, and if then the junctions be opened to form the arrangement (β) there is again no change in the resultant electromotive force, for the two contacts destroyed both had the same Peltier effect π_A^B at temperature T_2 , and these are directed oppositely in the compound circuit. We therefore conclude that

$$[e]_1^3 = [e]_1^2 + [e]_2^3.$$

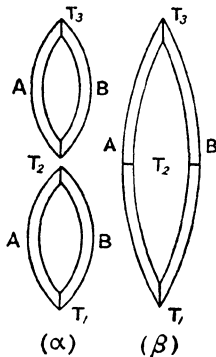

FIG. 202.

Application of Thermodynamics.—Since the Peltier effect is a reversible one, a thermal couple is an arrangement for deriving useful energy by the absorption of heat at one temperature, part of which is given back at a lower temperature, the difference in the amount absorbed and that given up being the energy applicable for external purposes. Thus the current may be used for driving an electro-motor in which case the energy takes the form of mechanical work. Although the available energy is usually very small in amount this does not vitiate our argument.

Lord Kelvin¹ pointed out that, the processes being entirely reversible, the arrangement is in reality a heat engine with source at one temperature (T_2) and refrigerator at a lower temperature (T_1), and that the ratio of the heat absorbed at temperature T_2 to that given up at

¹ W. Thomson, *Phil. Trans. Roy. Soc.*, 1855.

T_1 , should be the same as that of T_2 to T_1 , where T_2 and T_1 are absolute temperatures.

Now, on carrying a charge q round the circuit, the heat absorbed at the hot junction is $\pi_2 q$, measured in absolute units, and that given up at T_1 is $\pi_1 q$,

hence,
$$\frac{\pi_2 q}{\pi_1 q} = \frac{T_2}{T_1}, \text{ or, } \frac{\pi_2}{\pi_1} = \frac{T_2}{T_1}.$$

and therefore,
$$\frac{\pi_2 - \pi_1}{\pi_1} = \frac{T_2 - T_1}{T_1}.$$

Now, if $\pi_2 - \pi_1 = e$, the whole electromotive force in the circuit—

then,
$$e = \pi_1 \left(\frac{T_2 - T_1}{T_1} \right)$$

It would therefore follow that if one junction is maintained at constant temperature T_1 , then π_1 is constant, and $e \propto (T_2 - T_1)$. Now it may easily be shown that this is not true; for if a piece of copper and a piece of iron wire be twisted together at one end and the other ends connected to a galvanometer, it will be found on heating the copper-iron junction with a burner, that the resulting current, and therefore electromotive force, increases at first, then diminishes, and passing through zero, actually becomes reversed.

Obviously then, e is not proportional to $T_2 - T_1$.

Lord Kelvin (then Prof. Wm. Thomson) therefore concluded that the Peltier effect was not the only source of electromotive force in the circuit, and pointed out the likelihood of another, existing between the different parts of a metal at different temperatures.

If, then, for any substance, σ is the electromotive force due to unit difference of temperature between two points of it, $\int_{T_1}^{T_2} \sigma dT$ is the total electromotive force between points at temperatures T_1 and T_2 , and taking σ_a and σ_b for the value of σ in the two metals A and B in Fig. 203, our equation of electromotive forces for the whole circuit will now become

$$e = \pi_2 - \pi_1 - \int_1^2 \sigma_a dt + \int_1^2 \sigma_b dt,$$

the small arrows indicating the directions in which the various electromotive forces tend to drive the current round the circuit. σ is assumed

to be positive for both metals, that is, the electromotive force is directed from points of lower to those of higher temperature, and could the circuit be completed by a neutral conductor so that this is the only electromotive force in the circuit, the current would flow in the external circuit from points of high to points of low temperature.

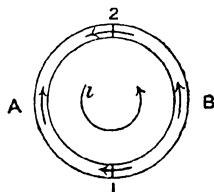

FIG. 203.

The quantity σ is called the Thomson coefficient, and the existence of the electromotive force involves an absorption of heat if a current flows in the direction of the electromotive force, since its direction is such that the electromotive force tends to maintain the current, and therefore to give energy to the circuit, which energy is supplied at the expense of the heat of the metal itself. If the current be reversed, heat is liberated for a corresponding reason (p. 60). The sign of σ may be positive or negative, which means that the Thomson electromotive force may act in such a direction that it tends to drive the current in the external part of the circuit from points of high to points of low temperature or *vice versa*. Thus, if σ is positive the state of affairs is shown in Fig. 204 (i), where the ordinates indicate the temperature, and the small arrows the Thomson electromotive force. The current passing in the direction ABC absorbs heat in AB, since it is flowing in the direction of the electromotive force; that is, from points of lower to those of higher temperature; and for a corresponding reason it gives out heat in BC, just as a flow of an ordinary liquid down a tube heated at B would do. On the other hand, if σ is negative, we have the condition shown in Fig. 204 (ii). A current

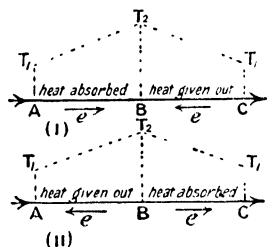

FIG. 204.

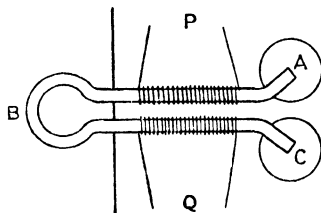

FIG. 205.

flowing from A to C would give out heat in the part AB and absorb heat in BC; that is, it gives out heat when flowing from colder to hotter points, and absorbs it when flowing from hotter to colder points, so that if we wish to find any analogy with the flow of liquid in a tube heated in the middle, we must imagine the liquid to have a negative specific heat.

σ is positive for the metals Cd, Zn, Ag, Cu, and negative for Fe, Pt, and Pd.

The Thomson effect may be exhibited¹ in a manner similar to that for the Peltier effect, but in this case the difficulty is greater, on account of the fact that a considerable temperature gradient is necessary for the exhibition of the effect, and thus it is not easy to measure the small additional reversible heating and cooling due to the current. If, however, an iron rod be bent into the shape shown in Fig. 205

¹ *Nature*, Feb. 16, 1911.

with the two limbs, on which the resistance coils P and Q are wound, very close together and packed round with asbestos wool, then if P and Q are placed in gaps of a metre bridge as before and a balance found, a current of 10 amperes flowing round ABC will cause a disturbance in the balance when B is heated to red heat with a bunsen burner, and A and C immersed in mercury baths. In this way a very steep temperature gradient in BA and BC can be maintained, and the change of resistance in P and Q, due to the current, occurs in a manner which shows that heat is given out when the current flows up the temperature gradient, and the limb in which the current flows down the temperature gradient is cooled.

The effect with copper is in the reverse direction, and is much smaller, both on account of the smallness of the Thomson coefficient σ , and the difficulty of maintaining sufficient temperature gradient owing to the high thermal conductivity of the metal.

Thermo-electric Power.—The equation of electromotive force—

$$e = \pi_2 - \pi_1 - \int_1^2 \sigma_a dT + \int_1^2 \sigma_b dT,$$

may be written in the form—

$$e = \int_1^2 \frac{d\pi}{dT} dT - \int_1^2 (\sigma_a - \sigma_b) dT,$$

$\frac{d\pi}{dT}$ being the rate of change with temperature, of the Peltier coefficient for the two metals, and π_2 and π_1 the upper and lower limits of the

integral $\int \frac{d\pi}{dT} dT$.

Or, again,

$$e = \int_1^2 \left\{ \frac{d\pi}{dT} - (\sigma_a - \sigma_b) \right\} dT.$$

Differentiating this equation with respect to T, we have—

$$\frac{de}{dT} = \frac{d\pi}{dT} - (\sigma_a - \sigma_b).$$

$\frac{de}{dT}$ is called the *Thermo-electric power* for the two metals, and is the rate of change of the electromotive force acting round a couple with change of temperature of one junction. The thermo-electric effects in a circuit may be very conveniently represented on a diagram in a manner suggested by Prof. Tait,¹ the values of $\frac{de}{dT}$, the thermo-

¹ Prof. Tait, *Proc. Roy. Soc. Edin.*, p. 597. 1871.

electric power, being plotted against the temperature. Then, at a temperature represented by the point F in Fig. 206, the thermo-electric power P is represented by EF, and the thickness of the strip being dT ,

$$\text{area of strip} = \frac{de}{dT} \cdot dT = PdT = de.$$

Hence the area of the strip represents the electromotive force acting round the couple, the difference of temperature of the junctions being dT .

By the law of intermediate temperatures, the electromotive force round a couple having junctions at temperatures represented by D and C respectively, is equal to the sum of the electromotive forces for a number of couples having differences of temperature dT , provided that the first junction has temperature corresponding to D and the last to C.

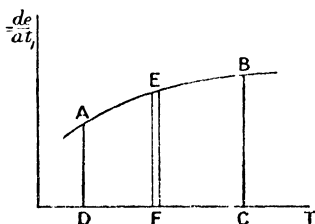

FIG. 206.

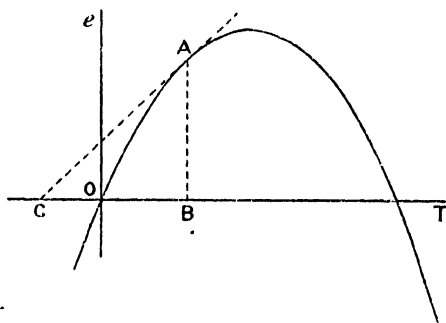

FIG. 207.

Thus, the electromotive force is equal to the sum of the areas of strips, such as EF, and this is the area of the whole figure ADCB.

The electromotive force for finite differences of temperature may be found by experiment, by measuring the total electromotive force round a circuit, when one junction is maintained at constant temperature and that of the other varied. The shape of the curve usually obtained is shown in Fig. 207, and the rate of increase of e , when the temperature of the hot junction is represented by OB is the ratio $\frac{AB}{BC}$, where AC is a tangent to the curve at the point A.

Thus,

$$\frac{de}{dT} = \frac{AB}{BC} = P,$$

and the curve (Fig. 206) may now be plotted for P, the thermo-electric power as derived from Fig. 207.

The experimental methods of measuring the electromotive force due to a couple will be considered later, but we may note that the

E.M.F.—Temperature curves for most metals approximate to parabolas, which would lead to the (thermo-electric power)-(temperature) curves being straight lines, as we shall see on p. 216.

Second Law of Thermodynamics.—In applying the second law of thermodynamics to the couple, we must now take the Thomson effect into account, since the heat is not all absorbed at the hot junction nor all given up at the cold junction. Suppose

a charge q to pass round the couple consisting of metals A and B, having its junctions at temperatures T_2 and T_1 (Fig. 208). As before (p. 207), when charge q passes round the circuit in an anti-clockwise direction in the figure, the heat absorbed at the hot junction is $q\pi_2$, and that given out at the cold junction, $q\pi_1$, that given out in passing through the metal A is $q \int_1^2 \sigma_a dt$, and that absorbed in passing through

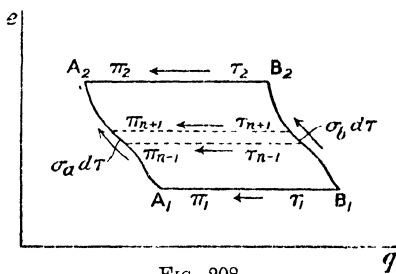

FIG. 208.

B, is $q \int_1^2 \sigma_b dt$ (see Fig. 203).

Let us consider the couple to consist of an infinitely great number of small couples at temperatures, T_{n-1} and T_{n+1} , etc., varying from T_1 to T_2 . From the law of intermediate temperatures (p. 206), the electromotive force for the whole couple is the sum of the electromotive forces for the small couples. For the small couple whose junctions are at T_{n+1} and T_{n-1} , bearing in mind the direction of the current and the fact that when this is in the direction of the Peltier or Thomson electromotive force, heat is absorbed and *vice versa*, we see from Fig. 208, that—

heat absorbed at $T_{n+1} = q\pi_{n+1}$,

heat given out at $T_{n-1} = q\pi_{n-1}$,

heat given out in metal A at mean temp. $T_n = q\sigma_a dT$,

heat absorbed in metal B at mean temp. $T_n = q\sigma_b dT$.

Since all these processes are reversible, we can apply the second law of thermodynamics to the cycle, which states that $\sum \frac{Q}{T} = 0$.

Thus, for the elementary cycle—

$$\frac{q\pi_{n+1}}{T_{n+1}} - \frac{q\pi_{n-1}}{T_{n-1}} - \frac{q\sigma_a dT}{T_n} + \frac{q\sigma_b dT}{T_n} = 0.$$

For the adjacent small cycle we have—

$$\frac{q\pi_{n-1}}{T_{n-1}} - \frac{q\pi_{n-3}}{T_{n-3}} - \frac{q\sigma_a dT}{T_{n-2}} + \frac{q\sigma_b dT}{T_{n-2}} = 0,$$

where the lower temperature for one cycle is the upper temperature for the next, and so on. Adding up these equations for all the elementary cycles, remembering that the first has upper temperature T_2 , and the last, lower temperature T_1 , the terms $\frac{q\pi_{n+1}}{T_{n+1}}$, etc., all cancel out except the first and the last.

$$\begin{aligned} \therefore \frac{q\pi_2}{T_2} - \frac{q\pi_1}{T_1} - q \int_1^2 \frac{\sigma_a dT}{T} + q \int_1^2 \frac{\sigma_b dT}{T} &= 0, \\ \text{or, } \frac{\pi_2}{T_2} - \frac{\pi_1}{T_1} - \int_1^2 \frac{\sigma_a - \sigma_b}{T} dT &= 0. \end{aligned}$$

Now $\frac{\pi_2}{T_2}$ and $\frac{\pi_1}{T_1}$ are the limits at T_1 and T_2 of the integral $\int \frac{d}{dT} \left(\frac{\pi}{T} \right) dT$,

$$\therefore \int_1^2 \frac{d}{dT} \left(\frac{\pi}{T} \right) dT - \int_1^2 \frac{\sigma_a - \sigma_b}{T} dT = 0.$$

Differentiating this, we have—

$$\begin{aligned} \frac{d}{dT} \left(\frac{\pi}{T} \right) - \frac{\sigma_a - \sigma_b}{T} &= 0. \\ \therefore \sigma_a - \sigma_b &= T \frac{d}{dT} \left(\frac{\pi}{T} \right). \end{aligned}$$

Substituting this value of $\sigma_a - \sigma_b$, which is a consequence of the application of the second law of thermodynamics, in equation—

$$\frac{de}{dT} = \frac{d\pi}{dT} - (\sigma_a - \sigma_b), \quad (\text{p. 209})$$

we have,

$$\begin{aligned} \frac{de}{dT} &= \frac{d\pi}{dT} - T \frac{d}{dT} \left(\frac{\pi}{T} \right) \\ &= \frac{d\pi}{dT} - T \left\{ \frac{1}{T} \cdot \frac{d\pi}{dT} - \frac{\pi}{T^2} \right\} \\ &= \frac{\pi}{T}. \end{aligned}$$

From which, $\pi = T \frac{de}{dT}$.

Thus the Peltier coefficient for the junction of a pair of metals is the product of the absolute temperature of the junction (T) and the rate of change of the electromotive force for the whole circuit with change of temperature of the junction $\left(\frac{de}{dT} \right)$.

Thermo-Electric Diagram.—Let us now return to the consideration of the thermo-electric diagram; we shall find that the relation

$\pi = T \frac{de}{dT}$ enables us to interpret the diagram more fully than we

could hitherto. If A_1A_2 (Fig. 209) is the line whose ordinates are the thermo-electric powers P at different temperatures, of the metal A , with respect to the metal B , the area $A_2A_1B_1B_2$ represents the electromotive force acting round the couple when the temperatures of the junctions are T_1 and T_2 , which on the diagram are

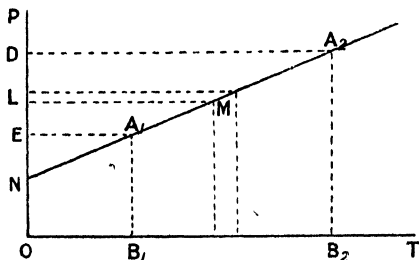

FIG. 209.

imagined to be measured from the absolute zero of temperature, the direction of the effective electromotive force round the circuit being in the order of the letters, that is anti-clockwise in the diagram.

$$\text{Now } \pi_2 = T_2 \frac{de}{dT} = T_2 P_2.$$

$$\text{But } A_2B_2 = P_2, \text{ and, } OB_2 = T_2,$$

$$\therefore \pi_2 = \text{area of rectangle } B_2A_2DO.$$

$$\text{Similarly, } \pi_1 = \text{area of rectangle } B_1A_1EO.$$

Again, from equation $\sigma_a - \sigma_b = T \frac{d}{dT} \left(\frac{\pi}{T} \right)$ on p. 212;

since,

$$\frac{\pi}{T} = \frac{de}{dT} = P,$$

$$\sigma_a - \sigma_b = T \frac{dP}{dT},$$

and,

$$(\sigma_a - \sigma_b)dT = TdP.$$

But the area of the strip LM is TdP , because $LM = T$, and width of strip = dP .

$$\therefore \int_1^2 (\sigma_a - \sigma_b)dT = \text{area } A_1A_2DE.$$

We can therefore identify all the thermal electromotive forces acting round the couple, as areas upon the diagram.

Thus,

$$\pi_2 = \text{area } B_2A_2DO,$$

$$\pi_1 = \text{area } B_1A_1EO,$$

and,

$$\int_1^2 (\sigma_a - \sigma_b)dT = \text{area } A_1A_2DE.$$

Which would, from our electromotive force equation—

$$e = \pi_2 - \pi_1 - \int_1^2 (\sigma_a - \sigma_b) dT,$$

give,

$$e = \text{area } B_2 A_2 A_1 B_1.$$

It will be seen that the Peltier and Thomson effects are electromotive forces which would drive a current from points whose positions upon the thermo-electric diagram are lower to those which are higher.

The electromotive force round a couple may be represented as a function of the thermo-electric power, or the Peltier coefficient for—

$$P_A = \frac{de}{dT} = \frac{\pi}{T}.$$

$$\therefore de = P_A dT = \left(\frac{\pi}{T}\right) dT,$$

$$\text{and, } [e]_1^2 = \int_1^2 P_A dT = \int_1^2 \left(\frac{\pi}{T}\right) dT,$$

where $[e]_1^2$ is the electromotive force acting round a couple A-B the temperatures of whose junctions are T_1 and T_2 respectively, and P_A is the thermo-electric power of A with respect to B.

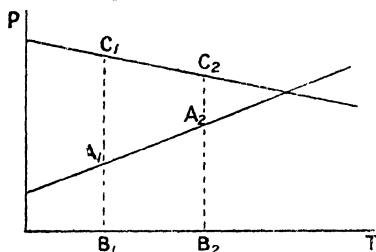

FIG. 210.

In the above reasoning one metal (B) has been taken as a standard and the thermo-electric powers of the other metal (A) plotted with respect to it. If now a third metal (C) be combined with B to form a couple, we should have an exactly similar

set of relations for C and B. Thus for temperatures of junctions T_1 and T_2 (Fig. 210)—

$$e = \text{area } C_2 C_1 B_1 B_2$$

$$\pi_2 = T_2 \cdot B_2 C_2, \text{ and, } \pi_1 = T_1 \cdot B_1 C_1, \text{ etc.,}$$

and it follows from the law of intermediate metals, that for the couple made up of A and C—

$$e = \text{area } A_1 A_2 C_2 C_1$$

$$\pi_2 = T_2 \cdot A_2 C_2, \text{ and, } \pi_1 = T_1 \cdot A_1 C_1$$

Hence if any one metal be taken as standard and the thermo-electric powers of a number of others be plotted with respect to it, the thermo-electric powers with respect to each other of the different metals will simply be the difference of the respective ordinates for the

thermo-electric lines of the two metals. And further, if it is desired to change the standard metal, all that is necessary is to replot the curves, with the differences of the ordinates measured from the new standard as ordinates upon the new diagram. This will not change the relations of the thermo-electric powers of the different metals, nor will it alter any of the areas in the diagram, and the respective electromotive forces also will be unchanged. Thus, in Fig. 210, if we subtract A_1B_1 , A_2B_2 , etc., from all the appropriate ordinates, A_1A_2 will now be horizontal, B_1B_2 will slope downwards from left to right, and the slope of C_1C_2 will be increased, but the electrical quantities involved will all be unchanged.

The metal usually taken as a standard with respect to which the thermo-electric powers of the others are plotted is lead, the reason being that the Thomson coefficient for lead is supposed to be zero,¹ but should this subsequently prove not to be the case, the usefulness of the diagram would not be affected, and we could, if we chose, knowing the value of σ for lead, replot the diagram, taking an ideal metal for which $\sigma = 0$ as standard.

If we assume that for lead $\sigma = 0$, which is certainly very nearly true, and in Fig. 209 take B to be lead, equation $\sigma_a - \sigma_b = T \frac{dP}{dT}$

becomes $\sigma_a = T \frac{dP}{dT}$, since $\sigma_b = 0$.

Thus, since T is essentially positive, the Thomson coefficient σ has the same sign as $\frac{dP}{dT}$, and if P increases with the temperature σ is positive, if P decreases with rising temperature σ is negative. It will then be seen from the diagram (Fig. 213) that for cadmium, zinc, etc., σ is positive, and for iron, palladium, etc., it is negative, and further, that since $\frac{dP}{dT} = \tan \theta$, where θ is the inclination of a thermo-electric line to the axis at any point—

$$\sigma = T \tan \theta.$$

Neutral Temperature.—So far we have made no assumption as to the shape of the thermo-electric lines; but if they are straight lines we can then calculate the electromotive force round any couple when we know the equations to the thermo-electric lines.

In Fig. 211, let $P_a = m_a T + c_a$, and $P_b = m_b T + c_b$ be the equations to the thermo-electric lines for the metals A and B. Then—

$$[e]_1^2 = \int_1^2 (P_a - P_b) dT = \int_1^2 [(m_a - m_b)T + c_a - c_b] dT,$$

¹ Le Roux, *Ann. de Chim. et de Phys.*, 4 serie, 10, p. 201. 1867.

which, when integrated gives—

$$e = \frac{1}{2}(m_a - m_b)(T_2^2 - T_1^2) + (c_a - c_b)(T_2 - T_1)$$

If the temperature T_1 be fixed while T_2 be varied, we see that the

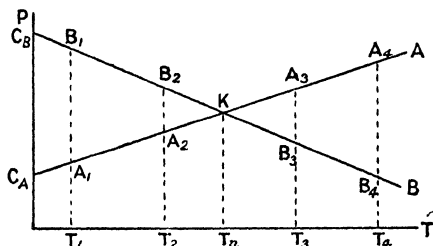

FIG. 211.

equation connecting e and T_2 is that of a parabola. It may be written in the form—

$$e = (T_2 - T_1) \left\{ \left(\frac{T_2 + T_1}{2} \right) (m_a - m_b) + (c_a - c_b) \right\}.$$

Hence e is zero when $T_2 = T_1$, which would be expected; but it again becomes zero when

$$\frac{T_2 + T_1}{2} = - \frac{c_a - c_b}{m_a - m_b}.$$

That is, when the average temperature of the junctions is $-\frac{c_a - c_b}{m_a - m_b}$.

This temperature is called the *Neutral Temperature*, and is that at which $P_a = P_b$, or the thermo-electric lines, $P_a = m_a T + c_a$, and $P_b = m_b T + c_b$, intersect. Calling it T_n , we may now write the electromotive force equation—

$$e = (m_a - m_b)(T_2 - T_1) \left\{ \frac{T_1 + T_2}{2} - T_n \right\}.$$

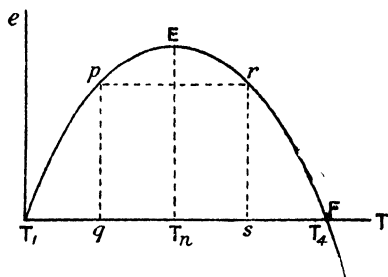

FIG. 212.

T_n is evidently the temperature corresponding to the point E (Fig. 212) on the E.M.F.-Temperature diagram at which the curve ceases to rise and begins to descend, for on referring to Fig. 211 it will be seen that with one junction at fixed temperature T_1 , the area $B_1 A_1 A_2 B_2$ which represents the electromotive force round the couple, increases as T_2 rises,

until the neutral point K is reached. When this is passed, as at temperature T_3 , the area A_3KB_3 must be deducted from the area B_3A_3K to get the effective electromotive force round the couple; for at temperatures below T the thermo-electric power of B is greater than that of A, but this is reversed when T_n is passed, the thermo-electric power of B with respect to A at T_n being zero. Below T_n the Peltier and Thomson effects have been so directed in A_1A_2 , A_2B_2 , B_2B_1 , that they tend to drive a current round the circuit from A to B across the hot junction, but at T_3 the effect in B_3A_3 is such that it tends to drive the current from B to A at the hot junction, and its value grows until a temperature T_4 is reached, which is as much above T_n as T_1 is below it, when area $A_1KB_1 = B_1A_1K$, and the resultant electromotive force round the couple is zero. This temperature corresponds to the point F in Fig. 212. The student may verify the fact that in Fig. 211—

$$\text{area } (A_1B_1 \times T_4) - \text{area} \int_1^4 \sigma_a dT + \text{area } (A_1B_1 \times T_1) - \text{area} \int_1^4 \sigma_b dT = 0.$$

If now the temperature of the hot junction be raised above T_4 the resultant electromotive force in the couple is reversed. For this reason T_n is sometimes called the temperature of inversion, as the direction of the resultant electromotive force changes sign as the average temperature of the couple passes this value.

A curve such as that shown in Fig. 212 is easy to determine experimentally, and from it the neutral temperature can be accurately found. The temperature corresponding to the highest point E can only be read approximately, since at this point the electromotive force is changing very slowly with temperature. But by taking two points p and r for which the electromotive force is the same, the mid-point between q and s is the neutral temperature T_n . If this be done for some metal A, using lead for the metal B, $\sigma_b = 0$, $m_b = 0$, and $c_b = 0$, since the thermo-electric line for B is now the temperature axis, and therefore $T_n = -\frac{c_a}{m_a}$.

Also when one junction is at the neutral temperature (say $T = T_n$), remembering that $m_b = 0$, we have, $e = \frac{1}{2}m_a(T_n - T_2)^2$, either from the diagram (Fig. 209) taking T_n as the intersection of A_1A_2 with the axis of T or by substitution in the equation for e on p. 216. Thus if the electromotive force $[e]_1^n = ET_n$ (Fig. 212), be noted from the curve, m_a can be calculated, and since $T_n = -\frac{c_a}{m_a}$, c_a can also be found, and the equation—

$$P_a = m_a T + c_a$$

for the thermo-electric line becomes known.

Referring to equation $\sigma = T \tan \theta$ (p. 215), we see that when the thermo-electric lines are straight, $\tan \theta$ is identical with m_a , which is

constant, and that σ is therefore proportional to the absolute temperature.

If it is inconvenient to compare the given metal directly with lead, the electromotive forces for a couple made up of the metal with some other which has previously been compared with lead may be found, and the electromotive forces for the metal and lead found by means of the law of intermediate metals.

Tait¹ found that for most of the metals the E.M.F.-Temperature curves are approximately parabolas, and therefore the thermo-electric lines are straight; but exceptions occur, as in the cases of iron and

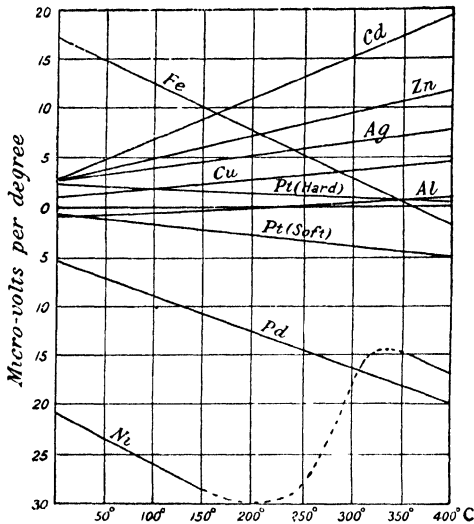

FIG. 213.

nickel, which exhibit several points of inflection at high temperatures. The thermo-electric line for iron cuts that for an alloy of platinum and iridium at several high temperatures, and it is pointed out that if an Fe-(Pt-Ir) couple have one junction at each of two temperatures at which the thermo-electric lines intersect, a current will be maintained on account of the Thomson effect alone, for the Peltier coefficients at these points are zero. The curves of Fig. 213 are taken from Prof. Tait's paper, but the thermal electromotive forces are converted from his arbitrary units (the Grove cell, E.M.F. = 1.7 volt) approximately into micro-volts.

The thermo-electric lines for iron at temperatures up to 1000° C.

¹ Prof. Tait, *Trans. Roy. Soc. Edin.*, p. 125. 1873.

have been determined by G. Belloc,¹ and these show clearly (Fig. 214) the points of inflection mentioned by Tait. The thermo-electric powers are given in micro-volts per degree, with respect to the metal platinum, which was taken for reference. The effect of various percentages of carbon in the iron, upon the thermo-electric power is also indicated by the dotted lines in the diagram. The approximate position of the thermo-electric line of silver with respect to platinum is also placed upon the same diagram, and it will be seen that if a silver-iron couple be constructed and the junctions maintained

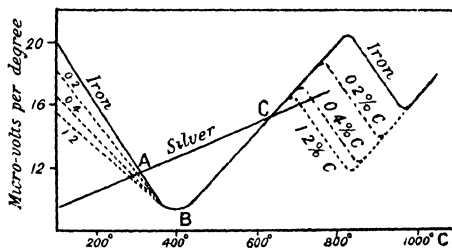

FIG. 214.

at 310° C. and 620° C. respectively, the Peltier coefficients at these temperatures are zero, and a current will then be maintained on account of the Thomson effect alone, the effective electromotive force acting round the couple being represented by the area to scale of the figure ABC.

Experimental Measurements.—The electromotive force in a thermal couple may be measured by placing a calibrated galvanometer in the circuit and observing the current. Then, knowing the resistance of the circuit, the corresponding electromotive force may be found; but a much better way is to employ the potentiometer, as in this case the current in the couple is zero when a balance is obtained. Since the electromotive force is usually of the order of a few milli-volts, the potentiometer must be modified so that it can measure much smaller E.M.F.'s than usual. A wire AB about a metre long (a metre bridge will do very well) is connected in series with a resistance box R_1 (Fig. 215), a rheostat R_2 , and a secondary cell E_1 . The resistance per centimetre of AB being known, the fall of potential in micro-volts per centimetre of it can be found when the current is adjusted by means

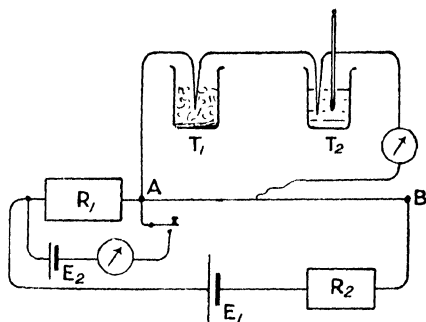

FIG. 215.

¹ G. Belloc, *Ann. de Chim. et de Phys.*, **30**, p. 42. 1903.

of R_2 , so that the potential difference between the ends of R_1 is equal to the electromotive force of the standard cell E_2 . Then, the junction T_1 being kept in ice and water, the temperature of T_2 may be varied, and the electromotive force of the couple found from the length of wire AB necessary to produce a balance.

A more convenient apparatus for the same purpose, made by the Cambridge Scientific Instrument Company, is illustrated in Fig. 216. The secondary cell B maintains a steady current in the circuit $BVSSR_2R_1B$. Using a standard cadmium cell M and N,

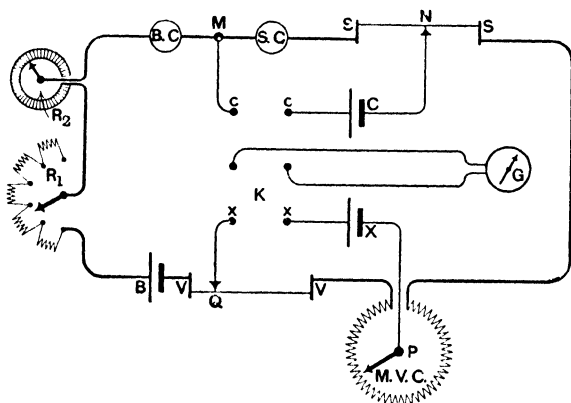

FIG. 216.

the current in the main circuit is adjusted by means of the rheostats R_1 and R_2 until a balance is obtained, and SC and SN are arranged to be of such resistance that for the proper value of the main current, the fall of potential over 50 ohms of circuit is 1 volt. The coil MVC has 29 sections, each of resistance 0.05 ohm, and the fall of potential per section is thus 1 milli-volt. VV is the slide wire upon which the final balancing is performed, and has a resistance of 0.06 ohm, so that the difference of potential between P and Q due to the current may be varied at will from 0 to 30.2 milli-volts. This is, therefore, the range of variation of the electromotive force of the thermal couple to be measured, the couple being placed at X. As the electromotive force of a thermal couple rarely exceeds 30 milli-volts, the instrument is a very convenient one for rapidly calibrating such couples.

If a number of points on the E.M.F.-Temperature curve be obtained with one junction at fixed temperature, and the other variable, the apparatus forms a convenient pyrometer for measurements of temperature over considerable range.

Applications to Thermometry.—The electromotive force in a thermal couple, although very small, has, as a rule, a circuit of very

low resistance in which to produce a current, which may therefore be considerable. One of the best-known applications, is the detection of small amounts of radiant heat by means of the *Thermopile*. The effect produced by one junction is multiplied by arranging a number in series. Antimony and bismuth bars alternate, one set of junctions A (Fig. 217) being exposed to the radiation, and the other set B being protected by a metal cap to maintain them at constant temperature.

A more sensitive arrangement is seen in Boys' radio-micrometer,¹ in which the couple and the galvanometer are combined in one instrument, the loop of wire which hangs between the poles of a powerful permanent horseshoe magnet terminating in a piece of antimony and one of bismuth soldered together at the tips. The radiation falling upon this junction warms it, and the thermo-electric force is established in the circuit, producing a current in the loop which, hanging in a magnetic field, experiences a couple. This arrangement has been modified to form a galvanometer by Duddell (see p. 80).

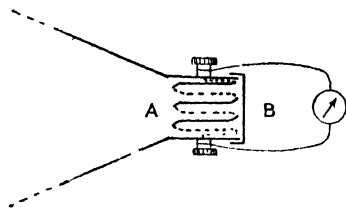

FIG. 217.

On referring to the thermo-electric diagram (Fig. 213) it will be seen that some of the thermo-electric lines, for example those of copper and silver, are nearly parallel; if they were actually parallel, the electromotive force round one of these couples would be proportional to the difference of the temperature of the junctions, since the figure $A_2C_2C_1A_1$ (Fig. 210) in this case becomes a parallelogram, and its area is proportional to the perpendicular distance between the sides A_1C_1 and A_2C_2 , that is, to $T_2 - T_1$. This fact is made use of in the case of pyrometers constructed for measurement of high temperatures. The couple is usually of pure platinum and an alloy of platinum and iridium, or platinum and rhodium, and is enclosed in a tube of suitable material for withstanding the temperature to which it will be exposed. In series with the couple, a millivoltmeter may be employed, which may be graduated in degrees Centigrade, and is of the type described on p. 86. In the case of the pyrometer made by Mr. R. W. Paul, the couple and voltmeter are each brought up to a standard resistance by means of a manganin resistance included in the instrument, and since this has a very small temperature coefficient of resistance, the error due to change of temperature of surroundings is negligible. Another advantage of this "swamping resistance" is that the various couples and voltmeters are interchangeable, the resistance in each case being the same for different instruments.

Thermo-milliammeter.—A sensitive form of ammeter, applicable

¹ C. V. Boys, *Phil. Trans.*, 180, A., p. 159. 1889.

to the measurement of small alternating or continuous currents has been devised by Prof. Fleming,¹ in which the heating produced by the current flowing in a fine constantan wire AB (Fig. 218) warms the junction of a tellurium-bismuth couple. The fine wires of tellurium and bismuth are soldered to the constantan wire, and the whole is situated in a high vacuum in a glass vessel. In this way considerable sensitiveness is obtained, and the galvanometer G in series with the thermo-electric couple, may be calibrated by passing a known continuous current through AB. Since the heating effect is proportional to the square

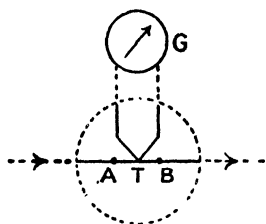

FIG. 218.

of the current the instrument may be used when the current is alternating (p. 347).

Radio-Balance.—The absorption of heat at a thermal junction, when the direction of the current is the same as that of the Peltier electromotive force, has been employed by Prof. Callendar² for the measurement of radiant heat. The radiation is absorbed by a blackened copper disc upon which it falls, and the rise in temperature in a given time might be measured by means of a thermo-electric couple of iron and constantan, which also acts as a suspension for the disc. To determine the rate of absorption of energy from the rate of rise of temperature would require a knowledge of the heat capacity of the system and the losses due to conduction and radiation, but, instead, the temperature is maintained constant by passing a current through a second thermal junction attached to the disc, and varying the strength until the cooling due to the Peltier effect compensates for the radiant heat absorbed. If the resistance of the arrangement were so small that the heating due to the Joule effect were negligible, we should have—

$$w = \pi i,$$

where w is the energy in ergs absorbed per second, π the Peltier coefficient, and i the current. But the resistance is never negligible, and the heating due to it being $i^2 r$ ergs per second,

$$\begin{aligned} w &= \pi i - i^2 r, \\ &= \pi i \left(1 - \frac{ir}{\pi} \right). \end{aligned}$$

Calling $\frac{\pi}{r}$ the neutral current i_0 , for which the Joule heating is

¹ J. A. Fleming, "The Principles of Electric Wave Telegraphy and Telephony."

² H. L. Callendar, *Proc. Phys. Soc. Lond.*, **23**, Part I., December, 1910.

just equal to the Peltier cooling ($i_0^2 r = \pi i_0$), so that the disc would be neither warmed nor cooled by such a current, we have—

$$w = \pi i \left(1 - \frac{i}{i_0} \right).$$

In the actual arrangement employed (Fig. 219) there are two similar discs, 1 and 2, each supported by four stout iron and four constantan wires, the two discs being thus the junctions of an iron-constantan couple. The discs also form the junction of the single-wire iron and constantan circuit in which the galvanometer G is included. Suppose that the radiation falls on the disc 1, the arrangement will be as shown in the diagram, and the current is adjusted by the resistance R until the two discs remain at the same temperature, as indicated by the current in G being zero. Knowing the current i , as indicated by the milliammeter A , and the Peltier coefficient π , w , the rate of absorption of radiant energy by the disc 1, is known. The neutral current i_0 is determined by a preliminary measurement in which no radiation falls upon either disc.

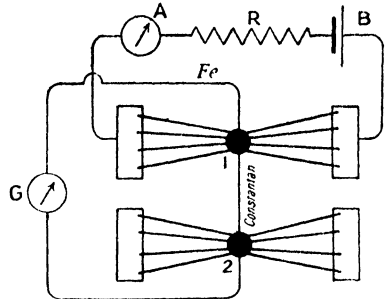

FIG. 219.

Should the whole apparatus become warmed by the radiation falling upon it, as would probably be the case when the sun's radiation is being measured, both discs are affected in the same way, and the error due to this cause is eliminated. Also the radiation may be allowed to fall on the disc 2 instead of 1, for the purpose of making a control measurement.

In a later design the discs are replaced by cups, for the purpose of rendering the absorption more complete; the electrical arrangements in this case are very similar to those in the disc apparatus.

The "cup" arrangement has also been used as a calorimeter and the Peltier coefficient, for a junction placed in either cup, directly measured. It has also been used for measuring the rate of emission of heat by radioactive substances (see p. 515).

Pyro-electricity.—Another electrical effect due to differences of temperature should be noticed. Certain crystals, especially tourmaline, exhibit electrical charges when heated or cooled. The name pyro-electricity is given to this phenomenon. If a crystal of tourmaline be raised in temperature, one end becomes positively and the other negatively charged while the temperature is rising, but during cooling the charges are reversed. This order of the charging takes

place whether the crystal be heated or cooled from the atmospheric or from any other temperature. If a crystal be broken up, each part of it exhibits the same properties, and if tourmaline be powdered and spread on a glass plate and warmed, or cooled, the particles gather themselves together in chains, owing to the polar charges, just as iron filings do when magnetised.

It has been thought that only hemi-mórfhic crystals exhibit pyro-electric properties, but according to Hankel¹ hemi-morphism is not indispensable to the production of pyro-electricity, and it is exhibited by other crystals, provided that their crystallographic axes are unequal; but, in the case of crystals having equal axes, only those which are hemi-morphic are pyro-electric. Boracite, quartz, and fluor are among the pyro-electric minerals.

Piezo-electricity.—It was discovered by the brothers Curie² that the crystals which exhibit pyro-electric properties are subjected to compression or tension, opposite charges of electricity appear at the ends of the crystal. Under compression the sign of the charge at either end is the same as would be produced by cooling the crystal, while tension produced charges of the same signs as those due to heating the crystal.

A suitable rectangular block is cut from the crystal, and a sheet of tinfoil laid over each end. The whole is then placed between ebonite blocks, to which the stress is applied. The quadrants of an electrometer being then connected to the tinfoils, the production of charge can be readily investigated.

It was found that the amount of charge produced at each end of a block of tourmaline is proportional to the total force applied to the block and not to the pressure, and that the amounts of positive and negative charge are equal.

The charges produced in this way were used at a later date for the measurement of ionisation current (p. 499) by a compensation method.

¹ Hankel, *Pogg. Ann.*, Bd. 49, 50, 53, and 56.

² J. and P. Curie, *Comptes Rendus*, 92, p. 186. 1881.

CHAPTER IX

ELECTROMAGNETICS

WE will now return to the consideration of Ampère's theorem given on p. 52, that an electric current is equivalent to a magnetic shell whose boundary coincides with the current. By a series of experiments, Ampère showed that the magnetic effect at distant points produced by a current, might in all cases be explained by the employment of a magnet or system of magnets, whose polar faces are bounded by the current. Thus a solenoidal current is equivalent to a bar magnet whose ends coincide with the faces of the solenoid, and a wire bent into a circle, when carrying current, is equivalent to a circular magnetic sheet or shell, whose polarity is N on one side and S on the other, the side whose polarity is N depending on the direction of the current. An inspection of Fig. 44 will make it clear which is the N side of the sheet. The following rule will be of assistance.

Imagine the conductor to be placed in the palm of the right hand and the fingers closed upon it, the thumb being outstretched; then if the thumb indicates the direction of the current, the fingers indicate the direction of the magnetic field.

It then follows that if we look upon the N side of a magnetic shell, the current flows in an anti-clockwise direction as seen by the observer.

If the coil have a number of turns, as in the case of a solenoid, the turns being approximately circles, each turn has its equivalent shell, and within the solenoid the N polar face of one shell coincides with the S polar face of the next, and the external effect of these inner shells is zero, but the N at one end of the solenoid, and the S at the other, produce a field similar to that of a uniformly magnetised circular bar magnet.

Strength of Magnetic Shell.—The magnetic moment per unit area of shell is called the strength of the shell. Thus if σ be the strength of the shell, and a its area, total magnetic moment of shell = $a\sigma$. Further, we will define the electromagnetic C.G.S. unit of current as one which produces the same magnetic field at external points as a magnetic shell of unit strength whose boundary coincides with the current.

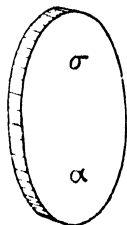

FIG. 220.

It is not necessary to define either the thickness of the shell or the amount of pole per unit area of face, as the magnetic moment of unit area of the shell is equal to the product of these two quantities; the shell is usually considered to be indefinitely thin.

When the current circuit is of very small dimensions, the equivalent shell becomes a small magnet and the magnetic potential and field at any point due to it may be calculated as on p. 14.

Thus $V = \frac{m \cos \theta}{r^2}$, and $H = -\frac{dV}{dr}$; but whatever the dimensions of the circuit, the method may be extended to give the same quantities.

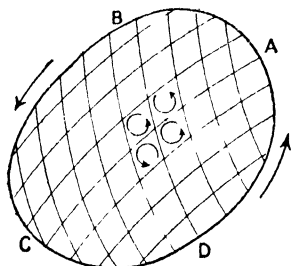

FIG. 221.

For the circuit ABCD (Fig. 221) may be divided up into a number of meshes by a network of conductors. If now in each mesh a current of strength equal to that in ABCD be considered to flow in the same direction, the side of each mesh not situated at the boundary will have equal and opposite currents flowing in it, and the total currents in the meshes are therefore zero, except at the boundary, where the resultant of the currents in the elements is the current in ABCD. Since each mesh may be replaced by the

equivalent element of a magnetic shell of strength equal to the current, the whole shell thus formed is equivalent to the current ABCD.

The magnetic potential at P (Fig. 222) due to a small element a of the shell is $\frac{a\sigma \cos \theta}{r^2}$, where $a\sigma$ is the magnetic moment of the element. Now if $d\omega$ be the solid angle subtended by a at P, $r^2 d\omega$ is the right section of the cone of angle $d\omega$, at distance r from the vertex P, and $\frac{r^2 d\omega}{a} = \cos \theta$.

$$\therefore d\omega = \frac{a \cos \theta}{r^2}.$$

Hence the potential at P due to this element may be written—

$$dV = \sigma d\omega.$$

And the potential at P due to the whole shell is, $\int dV = \int \sigma d\omega$, but σ being constant—

$$\text{Potential at P} = \sigma \int d\omega = \sigma \Omega,$$

where Ω is the solid angle subtended by the whole shell at P.

It follows that the potential at any point due to a shell depends only upon the strength of the shell and the solid angle subtended by it at the point, and this is independent of any variation in the shape of the shell, provided that its boundary is fixed. Thus for an infinite plane shell, the potential at neighbouring points is $2\pi \cdot \sigma$, and for a hemispherical shell the potential at the centre is also $2\pi \cdot \sigma$, since in each case the solid angle subtended at P (Fig. 223) by the shell is 2π .

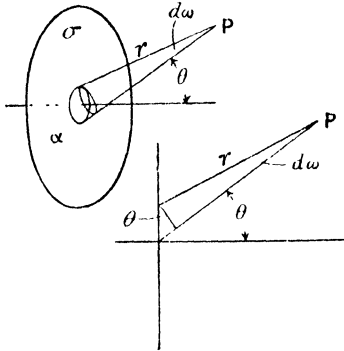

FIG. 222.

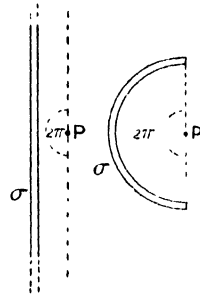

FIG. 223.

Circular Current.—If a current of strength i absolute units flow in a circle, we can replace it by a circular magnetic sheet of strength $\sigma = i$.

Let AB (Fig. 224) be a side view of the circle; then to find the magnetic potential at a point O on the axis, all that is necessary is to find the solid angle subtended by the circle at O. To do this draw a sphere with centre O, such that the circle lies upon the sphere. Then $\frac{\text{area of slice ACB}}{r^2} = \Omega$, where Ω is

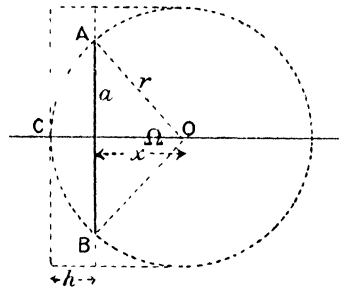

FIG. 224.

the solid angle required. Now it may be shown geometrically that the area of a slice of a sphere lying between two parallel planes is equal to the area of the circumscribing cylinder between the planes, and whose axis is perpendicular to these planes. The area of the slice ACB is therefore $2\pi rh$, where $h = r - x$, x being the distance of O from the plane of the circle.

$$\begin{aligned} \therefore \Omega &= \frac{2\pi rh}{r^2} = \frac{2\pi h}{r} = \frac{2\pi(r-x)}{r} \\ &= 2\pi\left(1 - \frac{x}{r}\right). \end{aligned}$$

But, magnetic potential $V = \sigma\Omega = i\Omega$;

$$\therefore V = 2\pi i \left(1 - \frac{x}{r}\right).$$

Noting that $r^2 = x^2 + a^2$, we have—

$$V = 2\pi i \left\{1 - \frac{x}{(x^2 + a^2)^{1/2}}\right\}.$$

By symmetry we see that the magnetic field due to the circular current is directed along the axis, and its value is therefore $-\frac{dV}{dx}$ (see p. 13).

$$\begin{aligned} \therefore H &= -\frac{dV}{dx} = -2\pi i \frac{d}{dx} \left\{1 - x(x^2 + a^2)^{-1/2}\right\} \\ &= 2\pi i \left\{-\frac{1}{2} \cdot x \cdot 2x(x^2 + a^2)^{-3/2} + (x^2 + a^2)^{-1/2}\right\} \\ &= \frac{2\pi a^2 i}{(x^2 + a^2)^{3/2}} \end{aligned}$$

For a point at the centre of the circle, $x = 0$, and then $H = \frac{2\pi i}{a}$, which is in accordance with the result derived from the law on p. 53.

Solenoidal Current.—When the current is flowing in a cylindrical sheet, its direction being everywhere perpendicular to the axis, it is said to be solenoidal, and the strength of magnetic field inside it may be found from the above relation. This condition is very nearly fulfilled by a current flowing in a wire closely wound upon a cylinder, when the thickness of the wire is small compared with the radius of the cylinder.

If i be the current per unit length of the solenoid, idx is that in a thin section of length dx (Fig. 225, i). The strength of

field at P due to this is $\frac{2\pi a^2 i dx}{(x^2 + a^2)^{3/2}}$,

where x is the distance of the plane of the circle from P. But, from the enlarged diagram (Fig. 225, ii) we see that $rd\theta = dx \cdot \sin \theta$,

$$\therefore dx = \frac{r \cdot d\theta}{\sin \theta}.$$

$$\text{And field due to section} = \frac{2\pi a^2 i \cdot r d\theta}{(x^2 + a^2)^{3/2} \sin \theta}.$$

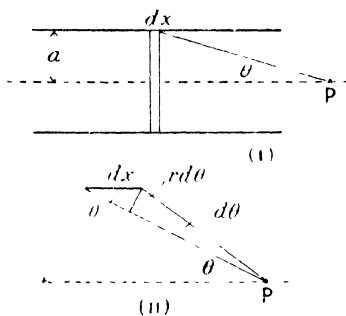

FIG. 225.

Remembering that $\frac{a}{r} = \sin \theta$, and $x^2 + a^2 = r^2$, we write the expression in the form—

$$\begin{aligned} \frac{2\pi i a^2 r \cdot d\theta}{r^3 \sin \theta} &= \frac{2\pi i a^2 \cdot d\theta}{r^2 \sin \theta} \\ &= 2\pi i \cdot \sin \theta \cdot d\theta. \end{aligned}$$

And for the whole solenoid, $H = 2\pi i \int_{\theta_1}^{\theta_2} \sin \theta \cdot d\theta$

$$= 2\pi i \left[\cos \theta \right]_{\theta_2}^{\theta_1}$$

where θ_1 and θ_2 are the values of θ at the ends of the solenoid.

If the solenoid consists of wire of n turns per centimetre length, the current in each turn being i ,

$$H = 2\pi n i \left[\cos \theta \right]_{\theta_2}^{\theta_1} = 2\pi n i \left[\cos \theta_1 - \cos \theta_2 \right].$$

When the length of the solenoid is infinite, $\theta_1 = 0$, and $\theta_2 = \pi$, and therefore—

$$H = 4\pi n i.$$

Work done in carrying a Magnetic Pole round a Current.—

Remembering that the difference in magnetic potential between two points is the work done in carrying a unit N pole from one point to the other, and that it is independent of the path along which the pole is carried, we may prove one of the most important laws connecting electric and magnetic quantities.

Consider two points P_1 and P_2 very close to, but on opposite sides of, the magnetic shell AB (Fig. 226) of which the N polar face is towards P_1 . The magnetic potential at P_1 due to the shell is $+\sigma \times$ (solid angle AP_1B), the solid angle AP_1B being shown by the dotted arc in the figure. Similarly the magnetic potential at P_2 is $-\sigma \times$ (solid angle AP_2B)

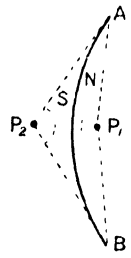

FIG. 226.

\therefore Difference of potential between P_1 and P_2

$$= \{ \sigma (\text{solid angle } AP_1B) \} - \{ -\sigma (\text{solid angle } AP_2B) \}$$

$$= \sigma (\text{solid angle } AP_1B + \text{solid angle } AP_2B)$$

As the points P_1 and P_2 approach each other, the sum of the solid angles AP_1B and AP_2B becomes more and more nearly equal to the solid angle subtended by the whole of space surrounding a point, that is to 4π , and since the magnetic shell may be considered to be indefinitely thin, the points P_1 and P_2 may approach each other until their distance apart is infinitesimal, and still they are on opposite sides of the shell. Hence the

difference of magnetic potential between two points P_1 and P_2 on opposite sides of, and very close to, a magnetic shell is $4\pi\sigma$, which is then the work done in carrying unit pole from P_1 to P_2 by any path, provided that the path does not intersect the shell. On passing through the shell from P_2 to P_1 , the direction of the force on the unit pole is reversed, and if the work were calculated it would be found to be equal and opposite to that for the external path from P_1 to P_2 . It is not necessary to perform this calculation, because the potential at a point such as P_1 , due to any distribution of magnetisation, can only have one value, so that the total work for a closed path is zero; otherwise useful work might be done by allowing a pole to circulate round a closed path, without any corresponding loss of energy in the system, and this is contrary to experience.

If, however, the shell be replaced by its equivalent current ($\sigma = i$) flowing round the boundary of the shell AB, the work for the external path from P_1 to P_2 is $4\pi\sigma$, or $4\pi i$, as in the case of the shell, but now the work required to complete the path in going from P_2 to P_1 may be made as small as we please by taking P_1 and P_2 sufficiently close together, there being in this case no magnetic material to traverse. A closed path such as we have described is necessarily linked once with the current, and thus *the work done in carrying a unit pole round a closed path linked once with a current i is $4\pi i$* , and the magnetic potential at any point in the neighbourhood of a current may be considered to have a number of potentials whose values differ by multiples of $4\pi i$. The potential due to a current is therefore multi-valued. There is, in this, no contradiction to the principle of the conservation of energy, for the current is not a statical phenomenon; it has to be maintained by the continuous expenditure of energy in the battery. When the magnetic pole is carried round the circuit, its field cuts the circuit during the process and produces current which, if in the opposite direction to the principal current, will cause a temporary lessening of the rate of expenditure of energy in the battery; if in the other direction, an increase in its rate. In either case we can trace the source, or the mode of disposal, of the energy corresponding to the work done in carrying the pole round the path linked with the current, to the change in the amount of chemical action occurring in the battery. After the completion of the path, the circuit is not in the same condition as at the start.

Line Integral of Magnetic Field.—The work done in carrying a

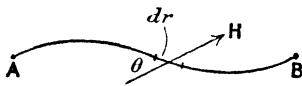

FIG 227.

unit pole along any path from one point to another is called the line integral of the field between the points. If the strength of field at any point of the path be H , and θ its inclination to the path, the component of the force on the pole, acting along the path, is $H \cos \theta$, and the work done in carrying it along an infinitesimal

length of the path dr is $H \cos \theta \, dr$. Thus the work done in carrying the unit pole from A to B is $\int_A^B H \cos \theta \, dr$. This is the line integral of the field along the path from A to B.

If the field has everywhere the direction of the path, the line integral becomes $\int_A^B H \, dr$.

We may now give our electromagnetic law the mathematical form—

$$\int_0 \text{H} \cos \theta \cdot dr = 4\pi i.$$

where the symbol \int_0 means that we take the line integral round a closed path. If the path is not linked with any current—

$$\int_0 \text{H} \cos \theta \cdot dr = 0.$$

The line integral of a field round a path enclosing unit area is sometimes called the Curl of the field, so that our relation would then be written—

$$\text{Curl H} = 4\pi \text{ (current density)}$$

Magnetic Field due to Straight Current.—The strength of magnetic field in several simple cases, may easily be calculated from the above law.

We have seen that the magnetic field due to an infinitely long straight wire carrying current is everywhere at right angles to the wire. If, therefore, we require the strength of magnetic field at a point P (Fig. 228), at a distance r from the wire, we may draw a circle through P having its centre on the wire. On carrying a unit pole round this circle, the field H is everywhere in the same direction as the path, and, by symmetry, it is constant.

Therefore, line integral of field = $2\pi r \cdot H$, and, from the above law, this is equal to $4\pi i$.

$$\therefore 2\pi r H = 4\pi i,$$

$$H = \frac{2i}{r}.$$

and,

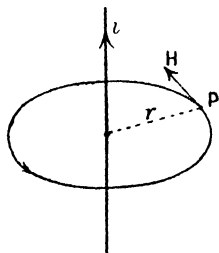

FIG. 228.

If the thickness of the wire be taken into account, so that its form is that of a solid cylinder, the field outside it is $\frac{2i}{r}$, at a distance r from the axis, but that inside it will be different. For let r_1 be the distance from the axis of a point inside the wire, and let i_1 be the

current density, that is the current flowing through unit area of cross-section of the wire. This is uniform over the whole section when the current is steady, and therefore the total current within the cylinder of radius r_1 is $\pi r_1^2 i_1$. The field at distance r_1 due to this current is

$$\frac{2(\pi r_1^2 i_1)}{r_1} = 2\pi r_1 i_1 = \frac{2r_1 i}{r},$$

where i is the whole current $\pi r^2 i_1$

This is the actual strength of field, since the current in the cylindrical shell lying outside the point, does not produce any field within it, the circular path inside not enclosing any of this current.

Thus the field due to a current in a cylinder is greatest at the surface of the cylinder, its value being there $\frac{2i}{r}$, and it

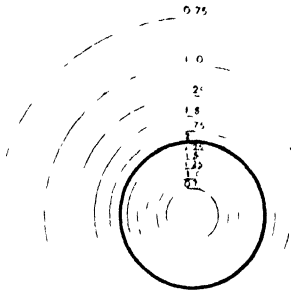

FIG. 229.

falls off as we pass either outwards or inwards, being zero at the axis. The distribution of the magnetic lines of force is shown in Fig. 229, the values of H being marked upon the circles when that at the surface of the conductor is taken to be 20 C.G.S. units.

Magnetic Field due to Solenoid — For a solenoid in the form of a ring, frequently called an endless solenoid, the line integral of the field round the axis of the solenoid (Fig. 230) is $2\pi rH$. If, then, there are n turns of wire per centimetre length of solenoid, there are in all $2\pi r n$ turns, and the circular path of radius r is linked $2\pi r n$ times with the current. If, then, i be the current in each turn, the effective current linked with the path is $2\pi r n i$, and it follows from the law given on p. 230, that

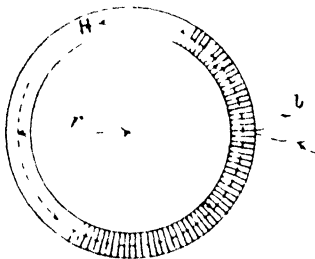

FIG. 230.

$$2\pi r H = 4\pi (2\pi r n i),$$

$$\therefore H = 4\pi n i.$$

It will be noticed that r will vary slightly according to whether the path is near the inner or the outer surface of the solenoid, and therefore the field is not quite uniform; but when the thickness of the solenoid is small compared with its radius, this departure from

uniformity of field is negligible, and if r be infinite, the solenoid is a straight one, and the field inside it is uniform, its value being $4\pi ni$. This is in agreement with the result obtained on p. 229.

Magnetic Permeability.—There is a close mathematical analogy between magnetic fields and statical electric fields, due to the similarity in the laws of force between magnetic poles and that between electric charges. In the magnetic, as in the electrical case, the force depends upon the medium in which the poles are situated. It is convenient to determine the unit of magnetic pole from the force between poles situated *in vacuo*, and this is practically the same as for air; but there are many media for which the force between the poles differs greatly from that between the same poles situated in air or *in vacuo*. We must, therefore, rewrite our force equation in the form —

$$\text{Force} = \frac{m_1 m_2}{\mu r^2},$$

where μ is a quantity depending upon the medium in which the poles are situated. It is called the *magnetic permeability* of the medium, for a reason to be given later.

On p. 3 we saw that the strength of field due to a pole of strength m at a distance r is $\frac{m}{r^2}$, but we now see that when the medium filling the space has permeability μ , field strength $H = \frac{m}{\mu r^2}$.

Again, the magnetic potential due to any distribution of poles is changed from V to $\frac{V}{\mu}$ when the medium is changed from air to one of permeability μ ; in fact, the magnetic equations are modified by the quantity μ in exactly the same way as we saw in Chapter V the equations for a statical electric field to be modified by the dielectric constant k ; but this difference should be noted, that whereas k is constant for any given medium, μ is by no means constant; its complex variations will be studied in Chapter X. Still μ has a definite value under all circumstances, defined by the equation $F = \frac{m_1 m_2}{\mu r^2}$, although this value may vary at different times and under different conditions.

Magnetic Induction.—The quantity $\mu H \cos \theta \cdot ds$ is defined as the *normal magnetic induction or magnetic flux* over the surface ds , where θ is the angle between H and the normal to ds ; and *Gauss's Law* in the magnetic case may be proved exactly as on p. 125 for the electrical case. Thus the total normal magnetic induction over a closed surface is equal to 4π times the amount of pole within it, and

$$\int \mu H \cos \theta \cdot ds = 4\pi \Sigma m.$$

It follows as on p. 128, that the strength of magnetic field due to

a plane polar sheet is $2\pi\sigma_0$, where σ_0 is the amount of pole per unit area of the sheet.

We give a special name to the quantity μH ; it is, the Magnetic Induction (B) and is analogous to N in the electrical case (p. 130), thus —

$$N = kE, \quad B = \mu H,$$

and the magnetic field may be mapped out by means of tubes of induction, whose characteristic property is that BS is constant for any tube. Thus in Fig. 231, if H_1 , H_2 and μ_1, μ_2 are the values of H and μ at the sections of the tube of induction having areas S_1 and S_2 , the normal induction over the sides of the tube is zero, their direction being everywhere that of the field, we have from Gauss's law when there is no pole within the tube —

$$\mu_1 H_1 S_1 = \mu_2 H_2 S_2$$

or,

$$B_1 S_1 = B_2 S_2$$

FIG. 231.

Similarly the amount of energy per unit volume of the medium is —

$$\frac{\mu H^2}{8\pi} = \frac{B^2}{8\pi\mu} = \frac{HB}{8\pi} \quad (\text{see p. 131}).$$

Boundary Conditions.—Following the analogy we see, as on p. 140, that the boundary conditions that must be satisfied at the surface of separation of two media of different magnetic permeabilities are

(i) The tangential components of the field are the same in both media ;

i.e.

$$H_1 = H_2$$

and (ii) The normal components of the magnetic induction are the same in the two media ;

i.e.

$$B_1 = B_2, \text{ or, } \mu_1 H_1 = \mu_2 H_2$$

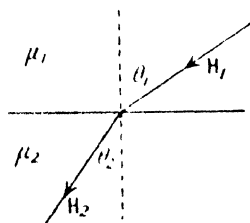

FIG. 232.

Thus for a line of induction which crosses the boundary we have (Fig. 232)---

$$\text{from (i)} \quad H_1 \sin \theta_1 = H_2 \sin \theta_2,$$

$$\text{and from (ii)} \quad \mu_1 H_1 \cos \theta_1 = \mu_2 H_2 \cos \theta_2.$$

Dividing one equation by the other, we have--

$$\frac{\tan \theta_1}{\tan \theta_2} = \frac{\mu_1}{\mu_2}.$$

The problem of a sphere of permeability μ_2 situated in a medium of permeability μ_1 , the original field H being uniform, is exactly

analogous to that for the dielectric sphere in an electrical field E (pp. 142 to 144), and the argument may be repeated, replacing E by H , k_1 and k_2 by μ_1 and μ_2 . The resultant field H_2 inside the sphere is thus

$$H_2 = \frac{3\mu_1}{\mu_2 + 2\mu_1} H \quad (\text{p. 143}).$$

Fig. 153 may illustrate the case in which $\mu_2 > \mu_1$, as in the case of the magnetic metals, iron, nickel, and cobalt, situated in air; these substances are said to be ferromagnetic. In Fig. 154, $\mu_1 > \mu_2$, a condition which is fulfilled for some substances in air, in which case the substance is said to be diamagnetic. The most diamagnetic substance is bismuth, for which $\mu = 0.99997$.

Magnetic Shielding. The tendency of the magnetic tubes of induction to concentrate upon places of high permeability explains the use of hollow iron spheres and cylinders to reduce the magnetic field in the spaces within them. It is sometimes desirable to protect a suspended needle galvanometer from magnetic disturbances, and although this can never be completely effected, the disturbing field may be very much reduced by surrounding the instrument by massive iron shields. The calculation of the change in field produced is beyond the scope of our present work, but the results for a sphere and a cylinder are of use. They have been given by du Bois.¹

The field inside a hollow sphere is —

$$\frac{H}{1 + \frac{2}{9}(\mu - 2)\left(1 - \frac{r^4}{R^4}\right)},$$

where H is the external field, μ the permeability, and r and R the internal and external radii. For a cylinder with axis at right angles to the field it is—

$$\frac{H}{1 + \frac{1}{4}(\mu - 2)\left(1 - \frac{r^2}{R^2}\right)},$$

Force on Magnetic Body in Uniform Field.—We saw on p. 139 that a body of dielectric constant greater than that of the surrounding medium situated in an electric field that is not uniform, tends to move towards the stronger parts of the field, and the same consideration would lead us to a like conclusion in the case of a paramagnetic or ferromagnetic body. Since the force on small bodies has been used for measuring their magnetic properties, we will calculate the force on such bodies.

Let the body consist of two poles of strength m , the magnetic potential at the respective poles being V_n and V_r .

¹ H. du Bois, *Electrician*, 40, p. 317. 1898.

Then potential energy of body = $m(V_n - V_s)$,

being the work done in bringing the body from infinity to the point, and if the distance between the poles be ds --

$$\begin{aligned} \text{potential energy} &= mds \cdot \frac{V_n - V_s}{ds} \\ &= M \frac{dV}{ds}, \end{aligned}$$

when ds becomes sufficiently small, and M is the magnetic moment of the body. Further, $\frac{dV}{ds} = -H$, and $M = vI$, where v is the volume of the body and I the intensity of magnetisation (see p. 267).

$$\therefore \text{potential energy} = -vIH.$$

Now the work done during a small displacement of the body is the difference in the potential energy before and after the displacement, and it is also equal to the product of the force F in the direction of the displacement and ds the amount of displacement.

$$\begin{aligned} \therefore Fds &= d(-vIH), \\ \text{or, } F &= -vI \frac{dH}{ds}. \end{aligned}$$

In the case of a sphere of susceptibility k , placed in a field of strength H , we shall see on p. 269 that--

$$\begin{aligned} I &= \frac{kH}{1 + \frac{4}{3}\pi k}, \\ \therefore F &= -\frac{1}{2} \frac{vk}{1 + \frac{4}{3}\pi k} \frac{dH^2}{ds}, \\ &= -\frac{v}{2} \cdot \frac{k}{1 + \frac{4}{3}\pi k} \frac{dH^2}{ds}. \end{aligned}$$

Hence when the field is uniform H^2 is constant, and there is no force on the body, and further, the direction of the greatest value of F is that in which H^2 varies most rapidly: again when k is negative, or is less than that of the surrounding medium, the direction of F is reversed. Since paramagnetic bodies tend to move from the weaker to the stronger parts of the field, diamagnetic bodies tend to move towards the weaker parts of the field.

Equivalence of Current and Magnetic Shell in any Medium.-- The work done in carrying a unit magnetic pole round a closed path linked with a current is independent of the presence of any distribution of magnets there may be, since the work done in traversing the closed path, and due to any magnets in the neighbourhood, we have seen to be zero (p. 230). It follows that if there are magnets or magnetic material in the neighbourhood of the current, they will not change the

amount of work done in carrying a unit magnetic pole round the closed path, which is therefore always $4\pi i$.

If then, the whole of space is filled with a medium of permeability μ , differing from unity, the magnetic field is everywhere the same as when the permeability was unity, and the work done by our unit pole in its circuital path is still $4\pi i$. If the space be partly filled with magnetic material the work is still $4\pi i$, but owing to the presence of free poles at the boundary of the magnetic material, the field will be increased at some points and diminished at others, a fact which will be seen in dealing with the demagnetising effect in the interior of a mass of iron in a magnetic field (p. 269).

We must modify our conception of the equivalent magnetic shell for a given current circuit to bring it into accordance with these ideas. For we see that on filling space with a material of permeability μ , the field everywhere due to the current is unchanged, but that due to the magnetic shell is reduced to $\frac{1}{\mu}$ of its previous value (p. 233). Hence if the shell is still to be equivalent to the current we must increase its strength μ times, and we may then say that *in a medium whose permeability is everywhere μ , the current is equivalent to a magnetic shell of strength σ , where $\sigma = \mu i$.*

Force on Current in Magnetic Field.—The equivalence of a current and a magnetic shell leads us to the conclusion that a conductor in which an electric current is flowing will experience a force when situated in a magnetic field; in fact, it was by a series of experiments in which the forces on circuits carrying current were produced by magnets, that Ampère established the equivalence of a current and a magnetic shell. The direction and magnitude of the force may be found as follows.

Consider the circuit ABC, in which current i is flowing, to be displaced always parallel to itself through distance dx , so that its new position is A'B'C' (Fig. 233). Owing to the presence of a N pole of strength m , situated at N, work is done when the displacement occurs, and the potential energy of the system consisting of the pole and the current is changed, on moving the circuit from the first to the second position, by an amount equal to the work done in displacing the circuit.

Let Fds be the force on element ds of the conductor, acting in the direction of the displacement, F being the force per unit length at this

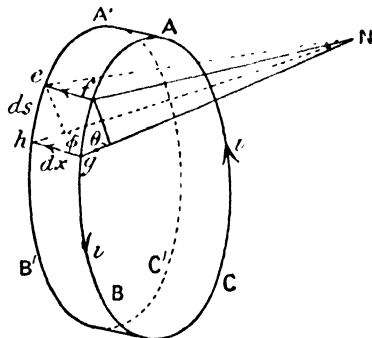

FIG. 233.

part of the circuit. Then $F ds \cdot dx$ is the work done on the element ds during the displacement. And for the whole circuit

$$\text{work done during displacement} = \Sigma F ds \cdot dx.$$

The area swept out by the element ds is that of the figure $efgh = ds \cdot dx \cdot \sin \phi$; and the solid angle subtended by this at the point N is—

$$\frac{(\text{area } efgh) \sin \theta}{r^2} = \frac{ds \cdot dx \cdot \sin \phi \cdot \sin \theta}{r^2},$$

where θ is the angle between the line joining N to $efgh$, and the plane of $efgh$; and therefore the solid angle subtended at N by the whole curved surface $ABCC'B'A'$ is—

$$\Sigma \frac{ds \cdot dx \cdot \sin \phi \sin \theta}{r^2}.$$

Now if the solid angles subtended by the circuits ABC and A'B'C' at N be respectively Ω and Ω' ,

$$\begin{aligned} \Omega - \Omega' &= \text{solid angle subtended by } ABCC'B'A' \\ &= \Sigma \frac{ds \cdot dx \cdot \sin \phi \sin \theta}{r^2}. \end{aligned}$$

But change of potential at N produced by the displacement of the circuit (p. 226)

$$= i\Omega - i\Omega' = i \Sigma \frac{ds \cdot dx \cdot \sin \phi \sin \theta}{r^2}.$$

The change in potential measures the difference in the amounts of work required to bring unit pole from infinity to N, when the circuit is at ABC and A'B'C' respectively, and is therefore the change in potential energy of the system for the given displacement when the pole has unit strength. But since the pole has strength m , this change in potential energy is—

$$\begin{aligned} &= mi \Sigma \frac{ds \cdot dx \cdot \sin \phi \sin \theta}{r^2}, \\ \therefore \Sigma F ds \cdot dx &= mi \Sigma \frac{ds \cdot dx \cdot \sin \phi \sin \theta}{r^2}. \end{aligned}$$

And for this equation to be satisfied—

$$F = \frac{mi \sin \phi \sin \theta}{r^2}.$$

The greatest value of this for a given value of θ occurs when $\phi = 90^\circ$, that is, the force is greatest in a direction at right angles to that of the current, in which case $F = \frac{mi \sin \theta}{r^2}$, and for an element ds —

$$\text{Force} = \frac{mi \cdot ds \sin \theta}{r^2},$$

and further, for a given displacement in any direction the work done, and therefore the force on the element, is greatest when the solid angle subtended by the circuit is changed most for that displacement, and this is greatest when it is at right angles to r , which is the direction of the magnetic field due to N . The resultant force on the element is therefore always at right angles to the magnetic field, and we have seen that it is at right angles to the element ds , and hence it is at right angles to the plane containing the element of the current and the direction of the magnetic field.

We see from Fig. 233 that in this case θ is the angle between the current and the field, and therefore the force per unit length of conductor is $\frac{mi \sin \theta}{r^2}$. But $\frac{m}{\mu r^2}$ is the strength of magnetic field H due to the pole, and $\mu \frac{m}{r^2}$ ($= \frac{m}{r^2}$) is the induction B due to it.

\therefore Force per unit length of conductor $= Bi \sin \theta$, and is at right angles to B and to i . The force is $H i \sin \theta$ when $\mu = 1$.

It will be seen in Fig. 234 that the directions of the quantities i , H , and F are related to each other as in Fig. 233, which may be remembered

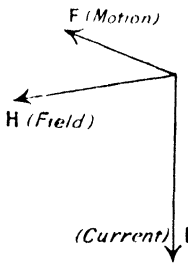

FIG. 234.

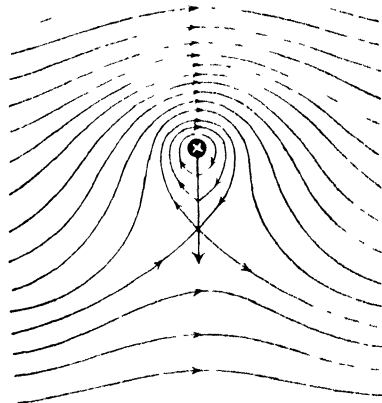

FIG. 235.

by Fleming's Left Hand Rule. If the thumb, fore, and middle fingers of the left hand are extended so that they are mutually at right angles, and the middle finger point in the direction of the current (I), the Fore finger in the direction of the magnetic Field, then the thumb points in the direction of Motion when the circuit moves owing to the action of the field.

The same conclusion regarding the direction of the force experienced by a current situated in a magnetic field may be reached by considering the magnetic lines of force of the resultant field. Those of the original magnetic field are parallel straight lines and those due to the linear current are circles. The magnetic lines for the current and field combined are shown in Fig. 235, when the current flows downwards through the plane of the paper. The lateral pressures between the tubes of force above the wire where they are crowded together is greater than below it, and the result will be that the wire experiences a force which is directed downwards in the diagram, it will be seen that this is the direction previously found for it.

Suspended Coil.— We can thus explain the use of a suspended coil for galvanometric purposes; for a rectangular coil carrying current

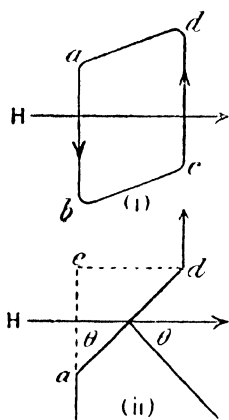

FIG. 236.

experiences a couple when suspended in a magnetic field. The rectangular coil $abcd$ (Fig. 236 i) may be considered to be the suspended coil of a galvanometer. Then the force per unit length of ab and dc is Hi , and the total force $Hi(ab)$, the direction of the forces being shown in the plan (Fig. 236 ii). These give rise to a couple $Hi(ab)(cd)$ tending to twist the coil into the position in which its normal has the same direction as the field.

$$\begin{aligned} \text{Couple} &= Hi(ab)(cd) = Hi(ab)(ad) \sin \theta \\ &= Hi A \sin \theta, \end{aligned}$$

where $A = ab \times ad$, the area of the coil. The sides ad and bc do not contribute anything to the couple, since the forces on them are vertical, that on ad being vertically upwards and that on bc vertically downwards.

The couple $HiA \sin \theta$ might have been derived directly by replacing the circuit by its equivalent magnet shell, whose magnetic moment is iA , and is in the direction of the normal to the coil. The couple on this is $HiA \sin \theta$.

If the uniform field H be due to a permanent magnet, and the coil be suspended by a metallic wire which exerts a controlling couple $c\theta'$, where θ' is the angle between the plane of the deflected coil and the field, equilibrium is attained when—

$$\begin{aligned} c\theta' &= HiA \cos \theta', \\ \text{or,} \quad i &= \frac{c}{HA} \cdot \frac{\theta'}{\cos \theta'} \end{aligned}$$

The instrument is very much simplified by employing a radial field, in which case the vertical sides of the coil seen at a and d in Fig. 237, experience forces Hi always at right angles to the plane of the coil,

where l is the length of the vertical side. The deflecting couple is $Hil(ad) = HiA$.

The coil therefore comes to rest when—

$$c\theta = HiA,$$

or,

$$i = \frac{c}{HA} \theta,$$

and the current is directly proportional to the deflection.

The radial field has the advantage that the couple due to the current does not depend on the position of the coil, whereas in uniform field it varies as the sine of the angle between the field and the normal to the coil.

Effect of Current on Current.—From Ampère's law of the equivalence of a current circuit to a magnetic shell, we should expect that forces would exist between two circuits carrying current. Such effects may easily be produced, and their magnitudes may be calculated from the forces between the equivalent shells. Thus, for two circular currents mutually at right angles (Fig. 238) where AB is a large circle

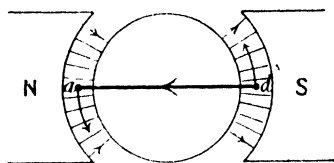

FIG. 237.

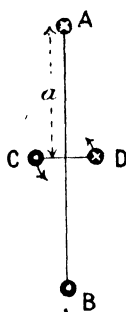

FIG. 238.

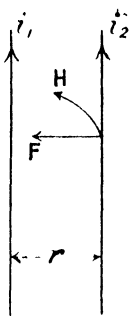

FIG. 239.

and CD a small one, we have seen (p. 228) that the field at the centre of AB is $\frac{2\pi i_1}{a}$, where a is the radius and i_1 the current; the magnetic moment of the small coil is ai_2 where a is its area and i_2 the current in it. Hence CD will experience a couple $\frac{2\pi i_1 i_2 a}{a}$ tending to twist its plane into that of AB when the two are at right angles, or $\frac{2\pi a i_1 i_2}{a} \sin \theta$ when the planes of the two coils are inclined to each other at an angle θ .

Again, the long straight current i_1 (Fig. 239) produces a magnetic field $\frac{2i_1}{r}$ at a distance r from it, and a second straight current i_2

parallel to the first will experience a force $H i_2$ or $\frac{2i_1 i_2}{r}$ per unit

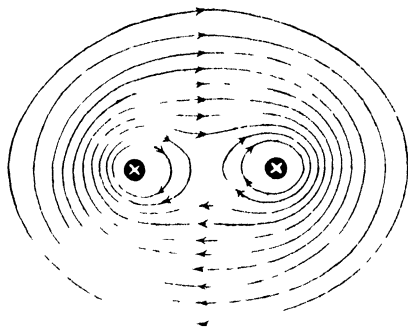

FIG. 240.

length, and it will be seen that when the currents are in the same direction the force urges i_2 towards i_1 ; when the currents are in opposite directions the force drives i_2 away from i_1 . In each case an equal and opposite force acts on each unit length of i_1 , and we see that currents in the same direction attract each other; those in opposite directions repel each other.

On drawing the magnetic lines of force due to the two parallel wires we come to the same conclusions. When the currents are in the same direction (Fig. 240) the two wires are surrounded by lines or tubes of force, which, by their contraction, would urge the wires

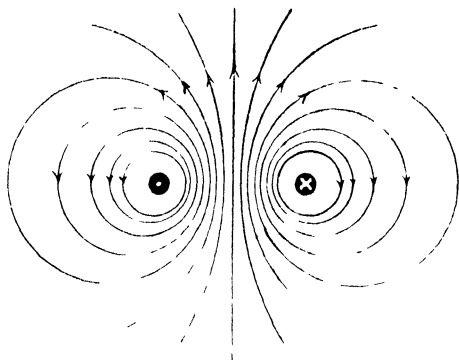

FIG. 241.

together. When the currents are in opposite directions (Fig. 241), there are no tubes of force surrounding both wires, and since they are more crowded in the space between the wires than in that outside, the lateral pressures of the tubes will urge the wires apart.

Coaxial Coils.—(1) For two circular coaxial coils of very nearly the same radius, situated a small distance apart, the force on each unit of length of either coil is $\frac{2i_1 i_2}{ab}$ (Fig. 242) in the direction ab . The com-

ponent of this, normal to the axis, taken all round the coils, will, by symmetry, vanish, but the component parallel to the axis is —

$$\frac{2i_1 i_2}{ab} \frac{ac}{ab} = \frac{2i_1 i_2}{(ab)^2} x \text{ for unit length,}$$

and for the whole circle, since total length is $2\pi r_1$, r_1 being very nearly equal to r_2 —

$$\begin{aligned} \text{Force} &= \frac{2i_1 i_2 \cdot x \cdot 2\pi r_1}{(r_2 - r_1)^2 + x^2} \\ &= \frac{4\pi i_1 i_2 \cdot x}{(r_2 - r_1)^2 + x^2} \end{aligned}$$

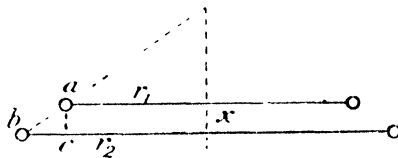

FIG. 242.

This is zero when $x = 0$, i.e. when the coils are in the same plane, and its maximum occurs when $\frac{x}{\Lambda^2 + x^2}$ is a maximum, putting Λ^2 in place of $(r_2 - r_1)^2$.

$$\text{Now, } \frac{d}{dx} \left(\frac{x}{\Lambda^2 + x^2} \right) = \frac{(\Lambda^2 + x^2) - 2x^2}{(\Lambda^2 + x^2)^2} = \frac{\Lambda^2 - x^2}{(\Lambda^2 + x^2)^2}$$

Putting this equal to zero we have $\Lambda^2 = x^2$. On obtaining $\frac{d^2}{dx^2} \left(\frac{x}{\Lambda^2 + x^2} \right)$ and substituting Λ^2 for x^2 the result is negative, and therefore $\Lambda^2 = x^2$ or $(r_2 - r_1)^2 = x^2$ corresponds to a maximum. The force between the coils is therefore a maximum when $x = r_2 - r_1$, and its value is then—

$$\frac{2\pi i_1 i_2 r_1}{r_2 - r_1} \quad \begin{array}{c} r_1 \\ \vdots \\ x \end{array}$$

When the coil r_1 is so small that the variation of the field over its surface, due to the coil r_2 , is negligible, let H be the field due to r_2 (Fig. 243). Then if the magnetic shell due to r_1 have thickness dx , and pole strength m per unit of area —

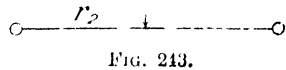

FIG. 243.

$$\text{force on under face} = H \cdot m \cdot \pi r_1^2,$$

$$\text{field at upper face} = H + \frac{dH}{dx} \cdot dx,$$

$$\text{and, force on upper face} = \left(H + \frac{dH}{dx} \cdot dx \right) m \cdot \pi r_1^2.$$

The resultant force on the small coil is the difference of the forces on the upper and lower faces, that is—

$$\frac{dH}{dx} \cdot dx \cdot m \cdot \pi r_1^2.$$

But $m \cdot dx$ is the magnetic moment of unit area of the shell; that is, the strength σ of the shell.

$$\therefore \text{force} = \pi r_1^2 \cdot \sigma \cdot \frac{dH}{dx}.$$

But $\sigma = i_1$, the current in r_1 .

$$\therefore \text{force} = \pi r_1^2 i_1 \cdot \frac{dH}{dx}.$$

Now on p. 228 we showed that—

$$\begin{aligned} H &= \frac{2\pi r_2^2 i_2}{(r_2^2 + x^2)^{\frac{3}{2}}}, \\ \therefore \frac{dH}{dx} &= -\frac{6\pi r_2^2 i_2 x}{(r_2^2 + x^2)^{\frac{5}{2}}}, \\ \therefore \text{force} &= \frac{6\pi^2 r_1^2 r_2^2 i_1 i_2 \cdot x}{(r_2^2 + x^2)^{\frac{5}{2}}}. \end{aligned}$$

This is evidently zero when $x = 0$, and by differentiating it again we may show that it is a maximum when $x = \frac{r_2}{2}$.

Kelvin's Ampere Balance.—Although the forces between current circuits cannot in general be calculated by simple means, it follows from the equivalence of the circuits with magnetic shells, that the forces between them are always proportional to the product of the current strengths.

In the case of Kelvin's ampere balance, the forces between parallel

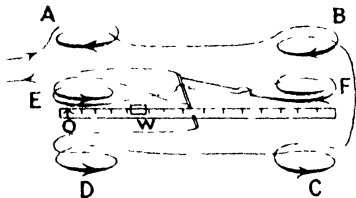

FIG. 244.

circular coils are balanced against a gravitational force. The value of the current cannot be determined in absolute measure from the force and the dimensions of the coils, so that it is necessary to calibrate the instrument by means of a silver voltameter. The four coils, A, B, C, D (Fig. 244), are fixed, and the two, E and F, are attached to the moveable arm which also carries a horizontal scale on which the weight W slides. The coils are all connected in series in such a way that when the current flows, the forces between A and E, D and E, urge E downwards; similarly F is urged upwards. The moveable arm is suspended

by the conducting wires which bring the current to E and F, and the centre of gravity of the arm can be adjusted by means of a metal flag until, when there is no current, the arm is horizontal when the sliding weight W is on the zero mark. The couple due to the current can then be balanced by sliding W to the right along the arm, the couple being proportional to the displacement of the weight. Since the force between any pair of coils is proportional to the current in each, the downward force on E and the upward force on F are each proportional

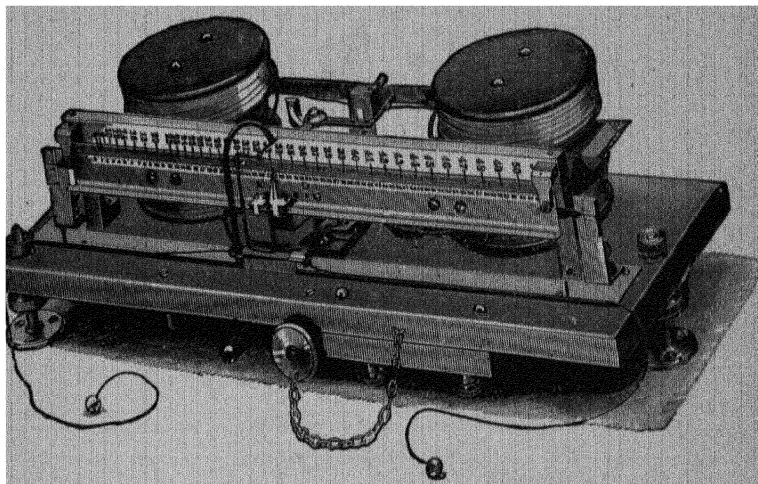

FIG. 245.

to the square of the current in the instrument, and the couple is therefore proportional to i^2 .

Thus if d is the displacement of W required to restore equilibrium on passing the current—

$$i^2 \propto d$$

$$\text{or, } i = k\sqrt{d}.$$

The constant k is determined when the instrument is calibrated, and a fixed scale is also attached which is marked directly in amperes.

There are several weights supplied with the instrument to alter the range, and for each weight a corresponding counterpoise also supplied must be placed in the tray at the end of the beam.

The general appearance of the instrument is shown in Fig. 245.

Kelvin Watt-Balance.—The watt-balance is similar in design to the ampere balance, but the moveable coils E and F (Fig. 246) have high resistance and are not connected in series with the fixed coils. If the power absorbed in say a lamp L is required, the current in the lamp is caused to flow through the fixed coils A, B, C, and D in series. The

moveable coils E and F are connected through a high resistance R_1 (to make the resistance up to in some cases 1000 ohms) to the points MN between which the power is being absorbed. Then if the current in the lamp is I amperes, this is also the current in the fixed coils, and

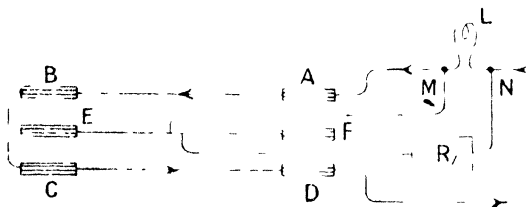

FIG. 246.

if the difference of potential between M and N is E volts, the current in the moveable coils is $\frac{E}{R}$, R being their resistance together with R_1 . The force between each pair of coils B-E, E-C, etc., being proportional to the current in each, is proportional to $\frac{IE}{R}$, and the couple acting on the beam, due to these forces being balanced as before by the displacement d of the weight, we have—

$$\frac{IE}{R} \propto d,$$

or, since R is constant,

$$IE = kd.$$

But IE is the power in watts absorbed in the lamp, and this is consequently proportional to the displacement of the moveable weight required to maintain equilibrium. The constant k is determined by finding the displacement d for a known power, as measured by a standard ammeter and voltmeter, and the scale is usually graduated directly in watts. The adjustments are carried out as in the case of the current balance, and several weights are supplied to enable the range of the instrument to be varied.

Siemens' Electro-Dynamometer.—Two coils, ABCD and $abcd$, are situated at right angles to each other, and when the instrument is used as an ammeter the coils are connected in series. With the connections as shown in Fig. 247, there is an attraction between AB and ab and also between CD and cd , the currents being in the same direction; but between AB and cd , and likewise between ab and CD, there are repulsions, and it will be noticed that all these forces tend to rotate the coil ABCD in the direction marked by the arrows, and further, that each of these forces is proportional to i^2 . ABCD is suspended by a

fibre and the light spiral spring *S*, which is attached to a pointer at the torsion head, and exerts a controlling couple, proportional to the twist in the spring. A pointer *P* is attached to the moveable coil and serves as an indicator. This is in its equilibrium position for zero current. On passing the current, the coil is deflected, but is brought back to its zero position by rotating the torsion head, the amount of twist necessary to be put into the spring to effect this being measured by means of the circular scale.

$$\begin{aligned} \text{Then,} \quad \text{couple} &\propto \text{twist} (= \theta) \\ &\propto i^2 \\ \therefore i^2 &\propto \theta, \text{ or, } i = k\sqrt{\theta}. \end{aligned}$$

The constant *k* may be found by observing θ for a known current, and the instrument may afterwards be used as an ammeter.

This instrument is sometimes designed for use as a wattmeter; the fixed coil having a great many turns of fine wire to ensure a high resistance. The low resistance coil is then placed in series with the circuit, the power absorbed in which it is required to measure, and the high resistance coil is placed in parallel across it.

With this arrangement, current in series coil is *I*, and current in shunt coil $\frac{E}{R}$, as in the case of the Kelvin wattmeter (p. 246).

$$\begin{aligned} \therefore \text{couple} &\propto \frac{EI}{R} \propto \theta, \\ \therefore EI &= k\theta. \end{aligned}$$

Thus the power absorbed in the circuit is directly proportional to the twist in the spring necessary to maintain the moveable coil in equilibrium at its zero position.

Electromagnetic Induction.—While attempting to find out whether a steady current produces another in neighbouring circuits, in a manner analogous to that in which electric charges are produced by the influence of other charges (p. 113), Faraday found that so long as the current is steady the result is negative, but on starting the current, a transient current in the opposite direction flows in the neighbouring circuit. The arrows in Fig. 248 indicate the directions of the transient currents in *B* when that in *A* is started and stopped. Exactly similar effects might be produced in *B* by advancing towards it from the side *A*, a bar magnet with its *S* pole facing *B*. The transient current in *B* is in the direction of that produced on starting

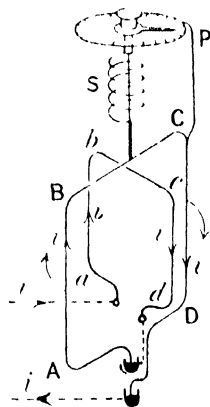

FIG. 247.

the current in A. Similarly on withdrawing the magnet the effect is the same as that of stopping the current in A.

Faraday explained these results by stating that when the total magnetic induction linked with a circuit changes, an electromotive force acts round the circuit, the direction of the electromotive force depending on the sign of the change of magnetic induction.

The actual value of the electromotive force due to a change in the magnetic induction linked with any circuit, may be deduced from our knowledge of the force acting on a circuit carrying current in a magnetic field, by making use of the principle of the conservation of

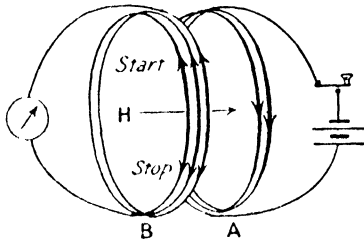

FIG. 248.

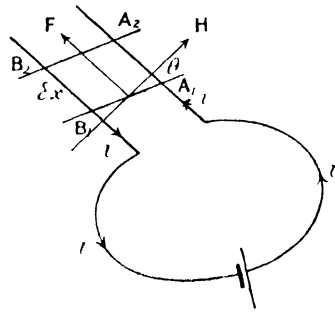

FIG. 249.

energy. Consider a piece A_1B_1 of a circuit in which current i is flowing (Fig. 249), and let H be the magnetic field, making an angle θ with A_1B_1 . Then the force per unit length of A_1B_1 is $H i \sin \theta$ and is in the direction F at right angles to H and A_1B_1 . Let A_1B_1 slide upon parallel conducting rails in the direction of this force. If length of A_1B_1 is l , work done for displacement δx , is—

$$F \delta x = H i l \sin \theta \cdot \delta x.$$

Now, if e be the electromotive force of the battery maintaining the current i , work done in time δt is $e i \delta t$, and this is partly used in overcoming the resistance r of the circuit, the remainder being employed in moving the conductor A_1B_1 . Now, work done in overcoming resistance is $i^2 r \delta t$, and if there is no other action than these two in the circuit, we have by the principle of the conservation of energy—

$$e i \delta t = i^2 r \delta t + H i l \sin \theta \cdot \delta x,$$

$$e = \frac{H l \sin \theta \cdot \delta x}{\delta t}.$$

or, $i = \frac{e}{r}$

Thus the electromotive force e of the circuit is opposed by an electromotive force $\frac{H l \sin \theta \cdot \delta x}{\delta t}$.

On referring again to Fig. 249, we see that $l\delta x$ is the area described by the conductor in moving a distance δx , and $H \sin \theta$ is the component of H perpendicular to this. Hence the product $(H \sin \theta)(l\delta x)$ is the total normal magnetic induction over the area $A_1B_1B_2A_2$ when the medium is air; when the space has permeability μ , we must multiply by this amount, and in the above reasoning H must be replaced by B .

In any case, calling N the total normal induction over the whole circuit, $B l \sin \theta \cdot \delta x$ is the change in this amount (δN) on account of the motion of A_1B_1 , and we therefore see that this motion produces an electromotive force $\frac{\delta N}{\delta t}$ in the circuit. In the limit when δt is infinitesimal—

$$\text{E.M.F. due to change of induction} = - \frac{dN}{dt}.$$

The negative sign is taken because the electromotive force always opposes that producing the current, when the motion of the circuit is in the direction due to the electromagnetic actions themselves. If by some external agency the conductor were forced from A_2B_2 to A_1B_1 the direction of the induced electromotive force would be the same as e , but N is now diminishing, so that $\frac{dN}{dt}$ is again negative.

Rule I.—The direction of the induced electromotive force is related to that of the motion and the magnetic field, in a manner illustrated by the three vectors in Fig. 250, the positions of which may be remembered by means of Prof. Fleming's *Right Hand Rule*. Extend the thumb, fore-finger, and middle finger of the *Right* hand until they are mutually at right angles. Then if the *Fore* finger points along the magnetic *F*ield, the *m*iddle finger along the current, *I*, the *th*umb will then point in the direction of *M*otion.

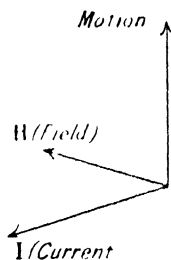

FIG. 250.

Rule II.—Another simple and useful rule for remembering the direction of the current in the whole circuit may be obtained by an inspection of Fig. 248. If the observer look along the magnetic lines of force towards the circuit, the induced current is anti-clockwise when the induction is increasing, and clockwise when it is diminishing.

If the circuit in Fig. 249 were considered to be flexible so that each element were moveable, each part would travel outwards, the limit of travel being reached when the conductor became circular, in which case it would embrace the maximum amount of induction, and hence the rule given by Maxwell, that a circuit always tends to move in that direction which tends to make the amount of induction through it a maximum. This rule is sometimes of great convenience in determining the direction of a force acting on a circuit due to a magnetic field.

It should be noted that if the direction of H in Fig. 249 be reversed, the direction of motion is reversed. The circuit, if flexible, will then shrink and will eventually turn over and expand in the opposite direction, the motion all the time being in a direction towards

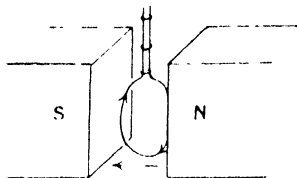

FIG. 251.

the condition for the embracing of maximum magnetic induction by the circuit. This may easily be shown by taking a loop of thin, flexible, rubber-covered wire and tying a piece of thread round at a distance of about 10 cms. from the end of the loop. On hanging it between the poles of an electromagnet (Fig. 251) the loop will spread out to an approximately circular form on passing a current of a few amperes round it. If the current be suddenly reversed, the loop collapses, and expands in the opposite direction, always reaching equilibrium when the current is clockwise, as seen from the N pole of the magnet.

Lenz's Law.—Another generalisation on the laws of electromagnetic induction is due to Lenz,¹ which states that when a conductor moves with respect to a magnetic field, the currents induced in the conductor are in such a direction that the reaction between them and the magnetic field opposes the motion.

This law follows at once from the principle of the conservation of energy; for if the forces due to the motion were in any other direction the motion would be increased, and it would only be necessary to start a conductor moving in a magnetic field and its velocity would continually increase, which is contrary to experience.

We can easily see that Lenz's law follows from the electromagnetic

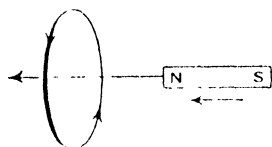

FIG. 252.

effects that we have already studied. For if the magnet and the conducting loop (Fig. 252) approach each other, the induced current in the loop as seen from the magnet is anti-clockwise (Rule II., p. 249), since the induction is increasing. Hence the equivalent magnetic shell has its N polar side towards the magnet, and there is consequently a repulsion between

them. Their relative motion is thus opposed. If the direction of motion is reversed, the effects are all reversed and an attraction results, which is again in accordance with Lenz's law.

A well-known experiment in which a copper disc is caused to rotate underneath a suspended magnet, the magnet then being dragged round in the direction of rotation of the disc, is easily explained by the electromagnetic effects. For the motion of the conductor in the magnet's

¹ Lenz, *Ann. de Phys.*, 31, p. 463. 1834.

field produces currents which tend to prevent the relative motion of the magnet and the disc, and the magnet therefore follows the disc. This is known as Arago's disc experiment.

If the disc were delicately suspended and the magnet caused to rotate, a similar explanation would show that the disc would follow the magnet. This is the principle upon which the polyphase induction motor is founded, a rotating magnetic field produced by alternating currents, causing a closed conductor mounted upon an axle, to rotate in the direction of rotation of the field (p. 374).

Use is made of Lenz's principle in constructing galvanometers of a dead-beat type, in which the suspended needle or coil will quickly come to rest after being disturbed. With an undamped system, the oscillations that occur after every movement, render it exceedingly tedious to measure deflections, or to find the zero position in making Wheatstone's bridge tests. The oscillations are therefore damped out by surrounding the needle by a copper enclosure, the reaction between the induced currents in the enclosure and the needle itself tending to destroy the motion of the needle.

In the case of the suspended coil instrument a copper ring is placed inside the coil, the induced currents in which, as the coil oscillates, quickly bring it to rest. The presence of the ring does not in any way disturb the position of equilibrium when making readings of deflections, unless there are magnetic impurities in it, as the currents only exist when the ring is moving.

When unprovided with a damping ring, the suspended coil may be quickly brought to rest in its zero position by short-circuiting the galvanometer terminals, the induced currents taking place in the coil itself.

Circulation of Charge due to Induced Electromotive Force.—In a closed circuit, the electromotive force produced by the variation of the magnetic flux linked with the circuit, we have seen to be $-\frac{dN}{dt}$. The

current due to this being i , we have $i = -\frac{1}{r} \cdot \frac{dN}{dt}$, where r is the resistance of the circuit. In the interval of time dt , the amount of charge crossing any section of the circuit is $idt = dq$, since,

$$i = \frac{dq}{dt} \quad (\text{see p. 121}).$$

$$\begin{aligned} \therefore dq &= -\frac{1}{r} \cdot \frac{dN}{dt} dt, \\ &= -\frac{dN}{r}. \end{aligned}$$

Therefore the whole charge q passing any section as the magnetic induction linked with the circuit changes from zero to N , is—

$$q = - \int_0^{\infty} \frac{dN}{r} = - \frac{N}{r}.$$

If the induction N is removed from the circuit, the total charge passing any section is $+\frac{N}{r}$. The sign indicates the direction in which the charge passes round the circuit. Its magnitude is in each case $\frac{N}{r}$.

Ballistic Galvanometer—Suspended Magnet Type.—In order to measure the quantity of charge q which passes each point in a closed circuit, a galvanometer is inserted in the circuit. But the instrument

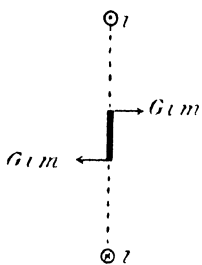

FIG. 253.

must be of a particular type, as it has to integrate the quantity idt , in order to give the charge q . If the suspended needle or coil be free to execute simple harmonic oscillations, then an impulse given to it when at rest in its equilibrium position will set it oscillating, and the amplitude of the oscillation may be taken as a measure of the impulse. The following simple theory determines the relation between the quantity of charge passing through the coil of the galvanometer and the resulting amplitude of oscillation. The method of treatment varies according to the type of instrument. We will

take the suspended magnet form first. Let the current in the coil (Fig. 253) at any instant be i , then the magnetic field at the centre of the coil is Gi , where G is the field at the centre for unit current. The strength of pole of the suspended magnet being m , the force on it is Gim . This, acting for infinitesimal time dt , gives it an impulse $Gimdt$, and from start to finish of the current, the total impulse is—

$$\int_0^T Gimdt = Gm \int_0^T idt.$$

But $\int_0^T idt = q$, the total charge sent round the coil ;

$$\therefore \text{impulse} = Gmq.$$

If half the length of the magnet be l , moment of impulse about the centre is $Gmql$, and for both poles, $2Gmql$.

But $2ml = M$, the magnetic moment of the magnet ;

$$\therefore \text{moment of impulse} = MGq.$$

Consequently this is the angular momentum of the magnet, which, if I be its moment of inertia and ω its angular velocity, is $I\omega$;

$$\therefore GMq = I\omega \quad \dots \quad (i)$$

If we could observe ω , then knowing the constants, G , M , and I , we could calculate q . We cannot, however, observe ω directly, but it may be determined indirectly as follows.

The impulse being over before the needle has rotated appreciably from its position of equilibrium, it possesses kinetic energy $\frac{1}{2}I\omega^2$ while still in the zero position. The needle will rotate until the controlling field brings it to rest, that is, until the work done in opposition to the controlling force is equal to the original kinetic energy. In the enlarged view of the needle in Fig. 254, mH is the controlling force on each pole, and if θ is the angle of deviation when the needle has just lost all its kinetic energy and is on the point of turning back, the work that has been done by the force mH on the pole is—

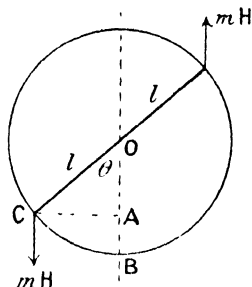

FIG. 254.

$$\begin{aligned}
 & mH \times AB = mHl(1 - \cos \theta), \\
 \text{and for both poles,} & \qquad \qquad \qquad = 2mHl(1 - \cos \theta) \\
 & \qquad \qquad \qquad \qquad \qquad \qquad = MH(1 - \cos \theta), \\
 \therefore MH(1 - \cos \theta) & = \frac{1}{2}I\omega^2 \dots \dots \dots (ii)
 \end{aligned}$$

Eliminating ω from (i) and (ii),

$$\begin{aligned}
 \omega^2 & = \frac{G^2M^2q^2}{I^2} = \frac{2MH(1 - \cos \theta)}{I}, \\
 \therefore q^2 & = MH \cdot \frac{4H^2}{G^2} \cdot \frac{(1 - \cos \theta)}{2} \\
 & = MH \cdot \frac{4H^2}{G^2} \cdot \sin^2 \frac{\theta}{2}.
 \end{aligned}$$

Now the time of oscillation T of the suspended needle, vibrating in the earth's field, has been shown on p. 23 to be given by—

$$T = 2\pi\sqrt{\frac{I}{MH}}, \quad \therefore \frac{I}{MH} = \frac{T^2}{4\pi^2}$$

Hence,

$$\begin{aligned}
 q^2 & = \frac{H^2T^2}{\pi^2G^2} \sin^2 \frac{1}{2}\theta, \\
 q & = \frac{HT}{\pi G} \sin \frac{1}{2}\theta.
 \end{aligned}$$

Ballistic Galvanometer—Suspended Coil Type.—In the case of the suspended coil galvanometer, the force on each vertical side of the coil for current i flowing in it is iHl , where H is the magnetic field due to the permanent magnet (see Fig. 236) and l the length of the vertical

side of the coil. The impulse as before is $\int_0^T iHl dt = Hlq$, and the moment of momentum about the axis of suspension is $Hlbq$, for the two sides, where b is the length of a horizontal side of the coil. The area of the coil is $lb = A$, and therefore the momentum equation is—

$$HAq = I\omega \quad \dots \dots \dots (i)$$

As in the previous case, the kinetic energy is $\frac{1}{2}I\omega^2$, but now the coil is brought to rest by performing work in twisting the suspension.

If c be the restoring couple for unit twist in the suspension fibre, $c\theta$ is the couple for twist θ , and the work done for an additional small twist $d\theta$, is $c\theta d\theta$.

$$\therefore \text{whole work done in twisting suspension} = \int_0^\theta c\theta d\theta = \frac{1}{2}c\theta^2$$

where θ is the deviation of the coil when its kinetic energy $\frac{1}{2}I\omega^2$ is just expended in twisting the suspension.

$$\therefore \frac{1}{2}I\omega^2 = \frac{1}{2}c\theta^2 \quad \dots \dots \dots (ii)$$

$$\omega^2 = \frac{c}{I} \theta^2.$$

From equation (i),

$$\omega^2 = \frac{H^2 A^2 q^2}{I^2}$$

$$\therefore \frac{H^2 A^2 q^2}{I^2} = \frac{c}{I} \theta^2,$$

$$q^2 = \frac{c^2}{H^2 A^2} \frac{I}{c} \theta^2.$$

Now the time of one torsional oscillation of a body of moment of inertia I when c is the couple for unit angle of torsion is—

$$T = 2\pi \sqrt{\frac{I}{c}}$$

$$\therefore q^2 = \frac{c^2 T^2}{4\pi^2 H^2 A^2} \theta^2,$$

and,

$$q = \frac{cT}{2\pi HA} \theta.$$

It will thus be seen that the relation between q and θ is not the same for the two types of galvanometer, the charge passing through the instrument being proportional to the sine of the angle of throw θ in the suspended magnet type, and to the angle θ itself in the suspended coil galvanometer. It should be noted that H in the first case is the controlling field; in the second it is the field to which the deflection is due, and hence it appears in the numerator in the first case and the denominator in the second. These two magnetic fields should not be confused with each other.

Damping.—It never happens that the vibration of the suspended system is simple harmonic; the vibrations always die away, the amplitude getting less and less. This decrease is due to a number of causes, the most important of which are the resistance of the air to the motion of the system, and the electromagnetic damping described on p. 251. On observing successive values of θ to left and right as the needle swings, it will be found that the ratio of one value to the next is a constant. Taking then $\theta_1, \theta_2, \theta_3$, etc., as the succeeding values of θ , we have—

$$\frac{\theta_1}{\theta_2} = \frac{\theta_2}{\theta_3} = \frac{\theta_3}{\theta_4} = \dots = d.$$

This constant ratio d is called the decrement, and $\log_e d$ the logarithmic decrement λ ; therefore $\log_e d = \lambda$ and $d = e^{-\lambda}$. When the oscillation is simple harmonic it may be represented by the projection of a rotating vector OA (Fig. 255) upon any fixed straight line, say OB . In this case succeeding amplitudes are OB, OB', OB'' , etc.; but if the amplitudes get less in a constant ratio, we must imagine the rotating vector OA to shrink at a constant rate, and it will be seen from the diagram that the shrinkage from θ_1 to θ_2 takes place in half a vibration. If there were no damping, the amplitude would all the time have been $\theta = OA$; and since the impulse was given to the system when in its middle position, that is the position corresponding to OA , the shrinkage of the vector that has actually occurred, before the first throw θ_1 is observed, has taken place during a quarter of a vibration.

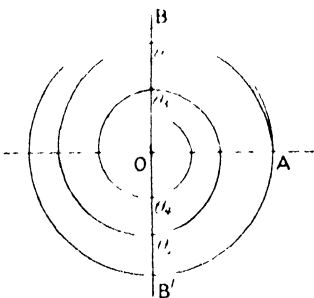

FIG. 255.

Now, for half a vibration, shrinkage is—

$$\frac{\theta_1}{\theta_2} = \frac{\theta_2}{\theta_3} = \frac{\theta_3}{\theta_4} = \dots = e^{-\lambda},$$

and for a whole vibration $\frac{\theta_1}{\theta_2} = e^{-2\lambda}$, and so on, the shrinkage being proportional to the power of e ; and hence for a quarter vibration it is $e^{-\frac{\lambda}{2}}$. Therefore $\frac{\theta}{\theta_1} = e^{-\frac{\lambda}{2}}$,

$$\theta = \theta_1 e^{-\frac{\lambda}{2}} = \theta_1 \left(1 + \frac{\lambda}{2} + \frac{\lambda^2}{4 \cdot 2} + \frac{\lambda^3}{8 \cdot 3} + \dots \right).$$

Since d must always be nearly equal to unity for a ballistic

galvanometer, λ is always very small, and λ^2 and the higher powers of λ may be neglected.

$$\therefore \theta = \theta_1 \left(1 + \frac{\lambda}{2} \right).$$

Thus we can correct for the damping of the needle, although we cannot avoid it, and the equation for the two types of ballistic galvanometer will then be—

$$q = \frac{HT}{\pi G} \sin \frac{1}{2} \theta \left(1 + \frac{\lambda}{2} \right),$$

and,
$$q = \frac{c\Gamma}{2\pi HA} \theta \left(1 + \frac{\lambda}{2} \right).$$

If great accuracy is not required, the undamped throw may be obtained from the damped throw by multiplying it by \sqrt{d} , where d is the decrement, obtained by observing two consecutive elongations.

$$\text{For, } \frac{\theta}{\theta_1} = \epsilon^{\frac{\lambda}{2}}, \quad \therefore \left(\frac{\theta}{\theta_1} \right)^2 = \epsilon^\lambda = d,$$

$$\text{and, } \theta = \theta_1 \sqrt{d}.$$

The advantage in the longer method lies in the fact that a great number of swings may be taken to determine λ , for if θ_1 and θ_{11} are observed, 10 half-vibrations occur between the observations—

$$\frac{\theta_1}{\theta_{11}} = \epsilon^{10\lambda}, \quad \therefore \lambda = \frac{1}{10} \log_{\epsilon} \frac{\theta_1}{\theta_{11}}.$$

Calibration of Ballistic Galvanometer.—In using the ballistic

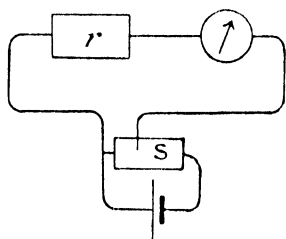

FIG. 256.

galvanometer to compare charges, or magnetic fluxes, the ratio only of the two respective throws is required, and the constants occurring in the equations need not be found. If however the charge or the flux is required in absolute measure, we must by some means determine these constants. The most convenient method is to pass a steady current through the galvanometer by means of a standard cell, a high resistance being included in the circuit. If a sufficiently high resistance

is not available, a known fraction of the electromotive force of the cell may be obtained by means of a resistance box used as a shunt S (Fig. 256). If then the effective electromotive force applied to the galvanometer circuit be e , and r the resistance of the circuit,

$$\text{current } i = \frac{e}{r}.$$

Then in the case of the suspended magnet galvanometer there will be a steady deflection θ_1 , where $\frac{Gi}{H} = \tan \theta_1$, that is, $\frac{Ge}{rH} = \tan \theta_1$,

$$\therefore \frac{G}{H} = \frac{r \tan \theta_1}{e},$$

and the equation for q , on p. 253 becomes—

$$q = \frac{eT}{\pi r} \cdot \frac{\sin \frac{1}{2}\theta}{\tan \theta_1},$$

which may be written $q = \frac{eT}{2\pi r} \cdot \frac{\theta}{\theta_1}$, when θ and θ_1 are small.

For the suspended coil galvanometer, the steady deflection θ_1 is given by $iAH = c\theta_1$ (p. 241), i.e. $\frac{e\Lambda H}{r} = c\theta_1$, and substituting $\frac{r\theta_1}{e}$ for $\frac{AH}{c}$ in the equation for q on p. 254, we have $q = \frac{eT}{2\pi r} \cdot \frac{\theta}{\theta_1}$.

We see that when the calibration is performed in this way we are led to identical equations for the quantity of charge passing through the galvanometer with both types of instrument. T is determined by observing the time for a number of complete oscillations.

Capacities.—If the condenser C be charged by means of the cell of electromotive force e_1 , the charge on the condenser will be $e_1C = q$, and if this be sent through the ballistic galvanometer, we have from the last equation—

$$e_1C = q = \frac{eT}{2\pi r} \cdot \frac{\theta\left(1 + \frac{\lambda}{2}\right)}{\theta_1}, \text{ or, } C = \frac{eT}{2\pi r e_1} \cdot \frac{\theta\left(1 + \frac{\lambda}{2}\right)}{\theta_1}.$$

If the electromotive force e_1 used for charging the condenser be the same as e , that used in calibrating the galvanometer, the expression for the capacity becomes $C = \frac{T}{2\pi r} \cdot \frac{\theta}{\theta_1}$. It should be noted that if the resistance is given in ohms, C will be in farads (see p. 396).

The charge and discharge key K (Fig. 257) is a useful one; on depressing it the condenser is charged, and on releasing it, first one end of the battery is insulated, and then the galvanometer circuit is closed so that the condenser is discharged through it.

When a comparison of two capacities merely is wanted, it is not necessary to calibrate the galvanometer; we obtain a throw θ_1 by discharging the first condenser C_1 through the

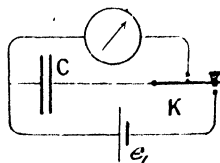

FIG. 257.

galvanometer, having previously charged it by means of a cell of electromotive force e_1 (Fig. 257), and then repeat the process for the second condenser C_2 , obtaining the throw θ_2 .

Then $C_1 = k\theta_1$, and, $C_2 = k\theta_2$,

$$\therefore \frac{C_1}{C_2} = \frac{\theta_1}{\theta_2},$$

since the other quantities in the multiplier ($k = \frac{HT}{\pi C_1}$, or, $k = \frac{cT}{2\pi AII}$) are constant, and therefore k is constant.

If one of the capacities be a standard, and the cell have known electromotive force, the instrument may be calibrated by finding the constant k from the relation $q = eC = k\theta$, but it should be noticed that the constant determined in this way may only be used when the galvanometer is on open circuit. When the circuit is closed, the resistance is not the same, and in general the time of oscillation T will be altered.

Resistance by Method of Damping.—In the case of a ballistic galvanometer, the resistance to the motion of the moving part when the circuit is open, is due to air friction, viscosity in the fibre, and to the induced currents in any neighbouring masses of metal. This whole effect is very small in a well-designed instrument, and we may consider the effect to be a couple, whose value at any instant is proportional to the angular velocity, and may therefore be written $p \cdot \frac{d\theta}{dt}$, which opposes the motion of the suspended part. When, however, the circuit is closed, the motion of the suspended needle causes the coil to be cut by a magnetic flux, and a current to be induced in it proportional to the angular velocity, and inversely as the resistance of the coil, and the reaction between this and the permanent field gives rise to a retarding couple which we may write $\frac{m}{R} \cdot \frac{d\theta}{dt}$, where m is a constant involving the magnetic flux due to the magnet and the area of the coil.

The equation of motion of the suspended part may then be written—

$$I \frac{d^2\theta}{dt^2} + \left(\frac{m}{R} + p \right) \frac{d\theta}{dt} + c\theta = 0,$$

where I is the moment of inertia of the moving part, and c the controlling couple per unit deflection when this is small.

Thus,
$$\frac{d^2\theta}{dt^2} + \frac{1}{I} \left(\frac{m}{R} + p \right) \frac{d\theta}{dt} + \frac{c}{I} \theta = 0,$$

or,
$$\frac{d^2\theta}{dt^2} + 2b \frac{d\theta}{dt} + k^2\theta = 0,$$

when, $\frac{1}{I} \left(\frac{m}{R} + p \right) = 2b$, and, $\frac{c}{I} = k^2$.

The solution of which is (see p. 337)—

$$\theta = A\epsilon^{-bt} \cos \sqrt{k^2 - b^2} t.$$

Thus the elongation θ_0 when $t = 0$, is A ; and θ_1 when $t = \frac{\pi}{\sqrt{k^2 - b^2}}$

is $-A\epsilon^{-b\frac{\pi}{\sqrt{k^2 - b^2}}}$, and so on. Successive elongations being in opposite directions, the opposite signs of alternate elongations will be omitted, and we have—

$$\theta_0 = \frac{1}{\epsilon^{-b\frac{\pi}{\sqrt{k^2 - b^2}}}}, \quad \theta_1 = \frac{\epsilon^{-b\frac{\pi}{\sqrt{k^2 - b^2}}}}{\epsilon^{-b\frac{2\pi}{\sqrt{k^2 - b^2}}}} = \frac{1}{\epsilon^{-b\frac{\pi}{\sqrt{k^2 - b^2}}}},$$

$$\therefore \frac{\theta_0}{\theta_1} = \frac{\theta_1}{\theta_2} = \frac{\theta_2}{\theta_3} = \epsilon^{\frac{b\pi}{\sqrt{k^2 - b^2}}} = d.$$

Thus, $\log_e d = \lambda = \frac{b\pi}{\sqrt{k^2 - b^2}} = \text{logarithmic decrement.}$

Now, for the galvanometer to be ballistic, b must be small in comparison with k , so that we have—

$$\begin{aligned} \lambda &= \frac{b\pi}{k} = \pi \frac{1}{2I} \left(\frac{m}{R} + p \right) \sqrt{\frac{I}{c}} \\ &= a \left(\frac{1}{R} + p_1 \right), \end{aligned}$$

where $p_1 = \frac{p}{m}$, and a is a new constant.

Let the logarithmic decrement λ_0 be determined with the galvanometer on open circuit; then $R = \infty$,

and, $\lambda_0 = ap_1$.

Again, let it be determined with the galvanometer short-circuited, R_g being the resistance of the galvanometer itself.

Then, $\lambda_g = a \left(\frac{1}{R_g} + p_1 \right)$,

and again, with a total resistance R in circuit—

$$\lambda_R = a \left(\frac{1}{R} + p_1 \right).$$

Subtracting λ_R from λ_g we get—

$$\lambda_g - \lambda_R = a \left(\frac{1}{R_g} - \frac{1}{R} \right).$$

Subtracting λ_0 from λ_R we get—

$$\lambda_R - \lambda_0 = \frac{a}{R}.$$

Now, dividing the last equation but one by the last—

$$\frac{\lambda_g - \lambda_R}{\lambda_R - \lambda_0} = \frac{R - R_g}{R_g}.$$

$R - R_g$ is the resistance added for the third determination, and hence it can be found in terms of R_g or *vice versa*.

This method must be modified in the case of a moving coil galvanometer, for on short-circuiting the coil, the motion becomes dead beat; but two high resistances may be compared; for if R_1 and R_2 be the total resistances, including that of the galvanometer, and λ_1 and λ_2 the corresponding logarithmic decrements—

$$\begin{aligned}\lambda_0 &= ap_1, \\ \lambda_1 &= a\left(\frac{1}{R_1} + p_1\right), \\ \lambda_2 &= a\left(\frac{1}{R_2} + p_1\right),\end{aligned}$$

From which as before—

$$\begin{aligned}\lambda_1 - \lambda_2 &= \frac{R_2}{R_1} - 1, \\ \lambda_2 - \lambda_0 &= \frac{R_2}{R_1} - 1, \\ \text{or, } \frac{R_2}{R_1} &= \frac{\lambda_1 - \lambda_0}{\lambda_2 - \lambda_0}.\end{aligned}$$

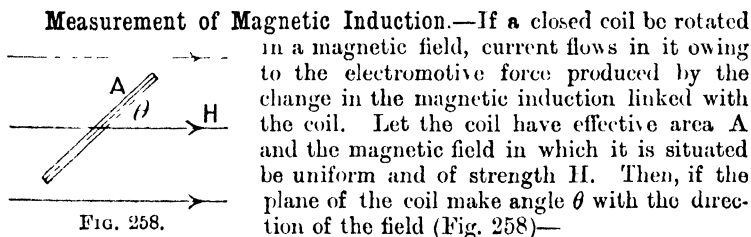

magnetic induction linked with coil = $HA \sin \theta = N$.

Hence, as the coil rotates—

$$e = -\frac{dN}{dt} = -\frac{d(HA \sin \theta)}{dt},$$

and at each instant the current i is $\frac{e}{r}$.

$$\therefore i = -\frac{HA}{r} \cdot \frac{d(\sin \theta)}{dt},$$

or,

$$idt = -\frac{HA}{r} d(\sin \theta).$$

If, then, $\theta = \frac{\pi}{2}$ at time $t = 0$; and $-\frac{\pi}{2}$ at the end of an interval of time t —

$$\int_0^t i dt = q = -\frac{H\Lambda}{r} \int_{\theta = \frac{\pi}{2}}^{\theta = -\frac{\pi}{2}} d(\sin \theta),$$

$$= -\frac{H\Lambda}{r} \left[\sin \theta \right]_{\frac{\pi}{2}}^{-\frac{\pi}{2}} = \frac{2H\Lambda}{r}.$$

If, then, the coil is in series with the ballistic galvanometer, calibrated in the usual way—

$$\frac{2H\Lambda}{r} = k\theta,$$

or,
$$H = \frac{rk}{2\Lambda} \theta,$$

where k is the constant determined by the ordinary method (p. 257).

When H is the horizontal component of the earth's magnetic field, the coil is known as the *Earth Inductor*, Fig. 259, and the method may be used for determining H . On the other hand, if H be accurately known, the method is a convenient one for calibrating the ballistic galvanometer.

Care must be taken that before and after rotation, the coil shall be at right angles to the meridian, as otherwise the charge passing round the coil is less than $\frac{2H\Lambda}{r}$. The correct position is that in which a maximum throw is obtained for a sudden rotation of the coil through 180° .

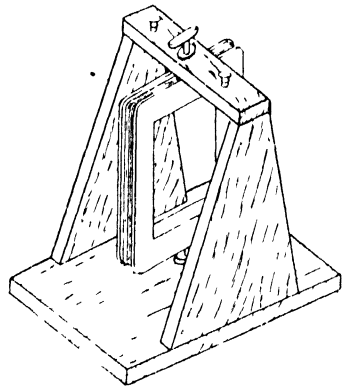

FIG. 259.

The vertical component of the earth's field may be found by laying the apparatus on its side so that the coil is horizontal before and after rotation. Then $V = \frac{rk}{2\Lambda} \theta_v$, and the dip may be found by taking the ratio of the throws produced in the two positions—

$$H = \frac{rk}{2A} \theta_H, \quad V = \frac{rk}{2A} \theta_V,$$

$$\tan(\text{dip}) = \frac{V}{H} = \frac{\theta_V}{\theta_H}.$$

It should be noticed that in measuring a magnetic flux, the total amount of charge caused to circulate in the circuit is $\frac{N}{r}$, where r is the resistance of the circuit, and consequently to get the greatest effect on the galvanometer, r should be as small as possible. With the suspended coil galvanometer, r must not be indefinitely reduced, for this would have the effect of rendering the galvanometer dead beat, whereas the relation between charge and throw depends on it being ballistic. Hence for the measurement of small values of the flux it is desirable to use a suspended magnet galvanometer, which, even when short-circuited, is usually sufficiently ballistic for the purpose. For large values of the flux, a suspended coil galvanometer may be used, a high resistance being put into the circuit without unduly diminishing the sensitiveness; in fact, for measurements of magnetic permeability (p. 274) it is generally necessary to reduce the sensitiveness in this way, the additional advantage of rendering the galvanometer ballistic being attained.

In the measurement of capacity no such difficulty arises, for the amount of charge caused to pass through the galvanometer is independent of the resistance of the circuit. Hence the greater the number of turns in the coil of the galvanometer the better, and the sensitiveness of a high-resistance galvanometer is therefore greater than that of one of low resistance.

Standards of Magnetic Flux.—Standard magnetic fluxes are very useful for the calibration of ballistic galvanometers. One form of such standard consists of a long solenoid, on the middle part of which is wound a secondary coil of a great many turns.

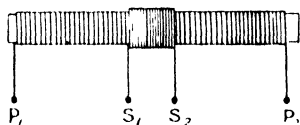

FIG. 260.

If the solenoid have n_1 turns per centimetre length, the magnetic field in the interior when a current i absolute units flows in it is $4\pi n_1 i$ (p. 229). If then A be the mean area of section of

the solenoid, the total magnetic flux across any section far removed from the end is $4\pi n_1 i A$. If the secondary coil has n_2 turns the effective amount of magnetic flux linked with it is $4\pi n_1 i A n_2$. This flux enters it on establishing the current in the solenoid, and leaves it on stopping the current, and if the ballistic galvanometer be connected to the secondary terminal $S_1 S_2$ (Fig. 260), the charge caused to circulate through the galvanometer on starting or stopping the current is $\frac{4\pi n_1 n_2 A i}{r}$ absolute units, where r is the resistance of the circuit. Since

all these quantities are easily measurable, the method is a convenient one for calibrating the galvanometer.

Another convenient source of flux is the Hibbert magnetic standard (Fig. 261). A block of hard steel has a cylindrical slot cut in it. The steel is magnetised so that the magnetic flux cuts radially across the slot. A circular coil C wound on a hollow brass cylinder can be dropped into the slot, and in doing so cuts the magnetic flux due to the cylindrical magnet. The number of magnetic lines must in the first instance be determined by comparison with some such standard as that last described, and it is found that owing to the form of the permanent magnet the flux remains very constant and forms a useful and easily employed standard.

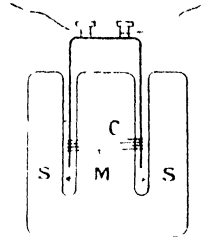

FIG. 261.

Grassot Fluxmeter.—The passage of the electric charge through the ballistic galvanometer must have ceased before the moving system has moved appreciably, or the impulse will not be applied to the system in its position of equilibrium, and our equations no longer apply. For measuring magnetic fluxes, the Grassot fluxmeter has the great advantage over the ballistic galvanometer, that the change in flux need not take place instantaneously, or at any particular rate, the moving coil being at rest before and after the change, the difference in position being proportional to the change in flux linked with the circuit. This result is attained by reducing to a very small amount all sources of damping other than that due to the electromagnetic effect between the permanent field and the coil as it rotates, until this becomes the predominating control. The coil BB (Fig. 262) is suspended by a single silk fibre attached to the spiral R to prevent damage from shocks. The current enters and leaves the coil by two fine silver spirals, S and S'. The mechanical control is thus very small, and the damping due to the air resistance to motion is usually insignificant, so that the only effective damping is that due to the induced current in the coil as it rotates, in fact the period of oscillation of the coil on open circuit is of the order of a minute.

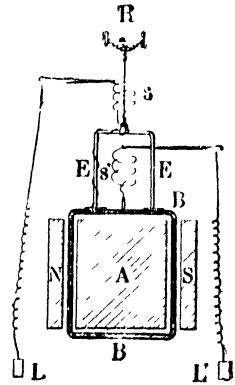

FIG. 262.

The terminals L and L' are connected to an exploring coil, the variation in flux through which, it is required to determine. If the effective area of the exploring coil be known, the magnetic induction can be calculated from the flux ($N = BA$). With the exploring coil connected, the total resistance is of the order of 20 ohms, and the coil will remain practically at rest in any position.

When the flux through the exploring coil changes, there will be an electromotive force acting in the circuit, and consequently a current in it, whose value is $\frac{e}{r} = i$, where r is the resistance of the circuit and e the resultant electromotive force. The coil therefore experiences a couple iAH , A being the effective area of the galvanometer coil and H the field due to the permanent magnet.

$$\therefore iAH = I \frac{d\omega}{dt}$$

where I is the moment of inertia of the moving coil and ω its angular velocity, so that $\frac{d\omega}{dt}$ is its angular acceleration.

$$\text{Then,} \quad \frac{eAH}{r} = I \frac{d\omega}{dt} \dots \dots \dots (i)$$

Now e is the difference between the electromotive force due to rate of change of flux in the exploring coil $\left(\frac{dN}{dt}\right)$ and that in the galvanometer coil due to its rotation with angular velocity ω in the field of the permanent magnet. The latter is $AH\omega$, or $AH \frac{d\theta}{dt}$, where θ is the angle the coil makes with its mean position.

$$\text{Thus,} \quad e = \left(\frac{dN}{dt} - AH\omega \right),$$

$$\text{and from (i),} \quad \frac{AH}{r} \left(\frac{dN}{dt} - AH \frac{d\theta}{dt} \right) = I \frac{d\omega}{dt}.$$

Integrating, we have—

$$AH \int_0^t \left(\frac{dN}{dt} - AH \frac{d\theta}{dt} \right) dt = I \int_0^t \frac{d\omega}{dt} dt.$$

Now the last integral is $\left[\omega \right]_{t=0}^{t=t}$, and since the coil is at rest before and after the change in flux, both these limiting values of ω are zero.

$$\therefore \int_0^t \left(\frac{dN}{dt} - AH \frac{d\theta}{dt} \right) dt = 0,$$

$$\text{or,} \quad \left[N \right]_0^t - AH \left[\theta \right]_0^t = 0.$$

$$\text{i.e.} \quad N = AH\theta = k\theta,$$

where N is the total change in magnetic flux linked with the exploring coil, and θ is the corresponding change in position of the suspended coil. This relation is independent of the time during which the change in flux takes place. Thus to measure a flux, all that is necessary is to put the exploring coil into the space in which the flux is required, in performing which action the coil cuts the flux to be measured, and the displacement of the galvanometer coil measures at once this flux. The coil is provided with a pointer moving over a scale so calibrated that with an exploring coil of definite resistance the flux for one division of the scale is known. A mirror is also attached to the moving system, so that by means of the deflection of a spot of light, very small magnetic fluxes may be measured, but in this case the scale must be calibrated by using a known flux to determine the constant k in the expression $N = k\theta$.

CHAPTER X

MAGNETIC PROPERTIES OF MATERIALS

Theories of Magnetisation.—Passing over the early theories of magnetisation, which accounted for the phenomena by the existence of two magnetic fluids (Coulomb), and others by means of vortices (Descartes), we come to the first approach to a molecular theory, due to Poisson, who supposed that the magnetic materials contained small spheres which are conductors of the magnetic fluids, and in a magnetic field behave in an analogous manner to that of conducting spheres in an electric field. The next advance was due to Weber, who assumed that the molecules of a magnetic substance are themselves permanent magnets, and that in the act of magnetisation they are turned into the direction of the magnetising field. In order to account for the fact that a field, however weak, will not set all the molecular magnets parallel to the field, and therefore produce saturation, a mechanical restraint opposing their rotation was postulated. Prof. J. A. Ewing added to the molecular theory by showing that the magnetic interaction between the molecules themselves is sufficient to account for the known behaviour of magnetic materials. Ewing's theory will be considered more in detail later, but we shall take the molecular hypothesis as fully established.

Intensity of Magnetisation and Magnetic Susceptibility.—We define the intensity of magnetisation (I) of a magnetised material as the *ratio of the magnetic moment to the volume of any piece of it*, the piece being sufficiently small for us to consider its magnetisation uniform.

$$\text{Thus,} \quad I = \frac{\text{magnetic moment}}{\text{volume}}$$

If a rectangular piece of the material (Fig. 263) have length l parallel to the direction of magnetisation and cross-section a , then if σ is the amount of pole per unit area of each end, we have, when the magnetisation is uniform,—total pole at each end is $a\sigma$, and the magnetic moment is $la\sigma$. But the volume is la ,

$$\therefore I = \frac{la\sigma}{la} = \sigma.$$

Thus the intensity of magnetisation may also be defined as the amount of pole per unit area taken at right angles to the direction of magnetisation.

If the volume taken be situated in the interior of a magnetised body, σ is not free pole, in the sense that it produces an outside effect, for it is situated indefinitely close to an equal and opposite amount of pole upon the adjacent layer. It is only where the magnetic poles form the outside layer of the material that their effects are not balanced by

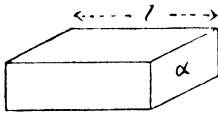

FIG. 263.

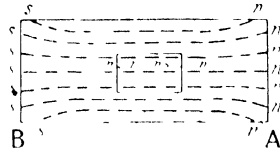

FIG. 264.

that of opposite poles, and the ordinary polar phenomena are produced, as at A and B (Fig. 264).

The ratio of the intensity of magnetisation (I) at any point within a body to the magnetic field (H) to which it is due is called the magnetic susceptibility (k) of the material. Thus $k = \frac{I}{H}$.

Induction within a Magnetic Material.—The magnetic induction (B) has already been defined on p. 234 as the product μH , where H is the strength of magnetic field, and μ the permeability, which we have seen is defined from the relation $F = \frac{m_1 m_2}{\mu r^2}$, for the force between poles situated within the material. We will now obtain the value of B in terms of I and H.

On placing a bar of unmagnetised material in a uniform magnetic field, the material becomes a magnet on account of the rotation of its molecules into alignment with the field, and if the resultant of the field produced by the magnet and the original field be found for every point, we have then obtained the field actually existing. For external points there is no difficulty when the field due to the magnet is known; at points such as l and f (Fig. 265) the field is strengthened, and at g and h it is weakened. Within the material, let us imagine a surface AB of unit area, drawn at right angles to the direction of magnetisation, in the interspaces between the molecules. If the intensity of magnetisation be I, the amount of pole on each side of the area is also I (see above),

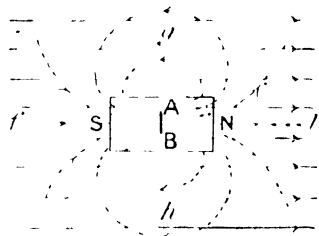

FIG. 265.

N pole on one side and S pole on the other. The field in this interspace due to each polar surface is $2\pi I$ (see p. 234) in the direction of magnetisation, and due to the two together it is $4\pi I$. Thus the magnetic induction (which is also the magnetic field in the interspaces where μ is unity) over this unit area is H , together with $4\pi I$ due to the resulting magnetisation, and the total B , or μH , is the sum of these two.

$$\therefore B = H + 4\pi I.$$

It is this induction B , or μH , whose surface integral over a closed surface is, according to Gauss's theorem, equal to 4π times the total magnetic pole within the surface.

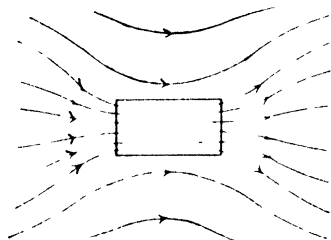

FIG. 266.

The magnetisation contributes to the induction; but owing to the proximity of the molecular N and S poles to each other, it does not contribute to the force on a pole of finite size situated in the medium. The resultant state of affairs may now be represented on a diagram by drawing the resultant induction everywhere. In the space outside the magnetic material the problem resembles that for a bar magnet placed in a uniform field, and we are assisted in completing the drawing for the interior of the material, by remembering that the induction inside is continuous with that outside. The last diagram now becomes modified to the approximate form shown in Fig. 266. A similar diagram for a sphere is shown in Fig. 153.

On dividing the last equation through by H we have—

$$\frac{B}{H} = 1 + 4\pi \frac{I}{H},$$

that is,

$$\mu = 1 + 4\pi k.$$

Thus, if by any experimental means k be determined, μ may be calculated, and *vice versa*.

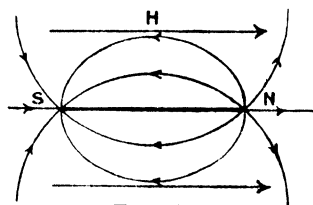

FIG. 267.

Demagnetisation. — It must be understood that H in the above expression is the actual field producing magnetisation within the material, and that if there are free poles upon the specimen they will always produce a field which is in opposition to, and must be subtracted from, the original field, within the material, to obtain the resultant magnetising effect. Thus,

for a magnet NS (Fig. 267) each pole produces its own radial field, the resultant being the ordinary field due to a pair of poles. At the middle of the magnet this field is opposed to the magnetising field H ,

and therefore exerts a demagnetising effect upon the bar. It is for the purpose of removing the free poles that produce this demagnetising effect, that permanent magnets are usually provided with soft-iron keepers, the keeper producing poles equal and opposite to those of the magnet, and being very nearly coincident in position with them, these poles produce a field equal and opposite to the demagnetising field.

Whatever the form of the magnet, the demagnetising field is proportional to the strength of the pole to which it is due, and this in turn is proportional to the intensity of magnetisation, so that the demagnetising field is equal to NI , where N is a constant depending on the geometrical form of the magnetised body.

If then H' is the magnetising field when the body is absent, and H that actually existing in the interior of the body—

$$H = H' - NI.$$

N may be calculated in a number of simple cases when the interior field is uniform, but this is not in general the case. On p. 235 we saw that the resultant field inside a sphere of permeability μ_2 situated in a material of permeability μ_1 is $\frac{3\mu_1}{\mu_2 + 2\mu_1}$ times the external field. If now we consider a sphere of iron of permeability μ situated in air, the resultant interior field is $\frac{3}{2 + \mu}$ times the original field, that is—

$$H = \frac{3}{2 + \mu} H'.$$

Remembering that,
and that,
we then have,

$$\begin{aligned} \mu &= 1 + 4\pi k, \\ I &= kH, \\ H &= H' - 4\pi I, \end{aligned}$$

from which we see that for a sphere, $N = \frac{1}{3}\pi$. Thus, with the value $\mu = 1000$ —

$$H = \frac{3}{1002} H',$$

and since $B = \mu H$ —

$$B = \frac{3000}{1002} H' = 3H' \text{ approximately.}$$

If there were no demagnetisation effect, B would have been $1000 H'$; and hence the important part played by the free polar surfaces in this case.

The effect is greatest for a magnetic sheet perpendicular to the field. In this case the surface condition (ii.), p. 234, tells us that $B = H'$ (Fig. 268).

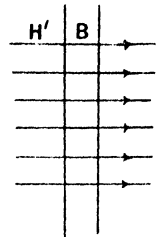

FIG. 268.

Further, $B = \mu H$, $\therefore H = \frac{H'}{\mu}$.
But, $\mu = 1 + 4\pi k$, $\therefore H(1 + 4\pi k) = H'$,
 $H = H' - 4\pi I$.
 $\therefore N = 4\pi$.

For a permeability of 1000, the actual field inside the sheet is only $\frac{1}{1000}$ of that outside.

In the case of a *very long wire parallel to the field*, the demagnetisation effect throughout the greater part of the length of the wire is negligible, owing to the distance away of the poles at the ends. When the wire is not very long, Ewing¹ treated it as an ellipsoid with the axis parallel to the field of much greater length than the axes perpendicular to the field.

For an ellipsoid having semi-axes, a , b and c , when c is the long axis, parallel to the field, and $a = b = \sqrt{1 - e^2} c$, it is shown in "Maxwell's Treatise on Electricity and Magnetism," vol. ii., that—

$$N = 4\pi \left(\frac{1}{e^2} - 1 \right) \left(\frac{1}{2e} \log \frac{1 + e}{1 - e} - 1 \right),$$

and using this equation, the values of N corresponding to different values of $\frac{c}{a}$, or ratio of length to diameter of the wire, are calculated—

length diameter	N.
50	0.01817
100	0.00540
200	0.00157
300	0.00075
400	0.00045
500	0.00030

Thus for a wire of length equal to 500 times its diameter—

$$H = H' - 0.00030I,$$

or,

$$\frac{H'}{H} = 1 + 0.00030k.$$

k does not often exceed 200, and for this value—

$$\frac{H'}{H} = 1.06.$$

Thus, the field is reduced about 6 per cent. by the free poles. The magnitude of the effect shows that in measuring the susceptibility of an iron wire, it is usually necessary to correct the magnetising field for the demagnetising effect of the free poles upon the specimen.

¹ J. A. Ewing, "Magnetic Induction in Iron and other Metals."

Practical Methods.—(i) *Magnetometer.* For material in the form of a wire, the magnetometer, as developed by Ewing,¹ is usually employed in studying the magnetic properties. The specimen is placed vertically inside a magnetising solenoid, with its upper pole on a level with the needle of the magnetometer of the type shown in Fig. 7. If then a be the area of cross-section of the wire, the strength of pole at each end

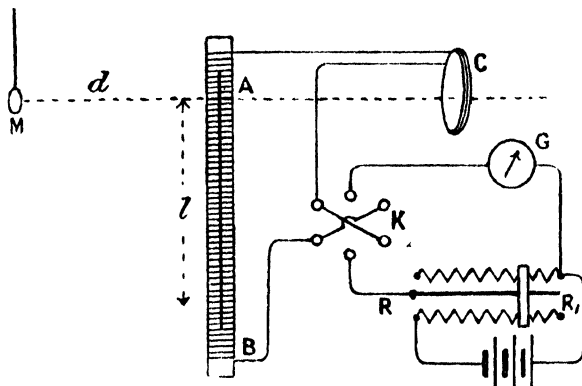

FIG. 269.

is Ia , when intensity of magnetisation is I , and the strength of field at the magnetometer needle M due to the pole A is $\frac{Ia}{d^2}$ (Fig. 269). That due to the pole B is $-\frac{Ia}{d^2 + l^2}$, the horizontal component of which is $-\frac{Ia \cdot d}{(d^2 + l^2)^{3/2}}$, and the resulting horizontal field due to the specimen is $Ia \left\{ \frac{1}{d^2} - \frac{d}{(d^2 + l^2)^{3/2}} \right\}$. When this is at right angles to the controlling field f , then the deflection θ , is given by—

$$Ia \left\{ \frac{1}{d^2} - \frac{d}{(d^2 + l^2)^{3/2}} \right\} = f \tan \theta.$$

If the specimen is very long the term $\frac{d}{(d^2 + l^2)^{3/2}}$ is small, but in any case it may be calculated. The effective length l is about three-quarters of the length of the wire. If the controlling field f be known, I can then be found in terms of the deflection θ . The magnetising field H' is known in terms of the current i in the magnetising solenoid; n being the number of turns per centimetre length of coil, $H' = 4\pi ni$, where i is in absolute units.

¹ J. A. Ewing, "Magnetic Induction in Iron and other Metals."

There are several disturbances to be allowed for. In the first place the solenoid produces a magnetic field at the magnetometer. This effect is eliminated by placing the vertical circular coil C, whose axis passes through A and M, in series with the solenoid and adjusting its distance from M, with the specimen removed, until on passing the current the magnetometer needle is undisturbed. This balance, if perfect for one current, holds for all currents, and the disturbing effect of the solenoid on the needle is then eliminated. The coil C serves another useful purpose, for if we disconnect the solenoid and observe the deflection θ_1 produced by a current i_1 in C, we can obtain the value of the controlling field f . Calling the distance of M from C, x , the field at M due to the current in C is $\frac{2\pi na^2 i_1}{(a^2 + x^2)^{3/2}}$ (see p. 228), where n is the number of turns in C.

$$\therefore \frac{2\pi na^2 i_1}{(a^2 + x^2)^{3/2}} = f \tan \theta_1,$$

from which f can be found.

The second disturbance is due to the fact that the specimen is always magnetised by the vertical component of the earth's magnetic field. To eliminate this effect a second solenoid is wound upon the first (not shown in the diagram) and the current in it adjusted until, on demagnetising the specimen, the magnetometer needle remains in its true zero position when there is no magnetising current. This earth neutralising current is maintained constant during the experiment.

Having made all the adjustments, a series of values of θ and i is observed, beginning with the slider of the rheostat in the position R_1 , so that the value of the magnetising current is small. The current is then increased step by step to a maximum by moving the contact from R_1 to R , θ and i being observed at each step. The current is then diminished in a similar manner to zero, then reversed by means of the key K, increased to a negative maximum, diminished to zero, and finally reversed and increased to its original positive maximum. The series of readings of θ and i are then converted by constant factors, determined as above described, into the corresponding values of l and H' , which may then be plotted in the form of a curve. In the case of the ordinary reflecting magnetometer, the deflection is usually sufficiently small to use θ instead of $\tan \theta$, without appreciable error.

Then—

$$I = \frac{2\pi na^2 i_1}{(a^2 + x^2)^{3/2} \theta_1} \cdot \left\{ \frac{1}{d^2} - \frac{d}{(d^2 + l^2)^{3/2}} \right\}^{-1} \cdot \frac{l}{a} \cdot \theta.$$

$$H' = 4\pi ni.$$

If the currents are measured in amperes, each of these expressions must be divided by 10.

The dotted curve H' for a specimen of steel piano wire is shown in Fig. 270. To obtain the curve connecting I and H from this, the demagnetisation effect is to be allowed for. To do this the line Oq is drawn through the origin, making angle pOq such that the $\tan pOq = N$. But $H = H' - NI$. Then,

$$pq = Op \tan(pOq) = Op \cdot N = NI.$$

Thus, $pq = H' - H$, and drawing $ef = pq$, horizontally from the point e of the H' curve, we get the corresponding point f on the H curve. The whole curve is then corrected in the same way. This is equivalent to shearing the H' curve through an angle $\tan^{-1} N$ to obtain the true H curve, and obviates the necessity of calculating the demagnetisation effect $H' - H$ or NI for every reading.

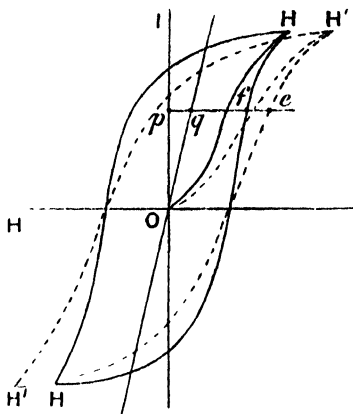

FIG. 270.

(ii) *Ballistic Method.*—In this method the total magnetic flux in the material is measured by means of the ballistic galvanometer. The material in the form of a ring, usually of circular cross-section, is wound uniformly with an endless solenoid which produces an approximately uniform magnetising field $\frac{4\pi n_1 I}{10}$ (p. 232), where the current I in it is measured by the ammeter A .

A secondary coil of n_2 turns (Fig. 271) is also wound upon the ring, and is cut by the magnetic flux Ba , on establishing the magnetising field, B being the magnetic induction in the material, and a the area of cross-section of the ring. In series with the secondary coil is a ballistic galvanometer G . The charge caused to circulate in the

galvanometer is then $\frac{Ban_2}{R}$, where R is the resistance of the secondary

circuit, and if θ be the galvanometer throw, $\frac{Ban_2}{R} = k\theta$. k is determined by means of the standard flux produced by the straight solenoid n_3 , and its secondary n_4 (p. 262), and if θ_1 be the throw produced by establishing current I_1 in this standardising solenoid—

$$\frac{4\pi n_3 I_1 A n_4}{10R} = k\theta_1,$$

The two secondaries n_2 and n_4 being permanently in series with the galvanometer, R is the same in both cases, and therefore, eliminating k from the last two equations, we have—

$$B = \frac{4\pi n_3 n_4 \Delta I_1}{10 a n_2 \theta_1} \theta.$$

From this and the equation—

$$H = \frac{4\pi n_1}{10} I,$$

the ballistic throws θ , and the ammeter readings I , may be converted into the corresponding values of B and H .

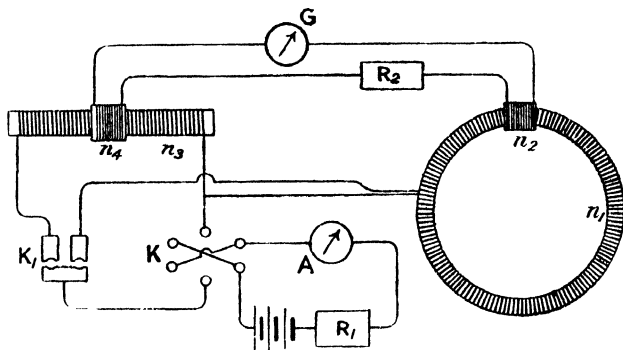

FIG. 271.

From an inspection of Fig. 272 it will be seen that on establishing a field Oh , and then removing it, the reverse throw on removal will be

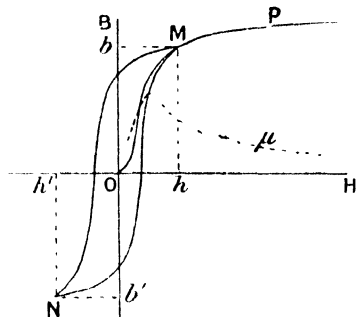

FIG. 272.

less than the direct throw on producing it, since a large fraction of the magnetisation remains; in fact, the throw obtained on establishing or removing the field depends so much on the previous condition of the specimen that it does not afford any useful information regarding its condition.

A better method of procedure is to obtain the throw for a reversal of the field, which of course gives $2B$ instead of B , for any value of H . Thus in Fig. 272, if the value of the magnetising field is Oh , and this be reversed to $Oh' = -Oh$, B changes from Ob to Ob' , that is, the ballistic throw is proportional to $bb' = 2Ob$. Instead of halving the value obtained for B to get that corresponding to the magnetising field Oh , it is usual to use a reversal of the current I_1 when obtaining the

standardising throw θ_1 , and since the throw for a reversal is made in both cases, the numerator and denominator in the quantity $\frac{4\pi n_2 n_1 A I_1 \theta}{10 a n_2 \theta_1}$ are both halved, which of course leaves it unaltered, and the fact of reversal may be ignored.

The method of procedure then is to apply the greatest magnetising current that is going to be used, and adjust the resistance R_3 until the ballistic throw on reversing the current by means of the key K (Fig. 271) makes full use of the galvanometer scale, but still lies upon it. This resistance must then remain constant throughout the observations. A few reversals of the current bring the iron into a steady cyclic condition, and then the throw θ for the reversal of the current I from positive to negative and again from negative to positive is observed, and the mean value of the two taken. The current is then reduced by means of the rheostat R_1 , the repeated reversals performed and the process repeated. This is continued down to the smallest currents that give a reasonable throw. The θ 's are then converted into B 's, and the I 's into II 's, and the results plotted in the form of a curve. In Fig. 272 the curve OMP is obtained in this way for a ring of soft iron, and the permeability μ is calculated for each value of H by dividing B by H .

In this method there are no free polar surfaces, the tubes of magnetic induction being complete circuits within the iron; there is therefore no demagnetising effect, which is one of the advantages of this over the magnetometric method. Another advantage is that the galvanometer, if of the suspended coil type, is much less sensitive to outside magnetic disturbances than the magnetometer needle. Thus the employment of the magnetometric method requires the best laboratory conditions for success, but the ballistic method can be carried out almost anywhere. On the other hand, the ballistic method requires the welding, turning to circular form, and separate winding of each specimen examined, whereas in the magnetometric method any piece of the wire to be tested can be immediately placed in the magnetising solenoid for experiment. Then again the ballistic method does not, as a rule, give us the cycle of magnetisation, but only the curve passing through the tips of the cycles for various magnetising fields.

Cycle by Ballistic Method.—If a cyclic curve of magnetisation be required, it may be found by modifying the key K, Fig. 271, by replacing one of the cross conductors ab by a rheostat R_3 (Fig. 273). In making the reversals to establish the steady cycle of magnetisation, the short-circuiting tapping key T can be closed. To make the first measurement, T is kept closed and the rocker which connects e to d and f to b thrown over to a and c , which simply reverses the current. The reversal of H , from the value OE to OF (Fig. 274) causes a throw proportional to the change of induction AB, and this is plotted downwards from A, the point C on the curve being obtained. The

process is now repeated with T open, so that the magnetising field OE is reversed to the value OG, the corresponding throw being proportional to AL. This gives us the point M on the curve. T is then closed, the reversals made to re-establish the cycle, R_3 increased, T opened, and another throw obtained, giving the point

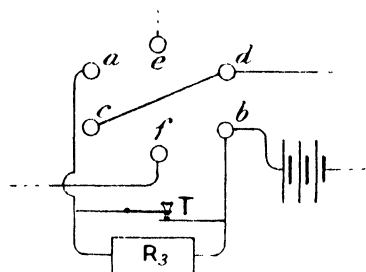

FIG. 273.

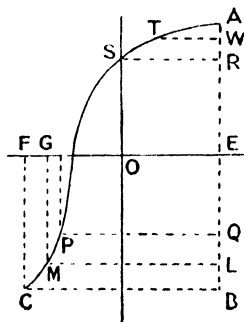

FIG. 274.

P on the curve. The point S is found by merely breaking the circuit to reduce the field to zero, the throw proportional to AR being obtained. Points such as T are obtained by diminishing the field OE or suddenly increasing, by a small amount, the resistance of R_1 (Fig. 271). The other half of the cycle may then be drawn from symmetry.

The values of I may be obtained from those of B by means of the relation $B = H + 4\pi I$. Thus the I—H curve may be derived from the B—H curve, and *vice versa*.

Cycle of Magnetisation—Hysteresis.—The behaviour of magnetic materials when subjected to cyclic changes of magnetic field, were first systematically studied by Prof. J. A. Ewing, and for a detailed study of such cyclic changes, the student is referred to Ewing's work on "Magnetic Induction in Iron and other Metals." A typical cycle is seen in Fig. 275, the behaviour of the material being represented by the curve OABCDEFG. It will be observed that the descending branch of the curve always lies above the ascending branch. Hence the zero value of I occurs at a later point of the cycle than the zero value of H. To this lag of the magnetisation behind the magnetising field Ewing gave the name of *Hysteresis*.

The value OC of the intensity of magnetisation when the magnetising field is reduced from great values down to zero is called the *Residual Magnetism*. The value OP of the reversed field required to reduce the intensity of magnetisation to zero, is called the *Coercive Force*. A knowledge of the intensity of magnetisation near saturation, together

the residual magnetism and coercive force are practically zero. The effect upon steel is in the same direction, but is not so marked.

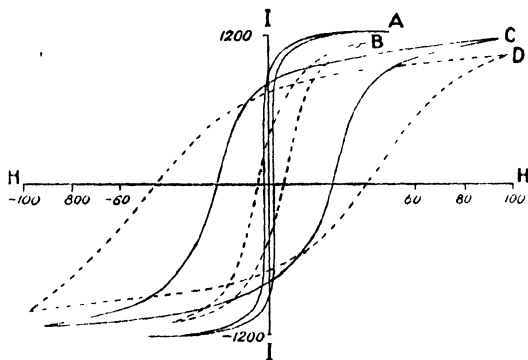

FIG. 276.

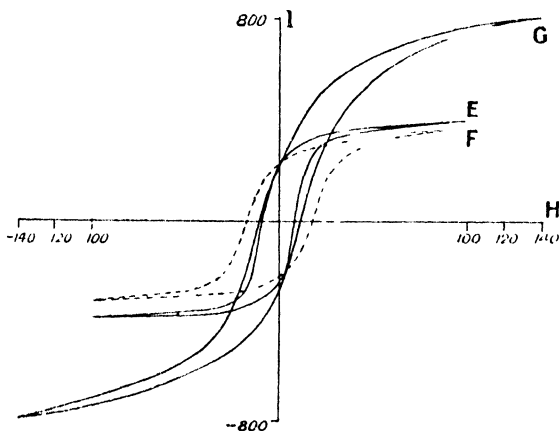

FIG. 277.

Work due to Hysteresis.—The act of taking a body through a cycle of magnetisation involves the expenditure of energy; for the energy required to magnetise a specimen is not recoverable on removing the magnetic field, since the magnetisation does not fall to nothing; a negative field has to be applied before the intensity of magnetisation is brought to zero.

We will show from first principles that the work necessary to produce a change dI in the intensity of magnetisation is HdI , dI being

so small that the magnetising field H may be considered to be constant throughout the change.

Let m be the magnetic moment of one of the molecular magnets of the material, and θ the angle its axis makes with the direction of magnetisation.

$m \cos \theta$ and $m \sin \theta$ are the components of its moment parallel and normal to the direction of magnetisation. Then for the whole of the magnetic molecules throughout unit volume, $\Sigma m \cos \theta = I$, the total magnetic moment per unit volume, and further $\Sigma m \sin \theta = 0$, otherwise there would be a component of the magnetic moment at right angles to the direction of magnetisation, which is contrary to the very meaning of the term

From the former equation we have—

$$\begin{aligned} d\Sigma m \cos \theta &= dI \\ \text{i.e.} \quad -\Sigma m \sin \theta \cdot d\theta &= dI. \end{aligned}$$

Now the couple acting on the molecule m in the field H is $mH \sin \theta$ (Fig. 278); and for a small rotation $-d\theta$ the work done is $-mH \sin \theta \cdot d\theta$.

For all the molecules in unit volume—

$$\begin{aligned} \text{work done} &= -\Sigma mH \sin \theta \cdot d\theta, \\ &= -H\Sigma m \sin \theta \cdot d\theta, \end{aligned}$$

since H is constant. But this means an increase dI in the intensity of magnetisation, and

$$\begin{aligned} -\Sigma m \sin \theta \cdot d\theta &= dI, \\ \therefore \text{work done} &= H dI. \end{aligned}$$

Thus in the I — H diagram, Fig. 279, the work done for the small change dI in the intensity of magnetisation is $H dI$, that is, the area of

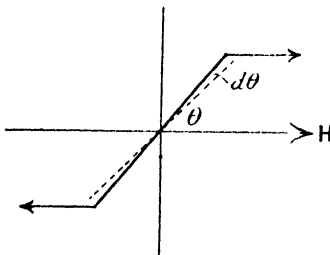

FIG. 278.

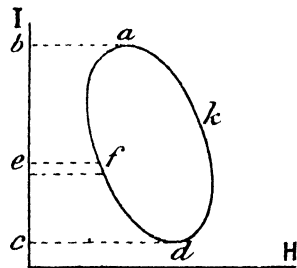

FIG. 279.

the strip ef , and that in passing round the curve from a to d is the area of all such strips, that is the area $abcedfa$. Similarly the work done for the path kda is represented by the area $dkabcd$; and the

balance of work done on the specimen of unit volume, for the whole cycle is area $afdk$; thus $\int_0 H dI$ is the work done for any cyclical path, where \int_0 is the integral round the whole path. We can therefore see that the work for a cycle of magnetisation of steel is much greater than that for soft iron, since the hysteresis curve encloses a much larger area. This work appears in the form of heat in the specimen and represents an irrecoverable loss of energy. Not only is energy lost, but the heating effect is cumulative, and in a mass of iron subjected to an alternating magnetic field, as in the armature core of a dynamo, or the core of a transformer, the consequent rise of temperature may be considerable. For this reason the iron used for these purposes has as low a hysteresis effect as possible.

The area $\int_0 H dI$ may be obtained from any of the I—H cycles, paying due regard to the scale upon which the curve is drawn. If the curve be one for B and H, the area must be divided by 4π to obtain the work done per cubic centimetre per cycle.

$$\begin{aligned} \text{For,} \quad & B = H + 4\pi I, \\ \therefore H dB &= H dH + 4\pi H dI, \\ \text{and,} \quad & \int_0 H dB = \int_0 H dH + 4\pi \int_0 H dI. \end{aligned}$$

The term $\int_0 H dH$ is necessarily zero, for if we plot H against H, we get a straight line, and the area enclosed for any cycle will of course be zero.

The value of $\int_0 H dI$ varies from about 10,000 ergs for annealed soft iron to 117000 ergs for hardened pianoforte steel wire.

Taking the density of iron as 7.7 and its specific heat 0.11, the thermal capacity of 1 c.c. is 7.7×0.11 , and the rise in tem-

perature per cycle of magnetisation is $\frac{\int_0 H dI}{7.7 \times 0.11 \times 4.2 \times 10^7}$ degrees; the mechanical equivalent of one calorie being 4.2×10^7 ergs. For a value of 50,000 for $\int_0 H dI$, and a frequency of 100 cycles per second, we have a rise of temperature per second of—

$$\frac{50000 \times 100}{7.7 \times 0.11 \times 4.2 \times 10^7} = 0.14^\circ,$$

or 8.4° per minute, provided that the heat produced did not leak away.

Hysteresis Tester.¹—The importance of this hysteresis loss of

¹ J. A. Ewing, Inst. Elec. Eng., vol. 24, p. 398. 1895.

energy in a magnetic material led Prof. Ewing to devise a piece of apparatus by means of which the hysteresis loss in a specimen of the material may be found, without making the laborious test for finding the magnetic cycle. The specimen is rapidly rotated between the poles of a permanent magnet, which is supported upon knife edges to enable it to turn about a horizontal axis (Fig. 280).

As the specimen rotates, it is magnetised by the field of the

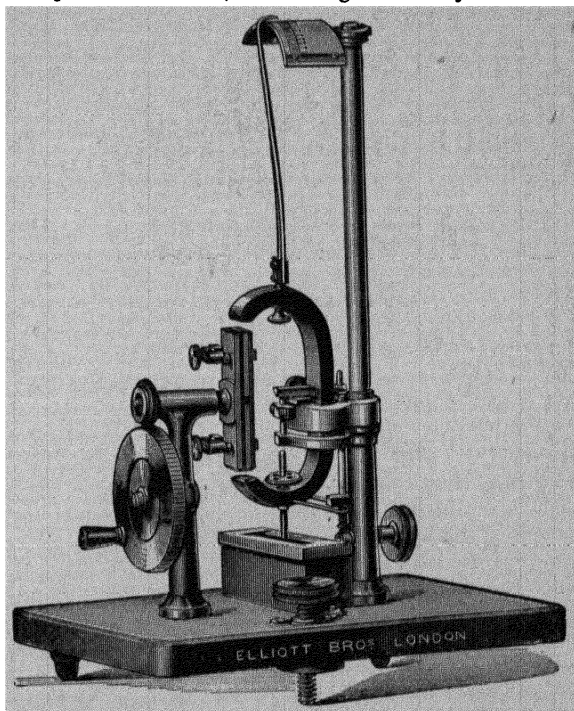

FIG. 280.

permanent magnet, the lag in polarity causing it, by the attraction between the respective poles, to drag the magnet after it. The deflection of the magnet is measured by the pointer and scale, and is proportional to the hysteresis effect in the specimen, being independent of the speed of rotation. This may be shown in the following manner :—

Let H be the field due to the permanent magnet at any point, and θ the angle between H and the direction of magnetisation of the specimen at the point. As the specimen makes one complete rotation,

its magnetisation at the point considered goes through a cycle, and the work done due to hysteresis is $\int_0 H dI$ per unit volume.

Thus, at the point considered, H in this expression must be replaced by $H \cos \theta$, and further, $I = kH \cos \theta$, where k is the susceptibility.

$$\therefore dI = -kH \sin \theta \cdot d\theta.$$

Therefore the work done for one cycle is—

$$\int_0 H \cos \theta (-kH \sin \theta) d\theta = -\int_0 kH^2 \sin \theta \cdot \cos \theta \cdot d\theta.$$

Again, to find the couple exerted on the specimen,— I is the magnetic moment of unit volume, and the couple on it is therefore $HI \sin \theta$, tending to rotate the specimen into the direction of H , and—

$$I = kH \cos \theta, \\ \therefore \text{couple} = kH^2 \sin \theta \cdot \cos \theta.$$

The mean value of this for a complete rotation is—

$$\frac{\int_0 kH^2 \sin \theta \cdot \cos \theta \cdot d\theta}{\int_0 d\theta} = \frac{1}{2\pi} \int_0 kH^2 \sin \theta \cdot \cos \theta \cdot d\theta.$$

Comparing this with the expression for the work done due to hysteresis, we see that the variable parts are identical, and therefore the mean couple acting between the specimen and the permanent magnet is proportional to the hysteresis effect, and is independent of the speed of rotation. It is balanced by the gravitational couple, which is measured by the deflection of the permanent magnet from its mean position.

The instrument is calibrated by means of two specimens, one of low and the other of high hysteresis value, and the samples to be tested are made of the same size and shape as the standards, the length being the important quantity to have correct.

Steinmetz Law.—An empirical formula for the work done in a cycle of magnetisation has been given by Steinmetz,¹ which is very useful for many practical purposes; it states that the work per cycle is proportional to the magnetic induction raised to a constant power which ranges between 1.66 and 1.70.

Thus—
$$\int_0 H dI = \eta B^{1.68},$$

where η is a coefficient depending upon the material, and B the maximum value of the induction during the cycle.

¹ C. P. Steinmetz, *Electrician*, 26, p. 261 (1891); 28, p. 425 (1892).

For very soft iron	$\eta = 0.0020.$
„ hardened steel	$\eta = 0.025.$
„ annealed cast-steel	$\eta = 0.0080.$
„ nickel	$\eta = 0.012 \text{ to } 0.038.$
„ cobalt	$\eta = 0.012.$

The law only roughly represents the truth, and can only be used for approximate purposes.

Iron and Steel Alloys.—Many substances, such as silicon, chromium, tungsten, and manganese, in small quantities, profoundly modify the magnetic properties of steel. Thus chromium, tungsten, or manganese, in small quantities (up to 4 per cent.), greatly increase the coercive force, in some cases up to 40 or even 50, while 12 per cent. of manganese (Hadfield's manganese-steel) renders it almost non-magnetic at low fields, the permeability being about 1.4 for all fields.

Magnetic Alloys of Non-magnetic Substances.—It was found by Heusler¹ that it was possible to produce an alloy of non-magnetic substances that shall itself be magnetic. Thus several alloys of manganese, aluminium, and copper, and of manganese, aluminium, and zinc, exhibit marked magnetic properties. An alloy of 26.5 per cent. Mn, 14.6 Al, and 58.9 Cu, has a permeability of 225 for a magnetising field of strength 20.¹ The magnetic behaviour of these alloys depends very much upon their previous condition with regard to temperature.

Force between Magnets in Contact.—When two magnetic polar faces are in contact, as in the case of a soft iron core divided transversely, there is a force pulling the two polar faces together. Let σ be the amount of pole per unit area of face, N on one side and S on the other. Then each produces a field of strength $2\pi\sigma$, and the other polar face being situated in this, experiences a force $2\pi\sigma^2 = F$ per unit area. The two faces are not in contact at more than a few points, and the strength of field H in the air interspace is $4\pi\sigma = H$ (p. 268).

$$\therefore F = \frac{H^2}{8\pi}.$$

But the magnetic field being normal to the faces, the value of H in the gap is equal to the value of B in the iron (p. 234).

$$\therefore F = \frac{B^2}{8\pi}.$$

Weak Magnetic Fields.—The experiments described above are not sufficiently delicate to determine the form of the curve of magnetisation very near the origin. Lord Rayleigh² has examined this point, and finds that for very weak fields k and μ are constant, and hence the I—H and B—H curves are practically straight lines near the origin, and are inclined to the axis of H. The method he adopted was to place the specimen inside a magnetising coil B (Fig. 281), with its end

¹ Fr. Heusler, "Verh. D. Phys. Ges.," 1903.

² Lord Rayleigh, *Phil. Mag.*, 23, p. 225. 1887.

very close to the magnetometer needle. For moderate field strength the effect on the magnetometer needle is balanced by a coil A, in series with B. On varying the current, the balance is still perfect if

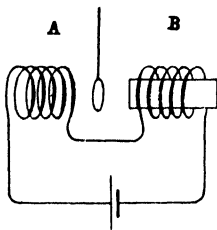

FIG. 281.

the permeability is everywhere constant, but if that of the specimen varies, the effect of A and B on the needle will not change at the same rate, and the balance is destroyed. With a piece of Swedish iron wire the balancing was made with a field of strength 0.04, and it was found to remain perfect as the field was reduced to 0.00004. Hence, for these fields the permeability is constant. Up to values of H equal to 1.2, the following formulæ gave, fairly well, the values of k and μ .

$$k = 6.4 + 5.1H.$$

$$\mu = 81 + 64H.$$

Time Lag.—Prof. Ewing found that in the case of soft iron, the specimen did not take its final value of the magnetisation instantaneously, and in employing the magnetometer, an interval had to be allowed to elapse before reading the deflection, to allow the magnetisation to creep up to its full value. This renders the readings taken by the ballistic method somewhat uncertain, but if the ballistic galvanometer were replaced by the Grassot Fluxmeter (p. 263) this difficulty would be removed. With hard

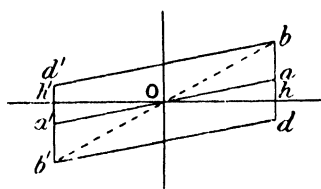

FIG. 282.

for the weak field Oh (Fig. 282) suddenly applied, the resulting intensity of magnetisation is ha , but after a time this creeps up to hb . If the field had been applied very slowly, the path Ob would have been followed. On then suddenly reversing the field bd' is the curve followed, and with time the point b' is slowly reached. Another reversal, followed by a pause, gives the path $b'db$. Thus for a cycle consisting of rapid reversals, the magnetisation curve is $aoa'oa$, and there is no hysteresis loss; for very slow change of field the curve is $bob'ob$, again with no hysteresis; but for any other change there is always a loop

¹ J. A. Ewing, *Proc. Roy. Soc.*, 46, p. 269. 1889.

and consequently hysteresis loss, reaching a maximum for the path $bd'b'db$.

Very Strong Fields.—In order to determine whether the intensity of magnetisation really approaches a limiting saturation value, as indicated by the molecular theory, Prof. Ewing and Mr. Low¹ employed what they called the Isthmus method. The specimen forms a neck or isthmus between the tips of the conical poles of an electromagnet. They showed that for greatest uniformity of field at the neck, the semi-angle of the cone should be $39^{\circ} 14'$ while for greatest value of the field it should be $54^{\circ} 44'$. Both forms were used. The magnetic induction in the specimen forming the neck was measured by winding a coil on it and rotating it through 180° , the throw of a ballistic galvanometer in series with the coil being observed. In order to make the rotation possible, the tips of the pole pieces are bored through transversely by a circular hole $abcd$ (Fig. 283), and an iron bobbin with the neck as shown placed to fill the hole. The strength of magnetising field is determined by winding a second coil outside the first, so that it encloses an air space of known section. The difference in the ballistic throws for the two coils is proportional to the magnetic flux through the air space between the coils, and therefore to the magnetising field.

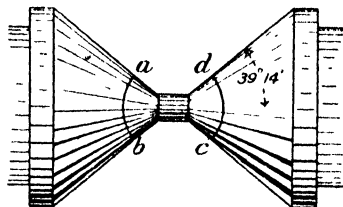

FIG. 283.

The results for a specimen of Vicker's tool steel are given below—

H	B	I	μ
6210	25480	1530	4.10
9970	29650	1570	2.97
12120	31620	1550	2.60
14660	34550	1580	2.36
15530	35820	1610	2.31

It will be seen that the intensity of magnetisation has become very nearly constant, and μ seems to be approaching the value unity, which it should have for infinite fields if I ceases to increase; for we see from the expression—

$$B = H + 4\pi I,$$

that if H becomes very great compared with $4\pi I$, the latter is negligible, and $B = H$, or $\mu = 1$.

¹ J. A. Ewing and W. Low, *Phil. Trans.*, A., 180 (i), p. 221. 1889.

Variation of Temperature.—All magnetic materials vary in susceptibility when the temperature changes. Hopkinson¹ found that in general the susceptibility increases with rising temperature when the specimen is subjected to a weak magnetising field, but for strong fields the reverse is the case. At a dull red heat, iron loses its magnetic properties entirely, the temperature at which this occurs varying from 690° C. to 870° C. for different materials. The change does not take place suddenly, but in a few degrees' rise in temperature the iron changes from a highly magnetic to a non-

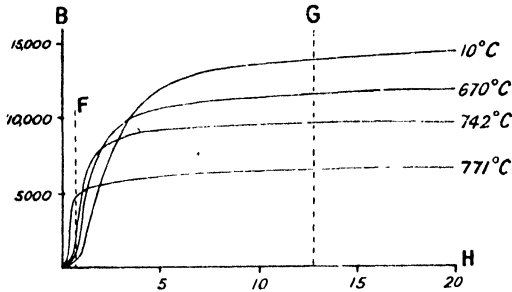

FIG. 284.

magnetic substance. This critical temperature is also the temperature at which recalcence or the sudden reglowing of a mass of cooling iron occurs, and it was shown by Tait that the thermo-electric power of the magnetic metals undergoes rapid changes at the critical temperature. Evidently some important molecular rearrangement occurs at this temperature, and that this arrangement is intimately associated with the acquirement of magnetic properties on cooling, is shown by the fact that non-magnetisable manganese steel (12 per cent. Mn, 1 per cent. C) does not exhibit the phenomenon of recalcence. From Fig. 284, taken from Hopkinson's results, it is seen that in the case of soft wrought-iron, for fields below 0.5 the susceptibility increases with temperature, while for strong fields the susceptibility falls with rising temperature, as will be seen on comparing the changes of B with temperature along the vertical lines F and G. At a temperature of 788° the material has become non-magnetic.

If the permeability be plotted against the temperature for three fields 0.3, 4, and 45, the diagram, Fig. 285, is obtained. It will be seen that for low magnetising fields the permeability increases rapidly as the critical temperature is reached, but for high fields in which the value of B is of course much nearer saturation value throughout, the permeability is not so much affected by temperature, and in all cases the permeability becomes zero at 785° C.

¹ J. Hopkinson, *Phil. Trans., A*, 180 (i), p. 443. 1889.

For nickel, Hopkinson¹ found the critical temperature to be 310° C. and the general course of the phenomenon similar to that in iron.

Ewing has shown² that there is no temperature hysteresis unless the range of variation of temperature includes the critical temperature. That is, on heating and cooling the metal in a magnetic field the intensity of magnetisation at any temperature is the same when the temperature is falling as when it is rising.

It has been found by Curie³ that besides the great change that takes place at the critical temperature, there are others at still

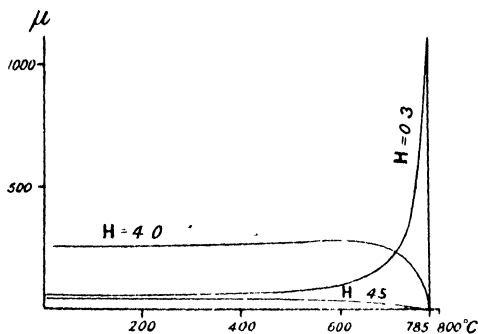

FIG. 285.

higher temperatures, the most important of which consists in a sudden rise in magnetisation at 1280° C. On plotting the magnetisation-temperature curve to a very large scale, it is seen that between 750° and 800° C. the intensity of magnetisation drops to one-hundredth of its value, and then continues to decrease, with a slight inflection at 860° C. At 1280° C. I suddenly rises from about 0.025 to 0.040, and from then again decreases.

Mechanical Stress.—The effects of mechanical stress upon the magnetic properties of materials are exceedingly complicated, but the following are the most striking.

It was found by Villari⁴ that for weak fields, longitudinal tension increases the magnetisation, but for strong fields the reverse is the case. Thus the curves for annealed soft iron wire subjected to a pull are as shown in Fig. 286, after Ewing.⁵ Also the effect of varying the load in a cyclic manner, when the field is constant, is similar in character at all fields, but varies in amount with the field. With a magnetising field of 0.34 the effect of increasing and then decreasing the load is

¹ J. Hopkinson, *Proc. Roy. Soc.*, 44, p. 317. 1888.

² J. A. Ewing, *Phil. Trans.*, 176, p. 523. 1885.

³ P. Curie, *Comptes Rendus*, 118, 726, 859, 1134.

⁴ E. Villari, *Pogg. Ann.*, p. 322. 1868.

⁵ J. A. Ewing, *loc. cit.*

seen in the lower dotted curve (Fig. 287), and on again increasing and decreasing the load, the curve becomes cyclic, as shown by the

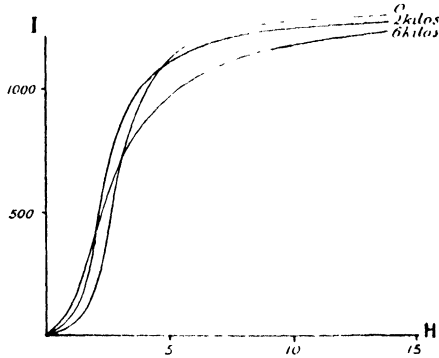

FIG. 286.

full line With a magnetising field of 2.49 the effects are similar and are much more marked. Fewer reversals are necessary to reach the cyclic state at high magnetising fields than at low fields. In

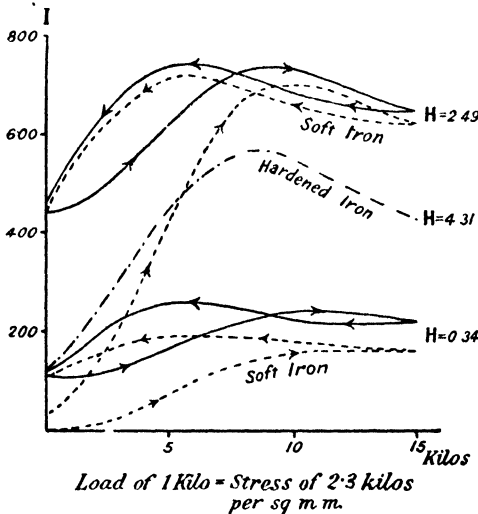

FIG. 287.

the case of steel and hard iron there is no hysteresis, the chain curve in the figure being typical of the changes which take place.

In nickel the Villari reversal is absent, the effect of longitudinal pull being to decrease the magnetisation for all field strengths, while, on the other hand, the effect of longitudinal compression is to increase the magnetisation.¹

The effect of longitudinal tension upon the magnetisation of iron was also investigated by Lord Kelvin,² who found that a transverse stress had the opposite effect to one applied longitudinally. From this, many interesting and complicated effects may be expected when a magnetised wire is subjected to torsion, which effects have been experimentally obtained.

Magneto-striction.—The changes in dimensions caused by magnetisation have been studied by Shelford Bidwell,³ who observed the increase in length by a system of two levers and a mirror, so that by means of the deflection of a spot of light, he could measure a variation of one ten-millionth of the length of the specimen. The variations in length for iron, nickel, and cobalt are given in Fig. 288, which is taken from Bidwell's results. The

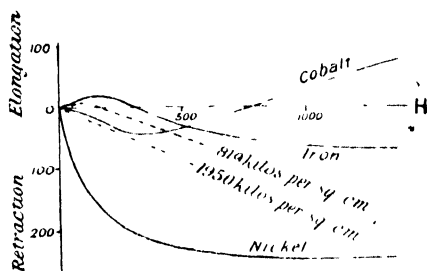

FIG. 288.

effect of applying a tensile stress to the iron at the time of magnetisation is shown in the dotted curves, where the ordinates indicate the elongation due to magnetisation while under stress. The curve changes continuously in character from that under no stress, to that under a stress of 1950 kilos. per square centimetre.

Molecular Theory.—The molecular theory of magnetisation, due in its original form to Weber, has been improved and confirmed by subsequent experimenters, until now it is used universally for explaining magnetic phenomena. The essential truth of it rests upon a few simple facts, namely, the production of new poles when a permanent magnet is broken transversely, and the saturation which occurs in very strong magnetic fields. Again, there is never an excess of one kind of pole over the other in any magnetised body, which may be proved by showing that there is no resultant force producing translation acting upon a magnet in a uniform field. If a magnet be floated upon a cork on water it is seen that the magnet rotates into the meridian but does not move bodily in one direction or the other, as it would if the amount of N pole on it were not equal to the amount of S pole.

¹ J. A. Ewing, *Phil. Trans., A.*, 179 (i), pp. 325 and 333. 1888.

² Sir W. Thomson, *Proc. Roy. Soc.*, 27, p. 439. 1878.

³ Shelford Bidwell, *Proc. Roy. Soc.*, pp. 109, 257 (1886); *Phil. Trans.*, p. 469 (1890); 179 (i), p. 205 (1888).

These effects follow at once if we consider a magnetic body to be a collection of molecular magnets, which in the neutral or unmagnetised state of the body are oriented indiscriminately in all directions, but, in a magnetic field, are rotated into its direction to an extent which increases with the field.

In order to get over the difficulty that all the molecular magnets should not, even in the weakest field, rotate entirely into the direction of the field, and thus at once produce the condition of saturation, Weber assumed that the molecules are subject to restoring couples acting towards their neutral position and of an amount proportional to the displacement. This, however, does not account for the phenomenon of residual magnetisation, and Maxwell suggested that the restoring couples resemble the strain in a solid substance; for small effects the elasticity is perfect and there is no hysteresis, but for strains beyond the elastic limit, the recovery is not perfect and hysteresis is exhibited. Wiedemann suggested that the opposition to rotation is of frictional character, which explanation accounts for the phenomenon of hysteresis, but it would follow that the magnetisation for very weak fields would be zero when the directive force due to the field is less than that required to overcome the frictional resistance to turning. Lord Rayleigh, however, showed that the susceptibility is not zero but has a constant value differing from zero, for extremely weak fields (p. 283).

Prof. J. A. Ewing suggested that the only restraint on the molecules of which a magnetic substance is composed, is due to the magnetic forces occurring between neighbouring molecules, and he showed how

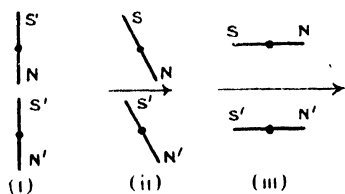

FIG. 289.

the phenomena of residual magnetism, hysteresis, and the other effects in varying field could in this way be accounted for. The student is referred to Ewing's book on "Magnetic Induction in Iron and other Metals," for a full account of this theory, but a general idea of it may be obtained from a few simple considerations.

Consider two neighbouring molecules (Fig. 289). With no external magnetising field they would, if free to turn, set themselves in line (i). In a weak field H , they would be slightly deflected into the direction of the field (ii), but the force between N and S' would prevent their swinging round into the direction of the field. As the field is increased, an unstable state would be reached, when the couples due to the field are greater than the restoring couples due to the poles, and the condition (iii) will be attained.

For a group of four molecules, Fig. 290 (i) represents the condition in zero field, (ii) is the arrangement just before instability is reached, and (iii) the state just beyond instability. Any further increase in the field can only produce a further slight increase into alignment with the

field. A curve of magnetisation corresponding to this group of four molecules is indicated in Fig. 291, and it will be seen to have some resemblance to the actual curves of magnetisation for iron (Fig. 284). When it is remembered that a piece of magnetic material consists of an infinite number of groups of all degrees of stability, it will be seen that the groups will not all break up at the same time, and the angular curve of Fig. 291 will become the flowing curve of magnetisation of Figs. 272 or 284.

By means of a model consisting of a number of pivoted magnets,

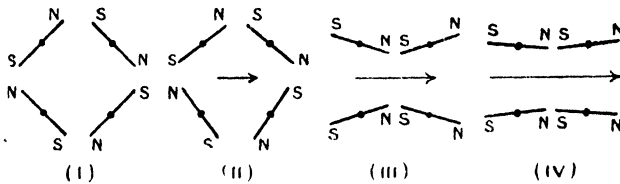

FIG. 290.

the whole cycle of magnetisation may be traced, as the magnetic field undergoes a slow cycle.

The effects of stress, of temperature, and of mechanical vibration are all shown to be consistent with the above theory.

An interesting result, predicted from Ewing's theory, which was afterwards verified by experiment by Prof. Baily¹ is that in a strong field, when all the molecular magnets are nearly in alignment with the field, if the field be caused to rotate, instead of being reversed with constant direction, the molecules will all turn with the field, and the work done in a rotation should be zero. As there is no return to unstable grouping with subsequent remagnetisation in the opposite direction, the phenomenon of hysteresis will therefore be absent. It was found that for rotating instead of alternating field, the hysteresis loss diminished after the strength of the field was increased beyond a certain amount.

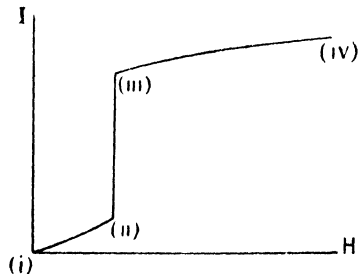

FIG. 291.

The **Magnetic Circuit**.—We have seen that magnetic flux is distributed circuitally, for at the surface of separation of two media the normal magnetic induction is continuous as it crosses the surface (p. 234), and in a uniform medium the tubes of induction are continuous. Consider a tube of induction whose cross-section at any point is s , the value

¹ F. G. Baily, *Phil. Trans., A.*, 187, p. 715. 1896.

of the induction at the section being B . The total normal induction or magnetic flux over this cross-section is Bs , if B is uniform; and if B is not uniform then $\int Bds$ is the flux. This quantity is constant for every section (p. 234) and is therefore characteristic of the tube.

Let us now find the line integral of the magnetic field for a circuital path round the tube of induction. It may be expressed in the form $\int_0 H dl$, if H is everywhere parallel to the element of the path dl , which will be true if the tube is sufficiently narrow; but in any case $\int_0 H \cos \epsilon dl$ will be the line integral, where ϵ is the angle between the directions of H and dl . This line integral is the work done on carrying a unit pole once round the path, and by analogy with the corresponding electrical case, it is sometimes called the Magneto-Motive Force (M.M.F.) round the complete circuit formed by the tube of induction.

We have seen that the line integral of the electric field round any closed path is equal to 4π times the total current linked with the path.

$$\therefore \int_0 H dl = \frac{4\pi n I}{10},$$

where I is the current in amperes flowing in a wire linked with the magnet circuit, and n the number of times the two circuits are linked together. The product nI is frequently called the number of ampere-turns linked with the circuit, and hence we may now write for any magnetic circuit—

$$\text{M.M.F.} = \frac{4\pi}{10} \times (\text{ampere-turns}).$$

Again, for the circuital tube of induction—

$$\text{magnetic flux } N = Bs = \mu Hs$$

$$\therefore H = \frac{N}{\mu s},$$

$$\text{and, } \text{M M F.} = \int_0 H dl = \int_0 \frac{N dl}{\mu s} = N \int_0 \frac{dl}{\mu s}$$

since N is constant for the circuit.

$$\therefore N = \frac{\text{M.M.F.}}{\int_0 \frac{dl}{\mu s}}$$

By analogy with the case of an electric current circuit for which—

$$i = \frac{\text{E M.F.}}{\int \frac{S dl}{s}}$$

where $\int \frac{Sdl}{s}$ is the resistance, S being the resistivity at any point, the quantity $\int \frac{dl}{\mu s}$ is frequently called the *magnetic resistance* of the circuit.

It must be remembered, however, that the resemblance is only in the form of the expressions, as there is no such thing as a magnetic current. The quantity N , although called a magnetic flux is only a statical condition defined by the relation $N = \int \mu H ds$.

When the shape of the tube of induction is completely known, and also the value of μ at each point, the quantity $\int \frac{dl}{\mu s}$ can be found. In

certain simple cases the circuit may consist of several parts, for each of which μ and s are constant, and when this is so, the magnetic resistance of the whole circuit is the sum of the magnetic resistances of these separate parts. In many other cases, where the boundary of the circuit considered is not everywhere parallel to the direction of the flux, useful approximate values for the magnetic resistance may be obtained by following a similar method, but in this case the magnetic circuit is not perfect, and uncertainty in calculation is introduced by the uncertainty of the dimensions of the nearest perfect circuit.

The following examples will illustrate the method :

(i) *Ring wound with Endless Solenoid.*—In this case the magnetic circuit consists of one homogeneous iron ring; B , H , and μ being approximately constant for all points. The magnetic resistance of the

ring is $\int \frac{dl}{\mu s} = \frac{2\pi r}{\mu s}$.

Hence if there are n turns per centimetre length of ring, total turns = $2\pi rn$. With current I amperes in each turn—

ampere turns = $2\pi rnI$,

and M.M.F. = $\frac{4\pi(2\pi rnI)}{10}$;

$$\therefore N = \frac{4\pi(2\pi rnI)}{10} = \frac{4\pi nI\mu s}{\frac{2\pi r}{\mu s}}$$

But,

$$B = \frac{N}{s} = \frac{4\pi nI\mu}{10},$$

and,

$$H = \frac{B}{\mu} = \frac{4\pi nI}{10},$$

a result which we obtained previously on p. 232.

(ii) *Ring with Small Air-Gap*.—If the air-gap have thickness d (Fig. 292), the magnetic circuit consists of two parts $(2\pi r - d)$ cms. of iron, having magnetic resistance $\frac{2\pi r - d}{\mu s}$, and d cms. of air, having magnetic resistance $\frac{d}{s}$, since $\mu = 1$.

$$\begin{aligned} \therefore \text{whole magnetic resistance} &= \frac{2\pi r - d}{\mu s} + \frac{d}{s} \\ &= \frac{2\pi r + (\mu - 1)d}{\mu s}. \end{aligned}$$

Then,

$$N = \frac{4\pi(2\pi r n I)}{10} \cdot \frac{\mu s}{\{2\pi r + (\mu - 1)d\}}.$$

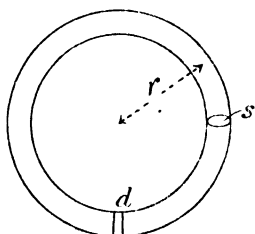

FIG. 292.

By comparison with the value of N for the ring without gap, it will be seen that the magnetic effect of the gap is to increase apparently the length of iron in the ring by an amount $(\mu - 1)d$, which is approximately $1000d$, when $\mu = 1000$. Hence the enormous drop in magnetisation due to quite a small gap.

$$\text{As before, } B = \frac{N}{s} = \frac{4\pi(2\pi r n I)\mu}{10\{2\pi r + (\mu - 1)d\}},$$

and the actual value of H within the iron, where the permeability is μ , is—

$$H = \frac{B}{\mu} = \frac{4\pi(2\pi r n I)}{10\{2\pi r + (\mu - 1)d\}}.$$

Calling the corresponding value of the magnetising field when there is no gap, H' —

$$H' = \frac{4\pi(2\pi r n I)}{10(2\pi r)},$$

and we have—

$$\frac{H'}{H} = \frac{2\pi r + (\mu - 1)d}{2\pi r} = 1 + \frac{(\mu - 1)}{2\pi} \cdot \frac{d}{r}.$$

But $\frac{d}{r} = \theta$, the angular thickness of the gap ;

$$\therefore H' = H + \frac{(\mu - 1)}{2\pi} H \theta.$$

Now,
and,

$$\begin{aligned} \mu &= 1 + 4\pi k, & \therefore \mu - 1 &= 4\pi k, \\ kH &= I, \\ \therefore H' &= H + 2I\theta \\ &= H + \frac{4\pi\theta^{\circ}}{360} I \end{aligned}$$

where θ° is given in degrees instead of radians, for—

$$\theta^{\circ} = \frac{360}{2\pi} \theta.$$

The equation is therefore $H = H' - \frac{4\pi\theta^{\circ}}{360} I$, and it will be seen by comparison with the equation on p. 269, that the gap produces a demagnetising effect, the coefficient of demagnetisation being $\frac{4\pi\theta^{\circ}}{360}$. When the gap has a thickness of half a degree—

$$H = H' - 0.0174I.$$

And it will be seen from the table on p. 270, that the demagnetising effect of the gap is nearly the same as that for an ellipsoid whose length is fifty times its diameter.

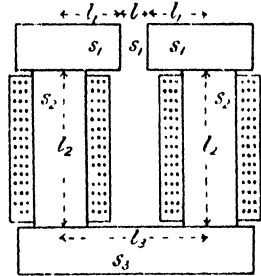

FIG. 293.

(iii) Core of Electro-magnet.—In a complicated case such as the core of an electro-magnet (Fig. 293), an approximate value of the magnetic resistance may be obtained from the dimensions of the circuit. Thus—

for the air gap, magnetic resistance	=	$\frac{l}{s_1}$,
for the pole pieces	"	= $\frac{2l_1}{\mu_1 s_1}$,
for the cores	"	= $\frac{2l_2}{\mu_2 s_2}$,
and for the yoke	"	= $\frac{l_3}{\mu_3 s_3}$.

The total magnetic resistance is then—

$$\frac{l}{s_1} + \frac{2l_1}{\mu_1 s_1} + \frac{2l_2}{\mu_2 s_2} + \frac{l_3}{\mu_3 s_3},$$

and if there are nI ampere turns—

$$\frac{4\pi nI}{10} = N \left(\frac{l}{s_1} + \frac{2l_1}{\mu_1 s_1} + \frac{2l_2}{\mu_2 s_2} + \frac{l_3}{\mu_3 s_3} \right)$$

The value of B in the air-gap is N/s_1 , and since the permeability is here unity, this is also the strength of field in the gap. The above calculation is only an approximation, since the circuit is very imperfect from the magnetic point of view, but it becomes more reliable as the air-gap is reduced, since the magnetic induction in that case will be more confined to the iron, less straying into the surrounding space.

Bar and Yoke Tests.—The objections to the magnetometer and the ring methods of measurement of permeability, consist in the necessity

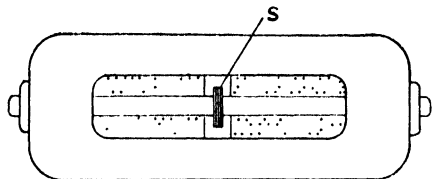

FIG. 294.

for drawing the material into the form of a wire in the former case and welding it into a ring in the latter. Both processes produce physical change in the material, and hence the desirability of employing some method in which these processes are unnecessary. Hopkinson¹ used a straight bar of the material and completed the magnetic circuit by means of a heavy soft-iron yoke, so that there are no free poles (Fig. 294). The magnetising coil is wound on the rod, the number of ampere-turns being known. In the earlier experiments, the experimental rod was constructed in two parts so that the secondary coil S , which is in series with the ballistic galvanometer, might be jerked out of the field on separating the parts of the rod. The joint, where the ends of the rod are in contact, introduces an unknown magnetic resistance, so in later experiments the rod was made in one piece and the ballistic throw for a reversal of the magnetising current observed.

Then, if l_1 , s_1 , and μ_1 are the length, area, and permeability of the rod, and l_2 , s_2 , and μ_2 the values for the yoke—

$$\text{magnetic resistance of circuit} = \frac{l_1}{\mu_1 s_1} + \frac{l_2}{\mu_2 s_2},$$

and,

$$\frac{4\pi nI}{10} = N \left(\frac{l_1}{\mu_1 s_1} + \frac{l_2}{\mu_2 s_2} \right),$$

where nI is the number of ampere-turns in the magnetising coil.

Then if H is the magnetising field, and B the induction in the rod—

$$N = Bs = \mu_1 H s_1;$$

$$\therefore H = \frac{4\pi nI}{10 \left(l_1 + \frac{l_2 s_1 \mu_1}{\mu_2 s_2} \right)}.$$

¹ J. Hopkinson, *Phil. Trans.*, 176, p. 455. 1885.

If the rod alone formed a complete magnetic circuit so that there were no free poles, as in the case of the ring, we should have had—

$$H = \frac{4\pi nI}{10l_1},$$

and we see that the yoke is equivalent to an additional length $\frac{l_2\mu_2}{\mu_1 s_2}$ of rod. This is made as small as possible by making s_2 and μ_2 large, the yoke being of high permeability soft iron, and as massive as possible.

Double Bar and Yoke.—The method has been modified by Prof. Ewing¹ by using a double bar and yoke in such a way that the error due to the yoke is eliminated.

The equation for H on the last page, may be written—

$$H = \frac{4\pi nI}{10l_1} - \frac{l_2 s_1 \mu_1 H}{s_2 \mu_2 l_1}.$$

But $\mu_1 H = B$, the induction in the rod ;

$$\therefore H = \frac{4\pi nI}{10l_1} - B \left(\frac{l_2 s_1}{s_2 \mu_2} \right) \frac{1}{l_1}.$$

Two rods RR are employed, which are united at their ends by two

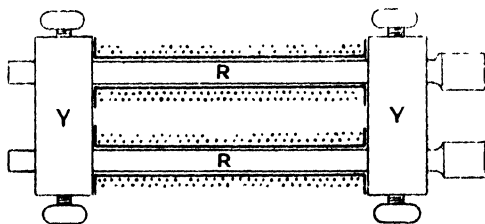

FIG. 295.

massive soft-iron yokes YY (Fig. 295). Then, for any given value of B, the quantity $B \left(\frac{l_2 s_1}{s_2 \mu_2} \right)$ is constant for the given yokes, and writing ϵ in place of it, we have, taking l as the length of the rod—

$$H = \frac{4\pi nI}{10l} - \frac{\epsilon}{l}.$$

Now $\frac{4\pi nI}{10l}$ is the magnetising field H' due to the coil when there is

¹ Ewing, "Magnetic Induction in Iron and other Metals."

no correction to be applied on account of the magnetic resistance of the yokes.

$$\therefore H = H' - \frac{\epsilon}{l}$$

With half the length of rod, the equation would have been—

$$H = H'' - \frac{2\epsilon}{l}$$

$$\begin{aligned} \therefore H'' - H &= \frac{\epsilon}{l} \\ &= H' - H. \end{aligned}$$

The measurement of the induction B is therefore made twice over, the length of rod in the second case being half the length in the first,

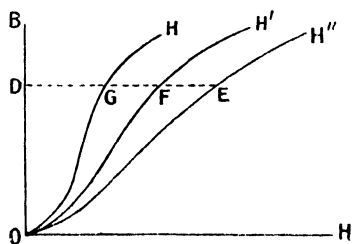

FIG. 296.

with the same number of turns per centimetre of the magnetising coil in the two cases. This is attained by having the magnetising coils wound on two pairs of bobbins, one twice the length of the other, the first having 100 turns on 12.56, *i.e.* 4π cms., and the other 50 turns on 6.28, *i.e.* 2π cms.,

so that in each case $\frac{4\pi n I}{10l} = 10 \times I$.

A curve of B and H for each arrangement is obtained by the ballistic method in the ordinary way, and the curves for H' and H'' plotted as in Fig. 296. Then for each value of B , such as OD , we have seen that—

$$H'' - H' = H' - H.$$

Hence if FG be made equal to EF , *i.e.* to $H'' - H'$, the point G is situated on the true or corrected B — H curve.

The two bars must be of the same material, and the B — H curve being found, one of the bars may be compared with a bar of any other material, having the same dimensions, by the rapid method to be next described. The experiment with the double bar and yoke is carried out in a similar manner to that with the ring (p. 274), a set of observations being made with each pair of magnetising coils. The secondaries of these and of the standardising coil are permanently in series, so that the resistance of the secondary circuit is not changed during the experiment.

Permeability Bridge.¹—The rod A, standardised by the double bar and yoke method, and B the rod to be tested, are placed between massive yokes CD as in the double bar and yoke test, the direction of magnetisation produced by the magnetising coils being shown by arrows in the plan in Fig. 297. The distance between the yokes is 12.56 cms., and the number of turns upon A, 100, so that the magnetising field in A is $10 \times I$. The number of turns upon B can be varied by means of a switch or plugs, until the induction is the same in the two rods, the ratio of the number of magnetising turns upon A and B when this balance is obtained being the ratio of the two magnetising fields required to produce that particular value of B in the two rods. If M (Fig. 298) is a point on the B—H curve found by the last experiment (p. 297) for the rod A, and the ratio LN : LM be that of the magnetising fields in B and A for this value of the induction, the point N on the B—H curve for the specimen is found. The whole curve ONH₁ may be found from the standard curve OMH in the same manner by taking the ratio of the magnetising turns for various values of the induction B.

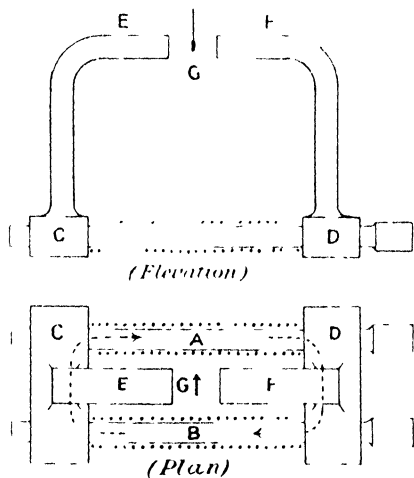

FIG. 297.

The test for equality of the values of B in the two rods is made by observing that the suspended magnet G (Fig. 297) remains stationary when the magnetising current, which passes through the two magnetising coils in series, is reversed. This shows that there is no magnetic flux passing from C to D through the soft-iron horns E and F. Hence the flux entering the yoke C from the specimen B is equal to that leaving C by the specimen A, and the same for the yoke D, and the magnetic induction in A is therefore equal to that in B.

Permeameter.—For testing the magnetic properties of iron in bulk without the necessity of making specimens of it into a wire or rod, C. V. Drysdale² has devised the instrument which he calls the permeameter. By means of a specially designed drill, a hole is bored into the material, leaving a central pin A (Fig. 299). Into the hole is

¹ J. A. Ewing, *The Electrician*, 37, p. 41. 1896.

² C. V. Drysdale, *Journ. Inst. Elec. Eng.*, 31, p. 283. 1902.

inserted an iron plug *E* carrying a bobbin upon which the magnetising and the secondary coils are wound, the bobbin fitting on to the pin *A*. It will be seen from the diagram that the magnetic circuit lies within the material to be tested, except at the small portion of its path where

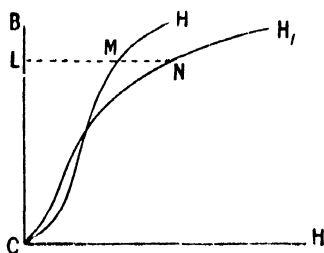

FIG. 298.

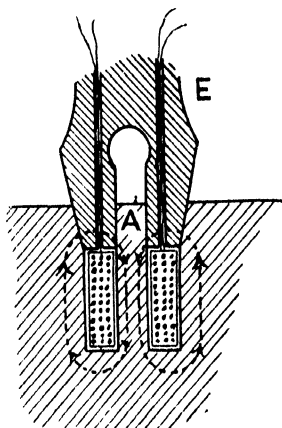

FIG. 299.

it passes through the iron plug *E*. The author describes several methods of making the tests, but the most satisfactory is to obtain the *B—H* curve as described on pages 274 and 275.

CHAPTER XI

VARYING CURRENTS

THE laws which govern the flow of steady currents in conductors are inadequate to determine the value of the current when changing. From Ohm's law we can define the resistance of a conductor to steady current, and then calculate the electromotive force required to produce any current in the conductor. When, however, the current varies, the magnetic flux linked with the circuit varies, and we have seen that this variation in the magnetic flux linked with the circuit means another electromotive force acting in it. Again, there may be accumulation of electric charge at some part in the circuit, and this also implies a changing electromotive force in the circuit. For simplicity, we shall in the first place neglect this last effect, which is only of importance within certain limiting values of the capacity in the circuit, and confine our attention to the effect of the changing magnetic flux. The effect of capacity will afterwards be treated, and finally the circuit will be dealt with, in which the effects are all taken into account.

Inductance.—When the magnetic flux linked with a circuit is changing, an electromotive force acts round the circuit, whose value is the rate of change of the flux (p. 249). Thus—

$$e = - \frac{dN}{dt}.$$

Again, for current i in the circuit there is always a magnetic flux linked with the circuit; let this flux be li . Then—

$$N = li \dots \dots \dots (i)$$

and,
$$e = - \frac{d(li)}{dt} = - l \cdot \frac{di}{dt} \dots \dots \dots (ii)$$

provided that l is constant, which is true so long as there is no material of variable permeability in the neighbourhood of the circuit.

When the current i is increasing, we may, by the laws on page 248 and 249, show that the induced electromotive force e is in the opposite direction to the current; consequently work is being performed

at the rate ei ergs per second, the energy appearing somewhere in the circuit (p. 60). That is—

$$\begin{aligned} \text{rate of working} &= ei \\ &= -li \cdot \frac{di}{dt} \text{ ergs per second} \end{aligned}$$

and for the total work done in opposing this E.M.F. while the current i_0 is being established—

$$-\int_0^{i_0} li \frac{di}{dt} dt = -l \int_0^{i_0} idi = -\frac{1}{2} li_0^2 \quad . . . \text{ (iii)}$$

i_0 being the final steady value of the current.

The quantity l which appears in these three equations is called the Coefficient of Self-Induction or the Self-Inductance of the circuit; it may be defined from (i) as the flux linked with the circuit when unit current flows in it; from (ii) as the E.M.F. round the circuit due to unit rate of change of current in it; and from (iii) as twice the work done in establishing the magnetic flux associated with unit current in the circuit.

The three values of l are constant, and are, moreover, identical so long as the medium comprising the magnetic circuit linked with the current has constant magnetic permeability, but when μ is variable the three values are neither identical nor constant, and the inductance of the circuit may be defined from either of the equations, the question of the most convenient definition for any particular problem, being decided by experience. Thus, if OEA (Fig. 300) be the curve connecting

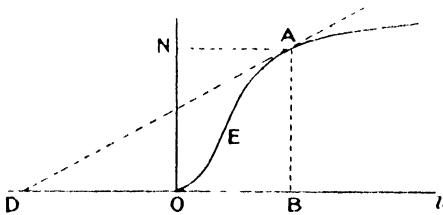

FIG. 300.

N the total magnetic flux and the current i in the circuit considered, it is of the same form as the B—H curve, the scale only being changed; for $N = Bs$, when B is constant across any section of the magnetic circuit, or $\int Bds$ in any case; and the magnetising field is everywhere proportional to the current. Then from equation (i)—

$$l = \frac{N}{i} = \frac{AB}{OB}.$$

Again,

$$e = -\frac{dN}{di} \cdot \frac{di}{dt},$$

and $\frac{dN}{di}$ is equal to $\frac{AB}{DB}$, where AD is the tangent to the curve at the point A; hence—

$$e = -\frac{AB}{DB} \cdot \frac{di}{dt}.$$

But from equation (ii)—

$$e = -l \frac{di}{dt},$$

$$\therefore l = \frac{AB}{DB}$$

The work done in establishing the current is—

$$\int_0^t e i dt = - \int_0^t i \frac{dN}{dt} dt = - \int_0^N i dN$$

$$= \text{area OEANO.}$$

But from equation (iii)—

$$\text{work} = -\frac{1}{2} l \cdot OB^2,$$

$$\therefore \frac{1}{2} l \cdot OB^2 = \text{area OEANO.}$$

$$\therefore l = \frac{2 \text{ area OEANO}}{OB^2}.$$

It will easily be seen that if OEA becomes a straight line, in which case the permeability is constant, all these quantities are equal and are moreover constant.¹

In practice the meaning of the term self-inductance must vary with the conditions in which it is employed; with iron in the circuit it varies from value to value of the current, but without iron the term has a definite meaning, and for a given conducting circuit it is constant so long as the current does not change so rapidly that the distribution of current in the conductor itself differs from that for a steady current.

Growth of Current.—While the current in a circuit is growing, the electromotive force $-l \frac{di}{dt}$ is acting, and therefore the resultant electromotive force overcoming the resistance of the circuit is $e - l \frac{di}{dt}$, where e is the applied electromotive force due to outside sources. Hence our equation from which to obtain the current, changes from $e = ri$ for steady current, to $e - l \frac{di}{dt} = ri$ for varying current,

$$\therefore l \frac{di}{dt} + ri = e.$$

This is the general equation of electromotive forces for a circuit having inductance and resistance only. In order to integrate it let it be written in the form—

$$\frac{di}{e - ri} = dt,$$

¹ W. E. Sumpner, *Phil. Mag.* (Ser. 5), 25, p. 453. 1888.

or, assuming l to be constant—

$$-\frac{l}{r} \cdot \frac{d\left(\frac{e - ri}{l}\right)}{\frac{e - ri}{l}} = dt.$$

Integrating both sides, we have—

$$\frac{l}{r} \log_e \left(\frac{e - ri}{l} \right) = -t + k.$$

k is the constant of integration, to be determined from the conditions of the problem; for the differential equation represents the manner in which the quantities vary with respect to each other, and its integral is the total change in a given time, but will not give us the value of the current reached at the end of this time, unless we know the value at the beginning of the time during which the change has taken place. Let the current at the moment of applying the external E.M.F. be zero, *i.e.* let $i = 0$ when $t = 0$. Then—

$$\frac{l}{r} \log_e \cdot \frac{e}{l} = k,$$

and substituting this value for k we have—

$$\frac{l}{r} \log_e \left(\frac{e - ri}{l} \right) - \frac{l}{r} \log_e \frac{e}{l} = -t$$

or,
$$\log_e \frac{e - ri}{e} = -\frac{r}{l} t.$$

Writing this in its exponential form we have—

$$\frac{e - ri}{e} = \epsilon^{-\frac{r}{l} t}$$

$$\text{or, } i = \frac{e}{r} (1 - \epsilon^{-\frac{r}{l} t})$$

$\frac{e}{r}$ is the final steady value of the current, and writing i_0 for this we have—

$$i = i_0 (1 - \epsilon^{-\frac{r}{l} t}),$$

an equation which shows us how the current grows. The mode of growth is shown in Fig. 301, in which the values of i and t are plotted. Strictly speaking the current never reaches its steady value i_0 but continually approaches it.

Thus for i to equal i_0 —

$$\epsilon^{-\frac{r}{l} t} = 0,$$

$$\therefore t = \infty.$$

The rate of growth of the current may easily be found; it is—

$$\frac{di}{dt} = \frac{r}{l} i_0 \epsilon^{-\frac{r}{l} t} = \frac{r}{l} (i_0 - i).$$

This gets less as i approaches its final value i_0 , but for any value of i it is proportional to $\frac{r}{l}$. The rate at which a current approaches its final value therefore depends upon the ratio $\frac{r}{l}$ and not upon the separate values of r and l . Unless the circuit has a great many turns, or the circuit includes iron, l is usually very small compared with r , so that the current approximates to its final value in a very small fraction of a second.

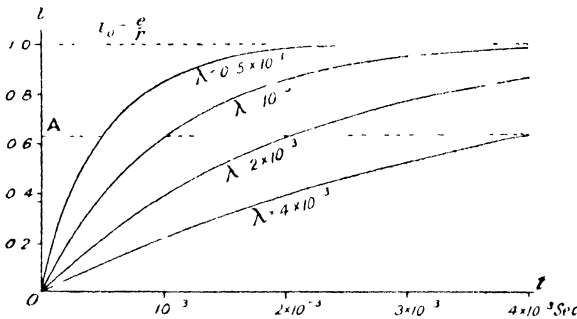

FIG 301.

The ratio $\frac{l}{r}$ is called the *Time Constant*, λ , of the circuit, and the equation for the current may be written —

$$i = i_0(1 - e^{-\frac{t}{\lambda}}).$$

After time λ ,

$$i = i_0 \left(\frac{e - 1}{e} \right) \\ = i_0 \frac{1.718}{2.718} = 0.632i_0.$$

Thus the time constant is the time in which a current reaches $\frac{1.718}{2.718}$ or roughly two-thirds of its final value. The four curves in Fig. 301 are drawn for values of the time constant equal to 4×10^{-3} , 2×10^{-3} , 10^{-3} , and 0.5×10^{-3} , and the time taken for each current to reach the line A, where $OA = 0.632i_0$, is the time constant.

The variation in rate of growth of the current cannot be observed with an ordinary galvanometer, but by using one having a very high frequency for its moving part, as for example the vibration galvanometer (p. 380) the difference in rates of growth of current in an electromagnet and in an equal resistance having small inductance may easily be demonstrated.

Decay of Current.—If, when the steady value i_0 of the current has been reached, the electromotive force be suddenly reduced to zero, the variation of the current may be found, for e in our E.M.F. equation is then zero.

$$l \frac{di}{dt} + ri = 0.$$

Transforming the equation as before, we get—

$$-\frac{l}{r} \cdot \frac{di}{i} = dt$$

and integrating,

$$\frac{l}{r} \cdot \log_e i = -t + k.$$

When $t = 0$, $i = i_0$.

$$\therefore \frac{l}{r} \log_e i_0 = k,$$

and substituting this value for k , we have—

$$\log_e \frac{i}{i_0} = -\frac{r}{l} t,$$

or,

$$i = i_0 e^{-\frac{r}{l} t}$$

$$= i_0 e^{-\frac{t}{\lambda}}$$

Thus the greater the value of λ , the more slowly will the current die away. Fig. 302 illustrates the decay of the current for $\lambda = 4 \times 10^{-3}$, 2×10^{-3} , 10^{-3} , and 0.5×10^{-3} .

It will be noticed that the growing and decaying currents are complementary, for if the currents $i_0(1 - e^{-\frac{t}{\lambda}})$ and $i_0 e^{-\frac{t}{\lambda}}$ be added

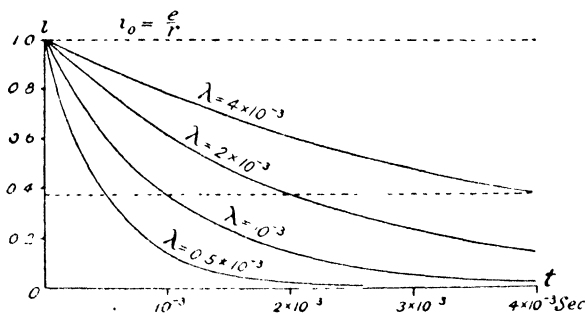

FIG. 302.

together, the sum is i_0 . Hence the curves in Fig. 302 are those of Fig. 301 inverted.

The variation in rate of decay of the current in different circuits may be demonstrated by means of the vibration galvanometer in a manner similar to that described for the growing current (p. 305), but in this case the circuit must be closed as the battery is cut out; it must not merely be broken, as this would introduce an infinite resistance. The result of this increase in resistance is that the time constant of the circuit is reduced and the current drops at an enormous rate. The electromotive force due to inductance, being proportional to the rate of change of current, is then enormous, and is sufficient to cause a spark or even an arc at the break in the circuit.

Inductance in electrical problems plays a similar part to mass or inertia in mechanical problems; its effect is to retard the growth of the current or the motion, and similarly neither the current nor the motion can be stopped instantaneously. The energy due to the magnetic field linked with the current is $\frac{1}{2}li^2$ ergs; that due to the inertia of a moving mass is $\frac{1}{2}mv^2$ ergs.

Inductance of Solenoid.—In certain simple cases, the self-inductance of a circuit may be calculated from the definition $e = -l \cdot \frac{di}{dt}$, provided of course that the permeability is constant. In the case of a solenoid having an air core, if b be its length, n the total number of turns, and a its area of cross-section—

$$\begin{aligned} \text{Field inside solenoid} &= \frac{4\pi ni}{b}, & (\text{p. 232}) \\ \text{magnetic flux} &= \frac{4\pi nai}{b}. \end{aligned}$$

If the solenoid is straight b must be great.

When i varies, any change in the flux cuts the circuit n times,

$$\begin{aligned} \therefore e &= -n \frac{d}{dt} \left(\frac{4\pi nai}{b} \right) \\ &= -\frac{4\pi n^2 a}{b} \cdot \frac{di}{dt}. \end{aligned}$$

By comparison with the above equation for l we see that—

$$l = \frac{4\pi n^2 a}{b}.$$

Coaxial Cylinders.—When the circuit consists of two coaxial cylinders of radii a and b , one being the return circuit for the other, the magnetic field is confined to the space between them. For, a circular path taken externally round them both encloses equal and

opposite currents (Fig. 303) and, therefore, the line integral of the magnetic field round the path is zero. Again, within the inner cylindrical current the magnetic field is zero, for a closed path in this region does not enclose any current. It follows that the resultant magnetic field is confined to the space between the cylinders and is that due to the current i in the inner cylinder. At external points, the magnetic fields due to the two cylinders are equal and opposite. This proves incidentally that the field due to a cylindrical current is the same at external points, as though the current flowed along the axis, for the inner cylinder may be reduced to as small dimensions as we please.

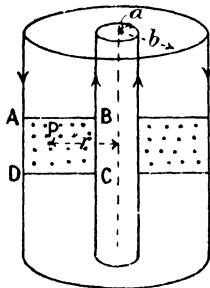

FIG. 303.

The value of H at the point P is therefore $\frac{2i}{r}$ and the flux through the area $ABCD$, where AD has unit length, is—

$$\int_a^b \frac{2i}{r} dr = 2i \left[\log_e r \right]_a^b.$$

$$N = 2i \log_e \frac{b}{a}.$$

Now when i varies—

$$e = - \frac{dN}{dt}$$

$$= - 2 \log_e \frac{b}{a} \cdot \frac{di}{dt}.$$

But,

$$e = - l \frac{di}{dt}.$$

$$\therefore l = 2 \log_e \frac{b}{a}$$

per unit length of the coaxial cylinders.

Practical Unit (the Henry).—In the foregoing equations, all the quantities have been given in absolute C.G.S. units, but in practical work it is desirable to employ a unit in conformity with the system—volt, ampere, ohm, etc. The unit chosen is called the *Henry*, and is the inductance of a circuit in which a rate of change of current of one ampere per second produces an electromotive force of one volt. The relation of the henry to the absolute unit of inductance may be found in a manner analogous to that employed in the case of the ohm (p. 62). The volt is equal to 10^8 absolute units of electromotive force and the ampere to 10^{-1} unit of current, whereas the second is the unit of time on both systems, and thus, since—

$$e = l \frac{di}{dt}; \quad L = \frac{\text{E volts}}{\frac{dI}{dt} \text{ amperes per sec.}} \text{ henrys,}$$

$$\text{or, 1 henry} = \frac{1 \text{ volt}}{1 \text{ ampere per sec.}} = \frac{10^8 \text{ absolute units of E.M.F.}}{10^{-1} \text{ absolute unit of current per sec.}} \\ = 10^9 \text{ absolute units of inductance.}$$

Thus the inductance of a solenoid—

$$= \frac{4\pi n^2 a}{10^9 b} \text{ henrys,} \quad (\text{p. 307})$$

and that of the coaxial cylinders on p. 308 is $2 \times 10^{-9} \log_e \frac{b}{a}$ henry.

In future we shall use the letter l to represent inductance in absolute units, and L that in henrys.

A convenient form of variable inductance made by Messrs. Nalder Bros. & Co., Ltd., is shown in Fig. 304. The two coils are in series,

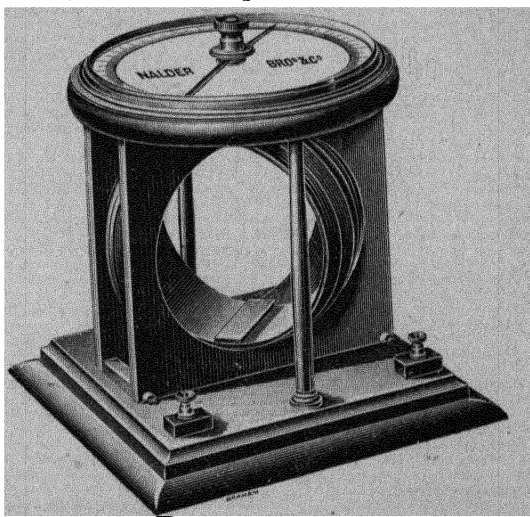

FIG. 304.

and one of them can be rotated so as to vary the resultant magnetic flux due to the two. The scale on the instrument is calibrated in millihenrys.

Charge and Discharge of Condenser.—On applying an electromotive force e , due to some external source, to a circuit consisting of a capacity in series with a resistance, a current will flow for a time, but electric charge is all the time accumulating upon the plates of the condenser, and for charge q , the difference of potential between the plates is $\frac{q}{c}$, where c is the capacity of the condenser; and this is directed one particular way round the circuit. A current in one direction will increase this, giving energy to the condenser, and in the other the energy of the charge on the condenser will be used in driving

the current. Hence the condenser produces an electromotive force in the circuit, and the equation of electromotive forces becomes—

$$ri + \frac{q}{c} = e$$

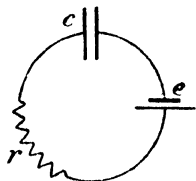

FIG. 305.

Now the current in every part of the circuit being the same, it is equal to the rate at which charge accumulates in the condenser.

$$i = \frac{dq}{dt}, \text{ or, } q = \int i dt,$$

$$\therefore r \frac{dq}{dt} + \frac{q}{c} = e.$$

This equation may be solved in a similar manner to that on p. 303.

$$\text{Thus, } -cr \cdot \frac{d\left(\frac{e - \frac{q}{c}}{r}\right)}{\left(\frac{e - \frac{q}{c}}{r}\right)} = dt$$

$$cr \log_e \left(\frac{e - \frac{q}{c}}{r}\right) = -t + k.$$

If $q = 0$, when $t = 0$ —

$$cr \log_e \frac{e}{r} = k.$$

$$\therefore \log_e \frac{e - \frac{q}{c}}{e} = -\frac{t}{cr}$$

$$q = ec(1 - e^{-\frac{t}{cr}})$$

ec is the final steady charge in the condenser; calling this q_0 we have—

$$q = q_0(1 - e^{-\frac{t}{cr}}).$$

The time constant in this case is cr ,

$$\therefore q = q_0(1 - e^{-\frac{t}{\lambda}}).$$

If now the external electromotive force be reduced to zero, the E.M.F. equation becomes—

$$r \frac{dq}{dt} + \frac{q}{c} = 0,$$

whence,

$$\frac{dq}{q} = -\frac{dt}{cr}$$

$$\log_e q = -\frac{t}{cr} + k.$$

If $q = q_0$, when $t = 0$ —

$$k = \log_e q_0$$

or,

$$\log_e \frac{q}{q_0} = -\frac{t}{cr},$$

$$\therefore q = q_0 e^{-\frac{t}{cr}} = q_0 e^{-\frac{t}{\lambda}}.$$

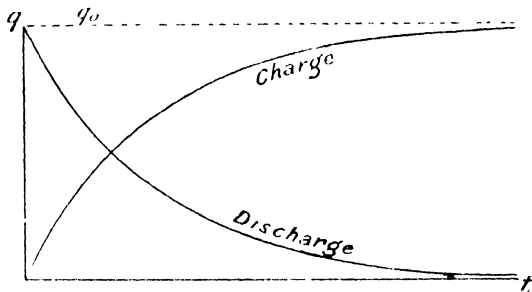

FIG. 306.

The curves for q and t for charge and discharge are drawn in Fig. 306.

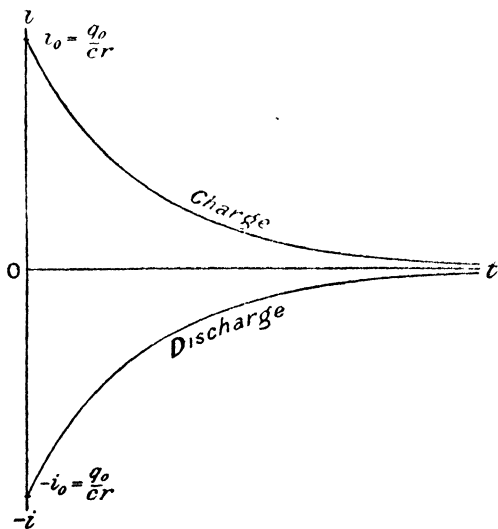

FIG. 307.

The equations for the current may be obtained from those for the charge, remembering that $i = \frac{dq}{dt}$.

Thus, for the charge—

$$i = q_0 \frac{d}{dt} (1 - \epsilon^{-t/cr}) = \frac{q_0}{cr} \epsilon^{-t/cr}$$

and for the discharge—

$$i = q_0 \frac{d}{dt} (\epsilon^{-t/cr}) = -\frac{q_0}{cr} \epsilon^{-t/cr}.$$

Since

$$e = \frac{q_0}{c},$$

$$\frac{q_0}{cr} = \frac{e}{r} = i_0,$$

i_0 being the value of the current at the beginning of both charge and discharge. It may be noticed that in both cases the current starts with its greatest value and falls off exponentially; the discharging current is negative, that is, it is in the reverse direction to the charging current (Fig. 307).

Measurement of High Resistance by Leakage.—From the equation for the discharge, we see that q falls to about one-third of its value in time $\lambda = cr$; for, $\frac{q}{q_0} = \epsilon^{-t/\lambda} = \frac{1}{3}$, when $t = \lambda$. If the time t is to be measured with reasonable accuracy, it must be over a minute, say 100 seconds. Therefore cr must be at least 100. Now the condensers of convenient size, found in every laboratory, have a capacity of the order of a micro-farad, that is 10^{-6} farad, or 10^{-15} absolute units, where the practical unit of capacity, the *Farad*, is the condenser which one coulomb will charge to a potential difference of one volt. Hence for cr to have the value 100, when c is 10^{-15} , r must have a value of 10^{17} absolute units or 10^8 ohms. Hence a capacity of 1 micro-farad discharging through a resistance of 10^8 ohms or 100 megohms (1 megohm = 10^6 ohms) will lose about two-thirds of its charge in 100 seconds.

This gives rise to a convenient practical method of measuring resistances of the order of 20 megohms and upwards; for the condenser is charged and then allowed to discharge through the resistance for a known time t . From the relation—

$$\log_{\epsilon} \frac{q}{q_0} = -\frac{t}{cr},$$

or,

$$r = \frac{t}{c \log_{\epsilon} \frac{q_0}{q}},$$

c being known and $\frac{q_0}{q}$ being observed, r can be calculated. When the

rate of leakage is small, $\frac{q_0}{q}$ may be measured by means of the quadrant electrometer, the deflection being read at known intervals.

$$\frac{\theta_1}{\theta_2} = \frac{e_0}{e} = \frac{q_0}{q}.$$

Or the condenser may be charged and instantly discharged through the ballistic galvanometer. The throw θ_1 is then proportional to q_0 . It is again charged and allowed to leak for t seconds through the resistance and then discharged through the galvanometer. The throw θ_2 is then proportional to the charge q remaining after t seconds, so that—

$$r = \frac{t}{c \log_e \frac{\theta_1}{\theta_2}}$$

It is advisable to obtain a number of readings of t and θ by repeating the above process and plotting a curve of t and $\log_e \frac{\theta_1}{\theta_2}$. A straight line lying evenly amongst these points may be drawn and from it a mean value of $\frac{t}{\log_e \frac{\theta_1}{\theta_2}}$ obtained, from which r may be calculated.

Mutual Inductance.—We have already seen that a variation of the current in a circuit is accompanied by an electromotive force in any neighbouring circuit (p. 247). Thus if the current in the circuit A (Fig. 248) varies, there will be an electromotive force in the circuit B, equal to $-m \frac{di}{dt}$ due to this variation of the current in A. m is called the *coefficient of mutual induction* or the *mutual inductance* of the two circuits. The defining of mutual inductance is subject to all the difficulties encountered in the case of self-inductance when the magnetic permeability is variable (p. 302). It may be defined as above, or as the magnetic flux linked with the secondary circuit B, due to unit current in the primary A. Thus—

$$e = - \frac{dN}{dt} = - \frac{d(mi)}{dt} = -m \frac{di}{dt}$$

when m is constant.

m may also be defined as the mutual potential energy of the two circuits when unit current is flowing in each, and this again leads to the same value of m when the permeability is constant.

Let i_2 be the current in the secondary circuit, and let it be situated in a magnetic field whose value at the point P, Fig. 308 (i), is H , θ being the angle between the field and the circuit at P. Then the force per unit length of the circuit is $i_2 H \sin \theta$ (see p. 239), and for the small

length l of the circuit, is $i_2 H l \sin \theta$, and is at right angles to l and H . Let the element l be displaced in the direction of the force by an amount δx , then work done = $i_2 H \sin \theta \cdot l \cdot \delta x$.

But $H \sin \theta$ is the component of H normal to the area $l \cdot \delta x$ swept out by the element (Fig. 308 (ii)), and therefore $H \sin \theta \cdot l \cdot \delta x$ is the amount of magnetic flux dN added to or withdrawn from the total amount linked with the circuit. Hence—

$$\text{work done} = i_2 dN,$$

and $\int i_2 dN$ is the total work done when the magnetic flux N , linked with the circuit, changes by the amount $\int dN$, i_2 being constant.

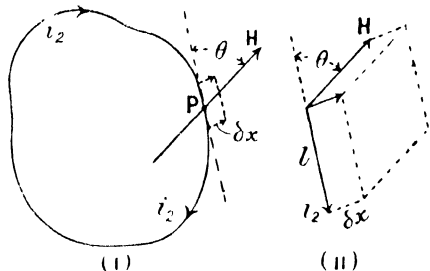

FIG. 308.

It is immaterial whether the circuit changes in size, or whether the change in N is due to the alteration in the distribution of the flux, for the work done at each element of the circuit is proportional to the value of H at the point, and to the relative motion of the circuit and the flux; in fact the problem is similar to that of finding the work done in the case of the change of volume of a gas, which is $\int p dv$, where p is the pressure at the boundary and dv a small change in volume. The same limitations as regard reversibility apply in the two cases. If the permeability is not unity H must be replaced by B in the above.

If now the flux N is due to another circuit carrying current i_1 , the flux due to it and linked with both circuits is $m_1 i_1$, and therefore $m_1 i_1 i_2$ is the work done in linking the flux $m_1 i_1$ with, or withdrawing it from i_2 . Similarly the current i_2 involves a flux $m_2 i_2$ linked with i_1 , and to withdraw this flux from i_1 involves an amount of work $m_2 i_2 i_1$. These two amounts of work must be the same, for if the two circuits be separated to a great distance, the forces on the two at each instant during the act of separation must be equal and opposite.

$$\therefore m_1 i_1 i_2 = m_2 i_2 i_1 \\ m_1 = m_2,$$

and,

so that there is only one value of the mutual inductance between the two circuits, and the flux linked with the second due to unit current in the first is equal to the flux linked with the first due to unit current in the second.

Calculation of Mutual Inductance.—In any case in which the flux linked with the secondary circuit due to current i in the primary circuit can be calculated, the mutual inductance may be deduced from the relation $e = -m \frac{di}{dt}$. Thus for the solenoid (Fig. 260) in which n

turns of secondary are wound near the middle of a primary of n_1 turns per unit length—

$$H = 4\pi n_1 i, \text{ and, } N = 4\pi n_1 A i.$$

This is the flux linked with each turn of the secondary.

$$\begin{aligned} \therefore e &= -n_2 \cdot \frac{d}{dt} (4\pi n_1 A i) \\ &= -4\pi n_1 n_2 A \cdot \frac{di}{dt} \end{aligned}$$

from which,

$$m = 4\pi n_1 n_2 A.$$

If the flux due to the current in the primary is not all linked with the secondary, as, for example, when the secondary turns are not all wound near the middle of the solenoid, the mutual inductance will be less than the above amount.

In the case of two identical circuits wound so that they practically coincide with each other everywhere, the mutual inductance would be equal to the self-inductance of either.

From the identity in form of the quantities self, and mutual, inductance they are measured in the same units. Thus the henry is the practical unit of mutual inductance, and is the mutual inductance of a pair of circuits when a rate of change of one ampere per second in one, causes an electromotive force of one volt in the other. We shall write “ m ” for mutual inductance measured in absolute units, and “ M ” for that measured in henrys.

In comparing inductances experimentally, it is often convenient to have a variable standard of inductance, but in the case of self-inductance there is the difficulty that the low values cannot be obtained, since, however the positions of the two parts of the circuit (see Fig. 304) are varied, the self-inductance can never be reduced to zero. Mr. A. Campbell¹ has suggested instead, the employment of standards of mutual inductance, since this can be varied for two coils from zero, or even a negative value, up to a maximum, by altering the relative positions of the primary and secondary coils.

Current in Secondary.—On starting the current in the primary circuit, we have seen that there is a current in the secondary, which ceases when that in the primary has become steady. Further, on stopping the primary current we again get a transient current in the secondary. To find the value of the current in the secondary at any moment, we must write the electromotive force equations for the two circuits and then obtain a solution. Let i_1 , l_1 , and r_1 , i_2 , l_2 , and r_2 , be the currents, inductances and resistances of the two circuits, and m the mutual inductance; then for the primary—

$$l_1 \frac{di_1}{dt} + m \frac{di_2}{dt} + r_1 i_1 = e,$$

¹ A. Campbell, *Proc. Roy. Soc., Ser. A.*, 79, p. 428. 1907

and for the secondary—

$$L_2 \frac{di_2}{dt} + m \frac{di_1}{dt} + r_2 i_2 = 0.$$

To obtain the equations for the primary and secondary currents, these two simultaneous equations must be solved. The mathematics involved is beyond the scope of this work, but the currents may be plotted by the step by step method with the help of these equations.

Writing them in the form—

$$\frac{L_1 di_1}{r_1 dt} + \frac{m di_2}{r_1 dt} = \frac{e}{r_1} - i_1 = i_0 - i_1,$$

and

$$\frac{L_2 di_2}{r_2 dt} + \frac{m di_1}{r_2 dt} = -i_2,$$

where i_0 is the final steady value of the current in the primary, we can then solve the simultaneous equations for $\frac{di_1}{dt}$ and $\frac{di_2}{dt}$. This gives us—

$$\begin{cases} \frac{di_1}{dt} = \frac{(i_0 - i_1)L_2 r_1 + i_2 m r_2}{L_1 L_2 - m^2} \\ \frac{di_2}{dt} = -\frac{(i_0 - i_1)m r_1 + i_2 L_1 r_2}{L_1 L_2 - m^2}, \end{cases}$$

or,

$$\begin{cases} di_1 = \frac{(i_0 - i_1)L_2 r_1 + i_2 m r_2}{L_1 L_2 - m^2} dt \\ di_2 = -\frac{(i_0 - i_1)m r_1 + i_2 L_1 r_2}{L_1 L_2 - m^2} dt. \end{cases}$$

If small intervals of time, dt , be taken, we can begin with any values of i_1 and i_2 we please, say $i_1 = 0$ and $i_2 = 0$, and find the values of di_1 and di_2 for the first interval. From these we know the values of i_1 and i_2 for the beginning of the second interval and can then calculate di_1 and di_2 for the second interval. This process may be repeated until i_1 has reached its steady value and i_2 has again become zero. The first two curves in Fig. 309 have been obtained in this way, taking $L_1 = 10$ henrys, $L_2 = 1$ henry and $M = 0.8$ henry, $R_1 = 10$ ohms, $R_2 = 1$ ohm, and $E = 10$ volts, in which case the equations are written—

$$\begin{cases} dI_1 = \frac{(I_0 - I_1)L_2 R_1 + I_2 M R_2}{L_1 L_2 - M^2} dt, \\ dI_2 = -\frac{(I_0 - I_1)M R_1 + I_2 L_1 R_2}{L_1 L_2 - M^2} dt \end{cases}$$

and $I_0 = 1$ ampere. It will be seen that after six seconds the steady state has been very nearly reached. The dotted curve gives the growth of the primary current when there is no secondary circuit.

The second curves have been drawn for the falling primary current. They may be obtained by putting $E = 0$ in the differential equations, whence—

$$\begin{cases} dI_1 = \frac{-I_1 I_2 R_1 + I_2 M R_2}{L_1 L_2 - M^2} dt \\ dI_2 = \frac{+I_1 M R_1 - I_2 L_1 R_2}{L_1 L_2 - M^2} dt, \end{cases}$$

and taking the initial value of I_1 to be I_0 , i.e. $\frac{E}{R_1}$.

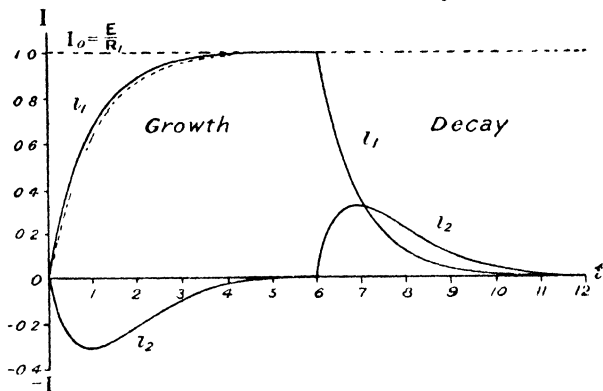

FIG. 309.

Charge Flowing in Secondary Circuit.—The quantity of electricity that has been caused to circulate in the secondary circuit at either the starting or the stopping of the primary current, is $\int_0^{\infty} i_2 dt$ and is the area included between the i_2 curve and the axis (Fig. 309). It may also be found from the equation—

$$\frac{l_2}{r_2} \cdot \frac{di_2}{dt} + \frac{m}{r_2} \cdot \frac{di_1}{dt} + i_2 = 0,$$

Integrating this with respect to time, from zero to infinity, we get—

$$\frac{l_2}{r_2} \int_0^{\infty} \frac{di_2}{dt} dt + \frac{m}{r_2} \int_0^{\infty} \frac{di_1}{dt} dt = - \int_0^{\infty} i_2 dt.$$

Now at time 0, $i_2 = 0$, and, $i_1 = 0$,
and at time t , $i_2 = 0$, and, $i_1 = i_0$.
Therefore the first term is zero at both limits, and—

$$\frac{m}{r_2} \int_0^{i_0} di_1 = - \int_0^{\infty} i_2 dt.$$

Now $\int_0^{\infty} i_2 dt$ is the quantity of electricity that has circulated in the

secondary circuit, and therefore it is equal to $-\frac{mi_0}{r_2}$. When the current is stopped, the limits 0 and i_0 are reversed, and therefore the quantity is $\frac{mi_0}{r_2}$.

Divided Circuits.—By a similar method we may prove that when

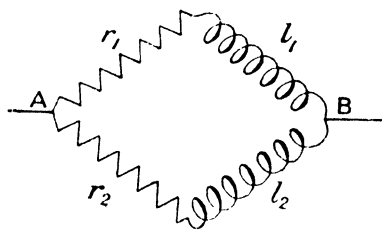

FIG. 310.

a quantity of electricity passes through two circuits in parallel, it divides between them in the inverse ratio of the resistance, just as a steady current would do, the inductances of the parallel circuits having no effect upon the ratio in which the charge divides. Let the two circuits have resistance r_1, r_2 and inductance l_1, l_2 respectively, and

e be the impressed electromotive force acting between the points A and B (Fig. 310).

For the first circuit—

$$l_1 \frac{di_1}{dt} + r_1 i_1 = e,$$

and for the second—

$$l_2 \frac{di_2}{dt} + r_2 i_2 = e.$$

Since they are in parallel e is the same for both.

$$\therefore l_1 \frac{di_1}{dt} + r_1 i_1 = l_2 \frac{di_2}{dt} + r_2 i_2.$$

Hence—

$$l_1 \int_0^t \frac{di_1}{dt} dt + r_1 \int_0^t i_1 dt = l_2 \int_0^t \frac{di_2}{dt} dt + r_2 \int_0^t i_2 dt.$$

Now if the current is zero before and after the passage of the charge—

$$\int_0^t \frac{di_1}{dt} dt = \int_0^0 di_1 = 0, \quad \text{and similarly,} \quad \int_0^t \frac{di_2}{dt} dt = 0,$$

and further,

$$\int_0^t i_1 dt = q_1,$$

and,

$$\int_0^t i_2 dt = q_2,$$

$$\therefore r_1 q_1 = r_2 q_2$$

or,

$$\frac{q_1}{q_2} = \frac{r_2}{r_1}$$

Hence in comparing capacities by means of the ballistic galvanometer, a shunt may be employed to reduce the throw, since the charge divides exactly as a steady current would do, the ratio in which the division takes place being unaffected by the inductances of the shunt and galvanometer. It does not follow that the currents at each instant will be inversely as the resistances: they will not. For let $l_1 = 0$; then the current in the first branch will be in excess of that calculated from the resistances, while the currents are growing. But it will be less while the currents are decaying and may even be reversed, owing to the inductance l_2 . All that is implied by the above calculation is, that the total charges passing through the two branches are inversely as the resistances.

The Induction Coil.—A particular use of mutual inductance, of great practical importance, is made in the case of the induction coil, which is a piece of apparatus for producing small currents at very high electromotive force from comparatively large currents at low electromotive force. The primary coil PP (Fig. 311), consisting of a number of turns of thick wire, is wound upon an iron core D built up of a number of strands of soft-iron wire, while the secondary coil SS has a great number of turns of fine wire, and is wound upon the primary. On starting the current in the primary, the magnetic flux

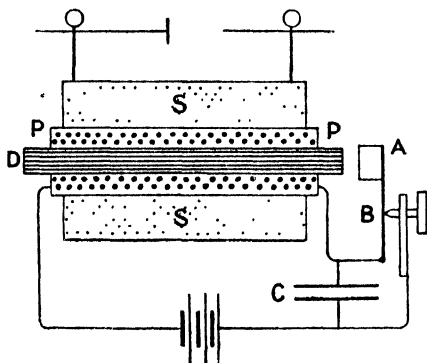

FIG. 311.

produced in the core cuts the secondary, producing a high electromotive force, and when the primary current is stopped, the flux again cuts the secondary but in the opposite direction, causing a reversed electromotive force. Many induction coils are provided with an automatic make and break, which consists of a spring having at its extremity a soft-iron armature A which is attracted towards the core when the primary current is made. This breaks the primary circuit at B, and on the core becoming demagnetised the spring recovers its original position and makes the circuit again by means of the contact B, and the process is then repeated. As considerable sparking occurs at B when the circuit is broken, the surfaces that come into contact are faced with platinum to prevent undue sparking and wearing away.

Although an electromotive force is produced in the secondary coil at both make and break of the primary circuit, the latter is by far the greater, since the primary current dies away much more rapidly than it grows. When the circuit is closed, its resistance is small and its time

constant $\left(\frac{l}{r}\right)$ great, but when the circuit is broken r is enormously increased and the time constant correspondingly reduced; thus the rate of decay of the primary current is high. The magnetic flux in the core is therefore removed much more rapidly than it is produced, and the electromotive force in the secondary is much higher at the break of the primary circuit than at the make. On this account the electromotive force in the secondary circuit at the make is usually insufficient to produce a discharge through the gas surrounding the secondary terminals, and the secondary current is therefore unidirectional.

The manner in which the secondary current rises and falls on each break of the primary circuit may be seen from Fig. 309.

The efficiency of the coil is much increased if a condenser be placed in parallel with the contact breaker of the primary circuit, for the primary coil and the condenser comprise a circuit in which electrical oscillations occur, the condenser at the end of the first half oscillation being charged oppositely to its condition at the instant of break. The magnetic flux in the core due to the primary current is therefore reversed at each break, and the amount of charge caused to circulate in the secondary approaches double the value in this case, of that when no condenser is used, for without condenser the primary current merely drops to zero on account of the high resistance introduced at the break. The oscillations in the primary current will be rapidly damped, owing to the loss of energy due to heating produced by the currents in both primary and secondary, so that only the first discharge is of importance.

The effect of the condenser upon the secondary current may be found, on neglecting the effect of the resistance of the secondary at the beginning of the discharge. This is, to a first approximation, justified, for when the secondary current is varying rapidly, as at the beginning of the discharge, the predominant factor in determining its rate of growth is the large inductance of the secondary circuit.

The E.M.F. equations for the two circuits are therefore—

$$l_1 \frac{di_1}{dt} + m \frac{di_2}{dt} + r_1 i_1 = 0$$

$$\text{and,} \quad l_2 \frac{di_2}{dt} + m \frac{di_1}{dt} = 0.$$

Multiplying the first by l_2 and the second by m and subtracting, we have—

$$(l_1 l_2 - m^2) \frac{di_1}{dt} + l_2 r_1 i_1 = 0,$$

the solution to which is—

$$i_1 = i_0 e^{-\frac{l_2 r_1}{l_1 l_2 - m^2} t} \quad (\text{see p. 306}).$$

Writing a for $\frac{l_2 r_1}{l_1 l_2 - m^2}$, we have—

$$i_1 = i_0 \epsilon^{-at}$$

i_0 is here the current in the primary at the moment of breaking the circuit.

Integrating the E.M.F. equation for the secondary circuit, we have—

$$l_2 i_2 + m i_1 = k$$

where k is a constant.

$$\therefore l_2 i_2 + m i_0 \epsilon^{-at} = k.$$

If $i_2 = 0$ when $t = 0$, then—

$$k = m i_0$$

and,

$$i_2 = \frac{m}{l_2} i_0 (1 - \epsilon^{-at}).$$

As t increases to infinity this gets nearer and nearer to the value $\frac{m}{l_2} i_0$, but we must remember that this would only be true if the resistance of the secondary circuit were zero, which is far from being the case. From the start, the effect of the resistance is to decrease the current, and a short time after the electromotive force due to variation in the primary current has reached zero, the secondary current will also become zero. The value $\frac{m i_0}{l_2}$ is the limit which the secondary current cannot exceed, and would only reach if the resistance were zero.

When the resistance r has been replaced by a condenser of capacity c , the maximum value of the secondary current may be obtained approximately by a method given by Lord Rayleigh,¹ which suggested the above. The electromotive force equation for the primary circuit being—

$$l_1 \frac{di_1}{dt} + m \frac{di_2}{dt} + \frac{q}{c} = 0,$$

or,

$$l_1 \frac{d^2 q_1}{dt^2} + m \frac{d^2 q_2}{dt^2} + \frac{q}{c} = 0,$$

and for the secondary,

$$l_2 \frac{di_2}{dt} + m \frac{di_1}{dt} = 0,$$

or,

$$l_2 \frac{d^2 q_2}{dt^2} + m \frac{d^2 q_1}{dt^2} = 0.$$

Multiply the first by l_2 and the second by m , and subtract, and we get—

$$(l_1 l_2 - m^2) \frac{d^2 q_1}{dt^2} + \frac{l_2}{c} q = 0.$$

¹ Hon. J. W. Strutt, *Phil. Mag.* (Ser. 4), 39, p. 428. 1870

This is of the type $\frac{d^2x}{dt^2} + k^2x = 0$, which was solved on page 22.

It is of the simple harmonic or oscillatory type, and we therefore see that the motion of the charge in the primary circuit is oscillatory. Consequently the current is likewise oscillatory, and varies between the limits $+i_0$ and $-i_0$.

The solution of the equation—

$$l_2 \frac{di_2}{dt} + m \frac{di_1}{dt} = 0$$

is,

$$l_2 i_2 + m i_1 = k,$$

and if $i_1 = i_0$, when $i_2 = 0$ —

$$k = m i_0,$$

and,

$$i_2 = \frac{m}{l_2} (i_0 - i_1).$$

Since i_1 varies between the limits $+i_0$ and $-i_0$, the greatest value of i_2 occurs when $i_1 = -i_0$, in which case—

$$i_2 = \frac{2m i_0}{l_2}.$$

It will be seen that this is twice the greatest value of the secondary current when the condenser is absent, the drop in the primary current being produced merely by the break at the contact maker. Since the charge passes into the condenser instead of across the gap the sparking at the break is much reduced.

Practical Methods of Measuring Inductances.—The mutual inductance of two coils may be measured by making use of the fact that the quantity of electricity caused to circulate in one when current I is established in the other is $\frac{MI}{R}$ coulombs (p. 317). Thus, with the plug in A (Fig. 312) the ballistic throw in the galvanometer G when the current I is started or stopped in the primary circuit may be observed.

$$\text{Then } \frac{MI}{R} = Q = \frac{cT}{2\pi AH} \theta \text{ (see p. 254).}$$

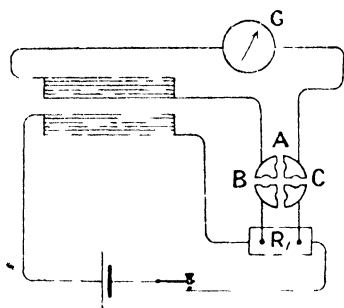

FIG. 312.

In order to determine $\frac{c}{AH}$, the plug is removed from A, and two are placed in B and C, which are connected to a very small resistance, R_1 , say $\frac{1}{100}$ ohm, in the primary circuit. The difference of potential between the ends of this is now IR_1 and a current $\frac{IR_1}{R}$ flows in the secondary circuit, giving a steady galvanometer deflection θ_1 .

Then,

$$\frac{IR_1}{R} \cdot \frac{AH}{c} = \theta_1$$

$$\therefore \frac{MI}{R} = \frac{IR_1}{R\theta_1} \cdot \frac{T}{2\pi} \theta,$$

$$M = \frac{R_1 T}{2\pi\theta_1} \cdot \theta.$$

The time of vibration T of the galvanometer needle may be found in the usual way.

Self-Inductance (Rayleigh's Method¹).—As in the last method, an inductance is measured in terms of a resistance and a time, but here the Wheatstone's bridge is employed. The inductance to be measured is placed in the arm AB of the bridge (Fig. 313) and a balance for steady current obtained in the ordinary way, the battery key being closed before the galvanometer key (not shown in the diagram). On closing the battery key with the galvanometer key already closed, a throw will be obtained, since the balance is disturbed while the current is growing, owing to the extra electromotive force $L \frac{dI}{dt}$ in the arm AB. Any electromotive force in one arm of the bridge causes a proportionate current in every part of the bridge. Let kE be the current in the galvanometer due to electromotive force E in the arm AB.

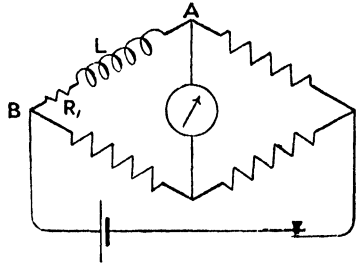

FIG. 313.

Then the instantaneous current in the galvanometer due to electromotive force $L \frac{dI}{dt}$ in AB is $kL \frac{dI}{dt}$, and therefore the total quantity of electricity that flows through the galvanometer due to this cause, while the current I_0 is being established in AB is—

$$\int_0^t k \cdot L \frac{dI}{dt} dt = kL \int_0^{I_0} dI$$

$$= kLI_0.$$

$$\therefore kLI_0 = \frac{cT}{2\pi AH} \theta \left(1 + \frac{\lambda}{2}\right)$$

where θ is the throw, and λ the logarithmic decrement.

In order to determine $\frac{L I_0 AH}{c}$, the resistance in AB is changed by amount R_1 , which is so small that there is no appreciable change in the current I_0 . The effect is to introduce the small electromotive

¹ Lord Rayleigh, *Phil. Trans.*, 173, p. 677. 1882.

force $I_0 R_1$ into the arm AB and to produce a steady current $kI_0 R_1$ in the galvanometer. The steady deflection θ_1 produced is given by—

$$\begin{aligned} kI_0 R_1 A H &= c \theta_1 \\ \therefore \frac{kI_0 A H}{c} &= \frac{\theta_1}{R_1} \end{aligned}$$

and substituting in the above equation, we get—

$$L = \frac{R_1 T}{2\pi \theta_1} \theta \left(1 + \frac{\lambda}{2} \right).$$

The balance for steady current must be perfect. When the metre bridge is being used this condition is easily attained, but owing to the low resistance of the bridge wire, a Post-Office box, or a suitable combination of resistance boxes, is used by preference. In this case the smallest resistance in the box is usually sufficient to change the steady deflection from one side to the other, and hence a perfect balance cannot be obtained. To get over this difficulty, one of the connections between the boxes may be made with platinoid or manganin wire and the final adjustment carried out by slipping the wire in the necessary direction through the terminal. The small resistance R_1 may be a standard 0.1, 0.01 or 0.001 ohm, included in the arm AB.

Comparison of Self-Inductances.—The value of a self-inductance in terms of a standard, may be found by placing them one in each

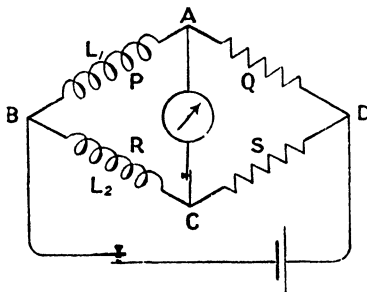

FIG. 314.

adjacent arm of a Wheatstone's bridge, and adjusting the resistances until a balance is obtained for an intermittent, as well as for a steady current. If P, Q, R, and S are the respective resistances of the arms of the bridge (Fig. 314) we have, when a balance for steady current is obtained, $\frac{P}{R} = \frac{Q}{S}$.

On closing the galvanometer key and afterwards the battery

key, a galvanometer throw will be observed, unless we have the additional relation $\frac{L_1}{L_2} = \frac{P}{R} = \frac{Q}{S}$.

For the points A and C are at the same potential before the current starts and also when it has become steady, that is, the potential difference between D and A is equal to that between D and C. If now the current grows at the same rate in both branches DAB and DCB, the differences of potential between D and A, and D and C respectively, are equal at every instant, and therefore A and C are

always at the same potential, and there will be no current in the galvanometer. The currents grow at the same rate if the time constants of the two circuits are equal, that is—

$$\frac{L_1}{P + Q} = \frac{L_2}{R + S}, \quad \text{or,} \quad \frac{L_1}{L_2} = \frac{P + Q}{R + S}.$$

But,

$$\frac{P}{R} = \frac{Q}{S} = \frac{P + Q}{R + S};$$

$$\therefore \frac{L_1}{L_2} = \frac{P}{R} = \frac{Q}{S}.$$

Either AB, or BC, must include a variable resistance, in order that the ratio $\frac{P}{R}$ may be varied. Hence it is necessary to produce a steady balance first; then if the ballistic balance is found to be imperfect, the ratio $\frac{P}{Q}$ must be altered and the process repeated. This is continued until the balance is perfect for both steady and variable currents.

In order to increase the sensitiveness to making or breaking the circuit, Ayrton and Perry designed a commutator which they called a Secohmmeter, which on rotation makes the battery, then the galvanometer circuits, then breaks the battery and afterwards the galvanometer circuits, so that the "break" impulses send a charge through the galvanometer when the ballistic balance is imperfect, but the "make" impulses do not. On reversing the direction of rotation, the charge passes through the galvanometer at the "make" instead of at the "break." The rotation is made rapid by a series of gearing wheels, so that a considerable number of "makes" or "breaks" may be made per second and the galvanometer deflection therefore increased.

Comparison of Capacities (de Sauty).—A method similar to the above may be applied to the comparison of capacities, but in this case the steady current is of course zero. On depressing the key (Fig. 315), a difference of potential is established between B and D and currents flow in the circuits BAD and BED. A and E are at the same potentials at the beginning and after the completion of the charging of the condensers, since the current in both cases is zero. If then the charges on the two condensers have grown at the same rate, A and E are all the time at the same potentials and there is no throw of the galvanometer. The charges grow at the same rate when the time constants

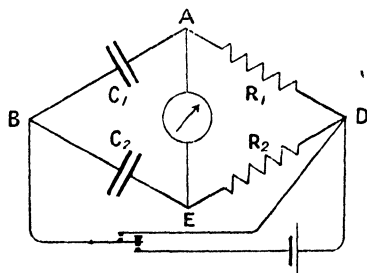

FIG. 315.

of the circuits BAD and BED are equal, that is when $R_1C_1 = R_2C_2$ (p. 310).

Therefore, when the resistances are adjusted until there is no disturbance of the galvanometer on charging or discharging, $\frac{C_1}{C_2} = \frac{R_2}{R_1}$.

When the balance is not attained, the throw is one way on charging by depressing the key, and the other way on discharging by releasing the key.

Comparison of Capacity with Self-Inductance. (i) (Maxwell¹).—A similar method was employed by Maxwell, the condenser C being placed

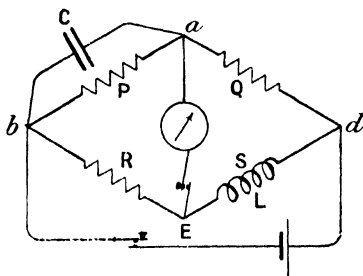

FIG. 316.

in parallel with the arm ab and the inductance placed in Ed (Fig. 316). Then, for a balance with steady current $\frac{P}{Q} = \frac{R}{S}$, and if in addition

no charge passes through the galvanometer on starting, we have the potential at a equal to that at E , during the whole time that the current is growing. If $p, q, r,$ and s are the instantaneous currents in the respective arms, the difference of potential between a and b is Pp ,

and the charge upon the condenser is CPp . The rate of flow of charge into the condenser is therefore $\frac{d(CPp)}{dt} = CP \cdot \frac{dp}{dt}$, and since there is no current through the galvanometer circuit, $q = p + CP \cdot \frac{dp}{dt}$; for the sum of the currents meeting at a must be zero.

Again, the difference of potential between d and E is $L \frac{ds}{dt} + Ss$, and that between d and a is Qq , and since these are equal, $L \frac{ds}{dt} + Ss = Qq$, and replacing q by its value $(p + CP \cdot \frac{dp}{dt})$, we have—

$$L \frac{ds}{dt} + Ss = Q \left(p + CP \cdot \frac{dp}{dt} \right).$$

Again, since difference of potential between b and a is equal to that between b and E —

$$\begin{aligned} Pp &= Rr = Rs, \\ \therefore P \frac{dp}{dt} &= R \frac{ds}{dt}, \end{aligned}$$

r being equal to s , and no current flowing through the galvanometer.

¹ Maxwell, "Electricity and Magnetism," vol. ii.

Substituting, we have—

$$L \frac{ds}{dt} + Ss = \frac{QR}{P} s + QCR \frac{ds}{dt}.$$

Now, $\frac{QR}{P} = S,$

$$\therefore L \frac{ds}{dt} = QCR \cdot \frac{ds}{dt}$$

or, $\frac{L}{C} = QR = PS$

(ii) (Rimington).—The process of finding the double balance is tedious, since it necessitates re-balancing for steady currents each time that the ballistic balance is found to be imperfect. The method has been modified by Rimington¹ in such a way that the steady balance when once obtained need not be disturbed. Instead of connecting the capacity permanently in parallel with the whole resistance P, one end is joined to *b* (Fig. 317) and the other is movable, and the adjustment consists in finding a position for the movable contact, such that on making or breaking the battery circuit no charge passes through the galvanometer.

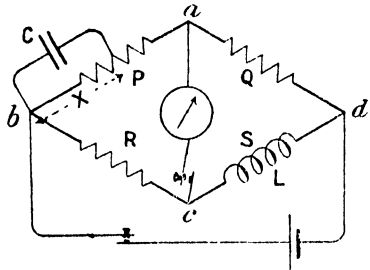

FIG. 317.

Let X be the resistance in parallel with the condenser when this condition is fulfilled, then if *x* is the current in it, and *p* the current in the remaining part of *ab*, whose resistance is *P* - *X*, we have as before—

$$\text{difference of potential between ends of condenser} = Xx.$$

Therefore charge in condenser is CX*x* and current into condenser is—

$$\frac{d(CXx)}{dt} = CX \frac{dx}{dt}$$

and since the currents meeting at the movable contact have resultant zero—

$$p = x + CX \frac{dx}{dt} \dots \dots \dots (i)$$

Since there is no current through the galvanometer, *p* = *q* and *r* = *s*, and since potential difference between *d* and *c* is equal to that between *d* and *a*—

$$L \frac{ds}{dt} + Ss = Qq = Qp \dots \dots \dots (ii)$$

¹ E. C. Rimington, *Phil. Mag.* (Ser. 5), 24, p. 54. 1887.

For a similar reason—

$$\begin{aligned} Xx + (P - X)p &= Rr = Rs \\ \therefore Xx - Xp + Pp &= Rs, \end{aligned}$$

and from (i)—

$$Xx - Xp = -CX^2 \frac{dx}{dt}$$

$$\therefore Pp - CX^2 \frac{dx}{dt} = Rs$$

and,

$$p = \frac{Rs}{P} + \frac{CX^2}{P} \cdot \frac{dx}{dt}.$$

Substituting for this in (ii)—

$$L \frac{ds}{dt} + Ss = \frac{QR}{P}s + \frac{QCX^2}{P} \cdot \frac{dx}{dt}$$

From the condition of steady balance we have—

$$S = \frac{QR}{P},$$

$$\therefore L \frac{ds}{dt} = \frac{QCX^2}{P} \cdot \frac{dx}{dt}$$

This is a condition which determines the ratio of the rates of growth of current in X and in R or S, whatever the actual rates of growth may be. It follows that the rates of growth of x and s are in a constant ratio when no current passes through the galvanometer, so that this condition is represented by the equation—

$$\frac{LP}{QCX^2} = \frac{dx}{ds}.$$

Integrating, we have—

$$x = \frac{LP}{QCX^2} s + \text{constant},$$

and if $x = 0$ when $s = 0$, the constant of integration is zero, so that—

$$\frac{LP}{QCX^2} = \frac{x}{s},$$

x and s being now steady currents.

When the currents are steady, those in the respective branches bad and bcd are in the inverse ratio of the resistances of these branches.

$$\therefore \frac{x}{s} = \frac{R + S}{P + Q} = \frac{R}{P} = \frac{S}{Q}.$$

$$\therefore \frac{LP}{QCX^2} = \frac{S}{Q}$$

or,

$$\frac{L}{C} = \frac{X^2 S}{P}.$$

(iii) Anderson.—A further modification of Maxwell's method is due to Prof. Anderson.¹ The balancing is performed as before, but the condenser is connected to B and to a point T (Fig. 318) between A and G, such that the resistance X of AT can be varied until there is no throw of the galvanometer on making or breaking the battery circuit.

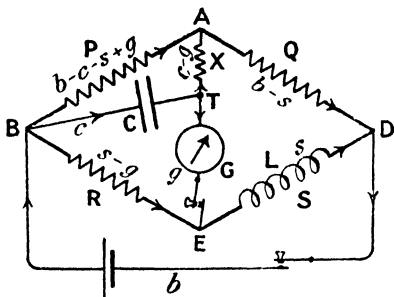

FIG. 318.

Let the instantaneous current in BT be c ; in G, g ; in S, s ; and in the battery, b . Then by Kirchhoff's first law (p. 69) the currents in the other branches are as shown in the diagram. Then, applying Kirchhoff's second law (p. 69) to the circuit BATEB,

$$P(b - c - s + g) - X(c - g) + Gg + p \frac{dg}{dt} - R(s - g) = 0$$

where p is the self-inductance of the galvanometer; and to the net BADEB,

$$P(b - c - s + g) + Q(b - s) - Ss - L \frac{ds}{dt} - R(s - g) = 0$$

Integrating these with respect to time, using as limits the instant when the battery circuit is closed, and that at which the currents in the branches become steady, and remembering that $g = 0$ in both cases,

$$P(b_0 - c_0 - s_0 + g_0) - X(c_0 - g_0) + Gg_0 - R(s_0 - g_0) = 0$$

and,

$$P(b_0 - c_0 - s_0 + g_0) + Q(b_0 - s_0) - Ss_0 - Ls - R(s_0 - g_0) = 0$$

where b_0 , c_0 , s_0 , and g_0 are the total quantities of charge that have passed through the respective circuits from first to last. Rearranging the terms in these equations, we have—

$$Pb_0 - (P + R)s_0 + (P + X + R + G)g_0 - (P + X)c_0 = 0 \quad (i)$$

$$(P + Q)b_0 - (P + Q + R + S)s_0 + (P + R)g_0 - Pc_0 - Ls = 0 \quad (ii)$$

Subtracting the first of these from the second—

$$Qb_0 - (Q + S)s_0 - (X + G)g_0 + Xc_0 - Ls = 0 \quad (iii)$$

Multiplying (i) through by Q , and (iii) by P and subtracting, the terms in b_0 disappear, as do those in s_0 since $Q(P + R) = P(Q + S)$ from the relation between the resistances for steady condition; that is—

$$\frac{P}{Q} = \frac{R}{S} = \frac{P + R}{Q + S}$$

¹ A. Anderson, *Phil. Mag.* (Ser. 5), 31, p. 329. 1891.

and we now have—

$$\{Q(P + X + R + G) + P(X + G)\}g_0 - \{Q(P + X) + PX\}c_0 + PLs = 0$$

$$\{Q(P + X + R + G) + P(X + G)\}g_0 = \{Q(P + X) + PX\}c_0 - PLs.$$

For the total charge passing through the galvanometer, that is g_0 , to be zero, the right-hand side of the last equation must be zero, so that—

$$PLs = c_0\{Q(P + X) + PX\}.$$

Now s and c_0 can be found from the steady conditions, for there is no current through the galvanometer, so that the current in BE is s ; and further, the difference of potential between the ends of the condenser is Rs , and the charge $c_0 = CRs$.

Hence, $PL = CR\{Q(P + X) + PX\}$

$$L = C \frac{R}{P} \{PQ + X(P + Q)\}$$

$$= C \left\{ RQ + X \frac{R(P + Q)}{P} \right\}$$

and since,

$$\frac{P}{R} = \frac{Q}{S} = \frac{P + Q}{R + S},$$

$$\therefore L = C\{RQ + X(R + S)\}.$$

Comparison of Mutual and Self-Inductance (Maxwell¹).—The

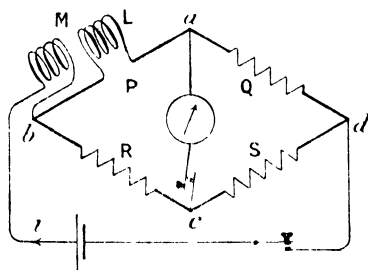

FIG. 319.

mutual inductance of a pair of coils may be found in terms of the inductance of one of them, by placing this coil in one arm of a Wheatstone's bridge, the other being in the battery circuit, care being taken that the one in the battery circuit is so connected that the electromotive force produced in L on account of it, when the current grows, is opposed to the self-inductance electromotive force in L itself.

Then, when the balance has been obtained for steady current,

$$\frac{P}{Q} = \frac{R}{S},$$

and when the current is growing, the difference of potential between b and a (Fig. 319) is—

$$L \frac{dp}{dt} - M \frac{di}{dt} + Pp.$$

¹ Maxwell, "Electricity and Magnetism," vol. ii.

This to be equal to the potential difference Rr , between b and c ,

$$\therefore L \frac{dp}{dt} - M \frac{di}{dt} + Pp = Rr.$$

Now $i = p + r$,

$$\therefore L \frac{dp}{dt} - M \frac{dp}{dt} - M \frac{dr}{dt} + Pp = Rr,$$

or, $(L - M) \frac{dp}{dt} - M \frac{dr}{dt} = Rr - Pp.$

But if there is no current in the galvanometer,

$$p = q, \text{ and } r = s,$$

therefore, for potential difference between d and a to be equal to that between d and c ,

$$\begin{aligned} Qp &= Sr \\ \text{and hence, } Q \frac{dp}{dt} &= S \frac{dr}{dt}. \end{aligned}$$

Substituting $\frac{Qp}{S}$ for r , and $Q \cdot \frac{dp}{dt}$ for $\frac{dr}{dt}$ in the above equation, we have—

$$(L - M) \frac{dp}{dt} - \frac{MQ}{S} \cdot \frac{dp}{dt} = \frac{QR}{S} p - Pp.$$

And remembering that $\frac{QR}{S} = P$, this reduces to, $L - M - \frac{MQ}{S} = 0$;

$$\begin{aligned} \therefore \frac{M}{L} &= \frac{S}{S + Q} \\ &= \frac{R}{P + R} \end{aligned}$$

Further methods of comparing inductances, capacities, and resistances will be described in the chapter on alternating currents.

Circuit with Inductance, Capacity, and Resistance (Charge).— We will now find how the current grows in a circuit to which a constant electromotive force e is applied, when the circuit has inductance and capacity as well as resistance. From the cases treated earlier (pp. 303 and 310) we see that the equation of instantaneous electromotive forces will contain four terms and will be,

$$l \frac{di}{dt} + ri + \frac{q}{c} = e,$$

where the letters have the meanings previously assigned to them.

Further, $i = \frac{dq}{dt}$, and the equation becomes—

$$l \frac{d^2q}{dt^2} + r \frac{dq}{dt} + \frac{q}{c} = e \quad (i)$$

It will therefore be necessary to solve this for q , afterwards obtaining the current by differentiating the value of q with respect to time.

For convenience we will write, $\frac{r}{l} = 2b$, and $\frac{1}{lc} = k^2$, so that—

$$\frac{d^2q}{dt^2} + 2b \frac{dq}{dt} + k^2q = \frac{e}{l}.$$

Let $x = q - \frac{e}{k^2}$, then

$$\frac{dx}{dt} = \frac{dq}{dt}, \quad \text{and,} \quad \frac{d^2x}{dt^2} = \frac{d^2q}{dt^2},$$

and substituting these values in the equation, we get—

$$\frac{d^2x}{dt^2} + 2b \frac{dx}{dt} + k^2x = 0,$$

which, being a homogeneous equation, may be solved in the form—

$$x = e^{at}.$$

From this we have—

$$\frac{dx}{dt} = ae^{at}$$

and,

$$\frac{d^2x}{dt^2} = a^2e^{at}$$

so that, substituting these values in the equation, we get—

$$a^2e^{at} + 2bae^{at} + k^2e^{at} = 0,$$

or,

$$a^2 + 2ba + k^2 = 0$$

that is,

$$a = -b \pm \sqrt{b^2 - k^2}$$

and there are two solutions—

$$x = A'e^{(-b + \sqrt{b^2 - k^2})t}, \quad \text{and,} \quad x = B'e^{(-b - \sqrt{b^2 - k^2})t}$$

where A' and B' are any arbitrary constants.

Now when two solutions such as—

$$x - A'\epsilon^{(-b + \sqrt{b^2 - k^2})t} = 0, \quad \text{and,} \quad x - B'\epsilon^{(-b - \sqrt{b^2 - k^2})t} = 0$$

have been found, it obviously follows that—

$$2x - A'\epsilon^{(-b + \sqrt{b^2 - k^2})t} - B'\epsilon^{(-b - \sqrt{b^2 - k^2})t} = 0,$$

or writing A for $\frac{A'}{2}$, and B for $\frac{B'}{2}$,

$$x = A\epsilon^{(-b + \sqrt{b^2 - k^2})t} + B\epsilon^{(-b - \sqrt{b^2 - k^2})t}$$

or, since $x = q - \frac{e}{k^2}$,

$$q = A\epsilon^{(-b + \sqrt{b^2 - k^2})t} + B\epsilon^{(-b - \sqrt{b^2 - k^2})t} + \frac{e}{k^2}.$$

Remembering that $k^2 = \frac{1}{lc}$, we see that the last term is equal to ec .

Whatever the nature of the variation of charge may be, we know that after a sufficiently long time has elapsed the charge will become steady and equal to ec (p. 149). Writing this final steady value of the charge equal to q_0 , our equation becomes—

$$q = A\epsilon^{(-b + \sqrt{b^2 - k^2})t} + B\epsilon^{(-b - \sqrt{b^2 - k^2})t} + q_0 \quad (ii)$$

This equation expresses the mode in which the charge q varies, but it does not give us definitely its value at any given time unless the arbitrary constants A and B are known. These may be determined if we know two conditions as regards charge, or rate of variation of charge, that is, current. Now, in the case considered, the electromotive force is suddenly applied to the circuit, and therefore the charge on the condenser at the instant of application is zero, the expression of which condition is that $q = 0$, when $t = 0$.

Equation (ii) then reduces to—

$$0 = A + B + q_0 \quad \text{or, } A + B = -q_0.$$

Further, the current is zero at the instant of applying the electromotive force, that is, $i = \frac{dq}{dt} = 0$, when $t = 0$.

Now, from equation (ii) —

$$i = \frac{dq}{dt} = (-b + \sqrt{b^2 - k^2}) A \epsilon^{(-b + \sqrt{b^2 - k^2})t} + (-b - \sqrt{b^2 - k^2}) B \epsilon^{(-b - \sqrt{b^2 - k^2})t}$$

$$\therefore 0 = (-b + \sqrt{b^2 - k^2}) A + (-b - \sqrt{b^2 - k^2}) B,$$

or, $-b(A + B) + \sqrt{b^2 - k^2}(A - B) = 0,$

But $A + B = -q_0$,

$$\therefore A - B = -\frac{q_0 b}{\sqrt{b^2 - k^2}}$$

and, $2A = -q_0 \left(1 + \frac{b}{\sqrt{b^2 - k^2}}\right), \quad 2B = -q_0 \left(1 - \frac{b}{\sqrt{b^2 - k^2}}\right).$

Putting these values of A and B in equation (ii) we get—

$$q = q_0 \left\{ 1 - \frac{1}{2} \left(1 + \frac{b}{\sqrt{b^2 - k^2}} \right) \epsilon^{(-b + \sqrt{b^2 - k^2})t} - \frac{1}{2} \left(1 - \frac{b}{\sqrt{b^2 - k^2}} \right) \epsilon^{(-b - \sqrt{b^2 - k^2})t} \right\} \quad (iii)$$

When $b^2 > k^2$, that is $\frac{r^2}{4l^2} > \frac{1}{lc}$, this equation for q cannot be further simplified, and the charge gradually acquires its final value q_0 . The mode of approach to q_0 is shown by the dotted curve in Fig. 320,

which is drawn for the case in which the inductance is 10 millihenrys, the capacity $\frac{1}{10}$ microfarad, and the resistance 1260 ohms.

$$\text{Thus,} \quad \frac{R^2}{4L^2} = 10^9.$$

$$\text{and,} \quad \frac{1}{LC} = 10^9,$$

so that, $b = 6.31 \times 10^4$, and $k = 3.16 \times 10^4$, and if the charging electromotive force be 10^7 volts, the final steady charge Q_0 is 1 coulomb.

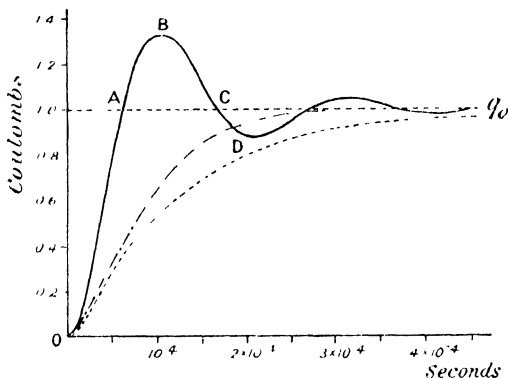

FIG. 320.

If, however, $b < k$ there is an entirely different state of affairs, for $b^2 - k^2$ is negative, and $\sqrt{b^2 - k^2}$ is an imaginary quantity. Let it be written, $\sqrt{-1} \sqrt{k^2 - b^2}$, or $j\sqrt{k^2 - b^2}$, where $j = \sqrt{-1}$, so that the quantity under the root sign is again real. Equation (iii) thus becomes—

$$q = q_0 \left\{ 1 - \epsilon^{-bt} \left(\frac{\epsilon^{j\sqrt{k^2 - b^2}t} + \epsilon^{-j\sqrt{k^2 - b^2}t}}{2} + \frac{b}{\sqrt{k^2 - b^2}} \frac{\epsilon^{j\sqrt{k^2 - b^2}t} - \epsilon^{-j\sqrt{k^2 - b^2}t}}{2j} \right) \right\}$$

Now the exponential form of $\cos \sqrt{k^2 - b^2}t$ is $\frac{\epsilon^{j\sqrt{k^2 - b^2}t} + \epsilon^{-j\sqrt{k^2 - b^2}t}}{2}$

and of $\sin \sqrt{k^2 - b^2}t$ is $\frac{\epsilon^{j\sqrt{k^2 - b^2}t} - \epsilon^{-j\sqrt{k^2 - b^2}t}}{2j}$ (see p. 377), and substituting these values in our equation we have—

$$q = q_0 \left\{ 1 - \frac{\epsilon^{-bt}}{\sqrt{k^2 - b^2}} (\sqrt{k^2 - b^2} \cos \sqrt{k^2 - b^2}t + b \sin \sqrt{k^2 - b^2}t) \right\}.$$

Taking an angle θ , such that—

$$\tan \theta = \frac{b}{\sqrt{k^2 - b^2}}, \quad \sin \theta = \frac{b}{k}, \quad \text{and} \quad \cos \theta = \frac{\sqrt{k^2 - b^2}}{k},$$

$$q = q_0 \left\{ 1 - \frac{k\epsilon^{-bt}}{\sqrt{k^2 - b^2}} \left(\cos \theta \cos \sqrt{k^2 - b^2}t + \sin \theta \sin \sqrt{k^2 - b^2}t \right) \right\}$$

$$= q_0 \left\{ 1 - \frac{k\epsilon^{-bt}}{\sqrt{k^2 - b^2}} \cos \left(\sqrt{k^2 - b^2}t - \theta \right) \right\} \dots \dots \dots \text{(iv)}$$

The full curve OABCD, etc. (Fig. 320), is obtained from this equation, for the case in which $L = 10$ millihenrys = 10^{-2} henrys, $C = \frac{1}{10}$ microfarad = 10^{-7} farad, and $R = 200$ ohms, the charging electromotive force being 10^7 volts, so that $Q_0 = EC = 1$ coulomb.

$$b^2 = \left(\frac{200}{2 \times 10^{-2}} \right)^2 = 10^8, \quad \text{and} \quad k^2 = \frac{1}{10^{-2} \times 10^{-7}} = 10^9.$$

In this case the discharge is oscillatory, being alternately greater and less than Q_0 before settling down to this steady value, and with the given quantities it will be seen that after passing the value Q_0 four times, the amplitude of the oscillation is reduced to about $\frac{1}{40}$ of its original value.

The diminution in amplitude is due to the term ϵ^{-bt} , or $\epsilon^{-\frac{R}{2L}t}$, and with a less resistance than that chosen, this term would become of less importance and the damping of the oscillations less rapid; in the limiting case when $R = 0$ the term $\epsilon^{-\frac{R}{2L}t}$ would equal unity, and the charge upon the condenser would vary in a simple harmonic manner.

It will be seen that the value of the charge for the point B upon the curve, that is after one half-oscillation, is much greater than its final steady value. This explains the fact that on connecting a condenser to an electrical supply, when the inductance in the circuit is large and the resistance small, the potential difference between the plates momentarily attains nearly twice the final steady value, and the insulation of the condenser may break down, although sufficiently strong to stand the final steady potential difference. The breaking down may be prevented by putting in circuit at the moment of connection, a resistance which may subsequently be removed, but which has the effect of damping out the violent oscillations that would otherwise occur.

Current.—The *current* in the circuit at any instant may be derived from equation (iv); thus—

$$i = \frac{dq}{dt} = q_0 k \epsilon^{-bt} \sin \left(\sqrt{k^2 - b^2}t - \theta \right) + q_0 \frac{k b \epsilon^{-bt}}{\sqrt{k^2 - b^2}} \cos \left(\sqrt{k^2 - b^2}t - \theta \right)$$

$$= \frac{q_0 k \epsilon^{-bt}}{\sqrt{k^2 - b^2}} \left\{ \sqrt{k^2 - b^2} \sin \left(\sqrt{k^2 - b^2}t - \theta \right) + b \cos \left(\sqrt{k^2 - b^2}t - \theta \right) \right\}.$$

Remembering that $\tan \theta = \frac{b}{\sqrt{k^2 - b^2}}$, etc., we see that this equation becomes—

$$i = \frac{q_0 k^2 \epsilon^{-bt}}{\sqrt{k^2 - b^2}} \sin \sqrt{k^2 - b^2} t \dots \dots \dots \quad (\text{v})$$

Frequency of Oscillation.—In the case of the current, we see from equation (v) that at times 0, $\frac{\pi}{\sqrt{k^2 - b^2}}$, $\frac{2\pi}{\sqrt{k^2 - b^2}}$, etc., the value is zero, and from equation (iv) that after intervals from the start, of $\frac{\theta + \frac{\pi}{2}}{\sqrt{k^2 - b^2}}$, $\frac{\theta + \frac{3\pi}{2}}{\sqrt{k^2 - b^2}}$, etc., the value of q is equal to q_0 . In either case $\frac{\pi}{\sqrt{k^2 - b^2}}$ represents the time for half an oscillation, so that the time for a complete oscillation, or the periodic time, is—

$$\frac{2\pi}{\sqrt{k^2 - b^2}} = \frac{2\pi}{\sqrt{\frac{1}{LC} - \frac{R^2}{4L^2}}}$$

When R is small, this approximates to $2\pi\sqrt{LC}$, and in most practical cases the value of R is not great enough to cause the periodic time to differ greatly from this value.

The frequency is given by—

$$N = \frac{1}{T} = \frac{\sqrt{\frac{1}{LC} - \frac{R^2}{4L^2}}}{2\pi}$$

or when R is small—

$$N = \frac{1}{2\pi\sqrt{LC}}$$

In the example given on p. 334, $\frac{1}{LC} = 10^9$ and $\frac{R^2}{4L^2} = 10^8$, so that—

$$N = \frac{\sqrt{10^9 - 10^8}}{2\pi} = 4776 \text{ oscillations per second.}$$

Limiting Case.—Equation (iii) evidently breaks down when $b = k$, for in this case two of the coefficients become infinite. Returning to equation (ii) let us see what form this takes when $\sqrt{b^2 - k^2}$ has not vanished but is reduced to some very small quantity h .

$$\begin{aligned} \text{Then,} \quad q &= A\epsilon^{(-b+h)t} + B\epsilon^{(-b-h)t} + q_0 \\ &= \epsilon^{-bt}(A\epsilon^{ht} + B\epsilon^{-ht}) + q_0 \end{aligned}$$

Writing ϵ^{ht} and ϵ^{-ht} in the form of series—

$$\epsilon^{ht} = 1 + ht + \frac{h^2 t^2}{2} + \frac{h^3 t^3}{3} + \dots$$

$$\epsilon^{-ht} = 1 - ht + \frac{h^2 t^2}{2} - \frac{h^3 t^3}{3} + \dots$$

$$q = \epsilon^{-bt} \left\{ A \left(1 + ht + \frac{h^2 t^2}{2} + \dots \right) + B \left(1 - ht + \frac{h^2 t^2}{2} - \dots \right) \right\} + q_0$$

Now, h being very small, the terms in h^2 and higher powers may be neglected; but the quantities Ah and Bh have unknown magnitudes since A and B are unknown.

Thus, $q = \epsilon^{-bt} \{ (A + B) + (A - B)ht \} + q_0$

Calling these two constants $(A + B)$ and $(A - B)h$, G and H respectively—

$$q = \epsilon^{-bt} (G + Ht) + q_0$$

This is a solution of equation (i), as may be shown by differentiation and substitution of q , $\frac{dq}{dt}$ and $\frac{d^2q}{dt^2}$ in (i); it represents the limiting case when $\sqrt{b^2 - k^2}$ approaches the value 0.

Now let $q = 0$, when $t = 0$, and we have $G = -q_0$.

Again, let, $\dot{q} = \frac{dq}{dt} = 0$, when $t = 0$

$$\frac{dq}{dt} = -b\epsilon^{-bt} (G + Ht) + H\epsilon^{-bt}$$

$$0 = -bG + H, \text{ or, } H = -bq_0$$

$$\therefore q = q_0 \{ 1 - \epsilon^{-bt} (1 + bt) \}$$

The curve representing this equation is shown by the chain line in Fig. 320. In this case $L = 10^{-2}$ henrys, $C = 10^{-7}$ farads, and $R = 2 \times 10^3$ ohms = 632.4 ohms, so that—

$$k^2 = \frac{1}{LC} = 10^9, \quad b^2 = \frac{R^2}{4L^2} = \frac{4 \times 10^6}{4 \times 10^{-4}} = 10^9.$$

Discharge.—To find the manner in which the condenser discharges on suddenly removing the external source of electromotive force, we put $e = 0$ in equation (i) on p. 331, which then becomes—

$$l \frac{d^2q}{dt^2} + r \frac{dq}{dt} + \frac{q}{c} = 0 \quad \dots \dots \dots (vi)$$

or, $\frac{d^2q}{dt^2} + 2b \frac{dq}{dt} + k^2q = 0,$

where, as before, $b = \frac{r}{2l}$ and $k^2 = \frac{1}{lc}$.

This is of the same form as the equation in x on p. 332, and, as there explained, the solution is—

$$q = A\epsilon^{(-b + \sqrt{b^2 - k^2})t} + B\epsilon^{(-b - \sqrt{b^2 - k^2})t} \dots \text{(vii)}$$

Putting in the limiting conditions we have, since $q = q_0$ when $t = 0$,

$$A + B = q_0$$

and since $\frac{dq}{dt} = 0$, when $t = 0$ —

$$(-b + \sqrt{b^2 - k^2})A + (-b - \sqrt{b^2 - k^2})B = 0.$$

Solving these two equations for A and B and substituting their values in (vii)—

$$q = q_0 \left\{ \frac{1}{2} \left(1 + \frac{b}{\sqrt{b^2 - k^2}} \right) \epsilon^{(-b + \sqrt{b^2 - k^2})t} + \frac{1}{2} \left(1 - \frac{b}{\sqrt{b^2 - k^2}} \right) \epsilon^{(-b - \sqrt{b^2 - k^2})t} \right\} \text{(viii)}$$

When $b > k$ this equation represents the dead beat discharge, the dotted curve in Fig. 321 being drawn for the case given on p. 334.

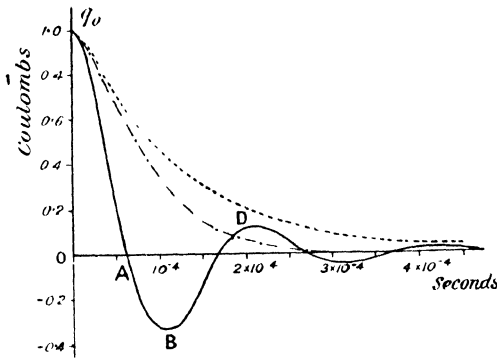

FIG. 321.

When $b < k$ the equation is transformed as on p. 334, into the form—

$$q = q_0 \epsilon^{-bt} \left\{ \frac{\epsilon^{j\sqrt{k^2 - b^2}t} + \epsilon^{-j\sqrt{k^2 - b^2}t}}{2} + \frac{b}{\sqrt{k^2 - b^2}} \frac{\epsilon^{j\sqrt{k^2 - b^2}t} - \epsilon^{-j\sqrt{k^2 - b^2}t}}{2j} \right\}$$

or,

$$q = q_0 \epsilon^{-bt} \left\{ \cos \sqrt{k^2 - b^2}t + \frac{b}{\sqrt{k^2 - b^2}} \sin \sqrt{k^2 - b^2}t \right\}$$

$$= \frac{q_0 k \epsilon^{-bt}}{\sqrt{k^2 - b^2}} \cos (\sqrt{k^2 - b^2}t - \theta) \dots \dots \dots \text{(ix)}$$

where $\tan \theta = \frac{b}{\sqrt{k^2 - b^2}}$ etc.

The discharge is therefore oscillatory when $k > b$, and the curve q_0ABD in Fig. 321 shows the form of the discharge in the given case. At B the charge upon the condenser has the reverse sign to that of q_0 . The points where the curve cuts the axis are separated by an interval of time $\frac{\pi}{\sqrt{k^2 - b^2}}$ or $\frac{\pi}{\sqrt{\frac{1}{LC} - \frac{R^2}{4L^2}}}$, which is therefore half

the periodic time.

The oscillatory character of the discharge of a condenser when the inductance in the circuit is sufficiently great for the condition $\frac{R^2}{4L^2} < \frac{1}{LC}$ to be fulfilled, was first pointed out by Lord Kelvin in 1853.¹

In the event of R being inappreciable, $b = 0$, and the equation for the discharge becomes—

$$Q = Q_0 \cos \frac{t}{\sqrt{LC}},$$

and the oscillations are harmonic, the charge surging backwards and forwards through the inductance, being alternately positive and negative upon either plate of the condenser. For either extreme, the energy of the charge is $\frac{1}{2} \frac{Q_0^2}{C}$, and at an instant halfway between these extremes, the charge upon the condenser is zero, and the energy is associated with the inductance and has the value $\frac{1}{2} LI^2$ joules (see p. 302).

Since—

$$I = \frac{dQ}{dt} = -\frac{1}{\sqrt{LC}} Q_0 \sin \frac{t}{\sqrt{LC}},$$

the greatest value of this occurs when—

$$\frac{t}{\sqrt{LC}} = \frac{\pi}{2}, \text{ and, } \sin \frac{t}{\sqrt{LC}} = 1.$$

Hence at this instant, $I = -\frac{Q_0}{\sqrt{LC}}$

and the energy, $\frac{1}{2} LI^2 = \frac{1}{2} L \cdot \frac{Q_0^2}{LC} = \frac{1}{2} \frac{Q_0^2}{C}$

Thus the energy alternates between the statical and the dynamical form, and is associated first with the capacity and then with the inductance, being reversed twice at every oscillation.

¹ W. Thompson, *Phil. Mag.* (Ser. 4), 5, p. 398. 1853.

When R is not zero, there is a continual dissipation of electrical energy into heat as the current flows in the resistance, and since this process is not reversible, the energy of the charge gets less and less at each oscillation and finally vanishes. It is also possible that some of the energy is radiated into space at each oscillation, but a discussion of this will be reserved to a later chapter.

Limiting Conditions.—The distinction between the dead beat form of discharge, in which the sign of the charge is not reversed ($b > k$), and the oscillatory form ($b < k$), although very much in evidence in the mathematical form in which the discharge is represented, is not really very marked, for as k gets nearer and nearer in value to b , the oscillations become so rapidly damped that the discharge is almost exponential in type. In fact there is no discontinuity in passing from one form of the discharge to the other, as the student may see if he will plot several curves resembling those in Fig. 321, for values of k approaching very near to that of b .

As before, equation (viii) breaks down when $b = k$, and we obtain our solution by putting $\sqrt{b^2 - k^2} = h$, and finding the form of the solution when h is extremely small. On p. 338 we saw that the exponential terms take the form $\epsilon^{-bt}(G + Ht)$, and therefore—

$$q = \epsilon^{-bt}(G + Ht)$$

If now, $q = q_0$, when $t = 0$, $G = q_0$; and if $\frac{dq}{dt} = 0$, when $t = 0$, $H = bq_0$,

$$\therefore q = q_0 \epsilon^{-bt}(1 + bt).$$

The chain curve in Fig. 321 represents this equation in the given case.

Rate of Discharge.—When b is very small in comparison with k , the oscillations are nearly simple harmonic, and die away very slowly; and on the other hand, when b is very large in comparison with k , the discharge is dead beat, the steady state being reached only after the lapse of considerable time. Thus when b is very small or very large with respect to k , the process of discharge takes considerable time for its completion. This consideration, together with an examination of Fig. 321, will lead us to the conclusion that the final state of complete discharge is reached more rapidly as b approaches in value to k .

From equation (ix) (p. 338) we see that the term $\cos(\sqrt{k^2 - b^2}t - \theta)$ has alternately values $+1$ and -1 , the values $+1$ occurring at times differing by intervals $\frac{2\pi}{\sqrt{k^2 - b^2}}$; hence the maxima occur at times

differing by these intervals, and have values $q \propto q_0 \epsilon^{-\frac{2\pi nb}{\sqrt{k^2 - b^2}}}$, where n has the successive values, 0, 1, 2, 3, etc. Remembering that for the oscillatory discharge, $b < k$, we see that these successive maxima

decrease most rapidly as b increases, since $\frac{b}{\sqrt{k^2 - b^2}}$ becomes greater. We have the maximum rate of damping out of the vibrations when $b = k$, since in this limiting condition—

$$\frac{b}{\sqrt{k^2 - b^2}} = \infty.$$

Returning to equation (vii) (p. 338) we see that for the dead beat discharge, that is, when $b > k$; the second term diminishes extremely rapidly since $-b - \sqrt{k^2 - b^2}$ is always numerically large. The first term is therefore much the more important, and the greater the numerical value of the term $-b + \sqrt{b^2 - k^2}$, which is always negative, the more rapidly does the charge decay. Thus, as $b - \sqrt{b^2 - k^2}$ increases the decay becomes more rapid. To find how $b - \sqrt{b^2 - k^2}$ varies as b approaches k in value, write—

$$y = b - \sqrt{b^2 - k^2}$$

$$\frac{dy}{db} = 1 - \frac{b}{\sqrt{b^2 - k^2}},$$

and as b approaches in value to k , $\frac{dy}{db}$ is evidently negative, that is, as b diminishes $b - \sqrt{b^2 - k^2}$ increases, and therefore as b diminishes the rate of decay increases. This holds up to the limiting case when $b = k$, and we therefore see that as we approach from the oscillatory side or the dead beat side, towards the limiting case, the rate of discharge becomes more rapid. Hence the limiting case when $b = k$ is that in which the charge most quickly disappears.

This was first pointed out by Dr. Sumpner¹ and is of particular importance in the design of galvanometers. There is complete analogy between the motion of a galvanometer needle and that of a discharging condenser (see p. 258). With no damping, the swings last a great time, as in the case of the ballistic galvanometer. On the other hand, if the damping is too great the motion is dead beat, and the final position of the needle is taken up too slowly. This is extremely troublesome as it renders the galvanometer very sluggish. The best working conditions for ordinary use are obtained when the needle comes very quickly to rest after very few oscillations, a condition sometimes, although wrongly, called dead beat.

Discharge examined by Rotating Mirror.—The change in character of the discharge from dead beat to oscillatory, as the resistance of the circuit is reduced, may be seen by examining the spark by means of a rotating mirror. The condenser is charged by means of the induction coil, the spark discharge taking place between the terminals P

¹ W. E. Sumpner, *Phil. Mag.* (Ser. 5), 25, p. 453. 1888.

(Fig. 322) once at every break of the primary circuit. The circuit ACBP in which the oscillations occur, has usually sufficient inductance for the purpose, but if necessary this may be increased by including a few turns of wire. When the points P are far apart, the image of the spark seen in the rotating mirror consists of one thin band for each

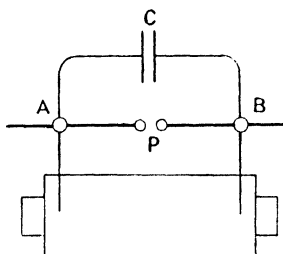

FIG. 322.

discharge, but on approaching the points until the resistance falls below the critical value, a group of lines which may extend to 6 or 7 in number, is seen at each discharge, which is consequently oscillatory.

The production of oscillations will be further considered in the chapter on radiation.

CHAPTER XII

ALTERNATING CURRENTS

THE development of dynamo-electric machinery, in which a coil or system of coils is rotated in, or moves through, a magnetic field, giving rise to alternating electromotive forces, and of the transformer which enables the energy produced to be changed from small current at high voltage to large current at low voltage and *vice versa*, has rendered a study of the current produced by an electromotive force which varies harmonically, of great importance. A still further importance to this study arises from the employment of oscillating currents, the commercial application of which is realised in the various systems of wireless telegraphy.

Circuit with Inductance and Resistance.—For many purposes, the capacity in the circuit is relatively unimportant, and we will first consider the simple case in which a harmonic electromotive force, $E_0 \sin pt$, is applied to a circuit having resistance and inductance only, the effect of including capacity as well, being left until later.

The equation of electromotive forces for such a circuit has been given on p. 303. It is—

$$L \frac{dI}{dt} + RI = E.$$

Replacing E by the value $E_0 \sin pt$, we have—

$$L \frac{dI}{dt} + RI = E_0 \sin pt,$$

E_0 being the maximum electromotive force, and $\frac{2\pi}{p}$ the periodic time of alternation.

A pure sine electromotive force, that is, one which varies in a simple harmonic manner, may be produced by rotating a coil with constant angular velocity in a uniform magnetic field. For, if N be the magnetic flux linked with the coil when its plane is perpendicular to the field (Fig. 258), $N \sin \theta$ is the flux when the plane of the coil makes angle θ with the field.

$$\begin{aligned}
 \text{Then,} \quad E &= -\frac{d(N \sin \theta)}{dt} \\
 &= -N \frac{d(\sin \theta)}{dt} \\
 &= -N \cos \theta \cdot \frac{d\theta}{dt}.
 \end{aligned}$$

But if the angular velocity $\frac{d\theta}{dt} = p$, then, $d\theta = p dt$, or $\theta = pt + \frac{\pi}{2}$, the constant of integration being $\frac{\pi}{2}$, if time is reckoned from the instant at which $\theta = -\frac{\pi}{2}$.

$$\begin{aligned}
 \text{Then,} \quad E &= -pN \cos \left(pt + \frac{\pi}{2} \right) \\
 &= pN \sin pt \\
 &= E_0 \sin pt.
 \end{aligned}$$

The electromotive force produced by an alternating current dynamo is not usually of this simple type, but is of the form—

$$E_0 \sin pt + E_1 \sin 3pt + E_2 \sin 5pt + \dots,$$

but we shall only deal with the case in which the first term alone is present, this one being always by far the most important.

The only part of the solution of our equation which is of importance to us, is that in which the current has the same periodicity as the electromotive force, any other being quickly damped out. The current after a very short time takes the form, $I = A \sin pt + B \cos pt$, which is the most general form of a simple harmonic current of periodic time $\frac{2\pi}{p}$. A and B are constants to be determined from the conditions of the problem. To find them, differentiate I with respect to t , and substitute for I and $\frac{dI}{dt}$ in the original equation.

$$\text{Thus,} \quad \frac{dI}{dt} = pA \cos pt - pB \sin pt,$$

and substituting in the equation on p. 343, we have—

$$LpA \cos pt - LpB \sin pt + RA \sin pt + RB \cos pt = E_0 \sin pt.$$

This must be true for all values of t .

$$\begin{aligned}
 \text{When,} \quad t &= 0, \quad \sin pt = 0, \quad \text{and} \quad \cos pt = 1. \\
 \therefore LpA + RB &= 0.
 \end{aligned}$$

$$\begin{aligned}
 \text{When,} \quad pt &= \frac{\pi}{2}, \quad \sin pt = 1, \quad \text{and} \quad \cos pt = 0. \\
 \therefore RA - LpB &= E_0.
 \end{aligned}$$

Solving these two simultaneous equations for A and B, we got—

$$A = \frac{RE_0}{L^2p^2 + R^2}, \text{ and, } B = -\frac{LpE_0}{L^2p^2 + R^2}.$$

Hence,
$$I = \frac{E_0}{L^2p^2 + R^2} (R \sin pt - Lp \cos pt).$$

This may be thrown into a more convenient form by writing $\cos \theta$ for $\frac{R}{\sqrt{L^2p^2 + R^2}}$, whence—

$$\frac{Lp}{\sqrt{L^2p^2 + R^2}} = \sin \theta, \text{ and, } \frac{Lp}{R} = \tan \theta.$$

$$\therefore I = \frac{E_0}{\sqrt{L^2p^2 + R^2}} (\sin pt \cos \theta - \cos pt \sin \theta),$$

$$I = \frac{E_0}{\sqrt{L^2p^2 + R^2}} \sin (pt - \theta).$$

We therefore see that the current has amplitude $\frac{E_0}{\sqrt{L^2p^2 + R^2}} = I_0$ and lags in phase behind the electromotive force by an angle

$$\theta = \tan^{-1} \frac{Lp}{R}.$$

In the special case in which $L = 0$ —

$$I = \frac{E_0 \sin pt}{R} = \frac{E}{R}.$$

The current is then in phase with the electromotive force, and its value at every instant is given by the ordinary ohmic relation.

Vector Diagram.—The behaviour of a circuit to which an alternating electromotive force is applied, may conveniently be represented by a vector diagram of electromotive forces, and by means of such a diagram the current may be plotted in the form of a curve. Thus if OA in Fig. 323 (i) represents to scale the value of E_0 , then the projection of this on the axis of y at the instant t , is $E_0 \sin pt$ and is equal to E , the instantaneous value of the electromotive force. On constructing the right-angled triangle AOB with angle $AOB = \theta = \tan^{-1} \frac{Lp}{R}$,

$$OB = E_0 \cos \theta = \frac{RE_0}{\sqrt{L^2p^2 + R^2}} = RI_0$$

and OD, the projection of OB upon the axis of y , is—

$$\frac{RE_0}{\sqrt{L^2p^2 + R^2}} \sin (pt - \theta) = RI_0 \sin (pt - \theta) = RI,$$

and is the instantaneous value of that component of the applied electromotive force that is used in driving the current in opposition to the ohmic resistance of the circuit.

Again, since $DE = OE - OD = E - RI$, and $L \frac{di}{dt} = E - RI$, we see that DE represents the component of the electromotive force that

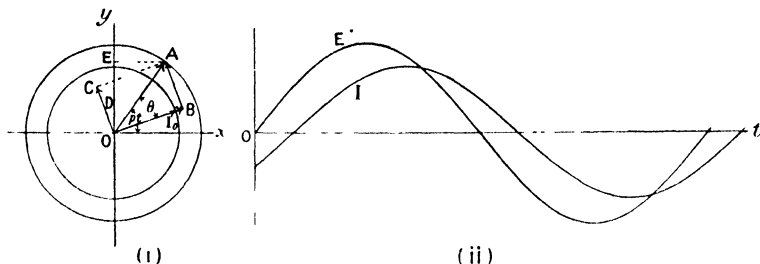

FIG. 323.

is due to the inductance of the circuit, and is the projection of BA upon the axis of y . But $BA = OA \sin \theta = \frac{I_0 p E_0}{\sqrt{L^2 p^2 + R^2}} = I_0 p I_0$. BA is at right angles to OB , and the electromotive force due to inductance is therefore 90° in phase ahead of the current.

This might also have been obtained from the relation—

$$I = I_0 \sin (pt - \theta),$$

for,

$$\frac{dI}{dt} = p I_0 \cos (pt - \theta) = p I_0 \sin (pt - \theta + 90^\circ)$$

$$\therefore L \frac{dI}{dt} = L p I_0 \sin (pt - \theta + 90^\circ)$$

The vector OC may be drawn parallel and equal to BA , and we see that the angle $\angle xOC = pt - \theta + 90^\circ$, and electromotive force OA is resultant of OB and OC . As the three rotate with constant angular velocity p , their projections on the axis of y represent the instantaneous values of the applied electromotive force and its components. The current being in phase with OB , it may be represented by a vector $OI_0 = \frac{OB}{R}$, and by taking an axis of time parallel to Ox we may, by making the ordinates equal to OE and to the projection of OI_0 , draw the curves of electromotive force (E) and current (I) in Fig. 323 (ii).

Impedance and Reactance.—The quantity $\sqrt{L^2 p^2 + R^2}$ plays a similar part in the consideration of alternating currents, to resistance in continuous currents, for $I_0 = \frac{E_0}{\sqrt{L^2 p^2 + R^2}}$. It is called the *Imped-*

ance of the circuit. If either L or p becomes zero, the impedance reduces to R , the resistance. The greater the value of Lp , the more does the impedance differ from the resistance, and when the periodicity n (that is $\frac{p}{2\pi}$) becomes so great that the resistance is relatively unimportant, the impedance becomes Lp . This quantity is called the *Reactance* of the circuit, and thus the impedance has for its limiting values the resistance, for very low frequency, and the reactance, for very high frequency.

Measuring Instruments.—An ordinary electromagnetic ammeter or voltmeter whose moving parts are comparatively massive, will indicate the mean value of the quantity to be measured, when this varies rapidly. The mean value of the quantity $E_0 \sin a$ for a complete cycle, where a is written for simplicity instead of pt , is—

$$\frac{\int_0^{2\pi} E_0 \sin a \, da}{\int_0^{2\pi} da} = -\frac{E_0}{2\pi} [\cos a]_0^{2\pi} = 0,$$

and therefore the reading of an electromagnetic voltmeter on an alternating supply will be zero. The reason is, that for the first half of a cycle, the mean value is $\frac{1}{\pi} \int_0^{\pi} E_0 \sin a \, da = -\frac{E_0}{\pi} [\cos a]_0^{\pi} = \frac{2E_0}{\pi}$, and for the second half, $\frac{1}{\pi} \int_{\pi}^{2\pi} E_0 \sin a \, da = -\frac{2E_0}{\pi}$. Thus the mean values are alternately positive and negative, and the suspended needle or coil will receive equal and opposite impulses during a complete cycle. For this reason it is necessary to employ instruments whose deflections are all in one direction, whatever the direction of the electromotive force or current. This is the case when the deflection depends upon the square of the electromotive force or current, as in the case of the hot-wire voltmeter or ammeter, the heating produced by the current in a fine wire causing its expansion, which the instrument indicates. Also the electrometer used idiosstatically (see p. 159) may be used for the measurement of alternating electromotive forces; or certain soft-iron ammeters (p. 88) in the case of current.

In order to interpret the readings of such an instrument, let us find the mean value of $I_0^2 \sin^2 a$, or $E_0^2 \sin^2 a$, for it is this mean value that is proportional to the indication of the instrument; that is, we

must find the value of the quantity,
$$\frac{\int_0^{2\pi} I_0^2 \sin^2 a \, da}{\int_0^{2\pi} da}.$$

Now,
$$\int_0^{2\pi} da = 2\pi.$$

$$\begin{aligned}
 \text{and,} \quad \int_0^{2\pi} I_0^2 \sin^2 a \, da &= I_0^2 \int_0^{2\pi} \frac{1 - \cos 2a}{2} \, da \\
 &= I_0^2 \left[\frac{a}{2} - \frac{\sin 2a}{4} \right]_0^{2\pi} \\
 &= \pi I_0^2. \\
 \therefore \text{mean value} &= \frac{\pi I_0^2}{2\pi} = \frac{I_0^2}{2}.
 \end{aligned}$$

Virtual Current and E.M.F.—The same value of the mean would have been obtained if we had taken half the cycle instead of the whole, since the square of any quantity is positive, and the sign of $I_0^2 \sin^2 a$ does not change during the cycle. In Fig. 324 the values of I and I^2

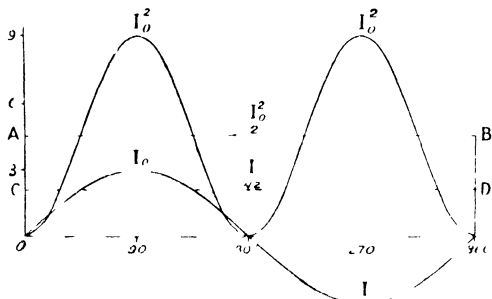

FIG. 324.

are plotted, when $I_0 = 3$. The line AB has the same mean ordinate as the curve I^2 . The continuous current represented by CD, whose square would have the same mean value as that of the alternating current is therefore $\frac{I_0}{\sqrt{2}}$ and would give the same reading on a hot-wire ammeter. This is called the *virtual current*, and is equivalent to the alternating current whose maximum value is I_0 . Thus if I_0 is measured in amperes, $\frac{I_0}{\sqrt{2}}$ is the equivalent current measured in virtual amperes.

In a similar way $\frac{E_0}{\sqrt{2}}$ is the virtual voltage of an alternating current whose maximum voltage is E_0 .

The advantage of measuring electromotive force in virtual volts, and current in virtual amperes, is that a suitable instrument may be calibrated by means of a continuous electromotive force or current, and will then read virtual volts or amperes on an alternating current supply.

Measurement of Inductance.—When a source of alternating electromotive force is available, the self-inductance of a coil may be found by measuring the electromotive force and current, first using a direct, and then an alternating current. The first readings give the resistance R of the coil. The second pair of readings give $\frac{I_0}{\sqrt{2}}$ and $\frac{E_0}{\sqrt{2}}$.

But,

$$\frac{I_0}{\sqrt{2}} = \frac{E_0}{\sqrt{2}\sqrt{L^2p^2 + R^2}}$$

$$\therefore L^2p^2 + R^2 = \frac{E_0^2}{I_0^2} = \frac{E_{\sim}^2}{I_{\sim}^2},$$

where E_{\sim} and I_{\sim} are the virtual volts and amperes.

If the frequency of alternation is n_{\sim} ,

$$n_{\sim} = \frac{p}{2\pi}, \quad \therefore p = 2\pi n_{\sim},$$

and L may then be calculated.

This method has the advantage that when the circuit encloses iron, and the inductance is therefore variable, the value obtained is that for the particular value of I_{\sim} employed, and this may be chosen to be the value at which the coil is eventually to be used.

Power in Alternating Current Circuit.—In the case of a non-inductive circuit, $I = \frac{E_0}{R} \sin pt = I_0 \sin pt$, when $E = E_0 \sin pt$. The rate of working at any instant is therefore $EI = E_0I_0 \sin^2 pt$ watts.

We have seen (p. 348) that the mean value of $\sin^2 pt$ for a cycle is equal to $\frac{1}{2}$, and therefore—

$$\begin{aligned} \text{mean rate of working} &= \frac{1}{2}E_0I_0 \text{ watts} \\ &= \frac{E_0}{\sqrt{2}} \cdot \frac{I_0}{\sqrt{2}} \text{ watts.} \end{aligned}$$

Now $\frac{E_0}{\sqrt{2}}$ is the virtual voltage, and $\frac{I_0}{\sqrt{2}}$ the virtual current, therefore mean rate of working in watts is the product, (virtual volts) \times (virtual amperes).

In the case of an inductive circuit—

$$\begin{aligned} E &= E_0 \sin pt, \\ I &= I_0 \sin (pt - \theta). \end{aligned}$$

Therefore the instantaneous rate of working is—

$$\begin{aligned} EI &= E_0I_0 \sin pt \sin (pt - \theta) \\ &= E_0I_0 \sin pt (\sin pt \cos \theta - \cos pt \sin \theta) \\ &= E_0I_0 \sin^2 pt \cos \theta - \frac{1}{2}E_0I_0 \sin 2pt \sin \theta. \end{aligned}$$

The mean value for a cycle is $\frac{1}{2}$ in the case of $\sin^2 pt$, and zero for $\sin 2pt$.

$$\begin{aligned} \therefore \text{mean rate of working} &= \frac{1}{2} E_0 I_0 \cos \theta \text{ watts} \\ &= (\text{virtual volts})(\text{virtual amperes}) \times \cos \theta. \end{aligned}$$

The following method brings us to the same result, and throws additional light upon the processes going on.

Let the vector E_0 (Fig. 325) represent the maximum electromotive force, and I_0 the maximum current. Resolving I_0 along and at right angles to E_0 , we get the component $I_0 \cos \theta$ in phase with the electromotive force, giving us the mean rate of working $\frac{1}{2} E_0 I_0 \cos \theta$, and the component $I_0 \sin \theta$, lagging 90° in phase behind the electromotive force, and giving us a mean rate of working

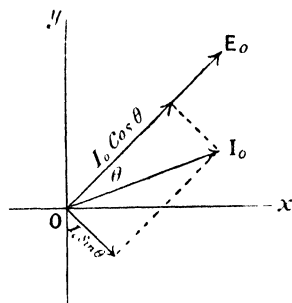

FIG. 325.

$$\begin{aligned} &\frac{1}{2\pi} \int_0^{2\pi} E_0 I_0 \sin a \sin(a - 90^\circ) da, \text{ that is—} \\ &-\frac{E_0 I_0}{2\pi} \int_0^{2\pi} \sin a \cos a da \\ &= \frac{E_0 I_0}{8\pi} [\cos 2a]_0^{2\pi} = 0. \end{aligned}$$

This latter component is called *Idle* or *Wattless* current since its presence does not contribute to the rate at which work is being done

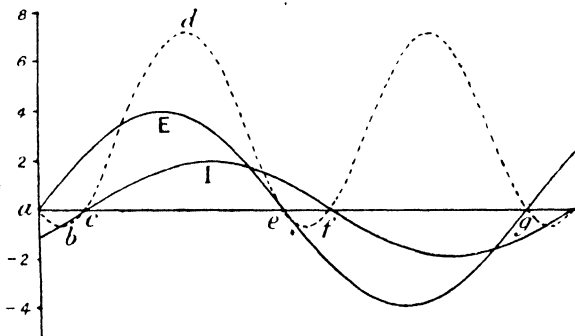

FIG. 326.

in the circuit. When the inductance of a circuit is so great in comparison with the resistance that the latter may be neglected, the current is entirely wattless; for in this case, $\theta = 90^\circ$, and $\cos \theta = 0$.

The curves for E and I in Fig. 326 are drawn for a case in which the current lags behind the electromotive force by an amount ac . For the parts of the cycle ce and fg the electromotive force and current

are in the same direction, and the source of energy is doing work upon the circuit. If we call this work positive, then for the parts *ac* and *cf* of the cycle, when *E* and *I* are in opposite directions, the work is negative, which means that the electromotive force is employed in diminishing the current, or the circuit is doing work upon the source of energy. The curve *abcde*, etc., is drawn by taking ordinates at each point equal to the product of *E* and *I*, and the large loops such as *cde* represent work done on the circuit, and the small loops such as *abc* represent energy drawn from it. The difference in area of the two is a measure of the work done in one half cycle.

When $L = 0$, $\theta = 0$, and the current is in phase with the electromotive force. The small loops are then absent; but as *L* increases, the difference of phase increases up to 90° in the limiting case when *R* is negligible, and in this case the positive and negative loops are equal in size. Their difference is then zero, and the current is entirely wattless.

The case is similar to that of a frictionless pendulum; although the motion is alternating, the total work done by gravity upon the pendulum in a cycle is zero.

Power Factor.—On measuring separately the virtual volts and virtual amperes for a given circuit by means of a voltmeter and an ammeter and taking the product, we obtain the apparent watts. This is not the actual power absorbed in the circuit, unless the current is in phase with the electromotive force, for the product has yet to be multiplied by $\cos \theta$ to obtain the true watts. The ratio of true watts to apparent watts is called the power factor of the circuit.

Since,—true watts = (apparent watts) $\times \cos \theta$, we see that the power factor is equal to $\cos \theta$, where $\theta = \tan^{-1} \frac{I_p}{R}$.

Wattmeters.—The true power absorbed in any circuit may be measured directly by means of a suitable wattmeter, whose low resistance coil *P* is in series with the circuit, the high resistance shunt coil *Q* being connected to the points *A* and *B* (Fig. 327) between which the power to be measured is absorbed. In the case of the Kelvin watt balance (p. 246) the shunt circuit has in it a non-inductive resistance *R*₁ of high value. The mechanical force or couple between the two coils is proportional to the product of the currents in them, that in *P*

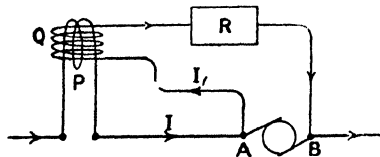

FIG. 327.

being the current *I* flowing in *AB*, and that in *Q* being proportional to, and in phase with, *E* the difference of potential between *A* and *B*. The instrument is calibrated to read directly in watts, and will therefore give the mean value of *E**I*, or the true power absorbed between *A* and *B*.

A difficulty arises owing to the fact that the coil Q always has some inductance, and the current in it therefore lags behind the electromotive force in it, causing the indicated mean value of the watts to be too low. In the Kelvin instrument this lag is reduced to a negligible amount by making the non-inductive resistance R_1 in the shunt circuit very great; while in the Addenbrooke electrostatic wattmeter, which is a modified quadrant electrometer, there is no appreciable lag.

If I_1 be the current in the shunt circuit Q, L_1 being the inductance, and R the resistance of the shunt circuit—

$$I_1 = \frac{E_0}{\sqrt{L_1^2 p^2 + R^2}} \sin (pt - \theta_1).$$

Also the current in the main circuit is—

$$I = I_0 \sin (pt - \theta),$$

and the instrument indicates the mean value of the product $I \times I_1$, that is—

$$\frac{E_0 I_0 \sin (pt - \theta) \sin (pt - \theta_1)}{\sqrt{L_1^2 p^2 + R^2}}.$$

Expanding the terms $\sin (pt - \theta)$ and $\sin (pt - \theta_1)$, and taking the product, this quantity becomes—

$$\frac{E_0 I_0}{\sqrt{L_1^2 p^2 + R^2}} \left\{ \sin^2 pt \cos \theta \cos \theta_1 + \cos^2 pt \sin \theta \sin \theta_1 - \frac{1}{2} \sin 2pt \sin (\theta + \theta_1) \right\}.$$

The mean values of $\sin^2 pt$ and $\cos^2 pt$ are both $\frac{1}{2}$, and of $\sin 2pt$ is zero, and the mean of the whole expression is therefore—

$$\frac{1}{2} \frac{I_0 E_0}{\sqrt{L_1^2 p^2 + R^2}} \cos (\theta - \theta_1).$$

The true power is $\frac{1}{2} I_0 E_0 \cos \theta$.

$$\therefore \frac{\text{indicated power}}{\text{true power}} = \frac{1}{\sqrt{L_1^2 p^2 + R^2}} \cdot \frac{\cos (\theta - \theta_1)}{\cos \theta}.$$

Since L_1 is small in comparison with R , $\sqrt{L_1^2 p^2 + R^2}$ does not differ from R in commercial instruments by more than 0.1 per cent., and the instrument, if calibrated with direct current, will read correctly on alternating current, provided that $\frac{\cos (\theta - \theta_1)}{\cos \theta}$ is equal to unity.

$$\begin{aligned} \frac{\cos (\theta - \theta_1)}{\cos \theta} &= \frac{\cos \theta \cos \theta_1 + \sin \theta \sin \theta_1}{\cos \theta} \\ &= \cos \theta_1 + \sin \theta_1 \cdot \tan \theta. \end{aligned}$$

When θ_1 is small this quantity approximates to unity unless θ is nearly 90° , in which case $\tan \theta$ approaches infinity. In general θ does not approach 90° , and the wattmeter may then safely be used.

The power factor of a circuit may then be measured by finding the true watts absorbed in it, by means of a wattmeter, and the apparent watts by means of an ammeter and voltmeter.

$$\text{Then, power factor} = \frac{\text{true watts}}{\text{apparent watts}} = \cos \theta.$$

Circuit containing Capacity, Inductance, and Resistance.—The equation of electromotive forces for a circuit having capacity, inductance and resistance is (see p. 331).

$$L \frac{dI}{dt} + RI + \frac{Q}{C} = E_0 \sin pt,$$

or, since $I = \frac{dQ}{dt}$ —

$$L \frac{d^2Q}{dt^2} + R \frac{dQ}{dt} + \frac{Q}{C} = E_0 \sin pt.$$

The simple harmonic part of the solution of this equation, that is, $Q = A \sin pt + B \cos pt$, may be found in an exactly similar manner to that given on p. 344. By differentiating, substituting, and solving the simultaneous equations for A and B , we find that—

$$A = \frac{E_0 \left(\frac{1}{Cp} - Ip \right)}{p \left\{ \left(\frac{1}{Cp} - Ip \right)^2 + R^2 \right\}}, \text{ and, } B = - \frac{E_0 R}{p \left\{ \left(\frac{1}{Cp} - Ip \right)^2 + R^2 \right\}},$$

and thus—

$$Q = \frac{E_0 \left(\frac{1}{Cp} - Ip \right)}{p \left\{ \left(\frac{1}{Cp} - Ip \right)^2 + R^2 \right\}} \sin pt - \frac{E_0 R}{p \left\{ \left(\frac{1}{Cp} - Ip \right)^2 + R^2 \right\}} \cos pt,$$

and further—

$$I = \frac{dQ}{dt} = \frac{E_0 \left(\frac{1}{Cp} - Ip \right)}{\left\{ \left(\frac{1}{Cp} - Ip \right)^2 + R^2 \right\}} \cos pt + \frac{E_0 R}{\left\{ \left(\frac{1}{Cp} - Ip \right)^2 + R^2 \right\}} \sin pt.$$

Taking as before, $\tan \theta = \frac{\frac{1}{Cp} - Ip}{R},$

we have,
$$I = \frac{E_0}{\sqrt{\left(\frac{1}{Cp} - Lp\right)^2 + R^2}} \sin (pt + \theta).$$

The impedance is in this case $\sqrt{\left(\frac{1}{Cp} - Lp\right)^2 + R^2}$.

The following four special cases are of interest.

(i) When $L = 0$ and $C = \infty$, then $\theta = 0$ and $\tan \theta = 0$, and the equation reduces to $I = \frac{E_0}{R} \sin pt$.

This case has already been discussed (p. 345).

(ii) When $C = \infty$, then $\tan \theta = -\frac{Lp}{R}$, and the equation is—

$$I = \frac{E_0}{\sqrt{L^2 p^2 + R^2}} \sin (pt - \theta).$$

The vector diagram and the electromotive force and current curves are given in Fig. 323.

(iii) When $L = 0$, then $\tan \theta = \frac{1}{CpR}$,

and,
$$I = \frac{E_0}{\sqrt{\frac{1}{C^2 p^2} + R^2}} \sin (pt + \theta).$$

The current is here in advance of the electromotive force by the difference in phase, $\theta = \tan^{-1} \frac{1}{CpR}$

The vector diagram is given in Fig. 328 (i) and the electromotive force and current curves for one cycle in Fig. 328 (ii). The power

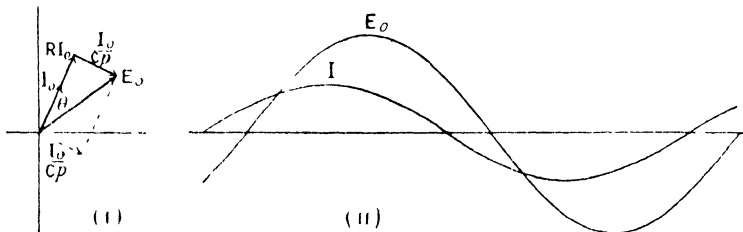

FIG. 323.

absorbed in the circuit is again $\frac{1}{2} I_0 E_0 \cos \theta$, and the idle or wattless component of the current is $I_0 \sin \theta$ (see p. 350).

If in addition, $R = 0$, then $\theta = 90^\circ$, and the current is entirely wattless.

(iv) When
$$Lp = \frac{1}{Cp}, \theta = 0,$$

then,
$$I = \frac{E_0}{R} \sin pt.$$

In this case the current is in phase with the electromotive force. The electromotive forces corresponding to the two wattless currents, one due to the inductance and the other due to the capacity, are equal

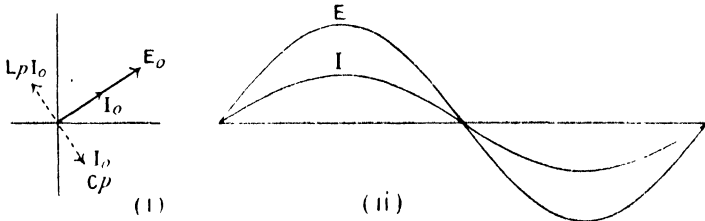

FIG. 329.

and are in opposite phases. We may say that the wattless current required by the inductance is supplied by the capacity (Fig. 329).

Choking Coil.—For many purposes it is required to reduce the current in a given circuit, with a minimum waste of energy, when the current is derived at constant voltage from a given supply. In charging a secondary battery from electric mains, an adjustable resistance is included in the circuit, whose function it is to reduce the current to the required amount, or in other words, to reduce the difference of potential between the ends of the battery to that required for charging. Similarly in running an arc lamp on a continuous current supply, the arc requires about 40 volts, so that if a current of 10 amperes is to be taken from 100-volt mains, the resistance to be included in the circuit is $\frac{100 - 40}{10} = 6$ ohms. It is merely a matter

of applying the ohmic relation $I = \frac{E}{R}$. With an alternating current supply there is another and more economical method which may frequently be employed as an alternative to introducing a resistance; for, let an inductance L be placed in series,

then,
$$I_0 = \frac{E_0}{\sqrt{L^2p^2 + R^2}},$$
 and in the above case,
$$10 = \frac{100}{\sqrt{L^2p^2 + 4^2}},$$

4 being the effective resistance, $\frac{40}{10}$, of the arc.

$$\therefore L^2p^2 + 16 = 100,$$

$$L^2p^2 = 84, \text{ and } Lp = 9.2 \text{ approx.}$$

If now the supply has a frequency of 50 cycles per second--

$$p = 2\pi \cdot 50.$$

$$\therefore L = \frac{92}{2\pi \cdot 50} = 0.029 \text{ henry.}$$

Such an inductance is called a choking coil. Its chief advantage lies in the fact that with it, the only waste of energy is due to the hysteresis loss in the iron core (p. 280), which is generally much less than the waste of energy in the resistance that would reduce the current to the same extent as the choking coil. The resistance of the choking coil is generally negligible. When a resistance is used to reduce the voltage, there is a waste of energy I^2R , which in the above example amounts to 600 watts, but with the choking coil the only additional electromotive force introduced, differs by 90° in phase with the current, and the effect is therefore wattless.

The virtual volts between the points A and C due to the supply

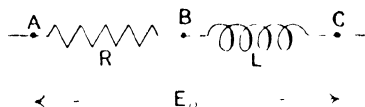

FIG. 330.

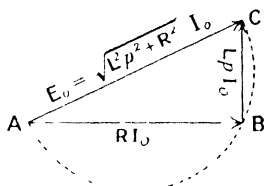

FIG. 331.

being E volts, that between the ends AB (Fig. 330) of the non-inductive resistance is RI , and that between the ends BC of the inductance is LpI (p. 316), and the latter differs in phase by 90° from the potential difference RI due to the resistance, since this is in phase with the current. The three electromotive forces are therefore related as the three sides of a right-angled triangle, as shown in Fig. 331. Thus the sum of the potential differences between A and B, and B and C, is always greater than the potential difference between A and C. Then we may find Lp graphically by constructing a semicircle upon AC (Fig. 331), and making AB equal to the fraction of AC that the required potential difference between the ends of the resistance is of the whole potential difference. On joining CB and dividing its length to scale by I , we obtain Lp .

Duddell Oscillograph.—Several devices have been employed to determine the wave form of an alternating electromotive force or current, but probably the most convenient is that used by W. Duddell¹ in the instrument known as the oscillograph. This is essentially a dead beat galvanometer, modified to have an exceedingly high frequency of vibration (8000 to 10,000) of the moving part, so that its

¹ W. Duddell and E. W. Marchant, *Inst. El. Eng. Journ.*, 28, p. 1. 1899.

movement copies the comparatively low frequency force due to the alternating current.

The phosphor-bronze strip *ssss* passes over the pulley P (Fig. 332), the ends being attached to terminals fixed in the block K. A spring, not shown in the figure, pulls P upwards, and maintains a considerable tension in the strip, whose lower portions are situated in the magnetic field due to a powerful electro-magnet.

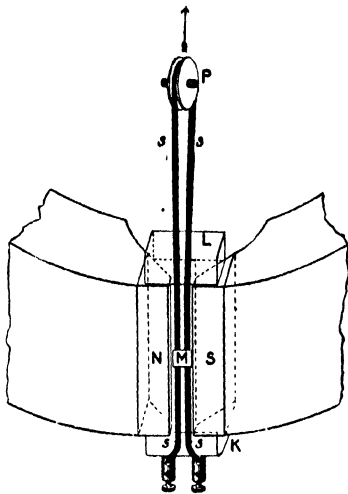

FIG. 332.

On passing a current through the strip, one limb is urged outwards and the other inwards, causing the light mirror M, attached to them, to rotate. The deflection of a beam of light reflected from M is thus proportional at every instant to the current flowing in the strip. The spot of light, falling upon a screen or photographic plate describes a straight line when an alternating current is passing.

In order to exhibit the variation of the current, the beam of light is

also reflected by a mirror which is rotating about an axis at right angles to the axis of rotation of M, so that the spot of light has a motion upon the screen proportional to time, at right angles to that proportional to the current, and hence describes a path similar to the curves of Fig. 333. The motion of the second mirror is produced by a synchronous motor driven by the alternating current under examination, so that the spot moves over the path repeatedly, an advantage in observing it, as the appearance upon the screen is that of a steady curve.

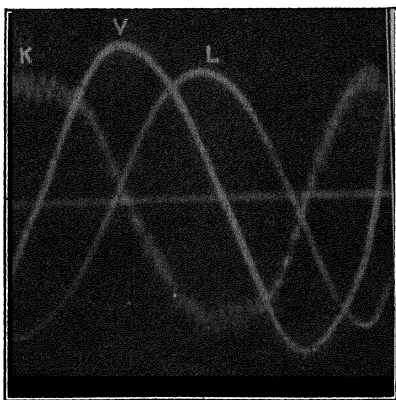

FIG. 333.

For the examination of the electromotive force and current curves

simultaneously, two strips such as *s* are placed side by side, the current strip is placed in shunt across a low resistance in which the current to be examined is flowing. The potential strip is placed in series with a high, non-inductive resistance, the ends of this circuit connected to the terminals between which the variation of potential difference to be examined is occurring. The current and potential curves may be arranged to fall simultaneously upon the screen, and in this way the curves in Fig. 333 have been obtained, *L* being the current curve with large inductance, and *K* that with large capacity, the lead being nearly 90° for the latter, and the lag nearly 90° for the former (see p. 354). *V* is the voltage curve.

Transformers.—The industrial use of alternating currents owes its development entirely to the transformer, which is an appliance for converting large current at low voltage to low current at high voltage, and *vice versa*, with very small loss in energy and without the necessity of moving parts in the appliance. Thus for the transmission of 10,000 watts at 100 volts the current is 100 amperes, but at 10,000 volts the current is only one ampere. Hence the conductor required in the second case will be much smaller, and therefore less expensive than in the first, although this must to a certain extent be compensated for by the better insulation required for the higher voltage transmission.

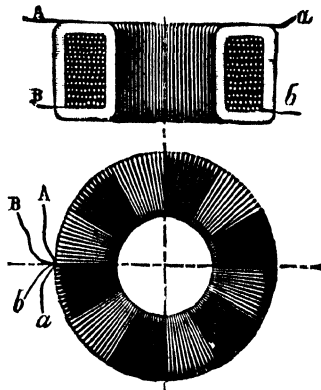

FIG. 334.

The transformer consists essentially of two coils, a primary and a secondary, wound upon an iron core, the function of which is to make the mutual inductance of the coils as great as possible. The relative number of turns in the two coils depends

upon whether it is required to transform up or down in voltage. The induction coil is an example of a transformer for transforming up; that is from low to high voltage. An ordinary transformer with closed magnetic circuit is shown in Fig. 334, *AB* being the primary and *ab* the secondary coil.

We have already found on p. 315 that the electromotive force equations for two circuits having mutual inductance, are—

$$L_1 \frac{dI_1}{dt} + M \frac{dI_2}{dt} + R_1 I_1 = E_1 \dots \dots \dots (i)$$

$$L_2 \frac{dI_2}{dt} + M \frac{dI_1}{dt} + R_2 I_2 = 0 \dots \dots \dots (ii)$$

When an electromotive force E_1 is applied to the first circuit, there being no source of electromotive force, (other than that due to the mutual actions of the currents,) applied to the second, and E_1 vary harmonically, it may be written ${}_0E_1 \sin pt$, and the harmonic solutions for I_1 and I_2 might be obtained as on page 344. But this process is extremely tedious, and the useful results may all be obtained by starting with the currents and afterwards finding the impressed electromotive forces required to produce these currents. Assuming then that the currents I_1 and I_2 differ in phase by the angle θ , we may write them, taking ${}_0I_1$ and ${}_0I_2$ for the maximum values—

$$I_1 = {}_0I_1 \sin pt \dots \dots \dots \text{(iii)}$$

and,

$$I_2 = {}_0I_2 \sin (pt + \theta) \dots \dots \dots \text{(iv)}$$

In practice these currents will not be true sine functions, owing to the hysteresis in the iron core of the transformer, but will consist of a sine term together with a higher harmonic due to hysteresis, which is wattless,¹ and may usually be neglected; its study belongs to the province of the electrical engineer.

From equations in and iv we get—

$$\frac{dI_1}{dt} = p {}_0I_1 \cos pt, \quad \text{and,} \quad \frac{dI_2}{dt} = p {}_0I_2 \cos (pt + \theta).$$

Substituting in equation (i) we get—

$$\begin{aligned} &L_2 p {}_0I_2 \cos (pt + \theta) + Mp {}_0I_1 \cos pt + R_2 {}_0I_2 \sin (pt + \theta) = 0, \\ \text{or,} \quad &(L_2 p {}_0I_2 \cos \theta + Mp {}_0I_1 + R_2 {}_0I_2 \sin \theta) \cos pt \\ &\quad + (R_2 {}_0I_2 \cos \theta - L_2 p {}_0I_2 \sin \theta) \sin pt = 0. \end{aligned}$$

This is true for all values of t , and therefore when $pt = \frac{\pi}{2}$, we have—

$$R_2 {}_0I_2 \cos \theta - L_2 p {}_0I_2 \sin \theta = 0,$$

$$\text{or,} \quad \tan \theta = \frac{R_2}{L_2 p}, \quad \text{and} \therefore \sin \theta = \frac{R_2}{\sqrt{L_2^2 p^2 + R_2^2}}$$

When $t = 0$, we have—

$$L_2 p {}_0I_2 \cos \theta + Mp {}_0I_1 + R_2 {}_0I_2 \sin \theta = 0.$$

$$\begin{aligned} \text{And,} \quad \frac{{}_0I_2}{{}_0I_1} &= - \frac{Mp}{L_2 p \cos \theta + R_2 \sin \theta} \\ &= - \frac{Mp}{L_2 p \frac{R_2}{\sqrt{L_2^2 p^2 + R_2^2}} + R_2 \frac{L_2 p}{\sqrt{L_2^2 p^2 + R_2^2}}} \end{aligned}$$

$$\therefore {}_0I_2 = - \frac{Mp {}_0I_1}{\sqrt{L_2^2 p^2 + R_2^2}}$$

¹ Steinmetz and Berg, "Alternating Current Phenomena."

From these two results we see that there is a difference in phase between the primary and secondary currents determined by the last relation, together with the fact that $\tan \theta = \frac{R_2}{L_2 p}$.

Returning to equation (1), and substituting in it the values of $\frac{dI_1}{dt}$, $\frac{dI_2}{dt}$, and I_1 , we have—

$$\begin{aligned} & L_1 p {}_0I_1 \cos pt + M p {}_0I_2 \cos (pt + \theta) + R_1 {}_0I_1 \sin pt = E_1, \\ \therefore E_1 &= (R_1 {}_0I_1 - M p {}_0I_2 \sin \theta) \sin pt + (L_1 p {}_0I_1 + M p {}_0I_2 \cos \theta) \cos pt, \\ &= \left(R_1 {}_0I_1 + M p \frac{M p \cdot {}_0I_1}{\sqrt{L_2^2 p^2 + R_2^2}} \cdot \frac{R_2}{\sqrt{L_2^2 p^2 + R_2^2}} \right) \sin pt \\ &\quad + \left(L_1 p {}_0I_1 - M p \frac{M p \cdot {}_0I_1}{\sqrt{L_2^2 p^2 + R_2^2}} \cdot \frac{L_2 p}{\sqrt{L_2^2 p^2 + R_2^2}} \right) \cos pt, \\ &= {}_0I_1 \left(R_1 + \frac{M^2 p^2 R_2}{L_2 p^2 + R_2^2} \right) \sin pt + {}_0I_1 \left(L_1 p - \frac{M^2 p^2 \cdot L_2 p}{L_2 p^2 + R_2^2} \right) \cos pt, \\ &= {}_0I_1 \sqrt{\left(R_1 + \frac{M^2 p^2 R_2}{L_2 p^2 + R_2^2} \right)^2 + p^2 \left(L_1 - \frac{M^2 p^2 \cdot L_2}{L_2 p^2 + R_2^2} \right)^2} \sin (pt + \phi), \end{aligned}$$

where,

$$\tan \phi = \frac{\left(L_1 - \frac{M^2 p^2 L_2}{L_2 p^2 + R_2^2} \right) p}{R_1 + \frac{M^2 p^2 R_2}{L_2 p^2 + R_2^2}}$$

We therefore see that the primary electromotive force leads the primary current by an angle ϕ , or, what is the same thing, the current lags behind the voltage by this angle. Further, the primary resistance is increased by an effective amount $\frac{M^2 p^2 R_2}{L_2 p^2 + R_2^2}$ due to the current in the secondary, and the primary inductance is effectively reduced by the amount $\frac{M p L_2}{L_2 p^2 + R_2^2}$, a phenomenon first pointed out by Maxwell.¹

Writing $\frac{M p}{\sqrt{L_2^2 p^2 + R_2^2}} = P$, we may then express our currents in terms of E_1 , taking $E_1 = {}_0E_1 \sin pt$, and rewriting our equations, (iii) becomes—

$$I_1 = \frac{{}_0E_1}{\sqrt{(L_1 - P^2 L_2) p^2 + (R_1 + P R_2)^2}} \sin (pt - \phi) \quad \dots (v)$$

$$= {}_0I_1 \sin (pt - \phi) \quad \dots \dots \dots (vi)$$

where, $\tan \phi = \frac{(L_1 - P L_2) p}{(R_1 + P R_2)}$.

¹ J. C. Maxwell, *Phil. Trans. Roy. Soc.*, 155, p. 459. 1865.

Again, since ${}_0I_2 = -P {}_0I_1$, (iv) becomes—

$$\begin{aligned} I_2 &= {}_0I_2 \sin(\rho t - \phi + \theta) \\ &= -P {}_0I_1 \sin(\rho t - \phi + \theta) \\ &= P {}_0I_1 \sin(\rho t - \phi + \theta - \pi). \end{aligned}$$

For the difference of phase between I_1 and I_2 is the advance θ , of the latter ahead of the former, together with a lag of π implied by the relation ${}_0I_2 = -P {}_0I_1$.

Now $\tan \theta = \frac{R_2}{L_2 \rho}$, so that $\tan \theta' = \frac{L_1 \rho}{R_2}$, where $\theta = \frac{\pi}{2} - \theta'$, and substituting this value for θ we have—

$$I_2 = P {}_0I_1 \sin\left(\rho t - \phi - \theta' - \frac{\pi}{2}\right),$$

and the actual lag of the secondary current behind the primary is an angle $\theta' + \frac{\pi}{2} = \pi - \theta$. The complete expression for I_2 is now—

$$I_2 = \frac{{}_0E_1 P}{\sqrt{(L_1 - P^2 L_2) \rho^2 + (R_1 + P^2 R_2)}} \sin\left(\rho t - \phi - \theta' - \frac{\pi}{2}\right). \quad \text{(vii)}$$

$$= {}_0I_2 \sin\left(\rho t - \phi - \theta' - \frac{\pi}{2}\right). \quad \dots \dots \dots \text{(viii)}$$

The meaning of these equations can be more clearly seen by drawing a vector diagram for the electromotive forces in the two circuits. The equations of electromotive force are (i) and (ii), and the various terms in them and their relative phases may be found from equations (v), (vi), (vii) and (viii). Thus, from (vi) we have

$$R_1 I_1 = R_1 {}_0I_1 \sin(\rho t - \phi).$$

Hence we will begin our diagram with the vector OE, whose value is ${}_0E_1$, the maximum of E_1 . At an angle ϕ behind this we have OA, equal to $R_1 {}_0I_1$, which is in phase with the primary current, ϕ being very nearly 90° since $L_1 \rho$ is usually large in comparison with R_1 .

Again, from (vi) we have—

$$L_1 \frac{dI_1}{dt} = L_1 \rho {}_0I_1 \sin\left(\rho t - \phi + \frac{\pi}{2}\right) \quad \text{(see p. 346).$$

Hence AB is drawn 90° ahead of OA, and is made equal to $L_1 \rho {}_0I_1$. From (viii)—

$$R_2 I_2 = R_2 {}_0I_2 \sin\left(\rho t - \phi - \theta' - \frac{\pi}{2}\right),$$

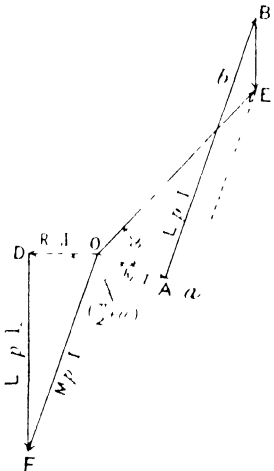

FIG. 335.

so that we next make OD equal to $R_2 \cdot {}_0I_2$ at an angle $\angle OAD = \theta + \frac{\pi}{2}$ behind OA, and this is in phase with the secondary current. Also from (viii)—

$$I_2 \frac{dI_2}{dt} = I_2 p \cdot {}_0I_2 \sin (pt - \phi - \theta'),$$

and therefore DF is drawn 90° ahead of OD and equal to $L_2 p \cdot {}_0I_2$. FO is now the vector sum of the two electromotive forces $L_2 \frac{dI_2}{dt}$ and $R_2 I_2$ in the secondary, and is equal to the electromotive force due to the variation of current in the primary, which is $M \frac{dI_1}{dt} = M p \cdot {}_0I_1 \sin \left(pt - \phi + \frac{\pi}{2} \right)$ from (vi), which we see is parallel to AB; and further the vector BE, which is the electromotive force in the primary due to the variation of the secondary current, is $M p \cdot {}_0I_2$, and is parallel to DF, since from (viii)—

$$M \frac{dI_2}{dt} = M p \cdot {}_0I_2 \sin (pt - \phi - \theta').$$

The three vectors OD, DF, and FO have zero resultant, and if the diagram rotates with constant angular velocity p , their projections on a fixed axis are at any instant the three terms in equation (ii).

Similarly the three vectors OA, AB, and BE, having a resultant equal to E, correspond to the three terms in equation (i).

If a perpendicular Ea be dropped from E on to OA, the vector Oa is equivalent to $R_1' \cdot {}_0I_1$ where R_1' is the effective resistance of the primary circuit, which we saw on p. 360 to be $R_1 + \frac{M^2 p^2 R_2}{L_2^2 p^2 + R_2^2}$.

The vector Aa is therefore equal to $\frac{M^2 p^2 R_1}{L_2^2 p^2 + R_2^2}$.

Similarly Ea is the quantity $L_1' p \cdot {}_0I_1$ where L_1' is the effective inductance of the primary, and the vector Bb is therefore equal to $\frac{M^2 p^2 L_2}{L_2^2 p^2 + R_2^2}$ so that the lag (ϕ) of primary current behind the electromotive force which occurs when the current in the secondary is ${}_0I_2$, might be reproduced when ${}_0I_2$ is zero by increasing the primary resistance by the amount Aa, and diminishing the primary inductance by the amount Bb.

When the secondary circuit is broken so that ${}_0I_2$ is zero, the current in the primary is $\frac{{}_0E_1}{\sqrt{L_1^2 p^2 + R_1^2}}$ and the rate of working is ${}_0E_1 \cdot {}_0I_1 \cos \phi$, where ϕ is now $\tan^{-1} \frac{L_1 p}{R_1}$. The only work done, apart from that due to hysteresis and eddy currents, is that required to drive the current

through the primary in opposition to its resistance. The vector diagram reduces to the form shown in Fig. 336. Since R_1 is usually small in comparison with L_1 , ϕ is nearly 90° , and becomes more and more nearly equal to 90° as p increases. There is now only one electromotive force in the secondary, equal to $M p \text{ }_0I_1$; and since this is parallel to AE , the electromotive force in the secondary is very nearly opposite in phase to the primary electromotive force, OE . From its value $M p \text{ }_0I_1$, we see, calling it _0E_2 , that—

$$\text{ }_0E_2 = M p \text{ }_0I_1 = M p \frac{\text{ }_0E_1}{\sqrt{L_1^2 p^2 + R_1^2}}$$

and neglecting R_1 in comparison with $L_1 p$ —

$$\frac{\text{ }_0E_2}{\text{ }_0E_1} = \frac{M}{L_1}$$

When the primary and secondary coils are wound upon the core in such a way that they both enclose the whole of the magnetic induction, we have—

$$L_1 L_2 = M^2$$

for, $M = \frac{n_2}{n_1} L_1 = \frac{n_1}{n_2} L_2$, where n_1 and n_2 are the respective numbers

of turns in the primary and secondary $\therefore \frac{\text{ }_0E_2}{\text{ }_0E_1} = \frac{\sqrt{L_1 L_2}}{L_1} = \sqrt{\frac{L_2}{L_1}}$.

But the inductance of a coil is proportional to the square of the number of turns linked with the magnetic flux, and therefore $L_1 \propto n_1^2$, and $L_2 \propto n_2^2$.

$$\therefore \frac{\text{ }_0E_2}{\text{ }_0E_1} = \frac{n_2}{n_1}$$

That is, the electromotive forces in secondary and primary are proportional to their respective numbers of turns.

These conditions may be approximately fulfilled in the case of the induction coil (p. 319), the primary coil having very low and the secondary very high resistance, the latter being very great, not only on account of the number of turns being very great, and the wire employed being thin, but also by the fact that part of the circuit consists of air or some other medium of exceedingly high resistance.

Returning to the vector diagrams (Figs. 335 and 336) we may now consider the effect of reducing the resistance of the secondary until appreciable current passes in it. When this current is small, the vector OD is nearly at right angles to OF , so that the secondary

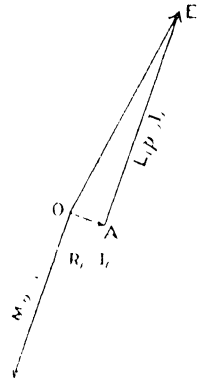

FIG. 336.

current is nearly opposite in phase to the primary. As work is now being performed in the secondary this implies that more power is taken in at the primary. This is supplied in two ways. In the first place the primary current comes more into phase with the electromotive force, since $\tan \phi$ changes from $\frac{L_1 p}{R}$ to—

$$\frac{\left(L_1 - \frac{M^2 p^2 L_2}{L_2^2 p^2 + R_2^2} \right) p}{R_1 + \frac{M^2 p^2 R_2}{L_2^2 p^2 + R_2^2}},$$

so that ϕ diminishes, and $\cos \phi$ increases, and the power $E_1 I_1 \cos \phi$ increases. But in addition to this, the primary current usually increases owing to a diminution in the effective primary impedance from $\sqrt{L_1^2 p^2 + R_1^2}$ to $\sqrt{(L_1 - P^2 L_2)^2 p^2 + (R_1 + P^2 R_2)^2}$.

If the latter of these two quantities is less than the former—

$$L_1^2 p^2 + R_1^2 > L_1^2 p^2 - 2L_1 L_2 P^2 p^2 + P^4 L_2^2 p^2 + R_1^2 + 2R_1 R_2 P^2 + P^4 R_2^2.$$

$$\therefore 2L_1 L_2 P^2 > P^2 (L_2^2 p^2 + R_2^2) + 2R_1 R_2.$$

But,

$$P^2 = \frac{M^2 p^2}{L_2^2 p^2 + R_2^2}.$$

$$\therefore 2L_1 L_2 P^2 > M^2 p^2 + 2R_1 R_2.$$

In the case of an ordinary transformer, R_1 and R_2 are made as small as possible, in order to avoid loss of energy due to heating of the conductors. Therefore, neglecting the term $2R_1 R_2$, we have—

$$2L_1 L_2 > M^2,$$

a condition which is necessarily fulfilled since M^2 cannot be greater than $L_1 L_2$. Thus the result of the current in the secondary is to decrease the effective impedance of the primary, and the primary current therefore increases. It should be noted that if the resistances are not small it does not follow that the effective impedance of the primary is reduced and the current increased. There is, however, always an increase in the power absorbed by the primary, on account of the advance in phase of the primary current caused by the current in the secondary.

For an account of the efficiency of transformers and the measurement of the various losses occurring in them the student is referred to works on electrical engineering.

Resistance and Inductance of Wires for Currents of High Frequency.—A steady current flowing in a uniform wire is distributed uniformly in the cross-section of the wire, the current density being constant over any given section. When the voltage applied between the ends of the wire is alternating, the distribution of current is no longer uniform; there is a concentration of the current in the outer

layers, and, when the frequency is very great, the current is almost entirely confined to the surface layer. This phenomenon is known as the "skin effect," and on account of it, the effective resistance of the wire is greatly increased. For this reason, conductors that are required to carry high frequency alternating currents are made up of a number of strands of fine wire, insulated from each other, in order to have a large surface for any given area of cross-section, since the central parts of thick wires would not carry any appreciable part of the current and would therefore be useless

The reason for this distribution of the current may be understood by examining Fig. 229, in which the magnetic field for a wire carrying steady current is shown. Taking any cylindrical shell of the wire, the magnetic field outside it is the same as though the current in the shell were all at the axis of the wire, but for points inside the shell the field is zero. Thus for a given current, the total magnetic flux is greater when the current flows along the axis than when it flows in a surface layer of the wire, by the amount of flux that fills the space occupied by the wire when the current flows along the axis.

If then we imagine two elements of the wire of equal cross-section, one constituting the central portion A, in Fig. 337, and the other a cylindrical shell B, these will carry equal currents when the electromotive force is steady, but A will have a greater self-inductance than B. When the electromotive force is alternating, B will therefore have the less impedance, and more current will flow in it; and further, the current in A will lag behind that in B, owing to the greater inductance of A. The phase of the current gets later and later as we pass from the surface of the wire to the interior. This is entirely in accordance with the fact that the flow of energy from the source of electromotive force takes place in the dielectric surrounding the wire, time being necessary for it to penetrate from the surface to the interior. This aspect of the question will be studied later (see p. 410).

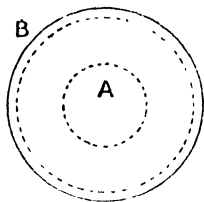

FIG. 337.

If we consider a conductor consisting of the two parts A and B only, where the resistance of each for steady current is R, the inductance of A being L, that of B is equal to M, the mutual inductance of the two parts; since the magnetic flux linked with the circuit whose cross-section is B, is also linked with A, and if we apply an alternating electromotive force $E_0 \sin pt$ to the two in parallel, we see by the equations on p. 360, that the effective resistance of A is—

$$R + \frac{M^2 p^2 R}{M^2 p^2 + R^2} = R \left(1 + \frac{M^2 p^2}{M^2 p^2 + R^2} \right),$$

and its effective inductance is—

$$L - \frac{M^2 p^2 M}{M^2 p^2 + R^2},$$

while the effective resistance and inductance of B are respectively—

$$R + \frac{M^2 p^2 R}{L^2 p^2 + R^2} = R \left(1 + \frac{M^2 p^2}{L^2 p^2 + R^2} \right),$$

and,

$$M - \frac{M^2 p^2 L}{L^2 p^2 + R^2}.$$

The total resistance is therefore in each case increased, and the effective inductance reduced, the change depending on the square of p ; but since $L > M$, the resistance of A rises more rapidly than that of B when p increases, so that the current becomes at very high frequency almost entirely confined to B. The better the conductivity of the material the smaller is the value of R , and therefore the greater is the quantity

$\frac{M^2 p^2 M}{M^2 p^2 + R^2}$ or $\frac{M^2 p^2 L}{L^2 p^2 + R^2}$, the limiting values when $R = 0$ being M and $\frac{M^2}{L}$. Since $\frac{M}{L} < 1$, M is greater than $\frac{M^2}{L}$, and the concentration of the current into B is greater when R is small than when it is great, for in this latter case $\frac{M^2 p^2 M}{M^2 p^2 + R^2}$ and $\frac{M^2 p^2 L}{L^2 p^2 + R^2}$ approach to equality.

If the wire consist of a material of high permeability, L is enormously increased while M is practically unchanged. This again accentuates the crowding of the current into the outer layers; in other words it increases the skin effect.

The problem of the distribution of an alternating current in an actual wire is beyond the scope of this book, but it may be pointed out that in the case of a straight circular wire carrying alternating current, the effective resistance R' may be calculated from a relation which may be written in the form—

$$R' = R \left\{ 1 + \frac{1}{12} \left(\frac{2\pi n \mu a^2}{\rho} \right)^2 - \frac{1}{180} \left(\frac{2\pi n \mu a^2}{\rho} \right)^4 + \dots \right\},$$

given by Lord Rayleigh,¹ where R is the resistance for steady current, a being the radius of the wire in centimetres, n the frequency of alternation, and ρ the specific resistance of the material of the wire in absolute units, provided that $\frac{4\pi^2 a^2 \mu n}{\rho}$ is not greater than 5. For very high frequencies the relation is—

$$R' = R \sqrt{\frac{\pi^2 n \mu a^2}{\rho}}.$$

The effective resistance of a straight wire for high frequency currents has been measured by Prof. J. A. Fleming² by comparing the

¹ Lord Rayleigh, *Phil. Mag.* (Ser. 5), **21**, p. 381. 1886.

² J. A. Fleming, *Proc. Phys. Soc. Lond.*, **23**, p. 103. 1911.

currents in two similar wires that produce heating at the same rate, the current in one wire being steady and the other oscillating. The arrangement employed is shown diagrammatically in Fig. 338. The two wires AB and CD are situated in glass tubes which are united by a bent tube containing a little paraffin oil, with an air bubble at P. The currents in AB and CD are adjusted until the air bubble remains in its equilibrium position, the system then acting as a differential air thermometer; it indicates that the rates of production of heat in the wires are equal.

The alternating current is measured by an ammeter of the type described on p. 222, which measures virtual amperes. It consists in the oscillatory discharge from a condenser, the frequency of oscillation being determined by means of the cymometer (p. 460).

For equal heating in the two wires, $I^2R = I'^2R'$ where I' is the virtual current, and R' the effective resistance, I and R being the values for steady current.

Since the wires and the vessels may not be identical in the rates at which the heat produced in the wires is dispersed, the currents are interchanged, so that the wire which previously carried the alternating current now carries the steady current, the effect of dissimilarity in the tubes and wires being in this way eliminated. The observations were in very good agreement with the calculated results. In the case of a bare copper wire of diameter 0.03149 cm. the resistance for a frequency of 1.08×10^6 is 1.45 times that for steady current, while for a diameter of 0.198 the ratio is 8.10.

Shielding Effect of a Mass of Metal.—The presence of a mass of conducting material in the neighbourhood of a circuit carrying alternating current produces an effect which may be understood from the equations on p. 360. The effective self-inductance of the circuit is reduced, for the induced current in the material has a magnetic field which is opposite in sign to that due to the current in the circuit, and consequently while the current is growing, the magnetic flux linked with the circuit is less than would be the case if the mass of metal were absent. The back electromotive force, due to the growth of the magnetic flux, is therefore reduced, which is equivalent to saying that the effective self-inductance is diminished. Similarly at stopping, the induced current is in the direction of that in the circuit (see Fig. 309), and the flux dies away at a lessened rate.

As the conductivity of the material increases, so the effect is enhanced, for the induced currents become greater, while the reverse is the case when the conductivity is diminished. For this reason it is

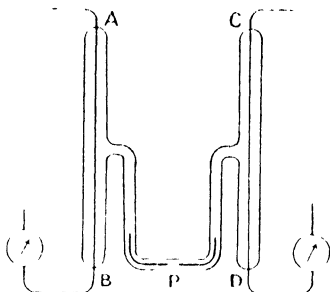

FIG. 338.

necessary to avoid using continuous masses of metal in the construction of coils of large inductance. The frame on which the coil is wound should be of some non-conducting material, and if this is inconvenient, a saw cut should be made in a direction at right angles to the direction of the electromotive force produced by the varying magnetic flux. This enormously diminishes the effect. Further, if an iron core is employed, it should be laminated or else built up of wires insulated from each other. A slight film of oxide on the wires or laminae will be highly beneficial. For this reason the cores of transformers are usually laminated, for not only is the effect of these eddy currents upon the inductance objectionable, but they involve a waste of energy, the current in the metal involving a conversion of electrical energy into heat within the material.

In a similar manner a sheet or mass of highly conducting metal may be used to screen a given space from the effects of an alternating magnetic field.

Let an alternating current $I_1 = I_0 \sin pt$, be flowing in a given circuit; then for a neighbouring circuit or mass of metal, the equation of electromotive forces will be—

$$I_2 \frac{dI_2}{dt} + M \frac{dI_1}{dt} + R_2 I_2 = 0.$$

When R_2 is very small, as we may suppose it to be in the given case—

$$I_2 \frac{dI_2}{dt} + M \frac{dI_1}{dt} = 0.$$

$$\therefore LI_2 + MI_1 = \text{constant.}$$

$I_2 I_2$ is the magnetic flux through the closed circuit due to the current I_2 in it, and MI_1 is the flux due to the current I_1 , and since the sum of these two is constant, the variation in flux, which, without the closed circuit would be

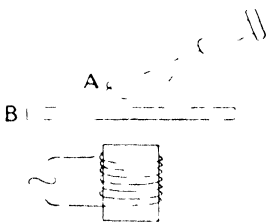

FIG. 339.

$$M_0 I_1 \sin pt,$$

is reduced to zero. This effect may be demonstrated by placing a coil A (Fig. 339) which is in series with a telephone receiver, near an electromagnet excited by an alternating current. A note whose pitch is equal to twice the frequency of

alternation of the current will be heard in the telephone. If now a thick sheet of copper, B, be placed near A, the loudness of the note is much reduced. The sound will never disappear, for the sheet cannot have absolutely zero resistance, and consequently the limiting condition implied by the last equation is never reached.

It may be noted that unless the alternations are extremely rapid,

the effect of the presence of the plate is considerable, on whichever side of the coil **A** it is placed, and is greater the nearer it is to **A**. If the magnet is at some distance, it is immaterial on which side of **A** the plate is situated, for it is the variation in flux at **B** that is reduced, and there is a consequent reduction in the variation at all points near **B**. A radial slot cut in the plate **B** enormously increases its resistance to the induced currents and correspondingly diminishes the effect.

Repulsion between Conductor and a Circuit carrying Alternating Current.—(Closely allied to the last described effect is the phenomenon of repulsion that occurs between a circuit carrying an alternating current, and a conductor. A closed circuit or conductor **A** (Fig. 340) situated near an alternating electromagnet, is threaded by a magnetic flux $MI_0 \sin pt$, due to the current $I_0 \sin pt$, in the electromagnet.

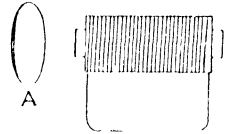

FIG. 340.

Since **A** has very small inductance, its reaction upon the electromagnet is infinitesimal, and we may consider that an alternating electromotive force $-M \cdot \frac{dI}{dt} = -MpI_0 \cos pt = MpI_0 \sin \left(pt - \frac{\pi}{2} \right)$ acts in it. This electromotive force is 90° in phase behind the current I_0 , and neglecting **A**'s inductance, the current in it will be in phase with this electromotive force. Thus—

$$I_2 \propto MpI_0 \sin \left(pt - \frac{\pi}{2} \right).$$

There will be a force between the two currents, proportional to their product $I_1 I_2$.

$$\therefore \text{Force} \propto MpI_0^2 \sin pt \sin \left(pt - \frac{\pi}{2} \right).$$

We have already seen (p. 350) that the mean value of a quantity such as $\sin pt \sin \left(pt - \frac{\pi}{2} \right)$, in which the two harmonic components differ in phase by 90° , is zero, and therefore if the inductance of **A** be zero, the mean force on it is also zero. But the inductance, although small, cannot be zero, and the current I_2 therefore lags in phase by more than 90° behind I_1 .

$$\begin{aligned} \therefore \text{Force} &\propto MpI_0^2 \sin pt \sin \left(pt - \frac{\pi}{2} - \theta \right), \\ &\propto MpI_0^2 \sin^2 pt \cos \left(\frac{\pi}{2} + \theta \right) - \frac{MpI_0^2}{2} \sin 2pt \sin \left(\frac{\pi}{2} + \theta \right). \end{aligned}$$

The mean value of the last term we saw on p. 350 to be zero, and the mean of the first is $\frac{1}{2} MpI_2 \cos \left(\frac{\pi}{2} + \theta \right)$. Since $\cos \left(\frac{\pi}{2} + \theta \right)$ is necessarily negative when θ is small, the force on **A** is a repulsion, and the coil

A experiences in each complete cycle, an impulse pushing it away from the magnet. The curves for I_1 and I_2 are drawn in Fig. 341, and the dotted curve is drawn for the product $I_1 I_2$. Owing to the phase difference between I_1 and I_2 being greater than 90° (compare with Fig. 326, where the phase difference is less than 90°) the positive loops *a*, which indicate an attraction owing to the currents being in the same direction, are smaller than the negative loops *b* which indicate a repulsion. It is thus seen that the repulsions predominate.

It may be seen from the expression for the force, that this increases

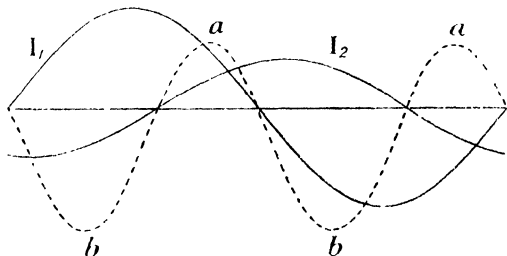

FIG. 341.

with p , and with the square of the current I_0 . Hence, to get large effects, currents of considerable value and of high frequency are necessary.

The resistance of *A* plays an important part in the phenomenon, for the lower the resistance the greater the induced current in it and the larger the effect. But the lower the resistance, the greater is the lag of the current behind the electromotive force owing to the increase in the time constant, and hence the lag θ increases, the result being that the loops *b* in Fig. 341 are increased while the loops *a* are diminished, the repulsion being still further increased.

By means of powerful alternating-current electromagnets, metal rings of considerable weight may be supported.

Rotating Magnetic Field.—If two coils carrying alternating currents be placed at right angles to each other, the resulting magnetic field at any instant may be found by compounding the fields due to the two coils, according to the ordinary law of addition of vector quantities or parallelogram of forces. When the currents have the same frequency, the resultant magnetic field at any point is periodic, and has the same frequency as the currents.

Representing the currents by the equations $I_1 = I_0 \sin (pt + \theta)$ and $I_2 = I_0 \sin pt$, the magnetic fields are in phase with the respective currents and may be represented by—

$$\begin{aligned} H_1 &= H_0 \sin (pt + \theta) \\ H_2 &= H_0 \sin pt. \end{aligned}$$

and,

If the field H_1 be due to the current in the coil AB (Fig. 342) it may be represented by the vector OH_1 , and the field due to the coil CD is represented by OH_2 , and at the instant to which the diagram refers, OH' is the resultant field. This has the value $\sqrt{H_1^2 + H_2^2}$, and is inclined to the direction of OH_1 by an angle ϕ whose tangent is $\frac{H_2}{H_1}$, that is, $\tan \phi = \frac{H_2}{H_1}$. Both H' and ϕ , which define the resultant field, vary periodically; for when $t = 0$, then $H_2 = 0$, and

$$H' = {}_0H_1 \sin \theta.$$

Also when $t = -\frac{\theta}{p}$, $H_1 = 0$, and $H' = {}_0H_2 \sin(-\theta)$.

Thus the resultant field H' rotates, and at the same time varies in magnitude.

The case of most importance is that in which ${}_0H_1 = {}_0H_2 = H_0$.

Then, $H' = H_0 \sqrt{\sin^2 pt + \sin^2 (pt + \theta)}$,

and, $\tan \phi = \frac{\sin pt}{\sin (pt + \theta)}$;

and if in addition $\theta = \frac{\pi}{2}$, then—

$$H' = H_0, \text{ and } \tan \phi = \frac{\sin pt}{\cos pt} = \tan pt,$$

that is, $\phi = pt$. The resultant field is therefore constant in value, and rotates with constant angular velocity p .

Then at time $t = 0$, $H_1 = H_0$, and $H_2 = 0$, and the position of H' is O_0H_1 (Fig. 343). At time $t = \frac{\pi}{2p}$, $H_1 = 0$, and $H_2 = H_0$, and the position of H' is O_0H_2 . Hence the direction of rotation of H' is positive, that is from OD to OA, or anti-clockwise, when H_1 is 90° in phase ahead of H_2 .

If, on the other hand, H_1 lags 90° in phase behind H_2 —

$$H_1 = H_0 \sin \left(pt - \frac{\pi}{2} \right) = -H_0 \cos pt,$$

and, $H_2 = H_0 \sin pt$,

$$\tan \phi = -\tan pt, \text{ and } \phi = -pt.$$

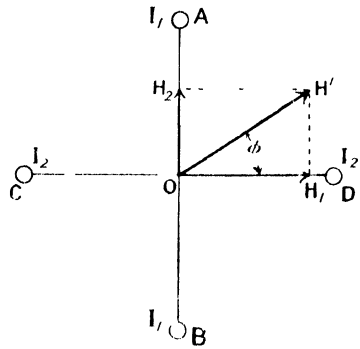

FIG. 342.

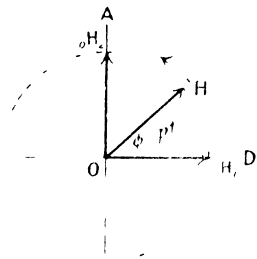

FIG. 343.

The direction of rotation of the resultant field H' is therefore in this case negative, that is, opposite to that of the rotation of the vectors ${}_0H_1$ and ${}_0H_2$, and its angular velocity is $-\rho$.

A conductor placed at O will consequently experience a couple, which is in all cases in the direction of rotation of the resultant field, for an exactly similar reason to that for which the magnet rotates in Arago's experiment, described on p. 251. In this case the field rotates, whereas in Arago's experiment the conductor rotates, but in both experiments it is the relative motion that determines the couple between them, for by Lenz's law (p. 250) we know that the forces due to the magnetic effects between the field due to the induced currents, and the original field, are such as to oppose the relative motion of the field and conductor.

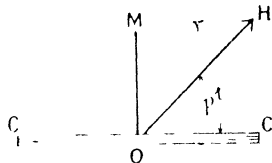

FIG. 344.

The couple acting on a mass of metal situated in a rotating magnetic field cannot in general be calculated, because of the difficulty in finding the distribution of the induced currents in the body, but if we take a plane coil CC (Fig. 344) the problem becomes much simpler.

The magnetic flux passing through the coil at any instant is $AH \sin pt$, where pt is the angle between H and the plane of the coil, and A the area of the coil. The electromotive force in the coil is given by the equation—

$$e = - \frac{dN}{dt}$$

$$\therefore e = - \frac{d}{dt} (AH \sin pt)$$

$$= -AH\rho \cos pt = AH\rho \sin \left(pt - \frac{\pi}{2} \right).$$

The current in the coil is therefore—

$$i = \frac{AH\rho}{\sqrt{l^2\rho^2 + r^2}} \sin \left(pt - \frac{\pi}{2} - a \right) \text{ (see p. 345),}$$

where l and r are the inductance and resistance of the coil and $\tan a = \frac{l\rho}{r}$.

The magnetic moment of the coil is Λi (see p. 225), and is perpendicular to its plane, being directed along the normal in direction MO . The couple acting on the coil, tending to turn it into the direction of H , is then—

$$- \Lambda i H \cos pt = - \frac{A^2 H^2 \rho}{\sqrt{l^2 \rho^2 + r^2}} \sin \left(pt - \frac{\pi}{2} - a \right) \cos pt$$

$$= - \frac{A^2 H^2 \rho}{\sqrt{l^2 \rho^2 + r^2}} \left\{ \sin pt \cos pt \cos \left(\frac{\pi}{2} + a \right) - \cos^2 pt \sin \left(\frac{\pi}{2} + a \right) \right\}.$$

We have seen that the mean value of $\sin pt \cos pt$, or $\sin 2pt$, for a cycle is zero, while that of $\sin^2 pt$ or $\cos^2 pt$ is $\frac{1}{2}$.

Therefore mean couple c is given by—

$$c = \frac{\Lambda^2 H^2 p}{2\sqrt{l^2 p^2 + r^2}} \sin\left(\frac{\pi}{2} + \alpha\right) = \frac{\Lambda^2 H^2 p}{2\sqrt{l^2 p^2 + r^2}} \cos \alpha$$

But, $\tan \alpha = \frac{l p}{r}$,

$$\therefore \cos \alpha = \frac{r}{\sqrt{l^2 p^2 + r^2}}$$

and, $c = \frac{\Lambda^2 H^2 r p}{2(l^2 p^2 + r^2)}$.

The mean couple is in the direction of rotation of the field.

The average couple therefore depends on the value of p , and this is the relative angular velocity of the field with respect to the coil. It is evidently zero when $p = 0$, and again when p is infinite. If then the coil is mounted so that it can rotate, its angular velocity in the direction of rotation of the field will increase until the rate at which work is done in opposition to friction of all kinds is equal to that done by the rotating field. On releasing the coil its angular velocity will increase at first, and as a result p , the relative angular velocity of the field with respect to the coil, diminishes and the couple still further increases; but the speed will never be equal to that of the field since in this case p would be zero and the couple would vanish. The average couple is a maximum when p has some value between zero and infinity.

To find the value of p for the average couple to be a maximum, find the condition that the rate of change of the average couple with respect to p shall be zero; *i.e.* let—

$$\frac{dc}{dp} = 0.$$

Now, $c = \frac{\Lambda^2 H^2 r p}{2(l^2 p^2 + r^2)}$,

$$\begin{aligned} \therefore \frac{dc}{dp} &= \frac{\Lambda^2 H^2 r}{2} \frac{d}{dp} \left(\frac{p}{l^2 p^2 + r^2} \right) \\ &= \Lambda^2 H^2 r \frac{l^2 p^2 + r^2 - 2l^2 p^2}{2(l^2 p^2 + r^2)^2}, \end{aligned}$$

and putting this equal to zero we have—

$$l^2 p^2 = r^2,$$

and, $p = \frac{r}{l}$.

Again, $\tan \alpha = \frac{l p}{r}$, so that the value of α for maximum couple is

$\tan^{-1} 1 = 45^\circ$, and the value of the couple under these circumstances is, since $p = \frac{l}{r}$ —

$$c = \frac{A^2 H^2 r \cdot r}{4r'l} = \frac{A^2 H^2}{4l}$$

This does not mean that the couple is independent of the resistance, which would obviously be incorrect, but merely gives the value of the couple when the condition $lp = r$ is fulfilled.

That this condition corresponds to a maximum couple may be proved by obtaining $\frac{d^2c}{dp^2}$ and showing that $\frac{dc}{dp}$ is decreasing when $lp = r$.

The quantity $l^2 p^2 + r^2$ has been plotted as ordinate in Fig. 345

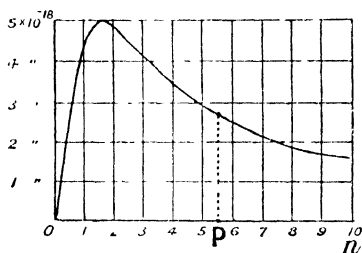

FIG. 345.

for a case in which $R = 1$ ohm or $r = 10^9$ absolute units and $L = 0.1$ henry = 10^8 absolute units. The frequency of alternation, n , has been taken as abscissa, the value of p being $2\pi n$. The relation

$$\frac{r}{l} = p = 2\pi n$$

gives the maximum couple at the frequency $n = \frac{10}{2\pi} = 1.59$, and it

will be seen that the quantity has the value 5×10^{18} at this frequency, and the average couple is $A^2 H^2 \times 5 \times 10^{-9}$. Now H may in a practical case be, say, 1000, and if the coil have an effective area of, say, 10,000 sq. cms.—

$$\begin{aligned} \text{maximum average couple} &= 10^8 \times 10^9 \times 5 \times 10^{-9} \\ &= 5 \times 10^8 \text{ C.G.S. units.} \end{aligned}$$

It should be noticed that the maximum occurs very near the axis of zero frequency, and from this maximum the couple falls gradually as the angular velocity of the field relatively to the coil increases.

The motion of a conductor in a rotating magnetic field has been put to many uses, the most notable of which is the construction of electro-motors in which two electromagnets are traversed by alternating currents of different phases. A mass of metal or a system of closed coils is mounted upon an axle in the rotating field, and experiences a driving couple as explained above.

If a conductor or coil E be mounted between two pairs of magnets

AB and CD (Fig. 346) carrying alternating currents differing in phase, the resulting magnetic field at E is a rotating field, and the conductor rotates. The magnets A and B may with advantage be combined to form one field magnet, as also may C and D, but they are represented as separate magnets in the diagram for the sake of clearness.

If the alternating currents in the two circuits are derived from the same supply, the currents in the two pairs of magnets will not differ in phase unless the time constants of the two circuits differ. To make the time constants differ, an extra inductance l may be introduced into the CD circuit, or a capacity into the circuit AB, or both.

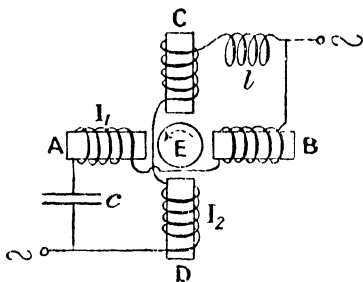

FIG. 346.

Thus,
and,

$$I_1 = I_1 \sin(\rho t + \theta_1)$$

$$I_2 = I_2 \sin(\rho t - \theta_2).$$

If I_1 and I_2 are equal and the magnets similar, then the magnetic field is a simple rotating field, when —

$$\theta_1 + \theta_2 = \frac{\pi}{2}.$$

In using motors of this type, the supply usually consists of two separate currents carried by two distinct circuits, the currents differing in phase by 90° . Such motors having circuits with alternating currents in different phases are called polyphase motors, and have the great convenience that they will start under load.

Single-Phase Motor.—A single alternating magnetic field may be looked upon as the resultant of two equal fields rotating with equal angular velocities in opposite directions. If the two coincide when in the direction Oy (Fig. 347) then, when one of them (OA) makes angle ρt with Ox the inclination of the other (OB) to Ox is $\pi - \rho t$. Thus the components parallel to Ox , are $H_0 \cos \rho t$ and $-H_0 \cos \rho t$, and these always annul each other; while the components parallel to Oy are $H_0 \sin \rho t$ and $H_0 \sin(\pi - \rho t)$, and these added together give the alternating field $2H_0 \sin \rho t$. A mass of metal or coil of wire mounted in

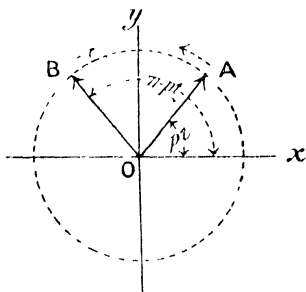

FIG. 347.

the field so that it can rotate, will experience equal and opposite couples due to the oppositely rotating components of the field, and it will therefore remain at rest.

Let the angular velocity of the fields with respect to the coil be represented by the value P on the curve (Fig. 345), and it will be seen that if the coil be given an angular velocity p_1 in one direction or the other, the relative angular velocity of one of the components of the field with respect to the coil will become $P - p_1$ and the other $P + p_1$. The couple produced by the former is therefore, as will be seen from the curve, greater than that for the latter, and the coil will gain velocity. The couple due to the driving component thus increases and the other diminishes until the mechanical work done on account of rotation prevents further increase in velocity.

The coil will therefore run as a motor in the direction in which it is given a start, but owing to the smallness of the resulting couple until the angular velocity approaches that of the driving component of the field, such a motor will not start under load. Hence such motors are provided with a second magnetising coil with some such device as that described on p. 375, for producing a difference of phase between the currents in the two coils. A single rotating magnetic field is therefore created, and the motor starts. When running at sufficient speed, the second or starting circuit is cut out and the motor continues to run as a single-phase machine.

Imaginary Quantities.—The usefulness of the exponential forms of the sine and cosine has already been seen (p. 334), and we will now make a further application of them to the problems of alternating currents. Let us consider the imaginary quantity $\sqrt{-b^2}$. This has no real value, but may be defined as the quantity whose square is equal to $-b^2$. Writing it in the form $\sqrt{-1} b$, or jb , where $j = \sqrt{-1}$, we can see that $j = \sqrt{-1}$, $j' = -1$, $j^2 = -\sqrt{-1}$, $j^3 = 1$, etc.

If we multiply any vector, say A , by j^2 , we obtain $j^2 A = -A$. Thus the sign is reversed, which is equivalent to a reversal in direction of the vector, or a rotation of its direction through 180° . Multiplying again by j^2 or -1 , it again becomes $+A$, and has therefore been rotated through a further 180° . From this we see that j^2 may be looked upon as an operator, the effect of which is to rotate any vector upon which it operates, through 180° . Similarly, j rotates it through 90° , j^3 through 270° , etc.

Any quantity whatever may be written in the form $a + jb$, where a is a real quantity and jb imaginary, and, further, if any equation involves both real and imaginary quantities, the sum of the real quantities is zero, and likewise that of the imaginaries.

Thus, if

$$\begin{aligned} a + jb &= a' + j b', \\ \text{then,} \quad a - a' &= j(b' - b), \end{aligned}$$

which cannot be true unless $a - a' = 0$, and $b' - b = 0$, for otherwise we should have a real quantity equal to an imaginary.

If a and b are vectors in the same direction, jb and a are vectors at right angles to each other, and the position of any point P (Fig. 348) may be represented by the vector $a + jb$, since $OQ = a$ and $QP = jb$.

∴ vector $OP = a + jb$.

Again, if $OP = r$, and angle $QOP = \theta$,
vector $OP = r(\cos \theta + j \sin \theta)$.

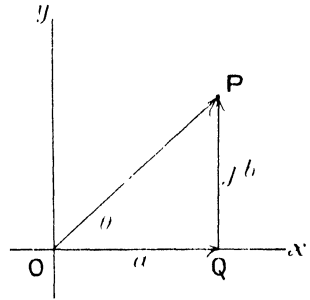

FIG. 348.

r is usually called the modulus and θ the argument of the complex quantity represented by the vector OP . From Fig. 348 we see that $r^2 = a^2 + b^2$ and $\tan \theta = \frac{b}{a}$, and hence the modulus and argument of any imaginary quantity of the form $a + jb$ are known.

Rotating Vector.—The exponential forms for $\sin \theta$ and $\cos \theta$ are $\frac{e^{j\theta} - e^{-j\theta}}{2j}$

and $\frac{e^{j\theta} + e^{-j\theta}}{2}$ respectively, and employing these forms, the quantity $r \cos \theta + j \sin \theta$ becomes $r e^{j\theta}$, and $r(\cos \theta - j \sin \theta)$ becomes $r e^{-j\theta}$

If, then, the vector OP , or r , rotates with angular velocity ω , and t be the interval of time since it coincided with Ox , $\theta = \omega t$, and $r(\cos \omega t + j \sin \omega t) = r e^{j\omega t}$. Now, $r \cos \omega t$ is the projection of r upon the axis of x at any instant, and is a quantity which varies harmonically, it is also the real part of the complex quantity $r e^{j\omega t}$. Similarly, $r \sin \omega t$ is the projection upon the axis Oy . The real part of $r e^{j\omega t}$ is therefore a harmonic motion taking place in the direction of the axis of x , and the imaginary part a similar harmonic motion, a quarter of a period later, in the axis of y .

Application of Imaginaries to Circuit having Inductance, Capacity, and Resistance.—The alternating electromotive force $E_0 \cos \omega t$ may be looked upon as the real part of the quantity $E_0 e^{j\omega t}$, or the projection upon the axis of x , of this rotating vector. The equation of electromotive forces (p. 353) may therefore be written—

$$L \frac{dI}{dt} + RI + \frac{Q}{C} = E_0 e^{j\omega t} \dots \dots \dots (i)$$

Now consider a solution, $I = A e^{j\omega t}$, which has evidently the same periodicity as the electromotive force. We must find the nature of the quantity A .

$$\frac{dI}{dt} = j\omega A e^{j\omega t}, \text{ and, } Q = \int I dt = \frac{A}{j\omega} e^{j\omega t} + \text{const.}$$

The constant in the last expression must be zero, since we are dealing entirely with harmonic changes;

$$\therefore Q = \frac{\Lambda}{jP} \epsilon^{jpt} = -\frac{j\Lambda}{P} \epsilon^{jpt}.$$

Equation (i) then becomes, on substitution—

$$I_p j \Lambda \epsilon^{jpt} + R \Lambda \epsilon^{jpt} - \frac{j\Lambda}{C_p} \epsilon^{jpt} = E_0 \epsilon^{jpt},$$

or,

$$\Lambda = \frac{E_0}{\left(I_p - \frac{1}{C_p}\right)j + R}.$$

Multiplying the numerator and denominator by $\left\{R - \left(I_p - \frac{1}{C_p}\right)j\right\}$,

$$\Lambda = \frac{E_0 \left\{R - \left(I_p - \frac{1}{C_p}\right)j\right\}}{\left(I_p - \frac{1}{C_p}\right)^2 + R^2},$$

which is of the form $a + jb$, where

$$a = \frac{E_0 R}{\left(I_p - \frac{1}{C_p}\right)^2 + R^2}, \quad \text{and} \quad b = \frac{E_0 \left(I_p - \frac{1}{C_p}\right)}{\left(I_p - \frac{1}{C_p}\right)^2 + R^2}.$$

Hence the modulus is

$$\sqrt{a^2 + b^2} = \frac{E_0}{\sqrt{\left(I_p - \frac{1}{C_p}\right)^2 + R^2}}.$$

and the argument is

$$\theta = \tan^{-1} \frac{b}{a} = \tan^{-1} \frac{I_p - \frac{1}{C_p}}{R},$$

$$\therefore \Lambda = \frac{R_0}{\sqrt{\left(I_p - \frac{1}{C_p}\right)^2 + R^2}} \epsilon^{-j\theta}$$

And the solution to our equation is,

$$\mathbf{I} = \frac{E_0}{\sqrt{\left(I_p - \frac{1}{C_p}\right)^2 + R^2}} \epsilon^{j(pt - \theta)}$$

The real part of this is the harmonic current required, and will be seen to be in agreement with the solution obtained on p. 354.

Comparison of Inductances.—From the above, we see that $L \frac{dI}{dt} = L_j p \Lambda \epsilon^{jpt} = I_j p L$, and $\frac{Q}{C} = \frac{1}{C} \int I dt = \frac{\Lambda}{j C p} \epsilon^{jpt} = -\frac{j}{C p} I$, and hence the electromotive force equation may be written—

$$\left(L_j p + R - \frac{j}{C p} \right) I = E_0 \epsilon^{jpt}.$$

This is of convenience in solving many problems. Referring to the method of comparing inductances on p. 324 (Fig. 314), we see that for no current to flow in the galvanometer, we have the current I_1 in BAD and I_2 in BCD, and the electromotive force in both branches is the same. If, then, the battery be replaced by a source of alternating current,

$$\text{For branch BAD,} \quad I_1 \frac{dI_1}{dt} + P I_1 + Q I_1 = E,$$

$$\text{and for branch BCD,} \quad I_2 \frac{dI_2}{dt} + R I_2 + S I_2 = E.$$

Therefore for simple harmonic E.M.F.'s and currents,

$$\{L_1 p j + (P + Q)\} I_1 = \{L_2 p j + (R + S)\} I_2.$$

But the real parts and the imaginary parts must separately vanish (see p. 376);

$$\therefore L_1 p I_1 = L_2 p I_2, \text{ and } (P + Q) I_1 = (R + S) I_2,$$

$$\therefore \frac{I_1}{I_2} = \frac{P + Q}{R + S} = \frac{P}{R} = \frac{Q}{S}.$$

An ordinary galvanometer will, of course, be useless when alternating currents are employed, and may be replaced by a telephone receiver, the resistances being adjusted until the sound in the telephone ceases.

Comparison of Capacities.—Referring to p. 325 (Fig. 315), we may, on joining an alternating source of supply to B and D, and replacing the galvanometer by a telephone, obtain silence when

$$\left(R_1 I_1 + \frac{Q_1}{C_1} \right) = \left(R_2 I_2 + \frac{Q_2}{C_2} \right) = E_0 \epsilon^{jpt}$$

or since $Q_1 = f I_1 dt$, etc.,

$$\left(R_1 - \frac{j}{C_1 p} \right) I_1 = \left(R_2 - \frac{j}{C_2 p} \right) I_2$$

$$\therefore \frac{I_1}{C_1 p} = \frac{I_2}{C_2 p}, \text{ and } R_1 I_1 = R_2 I_2,$$

$$\therefore \frac{C_1}{C_2} = \frac{R_2}{R_1}.$$

Vibration Galvanometer.—In order to avoid the use of a telephone, Mr. Campbell¹ has employed a galvanometer in which a very light coil has a bifilar suspension, in which the tension can be varied by altering the pull on the suspension. The vibration frequency of the suspended coil can thus be varied (from 50 ~ to 1000 ~), and may be tuned to coincide with the frequency of the alternating current employed. Thus a feeble current in the galvanometer may, owing to resonance, produce a large vibration in the galvanometer coil, and great sensitiveness may be attained. Campbell also describes a number of methods of comparing capacities, inductances, and resistance by means of the vibration galvanometer.

Comparison of Capacity and Mutual Inductance.—Campbell

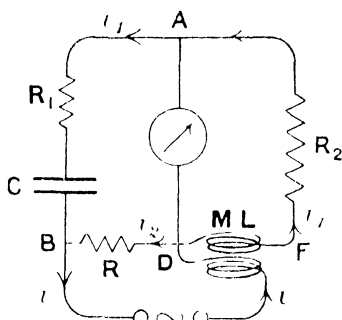

FIG. 349.

gives the following method for the measurement of capacity in terms of a mutual inductance. Let C be the capacity, and ML (Fig. 349) be the mutual inductance, of which the coil in the circuit between D and F has inductance L , the arrangement being as shown in the figure. Since there is to be no current in the galvanometer, we have for the circuit AFD ,

$$L \frac{di_1}{dt} - M \frac{di}{dt} + R_2 i_1 = 0.$$

Now, for the point D , $i = i_1 + i_2$,

$$\therefore L \frac{di_1}{dt} - M \frac{di_1}{dt} + R_2 i_1 = M \frac{di_2}{dt}.$$

Again, for circuit DBA , since D and A are always at the same potential, $\frac{q}{C} = R_1 i_2 - R_1 i_1$, where $q = \int i_1 dt$, the charge upon the condenser,

$$\therefore \frac{\int i_1 dt}{C} = R_1 i_2 - R_1 i_1,$$

$$\text{or, } R_1 \frac{di_1}{dt} + \frac{i_1}{C} = R_1 \frac{di_2}{dt},$$

substituting this value of $\frac{di_2}{dt}$ in the above,

$$L \frac{di_1}{dt} - M \frac{di_1}{dt} + R_2 i_1 = \frac{M}{R} \left(R_1 \frac{di_1}{dt} + \frac{i_1}{C} \right),$$

$$\text{or } \left(L - M - M \frac{R_1}{R} \right) \frac{di_1}{dt} + \left(R_2 - \frac{M}{RC} \right) i_1 = 0,$$

¹ Albert Campbell, *Proc. Phys. Soc. Lond.*, 20, p. 626. 1907.

and since the electromotive force is simple harmonic, the current equation may be written in terms of symbolic operators, thus,

$$\left(L - M - M \frac{R_1}{R} \right) p i_1 + \left(R_2 - \frac{M}{RC} \right) i_1 = 0,$$

and therefore $L - M - M \frac{R_1}{R} = 0$, and, $R_2 - \frac{M}{RC} = 0$,

$$\frac{L}{M} = \frac{R + R_1}{R}, \text{ and, } \frac{M}{C} = RR_2$$

On adjusting the resistances until there is no current in the galvanometer or telephone, the relations between the inductances and capacity are known in terms of the resistances.

CHAPTER XIII

UNITS

Dimensions.—Throughout the whole range of Physics we are concerned with the magnitudes of various quantities and their relations to each other, and it therefore becomes of importance to examine certain laws which underlie these relationships. The most fundamental relationship is that of mere number; quantities may be added to each other provided that they are all of one kind, but not if they are of different kinds. We see therefore that all the terms that are to be added together in any equation must be of one kind, and if their nature is for any purpose changed, all the terms must change in the same manner and at the same stage of the calculation.

In order to define any physical quantity, two statements are necessary; we must know the unit in which the quantity is measured, and the numeric relation between the quantity and the unit. The latter is a mere number or ratio, which tells us the relative magnitudes of the quantity and the unit, while the former gives us information with respect to the nature of the quantity.

We therefore require as many different kinds of unit as there are physical quantities to be measured, but the units need not necessarily be independent of each other. Before the importance of devising a scientific system of units was realised, it was customary to fix a new arbitrary unit for every fresh quantity to be measured, quite irrespectively of its relation to the units already in existence, and sometimes many units for the same quantity, as may easily be realised by contemplating the number of different units of volume there are in use in this country at the present time.

The attempt is always made in scientific work to have as few arbitrary units as possible, and to choose those units to be of as durable and easily copiable a form as possible. The fundamental units chosen are those of mass, length, and time. The unit of mass is one-thousandth part of the mass of a piece of platinum kept in the Archives de Paris, and is called the gramme; the unit of length is one-hundredth of the distance between two marks on a platinum bar at the standard temperature, also kept at the Archives de Paris, and is called the centimetre; and the unit of time is called the second. It is $\frac{1}{86400}$ of

the average interval between two successive transits of the sun across a given meridian.

Most physical units may be explicitly defined in terms of these three, raised to various powers; and the powers to which they must be raised to obtain any derived unit are called the *dimensions* of that unit. Thus the unit of volume is that of a cube whose edge is one centimetre, or writing [L] for the unit of length and [V] for the unit of volume—

$$[V] = [L^3],$$

is the dimensional equation corresponding to the above statement. It tells us that a volume is of the third dimension in length.

Or again, the unit of velocity is such that the body moves through a distance of one centimetre in one second, which fact written as a dimensional equation is—

$$[\text{Velocity}] = \left[\frac{L}{T} \right] = [LT^{-1}].$$

In a similar manner we may see that—

$$\begin{aligned} [\text{Acceleration}] &= [LT^{-2}], \\ [\text{Force}] &= [MLT^{-2}], \\ [\text{Pressure}] &= [ML^{-1}T^{-2}], \\ [\text{Energy}] &= [F \cdot L] = [ML^2T^{-2}], \\ [\text{Moment of inertia}] &= [ML^2], \\ [\text{Density}] &= [ML^{-3}], \\ [\text{Angle}] &= [L_x \cdot L_y^{-1}] = [L^0]. \end{aligned}$$

An angle is of no dimensions, that is, it is a mere ratio of two lengths. These two lengths are, however, measured in different directions, and if it is desired to retain them in the dimensional equation they may be written L_x and L_y , in which case the equation becomes—

$$[\text{angle}] = [L_x L_y^{-1}]$$

In the same way—

$$[\text{couple}] = [ML_x L_y T^{-2}].$$

Knowing the units in which any quantity is to be measured, it only remains to state the numeric defining the ratio of the magnitude of the quantity to that of the unit, in order to define completely the quantity. Thus if we state that a force is $12[MLT^{-2}]$ we mean that the force is 12 units, or 12 times the force that would produce unit acceleration in unit mass. Or again, if we say that a density is $3[ML^{-3}]$ we mean that it is 3 times the unit density, that is three times the density of a substance in which there is one unit of matter in unit volume.

On the centimetre-gramme-second (C.G.S.) system, some of these derived units have particular names. Thus the unit of force is called the dyne, and the unit of work the erg.

Uses of Theory of Dimensions.—A consideration of the dimensions of the terms in a given equation frequently serves as a useful check upon the accuracy of the calculations by which the equation was obtained, since all the terms that are added in a given expression must be of the same kind, and therefore of the same dimensions.

Thus in the equation $v^2 = u^2 - 2ugt \sin a + g^2 t^2$, for the velocity of a body projected with velocity u at an angle a to the horizon,

$$\begin{aligned} [v^2] &= [L^2 T^{-2}], \quad [u^2] = [L^2 T^{-2}], \\ [2ugt \sin a] &= [L T^{-1} \cdot L T^{-2} \cdot T] = [L^2 T^{-2}], \\ \text{and,} \quad [g^2 t^2] &= [L^2 T^{-4} \cdot T^2] = [L^2 T^{-2}], \end{aligned}$$

and we see that every term has the same dimensions. If this were not the case we should be sure of the existence of some error in the equation.

Another use to which a knowledge of dimensions may be put, is the solving of certain physical problems, thus—

Given that the difference of pressure, p , between the gas inside and outside of a soap-bubble depends only on the surface tension of the film and its radius of curvature, to find how these quantities enter into the expression for p .

The dimensional equation is $[p] = [t^x R^y]$, where x is the unknown power to which the surface tension t is to be raised, and similarly y is the unknown power of R , the radius of curvature.

Now, from p. 383, $[p] = [M L^{-1} T^{-2}]$, and t is a force per unit length, therefore $[t] = [M L^0 T^{-2}] = [M T^{-2}]$, and $[R] = [L]$.

$$\begin{aligned} \therefore [M L^{-1} T^{-2}] &= [M T^{-2}]^x [L]^y, \\ &= [M^x L^y T^{-2x}]. \end{aligned}$$

Since these two expressions must be of the same kind—

$$\begin{aligned} x &= 1, \text{ and, } y = -1, \\ \therefore [p] &= [t R^{-1}], \end{aligned}$$

that is, the pressure varies directly as the surface tension and inversely as the radius of curvature.

Again, if we are given that the velocity of a compression wave in air depends only on the pressure and density of the air,

$$\begin{aligned} [V] &= [P^x D^y] = [M L^{-1} T^{-2}]^x [M L^{-3}]^y, \\ [L T^{-1}] &= [M^{x+y} L^{-x-3y} T^{-2x}]. \end{aligned}$$

And again, since these quantities must be of the same kind—

$$x + y = 0, \quad -x - 3y = 1, \text{ and, } -2x = -1,$$

from any two of which equations we have—

$$x = \frac{1}{2}, \text{ and, } y = -\frac{1}{2},$$

$$\therefore [V] = [P^1 D^{-1}] = \left[\sqrt{\frac{P}{D}} \right].$$

A treatment of this kind will never give us the numerical relation between the quantities considered, as their magnitude has deliberately been excluded from the equations.

A third problem will now be considered, in which the method will not lead us to any useful information. Given that the gravitational force between two bodies depends on their masses and distance apart, we have—

$$[F] = [M^x \cdot M^y \cdot D^z],$$

$$[MLT^{-2}] = [M^{x+y} L^z T^0],$$

from which $x + y = 1$ and $z = 1$, and, further, we come to the absurd statement that $-2 = 0$. The reason for the breakdown in our method does not lie in any imperfection in the method itself, but in the fact that we do not know, and have not represented in our equation, the whole of the process occurring in the problem. The mechanism by means of which the two bodies attract each other is unknown, but should not on that account be omitted from the equation. We can obtain information about this mechanism if we establish the law of force between two masses to be $G \frac{m_1 m_2}{d^2}$, and then from our dimensional equation find the nature of the quantity G .

Thus,

$$[MLT^{-2}] = [G \cdot M^2 L^{-2}],$$

$$[G] = [M^{-1} L^2 T^{-2}].$$

Owing to our ignorance of the mechanism of gravitation, the dimensions of G , the “constant” of gravitation, are unintelligible, as, for example, we can attach no meaning to M^{-1} , the inverse of a mass; but should we obtain knowledge which will enable us to express G in terms of some other effects, this unintelligibility will doubtless disappear.

Electrical Units.—We are met by the difficulty discussed in the last paragraph, directly we attempt to find the dimensions of any electrical quantity in terms of mass, length, and time. The dimensional equation for the force between two magnetic poles may be written—

$$[MLT^{-2}] = \left[\frac{m^2}{L^2} \right],$$

$$[m] = [M^{\frac{1}{2}} L^{\frac{1}{2}} T^{-1}].$$

We can attach no meaning to the quantities $[M^{\frac{1}{2}}]$ and $[L^{\frac{1}{2}}]$, and their presence in the dimensional equation is due to our omission to take into account the mechanism by means of which the attraction takes place. The medium in which the poles are situated plays an important

part in determining the force between them, and it is a step in advance to include the property of the medium, known as its permeability (p. 233), in the dimensional equation.

$$\begin{aligned} \text{Thus,} \quad [MLT^{-2}] &= \left[\frac{m^2}{\mu I^2} \right], \\ \therefore [m] &= [M^{\frac{1}{2}} L^{\frac{1}{2}} T^{-1} \mu^{\frac{1}{2}}]. \end{aligned}$$

It is quite possible that if the dimensions of μ could be put into the equation, they would rationalise the terms in M and L.

An exactly similar argument leads to the dimensions of an electric charge—

$$[q] = [M^{\frac{1}{2}} L^{\frac{3}{2}} T^{-1} k^{\frac{1}{2}}],$$

where $[k]$ is the unit of dielectric constant.

It is usual to consider, for practical purposes that empty space has unit magnetic permeability and dielectric constant, but it should be noted that these units are really arbitrary, and until we know more about the properties of the luminiferous ether we cannot say what their absolute dimensions may be.

Starting with our definition of unit pole on one hand (p. 2), we have built up a system of units for electrical and magnetic quantities, all of which involve the dimensions of μ , which is called the *Electromagnetic System*, and with the definition of unit electrical charge (p. 116), on the other hand, the resulting system on which all the quantities involve the dimensions of k is called the *Electrostatic System*. Both of these are absolute systems, by which is meant that the magnitudes of the units are derived directly from the centimetre, the gramme, and the second, μ and k being taken to be numerically equal to unity.

Electromagnetic System of Units. Starting with the magnetic pole as defined above, whose dimensions are $[M^{\frac{1}{2}} L^{-\frac{1}{2}} T^{-1} \mu^{\frac{1}{2}}]$, we can derive the others from this.

Strength of Field—Since force on magnetic pole is the product of strength of field and strength of pole (p. 3)—

$$\begin{aligned} F &= Hm, \\ \therefore [MLT^{-2}] &= [H][M^{\frac{1}{2}} L^{\frac{1}{2}} T^{-1} \mu^{\frac{1}{2}}], \end{aligned}$$

whence,

$$[H] = [M^{\frac{1}{2}} L^{-\frac{1}{2}} T^{-1} \mu^{-\frac{1}{2}}].$$

This unit of magnetic field is called the *Gauss*. It is a field of such strength that a unit pole situated in it experiences a force of one dyne.

Magnetic Induction.—The magnetic induction is defined on p. 234 as the quantity μH , and its dimensions are therefore $[M^{\frac{1}{2}} L^{-\frac{1}{2}} T^{-1} \mu^{\frac{1}{2}}]$.

The relation $B = H + 4\pi I$ given on p. 268 appears at first sight to contain terms of different dimensions; but this is the result of taking the permeability of air to be unity, in which case the relation $B = \mu H$

reduces to $B = H$. If the permeability of air be written μ_0 , the equation is then—

$$\mu H = \mu_0 H + 4\pi I$$

in which each term has the same dimensions.

Magnetic Flux (Bs).—The dimensions immediately follow from those of magnetic induction since $[s] = [L^2]$; they are,

$$[M^1 L^2 T^{-1} \mu^{-1}]$$

The unit on the C.G.S. system is called the *Maxwell*.

Magnetic Moment.—This may be obtained from the definition, pole strength \times length, or from the couple exerted on the magnet situated in a field (p. 5). Either definition leads to the quantity—

$$[M^1 L T^{-1} \mu^{-1}]$$

Intensity of Magnetisation is magnetic moment per unit volume —

$$[M^1 L^{-1} T^{-1} \mu^{-1}]$$

Electric Current.—From the relation between current and magnetic field (p. 53)

$$\begin{aligned} H &= \frac{idl \sin \theta}{r^2} \\ [i] &= [M^1 L^{-1} T^{-1} \mu^{-1} L] \\ &= [M^1 L^1 T^{-1} \mu^{-1}] \end{aligned}$$

since $\sin \theta$ is of zero dimensions. Or from the equivalence between a current and a magnetic shell (p. 237), we have for the strength of shell μi , the magnetic moment per unit area —

$$\begin{aligned} \therefore [\mu i] &= [M^1 L^1 T^{-1} \mu^{-1} L^{-2}] \\ &= [M^1 L^1 T^{-1} \mu^{-1}] \\ [i] &= [M^1 L^1 T^{-1} \mu^{-1}] \end{aligned}$$

Quantity of Electricity.—Since $i = \frac{q}{t}$, or $q = it$ (p. 121)

$$[q] = [M^1 L^1 \mu^{-1}]$$

Electromotive Force.—(e) The rate of working in units of work per second is equal to the product of current and electromotive force (p. 59)

$$\begin{aligned} [M^1 L^1 T^{-1} \mu^{-1} \cdot T^{-1} \mu^{-1} \cdot e] &= [ML^2 T^{-3}] \\ \therefore [e] &= [M^1 L^1 T^{-2} \mu^{-1}] \end{aligned}$$

Electric Intensity.—From the relation $e = fEdl$ (p. 120), we have—

$$[E] = [M^{\frac{1}{2}}L^{\frac{1}{2}}T^{-2}\mu^{\frac{1}{2}}].$$

Resistance.—The ohmic relation between electromotive force and current (p. 60) gives

$$[r] = \frac{[e]}{[i]} = [IT^{-1}\mu].$$

Neglecting the dimensions of μ , resistance is seen to be of the dimensions of a velocity, and for this reason it is sometimes spoken of as so many centimetres per second.

Capacity.—From the equation $c = \frac{q}{e}$ (p. 150) we obtain—

$$[c] = [L^{-1}T^2\mu^{-1}].$$

Inductance.—Using the relation $e = -l \frac{di}{dt}$, or $e = -m \frac{di}{dt}$ (p. 313), we see the dimensions of inductance, either self or mutual, to be—

$$\frac{[M^{\frac{1}{2}}L^{\frac{3}{2}}T^{-2}\mu^{\frac{1}{2}}][T]}{[M^{\frac{1}{2}}L^{\frac{1}{2}}T^{-1}\mu^{-\frac{1}{2}}]} = [I\mu].$$

Again neglecting the dimensions of μ , an inductance may be measured in centimetres.

Electrostatic System of Units.—Beginning with the unit of electrical charge, $[q] = [M^{\frac{1}{2}}L^{\frac{3}{2}}T^{-1}k^{\frac{1}{2}}]$, as defined on p. 386, we may obtain the other electrical and magnetic units in terms of this.

Potential Difference.—As defined on p. 120, we have—

$$\begin{aligned} \text{p.d.} \times \text{charge} &= \text{work}, \\ \therefore [e \ q] &= [ML^2T^{-2}], \end{aligned}$$

from which,

$$\begin{aligned} [e] &= \frac{[ML^2T^{-2}]}{[M^{\frac{1}{2}}L^{\frac{3}{2}}T^{-1}k^{\frac{1}{2}}]}, \\ &= [M^{\frac{1}{2}}L^{\frac{1}{2}}T^{-1}k^{-\frac{1}{2}}]. \end{aligned}$$

Electric Intensity.—Since force on a charge is equal to product of charge and electric intensity (p. 117)—

$$\begin{aligned} [Eq] &= [MLT^{-2}], \\ \therefore [E] &= [M^{\frac{1}{2}}L^{-\frac{1}{2}}T^{-1}k^{-\frac{1}{2}}]. \end{aligned}$$

Electrical Induction, Displacement, or Surface Density.—From the definition on p. 130, this is equal to kE .

$$\therefore [\sigma] = [N] = [D] = [M^{\frac{1}{2}}L^{-\frac{1}{2}}T^{-1}k^{\frac{1}{2}}].$$

Electric Current.—The rate at which electric charge passes along a conductor is the current.

$$\therefore [i] = \frac{[q]}{[T]} = [M^{\frac{1}{2}}L^{\frac{3}{2}}T^{-2}k^{\frac{1}{2}}].$$

Resistance.—As on p. 388 —

$$[r] = \frac{[e]}{[i]};$$

$$\therefore [r] = \frac{[M^{\frac{1}{2}}L^{\frac{1}{2}}T^{-1}k^{-\frac{1}{2}}]}{[M^{\frac{1}{2}}L^{\frac{3}{2}}T^{-2}k^{\frac{1}{2}}]}$$

$$= [L^{-1}T^2k^{-1}].$$

Magnetic Field.—Using again the expression $\mathbf{H} = \frac{idl \sin \theta}{r^2}$, we have—

$$[H] = [M^{\frac{1}{2}}L^{\frac{1}{2}}T^{-2}k^{\frac{1}{2}}].$$

Magnetic Pole.—Since, force = mH —

$$[m] = [M^{\frac{1}{2}}L^{\frac{1}{2}}k^{-\frac{1}{2}}].$$

Capacity.—Since, $c = \frac{q}{e}$ —

$$[c] = \frac{[M^{\frac{1}{2}}L^{\frac{3}{2}}T^{-1}k^{\frac{1}{2}}]}{[M^{\frac{1}{2}}L^{\frac{1}{2}}T^{-1}k^{-\frac{1}{2}}]} = [Lk].$$

Inductance.—From the definition $e = -l \frac{di}{dt}$, or $e = -m \frac{di}{dt}$ —

$$[m]^1 = [l] = \frac{[M^{\frac{1}{2}}L^{\frac{1}{2}}T^{-1}k^{-\frac{1}{2}}][T]}{[M^{\frac{1}{2}}L^{\frac{1}{2}}T^{-2}k^{\frac{1}{2}}]} = [L^{-1}T^2k^{-1}].$$

Forces between Currents and Poles.—The equation for the magnetic field due to a current is the connecting link between the two electrical systems of units. This equation in any of its forms, namely that for the force on a magnetic pole at the centre of a circular coil, $\frac{2\pi nim}{r}$, or that on a pole within a solenoid $\frac{4\pi nim}{l}$, where n is the total number of turns and l the length, is always of the dimension $\left[\frac{im}{l}\right]$, and does not involve k or μ , except in so far as they are involved in the quantities i

¹ m is here mutual inductance, not magnetic pole.

and m . Hence we see that the force between a current and a magnetic pole is independent of the nature of the medium in which they are situated; a point which has already been met on p. 237. The force on the pole being equal to that on the current, we know that on immersing the two in a medium of permeability μ , the induction due to the pole is everywhere the same as before, and therefore the force on a current depends on the value of the induction at the point, and not the field; while on the other hand we have seen that the force on a pole depends on the field at the point, and not the induction.

If two poles be situated in space, the fields due to each are proportional to $\frac{m_1}{\mu}$ and $\frac{m_2}{\mu}$, and the force between them is proportional to $\frac{m_1 m_2}{\mu}$.

If a pole and a current are near each other, the field due to the current is proportional to i , and the force on the pole to mi . The field due to the pole is proportional to $\frac{m}{\mu}$, and the induction to $\mu \cdot \frac{m}{\mu} = m$, and the force on the current is therefore again proportional to mi .

Continuing the process, we may find the effect of the medium upon the force between two currents. The field due to one is proportional to i_1 , and the induction due to it to μi_1 , and hence the force on the other is proportional to $\mu i_1 i_2$. The effect of the medium is therefore to increase the force between the currents to μ times the force *in vacuo*.

Relation between Units on the Two Systems.—It is unreasonable to suppose that one and the same quantity can have two different dimensions with respect to mass, length, and time, and hence if we compare the dimensions of any of the above quantities on the two systems, it is extremely likely that the dimensions of μ and k will account for the apparent discrepancy in the dimensions of the fundamental units. Take, for example, electric current. On the electro-magnetic system $[i] = [M^{1/2} L^{1/2} T^{-1} \mu^{-1/2}]$, and on the electrostatic system $[i] = [M^{1/2} L^{-1/2} T^{-2} k^{1/2}]$, and since these are quantities of essentially the same kind we have—

$$[M^{1/2} L^{1/2} T^{-1} \mu^{-1/2}] = [M^{1/2} L^{-1/2} T^{-2} k^{1/2}],$$

whence,

$$[k^{1/2} \mu^{1/2}] = [L T^{-1}],$$

or,

$$\left[\frac{1}{\sqrt{k\mu}} \right] = [LT^{-1}].$$

Now $[LT^{-1}]$ is a velocity, and we are therefore led to the conclusion that $\frac{1}{\sqrt{k\mu}}$ has the dimensions of a velocity. By no possible choice of the above electrical and magnetic quantities to be compared, can we obtain the dimensions of k or μ separately; whichever quantity we

choose for our comparison, we come to the same conclusion, that $\frac{1}{\sqrt{k\mu}}$ is a velocity. By a measurement of the magnitudes of any electrical quantity on the two systems, we can obtain the magnitude of this quantity, and when this is carried out, the velocity appears to be about 3×10^{10} cms. per second, which is the velocity of light. This suggestive fact led Maxwell to conclude that light consists of an electromagnetic wave, and he eventually established the fact by means of equations relating to the electrical and magnetic condition of the luminiferous ether.

If i_e be the number of electrostatic units in a given current, the complete expression for the current is $i_e[M^{\frac{1}{2}}L^{\frac{1}{2}}T^{-\frac{1}{2}}k^{\frac{1}{2}}]$, and if i_m be the number of electromagnetic units in the same current, $i_m[M^{\frac{1}{2}}L^{\frac{1}{2}}T^{-1}\mu^{-\frac{1}{2}}]$ is its expression in electromagnetic measure, where i_e and i_m are mere numbers.

$$\therefore i_e[M^{\frac{1}{2}}L^{\frac{1}{2}}T^{-\frac{1}{2}}k^{\frac{1}{2}}] = i_m[M^{\frac{1}{2}}L^{\frac{1}{2}}T^{-1}\mu^{-\frac{1}{2}}],$$

or,
$$\left[\frac{1}{k^{\frac{1}{2}}\mu^{\frac{1}{2}}} \right] = \frac{i_e}{i_m} [LT^{-1}].$$

But i_e and i_m being the magnitudes of the same current in different units, their ratio is the inverse ratio of the size of the units,

$$\therefore \frac{i_e}{i_m} = \frac{\text{size of electromagnetic unit of current}}{\text{size of electrostatic unit of current}} = \text{say } v.$$

We see, then, that $\frac{1}{\sqrt{k\mu}} = v$ centimetres per second, since $[LT^{-1}]$ is a velocity of one centimetre per second.

The numerical value of v may be determined by measuring experimentally the same current in electrostatic and in electromagnetic measure. It is, however, more convenient to choose capacity for the subject of measurement, as the capacity of a condenser of simple form may be calculated in electrostatic measure from its dimensions, and it may be measured in electromagnetic measure by means of the ballistic galvanometer.

Let a given condenser have a capacity of c_e electrostatic units, or c_m electromagnetic units.

Then, as before,
$$c_e[Ik] = c_m[L^{-1}T^2\mu^{-1}],$$

or,
$$\left[\frac{1}{k\mu} \right] = \frac{c_e}{c_m} [L^2T^{-2}],$$

$$\left[\frac{1}{\sqrt{k\mu}} \right] = \sqrt{\frac{c_e}{c_m}} [LT^{-1}],$$

$$\therefore \frac{1}{\sqrt{k\mu}} = \sqrt{\frac{c_e}{c_m}} = v \text{ centimetres per second.}$$

A convenient form of condenser may be made by fixing layers of tinfoil upon two sheets of glass, one of the layers being circular, and surrounded by a circular guard ring, the other covering the whole sheet ; or from two pieces of silvered plate glass from which the paint on the

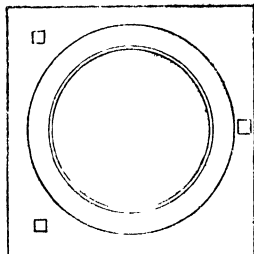

FIG. 350.

back of the silver has been removed by means of caustic soda, and a circular gap made in one of them by scraping away the silver. The two are placed with the metallic surfaces face to face and kept apart by three thin distance pieces of ebonite, the thickness of which, will give the distance apart of the plates of the condenser (t).

Then $c_s = \frac{A}{4\pi t}$, where A is the area of the circular plate, the larger plate being earthed. The dielectric constant of air is taken as unity.

To determine c_m , the plate and ring are charged to a high potential V ; then the ring is earthed, and the plate discharged through the ballistic galvanometer.

$$c_m V = \frac{cT}{2\pi n \Lambda H} \theta, \quad (\text{p. 254})$$

where θ is the ballistic throw. The galvanometer may be calibrated by producing a steady deflection θ_1 by means of a current produced by a known fraction of V , say $\frac{V}{n}$ and a high resistance r .

$$\frac{V \Lambda H}{n R} = c \theta_1,$$

$$\therefore c_m = \frac{T}{2\pi n R} \cdot \frac{\theta}{\theta_1}.$$

If the capacity is so small that an unreasonably high potential V is required to produce a readable ballistic throw, the capacity may be compared with that of a larger condenser by the method on p. 163, or in terms of a resistance and a frequency, by the method on p. 393.

The principle of this method was first employed by Professors Ayrton and Perry,¹ the condenser being charged by the fall of potential over a resistance of 10,000 ohms produced by a battery of 382 Daniell cells. To produce the steady current in the galvanometer, a known fraction of this was used, and a high resistance was placed in series with the galvanometer. The mean of their results, corrected for

¹ W. E. Ayrton and J. Perry, *Journal Soc. Tel. Eng.*, 8, p. 126. 1879.

the value of the B.A. ohm used by them, in terms of the international ohm is, $v = 2.995 \times 10^{10}$.

Maxwell's Method—If a condenser be placed in series with a battery and galvanometer, it will receive a charge ec , where e is the electromotive force of the battery, and c the capacity of the condenser. This is the state of affairs when the rocker D is in contact with A (Fig. 351). Then if D is moved over so that it makes contact with B instead of A, the condenser is discharged. On moving D back into contact with A the condenser receives another charge ec , and if this process be repeated n times per second, the total charge that has been drawn from the battery and which has passed through the galvanometer is nec . This is equivalent to a current, and if n is great in comparison with the frequency of vibration of the moving part of the galvanometer, a steady deflection will be obtained. The key may take the form of a revolving commutator or a suitably arranged tuning-fork of known frequency, in which case n is known.

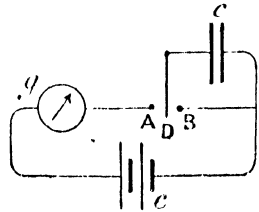

FIG. 351.

If the condenser and key be replaced by a conductor, and the whole resistance of the circuit adjusted until the deflection of galvanometer is the same as that with the condenser and key, the current

$$i = \frac{e}{r} = nec.$$

$$\therefore r = \frac{1}{nc}, \text{ or, } c = \frac{1}{rn}.$$

We see, therefore, that the intermittent charge and discharge has the same effect as a resistance, and if the frequency and the whole resistance of the circuit be known, c may be determined.

Since the capacity is therefore found in electromagnetic measure, and its value in electrostatic measure can be calculated from its dimensions, v can be found as before.

Maxwell pointed out¹ that the substitution of the resistance for the capacity and key is unnecessary if these are placed in one arm of the Wheatstone's bridge and a balance obtained in the ordinary way.

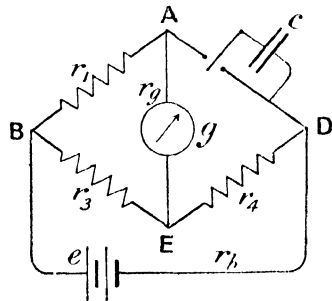

FIG. 352.

The arrangement is then as shown in Fig. 352. The resistances

¹ Maxwell, "Electricity and Magnetism," vol. ii §§ 775 and 776.

are adjusted until the galvanometer deflection is zero, when the approximate relation $\frac{1}{nc} \cdot r_3 = r_1 r_4$ holds. Since the method is usually employed for measuring very small capacities, r_1 is always very small. For example, a condenser of the type described on p. 392 would have a capacity of the order 10^{-22} absolute electromagnetic unit or 10^{-12} farad.

If, then, n is say 100, and r_1 and r_4 say 1,000,000 ohms each—

$$r_3 \cdot 10^{11} = 10^{12}$$

$$r_3 = 10 \text{ ohms.}$$

In a case such as this the relation between capacity and resistance may be established, by equating the values of the steady current in the galvanometer when the condenser circuit is permanently open, the value of which is $\frac{e}{r_b + r_4 + \frac{r_1(r_1 + r_2)}{r_1 + r_1 + r_2}} \frac{r_1}{r_3 + r_1 + r_2}$, where e is the electromotive force of the battery, to the charge per second passing through the galvanometer due to the intermittent charging of the condenser. The difference of potential between A and D is,

$$(r_1 \times \text{current in ED}) + (r_2 \times \text{current in } g)$$

$$= r_4 \frac{e}{P} + r_2 \frac{e}{P} \cdot \frac{r_1}{r_3 + r_1 + g} = \frac{e}{P} \left(r_4 + \frac{r_1 r_2}{r_3 + r_1 + r_2} \right),$$

where P is written for $\left\{ r_b + r_4 + \frac{r_1(r_1 + r_2)}{r_1 + r_1 + r_2} \right\}$, the resistance of the entire circuit exclusively of the branch AD. Hence charge on C when fully charged is —

$$\frac{ce}{P} \left(r_4 + \frac{r_1 r_2}{r_3 + r_1 + r_2} \right).$$

Now, owing to the smallness of the resistances r_1 and r_2 , the charge, when the condenser is closed, will flow round the circuit A(BE)ED, B and E being practically one point, owing to the smallness of r_1 . The charge divides between the paths AB and AEB, the fraction $\frac{r_1}{r_3 + r_1 + r_2}$ flowing by the path AEB, that is, through the galvanometer, the ratio being independent of the inductances of the branches (see p. 318). And since this discharge takes place n times per second, the current in the galvanometer due to this cause is —

$$\frac{nce}{P} \cdot \left(r_4 + \frac{r_1 r_2}{r_3 + r_1 + r_2} \right) \cdot \frac{r_1}{r_3 + r_1 + r_2};$$

therefore when the galvanometer deflection is zero—

$$\frac{e}{P} \cdot \frac{r_1}{r_3 + r_1 + r_g} = \frac{nce}{P} \left(r_4 + \frac{r_3 r_g}{r_3 + r_1 + r_g} \right) \cdot \frac{r_1}{r_3 + r_1 + r_g},$$

$$r_3 = ncr_1 \left(r_4 + \frac{r_3 r_g}{r_3 + r_1 + r_g} \right).$$

But the last fraction is negligible since r_3 is very small in comparison with r_1 , and therefore $nc = \frac{r_1}{r_1 r_4}$.

For a complete discussion when no restrictions are placed on the magnitudes of the resistances, the student is referred to "Absolute Measurements in Electricity and Magnetism," by A. Gray. The expression there obtained for nc is—

$$\frac{r \{ (r_1 + r_2 + r_b)(r_g + r_1 + r) - r_1^2 \}}{\{ r_1(r_3 + r_4 + r_b) + r_3 r_b \} \{ r_1(r_g + r_1 + r) + r_g r_1 \}},$$

which reduces to the above when r_1 and r_2 are very great in comparison with the other resistances.

Employing this method and using a spherical condenser, E. B. Rosa¹ found v to be 3.0004×10^{10} .

Sir J. J. Thomson and Mr. G. F. C. Searle² used a cylindrical condenser provided with guard rings of cylindrical form at the ends, which necessitated a slight modification of the bridge connections. The mean of their values for v is 2.9955×10^{10} .

The value of v has also been found by measuring a capacity in terms of an inductance and two resistances (see p. 326), and also in terms of a resistance and a time by means of the slow discharge of a condenser (see p. 312). Another interesting method is to determine the frequency of oscillatory discharge when a condenser discharges through a known resistance and inductance (see p. 338), the frequency being found by obtaining a photograph of the spark upon a revolving photographic plate. In this way Lodge and Glazebrook³ found $v = 3.009 \times 10^{10}$.

The later determinations give values differing very slightly from each other. There is little doubt that the value of $\frac{1}{\sqrt{k\mu}}$ is very nearly 3.00×10^{10} cms. per second, which is also the velocity of light in empty space.

Practical Units.—We have described in various places (see pp. 61 and 308) the manner in which the practical units are chosen in order that they may be of convenient sizes, while retaining simple relationships with the absolute electromagnetic units. Thus the ampere is

¹ E. B. Rosa, *Phil. Mag* (Ser 5), **28**, p. 315. 1889

² J. J. Thomson and G. F. C. Searle, *Phil Trans.*, **181**, p. 583. 1890.

³ O. J. Lodge and R. T. Glazebrook, *Cambr. Phil. Trans.*, **18**, p. 136. 1899.

one-tenth of the absolute C.G.S. electromagnetic unit of current, and the volt is 10^8 absolute unit of electromotive force. From these are derived the ohm, the joule and the watt, which are respectively 10^9 , 10^7 , and 10^7 times the corresponding absolute units. Similarly the farad is the capacity of a conductor which is raised in potential by one volt by a charge of one coulomb, and hence it is equal in value to $\frac{10^{-8}}{10} = 10^{-9}$ absolute units. This unit is still very large for practical purposes, so a millionth of it, called a micro-farad is usually employed; its value is therefore 10^{-15} absolute units. Again, the henry is the inductance of a circuit in which a rate of change of current of one ampere per second is accompanied by an electromotive force of 1 volt, and it is therefore 10^9 absolute units. Owing to its inconvenient size, the millihenry, or thousandth of a henry, is usually employed in practice. Its value is 10^6 absolute units.

The above electrical and magnetic units are collected into the following table --

Unit	Dimensions		Ratio of electromagnetic to electrostatic unit.	Practical unit	
	Electrostatic	Electromagnetic.		Name	Ratio of size to that of electromagnetic unit
Quantity	$M^{\frac{1}{2}}L^{-\frac{1}{2}}T^{-1}k^{\frac{1}{2}}$	$M^{\frac{1}{2}}L^{\frac{1}{2}}\mu^{-\frac{1}{2}}$	v	Coulomb	10^{-1}
Electromotive force	$M^{\frac{1}{2}}L^{\frac{1}{2}}T^{-1}k^{-\frac{1}{2}}$	$M^{\frac{1}{2}}L^{\frac{3}{2}}T^{-2}\mu^{\frac{1}{2}}$	v^{-1}	Volt	10^8
Electric intensity	$M^{\frac{1}{2}}L^{-\frac{1}{2}}T^{-1}k^{-\frac{1}{2}}$	$M^{\frac{1}{2}}L^{\frac{1}{2}}T^{-2}\mu^{\frac{1}{2}}$	v		
Electric displacement	$M^{\frac{1}{2}}L^{-\frac{1}{2}}T^{-1}k^{\frac{1}{2}}$	$M^{\frac{1}{2}}L^{-\frac{3}{2}}\mu^{-\frac{1}{2}}$	v^{-1}		
Electric current	$M^{\frac{1}{2}}L^{\frac{1}{2}}T^{-2}k^{\frac{1}{2}}$	$M^{\frac{1}{2}}L^{\frac{1}{2}}T^{-1}\mu^{-\frac{1}{2}}$	v	Ampere	10^{-1}
Electric resistance	$L^{-1}Tk^{-1}$	$L^2T^{-1}\mu$	v^{-2}	Ohm	10^9
Capacity	Lk	$L^{-1}T^2\mu^{-1}$	v^2	Farad	10^{-9}
Inductance	$L^{-1}T^2k^{-1}$	$L\mu$	v^{-2}	Henry	10^9
Magnetic field	$M^{\frac{1}{2}}L^{\frac{1}{2}}T^{-2}k^{\frac{1}{2}}$	$M^{\frac{1}{2}}L^{-\frac{1}{2}}T^{-1}\mu^{-\frac{1}{2}}$ *	v		
Magnetic induction	$M^{\frac{1}{2}}L^{-\frac{1}{2}}k^{-\frac{1}{2}}$	$M^{\frac{1}{2}}L^{-\frac{3}{2}}T^{-1}\mu^{\frac{1}{2}}$	v^{-1}		
Magnetic flux	$M^{\frac{1}{2}}L^{\frac{1}{2}}k^{-\frac{1}{2}}$	$M^{\frac{1}{2}}L^{\frac{3}{2}}T^{-1}\mu^{\frac{1}{2}}$ *	v^{-1}		
Magnetic moment	$M^{\frac{1}{2}}L^{\frac{3}{2}}k^{-\frac{1}{2}}$	$M^{\frac{1}{2}}L^{\frac{3}{2}}T^{-1}\mu^{\frac{1}{2}}$	v^{-1}		
Intensity of magnetisation	$M^{\frac{1}{2}}L^{-\frac{3}{2}}k^{-\frac{1}{2}}$	$M^{\frac{1}{2}}L^{-\frac{1}{2}}T^{-1}\mu^{\frac{1}{2}}$	v^{-1}		
Magnetic pole	$M^{\frac{1}{2}}L^{\frac{1}{2}}k^{-\frac{1}{2}}$	$M^{\frac{1}{2}}L^{\frac{3}{2}}T^{-1}\mu^{\frac{1}{2}}$	v^{-1}		
Energy	ML^2T^{-2}	ML^2T^{-2}		Joule	10^7
Rate of working	ML^2T^{-3}	ML^2T^{-3}		Watt	10^7

* The electromagnetic unit of magnetic field is called the Gauss, and that of magnetic flux, the Maxwell.

Determination of Practical Standards.—In order to be able to measure any quantity in terms of the above units, it is first necessary to obtain the value of some standard or standards. This has been undertaken by a number of experimenters, the quantities chosen being electric current, electrical resistance, and electromotive force. The first two must be determined independently in absolute measure, and the last can then be determined from them.

On constructing two coils of known dimensions and passing the current to be measured through them in series, an attraction or repulsion occurs between them, and if this be determined by attaching one of them to the arms of a balance, the value of the current in terms of the force may be calculated, when the relative position of the coils is known. This method was suggested by Lord Kelvin, and was employed by Lord Rayleigh and Mrs. Sidgwick, the current being at the same time passed through a silver voltameter, so that the electrochemical equivalent of silver in absolute measure is known. The value found was 0·0111795, and later determinations gave 0·011180. The International Congress of 1893 adopted as the absolute electromagnetic unit of current, that current which will deposit 0·011180 gramme of silver in one second, and this standard has since been legalised in this country. Although the latest determination gives 0·011183, the value for the legal standard is unchanged.

Several methods have been employed for determining the absolute standard of resistance, but they depend chiefly on a comparison between the electromotive force produced in a conductor rotating in a magnetic field, with the difference of potential between the ends of a conductor in which a current is flowing. As a result of many determinations, the International Congress of 1893 defined the ohm as the resistance to a steady current, of a column of mercury of uniform cross-section, having a length of 106·300 cms. and a mass of 14·4521 grammes, when its temperature is 0° C., and this was legalised in this country by an Order in Council dated August 23, 1894, and reaffirmed by an Order in Council dated January 10, 1910. The absolute unit of resistance is 10^{-9} of this. Previously to this the standard was that determined by a committee of the British Association in 1863, and known as the B.A. ohm, the value of which is 0·9866 of the international ohm at present used.

A specification adopted by the International Conference on Electrical Units and Standards, 1908, states that for purposes of electrical measurements, the tubes containing the mercury shall have a cross-section of one square millimetre, and shall be provided with spherical end pieces of 4 cms. diameter containing mercury, the outside edge of each tube being coincident with the inner surface of the spherical vessel. The leads are to be thin platinum wires fused into the glass spheres, the current leads being at an opposite end of a diameter to the entrance of the mercury column, and the potential leads midway between the entrance of the column and the current lead.

The resistance to be added to that of the column to allow for the effect of the end vessels is to be—

$$\frac{0.80}{1063\pi} \left(\frac{1}{r_1} + \frac{1}{r_2} \right) \text{ ohm,}$$

where r_1 and r_2 are the radii of the end sections of the bore of the tube.

Determination of the Ohm.—(i) *Rotating Coil.* The Committee of the British Association in 1863 adopted, for constructing a standard of resistance, the method of rotating a closed coil of wire about a vertical axis in the earth's magnetic field, the deflection of a magnetic needle being observed.

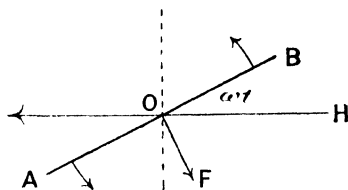

FIG. 353.

If AB in Fig. 353 be the plan of the circular coil when its plane makes angle ωt with the magnetic meridian, $\pi a^2 n H \sin \omega t$ is the magnetic flux passing through the coil, where a is its radius, n the

number of turns, H the horizontal component of the earth's magnetic field, and ω the angular velocity of rotation about the vertical axis O . The momentary electromotive force round the coil is—

$$-\pi a^2 n H \frac{d}{dt} (\sin \omega t) = -\pi a^2 n H \omega \cos \omega t,$$

and since this is an alternating electromotive force of maximum value, $-\pi a^2 n H \omega$, we know from p. 345 that the momentary current i is—

$$-\frac{\pi a^2 n H \omega}{\sqrt{l^2 \omega^2 + r^2}} \cos (\omega t - \theta),$$

since the current is angle θ in phase behind the electromotive force, where $\tan \theta = \frac{l\omega}{r}$, l being the inductance of the coil and r its resistance.

This current gives rise to a magnetic field OF whose value at the centre is $\frac{2\pi ni}{a}$ (p. 53). And the component of this at right angles to the meridian is therefore—

$$\begin{aligned} \frac{2\pi ni}{a} \cos \omega t &= -\frac{2\pi^2 a n^2 H \omega}{\sqrt{l^2 \omega^2 + r^2}} \cos (\omega t - \theta) \cos \omega t, \\ &= -\frac{2\pi^2 a n^2 H \omega}{\sqrt{l^2 \omega^2 + r^2}} (\cos^2 \omega t \cos \theta + \frac{1}{2} \sin 2\omega t \sin \theta). \end{aligned}$$

The mean value of $\cos^2 \omega t$ for a complete cycle we have seen (p. 348) to be $\frac{1}{2}$, and the mean value of $\sin 2\omega t$ is zero, therefore mean magnetic force at right angles to the meridian is—

$$-\frac{\pi^2 a n^2 H \omega}{\sqrt{l^2 \omega^2 + r^2}} \cos \theta.$$

In a similar manner we see that the instantaneous component of the field in the meridian is,

$$\begin{aligned} \frac{2\pi n i}{a} \sin \omega t &= -\frac{2\pi^2 a n^2 H \omega}{\sqrt{l^2 \omega^2 + r^2}} \cos(\omega t - \theta) \sin \omega t \\ &= -\frac{2\pi^2 a n^2 H \omega}{\sqrt{l^2 \omega^2 + r^2}} \left(\frac{1}{2} \sin 2\omega t \cos \theta + \sin^2 \omega t \sin \theta \right), \end{aligned}$$

the mean value of which is—

$$-\frac{\pi^2 a n^2 H \omega}{\sqrt{l^2 \omega^2 + r^2}} \sin \theta.$$

The resultant field in the meridian is therefore,

$$H - \frac{\pi^2 a n^2 H \omega}{\sqrt{l^2 \omega^2 + r^2}} \sin \theta,$$

and the suspended needle will then be in equilibrium when making an angle ϕ with the meridian such that—

$$\frac{\frac{\pi^2 a n^2 H \omega}{\sqrt{l^2 \omega^2 + r^2}} \cos \theta}{H - \frac{\pi^2 a n^2 H \omega}{\sqrt{l^2 \omega^2 + r^2}} \sin \theta} = \tan \phi.$$

Since H occurs in every term on the left-hand side of this equation it disappears, and we see that the equilibrium position of the needle is independent of its value;

$$\frac{\pi^2 a n^2 \omega \cos \theta}{\sqrt{l^2 \omega^2 + r^2} - \pi^2 a n^2 \omega \sin \theta} = \tan \phi;$$

$\tan \phi$ therefore depends upon the velocity of revolution ω . This must of course be so great that the separate impulses acting on the needle follow at intervals sufficiently small in comparison with the period of vibration of the needle for the deflection to be steady. If the inductance of the coil is small enough for the quantity $l\omega$ to be negligible in comparison with r , $\sin \theta = 0$ and $\cos \theta = 1$, and we then have—

$$r = \pi^2 a n^2 \omega \cot \phi.$$

The angular velocity ω having the dimensions of the inverse of a time, and a being a length, we see that r has the dimensions of a velocity, and its determination depends upon the accurate measurement of these two quantities, together with an angle ϕ .

It will be noticed that the effect of the torsion in the suspension fibre, and the influence of the magnetic field of the suspended needle in inducing current in the rotating coil, have been omitted. These must be measured and allowed for. Standard resistances constructed by comparison with the coil whose resistance was determined in absolute measure by this means were distributed by the British Association.

Lord Rayleigh,¹ in 1882, made a determination of the ohm by this method. The inductance of the coil was calculated from its dimensions and also determined by the method on p. 323. The velocity of rotation of the coil was determined by the stroboscopic method. He found that,

$$1 \text{ B.A. unit} = 0.98651 \text{ earth quadrant per second.}$$

A rotating coil method due to W. Weber,² in which the coil is turned through 180° in the earth's field, the current passing through a ballistic galvanometer and the throw being noted, has also been used by him and by G. Wiedemann,³ the latter of whom found the ohm to be the resistance of a column of mercury 106.162 cms. long, 1 sq. mm. in cross-section at 0° C . The method is similar in principle to that of the earth inductor described on p. 261.

Determination of the Ohm.—(ii) *Method of Lorenz.*⁴—The movement of a conductor in a magnetic field gives rise to an electromotive force which is equal to the rate at which magnetic flux is being cut by the conductor. If, then, a conducting disc of radius a be rotated with constant angular velocity, n times per second, when its plane is at right angles to a magnetic field of strength H , any radius of the disc cuts a flux $\pi a^2 H$ in each revolution, and therefore the electromotive force acting from the axis to the circumference is $\pi a^2 n H$. If the field is produced by a current i in a pair of circular coils co-axial with the disc (shown by a dotted circle in the diagram), $\pi a^2 H$ becomes mi , where m is the mutual inductance of the coils and the disc, and therefore, electromotive force is equal to nmi . This electromotive force is balanced against the difference of potential between the ends of a resistance r (Fig. 354) in series with the coils and through which the current i is flowing. When the galvanometer G is undisturbed—

$$ri = nmi,$$

or,

$$r = nm.$$

Lord Rayleigh and Mrs. Sidgwick⁵ carried out a measurement of

¹ Lord Rayleigh, *Phil. Trans.*, 173, p. 661. 1882.

² W. Weber, *Pogg. Ann.*, 82, p. 337. 1851.

³ G. Wiedemann, *Abhandl. Berlin Akad. d. Wiss.*, 1884.

⁴ L. Lorenz, *Pogg. Ann.*, 149, p. 251. 1873.

⁵ Lord Rayleigh and Mrs. Sidgwick, *Phil. Trans.*, 174, p. 295. 1883.

the ohm by this method in 1883, but instead of employing a calibrated tube of mercury for the resistance r , they used three wire resistances, a , b , and c (Fig. 355), of which a is the smallest and carries most of the current i , while c is large compared with b . The fall of potential over b is balanced against the electromotive force in the rotating disc. If then i be the total current in the fixed coils (Fig. 354), that in b and c is $\frac{ai}{a+b+c}$, and the difference of potential between the ends of b is $\frac{abi}{a+b+c}$. The resistance a consisted of two unit coils in parallel, b was a platinum-silver $\frac{1}{10}$ unit, and c was, in three series of experiments, 10, 16 and 20 respectively. The value of b in terms of the absolute

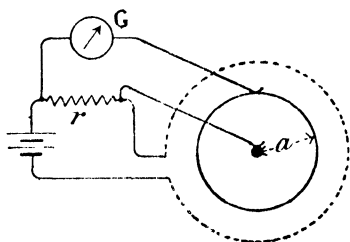

FIG. 354.

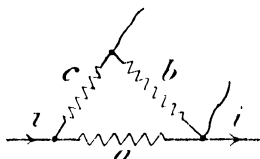

FIG. 355.

unit is then given by the experiment, and the mercury column that has the unit resistance can therefore be found if the specific resistance of mercury in terms of the B.A. unit, in which b is known can be found. This forms the subject of another paper by Lord Rayleigh and Mrs. Sidgwick.¹

To return to the Lorenz method, the rotating disc is of brass, and has a diameter of 31.072 cms. ; and contact was made with its edge by a copper brush well amalgamated, the contact at the shaft being of a similar kind and touching it on a circle whose diameter is 2.096 cms. The mean distance apart of the mean planes of the two coils is 3.275 cms. for two series of experiments, and 30.6944 cms. for a third. From careful measurements of the coils, the value of m for the first two series of experiments is found to be 214.569, and for the third 110.392. In the first series of experiments the speed of the disc was about 12.8 revolutions per second, in the second 8, and in the third 12.8, and was determined by the stroboscopic method, the standard being a calibrated tuning-fork.

The general scheme of connections is shown in Fig. 356. In order to eliminate the electromotive forces in the galvanometer circuit due to thermo-electric effects at the sliding contacts, and the cutting of the

¹ Lord Rayleigh and Mrs. Sidgwick, *Phil. Trans.*, 174, p. 173. 1883.

earth's vertical magnetic field by the disc as it rotates, a small difference of potential is maintained between the points A and B, connected by a low resistance which is adjusted until the galvanometer

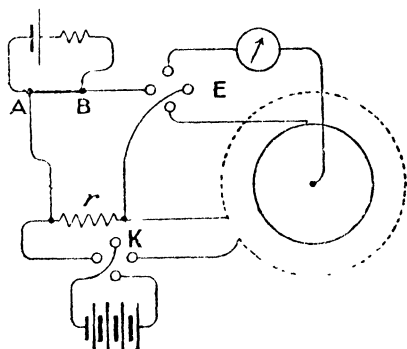

FIG. 356.

reading remains constant with the disc running, but without the main current, whether the galvanometer circuit is broken or closed. In the actual experiment r is not adjusted to give an exact balance, but some value such as r_1 is employed, and the difference of the galvanometer readings when the main current is reversed by means of the key K is observed. r_1 is then changed to the value r_2 , such that the galvanometer deflection for either position of K is the

reverse to that in the previous case, and the difference in deflection for a reversal again noted. By interpolation the value of r for an exact balance is calculated.

The mean of the results gave the value of the B.A. unit to be 0.98677×10^9 C.G.S. units.

Determination of the Ohm.—(iii) *Mutual Inductance of Two Coils.*—Kirchhoff¹ suggested a method, the principle of which has been given on p. 322. Using a galvanometer of the suspended magnet type, the throw when current i is started in the primary coil is given by—

$$\frac{mi}{r_1} = \frac{HT}{\pi G} \sin \frac{1}{2}\theta,$$

and when a steady current is maintained in the secondary by the fall of potential across a small resistance r , in the primary—

$$\frac{irG}{r_1 H} = \tan \theta_1$$

$$\therefore m = \frac{rT}{\pi} \cdot \frac{\sin \frac{1}{2}\theta}{\tan \theta_1},$$

$$\text{or,} \quad r = m \frac{\pi}{T} \frac{\tan \theta_1}{\sin \frac{1}{2}\theta}.$$

If then m is determined by calculation, in absolute measure, and T , θ and θ_1 observed, r is known.

¹ G. Kirchhoff, *Pogg. Ann.*, 76, p. 412. 1849.

This method has been used by Rowland, Glazebrook, and others. As a mean of his results, Glazebrook¹ has given that—

$$1 \text{ B.A. unit} = 0.98665 \times 10^9 \text{ C.G.S. units.}$$

The method of finding the heat produced in a wire by means of the calorimeter was employed by Joule; and also the method of damping (see p. 258) due to W. Weber has been employed for determining the magnitude of the ohm in terms of the resistance of a mercury column, but the results are not so consistent, nor are the methods capable of such accuracy as the above.

Determination of the Electro-chemical Equivalent of Silver.—

With the object of defining the C.G.S. unit of current in terms of some quantity that may be conveniently reproduced, Lord Rayleigh and Mrs. Sidgwick² made a determination of the electro-chemical equivalent of silver. The form of voltameter employed has already been described (p. 69). The current is passed for a measured time, about three quarters of an hour, through two or three such voltameters in series, and through a system of coaxial coils shown in Fig. 357. The smaller coil is suspended

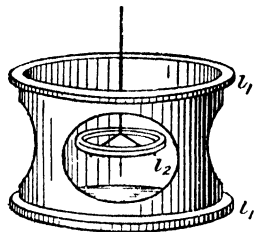

FIG. 357.

from the beam of a balance, and the force upon it due to the currents is found by taking the difference in the weighings when the current in the larger coils, which are fixed, is reversed. We know that the potential of a coil carrying current i_2 due to another carrying current i_1 is mi_1i_2 , where m is the mutual inductance of the coils (p. 314). Hence

the force on the small coil in the direction of the axis is $i_1i_2 \frac{dm}{dx}$, where x is in the direction of the axis. The actual calculation of the force between the coils is beyond the scope of this book, and the student who wishes for more information is advised to consult the original paper. It may be noted that the small coil is placed in such a position that the force on it is a maximum, and hence does not vary appreciably for a small change in its position, thus obviating the necessity of determining the relative positions of the coils with any high degree of accuracy.

The best results are obtained when a solution of pure silver nitrate in water is used in the voltameter, and with a 3-inch platinum bowl and a solution of strength 15 to 30 per cent., a current of 1 ampere may be passed for an hour.

As a mean result it was found that the C.G.S. unit of current deposits 0.0111794 gramme of silver per second.

¹ Glazebrook, *B. A. Report*, p. 97. 1890.

² Lord Rayleigh and Mrs. Sidgwick, *Phil. Trans.*, 175, p. 411. 1884.

Mr. F. E. Smith and Prof. T. Mather¹ found, in 1908, that the ampere deposits 0.00111827 gramme of silver per second.

Standards of Electromotive Force.—In performing the above-mentioned work on the electro-chemical equivalent of silver, Lord Rayleigh and Mrs. Sidgwick at the same time found the electromotive force of the Clark cell (p. 190).

The method is essentially that of the potentiometer. A battery of two Leclanché cells, B (Fig. 358), maintains steady current in the two resistance boxes C and D, and the electromotive force of the Clark

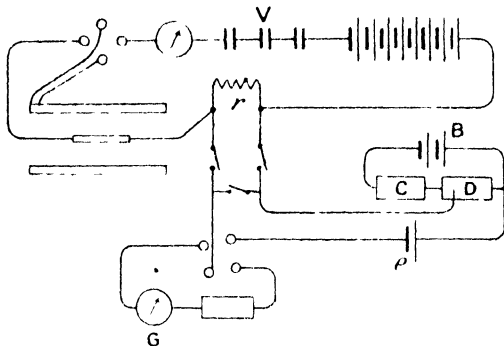

FIG. 358.

cell e is balanced against the fall of potential over the box D. The total resistance of the two boxes C and D is maintained constant so that the current i in them is constant. Then $e = r_1 i$, where r_1 is the resistance in D when the galvanometer G indicates zero current. The potential difference between the ends of the resistance r which carries the current of the electrolysis experiment (p. 403), and passes through the voltmeter V, is now included in the circuit of e , and if P is this potential difference, the resistance r_2 of D which is now required to balance the electromotive force $e - P$, is $r_2 i$.

$$\therefore \frac{e - P}{e} = \frac{r_2}{r_1},$$

and,

$$P = e \left(1 - \frac{r_2}{r_1} \right),$$

or if the current i in r be known from the weighing experiment—

$$ri = e \left(1 - \frac{r_2}{r_1} \right).$$

¹ F. E. Smith and T. Mather, *Phil. Trans.*, Ser. A, 207, p. 546. 1908.

The mean result indicated that the electromotive force of the Clark cell at 15° C. is 1·435 volt.

By the Order in Council dated August 24, 1894, the volt was defined as 0·6974, that is $\frac{1}{1·434}$ of the difference of potential between the terminals of a Clark cell at 15° C., which was thus legalised. A specification attached, defined the manner in which the cell was to be constructed.

The Weston or cadmium cell has since been substituted for the Clark cell as an international standard of electromotive force, and the value adopted by the International Conference on Electrical Units and Standards of 1908 is 1·0184 volts at 20° C. More recent measurements have shown that the value 1·0183 is more correct, and this has been adopted in place of the above.

CHAPTER XIV

ELECTROMAGNETIC RADIATION

Fundamental Equations.—The state of a field of electric and magnetic force at any point, may be represented by means of three fundamental relations, already dealt with in their general forms, which it is now our purpose to express in reference to rectangular co-ordinates.

(i) *Gauss's Law.*—The total normal electrical induction over a closed surface is equal to 4π times the total charge within it (p. 125). A similar relation holds in the magnetic case (p. 233). Let us consider the electric intensity E at a point A (Fig. 359) to be resolved into components parallel to the three axes of co-ordinates, the components being P parallel to OX , Q and R parallel to OY and OZ respectively. Then if P varies from point to point as we move

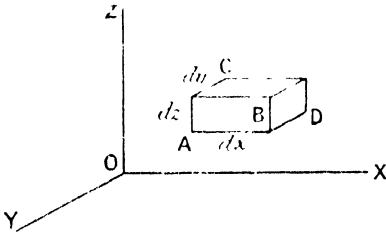

FIG. 359.

from A in a direction parallel to OX , at the rate $\frac{dP}{dx}$, its value at the

face BD of the very small rectangular solid $ABCD$ will be $P + \frac{dP}{dx} dx$.

The normal induction over the face AC is $kP \cdot dy \, dz$, where k is the dielectric constant and $dy \cdot dz$ the area of the face AC . The normal induction over BD is $k \left(P + \frac{dP}{dx} dx \right) dy \, dz$, and the difference between these two is the contribution of the two faces AC and BD to the total normal induction over the whole surface. That is—

$$k \left(P + \frac{dP}{dx} dx \right) dy \, dz - kP dy \, dz = k \frac{dP}{dx} dx \, dy \, dz.$$

Treating the faces AB and CD in the same way, we get $k \frac{dQ}{dy} dx \, dy \, dz$ as the contribution to the normal induction for these faces, and similarly $k \frac{dR}{dz} dx \, dy \, dz$ that for the faces AD and BC .

If now there is a volume density of electric charge ρ , the amount of charge within the surface ABCD is $\rho dx dy dz$, and thus from Gauss's law we have—

$$k \left(\frac{dP}{dx} + \frac{dQ}{dy} + \frac{dR}{dz} \right) dx dy dz = 4\pi\rho dx dy dz,$$

or,
$$\frac{dP}{dx} + \frac{dQ}{dy} + \frac{dR}{dz} = \frac{4\pi\rho}{k}.$$

For the magnetic field, if α , β , and γ are the components of \mathbf{H} , the equation is—

$$\frac{d\alpha}{dx} + \frac{d\beta}{dy} + \frac{d\gamma}{dz} = \frac{4\pi\rho}{\mu}$$

where ρ is the volume density of magnetic pole, and μ the magnetic permeability of the medium. This is Poisson's equation.

If $\rho = 0$, we have for the electric field—

$$\left. \begin{aligned} \frac{dP}{dx} + \frac{dQ}{dy} + \frac{dR}{dz} &= 0 \\ \frac{d\alpha}{dx} + \frac{d\beta}{dy} + \frac{d\gamma}{dz} &= 0 \end{aligned} \right\} \dots \dots \dots (i)$$

The quantity $\frac{dP}{dx} + \frac{dQ}{dy} + \frac{dR}{dz}$ is frequently called the *divergence* of the vector quantity \mathbf{E} , and is written $\text{div. } \mathbf{E}$, since it represents the rate at which \mathbf{E} increases or diminishes as we pass outwards from the point; then—

$$\text{div. } \mathbf{E} = \frac{4\pi\rho}{k}.$$

(ii) *Line Integral of Magnetic Field round a Current.*—On p. 230 we saw that the work done in carrying a unit pole round a closed path through which a current is flowing, is equal to 4π times the current; in other words, the line integral of the magnetic field round the closed path is 4π times the current.

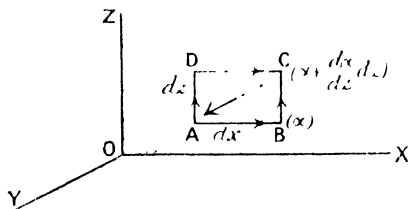

FIG. 360.

If u , v , and w be the components of the current density, or current per unit area, the current flowing through the small rectangle ABCD (Fig. 360) whose plane is perpendicular to OY is $v dx dz$, the area being $dx dz$. If the value of the magnetic field along AB be a and along

DC be $\alpha + \frac{d\alpha}{dz}dz$, the work done on the pole as it moves along AB is αdx , and along CD is $-\left(\alpha + \frac{d\alpha}{dz}dz\right)dx$. Similarly, for DA it is $-\gamma dz$, and for BC $+\left(\gamma + \frac{d\gamma}{dx}dx\right)dz$.

Therefore for the whole circuital path ABCD—

$$\begin{aligned} \text{Work done} &= \alpha dx - \left(\alpha + \frac{d\alpha}{dz}dz\right)dx - \gamma dz + \left(\gamma + \frac{d\gamma}{dx}dx\right)dz \\ &= \left(\frac{d\gamma}{dx} - \frac{d\alpha}{dz}\right)dx dz; \end{aligned}$$

and the above law therefore gives us—

$$4\pi v \, dx \, dz = \left(\frac{d\gamma}{dx} - \frac{d\alpha}{dz}\right)dx \, dz,$$

or,

$$-4\pi v = \frac{d\alpha}{dz} - \frac{d\gamma}{dx}.$$

Treating the other components of the current u and w in a similar manner, we get two other similar equations. The law may then be expressed by the three equations—

$$\left. \begin{aligned} -4\pi u &= \frac{d\gamma}{dy} - \frac{d\beta}{dz} \\ -4\pi v &= \frac{d\alpha}{dz} - \frac{d\gamma}{dx} \\ -4\pi w &= \frac{d\beta}{dx} - \frac{d\alpha}{dy} \end{aligned} \right\} \dots \dots \dots \text{(ii)}$$

(iii) *Electromotive Force round Circuit through which the Magnetic Flux is varying.*—The law $e = -\frac{dN}{dt}$ (p. 249) may be expressed by means of its components in an exactly similar manner. Referring to Fig. 360, if μ is the magnetic permeability of the medium, the flux N through the rectangle ABCD is $\mu\beta dx \cdot dz$, and $dx \cdot dz \frac{d}{dt}(\mu\beta)$ is the rate of change of flux. If the component of E along AB is P , and along DC $\left(P + \frac{dP}{dz}\right)dz$, and the components along AD and BC respectively R and $\left(R + \frac{dR}{dx}dx\right)$, the whole electromotive force e round the rectangle is—

$$Pdx - \left(P + \frac{dP}{dz}dz\right)dx - Rdz + \left(R + \frac{dR}{dx}dx\right)dz = \left(\frac{dR}{dx} - \frac{dP}{dz}\right)dx dz;$$

and since $e = -\frac{dN}{dt}$, we have, remembering Rule II, p. 249—

$$\mu \frac{d\beta}{dt} = \frac{dP}{dz} - \frac{dR}{dx}.$$

With the two corresponding equations for the components α and γ , we have altogether—

$$\left. \begin{aligned} \mu \frac{d\alpha}{dt} &= \frac{dR}{dy} - \frac{dQ}{dz} \\ \mu \frac{d\beta}{dt} &= \frac{dP}{dz} - \frac{dR}{dx} \\ \mu \frac{d\gamma}{dt} &= \frac{dQ}{dx} - \frac{dP}{dy} \end{aligned} \right\} \dots \dots \dots \text{(iii)}$$

Maxwell's Displacement Current.—The above sets of equations are the expression of certain experimentally established laws, and do not depend upon any assumption as to the nature of the mode of action occurring in the dielectric. In equations (ii) the current u, v, w , means that an electric charge is moving in a certain direction, and we know that this motion cannot be continuous unless the medium is an electrical conductor. The possibility of a current in a dielectric was pointed out by Maxwell, who, following Faraday, was bent upon explaining electromagnetic phenomena in terms of actions occurring in the dielectric. According to Maxwell, any change in the electrical induction in a medium is an electric current. Thus, when a current flows into a condenser (Fig. 361) by means of conducting leads AB and CD, the current in these leads is the rate at which charge passes on to the plates of the condenser. If, for simplicity, we assume the plates of the condenser each to have unit area, the charge on each plate is the surface density σ , and therefore the current i in the leads is given by—

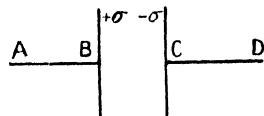

FIG. 361.

$$i = \frac{d\sigma}{dt}.$$

But the electric displacement D in the medium between the plates, we saw on p. 130 to be equal to σ ;

$$\therefore i = \frac{dD}{dt}.$$

Hence we may consider the current to be continuous through the condenser, its value in the dielectric itself being the rate of change of the electrical displacement; the essential difference between the

dielectric and a conductor being that D cannot exceed a certain amount for each value of the electric intensity, so that after the current has flowed for a short time, D becomes constant and the current ceases.

The question may be better understood by considering an analogy. Let the condenser be replaced by a vessel having an indiarubber membrane stretched across it so as to obstruct the flow of water brought in by the pipe AB (Fig. 361) and emerging by the pipe CD . For a given difference of hydrostatic pressure between B and C , the flow continues until the displacement of the membrane reaches a certain amount, determined by its elasticity, and then ceases; but while the displacement is increasing there is an actual current of water, in through AB and out through CD .

According to Maxwell, the magnetic effect of a displacement current is similar to that of a conduction current, the distinction between the two being quite artificial. Equations (ii) therefore apply to the displacement current, which is the only current, in a dielectric.

Rowland¹ has proved that a moving "statical" charge produces magnetic effects similar to those of a conduction current, by rotating an ebonite disc having alternate sectors which were gilt and charged, and observing the deflection of a magnet, placed under and near to the disc. The direction of the deflection of the magnet was that which would be produced by an electric current corresponding to the moving charge, and was reversed on reversal of the sign of the charge, or the direction of rotation.

We may now, by means of the relation on p. 130, write the components u , v , and w , of the displacement current in terms of those of electric intensity, P , Q and R , and the dielectric constant of the medium.

The general equation $D = \frac{kE}{4\pi}$, by differentiation with respect to t gives—

$$\dot{D} = \frac{dD}{dt} = \frac{k}{4\pi} \cdot \frac{dE}{dt}$$

which, written in terms of its components, becomes—

$$u = \frac{k}{4\pi} \cdot \frac{dP}{dt}, \quad v = \frac{k}{4\pi} \cdot \frac{dQ}{dt}, \quad \text{and,} \quad w = \frac{k}{4\pi} \cdot \frac{dR}{dt},$$

and substituting these values for u , v , and w in equations (ii), we have—

$$\left. \begin{aligned} -k \frac{dP}{dt} &= \frac{d\gamma}{dy} - \frac{d\beta}{dz} \\ -k \frac{dQ}{dt} &= \frac{d\alpha}{dz} - \frac{d\gamma}{dx} \\ -k \frac{dR}{dt} &= \frac{d\beta}{dx} - \frac{d\alpha}{dy} \end{aligned} \right\} \dots \dots \dots \text{(iv)}$$

¹ H. A. Rowland and C. T. Hutchinson, *Phil. Mag.* (Ser. 5), **27**, p. 445. 1889.

Equations (iii) and (iv) contain the six variable quantities α , β , γ and P , Q , R , and by eliminating five of these we can obtain an equation involving one only. Before dealing with this general equation we will treat one or two simpler cases.

Propagation of Plane Wave.—The simplest case of wave motion to consider is that of a plane wave, that is, a wave in which the electric intensity is at any instant the same over the whole plane. Let us take the plane YOZ (Fig. 362) as the plane of the wave, by which we mean that all over this plane the electric and the magnetic intensities are of constant value at any given moment. It follows that these quantities have each the same value for all values of y and z , and their variations in the Y and Z directions are zero; hence their differential coefficients with respect to y and z are likewise zero.

Equations (iii) then reduce to—

$$\mu \frac{d\alpha}{dt} = 0, \quad \mu \frac{d\beta}{dt} = -\frac{dR}{dx}, \quad \text{and,} \quad \mu \frac{d\gamma}{dt} = \frac{dQ}{dx},$$

and consequently α is zero or a constant. But constant values do not enter into the wave propagation, so that for our purposes we may put $\alpha = 0$.

Similarly equations (iv) reduce to—

$$k \frac{dP}{dt} = 0, \quad k \frac{dQ}{dt} = \frac{d\gamma}{dx}, \quad \text{and,} \quad k \frac{dR}{dt} = -\frac{d\beta}{dx}.$$

Therefore $P = 0$, and since we have seen that $\alpha = 0$, it follows that the directions of the electric and magnetic intensities are entirely in the plane of the wave.

We may choose any direction in the plane YOZ that we please for that of the electric intensity, and we will therefore take it parallel to OZ .

Then $Q = 0$, and we see from either of the relations

$$\mu \frac{d\gamma}{dt} = \frac{dQ}{dx}, \quad \text{or,} \quad k \frac{dQ}{dt} = \frac{d\gamma}{dx}$$

that in this case $\gamma = 0$.

Hence the electric and magnetic intensities are at right angles to each other; if R is the only component of the electric intensity, β is the only component of the magnetic field.

The equations now reduce to

$$\mu \frac{d\beta}{dt} = -\frac{dR}{dx}, \quad \text{and,} \quad k \frac{dR}{dt} = -\frac{d\beta}{dx}.$$

Differentiating the first with respect to t and the second with respect to x ,

$$\begin{aligned} \mu \frac{d^2\beta}{dt^2} &= -\frac{d^2R}{dxdt}, \text{ and, } k \frac{d^2R}{dxdt} = -\frac{d^2\beta}{dx^2}, \\ \therefore \frac{d^2\beta}{dt^2} &= \frac{1}{k\mu} \frac{d^2\beta}{dx^2}. \end{aligned}$$

Or, differentiating the first with respect to x and the second with respect to t ,

$$\begin{aligned} \mu \frac{d^3\beta}{dxdt} &= -\frac{d^3R}{dx^2}, \text{ and, } k \frac{d^3R}{dt^2} = -\frac{d^3\beta}{dxdt}, \\ \therefore \frac{d^3R}{dt^2} &= \frac{1}{k\mu} \frac{d^3R}{dx^2}. \end{aligned}$$

This is the form of the general equation to the motion of a plane wave, the direction of propagation being parallel to the axis OX, and its general solution is $R = f_1(x - vt) + f_2(x + vt)$, where $v^2 = \frac{1}{k\mu}$ and f and f_2 are any functions. The truth of this may be established by differentiating this value of R twice with respect to t and twice with respect to x , and substituting the values in the differential equation. $f_1(x - vt)$ and $f_2(x + vt)$ are general expressions for wave motion along the axis of x , the former in the direction OX and the latter in the reverse direction XO. For, after a given interval of time t_1 the expression $f_1(x - vt)$ becomes $f_1(x - vt - vt_1)$, and if the origin be moved forward along OX by the distance vt_1 , the abscissæ referred to the new origin being x_1 , then $x = x_1 + vt_1$. The expression for the disturbance is then $f_1(x_1 + vt_1 - vt - vt_1) = f_1(x_1 - vt)$; that is, referred to the new origin it has the same form as it had when referred to the old origin at a time t_1 earlier. Its form is therefore unchanged, but it has moved forward with velocity v .

In a similar manner the wave $f_2(x + vt)$ may be shown to travel unchanged in form and with velocity v in the opposite direction to the wave $f_1(x - vt)$.

We shall only consider the wave which travels forward, and only the most important case of such a wave, namely that in which R and β vary harmonically.

Let $R = R_0 \sin \frac{2\pi}{\lambda}(x - vt)$; then at the instant from which time is reckoned, $t = 0$, and

$$R = R_0 \sin \frac{2\pi}{\lambda} x.$$

This equation gives the value of R at all points in space at this instant, and the ordinates of the curve R (Fig. 362) represent the distribution of the electric intensity. Although the curve is drawn with the axis OX as axis of reference, it must be understood that the

value of R at all points in any plane parallel to YOZ is the same at each instant, and is represented by the ordinate of the curve. If x be increased by the length λ ,

$$R = R_0 \sin \frac{2\pi}{\lambda}(x + \lambda) = R_0 \sin \left(\frac{2\pi}{\lambda}x + 2\pi \right)$$

and the curve begins to repeat itself. λ is called the wave-length,

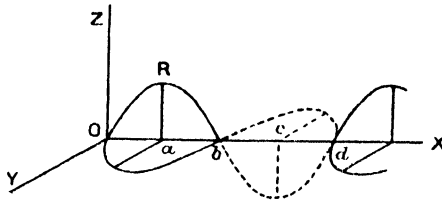

FIG. 362.

which in the diagram is the length Od . At the point b , $x = \frac{\lambda}{2}$ and $R = 0$; while at a and c , x is respectively $\frac{\lambda}{4}$ and $\frac{3\lambda}{4}$, and $R = R_0$ and $-R_0$ respectively.

Again, if the wave travels distance λ in time T , $\frac{\lambda}{T}$ is the velocity v , and substituting this value for v in the equation for R , we have —

$$R = R_0 \sin 2\pi \left(\frac{x}{\lambda} - \frac{t}{T} \right).$$

In order to find the expression for β , we make use of the equation

$$\begin{aligned} \frac{d\beta}{\mu dt} &= - \frac{dR}{dx} \\ \frac{dR}{dx} &= + \frac{2\pi}{\lambda} R_0 \cos 2\pi \left(\frac{x}{\lambda} - \frac{t}{T} \right), \\ \therefore \frac{d\beta}{dt} &= - \frac{2\pi}{\mu\lambda} R_0 \cos 2\pi \left(\frac{x}{\lambda} - \frac{t}{T} \right). \end{aligned}$$

Integrating which, we get,

$$\beta = \frac{T}{\mu\lambda} R_0 \sin 2\pi \left(\frac{x}{\lambda} - \frac{t}{T} \right).$$

But,

$$\frac{T}{\lambda} = \frac{1}{v} = \sqrt{k\mu},$$

$$\therefore \beta = \sqrt{\frac{k}{\mu}} R_0 \sin 2\pi \left(\frac{x}{\lambda} - \frac{t}{T} \right).$$

The maximum value of β is therefore $\sqrt{\frac{k}{\mu}} R_0$, and calling this β_0 , we have—

$$\beta = \beta_0 \sin 2\pi \left(\frac{x}{\lambda} - \frac{t}{T} \right).$$

This curve also is plotted in Fig. 362.

Magnetic Field and Motion of Faraday Tubes.—The followers of Faraday and Maxwell have insisted upon the possibility of explaining electrical phenomena in terms of processes occurring in the dielectric, and in particular Sir J. J. Thomson has shown that while on the one hand electrostatic phenomena may be described in terms of tubes of induction and the stresses occurring in them, on the other hand a magnetic field is simply an attribute of the Faraday tubes in motion. In his work on “Recent Researches in Electricity and Magnetism” he has shown that the ordinary electromagnetic laws are consistent with the assumption that the motion of the ends of the Faraday tubes constitute the electric current in the conductor along which they are moving, while in the dielectric the magnetic field is a vector quantity drawn at right angles to the tubes and to their direction of motion, whose magnitude is $4\pi DV \sin \theta$, where θ is the angle between the tube and its direction of motion, and D is the number of unit tubes per unit area at right angles to their direction, or as we saw on p. 130, the electric displacement,¹ and V is the velocity of the tubes. When the motion of the tubes is at right angles to their direction, $\sin \theta = 1$, and

$$H = 4\pi DV, \text{ or } H = kEV,$$

since,

$$E = \frac{4\pi D}{k}$$

If AC and BD (Fig. 363) are the two plates of a condenser of

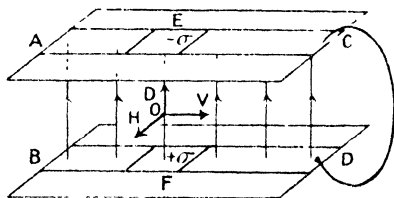

FIG. 363.

which AC is negatively charged and BD positively, then on connecting them by the wire CD, the Faraday tubes whose ends are near C and D approach each other along the conducting path now provided, and leave a space into which the neighbouring ones are pushed by their lateral pressures (p. 135). These in their turn collapse along CD,

so that there is a general movement of the tubes, a few of which are indicated in the diagram, in the direction OV. This means a conduc-

¹ Sir J. J. Thomson uses the letter N to represent this quantity, but we have used D in order to emphasise the identity with Maxwell's electric displacement and to avoid confusion with N , the magnetic flux.

tion current along BD where the positive ends of the tubes are travelling, and in AC a positive current from C to A in the opposite direction to the travel of the negative ends of the tubes. The displacement current in the dielectric is from the upper plate to the lower, since D is diminishing.

When the plates are so large that the electric field between them may be considered to be uniform, consider two strips of unit width in the direction of the currents in AC and BD. The charges upon unit areas F and E of these strips are $+\sigma$ and $-\sigma$ respectively, and these are equal to D, the electric displacement at the point O between them. If at any instant, these charges are moving with velocity V, the current i in each strip is $\sigma V = DV$. But if width of plate is b , the total current in either is ib , and the line integral of the magnetic field linked with the current is $4\pi ib$ (p. 230), and $Hb = 4\pi ib$, and therefore the magnetic field H at the point O between the plates at the given instant is $4\pi i$ —

$$\therefore H = 4\pi DV.$$

It should be noticed that the direction of the displacement current is in the line of D, that is at right angles to the motion of the tubes.

Plane Wave considered as Motion of Faraday Tubes. — Returning to the case of the plane wave, we may, in order to get a vivid picture of

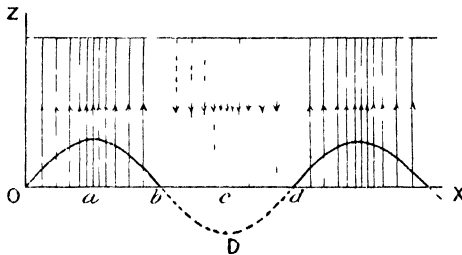

FIG. 364.

the processes occurring, replace the electrical intensity R by the displacement $\frac{kR}{4\pi} = D$, which represents the number of Faraday tubes per unit area, and our equation for the wave becomes—

$$D = D_0 \sin 2\pi \left(\frac{x}{\lambda} - \frac{t}{T} \right)$$

where,

$$D_0 = \frac{kR_0}{4\pi}.$$

The distribution of Faraday tubes at the time $t = 0$ will therefore be somewhat as shown in Fig. 364, in which the vertical lines represent

the tubes, their number per unit area being D , the electrical displacement. The full lines represent positive values of D and the dotted lines negative values, and they are drawn so that the closeness with which they are packed, or their number per unit length measured along OX , is proportional to the ordinate of the curve,

$$D = D_0 \sin 2\pi \left(\frac{x}{\lambda} - \frac{t}{T} \right)$$

remembering that the diagram is a section of the whole field, the direction of the axis OY being at right angles to the plane of the diagram. Every section of the field parallel to the plane ZOX would be similar to the diagram at the given instant, since the value of D over any plane parallel to YOZ is constant.

If now the whole system of tubes is imagined to be moving in the direction OX with velocity v , we shall have a representation of the harmonic plane wave travelling forwards, in accordance with Maxwell's equations.

The magnetic intensity β is everywhere at right angles to D and to v , and is therefore perpendicular to the plane of the diagram, its magnitude being given by $\beta = 4\pi Dv$ (p. 414). Since v is constant, β is at each point proportional to D , and is therefore a maximum at points a and c and zero at the points b and d . In fact, its value is given by the curve β in Fig. 362, which fact is consistent with the result obtained on p. 411, directly from the equations of the field.

A similar diagram for the magnetic intensity might be drawn, the plane YOX being taken instead of ZOX .

The wave that we are considering is polarised, in the optical sense, the electrical displacement being everywhere parallel to OZ , and the magnetic intensity parallel to OY . Considerations of the problem of reflection have shown that the magnetic intensity takes place in what in optics is called the plane of polarisation, the electric intensity being at right angles to it. YOX is therefore the plane of polarisation. It is not easy to see how the condition indicated in Figs. 362 and 364 can be brought about at a given place in the dielectric, but if an electric oscillation in a given direction occur at a point at a very great distance, the waves, of whatever form they may be near the point, are practically plane at great distances from it, and although the problem of the origin of the waves may present many difficulties, these are very much reduced when the waves have spread out far enough to become plane.

Energy of Wave.—The energy associated with the electric displacement D in the dielectric we have seen to be $\frac{2\pi D^2}{k}$ per unit volume (p. 132), or $\frac{kR^2}{8\pi}$, where R is the electric intensity. In the case of a plane wave, R varies harmonically at every given point of the

medium, and therefore the mean value of R^2 for a cycle of change is $\frac{1}{2}R_0^2$ (p. 348), where R_0 is the maximum value of R . Hence the mean value of the energy per unit volume of the dielectric, as the wave passes through it, is $\frac{kR_0^2}{16\pi}$. Similarly, on account of the magnetic field

β , the mean energy per unit volume of the medium is $\frac{\mu\beta_0^2}{16\pi}$, and the mean energy per unit volume due to both these effects is $\frac{kR_0^2 + \mu\beta_0^2}{16\pi}$, and is the proper measure of the intensity of the radiation at any point.

We have seen above, that $\beta_0 = \sqrt{\frac{k}{\mu}} R_0$ (p. 414), and therefore $\mu\beta_0^2 = kR_0^2$. Consequently—

$$\text{energy per unit volume} = \frac{kR_0^2}{8\pi} = \frac{\mu\beta_0^2}{8\pi} = \frac{R_0\beta_0}{8\pi v}$$

The energy of the wave is therefore half of it associated with the electrical intensity or displacement, the other half being associated with the accompanying magnetic field.

Poynting's Theorem.—An extremely important theorem on the transfer of energy, due to Prof. Poynting,¹ throws a great deal of light upon the propagation of electromagnetic waves, and also upon the flow of energy when a current is passing in a conductor. On p. 414 we saw that in a plane wave, the magnetic intensity β is related to the electric displacement D , by the equation $\beta = 4\pi Dv$, or since $D = \frac{kR}{4\pi}$, $\beta = kRv$, where β and R are at right angles to each other and to the direction of propagation, v being the velocity whose value is $\frac{1}{\sqrt{k\mu}}$. From Fig. 363 on p. 414 it will be seen that directions of β , R , and v are related in the manner given by the left-hand law on p. 239. Now, the energy per unit volume is $\frac{\mu\beta^2}{8\pi}$, due to the magnetic field, and $\frac{kR^2}{8\pi}$ due to the electrical field, and the sum of these two is—

$$\frac{\mu\beta^2 + kR^2}{8\pi} = \frac{\mu\beta kRv + kR \cdot \frac{\beta}{kv}}{8\pi} = \frac{\beta R}{4\pi v}$$

from above.

Since the condition is travelling forwards with velocity v , energy is streaming past the point considered at the rate $\frac{\beta R}{4\pi v} \cdot v = \frac{\beta R}{4\pi}$ units

¹ J. H. Poynting, *Phil. Trans. Roy. Soc.*, 175, p. 343. 1884.

per second through each unit of area of cross-section of the wave at any instant. In all other cases of the transference of energy, as, for example, the flow of heat, the energy entering a given space may be measured by the amount passing through the boundary of the space. Prof. Poynting suggested that the above may be the expression of a very general law, the direction of the flow of energy being determined by the directions of the electrical and magnetic intensities, its value being proportional to their product. If the direction of one of the quantities β or R be reversed, the direction of the flow of energy, that is, of the wave propagation, is reversed; a conclusion which we shall arrive at independently on p. 432.

The theorem may be applied to several important cases:—

(i) The steady current i in a wire is accompanied by a dissipation of energy at the rate ie units per unit length of wire, where e is the fall of potential per unit length of the wire. In the air immediately surrounding the wire e is also the electric intensity. Further, the magnetic intensity H is given by $\frac{2i}{r}$, where r is the radius of the wire. Now e is directed along the wire, and H at right angles to it, and the quantity $\frac{eH}{4\pi}$ therefore represents a flow of energy from the dielectric into the wire, paying regard to the left-hand law mentioned on the last page. Thus the rate at which energy enters unit length of the wire is $\frac{eH}{4\pi} \times 2\pi r$ ergs per second, where $2\pi r$ is the area of surface of unit length of wire. And since $H = \frac{2i}{r}$,

$$\text{flow of energy into wire} = \frac{e}{4\pi} \times 2\pi r \cdot \frac{2i}{r} = ei \text{ ergs per second,}$$

which is the rate of dissipation of energy in the form of heat in the wire.

It is therefore reasonable to suppose that the energy from the source of supply does not travel along the wire, but through the dielectric, entering the wire through its lateral surface. It should be noted that if the direction of e be reversed, that of i and of H are both reversed, and the direction of propagation of energy is still from the dielectric into the wire.

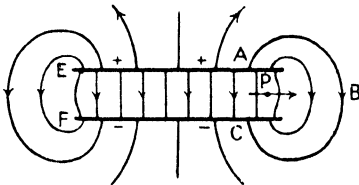

FIG. 365.

(ii) The slow discharge of a condenser affords another example of the application of the law. Let the wire ABC join the plates of the condenser (Fig. 365), and for simplicity let the direction of the wire be

everywhere parallel to the electrical intensity. As the current flows in the wire from A to B energy enters the wire as in case (i), to be there dissipated as heat. But the electric displacement in the dielectric itself is directed from the plate EA towards FC, and the magnetic field is from front to back (see Fig. 363), which would indicate, according to the law, a flow of energy parallel to the plates of the condenser from EF to AC, and at a point such as P it is travelling in the direction of the arrow towards the wire.

(iii) The current from a battery flows along the wire joining the poles; but we have seen that this consists of the positive ends of the Faraday tubes travelling from the positive pole, and the negative ends from the negative pole, the two approaching each other along the conductor as the tubes contract. The function of the battery is to furnish a continuous supply of Faraday tubes, and their mode of disappearance is similar to that in the case of the discharge of the condenser. The energy flows through the dielectric, the wire merely acting as a means of directing the motion of the ends of the tubes and converting their energy into heat.

(iv) In the case of an electromagnetic wave whose direction of propagation is parallel to a conducting surface, as in Fig. 366, the dissipation of energy in the form of heat in the conductor is zero if the conductivity be infinite, the flow of energy being in the direction of propagation of the wave, none of it entering the conductor. But if the conductor have resistance, the motion of the ends of the

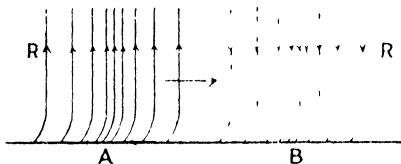

FIG. 366.

the Faraday tubes along it involves the expenditure of energy. That is energy enters the conductor, and hence the electric intensity and the Faraday tubes must be inclined to the surface of the conductor where they meet it. Application of the left-hand law now indicates that the direction of inclination is as shown in the figure, and it should be noticed that the magnetic intensity is parallel to the conducting surface, but from back to front at A, where the electric intensity R is positive, and from front to back at B, where R is negative. The resistance of the conductor has the effect of retarding the ends of the Faraday tubes, which are therefore dragged along by the rest of the tube in opposition to this retardation.

(v) An alternating electromotive force causes energy to enter the conductor whatever the direction of the electromotive force, as we saw in example (i); but during the first half-period the electromotive force may have fallen to zero, if the oscillations are sufficiently rapid, before the energy, whose velocity of propagation in the conductor is much less than in air owing to the high dielectric constant, has penetrated far into the conductor. This happens at each half-oscillation,

and explains the fact that the dissipation of energy is confined to the surface layers when the alternation is sufficiently rapid—a fact which is known as the “skin” effect, and which we studied on p. 365.

Pressure on Surface due to Incident Wave.—On meeting a plane surface normally, the wave may be transmitted, reflected, or absorbed. In general all three processes occur, but in the case of total absorption we may deduce from the conception of the Faraday tubes, which exert a lateral pressure as well as a longitudinal pull, that the wave would exert a pressure upon the absorbent surface. A surface of this kind which absorbs all the radiation falling upon it, is called a perfectly black surface, and whatever becomes of the radiation which is absorbed, it certainly ceases to be an electromagnetic wave. Thus, if the tubes of induction are destroyed as they meet the surface, we

have upon one side of the surface a lateral pressure $\frac{kR^2}{8\pi}$ due to the Faraday tubes (p. 135), which is unbalanced by any tubes on the other side. The pressure is therefore exerted on the surface itself, and since the mean value of R^2 for a whole wave is $\frac{1}{2}R_0^2$, the mean pressure exerted by the Faraday tubes is $\frac{kR_0^2}{16\pi}$. In a similar manner we have a

pressure $\frac{\mu\beta_0^2}{16\pi}$ due to the magnetic intensity. But as on p. 417 $kR_0^2 = \mu\beta_0^2$, so that the mean total pressure due to both sources is $kR_0^2 = \frac{\mu\beta_0^2}{8\pi}$, and this is equal to the energy per unit volume of the dielectric through which the wave passes.

This result may be obtained directly from the principle of the conservation of energy. Also, it was predicted by Maxwell as the result of his theory of electromagnetic radiation. He further pointed out, from the identity in magnitude of the velocity $\frac{1}{\sqrt{k\mu}}$ of plane electromagnetic waves with that of light, that light consists of electromagnetic waves of very high frequency. The actual existence of electromagnetic waves was not proved during Maxwell's lifetime, but in 1888 Hertz detected them in the neighbourhood of a circuit in which electrical oscillations were occurring.

The existence of a pressure exerted by light falling upon a material surface was demonstrated and measured by Lebedef,¹ who focussed a beam of light upon a blackened platinum surface, delicately suspended in a vessel having high vacuum. Care was taken to eliminate disturbances due to variation in temperature, and the result then indicated a pressure due to the incident beam, of the order of magnitude predicted by Maxwell.

A similar measurement was made by Nicols and Hull,² an exhaustive

¹ P. Lebedef, *Rapp. Congrès Internat. d. Phys.*, T. 2, p. 133. 1900.

² E. F. Nichols and G. F. Hull, *Proc. Amer. Acad.*, 38, p. 559. 1903.

set of experiments being carried out. A torsion balance consisting of two polished silver discs suspended by a quartz fibre is situated in an enclosure in which the gas pressure can be varied. Light from an electric arc can be directed upon either disc, and the rotation observed, the intensity of the incident radiation being measured by means of the bolometer. The most important source of error is due to the "radiometer" effect discovered by Crookes, which is of such frequent trouble in determining mechanical effects at low gas pressures. The side of the disc upon which the radiation falls, rises in temperature, and the increased velocity of the gas molecules as they rebound from this face results in an excess of pressure upon it, and this effect might be confused with that due to the direct pressure of the radiation. The "radiometer" effect is slowly established, while the radiation pressure is instantaneous, and hence the ballistic observations only are used. The radiation pressure found is in close agreement with the calculated value.

The following list of the results of the determination of the velocity of light affords further proof of the fact that light is an electromagnetic radiation, since the remarkable agreement of the mean value with that for the quantity $\frac{1}{\sqrt{k\mu}}$ obtained by the methods described in the last chapter can hardly be accidental.

Fizeau	3·150 × 10 ¹⁰ cms. per sec.
Cornu	3·004 × 10 ¹⁰ " "
Foucault	2 980 × 10 ¹⁰ " "
Michelson	2·998 × 10 ¹⁰ " "
Newcomb	2·999 × 10 ¹⁰ " "

Index of Refraction of Light.—On the wave theory of light it follows that the index of refraction of light on passage from one medium to another (n) is given by, $n = \frac{\text{velocity of light in first medium}}{\text{velocity of light in second medium}}$. Since all transparent media have a magnetic permeability very nearly equal to unity, we may put $\mu = 1$, and we then see that the velocity of a plane electromagnetic wave $\propto \frac{1}{\sqrt{k}}$, and hence if the dielectric constant of the first medium is k_1 , and that of the second k_2 —

$$n = \sqrt{\frac{k_2}{k_1}}$$

If the light is passing from air or vacuum to the substance, then $\frac{k_2}{k_1} = k$, the dielectric constant of the medium, taking that of a vacuum as unity, and we have, $n = \sqrt{k}$, or, $k = n^2$.

By the method of discharging a condenser through a ballistic galvanometer, using the gas as dielectric, Klemencic¹ found the following values of k ; the corresponding values of n^2 are given alongside of them for comparison:—

	k .	n^2
Air	1 000586	1 0005854
Hydrogen	1 000264	1 0002774
CO ₂	1 000984	1 0009088
CO	1 000694	1 0006700

The following values of k are chosen from various sources, and the corresponding values of n^2 placed with them:—

	n^2 .	k .	Observer.
Water	1 78	80 0	Cohn, <i>Wied. Ann.</i> , 38 , 1889
"		80 6	Drude, <i>Wied. Ann.</i> , 59 , 1896
CS ₂	1 99	2 64	Drude, <i>Zeit. Phys. Chem.</i> , 23 , 1897
Paraffin	2 02	2 14	Thwing, <i>Zeit. Phys. Chem.</i> , 14 , 1894
Sulphur	4 47	2 4	J. J. Thomson, <i>Proc. Roy. Soc.</i> , 46 , 1889
Glass (crown)	2 38	3 24	Gordon, <i>Phil. Trans.</i> , 170 , 1879
Glass (light flint)	2 53	3 01	" " "

It will be noticed that in many cases the agreement between n^2 and k is good, but in others, particularly in the case of water, there is an apparent want of agreement. This is probably due to the fact that the effect of absorption has been neglected, and since this may modify the refractive index profoundly, the comparison is only of value in cases where we are certain that absorption of the wave does not exist, as, for example, in the case of the gases.

General Case of Wave Propagation.—A more general solution to the equations (iii) (p. 409) and (iv) (p. 410) may be obtained by differentiating (iii) with respect to t , and then eliminating P, Q, and R by means of (iv).

Thus from the first of equations (iii)—

$$\mu \frac{d^2 \alpha}{dt^2} = \frac{d^2 R}{dy dt} - \frac{d^2 Q}{dz dt}$$

Now, from the second and third of equations (iv)—

¹ I. Klemencic, *Sitzungsber. Wien. Akad.*, **91** (2), p. 712. 1885.

$$\begin{aligned}
 -k \frac{d^2 Q}{dz dt} &= \frac{d^2 a}{dz^2} - \frac{d^2 \gamma}{dx dz} \\
 -k \frac{d^2 R}{dy dt} &= \frac{d^2 \beta}{dx dy} - \frac{d^2 a}{dy^2} \\
 \therefore -k\mu \frac{d^2 a}{dt^2} &= \frac{d^2 a}{dx dy} - \frac{d^2 a}{dy^2} - \frac{d^2 a}{dz^2} + \frac{d^2 \gamma}{dx dz} \\
 \text{or,} \quad k\mu \frac{d^2 a}{dt^2} &= \frac{d^2 a}{dy^2} + \frac{d^2 a}{dz^2} - \frac{d^2 \beta}{dx dy} - \frac{d^2 \gamma}{dx dz}
 \end{aligned}$$

But differentiating the second equation of (i) (p. 407) with respect to x ,

$$\frac{d^2 a}{dx^2} + \frac{d^2 \beta}{dx dy} + \frac{d^2 \gamma}{dx dz} = 0,$$

and substituting we get,

$$k\mu \frac{d^2 a}{dt^2} = \frac{d^2 a}{dx^2} + \frac{d^2 a}{dy^2} + \frac{d^2 a}{dz^2}$$

which is usually written, $k\mu \frac{d^2 a}{dt^2} = \nabla^2 a$. Similar equations may be obtained for β and γ ; and further, by differentiating any one of equations (iv) with respect to t and making use of equations (iii), we find that $k\mu \frac{d^2 P}{dt^2} = \nabla^2 P$, with similar equations for Q and R .

A solution of the type

$$P = f_1(lx + my + nz - vt) + f_2(lx + my + nz + vt)$$

may be found for these equations, in which l, m , and n are the direction cosines of the normal to the plane

$$lx + my + nz = p,$$

p being the length of the normal between the origin and the plane,

and $v^2 = \frac{1}{k\mu}$. Hence the possibility of the propagation of a plane

wave in any direction, with velocity $v = \frac{1}{\sqrt{k\mu}}$.

This general form is of great use in the theory of light, and for a further development of it the student is referred to works on optics.

Oscillatory Discharge.—We have already seen that the equation for the electromotive forces occurring in a conductor which has capacity and inductance, leads to the conclusion that any change in the electrical condition of the conductor is accompanied by oscillations when

$\frac{L}{C} > \frac{R^2}{4}$ (p. 334), and that the time of one complete oscillation is

$\frac{2\pi}{\sqrt{\frac{1}{LC} - \frac{R^2}{4L^2}}}$ (p. 336), which reduces to $2\pi\sqrt{LC}$ when R is small.

We are now in a position to interpret this process in terms of the Faraday tubes and their motion in the surrounding dielectric. If the circuit consist of two conductors A and B separated by a small air gap, and A have a negative and B a positive charge, the distribution of the electrical field will be somewhat as shown in Fig. 367 (i), the lines indicating Faraday tubes of induction, the tubes on one side only

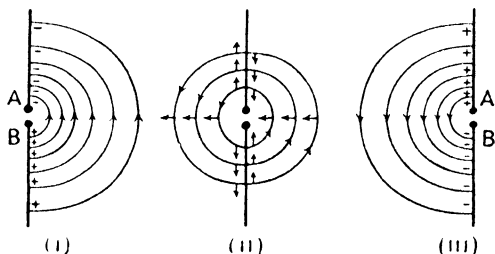

FIG. 367.

being drawn. On increasing the charges upon A and B, the difference of potential between them will rise until a certain limit is reached depending upon the length of the gap, the nature of the electrodes, and the pressure of the air. As soon as this limit is reached, the gap suddenly becomes conducting, and the negative ends of the tubes situated upon A move downwards, those upon B moving upwards, both constituting a positive electric current flowing upwards.

If the tubes did not possess inertia they would all in turn collapse in the gap, those at the outside shrinking to fill the space previously occupied by those which have disappeared, and there would be no oscillation. But the Faraday tubes in motion are accompanied by a magnetic field, and, as was shown by Sir J. J. Thomson (p. 414), the magnetic field at right angles to their length and to their direction of motion being given by $H = 4\pi DV \sin \theta$, where θ is the angle between the tube and its direction of motion.

Now, the magnetic field H is associated with an amount of energy equal to $\frac{\mu H^2}{8\pi}$ per unit volume,

$$\text{i.e. } \frac{16\pi^2 D^2 V^2 \mu \sin^2 \theta}{8\pi} = 2\pi\mu D^2 V^2 \sin^2 \theta$$

and this is consequently the energy of the Faraday tubes due to their velocity V . By analogy with the expression $\frac{1}{2}mv^2$ for the kinetic energy of a moving body of mass m , we may imagine the tubes to be endowed with mass $4\pi\mu D^2 \sin^2 \theta$ per unit volume, and their momentum would therefore be $4\pi\mu D^2 V \sin^2 \theta$ when moving with velocity V at

an angle θ to their length. Thus the mass per unit volume is zero when moving in their own direction, for $\theta = 0$, and $4\pi\mu D^2$ when moving at right angles to their length.

The conception of the Faraday tube has been developed for the purpose of explaining the attractions and repulsions between electrical charges, the tension along the tube tending to pull together the opposite charges at the ends, and the lateral pressures between contiguous tubes pushing like charges apart. These lateral pressures, however, can only exist when the neighbouring tubes have the same direction. To account completely for the phenomena, we must imagine that oppositely directed tubes attract each other and may even coalesce on meeting. Thus if two pairs of charges AB and CD be placed at a distance apart upon two conductors as in Fig. 368 (i), although a few

Faraday tubes may exist between A and C, and B and D respectively, yet the greater number will exist between A and B, and C and D. Yet the charges A and C approach and neutralise each other, as will B and D. The process may be looked at from two points of view. Either the few tubes between A and C pull the charges together, shrinking in the process and eventually disappearing, as also do those between B and D, in which case the tubes from A to B, and from D to C eventually coincide in position and have a zero resultant; or we may consider that the two sets of tubes, being oppositely directed, attract each other. When the approaching tubes meet they coalesce and break up into tubes joining AC and BD respectively, as at *e* and *f* (Fig. 368, (ii)); these then shrink and eventually disappear. The result is the same on either supposition; the charges have met and neutralised each other, there having been no metallic connection at any time between the two conductors.

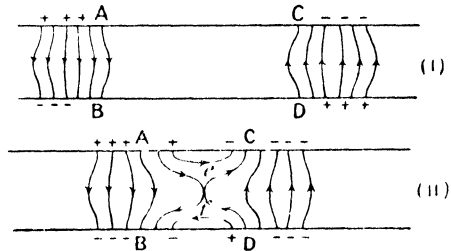

FIG. 368.

together, shrinking in the process and eventually disappearing, as also do those between B and D, in which case the tubes from A to B, and from D to C eventually coincide in position and have a zero resultant; or we may consider that the two sets of tubes, being oppositely directed, attract each other. When the approaching tubes meet they coalesce and break up into tubes joining AC and BD respectively, as at *e* and *f* (Fig. 368, (ii)); these then shrink and eventually disappear. The result is the same on either supposition; the charges have met and neutralised each other, there having been no metallic connection at any time between the two conductors.

If, however, the charges approach each other with the velocity of propagation of an electromagnetic wave, the state of affairs is different. Each moving set of tubes has its accompanying magnetic field, and since the tubes are oppositely directed and their velocities are also opposite, their magnetic fields coincide in direction, being directed through the plane of the paper from front to back in Fig. 368. The energy still exists in the form of the magnetic field even at the instant that the charges and Faraday tubes are neutralising each other. Thus each still has its own momentum, and the two will cross and then recede from each other with undiminished velocity.

If two sets of Faraday tubes having the same direction be approaching

each other, their magnetic fields as the two waves approach will be oppositely directed and give zero magnetic field at the instant of coincidence. But the electrical charges and displacements are in this case doubled at this instant owing to the coinciding of the two sets, and the energy in this case persists in the form of the electrical field. This gives rise to two equal waves which recede from each other with equal velocities, and we may to all intents and purposes say that the two waves have crossed each other and passed on, each unaffected by the other. Hence we may consider that when travelling, the Faraday tubes, having inertia on account of their accompanying magnetic fields, can cross each other, each passing on unaffected by the other.

Returning to the consideration of Fig. 367, we see that when the gap becomes conducting, the lateral pressure on the tubes near the gap due to those lying outside, will cause them to travel inwards, the ends lying upon A travelling downwards, and those upon B upwards, but every part of the tube, since it arrives at the gap with velocity, and therefore momentum, will continue to travel onwards, and the ends will cross each other at the gap, the positive ends will travel up A, and the negative ends down B, the tube meanwhile spreading out on the other side of AB. The state of affairs when half the tubes have crossed the gap is shown in Fig. 367 (ii), and all the tubes there drawn are at this instant travelling from right to left. The process will continue until all the tubes have crossed. They will come to rest as in Fig. 367 (iii) when their momentum has been reduced to zero by the stresses in the tubes, which will now tend to drive them to the right. A is now positively charged and B negatively; in fact, the current has flowed from B to A until this reversal has been effected. The current then ceases, and is ready to begin the reverse flow if the gap is still conducting. For the purpose of clearness only half the field has been drawn in the diagram, but it will readily be seen that the actual state of the field will be obtained by revolving the figure about AB. In (ii) the tubes which at the start were on opposite sides of AB are now half on each side, and the value of D , or the resultant number of tubes per unit area, is zero, since the tubes have reversed their direction on passing the gap. The resultant electrical charge and displacement at this instant are everywhere zero; but it must be remembered that the two sets of tubes at any point have opposite velocities as well as directions, and therefore the magnetic fields corresponding to them are coincident in direction, and their resultant is obtained by adding the two together. They are therefore circles surrounding AB, and the energy of the charge is now in the form of the magnetic field. The direction of the magnetic field is that due to the current flowing upwards in AB.

As the current surges backwards and forwards between A and B the energy of the system alternates between the electrostatic and magnetic forms, and if the former be compared to potential energy the latter is

kinetic, and the energy of the system, like that of a mechanical vibrating system, alternates between the static and the kinetic forms.

The presence of the air gap is not essential to the above discussion ; if positive and negative charges be simultaneously given to two ends of a conductor, or even if only one charge be given at a point of it, the redistribution of the charge will be accompanied by surgings backwards and forwards, which will be eventually damped out on account of the resistance of the conductor itself to the passage of the current through it, and the energy of the vibration will gradually be dissipated in the form of heat in the conductor.

Rapid Oscillations and Radiation.—Provided that the oscillations are sufficiently slow, the energy is entirely transformed into heat in the conductor, none of it passing permanently into the surrounding dielectric, but with rapid oscillations this is no longer true.

Starting with a shorter conductor, which will of course have less capacity and inductance, the lines on one side of it at the moment at

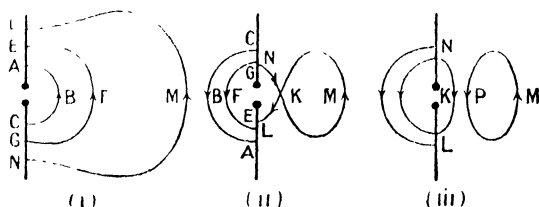

FIG. 369.

which the gap begins to be conducting will be represented by Fig. 369 (i). When the discharge begins, the ends of the tubes near the gap will cross ; the tubes become reversed, exactly as in the previous case. A tube such as ABC (Fig. 369, (i)) will be reversed on reaching the gap, and will spread out upon the other side, on account of its own inertia and the pressure of the tubes behind it, whereas the ends L and N of a tube such as LMN will reach the gap before the equatorial part M, and will cross, as at K (Fig. 369) (ii). A stage in the process will be reached when the branches LKM and NKM at the point of intersection, are moving parallel to their own directions, and they have then no momentum to carry them past each other and coalescence occurs, the tube separating into a closed loop PM and a half loop LKN (iii) with ends upon the conductor, which continues to grow, owing to the momentum of the parts of the tube at L and N. This part of the tube will cease to grow when its own tension and the pressure of the neighbouring tubes have exhausted its momentum.

There will be some limiting tube EFG, such that those within it cross to the other side of the conductor, while those lying outside it will form loops and will not pass the conductor.

We are now in a position to understand the processes going on when radiation occurs

Starting with the Faraday tubes as shown in Fig. 370 (i), those to the right of AB at the start are drawn in full line, and those to the left dotted. A has a negative and B a positive charge at the moment at which the gap becomes conducting. In (ii) the first two tubes have crossed the gap and will afterwards continue to expand until the first half-oscillation is complete. At (iii) the ends of the third tube have met at the gap before the equatorial part reaches it, and the ends cross,

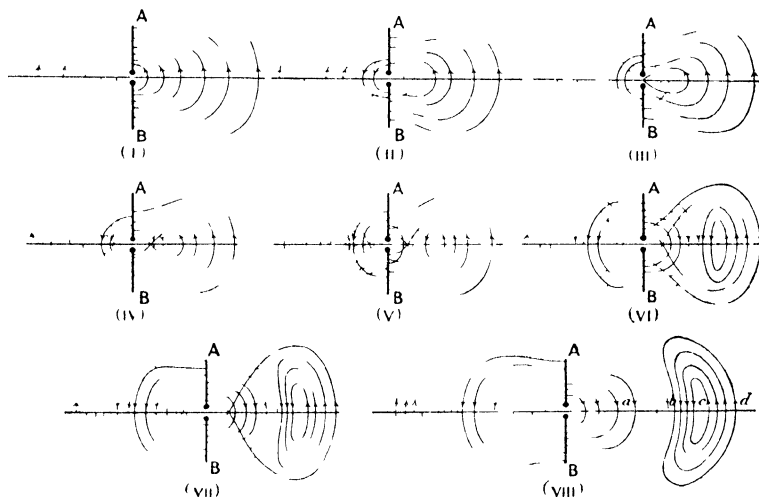

FIG. 370.

forming a loop, as at (iv). At (v) the third line has broken into two parts forming the closed loop, and the fourth line is in the act of breaking. In (vi), (vii), and (viii) the process is continued, and the remaining tubes form closed loops.

As each tube breaks, the tension in each part of it causes a pull which brings the closed part into the space between the two tubes which have crossed from the other side and the loop immediately inside it, and the remainder which has its ends upon the conductors is similarly pulled to the inside of the adjacent tube. Whether the tubes are supposed to cross each other, or whether they reach their final state by frequent coalescences between neighbouring tubes with reseparation in their new form, is immaterial, as we saw on p. 425.

The closed loops, immediately after their formation, are pushed outwards by the expanding tubes behind them, and when the condition represented in (viii) is reached, the loops are travelling outwards and

will now continue to travel with the velocity $\frac{1}{\sqrt{k\mu}}$. In the next half-oscillation a second set of loops of reverse sign will be pushed outwards; the whole set will, as they spread outwards, become cylindrical sheets which on expanding, continually approximate to planes of electrical displacement normal to the line joining them to the middle of the oscillator. Those parts of the loops that travel away from the equatorial plane need not here concern us.

Relative Phases of Electrical and Magnetic Fields.—We have already seen (p. 416) that in an electromagnetic wave, the magnetic field is in phase with the electric displacement, that is they both reach their maximum values and their zero values simultaneously. Thus at points such as *b* (Fig. 370 (viii)) the magnetic field and the electric displacement have their maximum values, at *c* they are both zero, and at *d* they again have maximum values, but of opposite sign to those at *b*. At the oscillator the magnetic field and the electrical displacement are 90° apart in phase; that is, one has its maximum value when the other is zero, as we saw on p. 426. Hence between the oscillator and the point *b* one of them has been displaced 90° in phase relatively to the other. It will be seen that the phase of the electrical displacement is the same at *b* as at the oscillator, and therefore in calculating the phase of the electromagnetic wave at a distant point at any instant, the distance of the point from *b* must be used, and not the distance from the oscillator. This fact bears a remarkable analogy to the quarter wave-length discrepancy that occurs when calculating the phase of the light vibration due to a plane wave of light, at a point in advance of the wave-front. On splitting up the wave front into Fresnel's zones, it is found that the resultant effect of the wave is that due to half the first Fresnel's zone at the pole of the wave, but to get the correct phase, the wave-front must be imagined to be *displaced forward by a quarter of a wave-length*. The analogy between this case and that of the electromagnetic oscillator was pointed out by Professor F. T. Trouton,¹ and he calculated from Hertz's equations that the phases of the magnetic field and electric displacement at a distance from the oscillator are correct, if the distance be measured from the point *b* and not from the oscillator, when the distance from the oscillator to *b* is $\frac{\lambda}{4}$, λ being the wave-length of the disturbance at a distance from the oscillator.

We may get some idea of the reason for this change in the relative phases of the field and displacement by drawing a curve for each, for the positions *a*, *b*, *c*, *d* in Fig. 370 (viii). At the oscillator the displacement has reached its negative maximum value, and is for an instant stationary, and from *O* to some point between *a* and *b* the Faraday tubes are on the point of beginning to return for the second

¹ F. T. Trouton, *Phil. Mag.* (Ser. 5), 29, p. 268. 1890.

half-oscillation, but at b they are moving outwards. At c there is zero, and at d the maximum positive displacement. The full-line curve D in Fig. 371 represents the distribution of displacement. The magnetic

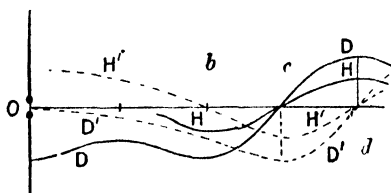

FIG. 371.

field is zero where the tubes are at rest; but increases in value between a and b , reaching at b a maximum. At c it is zero, and at d again a maximum. Its distribution is represented by the full-line curve H .

A quarter of a period later the condition is represented by the dotted curves D' and H' in

Fig. 371. Near the oscillator there is a magnetic field due to the motion of the Faraday tubes towards it, while at b the field is zero. The maximum previously at b has reached c , and is in phase with the displacement. The succeeding oscillations then produce a train of electromagnetic waves of the ordinary type travelling outwards from b .

Reflection of Plane Waves.—In the case of the oscillator, we have seen that some of the Faraday tubes of the surrounding field, instead of passing the conductor when they collapse upon it, are reflected. A similar reflection occurs when plane electromagnetic waves meet a conducting surface. For simplicity we will consider a plane electro-

magnetic wave of the type described on p. 413, falling normally upon a perfectly conducting surface.

Let the equation to the electrical displacement be

$$R = R_0 \sin 2\pi \left(\frac{x}{\lambda} + \frac{t}{T} \right).$$

From p. 412 we see that this is a wave travelling towards the origin with velocity $v = \frac{\lambda}{T}$.

The magnetic field is then obtained from the relation $\mu \frac{d\beta}{dt} = -\frac{dR}{dx}$ (p. 411); *i.e.*—

$$\frac{d\beta}{dt} = -\frac{2\pi R_0}{\mu\lambda} \cos 2\pi \left(\frac{x}{\lambda} + \frac{t}{T} \right),$$

and,

$$\begin{aligned} \beta &= -\frac{TR_0}{\mu\lambda} \sin 2\pi \left(\frac{x}{\lambda} + \frac{t}{T} \right) \\ &= -\beta_0 \sin 2\pi \left(\frac{x}{\lambda} + \frac{t}{T} \right), \end{aligned}$$

where $\beta_0 = \frac{T}{\mu\lambda} R_0$.

The curves for R and β are drawn in Fig. 372 for the instant

when $t = \frac{T}{4}$, and the wave is completely represented by the motion of the curves A and C from right to left with velocity $v = \frac{1}{\sqrt{k\mu}}$.

If then YOZ be a perfectly conducting plane, the electric intensity in this plane must always be zero. Hence in the plane itself some electric intensity is brought into play which is equal and opposite to R at every instant, for otherwise there would be a result intensity

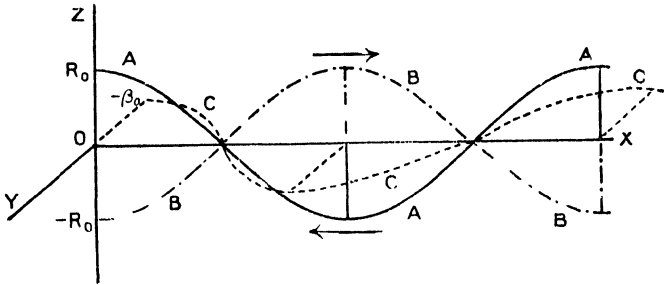

FIG. 372.

differing from zero. The electric intensity at the plane is obtained by putting $x = 0$ in the equation for R, whence $R = R_0 \sin 2\pi \frac{t}{T}$, and this opposite intensity created in the conducting plane is therefore $R = -R_0 \sin 2\pi \frac{t}{T}$.

A harmonic disturbance such as this gives rise to two sets of waves, one travelling to right and one to left from the point. The one to the left is $R = -R_0 \sin 2\pi \left(\frac{x}{\lambda} + \frac{t}{T} \right)$, and is in the direction of the incident wave, and by comparing the equations for the two, we see that the two waves entirely cancel each other out, and there is no effect beyond the conducting plane. This is just as we should expect, for a perfect conductor is opaque to electromagnetic radiation. The other wave, travelling to the right, has the equation $R = R_0 \sin 2\pi \left(\frac{x}{\lambda} - \frac{t}{T} \right)$, for this reduces to $R = -R_0 \sin 2\pi \frac{t}{T}$ at the plane, and has the form of a wave travelling to the right.

The instantaneous intensity R at the conducting plane will give rise to a current in it, whose accompanying magnetic field is β , and is in the direction given by Fig. 363. It must be remembered that in Figs. 362 and 372, the direction of the axis OY is arbitrarily chosen,

but whatever direction for the axis is chosen, the actual positive direction of the magnetic field must always be in accordance with that in Fig. 363.

In a similar manner, the magnetic field β , meeting the plane, gives rise to an electric intensity R in it. For a strip of unit width parallel to OZ will, for every unit length of the strip, be cut by magnetic induction at the rate $\mu\beta v$ units per second, and this is equal to the electromotive force in it.

$$\begin{aligned} \text{But,} \quad \beta &= -\frac{T}{\mu} \cdot \frac{R_0}{\lambda} \sin 2\pi\left(\frac{x}{\lambda} + \frac{t}{T}\right) \\ &= -\frac{T}{\mu\lambda} \cdot R. \end{aligned}$$

$$\begin{aligned} \text{Now, } \frac{\lambda}{T} &= v, \text{ and E.M.F.} = \mu\beta v \\ &= \frac{T}{\mu\lambda} \cdot v\mu R = R. \end{aligned}$$

The probable reason for the reverse electric intensity produced in a conducting plane when the wave meets it will be suggested later (p. 538), when we consider the electronic theory of conduction in metals.

Another way of looking at the process of reflection is to consider that as the Faraday tubes arrive at the conducting plane, their ends on reaching the plane travel together, and the tube becomes reversed on account of its inertia. The magnetic field is not reversed, so that by Poynting's Theorem (p. 417) the direction of propagation of energy is reversed; that is, the wave now travels away from the plane. The reflected wave is represented at the instant $t = \frac{T}{4}$ by the curves C and B (Fig. 372), the curve C at the given instant being the same for both incident and reflected waves, for the accompanying magnetic field β to the wave $R = R_0 \sin 2\pi\left(\frac{x}{\lambda} - \frac{t}{T}\right)$ is, as we have seen on p. 414—

$$\beta = \beta_0 \sin 2\pi\left(\frac{x}{\lambda} - \frac{t}{T}\right)$$

and is in phase with the magnetic field of the incident wave at the plane, since here $x = 0$. For this reflected wave which is travelling to the right, β and R have the same sign, and it may be noticed that for the incident wave which is travelling to the left, β and R have opposite signs; this also gives us a means of determining the direction of propagation of the wave, and is in accordance with Poynting's theorem. It should be remembered that Fig. 372 is drawn for the epoch $t = \frac{T}{4}$.

If the conducting plane be divided into strips by a number of parallel non-conducting lines, the reflection of the wave is unaffected when these strips are parallel to the direction of R , since the conductivity in the direction of R is unchanged, but when at right angles to R , the wave as it meets the plane cannot produce any current. In fact, it is now non-conducting in the direction of the electromotive force, if the strips are sufficiently narrow, and reflection will not occur. We shall see later that Hertz used a metallic grating, and found that when the metallic strips are parallel to the electric displacement, reflection occurred, but not when they are at right angles to it; the waves in this case are transmitted. It will be seen that such a grating behaves towards an electromagnetic wave exactly as a Nicol's prism behaves towards light. Two such gratings may be used as polariser and analyser respectively.

Stationary Oscillation.—We should expect, from analogy with the case of sound waves and waves in stretched strings, that the two waves, the incident and the reflected ones described above, would combine to produce a condition of steady oscillation.

If we find the resultant electric intensity due to both incident wave $R = R_0 \sin 2\pi \left(\frac{x}{\lambda} + \frac{t}{T} \right)$, and reflected wave $R = R_0 \sin 2\pi \left(\frac{x}{\lambda} - \frac{t}{T} \right)$, we have—

$$\begin{aligned} R_1 &= R_0 \left\{ \sin 2\pi \left(\frac{x}{\lambda} + \frac{t}{T} \right) + \sin 2\pi \left(\frac{x}{\lambda} - \frac{t}{T} \right) \right\} \\ &= 2R_0 \sin 2\pi \frac{x}{\lambda} \cos 2\pi \frac{t}{T}. \end{aligned}$$

This represents a condition of steady oscillation in electrical condition, for at any given point, x is constant and the oscillation is harmonic of the type $R_1 = A \cos 2\pi \frac{t}{T}$, and it will be seen that the phase is now independent of x . The amplitude A itself varies with x according to the equation $A = 2R_0 \sin 2\pi \frac{x}{\lambda}$. It is therefore zero at the reflecting

surface, and reaches its maximum value, $2R_0$, at a distance $\frac{\lambda}{4}$ from the surface. The successive values of R during half an oscillation are indicated by curves 1, 2, 3, 4, 5 in Fig. 373 (i).

The value of β at any point is similarly obtained by adding the values for the incident and reflected waves—

$$\begin{aligned} \beta_1 &= -\beta_0 \left\{ \sin 2\pi \left(\frac{x}{\lambda} + \frac{t}{T} \right) - \sin 2\pi \left(\frac{x}{\lambda} - \frac{t}{T} \right) \right\} \\ &= -2\beta_0 \cos 2\pi \frac{x}{\lambda} \sin 2\pi \frac{t}{T}. \end{aligned}$$

This is also the equation of a stationary oscillation, whose amplitude is $2\beta_0$, where $x = 0$, that is at the reflecting surface, and also at points $x = \frac{\lambda}{2}, \lambda, \frac{3\lambda}{2}$, etc., whereas it is zero at points $x = \frac{\lambda}{4}, \frac{3\lambda}{4}, \frac{5\lambda}{4}$, etc. The curves in Fig. 373 (ii) indicate the variation in β_1 during a half-oscillation; but it must be remembered that the direction of β_1 is at

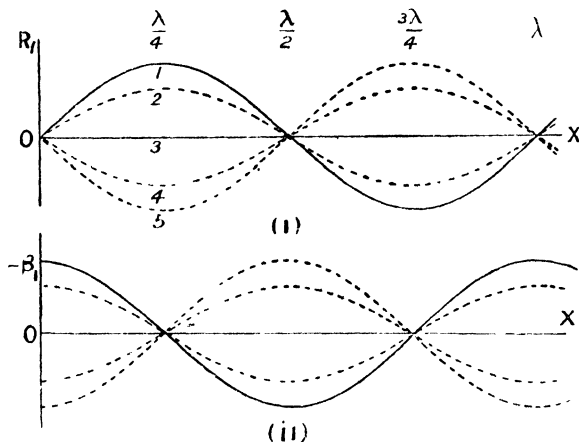

FIG. 373.

right angles to that of R_1 ; the ordinates in the diagrams merely represent to scale the respective values of β_1 . By comparing (i) and (ii) we see that for points where the fluctuation in R is a maximum, the fluctuation in β is zero, and *vice versa*.

Parallel Wires.—On connecting one end of each of a pair of parallel wires to the terminals of a condenser in which an oscillation in electrical condition is occurring (see p. 428), electromagnetic waves are produced which travel down the wires. The waves are not in this case plane, the ends of the Faraday tubes being confined to the wires in a manner similar to that for the parallel planes described on p. 414. Although the actual shape of the wave is not easily determined, the process of propagation is like that which we have been considering, and if the far ends of the wires are joined together, reflection will occur there. If the ends are not joined by a conductor, a discharge may occur with production of brushes or sparks, the effect being to produce a reflected wave, although in this case some of the energy of the wave is lost at the point of reflection. Sir Oliver Lodge¹ has shown, by means of two such parallel wires with their near ends connected respectively to the inner and outer coatings of a Leyden jar, that, taking the length of the

¹ O. J. Lodge, *Phil. Mag.* (Ser. 5). 26, p. 217. 1888.

wires when maximum spark occurs at the free ends to be half the wave-length of the electromagnetic oscillation, the velocity of propagation obtained by multiplying this wave-length by the frequency of oscillation of the jar as calculated from its dimensions, is about that of light-waves.

The arrangement of parallel wires was afterwards improved by Lecher, and is described on p. 458.

Velocity of Propagation.—The velocity of propagation of an electromagnetic disturbance has been directly determined by Blondlot,¹ who used two pairs of cylindrical condensers in parallel, one pair being short circuited by an air-gap, and the other discharging through the same air-gap, but the charge having to pass on the way through two long wires, PLC and QMD (Fig. 374). The insides of two glass cylinders are completely covered with tinfoil, and on the outsides are two pairs of rings of tinfoil, AB and CD. These are joined by moistened threads of high resistance shown by dotted lines in the diagram. When a spark passes at S, A and B immediately discharge, giving a spark between the points P and Q. C and D also give a spark, but the charges have to pass through the long wires CLP and DMQ, each of length 1029 metres, the spark therefore occurring later than that due to A and B. The interval between the sparks is obtained by measuring the distances between their images upon a photographic plate, produced by a rotating concave mirror, and is the time taken for the electromagnetic wave to travel a distance of 1029 metres along the wire. In this way the velocity of propagation was found to be 2.96×10^{10} cms. per second, and a second set of experiments with wires 1821.4 metres long gave 2.98×10^{10} cms. per second.

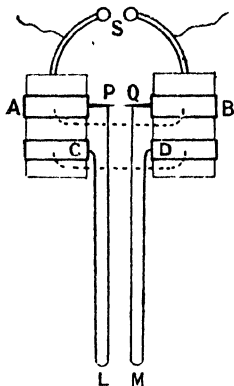

FIG. 374.

Hertz's Experiments.—The prediction by Lord Kelvin in 1853, from mathematical reasoning, that the discharge of a Leyden jar would under certain conditions be oscillatory (p. 334), was followed in 1857 by the demonstration of such oscillations by Peddersen on examining the spark in a rotating mirror. In 1865 Maxwell published his theory of electromagnetic radiation, but it was not until 1888 that Professor H. Hertz² proved the existence of such radiations in the space surrounding a Leyden jar in which electrical oscillations were occurring.

The variety of oscillators used for the production of electromagnetic waves is very great, but one of the earliest forms, used by Hertz himself, consists of two square sheets of metal, having sides

¹ R. Blondlot, *Comptes Rendus*, 117, p. 543. 1893.

² H. Hertz, *Nature*, 39, pp. 402, 450, 547 (1890); and *Wied. Ann.*, 1, 1880.

40 cms. in length, placed about 60 cms. apart, and having two gilt and highly polished balls 2 or 3 cms. apart and connected to the plates by light metallic rods (Fig. 375). The plates are connected to the terminals of an induction coil, and every time the difference of potential between the balls reaches a sufficient value to render the air in the gap conducting, an oscillatory discharge occurs, with radiation of electromagnetic waves. The balls must be kept highly polished, or the beginning of the discharge will not be sufficiently abrupt for the production of radiation.

The period of oscillation (T) of this apparatus is about 1.8×10^{-8} second, and the velocity of propagation (v) being 3×10^{10} cms. per second, we see that the wave-length (λ) given by $\lambda = vt$, is 5.4×10^2 cms., or 5.4 metres.

In order to detect the radiation, Hertz employed a circle of wire 35 cms. in radius, with a gap at one point, and here sparks occur when

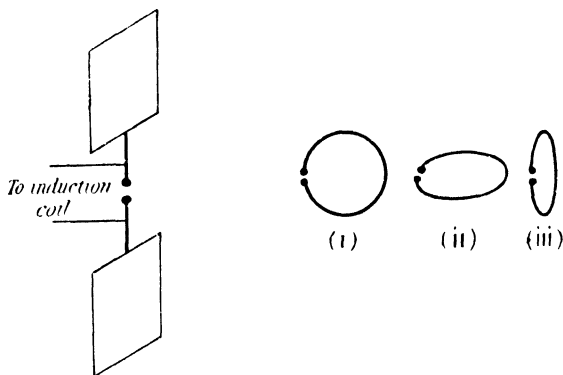

FIG. 375.

the radiation is falling upon the detector in a suitable manner. The detector itself has a proper period of its own for oscillation of charge between the knobs. If opposite charges be given to the two knobs of the detector, the Faraday tubes will contract, the two ends travelling round the circular conductor to meet each other. They will therefore, on account of their inertia, cross at the opposite end of a diameter to the gap, and then grow in the reverse direction until the charges on the ends have become completely reversed. If the period of oscillation for the detector is equal to that of the electromagnetic waves falling upon it, the Faraday tubes of the next half-wave will, on reaching the gap, cause the knobs to be oppositely charged; or we may use the alternative explanation that the magnetic field at right angles to the gap, as it travels across it, will produce an electromotive force between the knobs. Then the reversal of the charge is just completed at the instant when the

next half-wave of radiation arrives, and this will assist the reversed charging of the knobs, and the next half-oscillation will be more violent than the last. Or, to borrow an expression from acoustics, the detector resounds to the waves, or resonance occurs. This type of detector is therefore called a resonator. Sir O. Lodge has suggested the word "syntony" to replace "resonance," as this avoids confusion with the use of the word employed in acoustical problems.

In using a given detector, the position of the knobs is adjusted until maximum sparking between them occurs. The period of its proper oscillation is then the same as that of the incident wave.

The orientation of the resonator is of importance, since the electromagnetic wave is polarised, that is, the electrical displacement is, for points in the equatorial plane, in one direction only—parallel to the gap of the oscillator. The gap of the resonator must be parallel to this direction, and thus the resonator will detect the oscillations when in positions (i) and (iii), but not when in position (ii).

Refraction of Waves.—Using a reflector consisting of a metal sheet bent into a parabolic form with the oscillator in the focal line, the waves may be restricted to a comparatively narrow beam in which the wave front is plane. A similar reflector with resonator in its focal plane is used as a detector. The beams consist of polarised waves, as may be shown by placing the reflectors first with their focal lines parallel, and then with them at right angles. In the former case sparking of the resonator occurs, but not in the latter. With such an arrangement Professor Trouton repeated many of the ordinary optical experiments, using prisms of pitch or paraffin wax, and determining the index of the refraction for these materials. Using a paraffin wall 3 feet in thickness he showed¹ that reflection takes place for all angles of incidence, provided that the electric displacement in the beam is perpendicular to the plane of incidence, but when the electric displacement is in this plane, there is some angle of incidence for which reflection does not occur. Hence the electric displacement is perpendicular to the plane of polarisation, according to its optical definition.

Determination of Wave-Length by Stationary Oscillations.—By means of apparatus of the kind described on p. 436, Hertz demonstrated the existence of stationary oscillations of the type described on p. 434. The radiation was allowed to fall on a large plane sheet of zinc, at which reflection occurs, and the incident and reflected waves together form a steady vibration. It was found that as the resonator is moved outwards from the sheet, it goes through a series of maximum and minimum excitation, the maxima corresponding to points at distances $\frac{\lambda}{4}$, $\frac{3\lambda}{4}$, etc., from the sheet, and the minima to points $\frac{\lambda}{2}$, λ , $\frac{3\lambda}{2}$, etc. (Fig. 373 (i)).

¹ F. T. Trouton, *Nature*, 39, p. 391. 1889.

In this way the wave-length of the emitted waves could be determined, and knowing the frequency of oscillation, the velocity of propagation was found. With a periodic time of about 1.8×10^{-8} seconds, the minima are about 2.7 metres apart. This, being half the wave-length, gives a velocity of propagation of about 3.0×10^{10} cms. per second.

The interpretation of these experiments is not quite satisfactory. It was pointed out by Sarasin and De la Rive¹ that the distance between the nodes in Hertz's experiments depends rather upon the time of natural oscillation of the detector than upon that of the oscillator. The oscillator being of the "open" type (p. 443), the oscillations are highly damped, only a very few complete waves being emitted at each discharge. Hence no interference between the incident and reflected waves could be expected; but these waves serve to start oscillations in the detector, which, being of the "closed" type, will emit waves very slightly damped (p. 449), and if the distance from the detector to the reflecting wall be an odd number of quarter wave-lengths the reflected wave will be in the right phase to reinforce the vibration. The distance between successive points of maximum disturbance or of minimum disturbance (nodes) will therefore be $\frac{\lambda}{2}$. When the detector is syntonised with the oscillator, the effect will be as found by Hertz.

Various Oscillators.—Many other forms of oscillator have been used. Sir Oliver Lodge² tuned two Leyden jars to the same period of

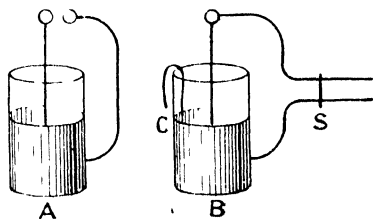

FIG. 376.

oscillation by altering the position of the slider S, which makes contact with the parallel wires connected respectively to the inner and outer coatings of the Leyden jar B (Fig. 376). When sparks occur between the knobs of the jar A the electromagnetic waves emitted set up surgings of the charge in B, which, since B is short-circuited by means of S,

will grow until the alternating difference of potential between the coatings is sufficient to cause minute sparks to occur at the short air gap C.

Lodge³ has also obtained oscillations in a single metallic sphere 5 cms. in diameter; they may, however, be much more easily obtained in the case of larger spheres. Minute sparks may be obtained from a similar sphere several yards away, on bringing a conductor into contact with it at the ends of a suitable diameter.

It has been shown by Sir J. J. Thomson, that the oscillation from pole to pole of a charge upon a conducting sphere causes radiation

¹ Sarasin and De la Rive, *Comptes Rendus*, 112, p. 658. 1891.

² O. J. Lodge, *Nature*, 41, p. 368. 1890.

³ *Ibid.*, p. 163. 1890.

whose wave-length is 1.4 times the diameter of the sphere. In the case of a sphere of diameter 5 centimetres, the wave-length of the radiation emitted is therefore 7 cms. The radiation corresponding to visible light is about 0.00006 centimetre in wave-length, and that to the longest radiant heat in the solar spectrum about 0.001 centimetre, while the shortest electromagnetic radiations that have been detected have a wave-length of about 0.3 centimetre. The gap between the two has not yet been bridged, but the conductor that would emit electrical oscillations of the length of light-waves is of molecular dimensions. There is very little doubt that the radiation emitted by an electromagnetic oscillator is of the same character as light, the difference being merely in wave-length and frequency.

Signalling by Electromagnetic Waves.—The work of Hertz and Lodge has been followed by a number of applications of the principles of electromagnetic waves to signalling, or, as it is commonly called, Wireless Telegraphy. Amongst the great number of the principal forms in which the waves have been employed, we shall only describe that which has been so largely used by Marconi, the student being referred for a comprehensive treatment of the subject to Professor Fleming's work on "Electric Wave Telegraphy."¹

By means of the induction coil, a series of discharges takes place between the knobs S (Fig. 377), and at each discharge, oscillations occur in the circuit consisting of the condenser C and one winding of the transformer T. The other winding of the transformer is in series with the long vertical conductor A, called the antenna or aerial, in which

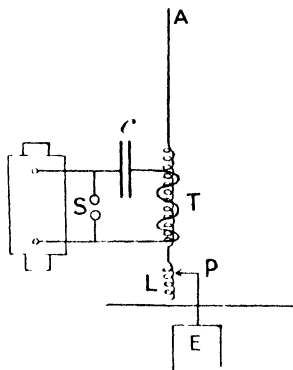

FIG. 377.

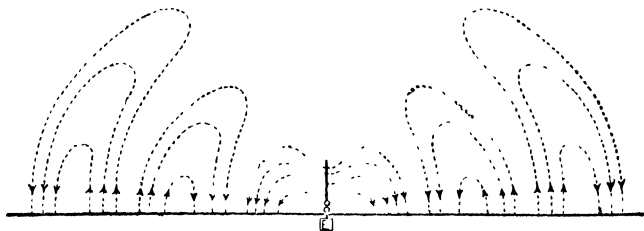

FIG. 378.

it produces an oscillating electromotive force. When the natural period of oscillation for the aerial is the same as that of the condenser circuit,

¹ J. A. Fleming, "The Principles of Electric Wave Telegraphy and Telephony." Longmans, Green & Co.

the amplitude of the oscillation in it will be very great. Hence the contact P is adjusted in position until the inductance in series with the aerial is such that the two circuits are syntonized. The antenna A is then the seat of radiation of a type similar to that from a Hertzian oscillator, but since its lower end is earthed, only the upper half of the wave of Fig. 370 is produced. A series of such waves is given in Fig. 378.

At the receiving station, the electromagnetic waves meet a similar antenna, and electric surgings in them are set up.

Detection of Electromagnetic Radiation.—In order to detect these surgings, the *coherer*, the principle of which was discovered by Sir Oliver Lodge, is used. Lodge¹ found that when electrical oscillations

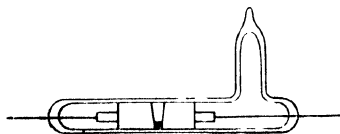

FIG. 379.

occurred between two metallic surfaces in poor contact, the resistance of the contact at once fell to a very small amount, but was immediately restored to its original value by any mechanical disturbance, such as tapping. Branly used for the same purpose a tube containing metallic filings, and this was again improved by Marconi, who used a mixture of nickel and silver filings (95% nickel) in a small gap between two

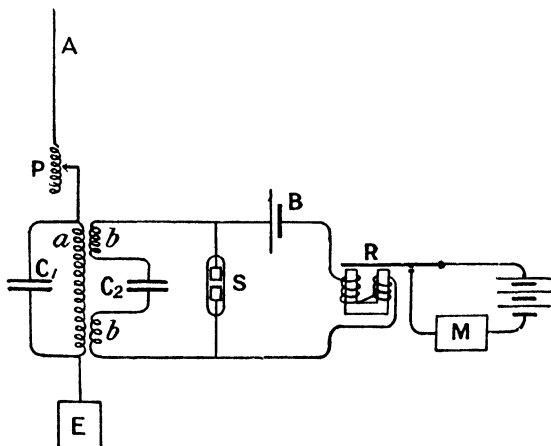

FIG. 380.

silver plugs in an exhausted and sealed glass tube (Fig. 379). A battery in series with the coherer produces a sufficient current, when the resistance of the coherer drops, to close a relay which actuates a Morse inker for recording the signals. A tapper of the form used with

¹ O. J. Lodge, *Journal I.E.E.*, 19, p. 346. 1890.

an electric bell gives a slight blow to the coherer to restore it to its original high resistance.

An arrangement of a receiving station is given in Fig. 380. By means of an inductance and sliding contact, P, the antenna circuit is tuned to sympathy with the arriving electromagnetic waves, a and b are the primary and secondary coils of a transformer, and, the circuit C_1a being syntonized with the antenna, oscillations are set up which induce oscillations in the coherer, the drop in whose resistance enables the cell B to produce sufficient current to attract the armature of the relay R, and actuate the Morse recorder M. Owing to the presence of the condenser C_2 , which bisects the secondary coil of the transformer, there is no appreciable steady current in the battery and relay circuit, except when the coherer S has its low resistance due to the arrival of the electromagnetic waves.

Other methods have also been employed for the detection of electromagnetic radiations, amongst which we should note the employment of the heating effect in a fine wire, of the oscillatory current, the effect upon the hysteresis in iron and steel, and the oscillation valve. We will consider a few typical forms of these applications.

Thermal Detector.—A very sensitive thermal method was employed by C. Tissot,¹ in which the apparatus took the form of a bolometer.

Two resistances of very fine platinum wire, P and Q, constructed by drawing down a silver wire having a platinum core, and afterwards dissolving away the silver, are placed in the arms of a Wheatstone bridge (Fig. 381), and a balance for steady current obtained. When the oscillatory current passes through P, the rise in temperature produced by the heating effect of the current increases the resistance and destroys the balance, and a galvanometer deflection will be observed. In order to increase the sensitiveness and avoid thermal disturbances, the platinum wires, which are arranged in a lozenge-shaped form, are sealed in vacuum vessels.

The Duddell thermal galvanometer (p. 80) and the Fleming thermal microammeter (p. 222) have also been used for detecting and measuring these small oscillatory currents.

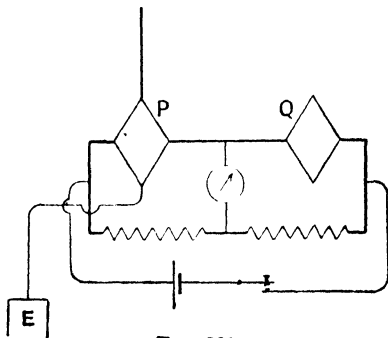

FIG. 381.

¹ C. Tissot, *Journ. d. Phys.*, vol. 3, 1904.

The Fleming Oscillation Valve (see p. 494) has also been used for detecting radiations. When the filament of the incandescent lamp (Fig. 382) is glowing, a current will only pass in the galvanometer circuit in such a direction, that a negative charge flows from the filament to the plate P. Hence when the oscillatory current is brought in by the terminals A and B, it is unilateral in the galvanometer circuit, one half of each oscillation being quenched by the lamp.

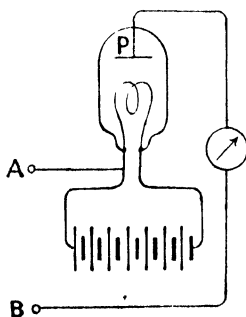

FIG. 382.

A galvanometer deflection is then produced by the oscillations. The galvanometer may be replaced by a telephone, in which case each train of oscillations produces a sound in the telephone. Marconi has modified the arrangement by placing the telephone in series with the secondary circuit of a transformer, the primary of which is in the valve circuit. For the three-electrode valve see p. 493.

Crystal Detector.—A similar rectifying valve is found in the case of certain crystals such as zincite, silicon, galena, etc., the most useful of which for general purposes is carborundum, consisting of silicon and carbon. The crystal is fixed in a metal mount, and

one of the sharp angles of the crystal bears against a metal plane. The conductivity of the contact depends upon the direction of the current. The asymmetry is, however, greatest when there is a p.d. of about 1 volt between the metal and the crystal, the crystal being at the lower potential. This contact p.d. is maintained by a separate cell, and is adjusted to greatest sensitiveness by a potentiometer form of resistance. In this way the rectification of the oscillatory current at the receiving station is effected.

One great advantage in the last three methods of detecting electrical waves, lies in the fact that immediately the oscillations cease, the detector returns automatically to its previous condition. It is therefore always ready to receive the waves, and in this respect differs from the coherer, which requires tapping to make it "de-cohere" before it is again sensitive.

Magnetic Detectors have been devised, in which the property of the oscillations of demagnetising a specimen of iron or steel is made use of. The first of such detectors is that of Prof. Rutherford (p. 446), which he employed in measuring the damping of the oscillations. It has been shown by C. Tissot¹ and C. Maurain² that when the specimen is in the form of steel wire which is thin enough for the magnetic oscillations to penetrate to the interior, their effect is to destroy the magnetic hysteresis in the specimen. Their effect is thus similar to

¹ C. Tissot, *Comptes Rendus*, 136, p. 361. 1903.

² C. Maurain, *Comptes Rendus*, 137, p. 914. 1903.

a mechanical disturbance. A number of detectors in which this effect is used have been devised, that of Marconi,¹ which has been used as a receiver on long distance wireless telegraphic systems, being illustrated diagrammatically in Fig. 383. The belt *aa*, which consists of a bundle of thin silk-covered iron wires, passes over the pulleys *e, e*, which are in continuous slow rotation, and as the iron passes near the poles of the permanent horseshoe magnets *d, d*, it is strongly magnetised. As the iron wire moves forward, part of the magnetism is retained owing to the hysteresis of the magnetism in the material, and the distribution of magnetisation is unsymmetrical with respect to the plane of symmetry of the permanent magnets, the part of *aa* which has passed being magnetised, while that part which is arriving is still unmagnetised. As the electrical oscillations from the aerial *A* pass through the solenoid *gb*, which surrounds the moving wire, they destroy the hysteresis effect, and the magnetisation of the wire will, during the time that the oscillations last, be symmetrically situated with respect to the permanent magnets. The oscillations therefore cause a redistribution of the magnetisation of the wire, and thus the magnetic induction through the second coil *c* varies. A click will be heard in the telephone *T* at the instant of starting of the oscillations, and if the trains of oscillations corresponding to each discharge at the transmitting station succeed each other rapidly, a continuous hum will be heard in the telephone. A hum of long or short duration corresponds to a dash or dot of the Morse system.

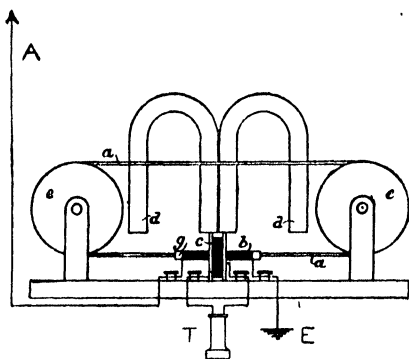

FIG. 383.

From Fleming's "Principles of Electric Wave Telegraphy."

Open and Closed Oscillators.—The oscillator of the Hertz type, or that used by Marconi, is said to be of the "open" type, and in this case the amount of energy radiated at each oscillation is considerable. Only a few oscillations occur before the amplitude is reduced to such an extent that the maximum potential difference is insufficient to break down the air resistance of the gap, and the oscillations then cease. The damping is therefore considerable, being chiefly due to the radiation of energy, and is only slightly affected by the resistance of the gap.

On the other hand, the Leyden jar, having nearly closed circuit (p. 438), or an oscillator of the type shown in Fig. 384 is known as a

¹ G. Marconi, *Proc. Roy. Soc. Lond.*, 70, p. 341. 1902.

closed oscillator. In this case the amount of radiation is very small, the Faraday tubes being chiefly situated between the plates of the condenser, and the magnetic field during the period of maximum current being in the form of closed curves linked with the conductor.

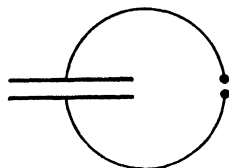

FIG. 384.

The decrement of the oscillation is in this case small, and is chiefly due to the resistance of the circuit including the air gap, very little energy being lost by radiation. With an open oscillator of the Hertz type, the amplitude may be reduced to 1 per cent. of its initial value after about 5 or 10 oscillations, while for a closed resonator as many as 30 or 40 oscillations may occur for the same reduction.

In the case of radiation from a Marconi antenna, the length of wave may be, say, 100 metres, or 10^4 cms. Taking the velocity of such a wave as 3×10^{10} cms. per second, we see that the frequency given by $v = n\lambda$, is 3×10^6 oscillations per second. If only three such waves are emitted before the amplitude falls below that required for effective signalling, the time of effective emission is only 10^{-6} seconds. The induction coil producing the spark, will probably not produce more than 100 sparks per second, so that, if the interval between successive sparks is $\frac{1}{100}$ second, all this time (except the 10^{-6} second occupied by effective radiation) is wasted. Owing to these long intervals, during which no radiation is occurring, the rate at which energy can be transmitted is small, and many attempts have been made to produce by some means a continuous train of waves.

Duddell Singing Arc.—It was found by W. Duddell¹ that oscillations occur when a shunt circuit having inductance and capacity is placed across the electric arc between solid carbons; cored carbons are useless. The arc must be maintained by current from some steady source of supply, such as a secondary battery, a resistance R

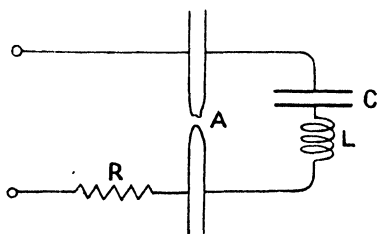

FIG. 385.

(Fig. 385), being in series. Then oscillations of the frequency

$$\frac{1}{2\pi\sqrt{LC}}$$

occur in the circuit ALC , and this alternating current being superimposed upon the continuous current in the arc, the variation in intensity and in the rate of

evolution of heat causes the sound-waves of definite pitch to be emitted.

To understand this production of oscillations, let us consider what will happen on closing the shunt circuit ACL . The flow of current

¹ W. Duddell, *Journ. Inst. El. Eng.*, 30, p. 232. 1900.

into the condenser causes a drop in that in the arc, with consequent drop in temperature and increase in resistance. The resistance of the arc is then a greater fraction of the resistance of the main circuit, and the difference of potential between the carbons rises, with further production of flow into the condenser. Eventually the accumulation of charge in the condenser raises the difference of potential between its coats to that between the carbons, and the current into the condenser ceases, and the arc will regain its original condition. The current in the arc having risen again to its original value, its resistance has fallen, and likewise the fall of potential across it, so that a reverse flow from the condenser begins, and a reverse set of changes will follow. The inductance in the shunt circuit has the function of giving it inertia, so that, the current having started, the circuit is always carried past the stable condition, and oscillations occur. The existence of the oscillation depends upon the fact that the resistance of the arc varies with the current in such a manner that the potential difference between the carbons diminishes with increasing current, and the arc behaves as though it had a negative resistance. This is the condition for the production of the singing arc.

Poulsen Arc.—The frequency of oscillation with the Duddell arrangement is not very great, but V. Poulsen¹ has shown that with the arc in hydrogen, or any hydrocarbon vapour, and a strong magnetic field at right angles to the arc, oscillations of considerable intensity and with frequency of over a million per second can be maintained. The negative electrode (A) is carbon, and the positive is copper and is water cooled (B) (Fig. 386).

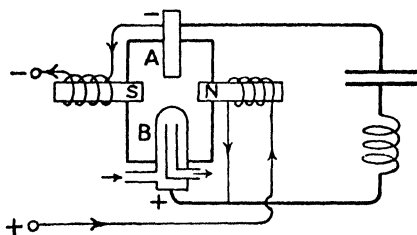

FIG. 386.

Wehnelt Electrolytic Interrupter.²—In addition to the last two methods of increasing the number of oscillations produced per second, the mode of interruption of the induction coil itself has been improved. One such improvement is the Wehnelt electrolytic interrupter. A large lead plate which serves as cathode dips into a fairly large vessel of dilute sulphuric acid (one of acid to seven or eight parts of water), the anode being a platinum wire of which only the tip is in contact with the solution. On placing such an electrolytic cell in a circuit in which there is an electromotive force of over 40 volts, an intermittent current will flow, provided that the circuit contains a fairly large inductance. The frequency of the interruptions is a complicated

¹ V. Poulsen, Internat. Elect. Congress, Trans. 2, 1905.

² A. Wehnelt, *Elektrotechn. Zeitschr.*, 20, p. 76. 1899.

function of the inductance, the voltage, and the form of the platinum tip. In Fig. 387 a platinum wire of about a millimetre diameter projects from a porcelain sheath, the amount of wire exposed to the solution being adjustable by means of the screw.

When the cell is used as interrupter for the induction coil, it replaces the usual make-and-break and the condenser. The frequency of interruption may reach several thousand per second with an E.M.F. of 50 to 100 volts, and the secondary discharge is then of the form of a brilliant flame. For voltages below about 20 or above about 120 the current ceases to be intermittent.

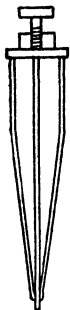

FIG. 387. break is contained in a vessel, usually filled with coal gas.

The advantage of this form of break is that high frequency may be attained, and the duration of the primary current may be varied by altering the manner in which the mercury jet impinges against the rotating sectors.

Measurement of Damping.—Many methods for determining the decrement of the oscillations have been devised, since it is important for practical purposes to know how many oscillations occur at each discharge. A method due to Prof. Rutherford¹ is of special interest. If a piece of iron, magnetised to saturation, be placed within a loop of the circuit in which the oscillations are occurring, the first half-oscillation, if in the direction tending to increase the magnetisation of the iron, will produce no effect, the iron being already saturated. The second half-oscillation, however, will partially demagnetise the iron, and the third will partially remove the effect of the second, and so on. If $I_1, I_2, I_3,$ etc., are the magnetising effects of the successive half-oscillations, the resulting demagnetisation will be proportional to $I_2 - I_3 + I_4 \dots$. On the other hand, if the first half-oscillation is in such a direction that it tends to demagnetise the iron, the resulting demagnetisation is proportional to $I_1 - I_2 + I_3 - I_4 + \dots$.

Prof. Rutherford employed a circular arc of wire to produce the demagnetisation, the arc being included in the oscillatory circuit, and being varied in length in the two cases, until the magnetisation remaining in the iron as tested by a magnetometer is the same for either direction of the first half-oscillation.

If $I_1, I_2, I_3,$ etc., form a geometric series, that is, if the oscillations die away logarithmically—

¹ E. Rutherford, *Phil. Trans.*, 189, A, p. 1. 1897.

$$I_1 - I_2 + I_3 - \dots = \frac{I_1 n}{1 + \frac{I_2}{I_1}}$$

and,

$$I_2 - I_3 + I_4 - \dots = \frac{I_2 n}{1 + \frac{I_3}{I_2}}$$

If l_1 and l_2 be the lengths of arc which make these two demagnetising effects equal—

$$l_1 I_1 = l_2 I_2,$$

and since l_1 and l_2 can be obtained by trial and then measured, the ratio $\frac{I_2}{I_1}$ or the decrement may be found. The logarithmic decrement is then $\log_e \frac{l_1}{l_2}$.

In this way Prof. Rutherford found that the damping depends upon the magnetic properties of the circuit, being great when iron wire is employed, a result which would be expected, since the hysteresis loss at each cycle means a loss of energy. Also the damping depends upon the capacity and the length of gap. With a frequency of 1.25×10^6 per second, it was found for a particular circuit that for spark gap 0.12 cm., $\frac{I_2}{I_1} = 0.97$, and the resistance of the gap is 0.7 ohm. With length of gap 0.61 cm., $\frac{I_2}{I_1} = 0.70$, and resistance of gap is 12.0 ohms. The increase in length of gap evidently causes a large increase in the decrement.

The method employed by V. Bjercknes¹ to determine the damping, was to measure the root mean square value of the difference of potential between the knobs, by means of an electrostatic voltmeter, for the whole train of waves, the potential difference at the beginning of the oscillation being known from the length of the spark gap.

We have seen that for a circuit having resistance, inductance, and capacity, the oscillatory discharge is of the type—

$$q = Q_0 \epsilon^{-bt} \cos pt \quad (\text{p. 338}),$$

where,

$$p = \sqrt{\frac{1}{LC} - 4L^2}$$

and the potential difference between the knobs at any instant is therefore—

$$v = V_0 \epsilon^{-bt} \cos pt.$$

The voltmeter reading is proportional to the mean square value of the

¹ V. Bjercknes, *Wied. Ann. d. Phys.*, **44**, p. 74. 1891.

potential difference, and at each discharge it receives an impulse proportional to $\int_0^\infty v^2 dt$. The upper limit of the integral is taken as infinity, since the oscillations accompanying any discharge are completely damped out long before the next discharge takes place.

$$\begin{aligned} \text{Now,} \quad \int_0^\infty v^2 dt &= V_0^2 \int_0^\infty \epsilon^{-2bt} \cos^2 pt \, dt \\ &= V_0^2 \int_0^\infty \epsilon^{-2bt} \frac{1 + \cos 2pt}{2} dt \\ &= V_0^2 \left[-\frac{\epsilon^{-2bt}}{4b} \right]_0^\infty + \frac{V_0^2}{2} \int_0^\infty \epsilon^{-2bt} \cos 2pt \, dt \\ &= \frac{V_0^2}{4b} - \frac{V_0^2 b}{2(p^2 + b^2)}. \end{aligned}$$

Since b is of the order of 10^5 , and p of the order 4×10^3 , no sensible error will be introduced by omitting the second term; and we see that each impulse given to the needle is $\frac{V_0^2}{4b}$. If there are n discharges per second, the couple acting on the needle is proportional to $\frac{nV_0^2}{4b}$; If the deflection is θ , and the electrometer be calibrated by a steady voltage V_1 giving a deflection θ_1 —

$$\begin{aligned} \frac{\theta}{\theta_1} &= \frac{nV_0^2}{4b} \cdot \frac{1}{V_1^2} \\ \therefore b &= \frac{nV_0^2 \theta_1}{4\theta V_1^2}. \end{aligned}$$

In the experiment, oscillations in the secondary circuit S (Fig. 388)

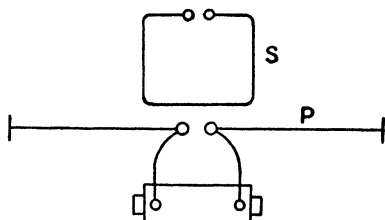

FIG. 388.

were excited by those in the primary P, the latter being an open oscillator and the former one of the closed type. Also V_1 was 20 volts, giving a deflection θ_1 of 19 scale divisions, and $n = 42$.

Thus—

$$b = \frac{19 \times 42}{4 \times 20^2} \cdot \frac{V_0^2}{\theta} = 0.5 \frac{V_0^2}{\theta}.$$

For the circuit S, $\theta = 30$ scale divisions when the length of spark gap was 0.3 mm., which from Paschen's results¹ indicated a value of 2080 volts for V_0 .

¹ F. Paschen, *Wied. Ann.*, 37, p. 69. 1889.

Hence $b = \frac{0.5 \times 2080^2}{30} = 70,000$ approx., which means that in one second the amplitude diminishes in the ratio 1 to ϵ^{-70000} .

The wave-length was 443 cms. and hence the number of half-vibrations occurring in one second is $\frac{2 \times 3 \times 10^{10}}{443} = \frac{6 \times 10^{10}}{443}$, and the interval from the start to the end of the first half-oscillation is $\frac{443}{6 \times 10^{10}}$, and the amplitude in one half-vibration diminishes in the ratio—

$$1 \text{ to } \epsilon^{-\frac{70000 \times 443}{6 \times 10^{10}}},$$

that is 1 to $\epsilon^{-0.0005}$.

$$\therefore \text{decrement} = \frac{1}{\epsilon^{-0.0005}} = \epsilon^{0.0005} = 1.0005$$

and logarithmic decrement = 0.0005.

Hence in 1000 oscillations the amplitude is reduced from 1 to $\frac{1}{(1.0005)^{2000}} = 0.37$; that is, to about one-third of its original value.

In the case of the primary P, the damping was more than 100 times as great, which would be expected from the fact that it is an open oscillator.

Propagation of Waves in Wires and Cables.—The inductance and capacity of a single wire, although very small, become of importance when the currents in it vary with great rapidity, as, for example, when high frequency oscillatory currents are flowing in them, or when they are carrying fairly rapidly alternating currents, as in the case of those used in telephony.

If L be the inductance per unit length of the cable, and R its resistance, then Ldx and Rdx are the inductance and resistance of length dx , and if I be the current flowing in it, the equation on p. 303 for the electromotive forces over the short length dx becomes—

$$L \frac{dI}{dt} dx + R I dx = dE,$$

or,
$$L \frac{dI}{dt} + R I = \frac{dE}{dx} \quad (i)$$

The current flowing into the section dx may not be equal to that flowing out of it, for two reasons: first, the capacity Cdx will take a charge $Cdx \cdot \frac{dE}{dt} \cdot dt$ in the time dt , $\frac{dE}{dt}$ being the rate of increase of potential at any point; and in the second place the charge $K E dx dt$ will leak out from the conductor, when K is the conductance of the insulation per unit length of the conductor. Again, $I dt$ is the charge

entering the section of length dx through one end in time dt , and $(I + \frac{dI}{dx} dx)dt$ that leaving by the other end.

$$\text{Hence, } C \frac{dE}{dt} \cdot dx \cdot dt + KE \cdot dx \cdot dt = (I + \frac{dI}{dx} dx)dt - Idt$$

$$\therefore C \frac{dE}{dt} + KE = \frac{dI}{dx} \dots \dots \dots \text{(ii)}$$

This and equation (i) determine the current and potential and their variations at all points of the cable.

The case of most importance is that in which a harmonic electromotive force $E = E_0 \cos pt$ is applied at a point in the cable, say at one end. If the cable be infinite in length, the electromotive force and current at any point of it will after a time execute simple harmonic changes, the time, in the cases that we shall consider, being extremely short; but the amplitude of the oscillation may vary from point to point along the cable. We shall only make one assumption, and that is, that the electromotive force and current vary harmonically at each point.

Then E is the real part, or projection upon the axis of x , of the rotating vector $E_0 e^{jpt}$, and I that of $I_0 e^{jpt}$, where E_0 and I_0 are the values of the rotating vectors for each point (see p. 377).

Equations (i) and (ii) may then be replaced by

$$1. \frac{d}{dx}(I_0 e^{jpt}) + RI_0 e^{jpt} = \frac{d}{dx}(E_0 e^{jpt}),$$

and,
$$C \frac{d}{dt}(E_0 e^{jpt}) + KE_0 e^{jpt} = \frac{d}{dx}(I_0 e^{jpt}),$$

which may be written,

$$\frac{d}{dx}(E_0 e^{jpt}) = (jLp + R)I_0 e^{jpt} \dots \dots \dots \text{(iii)}$$

and,
$$\frac{d}{dx}(I_0 e^{jpt}) = (jCp + K)E_0 e^{jpt} \dots \dots \dots \text{(iv)}$$

Differentiating the first of these with respect to x , and substituting from the second, we get—

$$\frac{d^2}{dx^2}(E_0 e^{jpt}) = (jLp + R) \frac{d}{dx}(I_0 e^{jpt})$$

$$= (jLp + R)(jCp + K)E_0 e^{jpt},$$

or,
$$\frac{d^2}{dx^2}(E_0 e^{jpt}) = P^2 E_0 e^{jpt},$$

where,
$$P^2 = (jLp + R)(jCp + K).$$

Similarly, reversing the order of operation, we get—

$$\frac{d^2}{dx^2} (I_0 e^{jpt}) = P^2 I_0 e^{jpt}.$$

Calling the quantity $E_0 e^{jpt}$, which is a rotating vector whose length is constant for any point of the wire, ρ , we see that the equation

$$\frac{d^2 \rho}{dx^2} = P^2 \rho$$

is a homogeneous equation, and as on p. 22, we obtain the solution in the form $\rho = \epsilon^{ax}$.

Then,
$$\frac{d^2 \rho}{dx^2} = \alpha^2 \epsilon^{ax},$$

$$\therefore \alpha^2 \epsilon^{ax} = P^2 \epsilon^{ax},$$

and,

$$a = \pm P.$$

The most general form of the solution is therefore

$$\rho = A \epsilon^{Px} + B \epsilon^{-Px},$$

that is,

$$E_0 e^{jpt} = A \epsilon^{Px} + B \epsilon^{-Px},$$

and similarly,

$$I_0 e^{jpt} = A_1 \epsilon^{Px} + B_1 \epsilon^{-Px}.$$

In order to find the four constants A , B , A_1 , and B_1 , let us consider that at the near end of the cable $E_0 = \bar{E}$, $I_0 = \bar{I}$.

Then, since at this point $x = 0$,

$$\bar{E} e^{jpt} = A + B,$$

$$\bar{I} e^{jpt} = A_1 + B_1.$$

Again, at an infinite distance along the cable, let the disturbance have diminished so much in amplitude that $E_0 = 0$, and $I_0 = 0$. For this to be true we must have $A = 0$, and $A_1 = 0$; otherwise the terms $A \epsilon^{Px}$ and $A_1 \epsilon^{Px}$ would be infinite.

$$\therefore B = \bar{E} e^{jpt}, \text{ and, } B_1 = \bar{I} e^{jpt}$$

and,

$$E_0 e^{jpt} = \bar{E} \epsilon^{-Px} e^{jpt},$$

$$I_0 e^{jpt} = \bar{I} \epsilon^{-Px} e^{jpt}.$$

or,

$$E_0 = \bar{E} \epsilon^{-Px}$$

$$I_0 = \bar{I} \epsilon^{-Px}$$

The quantity P , or $\sqrt{(jLp + R)(jCp + K)}$, is itself complex, and may be written in the form $a + jb$.

Whence, $E_0 e^{jpt} = \bar{E}_0 e^{-(a+jb)x} e^{jpt}$,
 $I_0 e^{jpt} = \bar{I}_0 e^{-(a+jb)x} e^{jpt}$,
 or, $E_0 e^{jpt} = \bar{E}_0 e^{-ax} e^{j(pt-bx)} \dots \dots \dots$ (v)
 $I_0 e^{jpt} = \bar{I}_0 e^{-ax} e^{j(pt-bx)} \dots \dots \dots$ (vi)

Now, E and I are the real parts of $E_0 e^{jpt}$ and $I_0 e^{jpt}$, or their projections upon the axis of x. They are therefore given by the equations

$E = \bar{E}_0 e^{-ax} \cos (pt - bx) \dots \dots \dots$ (vii)

and, $I = \bar{I}_0 e^{-ax} \cos (pt - bx) \dots \dots \dots$ (viii)

We therefore see that their amplitudes at any point are $\bar{E}_0 e^{-ax}$ and $\bar{I}_0 e^{-ax}$, and their phases are bx behind those at the origin. Hence, points for which x differs by the amount $\frac{2\pi}{b}$ are in the same phase at the same time, and $\frac{2\pi}{b}$ may be looked upon as the wave-length of the disturbance.

Further, we see that the amplitude $\bar{E}_0 e^{-ax}$ diminishes exponentially as we pass away from the origin.

Again, the wave-length being $\frac{2\pi}{b}$, and the frequency n, $\frac{p}{2\pi}$ (p. 349),

velocity = wave-length \times frequency
 $= \frac{p}{b}$.

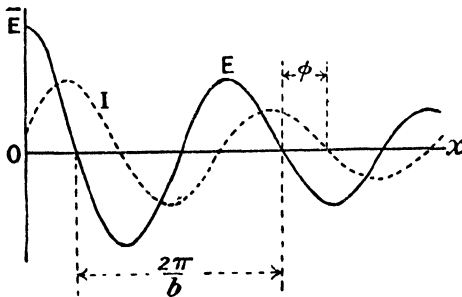

FIG. 389.

The values of E are drawn in Fig. 389, for the instant at which that at the origin is \bar{E} . As each point goes through a harmonic change in the value of E, the points of zero value will now travel to the right

with velocity $\frac{v}{b}$. This is the rate at which any given phase of the disturbance travels along the cable.

The relation between \bar{I} and \bar{E} may be obtained from equation

$$E_0 e^{pt} = \bar{E} e^{-lx} e^{pt},$$

for,
$$\frac{d}{dx}(E_0 e^{pt}) = -P \bar{E} e^{-lx} e^{pt}.$$

But from equation (iii)—

$$\frac{d}{dx}(E_0 e^{pt}) = (jI_p + R) I_0 e^{pt},$$

$$\therefore I_0 = -\frac{P}{jI_p + R} \bar{E} e^{-lx},$$

or,

$$I_0 = -\frac{P}{jI_p + R} E_0,$$

and since,

$$P = \sqrt{(jI_p + R)(jC_p + K)},$$

$$I_0 = -\frac{\sqrt{jC_p + K}}{\sqrt{jI_p + R}} E_0$$

Now,
$$jC_p + K = \sqrt{C^2 p^2 + K^2} e^{j\theta_1} \quad (\text{see p. 377})$$

where,

$$\tan \theta_1 = \frac{Cp}{K},$$

and,

$$jI_p + R = \sqrt{L^2 p^2 + R^2} e^{j\theta_2},$$

where,

$$\tan \theta_2 = \frac{I_p}{R},$$

$$\therefore \frac{jC_p + K}{jI_p + R} = \left(\frac{C^2 p^2 + K^2}{L^2 p^2 + R^2} \right)^{\frac{1}{2}} e^{j(\theta_1 - \theta_2)},$$

and,

$$I_0 = -E_0 \left(\frac{C^2 p^2 + K^2}{L^2 p^2 + R^2} \right)^{\frac{1}{2}} e^{j\theta_1 - \theta_2},$$

The current amplitude is therefore everywhere $E_0 \left(\frac{C^2 p^2 + K^2}{L^2 p^2 + R^2} \right)^{\frac{1}{2}}$, and it is retarded in phase behind the electromotive force by an amount $\pi - \frac{\theta_1 - \theta_2}{2}$, the quantity π being introduced on account of the negative sign before the expression, since this indicates a reversal of phase, or retardation of the phase by π .

The dotted curve in Fig. 389 indicates the current at every point of the cable. Its equation is—

$$I = E \left(\frac{C^2 p^2 + K^2}{L^2 p^2 + R^2} \right)^{\frac{1}{2}} e^{-ax} \cos (pt - bx - \phi).$$

The quantity a is called the attenuation factor, since it determines the rate of decay of the amplitude of the oscillation as we pass along the cable; while b is called the wave-length factor, since $\frac{2\pi}{b}$ is the distance between points at which the phase at any instant is the same.

To determine a and b in terms of the constants of the conductor, we must remember that

$$P = \sqrt{jLp + R} \sqrt{jCp + K} = a + jb.$$

Squaring and multiplying out, we have—

$$-LCp^2 + KR + j(KLp + RCp) = a^2 - b^2 + 2jab,$$

and,

$$\begin{aligned} \therefore a^2 - b^2 &= KR - LCp^2, \\ 2ab &= p(KL + RC) \quad (\text{see p. 376}). \end{aligned}$$

Substituting in the first, the value of b found from the second, we have—

$$a^2 - \frac{p^2(KL + RC)^2}{4a^2} = KR - LCp^2,$$

a quadratic in a^2 , the roots of which are given by

$$2a^2 = \pm \sqrt{(L^2p^2 + R^2)(C^2p^2 + K^2)} + (KR - CLp^2).$$

Since a^2 must be positive, a being a real quantity, the positive sign is taken. Similarly we may solve for b .

Then—

$$2a^2 = \sqrt{(L^2p^2 + R^2)(C^2p^2 + K^2)} + (KR - LCp^2) \quad \dots \quad (\text{ix})$$

$$2b^2 = \sqrt{(L^2p^2 + R^2)(C^2p^2 + K^2)} - (KR - LCp^2) \quad \dots \quad (\text{x})$$

The problem of the propagation of electrical currents in cables was first solved by Lord Kelvin,¹ but the inductance and leakage were there left out of account. The matter was rectified by Oliver Heaviside, who obtained the equations (i) and (ii).

When L and K are omitted,

$$2a^2 = RCp = 2b^2,$$

$$\therefore \text{from (vii) and (viii), } E = E_0 \epsilon^{-\sqrt{\frac{RCp}{2}}x} \cos \left(pt - \sqrt{\frac{RCp}{2}}x \right),$$

$$\text{and, } I = \frac{EI_0}{R} \epsilon^{-\sqrt{\frac{RCp}{2}}x} \cos \left(pt - \sqrt{\frac{RCp}{2}}x \right).$$

The velocity of propagation is in this case $\sqrt{\frac{2p}{RC}}$, and the attenuation constant $\sqrt{\frac{RCp}{2}}$.

¹ Sir W. Thomson, *Mathematical and Physical Papers*, vol. 2.

Telephone Circuits.—The frequencies of oscillation used in telephony are limited by the range of the human voice. Thus several hundred per second is the order of frequency of most importance. If, in transmitting a complex wave such as that produced by the human voice, the simple waves into which it may be resolved are not all transmitted with the same attenuation, the quality of the wave received at the end of the cable will differ from that transmitted. Since the attenuation depends upon the frequency, the distortion produced may have a more disturbing effect than the actual dying away with distance of the amplitude of the wave.

In the case of submarine and underground cables, where the conducting wire is surrounded by a conducting sheet, and separated from it by some insulating material, the capacity is relatively great and the inductance small.

$$\text{Then,} \quad 2a^2 = R\sqrt{C^2p^2 + K^2} + (KR - LCp^2).$$

In this case it is an advantage to increase K , the leakage from the cable, for this will make the attenuation constant less dependent upon the frequency $\frac{p}{2\pi}$. A reduction in R will in all cases reduce the attenuation factor. Hence the advantage of making the cables to have as low a resistance as possible. We may consider the attenuation to be the result of the loss in energy of the wave on account of the ohmic resistance of the conductor in which the current is flowing, and hence the advantage of low-resistance cables.

It has been suggested by O. Heaviside that a distortionless cable might be constructed by increasing to a suitable extent the amount of leakage.

Amongst other suggestions we find that of making $\frac{R}{L} = \frac{K}{C}$, in which case equation (ix) becomes

$$a^2 = \frac{CR^2}{L} = \frac{LK^2}{C} = KR,$$

and (x) becomes

$$2b^2 = LC \cdot 2p^2,$$

and,

$$b = p\sqrt{LC}.$$

In this case the attenuation factor is constant, and the velocity $\frac{p}{b}$ is $\frac{1}{\sqrt{LC}}$. The waves in this case are transmitted without distortion.

In cables, R and C are the most important terms, and it is therefore necessary to increase L and K . The latter is easy, for it is only necessary to diminish the insulation. To increase L , the method of adding inductances at intervals by introducing a number of turns surrounding an iron core is commonly adopted, and E. Soleri¹ and

¹ E. Soleri, *Atti dell' Assoc. Elett. Ital.*, 12, p. 181. 1903.

M. Miniotti¹ have suggested the use of a strand of iron wire in the cable, the high permeability of which produces the desired increase in inductance.

High Frequency Circuits.—When the frequency of oscillation in a circuit is of the order occurring in the case of Hertz's oscillators, the quantities L^2p^2 and C^2p^2 are so great in comparison with R^2 and K^2 , that the latter may be neglected. The equations to the waves of potential and current are then very much simplified, for equations (ix.) and (x.) become

$$\begin{aligned} 2a^2 &= KR \\ \text{and} \quad 2b^2 &= 2LCp^2 \end{aligned}$$

since in the equation for b , KR may be neglected in comparison with $2LCp^2$. Then from (vii) and (viii),

$$E = \bar{E}\epsilon^{-\sqrt{\frac{KR}{2}}x} \cos(pt - \sqrt{LC}p^2x),$$

$$\text{and,} \quad I = \bar{I}\epsilon^{-\sqrt{\frac{KR}{2}}x} \cos(pt - \sqrt{LC}p^2x).$$

from which we see that the velocity of propagation is now $\frac{1}{\sqrt{LC}}$, that is, it is the inverse of the oscillation constant (\sqrt{LC}) of the cable.

Steady Oscillation in Wires—In a comparatively small length of wire, such as the antenna used in wireless telegraphy, the effect of attenuation is very small, and the last equations may without sensible error be written—

$$\begin{aligned} E &= \bar{E} \cos(pt - \sqrt{LC}p^2x) \\ \text{and,} \quad I &= \bar{I} \cos(pt - \sqrt{LC}p^2x). \end{aligned}$$

And from p. 453 we see that I lags behind E by an angle

$$\phi = \pi - \frac{\theta_1 - \theta_2}{2}.$$

When Lp is very great in comparison with R , and Cp in comparison with K , which will be the case for very rapid oscillations, $\theta_1 = 90^\circ$ and $\theta_2 = 90^\circ$, and in the limit $\phi = 180^\circ$. And further, $\left(\frac{C^2p^2 + K^2}{L^2p^2 + R^2}\right)^{\frac{1}{2}}$

becomes $\sqrt{\frac{C}{L}}$,

$$\therefore I = \bar{E}\sqrt{\frac{C}{L}} \cos(pt - \sqrt{LC}p^2x - 180^\circ).$$

By a process of reasoning very similar to that on p. 431, we may show that on reaching the end of the wire reflection occurs; but the reflection may occur under two different conditions. If the wire ends

¹ M. Miniotti, *Atti dell' Assoc. Elett. Ital.*, 12, p. 193. 1908.

in a massive conductor, or is earthed, the electrical intensity, in this case E , is reduced to zero at this point, with production of a reversed wave travelling back along the wire, the equation of which is

$$E = -\bar{E} \cos (pt + \sqrt{LCp^2}x).$$

On the other hand, if the end of the wire is insulated, the current is here reduced to zero, and the reversed current wave is

$$I = -\bar{E} \sqrt{\frac{C}{L}} \cos (pt + \sqrt{LCp^2}x - 180^\circ).$$

In the first case the end of the wire is a node with respect to E , and in the second a node with respect to I . In either case the corresponding equation for I or E may be found.

The problem of the mode of electrical vibration in a wire is very similar to that of a sound-wave in an open or closed pipe. The reflected wave $I = -\bar{E} \sqrt{\frac{C}{L}} \cos (pt + \sqrt{LCp^2}x - 180^\circ)$ and the direct wave $I = \bar{E} \sqrt{\frac{C}{L}} \cos (pt - \sqrt{LCp^2}x - 180^\circ)$ combine to produce the vibration

$$\begin{aligned} I_1 &= \bar{E} \sqrt{\frac{C}{L}} \{ \cos (pt - 180^\circ - \sqrt{LCp^2}x) - \cos (pt - 180^\circ + \sqrt{LCp^2}x) \} \\ &= 2\bar{E} \sqrt{\frac{C}{L}} \sin \sqrt{LCp^2}x \sin (pt - 180^\circ). \end{aligned}$$

This is a steady vibration of the type $I' \sin (pt - 180^\circ)$, where $I' = 2\bar{E} \sqrt{\frac{C}{L}} \sin \sqrt{LCp^2}x$, and all points are in the same phase at the same time. The wave-length of the disturbance is $\frac{2\pi}{\sqrt{LCp^2}}$, and when the length of the wire is a quarter of this, the reflected wave on arriving at the starting point has traversed half a wave-length, and is in phase with the wave then starting. The state of affairs is similar to that in a closed organ pipe sounding its fundamental. For a steady vibration the length of the wire must be

$$\frac{\pi}{2\sqrt{LCp^2}}, \frac{3\pi}{2\sqrt{LCp^2}}, \frac{5\pi}{2\sqrt{LCp^2}}$$

that is, a quarter, three quarters, five quarters, etc., of the wave-length of the disturbance. Remembering that the free end of the wire must

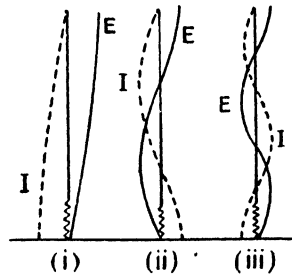

FIG. 390.

be a point of maximum variation of potential and the earthed end a node, we see that three of the possible modes of oscillation in an antenna or Marconi aerial are indicated in Fig. 390, the amplitude of the current at each point by the dotted line, and that of the potential by the full line, but their relative phases are not indicated.

Professor J. A. Fleming,¹ using a helix instead of a straight wire, in which case the capacity and inductance per unit length of the helix determine the velocity of propagation, has found the position of the nodes and antinodes for a series of oscillations, including the fundamental and the first five harmonics. The wave-lengths are therefore $4l$, $\frac{4}{3}l$, $\frac{4}{5}l$, $\frac{4}{7}l$, $\frac{4}{9}l$, and $\frac{4}{11}l$, where l is the length of the solenoid. The oscillations were produced in a closed oscillatory circuit consisting of two condensers and a variable inductance L (Fig. 391).

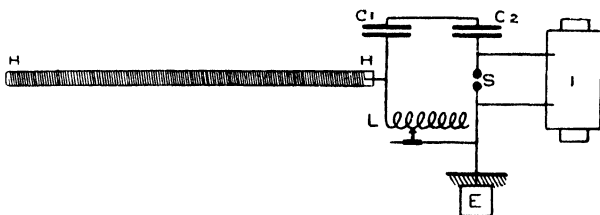

FIG. 391.

(From Fleming's "Principles of Electric Wave Telegraphy.")

One end of the helix is joined at the point H to the oscillatory circuit. To detect the nodes, a narrow tube containing the gas neon at low pressure is placed over the helix, the direction of the tube being at right angles to the axis of the helix. The neon tube is not luminous over a node of potential, but at other points it glows with a bright red-orange luminosity. It was found that the nodes are not quite equally spaced along the helix, being a little further apart near the oscillator than near the free end of the helix.

Lecher's Wires.—The method of employing the steady oscillations set up in a wire to find the velocity of propagation was first used by Sir Oliver Lodge (p. 434), who succeeded in showing that the velocity of propagation of the wave is equal to that of light. This method was also used by Hertz and afterwards modified by Sarasin and de la Rive, while E. Lecher² gave it the form shown in Fig. 392.

One coat of the condenser C_1 is connected to the wire AX, and one coat of the C_2 to BY, the remaining coats being connected to the spark balls and to the induction coil. The variations of potential at C_1 start waves which travel down AX, and those at C_2 start similar

¹ J. A. Fleming, *Phil. Mag.*, 8, p. 417. 1904.

² E. Lecher, *Wied. Ann.*, 41, p. 850. 1890.

waves in opposite phase down BY. It should be noted that in this case the wires are electrostatically coupled to the oscillator, in distinction to the magnetic or transformer coupling more frequently employed.

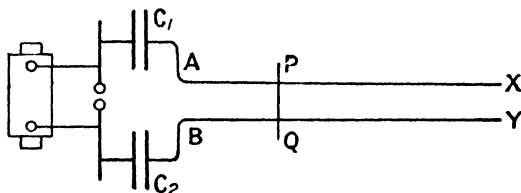

FIG. 392.

There will consequently be a point of maximum variation of potential at each end of the wires, which therefore behave in an analogous manner to the open organ-pipe in the acoustical problem. Remembering that the wave along AX starts in opposite phase to that along BY, we may represent the fundamental steady vibration by the full-line curves in Fig. 393, and we see that nodes are situated at C and D.

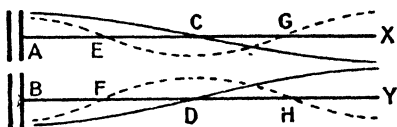

FIG. 393.

The first harmonic is given by the dotted curves, the nodes occurring at EF and GH. The nodes are found by placing a vacuum tube across the wires; this glows most brightly at the antinodes and ceases to glow at the nodes. A neon tube is most effective. If the conducting bridge PQ be placed across the wires, the variations in potential between X and Y will be a maximum when the bridge is situated at one of the nodes, in which case the wires may be looked upon as two circuits XPQY and C₁APQBC₂, having a common part PQ.

Cymometers.—The name “cymometer” has been given by Prof. J. A. Fleming to an apparatus for measuring the frequency of electrical oscillations. The earliest form was used for finding the frequency of oscillations in a circuit by connecting one end of a helix to a point of the circuit, a condenser being introduced at the point of contact. A sliding contact earths a point on the helix, and the contact is moved until two loops of the steady oscillation curve can be located by means of the neon tube. The wave-length λ in the helix being therefore known, and the velocity of propagation in the helix being $\frac{1}{\sqrt{L_1 C_1}}$, where L_1 and C_1 are the inductance and capacity per unit length of it, we obtain for the frequency (n);

$$n = \frac{1}{\lambda \sqrt{L_1 C_1}}$$

Or the cymometer may be calibrated directly by finding the wave length λ in the helix corresponding to the oscillations in a circuit of known capacity and inductance.

A more recent form of the instrument is shown diagrammatically in Fig. 394. The condenser IO is of the cylindrical pattern, the dielectric being a tube of ebonite. The outer coating OO slides easily on the ebonite tube, and attached to it so as to slide with it is a contact maker, K, which moves along the helix LD. The inner conductor I of the condenser is connected to the end D of the helix by the stout

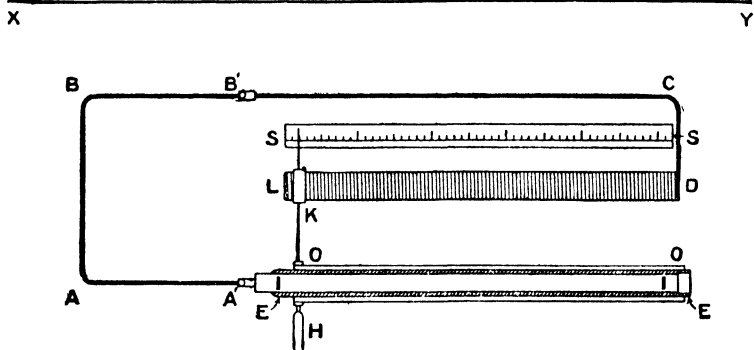

FIG. 394.

(From Fleming's "Manual of Radiotelegraphy.")

copper conductor A'ABB'C'D. By this arrangement the capacity and inductance can be diminished, both in the same ratio, by sliding OO and K to the right by means of the handle H. When the conductor ABC is placed near the circuit XY in which oscillations are occurring, forced oscillations occur in the circuit of the cymometer, which reach a maximum when its natural period of oscillation $\frac{1}{2\pi\sqrt{LC}}$ is the same as that of the oscillations to be measured. The current in the cymometer is then a maximum, and this condition is indicated by the glow in a neon tube connected to the coatings of the condenser. The position of the pointer on the scale S for this condition is found by trial, and the scale having been previously calibrated in frequencies, that of the oscillatory circuit is known.

Another device for indicating the condition of syntony, or maximum current in the cymometer, consists in inserting a short length of high-resistance wire somewhere in the part ABC of the circuit, and placing in contact with it a thermal junction of bismuth and iron, in series with a low-resistance galvanometer. The point of resonance is then indicated by the galvanometer deflection being a maximum. This

xiv. DETERMINATION OF DIELECTRIC CONSTANT 461

arrangement is shown in Fig. 395, in which a cymometer having two condensers in parallel is indicated.

The cymometer of this kind has the great advantage that, not being connected with the circuit the frequency of whose oscillations is to be measured, the disturbance produced by the instrument itself

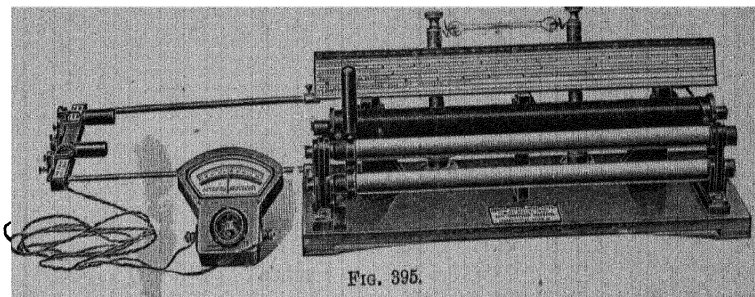

FIG. 395.

is inappreciable. This form of instrument has been designed for the measurement of frequencies from 50,000 to 5,000,000.

Other forms of cymometer have been designed, but for their description the student is referred to the larger works on radio-teleggraphy.

The cymometer may also be used for comparing small inductances with corresponding small capacities, for if the two are connected in series with a spark gap, as shown in Fig. 396, and the conductor of the cymometer placed near the inductance, then, on causing oscillations to occur in this circuit, the cymometer may be tuned to syntonny with the oscillatory circuit, and the frequency, n , therefore found.

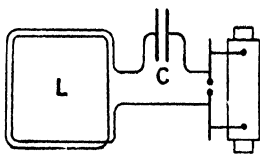

FIG. 396.

Then,

$$n = \frac{1}{2\pi\sqrt{LC}}$$

If either L or C be known, the other may then be calculated.

Determination of Dielectric Constant by Oscillations.—The natural period of oscillation of a circuit, since it depends upon the capacity in the circuit, affords a means of determining the latter when the period of oscillation can be found. Prof. J. J. Thomson¹ employed a parallel plate condenser, A (Fig. 397), near the plates of which are two flat conductors, E and F , to which the parallel wires EG and FI are connected. At each spark discharge at S , oscillations occur, and the periodic difference of potential between E and F originates waves

¹ J. J. Thomson, *Phil. Mag.*, 30, p. 129. 1890.

which travel down EG and FH. One of the spark knobs at S' is connected to the wire EG at L, and the other to a movable contact M such that no spark occurs at S'. Then M is always in opposite phase L. Similarly, a neighbouring point N is found for the same condition to be fulfilled. The distance MN is therefore one wave-length, since the phases at M and N are always the same.

The space between the plates A is now filled with the dielectric to

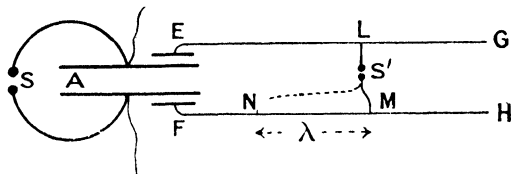

FIG. 397.

be examined, and a new length M'N' found, to correspond to the new wave length λ' . Since the velocity of propagation of the wave in the wires is constant,

$$n\lambda = n'\lambda' = V.$$

$$\text{But, } n = \frac{1}{2\pi\sqrt{LC}}, \text{ and, } n' = \frac{1}{2\pi\sqrt{L'C'}}$$

$$\therefore \frac{\lambda}{\lambda'} = \sqrt{\frac{C}{C'}}, \text{ and since } C_1 = kC, \frac{\lambda}{\lambda'} = \frac{1}{\sqrt{k}},$$

where k is the dielectric constant to be found. If the capacity C_1 of the rest of the circuit is also to be taken into account,

$$\frac{\lambda}{\lambda'} = \sqrt{\frac{C + C_1}{kC + C_1}}$$

Also, using parallel wires, Lecher¹ found the length of the wires, which, together with the condenser, form a circuit which is in sympathy with a given source of oscillations. When the tube A containing a rarefied

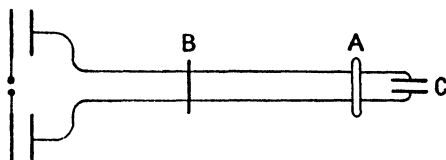

FIG. 398.

A again glows. The plates of the condenser C are adjustable, and in introducing the dielectric between them, A ceases to glow, but the

¹ E. Lecher, *Wied. Ann.*, 42, p. 142. 1891.

plates are pushed together through a known distance until the initial value of the capacity is restored, as will be indicated by A again glowing. The dielectric constant of the medium may then be calculated as on p. 166.

The cymometer may also be employed in determining the dielectric constant, particularly in the case of liquids, for the capacity of a condenser may be measured when air is the dielectric, and the air then replaced by the liquid whose dielectric constant is required, and the capacity again measured.

Coefficient of Coupling.—In the case of a transformer, the mutual inductance M is always less than the quantity $\sqrt{L_1 L_2}$, where L_1 and L_2 are the self-inductances of the primary and secondary coils (see p. 363).

The quantity $\frac{M}{\sqrt{L_1 L_2}}$ is called the coefficient of coupling of the primary and secondary circuits. It may be found¹ by means of the cymometer by the aid of a standard condenser. On joining the two coils of the transformer in series we have an effective inductance of $L_1 + 2M + L_2$ or $L_1 - 2M + L_2$, according to whether the connection is such that the mutual inductance produces an effect which helps or opposes that of the self-inductance. These two quantities may be found by means of the cymometer as described above, and also the larger of the two self-inductances.

$$\begin{aligned} \text{Then, if} & \quad P = L_1 + 2M + L_2 \\ \text{and} & \quad Q = L_1 - 2M + L_2 \\ \text{then,} & \quad M = \frac{P - Q}{4} \\ \text{and} & \quad L_1 + L_2 = \frac{P + Q}{2}, \end{aligned}$$

And since L_1 , say, is also found,

$$\begin{aligned} L_2 &= \frac{P + Q}{2} - L_1, \\ \text{and, coefficient of coupling} &= \frac{M}{\sqrt{L_1 L_2}}. \end{aligned}$$

¹ J. A. Fleming, *Proc. Phys. Soc.*, 19, p. 608. 1905.

CHAPTER XV

CONDUCTION IN GASES

Spark Discharge.—The passage of an electric current across an air gap between two metallic conductors has been mentioned several times. At the atmospheric pressure, the difference of potential between the conductors required to start the current is quite different to that required to maintain it, and depends upon the shape of the electrodes employed. A sharp point facilitates the discharge, as we should expect from the fact that the potential gradient in the neighbourhood is usually very great (p. 138). It is therefore necessary, when making measurements of sparking potential, to use for electrodes, polished spheres of diameter which is considerable in relation to the length of the spark gap. The low resistance of the gap found in the experiments on oscillations (p. 447) bears no relation to the potential difference required to start the discharge, for when the current has passed for a short time, the gap is occupied by a quantity of highly conducting material derived partly from the gas and partly from the metallic electrodes.

It is therefore evident that Ohm's law is not applicable to the discharge; we must leave until later, an examination of the relation between electromotive force and current.

The difference of potential between the electrodes required to start the discharge, and known as the spark potential, is independent of the metal of which the electrodes are made, except in the case of aluminium and magnesium, which metals have, under similar conditions, a less spark potential than the others, and for moderately great spark lengths the equation $V = a + bd$ represents fairly well the relation between spark potential V and

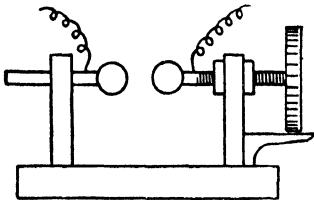

FIG. 399.

spark length d . For the measurement of d , some form of spinterometer (Fig. 399) is employed, in which one of the knobs is made to travel by means of a micrometer screw. The potential difference is measured by means of an electrostatic voltmeter. The apparatus requires modification when the spark potential in a gas other than air is required.

As the spark becomes very small, the spark potential again increases, and has therefore a minimum, which occurs at some particular spark length whose value varies inversely as the gas pressure. At the atmospheric pressure this critical spark length is about 0.01 millimetre, and is therefore difficult to measure; but by lowering the pressure to about a millimetre of mercury, the critical spark length becomes of the order of 8 mm., and may then be easily measured. The curve in Fig. 400 indicates roughly the relation between V and d for very short gaps. The fact of the existence of the critical spark length may be shown by bringing the spark knobs together until their nearest points are at less

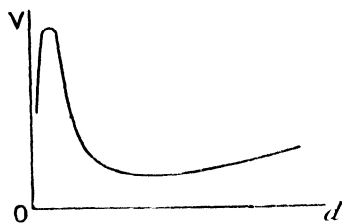

FIG. 400.

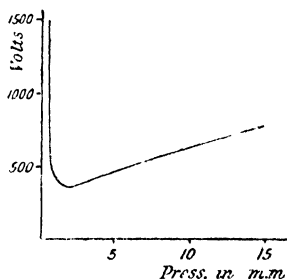

FIG. 401.

than the critical distance apart. The spark will not then take place between the nearest points, but will move to a place where the distance apart of the spherical surfaces is the critical distance.

As the pressure is varied, the spark potential at first falls and then rises, a minimum occurring at some pressure called the critical pressure. The mode of variation of potential difference and pressure for a moderate spark length of 3 mm. is shown in Fig. 401.

Paschen's Law.¹—According to Paschen, the spark potential is proportional to the amount of gas between the knobs, that is, to the product of spark length and gas pressure. His measurements were all made at pressures above the critical pressure. Carr² has shown that the law holds good also at pressures below the critical pressure. Hence, if the relation between spark potential and pressure be known for one spark length, it may be calculated for all others.

Discharge at Low Pressure.—The measurements concerning the electric spark which we have described above, do not involve any detailed knowledge of the processes going on, and we should probably still be in ignorance as to their nature if it were not for the Sprengel air-pump, the first to allow the attainment of very low pressures in glass bulbs.

¹ F. Paschen, *Wied. Ann.*, **37**, p. 69. 1889.

² W. R. Carr, *Proc. Roy. Soc.*, **71**, p. 374. 1903.

If the discharge between two conductors be maintained by means of a source of sufficiently high electromotive force, while the air pressure be continually reduced, the crackling nature of the discharge will after a time cease, and its path broadens out, giving a silent streamer whose colour varies with the gas employed, but generally changes from the white of the discharge at atmospheric pressure. At this stage a difference between the two ends of the discharge is noticeable, a discontinuity near the kathode being observable. This difference between the two ends becomes more accentuated as the pressure is further decreased, and the main part of the discharge will soon be seen to become stratified, and consist of layers of luminosity, separated by dark spaces. At a pressure of about 0.11 mm. of mercury, the discharge in hydrogen has the typical form shown in Fig. 402 (i), after De La Rue and Müller,¹ but the actual appearance of it cannot be described; it must be seen to be appreciated.

The discontinuity already observed near the kathode has increased considerably in size, and is called the Faraday dark space. Between it and the kathode is a luminous space called the kathode glow, and between this and the kathode may now be seen a sharply defined dark space called the Crookes or kathode dark space. The positive column consisting of the striations extends from the Faraday dark space up to the anode.

On further reduction of the pressure, the scale of the phenomenon is enlarged, the growth taking place from the kathode, and the positive column getting shorter and shorter and eventually disappearing as the Crookes dark space and the kathode glow expand. Fig. 402 (iv) shows the condition of the tube when there are still eight striations remaining, the pressure being then reduced to 0.037 mm. The phenomena at the kathode appear to be essential to the discharge, the positive column being accessory. At high pressures the separate parts of the discharge are so minute that their structure cannot be observed, but as the pressure is reduced, the mean free path of the molecules of the gas is larger, and the phenomenon of the discharge occurs on a larger and larger scale.

The boundary of the Crookes dark space is always luminous. When the boundary lies within the gas, we get there the kathode glow, but on reducing the pressure until the Crookes dark space extends to the glass walls of the tube a bright phosphorescence is seen, the colour of which depends upon the nature of the glass of which the tube is made. It is a bright yellow-green in the case of soda glass, and a grey-blue for lead glass. Many minerals exhibit brilliant phosphorescence of various colours, when situated in this dark space.

The whole of the time that the pressure has been falling, the resistance of the tube has been decreasing. The fall of potential required to produce the discharge gets less and less, until the Crookes dark space

¹ W. De La Rue and H. W. Müller, *Phil. Trans.*, 169, p. 155. 1878.

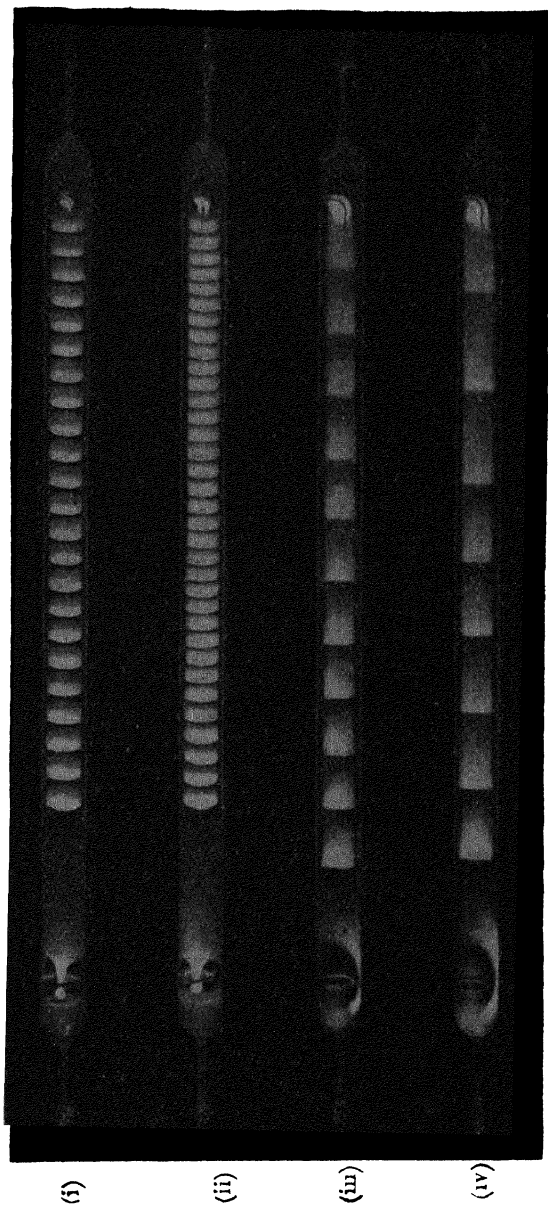

Fig. 402.

reaches the walls of the tube ; but an increase in the discharge potential then begins, and at the highest vacuum attainable it is almost impossible to get a discharge through the tube.

Kathode Rays.—The phenomena occurring in the kathode dark space appear to be produced by something emitted by the kathode and travelling with great velocity, to which the name of kathode rays has been given ; they were investigated systematically by Sir William Crookes. We will here note, in addition to their power of exciting phosphorescence, some important properties.

(i) The kathode rays travel in straight lines ; which fact may be

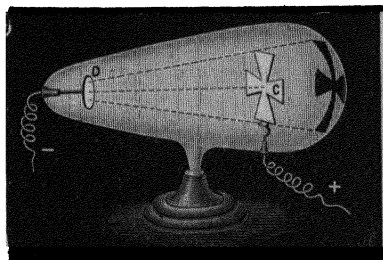

FIG. 403.

be observed by placing an obstacle in their path. Crookes placed a mica vane in the shape of a cross in the tube (Fig. 403), which will produce a dark shadow of its own shape upon the wall of the tube. By shaking down the cross after the phosphorescence has been produced for some time, the shape will still be seen, but it is now brighter than the surrounding part : of the glass, showing that

after a time the glass surrounding the shadow has become "fatigued" by exhibiting the phosphorescence.

(ii) A body placed in the path of the rays experiences a mechanical force acting in a direction away from the kathode. If the rays impinge upon the upper face of the little mica mill wheel (Fig. 404), which is mounted upon an axle running upon horizontal rails, the wheel is rotated

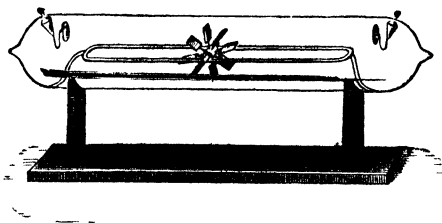

FIG. 404.

and may be driven from one end of the rails to the other. Sir J. J. Thomson has shown that the effect is not a purely mechanical one, the momentum of the rays being insufficient to produce the observed effect, but is probably due to the heating of the side of the mica upon which they

impinge, the phenomenon being similar to that in the Crookes radiometer.

(iii) The rays produce heat when falling upon matter. If the kathode be concave in form, the rays being emitted normally from it are brought to a focus, and a thin piece of platinum or other substance may be raised to incandescence if situated at this point.

(iv) Kathode rays are deflected by a magnetic field exactly as an electric current would be; that is, they are moved in a direction at right angles to their own path and to the magnetic field. This effect may be exhibited by using a tube such as that shown in Fig. 408, where the beam of kathode rays may be deflected up or down by means of a magnetic field, the motion being observed by watching the position of the phosphorescent patch where the rays fall on the wall of the tube. On bringing the pole of a bar magnet near the tube, the beam becomes curved upwards or downwards according to the sign of the pole employed. The direction of deflection is indicated in Fig. 408. It may be determined by the left-hand rule given on p. 239 *if the sign of the current from the kathode be taken as negative.*

(v) The rays are accompanied by a negative charge. Perrin¹ allowed the beam of kathode rays (Fig. 405) to pass into a hollow metallic cup, A, connected with an electrometer or electroscope. The instrument

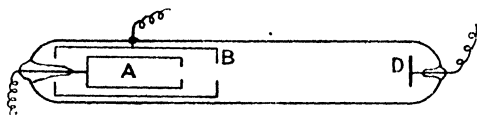

FIG. 405.

rapidly receives a negative charge, but a limit is soon reached owing to the gas in the discharge tube becoming conducting. If the sheath B be the kathode, and D the anode, A then acquires a positive charge, showing that positively charged bodies are moving in the opposite direction to the kathode rays. This point will be dealt with later.

The above effects are explicable on the assumption that the kathode rays are streams of electrically charged particles, which acquire a very high velocity in the electric field maintaining the discharge. These bodies were called negative corpuscles by Sir J. J. Thomson, and subsequent investigation has shown that they are of very wide occurrence.

Wehnelt Kathode.—By substituting for the platinum electrode, lime or one of the alkaline earths at high temperature, Wehnelt² showed that copious kathode rays can be obtained by means of comparatively low voltages. The lime or other oxide which is to form the kathode is placed upon a strip of platinum which is heated by means of an auxiliary current. Negative corpuscles are emitted by the oxide, which render it possible to send currents of 0.1 ampere through the tube with a p.d. of 100 volts. The corpuscles emitted have, on this account, comparatively low velocities of the order of 10^8 cm. per sec. (compare p. 473).

Röntgen or X Rays.—It was observed by Röntgen that a photographic plate situated near a discharge tube of high vacuum, was

¹ J. Perrin, *Comptes Rendus*, 121, p. 1130. 1895.

² A. Wehnelt, *Phil. Mag.*, 10, p. 80, July, 1905.

affected as though it had been exposed to ordinary light. Investigation showed that the emission which produced this effect proceeded from the walls of the vacuum tube upon which the kathode rays fell. Owing to their unknown nature Rontgen called them "X" rays, and the name Rontgen rays has also been given to them.

In addition to producing photographic effects, the Röntgen rays excite phosphorescence in many substances, notably, the platino-cyanides. Hence, a sheet of cardboard covered with a layer of barium platino-cyanide forms a convenient arrangement for rendering the presence of the rays obvious.

The Röntgen rays are not refracted on passing from one medium to another, thus differing from ordinary light waves; and they are also unaffected by a magnetic field, which fact differentiates them from the kathode rays. Their most important characteristic, apart from their power of exciting phosphorescence, is their penetrability for ordinary matter. The absorption of the rays by matter is dependent upon the density of the body upon which they fall, and hence the well-known application of the rays for producing shadows of the bones in the human frame, the flesh and portions of less density being the more transparent for them.

The rays produced in different vacuum tubes differ in character, the penetrating power being greater when the vacuum is higher. The highly penetrating rays from the tube of high vacuum are often spoken of as "hard" rays, and the relatively less penetrating rays from a tube of not so high a vacuum, as "soft" rays.

The explanation of the Röntgen rays given by Sir George Stokes is that they are electrical impulses of exceedingly small thickness produced by the sudden stoppage of the negative corpuscle of the kathode ray on meeting an atom. It was shown by Heaviside (p. 531) that on the sudden stoppage of an electric charge, a plane sheet of electromagnetic impulse continues to move forward with the velocity of light. This explanation is incomplete, as it is now known that they are of the nature of light waves of very short wave-length (p. 562). It is supported by experiments of Blondlot,¹ which tend to show that the velocity of the Rontgen rays is equal to that of light. Also it is found that the higher the vacuum in the tube from which the rays arise, the greater is their penetrability, which would follow from the fact that the higher the vacuum the higher is the voltage required to produce discharge, and therefore the greater will be the velocity of the negative corpuscles in the kathode rays (also see p. 530) and the less the interval of time in which they are brought to rest.

That the Röntgen rays arise at the point where the kathode rays strike a solid obstacle may be seen from the fact that the shadows cast by the rays arising where the kathode rays strike the walls of a vacuum tube are blurred; but if a concave kathode be used, and the

¹ R. Blondlot, *Comptes Rendus*, 135, p. 666. 1902.

kathode rays thereby focussed on a platinum plate A (Fig. 406), and a photograph obtained by placing a sheet of tin-foil, C, having a number of pinholes made in it, over the photographic plate D, then, on developing D and replacing it, it will be found that the lines *fe*, *hg*, etc., when produced backwards, converge upon some point A, showing that the Röntgen rays proceeded from this point. The tube shown is of the type generally employed for producing photographs, as the smallness of the source of the Röntgen rays renders it possible to produce shadows having extremely good definition.

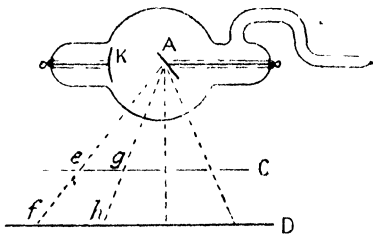

FIG. 406.

renders it possible to produce shadows having extremely good definition.

Secondary Röntgen Rays.—When the Röntgen rays fall upon any material, other rays of a similar character arise, to which the name of “Secondary X Rays” has been given. It was found by Sagnac¹ that when Röntgen rays fall upon a metal, they give rise to secondary rays, but that these secondary rays have less penetrating power than the primary rays, and Curie and Sagnac² found, further, that these secondary rays from the heavy metals carry a negative charge and leave a positive charge upon the metal. Professor Barkla³ found that all gases, upon which the Röntgen rays fall, emit secondary rays of the same penetrating power as the primary rays, and that the secondary rays from solid substances are sometimes polarised. It is now known that three kinds of ray are emitted, namely, scattered X-rays, characteristic X-rays which differ for different materials, and corpuscular rays consisting of negatively charged bodies.

It has been found that the intensity of emission of the corpuscular rays is greater the higher the atomic weight of the material. They are not emitted uniformly in all directions, being most freely emitted in a direction perpendicular to that of the X-ray beam. Their velocity does not appear to depend much upon the nature of the metal from which they arise, nor upon the distance of the X-ray tube from the material. For a number of different metals, including zinc, platinum, and lead, the velocity of these negative corpuscles ranges between 6.0×10^9 cm. per sec. and 8.3×10^9 cm. per sec. It is thus about twice as great as those for the kathode rays given on p. 473.

For an account of characteristic secondary radiation see Appendix, p. 561.

Determination of Velocity and Ratio of Mass to Charge of the Corpuscles constituting the Kathode Rays.—On the assumption that the kathode rays consist of negatively charged corpuscles moving with

¹ G. Sagnac, *Comptes Rendus*, 125, p. 942. 1897.

² P. Curie and G. Sagnac, *Journ. de Physique*, 1, p. 13, Jan. 1902.

³ C. G. Barkla, *Phil. Mag.*, 5, p. 685 (1903); 11, p. 812 (1906); and *P. Roy. Soc.*, 77, p. 247 (1906).

high velocity, it becomes necessary to determine the three quantities, velocity, mass, and charge associated with the corpuscle. The velocity and the ratio of mass to charge may be determined without great difficulty, but the determination of the actual mass and charge is more troublesome.

If e be the charge associated with the corpuscle, and v its velocity, we may consider it to constitute a current of strength ev . In a magnetic field of strength H , at right angles to the direction of motion, the force acting at right angles to both field and current is Hev . A body which experiences a force always at right angles to its direction of motion describes a circular path, and the normal acceleration being $\frac{v^2}{r}$, where r is the radius of the path, the force is $\frac{mv^2}{r}$, m being the mass of the body. Hence the equation of motion for a corpuscle in a magnetic field is

$$\frac{mv^2}{r} = Hev, \text{ or, } \frac{mv}{e} = Hr.$$

If, then, the stream of cathode rays produced by the cathode K , (Fig. 407), and limited by the metal blocks A and B having horizontal

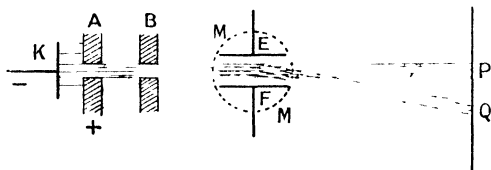

FIG. 407.

slots, pass through a magnetic field restricted to the circular space MM , then in passing through the field they will describe arcs of circles, the radius of which may be determined from the difference in position, PQ , of the patch on the phosphorescent luminous screen when the magnet field is on and when it is off. Thus H and r being known, the quantity $\frac{mv}{e}$ can be found.

Again, if the rays in their path have to traverse an electrostatic field due to the plates E and F maintained at a high difference of potential, the corpuscles experience a force eV while in the field, V being the electric intensity between the plates. If this electric field be at right angles to the magnetic field of the last experiment, and its intensity be arranged so that the force on the corpuscles is equal and opposite to that of the magnetic field, $eV = Hev$, or $\frac{V}{H} = v$; the corpuscle will now be undeviated so long as it is passing through the two fields

The fields are arranged to occupy the same part of the path, and are so varied in strength that the phosphorescent patch occupies its undisturbed position at the end of the tube. We then have $v = \frac{V}{H}$, and the velocity of the corpuscle is known. From the first experiment with the magnetic field alone, $\frac{mv}{e}$ is known, and therefore $\frac{m}{e}$ can be calculated.

By this method Sir J. J. Thomson,¹ to whom the method is due, obtained the following results:—

Gas.	v .	$\frac{mv}{e}$	Gas.	v .	$\frac{m}{e}$
Air . . .	2.8×10^9	1.3×10^{-7}	Air ² . . .	2.8×10^9	1.1×10^{-7}
Air . . .	2.8×10^9	1.1×10^{-7}	Hydrogen .	2.5×10^9	1.5×10^{-7}
Air . . .	2.3×10^9	1.2×10^{-7}	CO ₂ . . .	2.2×10^9	1.5×10^{-7}
Air ² . . .	3.6×10^9	1.3×10^{-7}			

The values of v vary, as would be expected, since v depends upon a number of conditions, but the values of $\frac{m}{e}$ do not differ very much from the mean, 1.3×10^{-7} , which indicates that the corpuscles are of the same kind whatever the gas employed, or the metal used for electrodes.

Determination of $\frac{m}{e}$ and v by Energy of Rays.— Sir J. J. Thomson²

obtained measurements of these quantities by another method. The charge carried by a beam of the cathode rays in a given time is determined by means of the electrometer, and the energy of the beam by means of its heating effect. The thin beam of cathode rays is deflected into a metallic cup A (Fig. 408) by means of a magnet. If N corpuscles enter the cup per second, then Ne is the charge given to the cup per second. Calling this Q , we have $Ne = Q$, and Q is measured by the rate of change of potential, as indicated by the quadrant electrometer, the capacity of the system being known.

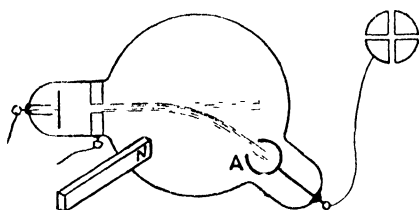

FIG. 408.

¹ J. J. Thomson, *Phil. Mag.*, **44**, p. 293. 1897.

² Platinum electrodes, the others being of aluminium.

³ J. J. Thomson, *loc. cit.*

The rays on entering the cup fall upon one junction of a thermal couple in series with a galvanometer, so that the rate of rise in temperature of the junction due to the bombardment by the rays could be determined. If, then, the heat capacity of the thermal couple can be estimated, the energy per second, W , given up by the rays is known. If, again, N be the number of corpuscles falling on the junction per second and $\frac{1}{2}mv^2$ the kinetic energy of each, and if the heat produced is derived from the kinetic energy of the corpuscles—

$$\frac{1}{2}mv^2N = W.$$

Eliminating N from this and the last equation, we have—

$$\frac{1}{2}mv^2 \frac{Q}{e} = W, \quad \text{or,} \quad \frac{m}{e} \cdot Qv^2 = 2W.$$

Now, from the experiment on the curvature of the path in the magnetic field we have—

$$\begin{aligned} \frac{m}{e} \cdot v &= Hr \\ &= \frac{2W}{Hr} \\ \therefore Qv &= \frac{2W}{Hr} \\ \text{or,} \quad v &= \frac{2W}{QHr} \\ \text{and,} \quad \frac{m}{e} &= \frac{Q(Hr)^2}{2W}. \end{aligned}$$

The mean value obtained by this method is $\frac{m}{e} = 0.86 \times 10^{-7}$, the difference between this and the results on p. 473 being probably due to uncertainty in the thermal measurements.

This ratio $\frac{m}{e}$ given by these methods, or the mass associated with unit charge, plays a part similar to that of the electro-chemical equivalent in electrolysis. Remembering that the same quantity for hydrogen is 0.0001044, we see that for the kathode rays the electro-chemical equivalent is of the order of $\frac{1}{1000}$ of that for hydrogen. Three possibilities then present themselves: (i) there may be no simple relation between the mass of the hydrogen atom and of the corpuscle of the kathode rays on the one hand, or between the charges carried by them on the other; or (ii) if the masses are of the same order, the charge carried by the corpuscle is of the order of 1000 times that carried by the hydrogen ion in electrolysis; or (iii) if the charges are of the same order, the mass of the corpuscle is of the order of $\frac{1}{1000}$ that of the hydrogen atom. The question can only be settled by further experiment (see p. 486), but we may anticipate so far as to say that (iii) ultimately turned out to be near the truth. There is now every

reason to believe that the electric charge met with in the case of the electrolytic monovalent ion and in the corpuscle of the kathode rays is the ultimate and indivisible unit of electricity. Whether the corpuscle of the kathode rays is a small portion of "matter" with this charge associated with it, or whether it merely *is* the charge, is a question that we cannot enter into now. The name of *Electron* was suggested by Dr. Johnston Stoney for this fundamental unit of electrical charge first met with in the kathode rays, and the name is now universally adopted. We shall presently see that electrons are constituents of all matter, and play an important part in phenomena where their presence was unsuspected until after their discovery in the vacuum tube.

Method of Leakage in Ultra-violet Light.—It was found by Hallwachs¹ and others, that when ultra-violet light falls upon the negatively electrified surface of a sheet of zinc, the surface rapidly loses its negative charge; but if it be positively charged, there is no loss. This is explained if negative corpuscles are detached by the ultra-violet light from the surface, their repulsion from the negatively charged surface constituting the loss which is observed to take place. When the surface is positively charged the corpuscles are not driven away, and there is of course no loss.

Sir J. J. Thomson² made use of this phenomenon to determine the value of $\frac{m}{e}$ for these corpuscles, and found it to be of the same order of magnitude as for those in the kathode rays, which makes it presumable that the two are identical in kind.

A magnetic field, H , parallel to the negatively charged surface is maintained, and the paths of the corpuscles are thereby modified. Taking the value of the electric intensity due to the charge on the surface as V , the force on each corpuscle due to this field is Ve and is directed away from the surface, since the charge of the corpuscle is negative. If the magnetic field H be directed from front to back (Fig. 409), the force on the corpuscle is Hev and is directed downwards. After leaving the surface the velocity will no longer be normal to it.

Taking the axis of x normal to the surface and the axis of y parallel to it and perpendicular to the magnetic field, the component of velocity parallel to Ox is $\frac{dx}{dt}$, and that parallel to Oy is $\frac{dy}{dt}$, and the

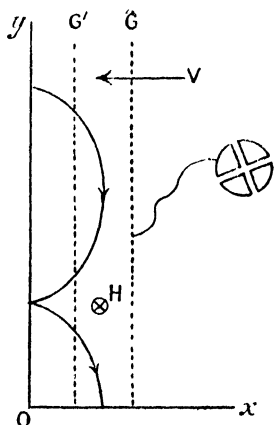

FIG. 409.

¹ W. Hallwachs, *Wied. Ann.*, **33**, p. 301. 1888.

² Sir J. J. Thomson, *Phil. Mag.*, **43**, p. 517. • 1899.

corresponding accelerations are $\frac{d^2x}{dt^2}$ and $\frac{d^2y}{dt^2}$. If m be the mass of the corpuscles, the forces parallel to Ox due to the fields are Ve and $He \cdot \frac{dy}{dt}$, and these are together the resultant force $m \frac{d^2x}{dt^2}$ acting on the corpuscle in the x direction. Applying the left-hand rule of p. 239, and remembering that the moving corpuscle corresponds to a negative current, we see that the corpuscle when moving downwards experiences a force directed towards the plate, due to the magnetic field. The force equation for the components parallel to Ox is—

$$m \frac{d^2x}{dt^2} = Ve - He \frac{dy}{dt}.$$

Again, since there is no component of V parallel to Oy , we have for this direction the equation—

$$m \frac{d^2y}{dt^2} = He \frac{dx}{dt}.$$

The solution of these two simultaneous equations is—

$$y = \frac{V}{\omega H} (\omega t - \sin \omega t)$$

$$x = \frac{V}{\omega H} (1 - \cos \omega t)$$

where $\omega = \frac{He}{m}$.

These are the equations of a cycloid formed by a circle rolling on the axis of y ; for if P be the point on the circle when in the axis of y , and P' the position of the point when the circle has rolled through angle θ (Fig. 410), the length AP and the arc AP' are equal, and the co-ordinates of P' are therefore $x = a(1 - \cos \theta)$ and $y = a\theta - a \sin \theta$. But if the circle roll with uniform angular velocity ω —

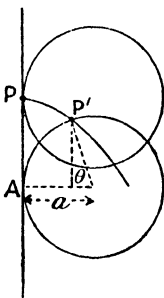

FIG. 410.

then,

$$\theta = \omega t ;$$

$$x = a(1 - \cos \omega t)$$

$$y = a(\omega t - \sin \omega t).$$

We see, then, that the moving corpuscle will describe a path similar to that of the point P upon the rolling circle, and its distance from the metallic surface will therefore never be greater than the diameter of the circle. By comparing the two sets of equations, we see that—

$$2a = \frac{2V}{\omega H} = 2 \cdot \frac{m}{e} \cdot \frac{V}{H^2}.$$

The conductor *Oy* is a zinc plate illuminated with ultra-violet light, for the liberation of the corpuscles. A parallel plate *G* (Fig. 409), connected to an electrometer, rapidly receives a negative charge when there is no transverse magnetic field, but with the field the corpuscles return to the plate *Oy*, and *G* does not receive any charge. In the position *G'*, the magnetic field does not affect the rate at which the charge is received. The limiting position is found, for which the field affects the rate at which *G* receives charge, and the distance between the plates is then $2a = 2 \frac{m}{e} \cdot \frac{V}{H^2}$. The limiting position is not so sharply defined as the equations indicate, but the mean value found for $\frac{m}{e}$ in this way is 1.4×10^{-7} , which is in fair agreement with the result given on p. 473.

Photo-electricity.—The Hallwachs phenomenon is only one case of the liberation of negative corpuscles when light falls upon matter. The effect is very widely observed, and to it is applied the term *photo-electricity*. Experiments conducted in a vacuum have given us much more intimate knowledge of the process than we had previously, and have led to the discoveries that (a) the velocity of the corpuscles emitted is independent of the intensity of the light, and (b) the rate of emission of the corpuscles is directly proportional to the intensity of the light. A measure of the positive potential acquired by the illuminated plate enables the velocity of the emitted corpuscles to be found, for the emission ceases when the electric intensity produced by the loss of negative electricity is sufficient to prevent the further escape of the corpuscles. Also the saturation current (p. 479) for a given p.d. between the illuminated plate and a parallel plate gives the number of corpuscles emitted per second. In the case of the alkali metals maximum photo-electric effect occurs for light belonging to the visible part of the spectrum. This is probably due to a *selective* effect for the metal, as, for the *normal* photo-electric effect, the shorter the wave-length of the light the greater is the emission. The plane of polarisation of the incident light also influences the rate of emission of the corpuscles.

The photo-electric phenomenon has been shown to be connected with those of fluorescence and phosphorescence as well as with that of the chemical changes occurring in the photographic plate. The subject is now such a large and important one that the student can only be referred to such works on it as that of H. S. Allen.¹

Ionisation.—Under ordinary circumstances, gases are very feeble conductors of electricity, a charged body situated in a gas retaining its charge for a very long time. Many agencies, however, render the gas a comparatively good conductor, amongst which may be mentioned, cathode rays, X-rays, hot bodies, flames, and radioactive substances (Chapter XVI.). Further, the conductivity persists

¹ H. S. Allen, "Photo-electricity." 1913.

for a time, but does not last indefinitely. Sir J. J. Thomson and Prof. Rutherford¹ showed that this conductivity may be removed in a variety of ways.

If the conductivity in the neighbourhood of the funnel A be produced by means of an X-ray tube enclosed in a box covered with lead sheet to screen its direct effect from the electroscope, and provided with a window B, then the air drawn through the tube CD, into the electroscope by means of an aspirator will cause the leaves to collapse, whether the sign of the charge upon them be positive or negative.

A plug of glass wool placed in the tube at C will remove the conductivity from the air. The same result is produced if the

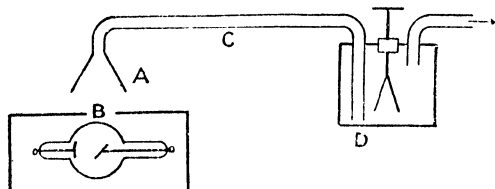

FIG. 411.

conducting air be bubbled through water. Whatever it is that renders the air conducting is therefore filtered from it by these processes. The conductivity also disappears when an electric current passes through the air, which was shown by using for C a metallic tube having a wire stretched along its axis, a high potential difference being maintained between the tube and the wire. The leaves of the electroscope in this case do not collapse, showing that the cause of the conductivity has been removed. It is concluded from this experiment that the cause of the conductivity consists in charged particles, since they are driven to the sides of the tube or to the wire by the electric field, and further, that since the conducting gas as a whole does not exhibit electrification, the charged particles have opposite signs, and are in equal electrical quantities. These electrified particles are called ions, and the process of their production *ionisation*.

Conduction in Ionised Gas.—The conductivity of the ionised gas may be determined by maintaining two parallel plates between which the gas is situated, at a known difference of potential, and the rate of change of potential of one of the plates determined by means of the quadrant electrometer.

If the capacity of the plate A (Fig. 412) and the electrometer be known, the rise in potential per second enables the current passing from B to A to be determined. It is found, on gradually raising the

¹ J. J. Thomson and E. Rutherford, *Phil. Mag.*, 42, p. 392. 1896.

applied difference of potential, that at first the current increases almost in accordance with Ohm's law, but the value of the current for further rise of potential difference falls below that indicated by Ohm's law, and eventually a value is reached for which the current does not further increase. This current is known as the saturation current (Fig. 413), and it is not exceeded until the electrical field is strong enough to

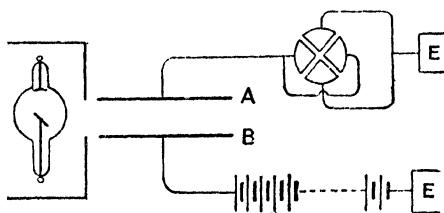

FIG. 412.

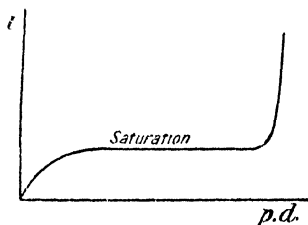

FIG. 413.

produce ionisation in the gas. When this stage is reached the current begins to increase rapidly.

Saturation Current.—The saturation current depends upon the total number of ions between the plates, which in its turn depends upon the rate of production of ions and upon the volume of air between the plates. For the current i to pass from one plate to the other $\frac{i}{e}$ positive ions are driven against one plate, and $\frac{i}{e}$ negative ions against the other, and if q positive and q negative ions are produced by the Röntgen rays in one cubic centimetre per second, the total number of each kind produced per second in the space between the plates is qAl , where l is the distance apart of the plates and A the area of each, then $\frac{i}{e}$ cannot exceed qAl , and for the saturation current

$$qAl = \frac{i}{e}$$

or,

$$qAle = i.$$

The saturation current is therefore proportional to the distance apart of the plates, and we have the remarkable result that for the same difference of potential between the plates, the current increases if the plates are drawn further apart. In their experiments on ionisation, Sir J. J. Thomson and Prof. Rutherford¹ showed that when the ionisation is produced by Röntgen rays, this condition is realised.

Decay of Ionisation.—The fact that the ionisation persists for some time after the air has been removed from the cause of ionisation:

¹ J. J. Thomson and E. Rutherford, *loc. cit.*

has already been noticed (p. 478). It will not, however, persist indefinitely, and Prof. Rutherford¹ has measured the rate of decay in several cases.

When a positive ion meets a negative ion the two may or may not become united to form a neutral body, the result of the collision depending upon the conditions under which the two meet. The number of collisions of a positive with a negative ion occurring in unit time is proportional to the number of either in unit volume of the gas. In the case in which there are n of each kind per unit volume, the number of collisions per second is proportional to n^2 , and if constant fraction a of these collisions result in the production of a neutral body, an^2 ions of each kind will disappear in unit time from this cause. If, then, q ions of each kind are produced by ionisation in unit volume of the gas per second, the rate of increase, $\frac{dn}{dt}$, of the number of ions of either kind present, is the difference between the number produced and the number disappearing.

$$\therefore \frac{dn}{dt} = q - an^2,$$

or,
$$\frac{dn}{dt} = a(k^2 - n^2), \text{ where } k^2 = \frac{q}{a}.$$

Then $\frac{dn}{k^2 - n^2} = a dt$, which may be written,

$$2k \frac{dn}{k+n} + 2k \frac{dn}{k-n} = a dt.$$

Integrating which equation, we get,

$$\log \frac{k+n}{k-n} = 2kat + C.$$

If we reckon time from the start of the process of ionisation, $n = 0$ when $t = 0$, and thus $C = 0$,

$$\therefore \log \frac{k+n}{k-n} = 2kat,$$

$$\frac{k+n}{k-n} = e^{2kat},$$

or,
$$n = k \frac{e^{2kat} - 1}{e^{2kat} + 1}.$$

After an infinite time the gas has reached a steady state; and

¹ E. Rutherford, *Phil. Mag.*, 44, p. 422. 1897.

putting $t = \infty$, and writing n_0 for the number of ions of each kind present in unit volume when this state is reached—

$$n_0 = k = \sqrt{\frac{q}{a}}.$$

The greater the values of q and a the sooner will the ionisation reach a steady state, for when ϵ^{2kat} is great in comparison with unity the numerator and denominator of the fraction are equal. This only happens when t is great in comparison with $\frac{1}{2ka}$ or $\frac{1}{2\sqrt{qa}}$.

To find the rate of decay of ionisation on the cessation of the Röntgen rays, put $q = 0$, when the above equation becomes—

$$\frac{dn}{dt} = -an^2.$$

Then,
$$\frac{dn}{n^2} = -adt, \quad \therefore -\frac{1}{n} = -at + C.$$

If now $n = n_0$ when $t = 0$,

$$C = -\frac{1}{n_0},$$

and,

$$\frac{1}{n} = at + \frac{1}{n_0}$$

or,

$$n = \frac{n_0}{1 + n_0 at}.$$

Rutherford verified this equation by cutting off the rays, and then applying a large electromotive force to the plates after a known interval of time, the processes being carried out by the swing of a pendulum, so that the time interval could be determined. The charge driven across to one of the plates by means of the electromotive force is a measure of the number of ions of one kind in the space between the plates, and is determined by finding the rise in potential of this plate by means of the electrometer. By taking various intervals of time between the cutting off of the Röntgen rays and the application of the high electromotive force, it was found that the last equation represented the fact.

If $t = \frac{1}{n_0 a}$, $n = \frac{n_0}{2}$, and the amount of ionisation has fallen to one half, and since $n_0 = \sqrt{\frac{q}{a}}$ (p. 480), $t = \frac{1}{\sqrt{qa}}$. By keeping the intensity of the Röntgen rays as nearly as possible constant, measuring the time for the ionisation to fall to half its steady value, when the rays are cut

off, and by observing the relative values of $n_0 = \sqrt{\frac{q}{a}}$ when the interval is extremely short, Rutherford found the following results:—

	Time for fall of ionisation to half.	q .	a .
Hydrogen	0.65	0.5	4.8
Air	0.3	1	11
HCl (gas)	0.35	11	0.75
CO ₂ (gas)	0.51	1.2	3.3
SO ₂	0.45	4	1.25
Chlorine	0.18	18	2

Charge upon Negative Ion.—The problem of the determination of the mass of the negative ion produced in gases was successfully solved in 1898 by Sir J. J. Thomson. The current maintained in the gas by a known electrical intensity is measured. If U be the velocity of drift of the ions in electrical field of unit intensity, and V the actual electrical intensity, VU is the velocity of the ions.

When the total number present is N and e the charge upon each, $NeVU$ is the current; and this can be measured. To determine N , a discovery by C. T. R. Wilson¹ was used, which consists in the fact that in supersaturated, dust-free air, condensation takes place upon the ions, and a cloud of minute drops is formed. These drops fall through the gas at a constant rate, from which their size can be found, and knowing the total quantity of moisture condensed from the work done in producing the adiabatic expansion necessary for the supercooling, N the number of drops can be found,

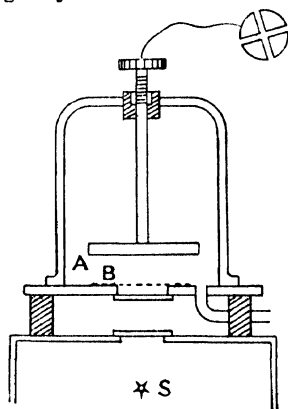

FIG. 414.

and consequently e the charge associated with each ion is known.

Several methods have been employed for the determination of U , the velocity of drift of the ions produced by an electrical field of unit intensity, but that of Rutherford² is probably the most interesting. The ions are liberated from the zinc plate A (Fig. 414) by ultraviolet light from the source S, the plate being connected to a quadrant electrometer. The light passes through a window covered by a sheet of gauze B, and between A and B an alternating electromotive force is

¹ C. T. R. Wilson, *Phil. Trans.*, A., 189, p. 265. 1897.

² E. Rutherford, *Proc. Camb. Phil. Soc.*, 9, p. 401. 1898.

applied. During half a period of alternation the negative ions are driven away from A towards B, and during the next half-period they are driven back again. Whether they reach B or not depends upon its distance from A. If they do not reach B they will return to A, which will not lose a negative charge, and the electrometer deflection will not change, but if they do reach B they will not return, and A will continually lose negative charge. The distance between A and B is therefore adjusted until A begins to lose charge, and measured by the micrometer screw. This is the distance travelled by the negative ions during one half-period of the alternating electromotive force.

If d is the distance between A and B, and $e_0 \sin pt$ the alternating electromotive force between them, $\frac{e_0 \sin pt}{d}$ is the potential gradient, or electric intensity at any instant. U being the velocity of the ions for unit electric intensity, their instantaneous velocity is $\frac{Ue_0 \sin pt}{d}$.

Taking x as the distance of any ion from A, $\frac{dx}{dt}$ is its velocity, and we have—

$$\frac{dx}{dt} = \frac{Ue_0 \sin pt}{d},$$

$$\therefore x = -\frac{1}{p} \cdot \frac{Ue_0}{d} \cos pt + C.$$

If $x = 0$ when $t = 0$, this means that the ion starts from the plate A,

and,
$$C = \frac{Ue_0}{pd},$$

so that,
$$x = \frac{Ue_0}{pd} (1 - \cos pt).$$

Now $\cos pt$ varies between the values $+1$ and -1 , and x is evidently a maximum when $\cos pt = -1$; and the greatest distance that the ion travels is—

$$\frac{2Ue_0}{pd}, \text{ or, } d = \frac{2Ue_0}{pd}, \quad \therefore U = \frac{pd^2}{2e_0}.$$

Rutherford found the following values for U when $\frac{e_0}{d}$ is less than 1 volt per cm. For air, $U = 1.4$ cm. per sec.; for hydrogen, 3.9 cms. per sec., and for CO_2 , 0.78 cm. per sec.

Other methods both for the ions liberated from zinc by ultra-violet light and for those produced by Röntgen rays give practically the same result; which fact helps to establish the identity of the ions produced in these various ways.

The *Condensation Experiments* of C. T. R. Wilson¹ showed that if air saturated with water vapour and free from dust be suddenly cooled by causing an expansion exceeding 1 : 1.25 in volume, the vapour condenses upon the negative ions, but if the expansion exceeds 1 : 1.3 the condensation takes place upon the positive as well as the negative ions.

The explanation of the condensation upon the ions was given by Sir J. J. Thomson.² It is shown in text-books on the Properties of Matter that the maximum vapour pressure of water over a convex surface is greater than that over a plane surface by the amount δp , where $\delta p = \frac{2T\rho}{a(\sigma - \rho)}$, T being the surface tension of the liquid surface, a its radius of curvature, σ the density of the liquid, and ρ that of the vapour. This change in the maximum vapour pressure is insignificant unless a the radius of curvature is exceedingly small, but when this is the case the rise in the maximum vapour pressure causes rapid evaporation. Thus the drop will not grow by condensation unless some body, such as a speck of dust is present, which presents a surface of sufficiently large radius of curvature for the initial stages of drop formation to be avoided.

By means of the gas equation $p\theta = R\theta$, or $p = R\theta\rho$, we may put the value of δp into the form

$$\delta p = \frac{2Tp}{R\theta a(\sigma - \rho)}, \text{ or, } \frac{\delta p}{p} = \frac{1}{R\theta} \left(\frac{2T}{a} \right) \frac{1}{\sigma - \rho}.$$

The quantity $\frac{2T}{a}$ is an inward pressure due to the surface tension of the drop. We saw on p. 132 that a surface density of electrification σ_1 causes an outward electrical pressure $\frac{2\pi\sigma_1^2}{k}$, and if e is the charge associated with a spherical drop on account of an ion at centre—

$$\sigma_1 = \frac{e}{4\pi a^2},$$

Therefore outward pressure due to charge q is $\frac{e^2}{8\pi k a^4}$.

If we attribute the change in maximum vapour pressure to the inward pressure $\frac{2T}{a}$ due to surface tension, we must now modify this by means of the outward pressure due to electrification, and we get—

$$\frac{\delta p}{p} = \frac{1}{R\theta} \left(\frac{2T}{a} - \frac{e^2}{8\pi k a^4} \right) \frac{1}{\sigma - \rho}.$$

¹ C. T. R. Wilson, *Phil. Trans.*, A., 193, p. 289. 1899.

² J. J. Thomson, "Applications of Dynamics to Physics and Chemistry," p. 165.

When a is exceedingly small the term $\frac{e^2}{8\pi ka^4}$ is more important than $\frac{2T}{a}$, and condensation will take place. When $\frac{2T}{a} = \frac{e^2}{8\pi ka^4}$ the maximum vapour pressure is equal to that over a plane surface, and it is not until the first term is the greater, that the effect of the electric charge in promoting condensation is less than the effect of surface tension in preventing it.

The gas under experiment is situated in A (Fig. 415), and is ionised by means of the Rontgen tube R. By maintaining a known difference

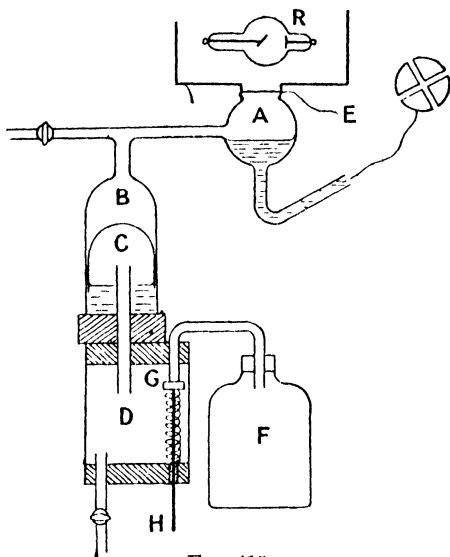

FIG. 415.

of potential between the surface of the water in A and the upper surface, the current $NeVU$ is maintained in the ionised gas, and this is measured by the rate of rise of potential $\frac{dE}{dt}$ of the electrometer. If

C be the capacity of the electrometer and vessel A,

$$C \frac{dE}{dt} = NeVU.$$

Everything in this equation is known except N and e , and the product Ne can therefore be found.

To determine N , a sudden expansion of the air in A is produced. To effect this, the tube B is provided with a loosely fitting piston C,

consisting of the end of a test tube. The lower part of B contains water, so that the piston is air-tight, and may be suddenly depressed by opening the valve G, which puts the vessel D in connection with a larger vessel F in which there is a partial vacuum. On causing the sudden expansion of the gas in A a cloud is formed by condensation upon the ions. The dust has previously been removed by producing a cloud and allowing the drops formed upon the dust particles to settle, the process being repeated until all the dust is removed and no cloud is formed on expansion.

The cloud formed when the gas is ionised is allowed to settle, and, the drops being of approximately constant size, they fall, all at the same rate, and the top of the cloud is clearly defined, affording by its descent a convenient means of determining the rate of fall of the individual drops. It has been shown by Sir George Stokes that the rate of fall in a spherical drop is $\frac{2}{9} \cdot \frac{ga^2}{\eta}$, where g is the acceleration of gravity, a the radius of the drop, and η the coefficient of viscosity of the gas. Hence a the radius, and from it the volume of each drop, can be found.

It only remains to find the total amount of vapour condensed during the expansion of the air, and we shall then know the number of drops formed.

The work done during an adiabatic expansion, per cubic centimetre of gas, can be found from the amount of expansion, knowing the ratio of the specific heat of the gas at constant pressure to that at constant volume; and, the latent heat and lowering of temperature of the air being known, the total amount of water condensed can be calculated. Thus N is found, and the product Ne being known from the current experiment, e is obtained.

In this way the value of e for the ions produced by Röntgen rays in air was found to be 6.5×10^{-10} electrostatic units or 2.16×10^{-20} electromagnetic units, and that for ions in hydrogen, 6.7×10^{-10} electrostatic or 2.23×10^{-20} electromagnetic units. On repeating the experiments in 1901-1902 Sir J. J. Thomson¹ found that with an expansion above 1:1.3 twice as many drops were formed as when the expansion was below 1:1.3, and it was concluded that with the greater expansion, the positive as well as the negative ions acted as nuclei of drops. With the new apparatus, and using various samples of radium to produce the ionisation, the value of e was found to be 3.4×10^{-10} electrostatic or 1.33×10^{-20} electromagnetic units.

C. T. R. Wilson has more recently obtained instantaneous cloud photographs, showing the passage of a beam of X-rays through super-saturated air. One of these is given in Fig. 416, in which the drops formed by condensation upon the individual ions liberated by the X rays can be seen.

¹ J. J. Thomson, *Phil. Mag.*, 5, p. 346. 1903.

Charge of the Electron.—The cloud method has been modified by Professor Millikan,¹ in such a way that the errors due to the assumption that the drops are all of one size, and do not vary in size by evaporation, and that the temperature is accurately known, are eliminated.

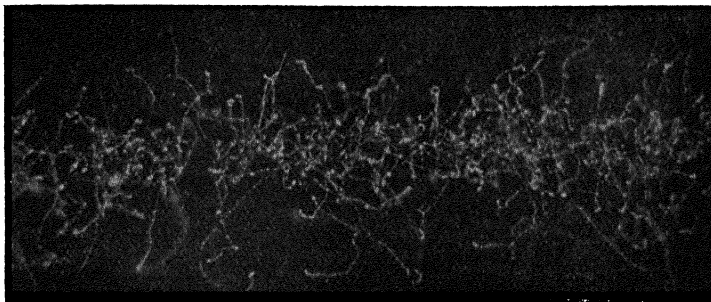

FIG. 416.

An electric field is maintained between the parallel plates, which produces a force Ve upon the drop where V is the electric intensity and e the charge upon the drop. The force upon the drop due to gravity is its weight mg , and when the electric and gravitational forces are in opposition the former may be adjusted until for certain drops $Ve = mg$, and the drop is then suspended in mid-air. The drops for which $Ve < mg$ fall upon the lower plate, and those for which $Ve > mg$ are driven upwards upon the upper plate. The drops are examined by means of a telescope of short focal length, and individual drops seen as bright points are in the above way singled out for observation. A drop could be maintained in equilibrium for 30 to 45 seconds.

After the ionisation had been produced by bringing near the tube a quantity of radium, the cloud produced and the single drop isolated, the electric field is removed, and the rate of fall of the drop as its image passes successive cross wires in the eyepiece of the telescope is measured.

Remembering that the rate of fall of a drop (v) is $\frac{2}{9} \cdot \frac{ga^2}{\eta}$, and that $m = \frac{4}{3}\pi a^3$, we see that

$$v = \frac{2}{9} \cdot \frac{g}{\eta} \cdot \left(\frac{3m}{4\pi}\right)^{\frac{2}{3}}, \text{ or, } \frac{3m}{4\pi} = \left(\frac{9}{2} \cdot \frac{\eta}{g}\right)^{\frac{3}{2}} v^{\frac{3}{2}}.$$

¹ R. A. Millikan, *Phil Mag.*, 19, p. 209. 1910.

But $Ve = mg$,

$$\therefore e = \frac{4\pi}{3} \left(\frac{9}{2} \cdot \frac{\eta}{g} \right)^{\frac{1}{2}} \frac{g}{V} v^{\frac{1}{2}}.$$

From the known values of g and of the viscosity of the air η , this equation may be reduced to

$$e = 3.422 \times 10^{-9} \frac{g}{V} v^{\frac{1}{2}}.$$

The value of e is found from a number of observations, the values given by single observations being multiples of 4.65×10^{-10} electrostatic or 1.55×10^{-20} electromagnetic units, which is therefore considered to be the value of the smallest ionic charge.

Taking the electromagnetic unit of electricity to liberate 0.0001044 gramme of hydrogen (p. 66) and the density of hydrogen at 0° C. and 760 mm. pressures to be 8.96×10^{-5} , we see that one electromagnetic unit of electricity liberates $\frac{0.0001044}{8.96 \times 10^{-5}} = 1.165$ cubic centimetres of

hydrogen at 15° C., and there are consequently 1.165N atoms of hydrogen liberated, where N is the number of atoms per cubic centimetre. If, then, E is the charge in electromagnetic units upon each

atom, $1.165 \times NE = 1$, or $NE = \frac{1}{1.165}$. From the kinetic theory of

gases it is concluded that N lies between 2×10^{19} and 10^{20} , and therefore E lies between 0.429×10^{-19} and 0.858×10^{-20} electromagnetic units; hence the electric charge associated with the ion in an ionised gas is the same as that upon the atom of hydrogen in an electrolytic

solution. The probable value of $\frac{e}{m}$, from the latest measurements,¹ is

probably 1.772×10^7 , or for $\frac{m}{e}$, 5.64×10^{-8} , where e is in electromagnetic units.

Since the electro-chemical equivalent of hydrogen is 1.044×10^{-4} and e is the same in the two cases, it follows that m is $\frac{5.64 \times 10^{-8}}{1.044 \times 10^{-4}} = \frac{1}{1850}$ of that of the atom of hydrogen.

Canal Rays.—In the cathode dark space, negative ions or corpuscles are driven away from the cathode with a velocity of the order of 10^9 cms. per second (p. 473). If, then, there are positive ions in the cathode dark space we should expect that they would be driven towards the cathode, but since they meet the cathode itself they would be undetected. The faint glow at the surface of the cathode is due to these positive ions, and further these rays carrying a positive charge have been noticed by Perrin (p. 469). If, however, the cathode consist of a thin sheet with perforations in it, the positive ions might then pass through these spaces and give rise to streams behind

¹ Kaye and Laby's Tables, 1911.

the kathode. Goldstein¹ observed such rays and called them "Kanalstrahlen," or Canal Rays. They can produce phosphorescence, and are deflected in a magnetic field, but the deflection is much less than in the case of the kathode rays.

Using the method of the combined magnetic and electrostatic fields (p. 472), W. Wien² determined the values of $\frac{m}{e}$ and v , and found that $\frac{m}{e} = 1.3 \times 10^{-3}$, and $v = 3.6 \times 10^7$ cm. per second. The magnetic deflection is much more difficult to obtain than in the case of the kathode rays, and much stronger fields were used. The velocity is only about $\frac{1}{100}$ of that of the kathode rays, while the value of $\frac{m}{e}$ is of the order of that of the hydrogen atom dealt with in electrolysis. The value of $\frac{m}{e}$ is not so constant as in the case of the kathode rays, but the smallest value found is 1.3×10^{-3} .

Radiation from Canal Rays.—Some interesting deductions regarding the emission of light by glowing gases have been made by J. Stark,³ by examining spectroscopically the light emitted by the canal rays. If the light which falls upon the slit of the spectroscope is received in a direction normal to the rays, the ordinary line spectrum of the gas in the tube is observed; but when the light is received in the direction of the rays, so that the positive ions are approaching the spectroscope, the spectrum lines are broadened towards the violet, in some cases leaving a dark interval between the normal position of the line and the displaced line. Stark considered that this effect is due to the velocity of approach of the emitters of the light of the line spectrum, in fact it is an exhibition of the Doppler effect. When the vibrating source is approaching the observer, more waves are received in unit time than when the source is at rest, and the result is an apparent increase in frequency or diminution of wave-length, which means that the lines of the spectrum will be displaced towards the violet end of the spectrum. It is shown in works on Optics that $\frac{\lambda - \lambda_1}{\lambda} = \frac{v_1}{v}$, where λ and λ_1 are the wave-lengths of the light when the source is at rest, and when approaching the observer with velocity v_1 , v being the velocity of light. Therefore $\lambda - \lambda_1 = \lambda \cdot \frac{v_1}{v}$, and if, in a given gas (say hydrogen), the positive ions of the canal rays are the emitters of the line spectrum, we should expect that all the lines would be displaced by the same amount. This was found by Stark to be the case, and he found a velocity for the ions of 1.2×10^8 cms. per

¹ Goldstein, *Berl. Sitz. Ber.*, p. 691. 1886.

² W. Wien, *Wied. Ann.*, 65, p. 440. 1898.

³ J. Stark, *Phys. Zeitschr.*, 6, December 15, 1905; *Nature*, 73, February 22, 1906; and *Phys. Zeitschr.*, 7, April 15, 1906.

second. From the existence of a dark interval between the normal position of the line and the displaced position it is concluded that the emission of the line spectrum does not begin until a certain velocity of the positive ions is reached.

Ionisation by Collision.—Many facts point to the conclusion that the ions which take part in the passage of currents through gases are to a large extent produced by the impact of ions already present, with the neutral atoms of the gas. An examination of the curve in Fig. 414 shows that when a certain electrical intensity of the field is reached, a large and rapid increase in the current takes place, and it is reasonable to suppose that this happens when the velocity of the ions due to the electric field is sufficient for them to ionise the neutral molecules of the gas on impact. The conditions for this to take place are complicated; at high pressures the collisions are so frequent that the ion will not have acquired a sufficient velocity before impact to enable it to produce ionisation, but on the other hand, if the potential gradient be very great, a much shorter path is required for this critical velocity to be produced. This is in accordance with the fact that at high pressures a much greater potential difference is required to produce a spark than at low pressures, the length of spark gap remaining the same.

If l be the mean length of path of the ion between collisions,

$$eXl = \frac{1}{2}m \cdot v^2,$$

since the work done on the ion by the electrical intensity X is equal to the kinetic energy acquired by the ion. We therefore see that the negative ion, having a much smaller mass than the positive ion, will acquire the ionising velocity in a much shorter path than the heavy positive ion, and therefore at the beginning of the discharge the negative ions will be the more important in producing ionisation. But the phenomenon is complicated by the fact that the positive ion may not require the same velocity to produce ionisation as the negative ion, and, further, since it is the larger, its collisions will be more frequent, and also the collisions do not take place under the same conditions. It is certain, however, that the ionising property is more nearly related to the velocity than to the kinetic energy, since experiment is in accord with the fact that the initial stages of the spark are determined by the negative and not the positive ions.¹

Process of Electric Discharge.—The process of the electric discharge may now be accounted for on the theory of ionisation by collision. When there is an electric field in the gas between two conductors, the current will be infinitesimal (although never actually zero), unless ions are produced by some external cause, such as Röntgen rays or ultra-violet light. When, however, the electric intensity reaches a certain value, any ions in the gas will acquire a velocity sufficient

¹ J. S. Townsend, "The Theory of Ionization of Gases by Collision."

to produce ionisation by collision. A few ions are always present, for no gas is a perfect insulator. C. T. R. Wilson¹ found that at the atmospheric pressure, the rate of leakage of charge from a body in an enclosed space is $10^{-8}\nu$ electrostatic units per second, where ν is the volume in cubic centimetres of the enclosure. When the electric intensity reaches such a value that ionisation by collision begins, the number of ions present will rapidly increase, and it is found that a very much smaller electric intensity is required to maintain the current in the gas than to start it.

Prof. Townsend² found in one case, with air at 4.31 mm. pressure, between parallel electrodes 8 mm. apart, that the gas acted as an insulator when the difference of potential between the plates was 601 volts, but on increasing this to 603 volts a current of 0.0052 ampere passed between the electrodes, the difference of potential between which dropped to 350 volts.

The lag in the establishment of the spark that has been noticed by many observers is also accounted for, the gas acting as insulator, for a very short time, to an electromotive force which would produce the discharge if continuously applied. The setting up of the steady condition of ionisation requires time, since the initial number of ions present in the gas is exceedingly small.

Ionisation by Hot Bodies.—It has been known for a long time that an electric charge would leak much more rapidly from a hot body than from a cold one, and that the rate of leak is different for charges of opposite signs. The phenomenon was investigated by Elster and Geitel.³ The wire A (Fig. 417) is heated by means of a current, and the plate B near it is connected to an electrometer. The charge received by the plate depends upon the gas present, its pressure, and also upon the nature of the wire. The temperature of the wire, however, is the most important factor in determining the electrification of the plate. With oxygen at atmospheric pressure, and the wire at a dull red heat, the plate receives a positive charge, its potential being 2 or 3 volts. With rise of temperature the charge increases, reaches a maximum, and then falls to a very low value. Reduction in the pressure to that of a high vacuum reduces the charge, and even reverses its sign at very low pressures. With hydrogen the charge on the plate is negative at all pressures. The effects are exceedingly complicated, as the wire gives out occluded gas and may even give off pieces of its own substance.

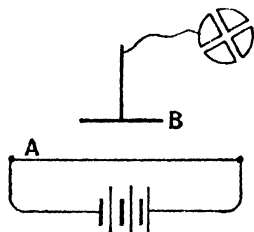

FIG. 417.

¹ C. T. R. Wilson, *Proc. Roy. Soc.*, **68**, p. 151. 1901.

² J. S. Townsend, *Phil. Mag.*, **8**, p. 738. 1904.

³ J. Elster and H. Geitel, *Wied. Ann.*, 1882, 1883, 1884, 1885, 1887, and 1889

The nature of the gas in the neighbourhood of a hot wire was investigated by Prof. J. A. McClelland,¹ by drawing off the gas. At the temperature of dull red appearance, the gases would discharge a body having a negative, but not one having a positive charge, but at higher temperatures both signs of electrification were discharged. Also the current which the gas would carry exhibited the phenomenon of saturation and behaved like an ionised gas. The current — p.d. curve is of the nature of that given in Fig. 414.

Sir J. J. Thomson,² using a wire heated by means of a current and surrounded by a cylindrical conductor, the whole being sealed in a tube, found that at a pressure of 0.001 mm. of mercury, a current could easily be made to pass by an electromotive force of about 10 volts in such a direction that the negative charge goes from the hot wire to the cylinder, but not in the reverse direction. This indicates that the current is carried by negative ions emitted by the hot wire. In the case of an incandescent filament, much greater currents could be obtained than with a platinum wire, probably due to the fact that the carbon may be raised to a much higher temperature.

More recently Harker and Kaye³ have obtained currents as great as 10 amperes by means of an electromotive force of 8 volts between carbon rods at a temperature approaching 3000° C., the pressure being atmospheric. Between carbon rods at different temperatures they have obtained currents on account of the different rates of emission of ions.

Edison Effect.—The Edison effect, made use of by Prof. Fleming in his oscillation valve (p. 442), is another result of the same phenomenon. If a metallic plate, D, be situated between the limbs of the filament of an incandescent lamp, then on connecting the positive end of the filament through a galvanometer to D (Fig. 418) a current will be observed to flow in the galvanometer, but none when D is connected to the negative limb B. We should expect that the negative ions emitted by the incandescent carbon would be more vigorously repelled from the negative limb, and hence on meeting D would lower its potential. The difference of potential between A and D is then much greater than that between B and D.

It has been shown by Sir J. J. Thomson,⁴ by the method of finding the effect of a magnetic field upon the rate of leakage (p. 475), that the negative ions emitted by a hot wire have the same value of $\frac{m}{e}$ as the corpuscles in the kathode rays, thus establishing their identity with these bodies.

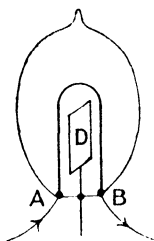

FIG 418

¹ J. A. McClelland, *Proc. Camb. Phil. Soc.*, 10, p. 201. 1900.

² J. J. Thomson, "Conduction of Electricity through Gases."

³ J. A. Harker and G. W. C. Kaye, *Proc. Roy. Soc. A.*, 86, p. 379. 1912.

⁴ J. J. Thomson, *Natl. Mag.*, 48, p. 547. 1899.

The emission of positive ions at temperatures below that required for the emission of negative ions, has already been noticed, and their ratio $\frac{m}{e}$ was also found by observing the strength of magnetic field required to affect the leakage of a charge to a neighbouring conductor, and it was found that there were two sets of positive ions taking part in the leak, one set having a mass equal to that of the atom of the metal and the other that of the gas. In some cases there are bodies of greater mass still, taking part in the production of leakage. These are probably metallic dust.

Amplifying and Rectifying Valves.—The principle of the Fleming valve (p. 442) has been developed in recent years into a method for magnifying or amplifying extremely feeble electrical oscillations, by employing a vacuum bulb having three electrodes. This amplification has greatly extended the range of radio-telegraphy and has also many other applications. There are several forms of the valve, but they are alike in having a filament of tungsten, F (Fig. 419), heated by a current from a battery of two cells BD, a gauze or spiral wire G, and a metal sheath P which is outside the gauze. If the bulb is very highly exhausted no current can flow from the filament to the gauze or grid G, through the

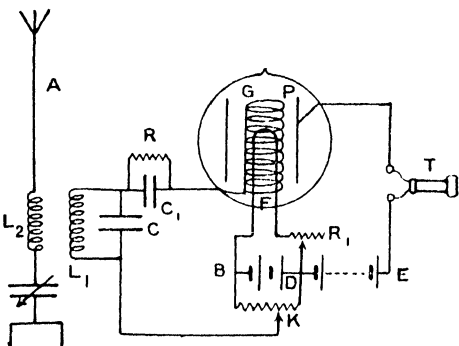

FIG. 419.

valve, but current can flow in the reverse direction. The reason is that the hot filament emits electrons which travel from the filament to the grid when the electric field is directed from the grid to the filament, but when the field is reversed the electrons remain on the filament. The circuit PTEDF contains the battery DE of 100 to 150 volts, which tends to drive a current through the valve from P to F, making P anode. The resistance of the valve between P and F is controlled greatly by the electric field between G and F, that is, by the potential of the grid with respect to the filament. For when G is negative with respect to F no electrons leave F, and the resistance of the valve is practically infinite. But if G is positive with respect to F, electrons pass freely from F and may pass in quantity through the interspaces of the grid, when there is an electric field from P to F. The current produced in the valve between the anode P and the filament depends, therefore, upon the p.d. between the grid and filament,

and in order to understand the action of the valve, it is desirable to measure the grid current and anode current for various values of the grid-filament p.d. This may be done by replacing the telephone T by a micro-ammeter and placing a voltmeter between B and G, and a micro-ammeter in the circuit BCG. On varying the grid potential by varying the position of the potentiometer contact K, the three quantities are observed, and their values may be plotted. The curve obtained is called the static characteristic of the valve. The characteristic varies with different kinds

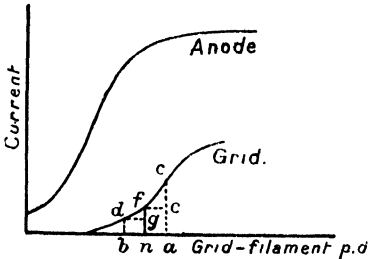

FIG. 420.

of valve, but it is always of the same type in the case of hard valves (Fig. 420), or valves where the vacuum is so high that there is no appreciable effect due to contained gas. The anode current is much greater than the grid current, and the latter is drawn to a larger scale than the former. Consequently the valve acts as an amplifier of small oscillatory currents occurring in the circuit L_1C (Fig. 419).

In order to use the valve as a rectifier in radio-telegraphy, many devices are used. In the method considered here K is connected to D and a very small condenser C_1 is placed in the grid circuit, the condenser having a high resistance R, of the order of a megohm, in parallel with it. When there are no oscillations in the circuit L_1C , the grid potential acquires a steady value n (Fig. 420), a small current, nf , flowing from grid to filament. When electro-magnetic waves fall upon the aerial, oscillations of potential, na and nb , are produced in the grid circuit, and owing to the curvature of the grid current curve the increase of current ec is greater than the decrease fg , as in the case of the crystal detector (p. 442). This means that the stream of electrons from the filament to the grid is increased, while a train of waves is arriving, and the potential of the grid is lowered. The anode current therefore suffers a decrease, but recovers its value corresponding to the point n when the waves cease. This change of mean current in the anode circuit causes a sound in the telephone. In this way the waves which are of too high a frequency to affect the telephone, or to be audible if they did, are enabled to produce signals which can be heard.

These three-electrode valves have also been used for generating continuous electro-magnetic waves in a similar manner to the electric arc (p. 444). On coupling the grid and anode circuits by means of a mutual inductance or by means of a capacity, and applying the battery to the anode circuit, it is found that, with suitable grid current, oscillations occur in the anode circuit. One method of carrying this out is shown in Fig. 421, in which the inductance L_1 is placed in the

grid circuit and the oscillatory circuit LC is placed between P and E. The theory of production of the oscillations is not simple, but it may be noted that for them to occur, the mutual inductance L_1L must be negative, so that when the current in L_1 first rises the E.M.F. in L raises the potential of G above that of F. The action of the valve is therefore to increase the anode current on rising and to diminish it when falling, and thus to compensate for the damping of the oscillations that would occur in LC were there no valve present (p. 334). This is borne out by the fact that the oscillations can only be produced through a limited range occurring at the steepest part of the anode characteristic.

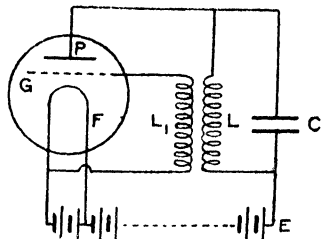

FIG. 421.

There are many types of three-electrode valve, including the audion and the French valve, both of which are hard valves. They may be used in groups to increase the amplification, and the variety of arrangement is very great.

Ionisation in Flames.—That the phenomenon of ionisation takes place in ordinary flames may be shown in several ways. For example, if two platinum wires are placed in a bunsen-burner flame but not touching each other, a current may be made to pass between them by connecting them to the terminals of a cell, and a sensitive galvanometer in the circuit will indicate a feeble current. If a bead of a sodium or potassium salt be placed in the flame below the platinum wires, the conductivity of the flame is enormously increased, owing to the presence of ions liberated from the substance at high temperature.

The old experiment of discharging an electrified glass or ebonite surface by passing a flame over it illustrates the presence of the ions, since those of opposite sign to the charge on the plate are attracted to it and neutralise the charge.

The increase in conductivity of a flame due to the introduction into it of a volatilisable metallic salt has been measured by several experimenters. Arrhenius¹ supplied the salt to the flame by spraying a solution into the gas which feeds the flame, and the concentration of the salt in the flame was determined by observing the rate at which a bead disappears which gives the same illumination as the spray. The conductivity in the flame is found by observing the current in a circuit which includes part of the flame, and subtracting the current produced when there is no salt employed. The (electromotive force)-current curve exhibits the same characteristics as that for an ionised gas, but the straight portion is not quite horizontal, showing that complete saturation is not attained. Using the same method, Prof. H. A. Wilson² found that for the salts of cesium, rubidium, potassium,

¹ S. Arrhenius, *Wied. Ann.*, **42**, p. 18. 1891.

² H. A. Wilson, *Phil. Trans.*, A., **192**, p. 499. 1899.

sodium, lithium, and hydrogen, the conductivity is in the order of the atomic weights.

Prof. Wilson also found the velocity of the ions in a given electrical field by arranging two electrodes in the flame, one above the other, with the bead of salt between them, and determining the field necessary to drive the ions downwards in opposition to their velocity due to the upward motion of the flame gases (Fig. 422). With the upper electrode positive, the presence of the bead will not affect the current unless the field is sufficiently strong to drive the positive ions downward with a velocity just greater than the velocity with which they are carried upwards by the flame. In this way the velocity of

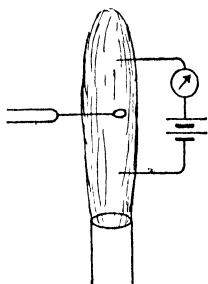

FIG. 422.

the negative ions for a potential gradient of one volt per cm. in a flame whose temperature is about 2000°C . was found to be about 1000 cm. per second. The velocities of the positive ions of the salts of caesium, rubidium, potassium, sodium, and lithium were all about 62 cm. per sec.

Using a stream of hot air at about 1000°C ., the velocities were respectively 26 cm. per sec. for the negative, and 7.2 cm. per sec. for the positive ions, whereas for barium, strontium, and calcium it is 3.8 cm. per sec. for the positive ions. These low velocities appear to indicate that the ions become loaded with neutral atoms,

and the equality in velocities for the ions of the different atoms indicates that the size of these groups depends upon the charge on the ion, being larger in the case of the divalent ions than in the case of those which are monovalent.

CHAPTER XVI

RADIOACTIVITY

Becquerel Rays.—While investigating the relation between phosphorescence and the production of rays able to produce a photographic effect after transmission through opaque material, Becquerel¹ found, that in the case of the double sulphate of uranium and potassium, a photographic effect was produced even when the salt had not been exposed to sunlight. In fact, it was subsequently found that the effect is the same after keeping the salt in a light-tight lead box for several years, or on dissolving it in water in the dark and recrystallising it, still in the dark ; and further, that the photographic effect is produced by the uranium, whatever the nature of the chemical combination in which it exists.

The photographic effect is of a similar nature to that produced by the Röntgen rays, but is very much feebler than the effect produced by an ordinary X-ray tube. Whereas an exposure of a few minutes to Röntgen rays will produce a considerable photographic effect on an ordinary sensitive plate, several days' exposure is necessary in the case of uranium.

Other substances have been found to emit rays similar to those emitted by uranium, and the name of Becquerel rays has been given to them ; but, owing to the complexity of these rays, other names for their several constituents have replaced the original name for general use.

Ionisation.—The Becquerel rays possess the power of rendering the gas through which they pass conducting. Thus if the uranium salt be spread upon the plate A (Fig. 423) parallel to the plate B, which latter is in connection with the gold leaf of an electroscope, the charge given to the electroscope will leak away, owing to the gas between A and B being a conductor, and the rate of leak is a measure of the ionising power of the substance spread upon A. This form of the electroscope was used by M. and Mme. Curie in many of their investigations.

Another extremely useful form of electroscope for the measurement of the ionisation produced by radioactive substances is due to C. T. R.

¹ H. Becquerel, *Comptes Rendus*, 122, p. 501. 1896.

Wilson. The rigid support B has a thin aluminium leaf A attached to it. When charged the leaf stands as shown in Fig. 424, its motion, as observed by a telescope with a transparent scale in the eyepiece, or by comparison with the reflected image of a linear scale, is a measure of the conductivity of the gas within the cubical brass vessel. In order to obtain good insulation, B ends in a metal block, C,

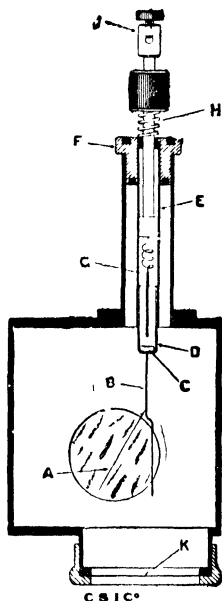

FIG. 424.

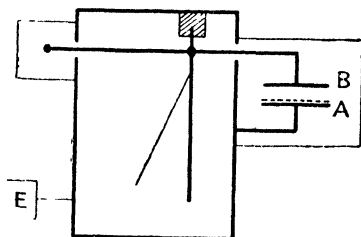

FIG. 423.

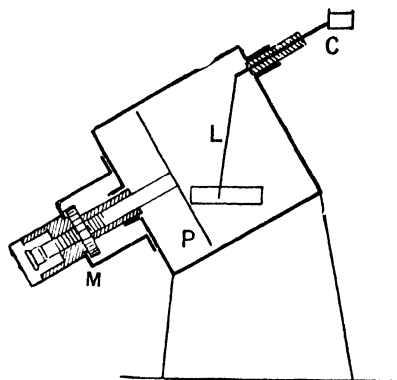

FIG. 425.

carried by a tube of fused quartz, D, fixed by shellac to the brass tube E. This is supported by an ebonite bush, F, in the upper and lower faces of which annular slots are turned and filled with sulphur to prevent leakage over the faces. In order to charge the leaf, the brass rod which carries the terminal J at its upper end and the light rod G at its lower end, is depressed until G touches C, and the charge is then given to the leaf. On releasing the rod, the spring H raises it, and B and A are again insulated. The lower window K is covered with a layer of thin tissue paper to exclude draughts, and the radio-

active material is placed below it, the rays which produce ionisation thus entering the chamber of the electroscop.

A more sensitive arrangement has also been devised by C. T. R. Wilson,¹ in which the gold leaf L (Fig. 425) is attracted by the plate P, which is charged to a constant potential of about 200 volts. The best form of the instrument, and the conditions for satisfactory working, have been found by G. W. C. Kaye.² The gold leaf is first connected to the brass case, and the instrument tilted until the leaf is in the field of the observing microscope. The sensitiveness of the instrument can be altered by varying its tilt, and also the distance of the earthed plate P from the gold leaf, by means of the micrometer screw M, the maximum sensitiveness occurring when the leaf approaches instability owing to its proximity to the plate. The leaf is then connected by means of the conductor C to the body whose rate of change of potential it is required to know. With the plate at potential 207 volts, and the leaf inclined at 30°, a travel of about 5½ mm. was found for a variation in potential of the leaf of 1 volt.

The quadrant electrometer also is extensively used for the measurement of the current in ionised gases. The radioactive material is spread upon the plate A (Fig. 426), the parallel plate B being connected to one pair of quadrants of the electrometer. One end of a battery is connected to A, the other end being earthed. To begin with, the plate B is also connected to earth by means of the key K. This is opened at a known instant, and the electrometer deflections observed after equal intervals of time. Then, as on p. 485, if c is the capacity of the electrometer and the conductors connected with it, and θ the deflection at any time t —

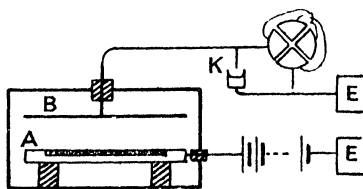

FIG. 426.

$$i = ck \cdot \frac{d\theta}{dt}$$

where k is the difference of potential between the quadrants for unit deflection.

By varying the electromotive force of the battery used to produce the current, the relation between potential difference and current can be obtained. This relation is similar to that obtained in the case of the conductivity produced by Röntgen rays; that is, the current increases rapidly with the difference of potential for small values but soon ceases to increase, the greatest value being the saturation current (Fig. 414), and this depends upon the pressure, potential gradient, and

¹ C. T. R. Wilson, *Camb. Phil. Soc. Proc.*, **12**, p. 135. 1903.

² G. W. C. Kaye, *Proc. Phys. Soc.*, **23**, p. 209. 1911.

the distance apart of the plates and the amount of radioactive material present. The curves, Fig. 427, given by Prof. Rutherford show the relative increase in the current with potential gradient for a thin layer of uranium oxide upon one of a pair of parallel plates, when the distance between the plates is 0.5 cm. and 2.5 cms. respectively.

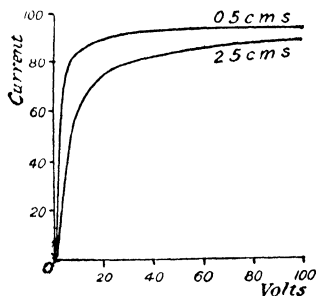

FIG. 427.

a week, it is found when the plate is developed that the woven pattern of the mantle is seen upon it.

Radium.—On examining a number of minerals for the emission of Becquerel rays, or for radioactivity, as it is now called, Mme. Curie found, using the leakage method, certain specimens of pitchblende to be more radioactive than uranium. The mineral pitchblende contains barium, and on separating out this substance by precipitation as the carbonate, it is found that the radioactivity of the precipitate is very great. On converting into the chloride and employing the method of fractional crystallisation, the parts that separated out first were found to be, as the process was repeated, more and more radioactive. M. and Mme. Curie in this way separated from the barium another substance of enormous radioactivity which they called *radium*. The process of separation of the radium chloride from the ore is exceedingly tedious, a ton of ore yielding only a few decigrammes of radium.

Polonium.—One of the processes in the separation of the metals in the pitchblende consists in the precipitation of the lead, antimony bismuth group by means of sulphuretted hydrogen. The deposit produced is found to be radioactive, and a further separation showed that the radioactivity is associated with the bismuth. By fractional precipitation by diluting a solution of the nitrate, a new radioactive element which Mme. Curie named *polonium* was obtained; whether it has been completely separated from bismuth is doubtful. The more readily precipitated part is the more active. The activity of polonium is many times that of uranium. It is now known that polonium is identical with RaF, one of the products of radium (p. 522).

Actinium.—Another radioactive material has been obtained by Debierne² from pitchblende in association with the iron group, an

¹ G. Schmidt, *Wied. Ann.*, **65**, p. 141. 1898.

² A. Debierne, *Comptes Rendus*, **130**, p. 906. 1900.

with difficulty separated out. It has been named *actinium*, and has an activity comparable with that of radium.

Absorption.— α , β , and γ Rays. If a layer of radium bromide be placed in the tray (Fig. 423), and the rate of collapse of the leaves observed, it will be found on covering the radium with a sheet of tinfoil, that the rate of collapse of the leaves is very much less than without the tinfoil. The ionisation may be reduced to one-tenth by a sheet of ordinary foil. If the rays emitted by the radium are all of one kind, a second layer of tinfoil would produce a further proportionate reduction, and the radiation transmitted would be one-hundredth of the original amount. This, however, is not found to be the case; the reduction produced by the second layer of foil is very small. Hence, there are at least two constituents in the original rays, one readily absorbable, and the other much less absorbable. Rutherford named the more absorbable rays the α rays and the more penetrable the β rays.

On continuing the above experiment with more layers of tinfoil, it will be found that after a time the additional layers again produce less effect; or if sheets of lead be used, it is found that a sheet 2 mm. thick produces a large reduction in the ionisation, but a second sheet of the same thickness does not produce nearly so great a reduction as the first. This is due to the fact that in addition to the α and β rays, others of very much greater penetrating power are present, which Rutherford called the γ rays. The following table is given by him:—

Rays.	Thickness of aluminum which reduces ionisation to one-half	Relative penetrating power.
α	0.0005 cm.	1
β	0.05 cm.	100
γ	8 cms.	10,000

The relative intensities of emission of the three kinds of rays cannot satisfactorily be determined, but obvious variations exist between the radiations from different substances. Thus the radiation from radium and polonium consists largely of α rays, and these take part in the photographic as well as the electrical effects, while in the case of uranium and thorium they are comparatively feeble. It is a notable fact that the β and γ rays generally occur together, their existence being independent of the presence of the α rays.

α Rays.—The ionisation produced by the rays emitted by radium is chiefly due to the α rays, owing to the great quantity emitted; the ionisation due to the β and γ rays has been noted above.

Another property of the α rays is their power of producing fluorescence; a diamond exhibits a blue fluorescence when brought near a small quantity of radium bromide. Other substances, such as

zinc sulphide, also are caused to fluoresce by the α rays, and hence the spintharoscope of Sir Wm. Crookes, in which a speck of radium bromide is placed behind a screen on which is spread a thin layer of zinc sulphide, the whole being mounted in a brass tube, at the other end of which is a lens, placed so that an enlarged image of the screen can be seen. It is then observed that the fluorescence is not a uniform glow, but has the appearance of a shower of sparks, no two following each other in the same place. That the fluorescence is due to the α and not the β or γ rays may be proved by interposing a thin sheet of mica between the radium and the screen, the fluorescence then ceasing. The cause of the luminosity is probably the rupturing of the crystals of zinc sulphide when struck by an α ray particle, as a similar luminosity may be produced by fracturing the crystals by mechanical means.

Deflection of α Rays by Magnetic Field.—The α rays can only with difficulty be deflected by a magnetic field, but the fact that they can

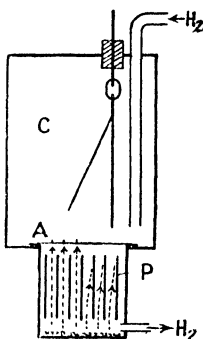

FIG. 428.

be deflected at all shows that they consist of moving charged particles, and further, the direction of the deflection proves them to be positively charged. Owing to the small amount of deflection, the method of p. 472 is not applicable. Prof. Rutherford¹ measured the deviation in a magnetic field by the method illustrated in Fig. 428. The radium is spread in a thin layer underneath a system of parallel plates, P, placed vertically and at known distance apart. With no magnetic field, the α rays pass vertically upwards between the plates, and passing through the extremely thin aluminium window A, enter the electroscopical chamber C and cause a collapse of the leaves at a rate which can be measured. On applying a magnetic field which is horizontal and parallel

to the plane of the plate P, the α rays are deviated in such a way that they are driven against the plates, and will not then reach the chamber C. In the left-hand part of Fig. 428 the α rays are shown passing upwards as they do without the magnetic field being present, and those shown on the right hand are being deviated by the field. The field which just cuts off the rays from the chamber C is found, and then the dimensions of the spaces being known, Hv (see p. 472) is known. During the experiment a stream of gas passes downwards through the apparatus to carry away the emanation as it is formed (p. 512).

The electrostatic deviation of the α rays was found by means of an experiment similar to the above, but with alternate plates connected together, the two sets being maintained at different potentials. The electrical field between the plates caused the α rays

¹ E. Rutherford, *Phil. Mag.*, 5, p. 177. 1908.

to be driven against one set of plates as before, with consequent reduction in the rate of ionisation in C.

By reasoning similar to that on p. 472 it was found that for the α rays from radium—

$$v = 2.5 \times 10^9 \text{ cms. per sec.}$$

and,
$$\frac{e}{m} = 6 \times 10^8,$$

which is a quantity of the order of half that for the hydrogen ion in electrolysis and the positive ion in the canal rays. By arranging that the plates P have a projecting ridge on one side at the upper edges in some of the experiments, so that the rays when deflected to this side were not allowed to pass, it was shown that the charges of the α particles are of positive sign.

Absorption of α Rays.—Measurements of the absorption of α rays have brought to light the interesting fact that the power of producing ionisation possessed by them does not diminish gradually as their path in the absorbing medium increases; it does not diminish at all up to a certain range, and then ceases abruptly. This discovery was made

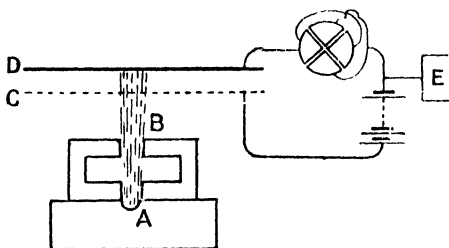

FIG. 429.

by Bragg and Kleeman,¹ who used a small quantity of radioactive substance at A (Fig. 429), and limited the α rays to a narrow beam falling upon the air situated between the gauze C and the metallic plate D. These are kept at constant distance apart, their distance from A being variable. The ionisation at any given distance is then measured by the rate of leak of charge between C and D when a constant difference of potential is maintained between them. The "range" of the α rays in air, that is, the distance travelled before their ionising power ceases, is then found by varying the distance of CD from A, until the rate of leak of charge is independent of the presence of the radioactive material.

The layer of radioactive material at A must be very thin, or some of the α rays will on emergence have already passed through a layer of the material, and their "range" have been reduced, so that the

¹ W. H. Bragg and R. Kleeman, *Phil. Mag.*, 10, p. 318. 1905.

beam is no longer homogeneous and the ceasing of the ionisation will not take place abruptly. The "range" for the α rays produced by radium is in air about $7\frac{1}{2}$ cms., and it is important to notice that the phosphorescent and photographic effect of the rays ceases at the same distance as their power of producing ionisation. Rutherford, by the method of magnetic deflection, found that the ionisation ceases when the velocity of the α particles falls below 1.12×10^9 cms. per second. Hence α rays with velocity less than this would be undetectable except for their charge, and thus many substances may be emitting α rays whose radioactivity is at present unsuspected.

By interposing layers of different materials in the path of the α rays, their effect upon the "range" was found, and the results showed that the stopping power of any substance is proportional to the square root of its molecular weight.

β Rays.—The fluorescence produced by the β and γ rays is brilliant in the case of barium platinocyanide, which is therefore a convenient substance for studying these rays. Many other substances exhibit fluorescence, the colour varying with the substance.

The absorption of the β rays by ordinary matter has been described on p. 501. They are very much more deviated in a magnetic field than the α rays, and in a direction which indicates that they are negatively charged particles. The beam of β rays from a specimen of radium bromide is not deviated uniformly in a magnetic field, but is spread out, indicating that the beam itself consists of particles in different conditions. Becquerel has made measurements upon the magnetic deviations in a number of cases, but the greatest interest attaches to some measurements of Kaufmann,¹ in which the velocity of the rays and the ratio $\frac{e}{m}$ are obtained by causing the displacement produced by a magnetic field, and one by an electrostatic field, to take place simultaneously, but in directions at right angles to each other. A thin beam of β rays falls normally upon the photographic plate, giving rise to a small patch when there is no magnetic or electrostatic field. The magnetic field alone, being at right angles to the rays, would spread them out into a "spectrum" in a line at right angles to the direction of the field. The electrostatic field is in the same direction as the magnetic field, but since it produces a deflection in its own direction, this is perpendicular to that produced by the magnetic field. The method is similar to that of crossed spectra used in optics for studying anomalous dispersion. The simultaneous displacements of the beam being at right angles to each other, every point of the photographic plate which is "exposed" corresponds to a pair of values of v and $\frac{e}{m}$, and the various points lie upon a curve. In this way it was found that the ions have velocities much greater than those in the

¹ Kaufmann, *Phys. Zeitscher.*, 4, No. 1b, 1902.

kathode rays, but that the mass varies with the velocity, increasing as the velocity approaches the velocity of light, as the following table shows :—

Velocity.	$\frac{e}{m}$
2.36×10^{10} cm. per sec.	1.31×10^7
2.48 " " "	1.17 "
2.59 " " "	0.97 "
2.72 " " "	0.77 "
2.85 " " "	0.63 "

The diminution of $\frac{e}{m}$, due to the increase in m when the velocity increases, is a consequence of the electromagnetic theory, as we shall see on p. 527.

We may follow the method employed by considering Fig. 430 (i) to be the plan of the photographic plate, the beam of rays from the observer falling at O, in the absence of the electric and magnetic fields. If OY be the direction of these fields, the displacement due to the magnetic field is parallel to OX, the path of an electron being seen in elevation at (ii). From the equation on p. 472, $Hev = \frac{mv^2}{r}$, and the curve Px has therefore radius $r = \frac{m}{e} \cdot \frac{v}{H}$. From the geometry of the figure, since x is small, we have $x \cdot 2r = d^2$,

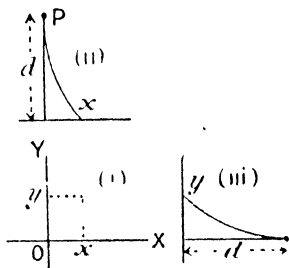

FIG. 430.

$$\therefore x = \frac{d^2}{2} \cdot \frac{e}{m} \cdot \frac{H}{v}.$$

Similarly the path in the electric field is shown in the side elevation (iii). The velocity normal to the plate is v , and the force on each electron due to the field is Ee , and the path Py is therefore similar to that of a body projected in a given direction and subjected to a constant force at right angles to this direction. The curve Py is therefore a parabola, and if t be the time taken by the electron to pass from P to the plate, $\frac{d}{v} = t$. But $y = \frac{1}{2}at^2$, where a is the acceleration due to the electric field and is equal to $\frac{Ee}{m}$,

$$\begin{aligned} \therefore y &= \frac{1}{2} \frac{Ee}{m} t^2, \\ \text{and,} \quad t^2 &= \frac{d^2}{v^2}, \\ \therefore y \frac{2m}{Ee} &= \frac{d^2}{v^2} \\ y &= \frac{e}{m} \cdot \frac{1}{v^2} \cdot \frac{Ed^2}{2}. \end{aligned}$$

Combining the values for x and y , we have—

$$\frac{x}{y} = v \cdot \frac{H}{E} \quad \text{and,} \quad \frac{x^2}{y} = \frac{e}{m} \cdot \frac{d^2}{2} \cdot \frac{H^2}{E}.$$

Thus v and e/m can be found. It will be noticed that all particles having the same velocity will lie on the straight line $x/y = \text{constant}$, and those having the same value of e/m will lie upon the parabola $x^2/y = \text{constant}$.

It is assumed in the above calculation that the fields are uniform and extend up to the plate. This is not the case in practice, but the corrections on this account are of a purely geometrical nature.

Charge carried by β Rays.—That the β rays carry a negative charge has been shown by many experimenters; notably by M. and Mme. Curie,¹ who allowed the rays to fall on a plate connected to an electrometer, and observed the changing deflection. The chief difficulty arises from the fact that the rays render the air surrounding the body conducting, and they got over this difficulty by embedding

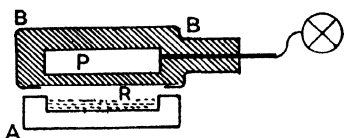

FIG. 431.

the conductor P (Fig. 431), which absorbs the rays, in a non-conducting material situated inside an earthed conducting sheath BB. The insulating material was in some cases ebonite, and in others paraffin, but it was always found that the presence of the radium salt R caused a negative charge to accumulate progressively upon P.

Since the radium loses negative electricity on account of the β rays more readily than it does positive electricity carried away by the α rays, the β rays being the more penetrating and escaping more readily than the α rays, it would appear that radium enclosed in a non-conducting vessel would acquire a continually increasing positive charge. Prof. Strutt² constructed an interesting arrangement to exhibit this effect. The radium salt is contained in a tube A (Fig. 432) suspended in a vacuum tube, and therefore insulated from its surroundings.

¹ M. and Mme. Curie, *Comptes Rendus*, **130**, p. 647. 1900.

² R. J. Strutt, *Phil. Mag.*, **6**, p. 588. 1903.

Attached to **A** is a pair of gold leaves. The walls of **A** are of such a thickness that the β rays can penetrate them and escape, but the α rays cannot. As **A** acquires a positive charge the gold leaves gradually diverge, until on touching the sides of the tube they are discharged, the process then starting afresh. Since the periodic time for the process is independent of external conditions, it is practically constant, and may be used to mark intervals of time. Such an apparatus would continue to act as long as the emission of β rays lasts, and this in the case of radium is certainly measured in hundreds of years.

γ Rays.—These rays differ greatly from the two other kinds. They are non-deviable in a magnetic field, and do not carry an electric charge. Their chief characteristics are their great penetrating power and their ability to produce ionisation. Hence, the resemblance between the γ rays and the Rontgen rays from a "hard" vacuum tube is very strong.

If they are in character similar to X rays and consist of a thin electromagnetic pulse, we should expect that they originate at the moment of expulsion of one of the negative corpuscles constituting the β rays from the atom, since a pulse of this kind would arise on starting or stopping an electric charge (p. 531). It must not be forgotten, however, that β rays moving with a velocity very nearly that of light would have similar properties to those possessed by the γ rays, and also that uncharged or neutral bodies projected from the atom with these high velocities would also have the property of being undeviated in a magnetic field, and might produce the observed ionisation effects. Both these explanations have been put forward, but the above, that is, the similarity to the X rays, is the one generally held. γ rays produce a secondary radiation when falling on matter.

In Fig. 433 is shown a diagram illustrating the deviability of α , β , and γ rays in a magnetic field, first given by Mme. Curie. The γ rays are undeviated, while the deviation of the α rays to one side indicates their positive charge, the negative charge of the β rays being indicated by their deviation to the other side. The relative dispersions are also evident.

δ Rays.—In addition to the α , β , and γ rays, slowly moving negative corpuscles have been detected by Sir J. J. Thomson¹ by means of the charge they carry. They would thus be similar in character to the β rays, but, owing to their lower velocity, they do not produce ionisation. Measurements of their velocity have shown this to be 3.25×10^8 cms.

¹ J. J. Thomson, *Camb. Phil. Soc. Proc.*, 13, p. 49. 1905.

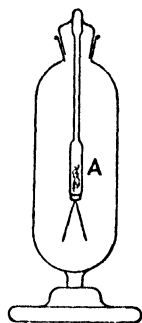

FIG. 432.

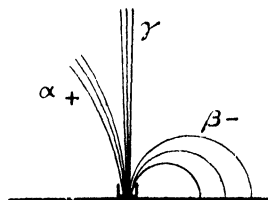

FIG. 433.

per second, whereas the limiting velocity for the production of ionisation has been estimated to be 3.6×10^8 cms. per second.

The Curie.—The standard of radioactivity is the quantity of radium emanation in equilibrium with 1 gram of radium and is called the curie. It has a volume of 0.59 cubic mm. at standard temperature and pressure.

Radioactive Changes.—The emission of Becquerel rays by a radioactive substance is accompanied by a change or series of changes in the nature of the substance, changes both in its physical and its chemical properties, so profound and complex that their study has enormously increased our knowledge of the constitution of matter itself. The case of radium is typical. If a quantity of a radium bromide be heated or dissolved in water, a new substance, gaseous in form, is separated from it, and immediately after the separation this new substance possesses very high radioactivity, while that of the radium is correspondingly reduced. If these two be examined after the lapse of a few days, it will be found that the activity of the radium has increased, while that of the other substance, known as its emanation, has fallen. The decay of activity of the emanation follows an exponential law, that is, the rate of decay is proportional to the activity; and at the same time the activity of the radium has increased according to a similar law. After a sufficiently long interval, the activity of the radium is completely restored, while that of the emanation, in fact the emanation itself, has entirely disappeared.

Uranium X.—Sir William Crookes¹ precipitated uranium from solution by means of ammonium carbonate, and redissolved the uranium by excess of the carbonate. A slight precipitate remained, which he found was several hundred times more photographically active than the original uranium. This substance he named uranium X. The photographic activity of Becquerel rays is chiefly due to the presence of β rays; hence the β rays are now emitted by the Ur X, and no longer by the uranium. Had the examination been by means of the power of producing ionisation, which is due to the α rays, it would have been found that the uranium still possesses this power, but not the Ur X.

It was subsequently shown by Becquerel that after the lapse of a year Ur X has completely lost its activity, while the uranium has regained its original condition.

Thorium X.—Radioactive processes are now known as those in which a chemically new substance is formed from some other, the change being generally accompanied with the emission of rays α , β , or γ . The new substance generally decays at a rate represented by a logarithmic curve, and its production goes on at a constant rate within the parent material. Thus, on robbing the material of the new substance stored in it, its radioactivity is reduced at first by exactly the amount of that due to this stored material, but on being then allowed to

¹ W. Crookes, *Proc. Roy. Soc.*, 66, p. 409. 1900.

remain undisturbed, its radiation will increase owing to the production of new material, until the loss by decay is balanced by the further production, in which case a condition of equilibrium is reached.

This explanation was put forward by Rutherford and Soddy¹ to account for the changes occurring in thorium, and it has subsequently been found that a similar explanation may be given to all radioactive changes, although the new substance formed may be solid, liquid, or gas, its rate of decay may be rapid or slow, and the change may be accompanied by radiation or may be rayless. They precipitated the thorium from solution by means of ammonia, and found that the solution, which

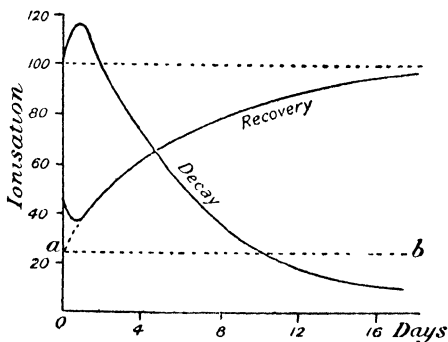

FIG. 434.

is free from thorium, has the greater part of the activity; and on evaporating to dryness and driving off the ammonium salts, a solid residue is obtained which in proportion to its weight is several thousand times as active as the original thorium. This substance was named thorium X, or Th X. After the lapse of a month the Th X had lost its activity, while the Th had completely recovered. On measuring the activity of the Th and Th X at known intervals after their separation, the curves of Fig. 434 were obtained. It will be seen that, apart from slight irregularities at the start, the Th X loses its activity exponentially, that is, according to the law $\frac{A_T}{A_0} = \epsilon^{-\lambda T}$, where A_0 is the activity at the start, and A_T that after time T , λ being a constant; and, moreover, the Th, which has only about 25 per cent. of its activity remaining on removal of the Th X, regains its activity at a rate equal to the rate of loss of activity of the Th X. Hence, for the activity A_T recovered in time T ,

$$\frac{A_T}{A_0} = 1 - \epsilon^{-\lambda T},$$

¹ E. Rutherford and F. Soddy, *Phil. Mag.*, 4, p. 370. 1902.

where A_0 is the activity recovered after infinite time. If the curve of recovery in Fig. 434 be measured from the dotted line ab , its equation will be found to fit approximately the curve. The activity of the Th X falls to half its value in about four days, and in the same time the Th performs half its recovery.

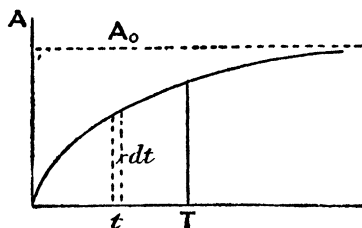

FIG. 435.

Let the whole mass of the thorium present produce a number q_0 of Th X atoms per unit time, and the rate of emission of activity by the Th X atom be K . Then, in order to find the total activity due to the Th X stored in the thorium after time T from separation, consider an interval of time dt after t seconds from the separation (Fig. 435). The number of Th X atoms produced in time dt is $q_0 dt$, and this has activity $Kq_0 dt$, which in the remaining interval $(T - t)$ decays in the ratio $e^{-\lambda(T-t)}$. Thus the activity at time T due to the Th X produced in the given interval dt is $Kq_0 \cdot dt \cdot e^{-\lambda(T-t)}$, and calling this dA we have—

$$dA = Kq_0 \cdot e^{-\lambda(T-t)} dt,$$

and for the activity A_T of the whole of the Th X produced in the interval from 0 to T ,

$$\begin{aligned} A_T &= \int_0^T dA = \int_0^T Kq_0 e^{-\lambda(T-t)} dt \\ &= \frac{Kq_0}{\lambda} \left[e^{-\lambda(T-t)} \right]_0^T \\ &= \frac{Kq_0}{\lambda} (1 - e^{-\lambda T}) \end{aligned}$$

But when $T = \infty$, $A_T = A_0$,

$$\therefore A_0 = \frac{Kq_0}{\lambda},$$

or,

$$\frac{A_T}{A_0} = (1 - e^{-\lambda T}),$$

an equation which is completely in accord with the experimental curve in Fig. 434.

Further, if the activity recovers by half the final amount in 4 days or 96 hours,

$$0.5 = 1 - e^{-96\lambda},$$

from which,

$$\lambda = 0.0072,$$

or, if time be reckoned in seconds instead of hours—

$$\lambda = 2 \times 10^{-6}.$$

Similar measurements made upon uranium show that Ur X decays exponentially and Ur recovers in a similar manner. In this case the time for half decay or recovery is 22 days, and therefore

$$\lambda = 3.6 \times 10^{-7}.$$

These constants are independent of the physical condition or state of chemical combination of the materials, for they are the same whatever the salt of uranium or thorium employed, and go on in exactly the same manner and at the same rate at the lowest and highest temperatures that can be employed. Hence they are changes occurring in the atom itself, and are independent of its motion and of its relation to other atoms.

Radioactive Constant.—A definite meaning may be given to the constant λ , according to the above theory; it is the fraction of the amount of the product present which decays in unit time, and is called the radioactive constant of the product.

For the activity is measured by the ionisation produced, and this is almost entirely due to the α rays. Assuming that the ionisation produced by one α particle is constant, and that every atom as it changes projects the same number of α particles—

$$\frac{n_t}{n_0} = \frac{A_t}{A_0} = \epsilon^{-\lambda t},$$

where n_t and n_0 are the number of atoms changing respectively at time t , and when in radioactive equilibrium respectively.

Now, if N_t be the number of atoms of the product remaining after time t from separation from the parent substance—

$$n_t = \frac{dN_t}{dt}, \text{ or, } N_t = \int_t^\infty n_t dt,$$

since the number N_t will all subsequently change in the interval between t and ∞ .

$$\therefore N_t = \int_t^\infty n_0 \epsilon^{-\lambda t} dt = \frac{n_0}{\lambda} \epsilon^{-\lambda t}.$$

Hence the number N_0 at time $t = 0$, or the number present for radioactive equilibrium, is—

$$N_0 = \frac{n_0}{\lambda}.$$

Again, when equilibrium is reached, the number of atoms decaying per second is equal to the number produced per second, or—

$$n_0 = q_0$$

so that,

$$N_0 = \frac{q_0}{\lambda}, \text{ or, } \lambda = \frac{q_0}{N_0},$$

and λ , the radioactive constant, is the ratio of the number of atoms changing per second to the number present.

Thorium Emanation.—From his experiments upon thorium, Rutherford¹ found that a substance in very minute quantity and having a gaseous form is given off by compounds of thorium, and may be carried into the vessel in which the ionisation is measured, by drawing the air from the neighbourhood of the thorium into the ionisation chamber. This effect is not due to the ionisation of the gas produced in the neighbourhood of the thorium and carried along by the moving air; since passing through porous material does not remove it (see p. 478), and if the thorium be wrapped in paper to absorb the α rays, which produce most of the ionisation, the substance readily diffuses through the paper. The discoverer called this an “emanation.” Rutherford and Soddy² investigated the emanation as follows.

Air bubbled through strong sulphuric acid in A (Fig. 436) passes over the active material, wrapped in paper, in the tube B, through the

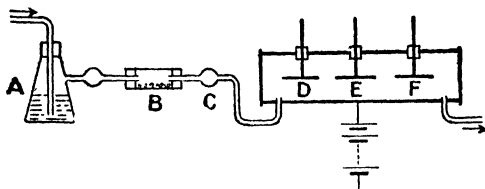

FIG. 436.

bulb C, packed with cotton-wool, and into the ionisation vessel containing the three separate conductors D, E, and F, either of which may be connected to the electrometer. The outer tube is joined to one pole of a battery, and the current from this to the electrometer measures the ionisation in the neighbourhood of D, E, or F. The current is less, the further the emanation has had to travel from the active material, so that for a given air velocity, the currents to D, E, and F form a diminishing series. By stopping the air current and measuring the fall of ionisation, it was shown that the activity of the emanation falls exponentially, reaching half its value in 1 minute. Thus the radioactive constant in this case is given by $0.5 = 1 - e^{-\lambda t}$, or $\lambda = 1.15 \times 10^{-2}$.

By placing a thorium salt, wrapped in paper to cut off direct ionisation, in a closed vessel, the ionisation, and the current produced on account of it, rise owing to the production of the emanation.

¹ E. Rutherford, *Phil. Mag.*, 49, p. 1. 1900.

² E. Rutherford and F. Soddy, *Phil. Mag.*, 4, p. 569. 1902.

By measuring the ionisation current at intervals, it is found to increase exponentially, rising to half its value in one minute, the time of the decay of the emanation to one-half; we may therefore conclude that the formation and decay of the emanation are related to each other in a similar manner to those of thorium X, the rate, however, being different.

It was shown by Rutherford and Soddy¹ that the thorium X, and not the thorium itself, is the source of the emanation, for, on removing the Th X by precipitating the thorium as on p. 509, the thorium has lost its power of producing emanation, while this is found now in the Th X. Moreover, the Th recovers its emanating power and the Th X loses it, both changes being half completed in 4 days. Thus the emanating power of Th X is proportional to its activity, and it is reasonable to conclude that the Th X changes to emanation, the process being accompanied by the projection of α particles.

It should be remembered that Th X is a solid, and remains in the parent thorium, while the emanation is a gas and rapidly diffuses from the material. Rutherford and Soddy condensed the emanation in liquid air, in which case it adhered to the walls of the containing tube, passing off again in the gaseous form on rise of temperature. The condensation is not abrupt, beginning at about -120° C. and continuing over a range of about 30° to -150° C.

Excited Radioactivity.—It was found by Prof. Rutherford² that a solid body placed in the emanation of thorium possesses a high radioactivity when removed from the emanation, and, further, that the amount of this excited activity is increased when the body is a negatively charged conductor, but the body does not receive any such activity if positively charged. The amount of excited activity is independent of the nature of the material upon which it is formed, except that when the body is to be negatively charged it is essential to use a conductor. That the excited activity is due to the emanation, may be shown by covering the active thorium by a few sheets of paper to cut off the radiation of α particles, when the production of the excited activity is still produced by the emanation which diffuses through the paper. If the thorium be covered by a sheet of mica sealed round the edges to keep in the emanation, the production of excited activity ceases.

That the excited activity is a product of change of the emanation may be shown by introducing a quantity of emanation into an ionisation vessel. The conductivity doubles in four or five hours, and if the emanation be then removed, the excited activity deposited on the walls of the vessel decays. Rutherford found that the excited activity produced by long exposure to the emanation decays to half in 11 hours, and that the recovery curve is related to it as the decay and recovery curves of thorium X.

¹ E. Rutherford and F. Soddy, *Phil. Mag.*, 4, p. 569. 1902.

² E. Rutherford, *Phil. Mag.*, 49, p. 161. 1900.

The excited activity could be removed by dissolving in hydrochloric or sulphuric acids, but its mass is undetectable. It also resides on the surface, since it may be partially removed by scraping.

Prof. Rutherford gave the name of emanation X to the excited activity, since it is related to the emanation as thorium X is to thorium.

The thorium emanation itself emits only α rays, but after sufficient time has elapsed for appreciable formation of the excited activity, β and γ rays are also emitted. The emanation is enclosed in a copper vessel,¹ to absorb the α rays but to allow the β and γ rays to pass through. At first there is no ionisation outside the vessel, but after a time this does take place, and reaches a maximum in three or four hours. On removing the emanation by blowing it out of the vessel, this ionisation which is due to the β and γ rays emitted by the excited activity on the walls of the vessel does not disappear at once, but decays gradually.

The excited activity behaves differently according to whether the exposure of the body to the emanation is of short or long duration.² If short, the activity increases for several hours and then falls exponentially, but if the exposure has been long there is a fall from the start. Prof. Rutherford has explained this on the assumption that there are really two successive changes occurring, the first a "rayless" change which is half complete in 55 minutes, and the second a change with emission of α , β and γ rays, which is half complete in 11 hours. The two products involved, he has named thorium A and thorium B. The rise in activity after short exposure is due to the formation of Th B from Th A.

The product of change of Th B had not until recently been observed to be radioactive, but it is now known that there are two short-lived products Th C and Th D.

Radium.—We have followed the radioactive changes taking place in the case of thorium in some detail, but it must be understood that the historical order of presentation has not been adhered to. It will be simpler to trace the changes occurring in the case of other substances now that those for one have been described.

The discovery of radium has been described on p. 500.

The emanation of radium is not readily liberated from solid radium salts, but is occluded by them. On heating the salt, the emanation is liberated, and a similar result is obtained by dissolving the salt in water.

Radium emanation is produced by a direct change from the radium itself, and not from a product of radium. Thus there is no radium product corresponding to thorium X. The emanation decays to one-half in 3.71 days, and the radioactive constant λ is therefore

¹ E. Rutherford and F. Soddy, *Phil. Mag.*, 5, p. 445. 1903.

² E. Rutherford, *Phil. Mag.*, 5, p. 95. 1903.

(2.16×10^{-6}).¹ It is also condensed at low temperature, the temperature of condensation being about -155° C.

The *excited activity* of radium emanation is similar to that met with in the case of thorium, and was first noticed by M. and Mme. Curie,² who showed that this is not due to the direct radiation from radium, but to the emanation, since it was produced on the solid when shielded from the direct radiation of the active salt. Like the excited activity of thorium, the deposit takes place much more readily upon a negatively electrified conductor than upon an uncharged body, but, unlike the case of thorium, a slight deposit will take place upon a positively charged conductor.

The decay curves for short exposure are complicated, and on the analogy with the case of thorium, Rutherford has concluded that the excited activity of radium consists of six products, the substances being called respectively Ra A, Ra B, Ra C, Ra D, Ra E, and Ra F. The first three form a group in which the changes are rapid, and the last three a group of slow change. It is now known that radium is a product of the uranium series, but is not the direct product of uranium X. In fact, there are two long-lived products between uranium X and radium. The first, uranium 2, has radioactive constant 1.0×10^{-14} and changes to the second, ionium, with emission of one α particle. Ionium changes to radium, with emission of one α particle of small range. The radioactive constant of ionium is 1×10^{-13} .

Volume of Emanation.—The volume of the emanation from radium has been determined by Prof. Ramsay and Mr. Soddy,³ who collected the gases evolved in 8 days from a radium solution. These consisted largely of oxygen and hydrogen, which were caused to combine by producing an explosion, the excess of hydrogen being removed by caustic soda. The remainder is dried by means of phosphorus pentoxide, and consists of the emanation; it is collected in a capillary tube and measured. It was found that the volume diminished exponentially, being reduced to half its original value in 4 days. In a second experiment the volume, instead of decreasing, increased, this being attributed to the formation of helium, which in the first experiment was absorbed by the glass walls of the tube.

Emission of Heat by Radium.—The fact that radium compounds are permanently at a higher temperature than their surroundings, and therefore that radium is constantly emitting heat, was first pointed out by Curie and Laborde.⁴ This difference of temperature is of the order of 2° C., but depends of course on the rate of escape of the emitted heat from the radium, as determined by the size of the specimen and the nature of its immediate surroundings. The rate of emission of heat was measured by the Bunsen ice calorimeter, and also by finding the rate at which heat should be electrically supplied to

¹ E. Rutherford and F. Soddy, *Phil. Mag.*, 5, p. 445. 1903.

² P. Curie and Mme. Curie, *Comptes Rendus*, 129, p. 714. 1899.

³ W. Ramsay and F. Soddy, *Proc. Roy. Soc.*, 73, p. 346. 1904.

⁴ P. Curie and A. Laborde, *Comptes Rendus*, 136, p. 673. 1903.

a similar and similarly situated mass of non-active material to maintain the same temperature. They found that radium emits heat at the rate of about 100 calories per hour per gramme of radium.

At a later date it was found by M. and Mme. Curie, in conjunction with Prof. Dewar, that the rate of emission of heat is still the same when the temperature is reduced to that of liquid oxygen, but Prof. Dewar thinks that at the temperature of liquid hydrogen the rate is slightly increased.

The heat emitted during several stages of the radioactive changes occurring in radium was measured by Prof. Rutherford and Mr. Barnes,¹ who placed the material contained in a small tube in turn into two flasks containing dried air, connected by means of a differential manometer. The difference in level in the manometer produced by transferring the radioactive material from one flask to the other is a measure of the rate of emission of heat, and was calibrated by finding the current in a fine piece of platinum wire of known resistance, that will produce the same effect.

The emanation was then removed from the radium, when the rate of emission fell rapidly to a minimum of 30 per cent., and then rose gradually to its original value in about a month.

The emanation was then tested, and it was found that its rate of emission was exactly complementary to that of the de-emanated radium; in fact, the heat emission follows the same changes as the activity as measured by the ionisation produced by the α rays, and hence it is concluded that the heat emission is proportional to the activity measured by the α rays, and that the expulsion of each α particle corresponds to a constant production of heat.

For the change from radium to the emanation, the activity, as measured by the rays, is about 25%, and the heat emission also about 25% of the total emission; for the change from emanation to Ra A, the percentages are respectively 33 and 41, and for the remaining changes 42 and 34.

The total emission of heat by the emanation during its whole life may then be found on the assumption that the heat emission is proportional to the number of atoms breaking up per second;

$$\text{for, } n_t = n_0 e^{-\lambda t},$$

$$\therefore \text{total number of atoms} = \int_0^{\infty} n_t dt = n_0 \int_0^{\infty} e^{-\lambda t} dt = \frac{n_0}{\lambda}.$$

$$\text{Hence, total emission of heat} = \frac{\text{rate of emission at start}}{\lambda}.$$

Now, from Rutherford and Barnes' experiment, the rate of emission of heat by the emanation alone from 1 gramme of radium is about 40%

¹ E. Rutherford and H. T. Barnes, *Phil. Mag.*, 7, p. 202. 1904.

of the total emission, that is, about 40 calories per hour, or $\frac{1}{90}$ calorie per second. Now, $\lambda = 2.1 \times 10^{-6}$,

$$\therefore \text{total heat emission} = \frac{10^6}{2.1 \times 90} = 5300 \text{ calories.}$$

And similarly in its whole life radium emits a quantity of heat of the order of 10^{10} calories. When it is remembered that the union of hydrogen and oxygen to form 1 gramme of water causes an evolution of 3900 calories, the enormous store of energy within the atom in the case of the radioactive substances will be realised.

This store of energy within the atom must be taken into account in estimating the age of the earth and sun. On the theory of Helmholtz, that the energy of the sun is derived from its own shrinking, the age of the sun would be, according to Lord Kelvin, about 100 million years; but this period may be considerably extended if the energy is partly derived from radioactive changes. Although the radium lines have not been detected in the solar spectrum, the helium lines are there, and helium has been shown to be one of the ultimate products of radioactive change (p. 519).

It has been shown by Prof. Strutt that a mass of 270 tons of radium in the interior of the earth would account for the actual temperature gradient of 1°C . for about 100 feet depth, near the surface, and from an estimate of the amount of radium from the known contents of various minerals, more than this radium would exist in the earth if its material were of the same constitution throughout.

Uranium.—The simplest radioactive change known is presented by uranium, which does not produce any emanation, but emits α rays in changing to uranium X. This decays to half its value in 25 days, and in decaying emits β and γ rays.

Actinium.—The course of the changes in the case of actinium may be followed from the table on p. 522, in which it is seen that one of the products, the emanation, has an extremely short life.

Number of α Particles emitted by Radium.—Great importance attaches to a knowledge of the absolute number of α particles emitted by radioactive materials in a given time, and several methods have been adopted to determine this quantity. The most obvious method is to count the number of scintillations produced by a known amount of radium when the α particles fall upon a screen of zinc sulphide, and this method was adopted by Regner.¹ An uncertainty in the interpretation of the result arises from the fact that we are not sure that every α particle produces a scintillation. The problem has been attacked by an entirely different method by Rutherford and Geiger.² They observed the increase of conductivity of a gas as each α particle is shot into it. The active material in the form of the active deposit of

¹ Regner, *Sitz. Ber. der K. Preuss. Akad. der Wiss.*, **38**, 1909.

² E. Rutherford and H. Geiger, *Proc. Roy. Soc., A.*, **81**, pp. 141 and 162. 1908.

radium, situated upon the tip of a conical glass rod, A (Fig. 437), emits α rays in all directions. Those which fall upon the small aperture in the glass tube B, covered with a thin layer of mica, enter the measuring chamber C. Since each α particle in its travel produces about 43,000 ions, the increase in conductivity of the gas in C produced by one α particle may under favourable conditions become evident. The potential difference between the wire D and the outside tube C is adjusted until the saturation current is flowing from one to the other. The presence of a few extra ions will then, if the sparking stage is on the point of being reached, produce a large increase in the current, and it was found

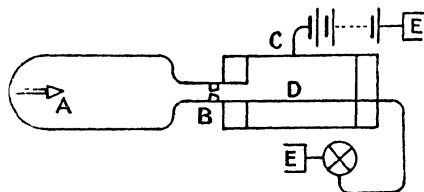

FIG. 437.

that a comparatively large throw of the electrometer needle occurred irregularly, but on the average something like four times a minute. The number of these impulses for a considerable period is counted, and so the number of α particles entering chamber C per minute is known. Since the α rays are emitted from the active material uniformly in all directions, the total number emitted in a given time is to the number passing through B in the ratio of 4π to the solid angle subtended by the aperture in B at the point A. The ratio of the activity of the specimen to that of one gramme of radium was obtained during the experiment by means of the ionisation produced by the γ rays, and it was found as a result that the radium C in one gramme of radium, emits 3.4×10^{10} α particles per second. Hence, counting the four α particles emitted by radium and its products in the course of their changes, one gramme of radium emits in all 13.6×10^{10} α particles per second.

Charge on the α Particle.—Rutherford and Geiger also determined the total charge carried by the α particles from a deposit of radium C, by allowing this to fall on a conductor of known capacity, and finding the rise of potential per second, the β and δ rays being deflected away from the conductor by means of a magnetic field. From their results, together with a knowledge from the previous experiment of the number of α particles emitted per second, it was found that each particle carries a charge of 9.3×10^{-10} electrostatic or 3.1×10^{-20} electromagnetic units, or twice the charge carried by a positive ion in the case of

hydrogen in electrolysis. Now, $\frac{e}{m}$ is 6×10^3 in electromagnetic units for the α rays (p. 503), and $\frac{e}{m}$ for hydrogen in electrolysis is 9.6×10^3 , and since e' is now seen to equal $2e$, it follows that $m' = \frac{9.6}{6} \cdot 2 \cdot m = 3.2m$, and the atomic weight of the α particle is

3.2. That of the helium atom is 3.9, and hence it is probable that the helium atom is an α particle which has lost its positive or acquired a negative charge and become neutral (also see p. 517).

Life of Radium.—Since the time that has lapsed since the discovery of radium is only an extremely small fraction of its whole life, it is impossible by direct observation of the rate of decay to determine this. Several computations by indirect methods have been made by Prof. Rutherford.¹

The rate of emission of α particles by a thin layer of radium bromide is found by measuring the current carried on their account to a neighbouring conductor, the experiment being performed at high vacuum to eliminate the disturbance due to ionisation of the gas, and with a strong transverse magnetic field to cause the slowly moving negative electrons to be bent back to their point of origin. The radium is at its minimum activity, the radioactive products having been removed, so that the β rays, which are only emitted by Ra C, do not cause disturbance. In this way it was found that if the charge on the α particle be taken as 1.13×10^{-20} electromagnetic units, that is, the charge on an electron, the total number of α particles emitted by 1 gramme of pure radium at its minimum activity is 6.2×10^{10} . Using the active deposit upon lead, it was found in a similar manner that the Ra C in 1 gramme of radium emits 7.3×10^{10} β particles per second. This is probably slightly too high owing to the difficulty of ensuring that those which enter the supporting lead are absorbed, owing to their high power of penetration. Since one atom of radium in breaking down probably emits one α particle at the first stage and one β particle in all, it appears probable, from these data, that in 1 gramme of radium 6.2×10^{10} atoms break up per second or 1.95×10^{18} per year. If 1 cubic centimetre of hydrogen contains 3.6×10^{19} molecules, and has a mass of 8.96×10^{-5} gramme, 1 gramme of hydrogen contains $\frac{2 \times 3.6 \times 10^{19}}{8.96 \times 10^{-5}}$ atoms, and the atomic weight of radium being 225, 1 gramme of it contains—

$$\frac{2 \times 3.6 \times 10^{19}}{225 \times 8.96 \times 10^{-5}} = 3.6 \times 10^{21} \text{ atoms,}$$

and the fraction breaking up in unit time or λ (p. 512) is—

$$\frac{1.95 \times 10^{18}}{3.6 \times 10^{21}} = 5.4 \times 10^{-4},$$

where the year is taken as the unit of time. This gives a decay to half in 1280 years, or an average life $\left(\frac{1}{\lambda}\right)$ of 1850 years.

Later experiments have shown that the charge on the α particle is

¹ E. Rutherford, *Phil. Mag.*, 10, p. 193. 1905.

twice that on the electron, and also that the number of α particles emitted by 1 gramme of radium per second in minimum activity is 3.4×10^{10} , or 1.07×10^{18} per year, which would change the value of λ to $\frac{1.07 \times 10^{18}}{3.6 \times 10^{21}} = 3 \times 10^{-4}$, and the decay to one-half occurs in 3300 years

Another estimate is formed by considering the rate of emission of heat. From the mass and velocity of the α particle its kinetic energy would be about 5.9×10^{-6} ergs, and since 1 gramme of radium emits about 100 calories per hour,

$$5.9 \times 10^{-6} \times n \times 3600 = 100 \times 4.2 \times 10^{-7},$$

or, $n = \frac{4.2}{5.9 \times 3.6} \times 10^{13} = 2.0 \times 10^{11},$

on the assumption that the heat is produced by the bombardment of the α particles upon the substance and its surroundings, n being the total number emitted per second by radium and the radioactive products in equilibrium with it. For the radium in its condition of minimum activity the number is one quarter of this, that is, 5×10^{10} per second, which is in fair agreement with the number 3.4×10^{10} on p. 518 from the charge, and would, according to the above reasoning, mean a decay to half in 1600 years.

Further consideration of the volume of the emanation emitted in a given time (p. 515) led to a value of 1050 years for the period of decay to one-half.

Origin of Radium.—Since radium is continually undergoing radioactive change, falling to half its value in about 2000 years, the average life of a radium atom is of the order of 3000 years. Hence, the presence of radium in certain minerals would appear to imply its formation in these minerals at some not very remote period. It has been suggested that uranium may be the parent of radium, a supposition which seems the more probable because uranium and radium always occur together in minerals. Moreover, an exhaustive examination of the minerals containing radium has shown that the proportion of radium to uranium is practically constant. This is exactly what we should expect if radium were a product of uranium, for equilibrium would be reached when the rate of production of radium is equal to its loss by decay. Also the formation of radium in a mass of one kilogramme of uranium has been observed by Soddy,¹ the radium being first removed from the solution, which was subsequently tested at intervals for the presence of radium. The rate of production of radium is smaller than would be expected if radium is directly formed from uranium X, and hence it is likely that at least one inactive product is formed from uranium X before the formation of radium.

¹ F. Soddy, *Phil. Mag.*, 9, p. 768. 1905.

We have seen (p. 519) that the α particle expelled during many of the radioactive changes is probably an atom of helium, the atomic weight of which is 4. According to Prof. Rutherford, uranium probably contains three α ray products, and hence in losing the three α particles the loss in atomic weight would be 12. The atomic weight of uranium being 238.5, that of the product when the three α particles have been lost is $238.5 - 12 = 226.3$. The atomic weight of radium is 225, which is a significant fact.

Further, radium expels in the course of its changes five α particles, and a further loss of $5 \times 4 = 20$ in the atomic weight, which means a loss of 32 from the uranium atom, and would bring the atomic weight to 206.5. Since the atomic weight of lead is 206.9, it is at least possible that lead is the ultimate product of the change of uranium, radium being one of the intermediate long-lived stages. This conclusion gathers weight from the fact that lead is always found in the minerals containing uranium and radium.

Table of Radioactive Substances.—The table of radioactive changes on p. 522 is complete in respect to the direct line of radioactive change, but certain side products which, so far as is known, do not lead to further changes are omitted. A full account of the original researches by which our knowledge has been built up would be out of place here, and the student interested in the subject is advised to consult works such as that of Mme. Curie¹ and "Radioactivity" by Prof. Rutherford.

Atmospheric Radioactivity.—It has been known for a very long time that air under ordinary conditions is not a perfect insulator; a charge leaks slowly from a charged conductor, the leak not being attributable to the want of insulation of the support. The conduction by air in a closed space was investigated by C. T. R. Wilson,² who found that it had all the characteristics of conduction due to ionisation. The current did not increase indefinitely with the voltage, a saturation current being reached. Further, the rate of leak increases with the volume of the space and directly as the pressure, and corresponds at the ordinary pressure to the presence of about 20 ions per cubic centimetre.

The air in caves and other underground spaces exhibits a greater conductivity than the normal free air, which extra conductivity is not merely due to the fact that the air is at rest and unchanged, but to its proximity to the earth and rocks in its neighbourhood.

On maintaining an exposed wire at a high negative potential in the free air or in underground spaces, Elster and Geitel³ found that on coiling it up and placing it in the ionisation chamber of an electro-scope it produces considerable ionisation, in fact it has been rendered radioactive, and that the activity decreases logarithmically with time, a result which makes it extremely probable that there is an active

¹ "Radioactivité," by Mme. Curie. 1910.

² C. T. R. Wilson, *Proc. Camb. Soc.*, 11, p. 32. 1900.

³ J. Elster and H. Geitel, *Phys. Zeitschr.*, 3, p. 574. 1902.

	Time of decay to half	Radioactive constant λ	Type of ray emitted during decay
Uranium 1	5×10^9 years	4.3×10^{-18}	α .
Uranium X_1 . . .	24.6 days	3.3×10^{-7}	β .
Uranium X_2 . . .	1.15 min.	1.0×10^{-2}	β .
Uranium 2	2×10^6 years	1.0×10^{-14}	α .
Ionium	2×10^1 years	1.0×10^{-13}	α .
Radium	1730 years	1.26×10^{-11}	α .
Emanation	3.85 days	2.085×10^{-6}	α .
Ra A	3.0 min	3.85×10^{-3}	α .
Ra B	26.7 min.	4.33×10^{-4}	β .
Ra C	19.5 min.	5.93×10^{-4}	α and β .
Ra D	16.5 years	7.3×10^{-9}	β .
Ra E	5.0 days	1.6×10^{-6}	β .
Ra F	136 days	5.9×10^{-5}	α
Lead (?)	—	—	—
Thorium	1.8×10^{10} years	1.2×10^{-18}	α .
Mésothorium 1 . .	5.5 years	4.0×10^{-9}	—
Mésothorium 2 . .	6.2 hours	3.1×10^{-3}	β .
Radiothorium . . .	2.0 years	1.09×10^{-5}	α
Th X	3.64 days	2.2×10^{-6}	α .
Emanation	54 seconds	1.28×10^{-2}	α .
Th A	0.14 seconds	5.0	α .
Th B	10.6 hours	1.8×10^{-1}	β .
Th C	60 min.	1.9×10^{-4}	α .
↓ Th D	3.1 min.	3.7×10^{-3}	β .
Th C_2	10^{-11} sec.	7×10^{10}	α .
Actinium	—	—	—
Radio-actinium . .	19.5 days	4.1×10^{-7}	α .
Act X	11.4 days	7.6×10^{-7}	α .
Emanation	3.9 seconds	1.8×10^{-1}	α .
Act A	2.3×10^{-3} sec.	3.5×10^2	α .
Act B	36.1 min.	3.2×10^{-4}	β .
Act C	2.15 min.	5.37×10^{-3}	α .
Act D	4.71 min.	2.26×10^{-3}	β .
Potassium	—	—	β .
Rubidium	—	—	β .

deposit upon it due to some radioactive emanation in the atmosphere. Rutherford and Allen¹ in this way obtained an active deposit which decayed to half its value in 45 minutes. The active deposit could be removed by chemical means or scraped off the wire just like the active deposit from radium or thorium emanation. Later experimenters, however, did not find the active deposit to be of so simple a character, the law of decay being more complex.

The presence of radioactive emanations in the atmosphere is universal, Gockel² finding the emanations of radium and thorium at an altitude of 2300 metres, and Eve³ that the activity of air over the sea is about the same as that over the land. Many observers have obtained a radioactive residue on evaporating to dryness, freshly fallen rain or snow, C. T. R. Wilson⁴ obtaining a residue which disappeared in several hours.

It is extremely probable that the emanation in the atmosphere arises from radioactive materials in the earth and slowly diffuses away. The condition of the earth would certainly affect the rate at which this diffusion occurs, a dry and porous soil allowing it to escape rapidly, and a moist or hard one tending to retain it, so that for equilibrium, the latter would be expected to possess the higher radioactivity. This was found to be the case by Gockel.⁵ Further evidence is afforded by the fact that fluctuations occur; when the barometer is low the activity of the atmosphere is greater, due to the same rapid diffusion outwards of the air containing emanation in the surface layers of soil.

An examination of various soils and rocks by Elster and Geitel⁶ has shown that most of these contain radioactive emanations, but the amounts vary greatly with the material and the locality. The same experimenters obtained an emanation by burying pipes in the ground and pumping up the air from them, this being found to be strongly active.

The emanation from various localities is not always of the same kind, that of thorium being found in some places, and that of radium in others.

Universal Penetrating Radiation.—In addition to the radioactivity due to the emanations present in the atmosphere, there is evidence of the existence of a highly penetrating radiation, for H. L. Cooke⁷ found that a layer of lead 5 cms. in thickness placed round the electroscopes reduced the rate of discharge by 30 per cent., but attempts to determine the direction from which this radiation came failed to show any inequality in different directions.

¹ E. Rutherford and S. J. Allen, *Phil. Mag.*, **4**, p. 704. 1902.

² A. Gockel, *Phys. Zeitschr.*, **8**, p. 701. 1907.

³ A. S. Eve, *Phil. Mag.*, **13**, p. 248. 1907.

⁴ C. T. R. Wilson, *Proc. Camb. Soc.*, **12**, pp. 17 and 85. 1903.

⁵ A. Gockel, *Phys. Zeitschr.*, **9**, p. 304. 1908.

⁶ J. Elster and H. Geitel, *Phys. Zeitschr.*, **5**, pp. 11 and 321. 1904.

⁷ H. L. Cooke, *Phil. Mag.*, **6**, p. 403. 1903. •

CHAPTER XVII

ELECTRONS

Faraday Tubes.—An ultimate explanation of physical phenomena is probably unattainable, but the order of development and abandonment of the successive hypotheses that have been employed to account for electrical and optical phenomena, and eventually for the two together, is an interesting and important study. The general tendency during the last century was to concentrate attention upon the medium in which matter is immersed, as the vehicle for the transference of energy from one place to another. Faraday explained electric and magnetic phenomena in terms of tubes of induction, and in optics the elastic solid theory, in spite of the great difficulties involved, was almost universally employed in explaining the propagation of the wave motion which we call light. The fundamental idea that the same medium may be used for the explanation of both electromagnetic and optical phenomena, in fact that light is an electromagnetic phenomenon, is due to Maxwell, but the further development, that the Faraday tubes with the properties attributed to them by Maxwell, alone are sufficient, is due to Sir J. J. Thomson, who developed this idea in his "Recent Researches in Electricity and Magnetism."

In Chapter XIV we found the velocity of propagation of an electromagnetic disturbance, from Maxwell's equations, to be $\frac{1}{\sqrt{k\mu}}$, and we afterwards used Thomson's Faraday tubes in the explanation of this propagation. If, however, a Faraday tube have a longitudinal tension, $\frac{2\pi D^2}{k}$ (p. 135), and be endowed with mass $4\pi\mu D^2$ per unit length (p. 424), then a lateral disturbance at any point would be propagated along the tube, as a lateral disturbance is propagated along a string under tension, the velocity of which is proved in works on Sound to be $\sqrt{\frac{F}{m}}$, where F is the tension, and m the mass per unit length. Now, in the case of a stretched string, the only force tending to restore the string to its original shape is F the tension in it, there being no lateral pressure over its sides. In the case of the Faraday tube, however, we found on p. 136 that when the tube is curved there is a

longitudinal restoring force $\frac{2\pi D^2}{k}$ due to its own tension, and also a component $\frac{2\pi D^2}{k}$ due to the lateral pressure of the neighbouring tubes, and thus F , in the problem of the string, must be replaced in the case of the Faraday tube by $\frac{4\pi D^2}{k}$. The velocity of propagation we should therefore expect to be $\sqrt{\frac{4\pi D^2}{k} \cdot \frac{1}{4\pi\mu D^2}} = \frac{1}{\sqrt{k\mu}}$, which is entirely in accordance with the result obtained from Maxwell's equations.

Mass of Electrically-charged Sphere.—A uniformly charged sphere possesses a radial electrical field, the electric intensity E in its neighbourhood being $\frac{e}{kr^2}$, r being the distance of the point considered from the centre of the sphere, k the dielectric constant of the medium surrounding the sphere, and e the total charge. Thus, at every point, the electric displacement, or number of Faraday tubes per square centimetre, is $D = \frac{e}{4\pi r^2}$, the total number of Faraday tubes arising

upon the sphere being e . If the sphere be originally at rest we shall require some force to act upon it to put it in motion, quite apart from the question of its mechanical mass, for the Faraday tubes in motion possess energy, and on this account work must have been done. Let us consider the equivalent mass of the tubes in the small element of space at P (Fig. 438) due to the motion of the charged sphere in the direction Ox with velocity v . The angle between the direction of the tube and its velocity is θ , and therefore the equivalent mass

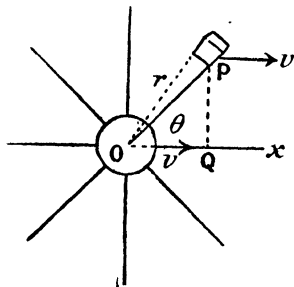

FIG. 438.

per unit volume of the tube is $4\pi\mu D^2 \sin^2 \theta$ (p. 424), that is $\frac{\mu e^2 \sin^2 \theta}{4\pi r^4}$.

Now, the area of the face of the element in the plane of the diagram is $r \cdot d\theta \cdot dr$, and for all such elements lying upon the circumference of the circle where radius is QP and whose plane is perpendicular to Ox , the electric intensity is the same, and consequently the mass of the tubes in the ring described by the area $rd\theta \cdot dr$ if the diagram be rotated about Ox is—

$$\begin{aligned} &\text{Volume of ring} \times \left(\frac{\mu e^2 \sin^2 \theta}{4\pi r^4}\right) \\ \text{But, volume of ring} &= 2\pi \cdot PQ \cdot rd\theta \cdot dr \\ &= 2\pi r \sin \theta \cdot rd\theta \cdot dr \\ &= 2\pi r^2 \sin \theta \cdot d\theta \cdot dr. \end{aligned}$$

Therefore, mass of ring due to the Faraday tubes

$$\begin{aligned} &= 2\pi r^2 \sin \theta \cdot d\theta \cdot dr \cdot \frac{\mu e^2 \sin^2 \theta}{4\pi r^4} \\ &= \frac{\mu e^2 \sin^3 \theta \cdot d\theta \cdot dr}{2r^2}. \end{aligned}$$

Hence for the whole of space surrounding the sphere,

$$\begin{aligned} \text{Mass due to Faraday tubes} &= \int_0^\pi \int_a^\infty \frac{\mu e^2 \sin^3 \theta \cdot d\theta dr}{2r^2} \\ &= \frac{\mu e^2}{2} \int_0^\pi \int_a^\infty \frac{\sin^3 \theta}{r^2} d\theta \cdot dr, \end{aligned}$$

where a is the radius of the sphere.

Integrating first with respect to r , we have—

$$\int_a^\infty \frac{dr}{r^2} = - \left[\frac{1}{r} \right]_a^\infty = \frac{1}{a},$$

$$\therefore \text{mass} = \frac{\mu e^2}{2a} \int_0^\pi \sin^3 \theta \cdot d\theta.$$

$$\begin{aligned} \int_0^\pi \sin^3 \theta \cdot d\theta &= \int_0^\pi \sin \theta (1 - \cos^2 \theta) d\theta = - \int_1^{-1} (1 - \cos^2 \theta) d \cos \theta \\ &= - \left[\cos \theta - \frac{\cos^3 \theta}{3} \right]_1^{-1} \\ &= - \left[-2 + \frac{2}{3} \right] = \frac{4}{3}, \\ \therefore \text{mass} &= \frac{2\mu e^2}{3a}. \end{aligned}$$

This mass must be added to any mechanical mass that the sphere may possess, in order to obtain its total mass. It has been calculated on the assumption that the Faraday tubes retain these symmetrical distributions when the sphere is put into motion. Now, this is not strictly true; the Faraday tubes tend to set themselves at right angles to the direction of motion. Heaviside¹ has shown that for a charge moving with velocity v , the distribution of electric displacement is the same as though the body were at rest, but the dielectric constant in the direction of motion was reduced in the ratio $\left(1 - \frac{v^2}{V^2}\right)$, where V is the velocity of light. This effect would therefore be small for velocities much below that of light, and if the velocity

¹ O. Heaviside, "Electromagnetic Theory," vol. 1.

of light could be attained, the value of k in this direction would be zero. Hence the Faraday tubes, as the velocity increases, tend to become more and more displaced towards the equatorial plane, that is, into a position in which their motion is at right angles to their length, and their effective mass therefore increases. In the limiting case when $v = V$ they are confined to an infinitely thin sheet at right angles to the direction of motion, the value of D , and likewise the electromagnetic mass of the charge, then being infinite.

Sir J. J. Thomson¹ has calculated the mass of a moving charge in terms of its velocity.

It is interesting to note that in finding the ratio $\frac{e}{m}$ for the β particles emitted by radioactive substances Kaufmann (p. 505) found the ratio to diminish as the velocity increased. Since it is very unlikely that e varies, we are driven to the conclusion that m increases, and Abraham,² on the assumption that the mass is entirely electromagnetic, calculated the deviations in electric and magnetic fields and found these to be very well in agreement with Kaufmann's observations.

Moving Charge equivalent to an Electric Current.—Since a charge moving with constant velocity is accompanied by its Faraday tubes moving with the same velocity, the magnetic field at any point may be expressed in terms of the movement of the tubes; in fact, the energy found for the moving tube on p. 526 is possessed on account of this magnetic field. On p. 424 we saw that the magnetic field is $4\pi Dv \sin \theta$.

Now, in Fig. 438, the value of D at the point P is $\frac{e}{4\pi r^2}$, and therefore the magnetic field is

$$4\pi \cdot \frac{e}{4\pi r^2} \cdot v \sin \theta = \frac{ev \sin \theta}{r^2}.$$

It is directed from back to front if the moving charge e is positive and from front to back if e is negative. The value is the same for all points upon a circle having Q as centre and QP as radius, whose plane is at right angles to the direction of motion, and its direction is along the circle. The magnetic lines of force are therefore circles having their centres upon Ox and their planes at right angles to it.

On comparing this expression for the magnetic field with that due to a current element $i \cdot ds$ at point O , which, according to Ampère's rule given on p. 53 is $\frac{i \cdot ds \sin \theta}{r^2}$, we see that, for purposes of calculating magnetic field, the quantity ev for the moving electric charge is equivalent to $i \cdot ds$ for the continuous current.

¹ J. J. Thomson, "Recent Researches in Electricity and Magnetism."

² M. Abraham, *Phys. Zeitschr.*, 4, p. 57. 1902.

In the case of a charge e moving round a circle of radius r in periodic time T (Fig. 439), the Faraday tubes continually pass the centre of the circle O with velocity $\frac{2\pi r}{T}$, since each tube at the instant

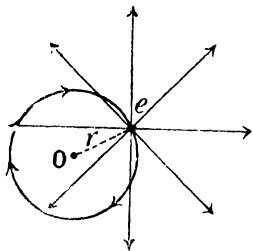

FIG. 439.

of passing O is moving at right angles to its own length and has the same velocity as e .

Now, at O the value of D is $\frac{e}{4\pi r^2}$,

\therefore magnetic field at $O = 4\pi Dv$

$$= 4\pi \cdot \frac{e}{4\pi r^2} \cdot \frac{2\pi r}{T}$$

$$= \frac{2\pi e}{Tr}$$

Now, a current i flowing in the circle has magnetic field $\frac{2\pi i}{r}$ at the centre, and hence for the moving charge to have the same magnetic field at O as the current—

$$\frac{e}{T} = i.$$

Röntgen Rays.—It was suggested by Sir G. Stokes that since the Röntgen rays arise where the kathode rays strike a solid obstacle, the rays may consist of an electromagnetic pulse emitted at the instant of stopping the electron. Sir J. J. Thomson¹ calculated the energy radiated by the electron on being stopped, and found that the greater the velocity of the electron, and the more sudden the process of stoppage, the greater is the energy radiated. Hence the greater penetrating power of the Röntgen rays from a “hard” vacuum tube, that is one of very high vacuum, with consequent large difference of potential between the electrodes and high velocity produced in the electrons. The case in which the velocity of the electron approaches that of light presents many difficulties, not the least being that the Faraday tubes are no longer uniformly distributed around the electron (p. 526).

When the velocity does not approach that of light we may easily calculate the rate of radiation of energy on stopping the electron. For let the electron at A (Fig. 440) be still moving with velocity v in the direction Ox , and let it be brought to rest in the space AB , the time occupied by the stopping being t . During this interval t the Faraday tubes at distances greater than Vt from the electron are still moving with the velocity v , and would be now diverging from the point C at which the electron would have arrived had it not been stopped. Then if $CF = Vt$ and $AC = vt$, the Faraday tube AG will, at the instant at

¹ J. J. Thomson, *Phil. Mag.*, 45, p. 172. 1898.

which stoppage is complete, have the shape BFK, where BF has a form depending on the manner in which stopping takes place. The kink BF in the Faraday tube will now travel along the tube with the velocity of light (p. 525). After a further interval of time t' , large compared with t , the shape of the Faraday tube will be BefN (Fig. 441), where ef is not necessarily a straight line; but the mean electric intensity over ef may be resolved into two components, one parallel to BM, the

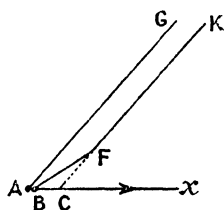

FIG. 410.

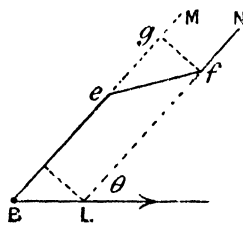

FIG. 441.

final position of the tube at rest, and the other parallel to gf , at right angles to BM . In the time t' the tube fN has moved forwards through the distance $BL = vt'$, and

$$gf = BL \sin \theta = vt' \sin \theta,$$

whereas the pulse has travelled a distance $Vt' = r$ along the tube.

Hence,—
$$\frac{\text{component parallel to } gf}{\text{component parallel to } eg} = \frac{gf}{eg} = \frac{vt' \sin \theta}{\delta},$$

where δ is equal to eg , the radial thickness of the pulse,

$$\therefore \text{component parallel to } gf = \frac{e}{r^2} \cdot \frac{vt' \sin \theta}{\delta},$$

since $\frac{e}{r^2}$ is the electric intensity at distance r from B .

$$\begin{aligned} \therefore \text{electric displacement } D, \text{ parallel to } gf &= \frac{e}{4\pi r^2} \cdot \frac{vt' \sin \theta}{\delta} \\ &= \frac{ev \sin \theta}{4\pi r V \delta} \end{aligned}$$

since $r = Vt'$ and $D = \frac{E}{4\pi}$.

This displacement is travelling at right angles to itself with velocity V , and the corresponding magnetic field at right angles to it, and to its velocity, is (p. 415)—

$$H = 4\pi D \cdot V = \frac{ev \sin \theta}{r\delta}.$$

Now, by Poynting's theorem (p. 417) the flux of energy for the two fields at right angles to each other is $\frac{HE}{4\pi}$, which in this case is—

$$\frac{1}{4\pi} \cdot \frac{ev \sin \theta}{r\delta} \cdot \frac{ev \sin \theta}{rV\delta} = \frac{e^2v^2 \sin^2 \theta}{4\pi r^2\delta^2 V}.$$

Since this is the rate at which energy is streaming past any point, the energy per unit volume at the point is obtained by dividing by the velocity, and is therefore $\frac{e^2v^2 \sin^2 \theta}{4\pi r^2\delta^2 V^2}$.

Thus we see that the energy radiated in the form of a pulse is proportional to the square of the velocity v destroyed on stoppage, and inversely as the square of thickness of the pulse. The time of passage of a pulse over any point varies directly as δ , the thickness of the pulse, and the rate of passage of energy varies as $\frac{1}{\delta^2}$, and hence the total energy radiated is greater for a thin pulse than for a thick one. Since the pulse is thinner the more abruptly the electron is brought to rest, it follows that more energy is radiated when the stoppage is sudden than when it is gradual.

Charge moving with Velocity of Light.—When the velocity v is that of light, we have seen (p. 527) that the field is confined to a plane of intense electromagnetic field passing through the electron and at right angles to the direction of motion. In this case, the sheet continues to travel onwards with the velocity of light after the electron is stopped, and the Faraday tubes grow outwards from the stopped electron at the same velocity. In order to follow this process, let us first consider the case of an electric charge suddenly jerked into motion with the velocity of light. Heaviside¹ has shown that, in this case, a spherical electromagnetic wave travels outwards from the point and annihilates the original distribution as it goes. We can see that this will be the case, for if the electric charge at O (Fig. 442) be suddenly jerked into motion, the tube whose original direction is OBCD is suddenly kinked into the shape ABCD, the kink B now travelling outwards with the same velocity V as that of the charge, now at A. Also, every part of the tube AB travels *with the same velocity* at right angles to itself, so that every part of it at a given instant must be at the same distance from O; that is, the form of the affected part of the tube as it spreads out is circular. After an interval of time t the charge is at F, where $OF = Vt$, and the

¹ O. Heaviside, *Electromagnetic Theory*, vol. 1.

grows. The energy required for the pulse and the re-establishment of the steady field is derived from the work done in stopping the electric charge. For subsequent knowledge of X rays see p. 562.

Origin of γ Rays.—It is at least probable that the γ rays emitted by radioactive materials have their origin when the β particles are liberated from the atoms. Whenever an electric charge acquires or loses velocity in a given direction, an electromagnetic pulse arises from it, and if the Röntgen rays are produced on the stopping of an electron it is likely that the starting of one would also give rise to a pulse. This hypothesis gains probability from the fact that when the β and γ rays are emitted in radioactive processes in which they are produced, they occur together.

Also, whenever Röntgen rays are absorbed, ionisation occurs. This may easily be explained if the rays consist of intense thin electromagnetic pulses, for an atom which may be supposed to consist of one or more negative electrons associated with a positively charged

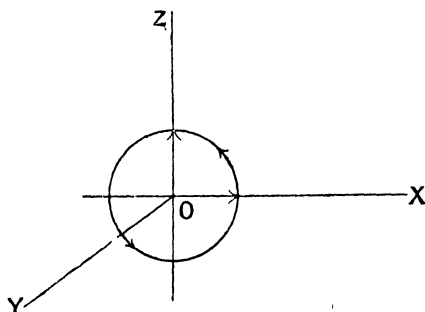

FIG. 444.

remainder, will experience a sudden and violent distortion as one of these pulses passes it, the electron being driven, while the great electric intensity lasts, in the opposite direction to the positive charge. Even though the electron may not be torn out of the atom, the stability of the latter may be destroyed, with ultimate liberation of the electron, and it may easily be understood that a succession of pulses

will have more ionising effect than a single one, as the later ones find the atom in a disturbed condition owing to the passage of the earlier ones.

Zeeman Effect.—We have already seen that when the velocity of an electric charge is changed, that is, when it has an acceleration, an electromagnetic pulse is radiated from it. Now a charge moving uniformly in a circle is continuously accelerated towards the centre, and hence we should expect a continuous emission from it.

If the circular motion be resolved into two simple harmonic components parallel to OX and OZ (Fig. 444), the motion parallel to OX means a lateral displacement of the ends of those Faraday tubes which are parallel to OZ and OY , and hence disturbances travel in these directions. Similarly, the motion parallel to OZ causes waves to travel in the directions OX and OY . In the direction OY , the corresponding waves would at each point be represented by a rotating electric displacement, consisting of the two harmonic displacements, of which one is 90° in phase ahead of the other.

If the periodicity of the rotation of the charge is equal to that of light waves, the electromagnetic waves emitted are in all probability waves constituting light, and according to the electronic theory of Larmor and H. A. Lorentz light is due to the rotations of electrons within the atom. So long as these orbital motions of the electrons are undisturbed, it is extremely difficult to put the theory on an experimental basis, but the discovery of Zeeman¹ in 1896 that the light emitted by incandescent sodium vapour is modified by a magnetic field, supplied the necessary evidence. If a sodium burner be placed between the poles of a powerful electromagnet, and the emitted light analysed by means of a spectroscope, the D lines of sodium are both broadened, and if the resolving power be sufficient, are split up into several components. When the light is received in the direction of the magnetic field, having passed through a hole bored longitudinally through the pole pieces of the magnet, there are two components of the line, and these are found to be circularly polarised in opposite directions. When the light leaves the flame in a direction at right angles to the magnetic field there are three components; the middle one, which occupies the undisturbed position of the line, is plane polarised, the direction of the electric displacement being parallel to that of the magnetic field, and the outer two are also plane polarised, but in a direction at right angles to the first.

These results are in accordance with the theory, and in the cases in which they are of the form described, the simple explanation given by Lorentz² suffices. In most cases, the behaviour of the spectral lines is more complicated, but the complete theory of Lorentz still accounts for the facts.

Consider all the atoms concerned in the emission of light; their rotations may all be resolved into simple harmonic vibrations along the three rectangular axes OX, OY, and OZ (Fig. 445). Those parallel to OY give rise to waves (*a*) spreading out in the plane ZO \bar{X} , with direction of electric displacement parallel to OY, but not to waves travelling in the direction OY. The vibrations parallel to OZ and OX may, for convenience, be considered to be compounded into two equal and opposite rotational movements, which will give rise to plane polarised waves (*b*) in the plane ZO \bar{X} , and to two circularly polarised waves, one of which is shown at *c*, travelling in the direction OY.

If now the magnetic field be in the direction OY, the vibration of the electric charge in this direction is unchanged, as are the waves (*a*). But the charges rotating in the circular paths are moving at right angles to the magnetic field, and consequently will experience forces of value Hev at right angles to their motion and to the field, the force on one being directed away from O, and on the other towards O. Assuming that the electron is subject to a restoring force acting towards the centre O of the atom and proportional to its distance *r* from O, there

¹ P. Zeeman, *Phil. Mag.*, 43, p. 226. 1897.

² H. A. Lorentz, *Rapports au Congrès Internationale de Physique*, 3, 1900.

is equilibrium without the magnetic field when the centrifugal force $\frac{mv^2}{r}$ is equal to the restoring force fr , f being the restoring force for unit displacement, and m the mass of the electron. If T be its period of vibration,

$$v = \frac{2\pi r}{T},$$

$$\therefore \frac{4\pi^2 r m}{T^2} = fr, \text{ or, } \frac{4\pi^2 m}{T^2} = f.$$

Now, the presence of the magnetic field produces a radial force Hev , and the restoring force fr must be increased or diminished by this

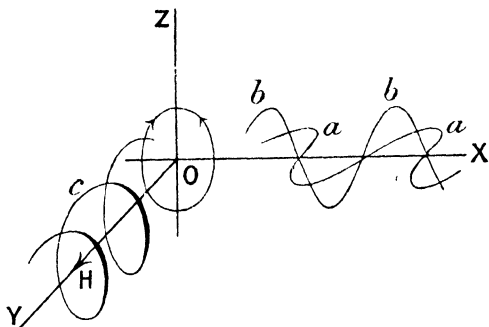

FIG. 445.

amount according to the direction of rotation and the sign of the charge.

If then T_1 be the period of rotation in the magnetic field,

$$\frac{4\pi^2 r_1 m}{T_1^2} = fr_1 \pm Hev_1,$$

or,
$$\frac{4\pi^2 m}{T_1^2} = f \pm \frac{Hev_1}{r_1}, \quad \text{and since, } f = \frac{4\pi^2 m}{T^2},$$

$$\frac{4\pi^2 m}{T_1^2} - \frac{4\pi^2 m}{T^2} = \pm \frac{2\pi He}{T_1},$$

$$\therefore \frac{1}{T_1^2} - \frac{1}{T^2} = \pm \frac{He}{2\pi m T_1},$$

$$\frac{T^2 - T_1^2}{T^4} = \pm \frac{He}{2\pi m T_1},$$

$$T - T_1 = \pm \frac{HeT^2}{4\pi m} \dots \dots \dots (i)$$

if T^2 be written for T_1T and $2T$ for $T + T_1$, both of which are justifiable when the changes in the periodic time produced by the magnetic field are small in comparison with T itself. Equation (i) may be written in terms of wave lengths λ if we remember that $\lambda = VT$, and then becomes —

$$\lambda - \lambda_1 = \pm \frac{He\lambda^2}{4\pi mV} \dots \dots \dots (ii)$$

The periodic times of the two circular motions are therefore changed, one being diminished by the amount $\frac{HeT^2}{4\pi m}$, and the other increased by the same amount, and since each gives rise to a plane wave (*b*) we should expect there are two such waves emitted, one having greater frequency and the other less frequency than the undisturbed wave (*a*). Thus in the case of the light emitted at right angles to the magnetic field, the single spectral line becomes a triplet, the central part being plane polarised with its electric displacement parallel to the magnetic field, and the two, one on either side of it, being plane polarised in a direction at right angles to this.

The light emitted in the direction of the magnetic field gives rise to a doublet, each component of which is circularly polarised. By means of a quarter-wave plate each of these circularly polarised rays can be rendered plane polarised, but the direction of the electric displacement depends upon the direction of rotation in the circularly polarised beam. With the direction of magnetic field given in Fig. 445, it is found that the anticlockwise rotation, as seen on looking at the diagram, gives rise to the line displaced towards the blue end of the spectrum, and hence, applying the left-hand law (p. 239), we see that the rotating charge which gives rise to the light rays has the negative sign.

It is only when the vibration of the electron within the atom is of the simple harmonic type that we should expect the simple separation of the components of any spectral line described above. In nearly all cases the decomposition is into a much greater number of lines, but our explanation would show us that the light emitted at right angles to the field should always give plane polarised components, and the light along the direction of the field to oppositely circularly polarised components, and this is found to be the case. Moreover, whatever be the complexity of the resolved spectral line, the separation of the most widely separated components is a constant quantity.

According to Runge and Paschen,¹ for the normal triplet in the spectrum of mercury vapour, the quantity $\frac{\lambda_1 - \lambda_2}{\lambda^2}$, where λ_1 and λ_2 are the wave lengths of the displaced lines, was found to have the

¹ C. Runge and F. Paschen, *Abhandl. der Berl. Akad.*, 1902.

value 2.14 when the strength of magnetic field was 24,600. Hence, from equation (ii)—

$$\frac{\lambda_1 - \lambda_2}{\lambda^2} = \frac{H}{2\pi V} \cdot \frac{e}{m} = 2.14,$$

$$\text{or,} \quad \frac{e}{m} = \frac{2\pi \times 2.14 \times V}{H} = \frac{6.28 \times 2.14 \times 3 \times 10^{10}}{24,600} \\ = 1.6 \times 10^7.$$

Now, the value of $\frac{e}{m}$ for the kathode rays is 1.77×10^7 (p. 488), and hence it is extremely likely that the constituent of the atom whose motion gives rise to the emission of light is the electron met with in the kathode rays and in the β rays emitted by radioactive substances.

Dielectric Constant and Refractive Index.—The presence of atoms each consisting of some framework in which one or more electrons are situated, may be used to explain many of the physical properties of matter. The neutral atom has no resultant electric charge, but if it loses an electron, its resultant charge is positive. We know very little about the atom, apart from the fact that it contains and is capable of losing at least one unit of electrical charge, the electron, which is equivalent to about 1.57×10^{-20} electromagnetic C.G.S. units of charge. We may then draw a distinction between dielectrics or insulators on the one hand and conductors on the other; the former is a substance in which the electrons are displaceable within the atom, but are not detachable from it, while in the latter the electrons can be detached from the atoms, and are free to move in the spaces between them.

If f be the restoring force for unit displacement, and x the actual displacement of an electron from its neutral position, the restoring force is fx , and this is equal to the force Ee due to the electric field producing the displacement.

That is, $Ee = fx$.

Within a mass of the material in which there are N atoms per unit volume, the component of the electric displacement due to one atom in each unit of volume being ex , that due to the N atoms is Nex . That corresponding to the original field is $\frac{E}{4\pi}$ (p. 130), and hence the total electric displacement D within the material is the sum of the two quantities Nex and $\frac{E}{4\pi}$.

$$\therefore D = \frac{E}{4\pi} + Nex, \\ 4\pi D = E + 4\pi Nex$$

$$= E + \frac{4\pi N E e^2}{f}$$

$$= E \left(1 + \frac{4\pi N e^2}{f} \right).$$

Now, the dielectric constant $k = \frac{4\pi D}{E}$ (p. 130),

$$\therefore k = 1 + \frac{4\pi N e^2}{f}.$$

Remembering that the refractive index $n = \frac{V_0}{V}$, where V_0 is the velocity of light in vacuo and V is the velocity in the medium, and further that—

$$V_0 = \frac{1}{\sqrt{k_0 \mu_0}} \quad \text{and} \quad V = \frac{1}{\sqrt{k \mu}},$$

we see that—

$$n = \sqrt{\frac{k \mu}{k_0 \mu_0}}.$$

Now, for most substances μ is practically equal to μ_0 , and if $k_0 = 1$ for vacuum—

$$n = \sqrt{k}, \text{ or, } n^2 = k.$$

Hence,
$$n^2 - 1 = \frac{4\pi N e^2}{f}.$$

In the case of a gas N is proportional to the density, and since the atoms are at considerable distances from each other, f is independent of the density,

$$\therefore n^2 - 1 \propto \text{density}.$$

On p. 422 we saw that for gases $k = n^2$. It was shown by Boltzmann¹ that the quantity $k - 1$ is proportional to the pressure and therefore to the density of the gas. It should be noted that any theory which supposes the electric displacement within a dielectric to be due to the presence of small conducting bodies will lead to the above result.

Refraction and Dispersion.—Many theories have been advanced to account for the phenomena of the refraction and dispersion that occur as light passes from one medium to another. The mechanical theories, notably those of Fresnel and MacCulloch, afterwards modified by Sellmeier, account in a more or less satisfactory manner for the observed facts. But the electronic theory of H. A. Lorentz not only accounts for these same facts, but has the great advantage that it is in accordance with phenomena occurring in other branches of physics. As

¹ L. Boltzmann, *Wien. Ber.*, 69, 1874.

an example, we may cite the fact that the value of $\frac{e}{m}$ for the electrons concerned in the emission of light, as measured by the Zeeman phenomenon, is nearly identical with that found for the electrons in the cathode and the β rays. The mechanical theories suffered from the difficulty that it was almost impossible to reconcile the necessary properties of the incompressible aether with those of any known material substance.

On p. 431 we explained the reflection of electromagnetic waves from the surface of a conductor on the supposition that the electric intensity within the conductor is always zero. The reason for this last fact is clear, on the assumption that within the conductor free electrons exist which travel in a direction determined by that of the electric intensity.

If in Fig. 372, p. 431 the incident electrical intensity is directed upwards, and therefore on account of it the free electrons travel downwards, since their charges are negative, and the electric intensity due to them in their displaced position is directed downwards, that is, in opposition to the incident intensity. By their motion, as the harmonic wave arrives, they supply the equal and opposite harmonic variations of intensity which give rise to the two waves, one of which is the reflected wave, and the other a wave propagated into the conductor, and whose condition is everywhere equal and opposite to that of the incident wave, so that the two together have a zero resultant effect.

If the electrons are subject to some constraint, their motion will involve the expenditure of energy, and the reflection is not in this case perfect. For the best conductors known, the energy of the reflected beam is not quite equal to that of the incident beam. When the electrons are not free to move there will then be no reflection; the medium is perfectly transparent. No such substance is known; a certain amount of reflection always occurs as light passes from a vacuum to a material substance. But in the case of dielectrics, the electrons, although free to move within the atom, are confined to the atoms, and it is only in the case in which their own proper periods of vibration within the atom approach that of the incident wave that any considerable amount of reflection occurs. The reflection in this case, although powerful, differs from the case of metallic reflection, in that only those waves having periodicity nearly equal to that of some particular free vibration of the electron within the atom are reflected.

Let us imagine that for a given substance the periodic time T_1 of the free vibrations of the electron within the atom is given by the equation $T_1 = 2\pi\sqrt{\frac{m}{f}}$, and let electromagnetic waves for which the electric intensity in the plane of incidence is $E = E_0 \sin 2\pi\frac{t}{T}$, fall upon the substance.

If x be the displacement of the electron from its position of equilibrium, the restoring force due to this is fx , and if the disturbing force due to the incident wave is Ee , the resultant force acting on it is $fx - Ee$, and the equation of motion of the electron is—

$$m \frac{d^2x}{dt^2} + fx - Ee = 0 \quad (\text{p. 22}),$$

or,
$$m \frac{d^2x}{dt^2} + fx = eE_0 \sin pt,$$

where,
$$\frac{2\pi}{T} = p,$$

$$\therefore \frac{d^2x}{dt^2} + \frac{f}{m}x = \frac{e}{m} \cdot E_0 \sin pt.$$

Whatever its motion when the light is first incident upon it, it will after a few oscillations settle down to a steady vibration with the periodicity of the incident waves, and our problem is to find the amplitude of this vibration. The most general equation for this vibration is,—

$$x = A \sin pt + B \cos pt,$$

where A and B are constants, at present unknown.

Hence,
$$\frac{dx}{dt} = Ap \cdot \cos pt - Bp \sin pt,$$

$$\frac{d^2x}{dt^2} = -Ap^2 \sin pt - Bp^2 \cos pt,$$

and substituting the values for $\frac{dx}{dt}$ and x in the equation of motion, we have—

$$-Ap^2 \sin pt - Bp^2 \cos pt + \frac{f}{m}A \sin pt + \frac{f}{m}B \cos pt = \frac{e}{m} E_0 \sin pt.$$

This equation must be satisfied for all values of t . Now, when $pt = \frac{\pi}{2}$, $\cos pt = 0$ and $\sin pt = 1$,

$$\therefore -Ap^2 + \frac{f}{m}A = \frac{e}{m} E_0,$$

and when $t = 0$, $\sin pt = 0$ and $\cos pt = 1$.

$$\therefore -Bp^2 + \frac{f}{m}B = 0.$$

It follows that, except when $p^2 = \frac{f}{m}$,

$$B = 0, \text{ and, } A = \frac{\frac{e}{m} E_0}{\frac{f}{m} - p^2}.$$

Therefore the equation—

$$x = \frac{\frac{e}{m} E_0}{\frac{f}{m} - p^2} \sin pt$$

expresses the motion of the electron.

Now, $p = \frac{2\pi}{T}$, and, $\frac{f}{m} = \frac{4\pi^2}{T_1^2}$;

$$\therefore x = \frac{e}{m} \cdot \frac{E_0}{4\pi^2 \left(\frac{1}{T_1^2} - \frac{1}{T^2} \right)} \sin pt.$$

The amplitude of vibration of the electron is therefore

$$\frac{e}{m} \cdot \frac{E_0}{4\pi^2 \left(\frac{1}{T_1^2} - \frac{1}{T^2} \right)}, \text{ or, } \frac{e}{m} \cdot \frac{E_0}{4\pi^2 (n_1^2 - n^2)},$$

where n_1 and n are corresponding frequencies.

We see, then, that when n_1 is very great, the amplitude of vibration due to the incident wave is infinitesimal, which means that if the electron is practically immovable, its presence does not affect the propagation of the wave. But if n_1 approaches in value to n , the amplitude increases and would, if our equation truly represented the facts, become infinite when $n_1 = n$, which therefore corresponds to an ordinary case of resonance. We have, however, neglected all resistance to the motion of the electron, so that our result does not represent the truth when $n = n_1$.

The reasoning on p. 536 will enable us to see the effect which, according to the electronic theory, this motion of the electrons will have upon the refractive index of the material.

Putting $D_0 \sin pt$ in place of D , $E_0 \sin pt$ in place of E , and

$$\frac{\frac{e}{m} E_0}{4\pi^2 \left(\frac{1}{T_1^2} - \frac{1}{T^2} \right)} \sin pt \text{ in place of } x \text{ in the equation } 4\pi D = E + 4\pi N e x,$$

and dropping the term $\sin pt$ throughout, we have—

$$4\pi D_0 = E_0 + 4\pi \frac{Ne^2}{m} \cdot \frac{E_0}{4\pi^2 \left(\frac{1}{T_1^2} - \frac{1}{T^2} \right)},$$

or

$$k = 1 + \frac{Ne^2}{\pi m \left(\frac{1}{T_1^2} - \frac{1}{T^2} \right)} = n^2,$$

This may be expressed in terms of wave lengths instead of periodic times, if by λ_1 we mean the wave length in vacuo which corresponds to the periodic time T_1 . Then $\lambda_1 = VT_1$ and $\lambda = VT$, so that—

$$n^2 = 1 + \frac{Ne^2\lambda_1^2}{\pi m V^2} \cdot \frac{\lambda^2}{\lambda^2 - \lambda_1^2} \dots \dots \dots \text{(iii)}$$

where n is the index of refraction for the waves.

This equation will of course only represent the facts when the atoms are so far apart that the free period of the electron is not affected by the presence of neighbouring atoms, and when there is only one free period of oscillation. In the case of most substances, we have evidence of a great number of free periods, since each line in the spectrum of the light emitted is due to one such period.

The reason for the dispersion of light as it enters a refracting medium is now apparent, for the index of refraction depends upon the wave length λ of the incident disturbance. When λ is very great in comparison with λ_1 , the last equation becomes

$$n^2 = 1 + \frac{Ne^2\lambda_1^2}{\pi m V^2},$$

which is the refractive index for very long waves. Since $\lambda_1 = VT_1$ and $T_1 = 2\pi\sqrt{\frac{m}{f}}$, we see that this is the value found for n^2 on p. 537.

As λ approaches the value λ_1 , the denominator of the last term in equation (iii) varies rapidly, and the value of n increases, becoming enormous when $\lambda = \lambda_1$. The curve AB in Fig. 446 indicates the manner in which n^2 varies as λ approaches λ_1 , for a case in which n^2 is 1.25, when λ diminishes from infinity, and $\lambda_1 = 6 \times 10^{-5}$. When $\lambda < \lambda_1$ the sign of

$\frac{\lambda}{\lambda^2 - \lambda_1^2}$ changes, and the denominator increases while the numerator decreases. As therefore λ decreases, the value of n^2 increases from a large negative value, until when $\lambda = 0$, $n = 1$. This is indicated by the curve EF. Hence, for light waves of extremely short length the refractive index approaches the value unity.

In the case of a substance for which the electron has one free period of vibration, light waves of this period are strongly reflected, and hence the spectrum of the light transmitted by the substance exhibits an

absorption band in this part of the spectrum; and, further, the light of this wave length is that which will be emitted when the temperature is raised sufficiently for the body to be visible. This is a well-known result of Kirchhoff's laws of radiation.

When the light absorbed has a much higher frequency than the visible rays, the refraction is "normal," as in the case of glass, etc., the waves of greater frequency being refracted most. The curve for n^2 and λ lies upon the part of AB (Fig. 446) remote from the origin. If, however, the absorption band occurs in the visible part of the

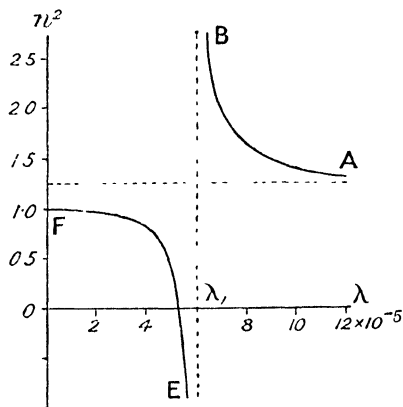

FIG. 446.

spectrum, the two parts on either side of the band change places, the red part being refracted more than the blue, although in each part the natural order of the colours is preserved. The dispersion is then usually said to be "anomalous." Those substances, such as the aniline dyes, which have a strong absorption band in the visible part of the spectrum, exhibit the phenomenon of "anomalous" dispersion, and Professor R. W. Wood¹ has shown in a beautiful manner that this also occurs in the case of a prism of sodium vapour.

Faraday Effect.—Some connection between magnetism and light was suspected by Faraday, but the only connection which he was able to find was that the plane of polarisation of a beam of light passing through a dense transparent medium, such as a dense lead glass, experienced a rotation when the ray travels along the magnetic lines of force. On boring holes longitudinally through the poles of a powerful electromagnet, and passing a beam of light, plane polarised by means of a Nicol's prism, through these holes in such a way that it traverses a block of dense lead glass situated between the poles, it is found that the position of a second Nicol's prism, used as analyser to produce extinction of the beam, depends upon whether the magnetic field is on or off.

This phenomenon, known as the Faraday effect, bears some resemblance to the rotation of the plane of polarisation when a beam of light passes through certain crystallised media, such as quartz, in a direction parallel to the optic axis; but there is one great difference between the two cases. In the crystal, the rotation of the plane of polarisation depends in some way upon the crystalline structure of the

¹ R. W. Wood, *Roy. Soc. Proc.*, 69, p. 157. 1901.

medium, and if on emergence the beam be reflected back so that it retraverses the crystal in the opposite direction, the opposite rotation occurs, and the beam emerges with its original direction of polarisation. But in the Faraday effect the direction of rotation is fixed in relation to that of the magnetic field, whatever be the direction of propagation of the beam, so that if the beam be caused to retrace its path through the field, the rotation of the plane of polarisation is doubled.

The rotation of the plane of polarisation depends upon the presence of the material medium in the magnetic field, and according to the electronic theory we can easily see why this should be. On p. 541 we saw that the index of refraction depends upon the free period of vibration of the electrons within the atom, and again on p. 534 we saw that the natural period of rotation of the electrons changes in the presence of a magnetic field, and also depends upon the direction of rotation.

Consider a plane polarised beam of light falling upon the block of dense glass; in the absence of a magnetic field, the orbits of rotation of the electrons are circles, the two components of the motion at right angles to the direction of propagation being of equal frequency and clockwise and anti-clockwise respectively (see Fig. 445). We may, if we please, consider the plane vibration constituting the beam of light to be resolved into a clockwise and an anti-clockwise circular vibration, the relative phases of which determine the plane of polarisation (p. 375). These travel with equal velocities through the medium since the refractive index is modified by the electrons to the same extent for both components, and on emergence they are in the same relative phases as on entrance, and combine to form a plane polarised beam with its plane of vibration in the original direction.

If, however, there is a magnetic field, the electronic orbits are modified, one periodic time being increased and the other diminished (p. 534), and the refractive indices for the two components of the beam are now different (p. 541). Hence they differ in phase on emergence by an amount depending upon the length of path in the medium and the strength of the magnetic field, and will combine into a plane polarised beam, whose plane of vibration is rotated from the original plane by an amount proportional to the difference of phase between the two circularly polarised components.

The rotation of the plane of polarisation was measured by Verdet for various substances and wave-lengths of light, and was found by him to fit the formula—

$$\theta = m l H \frac{n^2}{\lambda} \left(n - \lambda \frac{dn}{d\lambda} \right),$$

where l is the length of path traversed in the field, λ the wave-length in air of the light used, n the index of refraction, and m a constant depending upon the medium.

The quantity $\frac{\theta}{IH}$, or the rotation produced by travelling unit distance in unit field, is called Verdet's constant.

The following are a few of the values of Verdet's constant :—

	Minutes of arc.	
Jena glass (densest silicate flint) .	0.0888	(Du Bois, <i>Wied. Ann.</i> , 51 , 1894)
Quartz	0.01664	(Borel, <i>Arch. Genève</i> , (4), 16 , 1903)
Methyl alcohol	0.00989	(Quincke, <i>Wied. Ann.</i> , 24 , 1885)
Water	0.01311	(Roger and Watson, <i>Zeitsch. Phys. Chem.</i> , 19 , 1896)

Kerr Effect.¹—It was found that plane polarised light, on being reflected from the polished pole of an electromagnet, was rendered elliptically polarised, and also that a transparent medium becomes slightly doubly refracting in a strong electrostatic field.²

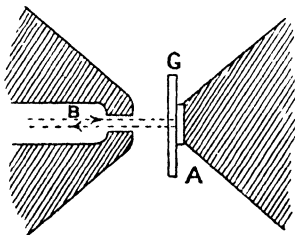

FIG. 447.

The Faraday and Kerr effects have been used by Du Bois³ to measure strong magnetic fields and high intensities of magnetisation. A polished plate A (Fig. 447) of the metal under examination is placed on the flattened tip of the pole-piece of an electromagnet, and the plane polarised beam of light which traverses the hole B in the other pole of the magnet is reflected at A and returns along its own path. The rotation of the plane of polarisation is proportional to the intensity of magnetisation of A, the constant coefficient having been previously determined. The magnetising field is measured by placing a sheet of glass G, with its back surface silvered, to reflect the beam of light as before. From a knowledge of the rotation of the plane of polarisation and the value of Verdet's constant for the material, the strength of the magnetic field is known.

Paramagnetism and Diamagnetism.—The electronic theory has been adapted by Langevin⁴ to account for the magnetic properties of materials. An electron rotating in a circular orbit is equivalent to a circular current, and corresponds very well to the hypothetical molecular currents of Ampère. Most atoms include many electrons, and the orbits of these may be so directed that the resultant magnetic moment for the atom is zero. In this case a magnetic field would not

¹ J. Kerr, *Phil. Mag.*, **3**, p. 32 (1877); and **5**, p. 116 (1878).

² J. Kerr, *Phil. Mag.*, **50**, p. 337. 1875.

³ H. E. J. G. du Bois, *Phil. Mag.*, **29**, p. 293. 1890.

⁴ P. Langevin, *Comptes Rendus*, **140**, p. 1171. 1905.

have any directive effect upon the atom. When, however, the resultant magnetic moment of the atom is not zero, either by reason of one electron uncompensated by another rotating in the opposite direction, or for any other reason, the atom would be rotated into such a direction that there is an increase in the magnetic induction. That is, the permeability of the substance is greater than unity and its magnetic susceptibility is positive. Substances of this kind are said to be *paramagnetic*. The susceptibility is always comparatively small, as in the case of aluminium, platinum, etc. (p. 458). There is one small class of metals, iron, nickel, and cobalt, in which the magnetic permeability is vastly greater than for any other substance. These are said to be the *ferromagnetic* metals, and their strong magnetic properties are probably due to the fact that the neighbouring atoms, of the paramagnetic kind, have sufficient influence upon each other to form larger groups, which are then influenced by the magnetising field. When the resultant magnetic moment of each atom is zero, the magnetising field will still have some effect, owing to its influence upon the electronic orbits themselves. The effect will be to decrease the magnetic induction, as shown below. Thus the magnetic permeability is less than unity, and the susceptibility is negative. Such substances are said to be *diamagnetic*, as, for example, copper and gold (p. 548), antimony and bismuth (p. 549).

It is quite reasonable, therefore, to suppose that there are two opposite processes going on when a substance is placed in a magnetic field, the resulting susceptibility being a measure of the difference of the two. The orientation of the orbits into a direction which will cause an increase in the magnetic induction is the first, and gives rise to paramagnetic properties. To understand the second we may refer to a theory suggested by Weber and developed by Maxwell in his "Electricity and Magnetism." If the molecule of the material be an electrical conductor, the establishment of a magnetic field will cause a current to flow in it. Let the circle AB (Fig. 448) be a line of flow of such a current within a molecule, OH being the direction of the magnetic field. While the field is becoming established, this current is clockwise, as seen in the diagram, and hence the magnetic field within it, due to its own presence, is in the opposite direction to the original field. The magnetic induction is thus reduced by the presence of the conducting molecule, and the presence of such conducting molecules would give to the material the diamagnetic property. If its electrical resistance be zero, the current, once started, will continue to flow until, on the removal of the magnetising field, an opposite induced electromotive force reduces the current to zero.

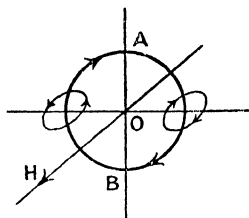

FIG. 448.

If now we replace the conducting molecule of Weber and Maxwell

by the atom with its rotating electrons, we can explain the para- and diamagnetism. For the rotation into the direction of the field increases the magnetic induction within the material; and we will now proceed to show that the alteration in the orbits produced by the magnetising field reduces the induction. The material will then be para- or diamagnetic according to which effect is the greater.

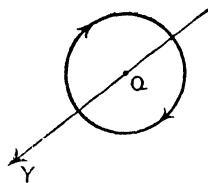

FIG 449.

For a mass of the material, the possible motions of the electrons may all be resolved, as described on p. 533, into a linear vibration along one axis OY (Fig. 445) and two equal and opposite circular rotations in a plane at right angles to this. Let the magnetising field H be in the direction OY; then the linear vibration along this axis is unaffected by the field, but the circular motions are affected as already described. For the rotation of the electron shown by the arrow in Fig. 449, the equivalent current is in the opposite direction, since the electron is a negative charge; the force due to the field is Hev and is directed outwards along the radius, and hence, as on p. 534—

$$\begin{aligned} \frac{mv_1^2}{r_1} &= fr_1 - Hcv_1, \\ \text{or,} \quad \frac{4\pi^2}{T_1^2} - \frac{f}{m} &= -\frac{He}{m} \cdot \frac{2\pi}{T_1} \dots \dots \dots (a) \end{aligned}$$

Now, for the rotation of the electron in the opposite direction, the force due to the magnetic field is directed inwards, that is towards O,

$$\begin{aligned} \therefore \frac{mv_2^2}{r_2} &= fr_2 + Hcv_2, \\ \text{or,} \quad \frac{4\pi^2}{T_2^2} - \frac{f}{m} &= +\frac{He}{m} \cdot \frac{2\pi}{T_2} \dots \dots \dots (b) \end{aligned}$$

Subtracting equation (b) from (a), we have—

$$\begin{aligned} \frac{1}{T_1^2} - \frac{1}{T_2^2} &= -\frac{He}{2\pi m} \left(\frac{1}{T_1} + \frac{1}{T_2} \right), \\ \therefore \frac{1}{T_1} - \frac{1}{T_2} &= -\frac{He}{2\pi m} \dots \dots \dots (c) \end{aligned}$$

Again, we saw on p. 528 that a charge e moving in a circular orbit in periodic time T is equivalent to a circular current $\frac{e}{T}$, and hence the magnetic moment of such an orbit is $\frac{ea}{T}$, where a is the area of the circle. If there are N_1 such orbits per unit volume of the material,

$\frac{N_1 e a}{T}$ is the magnetic moment, or the intensity of magnetisation due to them. When the magnetising field is zero, the magnetic moment due to the electrons rotating in either direction is $\frac{N_1 e a}{T}$, and these being oppositely directed, the resulting intensity of magnetisation is zero. In the presence of the magnetic field, the magnetic moment due to the electrons rotating as shown in Fig. 449 is $\frac{N_1 e a}{T_1}$, and is directed from O to Y; that due to the opposite rotations is $\frac{N_1 e a}{T_2}$, and is directed from Y to O.

From equation (c)—

$$\frac{N_1 e a}{T_1} - \frac{N_1 e a}{T_2} = - \frac{N_1 H e^2 a}{2 \pi m},$$

the left-hand side of which equation is the resultant intensity of magnetisation directed from O to Y, and the right-hand side shows us that this is always negative, and hence that the magnetisation is in the opposite direction to the magnetising field. Also the ratio of intensity of magnetisation to magnetising field is the magnetic susceptibility k ,

$$\therefore k = - \frac{N_1 e^2 a}{2 \pi m}.$$

In this case N_1 is not the total number of rotating electrons in unit volume of the material. If we imagine all the rotating electrons to be divided into six groups having for their axis of rotation the three rectangular axes respectively, the two rotations about any axis being opposite, only those having axes parallel to the magnetic field have any magnetic moment in this direction, and therefore only two out of the six groups, that is one-third of the total number of rotating electrons present, are concerned in determining the susceptibility. Hence, if N is the total number present,

$$N_1 = \frac{N}{3},$$

and,

$$k = - \frac{N e^2 a}{6 \pi m}.$$

The above value of the susceptibility is calculated on the assumption that the electronic orbits are not rotated by the magnetic field so that their axes become parallel to the field and produce magnetisation in the direction of the field. If all the electronic orbits were rotated in this way the intensity of magnetisation would be $+\frac{N e a}{T}$, this value corresponding to saturation. This is the limiting value of the intensity of

magnetisation of a paramagnetic material. It should be noticed that there is no limiting value to the diamagnetisation of a material, for the intensity of magnetisation $-\frac{NHe^2a}{6\pi m}$ is proportional to the magnetising field.

We see, then, that the property of diamagnetism is the result of effects occurring within the atom, and would therefore be independent of temperature. Such is found to be the case with most substances, antimony and bismuth being exceptions. Paramagnetism, on the other hand, we should expect to be influenced by temperature, since it is the orientation of the atom or molecule with which we are here concerned. If the opposite rotations of the electrons within the atom are symmetrical, the diamagnetic property only would be exhibited, but if unsymmetrical there would be a resultant magnetic moment with exhibition of paramagnetism, and if, further, the atoms affect each other and form groups, the material may then be ferromagnetic.

Weiss¹ found that for magnetite, increasing temperature was accompanied by sudden changes in the magnetic moment of the material, which changes were all multiples of one quantity. He concludes that all paramagnetic atoms contain a number of uncompensated electronic orbits, each constituting the ultimate unit of magnetic moment, just as the electron is the ultimate unit of electric charge. Weiss calls this the *magneton*. The magneton has a magnetic moment of about 16×10^{-22} C.G.S. units.

It was found by Curie² that the magnetic susceptibility referred to unit mass varies inversely as the absolute temperature in the case of the paramagnetic substances, and this is now known as Curie's law.

The quantity KT , where $K = \frac{k}{\text{density}}$, and T the absolute temperature,

is Curie's constant. In the case of oxygen, Curie found the magnetic susceptibility to be represented very well by the relation $10^6 K = \frac{33,700}{T}$,

and by measuring the force on small metallic spheres, first in air and then in liquid oxygen, Dewar and Fleming³ found the value of k for liquid oxygen to be 324×10^{-6} , or $\mu = 1.00407$.

In the following table are some of the magnetic constants for the elements found by Koenigsberger:⁴—

Aluminium	$k = +1.80 \times 10^{-6}$
Copper	-0.82×10^{-6}
Gold	-1.51×10^{-6}
Platinum	$+22 \times 10^{-6}$
Silver	-1.51×10^{-6}

¹ P. Weiss, *Comptes Rendus*, 152, pp. 79 and 187. 1911.

² P. Curie, *Journ. d. Phys.*, 4, p. 197. 1895.

³ J. Dewar and J. A. Fleming, *Proc. Roy. Soc.* 63, p. 311. 1898.

⁴ J. Koenigsberger, *Wied. Ann.*, 66, 698. 1898.

According to Curie,¹ we have—

Water from 15°–189° C. . . .	K =	– 0.790 × 10 ^{–6}
Quartz „ 18°–430°		– 0.441 × 10 ^{–6}
Sulphur „ 18°–225°		– 0.510 × 10 ^{–6}
Antimony at 20°		– 0.680 × 10 ^{–6}
„ „ 540°		– 0.470 × 10 ^{–6}
Bismuth (solid) at 20° C. . . .		– 1.350 × 10 ^{–6}
„ „ 273° C. . . .		– 0.957 × 10 ^{–6}
„ (fused) 273–405° C. . . .		– 0.038 × 10 ^{–6}

Temperature Equilibrium of Electrons.—We shall now consider briefly the theory of electrical conduction by means of free electrons, first suggested by Riecke² and more explicitly stated by Drude.³ Remembering the distinction we have drawn between electrical conductors and insulators, that in the latter the electrons are bound within the atom, whereas in the former some of them are free to leave the atom and therefore move under forces exerted by an electric field, we may, by assuming that these free ions obey the ordinary laws found for molecules in the kinetic theory of gases, obtain certain results which are in agreement with experimentally observed facts.

Let us consider for a moment the elementary form of the kinetic theory of gases. If a gas consist of N molecules per unit volume, which are entirely independent of each other, except that in their motions they will frequently collide, we may, as a first approximation, resolve all the molecular motions parallel to the three rectangular axes, and remembering that at any instant as many are moving parallel to an axis in its positive direction as in its negative direction, we can represent the indiscriminate motions of the molecules by dividing them into six groups of constant velocity, each moving in one particular direction parallel to one of the three axes. Thus we have $\frac{N}{6}$ molecules moving in one direction with say velocity v . A plane surface of unit area at right angles to this direction will therefore be struck by $\frac{Nv}{6}$ molecules per second. Each molecule has momentum $+mv$ before striking the surface and momentum $-mv$ on rebounding from it, so that the impulse at each rebound is $2mv$. Hence the pressure on the surface is $\frac{Nv}{6} \times 2mv$,

$$\text{or,} \quad p = \frac{1}{3} Nmv^2$$

Nm is the mass per unit volume of the gas, or its density, and since

¹ P. Curie, *Comptes Rendus*, 115, p. 803 (1892); and 116, p. 137 (1892).

² E. Riecke, *Wied. Ann.*, 66, pp. 353 and 545. 1898.

³ P. Drude, *Ann. der Physik.*, 1, p. 566 (1900); and 3, p. 369 (1900).

pressure \times volume = RT , where T is the absolute temperature, we see, since the volume is unity, that—

$$\frac{1}{3}Nmv^2 = RT.$$

If 1 gramme-molecule of the gas be taken, R is the universal gas constant, or 8.32×10^7 (p. 193), m is the mass of one molecule, and N the number of molecules in unit volume, which is the same for all gases at the same temperature and pressure.

$$\therefore \frac{1}{3}mv^2 = \frac{R}{N}T,$$

or,

$$\frac{1}{2}mv^2 = \frac{3}{2} \cdot \frac{R}{N}T.$$

Hence we conclude that for all gases in equilibrium, the absolute temperature is proportional to the mean kinetic energy of the molecules,

or,
$$\frac{1}{2}mv^2 = \alpha T, \text{ where, } \alpha = \frac{3}{2} \cdot \frac{R}{N}.$$

Now, the most probable value of the ionic charge e is 1.57×10^{-20} electromagnetic unit, and therefore the passage of 1 electromagnetic unit of charge through acidulated water liberates $\frac{1}{1.57 \times 10^{-20}}$ ions at each electrode. But this also liberates 0.0001044 gramme of hydrogen, and therefore the number of atoms per gramme of hydrogen is $\frac{10^{24}}{1.57 \times 1.044}$, and since one gramme-molecule of hydrogen is 2 grammes, the number of atoms to the molecule being 2, the number of molecules to the gramme molecule, or N

$$\begin{aligned} &= \frac{10^{24}}{1.57 \times 1.044} = 6.10 \times 10^{23}, \\ \therefore \alpha &= \frac{3}{2} \times \frac{8.315 \times 10^7}{6.10 \times 10^{23}} = 2.04 \times 10^{-16}. \end{aligned}$$

In the case of hydrogen at 0°C . and 76 cms. pressure we may easily find the mean square velocity of the molecules, for

$$\begin{aligned} p &= \frac{1}{3}Nmv^2 = \frac{1}{3}(\text{density})v^2, \\ \therefore 76 \times 13.596 \times 981 &= \frac{1}{3}(0.00008987)v^2, \\ \text{from which, } v^2 &= 3.38 \times 10^{10}, \\ \text{and, } v &= 1.84 \times 10^5. \end{aligned}$$

If now the electrons within a conductor are in temperature equilibrium with their surroundings, we can find their velocity according to the kinetic theory; for $\frac{1}{2}mv^2$ is the same for them as for any

other gas molecules at the same temperature. Taking their mass as $\frac{1}{18.36}$ of that of a hydrogen atom,

$$\frac{1}{2}m_h v_h^2 \text{ (for hydrogen)} = \frac{1}{2}m_e v_e^2 \text{ (for electron),}$$

$$\therefore v_e^2 = \frac{m_h}{m_e} \cdot 3.38 \times 10^{10}$$

$$= 1835 \times 3.38 \times 10^{10}$$

$$= 6.20 \times 10^{13}$$

$$v = 7.87 \times 10^6 \text{ cms. per sec.}$$

Electrical Conduction.—In addition to this motion of the electrons which takes place in all directions, we shall have, in the presence of an electric field, a drift in the direction of the field, or rather in the opposite direction, since the charges are negative. Assuming that after each collision with a molecule of the conductor, the electron starts afresh with the velocity corresponding to temperature equilibrium with the substance, it will in the time that elapses before the next collision, be subject to the influence of the electric field, and will on that account have an acceleration $f = \frac{Ee}{m}$ parallel to the field, where E is the electric intensity.

The different electrons will have various distances of travel between two collisions, but the average distance is called the length of mean free path, λ , and the time taken in describing this mean free path is $\frac{\lambda}{v}$. Hence the distance travelled in the direction of the field on

account of the acceleration $\frac{Ee}{m}$, is $\frac{1}{2} \cdot \frac{Ee}{m} \cdot \frac{\lambda^2}{v^2}$

and the average velocity in this direction is—

$$\frac{\text{distance}}{\text{time}} = \frac{1}{2} \cdot \frac{Ee}{m} \cdot \frac{\lambda^2}{v^2} \cdot \frac{v}{\lambda}$$

$$= \frac{1}{2} \cdot \frac{Ee\lambda}{mv}$$

$$\text{But } \frac{1}{2}mv^2 = \alpha T, \text{ or, } m = \frac{2\alpha T}{v^2},$$

$$\therefore \text{average velocity in direction of field} = \frac{Ee\lambda v}{4\alpha T}.$$

The corresponding current is $Ne \times \text{velocity}$, where N is the number of electrons per unit volume,

$$\therefore \text{current} = \frac{NEe^2\lambda v}{4\alpha T} = i,$$

$$\text{and conductivity, } \sigma = \frac{i}{E} = \frac{Ne^2\lambda v}{4\alpha T} = \frac{Ne^2\lambda}{4\alpha T} \sqrt{\frac{2\alpha T}{m}} = \frac{Ne^2\lambda}{2\sqrt{2\alpha T m}}$$

Hence Ohm's law is obeyed, for the conductivity is independent of the current, but the conductivity should be inversely proportional to the square root of the absolute temperature. But for most pure metals the conductivity is found to vary inversely as the absolute temperature,

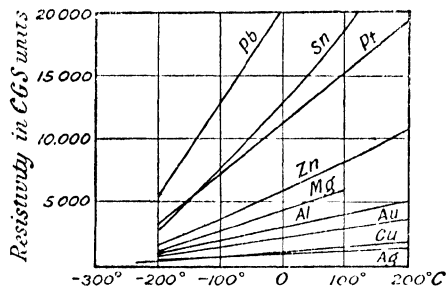

FIG. 450.

or, what is the same thing, the resistivity is proportional to the absolute temperature. The curves for some of the pure metals, taken from Dewar and Fleming's¹ results, show that down to quite low temperatures the resistivity behaves as though it would vanish at the absolute zero of temperature (Fig. 450).

In the above expression for the electrical conductivity, the only quantities

that are likely to vary from one substance to another are N and λ .

Now, it is probable that λ would vary greatly, so that it is concluded that the great differences in conductivity between different materials arises from the difference in the quantities of free electrons in them.

Thermal Conductivity.—The close connection between electrical and thermal conductivity has long been known; in fact, the law of Wiedemann and Franz² states that the ratio of the conductivity for heat to the electrical conductivity at any temperature is constant for all metals, and is proportional to the absolute temperature.

Drude's theory gives an explanation of this, by treating the electrons in the conductor in a manner similar to that in which molecules are dealt with in the kinetic theory of gases. Consider a plane AB in the conductor, and two others E and F parallel to it and at distances from it equal to the mean free path of the electrons (Fig. 451). Returning to our method of dividing the total number of electrons N per unit volume into six groups, we see that $\frac{N}{6}$ are crossing unit area of AB from left to right,

while an equal number cross from right to left. The remaining groups are moving parallel to AB and will not further concern us. If the temperature is the

same everywhere, those passing from left to right carry the same amount of energy as those from right to left, and the resultant energy transferred in any direction is zero.

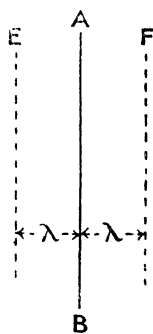

FIG. 451.

¹ Dewar and J. A. Fleming, *Phil. Mag.*, 36, p. 271. 1893.

² G. Wiedemann and R. Franz, *Pogg. Ann.*, 89, p. 497. 1853.

If now the temperature at the plane E is T_1 and is higher than the temperature T_2 at F, those passing from left to right have greater energy than those passing in the opposite direction, and there is a transference of heat through AB from left to right. Only those electrons that lie between E and AB will cross without collision, since any on the left of E are at a distance greater than the mean free path and will experience collision without reaching AB, and their direction then becomes changed.

Again, the number of electrons per unit volume travelling from left to right is $\frac{N}{6}$, and since their velocity when passing AB is v , the number crossing unit area of AB in unit time is $\frac{N}{6}v$, and since each has kinetic energy $\frac{1}{2}mv_1^2$, where v_1 is the velocity corresponding to temperature T_1 at E,

Energy carried in one second from left to right through unit area is

$$\frac{N}{6}v \cdot \frac{1}{2}mv_1^2 = \frac{N}{6}vaT_1 \quad (\text{since } \frac{1}{2}mv^2 = aT).$$

Similarly,—energy passing from right to left = $\frac{N}{6}vaT_2$.

Therefore,—balance of energy carried in one second through unit area of AB = $\frac{N}{6}va(T_1 - T_2)$.

It should be noticed that the number crossing in each direction must be the same, since the pressure at all points remains constant. If this were not the case there would be a drift of electrons in one direction or the other, and the process of transference of heat would not be one of pure conduction.

Now, if the thermal conductivity be k , then, since the temperature gradient at AB is $\frac{T_1 - T_2}{2\lambda}$, the transference of heat per second through unit area is $k \times \frac{T_1 - T_2}{2\lambda}$.

$$\text{Hence, } \frac{N}{6}v \cdot a(T_1 - T_2) = k \frac{T_1 - T_2}{2\lambda},$$

$$\therefore k = \frac{Nva\lambda}{3}.$$

Remembering that the electrical conductivity is given on p. 551 by

$$\sigma = \frac{Ne^2\lambda v}{4aT},$$

$$k = \left(\frac{a}{e}\right)^2 \cdot \frac{4}{3}T\sigma,$$

we see that,

which is in agreement with the law of Wiedemann and Franz. The following table gives a few of the ratios $\frac{k}{\sigma}$ determined by Jager and Diesselhorst.¹

	$\frac{k}{\sigma}$	Temperature coefficient
Copper	6.71×10^{10}	3.95×10^{-3}
Silver	6.86×10^{10}	3.77×10^{-3}
Gold	7.09×10^{10}	3.75×10^{-3}
Zinc	6.72×10^{10}	3.85×10^{-3}
Lead	7.15×10^{10}	4.07×10^{-3}
Tin	7.35×10^{10}	3.4×10^{-3}
Platinum	7.53×10^{10}	4.64×10^{-3}
Bismuth	9.61×10^{10}	1.51×10^{-3}
Constantan	11.06×10^{10}	2.39×10^{-3}
Manganin	9.14×10^{10}	2.74×10^{-3}

It will be seen that for the pure metals, with the exception of bismuth, the ratio $\frac{k}{\sigma}$ is very fairly constant, and the temperature coefficient is nearly 3.66×10^{-3} , the coefficient of expansion of a gas. Hence the electronic theory gives some approximation to a true explanation of these processes.

Again, since $a = 2.04 \times 10^{-16}$, and $e = 1.57 \times 10^{-20}$, we have—

$$\begin{aligned} \frac{k}{\sigma} &= \left(\frac{2.04 \times 10^{-16}}{1.57 \times 10^{-20}} \right)^2 \times \frac{1}{3} \times 273 \\ &= 6.14 \times 10^{10}. \end{aligned}$$

This value is sufficiently near the observed value to strengthen the theory considerably. It should be noticed that we have used the kinetic theory in its simplest form in assuming the electrons to be divided into six groups of constant velocity. The more exact partition of velocities, taking into account the motion in all directions and with all magnitudes, leads to results differing from the above in a numeral factor only.

Peltier Effect.—A simple explanation of the thermoelectric effects may be given on the electronic theory we have been considering. For if the pressures due to the electrons in two metals are different, then on placing them in contact, electrons will pass from one to the other until the difference of potential produced, prevents the further passage of the electrons. If then a current passes from one metal to the other across the junction, E units of work are performed when one unit of

¹ W. Jager and H. Diesselhorst, *Wiss. Abh. der Phys. Tech. Reichsanstalt*, 3, 1900.

electricity passes, where E is the Peltier coefficient at the junction. The pressure due to the electrons in the first metal is—

$$\frac{1}{3}N_1mv_1^2 = \frac{2}{3}N_1a'T,$$

and in the second metal,

$$\frac{1}{3}N_2mv_2^2 = \frac{2}{3}N_2a'T,$$

since the two metals are assumed to be at the same temperature.

Now, one unit of electricity corresponds to $\frac{1}{e}$ electrons, which will occupy a space $\frac{1}{N_1e}$ cubic centimetres in the first metal and $\frac{1}{N_2e}$ in the second.

Work done in transferring $\frac{1}{e}$ electrons from first to second metal

$$= \int_{v_1}^{v_2} p dv = \frac{2}{3}a'T \int_{v_1}^{v_2} N dv \text{ (from above),}$$

and since, $v = \frac{1}{Ne}$,

$$\begin{aligned} \text{work done} &= \frac{2}{3} \cdot \frac{a}{e} T \int_{v_1}^{v_2} \frac{dv}{v} = \frac{2}{3} \cdot \frac{a}{e} T \log_e \frac{v_2}{v_1} \\ &= \frac{2}{3} \cdot \frac{a}{e} T \log_e \frac{N_1}{N_2}. \end{aligned}$$

$$\text{Hence, } E = \frac{2}{3} \cdot \frac{a}{e} T \log_e \frac{N_1}{N_2},$$

an equation given by Sir J. J. Thomson.¹

We can form an estimate of the relative number of electrons per unit volume in the two metals for the production of the known Peltier effect. Consider the case of antimony and bismuth, across the contact of which metals at 0° C. there is an electromotive force of about $\frac{1}{30}$ volt.

$$\begin{aligned} \frac{1}{30} \times 10^8 &= \frac{2}{3} \cdot \frac{aT}{e} \log_e \frac{N_2}{N_1} \\ &= \frac{2}{3} \cdot \frac{2.04 \times 10^{-16} \times 273}{1.57 \times 10^{-20}} \log_e \frac{N_2}{N_1}, \end{aligned}$$

$$\log_e \frac{N_2}{N_1} = 1.41,$$

$$\frac{N_2}{N_1} = 4.1.$$

Thus, to account for the magnitude and direction of the Peltier

¹ J. J. Thomson, "Corpuscular Theory of Matter."

effect in this extreme case it is only necessary to suppose that the free electrons are four times as numerous in the bismuth as in the antimony.

In a similar manner the Thomson effect (p. 208) would be accounted for by the higher pressure at those parts of the metal at which the temperature is above that of the remainder, the pressure being $\frac{2}{3}NaT$. Thus the energy of the electrons in the bar is increased when the current flows from hot to cold parts so that the electrons, being negative charges, are carried from points of lower to points of higher pressure, and the passage of the current warms the bar. Thus the Thomson coefficient is positive, as in the case of bismuth, copper, etc. But it must be remembered that the passage of the current causes negative electrons to be carried out from the hotter end of the bar, that is, from points where their kinetic energy is greatest, and in at the colder parts, that is, where their kinetic energy is least. This would cause the bar to be cooled, and would correspond to a negative Thomson effect, as in antimony, iron, etc. Since the distribution of the electrons with temperature is not known, the theory cannot yet be satisfactorily applied to account for the Thomson effect.

Hall Effect.—It was found by Hall¹ that when a magnetic field is applied at right angles to a conductor in which an electric current is flowing, a transverse electromotive force arises at right angles to both current and field, so that there is a difference of potential between the two edges of the conductor. In Fig. 452, if the current is parallel to the X axis and the field parallel to the Y axis, the faces A and B of the conductor are at different potentials. A sheet of the material is employed, the current passing through it from one end to the other, with the magnetic field at right angles to the plane of the sheet. Hall attached terminals to the sides of the sheet, and observed the current in a galvanometer connected to them; but a better method of measuring the effect is to compensate the

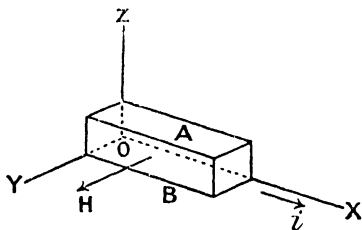

FIG. 452.

electromotive force so that no current flows in the galvanometer circuit—in other words, to employ the potentiometer method.

The magnitude of this transverse electromotive force is strictly proportional to the current density and to the transverse width of the conductor, and though generally proportional to the strength of magnetic field, this is not always rigidly so.

Thus,— difference of potential = $RHidz$,

where H is the strength of field, i the current density, and dz the width

¹ E. H. Hall, *Phil. Mag.*, 12, p. 157. 1880.

of the conductor at right angles to field and current, R being the coefficient of the Hall effect. The following values are given by Baedeker :¹—

Gold	-0.00070	Bismuth	-11 (crystallographic axis perpendicular to H)
Silver	-0.00088	Bismuth	-0.4 (crystallographic axis parallel to H)
Copper	-0.00054	Antimony	+0.1 to 0.2
Platinum	-0.0002	Tellurium	+500 (about)
Carbon	-0.17		
Iridium	+0.00040		
Zinc	+0.0006 (about)		

For the ferromagnetic metals, the Hall effect varies in a similar manner to the permeability, disappearing at the critical temperature. For low temperatures, in the case of iron and nickel R is about +0.01 and for cobalt about 0.004.

With the relative directions of current and field in Fig. 452, B is at a higher potential than A when the Hall effect is positive, and *vice versa*.

The explanation of the Hall effect by the electronic theory is not entirely satisfactory. With a current flowing in the direction indicated in Fig. 452 the electrons are travelling in the direction XO, and the effect of the magnetic field would be to deflect them downwards. Hence B would on this account be at a lower potential than A, the direction of the transverse electromotive force being that observed in the metals having a negative coefficient of the Hall effect. The occurrence of a positive coefficient in some cases is not easy to account for if the current is carried entirely by electrons having negative charges. If the current were partly due to the motion of positively charged carriers the matter would be easy, for whatever the sign of the carriers the displacement would be downwards in the figure. But in the case of positive carriers, this would raise the potential of B above that of A, and the sign of the Hall effect would be that observed in antimony, etc. We can only say that the electronic theory is at present too incomplete to account properly for all the phenomena of conduction.

Nernst and Ettinghausen Effect.—On maintaining a temperature gradient in a metal sheet, it was found by Nernst and Ettinghausen² that in presence of a transverse magnetic field, applied as in Hall's experiment, a potential difference exists between the edges of the sheet. This might be expected upon the electronic theory, for both heat and electrical conduction are supposed to be due to transmission of the electrons. Those moving from the hotter part of the metal have greater velocity, and are therefore more deflected by the magnetic field, than the more slowly moving electrons from the cooler parts.

¹ K. Baedeker, "Die Elektrischen Erscheinungen in Metallischen leitern."

² H. W. Nernst and A. von Ettinghausen, *Wied. Ann.*, 29, p. 343. 1896.

$$\text{Difference of potential} = Q \cdot H \cdot \frac{dT}{dx} dz,$$

where Q is the coefficient of the Nernst and Ettinghausen effect.

Ettinghausen Effect¹—A temperature difference is established between the edges of the plate along which a current is flowing, when there is a magnetic field at right angles to the plane of the plate. This effect is much smaller than the last described, and might have been expected from the transverse deflection of the electrons which gives rise to the Hall effect.

$$\delta T = -\frac{P}{dy} H dz.$$

Leduc Effect.²—In this case there is a transverse difference of temperature between the edges of the plate when a temperature gradient exists in the magnetic field.

$$\delta T = SH \cdot \frac{dT}{dx} \cdot dz.$$

The above four effects have been investigated by Zahn,³ who gives the following values for the four respective coefficients:—

	R.	S.	Q.	P	
Platinum . . .	-1.27×10^{-4}	-2.1×10^{-8}	Very small	} Not measurable	
Copper	-4.28×10^{-4}	-23.2×10^{-8}	$+2.7 \times 10^{-4}$		
Silver	-8.97×10^{-4}	-40.4×10^{-8}	$+4.3 \times 10^{-4}$		
Zinc	$+10.4 \times 10^{-4}$	$+12.9 \times 10^{-8}$	$+2.4 \times 10^{-4}$		
Iron	$+10.8 \times 10^{-4}$	$+39 \times 10^{-8}$	$+10.5 \times 10^{-4}$		-5.7×10^{-8}
Steel	$+133.6 \times 10^{-4}$	$+68.7 \times 10^{-8}$	$+16.6 \times 10^{-4}$		-6.7×10^{-8}
Nickel I. . . .	-46.9×10^{-4}	-20×10^{-8}	-13×10^{-4}		$+2.8 \times 10^{-8}$
„ II. . . .	-125×10^{-4}	-55×10^{-8}	-35.5×10^{-4}	$+17.6 \times 10^{-8}$	
Antimony . .	$+2190 \times 10^{-4}$	$+202 \times 10^{-8}$	-176×10^{-4}	$+134 \times 10^{-8}$	

Longitudinal Effects.—It would follow from the consideration of the above-described transverse effects that the electrons will, due to the transverse motion imposed upon them, now experience similar forces still at right angles to the magnetic field and to their present motion, which therefore makes the effect parallel to the original current or temperature gradient. Thus in the Ettinghausen and the Leduc effects, the upper edge of the plate is at a different temperature to the

¹ A. von Ettinghausen, *Wied. Ann.*, **31**, p. 737. 1887.

² A. Leduc, *Journ. d. Phys.*, **6**, p. 378. 1887.

³ H. Zahn, *Ann. der Phys.*, (3) **14**, p. 886 (1904); and **16**, p. 148 (1905).

lower, the electrons travelling from the hotter part have greater velocity and are deflected more by the magnetic field than those from the colder part, thus giving rise to a longitudinal temperature effect. Also in the case of the Hall effect, the lateral displacement of the electrons causes them to experience a force due to the magnetic field, which force is in this case parallel to the original current. The motion of the electrons will thus resemble the motion of the ions in a magnetic and electric field at right angles to each other (p. 475); their path is curved, the component of their velocity in the direction of the electric field being less the stronger the transverse magnetic field. The result is therefore to reduce the current, or, in other words to increase the resistance of the conductor. This increase in resistance has been observed in several cases, particularly in that of bismuth, in which metal the Hall effect is very great.

The increase in resistance is independent of the direction of the magnetic field, and may therefore be taken as proportional to the square of the field strength. In the relation—

$$\frac{\delta r}{r} = A H^2,$$

the constant A has been determined for a number of materials and is of the order 10^{-12} , varying from 0.06×10^{-12} in the case of platinum to 2.8×10^{-12} for cadmium.

In the case of bismuth the effect is complicated, but is sufficiently great to afford a means of measuring magnetic field by determining the resistance of a standardized conductor of bismuth when situated in the field.

The properties of bismuth are in many ways peculiar, as, for example, the variation in resistance to continuous and to alternating current, discovered by Lenard. The resistance to the alternating current depends on the frequency, being less the higher the frequency. Pallme-König,¹ on examining a bismuth wire in currents of very short duration, found that the resistance for a rising current is always less than that for a falling current.

In the present chapter a very brief outline of the electronic theory has been given, the object being rather to point out some of the cases in which it has been useful in explaining and in drawing together apparently widely separated phenomena. The weaknesses of the theory have been barely touched upon, our object being neither to establish nor to disprove it, but to introduce the student to the method of regarding physical phenomena which the work of the last ten or fifteen years has produced.

¹ Pallme-König, *Ann. d. Phys.*, **25**, p. 921. 1908.

TABLE OF TRANSVERSE AND LONGITUDINAL EFFECTS DUE TO A TRANSVERSE MAGNETIC FIELD.

	Transverse.	Longitudinal.
Electro-electric .	Hall. Transverse electromotive force when current flows at right angles to magnetic field.	Change in electrical conductivity.
Electro-thermal .	Ettinghausen. Transverse difference of temperature when current flows at right angles to magnetic field	Longitudinal difference of temperature.
Thermo-electrical	Nernst and Ettinghausen. Transverse electromotive force when flow of heat takes place at right angles to magnetic field.	Longitudinal electro-motive force.
Thermo-thermal .	Leduc. Transverse difference of temperature when flow of heat takes place at right angles to magnetic field	Change in thermal conductivity.

APPENDIX

Characteristic X-rays.—It was found by Barkla and Sadler¹ that most substances emit one or more kinds of homogeneous secondary X-rays, the character of which depends only upon the nature of the substance and not upon the quality of the primary rays. But in order to produce any characteristic X-ray, the primary X-rays must be at least as hard as the characteristic X-rays produced. Moreover, the characteristic X-rays can be used as primary rays to produce other characteristic X-rays of less penetrability.

Some elements can be caused to emit two characteristic radiations, of which one is about 300 times as penetrating as the other. Barkla called the harder of the two, for the various elements, the series K radiations, and the softer, the series L. For both the K and the L series the hardness increases with the atomic weight of the element. For some elements such as silver, antimony, and barium, both the series K and the series L radiations have been observed. For the elements of low atomic weight only the series K radiation has been observed, and for those of high atomic weight, only the series L.

Whiddington² found a relation between the atomic weights of the elements and the penetrating power of their characteristic X-rays. If an element whose atomic weight is A_K has a series K radiation of the same penetrating power as the series L radiation of an element of atomic weight A_L , then—

$$A_K = \frac{1}{2}(A_L - c),$$

where c is a constant whose value has been found to be nearly 48.

$$\therefore A_K = \frac{1}{2}(A_L - 48).$$

Thus the series K radiation of bromine (at. wt. = 80) has the same penetrating power as the series L radiation of bismuth (at. wt. = 208).

Whiddington³ has also measured the minimum velocity of the cathode rays required for the production of rays of the hardness of any given characteristic ray, and found it to be proportional to the atomic weight of the element. For the series K radiation—

$$V_K = A \cdot 10^8 \text{ cm. per sec.},$$

and for the series L—

$$V_L = \frac{1}{2}(A - 48) \cdot 10^8 \text{ cm. per sec.},$$

where A is the atomic weight of the element.

¹ C. G. Barkla and C. A. Sadler, *Phil. Mag.*, **16**, p. 550, Oct., 1908.

² R. Whiddington, *Nature*, p. 143, Nov. 30, 1911.

³ R. Whiddington, *Proc. Roy. Soc. A.*, **85**, p. 323. 1911.

Interference and Reflection of X-rays.—That X-rays consist of an electro-magnetic disturbance travelling outwards has been believed for some time, but whether they consist of single impulses (p. 528) or of a train of impulses constituting light of very short wave-length was difficult to determine. They had resisted all attempts to reflect them or to produce interference, until the suggestion of Prof. Laue¹ that the atomic structure of crystals might form a sufficiently fine diffraction "grating" for this purpose. Friedrich and Knipping² placed crystals of copper sulphate, rock salt, diamond, or zinc blend in the path of a fine beam of X-rays, the transmitted beam falling upon a photographic plate. In addition to the central spot, a diffraction pattern was observed in each case, the positions of the spots being in accordance with Laue's theory. Fig. 453 shows one of their photographs for zinc blend.

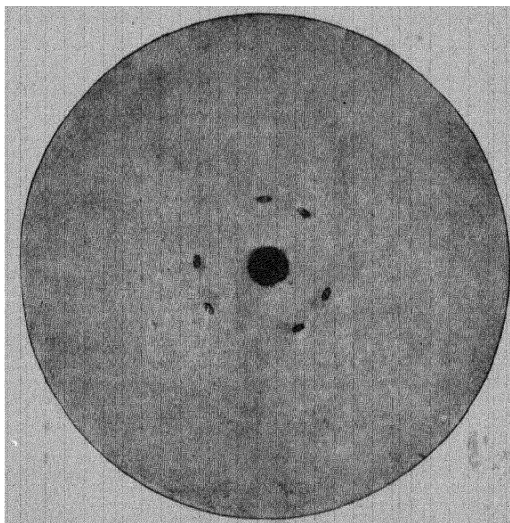

From "X-rays," by G. W. C. Kaye.

FIG. 453.

Prof. W. H. Bragg has accounted for the position of the diffraction spots, by reflection of the X-rays from successive planes in the crystal which are rich in atoms. He has determined the wave-length of the X-rays, and also, in many cases, the dimensions of the space-lattice and distribution of the atoms in the crystal. It is found that each characteristic secondary X-ray has a particular wave-length.

X-rays may be reflected at nearly grazing incidence from various crystals possessing marked cleavage planes, such as mica, the direction of the reflected beam depending on the wave-length of the incident X-rays. The wave-length of X-rays appears to be of the order 1×10^{-8} cm. For a fuller

¹ M. Laue, *Phys. Zeitschr.*, 14, p. 421. 1913.

² W. Friedrich, P. Knipping, and M. Laue, *Le Radium*, 10, p. 47. 1913.

account of Bragg's theory and his experimental work the student is advised to consult "X-rays and Crystal Structure," by W. H. Bragg and W. L. Bragg.

A comprehensive study of these high-frequency spectra produced by reflection of the characteristic X-rays from a number of metals at nearly grazing incidence has been made by Moseley.¹ He found that the spectrum for each metal, from calcium to zinc, consisted of two sharp lines which have the same relative intensity and relative wave-length for the different metals. The lines of greater wave-length are the more intense, and correspond to the series K radiation. The wave-length is smaller the higher the atomic weight of the metal. For calcium K radiation $\lambda = 3.36 \times 10^{-8}$ cm., and for palladium $\lambda = 0.575 \times 10^{-8}$ cm. For a comprehensive account of X-rays and their properties the student should see "X-rays," by G. W. C. Kaye.

Thermions.—If the free electrons in a metal have velocities corresponding to their temperature, it would follow, as in the case of gases, that the electrons have not the same individual velocities. In fact, the distribution of velocities would be expected to be the same as that for the molecules of a gas, which was calculated by Maxwell. On the other hand, the escape of electrons through the surface of the metal requires work to overcome the attraction of the remaining positively charged metal. Only those electrons which have sufficiently great velocity will escape. This escape means a negative current flowing outwards through the surface of the metal, and corresponds closely to the escape of molecules from a liquid in the process of evaporation. Consequently the current increases with rise of temperature. The question has been investigated by O. W. Richardson,² who has shown that the escape of electrons from a metal into a gas at very low pressure varies with temperature in a manner which is in accord with Maxwell's expression for velocity distribution. The subject has been named *thermionics* by Richardson, and the ions emitted by hot substances he calls *thermions* (also see p. 493).

Positive Rays.—The streams of positively charged bodies first noticed in the case of the canal rays (p. 488) and afterwards in the α -rays from radioactive substances (p. 501) are usually grouped under the name of *positive rays*, which name indicates the nature of the electric charge carried by them. The positive rays in the discharge tube are of a complex nature. By using large vacuum vessels so that the discharge could be obtained at very high p.d. without injuring the tube, Sir J. J. Thomson³ found the existence of positive rays whose nature depended upon the gas present in the tube.

The method employed was that of the application of an electric and a magnetic field coincident in position and direction. The charged particle then undergoes a displacement $y = \frac{e}{m} \cdot \frac{1}{v^2} \cdot \frac{Fd^2}{2}$ in passing through a path d cm. in the electric field E (p. 506) and a displacement x at right angles to this and due to the magnetic field—

$$x = \frac{d^2}{2} \cdot \frac{e}{m} \cdot \frac{H}{v}.$$

¹ H. G. Moseley, *Phil. Mag.*, **26**, p. 1024, Dec., 1913.

² O. W. Richardson and F. C. Brown, *Phil. Mag.*, **16**, p. 353, Sept., 1908, and O. W. Richardson, *Phil. Mag.*, **17**, p. 813, June, 1909.

³ J. J. Thomson, *Phil. Mag.*, **21**, p. 225, 1911.

Combining these two—

$$\frac{x}{y} = v \cdot \frac{H}{E} \quad \text{and,} \quad \frac{x^2}{y} = \frac{e}{m} \cdot \frac{d^2}{2} \cdot \frac{H^2}{E}$$

The positive rays, which arise in the dark space in the vacuum tube, travel through a fine hole in the kathode several cm. long. They then pass through the electric and magnetic fields and fall upon the plate, giving an undeflected patch at O (Fig. 454) and curves such as AB, CD, EF, etc. In the earlier experiments the screen was rendered fluorescent with willemite, but this was later replaced by a photographic plate. Every point upon the screen corresponds to some particular value of $\frac{e}{m}$ and velocity for the travelling particles. For all those having the same velocity, $\frac{x}{y}$ is constant, so that these points lie on straight lines such as OG passing through the origin.

On the other hand, for all particles having the same value of $\frac{e}{m}$, $\frac{x^2}{y} = \text{constant}$, and these curves are parabolas having vertexes at O. It is therefore highly probable that each parabola corresponds to a different kind of particle, and by measuring the constants of the parabolas the values of $\frac{e}{m}$ have been found.

The photographic plate does not give a good measurement of the intensity of each kind of ray, owing to the fact that the more rapidly moving particles

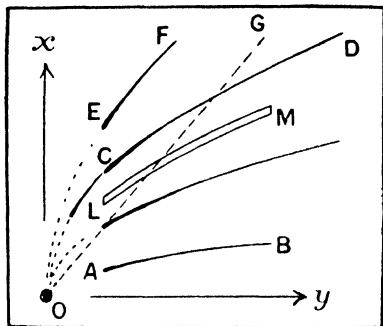

FIG. 454.

penetrate further into the photographic films than the slower ones. Thus for quantitative measurements a parabolic slit LM (Fig. 454) in a metal screen is provided. By varying the magnetic field, one parabola after another can be brought upon the slit. These rays then pass through, and entering a Faraday cylinder connected to a Wilson tilted electroscope, the rate of motion of the leaf is a measure of the charge carried by the rays. The comparative intensity of the rays producing the various parabolas for any given gas in the tubes can be found.

By this means Sir J. J. Thomson was able to observe the presence of a great variety of atoms and molecules, for example, the hydrogen atom with one ultimate unit of charge (p. 488), and the hydrogen molecule with one unit. Taking $\frac{m}{e}$ as unity for the hydrogen atom, H^+ has the value 1. Then $H_2^+ = 2$. The following have also been observed: $O^+ = 16$, $O_2^+ = 32$, $O^{++} = 8$, $O_3^+ = 48$. The molecule never appears to take more than one

fundamental unit of charge, but the atom can take a varying number, which increases with the atomic weight. Thus in the case of mercury, from one to eight units may be taken, giving values of $\frac{m}{e}$ of 200, corresponding to 200/1, 102 to 200/2, 66.8 to 200/3, 50.4 to 200/4, 39.8 to 200/5, 33.7 to 200/6, 28.6 to 200/7. Also crypton (82) takes four or five in atomic charges, argon (40) three, neon (20) two, nitrogen (14) and oxygen (16) two, helium (4) two. Hitherto unknown substances have also been found, one for which $m/e = 3$ which has been named X_3 and which may be H_3 , and another which would correspond to an element of atomic weight 22, which may prove to be a new element.

EXAMPLES

EXAMPLES I.

1. Two short magnets, with their axes horizontal, and perpendicular to the magnetic meridian, are placed with their centres 30 centimetres east and 40 centimetres west respectively of a compass-needle. Compare the moments of the magnets if the needle remains undeflected, and show how to derive the formula employed in the calculation. (B. of E. 2, 1911.)

2. How would you verify experimentally the law connecting the force between two magnetic poles with the distance between the poles? Make some rough estimate of the percentage accuracy of which the method is capable. (Lond. Univ. B.Sc. Ext., 1906.)

3. Define Magnetic Potential, and find the magnetic potential at any point due to a very short magnet. Show that the magnetic moment of such a magnet may be treated as a vector. (Lond. Univ. B.Sc. Ext., 1909.)

4. Find expressions for the turning effect and for the attraction of one small magnet on another. (Lond. Univ. B.Sc. Hon. Internal., 1910.)

5. Show how mechanical principles are not violated by the fact that the couple exerted by one magnet on another is, in general, not the same as that of the second on the first. (Lond. Univ. B.Sc. Hon. Internal., 1911.)

6. Two magnets of the same length l are placed with their axes parallel and their centres at a considerable distance R from a point P , one with its axis passing through P , the other with P on the line through its centre perpendicular to its axis. Find how the magnets must be oriented, and what must be the relation between their moments in order that the magnetic field at P due to them may be independent of powers of $\frac{l}{R}$ lower than the fourth. (Lond. Univ. B.Sc. Ext., 1911.)

7. Find the magnitude and direction of the magnetic field due to a small magnet of moment 30 , at a point situated on a line passing through the middle of the magnet and at an angle of 60 degrees with its axis, the point being at a distance of 5 cms. from the magnet.

EXAMPLES II.

1. Describe, giving all necessary correcting terms, how you would determine, in absolute measure, the horizontal component of the earth's magnetic field. (Lond. Univ. B.Sc. Internal., 1906.)

2. Describe some method of comparing H and V , the horizontal and vertical components of the earth's magnetic field.

Show that the ratio $H \div V$ would be equal to $\frac{\cot \theta}{2}$, where θ is the

latitude, if the magnetic field were due to a magnet at the centre of the earth with its axis pointing north and south. (Lond. Univ. B.Sc. Ext., 1907.)

3. Describe the method adopted to determine the variation of the horizontal component of the earth's magnetic field, and find an expression for the deflection produced in terms of the variation of the component. (Lond. Univ. B.Sc. Ext., 1909.)

4. Give an outline of the determination of H —the horizontal magnetic field of the earth—by employment of a bar magnet and a magnetic needle.

How is the effect of the length of the bar magnet eliminated by observing deflections of the needle by the bar magnet at two different distances of the latter? (Lond. Univ. B.Sc. Internal., 1910.)

5. Write an essay on terrestrial magnetism, keeping in view more especially its probable causes. (B. of E. Hon. I., 1907.)

6. Give a short account of how it is possible to neutralise the disturbing action of the magnetised iron and steel of a ship on a compass needle. (B. of E. 3, 1908.)

7. Explain how the daily variation of the intensity of the earth's magnetic field may be continuously recorded. (B. of E. 3, 1910.)

8. A magnet weighing 15 grammes has a small straight stem (length = 4 mm.) fixed centrally at right angles to the magnetic axis. The whole is suspended by a silk fibre attached to the upper end of the stem, at a place where the dip is 60° . Calculate the angle which the magnet makes with the horizontal, its magnetic moment being 100 units. (Lond. Univ. B.Sc. Internal., 1905.)

EXAMPLES III.

1. What is the reason for using as small a suspended magnet as possible in the tangent galvanometer?

Describe an arrangement of coils by which the necessity for a very small magnet is removed, stating the reasons.

2. Two similar coils of wire, having a radius of 7 cms. and 60 turns, have a common axis and are 18 cms. apart. Find the strength of magnetic field (a) at the centre of either coil, and (b) at a point on their common axis midway between them.

3. Describe a method of calculating the resistance between two points in a network of conductors. (B. of E. 3, 1905.)

4. Find the resistance of a cubic centimetre of copper (a) when drawn out into a wire of diameter 0.32 mm. and (b) when hammered into a flat sheet of thickness 1.2 mm. the current flowing perpendicularly through the sheet from one face to the other. (Specific resistance = 1.59×10^{-6} .)

5. Find the most sensitive arrangement for the Wheatstone's net when the galvanometer has a much greater resistance than the battery, and the resistances of the arms are very unequal.

6. State the laws governing the distribution of current in a network of wires.

A battery of 6 volts E.M.F. and 0.5 ohm internal resistance is joined in parallel with another of 10 volts E.M.F. and 1 ohm internal resistance, and the combination used to send current through an external resistance of 12 ohms. Calculate the current through each battery. (Lond. Univ. B.Sc. Ext., 1910.)

7. State Kirchhoff's Laws of distribution of electric currents in networks of conductors, and justify by means of them or otherwise the method of determining the resistance of a voltaic cell by placing it in one arm of a resistance bridge. (Lond. Univ. B.Sc. Ext., 1911.)

8. Define the ampere, and find the direction and intensity of the force on a

circular coil of n turns wound close together through which a current of A amperes is flowing due to a magnet whose poles lie on the axis of the coil. (Lond. Univ. B.Sc. Ext., 1911.)

9. The reactions within a cell generate electrical energy at the rate of 1 watt per ampere; a current of 10 amperes is being generated with the result that energy is dissipated within the cell in the form of heat at the rate of 1 watt. What is the difference of potential between the terminals of the cell, also what is the internal resistance of the cell? (Lond. Univ. B.Sc. Internal., 1909.)

10. Show how to calculate the current through the galvanometer in the Wheatstone bridge arrangement of conductors when nearly balanced. (Lond. Univ. B.Sc. Hon. Internal., 1910.)

EXAMPLES IV.

1. Describe how you would determine a very small resistance accurately. (B. of E. 2, 1911.)

2. Describe the moving coil galvanometer, giving its advantages and disadvantages compared with the needle galvanometer. (B. of E. 2, 1911.)

3. Describe carefully how you would use a potentiometer for measuring currents. How would you adapt it for use with large and small currents respectively? (Lond. Univ. B.Sc. Internal., 1905.)

4. Describe the construction of the moving coil galvanometer, and explain how, with the addition of a shunt, it can be used as an ammeter for large currents. (Lond. Univ. B.Sc. Ext., 1908.)

5. What difficulties are met with in measuring a very small resistance by the Wheatstone's bridge method? Describe a method of comparing low resistances. (Lond. Univ. B.Sc. Internal., 1909.)

6. Describe some form of ammeter in which the reading is proportional to the square of the current.

EXAMPLES V.

1. Why does a sharp point attached to an electrical machine prevent a high potential being obtained, while a knob has no such effect?

Describe some practical application of the above action of points. (B. of E. 2, 1911.)

2. Give an account of the method employed by Cavendish and Maxwell to prove that the law of inverse square of the distance holds in electrostatics. How can the degree of accuracy attained in such experiments be estimated? (Lond. Univ. B.Sc. Internal., 1907.)

3. Define the term *potential*, as applied to conductors in electrostatics.

Show that the potential must be the same at all points in the air space completely surrounded by a conductor. (Lond. Univ. B.Sc. Ext., 1908.)

4. What is an electrical image?

A point charge is placed 3 cm. in front of an infinite plane conductor. Show that the total induced charge on the portion of the plane which is contained by the circumference of a circle of radius 4 cm., and whose centre is the foot of the perpendicular let fall from the point charge on to the plane, is numerically $\frac{2}{3}$ of the point charge. (Lond. Univ. B.Sc. Hon. Internal., 1909.)

5. Show that if the energy in the electrostatic field is regarded as distributed throughout the field the amount of energy per unit volume at any point P in the field is $\frac{kR^2}{8\pi}$, where k is the specific inductive capacity and R the electric intensity at P . (B. of E. Honours, 1905.)

6. Explain how the forces in the electric field may be regarded as due to tension along the lines of force combined with pressure at right angles to them. (B. of E. Hon., 1906.)

7. Discuss the application of the method of images to the solution of electrostatic problems. (B. of E. Hon. II., 1906.)

8. Show that in passing from one dielectric to another, electric lines of force may undergo a change in direction. (B. of E. 3, 1910.)

9. Compare the forces with which a point charge of electricity and a conducting sphere attract each other (*a*) when the sphere is earthed, (*b*) when it is insulated. (B. of E. Hon. I., 1911.)

10. What is meant by an electrical image? A charge of electricity $+q$ is situated at a distance l from a large earthed plane conducting sheet. Find the distribution of the induced charge in terms of the distance from the point. (Lond. Univ. Ext. B.Sc., 1905.)

11. Can you reconcile Maxwell's system of tensions and pressures in the dielectric medium with the theory which gives the energy per cubic centimetre as $\frac{kE^2}{8\pi}$? (Lond. Univ. B.Sc. Hon. Internal., 1907.)

12. Find an expression for the force per square centimetre of surface on a conductor due to its charge. What charge must there be upon a soap bubble of radius $1\frac{1}{2}$ cm. if the air pressure is the same inside and outside of the bubble, assuming the surface tension to be 27? (Lond. Univ. B.Sc. Hon. Internal., 1907.)

13. Show that if there is no force inside a uniformly charged spherical surface the law of force between two charges e_1 and e_2 is $\frac{e_1 e_2}{r^2}$, where r is the distance between the two points at which e_1 and e_2 are situated. (Lond. Univ. B.Sc. Hon. Ext., 1908.)

14. Find the conditions that hold at the surface separating two media of different resistivity when a current flows from one to the other; and deduce a relation between the inclinations of the lines of flow to the normal on the two sides of the boundary.

15. Show how the induced electrification distributes itself on a conducting sphere placed in a uniform field. (Lond. Univ. B.Sc. Hon. Internal., 1910)

16. Explain the method of electrical images for the solution of problems in electrostatics.

Find the distribution of electricity produced on a conducting sphere insulated without charge, when a point charge is placed near it. (Lond. Univ. B.Sc. Hon. Ext., 1911.)

EXAMPLES VI.

1. Two spheres of radii 5 and 10 cm. respectively have equal charges of 50 units each. They are then joined by a thin wire so that their charges are shared between them. Calculate the total energy before and after sharing. What becomes of the difference of energy? What difference would be caused by bringing the spheres into direct contact with one another? (Lond. Univ. B.Sc. Internal., 1905.)

2. Describe some form of absolute electrometer and give the theory of its action. (Lond. Univ. B.Sc. Hon. Internal., 1907)

3. Define accurately the term *capacity* of a condenser, and show which has the greater capacity, the inside or the outside coating of a Leyden jar.

Find the capacity of a sphere of 15 cms. diameter inside which there is an earthed concentric sphere of 10 cms. diameter. (Lond. Univ. B.Sc. Ext., 1908.)

4. The ends of a metal tube of radius r_1 project into two larger tubes of radii r_2 and r_3 , the radii being small compared with the lengths of the tubes, and the axes being all in the same line. Find the force in dynes on the inner tube when the potentials of the three conducting surfaces are v_1 , v_2 , and v_3 respectively. (Lond. Univ. B.Sc. Hon. Ext., 1908.)

5. A is a gold leaf electroscope, B a quadrant electrometer. For measuring small potential differences B is found to be more sensitive than A; does it necessarily follow that it will be more sensitive for the measurement of small charges? Give reasons for your answer. (B. of E. 2, 1905.)

6. If one pair of quadrants of a quadrant electrometer is connected with the earth, and if a constant charge is given to the other pair of quadrants, the deflections of the electrometer will be a maximum when the potential of the needle has a certain value, any increase of the potential beyond this value diminishing the deflection; explain this result. (B. of E. Honours I., 1905.)

7. How would you determine the specific inductive capacity of a solid substance, being given a slab of the material in question? (B. of E. 3, 1908.)

8. Given a standard condenser of 0.5-microfarad, how would you use it to determine a very small capacity (e.g., about the ten-thousandth part of the standard)? (B. of E. III., 1905.)

9. Describe some method of measuring in electromagnetic measure the capacity of a condenser of considerable capacity. (B. of E. Honours I., 1905.)

10. Describe a method suitable for determining the specific inductive capacity of liquids in rapidly alternating electric fields. (B. of E. 3, 1907.)

11. Deduce an expression for the electrostatic capacity of two coaxial metallic cylinders separated by a layer of air. Investigate the effect of inserting between the cylinders a coaxial cylindrical shell of a dielectric substance of thickness less than that of the layer of air. (Lond. Univ. B.Sc. Hon. Ext., 1906.)

12. State Gauss's theorem, and deduce from it the capacity of a long condenser consisting of two concentric cylinders. (Lond. Univ. B.Sc. Ext., 1909.)

13. Describe some form of quadrant electrometer and deduce a formula for use with it. (Lond. Univ. B.Sc. Ext., 1909.)

14. Two parallel conducting plates are maintained with a constant difference of potential between them. Find the ratio of the attractions between the plates when air is the only medium separating them, and when a sheet of non-conducting material whose thickness is two-thirds of the distance between the plates and whose dielectric constant is 6, is inserted.

15. Describe some form of quadrant electrometer, and discuss the conditions on which the sensitiveness of the instrument depends. (Lond. Univ. B.Sc. Internal., 1911.)

16. A cable consisting of a solid conductor of 6 mm. diameter is surrounded by two layers of insulating material, separated by a thin conducting layer, the inner having a thickness of 3 mm. and a dielectric constant 7, and the other a thickness of 4 mm. and dielectric constant 5. Outside this is an earthed conducting sheath. Find the ratio of the falls of potential in the two insulating layers. On gradually raising the potential difference between the inner conductor and the earthed sheathing, which of the layers will first break down in insulation, assuming the electric strength of the two insulating materials to be the same? (Lond. Univ. B.Sc. Hon. Internal., 1911.)

EXAMPLES VII.

1. Describe some method of determining accurately the specific resistance of an electrolyte. (B. of E. 3, 1906.)

2. Give the elementary theory of the capillary electrometer, and describe its application to the measurement of the potential difference between a solution and mercury. (B. of E. Hon. II., 1906.)

3. Describe the phenomenon of electrolytic conduction and explain how our knowledge of ionic velocities has been obtained. (B. of E. 3, 1907.)

4. Give a short account of the ionic theory of electric conduction in electrolytes, and show why a difference in potential should in general be expected when diffusion of a salt takes place. (B. of E. Hon. I., 1910.)

5. Discuss the relation between the E.M.F. of a cell and the thermal value of the chemical changes which takes place during the passage of the current. (B. of E. Hon. I., 1910.)

6. What is meant by the velocity of an ion in electrolysis, and how has it been measured? (B. of E. 3, 1911.)

7. Describe Kohlrausch's method of determining the resistance of an electrolyte; and explain how from a knowledge of the conductivity of salt solutions, the degree of dissociation of a solution of given strength is usually calculated. (Lond. Univ. B.Sc. Internal., 1906.)

8. Explain how the velocities of the ions in an electrolyte have been ascertained, and describe a method of directly observing an ionic velocity. (Lond. Univ. B.Sc. Hon. Internal., 1906.)

9. Find a relation between the rate of change with temperature of the electromotive force of a reversible cell and the other constants of the cell. (Lond. Univ. B.Sc. Hon. Internal., 1906.)

10. A sphere of unit radius contains a solution of hydrochloric acid in which the density of the acid is 10^{-4} gramme per cubic centimetre. Calculate the electric force in volts per centimetre at the surface of the sphere if one per cent. of the chlorine ions were removed from the solution, the electrochemical equivalent of hydrogen being 0.000104 gramme. (Atomic weight of chlorine = 35.5, hydrogen = 1.01.)

Hence, show that it would be impossible by employing forces of the order of a volt per centimetre to produce any separation of H and Cl ions in the solution

11. Two liquid resistances, A and B, of 5 and 10 ohms respectively, are connected in parallel, and a battery of electromotive force 8 volts and 2 ohms internal resistance is used to send a current through them.

Find the currents in the two liquids, being given that the electromotive force of polarisation is 0.1 volt in A and 1.8 volts in B. (Lond. Univ. B.Sc. Ext., 1908.)

12. Explain how the electromotive force of a cell may be deduced from the quantities of heat evolved in the chemical reactions that take place in the cell, and show that the correction for the temperature-variation of the electromotive force is $T \frac{dE}{dT}$. (Lond. Univ. B.Sc. Hon. Ext., 1908.)

13. Give a short account of the theory of the conductivity of solutions of salts and dilute acids, and mention the principal phenomena which are explained by the theory. (Lond. Univ. B.Sc. Hon. Ext., 1908.)

14. Give an account of experiments to determine the transport numbers for ions in electrolysis. (Lond. Univ. B.Sc. Hon. Internal., 1909.)

15. Show how the velocity of electrolytic ions in an electric field can be calculated from measurement of the specific resistance, and of the transport ratio.

Describe, mentioning necessary precautions, experiments by which this velocity is directly measured. (Lond. Univ. B.Sc. Internal., 1911.)

16. What is meant by the term Solution Pressure used in connection with Voltaic cells? Show how an expression for the electromotive force developed

has been deduced through this conception. (Lond. Univ. B.Sc. Hon. Internal., 1911.)

17. Explain the meaning of the expression “ u and v the mobilities of the ions in electrolysis.”

Show that if in the electrolysis of a solution 10.36×10^{-6} gram equivalents of each ion are liberated by the passage of an ampere for a second,

$$u + v = 10.36 \times 10^{-6}k/N$$

when k is the conductivity of the electrolyte and N the number of gram equivalents of dissolved salt per cubic centimetre of the solution. (Lond. Univ. B.Sc. Ext., 1911.)

EXAMPLES VIII.

1. Describe a method of measuring either the Peltier effect or the Thomson effect of a thermo-couple in absolute measure, and explain how the results are related to the variation of the E.M.F. with temperature. (B. of E. Hon. II., 1906.)

2. Give Kelvin's theory of the thermo-electric circuit, and find an expression for the E.M.F. if the specific heat of electricity varies inversely as the absolute temperature. (B. of E. Hon. II., 1908.)

4. Write a short essay on the use of thermo-couples to measure temperature, taking as an illustration of the method the determination of the temperature at which a molten mixture of two metals solidifies. (B. of E. 3, 1910.)

5. Prove that the coefficient of the Peltier effect at a given junction is the product of the absolute temperature of the junction and the rate of change of the whole E.M.F. of the circuit with the temperature of that junction. (Lond. Univ. B.Sc. Hon. Internal., 1907.)

6. What is meant by the specific heat of electricity? Assuming that the E.M.F. of a circuit of two metals with the cold junction kept at constant temperature varies with the temperature of the hot junction according to a parabolic law, show that the difference of the specific heats of electricity in the two metals is proportional to the absolute temperature. (Lond. Univ. B.Sc. Hon. Internal., 1908.)

7. The thermo-electric power of iron is 1734 micro-volts per degree at 0° and 1247 at 100° , that of copper is 136 at 0° , and 231 at 100° . Construct a thermo-electric diagram for these metals, lead being the standard; and state how the amounts of heat absorbed and given out in the different parts of a copper-iron circuit with its junctions at 0° and 100° , when there is a current of 1 ampere, are shown in the diagram.

Calculate also the electromotive force in volts. (Lond. Univ. B.Sc. Internal., 1911.)

8. Explain clearly what is meant by the “specific heat of electricity.”

Along a metal rod whose area of cross-section is 1 sq. cm. there is a uniform temperature gradient of 1° C. per centimetre. The specific resistance of the material of the rod is 150 microhms per cm. cube. When a current of 0.05 ampere is sent from the hot to the cold end the temperature gradient is unaltered. Calculate the specific heat of electricity for this metal. (Lond. Univ. B.Sc. Internal., 1910.)

9. The E.M.F. in a simple thermo-electric circuit, one junction of which is heated while the other is kept at 0° C., is given by the expression $E = bt + ct^2$, where t is the temperature of the hot junction. Determine the neutral temperature, and the Peltier and Thomson effects in the circuit.

Explain the theory on which these determinations are made. (Lond. Univ. B.Sc. Hon. Internal., 1911.)

EXAMPLES IX.

1. Distinguish between a ballistic and a dead-beat galvanometer. Describe some form of suspended coil galvanometer stating the conditions under which it is (1) dead beat or (2) ballistic (B. of E. 2, 1905.)

2. In what way may a circuit carrying a current be considered equivalent to a magnetic shell? Find the work done in taking a magnetic pole round a closed curve which threads an electric circuit once. (B. of E. 3, 1909.)

3. Prove the formula for calculating the magnetic field inside a long helix at points distant from the ends. Suggest a method for measuring the field inside experimentally. (Lond. Univ. B.Sc. Internal., 1905.)

4. Find an expression for the magnetic potential at any point due to an electric current flowing round a closed circuit. Hence, or otherwise, calculate the galvanometer constant of the Helmholtz form of tangent galvanometer, in which two coils are placed parallel to each other at a distance apart equal to the radius of either. (Lond. Univ. B.Sc. Internal., 1908.)

5. Find the magnetic moment of a sphere of soft iron of permeability μ placed in a uniform magnetic field of strength H . (B. of E. Hon. I., 1905)

6. An electric current of one ampere flows round a circular metal ring, the radius of which is 10 cms. Determine the strength and direction of the magnetic field at a point on the line drawn through the centre of the ring perpendicular to its plane and 10 cms. distant from the plane of the ring. (B. of E. 2, 1908.)

7. Show that a uniformly magnetised sphere produces the same effect at external points as that produced by a small magnet at the centre of the sphere. (B. of E. 3, 1908.)

8. Compare the relative advantages of different forms of sensitive galvanometer, and discuss the condition upon which the sensitiveness depends. (B. of E. Hon. II., 1908.)

9. Two circular coils of wire are placed with their planes parallel to each other at a distance of 5 cms. apart. The larger coil has a radius of 10 cms. and 30 turns of wire, the smaller a radius of 2 cms. and 20 turns of wire. Calculate approximately in grammes weight the mechanical force between the coils when a current of 1 ampere is passed through both, proving any formula used.

Show how the principles thus illustrated are applied practically in the ampe-balance. (Lond. Univ. B.Sc. Hon. Ext., 1906.)

10. Find an expression for the mutual potential energy of a magnetic shell and an external magnetic system. Show that if the shell forms a closed surface it will exert no action on a magnet inside it. (Lond. Univ. B.Sc. Hon. Internal., 1910.)

11. Explain what is meant by a simple magnetic shell, and find the potential of such a shell at any point.

Calculate the magnetic force at a point inside a long solenoid of n turns per centimetre carrying a current of A amperes. (Lond. Univ. B.Sc. Ext., 1910.)

12. Find the law of refraction of magnetic lines at a surface at which the permeability of the medium changes.

Draw incident and refracted lines for media whose permeabilities are in the ratio 1.5, when the incident line makes an angle of 45° with the normal to the surface (a) in the medium (1), (b) in the medium (2). (Lond. Univ. B.Sc. Hon. Ext., 1910.)

EXAMPLES X.

1. In what respects do the magnetic properties of iron and steel differ? Define the terms intensity of magnetisation (I), induction (B), and magnetic force (H). How do you obtain the relation

$$B = H + 4\pi I,$$

either theoretically or experimentally? (Lond. Univ. B.Sc. Ext., 1907.)

2. Show in what features a magnet circuit is analogous to an electric circuit. In what respects does the analogy fail? (Lond. Univ. B.Sc. Internal., 1907.)

3. Show that the work per cubic centimetre performed in taking a specimen of iron through a cycle of magnetisation is represented by the area of the cycle upon the H - I diagram. Describe how the energy loss due to hysteresis may be determined for a given material. (Lond. Univ. B.Sc. Hon. Internal., 1907.)

4. Define magnetic induction B and magnetising force H , and give an account of an experimental method of determining their relation for a specimen of soft iron. (Lond. Univ. B.Sc. Internal., 1909.)

5. Explain what is meant by residual magnetism, coercive force, permeability.

Draw a curve showing the manner in which the magnetism induced in a soft iron rod varies as the magnetising field is taken through a cycle, and state in a general way how from this diagram you would obtain the residual magnetism, coercive force, and permeability of the iron. (B. of E. 2, 1911.)

6. Define magnetic force H and magnetic induction B . Show that the energy per unit volume of the magnetic field between two plane poles is given by $\frac{BH}{8\pi}$. (Lond. Univ. B.Sc. Ext., 1905.)

7. Give an account of Ewing's theory of magnetism. In what respect does it differ from Weber's? (Lond. Univ. B.Sc. Hon. Internal., 1905.)

8. Discuss the effects of and the methods of dealing experimentally with free magnetism in the measurement of magnetic permeability. Find an expression for the effect of a thin radial crevasse upon the magnetisation of an anchor ring. (Lond. Univ. B.Sc. Hon. Internal., 1906.)

9. What is the general character of the magnetic permeability of iron (α) in very strong, (b) in very weak fields? How has the latter been experimentally investigated? (Lond. Univ. B.Sc. Hon. Internal., 1906.)

10. What is meant by hysteresis, and by a cycle of magnetisation?

Prove that the area of the H , B cycle denotes 4π times the energy dissipated per c.c. of metal during each magnetic cycle. (Lond. Univ. B.Sc. Internal., 1910.)

11. A long solenoid of ten turns to the centimetre contains an iron rod 2 cm. diameter cut in two. Find the force necessary to separate the two halves of the rod when a current of 3 amperes is flowing in the solenoid; given that on reversing this primary circuit 60 micro-coulombs flow through a secondary circuit of ten turns wound round the iron rod, and having a total resistance of 100 ohms. (Lond. Univ. B.Sc. Internal., 1911.)

12. Describe the effect of temperature on (1) the magnetic permeability of iron under small magnetising forces; (2) the maximum intensity of magnetisation of the iron. (B. of E. 2, 1905.)

be determined for a given material. (Lond. Univ. B.Sc. Hon. Internal., 1907.)

4. Define magnetic induction B and magnetising force H , and give an account of an experimental method of determining their relation for a specimen of soft iron. (Lond. Univ. B.Sc. Internal., 1909.)

EXAMPLES XI.

1. Define the coefficient of self-induction of a circuit. Calculate approximately the coefficient of self-induction of a long straight cylindrical solenoid of radius r and length l , wound uniformly with N turns of wire per unit length. (B. of E. 3, 1906.)

2. Discuss the production of electric oscillations in a circuit containing capacity and self-induction, and find the effect of damping on the frequency. (B. of E. Hon. 3, 1906.)

3. Describe a method of determining the coefficient of self-induction of a coil, and give the theory of the method described. (B. of E. Hon. II., 1909.)

4. Define "self-inductance of a circuit," and describe in detail any two phenomena which depend upon it. (Lond. Univ. B.Sc. Internal., 1905.)

5. Give an account of the solution of net-work problems in current conduction, and apply your method to the division of the discharge of a condenser through ballistic galvanometer shunted by a non-inductive resistance. (Lond. Univ. B.Sc. Hon. Internal., 1905.)

6. Assuming the equation

$$Ri = E - nS \frac{dB}{dt}$$

for the current i in a solenoid of n turns wound round a long iron bar of section S , show that $B = H + 4\pi I$, where I is the intensity of magnetisation of the iron and H the magnetic force due to the current in the solenoid. (Lond. Univ. Ext., Hon., 1908.)

7. A solenoidal coil 70 cm. in length, wound with 30 turns of wire per centimetre, has a radius of 4.5 cm. A second coil of 750 turns is wound upon the middle part of the solenoid. Calculate the coefficient of self-induction of the solenoid and the coefficient of mutual induction of the two coils. Will the inductance of the solenoid be affected by short circuiting the ends of the secondary coil? (Lond. Univ. B.Sc. Internal., 1909.)

8. Find whether the discharge of a condenser through an inductive circuit is oscillatory when

- (a) Capacity = 2 micro-farad, $L = 0.15$ henry, and $R = 150$ ohms
 (b) $C = 1.5$ m.f., $L = 0.015$ hy., and $R = 1000$ ohms
 (c) $C = 10_{-6}$ m.f., $L = 0.0125$ hy., and $R = 100$ ohms

and when oscillatory, find the frequency.

9. Find approximately the frequency of oscillation when a condenser of 0.75 microfarad capacity discharges through a circuit consisting of a solenoid of 1200 turns and length 80 cms. wound upon a long iron rod of diameter 0.75 cm. and permeability 850.

EXAMPLES XII.

1. Two points, to which an alternating E.M.F. is applied, are connected by a circuit containing capacity and inductance, describe a graphic method by which the current and its lag behind the E.M.F. may be determined.

Example.—E.M.F. = 200 volts, frequency = 50, resistance = 10 ohms, inductance = 0.1 henry, capacity = 1 microfarad. (B. of E. 3, 1905.)

2. Distinguish between the mean value and the root mean square value of an alternating current, and find the relation between them.

Prove that the power absorbed by a coil traversed by an alternating current is $EC \cos \theta$, where E and C are the root mean square values of the E.M.F. and current respectively, and θ is the difference in phase between these two quantities. (B. of E. 3, 1908.)

3. Find an expression for the current at any moment in a circuit of given resistance and self-inductance when subject to a simple harmonic E.M.F. (B. of E. Hon. I., 1908.)

4. Explain why the primary current in a transformer, such as an ordinary house transformer, is so much greater when the secondary circuit is closed. (B. of E. Hon. I., 1911.)

5. Explain how telephone currents may be measured experimentally. What function of the current is it that is directly determined? (Lond. Univ. B.Sc., 1904.)

6. Describe Kelvin's ampere-balance, and explain its advantages as a standard for calibrating ammeters and voltmeters for alternating currents. (Lond. Univ. B.Sc. Hon. Ext., 1907.)

7. Explain the apparent increase in resistance of a wire with the frequency for a rapidly alternating current. (Lond. Univ. B.Sc. Hon. Internal., 1907.)

8. Describe the construction of an electrostatic voltmeter. An electrostatic voltmeter gives deflections of 15, 18, and 21 scale divisions for constant potentials of 50, 60, and 70 volts respectively. What deflections will be produced by an alternating electromotive force $E \sin pt$ (a) when the amplitude E is 70 volts, and (b) when E is 90 volts? (Lond. Univ. B.Sc. Ext., 1908.)

9. Show that two alternating magnetic fields at right angles to each other may be made equivalent to a rotating field, and explain how this has been utilised in the construction of electric motors. (B. of E. Hon. I., 1910.)

10. What is meant by *impedance*? Show how to calculate the current which passes through a circuit on applying a given alternating E.M.F., the resistance and inductance being known. (B. of E. Hon. I., 1910.)

11. Describe a method of measuring the self-induction of a coil depending on the use of an alternating current, particularly mentioning any precautions necessary to secure correct results. (B. of E. Hon. I., 1910.)

12. Describe in detail some form of oscillograph suitable for determining the wave form of an alternating current. (B. of E. 3, 1911.)

13. Discuss the difficulties encountered in making an accurate determination of the power given to an inductive circuit such as the primary of a transformer, and describe some satisfactory method of making the measurement. (Lond. Univ. B.Sc. Hon. Ext., 1909.)

14. An alternating E.M.F. of 200 volts and 50 periods per second is applied to a condenser in series with a 20 volt 5 watt metal filament lamp. Find the capacity of the condenser required to run the lamp. (Lond. Univ. B.Sc. Hon. Internal., 1910.)

15. Show how the closing of the secondary circuit affects the phase and current in the primary of an ironless transformer due to an applied alternating electromotive force. (Lond. Univ. B.Sc. Hon. Internal., 1911.)

EXAMPLES XIII.

1. Describe carefully one method for determining the ohm in absolute measure. (B. of E. Hon. II., 1908.)

2. What is meant by the expression "the dimensions of a physical quantity"?

Taking as your fundamental quantities time, length, and force, deduce the

dimensions of energy and electrostatic potential. (Lond. Univ. B.Sc. Ext., 1905.)

3. Deduce the dimensions in terms of those of mass, length, and time, of quantity, potential difference, and capacity, both in the electrostatic and electromagnetic systems. Show that the ratio is expressed by some power of a velocity, and that, to reduce this ratio to a pure number, it is necessary to include the dimensions in dielectric constant and permeability. (Lond. Univ. B.Sc. Hon. Internal., 1905.)

4. Determine the dimensions of electric resistance in electrostatic and in electromagnetic units, and the condition of their identity. (B. of E. 3, 1905.)

5. Give Lorenz's method of determining the ohm in absolute measure, and describe in detail the apparatus required for the purpose. (B. of E. Hon. I., 1906.)

6. Examine the dimensions of the quantity $k\mu$, where μ denotes permeability and k specific inductive capacity. How is the value of the quantity $k\mu$ practically determined? (B. of E. 3, 1907.)

7. How is it that the ratio of the electromagnetic units to the electrostatic units is so intimately connected with the velocity of light? (B. of E. Hon. I., 1908.)

8. Describe some one method of determining experimentally the quantity " v " involved in the ratio of the two systems of electric units, explaining the precautions necessary for an accurate result. (Lond. Univ. B.Sc. Hon. Ext., 1906.)

9. Describe some methods by which the units of current and electromotive force may be found in the electromagnetic system. (Lond. Univ. B.Sc. Ext., 1907.)

10. According to the usual definitions, the dimensions of capacity on the electromagnetic system are those of the reciprocal of an acceleration, while on the electrostatic system they are simply a length. Show how these results are obtained, and explain the apparent discrepancy. (Lond. Univ. B.Sc. Internal., 1908.)

11. Define the terms—magnetomotive force, magnetic flux, and reluctance of a magnetic circuit. Find the dimensions of these quantities. (Lond. Univ. B.Sc. Hon. Internal., 1909.)

EXAMPLES XIV.

1. How has it been shown experimentally that the current in discharging a condenser may be alternating in character?

Explain shortly how this fact has been utilised for telegraphing through space without wires. (B. of E. 3, 1910.)

2. Write a short essay on the production of tuned trains of electrical waves and their employment in wireless telegraphy. (B. of E. Hon. I., 1911.)

3. Give a short account of how the wave-length of electromagnetic waves in air has been determined. (Lond. Univ. B.Sc. Internal., 1906.)

4. What method would you adopt to determine the dielectric constant of a slightly conducting liquid? (Lond. Univ. B.Sc. Hon. Internal., 1907.)

5. Discuss the phenomenon of the "singing arc" and describe how it has been utilised for generating electromagnetic waves. (B. of E. Hon. I., 1907.)

6. An electric current oscillates in a circuit, the frequency being of the order 10^6 . How would you determine the strength of the current? (B. of E. 3, 1908.)

7. Prove that in a plane electromagnetic wave both the electric force and the magnetic force are in the wave front and in directions at right angles to one another. (B. of E. Hon. I., 1908.)

8. Show that the discharge of a condenser is in general oscillatory, and describe one method by which the period of the oscillations may be measured. (B. of E. Hon. I., 1909.)

9. Describe experimental methods of finding the velocity of electromagnetic waves along wires. (Lond. Univ. B.Sc. Hon. Ext., 1907.)

10. Write down the fundamental equations of the electromagnetic field, and deduce from them the velocity of propagation of a plane electromagnetic wave in a medium of dielectric constant k and permeability μ . (Lond. Univ. B.Sc. Hon. Internal., 1907.)

11. Describe the production of electromagnetic waves by means of Hertz's oscillators, and show that there is necessarily a relative change in phase of the electric and magnetic components accompanying the progress of the disturbance outward from the oscillator. (Lond. Univ. B.Sc. Hon. Internal., 1907.)

12. Describe any three methods of detecting electric oscillations, and discuss their relative advantages. (Lond. Univ. B.Sc. Hon. Internal., 1908.)

13. Write down and criticise the expressions usually employed to represent the electrostatic and electrokinetic energy in an electromagnetic field.

Deduce Poynting's method of representing the flow of energy in the field. (Lond. Univ. B.Sc. Hon. Ext., 1909.)

14. Show that the magnetic effects of a current may be regarded as due to the motion of the Faraday tubes, and find the paths along which the energy travels. (Lond. Univ. B.Sc. Hon. Internal., 1910.)

EXAMPLES XV.

1. Describe experiments which show that the cathode rays are small particles charged with negative electricity. How has the velocity of these rays been determined? (B. of E. 3, 1906.)

2. Describe some method of measuring the velocity of the ions in gases. (B. of E. Hon. I., 1906.)

3. Give a brief account of the principal phenomena of cathode rays, and explain how the charge carried has been experimentally determined. (B. of E. Hon. II., 1907.)

4. Describe the mode of production of Röntgen and Lénard rays, and discuss the possible origin of the phenomenon. (B. of E. 3, 1909.)

5. Give a short account of the principal phenomena to be noted in connection with the passage of electricity through gases at reduced pressures. (B. of E. 3, 1911.)

6. How may the electrical conductivity of an ionised gas be determined? What is meant by the saturation current? (Lond. Univ. B.Sc. Ext., 1905.)

7. Describe the general character of the discharge in a partially exhausted tube. (Lond. Univ. B.Sc. Hon. Internal., 1905.)

8. Give two methods of finding the ratio of electric charge to mass in the case of an ion in a gas. (Lond. Univ. B.Sc. Hon. Internal., 1906.)

9. Find the conditions that the effect of a charge situated upon a small spherical drop shall be equal and opposite to that due to surface tension. (Lond. Univ. B.Sc. Hon. Internal., 1906.)

10. An electrified particle traverses an electric field, the intensity of the field being normal to the original direction of motion of the particle. Find an expression for the deflection of the particle.

What other experiments must be made in order to determine the ratio of the mass of the particle to its electric charge? (Lond. Univ. B.Sc. Ext., 1906.)

11. Two metallic plates, separated by a layer of air, are connected with the

opposite poles of a battery, in which the number of cells can be increased indefinitely. Trace the change in the relation between potential difference and the current, explaining those changes in terms of the ionisation theory.

How would you measure experimentally the currents in such a case? (Lond. Univ. B.Sc. Hon. Ext., 1906.)

12. Explain the form of the curve connecting the electromotive force and the current in a gas at low pressure which is ionised by Röntgen rays.

How would you show that for certain electric forces the negative ions produce others by collisions with the molecules of the gas, while the positive ions do not increase the ionisation? (Lond. Univ. B.Sc. Hon. Ext., 1907.)

13. Give an accurate account of some phenomena in gases which differ for positive and negative electricity, and explain the physical properties of the ions to which the phenomena may be attributed. (Lond. Univ. B.Sc. Hon. Ext., 1908.)

EXAMPLES XVI.

1. Write an essay on radium, in particular discussing the changes which this substance is supposed to undergo. (B. of E. Hon. I., 1908.)

2. Describe experiments by which the nature of the rays emitted by radium can be determined. (B. of E. Hon. I., 1911.)

3. Give an account of the various kinds of radiation emitted by a solid compound of radium, explaining how the properties of the different rays may be investigated experimentally. (Lond. Univ. B.Sc. Hon. Ext., 1906.)

4. Give an outline of the theory of the disintegration of radioactive materials, and deduce equations showing the amounts of two consecutive products present at any time subsequent to the isolation of the higher product. (Lond. Univ. B.Sc. Hon. Internal., 1909.)

5. Give an account of the principal experiments to which we owe our knowledge of the α particle. (Lond. Univ. B.Sc. Hon. Ext., 1909.)

6. Describe a method of determining the quotient of the mass by the charge of an electron.

Show that the value of this quotient may depend on the velocity of the electron, and describe experimental work dealing with this effect. (Lond. Univ. B.Sc. Hon. Ext., 1909.)

EXAMPLES XVII.

1. Write an essay on the application of the electron theory to the explanation of electric conductivity. (B. of E. Hon. I., 1907.)

2. Describe the Hall effect, and discuss the theory which has been advanced to account for it on the hypothesis of electrons. (B. of E. Hon. I., 1908.)

3. Explain why there is an apparent increase in mass produced by charging a body with electricity. (B. of E. Hon. I., 1908.)

4. Find the magnetic field due to a point charge moving with uniform velocity; the velocity of the point being small compared with that of light. (B. of E. Hon., 1905.)

5. Give a short account of the Zeeman effect, and of its explanation on the electronic hypothesis. (B. of E. Hon. I., 1909.)

6. What grounds are there for taking a moving charge of electricity as equivalent to a current? (B. of E. 3, 1911.)

7. Distinguish between diamagnetic, paramagnetic, and ferromagnetic substances, giving the characteristic differences which make it necessary for these divisions. (B. of E. Hon. I., 1911.)

8. Give a theory of the production of Röntgen rays, and discuss how it explains the leading experimental results. (Lond. Univ. B.Sc. Hon. Ext., 1909.)

INDEX

A

α particles, charge on the, 518
 —, number emitted by radium, 517
 α rays, 501
 —, absorption of, 503
 —, in magnetic field, 502
Abraham, M., 527
 Absorption, electric, 167
 —, α , β , and γ rays, 501
 Accumulators, 200
 Actinum, 500
 Age of earth and sun, 517
 Agonic line, 34
Allen, H. S., 477
Allen, S. J., 523
 Alloys, magnetic, 283
 Alternating current, 343
 — — — measurements, 347
 — — — power, 349
 Amalgam concentration cells, 194
 Ampere balance, 244
 — (unit of current), 61
Ampère's theorem, 52, 225
 Amplifying valve, 493
Anderson, Prof. A., 329
 Annual variation, 38
 Anomalous dispersion, 542
 Antenna, 439
Arago's disc, 251
 Arc, singing, 444
 —, *Poulsen*, 445
Arons, L., 169
Arrhenius, S., 175, 495
 Astatic couple, 77
 Atmosphere, ionisation in, 493
 Atmospheric radioactivity, 521
 Attracted disc electrometer, 156
 Audion, 495
 Aurora Borealis, 41
Ayton, W. E., 84, 170, 325

B

β rays, 501
 —, charge of, 506
 —, v and $\frac{e}{m}$, 504

Back electromotive force, 174
Baedeker, K., 557
Baily, F. G., 291
 Ballistic galvanometer, 252, 253
 — — —, calibration of, 256
 — — —, determination of B , 274
 — — — method (cycle), 275
 Bar and yoke, double, 297
 — — — tests, 296
Barkla, Prof. C. G., 471
Barnes, H. T., 516
 Battery resistance, 99, 105
 —, secondary, 200
Bauer, L. A., 41
Becquerel rays, 497
Belloc, G., 219
Bezold, v., 40
Bidwell, S., 289
Birot and Savart, 52
Bjerknes, V., 447
Blondlot, R., 435, 470
 Bolometer, 441
Boltzmann, L., 165, 170, 537
 Boundary conditions, 140, 234
Boys' radio-micrometer, 221
Bragg, Prof. W. H., 503
 Bridge, metre, 93
 — —, permeability, 299
 British Association ohm, 398
Broca galvanometer, 77

C

Cable, waves in, 449
 Cadmium cell, 190
 Calibration of galvanometer, 76, 256
 — of metre bridge, 94
Callendar, Prof. H. L., 97, 222
 Calorie, 62
Campbell, A., 315, 380
 Canal rays, 488
 Capacities, comparison of, 162, 164, 325, 379
 Capacity, 124, 149, 353
 —, by repeated sharings, 163
 —, measurement of, 257, 393

- Capacity, of concentric spheres, 149
 —, sphere, 149
 Capillary electrometer, 199
 Cardew voltmeter, 88
 Carey-Foster, Prof. G., 95
 Carr, W. R., 465
 Cassie, W., 170
 Cavendish proof of inverse square law, 118
 Coils, 102
 —, concentration, 190
 —, resistance of, 99, 105
 —, secondary, 200
 —, standard, 189
 C.G.S. system of units, 382, 396
 Changes, radioactive, 508
 Characteristic X-rays, 561
 Charge of a particle, 518
 — of β rays, 506
 — of condenser, 331
 —, moving, and current, 527
 — moving with velocity of light, 530
 — on negative ion, 486
 — suddenly stopped, 531
 Charged sphere, mass of, 525
 Choking coil, 355
 Chree, C., 39
 Circuit, divided, 318
 —, magnetic, 291
 —, with capacity, inductance and resistance, 353
 Circular current and magnetic field, 53, 227
 Closed conducting surface, 128
 — oscillator, 443
 Coaxial coils, 242
 — cylinders, capacity of, 150
 — —, inductance of, 307
 Cobalt, 277
 Coefficient of coupling, 463
 — of increase of resistance, 64, 552
 — of self-induction, 302
 Coercive force, 276
 Coherer, 440
 Cohn, E., 169
 Coil, choking, 355
 —, induction, 319
 — in rotating field, 372
 — suspended, 240
 Coils, coaxial, 242
 Collision, ionisation by, 490
 Combination of capacities, 152
 — resistances, 62
 Comparison of capacities, 325, 379
 — of capacity and inductance, 326, 327, 329, 380
 — of inductances, 324
 Compass, prismatic, 20
 —, Kelvin, 44
 Compensation of deviation, 49
 Concentration cells, 190
 — —, E.M.F. of, 192
 Concentric spheres, capacity of, 149
 Condensation of water vapour, 482, 484
 Condenser, charge and discharge, 309
 —, cylindrical, 150
 —, guard-ring, 153
 —, high resistance by, 312
 —, parallel plate, 150
 —, sliding, 155
 Condensers, 151
 — in parallel, 152
 — in series, 153
 Conditions, boundary, 140, 234
 Conductance, 60
 Conduction, electrical, 551
 — in ionised gas, 478, 508
 Conductivity, 63
 —, equivalent, 176
 —, measurement of, 184
 — of pure metals, 552
 —, thermal, 552, 560
 Conductors, 536
 Constant, dielectric, 119, 166, 171, 536
 —, radioactive, 511
 Controlling magnet, 76
 Cooke, H. L., 523
 Copper voltmeter, 67
 Corpuscles, negative, 469
 Corpuscular rays, 471
 Cosser condenser, 155
 Coulomb's law, 128
 — torsion balance, 116
 Coupling, coefficient of, 463
 Critical temperature, 286
 Crompton potentiometer, 107
 Crookes, Sir W., 421, 466, 502, 508
 Crystal detector, 442
 Curie, J. and P., 224
 Curie, Mme., 500, 506, 507, 515, 521
 Curie, P., 287, 471, 500, 506, 515, 548
 Curie's law, 438
 Current and magnetic shell, 225, 236
 — and pole, force between, 389
 — by potentiometer, 104
 — displacement, 409
 —, effect of current on, 241, 390
 —, growth of, 303
 —, idle or wattless, 350
 — in magnetic field, 237
 —, saturation, 479
 —, unit of, 53, 396, 404
 —, virtual, 348
 Cycle by ballistic method, 275
 — of magnetisation, 273, 276
 Cylinder, intensity near, 127
 Cylindrical condenser, 150
 Cymometer, 459

D

δ rays, 507
Daily variation, 38
Damping, 255
 — of oscillations, 446
 —, resistance by, 258
Danell's cell, 102
Dark space, *Crookes'*, 466
d'Arsenal galvanometer, 80
Dead beat charge, 333
 — — discharge, 338
 — — galvanometer, 341
Debierno, A., 500
Decay of current, 306
 — of ionisation, 479
Declination, 19, 20
De la Rue, 438
De la Rue, W., 466
Demagnetisation, 268
Demagnetise a specimen, to, 277
de Sauty, 325
Detector, crystal, 442
 —, magnetic, 442
 —, thermal, 441
Deviation (due to ship's iron), 45
 —, causes of, 46
 —, compensation of, 49
 —, equation for, 48
Dewar, Sir J., 516, 548, 552
Diagram, vector, 345
 —, transformer, 361
Diamagnetism, 544
Dielectric, 119, 536
 — constant, 119, 536
 — and capacity, 151
 — and temperature, 170
 — by oscillations, 461
 —, gases, 170
 —, table of, 171
Diesselhorst, H., 554
Dimensions, 383
Dip, 19, 20, 31
Discharge of condenser, 337
 —, oscillatory, 339, 423
 —, process of, 493
 —, rate of, 340
 —, spark, 464
Dispersion, anomalous, 542
 — and refraction, 537
Displacement, electric, 130
 — current, 409
Dissociation, electrolytic, 175
Distribution of charge on conductor, 137
Divided circuits, 318
Dolezalek electrometer, 161
Doppler effect, 489
Double bar and yoke, 297

Dropping electrode, 197

Drude, P., 549, 552
Dry cell, 102
Drysdale, C. V., 299
du Bois, H., 235, 544
Duddell, W., 80, 356, 444

E

Earth inductor, 261
Edison effect, 492
Electric absorption, 167
 — displacement, 130
 — intensity, 117
 — potential, 120
Electrical conduction, 551
 — images (plane), 145
 — (sphere), 146
 — units, 385
Electro-chemical equivalent, 65,
 172
 — of silver, 403
Electro-dynamometer, 246
Electrolysis, 65, 172
Electrolytic conductivity, 184
 — dissociation, 175
 — interrupter, 445
Electromagnetic induction, 247
 — repulsion, 369
 — shielding, 367
 — system of units, 386
 — theory of light, 391
Electrometer, attracted disc, 156
 —, capillary, 199
 —, quadrant, 157
Electromotive force, 58
 — forces, comparison of, 102
Electron, 475
 —, charge of, 486
Electronic theory of light, 533
Electrons, temperature equilibrium,
 549
Electrophorus, 114
Electroscope, 110, 498
Electrostatic system of units, 386, 388
 — voltmeter, 161
Eleven-year period, 40
Elster, J., 491, 521
 — of thorium, 514
 —, volume of, 515
Energy in concentration cell, 191
 — in dielectric, 131
 — of charge, 123
 — of wave, 416
Equipotential surfaces, 15, 122
Equivalent conductivity, 176

Equivalent conductivity (table), 177
 — length of magnet, 24
Eschenhagen, M., 42
Ettinghausen effect, 558
Ettinghausen, Nernst and, effect, 557
Eve, A. S., 523
Ewing, Prof. J. A., 266, 271, 276, 280,
 284, 285, 287, 290, 297, 299

F

Farad, 312, 396
Faraday (dielectric constant), 162
 — (ice-pail experiments), 112
 — (laws of electrolysis), 65
 — dark space, 466
 — effect, 542
 — tubes, 524
 — —, motion of, 414
Faure cell, 202
 Ferromagnetism, 545
 Fictitious surface density, 141
 Field due to charge, 117
 — — to magnet, 3, 17
 Figure of merit of galvanometer, 81
 Flames, ionisation in, 495
Fleming, Prof. J. A., 221, 239, 249, 442,
 458, 459, 548, 552
Flanders' bar, 50
 Fluorescence by α rays, 502
 Fluxmeter, 263
 Force between charges, 117
 — — magnets, 15
 — on charged surface, 132
 — on current in magnetic field, 237
 — on magnetic body, 235
 — on uncharged body, 139
 Frequency, high, resistance and in-
 ductance, 364
 — of oscillation, 336

G

γ rays, 501, 507
 —, origin of, 532
 Galvanometer, ballistic, 252
 —, calibration of, 76, 256
 —, figure of merit of, 81
 — resistance, 83, 98
 — shunts, 84
 —, suspended coil, 78
 —, tangent, 54
 —, vibration, 380
 Gases, dielectric constant of, 170, 537
Gauss, C. F., 9, 37
Gauss's law, 125, 233, 406

Gauss, the, 386
Geiger, H., 517
Geitel, H., 491, 521
Gilbert, Dr., 37, 111
Glazebrook, R. T., 395, 408
Gockel, A., 523
Goldstein, E., 488
Gott's test, 165
 Gramme-equivalent, 172
Grassot fluxmeter, 263
 Growth of current, 303, 334
 Guard-ring condenser, 153

H

Hadfield's manganese steel, 283
Hall effect, 556
Hallwachs, W., 475
Hankel (pyro-electricity), 224
 "Hard" X-rays, 470
Harker, J. A., 77, 492
 Heat emission by radium, 515
Heaviside, O., 52, 454, 526, 530
 Heeling error, 49, 50
Helmholtz, H., 57, 189, 190, 198, 517
 Henry, the, 308
Hertz, H., 435
Hubbert magnetic standard, 263
 High frequency circuits, 456
 — resistance by leakage, 312
Hutton, W., 179
Hoffmann's tube, 66
Hopkinson, J., 168, 286, 296
 Horizontal variometer, 42
 Horse-power, 61
 Hot bodies, ionisation by, 493
 Hot-wire instruments, 88
Hull, G. F., 420
 Hysteresis, 276
 —, work due to, 278
 — tester, 281

I

Ice-pail experiments, 112
 Idle current, 350, 354
 Images, electrical, 145
 Imaginary quantities, 376
 Impedance, 346, 354
 Index of refraction, 421
 Inductance, 302, 353
 —, high frequency, 364
 —, measurement of, 322, 349, 379
 —, mutual, 313
 — of coaxial cylinders, 307
 — of solenoid, 307

Inductance, standards of, 309, 315
 Induction coil, 319
 —, electrical, 125
 —, electromagnetic, 247
 —, magnetic, 233, 267
 —, tubes of, 129, 234
 Inductor, earth-, 261
 Insulation resistance, 91
 — by leakage, 312
 Insulators, 356
 Intensity, electrical, 117
 —, magnetic, 3
 — of magnetisation, 266
 Interrupter, mercury, 446
 —, *Wehnelt*, 445
 Inverse square law, 2, 9, 117
 Ionic conductivity, 184
 — velocities, 181, 183
 Ionisation, 477
 — by *Becquerel* rays, 497
 — by hot bodies, 491
 — by impact, 490
 —, decay of, 479
 — in flames, 495
 Ionised gas, conduction in, 478
 Ionium, 515
 Ions, migration of, 179
 Iron and steel, 277
 — — — alloys, 283
 Isoclinals, 34
 Isodynamic lines, 34
 Isogonals, 34
 Isthmus method, 285

J

Jäger, *W.*, 554
Jahn, *H.*, 189
 Joule, the, 61
Joule's equivalent, 62

K

Kathode dark space, 466
 — rays, 468, 471
Kaufmann, *W.*, 504, 527
Kaye, *G. W. C.*, 492, 499
Kelvin, *Lord*, 44, 77, 98, 100, 145, 153,
 156, 164, 206, 244, 245, 289, 339, 454,
 517
Kerr effect, 544
 Kew dip circle, 32
 — magnetometer, 26
Kirchhoff, *G.*, 402
Kirchhoff's laws, 69
Kleeman, *R.*, 503

Klemencic, *I.*, 422
Koenigsberger, *J.*, 548
Kohlrausch, *F.*, 175, 181, 185, 186

L

Laborde, *A.*, 515
 Lag in magnetisation, 284
Landolt, *H.*, 170
Langevin, *P.*, 544
Laplace, 132
Larmor, *J.*, 533
Latmer-Clark cell, 190
Laue, *M.*, 562
Lebedef, *P.*, 420
Lecher's wires, 458, 462
Leclanché cell, 102
Leduc effect, 558
 Left-hand rule, 239
Lenard, *P.*, 559
Lenz's law, 250
 Leyden jar, 151
 Life of radium, 519
 Limitations of Maxwell's theory, 136
 Limiting case in discharge, 336, 340
 Line integral of field, 231
 Lines of force, electric, 129
 — — — magnetic, 11
Lippmann, *G.*, 199
Lodge, *Sir O. J.*, 183, 395, 434, 438, 44C
 Longitudinal effects, 558
Lorentz, *H. A.*, 533, 537
Lorenz, *L.*, 400
 Low resistance, 99

M

McClelland, *Prof J. A.*, 492
 Magnet, vibrating, 21, 23
 Magnetic circuit, 291
 — curve tracer, 283
 — detector, 442
 — flux standards, 262
 — induction, 233, 260, 267
 — intensity, 3, 233
 — map, 35
 — meridian, 19
 — moment, 4
 — permeability, 333
 — resistance, 293
 — shell, 52, 225, 236
 — shielding, 23
 — storms, 40 5
 — susceptibility, 267
 Magnetisation, effect of tapping on, 277
 — and mechanical stress, 287
 — and temperature, 286

Magnetisation in strong fields, 285
 —, intensity of, 266
 — in weak fields, 283
 —, molecular theory of, 289
 — of iron and steel, 277
 —, time lag of, 284
 Magnetographs, 41
 Magnetometer, 5
 —, *Ewing*, 271
 —, *Kew*, 26
 —, reflecting, 8
 Magneton, 548
 Magneto-motive force, 292
 Magneto-striction, 289
 Mance (battery resistance), 99
 Manganese steel, 283
 Map, magnetic, 35
 Marconi, *G.*, 439, 443
 Mass of charged sphere, 525
 Mather, *T.*, 84, 404
 Maxwell, the, 387
 Maxwell, *James Clark*, 118, 136, 249, 326,
 330, 360, 387, 393, 409, 420, 524, 545
 Maxwell's rule, 249
 Mean free path, 551
 Measurement of capacity, 257, 393
 — of damping, 446
 — of inductance, 332, 349
 — of low resistance, 99
 — of magnetic induction, 260
 — of resistance, 90
 — of thermal E.M.F.'s, 219
 Mechanical stress and magnetisation,
 287
 Mercury interrupter, 446
 Metre bridge, 93
 Meyer, *G.*, 194
 Migration constant, 180
 — of ions, 179
 Millikan, *Prof. R. A.*, 486
 Minolta, *M.*, 456
 Molecular theory of magnetisation, 289
 Moseley, *H. G.*, 563
 Motion of Faraday tubes, 137, 414
 Motor, polyphase and single-phase, 375
 Moving charge and current, 527
 Muller, *H. W.*, 466
 Multiple arc, 63
 Mutual inductance, 313, 322, 330, 380

N

Napier's curve, 46
 Negative corpuscles, 469, 471
 Neon, 458
 Nernst, *W.*, 196, 557
 Nernst and *Eitenghausen* effect, 557
 Neutral temperature, 215

Nickel, 277, 287
Nicols, E. F., and *Hull, G. F.*, 420
Nippoldt, A., 40
 Normal electrode, 198

O

Oersted's experiments, 51
 Ohm, the, 62
 —, determination of the, 398
Ohm's law, 60
 Origin of radium, 520
 Oscillation, frequency of, 336
 —, stationary, 433
 — valve, 442
 Oscillators, Hertz, 436
 —, open and closed, 443
 Oscillatory charge, 334
 — discharge, 339, 423
 Oscillograph, 356
 Osmotic pressure, 178
Ostwald, W., 196

P

Parallel, condensers in, 153
 —, conductors in, 63
 — plate condenser, 150
 — wires, 434
 Paramagnetism, 544
 Partial conductivity, 184
Paschen, F., 198, 465, 535
Paschen's law, 465
Peltier, T. J., 202
Peltier coefficient, 205
 — effect, 204, 554
 Permeability bridge, 299
 —, magnetic, 233
 — measurement, 271, 273
 Permeameter, 299
Perrin, J., 469, 488
 Phases of elect. and mag. fields, 429
 Phosphorescence, 466
 Photo-electricity, 477
 Piezoelectricity, 224
 Plane charged conductor, 128
 — electromagnetic wave, 411, 415
 — of polarisation, 416, 437
 — sheet, field near, 127
Planté cell, 200
 Platinum resistance thermometer, 97
Poggendorf, comparison of E.M.F.'s, 103
Poincaré, H., 136
Poisson's equation, 407
 Polarisation, 174
 —, plane of, 416, 437
 Poles in contact, 283
 —, terrestrial magnetic, 36
 Polonium, 500

Polyphase motor, 375
 Positive rays, 563
 Post office box, 92
 Potential, 12, 120
 — difference, 58
 — due to charge, 112
 — due to magnetic shell, 226
 Potentiometer, 103
 —, *Crompton*, 107
 —, zero error of, 104
Poulsen arc, 445
 Power, 61
 —, alternating current, 349
 — factor, 351
 —, thermo-electric, 209
Poynting's theorem, 417
 Practical units, 61, 308, 395
 — unit of capacity, 312
 — — of inductance, 308
 — standards, 397
 Pressure due to wave, 420
 —, solution, 195
Price, W. A., 91
 Prismatic compass, 20
 Pyro-electricity, 223

Q

Quadrant electrometer, 157, 499
 Quadrantal deviation, 47, 49

R

Radiation from canal rays, 489
 — (*Heitz*), 435
 — from Oscillator, 427
 Radioactive changes, 508
 — constant, 511
 — substances, table of, 522
 Radioactivity, atmospheric, 521
 —, excited, 513
 Radio-balance, 222
 Radiometer effect, 421
 Radio-micrometer, 221
 Radium, 500, 514
 — emanation, 514
 —, emission of heat by, 515
 —, life of, 519
 —, origin of, 520
Ramsay, Sir W., 515
 Range of a rays, 503
 Rate of discharge, 340
 Rational current element, 52
Rayleigh, Lord, 68, 106, 190, 288, 321,
 323, 397, 400, 403
Rays, Becquerel, 497
 —, canal, 488

Rays, kathode, 468
 Reactance, 436
 Recalescence, 286
 Recording magnetographs, 41
 Rectifying valves, 440, 442, 493
 Reflecting magnetometer, 8
 Reflection of plane wave, 430, 536
 Refraction of light, 421
 — and dispersion, 537,
 — of waves, 437
 Refractive index, 421, 536
 Relation between units, 390
 Repulsion, electromagnetic, 369
 Residual magnetism, 276
 Resistance boxes, 89
 — by damping, 258
 —, electrical, 60
 —, high frequency, 364
 —, magnetic, 293
 —, measurement of, 90
 — of cell, 99, 105
 — of network, 73
 — of spark gap, 447, 464
 Resistivity, 63
 —, table of, 64
 Reversible cells, 187
Richardson, O. W., 563
Rieke, E., 549
 Right-hand rule, 249
Rimington, E. C., 327
Röntgen rays, 469, 528
 — —, secondary, 471
 Rotating magnetic field, 370
 — vector, 377
Rowland, H. A., 410
Runge, C., 535
Rutherford, Prof. E., 442, 446, 478,
 482, 500, 501, 502, 509, 512, 513, 516,
 517, 519, 523

S

Sagnac, G., 471
Sarasin, 438
 Saturation current, 479
Savart, Biot and, 52
Schmidt, G., 500
Schuster, Prof. A., 39
 Secohmmeter, 325
 Secondary cell, 200
 — *Röntgen* rays, 471
 Secular variation, 38
Seebeck effect, 203
 Self-inductance, 302, 324
 Semicircular deviation, 47, 50
 Sensitiveness of galvanometer, 81
 — of *Wheatstone's* bridge, 72
 Series, condensers in, 153

Series, conductors in, 62
 Shell, magnetic, 52, 225
 Shielding, electromagnetic, 367
 —, magnetic, 235
 Ship's iron, 45
 Shunts, 84
 —, universal, 85
Sidgwick, Mrs., 397, 403
Siemens' electro-dynamometer, 246
Slow, P., 168
 Silver, electro-chemical equivalent of, 404
 — voltameter, 68
 Sine method, 31
 Singing arc, 444
 Single-phase motor, 375
 Skin effect, 365, 420
 Sliding condenser, 155
Smith, P. E., 404
Soddy, F., 509, 512, 515, 520
 Soft-iron ammeters, 88
 "Soft" X-rays, 470
 Solenoid, inductance of, 307
 Solenoidal current, 228, 232
Soleri, E., 455
 Solution pressure, 195
 Spark discharge, 464
 — potential, 464
 Specific inductive capacity, 119
 — resistance, 63
 Sphere, capacity of, 149
 — (electrical image), 146
 —, field near, 127
 — in electric field, 142
 — in magnetic field, 234
 —, mass of charged, 525
 Spinterometer, 404
 Spinthariscopes, 502
 Standard cells, 189
 — condensers, 152
 — inductance, 309, 315
 — magnetic flux, 262
Stark, J., 489
 Stationary oscillations, 438, 456
 Steel, iron and, 277
Steel, B. D., 183
Steinmetz law, 282
Stokes, Sir George, 470, 486, 528
 Storms, magnetic, 40
 Straight current, 231
 Stresses in Faraday tubes, 133
 Strong magnetic fields, 285
Strutt, Hon. J. W., 321
Stutt, Hon. R. J., 506, 517
 Sum and difference method, 103
Sumpner, W. E., 303, 341
 Sun-spot period, 40
 Susceptibility, magnetic, 267

Suspended coil, 240
 — — galvanometer, 78

T

Tait, Prof., 209, 218
 Tangent galvanometer, 54
 Telegraphy, wireless, 439
 Telephone currents, 455
 Temperature and dielectric constant, 170
 — and magnetisation, 286
 Terrestrial magnetism, theory of, 36
 Thermal conductivity, 552
 — detector, 441
 — E.M.F.'s, law of addition of, 205
 Thermions, 563
 Thermodynamics (cells), 187
 — (thermo-electricity), 206, 211
 Thermo-electric diagram, 210, 213, 218
 — power, 209
 — measurements, 219
 Thermo-galvanometer, 80
 Thermo-milliammeter, 221
 Thermometer, platinum resistance, 97
 Thermopile, 221
Thomson co-efficient, 208, 556
Thomson, Sir J. J., 411, 461, 473, 475, 478, 482, 484, 492, 507, 524, 527, 528, 555
 Thorium, 500
 — emanation, 512
 — X, 508
 Three-electrode valve, 493
 Time constant, 305
 — lag in magnetisation, 284
Tissot, C., 441
 Torsion balance, 116
Townsend, Prof. J. S., 490
 Transformer, 358
 — diagram, 361
 Transport ratio, 180
Trouton, Prof. F. T., 429, 436
 Tubes, Faraday, of induction, 129, 234
 — —, motion of, 137, 414
 — —, stresses in, 133

U

Ultra-violet light, 475
 Uncharged body, force on, 139
 — sphere in electric field, 142
 Unit charge, 117
 — current, 53, 225
 — pole, 3
 Units, 382
 —, electrical, 385

Units, electromagnetic, 386
 —, electrostatic, 386
 —, practical, 61, 308, 395
 Universal radiation, 523
 — shunt, 84
 Uranium, 497
 — X, 508

V

Valve, oscillation, 442
Van 't Hoff, J. H., 178
 Variation of the compass, 20, 44
 — in magnetic elements, 41
 Variometer, horizontal, 42
 Vector diagram, 345
 —, rotating, 377
 Velocity of ions, 182
 — of α rays, 503
 — of β rays, 505
 — of cathode rays, 473
 — of light, 391, 421, 530
Verdet's constant, 544
 Vertical intensity magnetograph, 43
 Vibrating magnet, 21
 Vibration galvanometer, 380
Vallari, E., 287
 Virtual current and E.M.F., 348
 Volt, 61
 — box, 108
 Voltmeter, 66
 Voltmeter, 86
 —, electrostatic, 161

W

Water voltmeter, 66
Watson, W., 42, 43
 Watt, the, 61
 — balance, 245
 Wattless current, 350, 354
 Wattmeters, 351
 Wave, energy of, 416
 —, plane, 411

Wave, pressure due to, 420
 Waves in parallel wires, 434
 — in wires and cables, 449
 Weak magnetic fields, 283
Weber's theory of magnetisation, 266, 289, 545
Wehnelt interrupter, 445
 — cathode, 469
Weiss, P., 548
Weston cell, 190
Wheatstone's net, 70
 — bridge, 92
Whetham, W. C. D., 183
Whiddington, R., 561
Wiedemann and Franz's law, 552
Wien, W., 488
Wilson, Prof. H. A., 495
Wilson, C. T. R., 482, 484, 486, 491, 498, 521, 523
Wimshurst machine, 114
 Wireless telegraphy, 439
Wood, Prof. R. W., 542
Wulf, T., 195

X

X-rays, 469
 —, characteristic, 561
 —, "hard" and "soft," 470
 —, interference of, 562
 —, reflection of, 562
 —, secondary, 471

Y

Yoke, bar and, 296
 —, double bar and, 297

Z

Zahn, H., 558
Zeeman effect, 532
 Zero error of potentiometer, 104

THE END

