

**THE BOOK WAS
DRENCHED**

UNIVERSAL
LIBRARY

OU_162321

UNIVERSAL
LIBRARY

-28-4-81--10,000

SMANIA UNIVERSITY LIBRARY

538
L214

Accession No. 4493

Notes on Magnetism.

should be returned on or before the date last marked below

NOTES
ON
MAGNETISM

CAMBRIDGE UNIVERSITY PRESS

C F CLAY, MANAGER

LONDON : FETTER LANE, E.C. 4

**LONDON : H. K. LEWIS AND CO., LTD.,
136 GOWER STREET, W.C. 1**

**LONDON : WILLIAM WESLEY AND SON,
28 ESSEX STREET, STRAND, W.C. 2**

NEW YORK : G. P. PUTNAM'S SONS

**BOMBAY
CALCUTTA }
MADRAS } MACMILLAN AND CO., LTD**

TORONTO : J. M. DENT AND SONS, LTD.

TOKYO : MARUZEN-KABUSHIKI-KAISHA

ALL RIGHTS RESERVED

NOTES
ON
MAGNETISM
FOR THE USE OF STUDENTS
OF ELECTRICAL ENGINEERING

BY

C. G. LAMB, M.A.

LECTURER ON ELECTRICAL ENGINEERING
IN THE UNIVERSITY OF CAMBRIDGE

CAMBRIDGE
AT THE UNIVERSITY PRESS
1919

PREFACE

THESE notes were drawn up for the use of students in the Engineering Laboratory, Cambridge. They contain an outline of such portions of magnetic theory as are required by a student in order to read the ordinary technical textbooks with intelligence. The scope is thus very limited, as only such essential parts of the subject are dealt with, but an attempt has been made to present the selected portions in some logical sequence.

The thanks of the author are due to the following: to Messrs Sankey and Sons, Messrs Elliott Bros, and Dr G. F. C. Searle for permission to use certain figures; to Mr J. B. Peace, Fellow of Emmanuel College, and Mr J. W. Landon, Fellow of Clare College, for many valuable suggestions as to the mode of presenting the subject, and for the help they have given in the reading of the proofs.

C. G. L.

9 September 1919.

WORKS OF REFERENCE

The following books and papers may be consulted with advantage :

- (1) *Induction in Iron and other magnetic metals.* Sir J. A. Ewing.
- (2) Iron Alloys. Barratt, Brown and Hadfield. *Journ. I. E. E.* Vol. 31. p. 674.
- (3) Cyclic Tests. Beattie. *Electrician.* 1909, July 23.
- (4) Magnetic Testing with Alternating Currents. Campbell. *Journ. I. E. E.* 1905. p. 55.
- (5) Magnetic Testing of Bars. Campbell and Dye. *Journ. I. E. E.* 1916. p. 35.
- (6) Saturation Value of the Induction. Hadfield and Hopkinson. *Proc. I. C. E.* 1910.
- (7) Hydrodynamic Analogies to Flux Distribution. Hele-Shaw, Hay and Powell. *Journ. I. E. E.* 1905. p. 21.
- (8) Instrument for measuring the Permeability of Iron. Lamb and Walker. *Journ. I. E. E.* May, 1901.
- (9) Testing of Transformer Steel. Lloyd and Fisher. *Bureau of Standards, Washington.* Vol. 5. No. 4. 1909.
- (10) Dependence of Wave-form on Hysteresis. Lloyd. *Bureau of Standards, Washington.* Vol. 5. No. 3. 1908.
- (11) Constant rate of change of Flux Tests. Morris and Langford. *Proc. Phys. Soc.* xxiii. 1911. p. 277.
- (12) Magnetisation of Iron at high inductions. Nicholson. *Journ. I. E. E.* 1915. p. 248.
- (13) Effects of Heating on Iron. Roget. *Proc. Roy. Soc.* Vols. 63 and 64.
- (14) Notes on a Vibration Magnetometer and the Ball-ended Magnets of Robison. Searle. *Cam. Phil. Soc.* Vol. 12. part 1.
- (15) Studies in Magnetic testing. Searle. *Journ. I. E. E.* 1905. p. 55.
- (16) Measurement of Magnetic Hysteresis. Searle and Bedford. *Trans. Roy. Soc.* 1902. p. 33.

CONTENTS

	PAGE
1. MAGNET	1
2. LAW OF FORCE	1
3. MAGNETIC FIELD AND FORCE	3
4. THE EARTH'S MAGNETIC FORCE	4
5. COMBINATION OF MAGNETIC FORCES	4
6. SPECIAL CASES OF COMBINED MAGNETIC FORCES	5
7. MAGNETIC MOMENT	5
8. OSCILLATION OF A MAGNET	7
9. FORMS OF MAGNETIC FIELD	8
10. POTENTIAL	10
11. EQUIPOTENTIAL LINES	10
12. CURRENTS AND MAGNETIC FIELDS	11
13. CIRCULAR COIL	13
14. TANGENT GALVANOMETER	14
15. A LONG WIRE	15
16. THE SOLENOID	16
17. MECHANICAL FORCE BETWEEN COILS	17
18. THE MOVING COIL GALVANOMETER	18
19. BALLISTIC USE OF GALVANOMETER	20
20. THE MAGNETIC DISPLACEMENT	22
21. THE INDUCTION	23
22. LINES OF FORCE	24
23. THE INDUCED E.M.F.	24
24. MAGNETIC POTENTIAL OF A COIL	26
25. EXAMPLES OF INDUCED E.M.F.'s	28
26. THE E.M.F. OF A DYNAMO	30
27. DAMPING OF A GALVANOMETER	34
28. FLUX MEASUREMENT	36
29. THE STANDARD FIELD	36
30. MAGNETIC BODIES	37
31. TYPICAL CURVES	38
32. PERMEABILITY	40
33. DERIVED UNITS OF FLUX AND MAGNETIC FORCE	41
34. FORMS OF SPECIMEN	42

	PAGE
35. FORMS OF THE B — H CURVES	42
36. HIGH INDUCTIONS	43
37. EFFECTS OF TEMPERATURE, ETC.	45
38. THE CYCLIC CURVE	46
39. THE LOST ENERGY	51
40. FORCE BETWEEN TWO SURFACES	52
41. PRACTICAL DETERMINATION OF CYCLE	53
42. EFFECT OF COMPOSITION, ETC.	55
43. MAGNETIC HISTORY, LOOPS	55
44. MAGNETIC TESTER	57
45. ROTATING HYSTERESIS	58
46. EDDY CURRENTS	60
47. EFFECT OF SUBDIVISION	62
48. THE INDUCED VOLTAGE METHOD	63
49. THE MAGNETIC CIRCUIT	66
50. MEASUREMENT OF DIFFERENCE OF MAGNETIC POTENTIAL	67
51. PERFECT CIRCUIT	69
52. POSITION OF COIL	70
53. A CUT RING	70
54. SELF-DEMAGNETISING FORCE	71
55. THE DOUBLE YOKE METHOD	71
56. THE MAGNETIC BRIDGE	72
57. STRAY FLUX	73
58. REFRACTION OF THE FLUX	74
59. DISPERSION COEFFICIENT	75
60. EQUALISING EFFECT OF LEAKAGE	76
61. THE INTENSITY OF MAGNETISATION	77
62. EWING'S MOLECULAR THEORY	78
63. TESTS WITH ALTERNATING CURRENTS	80
64. TESTING STRIP SPECIMENS	84
65. FURTHER CONSIDERATION OF EDDY LOSS	85
66. THE FORM FACTOR	85
67. VERIFICATION OF THE LAW	87
68. INSTANTANEOUS CURVE METHOD	87
69. THE CYCLE AS AFFECTED BY EDDIES	89
70. EFFECT OF A LOOP	90

MAGNETISM

1. **Magnet.** A magnet is a piece of iron or steel which is endowed with special properties such as attracting to itself other pieces of iron. It is usually in the form of a straight or bent bar of circular or rectangular section, and it may be either a Permanent Magnet with inherent properties of attraction, or an Electro-magnet which acquires these properties when it is wound with a wire carrying an electric current. On dipping such a bar into fine iron filings, we find that the filings adhere to the end portions of the bar, known as its Poles, and there form a layer of somewhat irregular thickness and outline. A more definite arrangement is given by modifying the magnet as follows: let the ends be made of two small spheres such as bicycle balls, and connect these by screwing the balls on to the ends of a knitting needle. We then have a ball-ended magnet, and if this be dipped in the filings it will be seen that they adhere practically only to the spherical ends and in a layer of nearly uniform thickness, so that we may assume the property is confined to two quite definite ends or poles.

2. **Law of Force.** If a straight ball-ended magnet be freely suspended so that it can move about a vertical axis, it will be found that it comes to rest with the line joining its poles pointing in a direction nearly coincident with the geographical north and south. We can thus give names to the poles; that pointing to the north is called the North (seeking) or N pole, the other being the South (seeking) or S pole. Let the poles be suitably marked, both in the suspended magnet and in a second one. Then bring the poles of the latter in turn near those of the suspended one. It will be found that similarly marked poles mutually repel and dissimilarly marked poles mutually attract; that is, the property of attraction is possessed by the poles in exactly opposite ways. If a series of different magnets be used successively to act on the suspended one, it will be further found that some act with much more vigour or "strength" than others, hence we can say that magnets differ in respect to the strengths of their poles; also it will be found that the distance between the poles has a great effect. It is therefore necessary to investigate both these points, and this is done with

the apparatus shown diagrammatically in Fig. 1. This apparatus is due to Dr G. F. C. Scarle.

To avoid complications it is desirable to restrict the action to that of one single pole on another. This is secured by hanging the suspended magnet by means of a fine wire passing through one of its poles and counterpoising its weight by a balance weight C . The other magnet is placed as shown, so that the upper pole is vertically above the free pole of the suspended magnet, and thus the whole action is restricted to that between a single pole of each magnet. If the fixed magnet be placed in position as shown, care being taken that repulsive action is produced, the suspended magnet will swing away, and it can be brought back by twisting the wire suspension through a measured angle by means of a torsion head T . The positions of the poles are read on a scale by means of short threads fixed to the poles and carrying small weights.

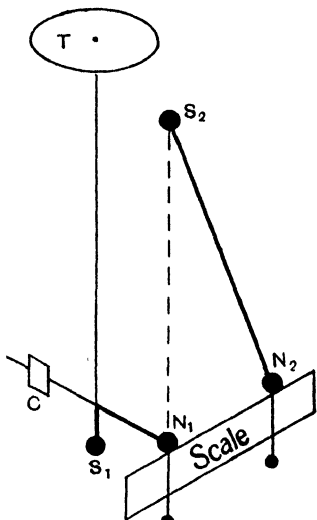

Fig. 1

By means of this apparatus we can investigate the relation of the force between the poles to their distance apart: the force is proportional to the twist given to the torsion head, the distance is the distance between the threads. It will be found that the force is inversely proportional to the square of the distance. If the dimensions and elastic properties of the wire be known, we can at once evaluate the force in any desired units; the unit of force usually employed is the Dyne or c.g.s. unit. Hence if f be the force in dynes and r the distance in cm. we have $f \propto 1/r^2$.

If, with the same suspended magnet, a series of magnets be placed successively in the "fixed" position it is found that with a constant distance the force produced is different for each. This result is expressed by saying that the magnets differ in Pole Strength. Let the Pole Strength be denoted by m_1 for the fixed magnet. Since the relation is reciprocal, we may also specify the corresponding property of the suspended magnet by the letter m_2 . It follows that if f is the force between two poles we can write

$f \propto \frac{m_1 m_2}{r^2}$. It will also be found that it is a matter of indifference

whether we measure the repulsion between the N poles or that between the S poles, the force is the same when the distance is the same. From this it follows that the poles of a magnet have the same strength. It only remains to choose a suitable unit in which the pole strength is to be measured, and we can then replace the sign of proportionality by one of equality.

In order that this result may be attained we must evidently consider the unit pole strength to be that possessed by each of two equal poles if the force between them be one dyne when the distance is one centimeter. If we select this unit we can then write

$$f = m_1 m_2 / r^2.$$

3. Magnetic Field and Force. A Magnetic Field is merely that space where a magnetic pole will experience mechanical force in virtue of the presence of other magnets or their equivalents. In other words, the space surrounding a magnet becomes endowed with some new property in virtue of which a magnetic pole placed therein experiences mechanical force. The physical property which the field possesses is known as the strength of the field or the Magnetic Force, the latter an unfortunate and misleading term, but one too well established to be now dislodged. We can thus concentrate our attention on any point in the field, and if a magnetic pole be placed at that point, the resulting mechanical force it experiences can be considered to be due to the conjoint presence of the magnetic force and the pole. As an example consider the case of two simple poles; we have seen that the expression for the mechanical force between them can be written $f = m_1 m_2 / r^2$. This method of expressing the result necessitates us having in mind both the poles and the space between. Now write the expression in the form $f = m_1 (m_2 / r^2)$ and use a single letter H for the bracket. The force is now expressed by $f = m_1 H$. We have now only to consider the pole of strength m_1 and the quantity H at the same point. In fact the latter is the "magnetic force" existent at the point, which in this special case is due to the other pole. Thus the magnetic force due to a pole m_2 at a point distant r from it is $H = m_2 / r^2$. The unit magnetic force is that existing at unit distance from a unit pole; it has received the name of a Gauss. The positive direction of magnetic force is taken to be that in which a N pole

is urged. The concept of a magnetic field and of magnetic force is more general than the expression for the force between two poles, and we can at once extend it to another important case.

4. The earth's magnetic force. One of the fundamental properties of a magnet was, as we saw, that it takes up a definite orientation pointing nearly north and south. This means that the poles of the magnet are subjected to magnetic force, in other words that the space surrounding the earth constitutes a magnetic field. If the magnet is pivoted about its centre of gravity and carefully balanced in a horizontal position before it is made magnetic, it will be found that when magnetised, it not only takes up a position pointing nearly in the north and south direction, but also dips down at a definite angle to the horizontal plane. The angle made with the true geographical north and south line is called the Declination, that made with the horizontal is called the Dip. Suspension in this perfectly free manner is most frequently both unnecessary and inconvenient, and the magnet is usually constrained to move in a horizontal plane only, being placed on a vertical pivot, which does not pass exactly through its centre of gravity. A small magnet pivoted in this manner is familiarly known as a compass and the magnet is called the needle. Suppose that we place such a compass on a little raft and float it on water. It will be seen that no translational motion takes place, the only movement being one of rotation. This shows at once that the mechanical action is a couple, and that the forces on the poles are exactly equal and opposite. But since the poles have the same strength, it follows that the magnetic force must be the same at each pole, or that the magnetic force is uniform in value in the space where the compass is placed. Such a space is called a uniform magnetic field. Thus, in addition to any field that may be present due to the action of a magnet, we may have also this new field due to the earth's magnetic force.

5. Combination of magnetic forces. The pole strength of a magnet is a directionless or scalar quantity. When placed in a magnetic field the pole experiences a mechanical force according to the law $f = mH$. It follows that since the mechanical force is a directed or Vector quantity, the magnetic force is likewise a Vector quantity, and that magnetic forces can therefore be added

to the product ml . This product is called the **Magnetic Moment** of the magnet.

Let a magnet whose length between the poles is $2l$ cm. be placed on a table so that the line joining its poles lies in the east and west line (see Fig. 3). Consider a point P on this line distant r cm. from the mid-point of the magnet. Since the poles have the strengths m and $-m$ and are distant from P $(r-l)$ and $(r+l)$ cm. respectively, the corresponding magnetic forces there are $m/(r-l)^2$ and $-m/(r+l)^2$, acting in the east and west line, and hence the resultant magnetic force at P due to the magnet is

$$m \left(\frac{1}{(r-l)^2} - \frac{1}{(r+l)^2} \right) \text{ or } \frac{4mlr}{(r^2 - l^2)^2}$$

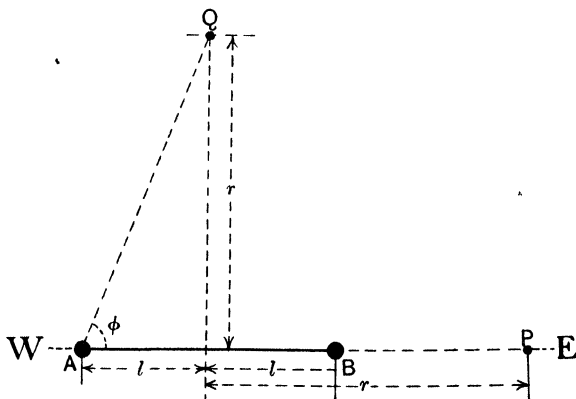

Fig. 3

If a magnetometer be placed at P it will deflect through an angle θ , and since the earth's field and that due to the magnet are there at right angles, we at once have $\frac{4mlr}{(r^2 - l^2)^2} = H_e \tan \theta$, or if M denote the magnetic moment of the magnet, M being $2ml$, we have

$$M = \frac{(r^2 - l^2)^2}{2r} H_e \tan \theta.$$

This relative position of the magnet and magnetometer is called the *end-on* position.

It is evident from symmetry that at any point Q , on the north and south line which bisects the magnet at right angles, the magnetic force due to the magnet is again perpendicular to the earth's

magnetic force. When the magnetometer is placed at such a point it is said to be in the *broadside* position. The magnetic forces at Q are equal to $\pm m/(r^2 + l^2)$ and act along QA and QB respectively, the one towards A the other away from B , hence the north and south components balance, and the resultant force is the sum of the east and west components. Noting that $\cos \phi = l/(r^2 + l^2)^{\frac{1}{2}}$, we find that the value of the magnetic force at Q is $2ml/(r^2 + l^2)^{\frac{3}{2}}$. Therefore if θ be the deflection of a magnetometer at Q we have

$$M = (r^2 + l^2)^{\frac{3}{2}} H_e \tan \theta.$$

It may be noted that when the distance r is large in comparison with l , these expressions reduce to $M = \frac{r^3}{2} H_e \tan \theta$ for the end-on position and $M = r^3 H_e \tan \theta$ for the broadside position, so that if we place a magnetometer at the same distance from the mid-point of the magnet, first in the broadside position and then in the end-on position, and if the corresponding deflections be θ_1 and θ_2 , we should find that $\tan \theta_2 = 2 \tan \theta_1$. Experimental verification of this gives a confirmation of the inverse square law, since the formulae are directly derived from it.

8. Oscillation of a magnet. There is another method by which a comparison of two magnetic forces can be made. If a body be suspended about an axis in such a manner that the couple tending to bring it back to its position of rest is proportional to the angle through which it is turned, it will oscillate about its position of rest with a definite period of oscillation. Further, if the restoring couple be proportional to the angle by which the body is displaced, and be equal to $L\theta$ where the angle of displacement is θ radians, and if the moment of inertia of the body about the axis of rotation be K , the time, T , of a complete to-and-from oscillation, is given by $T = 2\pi\sqrt{\frac{K}{L}}$ provided the units are consistent. If the suspended body be a magnet whose magnetic moment is M , hung by a fine thread of small torsional control, and if the magnetic force of the field in which it is placed be H , we have seen that the couple acting when the angle of deflection is θ is $MH \sin \theta$. Now if that angle be always small enough, we can write this as $MH\theta$ so that, in this case, $L = MH$. Hence a magnet

suspended thus and executing small oscillations will have a periodic time $T = 2\pi \sqrt{\frac{K}{MH}}$ seconds.

An interesting deduction is made by connecting this result with that just obtained, for it will be noticed that if the same magnet be first used to cause deflection, and be then suspended and its periodic time taken, the first experiment gives the ratio of the quantities M and H while the latter gives the product, hence the two quantities can be found separately. In this way the value of the earth's magnetic force at any point can be found. But it further follows that if the magnet be successively swung in two fields whose magnetic forces are H_1 and H_2 and if T_1 and T_2 be the corresponding periodic times, $H_1/H_2 = T_2^2/T_1^2$, or if n_1 and n_2 be the number of complete swings in any given time, $n_1^2/n_2^2 = H_1/H_2$; thus we have a very simple method of comparing the magnetic forces at two points. In order that we may be certain that the field is at least approximately uniform it is desirable that the swinging magnet be small. It is also desirable that it should swing slowly; this is secured by fixing a little magnet to a brass cylinder, and suspending the whole by a fine thread; a magnet mounted in this way is called a Vibration Magnetometer.

9. Forms of magnetic field. By the form of a magnetic field is meant a diagram showing the direction in which the magnetic force acts at every point. The form in any plane can be found as follows. Let a small compass be mounted on a metal base in which are pierced two small holes exactly in line with the pivot, and join the holes by a line drawn on the base. Place the compass on a table, covered by a sheet of paper, anywhere in the magnetic field, and put a pin through one hole, which we shall call A . Rotate the base till the needle lies along the marked line and put a second pin through the other hole, B . The line joining the holes can be drawn on the paper and gives the direction of the magnetic force in the plane of the table. Now remove A and turn the compass about B till the needle once more lies along the marked line, insert a pin in the free hole, and we have a third point of the diagram. By continuing in this way, and starting at different points, a complete mapping-out of the direction of the magnetic force in the plane is obtained. Fig. 4 gives such a diagram for a single magnet, and Fig. 5 the same for two magnets. Such points as that marked P ,

round which the lines sweep, are called **Neutral Points**, since at them there is no magnetic force. It will be seen that the lines thus

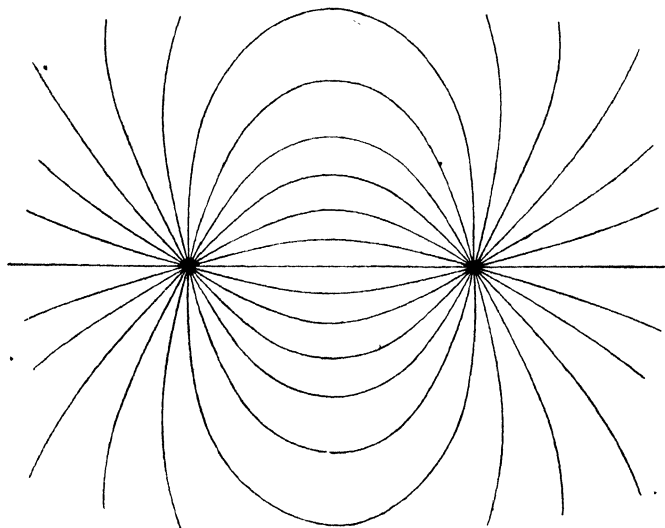

Fig. 4

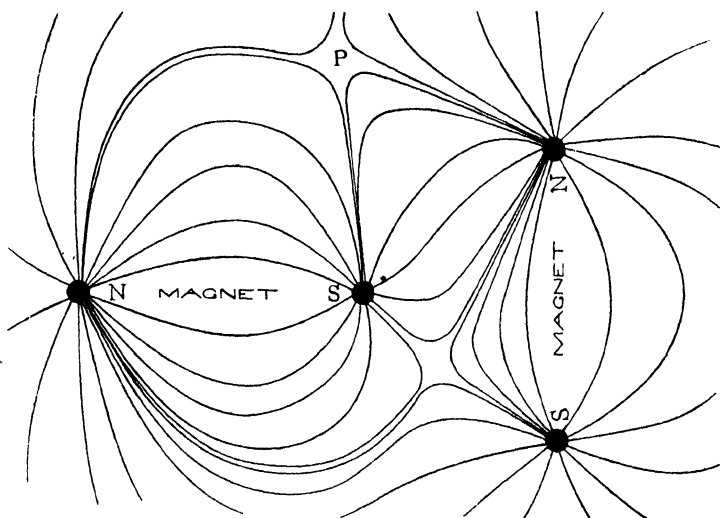

Fig. 5

traced always begin and end on the poles of the magnets. The lines are often called **Lines of Force**, but as this term has a special

quantitative meaning, it is better to avoid its use in this connection. It will be at once evident that for a uniform field there will be a set of parallel straight lines, while for a single isolated pole the lines will be radial.

10. Potential. A quantity which greatly simplifies the calculation of the magnetic force in some cases is that known as the Potential. It is defined as the work that has to be done in bringing a unit pole from an infinitely great distance up to the point at which the potential is required. In the case of an isolated pole it can be readily calculated. Let a unit pole be distant r cm. from a pole of strength m , then there will be a mechanical force of the amount m/r^2 acting on it, and if it moves a distance dr towards the pole, the work done on or by it will evidently be $m dr/r^2$. Hence to bring the unit pole up from an infinitely great distance to the point under consideration, the work done will be $\int_r^\infty m dr/r^2$ or m/r . Further since no work can be done when the motion is at right angles to the force acting, and since any path can be made up of tiny rectangular steps in the direction of the force and at right angles thereto, the value of the potential is independent of the path from infinity. Yet another deduction is this; if the potential at a point A is V_1 and at any other point B is V_2 , the work done in moving the unit pole from A to B is $V_1 - V_2$ and is independent of the path. Again, if we move the unit pole in a direction other than that in which it naturally tends to move, say from a point where the potential is V_1 to a near point where it is V_2 , the two differing by the small amount dV , the work done will be given both by dV and by $f dr$ where f is the force in the arbitrarily selected direction, hence $f = dV/dr$ always.

11. Equipotential Lines. From what we have just seen, it appears that in any plane field we can draw a set of lines characterised by the property that no force acts along them, so that for each of them the potential has a constant value. These lines are called Equipotential Lines, and they must everywhere cut the former lines at right angles. They can readily be traced as follows: if the little compass have fixed to it a light cross bar of brass placed accurately at right angles to the compass needle, a line of constant potential can be traced exactly as the former lines were, if the

successive adjustments are made with reference to the brass bar instead of to the needle. For each line there will exist a definite value of the potential which can readily be found for any point on any line when the pole strengths of the magnets are given, hence we can in this way give a quantitative view of the whole field of magnetic force.

12. Currents and Magnetic Fields. Let us take a small coil of wire, fix it to a cork float with its plane vertical, attach to the cork two plates, one of zinc the other of copper, solder one end of the coil to the zinc and the other to the copper, and float the whole in a vessel containing dilute sulphuric acid, the plates dipping in the acid. The plates and acid thus form a battery, and a current will flow round the wire. The float will be seen to turn round till the axis of the coil points (like a magnet) in the north and south line, and the coil will behave to magnets brought near it exactly as if it were itself a magnet. We see, then, that a coil of wire carrying a current produces a magnetic field. Since the direction of flow of a current is arbitrarily taken to be from the copper to the zinc *viâ* the coil, we can find what is the relation between the direction of the current and that of the magnetic force it produces. If we stand in front of the coil and if the current direction on the face of the coil which is towards us is clockwise then we find that this face will attract a north pole and the other face will attract a south pole, that is to say the coil behaves as if the near face were a south pole and the further one a north pole, and produces a field of magnetic force just as a magnet does.

In order to investigate the laws governing this magnetic force, we must simplify the circuit. Suppose that we have a single very long wire hanging vertically with a current flowing *downwards* in it. If a compass be placed anywhere near it, the needle will always place itself at right angles to the horizontal line joining its middle point to the wire, that is to say the direction of the force is in the tangent to the circle which passes through the point and is concentric to the wire. Further the north pole tends to move in a direction which is clockwise or right-handed when looked at from above, that is when looked at in the direction in which the current is flowing.

Both in this and in the previous example the relative direction of translation and rotation can be referred to the case of an ordinary

corkscrew; if the corkscrew is advancing in the direction of the straight current its rotation is in the direction of the magnetic force, and if the corkscrew is rotating in the direction of the current in the coil its advance is in the direction of the magnetic force at any point on the axis of the coil.

We must now attempt to derive some general expression from which to find the magnetic force due to certain important standard forms of circuit, and in order to do so we will reduce the problem to its simplest elements. Let a very short wire of length dl carry a current I in the direction

shown by the arrow (Fig. 6), the unit of current being so far undetermined. The method by which the current enters and leaves this element of wire will not be considered. For simplicity we may assume that it enters and leaves perpendicularly to the length, as indicated, and that the currents in the entering and leaving conductors produce no effect. In all practical circuits that we shall deal with, the points of entry and exit of the current can be made nearly coincident, so that no effect will be produced. Further let a pole of strength m be placed at a point distance r cm. perpendicularly from the middle of the short wire. From what we have seen, a force will act on the pole driving it away from us in the direction shown in the plan. But there must of necessity be an equal reaction or force on the wire, as is also shown. We thus have a wire of length dl , carrying the current I , and placed in the magnetic field produced by m , the strength of the field or magnetic force due to that magnet being m/r^2 . The mechanical force df produced on the wire will depend on these three factors. The most simple assumption to make is that it is proportional to each severally, and therefore can be

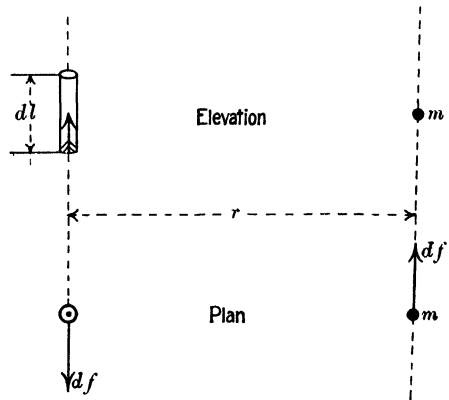

Fig. 6

written $df = \lambda I \frac{m}{r^2} dl$, λ being an arbitrary constant. Let us make this assumption, deduce from it certain results, and submit them

to experiment. If they be found true, we can suppose that our fundamental assumption accounts for the facts observed.

In general we want the force on the pole rather than that on the wire, but this is given by the same expression. Furthermore we must regard the force acting on the pole as being due to the fact that the pole of strength m is in a magnetic field at a point where the strength of the field is H . The value of the force must be mH and if the equation above be rearranged in the form

$$df = m \left(\frac{\lambda I dl}{r^2} \right),$$

we see at once that at the point considered the magnetic force due to the little piece of wire is $H = \lambda \frac{I dl}{r^2}$, the value of λ being dependent only on the unit of current employed, since the force is in dynes, and the magnetic pole in terms of the unit pole. Let us now deduce some results.

13. Circular coil. Let MN (Fig. 7) be the section of a circular coil of one turn carrying a current I , and let P be any point on its axis distant x from the centre and c from the circumference, the radius being r . Consider an element of length dl at M ; it will produce a magnetic force of the amount $\lambda I dl / c^2$ in the direction PA , at right angles to PM . But we are only concerned with the horizontal part of this, PD , since the vertical part is exactly balanced by the action of the opposite element at N . Hence the horizontal magnetic force along the axis is given by $\lambda I dl \sin \theta / c^2$. It will be seen at once that every element of the coil being at the same distance c from P , the total magnetic force due to the whole turn is

$$H = \lambda I 2\pi r \sin \theta / c^2.$$

This result is often written $\lambda \frac{2\pi I r^2}{c^3}$ or $\lambda \frac{2\pi I}{r} \sin^3 \theta$. If the point P be at the centre of the coil, this reduces to $\lambda \frac{2\pi I}{r}$. It

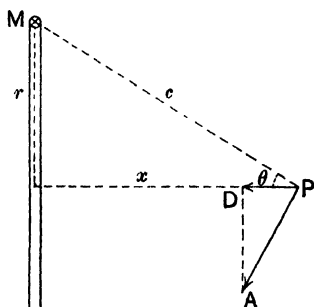

Fig. 7

will be manifest that a coil containing n turns all nearly coincident will produce n times the effect, so that the magnetic force due to such a coil is $\lambda \frac{2\pi In}{r} \sin^3 \theta$. We can now select our unit of current to simplify this relation, and it is usual to take λ as unity, so that the unit current flowing round a single circular coil of unit radius produces a magnetic force of 2π at the centre of the coil; this is called the Absolute unit of current. The ampère or practical unit of current is arbitrarily taken to be one-tenth of this unit. We will usually use the Absolute unit for convenience.

We will now subject this result to test. Take a circular wooden disc and turn in it two concentric grooves, making one exactly twice the radius of the other. Wind coils in the grooves the larger coil having twice as many turns as the smaller. Fix the disc in the vertical plane through the north and south line, and place at the centre a small compass provided with a pointer and scale. Let a current be sent down the two coils in series the coils being connected so that the current flows in opposite directions in the two. We find that the needle remains quite unaffected, that is the magnetic forces of the coils annul one another. But as the larger one has twice the turns and twice the radius, this shows that the magnetic force is inversely as the radius. If now the compass and scale are placed at successive points on the axis of the disc, at measured distances from the centre, and a single coil is used, it will be found that the tangent of the angle of deflection is inversely proportional to the cube of the distance from the circumference of the coil. From these results we then deduce a confirmation of our fundamental assumption.

14. Tangent galvanometer. The arrangement of a single large coil with a compass needle mounted at its centre is called a tangent galvanometer. For when the coil is placed in the vertical plane through the north and south line the magnetic forces of the earth and of the coil are at right angles, the latter being normal to the plane of the coil, and it follows, from what we saw on p. 5, that $\frac{2\pi In}{r} / H_e = \tan \theta$ or that $I = \left(\frac{rH_e}{2\pi n} \right) \tan \theta$. The factor in brackets is called the constant k of the galvanometer, so that $I = k \tan \theta$. A similar result will hold for any coil with a magnet suspended in or near it, but the current will no longer be expressed

by the definite function $\tan \theta$ of the angle, but by some other. If, however, the angle of deflection is small enough we can very approximately write $I = k\theta$. The details of such instruments can best be studied in the laboratory.

15. A long wire. An important case is that of the very long straight wire. Let XX , Fig. 8, be such a wire, and P a point distant r from it. Consider a short element dl at the point A distant l from O , O being the projection of P on the wire. Let $AP = \rho$. If that element, carrying the current I , had been perpendicular to the direction PA it would have produced at P a magnetic force $dH = Idl/\rho^2$. But it is inclined to that direction, and it is only the resolved part of its length perpendicular to AP that is effective, namely $dl \cos \theta$. Hence the element of magnetic force contributed by dl is $Idl \cos \theta/\rho^2$, and its direction is perpendicular to the plane of the figure. But we have $\rho = r \sec \theta$ and $l = r \tan \theta$, so that $dl = r \sec^2 \theta d\theta$ and hence $dH = I \cos \theta d\theta/r$. The whole magnetic force is due to the infinite wire, and the limits of θ for the ends are evidently $\frac{\pi}{2}$ and $-\frac{\pi}{2}$. Hence we have

$$H = \frac{I}{r} \int_{-\pi/2}^{\pi/2} \cos \theta d\theta$$

or $H = 2I/r$. Thus the magnetic field consists of circles concentric with the wire, and the magnetic force is inversely proportional to the distance from it.

Suppose we suspend a light disc concentric with the wire and able to turn freely about it, and then place a magnet in any position on the disc, we shall find that there is no tendency for the disc to turn. But the arms of the moments of the forces on the equal and opposite poles are their radial distances from the axis, and, since no motion ensues, the corresponding magnetic forces must be inversely as those distances. We thus have another indirect proof of our fundamental assumption.

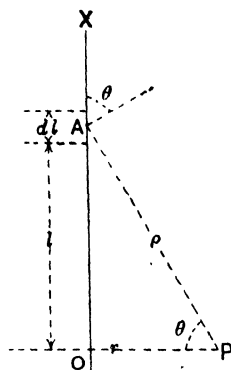

Fig. 8

16. The Solenoid. The most important form of coil is, however, the solenoid. This consists of a set of turns of exactly similar shape very closely wound about an axis. We will first take the case of circular coils with a straight axis, which can be very nearly realised by winding a close spiral of wire on a tube or cylinder of uniform radius as shown in section in Fig. 9. Let the radius of the coil be r cm., the current passing in it be I absolute units and P a point on its axis. Let the coil be so wound that there are N turns per cm. Consider a turn at the distance x from P , and let θ be the angle subtended at P by the radius of that turn. The magnetic force due to the single turn is $2\pi I \sin^3 \theta / r$. Now take a slice dx thick, which will have in it Ndx turns. The magnetic force at P due to this slice is $2\pi IN dx \sin^3 \theta / r$. To get the whole magnetic force we have only to add up the forces due to all the

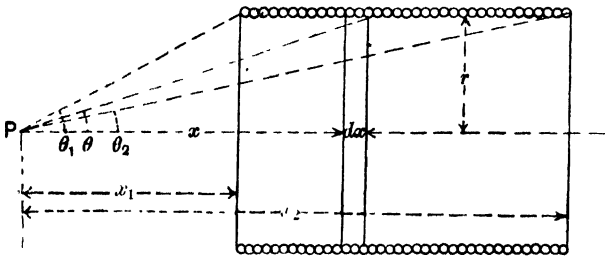

Fig. 9

slices from end to end. If the radii of the first and last turns subtend at P angles θ_1 and θ_2 respectively the value of the magnetic force at P due to the whole solenoid is then

$$H = \frac{2\pi IN}{r} \int_{x_1}^{x_2} \sin^3 \theta dx.$$

But $x/r = \cot \theta$, hence $dx = -r \operatorname{cosec}^2 \theta d\theta$. Thus

$$H = 2\pi IN \int_{\theta_2}^{\theta_1} \sin \theta d\theta,$$

which at once gives

$$H = 2\pi IN (\cos \theta_1 - \cos \theta_2).$$

Let the point P be inside the coil and midway between its ends, the magnetic force is then $H = 4\pi IN \cos \theta$ where θ is the angle subtended at P by the radius at either end. Finally, if the solenoid be very long we have at once $H = 4\pi IN$ as the value of the force at the middle point. This is a result of the greatest

importance for future work. Since the expression involving the ends has disappeared, the magnetic force is the same anywhere inside and is independent of the shape of the section of the solenoid.

17. Mechanical force between coils. Since a coil carrying a current produces a magnetic field, a second coil carrying another current and placed anywhere near the first will cause a mutual reaction between the two coils. Further if one be fixed and the other pivoted, this reaction will be reduced to a couple tending to rotate the second coil. If this be provided with some suitable controlling device, such as a spring, the second coil will turn until the rotating couple is balanced by the control. But since the magnetic action of either coil, at all points, is proportional to the current in it, the couple exerted by one coil on the other in any relative position, is proportional to the product of the currents, and if the coils are arranged so that the same current passes in each, the couple acting will be proportional to the square of the common current. Instruments in which the couple between a fixed and a moving coil is balanced by a spring control are said to be of the dynamometric type, and the readings of such an instrument can be calibrated by passing through it a series of known currents.

The necessity for calibration can be avoided, however, if the moving coil is always brought back to a given position, namely that corresponding to zero current, as may be done by twisting round the head of the controlling spring. The angles of twist can be read on a circular scale, and the current passing through the coils is proportional to the square root of this angle. This form of instrument is usually called a Dynamometer and is of the zero-reading type. Since the effect depends on the square of the current it is independent of its direction, and if the current is varying in a regular periodic manner between definite positive and negative maxima, the couple will always be in the same direction and proportional to the square of the instantaneous value of the current. Hence the mean value of the couple will be proportional to the mean of the square of the current; further if the time of one complete period of change is not too long, the inertia of the coil will average out the variations of the couple, and the indication of the instrument will actually give the mean square of the varying current with respect to time. The root of that mean square is called the Virtual current and is the appropriate concept of

“current” when it is alternating as described above. It should be noted that the constant of the instrument is the same with both steady and alternating currents, a fact of much importance since we can first calibrate it with a high degree of accuracy by means of direct current, and then be sure that it will measure correctly the “virtual current” in the case of alternating currents. When a dynamometer is used to measure the current in any circuit the dynamometer coils may, if desired, be shunted in any constant manner, as each coil will then carry a definite fraction of the current in the circuit and the readings of the instrument will remain proportional to the square of the current.

Another very important measurement in connection with an electric circuit is the power. If the fixed coil of an instrument of the type described carries the current in the circuit to be measured, and the other is made to carry a current always exactly proportional to the pressure on that circuit, it is clear that the instrument will indicate the desired product. But this condition can be readily secured in the ordinary manner by placing in circuit with the second coil a very high resistance and connecting the terminals of the circuit thus formed to the ends of the circuit under test. An instrument arranged thus is called a *Wattmeter*. Like the dynamometer it has the valuable property that it indicates the mean value of the power when the current and pressure alternate in a periodic manner, provided the current in the shunting or pressure circuit is at every instant exactly proportional to the terminal pressure. If the circuit concerned has no property except pure resistance, there is nothing to call into existence any other pressure than that demanded by that resistance. Hence if the precaution is taken to ensure that the shunting circuit has resistance only, so that at each instant its current is exactly proportional to the pressure acting on it, the instrument will indicate power equally well for either direct or alternating currents. These points will be required later on.

18. The Moving coil galvanometer. It is very useful to be able to measure currents by an instrument in which the indication is directly proportional to the current. Suppose we have a magnetised rectangular bar bent into a ring with the ends forming parallel planes separated by a small gap and let a wire carrying a current be placed in this gap, parallel to the plane ends, or

polar faces of the bar. In Fig. 10 is shown such a wire together with one of the polar faces, the other being close over it. Since the poles are everywhere equidistant, the magnetic field in the space between them must be uniform except in the neighbourhood of the side boundaries. From what we have seen, the direction of the force acting on the wire will be related to the polarity of the magnet and the direction of the current as is shown in the figure. When a definite current is flowing the force on the wire will be the same so long as it is kept in the region of uniform field and is held parallel to the direction shown in the figure; the force will depend solely on

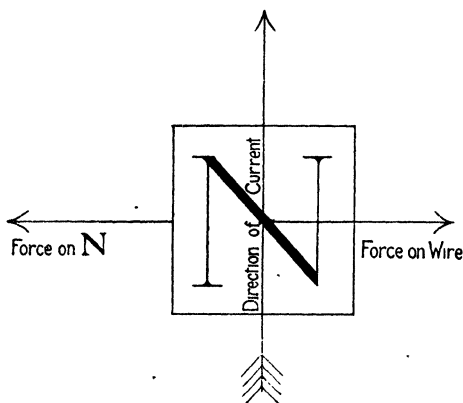

Fig. 10

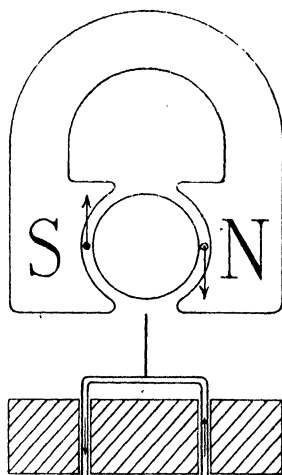

Fig. 11

the value of the current. Such an arrangement could be used to measure currents by means of the force on the wire, but it is inconvenient in mechanical form as rotation about an axis is better than translation. Let us modify the magnet in the form shown in Fig. 11. Again we see that the magnetic force in the annular space between the circular poles and the central cylinder must be uniform except near the edges. If a frame be suspended in the air space as shown, and if this carries a current in the direction indicated, the parts of the frame in the annular spaces will experience mechanical forces, and the directions of these will be as shown; they will be equal to one another and proportional to the current only, pro-

vided the frame is well inside the annulus. Thus a "deflecting" couple will result which is proportional to the current, or can be expressed as $k_1 I$.

If this alone acted, the frame would be driven outside the annular space, but in the instrument it is suspended by a torsion wire so that as it turns it experiences a controlling couple which is proportional to the angle of twist, or is $k_2 \alpha$. When the frame is in equilibrium again, the two couples must be equal, and this at once gives $k_1 I = k_2 \alpha$ or $I = k \alpha$, where $k = k_2/k_1$, that is the angle of deflection of the coil is proportional to the current. This angle can be measured by the use of a pointer or a telescope and scale. The constant k is called "the steady current constant of the galvanometer." The frame can have many turns of wire on it, and any control which is proportional to the angle can be used. The student will find many varieties of this galvanometer in the laboratory, and the details of construction can best be studied there.

19. Ballistic use of galvanometer. Let such a galvanometer be joined to a battery and a key, and let the key be tapped and let go at once. The coil will swing out from rest through an angle which we shall call θ , will then turn and swing back through its zero position, and after a succession of gradually diminishing swings it will eventually come to rest in its original position. The coil has received a kick and the first angle of elongation is called the fling. We must see what quantity it is that is measured by this fling.

It is evident that just as the key went down and just as it lifted the current was zero, but during the small time T that the key was down, a current must have flowed, rising quickly to a maximum and then quickly falling to zero somewhat as shown in Fig. 12 where current is plotted against time. The electrical quantity concerned in the fling is the area of that curve, or the "Quantity" of electricity displaced round the circuit in the time T ; we must now correlate this with the fling. For each value of the current I , flowing at any instant during the time T , there will be a corresponding couple, $k_1 I$, on the coil. The mean couple for the time T is manifestly $\frac{1}{T} \int_0^T k_1 I dt$ which reduces to $k_1 Q/T$ where Q denotes the "quantity" of electricity displaced. When a force of mean

value F acts for a time T on a mass M the mass acquires a velocity v and these quantities are related by the equation $FT = Mv$. If the body can only rotate, and if the moving agent is a couple of mean value L , the body acquires an angular velocity Ω instead of a linear one, and if K is the moment of inertia of the body about the axis of rotation the corresponding relation is $LT = K\Omega$. But we have seen that in the case of the galvanometer coil the mean value of the couple is equal to k_1Q/T . Hence we have at once $k_1Q = K\Omega$, where K is the moment of inertia of the coil about its axis of suspension. The value of K should be sufficiently large to prevent any appreciable change of position in the time T , and to give the coil a sufficiently slow period of oscillation to enable the fling to be read conveniently. When the current has passed the coil is just moving off with angular velocity Ω , and its kinetic energy is $\frac{1}{2}K\Omega^2$. As it swings out towards its first elongation the kinetic energy is absorbed by the twisted wire, and as the couple due to twist increases uniformly with the angle from zero to $k_2\theta$, the average value of the couple is $\frac{1}{2}k_2\theta$ and the energy stored in the wire when the coil first comes to rest is $\frac{1}{2}k_2\theta^2$. If we assume that no energy is lost during the motion we have $\frac{1}{2}k_2\theta^2 = \frac{1}{2}K\Omega^2$ or $\Omega = \sqrt{\frac{k_2}{K}}\theta$ and, since $k_1Q = K\Omega$, we have further $Q = \frac{K}{k_1}\Omega = \frac{\sqrt{k_2K}}{k_1}\theta$. Hence we see that the fling θ measures the Quantity of Electricity which passed through the coil during the short time of depression of the key.

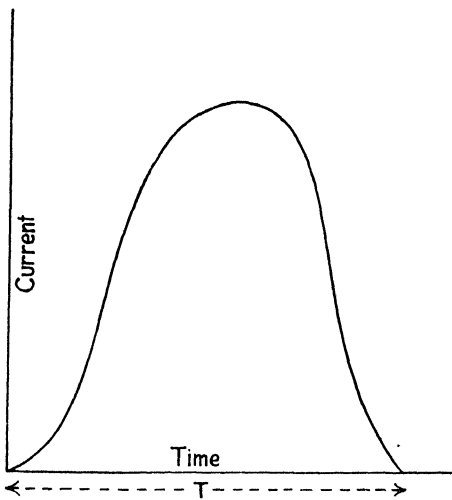

Fig. 12

A more convenient form can be derived as follows. When the coil is left to itself it will swing to and fro, and will have a periodic time given by $P = 2\pi\sqrt{K/k_2}$, since the controlling couple per

radian is k_2 . Hence we have $Q = \frac{P}{2\pi} \frac{k_2}{k_1} \theta$. But k_2/k_1 is the steady current constant k , so that finally we can write $Q = \frac{P}{2\pi} k\theta$.

It may be here noted that the assumption that there is no loss of energy during the first swing is untrue; we shall see later on that the expression must be slightly modified to allow for this, but the formula given is sufficiently accurate for the purpose in view.

20. The Magnetic Displacement. Let us be provided with a reasonably long ball-ended magnet which has a winding round it, the winding being in series with a battery and a key so that a current can be passed at will. When the current is flowing it becomes a magnet, and when the current is broken it will lose practically all its magnetism, if it be made of suitably "soft" iron. When a definite current is flowing, the poles will have some definite strength.

Let a small coil be placed near to and facing one of the poles, its axis lying in line with the axis of the magnet, and its ends being joined up to a ballistic galvanometer. If the key be depressed so that a current passes in the magnet winding a fling will be observed on the galvanometer showing that electricity has been displaced round the coil; on breaking the current, an equal and opposite fling will be observed, but so long as the magnet remains steadily excited, no effect is produced. The effect is just as if something pushed into the coil had shaken loose a current round it. This concept of a displacement through the coil will be strengthened if we arrange that the coil can be orientated in such a way that its axis makes known angles with the original direction, for then the flings will be found to be proportional to the cosine of the angle between the new and the old directions of the axis, which is exactly what we should expect if something radiating from the pole of the magnet had been pushed through the coil. Again, if the number of turns in the coil is varied the flings will vary in the same ratio. Let us then assume that such a displacement from the pole takes place, the thing displaced being called Magnetism; this displacement is more usually called a Flux of Magnetism.

It should be carefully noted that this new concept is altogether independent of the former one of a Magnetic Force, though we shall see later on how they can be correlated.

21. The Induction. If we consider a unit area perpendicular to the direction of the displacement, the amount of the displacement which crosses this area is called the Magnetic Induction or, more shortly, the Induction. It is denoted by the letter B , and we must now see in what units we can measure it.

It will be manifest that a single spherical pole will give a displacement which is radial, being pushed across concentric spheres with the pole at the centre. In this case the induction will vary inversely as the square of the distance, since the total displacement of magnetism must be the same across all the spherical coats, and their areas vary as the squares of the distance. Hence this new quantity, the Induction, varies numerically in the same way as did the magnetic force, H . As far as this numerical relation holds we can put $B \propto H$. But it must be carefully borne in mind that the relation is only numerical, and depends on the fact that for the present the magnetic phenomena are being considered as taking place in air or more strictly in a vacuum. The two things H and B are different in nature, the first can only be added up along a line, the second over a surface.

We may now however make an arbitrary selection of a unit of Induction. For we can put $B = \lambda H$ where λ is any number, the selection of this number being purely a matter of convenience. For many reasons 4π would have been a very convenient number, but the usual value taken is unity, so that *in a vacuum* we have $B = H$. It must be reiterated that this equality does not connote identity; it has led to a good deal of confusion in the matter. It further results that the unit induction will exist where the magnetic force is unity or one Gauss. This unit of induction is called a Maxwell or more commonly a Line-of-Force, the latter being a somewhat misleading term whose origin will appear shortly. But a unit pole will evidently produce unit H , and therefore unit B , at unit distance off, so that the unit of flux is that proceeding through one square centimeter of a unit sphere surrounding a unit pole. (If the factor 4π had been selected, the unit of induction would have been the total flux from that pole, a simpler thing to deal with.) It immediately follows that the total flux or displacement from the unit pole is 4π Maxwells, and hence that the total flux from a pole of strength m will be $4\pi m$. The symbol used for this total flux is ϕ , so that for any pole we have

$$\phi = 4\pi m.$$

22. Lines of Force. We have seen that the direction of the magnetic force and that of the displacement of magnetism coincide. In the case of the single pole, both directions are radial, but the nature of the displacement will manifestly be shown in any case, however complex, by means of lines plotted as shown in Figs. 4 and 5. For those lines give the successive and continuous directions of H , and hence the direction of the displacement of flux at every point. We can now find a quantitative interpretation of these lines. Let us suppose that we trace out on any one of the poles in the figure a small area such that the displacement across it is unity, or one maxwell. Round the periphery of this area we could start tracing a set of lines in the way described, and each would end on a pole of opposite polarity, so that we should map out a tube-shaped volume stretching from one pole to the other. This volume would have the property that the displacement across any section was unity also, since no displacement of magnetism can take place except along a line. Such a tube is called a Tube of Force, or more properly a Tube of Induction, and since it has unit displacement everywhere, it is called a Unit Tube. The state of the flux as regards magnitude or density would then be shown at once by the number of such tubes which are cut by a square centimeter held perpendicular to their direction. Let each tube have a line traced along its axis; this line can be taken to stand for the tube along which it is stretched, and we can call it a Line of Force, but this term must be looked on as meaning nothing more than what has just been stated. The use of the word Force in this connection is very liable to cause confusion, and although the phrase Line of Force means just the same as the word maxwell, the latter is very rarely used, while the term Line of Force is almost universally employed. The student must make this point quite clear to himself.

With these limitations we can use the Figs. 4 and 5 to give a quantitative as well as a qualitative view of the state of the flux in the space mapped out. The total flux ϕ passing across any area will then be measured in terms of these lines of force, the Induction B will be the number of such lines per unit area, and if the area perpendicular to the flux be s square centimeters, we have $\phi = Bs$.

23. The induced E.M.F. In the experiment we have been discussing we saw that the sudden excitation of the magnet caused a displacement of something, which we have agreed to call a Flux

of magnetism, through the coil, the effect being evidenced and measured by the fling of the ballistic galvanometer in series with the coil. We also saw that an equal and opposite effect is produced when the excitation of the magnet is suddenly annulled, and further that the effect in the coil is proportional to the number of its turns. The same effects will be observed if instead of producing the displacement exciting the ball-ended magnet we thrust one end of a permanent bar magnet through the coil, and the reverse effect will accompany the withdrawal of the magnet.

We must now investigate what is happening in the coil itself. If the coil has N similarly situated turns and if the flux through one of them is ϕ the quantity passing round the circuit, as measured by the fling, is proportional to ϕN . This product may be called the Flux-Turns and will be represented by the symbol ψ . Now let us put a resistance box in series with the coil and galvanometer circuit, so that we can vary the resistance of the circuit, and observe the flings of the galvanometer when the same change of induction is produced with different resistances in the circuit. The change can be readily produced by suddenly pulling a magnet out of the coil. It will be found that the flings, and therefore the quantities passing round the circuit, are inversely proportional to the total resistance of the whole circuit formed of coil, box and galvanometer. Hence we have $Q \propto \phi N/R$. But our units of quantity and resistance will be taken as "absolute" values, and since the flux unit is directly related to the absolute unit of current, we can replace the proportional sign by equality giving

$$Q = \frac{\phi N}{R}.$$

It is usual to measure the quantity in coulombs or 10^{-1} absolute units and the resistance in ohms or 10^{-9} absolute units, but the flux itself is commonly kept in absolute units or lines of force; the equation is then

$$Q = \frac{\phi N}{R} \times 10^{-8}.$$

At every instant during the passage of the quantity round the circuit there must be a definite current i , such as is shown in Fig. 12. Since the circuit has a resistance R ohms, a pressure of the amount Ri must be present in the coil to cause the current to flow. But we have $Q = \frac{\phi N}{R}$, and the current i is the rate of change of Q , hence

$i = \frac{dQ}{dt} = \frac{Nd\phi}{R dt}$ and the value of the E.M.F. that is required is given by $Nd\phi/dt$. This is the expression for Faraday's law, namely, *Whenever the flux changes in a circuit, an E.M.F. is produced which is equal to the rate of change of the flux-turns.* The direction of this E.M.F. must evidently be such as to tend to send a current in a direction to oppose the change of flux, hence we should prefix the minus sign, so that the E.M.F. is really given by $-Nd\phi/dt$. These two results are of primary importance in all electromagnetic work.

24. Magnetic Potential of a coil. An interesting deduction may be made at this point. At any instant the rate of doing work in the coil is I^2R or EI or $IN \frac{d\phi}{dt}$. This work must be supplied by the agent causing the change of flux. Let us suppose that the change is being made by the actual motion of a magnetic pole from which the flux proceeds. Let its velocity be v and let the force required to move the pole against the force due to the reaction between the pole and the current be f . The rate of doing work is fv and if dx be the small distance moved in the small time dt , we have $fv = fdx/dt = INd\phi/dt$. We at once deduce that the mechanical force on the magnet, in the line of its motion, that is in the direction in which dx is measured, is $f = INd\phi/dx$ dynes.

This result can be carried further. Suppose that the magnet is a ball-ended one, and let a sphere of unit radius be circumscribed round the pole as in Fig. 13. If radii be drawn from the boundary of the coil to the pole they will cut off an area on this unit sphere. This area is called the Solid Angle subtended by the coil at the pole, and is denoted by the letter ω . We have now a simple expression for the flux through the coil. For since the total flux from a pole is $4\pi m$ and since the area of the unit sphere is 4π , the flux that gets into a single turn of the coil is manifestly $m\omega$.

Now the field due to any given current in the coil will be the same whether the current is due to the motion of a magnetic pole near the coil or is maintained by some source, such as a battery, in the circuit of the coil. If for simplicity we consider a coil of one turn and of any shape, carrying a current I , we see that the expression $Id\phi/dx$ for the mechanical force on the pole becomes $Imd\omega/dx$ dynes. in the direction in which x is measured. Hence

if H is the strength of the field, or the magnetic force at the position occupied by the pole, in any direction specified by x , we see that $H = Id\omega/dx$. Now we have seen (p. 10) that the magnetic force due to a set of poles can be deduced from the linear rate of change of a quantity called the Potential, and we now see that the magnetic force due to the coil can be derived in the same way from a magnetic potential and that this has the value $V = I\omega$, for then $H = dV/dx = Id\phi/dx$.

Another important point is as follows. We saw that when a unit pole was carried along any path in the field due to a set of magnet poles the work done was the difference between the values

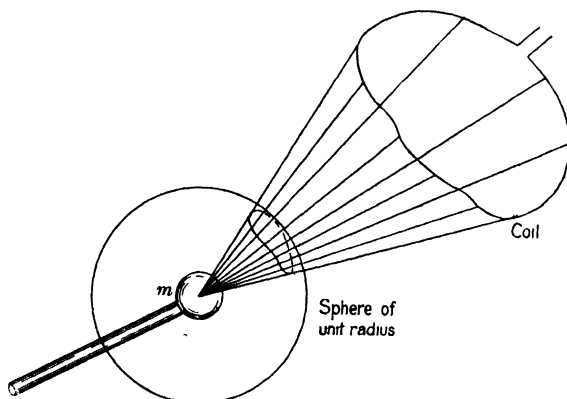

Fig. 13

of the potentials at the beginning and end of the path, and that in the complete traverse of a closed path no work was done: with the coil this is not always true. If we move our pole about in any way and bring it back again without threading the coil, the solid angle subtended will be the same, but whenever we thread the coil we manifestly sweep over the whole area of the little sphere, and the solid angle changes by 4π . Hence strictly speaking, the potential of the coil is $V = (n4\pi + \omega) I$. This does not of course affect the value of the magnetic force, which is dV/dx , but the work done, being the difference between the initial and final values of the potential, is increased by the amount $4\pi Im$ ergs every time a pole of strength m threads the coil carrying the current I .

This result is of considerable importance. It may be noted that

the values obtained for the magnetic force due to circular and linear wires can be readily deduced from these considerations, and it is a good exercise for the student to make these deductions.

25. Examples of Induced E.M.F.'s. We will now consider a few cases of induced E.M.F.'s, and will first take a simple form which will serve to make the principles clear. In Fig. 14 let AA and BB be two parallel bars distant l cm. apart and of practically zero resistance; let a bar PQ of resistance R be fixed across one end, and another bar XY of zero resistance be capable of sliding along the pair of bars. Let a flux of uniform and constant value B per square centimeter be maintained perpendicularly downwards through the paper. Let the bar XY be moved with constant velocity V cm. per second in the direction shown in Fig. 14. Its motion will cause the flux passing through the circuit to increase uniformly, and hence an E.M.F. will be produced and, as the circuit is closed, a constant current will flow, of the value I . As regards the direction of this current, it must flow in such a manner as to tend to prevent the flux from altering in amount, that is it must tend to cause a flux backwards in the opposite direction, to accomplish which the direction of the current must be as shown by the arrows on the bars; the accompanying E.M.F. existing in XY will have the direction of the arrow alongside the bar. As regards the magnitude of the current, I , this is given by our experimental fact that the quantity of electricity that passes round the circuit in a time t is equal to the flux added divided by the resistance of the circuit when the units are congruent, or all "absolute." This leads at once to the equation $BIVt = QR$, for Bt is the flux added per centimeter displacement, and V is the linear velocity. Further, since $Q = It$, it at once follows that $BIV = IR$. But as we have considered that the current is impelled by an E.M.F. produced by the bar XY cutting across a flux which is maintained constant and uniform in intensity, we can at once write $E = IR = BIV$ where E is the value of the induced E.M.F. in this arrangement. The expression is a very useful one, as many practical pieces of apparatus involve the production of an E.M.F. in this manner. If the value is required in volts, this expression must be divided by 10^8 .

A further result can now be established; there is a definite expenditure of power which is given by the expression I^2R or

(in terms of the induced e.m.f.) by EI . It at once follows that a mechanical force F must be applied to the bar XY , which must act exactly opposite to the direction shown by the arrow if it is to do work on the bar. With all the quantities expressed in the appropriate or c.g.s. units, we can equate the expressions for the rate of expenditure of energy and the rate of doing work on the bar, giving

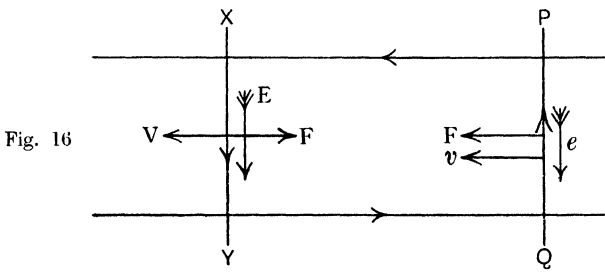
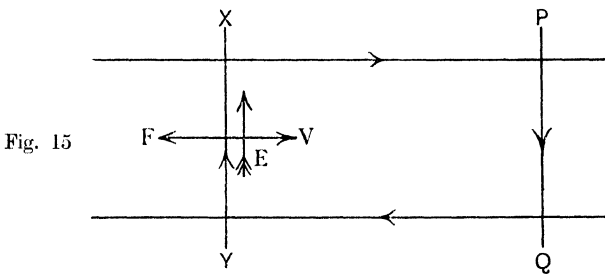
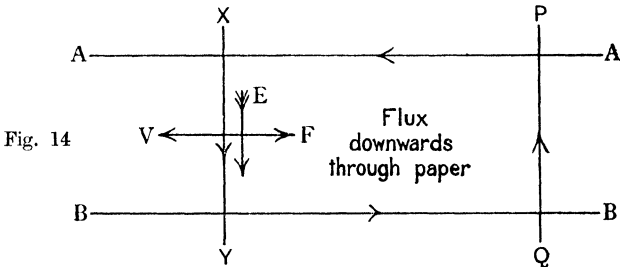

the relation $VF = EI$. This at once leads to $VF = BVI$ or $F = BI$, another very useful expression which follows from our fundamental assumption on p. 12. If the current be in practical units or ampères, the factor 10^{-1} must be used.

It is useful for the reader to follow out the consequences of moving the bar XY in the opposite direction as shown in Fig. 15. It will readily be seen that the relative directions of the quantities

involved are as indicated in that figure. If we consider the fixed bar PQ in Fig. 14, it will be seen that since it has in it the same current as in XY but in the opposite direction, and is experiencing the same magnetic field, it must be sustaining a force of the same value F as XY , but directed in the opposite way. Hence if released it will start moving with a velocity which we may denote by v and it will become the seat of an E.M.F. which will have the value $e = Blv$, and which will act in a direction parallel to the E.M.F. in XY , as shown in Fig. 16, and therefore in opposition to the direction of flow of the current. This is the so-called "back E.M.F." The bar XY is acting as a dynamo, a machine for turning mechanical work into electrical, the bar PQ is acting in the reverse way as a motor. The current which now flows will be determined by the fact that the two E.M.F.'s are impelling it against the resistance R , and hence we must have $E = e + IR$. It should be noticed that v must be less than V so that PQ is always falling behind XY . Further, since $E - e = IR$ we have $IR = Bl(V - v)$. So that if S be the alteration of distance between the bars in the time t , we have $IRt = BlS$ or $QR = BlS$, that is the product QR is still equal to the flux added to the circuit. If no resistance were present, the value of the current would be decided by the force demanded to move PQ and hence XY , but the two E.M.F.'s would then be practically equal, and the distance between the bars constant.

26. The E.M.F. of a dynamo. A simple and important example is the method in which the E.M.F. of a dynamo or motor is produced and utilised. Suppose that the poles of a horse-shoe magnet of rectangular section are bent round and bored out so as to form a partial cylinder as shown in Fig. 17. Let a cylinder, formed of a series of annular iron discs mounted on a spindle, be placed concentrically in the cylindrical space between the poles, and let a large number of straight insulated wires, laid parallel to the spindle, be fixed on the outside of this iron ring, each wire having a length of l cm. in the space between the poles. Suppose that the spindle carrying the iron ring to the wires be kept revolving at n revolutions per second, so that, if the wires form a cylinder of r cm. radius, the linear velocity of the wires is $v = 2\pi nr$ cm. per second. If ω be the angular velocity this may be written $v = \omega r$. The whole being symmetrically placed about the axis, the flux will proceed from the north pole, N , across the upper air-gap into

the iron ring, and from the ring, across the lower air-gap to the south pole, S , and the induction in the air-gap will be nearly uniform.

We see at once, from the relations we have just investigated, that all the wires which at any instant lie above the horizontal plane XX will have in them downward E.M.F.'s as indicated by the crosses, while the wires which at any instant lie below the line XX will have upward E.M.F.'s as indicated by the dots. The wires which are just crossing the line XX have no E.M.F. in them, and this line is therefore called the Neutral Axis.

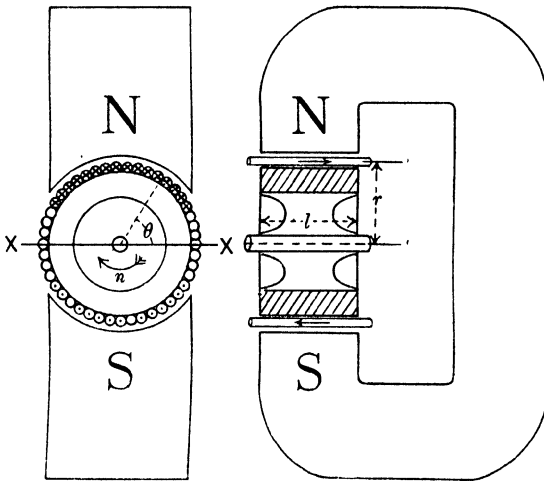

Fig. 17

We proceed to find the E.M.F. which would exist between the opposite points of the line XX if we could at any instant connect all the wires on the upper or the lower half of the cylinder in series, joining the left-hand end of each wire to the right-hand end of its neighbour, taken in order, by conductors which do not cut the flux, that is to find the sum of all the E.M.F.'s existing at any instant in the upper or lower layer of wires. Let the position of any wire, relative to XX , be given by the angle θ , and let the total number of wires on the cylinder be $2\pi\sigma$, so that σ is the number of wires per radian, and $\sigma d\theta$ the number in the small angle $d\theta$. If the induction at that point in the air-gap specified by the angle θ be B , the E.M.F. in one wire at that point will be Blv and the sum of

the E.M.F.'s for the wires in the angle $d\theta$ will be $Bl\omega d\theta$. The E.M.F. required, for the whole series from X to X , is therefore $\int_0^\pi Bl\omega d\theta$, or $\omega\sigma \int_0^\pi Blr d\theta$. But $lr d\theta$ is the area of the small strip of cylinder inside the angle $d\theta$, and $Blr d\theta$ is the flux which passes through this strip, so that the integral $\int_0^\pi Bl\omega d\theta$ is the whole flux emanating from the pole. Let this be denoted by ϕ and the total E.M.F. by E , then we have $E = \sigma\omega\phi$. This expression is sometimes written in a more convenient form as follows. Let z be the total number of wires, counted right round the ring, then $z = 2\pi\sigma$, and since $\omega = 2\pi n$ we have at once $E = \phi zn$. As before we must divide by 10^8 to express the E.M.F. in volts.

If a continuous wire be wound, as a helix, on the iron ring, as shown diagrammatically in Fig. 18, the outer portions will be connected in series in the required manner, and as the flux is practically confined to the iron, the inner layer of wires will not cut it, so that this arrangement satisfies the required conditions. Further, if we follow the wire for one complete circuit, we shall find the E.M.F.'s with us in one half of the circuit and against us in the other half, so that in the wire as a whole there is no resultant pressure, and therefore no local currents tending to cause internal waste of energy. Or, to state this in another way, relatively to the two points XX the E.M.F.'s in the two half circuits are in the same direction, that is the two half circuits act exactly as two cells placed in parallel between the points XX .

It remains to be seen in what manner it is possible to utilise the difference of pressure that we now see will always be present between the points X and X . One way would be to rub off the insulation from the outside of the ring of wires, and let a pair of brushes be kept pressed against the ring at those points, but this would be a very makeshift arrangement. Suppose that we build up another cylinder consisting of a series of insulated sectors, insulated both from one another and from the shaft, as is shown diagrammatically on a straight line base in Fig. 18, by the pieces marked C , and connect each of these pieces to one turn or more of the spiral on the ring by means of the connecting wires shown at W in the figure. A cylinder built up in this way is called a Commutator or Collector and gives a mechanically designed surface on which the brushes at X and X can press, while its effect is

manifestly the same as if the brushes pressed directly on the surface of the ring of wires. The form of winding considered here is rarely used in practice, but any method which secures that the way in which the wires on the cylinder are joined up does not depend on the position of the cylinder, and also that the nett pressure met on going round the winding is zero, will do just as well. Such methods will be found described in books on Dynamos.

It may be noted that the arrangement just considered may be used to produce E.M.F. in a different manner. Suppose that the

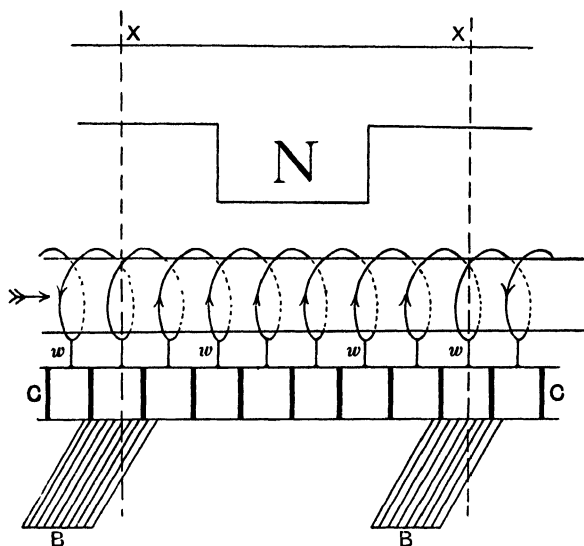

Fig. 18

complete ring of wires is not connected to a series of points round a commutator but has only two opposite points, which we will refer to as P and P , attached to a pair of insulated rings fixed to the shaft and that the brushes press against these rings. At the instant when P and P coincide in position with X and X the same E.M.F. will be acting as in the former arrangement, but when they are just midway round between X and X it will be seen that the various E.M.F.'s will just neutralise one another, so that there is no pressure between the rings. Again, when they have turned just halfway round, the points P and P will have reversed their positions relative to X and X , and hence the pressure between the rings will be the

same as before but with reversed sign. Hence on rotation the pressure between the rings will be alternately in opposite directions; such an E.M.F. is called an Alternating E.M.F.

27. Damping of a galvanometer. In deducing the expression for a ballistic galvanometer on page 22 it was assumed that as the coil swings on its first elongation the initial kinetic energy was completely stored in the twisted suspension, but this is not accurate. All the while the coil is moving it experiences mechanical resistance from setting the air in motion, and if it is connected to a closed circuit, it will be always experiencing in addition a change of magnetic flux and consequently have an induced current in it.

This current will interact with the magnetic field and give a couple opposing the motion of the coil. If the resistance is very low, this couple may be so great as actually to cause the coil to move slowly back to its zero without passing it, the galvanometer is then said to be dead beat, and in this state is of little use for ballistic work. But the property is taken advantage of to

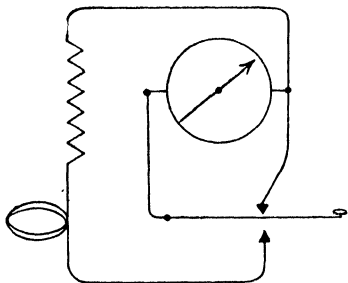

Fig. 19

bring the coil quickly to rest after the fling has been observed, this is done by connecting the galvanometer to a key as shown in Fig. 19, where it will be seen that on release of the key the galvanometer is automatically short circuited, and the coil is thus brought quickly to rest ready for another observation. If such a coil be started swinging, the successive rest points can be readily observed, and since these occur at equal time intervals, the curve connecting time and deviation from zero can be roughly plotted as in Fig. 20; the observed maxima can be observed and the line joining them drawn in as shown. It will be discovered that the consecutive heights a, b, c, d , etc. have the relations $a/b = b/c = c/d = d/e$, etc., that is they diminish in a constant ratio. Now the first elongation, or the observed "fling," is manifestly given by b , while the first swing if there had been no opposition would have been a . This effect of continuously diminishing swings is called "damping," and the factor by which the observed first fling b must be multiplied in order to get the perfect fling a is called "the Damping Factor" and

will be denoted by Δ . The value of Δ is evidently a/b or b/c or c/d , etc. But with a suitable instrument this ratio cannot be read directly, and further we do not generally have the zero of the galvanometer in the middle of the range, but at one end; in fact in practice we can only read such swings as b and f , on the same side of zero. But it will be seen at once that the constancy of the ratio gives immediately $\Delta = \sqrt[4]{b/f}$.

If b and f are so nearly equal that their ratio cannot be accurately determined we can proceed as follows. It is essential to read b as it is the first fling, but instead of the second swing on the same side we read the n -th swing on that side and call it b_n . It follows from

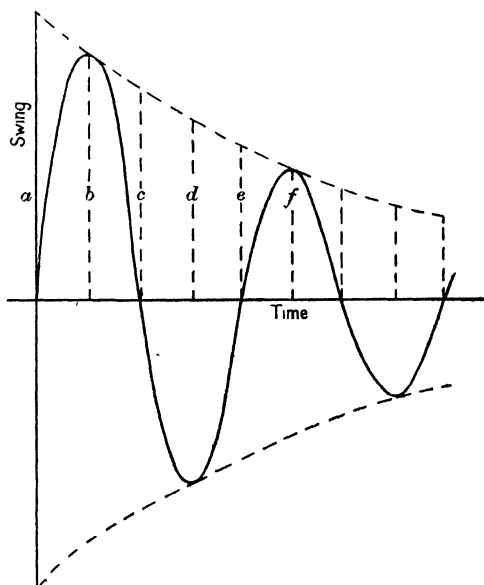

Fig. 20

the above that $\Delta = \sqrt[4]{\frac{b}{b_n}}$. It is thus quite easy to correct the observed first fling for damping, and the full expression for the ballistic galvanometer is then $Q = \frac{P}{2\pi} k\Delta\theta$. It must be noted that the value of Δ depends essentially on the resistance of the circuit, and it is a useful experiment to find the relation between

Δ and R . Another point is that so long as the resistance is constant so is the value of Δ ; hence if the precaution be taken to keep the resistance of the circuit fixed during any test, we can take Δ as part of the constant of the galvanometer, and thus, we have:

If the resistance of the galvanometer circuit be kept constant in any test, the relation $Q \propto \theta$ holds good.

28. Flux measurement. We have found that the relation between ϕ , the change of flux through a coil, and Q , the quantity displaced round the coil is given by $Q = N\phi/R$. It follows that, under the same condition of fixed resistance of the coil's circuit, we have the change of flux, $N\phi$, through the N turns of the coil, proportional to the fling θ .

In all magnetic tests, then, we should aim at keeping the resistance of any circuit in which the flux changes are to be measured at a constant value throughout, and then we have the simple relation $\phi = k\theta/N$.

29. The Standard Field. We must now see how we can provide a standard of magnetic flux. The most generally useful one is that known as a Mutual Inductance or Standard Field, and a simple and convenient form is made as follows. Take a uniform tube of brass say about two feet long and three inches in diameter, wind on it very carefully one or two layers of wire, noting the total turns and the exact length covered by the wires, and let the turns of wire per centimeter be N . On an ebonite bobbin which will just fit inside the tube wind a small coil of n turns and mean radius r cm. Suppose that a current of one absolute unit is flowing in the main coil, and that θ is the angle subtended by the end radius of the brass tube at its mid-point, where the little bobbin must be placed, then the magnetic force at the mid-point of the tube is given by $4\pi N \cos \theta$. This must also be the induction at that point, and since the length of the tube is great compared with its radius, the induction will be practically uniform all over the central cross-section, and, for unit current in the main coil, the flux-turns in the bobbin, which has n turns each of area πr^2 sq. cm. will be $4\pi^2 N n r^2 \cos \theta$. If the unit of current is an ampère, this number must be divided by ten. We have now secured a standard of flux and can use it to measure other fluxes by means of a ballistic galvanometer.

When used for this purpose the current in the main, or primary, circuit is usually reversed in direction by a suitable switch, so that the change of flux in the smaller or secondary coil is twice that given above. This number is a constant for the apparatus and all the quantities involved can be readily measured; let it be denoted by the symbol Ψ_s , and called the "flux-turns for unit current."

30. Magnetic Bodies. We have assumed that in a vacuum the induction is equal to the magnetic force, that is $B = H$. We must now examine whether this is true for other substances.

Provide a series of rings each of axial length l and of circular cross-section S . Some of these should be solid rings of different metals and alloys, others made of thin brass tube can be filled with various gases. Wind each of the rings with two coils, a primary of N turns to carry a magnetising current, and a secondary of n turns to test the flux changes by means of a ballistic galvanometer. Provide also a standard field, and connect the circuits up as shown in Fig. 21. The two way plug P

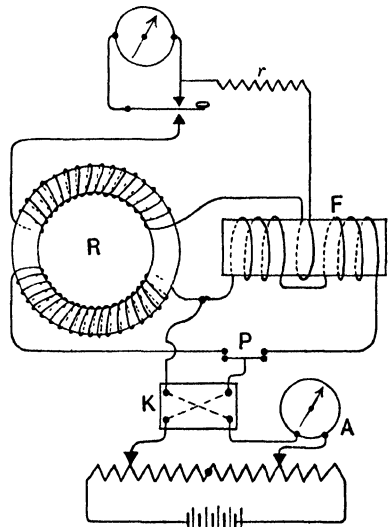

Fig. 21

enables us to send the current, measured by the ammeter A , through the primary coil of either the standard field F or of the ring R . The current can be reversed by the reversing key K , and the resistance box r can be adjusted to give convenient flings, but must on no account be altered during the trials.

The two quantities required are the magnetic force acting on the ring, and the induction in it. The former is found for any current and for each ring as follows. Suppose that a current I is flowing round the primary circuit of the ring, the value of H is practically that due to an endless solenoid, and is given by $4\pi IN/10l$, if I be in amperes. It is therefore a mere multiple of the current round the

primary of the ring and can be tabulated alongside any selected set of currents.

The induction can be found as follows. Send a current I_s round the primary of the standard field, whose constant Ψ_s has already been calculated. Reverse the current, and read the fling, θ_s , produced on the galvanometer. The change of flux-turns in the galvanometer circuit is $2\Psi_s I_s$. Now send any one of the selected currents round the ring, reverse it, and observe the fling, θ . If B is the value of the induction in the ring, the flux is BS , the number of flux-turns in the galvanometer circuit is BSn , and the change of flux-turns on reversal of the current is $2BSn$. But the resistance of the galvanometer circuit has been kept fixed, hence we have at once

$$\frac{2BSn}{2\Psi_s I_s} = \frac{\theta}{\theta_s} \quad \text{or} \quad B = \left[\frac{\Psi_s I_s}{Sn\theta_s} \right] \theta.$$

The expression in the bracket is again a fixed constant, and if the flings be tabulated alongside the currents which are reversed, we can add immediately a column for the values of B . Hence we have the corresponding values of B and H side by side.

If this experiment is carefully performed it will be found that the great majority of substances give the same relation as that assumed for vacuum, namely $B = H$. Such substances are somewhat inappropriately called Non-magnetic. A few substances will give values of B which are many times the corresponding values of H , these are called Paramagnetic, or more shortly, Magnetic; they include the group of metals iron, cobalt and nickel and certain alloys of manganese and other metals which separately are non-magnetic. A third group will be found, containing such metals as bismuth, in which the induction is less than H , these are called Dia-magnetic. For our purpose the only ones that have to be considered are iron and certain of its alloys. Information on the other points must be sought for in books on Physics.

31. Typical curves. A curve representing the relation between B and H , obtained in this way, is called the B — H or Reversal Curve of the substance. Figs. 22, 23, and 24 show some typical forms for a few important sorts of iron and iron alloys and for different ranges of H . To obtain such curves as those shown we must take special precautions which will be referred to later on.

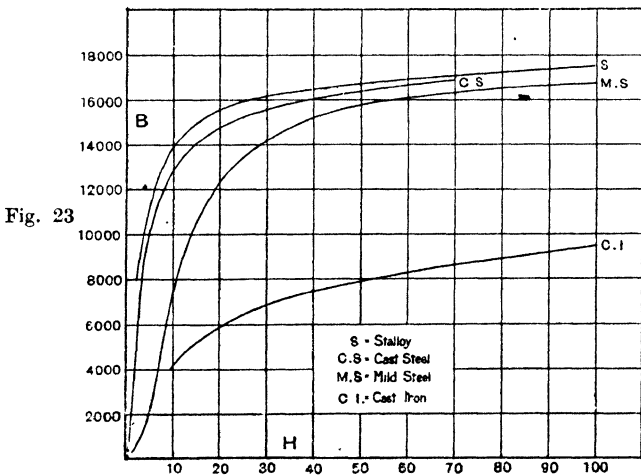
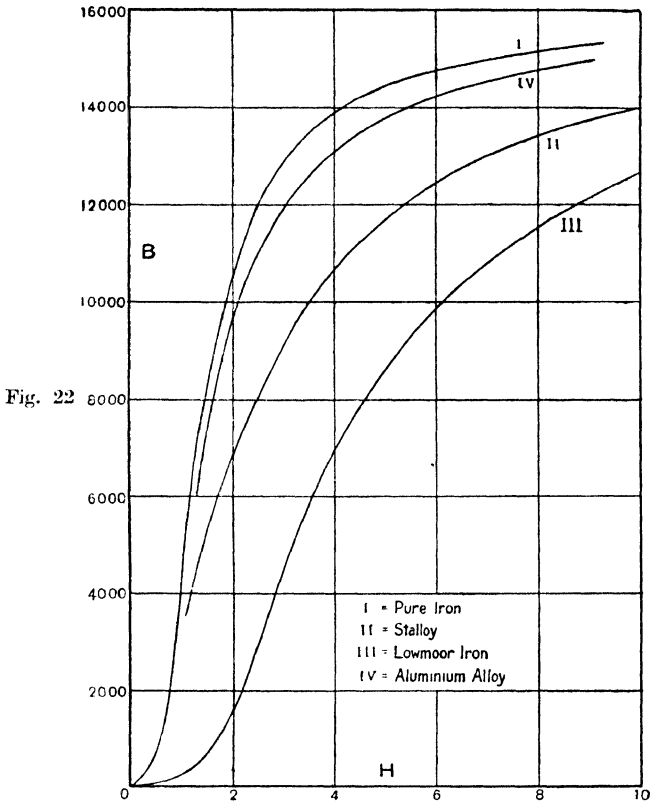

MAGNETISM

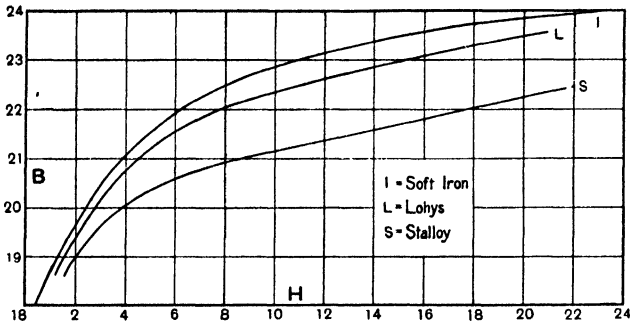

Fig. 24. H is measured in hundreds, B in thousands

32. Permeability. It will be seen that in iron the induction is many times larger than the magnetic force, the iron behaving as if it could offer little opposition to the magnetising action of the latter. It is convenient to express this effect by the ratio of the

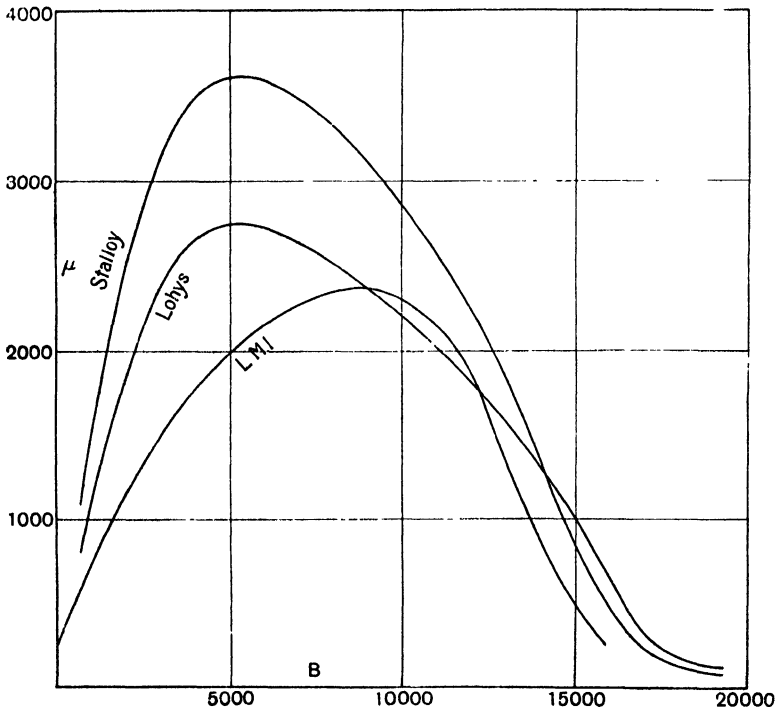

Fig. 25

actual induction produced to that which the same magnetic force would have produced in vacuum. This ratio is called the permeability and is denoted by the letter μ , so that we can write $\mu = B/H$. But with the definition we have used, the letter " H " must be taken to represent the induction corresponding to the magnetic force acting on a vacuum; if we take it to be the magnetic force itself, the permeability must no longer be regarded as a number, but as a new physical quantity of different dimensions from either B or H . For the beginner, the former method of regarding the question is simpler. The permeability can be plotted either in relation to H or to B , in most cases the latter proceeding is the more convenient (Fig. 25). Sometimes the reciprocal of μ , called the Reluctivity and denoted by ρ , is used. The student should plot the ρ — B curve from Fig. 25.

33. Derived units of flux and magnetic force. In addition to the maxwell as the unit of flux and the gauss as the unit of magnetic force, certain derived units are commonly employed in dynamo design corresponding to the practical units of current and pressure derived from the absolute units. Thus fluxes are measured in terms of the kilo-line or 1000 maxwells, the mega-line or 10^6 maxwells, the volt-line or 10^8 maxwells and even the kapp-line or 6000 maxwells. The object of these units is to avoid the use of large numbers in expressing the values of fluxes or inductions. Thus (p. 32) we have seen that in a dynamo in which the polar flux is ϕ absolute units, the peripheral wires z , and the revolutions per second n , the E.M.F. produced is given by $E = \phi zn$ absolute units or $E = \phi zn 10^{-8}$ volts. If ϕ is expressed in mega-lines this becomes $E = \phi zn 10^{-2}$ volts, and if in volt-lines it is $E = \phi zn$ volts. At the same time the use of smaller numbers to express the flux reduces the risk of arithmetical mistakes. The kapp-line is used when n gives the revolutions per *minute*, and we then have $E = \phi zn 10^{-6}$ volts. Occasionally in expressing induction the unit is referred to the square inch instead of to the square centimeter.

Magnetic Force is very commonly expressed in ampère turns per centimeter (A.T. per cm.) or in ampère turns per inch (A.T. per in.). When I is expressed in absolute units and N the total turns in the winding we have

$$H = 4\pi IN/l = \frac{4\pi}{10} I_a N/l$$

where I_a measures the current in ampères. But $I_a N/l$ is the ampère turns per centimeter and we thus have A.T. per cm. = $\frac{10}{4\pi} H = 0.794H$, which is near enough to $0.8H$ for practical purposes. Similarly we can show that A.T. per in. = $2.02H$. It must be carefully noted that when these mixed units are used B is no longer equal to H in air or a vacuum, that is the permeability of air is no longer unity. For example if the induction be measured in maxwells per square inch and the magnetic force in A.T. per in. the permeability of air is $6.45/2.02$ or 3.2 , or A.T. per in. for air is $0.314B$, where B is expressed in maxwells per square inch.

34. Forms of specimen. The form of specimen we have considered is a torus or anchor ring; this is difficult to make and is not commonly used. If a ring be used it is usually of rectangular cross-section, and should be of large radius so that the ampère turns per centimeter-run inside and outside are as near as possible the same. If it be impossible to secure a ring, rods can be used, but this involves some method of joining the ends, a more complex matter which must be left for the present. A very usual form of specimen is that of a set of thin strips; these can be assembled in four equal packets and placed inside four fixed tubes which are already wound with proper primary and secondary windings, and are thus always available for use. The ends of the parcels have the separate strips interleaved to make the path of the flux easy. In such a square, the magnetic force is not truly uniform, but it can be made very nearly so by a suitable method of winding the coils. For details the student should consult a paper by Dr Searle (No. 15). It may be noted that the dimensions of ordinary rings and rods can be measured with the usual micrometers, etc., but the thickness of the iron strips used in the last form should be measured by a specific gravity method.

35. Form of the $B-H$ curves. On referring to Figs. 22 to 24 it will be seen that the $B-H$ curves have three principal regions, an Initial part where B grows rapidly with H , a Knee at which μ is a maximum, and a nearly straight part well above the knee, which is called the region of Saturation. For engineering purposes the most useful part of these curves is the part beyond the knee, but it is of some interest to examine the form of the

initial part. In Fig. 26 is given the very early part of a curve; it will be noticed that it does not start off at a tangent to the axis but at a definite slope, showing that the permeability has a definite value to begin with. The curves of the steels are more roundly shaped than those of pure iron and some of the non-metallic alloyed

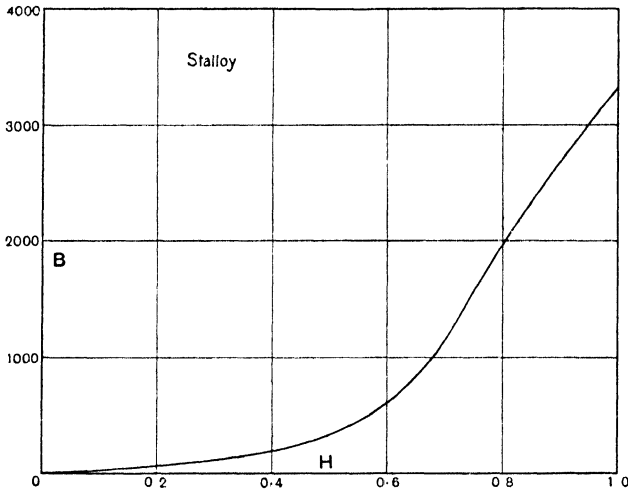

Fig. 26

steels. The other end of the curve, or the saturation part, cannot be fully investigated by the method we have considered, as it is impossible to crowd on the specimen the number of coils of wire required to provide sufficient ampère turns for the high magnetic forces involved. Hence we must use another method.

36. High Inductions. This method consists in placing the specimen between the poles of a strong electromagnet as shown in Fig. 27. This magnet is wound with a large number of turns, and the flux from it is crowded into the strip under test, which thus becomes highly magnetised. But we can no longer measure the magnetic force by means of the current and turns on the magnet, as this current has to magnetise the magnet as well as the strip. The induction in the strip is readily found in the ordinary way by means of a coil wound on it, the fling on reversal being read on the ballistic galvanometer. To find the value of H we must devise a special arrangement.

The arrangement, due to Dr Beattie, is shown in Fig. 28. On a very thin copper former is wound a very carefully made coil of known number of turns: we will call this the X coil. Two thin pieces of fibre are fixed outside this and a second coil having an equal number of turns is wound over the whole: this we will call the Y coil. The areas of the two coils are found by placing them in a strong and uniform magnetic field of known value, and

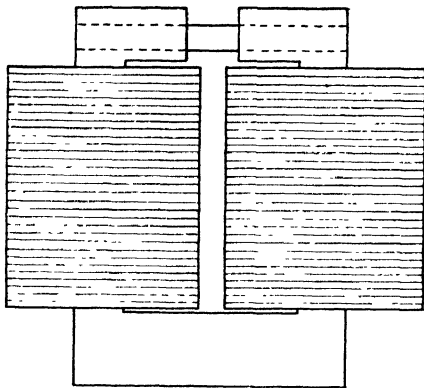

Fig. 27

observing the flings for each on a calibrated galvanometer when the field is suddenly removed. Let the areas be x for the X coil and y for the Y coil. The specimen must just pass into the X coil, and hence its cross-section a , which can be measured, must be less than x . The big magnet produces a field which is uniform over the small area occupied by the coils. Join up X and Y differentially, and measure the flux change in the ordinary way: evidently the induction inside the X coil cuts out, since the coils oppose, and we consequently have an induction equal to the required H passing through the known area ($y - x$). From this we at once derive the value of H . Now the X coil embraces more than the induction in the iron, for it also encloses a space of area ($x - a$) in which the induction is H , hence if we take the fling with the X coil only, and find the flux denoted by the fling, we must deduct the amount of flux given by $H(x - a)$, the remainder divided by a is the required induction. The curves given in Fig. 24 were found in this manner.

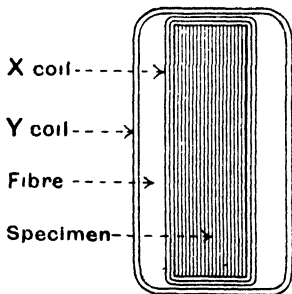

Fig. 28

By such an apparatus it is possible to push the iron up to the highest inductions used in engineering work. If still higher values

are required, another method must be used, which will be found described in works on physics. The ordinary ring method of test can be carried up to $H = 250$ without much difficulty, and with special cooling up to about $H = 1000$. The second method can be used up to nearly 3000, but the special method last alluded to enables magnetic forces up to nearly 25,000 to be employed. Although such high magnetic forces are not required in practice, the result is interesting. It is found that for values of H higher than from 5000 to 6000 the $B-H$ curve is practically straight, and that it can be written in the form $B = B_s + H$, so that the increase in induction is due merely to the increase of magnetic force and is equal to it. The value B_s is thus the true "saturation" value of the induction; the iron itself has, so to speak, done all it can in carrying flux. The value of this quantity for pure iron is about 21,000. Another interesting point is as follows: in many alloys the saturation value B_s varies in proportion to the amount of iron in the alloy, so that the alloying body acts as a dilutant only. Thus with silicon, B falls about $2\frac{1}{2}$ per cent. for each 1 per cent. of silicon present. With carbon the relation is more complicated as certain of the iron-carbon alloys are themselves magnetic, but within certain limits the same result is found (see paper 6).

37. Effects of temperature, etc. The effects of heating, straining, and of other treatment are extremely interesting, but only one or two of these effects are of importance for our purpose; the others can be studied in Ewing's *Magnetism*. Effect of strain, however, is of much importance as unavoidable straining effect is involved in the process of shearing the thin plates used in making many kinds of apparatus. The following experiment, which is due to Dr Scarle, shows the effect of a shear strain. A set of strips was made into a square as described on page 42 and a test of the $B-H$ curve was made from which was derived the top curve of Fig. 29 connecting μ and H . The strips were then taken apart, and with a pair of shears a longitudinal cut was made in each strip, nearly separating it into two. The whole set was put together and re-tested, with the result shown in the middle curve. On repetition, with a second cut along a second line, the lower curve was found. These curves show a progressive diminution of permeability. This is called magnetic "hardening" of the iron. Similar results occur with simple stretch, with torsion, and with other forms of strain,

so that the greatest care must be taken in handling iron to avoid any unnecessary strains being left. The effect of the overstrain can be removed almost entirely by suitably raising the temperature, but this must be done with caution: this restoration of magnetic properties on heating is called "annealing." In some cases the converse effect can be produced, excessive "hardening" may be imposed by heating the steel to a high temperature and suddenly quenching it.

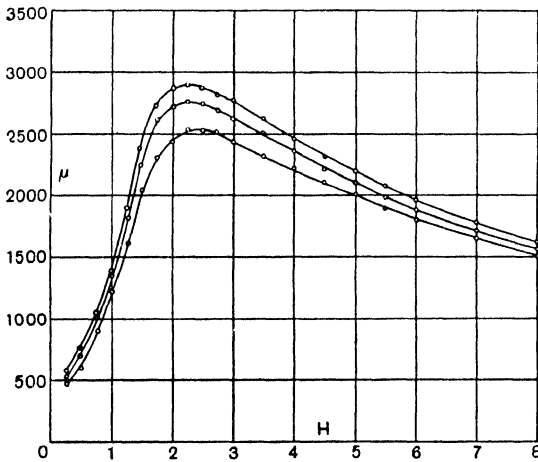

Fig. 29

38. The Cyclic Curve. Hitherto we have supposed that the relation between B and H has been obtained by subjecting the iron to a set of currents increasing in value, reversing each, and deducing the induction existing at each current. We must now see how the iron behaves if we gradually change the current from a positive value to an equal negative value, not in one jump, but in a set of steps. Suppose we connect the ring to a potential slide as shown in Fig. 30. A steady current is kept flowing in the wire, and it follows that when the moving point P is at A a certain maximum positive current will flow round the ring, when P is at C there will be no current, and when P is at B a current will flow equal to that at A , but in the opposite direction, BC being equal to AC . The circuit, other than the ring, is not shown; it would be just as given in Fig. 21 so that, as there, we can find the magnetic force from the reading of the ammeter, and any change in flux from

the fling of the ballistic galvanometer. Hence for convenience we can speak of the H produced by the current, and of the alteration of induction caused in the ring, instead of always referring to the current and the fling.

Let a maximum current and corresponding H be applied: then suddenly shift the point P a short distance along the wire, the current and H will fall, and there will be a fling showing a change of

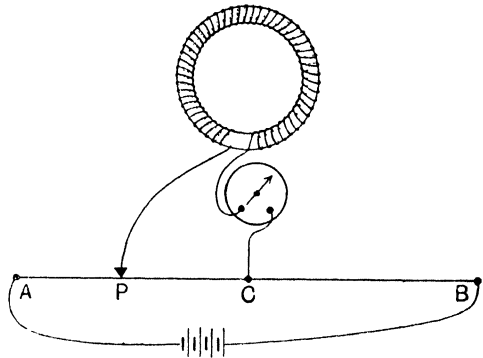

Fig. 30

induction δB . A second further sudden jump of P will cause another current to flow, and a second fling showing a further change in B . In this way we can proceed by a series of jumps until finally we arrive at the point B on the slide, the value of H being then equal and opposite to the initial value. These results, for a certain ring, are given below in the columns headed H and δB , in the annexed table.

H	δB	B
6.45	0	9030
4.63	200	8830
3.24	200	8630
2.19	260	8370
1.33	270	8100
0	670	7430
-0.68	600	6830
-1.36	940	5890
-2.05	2470	3420
-2.73	4670	-1250
-3.41	3210	-4460
-4.09	1730	-6190
-4.78	1010	-7200
-5.63	1100	-8300
-6.45	730	-9030
18060		

If the separate changes of induction over the whole range be added up they amount to 18,060. Now we can assume that the

induction is the same at both extreme values of H , and hence the initial induction is half the total change, that is 9030. This is set down at the head of the last column, and the remaining values of B deduced by subtracting the changes of induction given in the second column. We thus have a series of simultaneous values of B and H . These are plotted in Fig. 31 along $PADQ$. If we reverse the process from Q to P we obtain the dotted curve, $QCEP$ which is the same

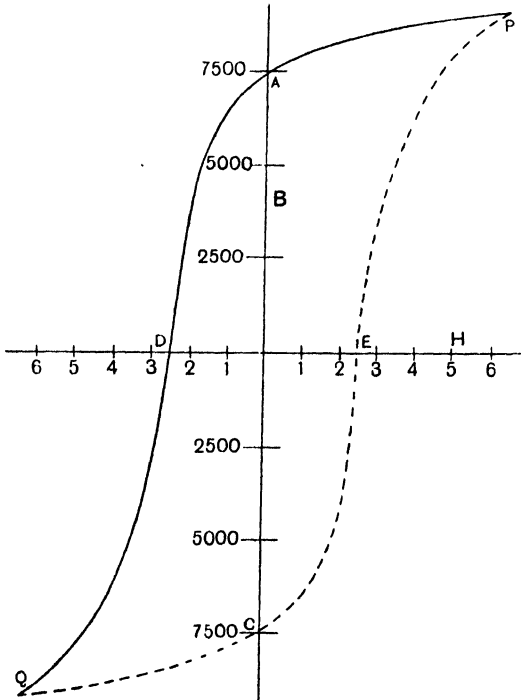

Fig. 31

as the first: the whole curve is called a cyclic curve, and the ring is said to pass through a magnetic cycle. The principal points are the maxima and the pairs of points A , C and D , E . The former give what is called the Remanent Induction, that is the induction left when H is zero: the latter give the Coercive Force, namely the value of H required to reduce the induction to zero. A person well acquainted with the general form of the cyclic curves of iron can sketch a cycle with fair accuracy from a knowledge of these principal points.

Reference to the cycles shown in Figs. 32 to 34 will show that different sorts of iron differ greatly in the form of the cycle. The greater the coercive force for a given maximum B the "harder" the iron is said to be. In such alloys as are used for permanent magnets (e.g. Fig. 34) the coercive force is very high and these retain the remanent induction very strongly.

Since the curve is the same below the axis of H as above, it is usual to draw only the upper half. In Fig. 32 will be found three cyclic curves for a specimen of cast steel, the apices of such a family of cyclic curves evidently lie on the reversal curve of the iron. It

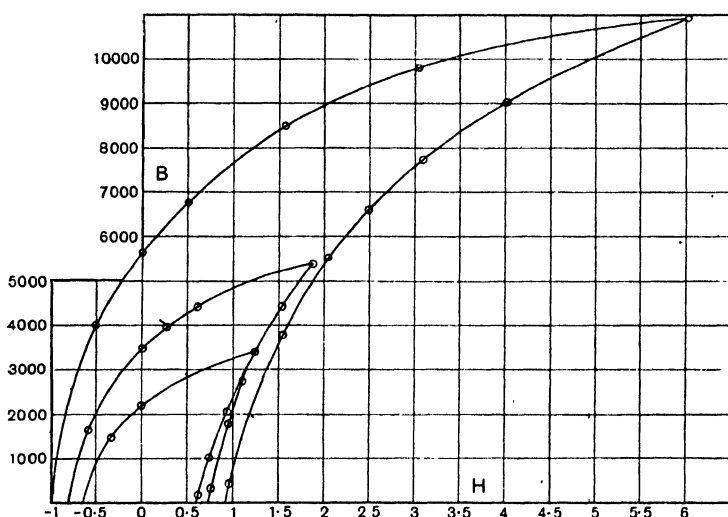

Fig. 32

will be noted that the change of flux always, as it were, "lags behind" the magnetic force; from this circumstance the phenomenon is called Hysteresis, and the curve is often called "the hysteresis cycle." A similar loop connects almost all quantities which are related as are Stress and Strain, in fact H can be looked on as the Stressing agent in magnetism and B as the corresponding Strain, so that non-magnetic substances are strong in resisting magnetic stress while iron is weak. In all such stress-strain loops there is loss of energy which appears as heat, and the same applies here.

MAGNETISM

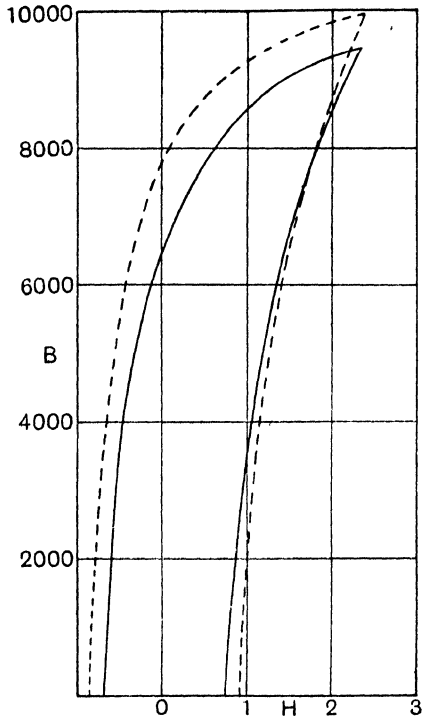

Fig. 33

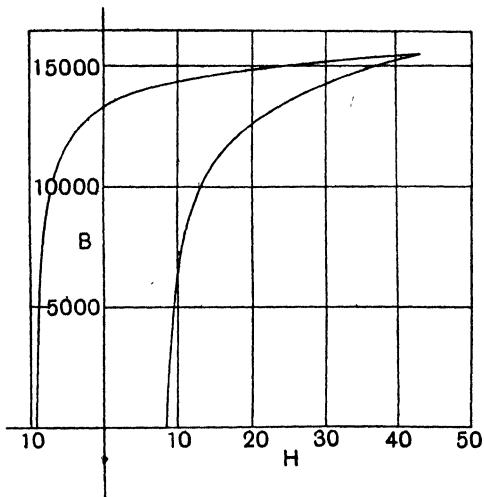

Fig. 34

39. The lost energy. Suppose that the point P in Fig. 30 is moved regularly to and fro so that the H applied to the ring varies periodically with a definite periodic time T , or at the rate of n cycles per second. Let the ring have as before a mean axial length l , and a cross section s , and be wound with N turns, and let the current at any instant be i so that the magnetic force is $H = 4\pi Ni/l$. At that instant there will be an induction B , and consequently a flux Bs and flux-turns numbering BNs . Hence in addition to the pressure required to maintain the current against the resistance of the wire, the source of energy, which is the P.D. between C and P , must supply an extra pressure equal to the E.M.F.

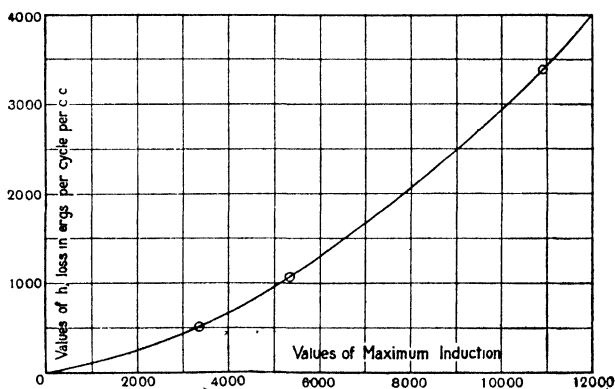

Fig. 35

induced in the winding on the coil, namely $e = \frac{d}{dt}(BNs)$. Hence the extra power demanded at that instant being ei is equal to $\frac{Hl}{4\pi N} Ns \frac{dB}{dt}$ or $\frac{1}{4\pi} lsH \frac{dB}{dt}$. Thus if dW denote the work done in the small time dt , we have $dW = \frac{1}{4\pi} lsHdB$. It follows that the total work drawn from the source in one cycle is $\frac{ls}{4\pi} \int_0^T HdB$ ergs and, since ls is the volume in c.c., the energy lost per c.c. per cycle is $\frac{1}{4\pi} \int_0^T HdB$ ergs. But the integral is evidently the area of the whole cyclic curve, and hence we have, *energy lost per c.c. per cycle in ergs* = $\frac{1}{4\pi}$ (area of cycle). Of course care must be taken

to allow for the very different scales used for H and B . The symbol h will be used to denote the energy lost per c.c. per cycle. In Fig. 35 is given the curve connecting the values of the lost energy h and the maximum induction B for the three cycles shown in Fig. 32. This curve lies between an inclined straight line and a parabola; if the logarithms of corresponding values of h and B are plotted it will be found that they lie on a straight line, showing that the relation is of the form $h = \eta B^\epsilon$, and in the example given the value of ϵ is found to be very nearly 1.6; this empirical formula is due to Steinmetz, and is approximately true over a long range of induction and for many sorts of iron and steel which only differ in the value of η . It is sometimes more convenient to express the loss in watts; if the volume of the iron be v c.c., the periods be n and the appropriate value of the loss per c.c. per cycle be h , we have

$$W = hvn \times 10^{-7} \text{ watts,}$$

or $W = \eta vn B^{1.6} 10^{-7}$ approximately.

40. Force between two surfaces. The following important result can be obtained, giving the attractive force between two equal and oppositely magnetised surfaces close together. Consider a ring filled with air; we have seen that the energy expended for a small change in the induction is given by $\frac{1}{4\pi} H dB$ for a cubic centimeter of the ring. Hence the energy stored from zero value up to any other value of the induction must be $\frac{1}{4\pi} \int_0^B H dB$. But in the case of air the relation between H and B is linear and hence this integral has the value $\frac{1}{4\pi} \int_0^H H dH$, that is $\frac{H^2}{8\pi}$ or $\frac{B^2}{8\pi}$ whichever we choose to use. Suppose now that we have two similar surfaces opposed to one another and a uniform magnetic force between them, as would result from cutting across a magnetised iron ring. In the space between the opposed faces the air will be magnetised and each c.c. will store $B^2/8\pi$ ergs. Let the areas of each surface be A and the distance apart be r , then the energy stored will be $A r B^2/8\pi$ ergs: if the surfaces approach by the small distance dr , the induction being the same, the energy in the space thus filled up has gone, this lost energy has the value $A dr B^2/8\pi$. But the only way it can have been used up is in doing work, and hence if f be the force pulling the surfaces together the work done

is fdr and hence this force is $AB^2/8\pi$. Thus the mechanical force between two such similar surfaces is $B^2/8\pi$ dynes per square centimeter; and provided that the gap is small this is very approximately true in actual cases. This result can be put in a convenient form as follows. Since 8π is nearly 25 and a joule is 10^7 ergs while a litre is 10^3 c.c., the energy stored in joules per litre is $(B/500)^2$.

41. Practical determination of cycle. The method described on p. 46 is known as the "step by step" method, and has given very good results, but it has the disadvantage that no allow-

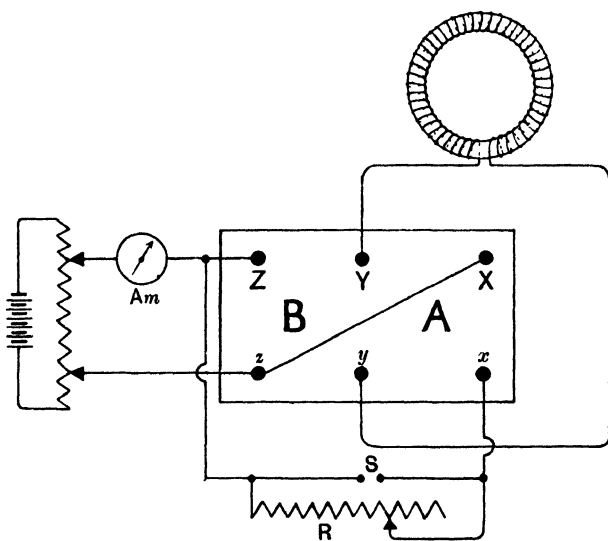

Fig. 36

ance can be made for errors and no observation can be repeated; in a practical test it is essential that any determination can be repeated at will, and this is secured by the following method due to Ewing. An ordinary reversing key is used but is modified as shown in Fig. 36, one of the cross-connecting wires being removed, and replaced by a resistance R (called the cyclic resistance) in parallel with a short circuiting switch S , so that when the latter is in, the key is an ordinary reversing key. The rest of the circuit is the same as in Fig. 21, hence only the primary circuit of the specimen is shown, and the galvanometer is supposed to have been

calibrated by the standard field so that it reads induction changes direct as described on page 38. Similarly the ammeter readings will be supposed to read H directly as is described in the same place. On tracing through the diagram it will be seen that when the copper bridges of the reversing key join the mercury cups X, Y and x, y the current is compelled to pass through R , or across it if short-circuited, this we will call the A position of the key: when the other bridges join Y, Z and y, z , the current passes directly round the coil, this we will call the B position. Suppose that we wish to find the cycle shown in Fig. 37; with the switch S made, a current producing

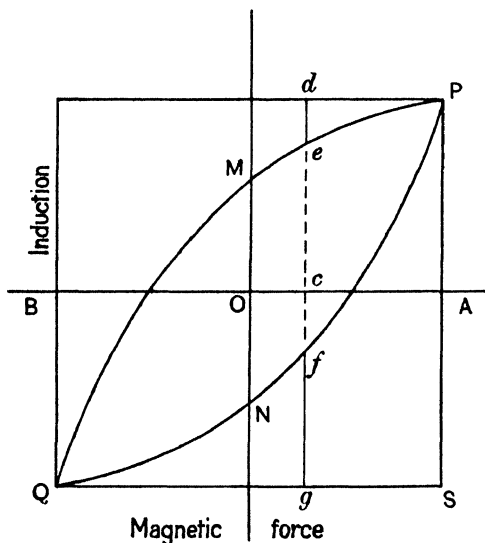

Fig. 37

the maximum H given by OA will flow when the key is in the A position, and an equal and opposite current will flow when the key is in the B position, this being given by OB . If the key be thrown over from A to B the total change of induction will be shown by a fling proportional to this change from the point P to the point Q , that is, to PS . Now let the key be in the A position, press down the galvanometer key, and pull out the switch S ; the current must now pass through the resistance R , and hence the magnetic force suddenly changes from OA to Oc , corresponding to the reduced current. The corresponding change of induction will be shown by a fling giving de . Release the galvanometer key and throw over

CYCLIC CURVE

the reversing one, the cycle is carried to Q : press down the galvanometer key once more, and throw the reversing one back to the A position. The induction will change from the value at Q , namely QB , to that for the magnetic force Oc on the lower branch of the cycle, namely cf ; the amount of the change, namely gf , will be measured by this second fling of the galvanometer. Finally replace S , thus carrying the cycle back to P . It will be seen that by a preliminary adjustment of the resistance R to a set of values from zero to infinity, all possible points on the parts PeM and PfN of the cycle can be obtained: further we can always return to the fixed point P , we can adjust in every case the maximum magnetic force OA , and we can repeat each observation as often as may be desired. Before taking a set of readings for any new value of R it is desirable to reverse the current so as to carry the iron some few times round the cycle in order to establish it quite definitely.

42. Effect of composition, etc. On referring to the reversal curves of different materials given in Figs. 22 to 24 it will be noted that certain alloys, such as the silicon alloy known as "stalloy" have a greater permeability than good iron at moderate inductions; this property is often accompanied by a smaller value of " h ." Thus in Fig. 33 the dotted curve shows a cycle for a pure iron and the full curve one for a silicon alloy, the latter having a value $h = 2000$ while the iron has $h = 2730$. A similar result is found with alloys of aluminium, tin and arsenic; these alloys have also a property of value in that their specific resistance is much higher than that of pure iron. The curve in Fig. 34 is that of a tungsten alloy, and it will be seen that the coercive force is high, hence it has a large value of h . Cyclic curves are also greatly affected by over-strain which causes an increase in the value of h : in some cases this can be largely nullified by judicious annealing. Another effect is that known as "ageing." It is found that certain specimens show an enormous increase in h when exposed for a greater or shorter time to a temperature above the normal. This effect is very marked in pure iron, but the better class sheets now employed, especially the silicon alloys, do not exhibit it to any great degree (see paper 13).

43. Magnetic History, Loops. So far we have considered the magnetising current to be taken through a cycle, always

increasing and diminishing from one maximum to the other. But this need not be the case; for consider a cycle PQ in Fig. 38; we may stop at a and by a suitable manipulation of the position of the sliding point P in Fig. 30 return to P , or we may stop at b , make the little superposed cycle bc on the way to b , and hence cover over the main cycle with any number of these so-called "loops." Each would entail its appropriate loss of energy, and hence it follows that while the value of h for the main cycle is a minimum, we can

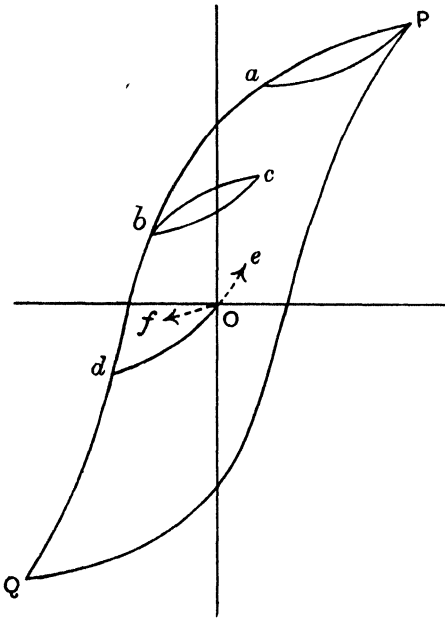

Fig. 38

make it as large as we please by loops on the way from P to Q and back again. Such loops, generally not more than one, are actually formed in certain magnetic apparatus when used with alternating pressures of certain shapes. It is clear that the shape and area of any such loops, even if taken over the same range of H , will differ according to the position on the main cycle at which they occur. Hence the value of h will depend on the previous magnetic treatment to which the iron has been subjected to, that is on its "magnetic history." This is well shown as follows. Suppose we stop at d and

hit off a bit of a loop that just goes through O . To any ordinary test the iron is non-magnetised, but if we start a test, applying H in the positive direction, the curve of B and H will start off in a continuation of dO or as Oe , while if we start with a negative H it will start off as Oj . Thus the same piece of iron would apparently have totally different reversal curves. We must hence have some trustworthy method of making sure that the iron is in a truly neutral state to start with. This is secured by what is termed "demagnetising by reversals," that is by subjecting the iron to a large number of cycles of continuously diminishing amplitude. It is found that if we start off with a current sufficient to carry the iron somewhat above the point of maximum permeability, the corresponding H being in general a little larger than 10, the demagnetisation will be satisfactory, provided we reduce the current slowly and continuously, meanwhile making a large number of reversals. This precaution must always be taken before proceeding to find any magnetic curve.

44. **Magnetic Tester.** The complete determination and reduction of a cyclic curve test is a matter of some time and skill. For commercial purposes a rapid comparison of specimens may be made with the apparatus shown in Fig. 39 and known as Ewing's Hysteresis Tester. The specimens to be tested are generally in the form of strips made up into a little bundle of a definite length and as nearly as possible of a definite section. This bundle is fixed in a carrier which can be rotated, as shown, in the magnetic field due to a pivoted horse-shoe permanent magnet, which produces an approximately definite flux density in all the specimens. We have seen that the power absorbed by the iron is proportional to the speed of rotation, hence the couple that must be applied to rotate the specimen will be practically independent of the speed of rotation and will depend on the loss of energy in the specimen, and on any loss that may occur in the magnet itself, in which a sort of cyclic loop will be produced by the variation of flux caused by the varying position of the specimen. This couple is necessarily mutual and will act on the magnet which will thus tend to turn round. It is pivoted so as to be just stable, and will therefore take up a steady deflection the amount of which will depend on the value of h for the specimen. It is found that if a set of specimens of known h be tested, and the relation between the angle of deviation of the magnet and the value

of h be plotted, the result is a straight line which, however, does not pass through the origin owing to the loss in the magnet itself. The instrument is provided with two standard specimens of known values of h , the deflections produced with these are observed and plotted against the values of h , and the points are joined by a straight line. The unknown specimen is then inserted and the deflection produced is noted. From this and the plotted line the value of h for the specimen is at once determined.

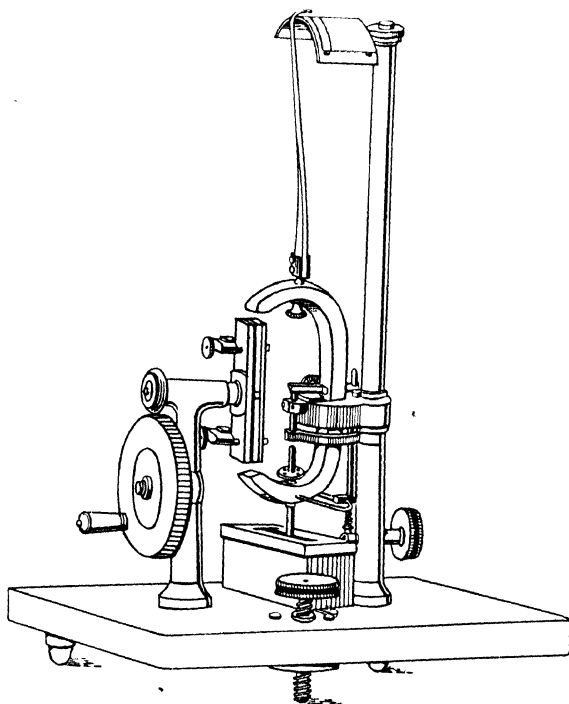

Fig. 39

45. Rotating Hysteresis. The question now arises whether h , the value of the loss per c.c. per cycle, is the same when we carry a fixed piece of iron round a cycle in the manner of a cyclic curve, as when the specimen is rotated as last described.

A certain ring was tested by the former method and gave a curve connecting h and H which is shown in Fig. 40 ("alternating loss"). The same ring was then placed in a carrier which was

placed between the poles of an electromagnet which could be rotated. The resulting couple was measured by fixing a delicate spring control to the axis of the carrier, the strength of the control being measured beforehand. From the known couple thus measured the corresponding h of the iron can be determined at once. The flux can be varied by altering the current round the magnet. The induction is easily found for each current as follows: a search coil is wound round the ring at one point and the ends attached to a calibrated ballistic galvanometer. The ring is placed so that the

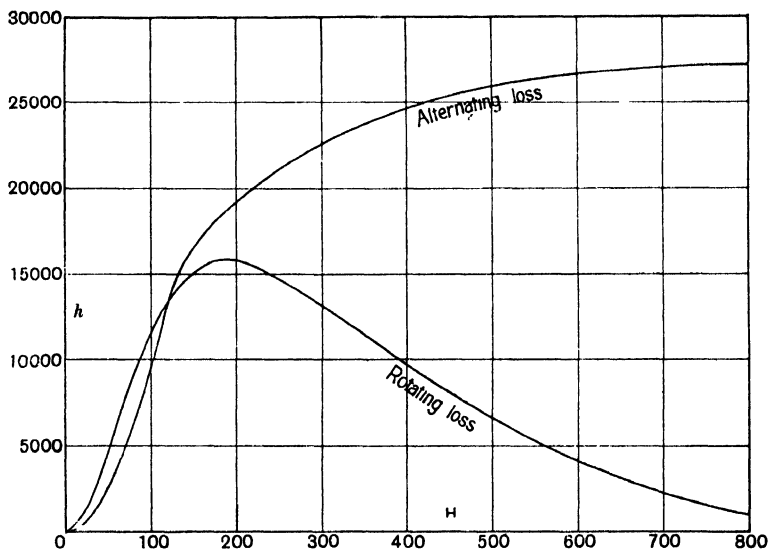

Fig. 40

coil is midway between the poles of the magnet, and is suddenly given half a turn so that the flux is all withdrawn from the ring and reinserted in the opposite direction. From the resulting fling and the section of the ring, the value of B , and hence of H for the known ring, can be found. The curve connecting H and h for this state of things is shown in the second curve. It will be seen that at first there is no great difference between the two curves, but at high values of H the rotating loss begins to fall, and at very high values it is very small indeed. Unfortunately this occurs at values of the magnetic force which cannot be commercially used in dynamos.

It will be noticed in Fig. 40 that the alternating hysteresis at first grows very rapidly with increase of H , but that for values of H above 200 the rate of increase rapidly falls off. This value of H corresponds to the saturation region of the induction referred to on page 42. If the results are plotted in terms of the induction instead of the magnetic force, the sharpness of the change is accentuated, and we have a well marked knee in the curve connecting h and B occurring about the saturation value of the induction. Thus, in a particular sample of iron the hysteretic loss increased in the ordinary way up to an induction of about 20,000, a further increase in induction to 25,000 only raised the loss about 8 per cent., and beyond that value the loss increased but little with the induction. The cause of this phenomenon will be seen later on.

46. Eddy Currents. When the flux through the iron is changing there is another loss per cycle not independent of the cycles per second as is hysteresis, but proportional to them. As nearly all the tests we have hitherto considered involve slow cycles, the results are not affected by this new factor, but we must now consider it.

Let an anchor ring of any metal, magnetic or otherwise, be wound as usual, and let the ends of the coil be attached to the points P and C in Fig. 30. Further, let P be moved to and fro so that the current varies with the time as shown in Fig. 41, the time of one complete

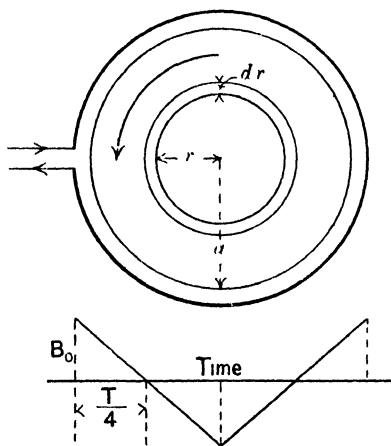

Fig. 41

cycle being T and the number of cycles per second being n . Let the current in the winding be flowing as shown in Fig. 41, and let it be increasing in value. Corresponding to the current at any instant there will be a definite magnetic force, and if we suppose that the metal is non-magnetic, B will vary as the current: hence the flux in the ring will be growing. Consider any concentric circle of radius r ; inside it the flux is growing, and the

outside ring section forms a circuit in which there is a changing flux. Hence round that circuit will be induced an E.M.F. and a current will flow; this is an Eddy current in the metal. The direction of the current must be such as to oppose the change of flux that is taking place, and since the flux is increasing the eddy current must flow in the opposite direction to the main outside current so as to oppose its action as indicated in the figure. When the current outside is diminishing, whatever be its direction, the current inside will flow in the same direction as the outside current so as again to oppose the change of flux. But it will be seen that successive partial sections such as that considered will have different fluxes inside them, and hence will be accompanied by different eddy currents round them. It follows that the net magnetic effect, being that due to the main and the eddy currents, will vary from the centre outwards, and hence at any instant the resulting flux cannot be uniform all over the section: further, the maximum of the flux will not be reached at the same moment for each radius. This effect is called "screening" and is very important, but the full discussion would take us too far. The greater the section and the more rapid the changes of flux, the larger this effect will be. If we are dealing with smallish rings, and not too high a rate of change of the current, the induction will be much more nearly uniform, and we will assume that it is strictly so, and that the maximum value, which we will call B_0 , is attained all over the section at the same instant.

Now consider a centimeter length of the anchor ring, let the external radius of the cross-section be a , and the specific resistance ρ . The annulus between the rings of radii r and $r + dr$ will have the resistance $R = \rho \frac{2\pi r}{dr}$. Inside the ring the flux is $\pi r^2 B$ where B is the induction at the instant. The E.M.F. generated round the annulus, being equal to the rate of change of the flux inside, is given by $e = \pi r^2 \frac{dB}{dt}$. It follows that the power lost in the annulus being e^2/R is given by $dW = \frac{\pi}{2\rho} \left(\frac{dB}{dt}\right)^2 r^3 dr$. Since the induction is changing in the manner shown in the figure, it follows that $\frac{dB}{dt} = \frac{4B_0}{T} = 4B_0 n$, hence $dW = \frac{8\pi}{\rho} B_0^2 n^2 r^3 dr$. In order to find the loss in the whole section of unit axial depth we must integrate this between 0 and a which gives $W = \frac{2\pi}{\rho} a^4 B_0^2 n^2$. But the

volume of the part considered is $\pi a^2 \times l$, hence the loss per c.c. is $\frac{2}{\rho} a^2 B_0^2 n^2$. Thus the eddy current loss per c.c. is proportional to the square of the maximum induction and to the square of the number of cycles per second, but varies inversely as the specific resistance. The latter point explains the advantage possessed by the silicon alloys referred to on page 55.

If some different law of change be assumed a factor different from "2" will be found, but the form of the expression is the same. We might assume that P is moved to and fro with simple harmonic motion by an eccentric; the student should work this case out for himself.

47. Effect of subdivision. When the shape of the section is other than the simple form just considered or a similar simple form, it is impossible to calculate with exactness what will be the eddy current loss. But an important case is that where a given mass of iron is more or less divided up into laminae. Suppose we have a specimen of iron as shown in Fig. 42, and assume a changing flux down it through the section shown. Eddy currents will be produced flowing somewhat as shown by the dotted line. Now slice the iron into n similar laminae as shown below. Manifestly the flux caught by each lamina is $1/n$ th of the whole, and hence the E.M.F. forcing an eddy in the lamina is also $1/n$ th. But the eddy current paths, while having nearly the same length as before, have only $1/n$ th of the cross-

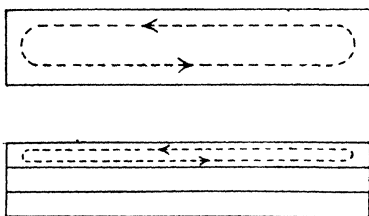

Fig. 42

section, so that the power wasted in the lamina will be $1/n^3$ of the former loss, since the power varies as E^2/R . But the slab is formed of n laminae, thus the effect of laminating it is to reduce the loss in the given mass of iron in the ratio $1/n^2$. This shows the great importance of lamination in reducing eddy current losses.

Other things being equal, for a given flux density the eddy loss will manifestly be inversely as the specific resistance of the metal. The silicon-iron alloys already referred to as having almost the same magnetic properties as a pure iron possess a much higher specific resistance. Hence in these alloys a considerably less degree

of lamination is required to attain the same limit of eddy current loss as compared with ordinary iron or steel sheets of similar magnetic quality.

48. The Induced Voltage Method. An immense amount of ingenuity has been expended in contriving different methods of obtaining the cyclic curve, but the general principles involved are similar to those underlying the ordinary test that has been described. The induced voltage test is, however, different, and it is especially valuable in the case of very large masses of iron such as are found in the cores of large transformers. Suppose we provide the specimen with a secondary which is joined to a dead-beat and sensitive voltmeter, and apply to the primary some apparatus for smoothly changing the current in any desired manner such as that shown in Fig. 30 or some more perfect form. Let a certain current be flowing such as to produce the desired maximum magnetic force, if the current change the corresponding change of flux will produce an E.M.F. which can be read on the voltmeter in the secondary. By skilfully moving the point P we can so alter the current that the reading of this voltmeter is constant, say V , and since the induced E.M.F. is given in volts by

$$N \frac{d\phi}{dt} \div 10^8$$

where ϕ is the flux in the iron and N the turns in the secondary, we have at once

$$Nd\phi/dt = V \times 10^8$$

and therefore, since V is constant,

$$\int \phi = \frac{V}{N} 10^8 t.$$

The curve connecting current and time can be plotted from simultaneous readings of these quantities, and since H and ϕ are proportional to current and time respectively the curve is also a branch of the cyclic curve to scales which are at once known when the dimensions of the iron core, its primary winding, etc., are given. This method is, as said, directly applicable to large masses, where it may take as much as half an hour to go through the whole cycle but it is difficult to use in this simple form for more reasonably sized specimens. By a suitable design of sliding resistance and by

using a potentiometer method for measuring V , Dr Morris and Mr Longford have developed it into a very perfect method of test (see paper 11).

Another method, due to Kapp, is the following. The circuit is connected up as shown in Fig. 43 where S is a low resistance shunt by means of which the initial value of the current can be adjusted, with the help of the main resistance r , so as to give any desired value. V is a sensitive low reading voltmeter, K a well made reversing key, and A a central-zero ammeter. In making the test the current is first adjusted to the desired maximum, at a given moment the key K is thrown over, and then simultaneous time readings of the voltmeter and ammeter are taken. Such a set of readings is given in the following table, to which are added the dimensions of the iron and the number of turns of wire.

T	v	i	iR	e
0	·435	-2·0	-·435	·870
1	·510	0	0	·510
2·5	·506	0·6	·130	·376
4·5	·501	0·8	·174	·327
6·6	·495	1·0	·218	·277
8·5	·473	1·2	·261	·212
9·5	·462	1·4	·304	·158
10·6	·451	1·6	·348	·103
11·6	·446	1·8	·392	·054
15·2	·435	2·0	·435	0

Section of iron = 420 sq. cm.

Volume of iron = 37,000 cu. cm.

Turns of wire = 80.

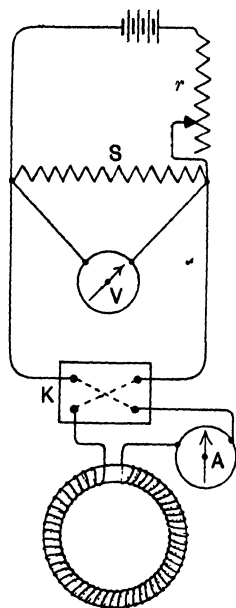

Fig. 43

At any instant of time let the P.D. as read on the voltmeter be v , and the current i , and let R be the resistance of the whole circuit in parallel with S . The value of R is found at once from the initial steady readings of voltmeter and ammeter; in the test considered there were 0·435 volts and 2 ampères. Let the induced E.M.F. at any instant be e . At that instant the applied pressure v will equilibrate the induced E.M.F. e together with the pressure-drop round the circuit, that is iR . We have therefore $v = e + iR$, or $e = v - iR$. We can therefore at once complete the columns for iR and e . In Fig. 44 the curve for time and

current is marked by crosses, and that for time and E.M.F. by small circles. Since $e = N \frac{d\phi}{dt}$ or $\phi = \frac{1}{N} \int_0^t e dt$ we can by step by

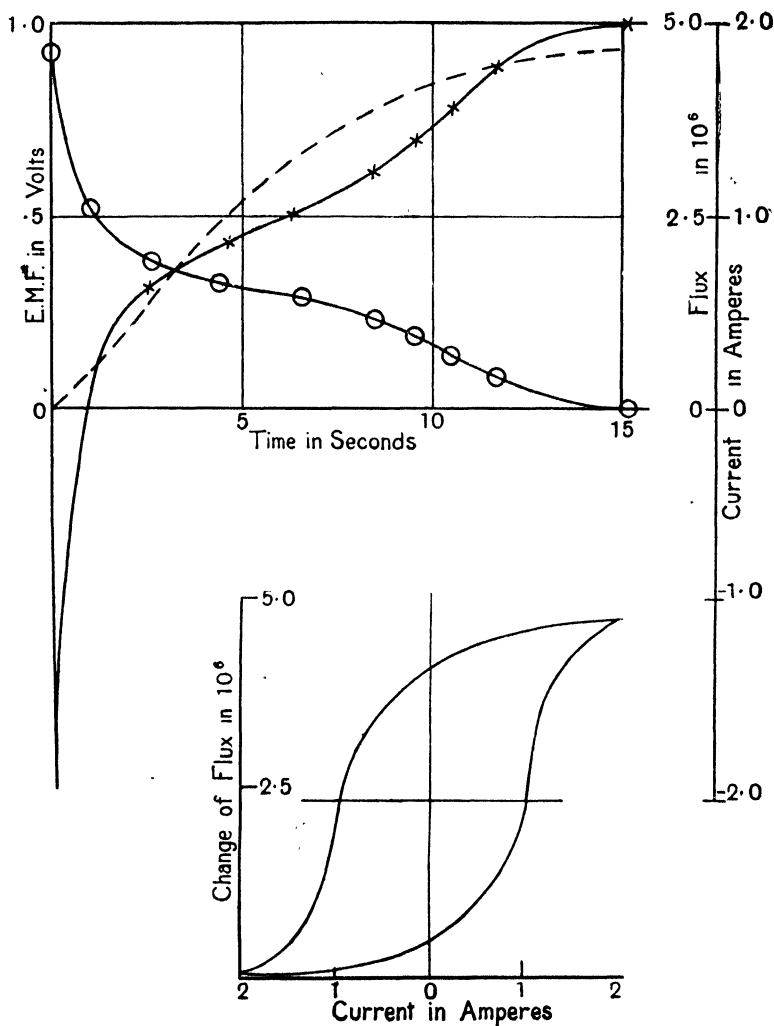

Fig. 44

step integration of the $t-e$ curve determine the value of the flux at any instant and can plot the flux-time curve. This is shown by the dotted line in the figure.

The question of scales is important. In the test considered one inch represented 0.5 volt and 5 seconds, and therefore a square inch represented 2.5 volt-seconds. The paper was divided into tenth-inch squares so that the areas of the $t-e$ curve up to the end of each successive second were easily measured. The area of the whole curve was 1.48 sq. inches. Reckoning in absolute units we see then that the whole change of flux in the period of reversal was

$$1.48 \times 2.5 \times 10^8/80,$$

that is 4.62×10^6 lines. The maximum flux was therefore 2.31×10^6 lines, and since the cross-section of the iron was 420 sq. cm. the maximum induction was 5500. The curve connecting flux and current could be derived at once, and thus the ascending branch of the cyclic curve was plotted as shown in the lower part of the figure.

Again, if s be the cross-section of the iron, l its length, and N the turns on the magnetising coil we have $\phi = Bs$ and $i = \frac{10l}{4\pi N} H$ and therefore $\int id\phi = \frac{10}{N} \left[\frac{sl}{4\pi} \int HdB \right]$. The expression inside the bracket is the total loss in ergs due to the whole mass of iron being taken round the cycle, and thus in the test considered the loss in joules per cycle is $\frac{80}{10} \times 10^{-7} \int id\phi$ or $8 \times 10^{-7} \int id\phi$. The integral was found by counting the small squares in the figure, and its value was 1.5 sq. in. As one inch represented 2.5×10^6 lines and 2 ampères respectively a square inch represented 5×10^6 for the product ϕi . The loss per cycle for the specimen under test was thus 6 joules, and therefore $h = 6 \times 10^7/37,000 = 1620$. This experiment has been modified in many ways, but the principle is the same throughout.

49. The Magnetic Circuit. Up to the present we have been mainly concerned with cases where the induction was uniform all round a ring, and in which as a rule that ring was homogeneous and of constant section. We must now deal with more usual cases where the ring is of different materials along its length; such a collection of different sorts of material through which magnetic flux is passing is called a Magnetic Circuit. Like the ring it is provided with a magnetising coil, and the one factor which is unchanged is that established on page 27, namely that the work done

in carrying a unit pole round a path that passes through the coil is equal to $4\pi NI$ where N is the number of turns on the coil and I the current; this quantity is called the Magnetomotive Force. In our uniform ring the magnetic force H was constant all round and hence the work done in carrying the pole round was the same for each centimeter of the path, but with a core which is non-homogeneous as regards section or material this will no longer be true. But there will be a definite induction at every part of the circuit and hence a corresponding value of H , known when the properties of the material are known, and the work done on carrying the pole round will now be given by $4\pi NI = \int H dl$, where the integral is taken completely round the circuit. In a great many cases a circuit is such that it has definite lengths with definite flux densities in each, and we may write $4\pi NI = \Sigma Hl$. If one part be an air-gap of length λ with an induction B_a in it, we can write

$$4\pi NI = B_o \lambda + \Sigma Hl,$$

the last set of terms referring to the various iron portions. The appropriate value of H for each part must be found from its induction and the B - H curve for its iron.

This form of the equation is of considerable importance. In an ordinary electrical circuit the electromotive force has to balance the demands for potential difference made by the several sections. In the magnetic circuit we see that such a term as Hl is the difference of magnetic potential at the ends of the portion of the circuit under consideration, and again the whole magnetomotive force has to supply the demands of each section for a magnetic P.D. The magnetic P.D. existing between any two points can be found by the method now to be described.

50. Measurement of difference of magnetic potential.

The following ingenious method of measuring this quantity is due to Chattock and has many useful applications. We have seen that the magnetic potential, V , is that quantity whose rate of change in any direction is equal to the magnetic force in that direction, that is $H = dV/dl$. Let V_1 and V_2 be the values of the potential at any two points, and let the points be joined by any path, straight or curved. At any point on that path we have $H = dV/dl$ and hence on integrating along it we have $V_2 - V_1 = \int_1^2 H dl$. We want some physical method of finding the integral. Suppose we take a

solid flexible rod such as a cylinder of rubber, and with great care wind on it a perfectly uniform winding of fine wire so that the turns per cm. are N . If the section of the rod be fairly small the value of the induction at any section will be equal to the value of H existing there, hence the flux-turns through one turn of the wire will be Hs where s is the small constant section. The flux-turns in a length dl will be $HsNdl$, and hence the total flux-turns for the rod when stretched in any way between the two required

points will be $\int_1^2 NsHdl$, that is $Ns(V_2 - V_1)$. If the coil be in circuit with the usual resistance and ballistic galvanometer, and if the magnetic potential be suddenly produced, the flux suddenly sent through the coil will give a fling θ so that

$V_2 - V_1 = \frac{R}{Ns} k\theta$ where R is the total resistance and k the usual

complete ballistic constant. The quantities N and s can be measured directly, but the following method is better. Provide any coil of known turns n carrying a current of known value I in absolute units; push the rod through the coil and bring the ends close together. From page 27 we know that when such a coil is threaded by any closed path the change of magnetic potential along the path is $4\pi nI$. Hence if the current be suddenly made, a fling will result

and if this be θ_s we have $4\pi nI = \frac{R}{Ns} k\theta_s$. If the galvanometer

has been calibrated by a standard field with the same total resistance, we can evidently at once determine the required value of Ns . When we wish only to compare differences of magnetic potential no calibration is necessary, the ratio of the flings with the rod in the two positions will be sufficient. If we wish to determine the value of the magnetic P.D., the rod can be calibrated as actually connected up in the test in the manner given above so that we have

$\frac{V_2 - V_1}{4\pi nI} = \frac{\theta}{\theta_s}$ where θ is the fling with the required P.D. suddenly

established, and θ_s is that with the coil as above mentioned. Clearly we can use reversal of flux in both cases instead of establishment, with the same result.

This apparatus can be used to investigate the distribution of magnetic potential differences in any magnetic circuit. For example, in a dynamo the magnetomotive force is applied by means of windings on the polar limbs, and the total magnetomotive force

can be immediately found from the current taken and the turns in the coils. If we wish to see how much of it is required by any portion of the circuit, say by one of the air-gaps between the polar face and the armature core, we have only to place the flexible rod so that the ends touch on the opposite faces between which the P.D. is required, suddenly reverse the magnetising current on the dynamo, and the test described will at once give the required result, provided the instrument has been calibrated as indicated. We can thus map out the distribution of the magnetic potential for the various portions of the circuit, and find what fraction of the whole applied magnetomotive force is available at any desired place. A description of the method will be found in page 5.

51. Perfect Circuit. Should the flux down a magnetic circuit be the same at every point the inductions will manifestly be given in terms of the relative cross-sections, but if the flux "leaks" or "strays" out we cannot find the required relative inductions. Hence it is best to simplify the problem at first by assuming that the total flux is the same at every section; a circuit having this property is called a Perfect Magnetic circuit. Such a circuit is quite exceptional, but most circuits approximate to the perfect condition. When the circuit is perfect we can proceed as follows. Let ϕ be the constant flux passing, then at any section $B = \phi/s$ and hence, since $B = \mu H$, we have $H = \frac{\phi}{\mu s}$, so that our equation connecting the magnetomotive force with H and l now becomes

$$4\pi NI = \sum \phi \frac{l}{\mu s},$$

that is $4\pi NI = \phi \sum \frac{l}{\mu s}$, since ϕ is constant all round. This equation is, in form, very like that for an electric circuit, the magnetomotive force $4\pi NI$ pushes the flux ϕ round the circuit and the quantity represented by the expression $\frac{l}{\mu s}$ takes the place of Resistance. The resemblance appears even closer if we write the expression in the form $\rho \frac{l}{s}$ where $\rho = \frac{1}{\mu}$ and is called the reluctivity. The quantity $\frac{l}{\mu s}$ or $\rho \frac{l}{s}$ is called the Reluctance of the particular portion of the circuit concerned, its reciprocal is known as the

Permeance. The part of the circuit formed by air has of course a reluctance given by l/s , which is constant, while the reluctance of any other part will depend on the flux in the circuit.

52. Position of coil. In all our rings the primary magnetising coil was wound uniformly over the core, but in practical forms of circuit this is rarely possible, there is thus, at some point, a comparatively sudden discontinuity in the magnetic force as applied by the coil; with a definite current the magnetomotive force is the same however the coil is wound. It might be thought that the flux would also suffer considerable discontinuity, but this is not so, it is fairly uniform in spite of the discontinuity of the coil. At present this must be taken as a fact, but it will be considered later on.

53. A cut ring. As a simple example suppose that one of our anchor rings has a small transverse cut made in it, the windings and sizes being unaltered, let this slit be very narrow and have the length λ so that the iron's length is $(l - \lambda)$. The equation of the magnetic circuit at once takes the form $4\pi NI = \phi \left(\frac{l - \lambda}{\mu s} + \frac{\lambda}{s} \right)$ which can equally well be written $4\pi NI = H(l - \lambda) + B\lambda$ in consonance with our first method (Section 49). This result can be expressed in a somewhat different phraseology which is often very useful. Suppose that the ring were given us to test with the slit already in it, and that we wish to find the true B - H curve for the iron only. All we can read is the current round the coil and the induction as given by the ballistic flings. But we evidently have

$$4\pi NI/l = H + \frac{\lambda}{l}(B - H)$$

or since we know that H is small compared with B we have

$$4\pi NI/l = H + \frac{\lambda}{l}B.$$

The expression $4\pi NI/l$ may be looked on as the value of the magnetic force "applied" to the whole circuit, and may be written H_a . Hence we have $H = H_a - \frac{\lambda}{l}B$, so that if we subtract from the measured value of the magnetic force the fraction λ/l of the induction, we will have the true value of H and can plot it against B

and thus get the desired curve. This may also be regarded as follows; suppose we actually plot the values of H_a and B and then "shear" this curve backwards through an angle whose tangent, properly interpreted on the scales of H and B , is λ/l , the resulting curve is the true $B-H$ one. If this process is applied to a cyclic curve it manifestly leaves the area unaltered, and this fact is made use of in some methods of determining the loss per c.c. per cycle, in which straight strips are used instead of some form of ring: the preparation and test is thus simplified, but it will be seen that, for a desired induction, considerably larger currents must be used.

54. Self-Demagnetising Force. It thus follows that the split ring demands, at every value of the induction, a larger magnetic force than the uncut ring. The only difference between the two lies in the fact that we have brought into existence two poles at the ends; these poles themselves produce magnetic forces everywhere round the ring, the forces acting in a direction opposite to that impressed by the coil. Thus the latter has to provide for the annulment of this new magnetic force as well as to produce that really required by the iron. Whenever such free distributions of flux exist a similar effect is produced, but it is only in specially simple cases like the present that the demagnetising force can be calculated, nevertheless in every case a similar form of expression can be found, although the factor represented here by λ/l (the demagnetising factor) is different in each case.

55. The Double Yoke Method. It often happens that we require to test specimens which are only obtainable in the form of rods. In such cases the ends of two similar rods are passed through holes drilled in two short iron cross-bars or yokes and there clamped, being surrounded by magnetising coils and secondary windings. Two such sets of coils are provided, one is for convenience made 4π cm. long, the other 2π cm. long, and the latter is wound with half the turns of the former, the secondary coils being the same in number on each. The primary turns are usually 400 and 200 since these numbers give convenient values of H with the ammeters usually available. Thus in both cases the value of H , corresponding to a current of I ampères, is evidently $40I$. Two determinations of the reversal curve are taken, one with the long coils the other with the short ones and these are plotted. Neither is the true $B-H$ curve

for the bars since some of the magnetising effect of the coils is absorbed by the two yokes, but we can readily show that if we shear back the curve for the long pair by the difference between the two curves at each point, the result is the true $B-H$ curve for the rods alone. For suppose that some definite induction, B , is present in the rods whether long or short and that the magnetic force required for this induction is H_1 , with long rods and coils, and H_2 , with short rods and coils. Let l be the length of the long rods between the yokes. Since the same yokes are used in both cases, and at the same induction, the reluctance of the yokes will be the same though unknown; let its value be R . If H be the true value of the magnetic force required by the long rods for the existing induction the corresponding magnetomotive force is $2Hl$, while that applied by the long coils is $2I_1l$ and that required by the yokes is aRB where a is a constant. We therefore have $2I_1l = 2Hl + aRB$ for the long coils and similarly $I_2l = Hl + aRB$ for the short coils. Hence we have $2I_1 - 2H = I_2 - H$ or $H = I_1 - (I_2 - I_1)$, that is the true curve is derived from the long rod curve by shearing the latter back through a distance equal to the difference between the long rod and short rod curves for each particular value of the induction.

56. The Magnetic Bridge. Another example is afforded by Ewing's magnetic bridge, shown in Fig. 45, where again we have the double yoke and two equal rods or bars. One bar, whose $B-H$ curve has previously been determined, is used as a standard of comparison, the other is the bar under test. Each yoke carries a long horn and between the tips of the horns a small compass needle is pivoted. The bars are to be magnetised so as to have equal concurrent inductions passing in each; if these are unequal the difference will find its way from yoke to yoke through the horns and the compass needle will be affected. The standard bar is wound so that a current of I ampères in its coils gives a magnetic force of $40I$. The winding on the bar under test is in series with that on the standard bar and consists of a number of coils in series which can be cut in or out of the circuit by the switches shown in the figure. The switches are double ended so that the act of cutting out a magnetising coil automatically introduces into the circuit a dead resistance of equal amount, thus the total resistance of the circuit remains constant.

In making the test a current is applied sufficient to produce the desired induction in the standard bar, and the turns on the other are varied till the compass is unaffected by reversal of the current. At each adjustment of the turns the current is reversed several times to get the flux into a steady state. From the ammeter reading the value of the H on the standard is known, and from the curve of that standard we find the B . This must also be the B in the other bar, and the H acting at that B is known at once from the ratio of the turns on the tested bar to those on the standard.

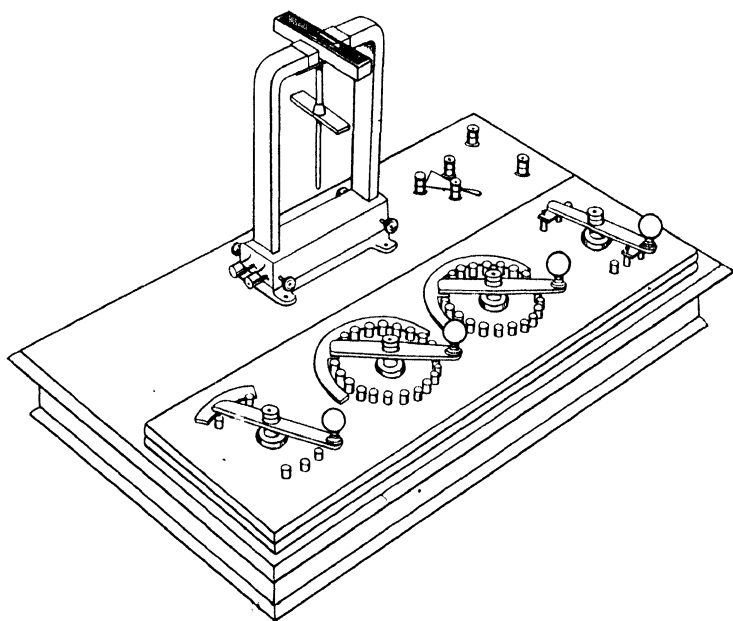

Fig. 45

There are many other methods of testing based on the principle of the magnetic circuit, for example Picou's compensation method, the Permeability meter (paper 8), etc.

57. Stray Flux. We must now turn to the imperfect circuit, that is, one in which flux strays out from various points. Consider the simple case in Fig. 46. The main flux we are considering is that in the iron ring, but since air is not a magnetic insulator, some will leak out across the air and return to the circuit further round. A

flux which thus leaves the main iron circuit is called a "stray" or "leakage flux." In nearly all cases such fluxes take their paths through air or other non-magnetic substances, and we must briefly consider certain properties of these fluxes.

58. Refraction of the Flux. Let the interface between two media be the line XY , Fig. 47, and suppose a flux is crossing as shown by the arrow heads. In all practical cases the direction of B and H coincide. Let their values and their directions, relative to the normal to the interface, be as indicated. As regards the inductions, which are measured by the number of lines of force crossing unit areas held perpendicularly to the directions shown, the resolved components reckoned normally to the interface must be

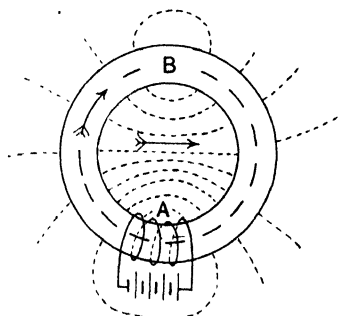

Fig. 46

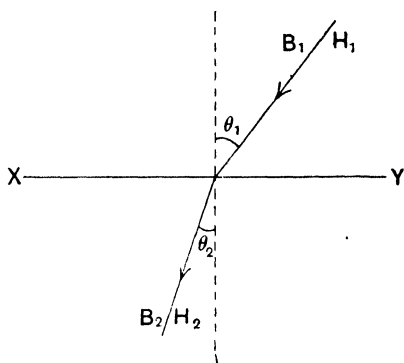

Fig. 47

equal, and hence $B_1 \cos \theta_1 = B_2 \cos \theta_2$. As regards the magnetic forces, there must be no tangential force tending to cause flux along the interface, so that $H_1 \sin \theta_1 = H_2 \sin \theta_2$. Hence we have $\tan \theta_2 : \tan \theta_1 :: \mu_2 : \mu_1$. If we imagine that the flux is leaking from iron, when the angle of incidence at the surface is θ_i , into air in which the angle of emergence is θ_a we have $\tan \theta_i = \mu \tan \theta_a$. The permeability, μ , is always a large number compared with unity, hence while θ_i ranges from zero to nearly 90° , $\tan \theta_a$ will remain quite small, that is the leaking flux is always practically at right angles to the surface of emergence, no matter what may be the direction of the main flux from which it leaks.

A second point is as follows: leakage or stray paths are usually so complex that it is only in the simplest cases, or by virtue of

simplifying assumptions, that the reluctance can be calculated, but since they are air paths, the leakage reluctance of any definite magnetic circuit is nearly constant whatever be the distribution of the flux from which the leakage is taking place. It also follows that the value of the stray flux itself is always proportional to the magnetomotive force or difference of magnetic potential that is urging it. This consideration simplifies very much the consideration of the stray flux.

59. Dispersion Coefficient. In general the flux has to be utilised at a part of the circuit distant from the magnetising coil, thus in Fig. 46 it is impressed by the coil at *A* but is, say, required at *B*. For example in a dynamo, *A* would be the field-magnet coil, while *B* would be the armature core. The flux at *A* must be greater than at *B* and the ratio is called the Coefficient of Dispersion. It can be readily measured in an actual circuit by placing secondary coils at *A* and *B* and taking the ratio of the deflections observed on a ballistic galvanometer when the main current is reversed; this ratio is usually denoted by the letter "*q*." Definite positions for comparison having been selected, the value of *q* will depend on many circumstances. For example, the reluctance of the iron circuit from which the stray flux is leaking will diminish as the flux is increased from zero up to the point where the permeability is a maximum, and will thereafter continuously increase. But to a first degree of approximation we have seen that the reluctance of the stray path is constant, and since it is acted on by the same magnetomotive force as the main flux, *q* will at first diminish and then increase. But the effect is even more complicated; firstly, owing to the continuing leakage along the circuit, the maximum permeability cannot usually be attained simultaneously all along; secondly, concomitantly with the variations of permeability of the iron, the refraction of the flux will alter and hence the form of the stray flux will not be strictly constant as we provisionally assumed. In fact the predetermination of stray flux can only be an approximation, and it is usually estimated from a knowledge of its value in each case obtained by previous experience combined with the use of certain empirical rules which will be found in works on design.

The equation of the magnetic circuit can be modified to suit the particular case. For example, in a dynamo the flux is required

at the air-gaps and is usually impressed elsewhere. Suppose that ϕ is the flux required, and that the coefficient of dispersion has been found to be q , let the reluctance of the core of the armature be R_a that of the air-gaps R_g and that of the main field, bearing the coils, be R_f , in terms of the usual constants we can then conveniently write $4\pi IT = \phi R_a + \phi R_g + q\phi R_f = \phi (R_a + R_g + qR_f)$ and thus treat the imperfect circuit as if it were perfect. Of course the value of q depends on that of the flux required.

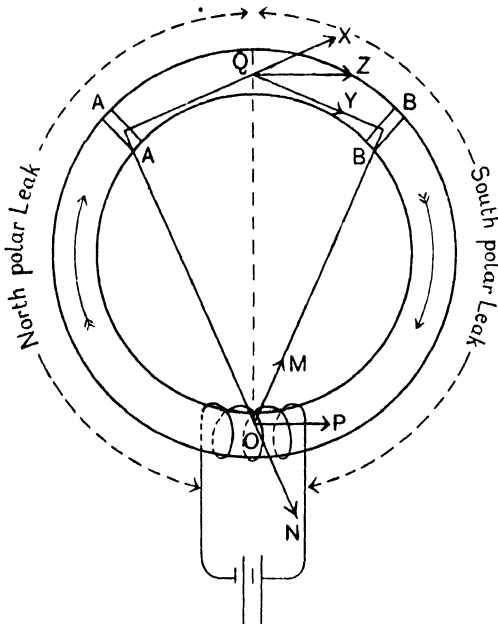

Fig. 48

60. Equalising effect of Leakage. It has already been stated that although the magnetising coil on a ring may be wound on only a small part of it, thus producing a very discontinuous distribution of magnetic force, the resulting induction is very nearly constant all round the ring; this result is due to the effect of the leakages. Consider the ring shown in Fig. 48. With the main flux flowing as shown by the arrows on the core the part OAQ will become coated with north magnetism owing to the leak, and the other half OBQ with south magnetism. Consider two little bits of the ring as at AA and BB equidistant from O or Q , also consider a

north pole at O , it will be repelled by AA along ON and attracted by BB along OM , hence the resultant force will be along OP or in the opposite direction to the magnetic force produced by the coil. Again if we consider the point Q , the force on a north pole there due to AA will be along QX and due to BB along QY , hence the resultant force will be along QZ , that is will tend to help the flux along. Thus the general effect of the leakages is to oppose the main coil and to help the flux round where no coil exists. The leakages so adjust themselves as to keep the flux nearly constant.

61. The Intensity of Magnetisation. When a ring is magnetised to the induction B by a magnetic force H , every elementary portion of the ring, if considered by itself, is a small magnet and hence will possess magnetic moment. Suppose we isolate in imagination a cubic centimeter of the ring, two faces of the cube being perpendicular to the direction of the flux. Such a cube will have a certain magnetic moment which would define its magnetic state just as well as does the induction. This magnetic moment of the cubic centimeter is called the Intensity of Magnetisation of the iron. If it were possible to remove the cube without altering its state (which cannot be done since such removal would at once bring into play the self-demagnetising effect of the poles), it would possess a definite pole strength which would have the same value as the magnetic moment; this quantity is designated by the letter I . Although we cannot isolate the little cube we can endow the ring with poles, as we have seen, by cutting a narrow slit across it. The faces of the slit become poles, and if the area of each be s square centimeters, the pole strength will manifestly be Is . Further, since the flux from a pole of strength m is $4\pi m$, the flux from this pole will be $4\pi Is$, or per square centimeter it will be $4\pi I$. Hence, however the existing state of magnetism be produced, this flux will be present. Further, if the magnetism is due to a surrounding coil which produces a magnetic force H , there will be a flux of the value H per square centimeter even though no iron were present, hence when the two co-exist both fluxes will be present. But the total flux per square centimeter is the induction B and hence we have $B = 4\pi I + H$. Further, if we denote the ratio of the new quantity I to H by the letter k we at once have the relation $\mu = 4\pi k + 1$. This quantity is called the Susceptibility, so that we can express the results given on page 38 as follows: magnetic substances have

a positive susceptibility, for non-magnetic substances the susceptibility is zero, and for diamagnetic substances it is negative. It may be noted that the fact of the existence of a saturation value of the iron referred to on page 45 can be expressed by saying that the Intensity attains a limiting constant value.

62. Ewing's Molecular Theory. Any theory of magnetism must explain at least the following effects, (1) the existence of hysteresis, remanent magnetism and coercive force, (2) a saturation condition, (3) the absence of hysteresis on rotation in strong fields. Such a theory has been given by Ewing, and it consists in supposing that the only forces acting on the molecules are those due to their natural mutual magnetic attractions. Consider the simplest possible case, that of a pair of little magnets mounted as shown in Fig. 49.

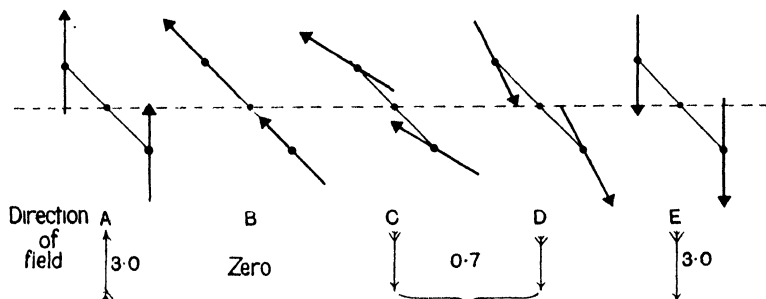

Fig. 49

These were placed in a coil through which could be sent a current, producing a magnetic force in the direction shown, and were mounted so that the line joining the pivots made an angle of 45° with the axis of the coil. The position taken up with zero current is as shown at *B*. When a current of 3 ampères passed round the coil, both magnets were pulled practically into line with the axis of the coil so that the magnetic moment of the pair resolved along that axis was the largest possible, and was practically unaltered however much the current was increased. Position *A* thus gives a "saturation" value of the magnetic moment corresponding to a constant maximum value of the intensity of magnetisation. The current was slowly diminished to zero, and the pair took up the normal position, *B*. The direction of the current was reversed, and while it was slowly increased in the new direction, the magnets

moved slowly to the position shown at *C*, reaching that position when the currents had reached a definite value. On the very smallest increase of current above this value the magnets swung round and oscillated to and fro till they finally came to rest in the position shown at *D*, the pivot friction dissipating the energy: this corresponds to the hysteretic loss. Finally on continuing the increase of the current to 3 ampères, the position shown at *E* was attained. By further reversals of the current the magnets may be taken round the complete cycle. Now the effective magnetic moment along the axis will be proportional to the cosine of the angle made with the axis, and can be plotted as shown in Fig. 50; this has a striking resemblance to a hysteresis curve.

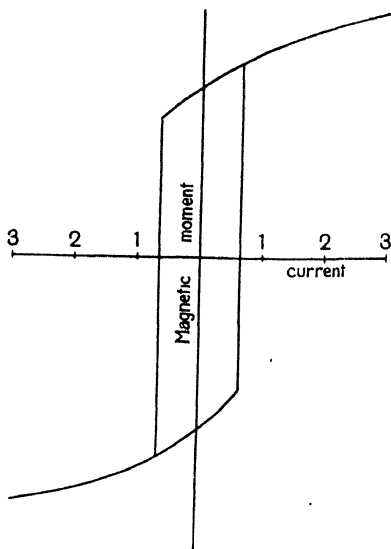

Fig. 50

When the largest current is flowing the pair can be rotated about the common axis and the magnets will continue to point steadily along the axis without breaking apart and oscillating, showing the absence of hysteresis in strong fields.

Such a curve will exist for all pairs having the same inclination of the axis to that of the coil, namely 45° . On the average half such pairs will have their axes as shown, the other half will have their axes at right angles to the axis of the first set, and hence the assumption that we can take the resultant magnetic moment along the coil's axis is correct. Again, there will be all possible pairs with all possible angles between the line joining the pivots and the coil's axis and for each there will exist a curve like that in Fig. 50 but different in form. Further, when account is taken of the action of the pairs on one another, it will be seen that the sharp angles of Fig. 50 will be rounded off, and a much nearer approach to a true cycle will be obtained. In fact, if a large number of little magnets be arranged to represent a bar, and if

the magnetic moment be measured by a magnetometer and plotted against the current producing the magnetic field in a surrounding coil, the cyclic curve thus obtained will be found to be indistinguishable from that of a piece of iron. Such an arrangement will even give the more minute effects in iron such as loops, etc.

63. Tests with alternating currents. Some of the most useful tests of magnetic qualities are best made with alternating currents. Let the contact *P* in Fig. 30 be constrained to move to and fro in such a manner (for example by an eccentric and connecting rod) as to cause the pressure between *P* and *C* to vary according to the ordinates of a curve of sines or cosines as shown by the fine line in Fig. 51. The quantities fixing this curve will be

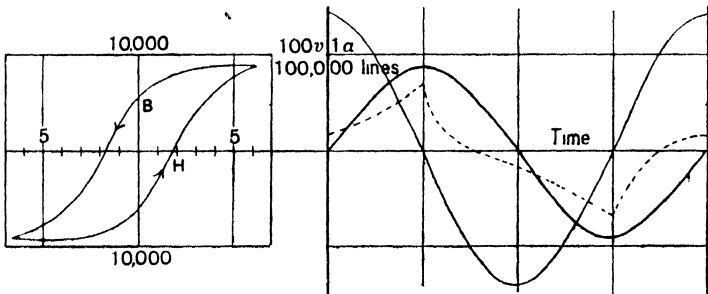

Fig. 51

two, the maximum value of the pressure which we will call *E*, and the periodic time *T*, which can be just as well specified by its reciprocal *n*, the number of cycles per second, that is the frequency. The equation giving any ordinate of the curve is then manifestly $e = E \cos \frac{2\pi}{T} t$, since the maximum will occur at $t = 0$ and $t = T/2$ and the zero at $t = \frac{1}{4}T$ and $t = \frac{3}{4}T$. If we write $\omega = 2\pi n$ this becomes $e = E \cos \omega t$. This method of producing a sinusoidal E.M.F. is very cumbrous, and a more direct one is to be preferred. The required E.M.F. will be given by a coil turning in a uniform field and provided with two end rings so that the current can be readily collected; a practical form of this is secured as we have already seen (p. 33) by slipping two insulated rings over part of the commutator of an ordinary motor and connecting the rings to opposite bars of the commutator. If the motor is run in the ordinary way, the

maximum pressure between the rings will be equal to the brush pressure, and the frequency can be found at once from the R.P.S. of the armature. Suppose that this pressure is applied to a wound ring such as we have previously considered, and let us for definiteness consider actual figures, and take the section as 10 sq. cm., the mean radius as 10 cm., and the total turns as 500. It is proposed to carry the iron round the cycle shown in the figure. The winding will be supposed to have a very low ohmic resistance as is always the case in these tests. It follows that the only E.M.F. which the applied pressure has to encounter is that due to the rate of change of the flux in the coil. If this flux has the value ϕ , at any moment the E.M.F. induced in the coil is, as we have seen, $-Nd\phi/dt$ and hence the pressure that must be applied must be the exact opposite of this or $e = Nd\phi/dt$. The curves of E.M.F. and of flux are thus linked together; if the shape of the one is given, that of the other follows. If then the flux curve be a sine curve, as shown by the thick line in the figure, the flux turns having a maximum value equal to $N\Phi$, the value of the flux turns at any moment is given by $N\Phi \sin \omega t$ and under these circumstances the E.M.F. produced, or rather the P.D. demanded, will be $e = N\Phi\omega \cos \omega t$ or $e = E \cos \omega t$, and the maximum P.D. is $E = N\Phi\omega$. It follows that the P.D. necessary to cause the desired flux to pulse to and fro can be found at once. In the present case we have $\Phi = 90,000$ since the maximum B is 9000 and the section is 10 sq. cm., and since the turns number 500 the maximum flux turns are 45×10^6 . Suppose now that the cycle is being run through 50 times per second, we then have $\omega = 2\pi n = 100\pi$ and the maximum E.M.F. will be $45\pi \times 10^8$ in absolute units. Since a volt is 10^8 absolute units, this means that we must adjust the pressure to have the maximum value 45π volts.

We have already seen that instantaneous values of alternating quantities cannot be directly measured, but that the mean square of such quantities can be measured by instruments in which the instantaneous values of the forces acting depend on the square of the quantity; we found that in this way we could use the force between the coils of a dynamometer to measure the mean square of an alternating current. When pressures are to be measured it is more convenient to use other effects, depending on the square of the pressure, such as the attraction between the plates of a condenser. The maximum value of any such simple harmonic quantity

can be readily deduced from the observed value of the square root of the mean square, that is of the "virtual" value. For since $\sin^2 \theta + \cos^2 \theta = 1$, and since the mean value of $\sin^2 \theta$ and $\cos^2 \theta$ over a complete period must be the same, the mean value of each must be $\frac{1}{2}$. We see then that if \mathcal{E} be the virtual value of a sine p.d. as actually measured, the value of the corresponding maximum will be $E = \sqrt{2}\mathcal{E}$. When the p.d. is not represented by a sine curve the ratio of the maximum p.d. to the voltmeter reading will not equal $\sqrt{2}$; such cases will be considered later.

We have seen that when the curve of pressure and flux are sinusoidal, the maximum value of the flux turns being $N\Phi$, the maximum value of the p.d. is $N\Phi\omega 10^{-8}$ volts. Also if B be the maximum induction and s the cross-sectional area of the ring $Bs = \Phi$ so that if \mathcal{E} be the voltmeter reading $\sqrt{2}\mathcal{E} = NBs\omega 10^{-8}$ that is $B = \frac{\sqrt{2}\mathcal{E}10^8}{Ns2\pi n}$, since $\omega = 2\pi n$. This is the usual method of finding the induction in these experiments.

Again we know that the instantaneous value of the magnetic force H is $\frac{4\pi Ni}{10 l}$ where i is the instantaneous value of the current in ampères and l the mean length along the axis. In the example we are considering $l = 20\pi$ and $N = 500$, so that $H = 10i$, and we may now trace the curve connecting current and time, by means of the cyclic curve for the ring as drawn in the figure. At any point on the time axis note the value of the induction, transfer this to the cyclic curve, observing the direction in which the cycle is described, and thus find the corresponding value of H and hence the value of i which is $H/10$. An ordinate representing the value of i to a current scale can now be erected on the time base, and thus the current-time curve can then be plotted. Four points on the curve, namely those which correspond to the points on which the cyclic curve cuts one or other of the axes, can be plotted at once. The dotted line in Fig. 51 shows the current curve determined in this way. The curve differs widely from a sine curve and hence we cannot derive the maximum value of the current, or of the magnetic force, from the virtual value as given by an ammeter reading, but it is a remarkable fact that for induction up to about 11,000 the value thus derived does not differ much from the true value.

But a more important quantity to be measured in the experiment is the loss of energy. We have seen that a wattmeter can be

used to measure the mean value of the power when both current and pressure are alternating, hence if the winding of the ring be connected up in the usual manner to a wattmeter, we can at once find the mean power from the readings of the instrument. But as

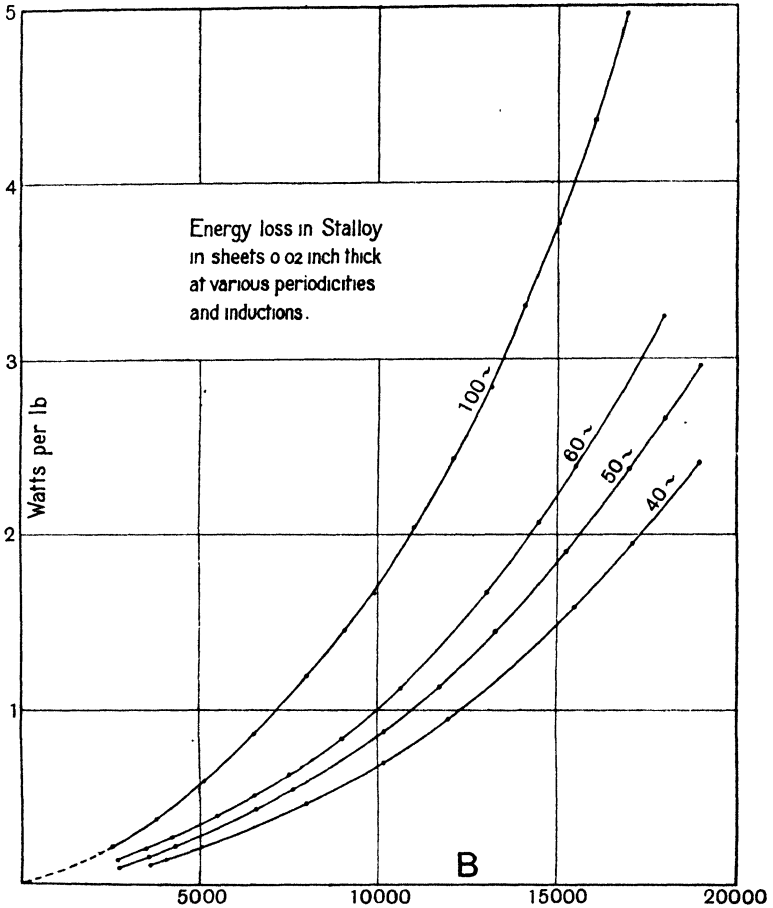

Fig. 52

we know the periods, n , and the volume of the iron, v , we can at once derive the value of h as given on page 52, assuming that the eddy current loss is kept low. For purposes of practical calculation it is usually more convenient to express the loss in watts at known periods, very often a standard periodicity of 50,

than by the ergs per c.c. per cycle. Further the volume is more usefully given indirectly by the weight, and since the specific gravity of all the kinds of iron and steel used is very nearly the same, this is a legitimate method. A series of curves expressing the relation in watts per lb. is given in Fig. 52.

We see, then, that the important relation between the loss of energy and the induction can be found directly without the trouble of determining a set of cycles and reducing the results, and hence the alternating current method is almost always used for investigating this relation. The relation between B and H is, however, best found by one of the methods previously considered.

64. Testing Strip Specimens. Yet another simplification is possible. The preparation of a ring specimen, even in the form of a square, is a troublesome matter. On the other hand if we use a strip of the metal, we cannot, even if we place it at the centre of a long solenoid, produce a uniform induction in it; the induction will be a maximum at the middle of the strip and will diminish towards its ends. Further in measuring the power, by the wattmeter method, the shunt coil will be subjected to a pressure depending on the space-average value of the flux in the iron and not on its maximum value. This difficulty is got over as follows. A small secondary coil is wound just round the middle of the bar and the pressure across this is used both in the shunt coil of the wattmeter in measuring the power, and on the voltmeter from whose reading we deduce the value of the induction. In the middle part of the strip the flux will be practically uniform and the wattmeter will measure the power taken by that part of the iron, while the pressure measured by the voltmeter will be that due to the uniform induction caught by the small coil. The volume of iron concerned, namely that of the part of the strip surrounded by the coil, can be at once calculated from the axial length of the coil and the cross-section of the strip. Thus we can still measure the power lost per c.c. at a known maximum induction.

The magnetic force in the iron must also be considered. In a straight bar there exists a self-demagnetising effect which is proportional to the induction attained, so that if H_a be the magnetic force applied by the coil and H the actual magnetic force demanded at the mid-section of the iron by the induction B we have

$$H_a = H + \lambda B.$$

The hysteretic loss is given by $\frac{1}{4\pi} \int HdB = \frac{1}{4\pi} \left(\int H_a dB - \lambda \int BdB \right)$ and clearly the last integral, taken round the cycle, must be zero. Hence the fact that a strip is used makes no difference in the measured energy loss at the mid-section, but it does mean that a larger current must be used in the coil to force the induction up to any desired value.

65. Further consideration of eddy loss. We saw on page 52 that the value of the loss in ergs per c.c. per cycle is very nearly given by the expression $h = \eta B^\epsilon$ where η depends solely on the quality of the iron, and ϵ is about 1.6 for a fairly considerable range of B , although it has values differing from 1.6 over different ranges if we retain the same value of η . Hence as regards the loss in watts per unit volume at frequency n we can write this in the form $W = \alpha n B^{1.6}$ where α depends on the quality of the iron and the unit of volume only. Again on page 62 we saw that for a given method of variation of the flux the loss in eddy currents could be written in the form $kn^2 B^2$ where k depends on the unit of volume, the degree of lamination and on the resistivity of the iron. It will be found convenient to include in the expression for eddy loss a factor which will take account of the manner in which the flux varies. The hysteretic loss does not depend on this, but solely on the maximum B , but we saw that the eddy current loss depends essentially on the mode of variation of the flux.

66. The Form Factor. If the induction over the section of a specimen of iron be uniform, which we saw was merely a question of reasonable lamination, it is evident that the flux caught by any definite little section of the iron bears a constant ratio to the whole flux passing at any given instant. But the E.M.F. producing an eddy current in that element is proportional to the rate of change of the flux it catches, and is hence also proportional to the rate of change of the whole flux down the section, while the latter is clearly proportional to the E.M.F. induced in the surrounding winding. Further the mean rate of loss of energy in the element is proportional to the mean of the squares of the E.M.F.'s acting during a cycle, or to the mean of the squares of the E.M.F. induced in the winding round the whole thing. But the latter is by definition \mathcal{E}^2 where \mathcal{E} is the virtual value of the induced E.M.F. in the winding as

read on a suitable voltmeter. Hence the essential fact about the eddy current loss is that it is always proportional to the square of the virtual induced E.M.F., but is only indirectly connected with the maximum induction; the relation between the two depending on how the flux changes with time. Thus we should strictly speaking write the eddy loss in the form $k\mathcal{E}^2$. But we wish to express it in terms of the maximum induction as is done with the hysteretic loss; this can be done as follows. Whatever be the shape of the curve by which the induction changes from a maximum to the opposite maximum, provided those maxima be constant, the mean change of induction is from $+B$ to $-B$ in the time $\frac{T}{2}$ or $\frac{1}{2n}$. Thus, whatever be the form of the flux-time curve, the mean E.M.F. being equal to $(4BsNn)$ will be a measure of the maximum induction. But for every form of curve the ratio of the virtual E.M.F. and the mean E.M.F. will be definite. The factor f representing this ratio is called the "Form Factor." It follows that since the eddy loss is proportional to \mathcal{E}^2 , we can write it in the form $\beta n^2 f^2 B^2$, thus separating the factor f which depends on the way in which the flux changes, from the factor β which depends solely on the physical nature of the core. The complete expression for the total loss in a unit volume of iron is hence

$$W = anB^4 + \beta f^2 n^2 B^2.$$

It is only for known forms of the pressure curve that the value of f can be predetermined. Thus, if the curve be perfectly square or rectangular in form, its value must be unity, for a sine curve, since the maximum value is $\sqrt{2}$ times the virtual, and $\pi/2$ times the mean, the ratio of virtual to mean is $\frac{\pi}{2\sqrt{2}}$ that is 1.11. When the factor is not known, we must devise a method of measuring it. We can always find the virtual value of the pressure by an appropriate voltmeter, it follows that if we can devise a method of finding the mean E.M.F. we can deduce f ; this can be done as follows. It will be recalled that we supposed that the current was being supplied by the armature of a motor to the commutator of which were attached two slip rings. Let a disc of ebonite be keyed to the shaft and fix on the circumference of the disc two metal bands which almost meet, each band covering very nearly half the circumference. Let wires soldered to these half rings be attached to two little insulated rings also fixed on the shaft. The latter rings are connected

to the terminals of the machine or to the source of E.M.F. whose mean is to be measured. In addition let two brushes press on the circumference of the bands, forming with the bands a species of reversing key which will reverse the negative part of the E.M.F. provided the small space between the bands passes under the brushes at the instant that the E.M.F. is zero. Then if a voltmeter of the ordinary direct reading permanent magnet type be connected to the brushes it will read the mean value of the E.M.F. The brushes clearly must be adjusted in position round the disc until the voltmeter shows its highest reading. This apparatus is called a Half-time commutator, and by means of it the value of f can be found at once.

It may be noted that if we have pure sinusoidal waves we need not trouble about f , and the relation will become

$$W = \alpha n B^2 + \lambda n^2 B^2.$$

In most cases this is sufficiently near the true value for practical testing. We have thus a most convenient method for measuring the eddy current loss in a given sample of iron.

67. Verification of the law. By suitably adjusting the speed and excitation of the armature supplying the alternating pressure it is possible to run it at different speeds and different pressures. Suppose that we so adjust matters that the ratio of the speed to the mean E.M.F. as measured by the above apparatus is constant, it follows that this will involve the induction being the same at all the speeds taken. We can therefore see how the loss varies with various constant inductions, each known from the readings of the direct current voltmeter and the speed, the periods, n , being known from the speeds: in each case we can measure the mean power W by the wattmeter. Let us now plot the ratio W/n against n . It will be found that over the ordinary range of inductions it is almost a straight line. But if the induction be constant, the above equation takes the form $W = Pn + Qn^2$ or $\frac{W}{n} = P + Qn$, P and Q being constants when the induction is constant. Hence it follows that the expression is true as far as the eddy current loss is concerned.

68. Instantaneous curve method. Instantaneous values of flux and current can be determined by the following method, and

the resulting cyclic curve can be plotted from these. Let an insulating ebonite disc be fixed to the shaft of our motor and alongside it a conducting one; a brass ring, screwed on the side of the ebonite, will serve. Let a fine slit be cut in the ebonite at one point and insert a narrow brass slip right across the pair of discs. If then we have two brushes insulated from one another, one pressing on each disc, and if these be joined to any circuit, the circuit will be closed for an instant once per revolution of the armature, or once per period. Further, if the angular position of the brush which presses on the ebonite be capable of being varied and the position read on a circular scale, the instant of time, in the period, at which the contact is made can be determined. It follows that we can make any auxiliary circuit at a specified instant of the cycle. This periodic closure of a circuit can be used to actuate any device that may be suitable for measuring any pressure in the circuit under test. A simple device is shown in Fig. 53. The pressure whose shape it is required to find is applied to the terminals marked V ; these are connected to a reversing key so that the direction can be interchanged when necessary. T is a telephone, C is the rotating contact maker described above, and P is a sliding point which can be adjusted along a resistance across the ends of which is placed a battery, giving a pressure somewhat larger than the maximum value of the alternating pressure under test. It will be seen that by moving P along the resistance, matters can be so adjusted that the two pressures balance. When this is so the telephone will be silent, whereas when balance does not exist it will give a rapid series of ticks, one for each contact made on the ring; the effect can be intensified by placing a condenser across the terminals of the telephone. The actual value of the pressure is then read directly on the voltmeter. To investigate the pressure curve on the winding of our specimen, the terminals V may be placed across the ends of that winding; to find the current curve, we put in series with the winding a resistance of known amount and take the curve of pressure at its terminals. In this way we can rapidly trace out the shape of both pressure and current curves for the specimen.

Another simple method of tracing the curves is to use the contact maker and the source of pressure as a battery with which a condenser is charged and then discharged through a ballistic galvanometer. If a condenser of large capacity is available this enables very small pressures to be used, so that only a fraction of a

volt is lost in the resistance used in measuring the current. This practically removes from the pressure wave the distortion which we saw would be produced by a resistance in the circuit. But the pressure on the terminals of the coil on the specimen will now be far too large. This is got over by winding one or two turns round the specimen and using the pressure induced in those coils instead of the main pressure. The constant of the ballistic galvanometer can be found by placing a millivoltmeter across the terminals V and adjusting its deflection to any suitable value, using a separate direct current for the test.

When this method is used for accurate research, many small refinements are necessary, but the principle is the same. In this way it is possible to obtain the two time curves of pressure and

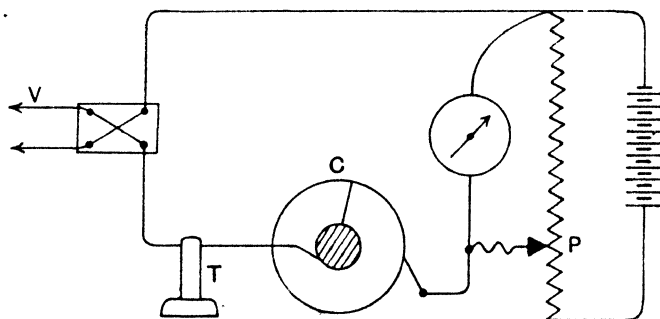

Fig. 53

current. In order to find the flux-time curve, it is necessary to integrate the E.M.F. curve from point to point. Since with ordinary forms of pressure curve the flux is zero when the E.M.F. is a maximum, the integration can be started at that point. The reduction of the results to B and H will be evident from what has gone before (p. 81).

69. The cycle as affected by eddies. The method just described is a very useful one. As an example take the curves in Fig. 54 which refer to a sample of iron plate of moderate thickness, about 0.014 inch, in which eddy currents were far from negligible. The inner dotted curve gives the true cycle as found by a ballistic test. The other two were found in the manner just described but at periods of 30 and 60 per second respectively. It will be seen that

the eddy currents have but little effect in altering the maximum induction attained either in respect to the value or the time, but that they cause a swelling out of the contour, with an increase in the coercive force. This is just what one would have expected, since the magnetising effect of the eddy currents has to be equilibrated by the impressed magnetic force applied by the coil. In samples of commercial thickness or of higher resistivity, this swelling is comparatively small. The loss per c.c. can be evaluated in the ordinary way from the area of the cycles.

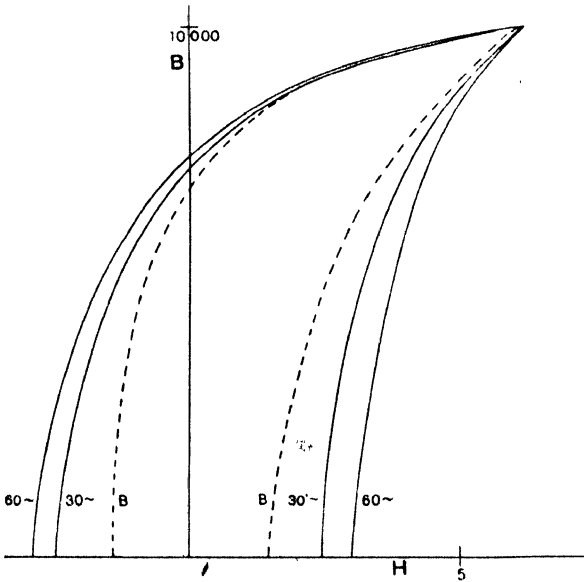

Fig. 54

70. Effect of a loop. It should be noticed that it has been implicitly assumed throughout that the E.M.F. wave impressed on the winding is such that the flux in the iron is always increasing from negative maximum to positive and vice versa, in other words the E.M.F. curve never crosses the zero line more than once between its maxima. If this be untrue, as may be the case with exceptional forms of E.M.F. curve, the flux will have a rise again on its way from maximum to negative maximum, or a loop will be formed as shown in Fig. 55 which is the actual form of a cyclic curve obtained by the method considered on page 88. The first point we note is that the

hysteretic loss is increased by the presence of the top and a corresponding bottom loop. Hence in addition to the loss incident to the main cycle we have an extra loss. It is remarkable that this can be expressed by a formula very similar to that for a full cycle, for it is found that if B_1 and B_2 be the terminal values of the induction in such a loop, the loss per cubic cm. is given by $\eta \left(\frac{B_1 - B_2}{2} \right)^{1.6}$. But in any case the hysteretic loss can no longer be expressed

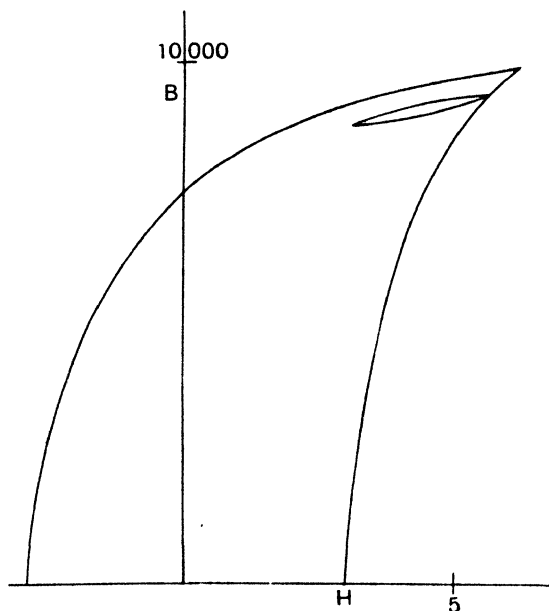

Fig. 55

solely in terms of the maximum induction attained in the cycle, hence it is no longer possible to use the formula on page 86. Such loops also have very marked effects on the eddy losses, for they take up quite a large part of the time available for the whole cycle, in this case nearly one-half. Hence the main change of flux has to be executed far more rapidly so that the rates of change of flux being thus increased, the eddy losses are greatly exaggerated. For example the curve in Fig. 55 refers to the same sample as those in Fig. 54 and was taken at 30 periods per second. It will be seen that

the main cycle in Fig. 55 corresponds very well with that of a normal cycle at 60 periods in Fig. 54, and thus the eddy loss appropriate to 30 periods is nearly doubled due to the loop. Hence the formula is inapplicable for eddy losses as well as for hysteresis, unless the flux curve is devoid of dimples.

INDEX

- absolute unit of current, 14
- amp, 55
- alternating E.M.F., 34
- ampère defined, 14
- ampere magnetic force, 70
- $B-H$ curves, 39, 40
- back E.M.F., 30
- bar-ended magnet, 1
- battery galvanometer, 20
- bathtub, Dr, 44
- charge, magnetic, 72
- crossed position, 7
- Chattock, Prof., 67
- Circuit, magnetic, 66
- Coercive force, 48
- Collector, 32
- Commutator, 32
- Compass, 4
- Controlling couple, 20
- Corkscrew Rule, 12
- Cycle, magnetic, 46, 48
- Damping factor, 34
 - of galvanometer, 34
- Dead beat galvanometer, 34
- Declination, 4
- Deflecting couple, 20
- Demagnetising factor, 71
 - by reversals, 57
- Derived flux units, 41
- Diamagnetic bodies, 38
- Dip, 4
- Dispersion coefficient, 75
- Displacement, magnetic, 22
- Double yoke method, 71
- Dynamo, 30
- Dynamometer, 17
- E.M.F., induced, 24, 28
- Earth's magnetic force, 4
- Eddy currents, 60
 - loss in cycle, 89
- Electromagnet, 1
- Elongation, 20
- End-on position, 6
- Equipotential line, 10
- Ewing's Molecular Theory, 78
- Faraday's Law, 26
- Field, magnetic, 3, 8
- Fling, 20
- Flux, magnetic, 22
 - measurement, 36
 - total, 23
- Flux-Turns, 25
- Force between coils, 17
- Force, magnetic. *See* Magnetic Force
- Form factor, 86
- "Gauss," 3
- Half-time commutator, 87
- Hardening, magnetic, 45
- High inductions, 43
- History, magnetic, 55
- Hysteresis cycle, 46
- Induced E.M.F., 24
 - voltage method, 63
- Induction, magnetic, 23
- Initial part of $B-H$ curve, 42
- Instantaneous curves, 87
- Intensity of magnetisation, 77
- Kapp's induced voltage test, 64
- Knee of $B-H$ curve, 42
- Lamination, 62
- Leakage, 69
- Line of Force, 9, 23, 24
- Loops, 55, 90
- Loss in iron strips, 84
- Lost energy, 51
- Magnet, 1
- Magnetic bridge, 72
 - circuit, 66
 - cycle, 48
 - displacement, 22
 - Field, 3, 8
 - Force, 3
 - applied, 70
 - of current, 11
 - circular coil, 13
 - element, 12
 - long wire, 15
 - solenoid, 16

- Magnetic flux**, 22
 .. history, 55
 .. induction, 23
 .. moment, 6
 .. needle, 4
 .. pole, 1
 .. potential, 10, 26, 67
 .. tester, 57
Magnetism, 22
Magnetometer, 5
Magnetomotive Force, 67
 "Maxwell," 23
Moment, magnetic, 6
Morris and Longford, 64
Moving coil galvanometer, 18
Mutual Inductance, 36

Needle, magnetic, 4
Neutral axis, 31
Neutral point, 9

Paramagnetic bodies, 38
Perfect magnetic circuit, 69
Permeability, 40
Permeance, 70
Periodic time of galvanometer, 21
Pole, magnetic, 1
 .. strength, 2
Potential, magnetic, 10

 "q," 75
Quantity of electricity, 20

Refraction of flux, 74
Reluctance, 69
Reluctivity, 41, 69
Remanent induction, 48

Rotating hysteresis, 58

Saturation, 42, 45
 .. value of B , 60
Screening, 61
Searle, Dr., 2, 42, 45
Self-demagnetising force,
Shear of curve, 71, 72
Solenoid, 16
Solid angle, 26
 "Stalloy," 55
Standard field, 36
Steady current constant, 20
Steinmetz formula, 52
Step by step method, 45, 53
Stray flux, 69, 73
Strength of field, 3
 .. pole, 1, 2
Susceptibility, 77

Tangent galvanometer, 14
Tester, magnetic, 57
Total flux, 23
Tube of Force, 24
 .. Induction, 24

Uniform magnetic field, 4
Unit pole, 3
 .. tube, 24

Vibration magnetometer, 8
Virtual current, 17, 82

Wattmeter, 18

Zero-reading instrument, 17

