

UNIVERSAL
LIBRARY

OU_160733

UNIVERSAL
LIBRARY

BLACKIE & SON LIMITED
16/18 William IV Street, Charing Cross, LONDON, W.C.2
17 Stanhope Street, GLASGOW

BLACKIE & SON (INDIA) LIMITED
103/5 Fort Street, BOMBAY

BLACKIE & SON (CANADA) LIMITED
TORONTO

MAP MAKING

BY

FRANK DEBENHAM, O.B.E., M.A.

Fellow of Caius College
Professor of Geography, Cambridge University

THIRD EDITION

BLACKIE & SON LIMITED

LONDON AND GLASGOW

First published, December, 1936
Reprinted, March, 1937
Second edition, 1940
Reprinted, 1942, 1944, 1947, 1948, 1951
Third edition, 1954

Printed in Great Britain by Blackie & Son, Ltd., Glasgow

PREFACE

At some time or another everybody, whether layman or specialist, needs a map. Maps are common, and most people are able to extract from them such information as they require without becoming skilled map-readers. Considering this universality of maps and the use of maps, it is strange that the making of maps is still regarded as somewhat of a mystery, involving, it is thought, the use of strange and expensive instruments, acquaintance with the higher mathematics, and a high degree of perfection with the pen. This is not so, for reasonable maps can be made with the simplest of instruments, mathematics of the middle school standard, and a moderate ability only with the drawing pen. That we, in England, should regard surveying with a certain amount of awe is partly due to the fact that the surveyor is hardly ever seen, and when he is seen he is usually either an engineer's assistant taking levels in a town, or a non-commissioned officer of the R.E. working for the Ordnance Survey. If the latter, the disappointment in what he is doing will generally be intense, since he has merely a map already printed on a drawing-board and perhaps a chain with him, and practically none of the paraphernalia which is normally associated with the occult art of topographic surveying.

It will be suggested, of course, that since the British Isles have been so thoroughly mapped for the past century and a half, there can be little need for the amateur to repeat the work of the professional. For a large number of uses for

maps it is true that the various scales, from the 25-in. to the mile downwards, published by the Ordnance Survey, will be entirely adequate. Nevertheless, anyone who specializes in data which have a distribution characteristic, whether it be botany or birds' eggs, geology or land-forms, will soon find that he is limited, if not seriously hampered, by the professional map. It may be that the scale does not suit his particular activity, or that the vertical interval of contours is too great, or even that the detail already on the map prevents him from adding as much as he wishes of his own.

As Head of a Department which attempts to turn out all its students equipped with the necessary knowledge and some of the experience for making maps of small areas, the author is disappointed to find that there is still rather a feeling amongst field scientists that surveying must be left to a specialist. It is surprising to find that very many geologists and most botanists, scientists whose study is essentially of the distributional type, are never taught to make maps of this kind. This book, therefore, is designed to show the upper-form schoolboy, or the first-year student at a university, or the field-scientist, that the mapping of small areas is not only a simple matter but can be very interesting, that it is not necessarily an expensive hobby, and that, for the purposes he will have in mind, an appropriate order of accuracy is readily attained. The treatment will probably meet with a certain amount of scorn from the professional surveyor, but no apology is made for attempting to show that reasonable work can easily be done by the amateur geographer, geologist or botanist, or even by the person who is interested in topography for less specific reasons.

PREFACE TO SECOND EDITION

It is refreshing to find from correspondence with readers that some of the remarks in the original preface are rapidly becoming unnecessary. Not only is the cult of making your own maps growing amongst field scientists but the demand for instruction in schools appears to be increasing.

Nor is the book scorned by the professional as I had feared, for two of the most interesting commendations came from a hydrographic surveyor in the Arafura Sea and from a senior member of a Topographic Survey Department in West Africa.

Thanks to correspondents a few mistakes are corrected in the new edition, and there are a few insertions necessary to keep the book abreast of developments.

F. DEBENHAM.

DEPARTMENT OF GEOGRAPHY,
CAMBRIDGE, *January, 1940.*

CONTENTS

CHAP. ✓		Page
I.	INTRODUCTION: SOME GENERAL PRINCIPLES - - - -	I
II.	SCALES AND THEIR LIMITATIONS - - - -	13
III.	THE MEASUREMENT OF DISTANCE - - - -	29
IV.	THE SURVEY OF SIMPLE ENCLOSED AREAS - - - -	45
V.	MEASUREMENT OF DIRECTION: THE COMPASS - - - -	55
VI.	THE COMPASS TRAVERSE - - - - - - - -	71
VII.	DETERMINATION OF HEIGHT - - - - - - - -	99
VIII.	THE PLANE TABLE - - - - - - - - - -	131
IX.	FURTHER CONSIDERATIONS IN PLANE-TABLING - - - -	173
X.	SURVEYING WITH THE HELP OF PHOTOGRAPHS - - - -	191
XI.	INSTRUMENTS - - - - - - - - - - - -	205
	Appendix I. LETTERING - - - - - - - -	225
	Appendix II. CONVENTIONAL SIGNS - - - - - - - -	229
	Appendix III. HOW TO USE THE TRAVERSE TABLES - - - -	235
	NATURAL TANGENTS - - - - - - - - - -	236
	CHORDS, SINES, TANGENTS, COTANGENTS, COSINES - - - -	238
	INDEX - - - - - - - - - - - - - - - -	239
	TRAVERSE TABLES - - - - - - - - - - - -	facing 238

Chapter I

INTRODUCTION: SOME GENERAL PRINCIPLES

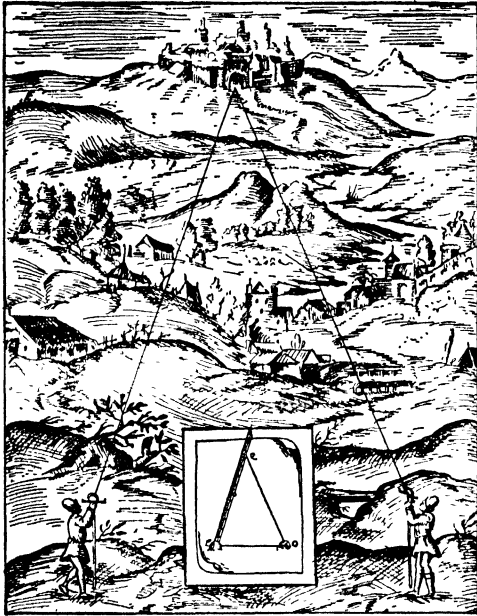

After Danfrie, 1597

“Therefore, leaſte you ſhulde be left deſtitute of the principal treſure of Coſmographie, that is to delineate, protract, or ſet forth the platform of the face of the earth: or els perticulerli any one portiō of the ſame: I will do my endeuer to ſhewe you the waye how to attain hereunto.”

*The Coſmographical Glaſſe,
WILLIAM CUNNINGHAM, 1559.*

THE scene was a North Country inn, and a stranger was being given meticulous advice as to how to reach a certain place over the moors, but since he was so much a stranger that he understood little of their talk of "scars" and "grikes" and "becks" he was still hazy as to his route, until a certain old shepherd took him in hand.

The old man placed five beer mugs carefully on the table in an irregular line, and named them one by one, "Whitescar", "Yeats' Farm", and so on. Then, dipping his finger in a puddle of beer, he traced a wavy line amongst them; each turn referred to its landmark, the nearest beer mug, until a route map was completed, which indeed served its turn.

Now here was the very essence of all map-making, the beer mugs first with immense care, and then the line traced with reference to them.

If you have doubts upon the matter, ask any ordinary boy to draw a route he knows well. He will start from one end and go ahead referring each turn to the last one, getting his scale and his directions more and more wrong, until he seeks a rubber to amend what he knows is wrong as a whole, and yet is not so bad in detail. The boy is following a natural instinct to begin at the beginning and go through to the end, but the specialist in beer mugs was wiser in beginning at the end, that is to say, by viewing the area as a whole, and then using his skeleton of the whole as a guide for the different parts.

It is a fundamental principle in all surveying to work from the whole to the part, and to use a framework of guide-marks or guide-lines on which to fit the lesser detail, a principle which is employed alike by the heads of the great trigonometrical surveys of the world, and by the amateur who wishes to make a map of a few small fields or a watercourse. In the first case the construction of the framework is a matter

for years of very precise observation with expensive instruments, and of laborious computations demanding considerable facility with mathematics; in the latter case the framework is made at the same time as the details are put in; but in both cases the framework is the essential part of the work.

So we must study this question of a framework for our map-making, and although it will not be as simple as the setting of beer mugs on a table, it need not teem with mathematics, as the beginner is apt to suppose. The word "triangulation" may be to the professional surveyor as blessed as was "Mesopotamia" to the religious old lady, a sure foundation carrying vague contentment to a soul harrowed by a world of faults and errors, but to the geographer who has forgotten his logarithms and shudders at trigonometry it may be an accursed word, until he realizes that it is founded on nothing more advanced than the first book of Euclid, and that, in plane-tabling at all events, it can all be done graphically, without a single computation to worry him.

The reason for the general ignorance of this fundamental process in map-making is the fact that the framework of points or lines never appears as such in the finished map, and since it is founded upon common sense, we may explain its purpose thus.

The detail of nature, such as we wish to record on maps, is woefully disorderly and haphazard. Rivers never run straight, hilltops dot the country without any apparent pattern, and lakes are shapeless things, while contours meander dubiously round the hillsides. Even the works of man are irregular, so that rarely do we meet a perfectly straight road or boundary, and, except in towns, no man sets his house parallel to those of his neighbours.

The map-maker, in fact, is presented with a myriad details which he has to place in their correct relation to each other, yet they are situated according to no plan whatever, they are haphazard to a degree. But he has a remedy, and that is the

straight line. He can see straight, he can stretch a line or chain straight, and he can draw straight lines on paper with the simplest of instruments. He therefore superimposes over the diversity of natural features a straight line, which he can measure in the field, and draw on his map, and then by side measurements from it he "picks up" the curves of his stream, the wanderings of his roads, or the positions of his hilltops and his houses. If, as is usual, he needs more than one straight line to follow the detail, he records the angles between the straight lines, and he can then plot the series. This operation he calls a traverse.

Should it be a case of finding the position of a feature across a lake, or in some other visible but inaccessible position, he modifies his straight line system. He measures one line, as a base, and notes the direction from each end of it of the inaccessible object. He then has a triangle from which, by using the length of the base and the basal angles, he can find the position of the unknown point either by plotting it to scale or by calculation. This he calls triangulation.

In these two operations of traversing and triangulation by a framework of straight lines we have an epitome of the whole art of plane surveying; for every survey is made by means of one or the other or both, and the subject-matter of the largest textbooks of surveying is but the adaptation or refinement for special purposes of these two methods of using straight lines. The determination of differences of height is founded on similar principles.

The framework for all types of survey, therefore, consists of straight lines, which are either measured along the ground or are sight lines of which the direction only is measured, and the lengths are calculated. But this framework, or "control", does not appear on the final map, and we must now consider the methods by which the detail, which does appear on the map, is "picked up" from the guide-lines or points. Much of it is put in by minor measurements from the framework, and in very precise surveys all of it is so obtained, but in all

ordinary topographic mapping and certainly in the type dealt with in this book, the greater proportion of the detail is drawn in by eye, that is, by estimation of distance and direction.

Such a statement is perhaps somewhat shattering to the delusion under which many users of maps suffer, that all parts of a map are equally accurate and infallible.

We shall see when we come to consider the scale of a map that for any given scale there is a definite degree of accuracy beyond which it is quite useless to go in fixing any detail, but apart from that there are two common-sense reasons why sketching features by eye should come into map-making.

In the first place, there is a limit to the time and money which can be expended on a map. For instance, were every minor curve of a stream to be carefully measured, surveying would be indeed a tedious and expensive business; consequently, such curves are put in by eye from certain fixed points along the stream.

Secondly, much of the detail which quite rightly appears on a map is itself indefinite and unworthy of accurate measurement. What, for instance, constitutes a river bank? Is it the water level? and if so, should it be at flood level or low water, or a mean of the two? Or should it be the line marking a definite change of slope, and if so, who is to judge where that change is definite?

In such a case the surveyor will be justified in drawing in by eye what he personally considers to be the line of the river bank, for it is quite an indefinite line. When, on the other hand, he reaches a weir or a bridge which is not only a work of man and both important and valuable, but is a clearly defined feature, he will do well to take his measurements of length, breadth and position with care, and thus be able to vouch for its correct delineation on his map.

So, for these reasons, besides others, there is justification for the sketching in of detail by estimation, and it is in this aspect that the making of maps becomes an art rather than a science.

Just as in any other form of sketching, some people are more apt at drawing detail than others; but a great deal can be learnt by the application of a few maxims and we propose to end this hitherto theoretical chapter by a practical consideration of sketching by eye.

It can be laid down as an axiom that ability in field sketching depends upon three things: first, a capacity for judging direction and distance; second, the co-ordination of hand and eye which enables one to transfer the features on to paper; and thirdly, the possession of a sense of topography, an appreciation of land forms.

Now estimation of distance obviously requires nothing but practice to render one proficient, a facility in drawing can be cultivated if not perfected by frequent application, and a sense of topography comes with experience; in a word, a student has but to be keen to become reasonably apt.

The stages suggested for this necessary practice are as follows, though circumstances or situation may entail a different order of procedure.

It is best to begin with memory sketching, using the "mind's eye", that neat expression which means the picture summoned up by memory. Select some familiar route, whether river, road or railway, or even a town, and sketch it in plan from memory, not forgetting to begin by putting in certain well-known features on or near the route first. The first attempts will probably show up certain tendencies which seem to be innate, the exaggeration of curves, the magnification of the straighter and more monotonous parts of the route, the inclination to draw all cross roads at right angles, &c.

Nevertheless, in producing a plan which is reasonably close to the original the first attempts will probably be fairly satisfactory, and each fresh trial will improve greatly upon the last. Some dissatisfaction is likely to arise from lack of practice in drawing the irregular shapes and curves of natural features. as well as from lack of familiarity with the conventional

signs in common use for map work. And since it is as well to become accustomed from the first to these conventions, they are considered in an appendix, together with a pattern, which, of course, can be varied within limits to suit the taste and fancy of the sketcher.

Memory sketching is valuable as a first step, for it is not a direct sketch from nature, but rather from a picture of nature, and in so far as that picture within the mind is accurate, so will the result be satisfactory. Further, a comparison with an actual map will generally be possible, serving as a check on, and a criticism of, early attempts.

The next stage is to find a small hill or other point of vantage, whence a fair amount of detail can be seen, and to attempt to put that on paper, again using the principle of putting in the leading landmarks first.

Here the operation is different from the last in that it involves the transference of what is really a perspective view into the view of the same area as seen from an aeroplane.

The sketcher is assisted by a few elementary principles which occur to him naturally as he proceeds, such as that objects which are in line with one another as he looks at them will be along a straight line on the map. He learns almost instinctively to allow for the decrease of size of objects with distance even though he might not be able to state it as decreasing in proportion to the square of the distance.

Naturally the result will be more satisfactory if the area which is being sketched is familiar, in which case memory comes in as an aid to vision. On the whole the first efforts in this direction may be somewhat disappointing, unless a very small area is taken, and it is not until the sketcher is familiar enough with contour lines to see them in imagination on the hillsides that this type of field sketching becomes interesting and satisfying.

There is a third and final stage in the practice of field sketching, and one which will prove quite invaluable to the geologist or the student of land forms, or indeed to anyone

who is interested in recording the shape of the ground surface for any reason, for as soon as some facility is acquired, it is an extraordinarily quick and easy way of recording those land forms which, however simple in themselves, defy verbal description.

Take as an instance the case of a stream talus, or debris fan, sloping steeply between two ridges as shown in the perspective sketch (fig. 1). To describe in words the shape of such a feature would take pages, to sketch it requires some measure of aptitude and a certain expenditure of time, but to make a form-line sketch of it as in fig. 1 takes very little time, and shows all the important features of the land form.

Contour lines are imaginary level lines, such as would be traced by successive shore lines of an imaginary sea rising over the land, and the usual convention in mapping is to show them at equal intervals of height above sea level. As can readily be imagined they entail a great deal of field-work if they are to be surveyed at all carefully. Once mapped, however, they are of the greatest value in showing the form of the surface, and if they are sufficiently close together they do this almost as effectively as and much more accurately than shading or hachuring.

Form-lines, on the other hand, are what we may term unsurveyed contour lines, that is to say, contours which are drawn in by eye, with perhaps occasional reference to known heights. Their purpose is simply to show the land forms, and they are of no particular height and are not of equal interval. As these lines are being written, there is to be seen across the valley an old lateral moraine of an ancient glacier now well covered with grass, but showing in the evening shadows the rather intricate form which is peculiar to such land forms, especially when they have been cut through by streams from the heights above. Such a feature, with its basin and sharp ridges, its benches and abrupt little valleys, is quite beyond a brief description, but to those who are familiar with reading contours the attached sketch plan with

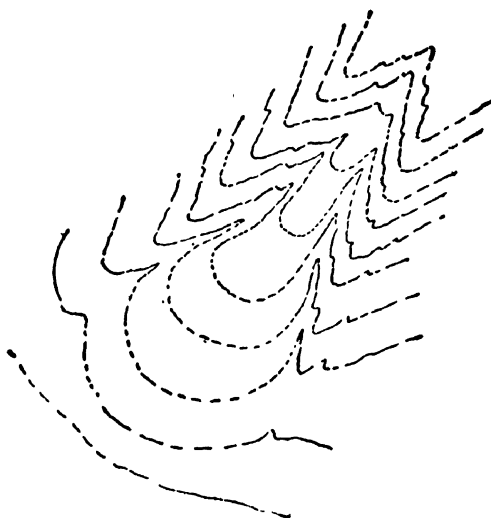
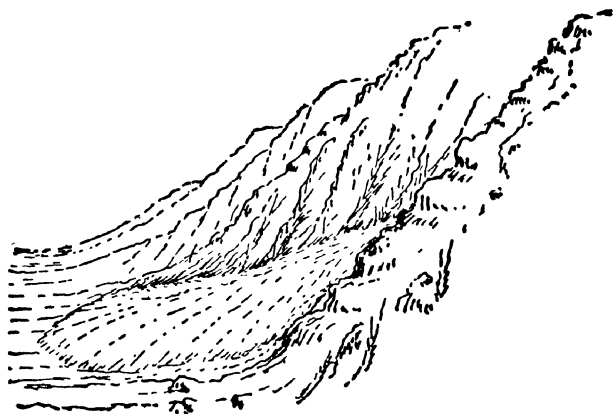

Fig. 1.—Perspective and form-line sketch of a talus cone

form lines, the work of four minutes, will probably convey all the essential points of the relief (fig. 2).

For preliminary practice it is best to take a small stream and its valley, for the stream bed itself, being the lowest level, is a fixed line for the form-lines, which will all turn sharply back as they cross the stream. Having drawn in the stream and any well-marked features near by, such as single trees, field corners, rocks or cliffs, it will be found fairly easy to select a point on the stream for the first form-line, to follow it in imagination down the valley on each side, and

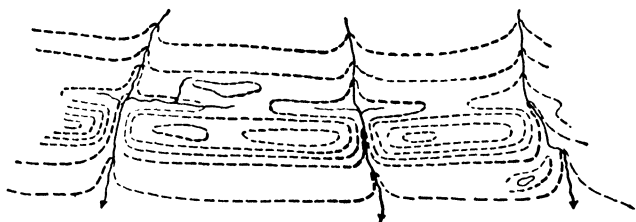

Fig. 2.—Form-line rendering of old lateral moraine cut through by streams

sketch it in on the plan. It is as well to adopt the convention of using a broken line for form-lines, which will then not be mistaken for roads or boundary lines.

We may assure the dubious reader at this point that exercises such as these, however inexact and inartistic the results, are an important preliminary in the training of a map-maker, and not to be scorned as elementary and childish. For, besides cultivating a facility with the pencil in drawing, they will gradually build up in the beginner a topographic sense, perhaps the most important attribute for the surveyor.

A very high officer in military geographical circles has asserted that the only way to teach a beginner either to read maps or to make maps is to "give him a plane table and keep him at it until he understands country". The delightful phrase "to understand country" is perhaps hardly more

illuminating than talking of a topographical sense, but that they both describe a very real faculty will perhaps become apparent as the reader proceeds.

Chapter II

SCALES AND THEIR LIMITATIONS

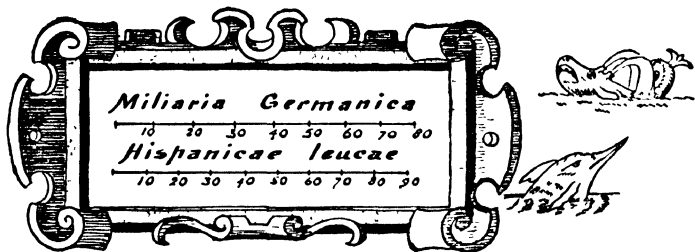

After Linschoten, 1599

“ And you may also make a scale, or reule, containge in it the quantitye of miles, from one to an hundredth if you please, and by this menes you may take with your compasse the distance of ij places, and you shall find the perfecte distance.”

The Cosmographical Glasse,
WILLIAM CUNNINGHAM, 1559.

A MAP is intended to be a miniature of the country it represents, in so far as a flat surface can imitate one which is actually in relief, but it is severely limited by several factors, such as the necessity for finding room for names, and indeed the only true facsimile in miniature on a flat surface is an aeroplane photograph.

A map must be some fraction of the true size of the area mapped, and every length on the map must be some fraction of the true length on the ground: this is the "scale fraction" or "scale" of the map. Our curiously haphazard system of measures leads us to prefer to speak of a scale as 1 in. to the mile instead of $\frac{1}{63360}$, or a $\frac{1}{4}$ -in. map when we mean that the map is $\frac{1}{440}$ of the real thing, but in the making of small area maps it is much more convenient to leave inches and miles alone, and to choose round figures such as $\frac{1}{10000}$. However, the actual method of naming the proportion does not matter much, provided the surveyor is quite clear as to the meaning of the figure, and its limitation. A little consideration will show that however truly the scale fraction may apply to the map as a whole, it cannot apply to all the detail.

Thus, if the ordinary 1-in. map ($\frac{1}{63360}$) of the Ordnance Survey be taken, and the width of the roads be measured by the scale line at the bottom of the map, the average road will appear to be about 120 yd. wide: in other words, certain detail is too small in reality to be shown true to scale. The following short sum shows us that on the 1-in. map a road true to scale would be insignificant, supposing the road to be 30 ft. wide.

On this scale 63,360 in., or 5280 ft., on the ground is represented by 1 in. on the map.

\therefore 1 ft. on the ground is represented by $\frac{1}{5280}$ in. on the map.

\therefore 30 ft. on the ground is represented by $\frac{30}{5280}$ in. on the map.

It follows that the width of the road on the map should be, if the scale be adhered to, exactly $\frac{1}{176}$ in., which is a finer line than can be drawn without very special care.

The roads, therefore, are shown greatly exaggerated in scale, for they must be seen easily if the map is to be of use. Provided the map-reader realizes the breakdown of the scale it does not matter very much, though the motorist will find that what looks on the map like a gradual curve of the road may be a very sharp one, the sharpness being concealed by the smoothing off effect of the double line, a zig-zag turn of 100 ft. or so being quite hidden between the double lines, unless the map draughtsman is very skilful.

The limitations of scale, therefore, affect the reading of a map, for much of the detail must of necessity be exaggerated, or, as it is usually termed, conventional.

An interesting example of the need for care in map reading will be apparent if one considers the width of the Thames, as shown on our 1-in. O.S. maps. At Gravesend the map reader may safely measure the width across the river from the map scale, but obviously at Oxford the blue line is of conventional size, and does not indicate the width correctly. Somewhere between these two points the draughtsmen have had to give up drawing the river to scale, and it would be an improvement on such maps if that point were made clear on the map itself.

The reader may prove this inevitable "breakdown of scale" for himself quite easily. Draw, to some simple scale such as 100 yd. to the inch, the following detail: a field 300 yd. square with a garden in the corner 30 yd. square. Now put in the corner of the garden a house 30 ft. square, with a porch 3 ft. square and a sundial in front of it 1 ft. square.

Even if the tiny square for the house is managed it will be impossible to draw the porch, only $\frac{1}{100}$ in. square, and the sundial is quite out of the question. But if the map-reader must use caution over measurements from a scale, it is still

more important for the map-maker, both in choosing his scale and in making his field-work conform to it.

Before considering the factors which affect the choice of scale for a map, we must pay some attention to the limitations in the drawing of fine lines, especially pencil lines in the field, for, after all, the degree to which it will be possible to show detail true to scale will ultimately depend on the fineness of our drawing.

A short exercise or two will soon show the reader that fineness of line is strictly limited, partly by the state of the pencil point, partly by steadiness of hand. Let him take a smooth sheet of paper, and having put on it the finest dots and lines he is capable of, let him examine it under a strong lens. He will find that his best efforts under these easy conditions are about $\frac{1}{100}$ in. in thickness. The following is another way to find the

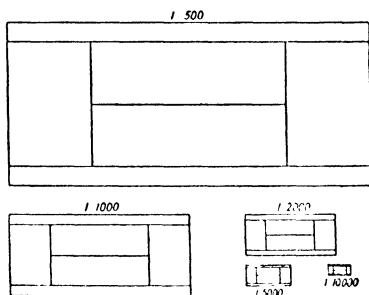

Fig. 3.—Tennis court drawn to different scales

thickness of line. Using a clearly marked scale, set out two parallel straight lines exactly $\frac{1}{10}$ in. apart, and join them by a line AB at right angles. From A and B set out lengths of $\frac{1}{10}$ in. in opposite directions for 1 in., ending at C and D. Finally, rule fine lines joining these marks as shown in the figure.

Then, if these fine lines are separate, he knows that they are finer than $\frac{1}{100}$ in., for 10 of them are included in $\frac{1}{10}$ in. (strictly speaking, slightly less than $\frac{1}{10}$ in.). If they merge into one another then they are somewhat coarser than $\frac{1}{100}$ in. With a little care it is possible to keep them separate, but it will be appreciated after a few attempts that pencil lines in the field will rarely be as fine as that, and that he may as well accept $\frac{1}{100}$ in. as the best he can do.

Fig. 4 illustrates these points with lines drawn to a definite thickness.

Bearing these limitations to scale and to drawing in mind, we may now consider how to set about choosing the scale for any map we wish to make.

In choosing the scale for his map, the surveyor has three factors to consider, first, the size of the paper available, secondly, the amount of detail he wishes to put on the map, and thirdly, the size of the detail which he wishes to show true to scale.

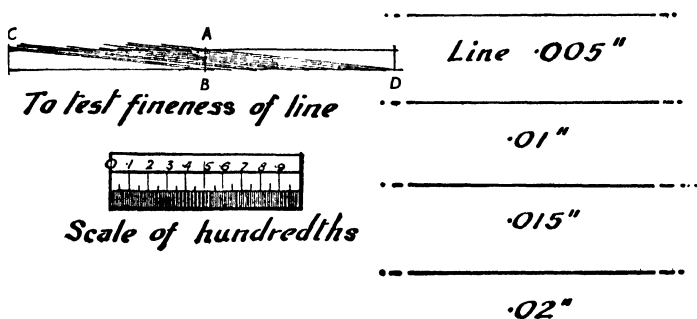

Fig. 4

The size of the paper is, within limits, a very variable factor, unless a method of graphical surveying is used which necessitates a definite size of sketching board or plane table.

The amount of detail to be shown is usually settled by the purpose for which the map is being made, and the purpose usually includes the emphasis of certain features which should, if possible, be shown true to scale.

Often enough these three factors are incompatible with one another, and it becomes necessary to do some juggling with them in order to effect a reasonable compromise. Let us work out an actual case, and illustrate in that way both the problem and the simple arithmetic involved.

Let it be supposed that the surveyor wishes to make a map of a valley 4 miles long and 2 miles wide, and he would like

to show the stream true to scale, its minimum width being 30 ft. His sketching board or plane table is 18 in. square, and he would like to show contours at 20 ft. intervals, the maximum slopes in the valley being 1 in 5.

The problem as to the size of the paper presents itself thus: 18 in. divided by 4 miles gives the fraction

$$\frac{18}{4 \times 63360} = \frac{1}{14080},$$

so that, choosing a round figure, the scale of $\frac{1}{13000}$ seems indicated.

The stream problem, on the other hand, works out as follows at that scale:

15,000 ft. on the ground will be 1 ft. on the map,

so

30 ft. on the ground will be $\frac{1}{300}$ ft.,

or

$$\frac{12}{300} = \frac{1}{40} \text{ (nearly) of an inch.}$$

Now it requires very good field draughtsmanship to draw fine lines exactly $\frac{1}{40}$ in. apart, so he must increase the scale of his map if he is to satisfy that particular object.

The contour problem can be stated in this way. He wants his contours to be distinct from one another, and, as we have seen, he cannot rely on his field drawing being capable of lines less than $\frac{1}{100}$ in. thick, that is to say, $\frac{1}{30}$ in. from the centre of one line to the centre of the adjacent one. A slope of 1 in 5 is the same as one of 20 ft. in 100 ft., so that his closest contours on the ground will be 100 ft. apart horizontally.

The scale chosen, then, must permit of 100 ft. on the ground being shown by at least $\frac{1}{30}$ in. on the map. Dividing one by the other, we have a scale of

$$\frac{1}{30} \div 100 \times 12,$$

or

$$\frac{1}{50 \times 100 \times 12} = \frac{1}{60000},$$

at which result the surveyor sighs with relief, for he sees that the size of his paper will easily allow the desired closeness of his contours.

He can now state the problem as a whole in this way. The paper size indicates a scale of 1 : 15,000, and that scale will easily allow his contours to be separated; indeed, the nearest they will approach will be about $\frac{1}{8}$ in. On the other hand, that scale will not permit him to draw his stream in with a double line true to scale. His alternatives are, then, either to use the scale $1\frac{1}{3}\frac{0}{00}$ and to be satisfied with a single line, minimum width of $\frac{1}{40}$ in., for his stream, or to use two sheets for the area and thereby double his scale up to $7\frac{1}{3}\frac{0}{00}$ or thereabouts.

Once the scale is chosen, the surveyor will be able to settle another important preliminary to beginning his field-work, and one which is usually quite overlooked by the amateur. It will be a great saving of time and patience in the field if he knows beforehand to what precision he need go in measuring the distance of detail from his fixed points or guide-lines. Many people, including even professional surveyors, waste much time in the field in measuring to tenths of a foot when the nearest foot will do. By detail in this case we do not mean the indefinite detail spoken of in the last chapter, such as the ragged edges of ditches, or the uncertain bank of a river, but really well defined detail such as walls, or house corners, to which it is possible, if desired, to measure to a fraction of a foot.

He argues in the following way. He knows that his finest line is of the order of $\frac{1}{100}$ in., but that in practice he cannot do much better than $\frac{1}{30}$ in., both for drawing lines and for measuring with his scale in the field. He next finds the value of this personal limit of $\frac{1}{30}$ in. in terms of the scale he is going to use. Thus, in the last example, having settled on the scale of 1 : 15,000 he works out the small sum:

1 in. on the map is equivalent to 15,000 in. in the field,
 $\frac{1}{30}$ in. on the map is equivalent to $1\frac{5000}{30}$ in. in the field,

that is to say, 300 in. or 25 ft. This means that his finest point drawn on the paper will be equivalent to 25 ft. on the ground. It means, further, that if from one of his guide-lines he measures to any object which is less than 25 ft. from the line, the dot representing the object will merge into the line. For practical purposes, he can assume that he cannot draw the position of any object to a greater accuracy than about half the value of his thin lines, that is to say, to about 12 ft., and this he calls his "plottable error", or, the possible error to which his comparatively clumsy plotting of lines condemns him for that particular scale.

If he cannot plot his detail to a greater accuracy than 12 ft., it is no use measuring to a greater accuracy than that, and the realization of this fact will save an enormous amount of labour. For instance, any measurement he makes need only be within 12 ft. of its true value, which means that chaining, if used at all, can be rapidly done, and that pacing, which should not have an error greater than 2 or 3 per cent, can be used up to at least 100 yd. Moreover, many of his side measurements can be done by estimation, for with ordinary practice one can estimate up to at least 20 yd. without being more than 12 ft. in error. The scale of 1 : 15,000 is rather small for the type of mapping considered in this book, and, of course, for larger scales the plottable error will be reduced in proportion, but it should be clear that once the scale of the map-to-be is chosen, the small calculation to find the plottable error is well worth while.

A word of warning about the plottable error is necessary before leaving the subject. It should be clearly understood that it varies strictly with the scale, and that any series of measurements in the field must be made to an accuracy suitable to the largest scale to which they are likely to be plotted. In the case of a traverse, the figures are usually put down in a notebook, to be plotted at another time, and the final scale may not be settled when the field work is being done. Further, if the measurements are not made only for plotting but are

also to be used in calculations, it is clearly quite wrong to speak of a plottable error at all, and the accuracy of the field measurements will be governed by quite other considerations. Thus, in the case of the traverse of a field, if the lengths of the lines are to be used for finding the area by calculation, they should be measured with a much greater accuracy than they can be plotted.

With these warnings as to the use of the term "plottable error" we may proceed to consider one or two points about methods of plotting.

Plotting Materials

Although every finished map, whether in manuscript or in print, is in ink, the map-maker's real plotting instrument

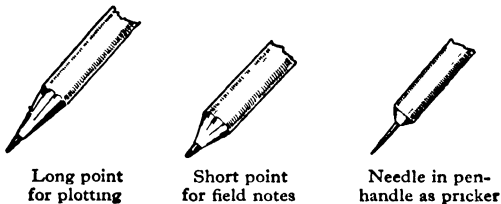

Fig. 5

is the pencil, with which all preliminary work is done, and it therefore behoves him to choose his pencil well and to use it correctly. What has been said about fineness of line is enough to show that he must obtain a fine point on his pencil and cherish it. In spite of all inventions which are said to sharpen pencils perfectly, the amateur draughtsman will probably find that the old-fashioned penknife will serve him best for making a long and fairly sharp point, which is finished off on very fine sand paper, or, better still, on an odd piece of rough drawing paper. After a few lines have been drawn a slight polish on the rough paper will bring up his point again. A chisel-shaped point may be useful for drawing a number

of ruled straight lines, but for general plotting it is of no use.

Opinions differ as to the hardness of pencil to be used. Nothing softer than HB is advisable, and since this wears away rapidly and may rub and smudge, an H is recommended for most work, and many prefer a 2H, in spite of the fact that its lines are less visible, and involve a certain amount of pressure, and therefore scoring of the paper.

Since plotting usually begins with a series of straight lines ruled for definite lengths, a ruler and a scale are necessary. For ordinary work there is no reason why the ruler should not also have the scale marked on it, but in the kind of maps we are concerned with here, the scale will usually have to be specially prepared as described below. The only desiderata about a ruler are that it shall be straight and fairly heavy, and shall not mark the paper. Its straightness can be tested by ruling a line with it, and then reversing the ruler end for end, ruling another parallel to it, when any defect will show up as a curve.

A good wooden ruler with inset metal edge will serve if this test is occasionally made; but for regular work it is advisable to have a steel ruler with bevelled edge.

The scale, if of wood or metal, must have a bevel to a really thin edge, and the scale lines must be fine. There are many scales of good patterns on the market, but the most useful for the purpose of plotting surveys is one specially designed for the use of geographers,* shown in figs. 5*a* and 5*b*. The selection of scales, size of the protractor, &c., have been chosen so as to suit the type of topographic mapping described in this book. Even so the map-maker will often be resorting to a scale which is not on any rule in his possession, so he must be able to construct his own. It is usually necessary to begin by making a scale line, preferably at the bottom of the sheet on which the plotting is to be done, and a second one on stiff

*The Geographer's Protractor, formerly obtainable from Thos. Murby & Co., 1 Fleet Lane, London, E.C.4, is no longer made.

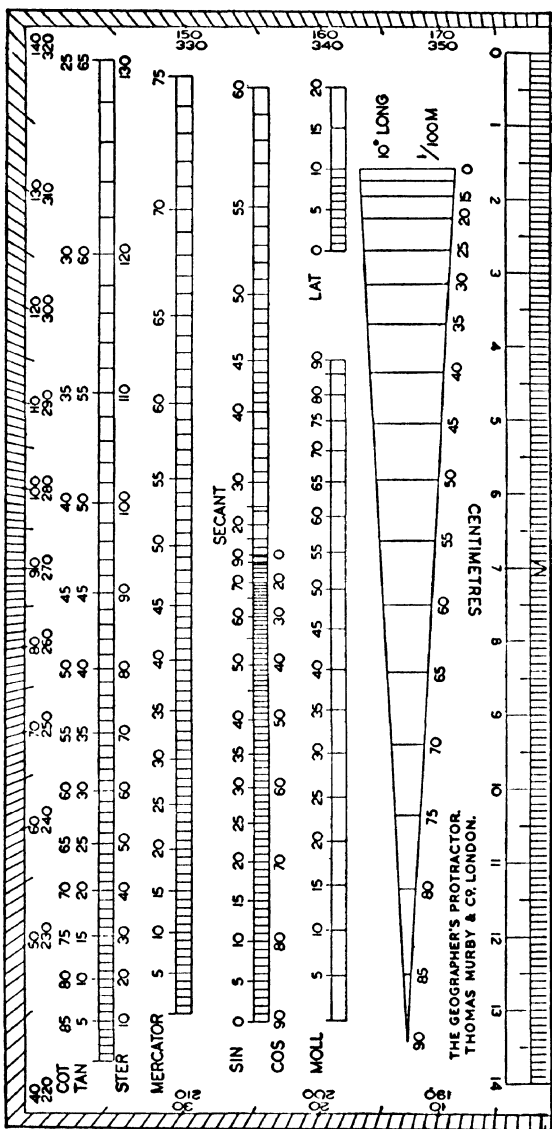

Fig. 5a—Geographer's Protractor, front

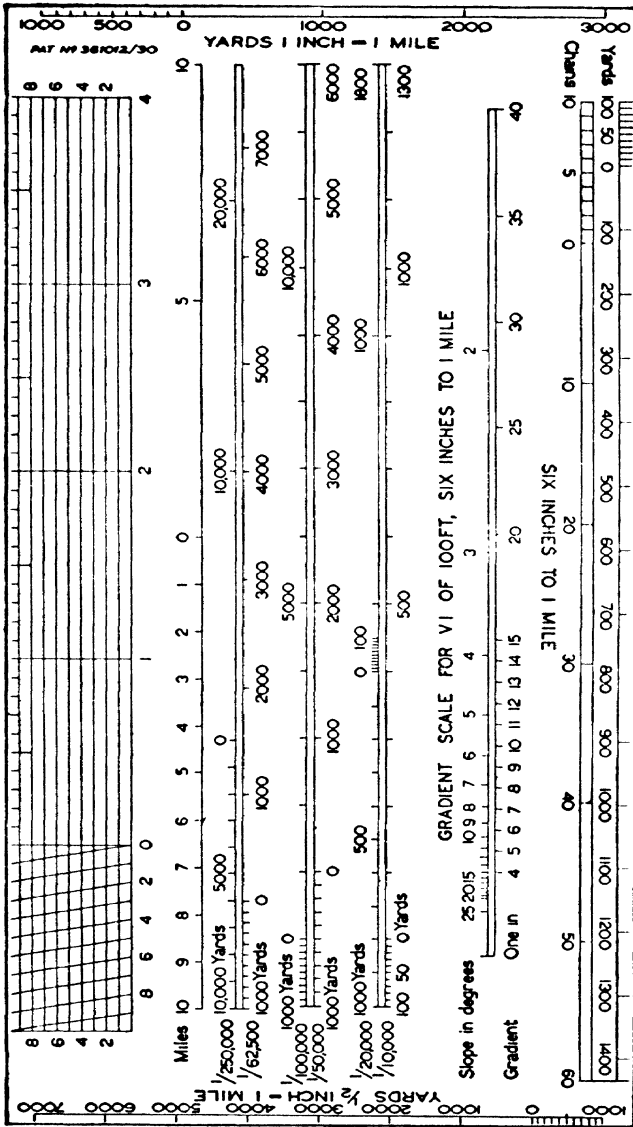

Fig. 5b—Geographer's Protractor, back

paper to be used in the plotting. These will not be the ornate affairs seen on estate plans, but there are one or two points about which it is advisable to be careful. We will suppose that scale lines for the scale of 1 : 5000 are to be made, and that the unit of measurement used in the field is the yard. Our first calculation is as follows:

1 in. on the map is equivalent to 5000 in. on the ground or 416.6 ft. or 138.8 yd. Therefore, 100 yd. on the ground will be shown by $\frac{100}{138.8}$ in. or .72 in.

We could take .7 in. from any good scale with ease, but the hundredths of an inch would not be so simple. It is preferable therefore to go to work thus:

If .72 in. represents 100 yd. then 7.2 in. represents 1000 yd., and we accordingly rule a straight line and mark off 7.2 in. on it by fine transverse ticks. If the inch-scale cannot be placed against the pencil line, then it will be necessary to transfer the 7.2 in. from the scale ruler with a pair of dividers.

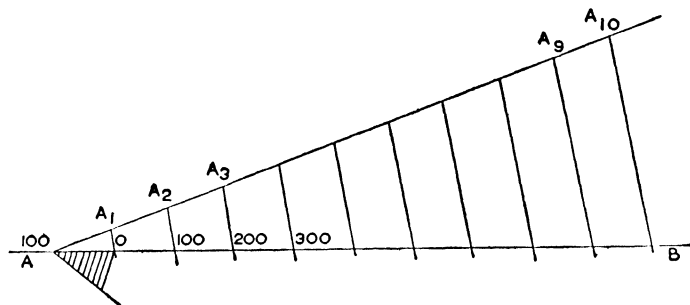

Fig. 5c

We now divide the 7.2 in. or 1000 yd. into tenths by ruling a construction line at a small angle to it, and marking off along this ten equal parts A₁, A₂, A₃, &c. A₁₀ is now joined to B by a straight line and A₉, A₈, &c., are ruled parallel to it, thus dividing AB into 10 equal parts, each representing 100 yd. Since each of these parts is .72 in., we can easily divide them

further to 10 yd. units, and the left-hand section is so divided by another construction line.

The scale line itself is then carefully inked in, the construction lines are rubbed out, and it is numbered, so that the zero is at the end of the first section, to facilitate measurements to the nearest ten yards.

The paper on which the plotting is done is just as important as the pencil and ruler, and it may be said at once that pennies must not be saved on it. "Cartridge" paper is not really good enough for mapping, except for preliminary plottings or temporary work. A very smooth surface is not essential, although the smoothness of the best Bristol board is a pleasure to work on. Smooth hand-made paper of a fair thickness is the best choice, but "hot pressed" machined paper does very well, and where there is not very much detail the "Not" surface, rather rougher than the hot-pressed, takes pencil lines very well.

All paper, and especially machine-rolled paper, is liable to expansion and contraction with the varying humidity of the air, and since it expands more with the grain of the paper than across it, errors of scale in the final map may result. These errors are usually much smaller than will arise from other causes in the type of surveying we are considering, but it is as well to remember, especially in damp tropical regions, that the variation may be as much as 2 per cent, and it may have to be taken into consideration, either by keeping the paper dry when plotting, or even by ruling two scales on the paper, one with the grain and one across it. In general, we may ignore this source of error, though it is a great trial to those whose business it is to turn out really accurate maps.

With these very simple tools the first plotting is done, and beginners must beware of the temptation to work too rapidly and roughly because it is in pencil which will later be rubbed out. Even the conventional signs, such as hachuring for embankments, tree signs, &c., should be done neatly and carefully, so that the inking in can be done

exactly over the pencil lines. The ink should be Indian ink, preferably waterproof, even though the gum arabic and potassium bichromate which is added to it to render it waterproof causes it to be slightly thicker than plain ink.

As to pens, the tendency is to use too fine and springy a mapping nib, which will produce lines varying in thickness. For general work a fairly fine ordinary nib is probably the best to use, and for lettering a broader nib which is not springy enough to spread appreciably under pressure.

A ruling pen is not suitable for plotting, but is invaluable for borders, titles, &c., and needs a little practice before one becomes facile with it.

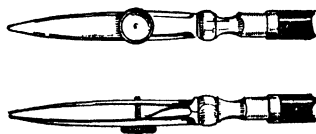

Fig. 6.—A ruling pen is used for borders

Once the detail is all inked in there comes the most tedious part of the map drawing, the lettering, and on this matter it is as well to take a strong line. No one can become expert at lettering without years of practice; therefore it is suggested that some simple form of lettering should be adopted, without attempting to imitate letterpress or high-class draughtsmen's work.

Appendix I gives some advice on the subject of lettering, which therefore claims no further notice here.

The map is now finished, unless colour is to be used, and on this point our advice is perhaps unorthodox, and that is to use colour-wash wherever possible, not merely because it helps to hide blemishes and tends to brighten up the work, but because it can be made to serve instead of lettering or conventional signs, both of which are tedious to do well.

Since we are addressing geologists, who will want to dif-

ferentiate formations, botanists who desire to show ecological provinces, and geographers who wish to bring out special distributions, all of which can only be done satisfactorily by colour, it is perhaps unnecessary to apologize for including a few simple hints on colour-wash, which may be put as follows:

(1) Incline the drawing board so that the colour wash will tend to run down the paper towards the worker and lay it on from the top downwards.

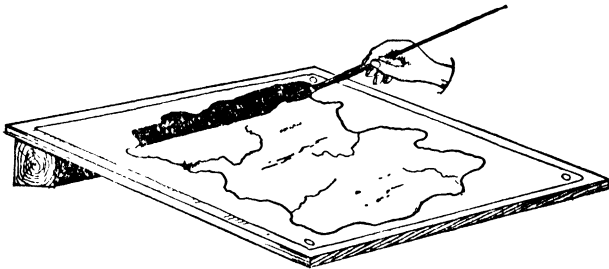

Fig. 7.—Laying on a colour-wash

(2) Use a faint wash; it looks much better than a strong colour; and be careful to mix more than enough, for if it runs out before the work is done, it is impossible to match it again.

(3) Colours vary very much in the degree of fineness of the pigment, pinks and blues and siennas going on smoothly while greens tend to be spotty, and show a grain.

(4) Lay on the colour with a full brush at the top of the work, and lead it downwards, never allowing the free edge to get dry, or there will be a hard line across the wash. When it reaches the bottom the excess of colour can be mopped up with the brush after squeezing it between the fingers.

(5) Never attempt to retouch if the first wash is not satisfactory, no patching will improve it.

Finally, in all plotting it is as well to remember that although no measure of neatness will really compensate for

bad field work, it at least makes the best of it, while good field work most certainly deserves neat presentment. It may not be truly just, but it is nevertheless a fact, that a map is usually judged by its appearance, and not by its faithful and accurate representation of country.

It should be remembered that a map is really a condensed report or description, and just as a neatly typed memorandum calls for more attention than one scribbled on odd sheets of paper, so a neatly finished map claims interest at once from its appearance.

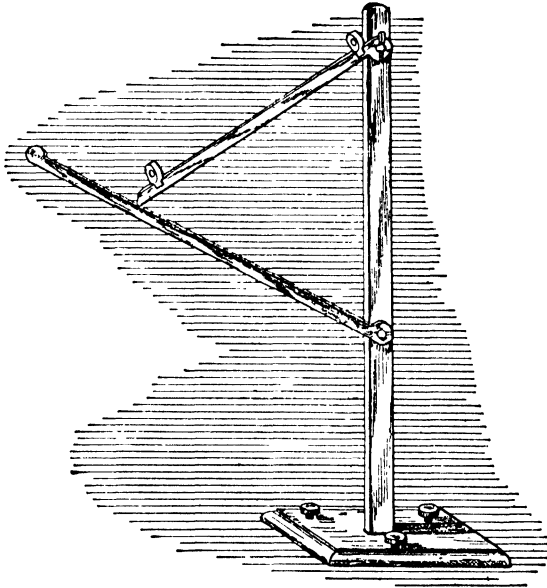

Triquetrum

Chapter III

THE MEASUREMENT OF DISTANCE

DIMENSIO MANVALIS

Digitus Vercia Palmus Dichas Spithama Pes



DIMENSIO PEDALIS



Gradus

Passus simplex

Passus Geometricus

After Apianus, 1534

"The Geometer, how excellent so euer he be, leaning onely to discourse of reason, without practise (yea and that sundrie wayes made) shall fall into manifolde errors, or inextricable Laberinthes."

DIGGES' "Pantometria", 1571.

THE fundamental operation in all surveying is naturally the measurement of length over the ground; and since it is also one of the most tedious, it has been found advisable to devise methods which reduce the labour without affecting the accuracy.

It is not far from the truth to say that a great part of the evolution of surveying has been in the direction of minimizing the trouble of measuring distances; consequently we have quite a large number of methods to choose from, adapted to a variety of circumstance and country. We may achieve any degree of accuracy we please, provided we have the time and patience, from a probable error of one in a million (in the case of a trained party measuring base lines with invar tape), down to mere visual estimation. For the purpose of maps of small areas we shall never need invar tapes, nor shall we often permit ourselves mere guesses, but we shall incline to those methods which are simple, and which involve one, or at most only two, pairs of hands and feet.

All measurement over the surface of the ground involves the repeated laying down of some unit of length, whether it be the length of a pace, the circumference of a bicycle wheel, or the distance between the ends of a steel tape, the only stipulation being that the units shall be ultimately reducible to the common units of length.

But all such distances are measured over the surface of the ground, and we are at once met with the problem of how to deal with slopes. Are we to measure over hill and dale and call that the distance between two points, or shall we attempt to get the horizontal distance? Shall we measure the face of a cliff and call it so many acres of land?

Such problems as these had to be settled in some arbitrary way, and the fundamental convention in surveying is that all distances shall be "reduced to the horizontal", so that the area of all land is the surface projected on to a horizontal plane.

The convention was necessary to avoid worse pitfalls.

Supposing Switzerland were to be smoothed out on a map, it would reach half-way through Germany, and there would be no comparison possible between lengths over the surface and latitudes from the stars. Yet it also involves some curious consequences. If we are touring a hilly district in a car, we shall find that our speedometer totals will always be greater than the distances measured from the map, for we have gone over the ups and downs, while the map measurement has gone straight through all the hills.

Stranger still, an acre of land as sold by the estate agent, will vary as to actual surface, being a true 4840 sq. yd. of surface if it is on a plain, but more than that if on the side of a hill. That it does not make very much difference for the ordinary purposes of life is shown by the following anecdote. A man announced to a friend that he was buying an acre of land for an orchard, and said that he was buying it on a steep slope so as to get more than an acre of surface. The other pointed out that he would not gain because his trees would grow vertically, and the set distances between them would therefore have to be the same as if they were on a plain. The first man immediately decided that he would grow strawberries. The exact amount he would gain by buying in such a position for such a purpose is left to the reader; but it is, in fact, a consideration in places like Switzerland, where the grass is cut for hay on as steep a slope as it will grow upon.

Our immediate purpose is, however, not with these gains of square yards, but with the fact that the map-maker reduces his measurements to their horizontal equivalent, either by holding his chain horizontal, or by subtracting an amount calculated from the degree of slope.

Of the simpler methods of measuring distance, the following are of special value, in that they can be used by one man alone:

Pacing;
Revolutions of a wheel;
Time and rate;

and of these the first and third are of the utmost importance to the amateur surveyor, provided they are used with caution and understanding.

Pacing

The length of a man's natural walking pace is extraordinarily uniform, as may be tested by counting paces along a street block a number of times. It will vary slightly when going up or down hill, or when the walker is carrying a heavy load, or is walking over rough ground, or walking fast, and such variations may have to be taken into account, but the fact remains that the human legs are quite an efficient measuring mechanism.

The pace must be the natural one, but it is curious that as soon as a man begins to count his paces, they immediately become unnatural, and it requires a little practice to pace unconsciously and not deliberately.

It is necessary to know the value of the pace in the units which we use for plotting, otherwise we shall not know the scale of the map. This is found by pacing a measured distance of at least 200 yd. three or four times, and taking the mean of the number of paces for the distance. We can then express the length of one pace in any way we like, but since the yard is the most reasonable unit for plotting on small area maps, it is best to record the pace length as a decimal part of a yard. Thus if 200 yd. took 218 paces, the value of the pace is $\frac{200}{218}$ yd., that is .917 yd. Thereafter any number of paces can be converted to yards by multiplying by the factor. If the whole survey is measured in paces, this multiplying will be avoided by making a scale of paces to begin with, and using that for the plotting throughout. If circumstances demand it, it may be necessary to find the pace factor for slopes, rough ground, &c.

The most tedious part of the pacing is the counting, so that any device which reduces that labour is well worth knowing. It is easy to count only every second step, say every left foot

step, and a little practice enables one to count only every second left foot. This plan reduces the actual counting of figures, but does not really release the mind from concentration, nor is there any way of doing so, unless the distances paced are fairly long, and do not involve frequent stopping for side measurements. In those circumstances a passometer or pedometer may be very useful. This is a small instrument, the size of a watch, hung on the front of the coat, which, by a delicate setting of a pendulum, registers each forward step, and shows the aggregate on a dial. If these instruments were made so that the indicator might readily be reset to zero they would be much more useful, and measurement by pacing would not be the bugbear to surveyors that it is at present. That even this tedium can be endured is evident from the fact that recently a former student, now a District Commissioner in Kenya, sent the author a map of a traverse made by him which involved counting paces for 280 miles.

As to the degree of accuracy to be obtained by pacing, circumstances vary so much that actual figures for special cases will not have much meaning, but it is easily tested by the beginner. It is safe to say that he will be surprised at its accuracy over pavements or hard high roads, which should be not much worse than an error of 1 in 100, but he will probably be a little disappointed at his error over ploughed fields or rough country generally.

Revolutions of a Wheel

Measurement of distance by using a wheel is in theory a much more accurate method than pacing. The specially designed "perambulators" or recording wheels which road surveyors often use will give very good results, but the types of wheel measurement at the disposal of the amateur surveyor cannot pretend to be much more precise than pacing. The use of them on roads or open country is so much less tedious than counting paces, that a word or two must be spared for them, especially as there is no better practice for

a beginner than to do a series of bicycle traverses along roads.

It is easy enough to find the factor of the bicycle wheel by riding or wheeling it over a measured distance, but it must be noted that these will differ slightly, since the weight of a rider effectively decreases the radius of the wheel.

It is necessary to count the revolutions of the wheel, but this can be made fairly easy by tying a little piece of cane, or a springy twig, to the spokes of the front wheel, which will give a distinct twang at each revolution as it passes the forks. Cyclometers are simple little instruments which will do the counting automatically, but unfortunately the ordinary pattern purports to give the distance in miles and quarters on a close scale, so that short distances are not registered at all. There is one pattern which can be read to about 5 yd., and this would be very useful in long traverses.

The great defect in bicycle wheel measurement is that it is much harder to cycle straight than to walk straight, and an error, always positive, due to the curving of the route comes in which must be allowed for. Further, since the unit of one revolution is usually between two and three yards in length, the method is not suitable for short distances.

Time and Rate

For really long distances either by land or water this method is almost the only one available to the amateur or the explorer, and it is the method used from time immemorial for measuring the distance travelled by a ship. Its application to travelling by horse or by caravan or by walking is fairly obvious, the only difficulty being the estimation of the rate, which naturally must be tested over a measured distance whenever possible.

For small area surveys, however, its application is limited in practice to surveying by water, as it is not difficult to keep a fairly uniform rate by boat, whether propelled by hand or motor.

Chaining

This term is a general one for the very ancient process of measuring a length by laying a cord, chain or tape down successively along the survey line. It involves the assistance of a second person besides the surveyor proper, but the amateur surveyor must occasionally resort to this more exact method.

The instrument to be used may be the familiar linen tape for less important work, or the "chain", made of successive bars and links, or the more accurate, but less durable, steel

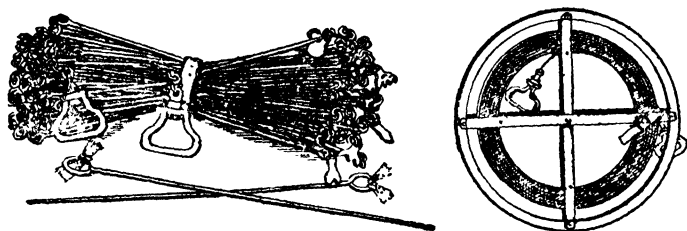

Fig. 8.—Linked chain, arrows and steel band

tape or band. They are all to be obtained in either 66-ft. (chain) or in 100-ft. lengths. Unless the surveying is for the purpose of finding areas, when the chain of 100 links to 66 ft. (10 square chains to the acre) is convenient, the 100-ft. lengths are preferable. Little need be said of the linen tape which, although it is very useful for side measurements or "offsets" from the main lines, is not intended for exact or continuous main line measurements. The linked chain is a professional instrument, and though it has many defects, it will stand a great deal of wear, and is excellent for rough or wooded country, where a steel tape is liable to snap. Its usual construction is a series of stout wire bars connected together by a set of three oval links. They should be of steel, and the links should be brazed, but in the cheaper types soft iron wire is used, and the links are merely bent round. Every tenth link

or foot is marked by a brass "tally", the number of points on the tally giving the number of tens of links or feet from the nearer end. The length from the middle loop or ring between two bars to the next middle ring is 1 link, or 1 ft., as the case may be. The handles are usually of brass, with flattened ends, and the total length is from the outside of one handle to the outside of the other. Even from this brief description of a chain the following points will be appreciated:

(a) The chain is liable to lengthen when under tension, for each of the 500 rings will tend to spread a little.

(b) It is liable to be too short if the links become clogged with grass or stiff mud, or if any of the bars become bent.

(c) It has a definite weight, and so will sag if it is lifted off the ground.

(d) It is only possible to measure full lengths of the chain exactly, odd links are less exact, and parts of a link must be estimated.

Yet even with all these disadvantages, the linked chain is an extraordinarily useful instrument, and if used with precautions is capable of fairly accurate work. The fact that it is liable to be too short or too long may give rise to bad errors, unless it is "standardized" frequently, that is to say, stretched alongside an unused chain or other standard length, and the amount of its error recorded. The error due to sagging when stretched in the air is fairly small compared with other inevitable sources of error, but that and other errors are minimized by stretching the chain always to the same amount of tension: this should be equivalent to 10 or 15 lb. weight, but is of course merely estimated by the chainmen, a firm but not a strong pull being required.

The procedure in chaining is simple enough, yet beginners may take a long time to become at all facile unless they start right, and it is quite possible to get the chain into an ignoble tangle. The chain is delivered as an hour-glass shaped bundle tied round the middle with a cord or strap. This is undone, and, grasping the two handles in the left hand and unwinding

two or three links, the rest of the bundle is held in the right hand, and hurled up in the air and away from the holder: it should unfold itself in the air free from tangles. In doing up the chain the middle two links are held, and successive pairs of links towards the ends are folded up alongside them with the right hand, the left hand grasping the bundle round its waist, and turning each pair of bars slightly so that it takes the shape of a sheaf of corn. With each chain there should be ten long wire "arrows" or pins, which are used to mark the ends of the chain. These are all taken by the front man, or "leader", who marches off with one end of the chain. The rear man, or "follower", holds his handle pressed against the starting-point of the line, and when the leader turns to face him, holding his end of the chain close to the ground and to the side of him, the follower can see the other end of the line, marked by a pole or stake, and can set the leader "on line". When he is on line the leader pulls at what he considers the right tension, and marks his end with the first arrow. With a little practice this can be done with the same hand, by grasping the arrow and the end of the chain together, as in the figure. When the first length is marked the chain is dragged along for the next length, the follower now placing his handle against the arrow for the measurement, and picking it up when he goes forward again. When the tenth chain is measured, the leader has no more arrows left, and the follower hands over what he has picked up. This formal handing over of arrows at the tenth chain appears at first sight to be a clumsy way of counting, but experience has shown it to be necessary. Some years ago the experiment was made with a large class of students of measuring about 40 chains without the arrows, and the count was wrong in over 30 per cent of the pairs.

In chaining up and down slopes it is necessary to use some method which will reduce the superficial distance to the horizontal. It is as well to realize that errors due to neglect of this are not serious except on sharp gradients. For a

gradient of 1 in 7 which is taken as a standard for marking hills as "steep" on the O.S. maps the error would be less than 2 per cent. A rough and ready allowance for slope will usually suffice for small area surveys. This allowance can be made, either by estimating the gradient and applying a correction from a simple table such as the following, or by holding the chain in the air on an estimated horizontal line when on slopes. If the slope is such as to make the end of the chain

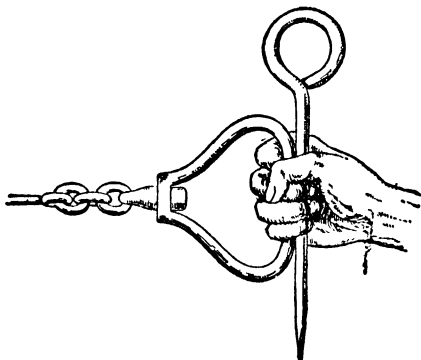

Fig. 9

come much above the arrow, a plumb-bob, or a stone on a piece of cord, should be suspended from it to ensure that it is over the mark.

TABLE OF ALLOWANCES FOR SLOPES

Slope in Degrees	Gradient	Percentage Allowance always minus
5	1 in 12	0.5
7½	1 in 8	1.0
10	1 in 6	1.5
12	1 in 5	2
14	1 in 4	3
16	1 in 3½	4
18	1 in 3	5
20	1 in 2½	6
27	1 in 2	11

With a little practice chaining can be done quite rapidly, and indeed the professional surveyor employs unskilled men for the work and merely supervises it. But various sources of error are creeping in all the time, and we must consider these for a moment. Errors can be divided into those which are compensating, that is to say, sometimes positive and sometimes negative, tending to neutralize each other, and those which are cumulative or additive, the error being always either positive or negative and increasing all the time.

Thus if the chain happens to be 100.5 ft. instead of 100 ft. in length, the error will be cumulative, the half-foot error being repeated every time the chain is laid down. Note that because the chain is too long the resultant figures will be too short, that is, the error is negative, for the chain is laid down ten times, the apparent length is 1000 ft., but the real length is 1005 ft. The initial error of .5 ft. has therefore to be *added* each time the chain is laid. Other cumulative errors are those due to measuring along slopes, or getting off line, so that a longer route is measured than the straight line between the end marks or stations.

On the other hand, the fact that the arrows may not be truly upright when the chain is stretched between them will give a compensating error, for they will tend to lean as often in one direction as in the other.

It will be necessary to deal with errors in more detail at a later stage, and for the moment we may say that average chaining should not give an error greater than 1 in 500, while with practice and in easy country it may be as little as 1 in 1000. Such errors are quite reasonable for the greater number of small area surveys of the type with which this book deals.

For such things as base lines, or for important traverses, a greater degree of accuracy may be required, and then recourse is had to the steel tape. This stretches very little under tension, it can be graduated to single feet, and it is altogether a more precise instrument. If the iron arrows are replaced by pegs on which a pencil mark is made, and if

special attention is paid to allowances for slope, an accuracy of 1 in 2000 is easily attained.

Chaining is a comparatively simple business in open country, though it is very much slower than pacing, and for long distances may become decidedly tedious. In country which is wooded or has other obstacles, chaining may be both difficult and interesting, and certain methods by which such obstacles can be circumvented must be mentioned. If the

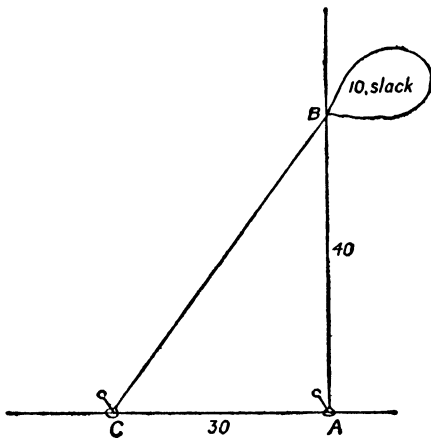

Fig. 10

survey line runs through a tree or other small obstacle the line is continued to the side of it by two short offsets, the necessary right angles being estimated by eye. But if the obstacle is much wider, such as a large pond, there are several ways of going to work. One may again offset the line to one side as in the case of the tree, but here it will not be safe to guess the three successive right angles that are required, and they must be set out with the chain. This is done by using the Pythagorean theorem, by which a triangle with sides in the ratios of 3 : 4 : 5 must be right-angled. From the point A in fig. 10, whence the perpendicular is to be

set out, 30 links of the chain are measured back to C and arrows are firmly fixed at A and C, over which the end handles of the chain are placed. Then the fortieth link from A and the fiftieth from C are held together, leaving a slack loop of 10 links over: the two lengths are pulled equally taut, and the point B thus found will complete the right-angled triangle. An interesting test of the accuracy in setting out right angles on the ground in this way may be made by setting out a full square with each side one chain in length. It involves setting out three successive right angles by the

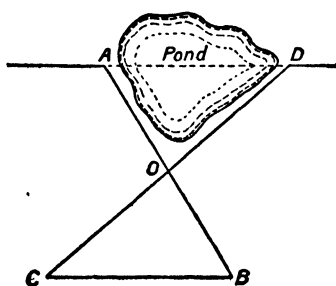

Fig. 11

In fig. 11 the chaining has gone on up to point A, when the obstacle is met. An oblique line AB is measured, and a peg or arrow is left at its midway point O. The line DO is then measured and continued for an equal length to C. It is clear that the triangles AOD and BOC are similar, and that by chaining CB we are finding the length AD across the pond, which is what we require.

There are various other ways of using right angles and similar triangles to measure inaccessible lengths, but the only one which we need quote here is a method of finding the width of a river when the chain cannot be stretched across it. In fig. 12 we have two marks A and B on either side of the river, and we require to find the length of AB. Set out a

3 : 4 : 5 rule, at the end of which the last point should coincide with the starting-point. With reasonable care it will only be an inch or so in error.

Setting off the line with right angles in this way will, however, take some time, and it may be simpler to adopt another method, which employs the principle of similar triangles.

right angle at A and measure AC, leaving a pole at O, its midway point. At C set out another right angle, and measure along CD until the pole at O is in line with the mark B. We have, then, set out two similar triangles, and the length CD,

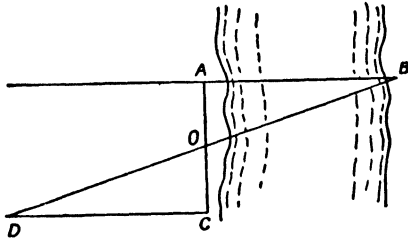
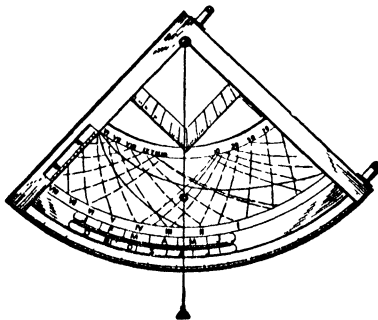

Fig. 12

which we have just measured, is the same as AB, which we require.

The entering up of chain measurements in a notebook, or "booking", is done in various ways, some of which will be mentioned later on. It is sufficient at this point to note that for small operations, such as chaining a small field, measuring garden paths, &c., the best way is to draw the survey lines in the notebook and write the lengths alongside them. For larger areas this becomes impossible.



Quadrant

Chapter IV

THE SURVEY OF SIMPLE ENCLOSED AREAS

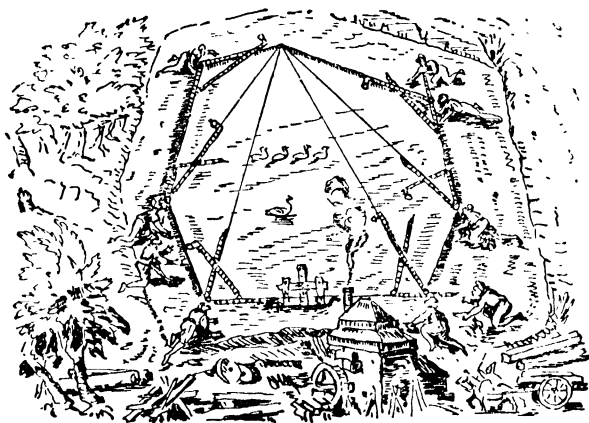

After Bramer, 1664

“Since the Business is of itself a Thing so natural and easy one would wonder, after so much learned Bustle as the Mathematicians have made about it, that they should have more perplexed and obscured than promoted the Knowledge of that useful and entertaining Art amongst the Generality of Mankind.”

CHARLES LEADBETTER, 1737.

WE have now learned how to make measurements of distance in the field, and it would seem that the next step would be to proceed to measurements of direction, for distance and direction are the two fundamental components of practically all surveying. But it happens that for simple cases of fields or small areas we can do without direction measurements, or rather achieve them indirectly by means of distance measurements alone: the method is a common practice with land surveyors, and since it can be applied quite well to special cases which may crop up in geographical or geological work, it must have a place in this book.

If we measure the four sides of a field we cannot plot it without a knowledge of the angles between the sides; but if we split up the quadrilateral into two triangles, by measuring a diagonal or "tie-line", we can plot each triangle simply enough. The diagonal is set out to scale, and from each end of it arcs are drawn with radius equal to the corresponding side, and the intersection of the two arcs will complete the triangle to scale. In this way we can survey any area by splitting it up into triangles, and measuring all three sides of each triangle.

There are certain limits to the method in practice, however, and one or two precautions to be taken. The triangles must be of suitable shape, or "well-conditioned", for if there is great disparity in the size of the angles we shall have the construction arcs crossing each other awkwardly, so that a small error either in the field measurements or in plotting will make a great difference to the shape of the triangle. Fig. 13 shows two ill-conditioned triangles and one well-conditioned. Also there is no check on the shape of the triangle if we merely measure its three sides, yet the easy checking of all work done is one of the maxims of all surveying. If, in any triangle, we measure a fourth line from a known point on one side of the triangle to a known point on a second side, we can see if that measurement fits the triangle when it is plotted; if it does

we know that our work is correct; if it does not, we know there is a mistake somewhere, though we do not know where. It is convenient in this method of surveying to call such lines "check lines", while the ordinary lines dividing the area into triangles may be called "tie lines". Both lines, however, may be made to serve as survey lines from which to measure detail by offsets at right angles to the lines.

Such is the general principle of what is known as Simple Chain Survey; but the practice is not always simple. We

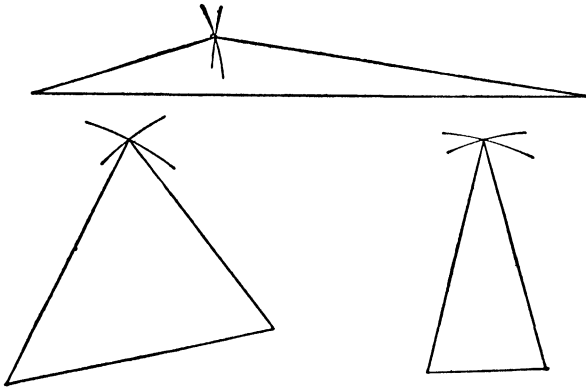

Fig. 13

will now follow out a moderately complex survey of a set of fields, detailing the procedure, and pointing out the difficulties that may arise. Fig. 14 shows the area to be surveyed, a set of four fields, intersected by a stream and also by a cart-track, and with hedges as boundaries, except where the stream acts as such.

We cannot measure along the middle line of the hedges, so that our survey lines will not be the actual boundaries, and the difference will have to be allowed for, by side measurements called offsets, at right angles to the survey lines. If the boundary is a straight line only two offsets are required,

but if it is irregular the number of offsets will have to be increased, the actual number depending on how irregular the boundary is. Every offset requires two figures, first its position on the main survey line, and second, the length of the offset itself.

The system will be recognized as that of rectangular coordinates, the position of a point being known by a distance

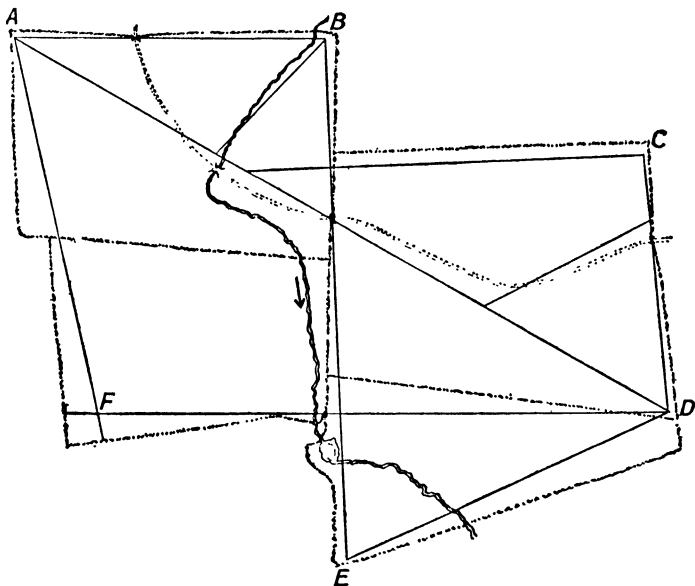

Fig 14.—Layout of triangles for a simple chain survey

along the survey line and a second distance along a line perpendicular to it, that is, the offset.

The right angle for the offset measurement is always measured by eye, for although instruments such as a box-square may be used to give an accurate perpendicular, it is best to be able to do without special instruments of this kind.

This means that offsets must not be too long, since we cannot trust our estimation of a right angle in the field. How

long it is permissible for an offset to be depends on variables such as the expertness of the surveyor, the scale of the map (i.e. the plottable error), the nature of the detail, &c.

Fig. 15 shows how an error of a given amount in a set of offsets gives only a negligible error in a short but an intolerable one in a long offset. When detail is too far off for an offset, it is "cut in" by an extra triangle as shown in the same figure.

The practice of simple chain surveying is an art rather than a science, but a few general principles may be set down as a guide.

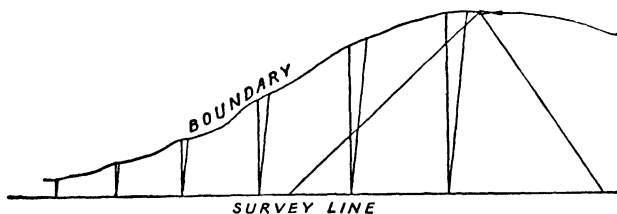

Fig. 15.—The effect of a slight error on short and long offsets: gate cut in by a subsidiary triangle

The first operation is to divide up the area into triangles, setting up marks or station rods at the apexes. To avoid extra labour and to minimize error, there should be as few triangles as possible, and, as a corollary to that, the lines should be as long as possible. It is advisable to have at least one line running the whole length of the area, an ideal which cannot, however, be realized over very large areas or hilly country, since one end of each line must be visible from the other.

It is an economy of time if all or most of the tie lines can be made to serve as survey lines as well as for picking up detail.

The "lay-out" of the lines is the most difficult part of the work, and some time spent in walking over the area selecting suitable positions for the stations is always worth while.

In the fields shown in the figure we will assume no special obstacles to a "lay-out", and see why the lines were chosen as drawn. The surveyor first looked for a survey line which would cross the whole area and selected AD, placing it so that it would pass near enough to the stream in places to act there as a survey line, although for the most part it is really a "tie line" for the various triangles built up on it. He then set out these triangles, running the sides close to the boundaries of the fields where possible. It will be seen that he covered the greater part of the area with three main triangles, that where boundaries were irregular he followed them fairly closely and where straight he was content with fixing only two points.

The check lines in each case were selected so as to run near some detail, stream or fence, in order to permit offsets to them and thus do double duty. The figure showing the lay-out is self-explanatory, except that the surveyor used an unusual way of fixing the two boundaries near station F, by continuing the lines AF and DF to the boundaries. Neither of these are offsets, but since both boundaries are straight they need only one other offset each, where the lines approach them, to be accurately fixed.

Nearly all estate plans are made by this method, which only breaks down where there are too many hills or too much wood to allow reasonably long lines to be run.

If the explanation of the operation has been at all successful, the field scientist should regard it as an excellent method for small area maps and plans. Thus the archæologist would use no other for plans of ancient earth works, the botanist for fairly well defined plant association patches, the geologist for small outcrops such as volcanic plugs or patches of gravel, or anything which has a more or less closed outline. Except in the case of the archæologist the outlines will be vague enough to permit of pacing instead of any more exact method. That pacing will give satisfactory results is proved by the fact that generations of the author's students have surveyed a

public park in Cambridge in this way, and made reasonable comparisons of their work with the Ordnance Survey maps of the same scale. To make it more interesting, many carry out the survey by pacing in such a way that none of the many users of the park is in the least aware of the fact, for it is easy to choose trees, posts, &c., as station marks, and the

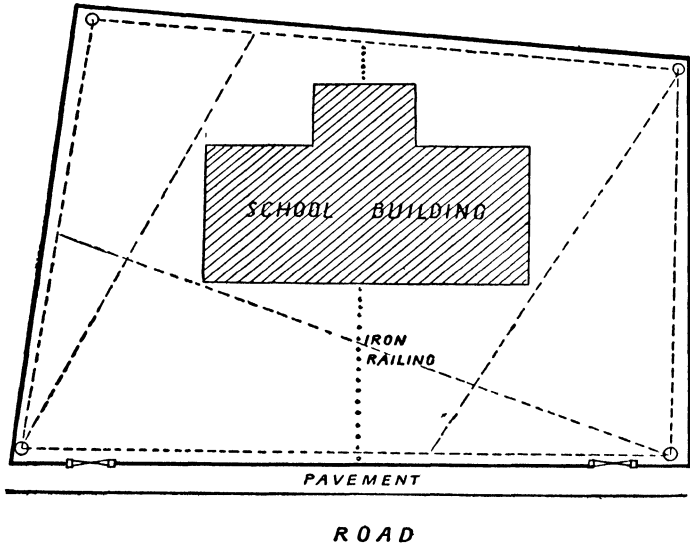

Fig. 16.—Layout of Survey Lines for a School Playground

only part of the work which is then likely to disclose a purpose in the surveyor's walking is the necessity to book his figures.

In such work the simplest method of booking is to make a rough sketch of the area, putting in the survey lines and writing the distances over them. Unless the boundaries are so irregular as to require a large number of offsets the plan should not be too crowded with figures.

We will close the chapter with a case which will appeal to those who wish to make a plan of their school playground,

and find that the buildings themselves apparently prevent the use of the method.

In the figure a quadrilateral playground is measured as to its four sides simply enough, but because of the building neither of the diagonals can be used. However, if the three tie lines shown are measured, just clearing the corners of the building, each will fix its respective angle as to shape, and part of each will serve as a check line for another triangle. A fourth line could be used as a check on the others. It is quite certain that a plan of a city playground done in that way would be more accurate than one in which the angles had been fixed by prismatic compass, for the maze of invisible iron pipes, &c., leading to the building would affect the compass disastrously.

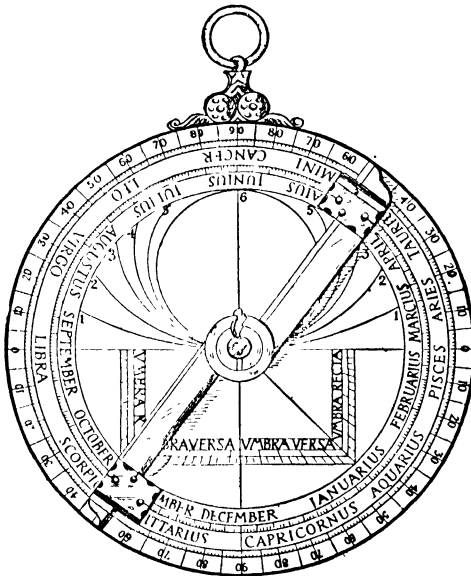

Astrolabe

Chapter V

MEASUREMENT OF DIRECTION: THE COMPASS

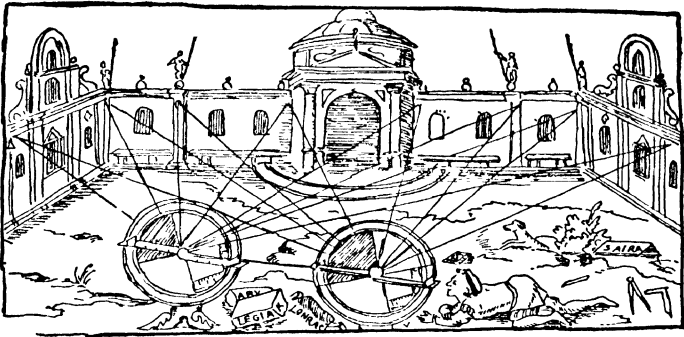

After Gemma Frisius, 1584

"The Magnes stone hath so rare a property impressed through the influence of the heavens, as by onely touching the point of the Needle, hanged on his perfect Centre of Counterpoize, it deliuereth a vertue which presently turneth the Needle to the Meridian, but not so exactly, but that in most places of the world, it hath a certain variation or difference."

DIGGES' "Pantometria", 1571.

AS explained in the last chapter no survey can be done without measuring direction as well as distance, although for small areas directions, i.e. angles, may be achieved by linear measurement of the three sides of a triangle.

It is hardly surprising, therefore, that if any one instrument were to be picked out as essential for rough mapping, it would be the compass, which is still, in one form or another, the guide of the navigator and, though scorned by the precise surveyor armed with a theodolite, still the sine qua non of the explorer's outfit.

A great part of the world as drawn in our atlases is still based on compass surveys of one kind or another, and, in spite of its lack of precision, the compass remains the most useful instrument for rapid surveys of a reconnaissance character. To the map-maker who must travel light and work single handed, and who wishes to map small areas, the prismatic compass is of enormous value.

The ordinary compass to be bought for a few shillings is of little use in surveying, for one cannot sight it on to an object with any accuracy. The prismatic compass, a much more expensive instrument, owes its name to the use of a reflecting prism which enables the user to read the bearing on the compass card at the same time as he sights the object whose bearing he requires.

Its construction is simple, but must be clearly understood if the instrument is to be used intelligently. The "needle" itself consists of an ordinary steel magnet fastened to the under side of a graduated card, the whole being suspended on a metal pin by a cap in its centre. The cap contains a "jewel", a hard stone hollowed to fit the pin on which it rests. The "jewel" will not wear, but the metal pin will, so a mechanism is provided to lift the card off the pin when the instrument is not in use. The sighting arrangement consists of a peep-sight at one side of the box containing the compass card, and a vane at the opposite side, so that on looking

through the sight the upright wire of the vane can be brought into line with any object. In order to be able to read the compass card at the same time, a prism is placed in the line of sight (actually as part of the peep-sight), which reflects the card below it through the sight. Since this reflection turns the figures on the card mirror-wise, these figures have to be printed mirror-wise, so that they can be read the right way

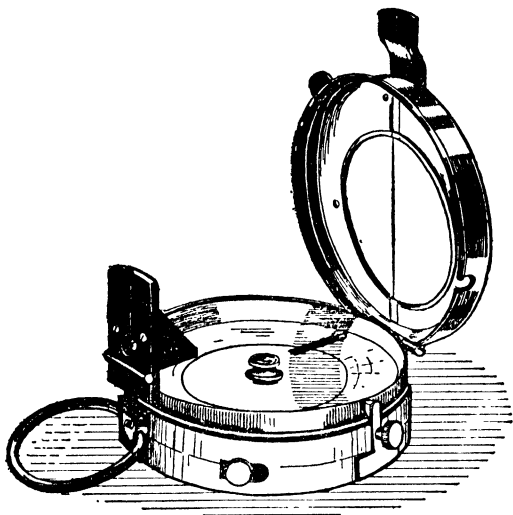

Fig. 17.—Prismatic Compass, Military Pattern

round. Further, as the figures on the card are small, the prism is made to act as a magnifying lens by having a curved base. This introduces focus, so a mechanism for raising or lowering the prism is provided to focus the figures to suit the eyes of the user.

On sighting an object, such as a church spire, the instrument is held so that the wire of the vane coincides with the image of the spire. At the lower part of the field of view the figures on the card appear, and there will be an apparent

fusion of the three images, the spire, the vane, and the figures on the card. Fig. 18 shows the field of view in a diagrammatic way. It is easy to see which figure the wire of the vane coincides with when the card has come to rest, and that will be the magnetic bearing of the church spire.

Actually the eye is being asked to do an impossible thing, to focus a distant spire, a vane 2 in. away and the image of a card all at the same time. The human eye can, however, rapidly accommodate itself to different distances, and what is done in this case is that the eye first focuses the spire clearly, and a rather fuzzy wire is directed over it; the eye then focuses the wire, the spire then becoming slightly blurred, and follows the wire down to the figures, which, being approximately the same distance away as the wire and focused by a lens, are equally distinct. A certain amount of practice is necessary before compass bearings can be taken rapidly and carefully.

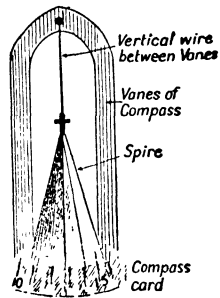

Fig. 18

Another difficulty arises from the fact that the card is swinging, and if the pivot is in good order, it takes some time to come to rest. To enable the user to bring it more quickly to rest, a small "brake" or damper is attached to the front end of the compass box. If this damper is pressed when the card is in the middle of its swing the card is stopped, and when released the swings are smaller. If the pivot is a very good one, the swings may continue for a long time, as much as 30 sec., and it is not at all easy to keep the vane on the object and the instrument steady for so long a time. It is theoretically possible to take the mean of three readings, and deduce what the final reading would be when it did stop, but in practice this is not at all easy, and it is better to rest such a sensitive compass on a 5-ft. stick, or on a tripod, and let it practically cease swinging before taking the reading. If used

without such a support, the compass must be held in both hands, and the elbows pressed to the sides while taking the sight, or it will be difficult to keep the instrument steady. It is still better to lie on the ground. A stick cut to eye-height to rest the instrument on is the best temporary aid of all.

The errors of a prismatic compass fall into two categories, those inherent in the instrument itself and "personal" to it, and those due to external influences.

Taking the latter first, we know that iron or other magnetic material near a compass will affect it, and that it is useless to take bearings near iron objects, such as gates, bicycles or motor-cars. But often enough the "local iron", as it is called, is not visible, for it may be an underground pipe or a body of iron ore. In general there is an element of uncertainty as to the effect of local influences, which can only be checked by taking more than one bearing of a line. Again, the direction of magnetic north is constantly changing, and there are even daily aberrations. These latter may be as much as a third of a degree, but they cannot be allowed for, and we must realize that for this reason alone we cannot expect an accuracy of actual minutes.

The errors individual to the instrument are those due to such things as the pivot not being in line with the peep-sight and vane, inaccurate graduations on the card, &c. These can rarely amount to very much, and, except with a large and sensitive instrument, it is not worth finding their amount and allowing for them.

Finally, there are errors personal to the user of the instrument, such as inclining the instrument when taking a bearing, reading it before it has stopped swinging, &c.

Considering the sum of the errors due to these different causes, it is unreasonable to expect an accuracy in any bearing of less than a quarter degree, and that indeed is good work. On the other hand, provided there is no local influence, all readings should be closer than one degree, and in a long series of

bearings an average accuracy of half a degree should be possible.

To a man accustomed to theodolites and sextants, reading his angles to a single minute or less, this seems a prodigious inexactitude, but in practice compass bearings have a certain amount of compensation in their errors, and can be relied upon in circumstances where one would not trust a more accurate instrument. For instance, a traverse with a theodolite is made by measuring the angle between successive lines, and it is easy to see from the figure that any one error will be amplified as the traverse proceeds. With the compass,

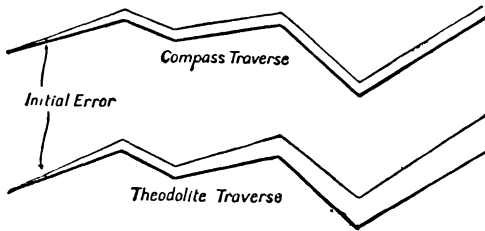

Fig. 19.—Thick lines are true traverse, thin lines the result of an initial and similar error

however, the direction of each line is referred to the magnetic north each time, and any error affects only the line it belongs to, as shown in fig. 19, and does not accumulate.

Sufficient has been said to show that the prismatic compass, though not an accurate instrument, is capable of very useful work, and deserves a better reputation than it has with those surveyors who regard precision as a fetish to be worshipped at all times.

Compass Sketch Surveys

The military surveyor, who has usually been ahead of the civilian in the art of map-making, has a useful term for a simple method of surveying by compass, namely, the "Compass Sketch".

Compass sketching simply consists of fixing by means of bearings a number of points which are fairly correctly placed

relatively to each other, and sketching in by eye any detail near those points so fixed. The method is really similar in principle to the Triangulation which forms the framework of all accurate surveys, but it is more accurately described as the fixing of points by Intersections and Resections, as will be seen when the procedure is outlined.

The instruments required are a prismatic compass, a sketching board, and a protractor for plotting the bearings. The paper should be a good quality thick section paper, ruled "feint" in squares, the lines serving as meridian lines from which to measure the bearings, and it is fixed firmly to the board, since the bearings must be plotted in the field. A sharp pencil, H or 2H, and a rubber complete the outfit.

We will suppose the piece of country to be mapped is a few square miles in area, too large, in fact, for a reasonable sketch map by eye alone.

Any part of the area will do to begin on, but if it is towards the centre the procedure is a little simpler. Here a "baseline" is laid out, from which the first intersections can be made. Choosing a point whence a fair number of prominent objects are visible as one end of our base, we take bearings to these objects, and plot them with the protractor; these become a series of lines or rays radiating from a point on the paper, each being labelled temporarily. A bearing is also taken to the point selected for the other end of the base. The question of how long the base should be depends chiefly upon the scale selected, and should not be shorter, when plotted, than 3 in. The sheet will now look like fig. 20(a).

The base is now measured by pacing, and the other end plotted according to the scale chosen. Bearings to the same objects are then taken and plotted, the intersection of the rays being the positions of the points. The rays themselves can now be rubbed out, and suitable conventional signs, or else points surrounded by circles, left to mark the position. Fig. 20(b) illustrates the sheet while this rubbing out and clearing up is being done. At this stage it will be noticed that some

of the intersections are so oblique as to be rather untrustworthy. These will be left with rays uncleaned until further rays are drawn to them to make more trustworthy intersections. Each of the points so fixed now provides a nucleus,

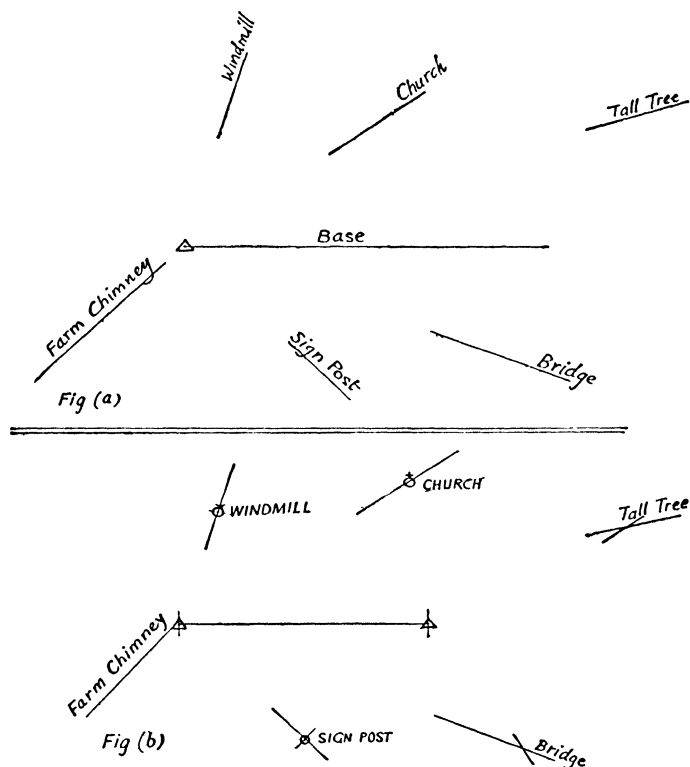

Fig. 20.—Compass Sketch

reasonably accurate, round which to sketch the detail near it. The number of points required depends upon the amount of detail, and the degree of precision demanded.

We must not have any exaggerated ideas about the accuracy of these intersections. If we take a good intersection, where

the rays cross each other more or less at right angles, we may analyse its error thus. Assuming for the moment that each of the rays is about 600 yd. in length, and remembering that each of the bearings has a probable error of, say, half a degree on either side of the correct bearing, we can calculate the area covered by the "point" of intersection, which has now become a quadrilateral, as in the figure. The subtense of an angle of one degree is about 1 in 60, that is, about 10 yd. in 600, so that the quadrilateral covers about 100 sq. yd., and we should say that our point has a possible error of 5 yd.

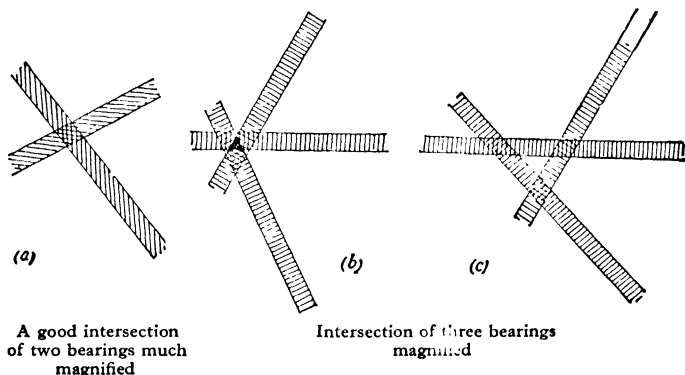

Fig. 21

Before we become impatient with a method which can give such errors, we must remind ourselves that we are setting out to map control points for sketching by eye, which are very much better than could be got by estimation alone. We cannot avoid a possible error of about half a degree in each bearing without taking larger instruments and a much longer time, but we can avoid blunders by improving on the single intersection of two rays by taking a third bearing from another point. Such a three-ray intersection when given its proper interpretation will appear as in one of the types of fig. 21.

In the better of the two we have apparently reduced our area of uncertainty to a small triangle, but a little reflection

will show that this is not necessarily true, though we have confirmed in general the correctness of the first intersection. In the worse case we have now three possible "areas" for the intersection, but if these are far apart it really means that one of the three rays was in error. If the discrepancy is really gross then there is nothing left for it but to take a fourth bearing from yet another point, which will prove which of the three possible intersections was the most probable.

The longer the rays the greater will be the area of uncertainty for an intersection, and it is clear that in any three-ray intersection a certain amount of preference should be given to the shorter ray.

Circumstances and the conscience of the mapper will usually settle what degree of error is tolerable, and it is unprofitable to consider further what niceties might be introduced, for we are considering a rapid method of mapping and must therefore be prepared to sacrifice accuracy to some extent.

The discussion has, however, disclosed a point of great importance, namely, that each point fixed will have a slightly different order of accuracy, clearly shown by the nature of the intersections fixing it. It will be as well therefore to note this before rubbing out the rays which provided the point, and a simple convention for this purpose is suggested. A satisfactory point, that is, when the rays practically pass through one point, is called First Class, and is denoted by a dot enclosed by a triangle Δ . A second class point is one in which the three rays have not intersected exactly, but have not missed so badly as to require further work on it; this is marked by a dot, ringed by a small circle \odot . Still more unsatisfactory points are not classed at all, and are left with their original rays pointing out the danger of using them as control points except in urgent necessity.

The two ends of the base are first-class points since their distance apart has been measured, and it is equally obvious that a bearing plotted from a second-class point can never be

trusted to give a first-class point. Yet to get a three-ray intersection at all we must visit three first-class points, whereas we have only two, the base stations.

This difficulty is surmounted in one of two ways. If we take extra care with our bearings from the base and select the "best-conditioned" intersection given by these, we can call it a first-class point, and make it our third station. Or, if we consider that procedure too risky, we can measure the distance to a third point, which will confirm the intersection or cast doubt upon it. The point in fact becomes a three-ray intersection thereby, since it is fixed by two bearings and the arc of a circle of radius equal to the measured distance.

Having fixed a certain number of control points by intersection, the sketcher now proceeds to go to such parts of his area as he wishes to fill in with detail, and fixes his own position by "resection" from the leading points. The method and its value can best be shown by supposing that he decides to follow up the stream near the base, and plot that in detail first. Having sketched in the stream from the base as far as he feels he can trust his estimation of distance and direction, he walks down the stream beyond his plotting, and chooses a point for resection. This will be where he can see two or preferably three of his control points. He takes the bearings of these. He cannot plot these bearings from his own position, because he does not know where he is; but his bearing from any object is 180° different from the bearing of the object from him, so he can easily turn bearings *to* into bearings *from*. He therefore turns them into "back-bearings", as they are called, by adding 180° : a forward bearing of 10° is a "back" bearing of 190° , of 95° is 275° , of 310° is 490° or 130° beyond the full circle, and so on. The back-bearings so obtained he now plots with his protractor from the respective objects, and their intersection gives him his position, from which he then proceeds to sketch in the adjacent section of his stream. If the position so fixed were close by a high and visible object, such as a tall tree, he could mark it in, so that it may be added

to his control points; if not, the point is rubbed out again after he has used it.

It should be clear that a three-ray "resection" is nearly as good as a three-ray intersection; not quite so good, perhaps, since a local influence at the point may affect all three bearings, yet allow them to intersect at a point. For rather indefinite detail such as a river bank, however, it is not worth while taking three back bearings unless all are very distant, or there is some other reason for doubting two alone.

Proceeding in this way, he sketches in all the detail he requires, though as he gets farther away from his original base he may find he needs new control points, which he fixes by intersections as before, rays to new objects being drawn as requisite from any first-class point fixed by resection.

With a little practice, the sketcher will develop a number of devices by which the accuracy and rapidity of his work are increased. For instance, he will automatically hold his sketching board, when putting in detail, so that lines on the board are parallel to lines in reality, known as the setting or orientation of the board. Also, he will recognize that much of the detail can be sketched in without actually visiting it, provided that it is not far from one of his control points.

It pays to be comfortable while plotting in the field, and this means having a fairly large sketching board, not less than 15 in. by 12 in. in any case, good paper and a fairly large rectangular protractor. It is, of course, permissible to take all the bearings from a station before sitting down to plot them provided they are noted down in such a way as to avoid mistaking one for another. For sketching in the detail, however, as already noted, one must face the detail being drawn and keep the board "set". An economy of pencil ruling must be used so as to reduce the rubbing out and obscuring of detail already drawn: thus, a part only of a ray need be drawn, somewhere in the vicinity of where the intersection is likely to be and not all the way from the station of origin. The temporary labelling of rays also demands some

ingenuity, and the mapper soon develops a thorough dislike for telegraph posts, which are so beautifully prominent as marks yet so identical that they are easily mistaken one for another. It is difficulties such as these, however, which make the work interesting and exclude that element of monotony which may come in more precise work, where the same operation (e.g. with a theodolite) is repeated over and over again.

Compass sketching is remotely akin to plane-table surveying and, like it, it has one very great advantage in that the

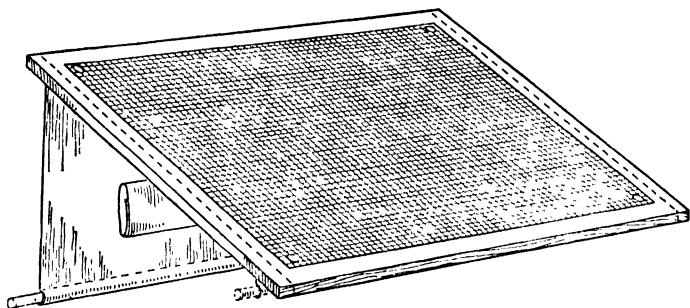

Fig. 22.—Compass Sketching Board with Waterproof Cover

map is drawn in the field and not compiled in a drawing office from notes made in the field. Although really neat drawing is difficult in the open, away from a firm table and large rulers and scales, there is a great gain in that the final map cannot include what may be called blunders or mistakes (as distinct from errors), such as placing a house on the wrong side of a road or putting in a curve of a stream in the wrong direction, simply because the mapper is looking at the objects while he sketches them in. Such mistakes are easily made either when entering up field notes or interpreting them afterwards when plotting the map, and most map-making establishments have classic instances of this type of blunder within their experience.

All this eulogy of an admittedly rough and ready form of mapping would be fulsome without some reference to the type of work suited to it.

In general, one may say that it is fitted for covering an area as contrasted with the fitness of the traverse method for surveying routes, and that it must really be classed as a reconnaissance method. It is, combined with traversing, the only practical method for the explorer who has neither time nor transport for larger instruments, and for that reason it is less suited to an already well mapped country than to undeveloped areas.

Even in our own country there is detail which has not been, or could not be, mapped by the Ordnance Survey, which, being fairly indefinite in itself is best, or at least most rapidly, surveyed by some modification of the compass sketch. For instance, the distribution of sand-dunes, a most heart-breaking job by any but a graphic method, or of glacial erratics or of sporadic moraines. The positions of trees in a park or of tufts of self-sown tussock on a mud flat, or of heather on a moor, are all items which may require mapping, and which lend themselves to this method.

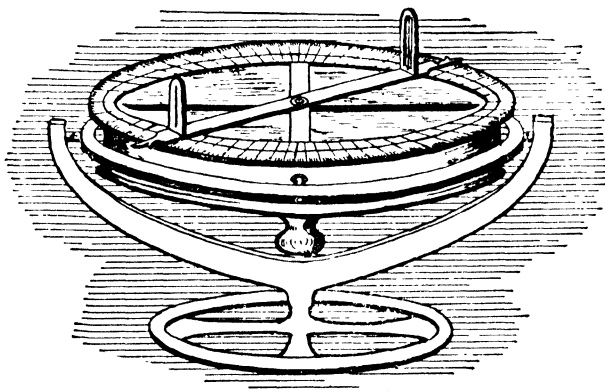

Compass, 1646

Chapter VI

THE COMPASS TRAVERSE



After Aaron Rathbone, 1616

“He answered, that the true way of Art is not by Instruments but by Demonstration: and that it is a preposterous course of vulgar Teachers, to begin with the Instruments, and not with the Sciences, and so instead of Artists to make their Schollers only doers of tricks, and as it were Jugglers: to the despite of Art, loss of precious time, and betraying of willing and industrious wits unto ignorance and idleneffe.”

W. FOSTER quoting **WILLIAM OUGHTRED.**

Oxford Science, 1630.

LIKE the venerable conundrum about the hen and the egg, it is open to doubt which of the two main operations in surveying came first, traverse or triangulation, but, judging by the first attempts of a child to walk, steering along walls or from chair to chair, it was probably the traverse. From time immemorial it has been the principal method of the navigator, and every ship's track on his chart is still made up of courses and distances run, to give a "dead reckoning", which is corrected from time to time by astronomical sights. It is essentially a method for the surveying of routes or lines.

Although geographers and geologists are usually concerned with areas, it happens often enough that they wish for an accurate survey of a natural line, such as the bed of a stream, the outcrop of a formation, the route of a path, or the line of a boundary.

For such work the method of surveying by traverse is admirably suited, and is in common use in professional surveying. The principle is the same, whether precise instruments, such as theodolite and steel tape, or rough and rapid means, such as compass and pacing, are used. Instead of a framework of triangles, or rather of points at the apexes of triangles, as in compass sketching, the control in this case is provided by a series of straight lines, known as the "legs" of the traverse, which follow closely the actual line to be mapped. These "legs" are measured both as to direction and distance, so that they can be plotted afterwards, and form a temporary framework on the plotting sheet. The details of the line itself, its curves, &c., are measured by offsets, minor measurements made at right angles to the traverse leg and at known points along it; these are plotted from the framework, which is afterwards rubbed out. The procedure is different from compass sketching, since none of the plotting is done in the field, and all measurements have to be recorded in a notebook on a definite system.

The general procedure will best be understood by taking

a simple case, the survey of a four-sided field by compass and chain, after which special cases more suited to field workers can be dealt with; for it takes at least two men to carry out a chain survey, whereas a geographer is often single-handed. The object in this case is to survey the boundaries of the field, and insert such other detail as may seem desirable.

The character of the boundaries and other detail is shown

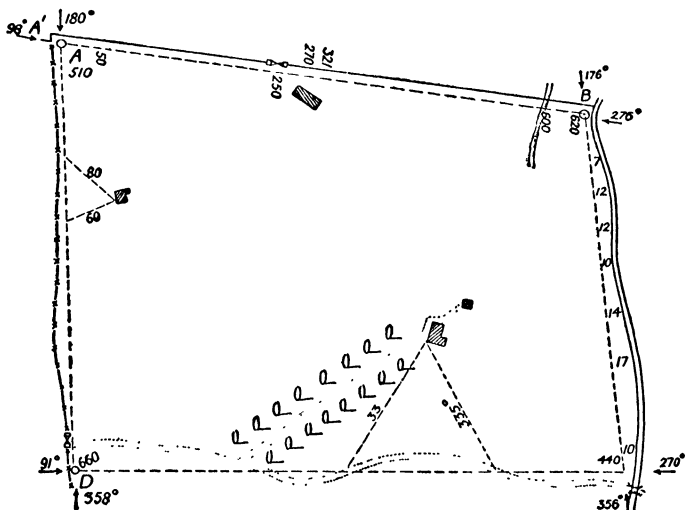

Fig. 23.—Plan of Field for Compass Traverse

on fig. 23, and the survey lines with all the measurements are also shown, the order of procedure being as follows. Starting at the north side of the field, the surveyor sets up a mark (range pole or white peg) at each end, A and B, of the first leg of his traverse. He then takes the bearing from A to B (98°), and noting that A is close to an iron fence, he takes his bearing, not from A, but well away from the fence, as at A'. The chaining of the line then begins. As the boundary is here a straight one, he needs only two offsets to it to fix it; he takes the first one at 50 along his line, an offset of 10,

judging the right angle of the offset by eye, and measuring it with a ranging rod. At 250 he finds he is opposite the middle of a gate, so he takes an offset to it (8), and measures its width (15). Immediately afterwards he takes offsets to each end of the barn, so as to get its orientation, and measures its sides. At 600 he takes his second offset to the boundary, and at 620 he reaches B. Here he takes a back bearing to A, and finds that instead of 278° (180° different from the forward bearing) it is 276° . This means that at one of those two stations there is local iron affecting the compass. If the discrepancy were 4° to 5° , he would try to get better agreement by taking the bearings at other places; with a difference of only 2° , he decides to use the mean. His further measurements for the remaining lines are shown in the figure, but one or two things call for remark. The stream boundary is irregular, so he takes an offset wherever it curves, but he saves time and labour by recognizing that the bank of the stream is an indefinite line, and therefore not worth careful measurement; he therefore estimates these offsets by eye. His third boundary is a farm road, which he can see over and chain across, so he makes his traverse line cross it, and notes the distances where he crosses its centre line. Along this line he has a good view of the house in the centre of the field, and decides to save himself the trouble of chaining to it by taking two bearings to the south-west corner of the house, as shown in the figure. The line DA runs along the iron fence, and he has to take such precautions as he can to avoid its magnetic influence. Also, he takes more care over his offsets here, as the iron fence is a definite boundary, and is also a road boundary. When passing the small cottage, he notes that it is too far off his survey line for him to trust his judgment of the right angles for an offset; so he makes two chain measurements to its corner from known points of his line, fixing it by a triangle. Finally, he visits the house, takes its dimensions and the bearing of one of its sides, and his field work is done.

So far we have said nothing about his method of booking (recording) his measurements, and it must be realized that, since all the plotting is done away from the area, it is very important that the booking should be clear, and entirely free from ambiguity. There are many different methods of booking traverses, the one recommended here having stood the test of time for the kind of traverses used by geographers, but minor variations will occur to surveyors for particular cases. The ruling considerations are as follows:

(i) The notes should be in the form of a plan of the line measured with detail in its vicinity, but without any attempt at drawing it to scale.

(ii) If possible, every line drawn in the notes should represent some feature in the field. If, for instance, an offset were entered as a little line leading off the main line, the plotter might be in doubt as to whether it were a fence or a ditch, or merely an offset direction.

(iii) The same unit of length must be used for all measurements, and bearings must be clearly distinguishable from distances. Bearings should not have the degree sign at all, since if it is carelessly written it looks like a zero, and 3° , for instance, may be read as 30, so they are put in a separate column in the system suggested.

(iv) The booking must be carefully and neatly done. There is a curious tendency for a beginner to take prodigious care over an actual measurement, but to jot it down in the notebook rapidly and carelessly. It is not till he has had bitter experience of trying to decide whether his own figure is a 3 or a 5, whether it is an offset or a main line distance, &c., that he realizes that the real test of a careful traverser is the neatness of his notebook. In general, it is a safe plan to book measurements as if they are to be plotted by someone else, who has never seen the place at all.

The booking of part of this traverse is shown in fig. 24 in facsimile slightly reduced, and the following notes explain the details. The notebook is a long one, and is used opening

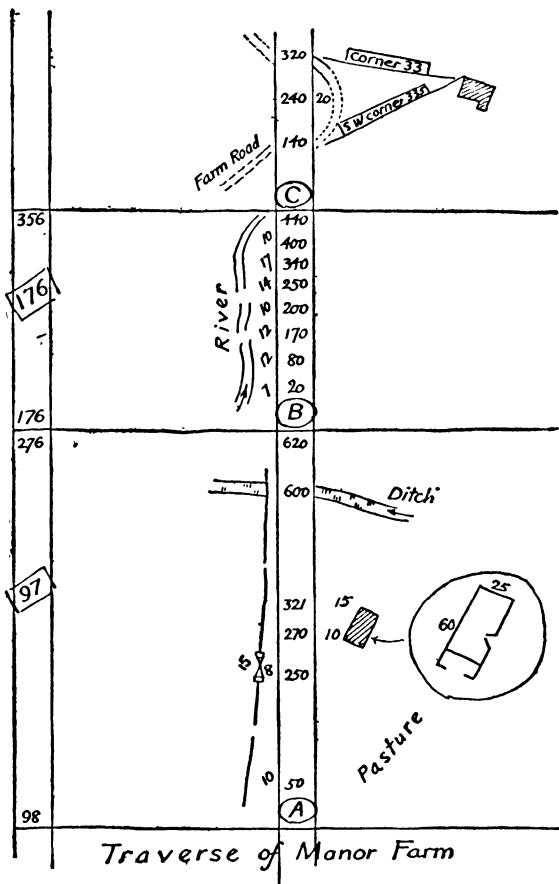

Fig. 24

it away from the body. Each page is ruled with a column up the centre, and a column at the side. The centre column represents the traverse leg, which has, of course, no width at all, but which for convenience of the figures becomes a column. Nothing but the main line distances are entered in

this column. Many surveyors book the bearings in this column also, but then the degree sign has to be used, and it is not always clear whether figures are bearings or distance. So it is recommended that a separate bearings column be used.

Starting at the back of the book and at the bottom of the page, the surveyor writes in the name and purpose of the traverse, and any other details which might be advisable. Drawing a line across he puts in the letter or number of his station, and surrounds it with a circle or oval to denote that it is a station. He enters his forward compass bearing in the bearings column, opposite the station. The other entries explain themselves, but it will be noticed that though the detail on the right and left side forms a kind of map, there is no attempt at keeping the scale correct; in fact, the only aim is clearness, and the distances are spaced widely wherever necessary to accommodate extra detail. The end of each traverse leg is marked by a line drawn right across the page, and the total distance and back bearing are entered just below this line in their respective columns. In the line CD it should be noticed how the farm road is entered as it crosses the traverse leg. On this line two bearings are taken, and it is necessary to break the rule of having no bearings written amongst distances and no lines except those representing actual detail. The bearing enclosed in a rectangle should be free from any ambiguity.

The field work of a traverse is very straightforward and, provided there are not many offsets to be taken, it is fairly rapid.

Plotting the Traverse

The result of the field work is a number of pages of notes, and the next stage in the work is just as important as the measurements in the field. It must be realized that there must be errors of various degrees in the work already, and the plotting must be arranged so that these errors will be

adjusted to a minimum, and that no serious errors due to the plotting itself shall come in.

Traverses are classified for this purpose under two headings. Closed traverses are those which, like the present example, return to or "close on" the starting-point. Open traverses are those which do not, and in exploratory work they are naturally the more usual type. The method of plotting can be precisely the same in both cases, but there are certain differences in the method of adjustment.

There are two ways of plotting a traverse:

- (i) By a protractor and scale directly from the field book
- (ii) By rectangular co-ordinates, in which the position of each station with respect to two axes is found by computation, after which the figure can be plotted with scale and compass.

For accuracy and for traverses with a large number of stations the co-ordinate method is the better, but for general work the direct plotting is adequate, and, unless traverse tables are available, quicker.

Plotting by protractor.—In this method a trial plotting has to be made which will afterwards be adjusted for errors; it is a good plan to use squared paper, ruled feint, for the first plotting, and thus save ruling for the magnetic meridian at each station.

Starting at a convenient point on the paper, the bearing of each line is set out with the protractor (a transparent one is convenient for this purpose), and the line scaled off from the measurements in the field book, working round the area. When the last line is reached it will be found that the figure fails to close. This discrepancy, which is known as the Error of Closure, requires some examination.

Every operation in surveying is subject to error in some degree which it is quite impossible to avoid, and the science of survey consists not so much in trying to eliminate errors, but in finding what errors have been made, and applying corrections. In the case of a traverse the errors are due to

both the operations, the compass errors in direction, and the chaining errors of distance, and these two are combined in some unknown proportion in the error of closure. To some extent these errors are compensating, since the measurement of length is sometimes too long and sometimes too short, the bearings sometimes too great and sometimes too small but it should also be clear that the greater the length of the traverse the greater the error is likely to become. Consequently we can with some justice say that the longer the traverse the greater the error; in other words, that the error is proportional to the distance gone.

Strictly speaking, this assumption can never be quite correct, except in a traverse with an infinite number of stations. Putting it in the opposite way, the fewer the stations in a traverse the more likely is it that the bulk of the error of closure is due to one bearing or one line. When this is suspected by the surveyor whilst doing his field-work, such as when one of his lines is over more difficult ground than the rest, or one of his stations is badly influenced by "local iron", he can make an allowance by estimation as will be shown later.

Returning to the error of closure of a traverse, it is obvious that this error must be distributed amongst the stations, and it should be done in accordance with the above assumption; the second station from the beginning of the plot is corrected least, and the rest in increasing proportion up to the last, which has to be moved the whole of the error in order to close the figure. This can be done quite easily by a graphic method, and indeed it is not worth using a more exact way of proportioning the error, since the assumption on which we base our procedure is itself but a broad and general one.

The error of closure is represented by a gap which has to be closed up; therefore all the stations must be moved, in due proportion, in the direction of that gap. The first thing to do is to rule lines through each station parallel to the error of closure. Next, the total distance of the whole traverse is

set out on a piece of paper in a straight line, or, since that might demand a large sheet, half the perimeter, or any other fraction of it. The legs of the traverse are marked off along this line as shown in fig. 25, and a perpendicular equal to the *actual* error of closure is erected at the end; the triangle is completed by ruling the hypotenuse, and small perpendiculars are erected at each station along this reduced peri-

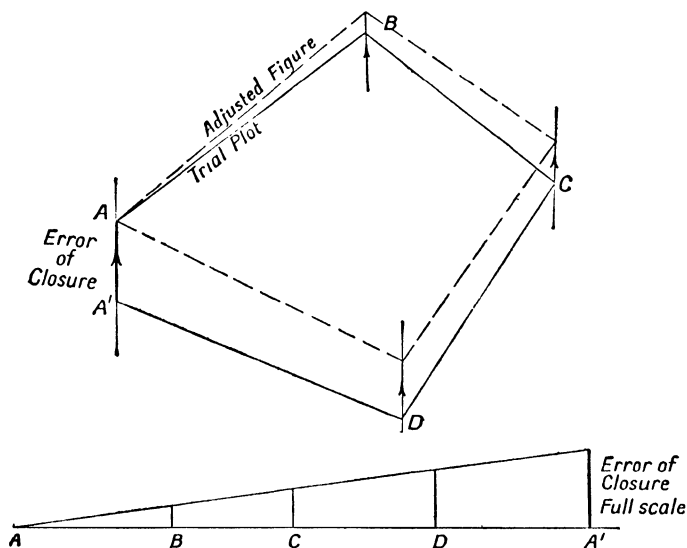

Fig. 25.—Adjustment of Plotting

meter. We have thus apportioned the error of closure graphically between each line; with a pair of dividers or a scale we now set off these small perpendiculars on the parallels drawn through the stations, in regular order, rule a new perimeter through these points, and the figure is closed. The adjustment has therefore achieved its purpose in closing the figure on the most reasonable assumption as to how the error has accumulated.

It will be noticed in the figure that all the original figures

have been altered to effect the closure, both the bearings and the distances.

It often happens that in doing the field-work, we realize that one or more legs of the traverse has been more difficult than the others, and likely to contain more of the total error than is proportionate to their length: one leg, for instance,

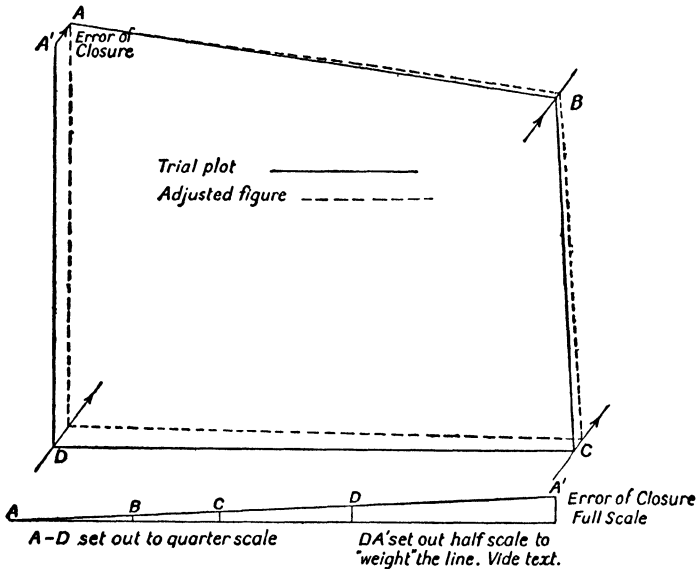

Fig. 26

may be through heavy undergrowth, making it difficult to measure the distance. If the surveyor is quite sure of such a fact, he may give extra weight to those "suspect" legs in making his adjustment. If, for example, in this present survey the line along the iron fence were complicated by difficulties in chaining and taking bearings, we might decide to give it a double proportion of the error; this is done by doubling its length in the construction figure, as shown in fig. 26, which is the plotting of the Manor Farm traverse.

The figure being now adjusted on the squared paper, it can be transferred to a piece of drawing paper, preferably by laying the trial plot on the drawing paper, and pricking through the station points with a fine needle. The stations are then joined by straight lines in pencil, and we are ready to plot the detail. This can be done with any ruler and scale, but for regular work, and a long traverse, it is worth while to make two scales on strips of card or drawing paper, a long one to lay along the traverse leg, or parallel to it, and a short

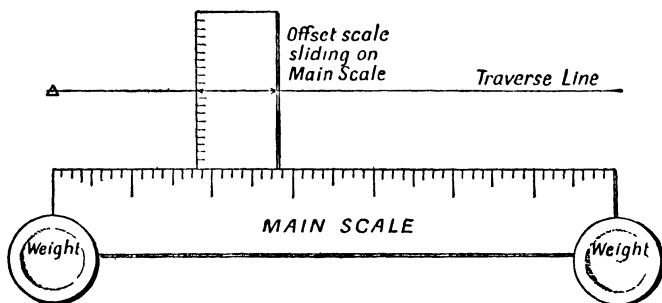

Fig. 27.—Cardboard Scales for plotting offsets

offset strip to slide along the first one, as in fig. 27. The long strip is then fastened by weights along the line to be plotted, and the offset scale slid along it to plot the offsets without having to move the main-scale. This plotting, though only in pencil, is the final one, and should be done carefully, for when inking in at the end every pencil line is followed by the pen. When thus inked in, the traverse legs are erased, and the map is finished.

Plotting by Co-ordinates.—The co-ordinate method is worth knowing, although it may appear to be complicated, since, for regular work and with the assistance of traverse tables, it is very much quicker than the protractor method, and no trial plot has to be made. Briefly, it consists of using the magnetic meridian as one axis of rectangular co-ordinates,

and calculating the position of each station by trigonometry, from the bearing and distance of the traverse legs. Fig. 28 illustrates the method, and the terms used.

ABCD represents the traverse to be plotted, and A, its most western station, is taken as origin. The first line, AB, has a bearing θ and a length D . From these we can calculate AX and BX, the rectangular co-ordinates of B from A. AX

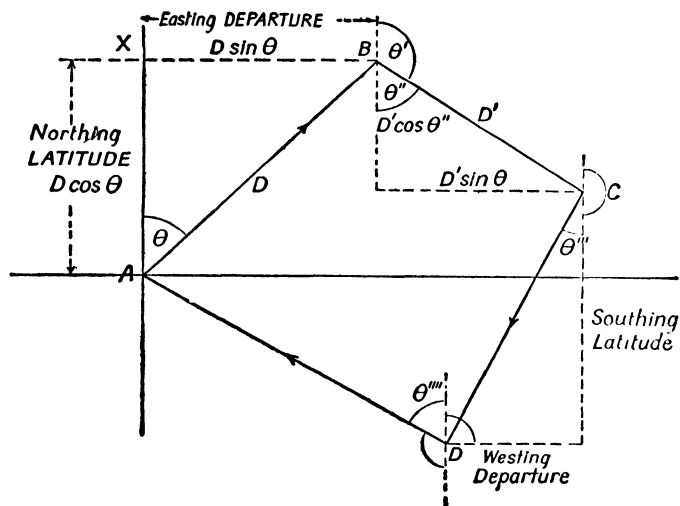

Fig. 28.—Plotting by Co-ordinates

is $D \cos \theta$, and BX is $D \sin \theta$. These co-ordinates are known respectively as the latitude and departure of B. The bearing of BC is θ' and its distance is D' , and we can get the co-ordinates of C from B in the same way. In order to keep the sine always for the departure, and the cosine for the latitude, for the purpose of traverse tables we use, not θ' , the actual bearing in this case, but θ'' , the supplement of the bearing, or, as one pupil expressively put it, "the nearest way to the meridian". This gives us the latitude and departure of C from B; but we can get the co-ordinates of C from A, the

origin, in this case, by adding the two departures together, and subtracting the latitude of C from that of B. Continuing, we use θ''' for the co-ordinates of D from C (and θ'''' for the co-ordinates of A from D), and by adding or subtracting latitudes and departures as necessary, we can get the co-ordinates of D from A.

For purposes of adjustment (and for taking out areas from the figures if required), the co-ordinates of each point are given a direction, according to the order in which they are calculated. In going from A to B, for instance, we went north and east, so the latitude is called a "northing", and the departure an "casting"; from B to C we go south-east, and the latitude is a "southing", the departure an "easting"; for D from C we have a "southing" and a "westing", and from D to A a "northing" and a "westing".

If we label our co-ordinates in this way, and put them in separate columns in a table, we can find our error of closure very simply, for, since the traverse returns to its starting-point, the northings and southings should be equal, and similarly for eastings and westings. The error of closure therefore shows up as two figures, the co-ordinates, in fact, of the total gap left if the figure had been plotted. But in this case we can distribute the error in proportion to the length of *each* line, and not increasingly from the first station. The reason for this is that, in plotting by protractor, each error, as plotted, affected all the stations to come afterwards, while in this case the station positions are calculated independently. The method of adjustment is shown in the sheet of co-ordinates (fig. 29), as worked out for the same traverse as was plotted by protractor. The multiplication of the distances by the sines and cosines of the angles would be a laborious task, but traverse tables are available, either published separately, or in mathematical tables such as Chambers', which make the work simple and quick. A short form of traverse tables will be found at the end of the book.

When the co-ordinates have been corrected, they are added

Line	Bearing	Reduced Bearing	Distance	LATITUDES		DEPARTURES		Total Co-ordinates Station	
				Northings	Southings	Eastings	Westings	N + S	E + W
AB	97	S 83 E	620		75.5	615.3		-75.5	+626.3
BC	176	S 4 E	440		438.9	30.7		-439.4	+30.7
CD	270½	N 89½ W	660	5.6	439.4		659.8	+5.6	-648.1
DA	359	N 1 W	510	509.8		8.9		-509.3	+8.9
				515.4	514.4	645.0	668.7	+509.3	- 0.0
				515.4	514.4	645.0	668.7	0.0	0.0

Diff 1.0

-22.7

N.B. Corrections in Heavy Type Final figures in heavy type

Working in Full	LAT.	DER
S 83 E	600	595.5
	20	19.8
	620	615.3
S 4 E	400	27.9
	40	2.8
	440	30.7
N 89½ W	600	599.9
	60	59.9
	660	659.8
N 1 W	500	499.9
	10	9.9
	510	509.8

The discrepancies of 1.0 and 22.7 in Latitudes and Departures are distributed by adding half to the lesser column and subtracting half from the greater. The apportioning of the amount to the different co-ordinates is done approximately in proportion to their size. Thus in the Departures the difference of 22.7 is split up into 11.0 to be added to Eastings and 11.7 to be subtracted from Westings. The whole of the 11.0 is added on to the longest co-ordinate, 615.3, but 10.0 might have been added there and 1.0 to the co-ordinate 30.7. It must be realised that more accurate apportioning than this is useless since the assumption itself is only an approximation. The latitudes and departures are taken from the tables at the end of the book.

Fig. 29

or subtracted to give the total co-ordinates from the origin, and the arithmetic is then finished. The plotting is done by drawing two axes in a suitable position on the drawing paper. The measuring off is made easier if a beam compass, or "trammels", is used to take the distances off the scale, and to strike arcs from the respective points along the axes.

Open Traverse Adjustment

So far we have dealt with the adjustment of error in a closed traverse only, that is to say, in a survey which returns to its starting-point. In an open traverse the adjustment is made on similar principles, but it can only be done if the true position of the two ends is known from other evidence, such as from a map or a triangulation survey, or, if the traverse be a very long one, from the latitude and longitude of the end stations.

We will take the case of a traverse some ten miles in length, in England, starting and ending at points known to be on the 1-in. Ordnance Survey maps, such as a traverse across

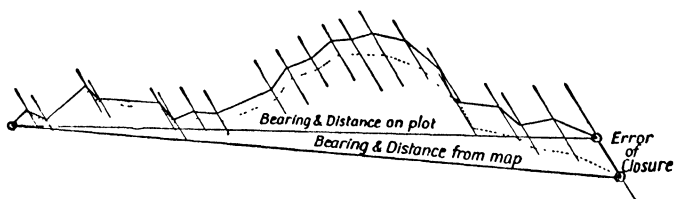

Fig. 30.—Adjustment of an *Open Traverse*

the Yorkshire moors by compass and pacing. The trial plot is made as before to the scale required, say 1 : 30,000. The bearing and distance of end point from starting-point is then taken off the 1-in. map, and, altered in scale to 1 : 30,000, is plotted on the trial sheet from the starting-point, the result being as in fig. 30. The gap between the traverse end point and that taken from the Ordnance map is the error of closure, and it is adjusted in the same way as if it were a closed traverse. More probably such a traverse would pass through several known points, and in such a case greater accuracy

would be gained by adjusting from the map for each section of the traverse separately. Indeed, a little experience will prove that, provided a traverse passes through known points occasionally, rough work with compass and pacing will give excellent results after adjustment, and it is usually worth while going off the line of a traverse occasionally to "tie on" to some such known point.

Types of Traverse

Having described the practice of surveying by traverse for ordinary conditions, we will now give some consideration to other methods of getting bearings and distances for traverses of special character. As far as alternative methods of finding the direction of traverse legs is concerned, the choice is very limited, since we are not here concerned with theodolites, or other precise angle-measuring instruments.

Lest it should be presumed that for lack of a prismatic compass no attempt can be made at a traverse, it may be mentioned that quite a useful survey can be made by graphic angles made at each station; the beginner without a compass might well practise traversing in this way. In the survey described above, he would lay his notebook on the ground at each station, and with a ruler laid on it he would sight back on the line just paced, draw a ray, and, sighting forward on the next leg, rule another ray, and then label the angle so obtained with the name of the station, noting which station the ray points towards, as in fig. 31. Such angles should never be more than two or three degrees in error, if care is taken, and the errors will be compensating to some extent.

The application of the traverse to making maps is almost unlimited in its variety, and no attempt can be made to cover more than a few cases. Nevertheless, so much of the work of a scientist in the field is concerned with tracing and mapping lines of one kind or another and under different circumstances, that it may be useful to suggest modifications of the normal method suitable to some special cases.

There is an excellent detective story in which the hero is captured and driven away in a closed carriage. Being a man of resource, he at once begins noting the time between each corner turned and estimating the nature of the turn, whether a full right angle or less or more. When he is left to himself in his new prison, he plots these figures and finds that all the twists and turns of an hour's drive were to delude him into thinking he was far away from the point of his departure, the

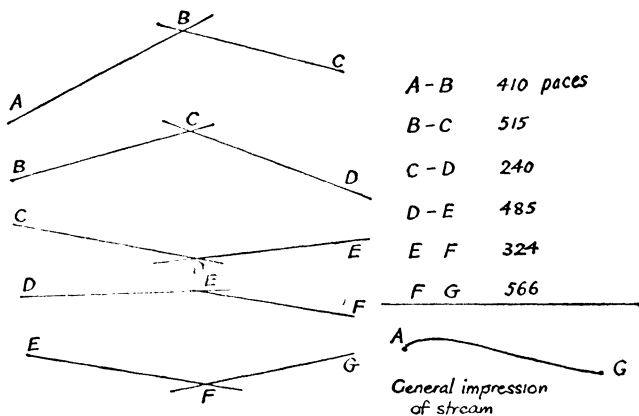

Fig. 31.—Page from Notebook of a Traverse without a Compass

plotting showing that he had been brought back to the same place.

It is left to some ingenious reader to prove whether this is possible or not, but it will serve as one extreme in the list of traverse methods.

The following account of an official method of traverse in regular use will show the extent to which compensation and adjustment can be used.

In parts of West Africa where the jungle is so dense that visibility is reduced to a few yards at a time, and winding native paths are the only means of progress through the

forest, the "rope and sound" method is practised. A rope, two or three hundred feet in length, is dragged along ahead by an assistant until it is taut. By this time he is completely invisible, and the rope is a series of short straight lines from one tree trunk to the next. The forward man then halloos a few times and the rear man takes a bearing to the sound. This is repeated for each length of the rope. The plotting is done just as for a normal traverse except that a deduction for the curvature of the path is made for the distance between each station. Experience has shown that a very reasonable accuracy can be attained, and that the errors compensate each other to a large degree. Such traverses are, of course, adjusted by beginning and ending them at known points on much more rigorous traverse lines set out with a theodolite along roads or special lines cut through the jungle.

Such extreme methods are, however, unlikely to come the way of the reader, and it will be as well to consider some of those that may occur, first in this country and then farther afield, and especially those which could be attempted single-handed.

One of the most difficult of surveys to make is that of an outline which cannot be seen at a distance and which has little associated detail to define it. Examples are a stream bed flowing through a marsh or mud flat, the outline of a lagoon in flat or reedy ground, or a line of drainage on a highland moor. In all these cases it is the next station which causes the trouble, for it is tedious to have to walk forward constantly to see where the line is and place a mark.

A method which would suit many such cases is to have a major traverse of longer legs as a framework to the minor traverse of many short ones, and this is particularly useful for a meandering line which often bends back upon itself. On the way out the traverse is made with short legs following the curves as closely as may be desired, but every now and then a visible mark is left at a station. On the way back, a traverse is made from each of these stations to the next on

a very much shorter course than on the way out, as shown by the figure.

The traverse may then be treated either as a closed traverse, the whole being adjusted for error of closure, or, preferably, the major traverse could be plotted as control and the minor be adjusted to it loop by loop.

There is another method of checking by cross bearings which might also be used, but it is more suitable for traverses over long distances, of the exploratory type in fact, when the surveyor may have little idea where his route is going to take him. Where there is a map to be had covering the area, the procedure is simple enough. We will suppose that the mud flat in the above example was all the time within view of a church or windmill or other prominent mark from which the starting-point of the traverse can also be located. The surveyor would then take a bearing to the mark every now and then, choosing one whose direction is more or less at right angles to his route.

These bearings will be turned into back bearings, that is, bearings from the church, when plotting, and each will give a rough check. If bearings to two marks can be taken each time, their intersection may give a very much better check.

In an exploratory traverse, where there is no map, the

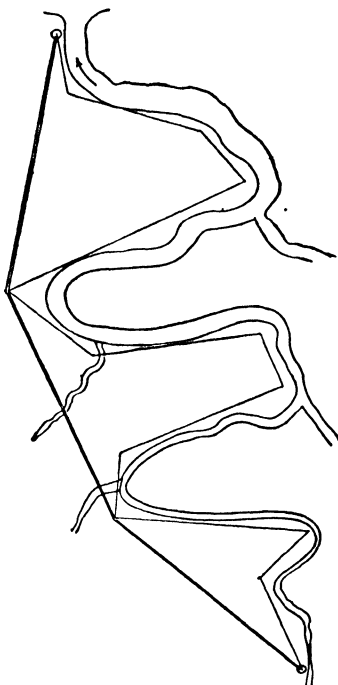

Fig. 32.—Plan of traverse lines on a salt marsh. Double lines mark return measurements

surveyor will have to fix distant marks such as mountains, approximately, from the first few legs of his traverse. When he has got enough bearings to give them a satisfactory "fix", the same marks may be used as checks for the rest of the traverse. The same is true of prominent marks which are close to the line. These will be fixed as they are passed, and will serve as a check later on when sighted to from future stations.

The type of boundary usually required by the geologist and botanist is still less definite than the geographer's muddy creek, for most rock outcrops are obscured to some extent by soil cover, and boundary lines between different kinds of vegetation are almost always ill-defined. Such work cannot aim at great accuracy, so the mapping will usually be quick and easy, except where the lines pass through woods or scrubby lands which prevent long sights to the next station.

Considering different types of traverse in another way, we find that they tend to sort themselves according to the kind of transport or method of travelling.

To the schoolboy the traverse by bicycle will naturally appeal since he can cover a large extent of country thereby, even if he has to keep to lanes or paths. With a counting mechanism on his wheel and taking care that he is more than 10 ft. away from his bicycle when he takes a bearing, there are no difficulties in this kind of work beyond those incidental to the route itself. A traverse by car is in the same category, except that the route is usually even more limited.

In both these cases a recording mechanism can be used to relieve the tedium of counting, but in other cases, such as long walking tours, it can be avoided by using the time and rate method. Each station for a new bearing then has a time of stopping and starting against it, preferably in a separate column, and the estimated rate of travel is put in occasionally opposite the legs of the traverse.

A large part of the world is still mapped by the time and rate method of travel, either from horseback, or with a caravan

of camels or carriers. It is particularly suitable for steppe or desert travel, where the rate is likely to be uniform for long periods, and the courses steered are usually fairly steady. The larger the body of men or animals in the caravan the more uniform will be the rate.

Traversing in polar regions gives the same kind of problems, but in that case it is usual to drag a cyclometer wheel (or sledgometer) behind the sledge to record the distance.

This note on different kinds of traverse would be incomplete without mention of work done from boats. The chief difficulty is to find the rate at which the boat is travelling, but there are usually ways and means of doing this even with dug-out canoes manned by native paddlers. I happen to have done some hundreds of miles of traversing streams in this way, and some remarks on the methods I gradually learned may be useful as they can be adapted to similar work in other craft.

The mapper must be comfortable, as he will be working without a stop for hours on end, and he must also be able to see over the paddlers' heads. Therefore he wedges a camp table between the thwarts of the canoe and he sits on a box or stool. At the front of the table he places his compass, opened out so that its sight-line is pointing to the bow, and it should be fastened down in some way. Having previously timed the normal rate of paddling over a measured distance, the mapper prepares a time scale of minutes on a piece of card or paper. Usually he will want to put in the width of the stream to scale so it is liable to be a large scale. He needs a small protractor and his watch both handy in front of him. His plotting is done on lined foolscap paper turned sideways, the lines acting as magnetic meridians all over the paper.

Starting off, he takes the bearing of the course of the canoe along the first reach. He sets it off from the nearest meridian line to the point he has chosen for the plotting. He rules that line for a short distance and ticks off spaces for the minutes along it from his time scale. As the canoe goes along he sketches

in the river banks by eye, estimating its width and noting down on his map whatever other detail he wants, the bearing with minutes marked on it being his guide.

When he becomes expert—which will happen after a few hours—the mapper will find that he can include on his map such a wide variety of things as villages, cultivation, natural vegetation, landing-places, sand-banks, strength of current (estimated), depth (by getting a paddler to sound with his paddle), and so on, even to putting in a conventional sign for each crocodile or hippo seen. At the first bend or change of course, the drawing ceases for a moment until the canoe has settled on its new course, when a new bearing and new scale of minutes is drawn. The bend is then sketched in and the detail resumed as before.

The mapper is continuously using his judgment, of course, noting such things as a decreased rate of paddling, to counteract which, with the men I had, the best thing is to get them to sing or to crack a joke at someone's expense, which sets them laughing and wise-cracking for half an hour as they paddle. Sheet after sheet is filled as the scale is so large, but the change-over from one to another is simple enough.

This example has been taken from the channels in the Bangweulu Swamps of Northern Rhodesia, but exactly the same procedure can be used from a punt or a rowing-boat or a motor-boat anywhere in the world, the method being suited to the craft. Thus, on another occasion, a traverse about 100 miles long was made from the upper deck of a stern-wheel paddle-steamer on the Shire River of Nyasaland. This was the most luxurious and comfortable surveying that has ever fallen to my lot, seated at a firm table some 20 feet above water-level, whence one could see over the reeds and far beyond so that a wide expanse of land could be mapped. I could check the speed from the number of revolutions of the paddles, there was shade from an awning, and even a cookboy to bring cups of tea. The course was up-river and took four days against a strong current so there was ample time to note down detail,

especially when we had run foul of a sandbank or had some other minor accident.

In both these examples the great advantage was that the map was practically completed as we went along, the only work for the camp at night being inking in and rubbing out lines of bearings. The starting-point and end of the traverse are almost certain to be places on the map, so the usual adjustment can be done for error of closure.

The method thus outlined is so much less precise than ordinary land mapping that we must assess its value. It must be remembered of course that in these two cases the area was more or less unmapped and the main object was to get in the bends of the river with reasonable accuracy. It so happens that in the case of the canoe traverse there was a severe test some years later, when we visited the same swamp armed with aerial photographs. The initial traverse not only compared well with the photographs but every now and then gave us a guide, by some such sign as "Single palm" or "Patch of tall reed", to where we were on the air photograph. Nevertheless, one could not describe such mapping as anything more than a "reconnaissance survey", to be replaced in time to come by more professional work.

The same thing applies to traversing by car or lorry. As in the case of the iron stern-wheeler, there will be interference by the steel-work and therefore a "deviation error". It is possible by trial and error to find a place in a car where this deviation is at least not excessive. Again, it is the general course followed, and detail along the route which is required in the reconnaissance and the map can be adjusted by the end-points as before.

Drawing the map as one goes along is impossible in a lorry owing to the vibration and one's traverse notes are liable to be illegible. The illustration (p. 96) is a facsimile of a page from a survey from a lorry in the Kalahari, which in the end was nearly 2000 miles in length, with at least 8 adjustment sections, yet it is, to date, the most accurate map of those parts. The

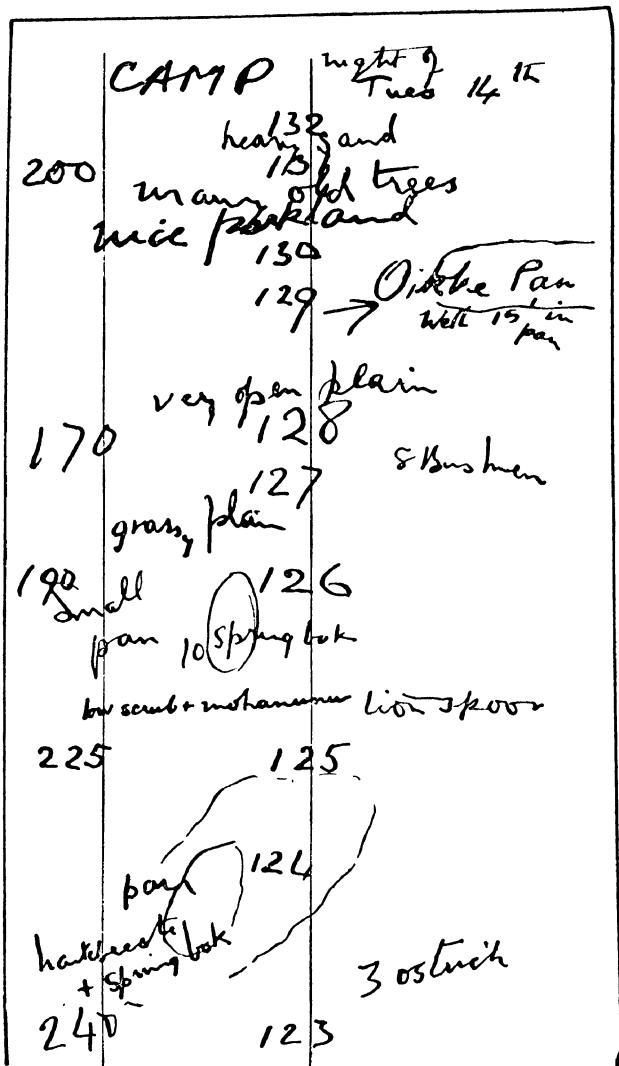

A page from a lorry traverse

hazards in that traverse may just be mentioned. The worst were the bumps, but sudden turns to avoid obstacles, the swarms of insects coming in as we brushed against a bush, and the sticking of my wrists to the paper may be added. On the other hand, the speedometer in front did all the distance measuring and I only had to note down changes of direction at a given mileage, together with objects of interest—in that case it was mostly changes in the vegetation.

For more exact work it will be found a great advantage to put the compass on a light tripod, and use one of as large diameter as possible for more accurate readings. It will be noticed that nothing has been said of using steel bands or anything more accurate than a linked chain, and a little reflection will explain the omission. The traverse depends on both the distance and the direction measurements, and to increase the accuracy of the one without the other would be practically useless. The small prismatic sighted in the hand fits in with pacing, wheel measurement and time and rate, the tripod compass with chaining, and it is not until the theodolite is called in for the angular measurement that the accuracy of the steel tape is of any real value.

Enough has been said to show the universal application of the compass traverse to the mapping of routes or boundaries, and in spite of its inaccuracies and the fact that it is plotted afterwards and not in the field, the method still stands as the one most frequently used in the less fully surveyed parts of the world.

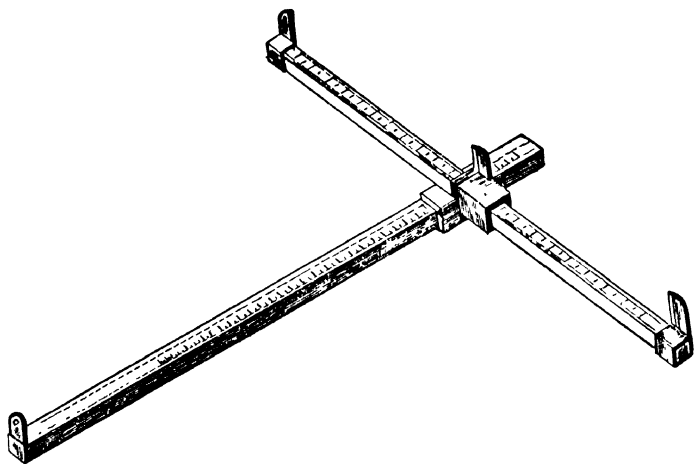

Gunter's Cross Staff, 1624

Chapter VII

DETERMINATION OF HEIGHT

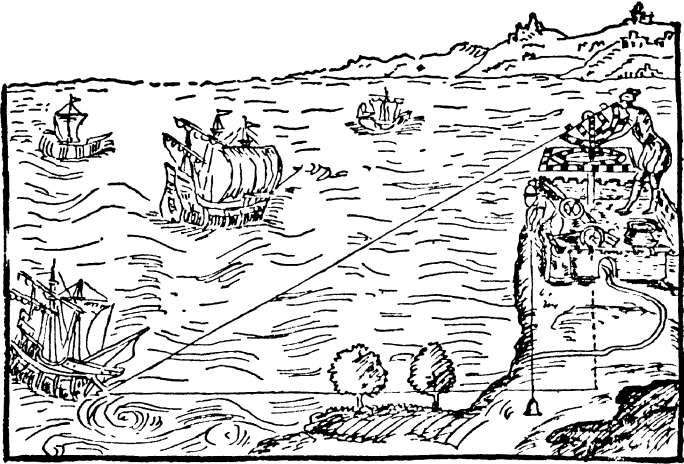

After Digges, 1571

*“If you adde the Square of the partes cutte in your Scale, to 14400 reseruing the product for a Diuisor, and multiplie the Square of the distance Hypothenusall in the Square of the partes cutte in the Scale, diuiding the offcome by the reserved Diuisor, the roote quadrates of the Quotient is the foresaid difference or vnequalities of leuelles.”**

DIGGES' "Pantometria", 1571.

NEITHER the geographer nor the geologist can be satisfied with maps which give no indication of the relief of the country, and often enough their own surveying consists entirely in adding heights to an existing map, in order to make it of use to them. A thorough treatment of the subject is therefore indicated for a book intended for the field scientist.

The various ways of showing relief on maps must be referred to briefly. The method of "spot heights", which are heights above datum level printed close to a dot on the map, is not by itself a very useful one, since they give no real picture of the relief. When sufficiently close together, however, they permit the interpolation of some other method, and may therefore be regarded as a stage which is usually gone through in the preparation of a map.

The old fashioned hachure or shading for slopes can be

* Since Mr. Digges is not so explicit in the quotation opposite as we could wish, a note of explanation follows. The "Scale of the shadows" seen on several of the old instruments illustrated was graduated to 12 or 120, and the diagram shows his somewhat involved method of geometry.

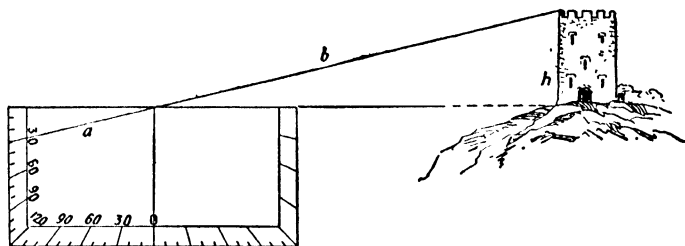

Let h be the "unequalitie of levelle" and b the "distance Hypothenusall". The sight line is on 30 "partes cutte in the Scale" and a is the hypotenuse of the scale triangle. Then

$$\frac{h}{b} = \frac{30}{a} \quad \text{or} \quad \frac{h^2}{b^2} = \frac{30^2}{a^2}$$

whence

$$h^2 = \frac{30^2 b^2}{a^2} = \frac{30^2 b^2}{120^2 + 30^2}$$

$$= \frac{\text{"square of partes cutte in Scale"} \times \text{"square of the distance Hypothenusall"}}{1440^2 + \text{"square of partes cutte in Scale"}}$$

So the root quadrate, $\sqrt{h^2}$, is the difference of levelle.

very effective indeed, provided it does not degrade to a mere hairy caterpillar, and for some purposes gives a better picture than any other method, but it will be disregarded here for the double reason that it needs very careful drawing, and does not permit actual measurement of a height from the map.

There remains the method of contours, lines of equal height marking out where successive rises of sea-level would trace a shore line. The system has now been so long in use that nearly everyone understands and can read contours, but they do not give a ready picture of relief. A useful modification is given by layer colouring, the areas between contours being shown by a tint of colour. Provided there are not too many contours this is very effective and not difficult for an amateur to do. The stepped effect is a trifle unnatural in gently rolling country, but is not annoying when the slopes are steep.

Strictly speaking, a contour should be a line surveyed with almost as much care as a boundary. The original method used by the Ordnance Survey was to send a levelling party to fix each of the contours on the ground, and put in lines of pegs as they levelled round each slope. The pegs were afterwards surveyed by traverse by another party.

This excellent but very expensive way is now rarely followed, and the rigorous use of the word "contour-line" has largely disappeared, for the majority of maps showing contours depend on nothing more accurate than interpolation between spot heights or some such method. Therefore the great gulf that should properly be fixed between the terms "contour" and "form-line" has tended to disappear. It is highly desirable that maps with contours should have some statement as to their relative accuracy or method of survey: even the Ordnance Survey is an offender in this respect since it prints in an equally firm line those contours which have been interpolated by office draughtsmen and those which have been fully surveyed. Properly speaking, the "form-line" is a level line intended only to show the

shape of the land forms and has no definite height assigned to it, being usually drawn in by eye in the field. Actually there can be all degrees of accuracy between such a form-line and a fully surveyed contour.

For the geographer and other field scientists the problem is first to illustrate the land form and then make that illustration as exact as time permits. Generally speaking, the maps considered in this book will have form-lines of moderate accuracy, a safer and more satisfying description than if they were to be called contours of minor precision or any such misleading term.

The final aim in all maps showing relief (topographical maps is the correct name) is to have lines of similar level forming closed curves, from which a picture of the country can be had, and which will permit measurement of individual heights with some assurance.

The contours or form-lines, however, are but the last stage in a series of determinations of height of stations, and the preliminaries to drawing contours are always rather long.

There are three approved ways of finding differences of height between points, each with its own merits and demerits; and these may be classified as follows:

(i) By aneroid barometer; rapid, but not very accurate.

(ii) By clinometer; the commonest and most useful from the point of view of the amateur surveyor.

(iii) By levelling; the most precise, and the most tedious.

There are other and more exact methods which are outside the scope of this book and of the amateur surveyor.

Heights by Aneroid

The indirect method of finding height above sea-level by the pressure of the air is well suited for rapid travel, and for moderate ranges in height, since the only instruments required are a pocket aneroid and a thermometer. We are not concerned here with its use for mountain climbers, but rather

as to its application to survey work, without going into extraordinary refinements.

The instrument is really a spring balance, weighing the air above it, but giving the result in inches, derived from the mercury barometer unit. These weights of air at different heights above sea-level are remarkably constant for steady conditions of the atmosphere, and have been turned into measures of height, by computation and experiment. They are to be found in physical tables such as those published in

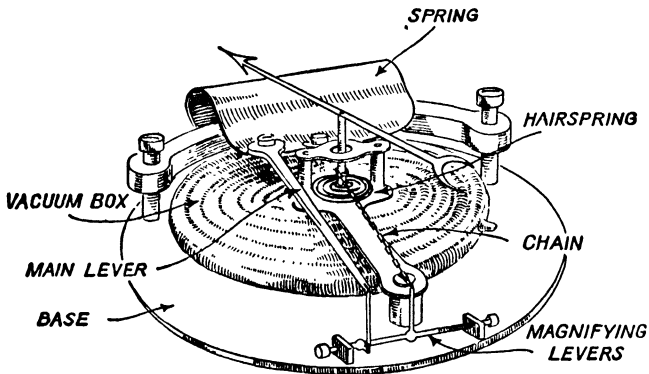

Fig. 33.—Aneroid Barometer

Hints to Travellers, the survey manual of the Royal Geographical Society, but in a surveying aneroid the maker engraves them as feet outside his inches scale.

The result is affected by a number of variable conditions, most of which we can afford to neglect, but which must be mentioned, lest the beginner consider he has discovered the perfect method of measuring heights. For example, since gravity alters with latitude, being greatest at the poles, the weight of the air, and thence our height scale, varies also with latitude. Again, the weight of the air varies with its density, and that depends on the temperature of the air, so there must be a temperature correction to the height scale. Fortu-

nately these two corrections can be ignored for ordinary survey work, but a third variation is so important that in certain states of weather the aneroid becomes almost useless for our purpose: the pressure of the atmosphere has a daily variation, and is also subject to the passage of belts of high and low pressure, which are so familiar a feature of the weather in these latitudes. In the tropics the diurnal variation is often so constant that tables of correction for the variation may be constructed, the amount of correction depending on the time of day. But in the temperate zone, the variations of pressure are irregular, and corrections can only be applied if these variations have been carefully recorded. Thus in stormy weather it is not unusual for the barometer to change $\frac{1}{2}$ in. in a few hours, which is equivalent to about 400 ft. in height.

Because of these and other factors, one cannot depend on an accuracy of more than 20 to 50 ft. in the readings of an aneroid over a moderate range. On the other hand, if we are concerned with differences of height along a route, rather than absolute height above sea-level, we may trust the aneroid to as near as we can read it, probably not less than 10 ft., provided we apply the corrections for the variations of pressure during the period of the journey. There are conditions under which this, or even a less accuracy, is sufficient for the purpose, and the observations are quicker than by any other method.

Let us imagine that the heights are required on a walk in the Highlands of Scotland, at a general height above sea-level of 1000 ft. or so, where the surveyed contours on the Ordnance map are at an interval of 250 ft., or even more. The general procedure would be as follows. Starting from a point whose height is known, the outer ring of the instrument, marked in feet, is set at that height so that the index pointer of the dial points to the actual height above sea-level, and the time is noted. Whenever a point is reached whose height is required and which can be identified on the map, the aneroid is tapped

gently with the finger, and the reading noted, together with the time. (It should be remembered that the instrument should always be read in the same position, preferably horizontally in the hand.) If a point is reached whose height is already on the map, the reading of the aneroid is noted, and we then have a measure of the error, up to that point; the instrument could then be reset to read correctly, and the walk continued.

No regular method of booking the readings is in use, but something like that used in fig. 34 would serve.

If the walk is ended at another point whose height is known, we have a final check on the error of the readings, which is almost entirely due to the changes of pressure during the day. For greater accuracy it will be necessary to correct the readings for these changes, and it can only be done by obtaining the readings of some barometer in the district, the readings of which have been noted from time to time during the day, or have been recorded by a barograph. In the example in fig. 34 a barograph curve has been obtained, and the procedure is then simple enough. The times at which the various heights were read are marked on the chart, and the variations from the initial reading are measured off in decimals of an inch, and put in the appropriate column, with its sign, positive for higher pressure, negative for lower. These are then turned into feet in the next column, allowing 900 ft. to 1 in., and the addition or subtraction made, giving the adjusted heights of each station in the last column.

It will be noticed that no other correction than for the variation of pressure is applied in the above case, but under certain circumstances, particularly when the range of height is of the order of 1000 ft., the temperature correction may become important. This does not refer to the temperature of the aneroid itself, for that is usually constructed so as to be self-compensating for ordinary variations of temperature. But the tables and the graduations on an instrument are generally calculated for a definite mean temperature of the

Time	Station	Aneroid Reading	Barograph change in inches	Correction Feet	Adjusted Height
<i>a.m.</i>					
10·00	Leargan	800			800
		Aneroid set to 800			
10·15	Carie mouth	700	-.04	-35	665
11·00	Fork in burn	800	-.05	-45	755
11·40	Gate and bridge	1160	-.07	-60	1100
<i>p.m.</i>					
12·20	Butts	1660	-.10	-90	1570
12·50	Watershed	1810	-.12	-110	1700
1·30	Bridge	1665	-.14	-125	1540
2·00	Junction of Burns	1060	-.17	-155	905
2·30	Church	840	-.2	-180	660

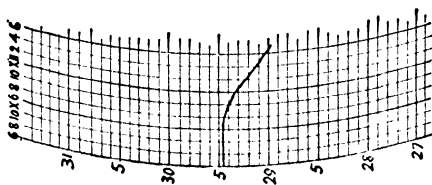

Fig. 34.—Example of Booking of an Aneroid Traverse

column of air between the upper and lower stations, usually for 32° F. For any other mean temperature a factor must be used to correct for the difference. These may be found in the Royal Geographical Society's *Hints to Travellers*, but for ordinary work the following table will suffice.

Mean Air Temperature of Upper and Lower Stations	Percentage to be added to Height
40° F.	2
50°	4
60°	6
70°	8

It will be seen that although on a summer's day the computed height above sea-level of the individual stations will be considerably modified by the temperature correction, it will not affect the differences of height between stations very much. The air temperature, therefore, can be neglected unless the range of height and temperature is considerable.

Heights by Clinometer

This heading refers to the determination of difference of height by trigonometrical calculation, the two requirements

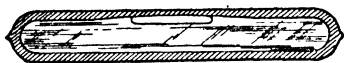

Fig. 35.—Bubble tube

being the length of the base of the triangle (or the slope distance) and the vertical angle subtended at the

observer by the difference of height.

The name clinometer is intended to include any instrument which will give vertical angles; there are several types to be had, some using a small pendulum to give the vertical line, and others using a small spirit bubble. The longer the pendulum used, the more sensitive will be the instrument; yet a hand instrument cannot have a long pendulum. A spirit bubble, on the other hand, is nothing more nor less than a closed tube, with its inner surface ground to the arc of a circle, and its degree of sensitiveness depends in large measure on the radius of this arc. Even in a small spirit level this radius

is seldom less than 10 ft. or so, and it is therefore roughly equivalent in sensitiveness to a pendulum 10 ft. long: not exactly equivalent, for the bubble by which the level is read is of a definite size, and not to be compared with a fine line on a graduated arc, by which a pendulum might be read. In general, however, a bubble instrument is capable of far greater accuracy than any pendulum instrument.

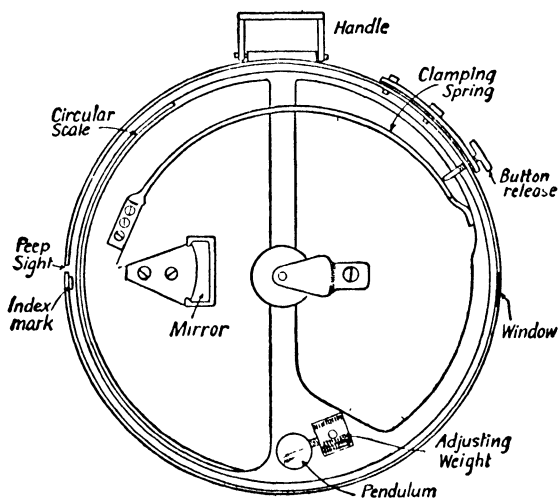

Fig. 36.—Diagram of Watkin Clinometer

For practical purposes, only two instruments are applicable to the type of surveying dealt with in this book, the Watkin clinometer, using a pendulum, and the Abney clinometer, using a spirit bubble.

The principle of the Watkin instrument is shown diagrammatically in fig. 36. The line of sight to the object passes through the instrument from a peep-sight on one side of the instrument, through a small window on the other side; the whole instrument is tilted until the top of the hill, or other object, is seen through the window. The pendulum has a

circular arc, graduated in degrees, attached to it, and this moves round close to the rim of the enclosing box. The graduations are reflected back to the eye by a small mirror opposite the peep-sight, so that the vertical angle can be read at the same time as the object is sighted. The instrument is easy to use, but its line of sight is short and its pendulum not very sensitive, and although it is possible to estimate the reading to parts of a degree, it is doubtful whether its accuracy is really better than half a degree.

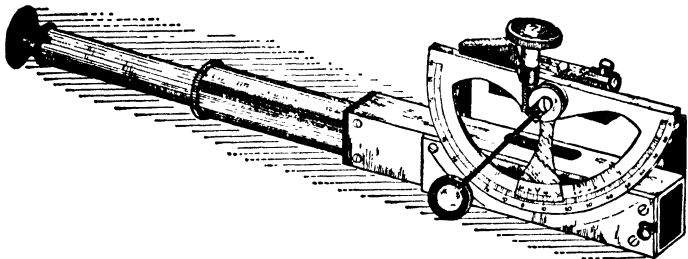

Fig. 37.—Abney Level

The Abney level, as it is usually called, is shown in fig. 37. It consists of a square tube, with a peep-sight at one end, which usually has a telescopic movement to increase the length of the line of sight. At the farther end there is a crosswire and a 45° mirror, above which a window is cut in the tube. Above the window there is a circular arc, graduated in degrees, fixed to the tube, and an index arm carrying a vernier can be moved over this arc by a slow-motion screw. Attached to the vernier arm is a small spirit bubble, and when the bubble is in the centre of its run it can be seen reflected in the mirror inside the tube. A vertical angle is taken by directing the instrument to an object, and holding it steadily so that the crosswire appears to rest on the object. The slow-motion screw is then turned until the image of the bubble is split by the continuation of the crosswire across the reflecting mirror, when the field of view appears as in fig. 38.

The angle is now "set" on the arc, and can be read by the vernier (to which a small lens is usually attached) which reads to 10 min. of arc (one-sixth of a degree). The defects of the instrument are that it is difficult to hold it steady on the object while using the slow-motion screw, and at high angles the image of the bubble is somewhat distorted. These defects are modified to some extent by resting the instrument on a rod or stick at the height of the eye, when using it, and by the fact that at angles of more than 30° there is usually much less

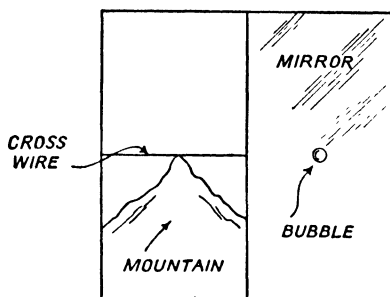

Fig. 38.—Field View in an Abney Level

need for accuracy than for small angles. For ordinary work the Abney level is decidedly superior to the Watkin clinometer.

In both instruments it is necessary to see that the index of the moving part, pendulum or bubble, coincides with the zero of the graduated arc, for which purpose an adjustment is provided. A test for what is known as the "index error" should always be made before using a new instrument, and the simplest way of carrying out this test is by what may be called the reciprocal sights method. Choosing two marks about 50 yd. apart, such as two posts of a fence, the instrument is rested on each in turn, and the vertical angle of each is read from the other; this should, of course, be the same, one being an elevation, and the other a depression. If the index of the bubble or pendulum is in error, the readings

will not be the same, but as in fig. 39, where the zero is shown as tilted upwards from the eye end of the instrument. In tilting each way in turn, the tilt of the bubble is shown by the discrepancy between the readings, and, as seen from the figure, the index error is half of this discrepancy. If the index error is a matter of only a part of a degree, as will usually be the case, it is better not to attempt to adjust the instrument, but to note the value of the error, and apply it, with the right sign, to future angles. If it is a matter of a degree or two, the

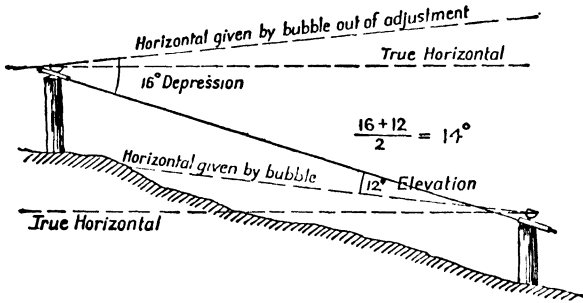

Fig. 39.—Testing for index error

adjustment is made. In the case of the Watkin clinometer this is done by moving a screw in the pendulum, which alters its centre of gravity; in the case of the Abney level, by moving the small screws at either end of the spirit bubble, which tilt it one way or the other. Frequent adjustment of these screws is not good for the instrument, and it is preferable to be satisfied with a small index error, rather than to strive after absolute adjustment by much tinkering with the screws.

It is recommended that the beginner should practise with these instruments on the heights of simple objects such as trees and chimneys, before proceeding to use them for actual survey work, and a few hints on such preliminary work may be inserted here.

If the base of the tree or chimney can be reached, then the

simplest method is to use the fact that a 45° angle of elevation gives a ratio of 1 : 1 between the two sides of a triangle. The Abney level is set at 45° , and the tree is approached gradually, until its top appears to rest on the crosswire, while the bubble is split by the same line: the distance from that point to the base of the object is then the same as its height. Or we can use a triangle which gives us a ratio of 1 : 2 between its vertical and horizontal sides, that is, we can set the arc at $26\frac{1}{2}^\circ$, and find a spot where the tree top and the bubble both rest on the crosswire; then the height of the tree is half the distance to its base. If the base of the tree is inaccessible, we can combine the two latter methods, finding points in line with the base of the tree which give respectively $26\frac{1}{2}^\circ$ and 45° angles of elevation; the distance between these two points will be the height of the tree. Since we have taken our angles standing up, we have to add the height of the eye, about 5 ft., to the height of the tree, and if the measurements are on sloping ground, we must add or subtract the difference of height between the base of the tree and the point of observation. Other methods of finding the height of such objects can be devised from the principles mentioned later in this chapter.

In finding heights by vertical angles we are really solving right-angled triangles, in which the sides represent, respectively, the horizontal distance from the place of observation to the hill or other object, and the vertical height of the hill. If we know the horizontal distance, and ratio of the vertical to the horizontal sides proper to the particular angle of elevation, we can solve the triangle, for then:

$$\frac{\text{height}}{\text{Horizontal Distance}} = \frac{h}{\text{H.D.}} = \text{ratio of sides,}$$

whence $h = \text{H.D.} \times \text{ratio.}$

Fig. 40 illustrates this with the "Scale of Shadows" as used on mediæval instruments.

The ratio of vertical to horizontal sides depends only on the

angle, and is known as the tangent of that angle; these are tabulated in mathematical tables of tangents, as decimals. The operation of calculating a vertical height therefore consists in looking up the decimal figure appropriate to the angle of elevation, and multiplying it by the horizontal distance. The tangents are so frequently required that a table of them, to every 10 min., is printed at the end of this book.

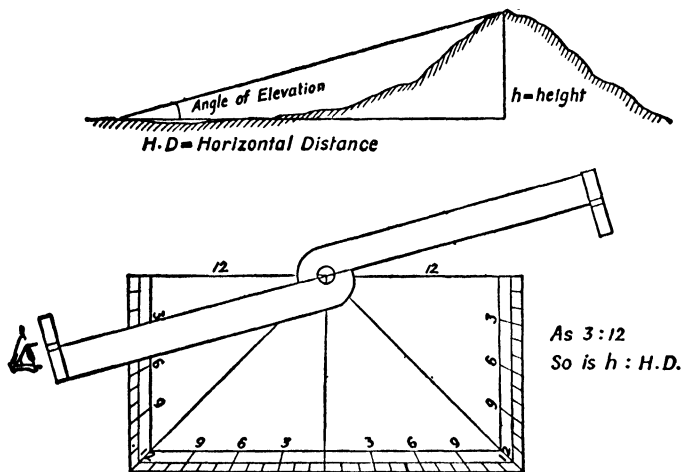

Fig. 40

For rough and ready calculations, when tangent tables are not at hand, the following simple rule will be found useful, and it is easily remembered from the figure. The tangent of 1° is $\frac{1}{60}$, or more accurately $\frac{1}{57.3}$. From this as a starting-point, we can compile a table as follows:

Tan of 1° is 1 to 60, nearly,	
2° „ 1 to 30, „	
3° „ 1 to 20, „	
4° „ 1 to 15, „	
5° „ 1 to 12, „	
6° „ 1 to 10, „	and so on.

For angles greater than 12° the table is not trustworthy, since

tangents do not increase in arithmetical progression, as is assumed in this table, but so many of the slopes met with in ordinary survey work are less than 10° that the table is quite useful.

As mentioned above, the relief of a map can be shown either by spot heights (dots on the map with heights in figures beside them) or by contours.

It should be clear now that spot heights are easily inserted on maps, provided that the horizontal distances can be obtained in some way. There are various ways of going to work, and the method suggested in the following paragraphs can be modified to suit other conditions.

We will suppose that it is desired to add spot heights to the compass sketch map outlined in Chapter V. Since it is as well to have our figures referred to the common datum of all other maps, the height of mean sea-level, we first look for a bench mark left by the official survey. As shown in fig. 41, this consists of a broad arrow below a horizontal line, the whole design being cut into the wood or stone of posts, buildings, &c., near ground-level. The actual value of the height above sea-level of the horizontal line can be found from the 6-in. map of the district, printed alongside the conventional sign for the bench mark. If no bench mark is available, then a datum must be assumed for the first mark sighted.

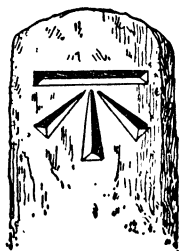

Fig. 41.—Bench mark on stone post

Since the bench mark is usually not clearly visible from a distance, it is best to find at once the height of the most prominent high object in the area, say a tall chimney, and thereafter use it for sighting. We place ourselves at a known distance from the bench mark, and take a clinometer angle; this gives us the height of eye at the station, and the ground height will be 5 ft. lower. (It is to be noted that the methods in use do not justify the use of decimals of a foot for the heights.)

From the same station we take a clinometer angle to the prominent chimney, and scaling off the distance from the map, calculate the height of the top. Thereafter, whenever we find our position on the map by resection, we can take a clinometer sight to the chimney, and find our eye height from it, subtract the 5 ft., and enter the ground height in figures on the map. The base of some of the objects which are fixed by intersection, and are not actually visited, can also be viewed with the clinometer, and the ground height entered on the map.

After a time there will be a sufficient number of spot heights on any one section of the area to allow of contours being interpolated; this should be done in the field.

On a traverse the same procedure can be followed, but as spot heights along a route do not lend themselves to interpolation by contours, the next method of plotting contours is a particularly useful variation.

The objection to surveying contours by spot heights is that it involves many measurements of horizontal distance, and minor calculations of heights. For much of the map work required by geographers some more rapid, if less exact, method is desirable, and this may be called the "slope method". In this case we measure the slope of the ground, and having calculated how far apart the contours will be for that slope, we enter the distances between the contour lines directly on the map. An example will perhaps best explain the procedure. We will suppose that the vertical interval chosen for the contours is 50 ft.; we can then construct a little table as follows:

A 1° slope gives a horizontal distance				
	between contours of	60 × 50 feet =	3000 feet or 1000 yards
2°	"	"	30 × 50 "	= 500 "
3°	"	"	20 × 50 "	= 330 "
4°	"	"	15 × 50 "	= 250 "
5°	"	"	12 × 50 "	= 200 "

and so on.

We will suppose that in our compass sketch survey we are on the side of a hill, and desire to sketch the contours more rapidly than by interpolation. Fixing the height of our own station, we find it to be 230 ft. Taking a clinometer reading the steepest way down the hill, in direction I, we find the

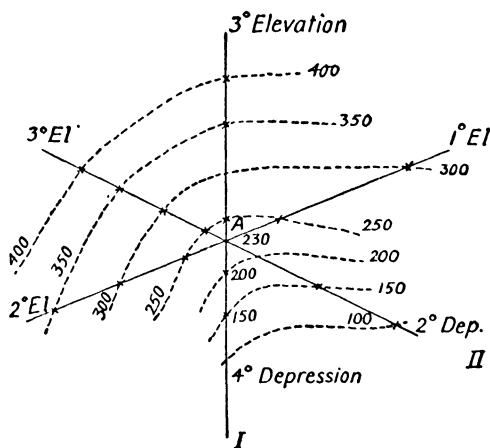

Contours by the slope method

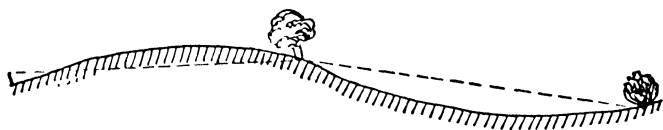

Fig. 42.—Estimating the average slope

slope to be 4° , the angle being taken by sighting along the slope at head height above the ground. A line is drawn on the map in the direction in which the angle of depression was taken. The station height being 230 ft., the next contour below it will be the 200 ft. Referring to our table, we can calculate mentally that a drop of 30 ft. will, for a 4° slope, take $15 \times 30 = 450$ ft., or 150 yd., and the full contour interval will be 250 yd. We scale off these distances along

the line, and make marks, labelling them with the contour value. The slope seems to change about 400 yd. down the slope, so we only mark the 200 and the 150 ft. contours. We do the same thing in the direction A II, and for the 2° slope along that line we mark in the 200-ft. contour at 300 yd. from A, and the 150-ft. contour at 800 yd. Sights are taken in other directions, until a number of contour crosses are made, when the full contours can be drawn in. Should the angle of slope change distinctly not very far from the station, then it will be necessary to go to the change of slope, and make another station there. In practice it is possible to estimate an average slope for a mildly curved profile, as in fig. 42, and set the contours rather closer as the slope gets steeper. A combination of this method with interpolation between spot heights is generally desirable, depending on whether the slopes are reasonably uniform or not.

In the case of a traverse, the same principles can be used, but as the map is not plotted in the field, it will be necessary to enter the bearings and vertical angles clearly in the notebook. Sketching of form-lines in the traverse notebook round each station where such observations are taken will greatly facilitate the plotting of the contours afterwards.

Levelling

The third, and by far the most accurate, way of finding differences of height is by the use of a level and a graduated staff. Since this is the method used by civil engineers for road and railway construction, its inclusion in this book perhaps needs some justification, even though the instruments recommended are very different in precision and ease of handling from those of the professional leveller.

The student of land forms is often particularly interested in the profile of a piece of ground, and the key to its study may lie in small differences of slope and height, which would be missed by any other means of measurement than levelling, and do not appear in published maps. As instances we may

quote the profile of beaches, changing with each storm, the profile of sand-dunes, or even of sand-flats in an estuary. These are all changeable in outline, and are very special cases; for more permanent features we may refer to raised beaches and river terraces, where not only are the heights above some datum important, but also the profile leading to them. To the geologist, again, small differences of height are occasionally of prime importance.

Ability to make fairly accurate sections, over short distances, will occasionally make a great deal of difference to the

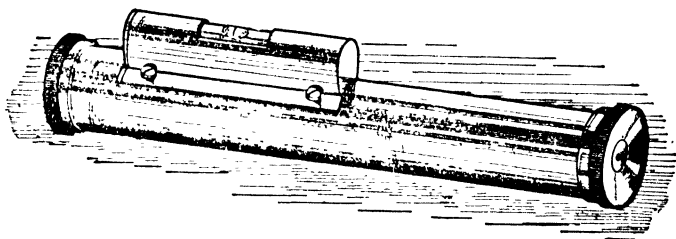

Fig. 43.--Hand Level

work of a scientist in the field, and since the work is as simple as the instruments required, the procedure is outlined below.

If an Abney level is set carefully to zero, and a sight is taken with the bubble central on the mirror, we shall be looking along a level line, and have an instrument approximating to the civil engineer's tripod level. Or, since the zero is liable to be shifted by accident, we can purchase a "hand level", sometimes known as a "reflecting level", which is really exactly the same as an Abney level, except that there is no moving arc, and the spirit level is screwed on to the sighting tube above the 45° mirror. With precautions against any possible movement of zero, the Abney level is capable of just as accurate work as the hand level.

If the level is rested on a 5-ft. stick, with the bubble central, a graduated rod held upright at some distance can be sighted,

and the graduation on which the crosswire rests can be read. Since the sight line is a level line, the reading on the staff, which is graduated from the ground upwards, gives us the height above the ground of the level line, or the "height of instrument", as it is usually called. Further, if we subtract the 5-ft. of our resting rod from the reading on the staff (6.5 in the figure), we find the difference in level between instrument station and staff station, 1.5, and finally, if the instrument is known to be on a point, say 100 ft. above sea-level, the staff station is 98.5.

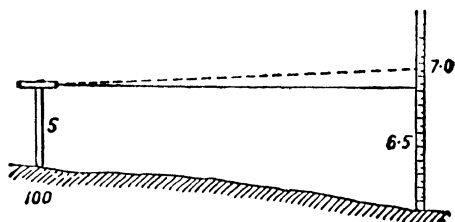

Fig. 44

At first sight it would appear that we might use this method for levelling, the instrument being moved forward to the staff station, and the staff forward again along the route. But such a procedure would soon accumulate an error which would render the levelling useless. With small hand instruments, such as a hand or Abney level, it is difficult to adjust completely for zero error, and the "level" line given by the instrument is not really level but is inclined up or down. If, as in the extreme case of fig. 44, the lack of adjustment caused the sight line to be inclined upwards, the reading on the staff would not be 6.5 but greater, say 7.0, and we should have an error of half a foot. Moreover, at each move forward we should have an error similar in sign, and greater or less than half a foot for longer or shorter sights respectively. The error would thus be cumulative, and soon become intolerably great.

What is required is some method by which the inevitable error of level in the sighting line shall be neutralized. This is achieved by sighting alternately backwards and forwards to the staff, and at equal distances from it. The procedure is shown in fig. 45. The staff is first set up at the starting-point on the 100-ft. mark, and the instrument taken forward. A "backsight" is then taken to the staff, and our assumed zero error gives us a reading of 2.5, although, as shown in the figure, the correct level line would give us 2.0. The

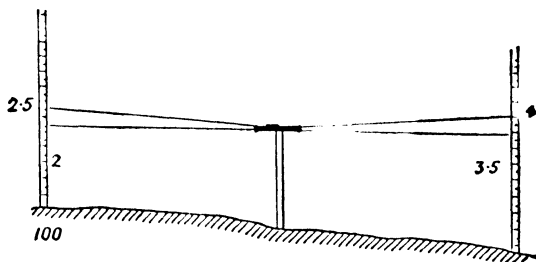

Fig. 45

staff-holder then paces up to the instrument, and an equal number of paces beyond, setting it up again on the line of section. The instrument is then turned forwards, without shifting the position of its resting rod, and a "foresight" is taken. The correct reading would be 3.5, but as the sight is the same length as the backsight, the error is the same in amount, and the actual reading is 4.0; the difference between the backsight and foresight gives us the true difference of level between the staff stations, the errors at each end neutralizing one another. This procedure gets rid of our chief difficulty, uncertainty as to the correctness of our level-line.

It is as well, however, to keep the "error of collimation", as it is called, within reasonable proportions. The method of finding its amount is as follows. The instrument is set up on the first staff station, resting on its 5-ft. rod (or rod of

any length convenient to the stature of the user), and a reading is taken to the staff at the second staff station. We will suppose this reading is 7.0 ft., giving a difference of level of 2 ft. between the stations. But we have just determined that the true difference of level is 1.5 ft., so that we know our instrument is reading high. An error of half a foot in a double-length sight is not very serious, but if it were 3 or 4 ft., it would be as well to adjust the instrument; this would be done by altering the setting screws of the spirit bubble, until a sight from the station gave approximately the reading it should be, namely, 6.5 ft.

Certain features of this, the regulation method of levelling, call for remark. In the first place, the height of the ground where the instrument rests does not come in at all, and it is the staff stations only which are determined: the staff, therefore, is always set up on the line of the section, and as frequently as the profile of the ground requires; the instrument, on the other hand, need not be on the line of section, but can be at either side, the only requirement as to its position being that it should be equi-distant from the staff stations. In the same way, the height of the rod on which the level is held does not come into the calculations, but it must remain the same for any one pair of sights.

For finding merely the difference of level between one point and another no distances need be measured, except the pacing of the staff holder to and from the instrument for each pair of sights. If a section, or profile, is to be plotted, however, the distance between the staff stations must be measured and booked.

In the alternate moving of the instrument and the staff along the line to be levelled, it is clear that the one which stands fast while the other moves must be carefully kept in the same position. For the same reason each must be rested on hard ground, so that it does not sink in between the two sights; for soft ground or sand a flat piece of wood can be carried, on which to rest the staff or instrument rod.

The staff should be at least 8 ft. in length, preferably 10 ft. in two hinged sections of 5 ft., and should be graduated in feet only, in different tints for each foot, the readings being estimated to tenths of a foot, if necessary.

Now for the inaccuracies of the method. Even with the help of a rod on which to rest the level, it is not easy to keep the bubble truly central, while reading the staff; but it is simpler if the rod has a T-piece with a groove in it, in which the level is held, so that the bubble is brought to the centre by swaying the rod rather than by tilting the instrument.

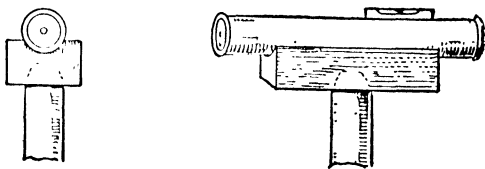
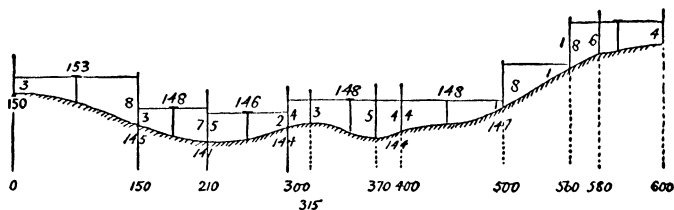

Fig 46.—Elevation and perspective of T head for the Hand Level

The errors due to inaccurate readings will, on the whole, tend to be compensating. Errors due to the rod or the staff being held out of the vertical will not be compensating, but will be small compared with the other errors, and if reasonable care is taken in holding it, no significant errors will occur. The lack of accuracy, compared with that of the professional with his tripod instrument and staff graduated to hundredths of a foot, lies almost wholly in the difficulty of holding the instrument steady. The civil engineer expects his errors to be less than $\frac{1}{10}$ ft. per mile of levelling; for hand-levelling in the method described, the errors should not be greater than two or three feet per mile.

As in the case of traversing, none of the plotting is done in the field, and it is necessary to adopt a uniform method of booking the results. The following method, though not the one in common use among engineers in England, will be found a useful one for the kind of levelling which the

geographer and geologist is likely to undertake. Fig. 47 represents the section levelled, and contains all the readings made in the field. In actual practice readings would be to decimals of a foot, but to enable the example to be followed quickly, the readings used are in feet.



Name of Levelling Section, Date etc

Backsight	Intermediate	Foresight	Height of Instrument	Reduced Level	Distance feet	Remarks
3			153	150	0	B M on gatepost
3		8	148	145	150	
5		7	146	141	210	
4		2	148	144	300	
	3			145	315	
	5			143	370	
4		4	148	144	400	
8		1	155	147	500	
8		1	162	154	560	
	6			156	580	
		4		158	600	Milestone N ^o 22
35		27		8		
		8				

Fig. 47.—Levelling Sheet and Diagram

The levelling notebook must have the columns ruled as shown, and be on ruled paper, because the system of calculation depends upon each staff station having a line to itself.

The staff is set up on the first station, the height of which is known to be 150 ft. above sea-level, and the first backsight is 3; this means that the height of instrument is 153, and that figure is written in the appropriate column. On the same line is written the height of that staff station, 150, the distance, 0, and any remarks descriptive of the station. The

staff is then taken an equal distance beyond the instrument, and a foresight, 8, is taken. If the instrument is on the line of the section, the distances paced or chained to and from the instrument can be added, and entered in the distance column. Since it is a new staff station, the foresight is entered on a new line; to find the reduced level of that station we must subtract the foresight from the height of instrument, and enter it in the Reduced Level column. The instrument is then moved a suitable distance beyond the staff station, the staff is turned round on the same spot, and a backsight of 3 is taken. Since this is the same staff station as the last foresight, the figure is entered on the same line. The instrument, having been moved, it now has a new height, which is found by adding the backsight, 3, to the reduced level, 145, of the place where the staff is being held. So the work proceeds, the actual routine consisting of adding the backsight to the reduced level of that station, to get the height of instrument, and subtracting the foresight from the height of instrument so obtained, to get the reduced level of the next station.

The use of the column for intermediate sights is made clear at the fourth set up of the instrument, any readings made to the staff at points in between a backsight and a foresight being booked in that column. Such readings will be subject to error, as they are not balanced by being paired with an equally distant reading, yet there are often points along a section line which, though not of prime importance, should nevertheless be taken to complete the section line. In this example the surveyor wants to show that the ridge between staff stations 4 and 5 is flat topped, and that in the last piece of the line there is a shoulder at 580 paces, so he finds these by intermediate sights. These levels being of a lower order of accuracy, the sights must not be allowed to affect the later ones, so they are booked as shown. Intermediates, therefore, appear in their own column, and though they are subtracted from the height of instrument to give their reduced level, they do not come into the chain of backsights and foresights.

It will be noted that the readings in the field occupy only the first three columns, the remainder being filled in by calculation. These could be left to be done afterwards, but if there is time, it is as well to do them in the field, since in that way any gross errors can be detected, such as putting a sight in the wrong column or on the wrong line. In actual practice the tenths of feet are used, so that the addition and subtraction is not so simple as in the example, and a check on the arithmetic is desirable. This is given by realizing that all the backsights can be added together and treated as one vast backsight, and the same with the foresights; the difference between them should then agree with the difference between the first and last reduced level. It is to be noted that this is only a check on the arithmetic, and not on the errors of field-work, which must now receive attention. It is easy to see that levelling is similar to traverse work, in that the error can be found if the levelling is "closed" again on the starting-point, or if it ends at a bench mark, or point whose height is known. And the assumption used for traversing, that the error is proportional to the distance, is even more true for levelling. When it is important that the levelling should be accurate, one of these two methods is used to find the total error, and it is distributed proportionately by simple arithmetic.

Although at first sight levelling appears to consist of a large number of sights and much mental arithmetic, a little practice makes one quite expert, and hand-levelling is at least four times as rapid as ordinary levelling. The chief disadvantage is that it requires the services of a staff-holder, and though he need know very little of the matter in hand, he must be able to pace evenly, and to choose satisfactory places for his staff stations.

It is now desirable to compare the relative value of these three methods of determining heights and to suggest appropriate occasions for their use.

In exploratory work, especially when a route is followed

rather than an area covered, it is rarely possible to do more than take spot heights by aneroid. This has the disadvantage that the heights can only be known where the observer has been, and the survey obviously gains a great deal if occasional clinometer sights can be taken to points off the route as well. It should be realized that spot heights alone are of comparatively small value so far as giving an idea of the relief is concerned, and it must be emphasized over again, as in the first chapter, that a little practice in drawing form-line sketches from stations will make an enormous difference to the map when finally produced. The combination of spot heights, form-line sketches and an occasional photograph will in fact give an adequate if rough idea of the country traversed, except for the "dead ground", that is, the slopes and valleys not actually viewed by the traveller or camera.

But exploratory survey over large areas is not really the subject of this book and more attention may be given to the application of the more accurate methods to small areas. To the geologist the surface relief is all-important, since upon it depend the outcrops of his strata, and a geological map has very little meaning unless the relief is shown upon it.

When it is a question of an area rather than certain special features, the clinometer method is the only one to be used, and when the map is being made by plane table it is a very easy one to apply since the horizontal distance can be scaled off the map itself as soon as any feature is entered on it, and the calculation of height made in the field.

Occasionally, however, the geologist or student of land forms is investigating some feature whose explanation or origin is definitely dependent upon small differences of level, and in these cases clinometer heights are rarely accurate enough.

The cases of sand-dunes and beach-rolls have already been mentioned, but we may add the profiles of slopes or of valley beds, the discovery of hidden shoulders or terraces, the comparison of slopes in one valley with those in another, the

relative heights of river gravels on valley sides, to mention only a few. Less often a similar accuracy in levels will be required by botanist, archæologist, or agricultural student.

For all these cases the method of "hand-levelling" with Abney level or hand level is strongly recommended. Levelling with a tripod instrument is far more exact, but it is a long operation in itself and the instruments are, by comparison, expensive. An Abney level, on the other hand, should be part of the usual equipment of any amateur surveyor, and it is capable of the accuracy required in such problems as outlined above.

Yet another rough-and-ready method may be quoted, from Africa in this case. The difference of height between the top and bottom of slopes in a river valley was required, and there was not time for detailed levelling. Starting from the bottom and resting the Abney level, set to zero, on a five-foot stick, I would send the native boy walking backwards up the slope, watching for a signal from me. As soon as his feet appeared level with the bubble I gave the signal, he then being five feet above me. The level was then taken up to where he had stopped and he backed another five feet up the slope. The method was tested on one occasion by levelling and found to be open to an error of four per cent only, if care is taken over the zero setting.

It can therefore be used for inserting intermediate contours in hilly country with some confidence and should be useful to geologists and students of land forms, who often need to find the approximate level of a stratum of rock or of a terrace. On gentle slopes the distance from the leading man's feet is apt to be too great for accurate reading.

The chief disadvantage to the "hand-levelling" method is, as stated above, the necessity for a staff-holder, and also that with the naked eye (there being no telescope in the Abney level) the sights have to be short, rarely more than 80 feet in length. The multiplicity of staff stations is, however, made up for by the fact that with practice a single sight takes less

than half a minute, and with a trained staff-holder the halts are very brief.

In the case of a profile or section the distances have to be recorded, and unless the staff stations are in a straight line, a traverse must be made of them before they can be plotted.

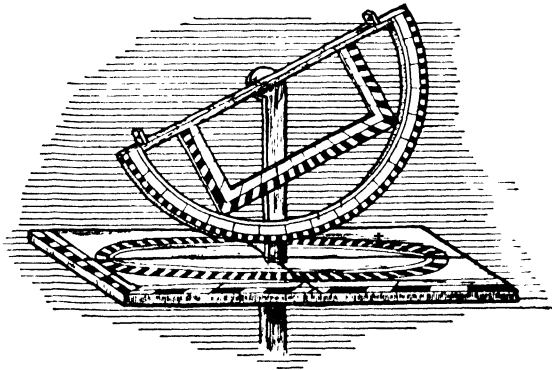

Theodolitus, 1571

Chapter VIII

THE PLANE TABLE

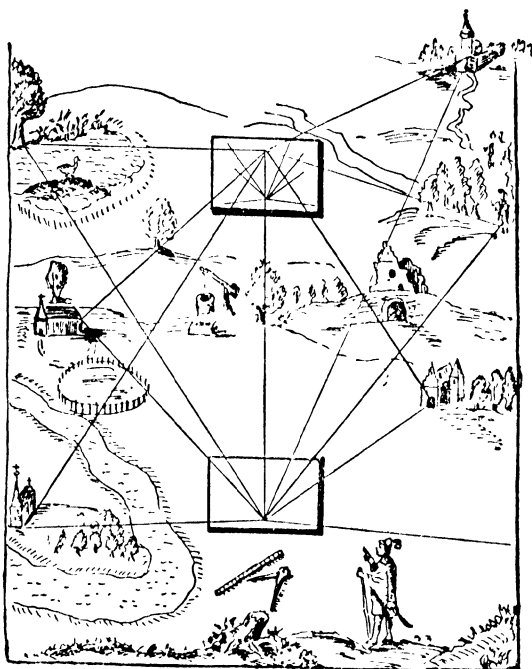

After Schott, 1660

"Onely I meane to giue a breefe Note of one kinde of plaine Instrument for the ignorant and ruder sort not inconuenient. Insteade of the Horizontall Circle vse onely a plaine Table or boarde: whereon a large Sheete of Parchment or Paper may be fastened. And thereupon in a sayre daye to strike out all the Angles of Position, euen as they finde them in the Field without making Computation of the Grades and Scruples."

DIGGES' "Pantometria", 1571.

IN this book far more space is devoted to plane-tabling than to any other method of surveying, and the reasons for that emphasis must now be stated.

In comparing methods of making maps in the field, we should naturally give preference to the one which was the quickest for a given order of accuracy, which was most interesting to carry out, which was least dependent on the assistance of other workers, and finally which was least affected by weather conditions. The method of mapping with the plane table comes easily first under all these headings except the last. Nevertheless, in spite of the fact that rain and, to a less extent, strong winds completely stop the operations of the plane-tableer, the method remains in the opinion of the author quite the most useful for surveyors of the type for whom this book is written; that is to say, for those to whom moderately accurate surveys of comparatively small areas on medium or large scales are the chief requirement.

Returning to the points cited above, we may first consider the speed and accuracy of the method, elements in a survey which are to a large extent complementary, for usually one must be sacrificed to the other. The slowest operation in surveying of any kind, and the most tedious, is the measurement of distance; but in plane-tabling this is reduced to a minimum, and indeed after the preliminary stages hardly comes into the work at all. In this respect plane-tabling is similar to Compass Sketch surveying, to which indeed it is closely allied in many other ways, its accuracy, however, being far greater, since it never relies on compass bearings. Because of this reduction in linear measurement the rate of progress in plane-tabling is high. Actual figures for rate of work would be meaningless, since they depend on such variables as scale, amount of detail, order of accuracy required, type of country, &c. It may be assumed, however, that for covering a given area it is far quicker than a series of

traverses, though it is slower than rough compass sketching.

Plane-tabling is essentially interesting to the worker not only because the map grows under his hand, but also because there are so many ways of fixing detail and carrying on the framework that the plane-tableer is constantly settling minor problems of procedure for himself. His work becomes a personal matter, in fact. Further, since the work can be broken off at any stage, and is almost free from the tedium of distance measurement, the worker can give full attention to other field interests, such as the land forms, the geology, or the vegetation of the area being mapped. No other method gives quite such a clear knowledge of the area. The work is single-handed throughout, and the plane-tableer himself is therefore completely responsible for any merits there may be in the finished map, as well as for all the errors and deficiencies.

As regards suitability for varying weather conditions, on the other hand, plane-tabling must take a lower place, and be regarded quite definitely as only a fair-weather means of surveying. The fact that the method demands that drawing paper, with all its susceptibility to damp, should be freely exposed to the heavens throughout the work makes it impossible to carry on if there is the least rain. It is true that by using special means, such as celluloid sheets, for instance, a certain amount of progress can be made in wet weather; but these are not for the ordinary worker, and will not be further considered. For really damp climates the method of traversing must be supreme, and it is also the only method for thickly wooded country, where the long sights of the plane-tableer are impossible.

The two forms of graphic surveying, namely, compass sketch surveying and plane-tabling, have an enormous advantage in one respect over all methods which involve the taking of notes in the field and plotting the map in the drawing office. Since every item of detail is plotted in the field while looking at it, gross mistakes become impossible, for they would be

detected within a few minutes of their commission. Where the items of detail are first entered in a notebook, on the other hand, especially in a traversing notebook, it may easily happen that their relative size or position may be entirely wrong owing to a lapse of attention, and the error will rarely be detected in the plotting. The best example to illustrate this point is the common error of noting down detail on a traverse sheet while looking backwards along the traverse line instead of forwards. It is very easy in such cases to insert detail and measurements on the wrong side of the line.

Enough has been said, perhaps, to put a strong case for the plane table as an instrument for the amateur surveyor, and to persuade him that he should not be satisfied until he has become fairly proficient in the use of the instrument.

Instrumental Equipment

The plane-table's equipment cannot be called elaborate, though from its nature it is somewhat awkward even if light enough for ease of transport. It consists of a tripod on which is fixed the plane table itself (similar in appearance to a drawing board) in such a way that it can be rotated centrally on the tripod and clamped firmly at any setting. On this the drawing paper is firmly fixed, by means to be detailed later. The sighting of objects and ruling of directions or "rays" is done by a sight rule or alidade. This can be had of several patterns, the simplest consisting of a ruler with sight vanes at each end, similar to fig. 48. A very useful, but not absolutely essential, accessory is a trough compass, consisting of a long compass needle in a metal box with parallel sides. These items, together with a fairly hard pencil and a rubber, complete the field outfit. A waterproof cover for the table is a great convenience for uncertain weather; this can be made of light American cloth and hemmed with elastic cord, so that it can be fitted quickly and securely over the table. Another home-made attachment which is worth providing is a strip of very fine emery cloth, or other rough material,

pasted to each leg of the tripod. The accuracy of the map depends so much on fineness of line, that is to say, on the pencil being constantly sharp, that some quick means of putting a fine point on the pencil is essential for good work. The plane table itself, when on the tripod, is precisely what its name implies, a table on which are drawn straight lines in the field as a means of fixing irregular detail, which in its turn is also drawn in the field.

A few preliminary hints as to the best design for these

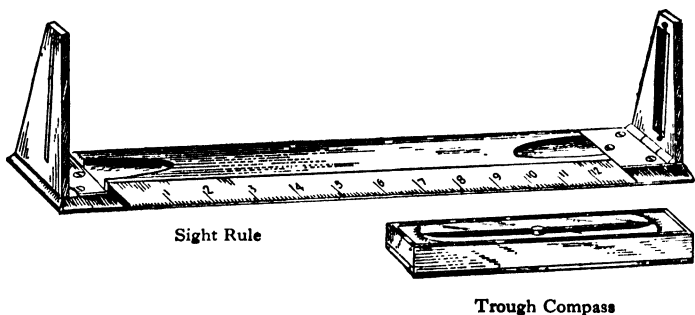

Fig. 48

purposes are advisable at this point; further remarks will be found in the chapter on Instruments. The tripod, for instance, must be fairly sturdy, for although the worker does not press heavily as he draws, he must at least rest his forearm on the board. The author much prefers a tripod of the single-leg pattern in preference to the folding leg for this reason; but for ease of transport in awkward country it may be necessary to use the folding-leg tripod. The usual method of clamping the table is by a central screw, the table itself having a metal ring which slides over a hard surface at the top of the tripod. Actually, for ease and firmness of clamping, it is much better to use the principle, common in stand-cameras, of two rings, one on the camera and one on the tripod clamped together radially. This is preferable partly because of the excessive

strain on the single central screw of the usual pattern, but also because a slight touch on the edge of the table may destroy the setting by disturbing the clamping screw, a thing which could not happen with the radial form of clamp.

The alidade, or open sight-rule, is used for sighting to an object and ruling the ray. Since the table must be set at a height convenient for drawing, the operation of sighting through the vanes involves stooping, and on this point a hint

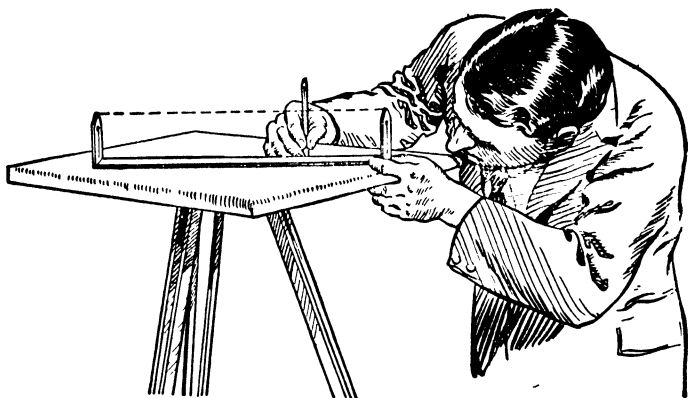

Fig. 49.—Correct attitude for taking a sight

is well worth while. Beginners usually place themselves facing the object sighted and stoop by bending both knees, thereby lowering the whole body in a strained and awkward position. A much better way, which requires very little practice to become automatic, is to stand sideways to the object sighted, which should be on the right hand, and to bend the upper part of the body over and view the object sideways through the vanes. Though we are accustomed to hold our heads upright to look at any object we can see it just as clearly with our heads on one side, and a little practice in this way will avoid much fatigue in the end. Further, it leaves the body in the correct position for ruling the ray immediately after sighting the object.

With the open-vane type of alidade a difficulty arises in very hilly country, in that sights to objects much above or much below the observer are beyond the range of the vanes. This difficulty may be partly overcome by stretching a thin thread from one vane to the other at the top so that it is taut

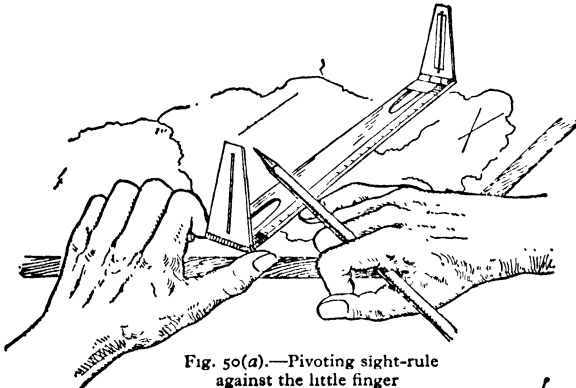

Fig. 50(a).—Pivoting sight-rule against the little finger

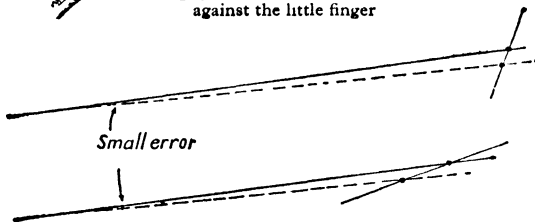

Fig. 50(b).—Diagram to show that the displacement of an intersection due to a small error is much magnified with a bad intersecting angle

when the vanes are upright. This device must be regarded as a palliative rather than a remedy, for accurate sights cannot be taken with it, and if the points sighted are of real importance some other station must be occupied more nearly at the same level. The ray to be drawn along the sight rule is to emanate from a point on the table representing, usually, the position of the table itself. Sighting an object, therefore, consists essentially of pivoting the sight rule on this point and rotating it until the object is seen through the vanes. This

pivoting requires a little practice since, when the sight has been made, the rule should be just clear of the point marking the station, so that the pencil drops naturally on to it preparatory to ruling the line. The old, and thoroughly bad, method of sticking a pin in to mark the station, against which the rule is rotated, cannot be countenanced for a moment. The best way of fixing the ruler over the point is to hold the butt end of the pencil, which, if round, should be cut to an angle like the hexagonal type, on the station point itself. The sight-rule is then pointed so that it is to the right of the object to be aimed at, and can be rotated to the left against the edge of the pencil. Skilled plane-tableers use the nail of the little finger in the same way, the object being to provide something firm against which to rotate the rule and to leave the rule in such a position that when the sight is made the point representing the station is just clear of the edge of the rule.

With these preliminary hints in mind, we may now consider the principles underlying the method of plane-tableing.

The Principle of Orientation

When we are identifying features in a landscape from a map held in our hands, we automatically turn the map so that the lines on the map between our position and the features in view coincide with the corresponding lines in nature. The map is then said to be set, or orientated. We could do the setting with more accuracy by pinning the map down to a plane table and taking it to some place, such as a road junction, which is already marked on the map. The sight-rule would then be laid carefully along the line on the map, joining our road junction and some distant and visible feature in the landscape, such as the spire of a church. The table would then be unclamped and turned until the sight-rule was pointing in the direction of the church, and a final setting would be made by looking through the vanes of the sight-rule and turning the table until the vertical wire of the vane intersected the spire of the church. If this operation were care-

fully carried out the map would be set, and its setting could be checked by laying the sight-rule over our "station" and any other feature on the map, when the vertical wire should then intersect the actual feature itself. The fact that the line between the two vanes is not the same as the edge of the rule which is set against the features marked does not really affect the accuracy of the setting, since the half inch or so of off-setting—technically known as parallax—can produce only an insignificant error for all normal sights.

We will now suppose that some feature seen from our position, such as a factory chimney, is not marked on the map and that it is desirable to enter its position. Pivoting the sight-rule with pencil or finger on the cross roads and sighting the chimney with it, we can draw a thin pencil line or ray on the map which will then indicate the *direction* of the new feature, which must be somewhere along that ray. We could then take the plane table to some other point recognizable on the map, orientate it as before on the church, and draw a second ray to the new chimney which, by intersecting the first ray, will give its *distance*, and we have now fixed it as to position. The procedure is so similar to the intersection method in compass sketching that no further comment is necessary, except to say that its accuracy should be much greater, since it is independent of the vagaries of the compass needle.

If the plane table had not been carefully set at each station the intersection would not give the correct position of the chimney; in fact the correct orientation of the table is a vital consideration in plane-table work and must be the object of constant care. Clearly the intersection will be most satisfactory if the rays cross each other nearly at right angles, and much less so if they cross obliquely. The nature of the intersection in fact requires a little consideration. Fig. 50 (b) shows how a similar error in one of the rays of both a good and a bad intersection will produce a very different magnitude of error in the intersection itself. But even should the intersection be a good one, there is no certainty of its accuracy

until it has been checked in some way, and this is done by intersecting the point, sooner or later, from yet a third position. The result of a three-ray intersection is either to confirm the two earlier ones by passing through the same point, or to give a small triangle, which can be called a "triangle of uncertainty". (N.B.—It is not the same thing as the Triangle of Error in the operation of Resection.) This small triangle may mean that one, or two, or all three of the rays were slightly in error due to faulty orientation. The proper position of the point may be at one of the three intersections, or it may be at none of them. If the point is one of considerable importance we should have to repeat the work until the three rays intersected in a point. Very often, however, if the feature is of minor importance and the triangle of uncertainty is a small one, the centre of the triangle can be taken as representing the position.

The above introduces us to an important characteristic of points in plane-tabling, namely, that they vary in accuracy, and it is extremely useful to know the order of accuracy of any points which have been fixed. To achieve this the convention mentioned in the chapter on compass-sketch surveys is recommended, that is, all points are divided into three classes, first, second and doubtful. The first-class points, which are perfect three-ray intersections, are marked by drawing a small triangle round the point. The second-class points, which are given by rather oblique intersections, or by small triangles of uncertainty, are marked by surrounding the point itself with a small circle. Doubtful points are not marked at all, but the rays marking the probable position are left in pencil until they can be turned into second-class or first-class points by further rays.

In using an existing map as a framework by which to add further detail on the plane table, we have followed the usual practice of the professional plane-tableter in a survey service, except that in his case the known points are fewer but are designed especially so as to be easily visible. His framework

usually consists of a series of "trig" points fixed by a theodolite triangulation and carefully plotted on his sheet before he goes into the field, the points usually being cairns or beacons of some kind in prominent positions on the hills, which will serve precisely the same purpose as the church or the cross roads of our map. Actually, he rarely visits the "trig" points themselves, since most of his work is done by the process of resection, which will be described later.

In the case of the amateur surveyor, on the other hand, it often happens that a map of the area is not available, or is of much too small a scale, or, more often still, that the points on the map are not suitable as marks to be sighted with the alidade. Under such circumstances he will have to provide his own framework, and this is done by a process of triangulation very similar in principle to that of theodolite triangulation. The provision of a framework is, however, rather a tedious business, and should be avoided wherever possible by the use of any professional map of the area. For the beginner, in particular, there can be no better practice in plane-tableing than to add detail to an existing map, if there is one of large scale available, and thus relieve himself at first from the difficulties and uncertainties of a framework made by himself. Even if the scale of the map available is too small, it is worth while enlarging it to the scale of his plane-table map, and this will not be a long business since only the points which are clearly visible and can serve as marks require to be put on the sheet.

Whilst speaking of scales, it is as well to realize that the plane-tableer usually works on a comparatively large scale, that is to say, from 1 : 20,000 up to larger scales still. Plane-tableing on scales such as 1 : 100,000, or smaller, is a business for the expert, partly because of the length of the sights to be taken, and partly because the detail must be drawn very carefully indeed at such small scales, and fineness of line becomes absolutely essential. The type of surveying for which these chapters are intended will usually involve scales

between 1 : 20,000 (nearly 3 in. to the mile) and 1 : 1000 (about 5 ft. to the mile), a range of scales well suited to the plane table. Incidentally, the plottable error if taken at .02 in. will represent distances on the ground from about 30 ft. for the smaller of these scales down to $1\frac{1}{2}$ ft. for the larger.

Before going into the details of plane-table practice, it will be useful to consider the kind of operations which can be

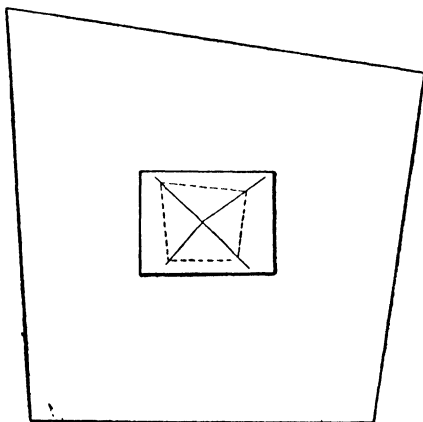

Fig. 51.—Drawing represents a field with a plane table in the centre of it to a much greater scale, and rays drawn on it

carried out with the instrument, setting them out in a list which will include all the possible types.

The equipment permits us to set the table at any desired orientation, to draw any directions, and to transfer on to the sheet any measurements of distance we may make by other means.

Let us consider the various ways in which a plane table could be used to make a map of a four-sided field such as that of fig. 51.

I. *The Radial Method.*

The table might be set up somewhere towards the centre of the field and firmly clamped at any setting. From a dot in

the centre of the paper, representing the plane-table station, rays could be drawn to each of the corners. The directions of these points would then be known and to fix them the mapper could measure along the ground to the object and scale the distance off on his rays. This would be a tedious way of making a map of the field, but the operation of drawing a ray to a feature and then measuring its distance by some means is sometimes used very effectively in ordinary practice.

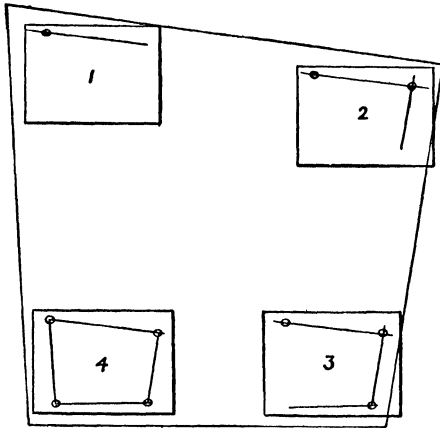

Fig. 52 —Traverse Method

II. *The Traverse Method.*

The plane table is set up in one corner of the field, set so that one side is roughly parallel to the side of the field and clamped. Some object in the next corner of the field is then selected, and a fairly long ray drawn on the sheet. Then, leaving something to mark the station, the table is picked up and the distance measured as in any other form of traverse. Arrived at the second corner the distance can be plotted by the scale, and his new position fixed. The table has now to be set to the same orientation as at the first station, and in this case it is done by the operation known as "setting by the

back ray". The table is set up level and unclamped: the alidade is then laid carefully along the ray previously drawn but with the ends reversed. The table is next rotated until the first station is intersected, and is then clamped. If a long ray is available along which to lay the alidade this method of setting is more accurate than any other. The above operations are then continued round the field. The result is a plane-table traverse, and it is open to the objection that it has involved a lot of distance measurement and the comparatively clumsy means of finding the angles by the drawing of rays.

Although the traverse method is not often used in ordinary work it may at times be very useful or even essential, especially when it is desired to map a curving boundary which is not marked by points visible from a distance.

III. *The Triangulation Method: Intersection.*

This operation is the basis of most of the work in plane-tableing, and can be illustrated briefly from the case of the four-sided field.

Somewhere towards the centre of the field a base line is

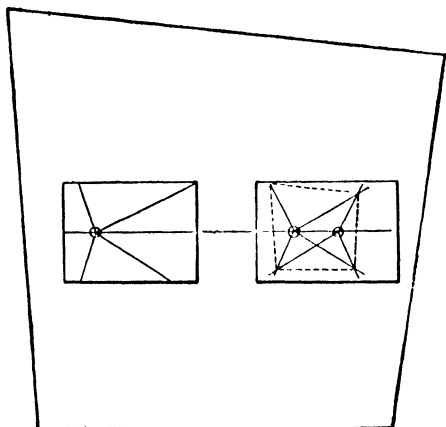

Fig. 53.—Intersection Method

selected and measured. The table is set up at one end, and after clamping it at some suitable setting the first ray drawn is to the other end of the base, adopting some point on the paper as the table's position. This ray is drawn right across the sheet. Rays are then drawn to each of the four corners. Before leaving the station, the table is checked for any accidental disturbance by setting the alidade along the first ray drawn and seeing whether it still intersects the other end of the base.

The table is then removed to the other end of the base, set by the back ray, conveniently long for the purpose, and fresh rays are drawn to the corners. Their intersections will be the map points for the corners and the map is completed, except that there is as yet no check of the work. This could be carried out by taking the table to the best intersection of the four made, setting by one or other of the base stations, and drawing a third ray to each of the remaining corners. These should pass through the intersections exactly.

We have outlined over again in this elementary way what we have already used in the comparatively rough and rapid method of compass sketching and what is, in principle, precisely what is done in the most expensive and precise forms of geodetic survey, namely, the building up of a framework of points at the apexes of a series of triangles.

IV. *The Triangulation Method: Resection.*

While the operation just described is the commonest in use in plane-tabling of any kind, it does involve a visit to two or preferably three stations before a new point can be firmly fixed. If plane-tabling consisted in variations only of the Radial, Traverse and Intersection methods, it would be tedious and require a lot of walking over the area. The last method of fixing a point, by Resection, though perhaps not the commonest, is more time-saving than any of the former. The operation would present itself in the case of the field, somewhat in this way. Let us suppose that after the map of

the corners had been made, by any of the three methods, the surveyor discovered a well or some other important but comparatively invisible point towards the centre of the field which should be included in the map. He could fix it by placing a mark over it, setting up the table again at two or more of his previous stations and treating it as another point to be fixed by intersection or measurement. But it would be very much simpler if he could, on discovering the well, set up his table close to it, and by a simple geometrical process find its position on his map and plot it without going to other stations. This process is known as Resection from three points, and will be fully described later in the chapter.

Framework by Plane Table

When the plane-table has to provide his own framework, he usually does so at the same time as he makes a detailed survey of his area. It is more convenient, however, to consider the procedure required for providing the framework alone as though he were concerned only with that.

We will imagine, therefore, that the plane-table is in country entirely new to him, and of which he can get no map which will give him the relative positions of even the most outstanding features. Let us suppose that it is a wide valley, say 4 miles in width, with individual hills or knolls along the base of the valley, the higher ground as a whole being towards the edges of his area. His purpose in such a case will be to dot over his sheet a series of first-class points in their proper relative positions which will form the control for the detailed mapping in the vicinity of each; points which, in fact, are comparable to the beer-mugs of the anecdote with which this book began. The principle involved, as stated above, is that of one base line carefully measured and a number of triangles built up on it and upon themselves, the apexes of which are fixed points of the framework. The first procedure is to choose and measure a suitable base line. In the case of a theodolite triangulation carried out professionally the base

line is measured with extraordinary care and precision, and an effort is made to reduce the probable error to the order of a few millimetres. This care over the base line, so appropriate in the case of theodolite work, is responsible for a general idea that a plane-table base line must be, if not of comparable accuracy, at least a work of great moment and calling for precise instruments. That this is not the case at all will be clear if the reader remembers what has been said about plottable error. The plane-table sheet is the sole and final product of the work in the field, and any errors made in the field endure for ever on that sheet. Consequently the plottable error, that is to say, the error which is inherent in a man's inability to draw an excessively fine line, has as direct an effect on the base line as on any other part of the survey but no more than that. It is therefore quite useless to aim at any precision of measurement in the base line which is beyond the ability of the worker to plot on the scale he is using. An example will perhaps clear up any doubts on the matter.

Taking round numbers for easy calculation, let us suppose the scale is 1 : 3600, that is, 100 yd. to the inch. Since the worker cannot by any means plot more accurately than to $\frac{1}{100}$ in., this means that he cannot put a point or end a line to a greater accuracy than is represented by 1 yd. on the ground. Supposing he measures a base line of 300 yd. for his work, he only has to ensure that his probable error in the measurement is not greater than 1 yd., an accuracy which he could get easily with a linen tape or even by pacing if he took the mean of several measurements. The first thing, therefore, for a plane-tableer to do is to realize what his plottable error is, and to make his measurements conform to it. In this way he will save a great deal of time and feel more at ease with his work generally.

The next thing to consider is the position for his base line. The work is simpler if it is towards the centre of the area, but this is by no means vital. What is more important is that

it should be so placed that the first triangles erected on it to prominent hilltops, &c., should be well conditioned, that is to say, approaching the equilateral type.

The length of the base line is another matter of importance, because the longer it is the more easily the whole area is covered with a framework; but, on the other hand, really long base lines are not always easy to find or to measure. What is more important is that the base line as plotted on the board should be of a reasonable length, that is, the length of base line is dependent upon the scale used. A useful minimum length on the board is 3 in., and the reason for the minimum can be understood by taking an extreme case. Supposing that the base line as plotted on the board is only $\frac{1}{10}$ in. in length. The uncertainty as to the ends is of the order of $\frac{1}{100}$ in., that is to say, 10 per cent of the actual base line, a very high proportion when we consider that the rays are ruled in each case from the uncertain end of this very short line. If the base line is 3 in. long, on the other hand, the uncertainty of $\frac{1}{100}$ in. for each end represents only $\frac{1}{300}$ of the line itself, a reasonable fraction.

We may now consider that the base line has been chosen, measured, and marked by a pole or stake at each end, and the plane-table goes to one end with his plane table to begin work. From what has been said about orientation it will be understood that the setting adopted for the table at the first station will be kept throughout the survey. At his first set up, therefore, the plane-table clamps his table so that it conforms reasonably with the shape of the area he proposes to cover. Having set the table to his satisfaction, he now selects a point on the table to represent where he stands, in such a position on the sheet that the area will be covered by the sheet with a little to spare. With the table clamped he now rules a ray from this chosen point to the other end of the base line, and since this is the initial setting it is as well to rule this base line direction right across the sheet and leave it there until a great part of the work has been done. Needless to say the point

representing where he is is a first-class point, and can be surrounded with a triangle at once. Since in this case he already knows the length of the base line he can measure it off with his scale and plot it even before he goes to the other end. It will already have occurred to the reader that it is advisable to have the scale drawn somewhere on the sheet towards the edge, and that it is very useful to have the same scale on a piece of Bristol board or drawing paper to be used for other measurements on the sheet.

From his first station he now takes rays very carefully to the most prominent objects within the area which are visible from his position. These rays will have to be labelled, otherwise confusion will soon arise. A pencilled description of each object is usually sufficient and preferable to having a series of letters or figures which have to be noted down in a separate notebook together with a description of what they stand for. The rays must be drawn with a really fine pencil and need not be drawn from the station of origin, but only over the approximate position of the point sighted. Indeed, the plane-tableter will soon find that unless he is moderate in the length of his rays he will quickly have his sheet looking rather like a spider's web.

The last operation after ruling the rays is the most important of all, and must be carried out at every single station in the whole survey before moving on. The whole principle of the work is that the table shall not be shifted from its original orientation; but, unfortunately, this is very likely to happen from the continual writing on, and leaning against, the table. It is therefore of vital importance to see whether it has been shifted before leaving the station. This is done by laying the alidade along the first ray drawn at that station, in this case the base line itself, looking through the sights and seeing whether the table has moved off the object sighted. If it has done so the rays must be re-drawn in reverse order from the last until the one is reached after which the table was inadvertently moved. In course of time the plane-tableter will

regard the checking of his orientation in the same way as donning his hat when leaving his house.

When setting up the table at the other end of the base line, his first object is to orientate it parallel to his last position, and this is done by the operation already referred to as setting by the back ray. He places the alidade along the ray defining the base line and pointing in the reverse direction to that used when it was drawn. With the table unclamped he rotates it until he sees the other end of the base line through the sights. He then proceeds to intersect by new rays all those points observed from the first station. The rays themselves need only be about $\frac{1}{10}$ in. long to mark the intersection clearly. He should also draw rays to some fresh features which were not visible from the first station, but will be intersected at a later stage when farther afield. Naturally those points which are in the general direction of the base line will give oblique intersections, and be unsatisfactory at this stage, and he will finish with possibly two or three really good intersections, and others varying in degree of obliquity. He now has to decide which of these points he will adopt as a third station to be visited and accepted as a first-class point. This should be a point which gives a good view, and when he reaches it he sets his table by sighting either of the ends of the base, and, proceeding as before, he gets three-ray intersections to all or most of his points.

By this time he will have a good indication as to the quality of his work, and each three-ray intersection to a well-defined point should be satisfactory in the sense that if the rays do not actually meet in a point they very nearly do so. If every one of them gives a small triangle of uncertainty, it means that one of the three orientations was at fault. It is at this stage that the plane-tableer should develop a conscience, for should he decide to include amongst his first-class points those which are not really good intersections, he will be laying up a store of trouble for himself in the future.

The third station is to all intents and purposes fixed as

carefully as either end of the base, and is the beginning of the extension into larger triangles, which is the basis of triangulation. Thus from his third station linked with one of the base ends he will have fixed one or more points which are entirely satisfactory and which, therefore, can be visited in

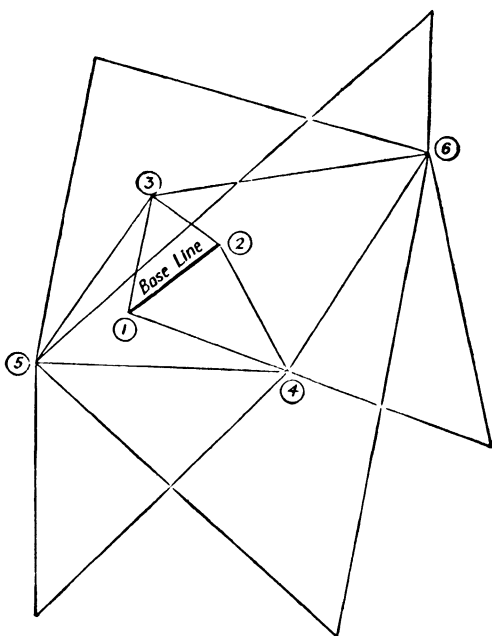

Fig. 54

their turn. If the valley is not too large he will have included in his early intersections the points on the high land at the side of his area. As soon as he has a satisfactory point at each side of the valley, he will visit them in turn and, using either as an extended base, finally fix the remaining points on the area.

The method of extending the triangles outwards from the base to cover the area is shown diagrammatically in fig. 54,

only the main triangles being shown, and a suitable order in which the stations might be visited is shown by the numbers attached to them. The shape of the triangles is, of course, determined largely by the distribution of the natural features, and it must be remembered that to be really useful the main points of the framework must be visible at a good distance. For amateur work there can rarely be the time or opportunity to set up large artificial marks such as the professional surveyor uses, and dependence upon existing marks still further limits the shape of the triangles.

Such is the general method of providing a framework for a detailed survey with the plane table itself. Later on it will be seen that the process of resection is nearly as effective as intersection for fixing a point. Each point so far is represented by three rays intersecting, and before leaving the field it is as well to clear up the board to some extent by making a fine pencil dot for each point accepted, surrounding it with the appropriate triangle or circle, and writing its name near the point. In the evening the station dot may be carefully inked in, or even pricked through with a needle; but the symbol for the station and the name are best left in pencil.

Hitherto we have not dealt with the relative heights of these points, whereas in actual practice observations to determine their height are usually made at the same time as they are fixed. If that were done the framework would finally consist of a series of dots with their heights and descriptions written close to them. The accuracy of the first-class points should be such that the thickness of the dot for any one station includes the probable error, but this degree of precision is not easy to attain all over the sheet.

Resection

The principle of resection, or finding one's own position from three known points, is in many respects the key to rapid and successful plane-tabling. Like many other operations, it can be taught quite easily by rule of thumb, in which case the

operator carries out certain processes without understanding their meaning. It would, however, be quite foreign to the idea of this little book to allow such an important section of the subject to be learnt merely as a series of rules. We shall, therefore, explain the matter at some length.

It will be recalled that resection by back bearings as used in compass-sketch surveying is done by sighting to two known points, that is to say, points already on the map, and drawing the back bearings from them to give an intersection, which gives the position of the surveyor. Let us see, therefore, what would happen if the plane-tablet at an unknown point takes directions to two points already on the sheet and visible from where he stands. He cannot rotate his sight rule on his own position since he does not know where it is; but he can pivot it upon one of the known points, sight that point, and rule a ray backwards towards himself. A similar operation for the second point will give him an intersection of two rays, and at first sight it would appear that he has done what the compass sketcher did, and has found his own position as required. To disprove this let him unclamp the table, rotate it a few degrees, and again draw the two back rays. He will then have another possible position. If he were painstaking he could go on in this way and find a whole series of points each of which might be the right one; if he were a little mathematical he would soon realize that he was merely demonstrating the theorem in geometry which states that the angle subtended by the chord of a circle is the same at any point along the arc, or that the locus of the apex of an angle subtending two fixed points is the arc of a circle passing through those two points and the apex. He thus proves to himself that he has not solved his problem, for he has only found that he must be somewhere on an arc of a circle. On the other hand, he has got half-way towards a solution since, if he takes any other two points, he can draw another arc, and where those two intersect must then be his actual position. This could be done with some trouble in the field, as shown

in fig. 55, for by bisecting the chords at right angles he can find the centre of each circumscribing circle and draw the circles, the intersection of which will be the point desired.

Therefore there must be two sets of two fixed points, one of which can be common to the two sets, before we can fix our position by resection. The reason why two bearings are sufficient to establish the position while it takes three rays

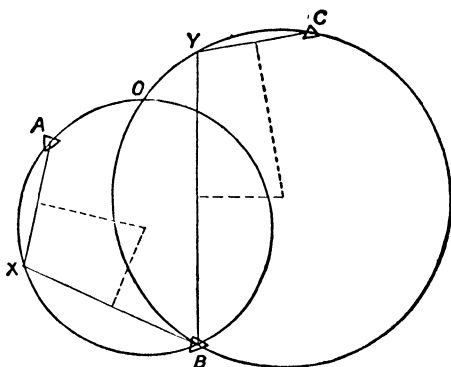

Fig. 55 --A geometrical but tedious method of finding one's position by resection. A, B, and C are the three known points on the map and visible in the field. With any setting of the table rays are drawn backwards from A and B to give the angle at X, which must be a point on the circle. By bisecting the lines AX and BX at right angles, the centre of the circle is found and the circle is drawn. A similar operation with B and C gives another circle. The point of intersection O must then be the position of the plane table.

is because each bearing is an angle, namely, the angle between the magnetic meridian and the direction of the point sighted, so that two bearings give the required two angles, whereas three rays are required to give two angles. The operation is a common one in navigation along coast-lines, but since it is done in that case by instrumental methods it is not usually realized that it is resection, and could be imitated on a plane table. When a ship is travelling along a charted coast-line, it is possible for the navigator to fix his position by taking the angles subtended at his ship between three points visible

on the coast and plotted on the chart. He can do this quite rapidly with a sextant held horizontally. He then takes an instrument known as a station pointer, which is really a protractor with three arms. Setting these arms to the two angles he has taken he lays it on the chart and moves it about until each arm passes through the respective point on the chart. The central point of the protractor then gives the position of his ship.

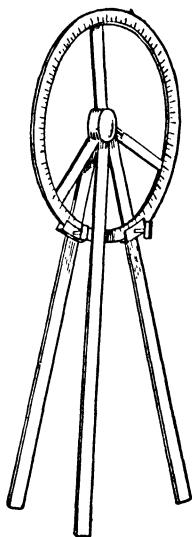

Fig. 56.—Station Pointer. Really a protractor with 3 arms, centre one fixed at zero of the circle, outside ones movable and clamped by a screw.

A similar method can be used by the plane-table, but is too clumsy for use in actual practice. Since it illustrates the theory, however, it will be described here.

Fastening a piece of tracing paper temporarily on the table, the worker makes a dot on it to represent his position, and rules three rays to the fixed points he has chosen. These rays do the duty of the arms of the station pointer. He then takes the drawing-pins out of the tracing paper and moves it about over his map until each ray passes through its respective point. The intersecting point of his rays is then his own position.

We now have two ways in which resection might be done in the field, namely, by drawing circles or by the tracing paper method, but as both of these are clumsy they are never used. It is actually better to go to work by a "trial and error" process instead, usually known as the "three point problem", and though it takes some time to explain its theory, it is fairly rapid in practice.

The problem is really that of finding the correct orientation of the table at the unknown position, for as soon as the table is correctly set the back rays from any fixed positions will all meet at one point, the required position. If the orientation is

wrong the three rays drawn backwards will not meet in a point, but will form a triangle known as the "triangle of error", the size of which depends upon the amount of error in the orientation.

We require to close this triangle of error down to a point by resetting the table to the correct orientation; and this could be done, though with much expenditure of time, by trial and error as in fig. 57, where the worker has guessed at the proper orientation, and by resection got triangle I. He

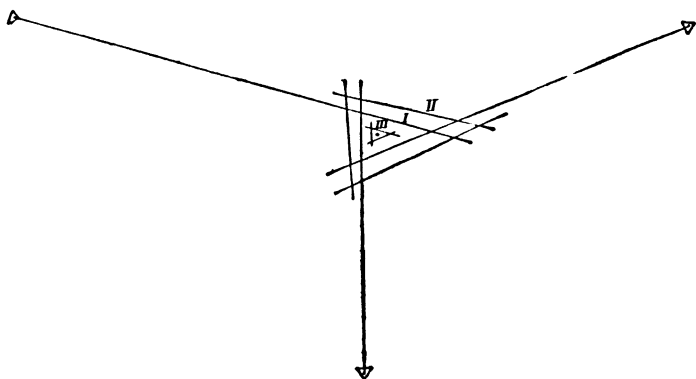

Fig. 57

has then reset the table but moved it in the wrong direction, so that his triangle of error II is larger instead of smaller. At a third trial, resetting the table in the right direction he gets the small triangle of error III, and a little adjustment gives him a final resection to the point inside it. This method would be too tedious for actual use, and what he does in practice, after getting his first triangle of error, is to make a guess, inspired by certain rules, as to where the point is going to be.

It is convenient to consider that there are two cases of the problem, and a slightly different set of rules is needed for each solution. If the position of the plane table is within the

imaginary triangle connecting the three fixed points, it is said to be Case I. Fig. 58 shows such a case, and the triangle of error made by the back rays. Our object is to close this triangle down to a point by changing the orientation of the table, and a little consideration shows that the required point will be inside the triangle of error, because for any one movement of the table the resecting rays will move in the same direction round their pivotal points, that is to say, all clock-wise or all anti-clock-wise. Moreover, the required point will be at such

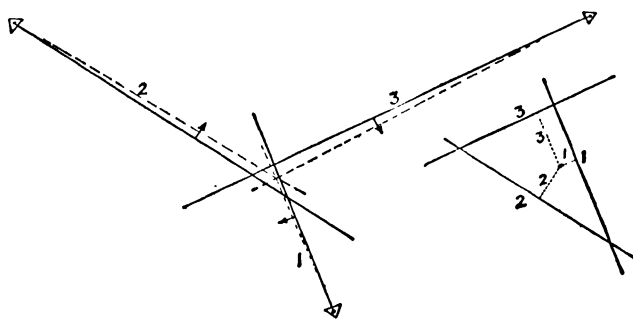

Fig. 58

a position inside the triangle of error that its distance from the sides of the triangle is proportional to the length of the ray forming that side. This, also, is mere common sense, for the longer the ray the farther it will have to swing round for a given turning of the table.

With these two rules in mind the worker can quite quickly choose a point inside his triangle of error and make a dot which can be called his trial point. He then rubs out the triangle of error and, laying his alidade over the trial point and the most distant fixed point, he unclamps the table and resets it by that ray. He draws a ray backwards which, of course, will pass through the point, and pivoting on the other two fixed points, draws rays backwards from them. These will form a very much smaller triangle of error than the

original one, or, if his estimation of the trial point has been exact, will all pass through it. If a triangle of error is still formed he chooses another trial point inside it, and the third trial is certain to bring the rays to a point, that point being his own position; in finding it he has also set the table at its proper orientation.

The rules for Case I may therefore be stated in the form: (1) the required point is within the triangle of error; (2) the

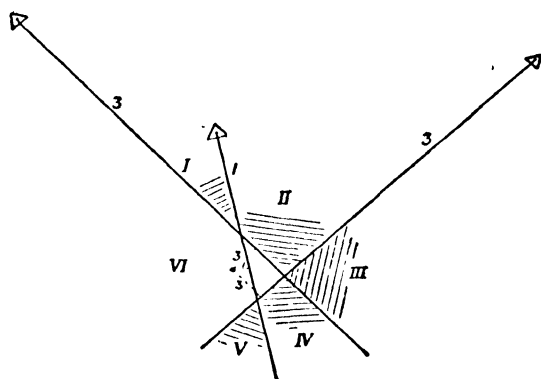

Fig. 59

required point will be at a distance from the sides of the triangle proportional to the length of the rays forming the triangle.

In fig. 58 the number printed on each of the rays is meant to give a rough proportion between the lengths of the rays; in practice this need not be reduced to a numerical figure, but merely assessed by eye.

Case II.—When the position of the plane-table is outside the imaginary triangle formed by the three fixed points we have Case II, as illustrated in fig. 59. Remembering that for each new setting the rays all move in the same direction, a little consideration or trial shows that for Case II the required point must be outside the triangle of error instead of inside; that, in fact, the whole triangle moves with a new setting to

one side or the other of its former position. This apparently makes the problem much harder, for, as a schoolboy said, "There's an awful lot of outside to a small triangle." The difficulty is more apparent than real, however, for closer examination shows that one can decide almost at once which of the six sectors made by the rays and their prolongation will contain the required point. Referring to fig. 59, it will be obvious that it cannot be in any one of the sectors marked I, II, IV and V, because if it were the rays would have to swing in opposite directions to reach the point. We are, therefore, left with III and VI as possible sectors, that is, either to the right of the bundle of three rays or to the left. But here again the problem is simplified when we remember that for any given resetting the longest ray will move the longest distance and the shortest ray the least distance. Clearly, therefore, the point cannot be in sector III, since that would mean the shortest ray moving the longest distance. By a process of reasoning far more rapid than any explanation can be, the plane-tableer sees by inspection his required point is in sector VI, and, following the former rule, is nearest to the shortest ray and farthest from the longest ray. He estimates such a point and, as in Case I, tries it by resetting until he has got the triangle of error down to a single point.

The rules, therefore, run as follows for Case II: (1) The required point is outside the triangle of error; (2) it is either to the right of all the rays or to the left of all the rays; (3) its position is proportional to the length of the rays forming the triangle of error.

These rules, which are really but corollaries of the geometrical facts, may seem confusing at first, but they can be applied and learnt without taking a plane table into the field, so that the beginner may get them clearly into his mind before proceeding to try them in practice. An example may be taken from each case to show rather unusual dispositions of the points and the application of the rules for them.

When the position of the surveyor is close to the line join-

ing two of his fixed points it will occasionally happen that he is not quite sure whether he is inside or outside the triangle formed by the three fixed points, and whether Case I or Case II applies. In such a position the triangle of error will have two of its sides converging so slightly as to be almost parallel and if the orientation is much out of truth the triangle will take a strange elongated shape. He can settle the matter quite easily by sighting on one of the two points with which he is

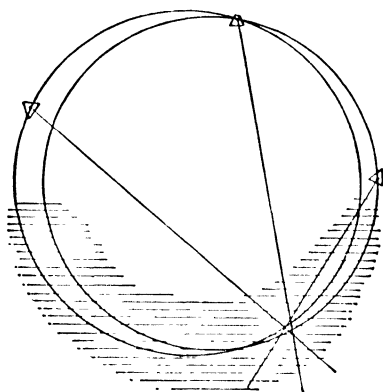

Fig. 60

nearly in line, and then looking through the alidade the reverse way. This will tell him at once whether he is inside or outside the main triangle, but the fix from such a position can rarely be a good one.

In Case II it will be found that with certain relative positions of the known points and the station there arises a certain amount of ambiguity in applying the rules for that case. In fig. 60, for instance, it is not easy to determine whether the required point is to the right or to the left of all the rays; either seems possible, and a large movement of the triangle with a new setting seems to have little effect in closing the rays to a point.

If we go back to the theory of resection and draw the arcs of circles passing through the required point and each pair of known points, the reason for this unsatisfactory state of affairs is apparent. The circumscribing circles are so nearly coincident that the intersection of their arcs is extremely oblique.

The same figure shows that when the two circles do actually coincide, that is to say, when the three known points and the unknown are "concyelic", there is no solution, for the locus of the station is then an arc of a circle. This circle is sometimes called the "danger circle", but it is more useful to speak of a danger zone, namely, the zone shaded in the figure denoting a belt where the solution is either unsatisfactory or impossible.

If there are more than three fixed points visible from the station the surveyor then takes a different set of three, but occasionally there are only three, in which case he must first establish another station not far away from which he can fix the point he requires. Inspection of the figures used so far shows that the worker can usually avoid the danger zone if he takes care that the middle of the three stations he is going to use is nearer to him than the outside ones.

It is better still to get into the habit of noting before occupying a new station for resection whether there is likely to be a good distribution of points for the purpose. It must be remembered, too, that to say that a case is insoluble means only that the table cannot be orientated by means of the three-point construction. If he can set it by any other means then he can get his position at once by the intersection of the rays, which will meet in a point.

Let us suppose, for instance, that he wishes to occupy a hill from which he knows he will have an awkward placing of his fixed points, if not an actual concyclic one. Before leaving his station he draws a ray to the point he intends to occupy, and leaves a mark of some kind behind him. From the new station he can then set his table by the back ray to

this mark and fix his position by resection from the points which otherwise would have been of no use to him.

Enough has now been said about the difficulties of resection in certain circumstances and to the beginner it may sound confusing if not actually formidable. The advantages of resection will soon prove themselves in the field, however, and a very great part of most plane table work is done by the method.

Imagine, for example, that a line which is not visible from a distance is to be mapped; this line may be a sunken water-course, or a boundary of two rock formations, or a terrace.

The plane-tableer, having established his framework, or having it already on a professional map, then goes straight to a point on his line. He resects for position, draws in the curves of the line for as far as he can see or can trust his judgment, and moves off to another point on the line. If this second point is visible from the first he should draw a ray to it before leaving his last station, as this will simplify the finding of the new position, but if, as is more usual, he does not know where his new station will be, or it is out of sight, then he resects again. It must be pointed out here that if the line being mapped is an indefinite one in itself, then much less care need be taken over fixing the stations, and the first trial point will usually be close enough for the purpose, without going to the trouble of resetting the table until the three rays intersect exactly. How quick an operation it is under normal circumstances will not be believed until it has been practised for some time; but it is obvious that a good deal depends on how large the first triangle of error is. If it is more than half an inch across then it will almost certainly take two trials to find the point with certainty.

We therefore require some way of ensuring a small triangle of error. Since its size depends entirely on the correctness of the orientation of the table, what is needed is a means by which the table can be set to within a degree or two of the right orientation each time.

This can be achieved by the use of a trough compass which is carried in the pocket as an accessory. At the first set up of the table after the orientation for the whole survey is determined, the compass is put on the table in some corner not likely to be wanted for detail and turned until the needle points to zero. The pencil is then traced round the long box, leaving a rectangle or frame on the paper. When a resection station is occupied the table is unclamped with the box compass set carefully in its pencilled rectangle, and the table turned until the needle is at zero. This will bring the setting to within a degree or so of the correct one, and ensure that the first triangle of error will be small, but it must be realized that the purpose of the compass is to reduce the preliminary work of resection, not to take its place. This warning is given since some plane-tablers are satisfied with a compass setting and an intersection of two rays only, which will give only second-class or doubtful points which cannot be used in extending the map.

It is not essential to have a trough compass; an ordinary watch type gives good results or the surveying prismatic with its lid wide open will do. The trough compass, in fact, is usually made too sensitive, and takes a considerable time to settle down when moved, giving a precision which is unnecessary.

When no compass is available the work of resection takes longer, but is not otherwise affected. In hilly country with good visibility a useful alternative to the use of a compass is to draw two or three "direction" rays to very distant objects, far outside the sheet, from one of the early stations. The rays are of course drawn at the side of the board, out of the way of the ordinary rays, when the table is properly set, and are plainly labelled. If the objects, usually distant mountains, are very far away one of the direction rays may be used anywhere on the sheet, and ensure a fairly close approximation to the correct setting.

If they are not very far away, then at any one station

that direction ray is chosen for setting which is most nearly in line with the original station where it was first drawn. Taking a simple example, if there were two such rays, one to a mountain in the north and one to the east, then when the table was north or south of the original one, the north mountain would be used, since it would give the least parallax error. This method was devised and used with success in a country where the compass was untrustworthy, being so near the magnetic pole that it differed by as much as eight degrees for two bearings of the same object.

A further advantage in using resection is that as only first-class points are used, and each resection is independent of the last, there is no accumulation of error.

It has now been shown how the plane-tableer can construct his own framework by graphic triangulation, and how, when he has provided for himself a reasonable number of first-class points, he can insert other first-class points by resection. It only remains to describe how the process is carried further, and a complete map produced in the field on these foundations.

We can imagine that the area is the same as that for which the triangulation was provided, and that the kind of detail to be fixed will be artificial features such as roads and houses, natural features such as streams and hills, and that the relief of the country is to be inserted by something less accurate than true contours and more precise than mere form-lines. In actual practice, the plane-tableer usually provides his framework and sketches in his detail at the same time; but for the purposes of description we will assume that he has the framework already provided, and that he arrives at some first-class point ready for inserting detail alone.

We will presume that he is on a hillock, point 206, not far from a river and a road, as in fig. 61. His scale is 1 : 3600, or 100 yd. to the inch. He decides to deal with the river first, which passes within 50 yd. of his position, but, as in the case of all rivers, is a rather indefinite line so far as its banks are concerned. So he does not hesitate to draw in the nearest part of

the river by estimation of the distance, placing himself so that he is facing the actual features of the river banks, and carrying his eye from them down to the board as he sketches. The second bend in the river is distant over 200 yd., but being rather ill-defined, he still feels capable of sketching it in by eye; to assist him in getting the curve in the right direction he takes a rapid sight with the alidade, and rules a little ray to which the curve is tangent. Since he can see several other curves in the distance, he rules tangents to these also. Briefly,

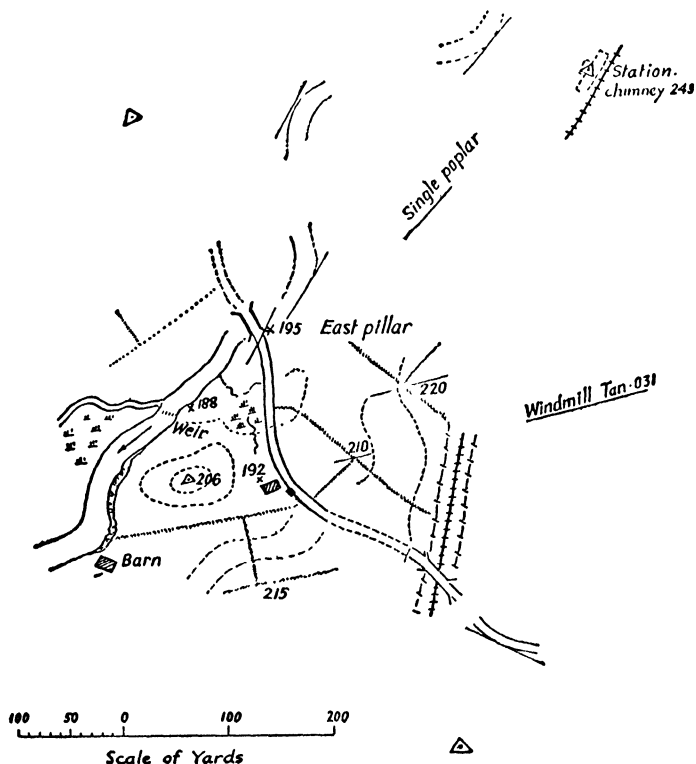

Fig. 61

he sketches in the river by eye as far as he dares trust his judgment of distance.

The case is somewhat otherwise with the road, and still more so with the railway, both of which are also close by. These are well-defined features and should be fixed with quite a different order of accuracy from the banks of the river. The road is within 80 yd., and that is a distance which the surveyor can estimate without an error of more than a few yards; if he is anxious to be more accurate than that he can pace such a short distance quite quickly. The width of the road is more important, and either then, or at some other time, he will pace that and sketch it in carefully. As with the river, he can rule tangent rays to curves of the road. The bridge is a particularly important point and, as it is over 100 yd. distant, he will probably rule a ray to some part of it which he can visit. The fact that this ray crosses the river already drawn may be considered sufficiently accurate as a fix in some cases.

The same procedure is followed with regard to the railway and the bridge where the road crosses it. He takes his time over this sketching, and carefully avoids the besetting sin of the beginner, which is that of scribbling down his detail with a vague idea in his mind that it can be made neat when he inks it in.

After sketching in all the detail he thinks necessary, including the corners of fences near him, positions of gateways, &c., he decides that he has got as much detail as he can expect to get from that station. Knowing that he is going to visit the bridge station next, he will probably draw a few rays to fences, gates and buildings for which he will be able to get an intersection from the bridge. He should now make some measurements for height to guide him in putting in the relief. For his vertical angles he may use the Abney level, as described in Chapter VI. If he is suitably equipped, however, he will have with him a special instrument known as the Indian clinometer (see fig. 62). It consists of a base on

three points which rest on the table. Above that is a horizontal bar hinged at one end and supported at the other by a thumb-screw which, resting on the base, will raise or lower that end of the bar to get it truly level. In the centre of the bar is a small level bubble. The vanes at the end of this bar consist at one end of a simple vane with one peep-sight, and at the other end of a large vane with marks on either side: these represent degrees of elevation or depression on one side and on the other side the corresponding natural tangents. Looking through the peep-sight, when the bubble has been brought to the centre of its run, the eye, when looking at the zero mark, is looking

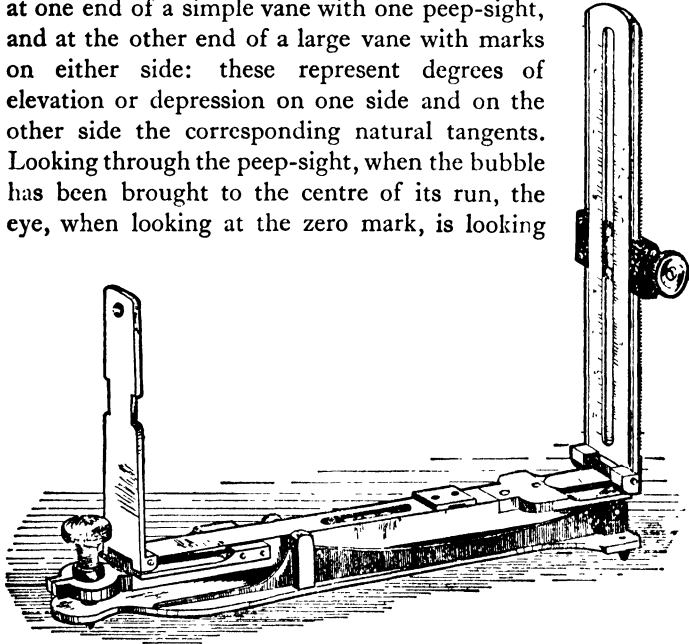

Fig. 62.—Indian Clinometer

along a level line. When sighting to the top of a hill the line of sight passes one of the figures representing the angle of elevation, which can be read off at the same time as the hill is sighted. In some patterns there is a little cursor with a horizontal cross wire which can slide up and down the vane. To use the instrument it is laid on the table pointing in the direction of the feature whose elevation or depression is to be measured, and is levelled by using the thumbscrew.

The sight is then taken and the natural tangent written down on a spare piece of paper. The cardboard scale is laid along the line between the station occupied and the feature and the distance read off. (Since heights are always given in feet in our maps, there should be a scale of feet on the cardboard.) This distance is multiplied by the tangent and the difference of height between the plane table top and the feature is thus obtained. Allowance for the height of the table is made when writing down the final height on the sheet. For each fresh direction the instrument must be re-levelled as the plane table itself will not be truly level. It should be clear that the shorter the distance to the object sighted the greater the accuracy.

Let us suppose that the plane-tableer does not know the height of his present position, but that he does know the height of the Station 550 yd. away, which is already a first-class point, namely, 249. Sighting on this point with his clinometer, he finds the tangent of the angle of elevation to be $\cdot 024$. Multiplying this by the distance in feet he finds that the difference of height is 40 ft. This being measured from the top of his table, he subtracts another 3 ft. and writes down on his sheet the figure 206. He now takes similar angles of elevation or depression to various objects near him and works out their difference of height from the top of his table, writing them in alongside the point sighted on. These objects may be quite unimportant in themselves, such as the base of a tree, a boulder, a tuft of grass, and it is a useful convention for such temporary points, used only for heights, to make a little cross alongside which the height is written in. He ends by having five or six spot heights written on his sheet in the vicinity of his station. He can then follow one of two courses. He may either draw in his final height lines, interpolating them between the heights he already has, or he may make a rough form-line sketch without any particular reference to these heights and put in his contours at his ease in his drawing-office. Where the topography is fairly simple, probably the

first course is the better; but where it is complicated it might take up too much time in the field and can be left till later.

It is sometimes advisable to take angles of elevation or depression to points not yet sufficiently fixed to enable him to work out the height. In these cases he writes the natural tangent down along the ray drawn to the object, to be used as soon as he gets a suitable intersection to that ray. He has now concluded his work at this station, and as a last operation he checks the orientation of the table. He then goes to the bridge, sets the table by the back ray to the station just quitted, and resects from any other fixed point to fix his position.

Enough has probably been said to show how, at each station, there is a certain routine to be followed; but the pleasure of plane-tabling lies in its variety, and it is not worth while to expand any further our imaginary case. With a suitable control or framework the plane-tabler can start at one end of his area and quarter the ground thoroughly as he goes. More frequently, however, his framework is deficient in some parts and he may have to break off his detail work and resect carefully to establish a new first-class point. In general he will find that keeping to the higher ground enables his work to go faster, but that for some of the detail, such as streams, he will have to occupy stations on the low ground.

Since he has drawn in all the detail as he sees it and has rubbed out the pencil rays as soon as he has finished with them, the sketch is fairly complete as it stands, but it is all in pencil. When he gets home he has to ink in his detail and tidy up the map generally. The inking in must, of course, follow the pencilling exactly, except where he has to interpolate contours guided by rough form-lines. In the course of inking in he will probably detect certain areas less satisfactory or less covered with detail than others, and will make a note that those portions of the area must be visited again the next day.

This brief description of detailed sketching on a plane table is probably not nearly as helpful as a half-hour in the field with an experienced plane-tableer. Nevertheless, the reader can assure himself that, provided he has got a clear idea of the theory, he can make himself a perfectly adequate plane-tableer merely by practice in the field. He will also find that this book has only given him an idea of a few of the dodges for work in the field, and that he will be constantly devising new ones for himself. The charm of plane-tableing lies in the fact that at almost every station a new set of minor problems arise.

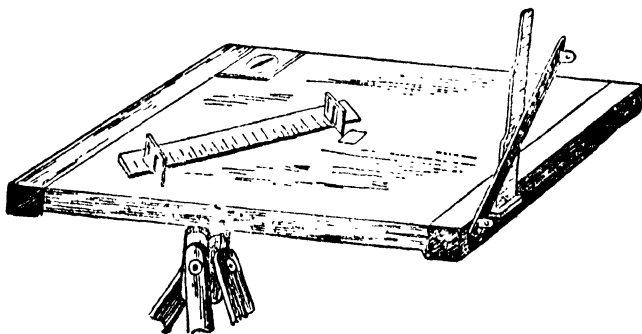

Plane Table, 1599

Chapter IX

FURTHER CONSIDERATIONS IN PLANE-TABLING

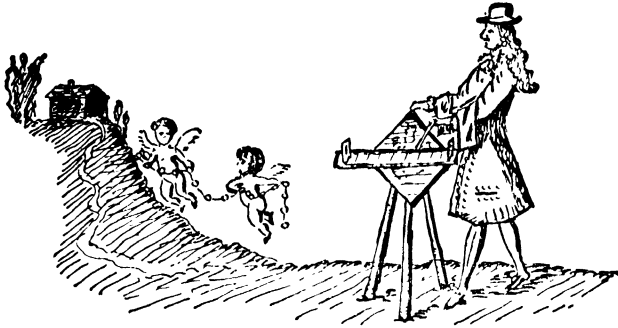

After Thomas Cleer, 1696

“ An instrument of such perfection, that no manner altitude, latitude, longitude, or profunditie can offer it selfe, howsoever it be situate, which you may not both readily and most exactly measure.”

DIGGES “ Pantometria ”, 1571.

IT was suggested in the last chapter that the plane table is the best of all surveying instruments for the ordinary work of the field scientist, whether it is used in new country or with the help of existing maps.

Such a statement might, perhaps, be qualified by adding that its success depends to a great extent on the ingenuity and experience of the user. It is indeed true to say that with no instrument can the careless worker get into a more glorious muddle if he neglects certain fundamental precautions.

The last chapter dealt with the ordinary operations in plane-tableing; the present one is designed to examine certain of these, and to suggest certain adaptations of them, for special purposes. It will be as well, also, to consider the sources of error to be expected.

The Paper

In many respects the most important part of the equipment is the paper on which the map is drawn. Not only does it have to endure much more exposure to the elements, and much more friction from the rubber, the rule and the worker's arms, than in any other form of plotting, but it is at all times the only record of all the work done upon it.

In professional work on small scales it may represent weeks of work by the surveyor, and it is for that reason that some survey services insure their plane table sheets on a sliding scale in proportion to the number of days' work represented by the maps on them. Although such considerations do not apply to the type of work for which this book is written, it is obvious that care over the paper to be used and its subsequent treatment is well worth while. It is recommended, for instance, that any important sheets should be traced as soon as completed as a precaution against loss or destruction of the original.

The qualities required in the paper are toughness, which to some extent involves thickness or "weight", as the paper

manufacturers describe it: resistance to rubbing, which rules out those which have an artificial gloss on them: and resistance to damp air, from which no paper is entirely free.

In a really dry climate there is nothing quite so satisfactory as Bristol board, even though its surface gloss soon disappears under the india-rubber, but in a moist atmosphere it tends to swell and buckle into a ridge. Hand-made drawing paper of medium to heavy weight is the best choice, since its quali-

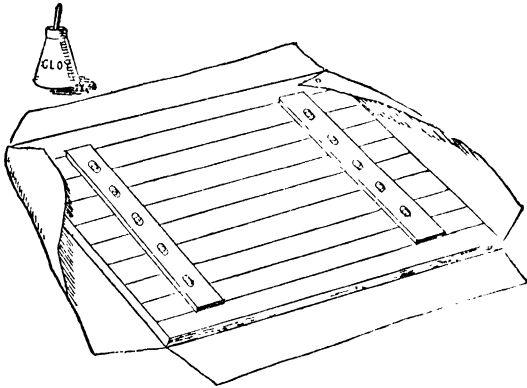

Fig. 63.—Mounting paper on the plane table

ties approximate to those outlined above, and though it expands when exposed to damp, it does so equally in all directions. Machine-rolled paper comes next on the list, and though it expands more in the direction of rolling than in other directions, this does not interfere with any but the more precise type of work. The smooth or hot-pressed surface is not durable in the field, and the slightly rough "Not" surface is easy to work on.

For important topographical work the disadvantage of paper expansion is overcome or at least diminished by mounting the paper permanently on a thin zinc or aluminium plate, which is then screwed to the plane table. Such a precaution is unnecessary for ordinary amateur work, but the way in

which the paper is fastened to the board makes a great deal of difference to its behaviour in the field.

For work which is going to occupy more than an hour or two it will save time in the end to make a semi-permanent mounting as follows.

The board is laid on the sheet of paper which is then cut out large enough to double over the edges, and the corners are cut out in the manner shown in the figure. The whole of the paper is then slightly damped with a wet cloth or sponge and the edges pasted on to the under side only of the board. As it dries the paper will draw thoroughly taut all over the board. When the map has been finished the paper is cut round the edge.

When the work is not likely to take very long in the field, it is sufficient to fasten the edges of the paper under the board with drawing-pins, but even then it is an advantage to put the paper on slightly damp. The drawing-pins should never be put on the top of the board, for they make holes in the board and interfere with the sliding of the sight rule. There are now several makes of sticky tape to be had which can be used on top of the table for temporary work, and this has the advantage of saving an appreciable amount of paper as it does not need to go round the edge of the board.

When the sheet has been mounted slightly damp, it will not become loose until it is again as damp as when wetted with the sponge, but it can be imagined that even the least drizzle or mist soon brings it to that stage. Work is impossible on paper in those conditions and the surveyor must cover it up with waterproof cloth to wait for better times. It will occasionally happen that mapping must go on in all weathers, and in that case one of the following plans may be tried.

Celluloid sheeting with a matt surface takes the pencil quite well, and if of good quality does not swell when wet as does cellophane. The roughness blunts the pencil rather quickly, however, and it is not easy to get rid of the pencil lines completely when "cleaning up". Zinc or aluminium

sheet is better still, except that the pencil is apt to disappear too easily. The ideal method for fine work is to use one of these two metals with a " scribe " of steel, such as a not too sharp needle in a pen handle. The rays are drawn very lightly and show up quite well in spite of being of silken thinness. The detail is drawn in rather more heavily so that the rays can be cleaned off with very fine emery cloth and yet leave the detail, which in fact fills up with the emery dust and shows up all the more clearly.

A point of some importance for work in summer is the strain on the eyes when continually looking down on the white paper. In tropical climates a khaki-coloured paper is sometimes used to diminish the glare, but for ordinary work a pair of slightly tinted glasses best serves the same purpose.

Sources of Error

The object of the plane-table is to make his map as accurate as the plottable error will permit, no less, but also no more. In fact, he is the most expert at the work who strives after the right degree of precision but no higher, and that degree is given by the scale of his map, a variable factor, and the fineness of his line, a constant one.

It will be useful therefore to mention some of the possible sources of error and consider how they may be kept within reasonable limits.

It is very easy to see how accurate any ray may be under a given set of circumstances, but general figures cannot be given with any satisfaction since accuracy in sighting and ruling a ray depends on such things as the length of the sight-rule, the thickness of the vertical wire, the definition of the object sighted at and the strength of the light. It must suffice to say that repeated rays to the same object from one station will not vary more than a few minutes of arc from as little as one up to perhaps 8. Taking 5 min. of arc or $\frac{1}{12}$ of a degree as a standard for comparison, it may be applied to various obvious sources of error.

Lack of parallelism between the edge of the rule and the sighting vanes is an apparent source of error, but a little reflection shows that it merely sets off every ray taken by the same amount, so that there is no actual error. It would not do, however, to change sight-rules half-way through a piece of work, for there must be some of this lack of parallelism in every sight-rule, and no two will be exactly the same.

Another point for unjust suspicion is occasioned if the two sides of the rule are not parallel, but since no plane-tabler should use any but the right side of his rule (unless he is left-handed) no error will occur owing to this cause.

It is quite different, however, if the vertical wire and the slit for the eye are not parallel. In such a case there will be a slight error in sights taken up or down hill, though little or none in level sights. Fortunately the effects would not be serious unless the two were visibly out of parallel, in which case they must be adjusted. The nature of the error can be seen from an example. If the bottom of one of the two vanes is $\frac{1}{30}$ in. out of parallel for a 15-in. rule, the parallax is 1 in 750, which is equivalent to about 4 min. of arc for the maximum error.

This is therefore not a serious source of error since by holding up an alidade at arm's length and looking through the sights, one should detect as much as $\frac{1}{30}$ in. set off of one vertical from the other.

The error if the whole sight-rule is tilted to one side may be more important, and, of course, this depends on the leveling of the table. If the sights are inclined there will be no error for a level sight, but one taken looking up or down will be affected.

Suppose that the tilt is one degree, an amount which might easily pass without notice. If the vanes are each 2 in. long, and the sight is taken from the top of one to the bottom of the other, the "set off" will be $2 \times \tan 1^\circ$ in., that is to say, about $\frac{1}{30}$ in. This amount of parallax or "set off" in a 15-in. rule would give a possible error in the ray drawn of over 6 minutes of arc.

With a tilt of as much as 4° , the error would begin to be intolerable. It will be found by experience that in reasonably open country a setting up of the table by eye can easily be kept within a couple of degrees of the level line, provided that the tabler steps back a little and views the table from two sides when he has set it up. The case is different on steep slopes when, by a curious psychological tendency, the table is nearly always set up leaning down hill. In rough country it may be advisable to have a small level or a circular bubble for testing the set up. On the other hand, with care even in such situations, the table can be set as nearly horizontal as the limits demand, especially if a round pencil is used and rolled over the paper in two directions at right angles to discover any noticeable tilt. If heights are being taken for the map, there will be an Indian clinometer or an Abney level in the equipment carried which can always be used to check the levelling.

It will be seen that none of these sources of error need be serious, and they are bound to be exceeded by accidental mistakes in sighting or ruling or setting which nothing but practice will diminish, and which can never be entirely eliminated. These are of the nature of personal errors, and need some attention. They may be divided into those which are derived from the features sighted, and those due to lack of care in the pencil work.

In plane-table work there is rarely time to set up special marks for stations, so the surveyor makes use of any natural or artificial objects which may be already on his area. These may be anything which he can see well enough to sight on, and may range from the vagueness of a tussock of grass or a bush to the clear-cut profile of a peak or a church spire. He must take what offers, but in doing so must beware of certain snares.

For instance, a tussock or a bush or even a tree is rarely isolated enough to make identification easy from another point, moreover its outline is usually different from different

points of view. This is a particular difficulty with trees at such a distance that the trunk itself is not properly visible. If the tree is asymmetrical, bent over in one direction by the wind perhaps, and the ray is taken to the middle of the leafage, there may well be a difference of some yards in the position of the middle when seen from two different directions.

Again, the gable ends of houses and barns often look tempting points from one direction, and are invisible from another, and the same applies to the corner of a building, which at one part of the day is easily distinguished by sunlight on one side of the house and vanishes altogether when the sun moves round or cloud comes over.

Many otherwise excellent points are apt to be dangerous because of their number, such as telegraph poles, chimneys, peaked fir trees, prominent boulders, tufts of heather, or even similar mountain tops. These must be used, but they must be distinguished if possible by some note on the ray marking them. In the case of telegraph poles, in particular, it is not sufficient to write, say, "Second pole from white house", for from another station it may appear as the first or the third.

In small scale work in mountainous country the chief difficulty lies in the changing profiles of hills as viewed from different angles, and since long distances are covered between stations in such work some means must be taken to ensure recognition. Two methods which have been found useful in such circumstances are as follows.

In the first place, a common difficulty with a range of distant hills is that they appear to be in a line, whereas they are only so in profile. If such an apparent row of peaks can be sorted out into those which are nearer and those which are farther away, the transposition of some of them when at a distant station is not only explained but quick identification is possible. When a first series of rays to such a range of mountains was taken, the mapping being on the scale of $\frac{1}{100000}$, there would often be no chance of getting good intersections to them for at least 10 or 15 miles, possibly several days

later. They were therefore temporarily located by using a substation, up to a mile distant, where another series of rays to the same peaks was drawn. The intersections would, of course, be very oblique and would not be taken seriously into account as two of a three-ray intersection, but they gave at once the relative placing of the peaks, and were of great assistance when a much more distant station was occupied.

The second method tried was to make a careful drawing of the peaks from the station where the rays were taken, either in a notebook or at the edge of the sheet. Though useful from a topographic and geological point of view, these profile sketches were not, in point of fact, so helpful in recognizing the individual peaks as the method outlined above. On the other hand, the names given to the different peaks were thereby recorded against an outline of each peak, which was of considerable help in elucidating the descriptions written along the rays.

This difficulty leads naturally to a consideration of the names to be written on the rays. They must, of course, be brief and descriptive, but in country which has many of the same kind of features this becomes a task of some magnitude. Whether it be peaks or pine trees, there is, after all, a limited number of adjectives which truly describe and invention soon lags behind the need for more designations.

This applies more to small scale mapping in hilly country where the points are many and distant. In large scale work, especially in inhabited lands, there is usually a much greater variety of features, and since most of the points only require names until they have been fixed by two or three rays, many are periodically rubbed out, and the field is left clear for the same set of adjectives to be applied to new points.

Coming now to accidental mistakes made in sighting and drawing rays, we may mention a few common ones to be guarded against. Mistaking the object sighted for another and similar one has already been referred to, and in such cases the mistake is often exposed when a third ray to the

object is drawn, and passes far from the first intersection. Objects which are ill-defined are also likely to cause mistakes, especially in a bad light, for the slit at the eye end of an open alidade lets through very little light so that an object which can only just be seen with two eyes can never be distinguished through the slit. This can usually be surmounted by noting something much more marked which is "on range", that is, in line with the dim object, and sighting to that.

Another but minor source of unsatisfactory "fixes" is neglecting to hold the pencil, when drawing the ray, at such an angle that the line emanates from the station of origin. The ray itself is never drawn the full length, but the pencil must first be pointed at the paper over the station and held at the same angle when drawing the ray farther along the rule. The error due to this neglect may not be serious, but it gives a series of very small triangle intersections instead of points.

Perhaps the most frequent kind of blunder is due to a slight shifting of the rule just before or during the ruling of the ray. It is advisable to acquire the habit of holding the sight-rule with one or two fingers of the left hand laid upon it while sighting, and to hold that same position until the ray has been drawn.

Telescopic Alidades

So far nothing has been said of a more refined type of plane-tabling, using a telescopic alidade instead of an open sight-rule, and not very much space can be given to it because owing to the expense of the equipment and its weight in the field it is not suited to the requirements of our readers.

In other countries, particularly in the United States, where plane-tabling is regarded as one of the major forms of surveying, and is used where we should often use a theodolite, the telescopic alidade is regarded as a *sine qua non*, and has been developed into a high-grade instrument with many accessories and adjustments. There is, in fact, no reason except expense why a lighter form of the equipment should

not be developed and used in England, but until a demand could be created the instruments would be costly.

The reasons for adopting the telescopic alidade in spite of the extra weight and clumsiness of the outfit are twofold, neither of which alone would be sufficient.

The first is that with a telescope the sights can not only be taken at a much greater distance, but are far more precise and easy to take, for the amount of light coming through the telescope is many times that coming through the slit of the open sight-rule.

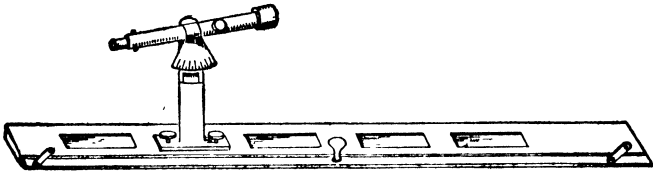

Fig. 64.—Telescopic Alidade

The second and major reason is that with a telescope it is very easy to develop a system of subtense measurement, by which a reading on a levelling staff can be made to give the distance of the staff to an accuracy comparable with chaining, up to a certain distance.

The American plane-tableer, therefore, besides having a very large table with heavy tripod, telescopic alidade, surveying umbrella, &c., takes with him into the field one or two or even more assistants, each with a levelling staff. These men hold their levelling staves wherever directed, and the plane-tableer sights them for direction, reads the subtense figures, computes the distance from tables or an attachment to the alidade, and marks in the position finally from the single sight.

Such surveying is beyond the scope of this book, yet with suitable modifications subtense measurement with a telescopic alidade can give excellent results with lighter equipment and deserves a brief description.

The telescope in such an alidade is similar to that of a theodolite, but its cross wire or "diaphragm" has a ruling such as fig. 65, and the two outside horizontal lines therefore "intercept" a certain length of the levelling staff in the field of view. This intercept is in direct proportion to the distance away of the staff. Moreover, it is not difficult for the instrument makers to draw the horizontal lines (often called "stadia" wires) so that this proportion is 1 to 100, in which case if the sight-line is level, the intercept in feet as read in the telescope is merely multiplied by 100 to give the distance in feet. With inclined sights a correction must be applied,

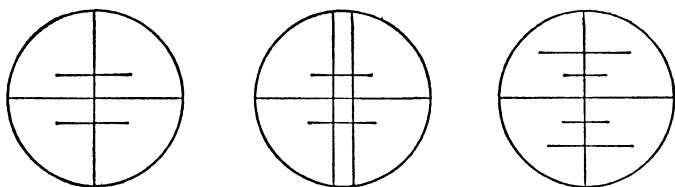

Fig. 65.—Various rulings for stadia lines on telescopic diaphragm

though this is hardly necessary unless the inclination is more than 5° , a slope of about 1 in 12.

Both the accuracy and the distance to which sights can be taken depend on the size and quality of the telescope, but one should be able to reckon on an accuracy of less than 1 per cent for sights up to 300 ft., and sights as distant as 700 ft. can be taken without gross errors.

It will be obvious from the above that although little is to be gained from the subtense method in exploratory work, it does lend itself very well to small area accurate work of the type that would be required for making a survey of an archaeological site or a small area of great geological detail. Without involving very much extra time in the field the heights of the points where the staff is held can also be obtained.

Nearly all engineers' levels in this country are now fitted with subtense wires, and any textbook gives a full explanation

of the theory and practice of "tacheometry", as it is called. It seems to the author that this rapid way of finding both direction and distance with a single sight is worthy of modification for the purposes of the field scientist.

Applications of the Plane Table

Such a multiplicity of warnings and prohibitions may well have caused the reader to regard plane-tabling with greater awe than it deserves, and the best way for him to treat the matter is that in which he treated his first instruction in driving a car. There are so many ways of doing the wrong thing that the learner is bound to be bewildered, until he remembers that other people of equal intelligence have come to no harm, and he develops a philosophic calm which gradually merges into confidence with experience.

The chapter may conclude with some examples of the value of plane-tabling to the field scientist in Great Britain, where he need rarely have to undertake the labour of constructing his own framework. It must be understood, however, that without the Ordnance Survey map as a framework, some of these operations would be more quickly done by some other method than plane-tabling.

The 25-in. Scale

It will be as well to consider the Ordnance Survey maps in order from the largest published, known as the 25-in. to the mile scale. Plane-tabling on this scale (1 : 2534) would be very easy in most respects, but it must be remembered that the plottable error is $\frac{25 \times 5280}{100} = 2$ ft., and if the purpose demands it measurements must be made with more care than usual.

Considerably less than a square mile of country would go on the table, therefore recognition of objects presents little difficulty. The kind of purpose such mapping might have in view might be the distribution of plant associations, the tracing of small drainage channels, the occurrence of some sporadic feature such as glacial erratics or birds' nests or rare

plants. In nearly all these cases it is the relative grouping rather than the actual position that is required, and a lower order of precision can be used which makes for speed.

The sequence of operations need not be described in detail, but the following procedure would suit most cases. The orientation would have to be found by setting up first at some point recognized both on the map and on the ground. This will most often be the corner of a field, or junction of property boundaries, and the table is set by laying the sight-rule on the map pointing to another recognizable feature, and then rotating the table till the sights are on the feature.

Taking some sporadic distribution of detail as an example, the usual way to go to work would be to draw in by eye all those individuals, say erratics, which are close to the station, even pacing to some of them if that degree of precision is required, and taking a quick sight to them for direction. Then, choosing some point next to be visited a temporary ray is drawn to it and a small mark left at the station. At the new station setting by the back ray gives the correct orientation, and a single intersection, or two for more careful work, from another recognizable point will fix the new position.

Such work will often be carried out on more or less featureless country, such as a marsh or a moor, and the number of points recognizable may be few. In such a case the surveyor will save time in the end if he either sets up visible marks at many of his stations or intersects prominent objects from such stations as he knows are first class, thus building up a minor framework of his own.

Under ordinary circumstances the work would be so simple that he would rarely be engrossed in the survey problem to the exclusion of his scientific inquiry.

The 6-in. Scale

The Ordnance Survey sheets on this scale ($\frac{1}{10560}$) are probably much more useful to the field scientist, for they cover

as much country as can be traversed by walking in a few hours, they show much of the detail to scale, such as houses and roads, they print the values of the bench marks, and show where the trig mark control was situated, though the actual marks are underground and may not be uncovered. Areas of 2 or 3 miles across can be dealt with on one plane table, and except in very wild or uncultivated country there is usually a sufficiency of points on the map recognizable in the field. Moreover, except in towns, there is usually sufficient room on the map for the fresh detail to be put in without being cramped and illegible.

There is no real difference in procedure from that on the larger scale.

The scale of 6 in. to the mile is in fact almost the ideal one for the kind of plane-table work which field scientists are likely to require. The plottable error is of the order of 3 yd., so that the worker can estimate distances up to 30 or 40 yd. without serious error. He can draw in detail to scale down to the size of small rivers or ponds, and his contours to show minor features will usually be prominent enough for his purpose. For these as well as for their own technical reasons this is especially the scale for the geologist and the student of land forms, both of whom are much concerned with the surface relief.

The map itself contains the figures for bench marks and spot heights which are his data for calculating fresh heights, and except in rather uninhabited parts of the country there will usually be enough of these to enable the contour survey to go ahead fairly quickly.

In the author's opinion the very best way of learning to be an apt plane-tableer is to take out a 6-in. map of reasonably hilly country and map in contours at 10- or 25-ft. intervals. It is more difficult than making a map of detail which can be seen, a variety of ways of finding one's position are available, and, in particular, the worker will acquire an "eye for country" in the very best way if he is continually drawing in contours

of minor features while he is looking at them in the field and relating his curves to the heights already on his sheet.

The 1-in. Scale

Plane-tabling on the scale of $\frac{1}{63360}$ is not really difficult, but it calls for considerable neatness of drawing, and for an appreciation of distance which is not easy after work on the larger scales.

It will not closely concern the readers of this book since the kind of detail in which they would be interested on that scale is usually already on the maps, but the contours are not really close enough on the printed maps for scientific use, and the mapping of extra contours will be the usual reason for using this scale with the plane table. Except in the more remote parts of the country the amount of lettering already on the map will prove an embarrassment. It must be remembered that houses and roads are not drawn to scale. In higher parts of the country, where additional contours are most likely to be required, there will be some trouble in finding exact points from which to resect, unless the hills are truly peaks or there are distant churches visible. Provided that a church is over 3 in. distant on the map, the centre of the black square representing its position will not give an appreciable error.

The main difficulty in mapping contours on the printed sheet is that there are no heights printed on it except the tops of special hills, and the spot heights along roads. For the positions and value of bench marks the 6-in. map has to be consulted. A study of any 1-in. sheet in rough country will show that both for this reason and because of the comparatively small scale it would be no use attempting to map contours at much less interval than 50 ft. This interval, however, may be very valuable in view of the fact that beyond 1000 ft. above sea-level the Ordnance Survey contours which have been surveyed, in contrast to those which have been interpolated in the drawing office, are 250 ft. apart, a vertical distance which may effectively hide a great deal of the relief

which is of prime interest to the student of land forms and geology.

The open sight alidade and the Indian clinometer begin to reach their limit of utility on this scale, for sights of as much as 2 miles will be often required for fixing position and 1 mile for finding height, and the difficulty of seeing clearly at that distance will introduce errors.

It will be found that mapping on this scale is for the experienced plane-tableer and not for the beginner.

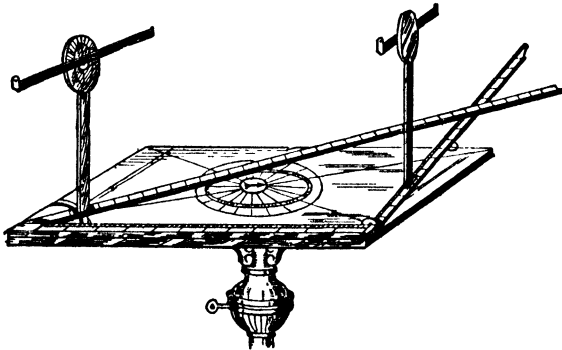

Foullon's Holometer, 1551

Chapter X

SURVEYING WITH THE HELP OF PHOTOGRAPHS

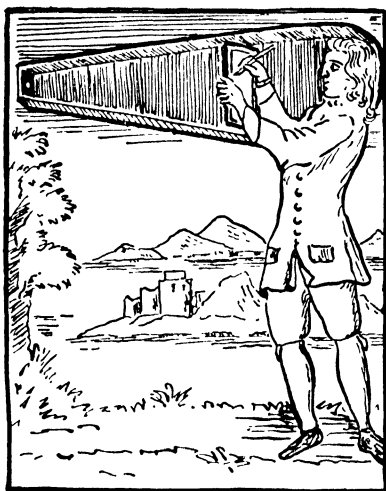

After Robert Hooke, 1694

“ . . . whereby any person . . . shall be able to give us the true draught of whatever he sees before him, . . . as while he can nimbly run over, with his pen, the boundaries or outlines of the prospect.”

ROBERT HOOKE, 1694.

THE amateur surveyor will occasionally come across a piece of work which cannot be done with much success by any of the methods so far outlined in this book, either because the detail he requires is inaccessible, such as on cliff coasts, steep ravines, &c., or because the time he can spare in the field is not enough for ordinary surveying processes.

Of these two cases the latter is by far the most frequent, and to geologists in particular the experience of having to abandon work in an interesting area for lack of time must be a common one. One might almost say that in any field science which has to do with distribution of certain things the worker usually feels he has not had enough time on the area to map it as he would like.

It is natural enough therefore to remind such workers that with a slightly increased equipment and some acquaintance with photography, he has the means of taking back with him perspectives of his area which are much more than mere pictures, that is to say, they can be measured from and used to amplify maps made by ordinary methods. It will be noticed that we have carefully refrained from heading this chapter "Photographic Surveying", which is a branch of survey quite beyond the scope of this book or, in general, of the readers to whom it is addressed.

Nevertheless there are times when a judicious photograph may make all the difference to the map, if certain requirements are fulfilled, and a few geometrical principles applied to it, in order to transfer its perspective detail to the horizontal plan of the map.

There is little space for the theory of photographic perspective, nor will readers have time or patience for special equipment, so we shall content ourselves with describing how photographs taken with ordinary cameras may, in a few special cases, be used for plotting some kind of a map.

The chief requirements are that the position of the camera station must be known, and that the camera should be held

truly level, that is to say, the film or plate must be vertical. Neither of these is hard to fulfil, yet is essential if the photograph is to be used for mapping.

The focal length of the lens must be known, but this is usually engraved on the front of any good lens. If it is not, there are simple ways of measuring the focal length to be found in any optical or photographic textbook.

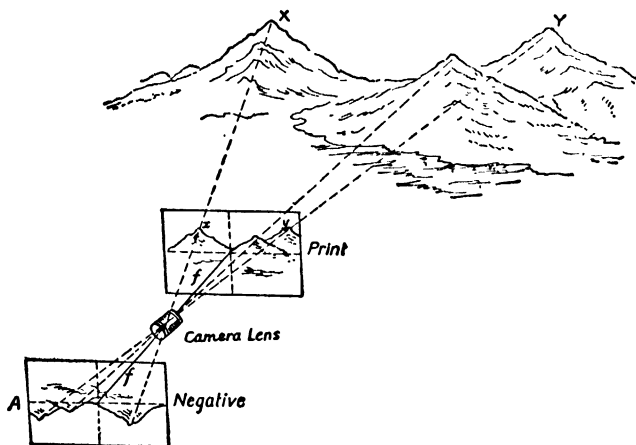

Fig. 66

The relation between the landscape and its image on the plate inside the camera is shown diagrammatically in fig. 66. Here the lens is all that is shown of the camera and the plate inside the camera (A) shows what is seen if a focusing screen is used, a view of the landscape upside down.

The distance f is the focal length of the camera, that is, the distance between the plate and the optical centre of the lens for distant focus.

When the print is made it can be regarded as being the landscape placed right way up at a distance f in front of the lens as though the camera had taken a drawing of the land-

scape at that distance, the rays of light from the various objects passing through their own images on the print, then through the lens and on to the plate.

To find the angle between hills X and Y in the view from the camera station, we should measure it with a theodolite or two compass bearings, and in doing so we should be using the same rays of light from those hills as the camera has used to affect its plate. Therefore the distance between those hills

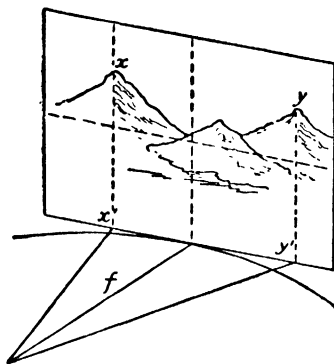

Fig. 67

on the print is a measure of their angular distance, and this can be found at once by a simple graphic construction.

If an arc of a circle is drawn of radius equal to f , the focal length, and the print is held vertical and tangent to it, we can drop perpendiculars from hills x and y to the tangent line, or picture trace as it is called. Then straight lines to x' and y' from the centre of the arc will give the true angular distance between those hills as seen from the camera station.

Let us now suppose that we know the horizon plane on the print, which would be a horizontal line half-way up the print if the camera were truly level, and that we wish to find the difference in height between the camera station and hill x .

From fig. 68, showing this item of detail only, it is clear

that the height of the hill, H , is to the distance the hill is away, D , in the same ratio as the length from x to the level line, xl , is to the focal length, f , or

$$\frac{\text{Height of hill}}{\text{Distance from camera to hill}} = \frac{H}{D} = \frac{xl}{f},$$

$$\text{or } H = \frac{D \times xl}{f}.$$

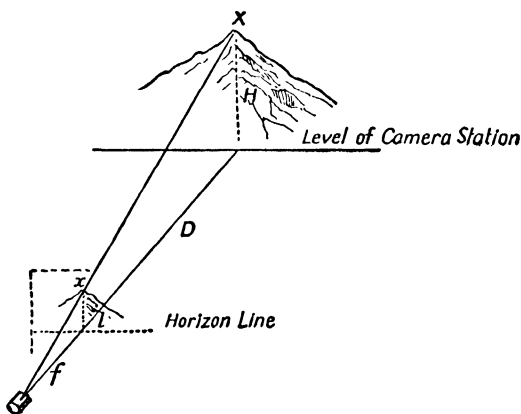

Fig. 68

Now it is possible to measure xl , though not very accurately in the case of a distant hill, so a rough measure of the height of the hill can be got from the photograph.

These few considerations about the perspective of a photograph are all that will be required for the purpose in hand.

The two methods which are recommended for the use of photographs in mapping may be called:

- (1) The method of intersections,
- (2) The method of perspective grids,

and they will serve for such general cases as those outlined at the beginning of the chapter. It must be left to the reader to apply the principles to such variations as he meets with.

The Method of Intersections

Let it be assumed that the surveyor is dealing with a piece of country which he cannot put on his map either because he cannot reach it or because he has not the time available. This may be the steep side of a ravine, or a mountain cirque, or something much smaller, such as a quarry face.

In this case two photographs only will serve the purpose of showing the method, though in practice it might be advisable to take more in order to cover the ground more thoroughly.

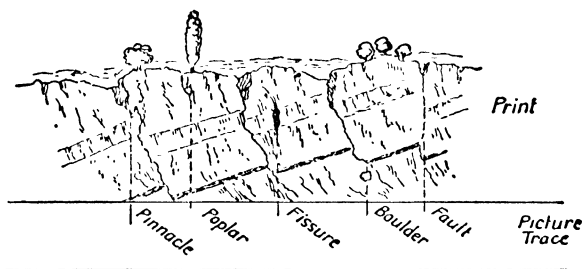

Fig. 69.—Picture trace being made from the photograph

The first essential is to know the position of each camera station. If these are not already on his map then a base must be measured between the stations. It is desirable to know in what direction, relative to the base, the camera was pointing at each end, but this is not essential if one camera station appears in the other photograph. Let us suppose that the plane-table when fixing the two camera stations took rays to one object which he knew would appear in the photographs, and so fixed its position.

When the prints are finished, he first of all selects the points on each which he wishes to plot and makes a picture trace of them on a slip of paper as shown in fig. 69, numbering or naming each of the little ticks representing the projected position of each point. He then draws his base line to the

scale required, or, if the camera stations are already on his plane-table map or traverse, he can plot directly on the map.

From each end of the base he describes the arc of a circle with radius equal to the focal length, and sets off the angle of the rays he took to a special object in the field, and draws that intersection. The picture traces are next fastened down to the sheet tangential to the arcs and touching at such a point that

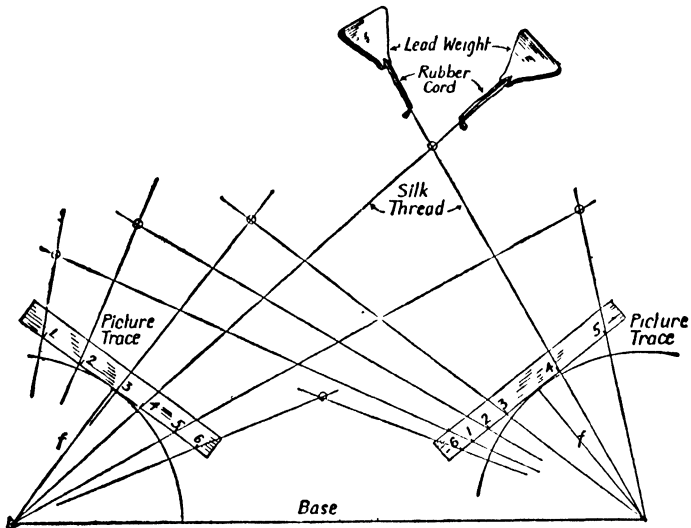

Fig. 70.—Plotting intersections from the picture traces

the rays to the common object in the two photographs pass through the corresponding ticks on the picture traces. The set out will then be as in fig. 70, and it may be quite appropriately compared to two plane-tables at each end of the base drawing rays to the same features.

Rays are now drawn through the corresponding marks on the picture traces and will give the positions of the different features. If many photographs are being used for plotting, it is worth while to employ thin thread for the intersections

to avoid the work of setting a straight edge to one mark after another. The two threads have little lead weights pinched on to the ends, and the other ends are fastened by a needle to the two camera stations. The threads are then moved along the picture traces acting as rays, which are kept taut by the weights or by indiarubber cord, and their intersections are pricked in as found.

As soon as the features are plotted on the map their distance from the camera station is known, and their respective heights above or below the camera station can be calculated.

It must be realized that without a level line drawn carefully across the plate, as can be done with a print from a proper phototheodolite, the datum is not exact itself, and only approximate heights can be found. To a geologist, however, anxious to find thickness of strata in an inaccessible cliff, the method has some value.

Enough has been said of the process to show that for small areas it is comparatively simple, and it can be modified to suit circumstances. It is desirable to use a camera not less than $\frac{1}{4}$ plate for clearness of definition, though there is nothing against using enlargements of smaller plates if the focal length for plotting is increased in the same proportion. The chief difficulty in the plotting is due to the different appearance of the same feature when viewed from a different angle, so that faulty recognition of common points in the two photographs gives rise to error or at least delay.

The similarity to the process of intersection in plane-tableing will be apparent, and the value of a third camera station to give three-ray intersection will be obvious.

Panoramas made up of several plates with a small overlap can be used equally well, and they remove the necessity of knowing the direction in which the camera was pointing if the two camera stations themselves appear in the photographs. But the intersections for points towards the other camera station will tend to be oblique and unsatisfactory. It is also

more difficult to recognize mutual features as they give very different aspects of those features.

It will be realized by the intelligent reader that just as resection in plane-tabling from three points will fix an unknown position, so the camera stations if unknown can be fixed, but with a moderate accuracy only, if three of the features already on the map appear on the photographs.

Since the picture trace touching the arc of radius f gives the angular separation of the three points as seen at the camera station, this can be copied off the picture trace diagram on to tracing paper, and the station plotted by the station pointer method outlined in the chapter on plane-tabling. This cannot be taken as a satisfactory alternative to measuring a base between the camera stations, but in small-scale mapping the stations will often be much too far apart to permit of base measurement, and may be points isolated from the general mapping of which the photographic operation is only a part. In concluding the note on the Intersection Method it may be reaffirmed that it can be of very definite use as an accessory to plane-tabling when that is undertaken either in very hilly country or has to be concluded before the worker has had time to cover all the ground.

The Use of Aerial Photographs

Photographs taken from the air are now so common that they are within the reach of most of the people to whom this book is addressed. Their use for actual survey work is a highly professional business far beyond our scope, yet we should be able to use the odd aerial photograph which comes our way.

It is best to consider that any photograph from the air is really a map, distorted in some degree unless it has been taken absolutely vertically over a level plain, in which case it is perfectly accurate, and of course it shows everything, in almost embarrassing detail, that there is on the ground.

That fullness of detail is in fact both the delight and the despair of anyone making a map from a vertical aerial photo-

graph. There is indeed everything on the photograph that he wants together with everything he does not want. His first business, therefore, is what is known as interpretation, the recognition of objects for what they are. There are two aids to becoming practised at interpretation. The simplest and most practical way is to walk over the area with the print in your hand, identifying the objects you see with the myriad shapes and shades they take in the photograph. It is not always possible to go over the ground, and the second aid may then be of enormous benefit, that is, the use of what is known as a stereo viewer. Most aerial photographs are taken in continuous strips and they have an overlap of some 60 per cent so that every object appears on two separate photographs, as viewed from two different positions of the aeroplane. When the pair of photographs is put under a stereo viewer and adjusted, the whole view springs into relief, usually an exaggerated relief. Dark dots which were meaningless before show themselves as deep pits or tall trees, or more often the shadows of them, and belts of deeper tone become ridges or valleys in an instant. By this means one has the illusion of looking at a relief model and interpretation becomes possible.

The next thing is to find the scale of the photograph. If it were taken by a survey camera it will have marked on it the height at which it was taken and the focal length of the lens. This gives the scale approximately, for we can imagine the lens of the camera as the apex of two triangles, one of them formed by the lines of sight to two objects on the ground and the other a miniature one of the same lines of sight inside the camera to the images of the same two objects on the plate or film. It is therefore a case of simple proportion. Thus, if the height above the ground were 15,000 feet and the focal length of the lens were 6 inches, the proportion is as 1 to 30,000, roughly 2 inches to the mile.

If those data are not on the photograph itself, then one must recognize two objects on it whose distance apart is known, either from a map or by direct measurement on the

ground. Even so the scale will be the same all over the photograph only when the view happens to be perfectly vertical and when the ground is absolutely flat. If the camera were slightly tilted the scale will be greater at one end of the photograph than at the other; and the same thing happens if the ground is hilly: the scale on the hills, that is nearer the camera, will be greater than in the valleys. If the photographs were taken by a survey plane, then we can usually accept the inaccuracy of scale from tilt as negligible for our purpose. If they were chance snaps taken on an ordinary flight, we should have to take special measures too long to describe here.

Of course the greatest value of such photographs for mapping is where the ground itself is inaccessible or when the detail required for the map would take a very long time to map on the ground.

A good example of such use is the mapping of a maze of water-courses in a marsh or swamp, or tidal salting. The first thing is to make a temporary "mosaic", as it is called, of the photographs, by fitting them together with plastic tape. Having cut one edge of each sheet straight, it is laid on the next one so that marks on one sheet fit exactly at the edge with the similar marks on the next. Then a tracing of the detail required is made on transparent material laid over the mosaic. A certain amount of "fudging" will be required, that is, making roads or rivers fit where they do not coincide exactly, but even so the result will be better than any ground survey in such difficult country.

The value of aerial photographs in showing up old boundaries, ancient earthworks, etc., is now well known and the mapping of them is done in the same way, by tracing.

A rapidly increasing area of the world is now being photographed from the air by pilots in machines especially prepared for such work, but the value of these photographs is being tardily recognized by laymen. Maps, of greater or lesser accuracy, are gradually being made from them, but the photographs themselves are far more useful in some respects than

the map, especially when they are paired under a stereo viewer. This is especially true in countries where there are few maps in any case and great stretches of country almost unvisited by man, yet easily flown over by a plane.

Prints are expensive and a good stereo viewer even more so, yet under certain circumstances the cost would be saved in a year or two in giving information which otherwise would require many journeys over the ground itself.

In settled countries like England, which are well mapped and much photographed, the use of aerial photographs will usually be to find the distribution of something not entered on the map. It may be as simple as the distribution of new houses since the map was made or as difficult as plotting types of trees or special crops or flood areas, in fact of anything large enough to appear on the photographs. The changes in sand-banks or shore lines are a good instance of something which cannot be surveyed quickly but which are recorded for a certain date and hour automatically by the camera.

It is certain that the amateur mapper has not yet realized how valuable is this new method of adding detail to his maps, if he can acquire or borrow the photographs. Even the farmer, by practised study of aerial views, can see something on them that he is liable to miss on the ground. A time will come when the simple mirror form of stereo viewer will cost only a few shillings and when the takers of such air photographs will find a wide market for their prints. In the meantime here is a diagram of that form of stereo viewer for which only a slight

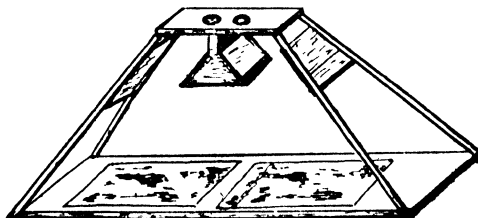
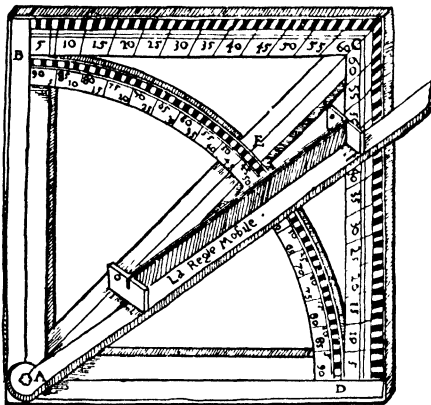

Fig. 71.—Stereo Viewer

amount of carpentry and two large and two small mirrors are required.

Photographic methods are better adapted to surveying of the exploratory type than for homeland use, but few explorers realize that more trouble taken over their photographs would make these of real assistance when their maps are compiled.



Geometrical Square. 1629

Chapter XI

INSTRUMENTS

NO book on surveying for amateurs can be considered complete without some hints about instruments, as the beginner is liable either to spend money needlessly, or to take fright at the initial cost of an equipment and decide that surveying must await better times.

It should be clear from what has gone before that a great deal of useful mapping can be done with little more than a prismatic compass and a clinometer, but if these are good ones they will cost up to £5. If the type of work to be done merits the use of a plane table, then the expense will be trebled if a complete equipment is purchased.

To a professional surveyor whose instruments are in constant use and represent a source of income, the prices of good hand instruments are not prohibitive, but to the amateur, who must regard his surveying as only an accessory to his other field-work, the cost may seem very high or, worse still, may persuade him to use poor types of equipment, which will seriously limit his work.

So, risking the scorn of professionals and the disgust of instrument makers, the author proposes to give suggestions as to the use of second-hand instruments and certain home-made adaptations. A certain number of compromises and makeshifts are possible, which could never be tolerated in official surveys, but are quite permissible in work of the type indicated in previous chapters.

Before leaving the subject of expense it will be as well to remind readers that the comparatively high prices of small instruments are not entirely the fault of the maker. There are possibly too many instrument makers in this country, and too many different patterns of the same type of instrument, but the manufacturers cannot organize anything in the nature of mass production unless and until there is a large and steady body of amateurs creating a demand.

There are many wireless components now which are just as much instruments of precision as a prismatic compass,

and which are less than a quarter the price of the compass, but that is entirely because, with a large demand, makers have been able to install special machines to turn out accurate parts in quantity and so reduce the price.

This cannot happen to any marked extent with survey instruments, but while the manufacturers can encourage the market by sound design and by making large numbers, they must in the end depend also on an increased demand by amateurs.

The instruments mentioned in this book will now be considered in the sequence in which they occur, with a preliminary note on some of those accessories, which hardly come under the heading of survey instruments, yet are essential to the work.

Plotting Instruments

The greater part of the map work described herein can be done with cheap instruments: the only two items which must be really good are the ruler or straight edge, and the protractor.

For plotting in the field the boxwood protractor of "Service" pattern serves both purposes well. Being designed for military use, it has certain scales inscribed on it which are of little use for our purpose, but it is well made and durable. The smaller and cheaper protractors are bad bargains in the end, though a cheap celluloid type after the Service pattern will serve for a time until it gets warped by wet or usage. The boxwood pattern will cost about 5s. The geographer's protractor mentioned on page 23 is probably the most useful of all, but is no longer available.

If much plotting is likely to be done indoors, a semi-circular protractor of celluloid, or better still, of thick metal, is a convenience as giving a greater radius for the degree marks than the 6 in. by 2 in. protractor. Celluloid set squares come under the same category, and as both of these are articles of regular school equipment they can be had in all sizes and prices.

The ordinary good boxwood ruler marked in inches and tenths with a thin bevelled edge can be made to serve for most of the plotting, but it must be tested occasionally for slight warp. For more frequent work a steel straight edge is a great advantage, and they are moderately cheap up to 12 in. or so in length. They are apt to get rusty, and to smear the paper with dirt, so besides keeping it in a dry place and giving it an occasional rub with emery cloth on the flat surface, not on the ruling edge, it is advisable to fasten a thin piece of baize or heavy cloth to its under side. If this is done carefully and not quite to the bevelled edge, it lifts the edge a fraction of an inch off the paper and allows a line to be ruled with a ruling pen without causing the common accident of ink running under the ruler.

The expensive sets of drawing instruments said to be beloved of the engineering student are of no use to the map-maker, any ordinary pair of dividers being satisfactory for transferring short distances, and a school pattern of pencil compass will do for the small amount of arc-striking that is required.

For extensive plotting of traverses by co-ordinates, that is to say, over large sheets of paper, a beam compass or "trammels" might be required, and of these also there are school types which are quite good enough. For occasional use it is quite easy to make one by inserting a needle into the thin edge of a lath and contriving a pencil clamp to move up and down the lath.

A drawing board is another convenience which is by no means essential, and there is no need for the rather expensive article sold for mechanical draughtsmen which is accurately fashioned for use with tee-squares. To the map plotter a drawing board is merely a portable support for his map which can be tilted, and the amateur carpenter can soon contrive one for himself if he cannot find a pastry-rolling board free for his purpose.

The sketching board is little more than a drawing board

taken into the field, but it should be light, and a thick plywood is very suitable. For size anything between 15" × 12" and 20" × 15" will be found convenient. It is advisable to have protection from rain available, and this is always at hand if it has a cover of American cloth which folds over the front and fastens with two press-buttons or other similar device. A convenient arrangement is shown in fig. 22.

For finishing off the map, lettering, colouring, &c., there is no end to the articles which might be bought. It must suffice to say here that although important lettering needs parallel pencil lines as a guide, there is no need to buy a parallel ruler, and that colour washes can be laid on well enough with camel hair instead of with sable brushes. It is as well, however, to use good colours: the cheap school set of colours will be trying to the temper even if it does not leave specks of pigment-grit where only smooth colour should appear.

The same considerations apply to such things as stencil sets for lettering: they are a luxury though they do undoubtedly improve the appearance of the finished map.

Field Equipment

Under this heading come such things as setting-out pegs, range poles, plumb-bobs, &c., which for the professional often form the bulkiest part of his equipment, and which the amateur, especially if working alone, must either do without or improvise substitutes for.

In certain types of work, such as making a detailed map of an archæological feature, it is worth while setting up pegs to mark corners, junctions, &c., which could not be distinguished otherwise from a short distance. Unless the area is a large one it will be found that the small lath pegs about 6 in. long, used by gardeners for labelling plants, do admirably for the purpose. If the tops are dipped in a bucket of whitewash they can be seen easily at 100 yd. distance, and two can be placed with faces at right angles for extra visibility.

For traverses and other work where stations are marked by

professional surveyors with painted range poles, the private worker has to make as much use as possible of those natural objects which are already on the line he wishes to measure. This will not only save a first visit to the station to set up a mark, but reduces the equipment to be carried. Any natural object on the line will serve just as well for sighting and alignment as one at the actual station, and the surveyor can

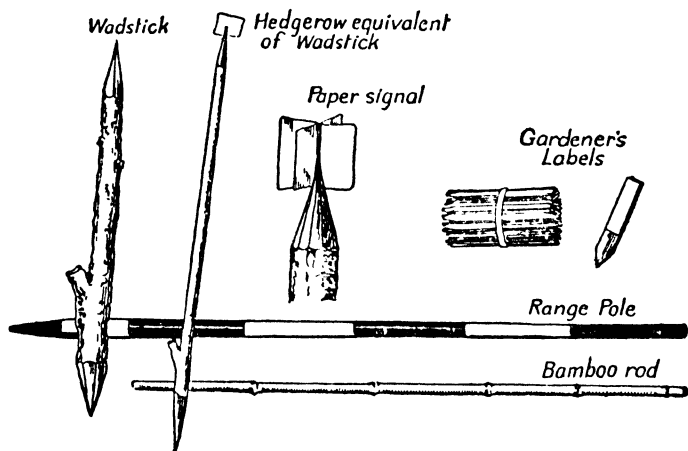

Fig. 72

set up his own mark when he reaches the station. Quite often, however, some fairly prominent mark must be left at key points, and although these must generally depend on the ingenuity of the worker in adapting whatever there is available, a few suggestions may be useful.

In countries such as Canada and Australia where timber is abundant and axes an ordinary implement of any party in the field, this marking is done by using what is known as a "wadstick" in Australia, obviously a corruption of "white stick". A young sapling or branch is cut a foot or so on either side of a fork, which is shaped as shown in the figure to make a

step for driving it into the ground with the axe. The lower end is pointed with the axe for entering the ground and the top is shaped, also with the axe, into a long fine point. The wadstick is driven at a slant into the ground, so that if necessary the pointed top can be placed accurately over the station by using a plumb bob. For short distances the whitish pointed stick is visible by itself; for longer distances the top is split and a small square of paper from the surveyor's notebook inserted like a wedge. A very effective modification of this mark can be used in this country for private work, a pocket knife taking the place of the axe and a rod cut from a hedge the place of the wadstick. The square of paper at the top being broad and very white can, of course, be seen to a much greater distance than any range-pole.

The professional range pole, painted in feet in different colours, is very useful for measuring offsets. It can be home-made, and there is no particular advantage in having it round, though a broom handle suggests itself for the purpose. Usually it is made 6 ft. long, and shod with iron. For the amateur it is suggested that it be 5 ft. long, and serve as an instrument staff as well as an offset rod.

The prismatic compass and the clinometer, though they are called hand instruments, are really rather difficult to read when held in the hand unsupported and a light staff of the height of the eye makes a steady and portable rest. A bamboo, as sold for garden stakes, is very suitable, and if it is painted in feet, with an end foot marked to tenths, it will serve for offset measurements as well as instrument support.

Chains and Tapes

As pointed out in an earlier chapter a chain is not really necessary for many of the operations, and careful pacing will often take its place for the measurement of distance. It should not be regarded as a necessity unless accurate work is being undertaken. It is really more important to be able to standardize the chain frequently, that is, to compare its

length with a standard, than to spend extra money on getting an expensive one. For this reason second-hand chains are satisfactory, which can be bought from 10s. upwards, provided a steel tape, rolling up in a spring case, is bought at the same time and never used except to standardize the linked chain.

There are various grades of chains, such as iron wire chains, steel rod chains, chains with links merely bent, chains with links brazed at the join and others. They are also of different weights. Steel is stronger, and therefore can be lighter, a consideration if 100-ft. lengths are used. For many purposes, a 50-ft. length can be made to serve. The cost of surveying chains would be from 20s. for 50-ft. chains and 30s. for 100-ft. new. Chain arrows run from 4s. per set.

Steel bands are more expensive and far more accurate, but they are not only less suited to rough work but are not really necessary for the type of work we are considering. They may be required, however, and of course are a better standard for the linked chain than the small steel tape mentioned above. If bought, it is worth while to keep it in paraffin in the possibly long intervals between use. A flat tin biscuit box, well soldered, does very well for this purpose. A 100-ft. steel band will cost from 35s.

A steel band can be graduated either by studs or by etching to parts of a foot, preferably tenths, so that close measurements can be made. This is sometimes necessary in an archæologist's work, and for that reason it may be preferred to the linked chain, in which the smallest unit is a link, whether 7.92 in. or 12 in. long.

For offsets too long to be conveniently measured with the rod, and especially if detail has to be "cut in" by subsidiary triangles from the chain-line, a linen tape is very useful. These stretch somewhat with use and are easily ruined by use in wet grass, but the type which has a few strands of brass wire threaded with the tape will do good service for a considerable time.

The Compass

The commonest type of prismatic compass is the Service pattern, which has not varied very much in the last thirty years. They are made in large numbers, and therefore are not so expensive as some other types, and there are always a certain number of them on the second-hand market, at prices from 30s.

In buying a second-hand article it is important to see that nothing is definitely misplaced or missing, but what is usually taken as a fatal ailment, sluggishness of the needle, is most easily remedied, and sometimes it is possible to purchase one in a street market for a few shillings which can be made almost as good as new in a few minutes. The compass needle and card is in fact the simplest part of a prismatic, and sluggishness can only be due to two things, a blunt pin support or loss of magnetism, both of which are easily remedied.

The glass cover of the military pattern can easily be prized off with a thin screwdriver inserted near the prism, and the compass card can then be taken out. If the pin is blunt it can be sharpened with emery cloth without taking it out, but if necessary it can be removed by loosening one small screw.

The compass itself consists of a comparatively rough looking piece of steel under the card. To re-magnetize it, it should be laid flat and stroked outwards from the centre a dozen times or so with two bar magnets, the north-seeking end of the large magnet being placed to the south-seeking end of the compass needle and vice versa.

Methods for attending to other frequent deficiencies in a used compass will suggest themselves to an ingenious buyer. Remedies for looseness of the hinge, fracture of the upper glass, slackness in the slide of the prism or faulty adjustment of the lifting lever, are all within the capacity of a steady hand.

The military pattern is, however, not ideal for survey use, and its luminous patches, its revolving glass top and its engraved exterior for night marching are all useless to the map

maker, something he pays for but does not use. These do not interfere with its value for taking bearings, and the chief reason why it is not a perfect survey compass is its small size, for the larger the compass card the greater will be the distance between the prism and the sighting vane, and the less will be the effect of imperfect centring of the card and needle.

Consequently, "civilian" prismatic compasses are usually made of nearly twice the diameter and differ in a few other respects. A useful arrangement in most of them is that the closing down of the vane when putting the instrument into its case automatically lifts the needle off its pin, whereas in the service pattern this is often done by the movement of a lever at the side which can easily be forgotten.

Some have an arrangement of a sliding mirror on the vane and dark glasses which can be slipped in front of the prism. These are for the purpose of taking a compass bearing of the sun for azimuth and are of no value in ordinary mapping. Most of them have an internal screw underneath the box for attachment to a tripod, which, however, must have no magnetic metal on it and must also have a ball and socket joint to allow the compass to be turned and clamped. These all add to the ease and accuracy of taking bearings in a traverse. For occasional work a camera tripod with brass fittings and a home-made pivoting arrangement can be just as satisfactory if rather slower in operation.

There is a type of combined prismatic compass and clinometer on the market which is a useful instrument, though expensive. The clinometer is released by a lever and swings above the compass card, when the instrument is held sideways. It is a pendulum clinometer, however, and suffers from the lack of sensitivity characteristic of all such.

Compasses for mine surveying are usually larger still, and of a prohibitive weight and price for use above ground.

The liquid-filled prismatic compass, of which there are several types, is a great boon if bearings are to be taken in the hand or on horseback, since they are "dead-beat", that

is, the compass moves directly on to its bearing without any prolonged swinging to and fro across the line of sight. They occasionally give trouble through evaporation of some of the liquid forming a bubble, for which a different remedy exists for each pattern of instrument and instructions here are useless. The best patterns have a trap into which the bubble can be coaxed by appropriate tilting. They are naturally rather expensive and are not likely to be used by many of the readers of this book. Their chief value is for taking courses for marching, when a long period of swing would be a great nuisance, rather than for survey work.

In testing any of these types it is best to take a number of bearings with it in the field, since that will test the optical parts of the instrument as well, but if that is not possible it can be tried for sensitivity quite simply on a shop counter. The card should be set swinging over nearly 180° by approaching a knife or piece of iron to it and the time it takes to settle is noted. If this is less than 10 sec., the instrument is faulty either the pin is blunt or the needle demagnetized, or there may merely be dirt on the "jewel". A good average compass will swing for 30 sec., but with a clean sharp pin and freshly magnetized it may swing for as long as 1 min. There is not much advantage in such extreme sensitivity in an instrument which is to be used in the hand.

Another way of testing its sensitivity and pivoting is to let it settle and then approach it with something feebly magnetic, such as a pen nib or a fine needle, which should cause it to move slightly, and it should return to its former reading when the exciting cause is slowly removed.

In the larger types of compass the vane may be either a thin bar of metal or a wire, horse-hair or other flexible line. Opinions vary as to which is preferable, but in the writer's view the flexible thread is the better since the metal bar has to be rather thick, and once damaged it is difficult to replace or straighten. The wire or thread can be varied in thickness and is quickly replaced and fixed by set screws or by plugging

the holes at each end with a sharpened match stick. Hair is not the best material since it relaxes with damp; fine wire is better, but it is more easily broken.

The trough compass as specially made for plane-tableing is an excellent but expensive instrument. As explained above, its purpose is not to set the table absolutely to its former orientation, but to get it within a degree or two of that setting so as to give a small triangle of error for the resection. Therefore there is no real need for the rather heavy and sensitive trough compass of the expensive type.

The prismatic compass itself is a good substitute, and in the military pattern in particular the hinged lid and handle can be laid out flat on the table, when the "nicks" on each end give the north-south lines when the zero of the card is pointing along that line.

Clinometers

As mentioned in Chapter VII, there are two types of clinometer, those relying on a swinging weight and those using a spirit bubble, and a general comparison of their sensitivity has already been made, in favour of the bubble instruments.

Unfortunately, these are the more expensive of the two, largely because they read to parts of a degree and require a vernier for reading the arc.

The plumb-bob type is represented by the Watkin clinometer, already described in a general way. This instrument, when carefully used, can be relied upon to at least half a degree, and its readings are easily taken as its reflecting mirror is made to magnify. It is often to be had second-hand as, with reasonable use, it is not likely to get broken, and is definitely of pocket size. The construction and working of the instrument are very easily understood when the lid is removed, and repairs of a minor kind are easily made.

When not in use the pendulum is prevented from swinging and has to be brought into action by depressing a button lever on the upper part of the instrument. This lever and

its locking mechanism occasionally gets out of adjustment through dirt or chemical rust, but there is no difficulty in cleaning it. The method of adjusting the centre of gravity by moving small screws in the weight is clear enough when seen, but these screws are liable to get loose if their position is often altered. They can be made to fit tightly by inserting a cotton thread in the screw hole.

As with nearly all hand instruments, the clinometer is not at all easy to use for an observation, unless it is steadied by resting on a 5-ft. staff.

There are one or two other kinds of pendulum clinometer to be had, the only one worth mention being that which is often found combined with a prismatic compass. The card attached to the clinometer is above that of the compass, as seen when flat on a table, and is kept from covering up the compass card under the prism by a lever operated by pushing in a rod. When it is to be used as a clinometer the rod is pulled out, setting free the pendulum. The instrument is then held vertically, and the sight taken with prism and vane; the clino-card swings under the prism and is read in the usual way. This card is nearer to the prism than the compass card, so it is necessary to push the prism farther away in its slide in order to get the graduations in focus.

It is not so easy to make adjustments to the pendulum in this instrument as with the Watkin type, and it is usually better to determine the index error frequently, and apply the necessary correction, than to attempt to get rid of the error by constantly altering the centre of gravity.

There is a form of pendulum clinometer often known as a road-tracer or road-grader which can be imitated cheaply. It is meant for setting out level lines or lines with a small gradient and can therefore be used as a level.

It consists of a sighting tube fastened to a stiff triangle of metal, which hangs from a smooth pin so that the whole instrument is a form of pendulum. It is usual to use the instrument hanging from its pin at the top of a staff about 6 feet

long so that the sighting tube is at eye height. On the sighting tube there is a sliding weight which can be clamped at any point. This weight alters the centre of gravity and therefore tilts the tube to any small gradient either up or down, and the degree of slope can be marked on the tube.

In its simplest home-made form it consists of a metal triangle, with sides about 10 inches long, drilled at the apex to fit a smooth pin projecting from the top of the staff. Screwed

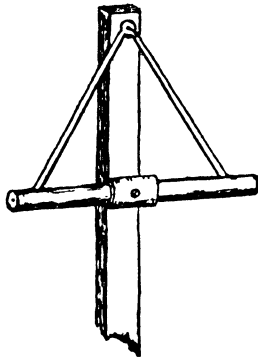

Fig 73.—Pendulum Clinometer or Road Tracer

to the lower arm of the triangle is a tube of metal, of brass or iron (gas pipe or water pipe), which is the sighting tube. One end is closed and drilled with a peep sight while the other end has a wire or thread horizontally across it. The tube may be a little longer than the arm of the triangle and it has on it a sliding sleeve of some weight with a thumbscrew through it to be used as a clamp.

The correct position for the sliding weight to give a level line of sight and small gradients is found by testing it with a surveyor's level or at worst alongside a building whose brickwork is known to be level.

The diagram gives an idea of the instrument; it can be used for levelling, for setting out drains or slopes of any kind, and should commend itself to farmers in particular.

The Abney Level

This instrument is sometimes called a reflecting clinometer, and is probably the most useful type for the kind of work described in this book.

There are slight variations in design, the chief being that while the cheaper instruments have a small wheel turning the spirit bubble directly, the better ones do this by a slow-motion tangent screw which enables the user to move the bubble very slightly without shaking it.

The direct-acting instrument is liable to become either too tight in its bearing and move by jerks, or too loose, in which case the bubble may move as it is lowered to take the reading.

The method of reflecting the image of the bubble to the eye is usually by a mirror at an angle of 45° to the line of the tube, and a thin line is drawn across the mirror which bisects the bubble image for a reading. The mirror is part of a sleeve tube slipping inside the main tube, and the sleeve also holds the single cross wire which is aligned on the object of which the vertical angle is required. The mirror easily becomes dusty as it has an open hole above it, but it must not be dusted with anything that might contain particles of grit as the silvered metal surface scratches rather easily.

The cross wire is well protected from injury by being well inside the sleeve; on the other hand, this renders it rather inaccessible when it needs repair.

The telescoping tubes of the eye-piece usually become a little slack with use. If this slackness is pronounced, it introduces an index error, which can be ascertained in the way already described in Chapter VII.

The adjustment of an Abney level to get rid of index error is done by using the screws at the end of the spirit level to alter its inclinations with respect to its metal holder. Frequent use of these screws is liable to strip them or loosen them, and it is better to apply the correction ascertained by test than to strive to make the instrument read absolutely correctly.

The Indian Clinometer

This is not truly a hand instrument, as it can only be used on the plane table, but it is the best of the clinometers, and it is unfortunate that it is rather expensive, though it may be bought second-hand.

It achieves its accuracy largely by reason of its length, from 8 to 10 in., which permits the use of a longer and more sensitive bubble than the Abney level has, and allows of an open scale of degrees which can be read to 10 min. of arc. It is sturdily made and rather heavy, so it will stand a good deal of wear. The fault which usually develops first is slackness in the hinges and in the levelling screw, and this can be remedied without much trouble. When the instrument has a cursor which racks up and down the forward vane it very often gets loose, and its cross wire becomes bent, but the cursor is not a vital part, as sights can be taken nearly as well without it.

Devised and developed in India, where the plane table has done so much of the topographic detail, the Indian clinometer has a high reputation. Nevertheless, it has its disadvantages, and it is somewhat surprising that nothing better has been produced. It is decidedly heavy as compared to the other articles of plane-table equipment and can only be used for vertical angles.

A telescopic alidade would not be much heavier and this would take both vertical and horizontal sights, besides giving a clearer view of the object sighted.

Its simplicity of construction is a great advantage, and unless it is dropped on hard ground it rarely goes wrong.

The Plane Table and Tripod

There are several patterns of plane table to be had, and beyond expressing an opinion in favour of the Service pattern with a full-length tripod, there is little to be said about the different types. Many are far too heavy and elaborate for

the purpose of amateur work, and makers have tended to regard the American patterns as examples to be followed, forgetting that the application of the plane table is very different here from the usual practice in the States, or on the Continent.

Thus it is not uncommon to see amongst the accessories advertised a special kind of plumb-bob, and a spirit level, not to mention elaborate methods of clamping the paper to the board, and ball-and-socket joints to simplify the levelling, all of which tend to increase the weight and complexity of the equipment.

It is far better to be content with a fairly cheap but sturdy table and tripod, which do not require the special abilities of the instrument maker, and to spend more money on the alidade and clinometer, which cannot be improvised. It may be useful to give suggestions as to how far ordinary articles may be made to serve the purpose.

For the table itself, an ordinary drawing board, or even a pastry rolling board, will do quite well. If it is thin or light it will need bracing on the under side with strips of wood or non-magnetic metal, preferably the latter in T-section, which can easily be put on. If it is of seasoned wood it hardly needs this reinforcement to prevent warping. In the centre of the board a brass bush, internally screwed for the clamping nut, is firmly fixed.

The tripod can be a stout camera type and may be expensive as compared with the table. The folding leg type can be used if ease of packing is likely to be a consideration; but the extra joints involved tend towards insecurity besides adding to the cost. Most camera tripod heads consist of a small round metal disc with a central screw, and the best way to deal with such a pattern is to screw a circular piece of board, about 6 in. in diameter, over the metal disc, and to replace the camera screw, which is too small, with a much stouter one, up to $\frac{1}{2}$ in. in diameter, with a wing nut for screwing it up. The wooden tripod head is then covered with stout baize

or thin felt over which the table will turn easily yet which will permit firm clamping.

As mentioned in Chapter VIII, the critical part of a plane table is the arrangement for maintaining the setting securely, and the central screw is not well adapted to this purpose, whereas the radial clamp, used in all theodolites, is admirable. The old and heavier stand cameras had such a fitting, but since these are not common now it might have to be specially

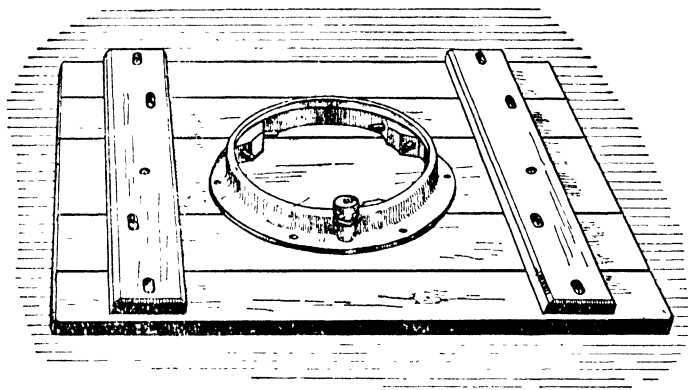

Fig. 74

made. The design in fig. 74 is an example. The turntable can either be permanently screwed to the table itself, the legs of the tripod in that case being removable, as in the figure, or the legs may be connected to the turntable which is then inserted into a recess on the under side of the table.

Variations in the design will occur to anyone with a turn for carpentry, who may be cheered by the fact that the author in 1934 constructed a successful if rather small plane-table outfit entirely out of items bought over the counter at a famous one-price store, the net outlay, including material for an alidade, being 8s. 6d. It is not seriously suggested that sixpenny bread platters as turntables and that curtain-rod

fittings as clamps make for the best efficiency in a plane-table equipment, but it does support the contention that any school workshop should be able to turn out quite a serviceable outfit at small cost.

It is less easy to devise an alidade, though even here a good school ruler with vanes made out of brass hinges has served the purpose well. A clinometer is practically beyond the scope of ordinary amateur workmanship, though a visit to second-hand markets will often produce an article which the practised surveyor could use with some confidence.

It may even be argued that the interest of making small area surveys is increased rather than lessened by having to use instruments which are not "fool-proof", and that the professional with his theodolite measuring to seconds of arc is not really as happy as the schoolboy, who achieves a traverse with a second-hand compass, and endeavours to make up for its deficiencies by devising checks of his own.

Whether this be the case or not, the author may confess on his last page that the aim of his book is not so much the teaching of simple methods of surveying as of persuading his readers that the making of such maps can be an enthralling pastime besides being a useful accessory to scientific work. The desire to achieve maps of small areas is latent in most schoolboys and in many students, and if this book has shown that it is possible for anyone to fulfil that desire by simple instruments and methods, it will have served its purpose.

APPENDIX

LETTERING

The amateur surveyor must reduce the time it takes to letter the names on his maps by any means which will ensure uniformity, neatness and despatch.

Stencilling is one such means and though it is by no means so rapid as manuscript lettering, it scores in being very neat. The stencilled alphabets cut in transparent celluloid and used in conjunction with cylindrical nibs are very convenient for the purpose, but they are not very easy to manipulate in the really small sizes.

In any case the surveyor will constantly have to put in names in manuscript and the following brief and somewhat unorthodox suggestions may be of some value to the beginner.

He should not attempt to copy the style of lettering used in printed maps, which are built up with many strokes of the pen, but should adopt some style of written letters which are, in slope and formation, a reasonable approximation to his usual style of writing.

He should aim particularly at keeping the same slope for all letters in a name and use guide lines in pencil for this, and for keeping the height of the letters uniform.

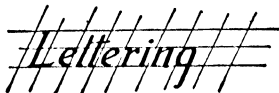

For small letters it is probably best not to attempt to get variation in the thickness of up



and down strokes, but to use a ball-pointed nib or a stylograph pen.

For larger lettering the thickness can be varied by using a flat-pointed nib, not by a flexible nib which spreads under pressure.

For most people a sloping letter comes more naturally and if the flat-pointed pen is held at the same angle to the line for all letters it will produce thick lines in one direction, and thin in a direction at right angles so that a pleasing variation is given automatically.

Such a method of using the pen produces what may be called Manuscript Italic Lettering in the style of the alphabet below.

ABCDEFGHIJK
LMNOPQRSTU
VWXYZ 
abcdefghijklmnopqrs
tuvwxyz abcdefijklmn
123456789

Should the normal handwriting be nearly vertical and with rounded letters it may be found easier to adopt an approximation to the Manuscript Roman alphabet, reproduced on the next page.

There need be no slavish copying of these or other alphabets as to the forms of the letters, it is sufficient for the mapper to aim at legibility and neat appearance first. Improvement will come rapidly if, when opportunity offers, the pencilled

ABCDEFGHIJK
 LMNOPQQRST
 UVWXYZ. 
 aabcdefghijklmnop
 qrstuvwxyz  serifs !? &
 abcdefghijklmnop
 rstu
 vwxyz 123456789

field notes are lettered instead of written, which soon accustoms the hand to keeping a regular size and slope of lettering, the first requisite in neatness.

There are certain fundamentals in lettering, which, for the benefit of the beginner, can be put down in a list.

(i) Capitals and small letters must never be mixed.

(ii) Spacing of letters is nearly as important as slope. As a general rule the rounded letters should be closer together than the straight letters. Compare the words below where

Even spacing *Woolloomoolloo*

Round letters
closer than
straight letters *Woolloomoolloo*

the ill appearance due to neglect of this general instruction is self evident.

(iii) Titles in large lettering will have to be built up by several strokes of the pen. In this case, and in others until practice has made it unnecessary, the whole name should be pencilled first.

APPENDIX II

CONVENTIONAL SIGNS

Everyone is familiar with the conventional signs in common use on topographical maps such as those of the Ordnance Survey. These have stood the test of time and should be used where it is possible to do so: the same thing applies to those signs found in military manuals.

Nevertheless the surveyor of small areas on the large scales used in this book will find that he will be needing new signs, both to accord with his scale, and because the detail he is surveying will often be either technical or of a character which does not come into ordinary cartographic usage. It is of some importance that such detail should be shown in a way that can be understood by the map user without constant consultation of the map legend.

To secure uniformity of signs with different workers is probably impossible at present, but if the general principles are stated and illustrated it should be easier for them to produce common factors in their signs which will tend towards uniformity in time.

Conventional signs should be neat, easy to execute, unlikely to obscure other detail, and in particular, they should aptly represent the objects they refer to. These attributes are illustrated very well by the usual signs for railways on topographic maps, and shoals on Admiralty charts, to quote two examples.

Usually the sign has to represent the exact location of an object as well as its nature, as in these two cases, but very often its position is of minor importance, and it indicates the

existence of a feature rather than its actual shape or area, or position in plan. Tree signs for instance will rarely be required to mark the precise spot where a tree grows, rock signs are

BOUNDARIES

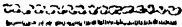

Hedge and Ditch



Hedge



Wire

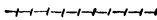

Post and Rail



Iron Railing



Masonry Wall

VEGETATION



Deciduous Trees to decreasing Scales



Coniferous Trees

Orchards



Arable



Pasture

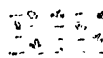

Heath



Low Scrub



Marsh



Salt Marsh

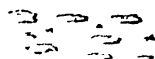

Moor

similar, but if they are accurate in this respect it is advisable either to state the fact in the legend or to alter the sign in some way to indicate that it is accurately placed.

The Use of Colour

Where colour washes can be used, that is to say, when the map is not going to be reproduced in print, they afford the best and quickest means of representing distributions of

WATER

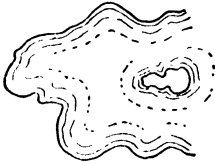

Lake



Tarns



Tidal Flats



Rapids

Falls

Eddies

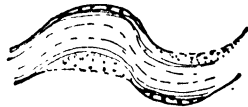

Cut Banks and Gravel



Shore line
Large Scale



Smaller Scale

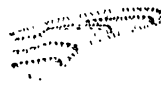

Shingle Spit



Shingle Bank

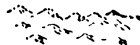
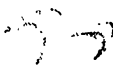
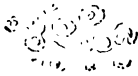

Sand dunes to different Scales

almost any kind, though they are not so successful in representing isolated objects.

Its counterpart for printing purposes, namely cross-hatching and stippling, is not nearly so satisfactory, since it is tedious to do and tends to obscure the detail. It should be remembered

that the printer can, by mechanical means, put a variety of hatchings and stipplings on any map if their boundaries are indicated to him.

Topographical signs may be considered under various headings, but it must be remembered that they have to conform to the scale of the map and yet they must not radically change their character for different scales.

It would be impossible to give a comprehensive set of signs to suit all workers. The examples on pp. 230-1 must be taken merely as suggestions, or as representing selection by the author from signs which have stood the test of his own or other people's experience.















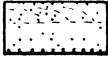
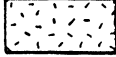
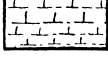

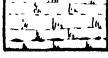

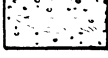
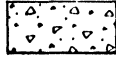
Practically all of them can be used in the field with the pencil, preparatory to the inking in to follow later, and of the alternatives shown that sign should be adopted which best suits the scale and the skill of the surveyor. Nearly all of them are intended for scales larger than 1/10,000, and many would look ridiculous and unsuitable except on scales larger than 1/4000, that is to say, about 100 yd. to the inch. They have all been drawn rapidly and in free hand and with an ordinary pen so that they do not represent expert draughtsmanship so much as what should be possible to anyone of reasonable skill with pen and pencil.

Geological Detail

The geologist has for long adopted a series of signs for his detail which have become fairly well fixed, and these should be followed wherever possible by others who are plotting such detail. The use of coloured crayons in the field is recommended but is not always possible, and it is better to shade the edges only of a geological boundary in the field and not the whole expanse, since that tends to obscure other detail.

When crayons cannot be used it is possible to put in signs in pencil which can either be inked in later or replaced by colour. The signs in the example below are suggested as

easy and useful for indicating the broad categories of rocks, though they would be of little value to the detailed geological surveyor.

	Schists		Clays
	Slates		Shales
	Gneisses		Sandstones
	Igneous		Limestones
	"		Chalk
	"		River Gravels
	Glacial deposits		Horizontal Strata
	Alluvium recent		Vertical
	Alluvium older		Dip and Strike
	Alluvium older		Fault Downthrow
			Syncline
			Anticline

All these have the merit that they are similar to the signs commonly used for representing geological sections, and are therefore easily understood.

APPENDIX III

HOW TO USE THE TRAVERSE TABLES

The traverse tables are really nothing more than a list of the products of the units 1, 2, 3, &c., multiplied by the sine and cosine of the different bearings. They are read downwards from 0° to 45° and upwards from 45° to 90° , noting that what is a Latitude when read downwards becomes a Departure when read upwards.

The best way to take out co-ordinates from the tables is shown by the following two examples, shifting the decimal place according to the value of each digit.

(i) Co-ordinates required for a bearing of 36° and a distance of 149.6 units.

	Lat.	Dep.
100	80.9	58.8
40	32.4	23.5
9	7.3	5.3
.6	.5	.3
149.6	121.1	87.9

(ii) Co-ordinates for a bearing of 59° and distance of 99101 units.

	Lat.	Dep.
90000	46350	77140
9000	4635	7714
100	51.5	85.7
00	0	0
1	.5	.8
99101	51037.0	84940.5

NATURAL TANGENTS

	0'	10'	20'	30'	40'	50'
0°	·0000	0029	0058	0087	0116	0145
1	·0175	0204	0233	0262	0291	0320
2	·0349	0378	0407	0437	0466	0495
3	·0524	0553	0582	0612	0641	0670
4	·0699	0729	0758	0787	0816	0846
5	·0875	0904	0934	0963	0992	1022
6	·1051	1080	1110	1139	1169	1198
7	·1228	1257	1287	1317	1346	1376
8	·1405	1435	1465	1495	1524	1554
9	·1584	1614	1644	1673	1703	1733
10	·1763	1793	1823	1853	1883	1914
11	·1944	1974	2004	2035	2065	2095
12	·2126	2156	2186	2217	2247	2278
13	·2309	2339	2370	2401	2432	2462
14	·2493	2524	2555	2586	2617	2648
15	·2679	2711	2742	2773	2805	2836
16	·2867	2899	2931	2962	2994	3026
17	·3057	3089	3121	3153	3185	3217
18	·3249	3281	3314	3346	3378	3411
19	·3443	3476	3508	3541	3574	3607
20	·3640	3673	3706	3739	3772	3805
21	·3839	3872	3906	3939	3973	4006
22	·4040	4074	4108	4142	4176	4210
23	·4245	4279	4314	4348	4383	4417
24	·4452	4487	4522	4557	4592	4628
25	·4663	4699	4734	4770	4806	4841
26	·4877	4913	4950	4986	5022	5059
27	·5095	5132	5169	5206	5243	5280
28	·5317	5354	5392	5430	5467	5505
29	·5543	5581	5619	5658	5696	5735
30	·5774	5812	5851	5890	5930	5969
31	·6009	6048	6088	6128	6168	6208
32	·6249	6289	6330	6371	6412	6453
33	·6494	6536	6577	6619	6661	6703
34	·6745	6787	6830	6873	6916	6959
35	·7002	7046	7089	7133	7177	7221
36	·7265	7310	7355	7400	7445	7490
37	·7536	7581	7627	7673	7720	7766
38	·7813	7860	7907	7954	8002	8050
39	·8098	8146	8195	8243	8292	8342
40	·8391	8441	8491	8541	8591	8642
41	·8693	8744	8796	8847	8899	8952
42	·9004	9057	9110	9163	9217	9271
43	·9325	9380	9435	9490	9545	9601
44	·9657	9713	9770	9827	9884	9942

NATURAL TANGENTS

	0'	10'	20'	30'	40'	50'
45°	1 000	0058	0117	0176	0235	0295
46	1 035	0416	0477	0538	0599	0661
47	1 072	0786	0850	0913	0977	1041
48	1-111	1171	1237	1303	1369	1436
49	1-150	1571	1640	1708	1778	1847
50	1-192	1988	2059	2131	2203	2276
51	1-235	2423	2497	2572	2647	2723
52	1-280	2876	2954	3032	3111	3190
53	1 327	3351	3432	3514	3597	3680
54	1-376	3848	3934	4019	4106	4193
55	1-428	4370	4460	4550	4641	4733
56	1-483	4919	5013	5108	5204	5301
57	1-540	5497	5597	5697	5798	5900
58	1 600	6107	6212	6319	6426	6534
59	1-664	6753	6864	6977	7090	7205
60	1 732	7437	7556	7675	7796	7917
61	1 804	8165	8291	8418	8546	8676
62	1-881	8940	9074	9210	9347	9486
63	1 963	9768	9912	0057	0204	0353
64	2 050	0655	0809	0965	1123	1283
65	2 144	1609	1775	1943	2113	2286
66	2 246	2637	2817	2998	3183	3369
67	2 356	3750	3945	4142	4342	4545
68	2 475	4960	5172	5386	5605	5826
69	2 605	6279	6511	6746	6985	7228
70	2-747	2 773	2 798	2 824	2 850	2-877
71	2 904	2 932	2 960	2-989	3 018	3-047
72	3 078	3-108	3 140	3-172	3 204	3-237
73	3 271	3 305	3-340	3 376	3 412	3-450
74	3 487	3-526	3-566	3-606	3-647	3-689
75	3 732	3 776	3 821	3 867	3-914	3 962
76	4-011	4 061	4-113	4 165	4-219	4-275
77	4 331	4 390	4 449	4 511	4-574	4-638
78	4-705	4 773	4 843	4-915	4 989	5-066
79	5-145	5-226	5-309	5-396	5-485	5-576
80	5 671	5-769	5 871	5-976	6 084	6-197
81	6-314	6 435	6 561	6-691	6-827	6-968
82	7-115	7-269	7-429	7 596	7-770	7-953
83	8-144	8 345	8 556	8-777	9-010	9-255
84	9-514	9-788	10 08	10-39	10 71	11-06
85	11-43	11 83	12-25	12-71	13-20	13-73
86	14-30	14-92	15 60	16-35	17 17	18 07
87	19-08	20 21	21 47	22 90	24-54	26-43
88	28-64	31-24	34-37	38-19	42-96	49-10
89	57-29	68-75	85 94	114-6	171-9	343-8

	Chords	Sine	Tangent	Cotangent	Cosine		
1°	·017	·0175	·0175	57·2900	·9998	1·402	89°
2	·035	·0349	·0349	28·6363	·9994	1·389	88
3	·052	·0523	·0524	19·0811	·9986	1·377	87
4	·070	·0698	·0699	14·3006	·9976	1·364	86
5	·087	·0872	·0875	11·4301	·9962	1·351	85
6	·105	·1045	·1051	9·5144	·9945	1·338	84
7	·122	·1219	·1228	8·1443	·9925	1·325	83
8	·139	·1392	·1405	7·1154	·9903	1·312	82
9	·157	·1564	·1584	6·3138	·9877	1·299	81
10	·174	·1736	·1763	5·6713	·9848	1·286	80
11	·192	·1908	·1944	5·1446	9816	1·272	79
12	·209	·2079	·2126	4·7046	·9781	1·259	78
13	·226	·2250	·2309	4·3315	·9744	1·245	77
14	244	·2419	·2493	4·0108	·9703	1·231	76
15	·261	·2588	·2679	3·7321	·9659	1·217	75
16	·278	·2756	·2867	3·4874	·9613	1·204	74
17	·296	·2924	·3057	3·2709	9563	1·190	73
18	·313	·3090	·3249	3·0777	·9511	1·176	72
19	·330	·3256	·3443	2·9042	·9455	1·161	71
20	·347	·3420	·3640	2·7475	·9397	1·147	70
21	·364	·3584	3839	2·6051	·9336	1·133	69
22	·382	·3746	·4040	2·4751	·9272	1·118	68
23	·399	·3907	·4245	2·3559	·9205	1·104	67
24	·416	·4067	·4452	2·2460	9135	1·089	66
25	·433	·4226	·4663	2·1445	·9063	1·075	65
26	·450	·4384	·4877	2·0503	8988	1·060	64
27	·467	·4540	·5095	1·9626	·8910	1·045	63
28	·484	·4695	·5317	1·8807	·8829	1·030	62
29	·501	·4848	·5543	1·8040	·8746	1·015	61
30	·518	·5000	·5774	1·7321	·8660	1·000	60
31	·534	·5150	·6009	1·6643	·8572	·985	59
32	·551	·5299	·6249	1·6002	8480	·970	58
33	·568	·5446	6494	1·5399	·8387	·954	57
34	·585	·5592	6745	1·4826	·8290	·939	56
35	·601	·5736	·7002	1·4281	·8192	·923	55
36	618	·5878	·7265	1·3764	·8090	·908	54
37	·635	·6018	·7563	1·3270	·7986	·892	53
38	·651	·6157	·7813	1·2799	·7880	·877	52
39	·668	·6293	·8098	1·2349	·7771	·861	51
40	·684	·6428	·8391	1·1918	·7660	·845	50
41	·700	·6561	·8693	1·1504	·7547	·829	49
42	·717	·6691	·9004	1·1106	·7431	·813	48
43	·733	·6820	·9325	1·0724	·7314	·797	47
44	·749	·6947	·9657	1·0355	·7193	·781	46
45	·765	·7071	1·0000	1·0000	·7071	·765	45
		Cosine	Cotangent	Tangent	Sine	Chords	

TRAVERSE TABLES

DISTANCE UNITS

Bearing	1		2		3		4		5		6		7		8		9		Bearing
	Lat	Dep	Lat	Dep	Lat	Dep	Lat	Dep	Lat	Dep	Lat	Dep	Lat	Dep	Lat	Dep	Lat	Dep	
0	1 000	0 000	2 000	0 000	3 000	0 000	4 000	0 000	5 000	0 000	6 000	0 000	7 000	0 000	8 000	0 000	9 000	0 000	0
30	1 000	0 008	1 999	0 017	2 997	0 026	3 993	0 035	4 989	0 044	5 983	0 053	6 975	0 062	7 965	0 071	8 953	0 080	30
1	0 999	0 017	1 999	0 035	2 999	0 052	3 999	0 070	4 999	0 087	5 999	0 105	6 999	0 122	7 999	0 140	8 999	0 157	89
30	0 999	0 017	1 999	0 035	2 999	0 052	3 999	0 070	4 999	0 087	5 999	0 105	6 999	0 122	7 999	0 140	8 999	0 157	30
45	0 995	0 035	1 999	0 070	2 998	0 105	3 996	0 140	4 993	0 175	5 989	0 210	6 983	0 245	7 975	0 279	8 965	0 314	88
30	0 995	0 044	1 998	0 087	2 997	0 131	3 996	0 174	4 995	0 218	5 994	0 262	6 992	0 305	7 992	0 349	8 991	0 393	30
60	0 959	0 052	1 957	0 105	2 956	0 157	3 954	0 209	4 952	0 262	5 950	0 314	6 947	0 366	7 943	0 418	8 938	0 470	87
30	0 959	0 061	1 996	0 122	2 994	0 183	3 992	0 244	4 991	0 305	5 989	0 366	6 987	0 427	7 985	0 488	8 983	0 549	30
45	0 959	0 070	1 995	0 139	2 993	0 209	3 990	0 279	4 988	0 349	5 985	0 419	6 983	0 488	7 980	0 558	8 978	0 628	86
30	0 957	0 078	1 994	0 157	2 991	0 235	3 988	0 314	4 985	0 392	5 981	0 471	6 978	0 549	7 975	0 628	8 972	0 706	30
60	0 956	0 087	1 992	0 174	2 989	0 261	3 985	0 349	4 981	0 436	5 977	0 523	6 973	0 610	7 970	0 697	8 966	0 784	85
30	0 955	0 096	1 991	0 192	2 986	0 287	3 982	0 383	4 977	0 479	5 972	0 575	6 968	0 671	7 963	0 767	8 959	0 863	30
75	0 934	0 104	1 989	0 209	2 984	0 314	3 978	0 418	4 973	0 523	5 967	0 627	6 962	0 732	7 956	0 836	8 951	0 941	84
30	0 934	0 112	1 987	0 226	2 981	0 340	3 974	0 453	4 966	0 566	5 961	0 679	6 955	0 792	7 949	0 906	8 942	1 019	30
45	0 932	0 122	1 985	0 244	2 978	0 366	3 970	0 487	4 965	0 608	5 959	0 731	6 946	0 853	7 940	0 975	8 933	1 097	83
30	0 931	0 130	1 983	0 261	2 974	0 392	3 966	0 522	4 957	0 653	5 949	0 783	6 940	0 914	7 934	1 044	8 927	1 175	30
60	0 930	0 139	1 980	0 278	2 971	0 417	3 961	0 557	4 951	0 696	5 942	0 835	6 932	0 974	7 922	1 112	8 912	1 253	82
30	0 929	0 148	1 978	0 296	2 967	0 443	3 956	0 591	4 945	0 739	5 934	0 887	6 922	1 025	7 912	1 182	8 901	1 338	30
9	0 928	0 156	1 975	0 313	2 963	0 469	3 951	0 626	4 938	0 782	5 926	0 939	6 914	1 085	7 901	1 251	8 889	1 408	81
30	0 926	0 165	1 973	0 330	2 959	0 495	3 945	0 656	4 931	0 828	5 918	0 990	6 904	1 155	7 890	1 328	8 877	1 485	30
45	0 925	0 174	1 970	0 347	2 954	0 521	3 939	0 695	4 924	0 868	5 909	1 042	6 894	1 215	7 878	1 398	8 862	1 563	80
30	0 923	0 182	1 968	0 364	2 950	0 547	3 933	0 729	4 918	0 911	5 899	1 093	6 883	1 276	7 866	1 459	8 849	1 646	30
60	0 922	0 191	1 965	0 382	2 945	0 572	3 926	0 763	4 910	0 954	5 890	1 145	6 871	1 326	7 853	1 528	8 835	1 717	79
30	0 920	0 199	1 963	0 400	2 940	0 598	3 920	0 797	4 899	0 997	5 879	1 196	6 859	1 386	7 838	1 585	8 814	1 784	30
75	0 917	0 208	1 956	0 416	2 934	0 624	3 913	0 832	4 891	1 040	5 869	1 247	6 847	1 455	7 825	1 663	8 803	1 891	78
30	0 916	0 216	1 953	0 433	2 929	0 649	3 905	0 866	4 881	1 092	5 856	1 299	6 834	1 513	7 811	1 731	8 787	1 948	30
45	0 914	0 225	1 949	0 450	2 923	0 675	3 897	0 900	4 872	1 125	5 846	1 350	6 821	1 575	7 795	1 800	8 769	2 025	77
30	0 912	0 233	1 945	0 467	2 917	0 701	3 889	0 934	4 862	1 157	5 834	1 401	6 807	1 634	7 779	1 868	8 751	2 101	30
60	0 910	0 241	1 941	0 484	2 910	0 728	3 881	0 968	4 851	1 210	5 822	1 451	6 795	1 682	7 763	1 933	8 737	2 177	76
30	0 908	0 250	1 938	0 501	2 904	0 751	3 873	0 101	4 841	1 252	5 809	1 502	6 777	1 783	7 745	2 009	8 713	2 253	30
75	0 906	0 259	1 932	0 518	2 898	0 776	3 864	1 035	4 830	1 294	5 796	1 553	6 761	1 812	7 727	2 071	8 683	2 329	30
30	0 904	0 267	1 927	0 534	2 891	0 802	3 854	1 069	4 818	1 338	5 782	1 603	6 745	1 871	7 709	2 139	8 673	2 405	30
45	0 901	0 276	1 922	0 551	2 883	0 827	3 845	1 102	4 806	1 378	5 768	1 654	6 728	1 929	6 690	2 205	8 651	2 481	74
30	0 900	0 284	1 918	0 568	2 876	0 852	3 835	1 136	4 794	1 420	5 753	1 704	6 712	1 988	6 671	2 272	8 629	2 556	30
60	0 898	0 293	1 913	0 585	2 869	0 877	3 825	1 169	4 781	1 462	5 738	1 754	6 684	2 047	6 658	2 335	8 607	2 631	73
30	0 894	0 301	1 907	0 601	2 861	0 902	3 815	1 203	4 769	1 503	5 722	1 804	6 676	2 105	6 630	2 408	8 583	2 706	30
75	0 891	0 309	1 902	0 618	2 853	0 927	3 804	1 236	4 755	1 545	5 706	1 854	6 657	2 163	6 608	2 472	8 559	2 781	72
30	0 890	0 317	1 897	0 635	2 845	0 952	3 793	1 269	4 742	1 586	5 690	1 904	6 638	2 221	6 579	2 538	8 535	2 856	30
45	0 885	0 326	1 891	0 651	2 837	0 977	3 782	1 302	4 728	1 628	5 673	1 953	6 618	2 279	6 564	2 604	8 510	2 930	71
30	0 883	0 334	1 885	0 668	2 829	1 002	3 771	1 335	4 713	1 669	5 656	2 002	6 604	2 336	6 549	2 671	8 487	3 004	30
60	0 880	0 342	1 879	0 684	2 819	1 026	3 759	1 368	4 698	1 710	5 638	2 052	6 578	2 394	6 517	2 734	8 455	3 076	30
30	0 877	0 350	1 873	0 700	2 810	1 051	3 747	1 401	4 683	1 751	5 620	2 101	6 557	2 451	6 493	2 802	8 430	3 152	30
75	0 874	0 358	1 867	0 717	2 801	1 075	3 734	1 433	4 668	1 792	5 601	2 150	6 535	2 509	6 469	2 867	8 402	3 225	69
30	0 873	0 366	1 861	0 733	2 791	1 099	3 722	1 466	4 652	1 832	5 582	2 199	6 513	2 565	6 443	2 932	8 374	3 298	30
45	0 870	0 375	1 854	0 749	2 782	1 124	3 709	1 498	4 636	1 873	5 563	2 248	6 490	2 622	6 417	2 997	8 345	3 371	68
30	0 868	0 384	1 848	0 765	2 772	1 148	3 695	1 531	4 619	1 913	5 543	2 296	6 467	2 679	6 391	3 061	8 315	3 444	30
60	0 865	0 391	1 841	0 781	2 761	1 172	3 682	1 563	4 602	1 954	5 523	2 344	6 443	2 735	6 364	3 126	8 284	3 517	67
30	0 863	0 399	1 834	0 797	2 751	1 196	3 668	1 595	4 585	1 994	5 502	2 392	6 419	2 791	6 336	3 190	8 253	3 589	30
75	0 860	0 407	1 827	0 813	2 741	1 220	3 654	1 627	4 568	2 034	5 481	2 446	6 395	2 847	6 308	3 254	8 222	3 661	66
30	0 858	0 415	1 820	0 829	2 730	1 244	3 640	1 659	4 550	2 073	5 460	2 488	6 370	2 903	6 280	3 317	8 190	3 732	30
45	0 856	0 423	1 813	0 845	2 719	1 268	3 625	1 690	4 531	2 113	5 438	2 536	6 344	2 958	6 250	3 381	8 157	3 804	30
30	0 853	0 430	1 805	0 861	2 708	1 293	3 610	1 720	4 513	2 153	5 415	2 576	6 318	3 011	6 221	3 443	8 123	3 875	30
60	0 850	0 438	1 798	0 877	2 698	1 315	3 595	1 753	4 494	2 193	5 393	2 620	6 292	3 069	6 190	3 507	8 089	3 945	30
30	0 855	0 446	1 790	0 892	2 685	1 339	3 580	1 785	4 475	2 231	5 370	2 677	6 264	3 123	6 159	3 570	8 054	4 018	30
75	0 851	0 454	1 782	0 908	2 673	1 362	3 564	1 816	4 455	2 270	5 346	2 724	6 237	3 178	6 128	3 630	8 019	4 086	63
30	0 847	0 462	1 774	0 923	2 661	1 385	3 548	1 847	4 435	2 309	5 322	2 770	6 209	3 232	6 096	3 684	7 983	4 156	30
45	0 843	0 469	1 766	0 939	2 649	1 408	3 532	1 878	4 415	2 347	5 298	2							

INDEX

A

- Abney level, 110, 119, 128, 220.
- Adjustment of plotting, 81, 87
- Aerial photographs, 200
- Alidade, 135, 224.
 - telescopic, 183.
- Allowance for slopes, 39
- Aneroid barometer, 103
- Arrows, 38, 213

B

- Back bearings, 66.
- Backsight, 121.
- Band, steel, 36.
- Base line, 5, 62, 148.
- Bench mark, 115.
- Booking, 43, 52, 76, 107, 123.

C

- Chaining, 36, 48.
- Chains, 212.
- Clinometer, 103, 107, 207, 215, 217, 224.
 - Indian, 167, 221.
 - Watkins, 109, 218.
- Colour wash, 26, 28, 231.

- Compass, prismatic, 57, 207, 214.
 - traverse, 73.
 - trough, 164, 217.
 - sketch, 61.
- Conscience, need for, in plane tabling, 151.
- Contours, 9, 102, 188, 189.
- Control, 5, 147.
- Conventional signs, 8, 157, 229.
- Co-ordinates, plotting by, 83.
- Cyclometer, 35.

D

- Danger circle, 162.
- Detail, 4, 6, 20.
- Diaphragm, 185.
- Dividers, 209.

E

- Errors in chaining, 40.
 - in levelling, 123.
 - in plane tabling, 178.
 - of closure, 79, 80.
 - of collimation, 121.
 - of compass, 60-4.
- Exploratory traverse, 91.
- work, 196.

F

Field equipment, 210.
 Focal length, 194.
 Foresight, 121.
 Form-lines, 9, 11, 102.
 Framework, 3, 4, 5, 142, 147.

G

Geometrical square, 204.
 Grid, perspective, 200, 202.

H

Hachures, 101.
 Hand level, 119, 128.
 Height, determination of, 101,
 169.
 Horizontal equivalent, 32.

I

Index error, 111.
 Indian ink, 25.
 Intermediate sights, 125.
 Intersection, plane tabling, 62,
 140.
 — photographic survey, 197.

L

Layer colouring, 102.
 Lay out, 48, 51.
 Lettering, 28, 225.
 Levelling, 103, 117.
 Line, fineness of, 17.

M

Mosaic of photographs, 202.

O

Obstacles, 41.

Offsets, 36, 48.
 Offset scale, 83.
 Orientation, 67, 139, 150, 151.

P

Pacing, 33, 51.
 Panoramas, 199.
 Paper, drawing, 25, 175.
 Parallax, 179.
 Pedometer, 34.
 Pencil work, 22.
 Pens, 26, 225.
 Perspective camera, 194 200.
 — grid, 200.
 Picture trace, 197.
 Plane table, 133, 221, 223.
 Plottable error, 21, 148, 178,
 186, 188.
 Plotting, 23.
 — a traverse, 78.
 — from photographs, 197.
 Points, first class, 65, 141, 150,
 151, 165.
 Protractor, 23, 67, 79.

R

Radial method, 143.
 Range pole, 74, 212.
 Resection, 66, 144, 153, 200.
 Right angles, setting out, 42.
 Rope and sound traverse, 90.
 Ruler, 2, 3, 209.

S

Scale, 6, 15, 142, 231.
 — cardboard, 83, 169.

Scale, choice of, 19.
— — for plane tabling, 187.
— line, 23, 24.
Sight rule, 135.
Simple chain surveys, 47.
Sketching, 7, 8.
— board, 209.
Slope method for contours, 116.
Slopes, 31, 39.
Spot heights, 101, 115.
Standard, 37.
Station pointer, 156, 200.
Stereo viewer, 203.
Subtense method, 185.

T

Tacheometry, 186.
Tangents, 114, 236.
Tape, linen, 213.
— steel, 40, 212.

Temperature correction, 106.
Time and rate, 35, 92
Traverse, 5, 73.
— by boat, 93.
— by lorry, 95.
— plane table, 144.
— plotting, 78.
Trial and error, 156.
Triangles, 47, 48.
— of error, 65, 157, 158.
— of uncertainty, 141.
Triangulation, 4, 5.
— plane table, 145, 153.
Tripod, plane table, 136, 221.
Trough compass, 135, 217.
Topographic mapping, 6.

W

Wadstick, 211.
Wheel measurement, 34.

