

UNIVERSAL  
LIBRARY

**OU 162296**

UNIVERSAL  
LIBRARY



**OSMANIA UNIVERSITY LIBRARY**

Call No. 589.95 Accession No. 12158

Author E47P  
Ellis, David

Title Practical Bacteriology

This book should be returned on or before the date last marked below.



PRACTICAL BACTERIOLOGY  
FOR CHEMICAL STUDENTS



# PRACTICAL BACTERIOLOGY

## FOR CHEMICAL STUDENTS

BY

DAVID ELLIS

Ph. D., D. Sc., F. R. S. E.

HEAD OF THE DEPARTMENT OF BACTERIOLOGY AND BOTANY  
IN THE ROYAL TECHNICAL COLLEGE, GLASGOW

*WITH ILLUSTRATIONS*

LONGMANS, GREEN AND CO.

39 PATERNOSTER ROW, LONDON, E. C. 4

NEW YORK, TORONTO

BOMBAY, CALCUTTA AND MADRAS

1923



## PREFACE.

The exercises detailed in this book are those which are followed in the writer's classes in preparation for the Degree of Applied Chemistry in the University of Glasgow and for the Diploma in the same subject at the Royal Technical College, Glasgow. In the study of Chemistry there are many avenues of research which are closed to the intending investigator owing to a lack of knowledge of the elementary principles of bacteriology. It is hoped that this small book will suffice to give the trained chemist enough guidance to enable him to master the general principles of this subject, preparatory to the investigation of problems of a purely chemical nature which owe their incidence to the activities of bacteria and other micro-organisms. The writer knows from his own experience again and again that Works Chemists have been brought to a standstill in the prosecution of their work when confronted with a problem of vital interest to their employers which they cannot tackle, not from want of chemical training, but from ignorance of the rudiments of Bacteriology. Whilst the general aim of this book has been directed towards satisfying the needs of chemical students, the exercises are suitable for all who desire to obtain a grounding in the general principles of the subject, no matter from which angle they propose to approach the subject in their subsequent investigations.

*Royal Technical College, Glasgow.*

**David Ellis.**

*Jan. 1923.*



## CONTENTS.

CHAPTER	PAGE
I. Bacteriological apparatus, Steam-steriliser: Hot-air oven; Autoclave: Incubator: Small apparatus required by each student: Hints to students . . . . .	1
II. Preparation of Nutrient-media. Sterilisation of Apparatus . . . . .	14
III. Agar-plate culture: Agar-slope culture: Gelatine-plate culture: Gelatine stab culture: Gelatine shake culture: broth culture. Revision . . . . .	23
IV. The Staining of Bacteria. Use of Aniline dyes. Preparation of Stains. Dry-film staining. Wet Staining. Irrigation dry-film method. Hanging-drop preparation . . . . .	34
V. Identification and Staining of Spores. Staining of cilia. Germination of Spores. Capsule staining. Contact preparation . . . . .	42
VI. Reserve food materials. Volutin, glycogen and oil-globules. Gas production. Acid production. Indol production. Milk cultures . . . . .	52
VII. Anaerobic bacteria. Methods of plating and of cultivating anaerobic bacteria. Methods of estimating the size of bacteria and of other minute objects. Production of $H_2S$ in bacteria. Milk Cultures . . . . .	63
VIII. The Isolation of bacteria from soil, from hay-infusion and from air. Counting of Colonies. Estimation of rate of movement of bacteria. Medium for cultivation of chromogenic bacteria . . . . .	78
IX. Examination of Drinking Water. Identification of <i>Bac. coli communis</i> . Total count of bacteria in drinking water. Methods of search for <i>Bac. enteritidis sporogenes</i> . . . . .	86

CHAPTER	PAGE
X. Methods of Examination of Sewage. Dilution of Sewage: Total-count: Number of Bac. coli in Sewage: Indol-tests: Examination for Bac. enteritidis . . .	95
XI. Yeasts: Nutrient-media: Structure of Yeast: Gas-production: Examination of Gas: Alcohol Production: Pure Culture methods: Preparation of marked cover-glasses: Moist-chamber experiments: Fermentation of Sugars: Determination of efficiency of Yeasts: Preservation of Yeasts . . . . .	106
XII. Moulds: Examination of impure Mucor: Examination of impure Penicillium: Germination of spores: Methods of spore-location: Pure culture of Mucor mucedo: Culture-media for Fungi: Identification of commoner Moulds: Acidity-changes produced by moulds: Infection of fruit with mould . . . . .	117
APPENDIX . . . . .	127
INDEX . . . . .	129

## CHAPTER I.

Bacteriological apparatus, Steam-steriliser: Hot-air oven:  
Autoclave: Incubator: Small apparatus required by each  
student: Hints to students.

### Bacteriological Apparatus: Hints to Beginners.

An ordinary chemical laboratory contains most of the apparatus in use in laboratories for the culture of micro-organism. Some special apparatus is required, however, and it is recommended that the following be procured.

(a) *Steam-Steriliser.* Any vessel containing water and provided with a lid will serve as a steam steriliser. When the vessel is heated from underneath, the steam which arises fills the space inside the vessel and sterilises any apparatus which is placed inside. In practice the vessel is made of a cylindrical form, lined with felt or asbestos on the outside, and provided with a perforated false bottom on which the apparatus to be sterilised is placed. An example of a steriliser of this kind is shown in Fig. 1.

In some forms of the apparatus there is a double wall and the steam after filling the chamber is made to issue between the two walls, returning to, and being condensed in, the water from which it issued. This arrangement

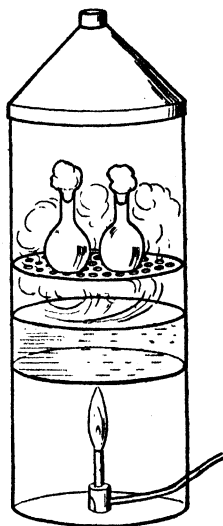

Fig. 1. — Steam steriliser.

prevents a proportion of the steam from issuing into the room. If possible steam sterilisers should not be placed in the working laboratory.

If there are only one or two small things to be sterilised, a fairly large pan, e. g. saucepan fitted with a lid can be used as a steam steriliser. An inch of water is placed in the pan,

a soup-plate upside down is placed in the water, and the objects to be sterilised are set on the upturned bottom of the soup-plate.

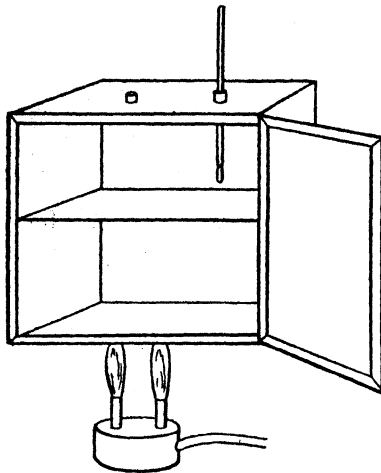

Fig. 2. — Hot Air Oven.

(b) *Hot-Air Oven.* Any sheet-iron box will serve the purpose, so long as the sheets are not fixed together with solder, and can stand heat without coming apart. (Fig. 2.)

(c) *Autoclave.* This apparatus is a steam steriliser from which the steam does not escape when the contained water is heated with the result that the pressure inside the vessel greatly

increases. As the boiling point of water is dependent on the pressure, being higher with increased pressure, this prevention of the escape of the steam results in the temperature of the water rising far above  $100^{\circ}$  C.—its boiling point at ordinary pressure—before beginning to boil. Attached to the strong lid is a pressure gauge. Knowing the pressure the boiling point of water at that pressure is known from the tables. A safety valve is also attached to the lid, and opens to allow the escape of the steam when the pressure becomes too great for safety. Finally there is an opening in attachment to the safety valve which can be opened or closed by a small screw placed by its side. The various parts of the commonest type of Autoclave are shown in Fig. 3.

Some care must be exercised in working this apparatus.

Proceed as follows:—

1. Place 2 or 3 ins. of water in Autoclave, put in object to be sterilised, then light the burner, keeping the lid *loose* on the top until the chamber is filled with steam.
2. Clamp on the lid.
3. The steam should now be issuing from the vent near the safety-valve (Fig. 3). Close this vent.
4. When the pressure-gauge indicates a pressure which shows that the temperature of the steam lies between  $140^{\circ}$  C. and  $160^{\circ}$  C., a further 10 or 15 minutes should be allowed, when sterilisation may be assumed to have been effected.
5. Open the small vent attached to safety-valve (Fig. 3), *taking care not to stand in front of it when doing so.*
6. The steam comes out with some force. Wait until the pressure is relieved then put out the burner.
7. After cooling, open the autoclave.

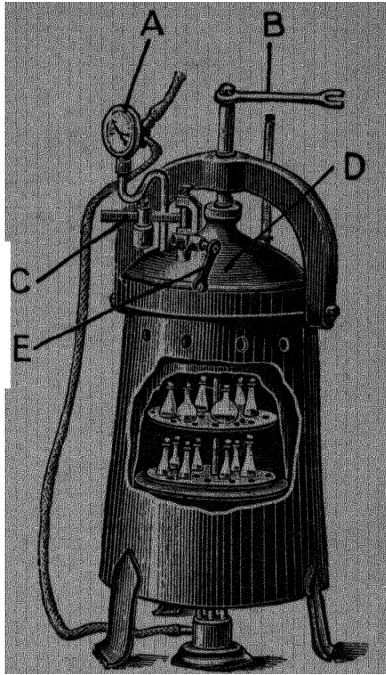

Fig. 3.—Autoclave. As the lid is clamped down in such a way that the steam is prevented from escaping, the pressure rises rapidly. This pressure is measured by the gauge A. C is lever of safety-valve which opens if the pressure becomes too great. B is lever which is used for clamping down the lid D so tightly that no steam escapes. In using the apparatus the steam is allowed to escape for some time through the opening which is opened and closed by turning E before being shut off, in order to ensure that the steriliser is full of steam. When the operation is finished the pressure is released by opening the same vent. As the steam comes out with great force care must be taken not to stand in front of the autoclave when this vent is opened.

(d) *The Incubator.* An incubator is a vessel which contains some arrangement for keeping it at a fixed tempera-

ture. The principle under which all efficient incubators work is the same throughout the various types viz. that an increase in the temperature of the vessel produces some effect which cuts off the source of the heat. Not altogether, however, for a bye-pass is present which keeps up a small flame when the

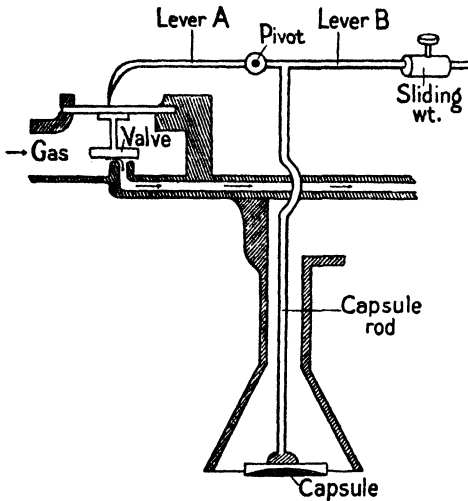

Fig. 4. — Diagrammatic representation of the parts of a gas-valve regulator. The boiling of the liquid in the capsule raises the lever B and depresses the lever A. This closes the valve through which the gas is issuing. The burner is now fed only by the bye-pass. When as a result the temperature falls, the lever B is depressed and the lever A is raised with the result that the gas flows through the valve once more. It is clear that the temperature of the incubator will be approximately the temperature of boiling of the fluid in the capsule. A slight variation can be obtained by shifting the sliding-weight along the lever making this more or less difficult to be raised.

main source of heat is cut off. The vessel cools as a result of the cutting off of the main supply of heat. As this supply has been cut off by the expansion of some substance, the cooling of this substance naturally brings the main supply once more into operation. In this way the temperature cannot go up very far for the main supply is cut off when the temperature reaches a certain point, and cannot go down very far for a lowering of temperature brings it once more into operation.

By far the best of these gas-valves is a type in which

the regulation of gas is effected by a small disc like capsule containing a liquid which boils at a certain fixed temperature. The gas-valve shown in Fig. 4 illustrates this type. See also Fig. 5.

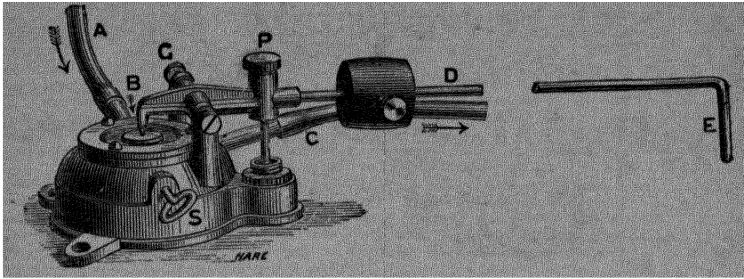

Fig. 5. Regulator of Hearson's Incubator. A Inlet for gas. C Outlet for burner. B to D the lever. G Pivot on which lever works. P Millhead Screw. S Screw needle.

#### *Choice of temperature for cultivation of organisms.*

Every organism has its minimum, optimum and maximum temperatures of growth. It should therefore be the aim of the student to grow a microorganism as near to its optimum temperature as possible. It must be borne in mind, however, that most organisms will grow at the ordinary temperatures of the room, only growth will not in the majority of cases be quite as pronounced as when the organisms are placed inside an Incubator set at a slightly higher temperature. The following temperature-list will serve as rough guide.

Pathogenic bacteria  $37^{\circ}$  C. (The temp. of the body.)

Non-pathogenic bacteria  $28^{\circ}$  C.— $32^{\circ}$  C.

Yeasts  $25^{\circ}$  C. —  $28^{\circ}$ .

Moulds  $30^{\circ}$  C. —  $40^{\circ}$  C.

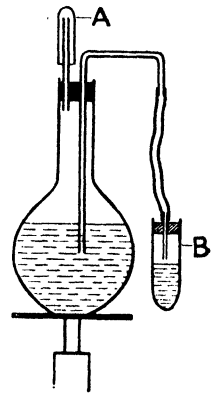

Fig. 6. — Apparatus for keeping sterilised water. Water comes out from the tube B, and the air which displaces the escaping water comes in through the tube inside A. Both ends (A and B) must therefore be protected. End B is placed in a tube containing alcohol. End A is covered by a tube containing usually cotton wool.

*Choice of temperature for cultivation of organisms.*

All micro-organisms do not begin to grow or cease to grow, or grow at their best at the same temperatures. Care should be taken to select an Incubator with a range of temperature which includes the optimum temperature of growth of the class of organisms which it is intended to cultivate.

(e) *Jar for holding Sterile Water.* A very efficient apparatus is that shown in Fig. 6. The all important object is to prevent the water which has been sterilised from receiving subsequent contamination from the micro-organisms of the atmosphere.

(f) *Wire Cages.* Different forms are shown in Fig. 7.

(g) *Special Apparatus for Sterilisation and subsequent protection of Petri-dishes.* (Fig. 8.)

(h) Apparatus that should be in the possession of each student.

1. *Half a dozen Petri-dishes.* (Fig. 9a.)
2. *Platinum needle and Platinum loop.* The Platinum should not be less than 0.015 inch in thickness and should be from 2 to 3 inches long. (Fig. 9b.)
3. *Smith and Durham Fermentation Tubes.* (Fig. 9c.)
4. *Two or three dozen Test-tubes.*
5. *A few Erlenmeyer Flasks* (500 c.c. and 250 c.c. Fig. 9d.)
6. *Graduated Pipettes.*
7. *A few Beakers* (500 c.c. and 250 c.c.).
8. *Two or three Hansen-flasks.* (Fig. 9e.)
9. *Glass Slides and Coverslips.* The coverslip must not be so thick that a high-powered lens e.g. a  $\frac{1}{2}$  inch immersion lens cannot be brought into focus with the object that it covers.

On the other hand if they are very thin the number of casualties during the process of cleaning may be very great.

10. *Receptacles for Glass Slides and Coverslips.* When not in use these articles after being cleaned should be kept in alcohol and taken out only when about to be used. Small glass vessels with ground glass stoppers

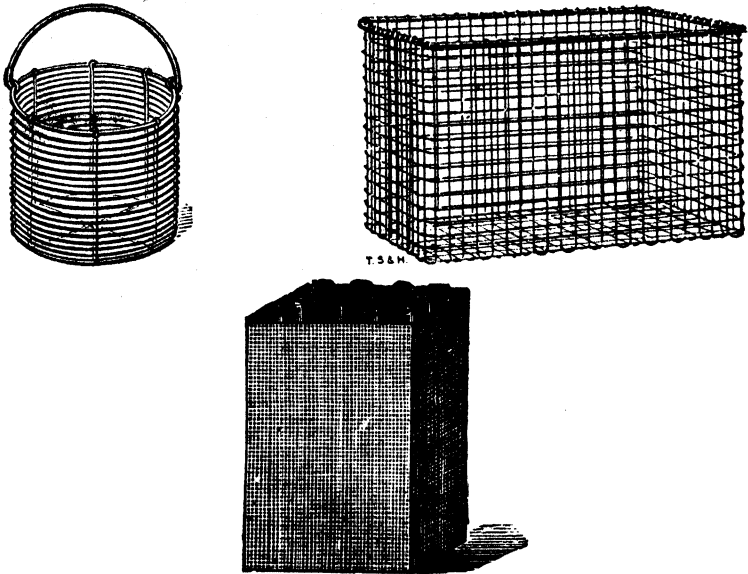

Fig. 7.—Types of wire cages.

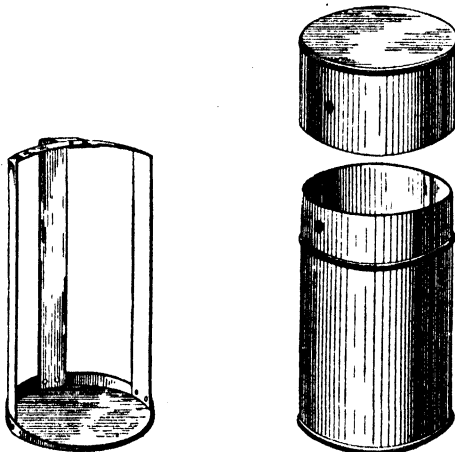

Fig. 8.—Petri-dish Holder. The Petri-dishes are placed in the rack (on left-hand side) the whole being then placed inside the cylindrical vessel. During the period of sterilisation the lid is turned until the hole in the lid is on top of the hole in the lower vessel. After completion of the process of sterilisation a small turn is given to the lid in order that the holes may not be superimposed. This completely cuts off communication with the outside, thus diminishing the risk of contamination from atmospheric organisms.

and wide mouths should be used. Examples are given in Fig. 9 f.

11. Two or three *Drop-bottles*. A very convenient form is shown in Fig. 9 g. When in use the stopper is turned so that there is no communication between the contents of the bottle and the outside air.
12. *A pair of pincers*. The fingers must never come in contact with the flat surface of a slide or coverslip. These must be lifted either by their edges with the fingers, or with the aid of a pair of pincers.
13. A rough duster for general cleaning and a soft one, e. g. an old silk handkerchief or a chamois leather duster for cleaning lenses and coverslips.
14. Glass-pencil.
15. Horn spoon.
16. Two or three glass rods with rounded ends.
17. Receptacle for sterilised test-tubes, e. g. a cigar-box. The receptacle must have a covered lid. Better, however, is the receptacle shown in Fig. 9 h.
18. A box to hold unsterilised test-tubes.
19. Pair of scissors.
20. Two or three glass tumblers.
21. Labels.
22. Litmus paper (Red and blue).
23. Canada Balsam dissolved in xylol.
24. Cedar-wood oil.
25. Bottles containing xylol, alcohol, and the various reagents used in the staining of bacteria.
26. Microscope.
27. Rest for platinum needle and loop (Fig. 9 i).

*Hints.* Before commencing practical work, the student would do well to realise that there is probably no subject in which so much time can be wasted through want of foresight. The chief reasons are.

1. The necessity of incubation puts a period in many cases to a certain class of exercises, and as incubation takes time, the exercise cannot often be finished on the same

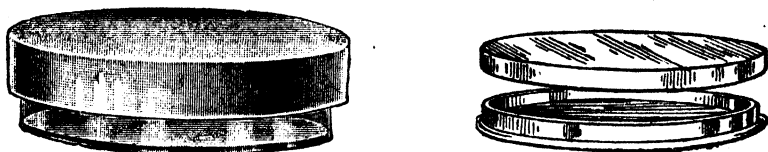

Fig. 9 a. — Petri-dish.



Fig. 9 b. — Upper = Platinum loop. Lower = Platinum needle.

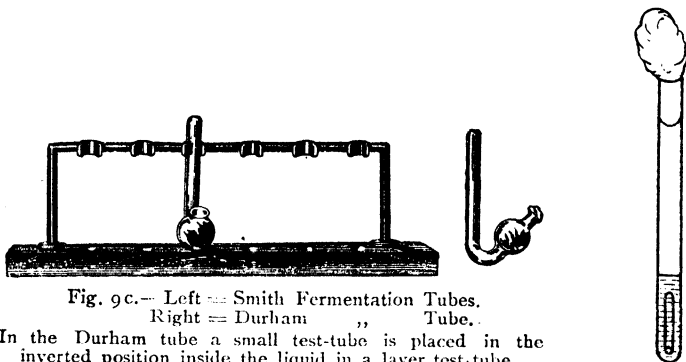

Fig. 9 c. — Left = Smith Fermentation Tubes.  
Right = Durham " Tube.  
In the Durham tube a small test-tube is placed in the inverted position inside the liquid in a layer test-tube.

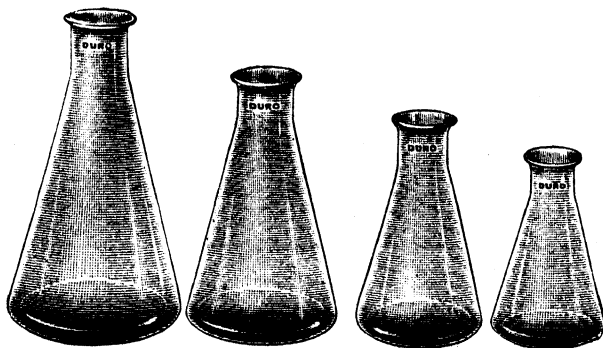

Fig. 9 d. — Erlenmeyer Flasks.

- day as it was begun. A student is therefore 'held up' unless he has the resource to make provision for profitably filling up the time during the period of incubation.
2. Much time is wasted in laboratories because when the student starts an exercise he finds that all the material necessary for the exercise has not been sterilised. He is again 'held up' until the necessary sterilisation has been accomplished.

Hence, never be without sterilised test-tubes, petri-dishes, and flasks, although these may not be immediately wanted.

It is necessary to plot out beforehand the exercises that are going to be attempted during the forthcoming two or three weeks, and provision must be made beforehand for the necessary supply of *sterilised* material. When an exercise cannot be immediately proceeded with because the material must be incubated, another exercise should be begun. The choice of exercise will be greatly facilitated if there is plenty of sterilised material at hand. Failing sterilised material, much time can be profitably filled up by practising the art of staining in its various applications.

Never sterilise in the hot-air oven any glass ware that is not dry.

Bear in mind that the dust in the air contains many microbes and that therefore operations involving the opening of flasks, dishes etc. which contain culture-media, must be done as quickly as possible to prevent contamination by the atmospheric microbes. It is a good rule to remember that there are more microbes on the table than in the air, and more generally on the floor than on the table. Hence the stoppers of flasks, and the platinum needle (or loop) should not be placed on the table during the period when the hands are occupied in transferring material from one flask to another: or in transferring bacteria from one test-tube to another. (See Note or page 23 and Figs 15, 53, 54, 55.)

Never lift a Platinum needle during an exercise without sterilising it, and never put it down again without sterilising it.

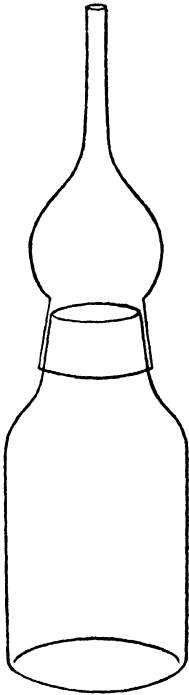

Fig. 9e — Hansen Flask.  
The lower part is an ordinary flask with a ground neck. The upper erection is the hollow stopper, ground in the lower part to fit the neck of the flask and plugged with cotton wool in the upper part.

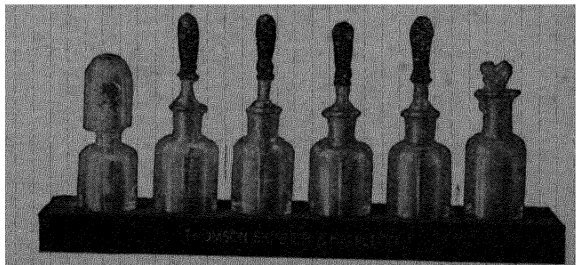

Fig. 9f. — Different types of bottles for holding stains, Canada-balsam, cedar-wood oil etc.

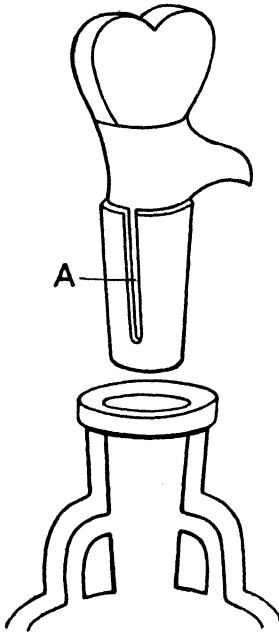

Fig. 9g.—Drop-bottle. When the groove A is in one position, the liquid flows out readily drop by drop. When the groove is in any other position the liquid in the bottle is hermetically closed.

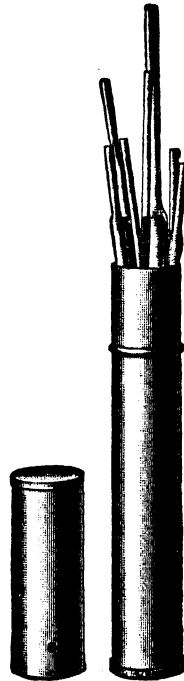

Fig. 9h.—Receptacle for holding sterilised pipettes, burettes etc. It is made on exactly the same principle as the Petri-dish holder (Fig. 8).



Fig. 9i.—Rest for Platinum needle and Platinum loop. Prevents contact of platinum with surface of table.

It is a bad fault to have water on the microscope-table, or on the upper side of the coverslip.

If the immersion-lens is used and cedar-wood oil placed on the lens, this oil should be cleared off, with xylol at the

close of the observation; but care should be taken that the xylol does not remain longer in contact with the lens than is necessary as this substance weakens the lens fittings.

Bring in as little dust as possible into a laboratory and wash out what is already there as often as possible.

A large amount of work is saved by cleaning glass slides and coverslips immediately after the exercise involving their use is finished.

Clean the eye-piece and objective of a microscope with a soft duster. If the view is not clear, examine first the top of the eyepiece and then the bottom of the objective. Careless handling often results in some water escaping from under the coverslip to the top of it, with the result that when the objective is brought down it establishes contact with this water and spoils the view.

Observe the object in focus in the microscope with *both* eyes open. This can be done with a little practice and is much more comfortable than the method of screwing up the face and closing the eye that is not looking down the tube.

Avoid contact of the microscope with all acids, alkalies and other substances that affect metals and glass injuriously.

Write notes at every stage in the work, and make drawings where possible. Enter up the notes in the book before some of the details are forgotten.

## CHAPTER II.

Preparation of Nutrient-media. Sterilisation of Apparatus.

### Exercise I. *Preparation of Nutrient-Gelatine.*

Make up the following solution. (No. I.)

Gelatine . . . . .	50 grams
(cut up into small pieces)	
Water . . . . .	300 c.c.

Place in a flask. Plug flask, heat until gelatine is dissolved.

In another flask make up the following mixture (No II):

Peptone . . . . .	6 grams
Dextrose . . . . .	5 grams
Common Salt (NaCl) . . . . .	1 gram
*Flesh extract . . . . .	20 c.c.
Water . . . . .	180 c.c.

Dissolve the mixture, and heat until solution has taken place.

Pour No. II into No. I. Neutralise with Sodium Carbonate. Use a very strong solution of Sodium Carbonate and keep adding it drop by drop under constant stirring until a piece of red litmus paper put into it just turns blue without becoming a pronounced blue. Place in steam steriliser for 20 minutes. Next allow the mixture to cool to

---

\* *Flesh extract*—Weigh contents of a *Lemco* jar, then add 5 c.c. water for every gram in weight. Suppose the weight of the paste is 30 grams. Dissolve in water and make up volume of paste and water to 150 c.c. Once dissolved the extract must be kept sterile otherwise it will go bad very quickly.

60° C., and then add the beaten white of an egg, shake well and place again in the steam steriliser until complete coagulation has taken place and the liquid looks clear.

Set up a filter on a stand, insert a filter paper in it, and with a pin make a hole at the bottom of the filter paper. Then fill the filter with cotton-wool. Pour the curdled mixture into the cotton-wool, after having put a beaker under the filter. The liquid goes rapidly through on account of the pin hole that has been made, but all the coagulated part is caught in the cotton-wool. The mixture is now ready for use. Sterilise for  $\frac{1}{2}$  hour in steam-steriliser, and for the next 2 days sterilise for  $\frac{1}{2}$  hour each day.

*Note on Gelatine.* Gelatine is an animal protein which is derived from various tissues, fibres, bones, cartilage etc. [In the animal tissues it exists not as gelatine but as the albuminoid *collagen*, and it is derived from this substance by hydrolysis.]

Some knowledge of the properties of gelatine is very necessary when dealing with the preservation of gelatine-containing media, for if it be heated too much the gelatine refuses to set: on the other hand, too little heating causes it to go bad because the germs in the gelatine have not all been destroyed. Gelatine will not set if subjected to prolonged heating. The more it is heated the lower becomes the melting point, and the final result of such a procedure is to lower the melting point below the temperature of the room. In consequence the medium remains permanently liquid. It has been stated that every hour's heating at 100° C. lowers the melting point of gelatine by 2° C. Experience does not bear out the magnitude of the amount of lowering given in this statement, but the lowering does take place at a comparatively rapid rate of progression. It is therefore a golden rule to avoid any unnecessary heating of gelatine, and to consider just how much is necessary for the purpose, and not go beyond that amount. For example, if 6 tubes of gelatine are needed (roughly about 60 c.c. of gelatine) and if the stock nutrient-gelatine contains say 500 c.c., then,

(500—60) = 440 c.c. have been melted to no purpose. When the next 6 tubes are required (440—60) = 380 c.c. have been melted twice to no purpose. It is therefore advisable to store the gelatine in small flasks containing 50 c.c.—100 c.c., and thus save the unnecessary melting. Further, small quantities require less time for complete melting than do larger quantities.

### Exercise 2. *Preparation of Nutrient-Broth.*

The mixture is made up from the following ingredients:

Peptone . . . . .	6 grams
Common Salt . . . . .	1 gram
*Flesh Extract . . . . .	12½ c.c.
Water . . . . .	480 c.c.

Neutralise as in Ex. I, filter through filter-paper, and place in steam-steriliser.

*Note on the Storage of Nutrient Broth.* Liquid media go bad much more quickly than do those solidified by the addition of gelatine or agar. When once properly sterilised infection can only take place by way of the cotton-wool plug. Attention must therefore be directed towards making this secure.

1. It must be tight-fitting.
2. It must be dry.

It is a good plan after the completion of the sterilisation, to substitute the plug of the flask containing the broth with another which has been sterilised in the hot-air oven, taking care to make a tight fit of it. Care must also be taken to prevent the mouth of the flask becoming wet when the plug is put in. If some of the broth is poured out, sterilise and dry the mouth of the flask by passing it through the flame before putting in the plug. Also pass the plug through the flame before fitting it into the flask. Do not store broth media in a damp room. If the broth is not wanted for immediate use, melted paraffin wax should be poured on the

---

\* See Exercise 1.

plug, after it has been cut down to the level of the top of the flask: then the mouth should be covered by a piece of paper soaked in melted paraffin wax. This should be tied by a piece of string round the neck of the flask.

### Exercise 3. *Preparation of Nutrient-Agar.*

Cut 8 grammes of agar into small pieces (or weigh out the same amount of agar powder), add 300 c.c. water, plug with cotton wool and place in steam steriliser till agar is dissolved.

In another flask put together the following mixture:

Peptone . . . . .	6 grams
Common Salt . . . . .	1 gram
* Flesh Extract . . . . .	20 c.c.
Water . . . . .	180 c.c.
Place in steam steriliser for $\frac{1}{2}$ hour.	

Mix two solutions, and make alkaline by adding a few drops of a very strong solution of sodium carbonate. Plug flask and leave in steam steriliser for  $\frac{1}{4}$  hour.

Filter in the same way as is recommended for the gelatine-medium in Exercise I.

*Note on Agar.* This substance is prepared from various seaweeds that are found in China and Japan. Unlike gelatine, it contains no nitrogen and belongs to the class of carbohydrates. It has the great advantage over gelatine that it remains solid at a much higher temperature and consequently bacteria can be cultivated at 37° C. and even at still higher temperatures, without the agar suffering any melting.

The melting point of a 1.5% neutral agar solution is 97° C., and its solidifying point 40° C. For bacteriological purposes a form of agar is preferable which melts above but not very far from 37° C., as nutrient agar is heated above this point only when it is desired to melt it, and the lower the melting point the less the danger the bacteria enclosed in the agar will run of having their vitality affected by heat. The agar must not remain fluid at 37° C., for that would

\* See Exercise 2.

prevent its use in the cultivation of a good many important species of bacteria.

In the preparation of nutrient media with agar as a constituent, the conditions affecting its solubility must be taken into consideration on account of its slow solubility and viscosity. The following facts must therefore be grasped before preparing agar-containing media.

1. The solubility of the agar is considerably affected when its proportion goes far above  $1\frac{1}{2}$  per cent. Fortunately this amount is ample for bacteriological purposes.
2. If the agar is dissolved in a fluid with an acidity equivalent to 0.1% HCl, the solution takes place readily but not so the subsequent solidification upon cooling. In a weak alkaline or neutral fluid, however, solidification takes place at about 40° C., and the product is pre-eminently suitable for bacteriological purposes.

When the solidifying power of agar is once destroyed by the presence of acid in excess it can never be regained, and the medium is useless for the cultivation of bacteria.

As in the case of gelatine-media, it is better to store agar-media in a number of small flasks rather than in one large one.

#### Exercise 4. *The washing and sterilisation of test-tubes.*

If the test-tubes are new, put them in boiling or hot water which has been made very slightly acid with HCl.\*

Clean with a brush.

Rinse under the tap.

Dry thoroughly.

Plug with cotton-wool.

Sterilise by placing in hot-air oven, until tubes have been exposed to a temperature of 140° C. — 150° C. for about

---

\* New test-tubes always have a certain amount of alkali clinging to them, and acid must be used to neutralise the alkalinity.

20 minutes. The value of cotton-wool as a plug is greatly impaired if the temperature is raised much above  $150^{\circ}$  C. for it turns brown and the fibres lose their power of cohesion.

Store tubes in some covered receptacle until they are required. A cigar-box, tea-caddy, cocoa-tin or tobacco-box will serve very well for storing the tubes.

If the test-tubes have been used before, wash them in water containing a pinch of washing-soda, cleaning each one with a test-tube brush.

*Note on the making of cotton-wool plugs.* There are many ways of making efficient plugs with cotton-wool. The part of the plug which is to be inserted inside the test-tube must be *roughly cylindrical*, as it has to be fitted into a cylindrical space viz. the top of the test-tube or flask. Care must therefore be taken to avoid a *conically* shaped plug. Again the part outside the tube must be large enough to admit of being easily grasped so that the plug may be taken out of the tube and replaced without any difficulty: but it should not be an ungainly mass. If the *insertion-part* of the plug is not cylindrical to begin with, some awkwardness will result when an attempt is made to replace it in the tube after it has been taken out. Finally the cylinder-plug must be just a trifle bigger than the space into which it is to be inserted, to enable it to be squeezed in and fit the space with a certain amount of firmness. It must not be too loose nor too tight.

Exercise 5. *Method of transferring nutrient media into tubes.*

Melt one of the small flasks containing nutrient-agar and one containing nutrient-gelatine. Pour the melted material into sterilised test-tubes putting roughly 10 c.c. in each. Prepare in this way 12 tubes containing nutrient-agar, and 12 containing nutrient-gelatine. Place the tubes in the steam steriliser for  $\frac{1}{2}$  hour.

After sterilisation, place the gelatine-tubes in an upright position, allow them to cool, and put them away in a covered receptacle. The agar-tubes must, however, be cooled in an oblique position (See Fig. 10). The reason for this will

appear later. Store the agar-tubes in an upright position in a covered box.

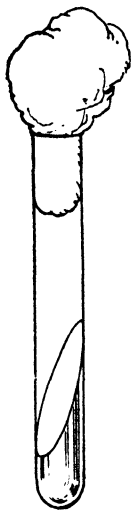

Fig. 10. — Agar-slope tube. Agar is allowed to set as shown in figure. This gives a larger surface on which the bacteria can grow than if the Agar were set horizontally.

If the tubes are not to be used for some time, the plug should be pressed deep down, and cut level with the top of the test-tube. Then some melted paraffin-wax should be poured on the plug.

*Note on the Selection of Mode of Sterilisation.* Sterilise any instrument or apparatus that will stand the naked flame without injury by passing it through the bunsen flame. Unfortunately the number of objects in use in bacteriological laboratories which are not injuriously affected is very small, and is confined to certain metallic objects e. g. Platinum needles, the blades of knives, and similar instruments. Also, the surface of a cotton-wool plug may be cleared of germs by dashing it through the flame. The plug is ignited but the flame can be easily blown out.

The next best method is by using the hot-air oven. Sterilise by dry heat everything that will not suffer injury by the process e. g. cotton-wool, all glass-ware, and metal receptacles. The temperature should be allowed to go up to  $140^{\circ}$  C.— $150^{\circ}$  C., and another 20 minutes allowed. Then put the gas out and allow the objects to cool inside the oven.

All nutrient-media, water, etc. must be sterilised in the steam-steriliser. One sterilisation is not enough for as the temperature at ordinary pressure is never above  $100^{\circ}$  C., many bacteria are not killed by this comparatively low heat and so sterilisation has not been achieved. It must be borne in mind that many bacteria exist in two forms, viz. as *spores* and as *vegetative cells*. A bacterial organism in its active condition, when it takes in food, grows, divides, excretes etc. is a thin-walled cell, the commonest type being the *Bacillus*, that shown in Fig. 11. This may be called a *vegetative cell*

It does not always, however, exist in this form, for inside the vegetative cells, reproductive cells are formed—usually one in each cell—which are called *spores*. (See Fig. 12). The vegetative cells die but the spores remain, and they are difficult to kill. Not every vegetative cell forms a spore, and in many species, probably the majority, spores are not formed at all. All vegetative cells are killed off, when a fluid is placed for a short time in the steam steriliser, but the exposure of a fluid for  $\frac{1}{2}$  hour to the action of steam is certainly not enough to kill off all the spores that may be present. The most resistant spores e. g. those of *Bac. subtilis* can stand

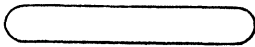

Fig. 11.—Shape of bacillus.



Fig. 12.—Showing a spore inside a vegetative cell.

6 hours continual immersion in steam without impairment of the power of germination. To cope with this difficulty the *Tyndall Method of Sterilisation* is usually put into practice. This method consists in subjecting the object to the action of the steam steriliser for  $\frac{1}{2}$  hour, which kills off all bacteria that are present in the *vegetative* form. Then a day is allowed to pass before the process is repeated. During the interval most of the spores, not killed by the first heating, will have germinated; this means that the spores have been transformed into vegetative cells. All such will be killed by the second  $\frac{1}{2}$  hour's heating to which the medium is now subjected. A third  $\frac{1}{2}$  hour's heating is supposed to account for the rest. It is still a somewhat controversial point whether the spores have actually germinated, and their progeny killed off, or whether this treatment has only weakened the spores. Whichever is correct, the result of this method of sterilisation is highly satisfactory. The following hints will be found useful.

1. In using the hot-air oven, any cotton-wool contained in it must not be allowed to come into contact with the sides, and especially the bottom, of the heated oven.
2. The floor of the hot-air oven should be covered with asbestos. Failing a supply of this substance care should

be taken to prevent glass or cotton-wool from lying on a surface the underside of which is exposed directly to the flame.

3. Bear in mind that cotton-wool becomes brown and brittle and useless when heated above  $160^{\circ}$  C. for any considerable time.
4. In using the Steam-Steriliser and Autoclave see that there is water inside the vessels, otherwise considerable damage may be done, when heat is applied.
5. After the completion of an experiment, place all that you have to clean in a pot of warm water, clean, dry, and put away. If working with organisms, the harmlessness of which is doubtful, boil the water for  $\frac{1}{2}$  hour before cleaning.
6. In passing the platinum needle (or loop) through the flame after using it for inoculation, take care that the material at the end of the needle does not roll up into a little ball and jump off on to the laboratory table, instead of being thoroughly charred at the end of the needle. This caution is particularly necessary when working with pathogenic organisms. To avoid this shedding of bacterial matter, the point of the needle must be placed in the hottest part of the bunsen flame. At the close of the exercise wash the table in the neighbourhood of the flame with thoroughness. It is better to rely upon removing dirt from the table than trying to kill the bacteria *in situ*. Thorough cleansing with hot water and soap is therefore strongly recommended. Sweep away the dirt and the bacteria will be swept away with it.
7. The oftener the walls, floors and tables receive a general cleaning, the fewer the chances of contamination.
8. If working with a pathogenic organism, it is not advisable to carry out exercises in the general laboratory. If possible, these organisms should be studied in a smaller room, and care should be taken beforehand that the room should be selected with a view to the ease with which a thorough cleansing can be given to it.

## CHAPTER III

Agar-plate culture: Agar-slope culture: Gelatine-plate culture:  
Gelatine stab culture: Gelatine shake culture: Broth culture.  
Revision.

### Exercises with a known organism.

For the next few exercises we shall work with a known organism. *Bac. megatherium*\* is a model organism for the beginner. The same exercises can, however, be made with any other organism, cultures of which are accessible to the student, but it is advisable to begin with a large, non-pathogenic, spore-forming bacillus.

#### Exercise 6. *To prepare Agar-plates.*

1. Place about 1 c.c. of sterile water in a small sterile tube.
2. Sterilise the Plat. loop, scrape with it the surface of the culture of *Bac. megatherium*, then transfer the scraping to the sterile water in the small tube.
3. Pass Plat. needle through flame.
4. Melt 3 Agar tubes. We will name these tubes respectively Nos 1, 2, 3.
5. Place on table 3 sterile Petri-dishes.
6. Lift Plat. loop, pass through flame, then remove 1 loopful from bacterial fluid in the small test-tube and transfer to No 1 melted Agar tube.

---

\* Cultures of this organism can be obtained by application to the Lister Institute, Chelsea, London, S.W.

7. Pass Plat. loop through flame, then remove 1 loopful from the infected No 1 Agar tube and transfer to No 2 melted Agar tube.
8. Pass Plat. loop through flame, then transfer in same way a loopful from No 2 to No 3 Agar tube.
9. Pass Plat. loop through flame and place on rest.
10. Transfer contents of No 1 Agar tube into Petri-dish, contents of No 2, into another Petri-dish, and contents of No 3 into the third Petri-dish.
11. Allow Agar to set, label Petri-dishes and put them in Incubator.

It is not possible to proceed further with this Exercise until the bacteria in each Petri-dish have developed into *colonies*.\*

Exercise 7. *To prepare an Agar-slope.*

1. Place 1 c.c. (approx.) of sterile water in a sterile plugged tube. Infect it with Bac. megatherium.
2. Pass Plat. loop through flame.
3. Dip it into infected water.
4. Spread the water on the loop over the surface of the Agar-slope. It is not necessary to penetrate the surface of the agar.
5. Pass Plat. loop through flame then lay it on the rest.
6. Place Agar-slope in Incubator.

Exercise 8. *To prepare Gelatine-plates.*

The Gelatine plate-cultures are prepared in precisely the same way as Agar-plates. See the description attached to Exercise 6, only for 'Agar' read 'Gelatine', and when

---

\* *Colony*. Each Petri-dish after the completion of this Exercise will contain a number of bacteria. These of course are not visible, but when each has formed a progeny of say 10,000, and these remain *in situ*, each group is visible to the naked eye as an oval or round or other shaped fleck in the Agar. Such a group is called a *colony*. If the colony is pure, all its members will be descended from the same individual.

finished, place the plates not in the Incubator but in a covered receptacle at room-temperature. (See Note 3.)

### Exercise 9. *Examination of the Agar-plate Cultures.*

We may assume that the Agar-plates now show *Colonies*. These must be examined carefully, and the results of the examination recorded as fully as possible in a notebook kept for the purpose. In addition make sketches of the colonies and of the appearance of the individuals under the microscope. The examination should be conducted in a systematic manner. The following order of investigation is recommended.

#### I. *Naked Eye Observations.*

1. The colour of the colonies.
2. The shape of the colonies.
3. The size of the colonies, and the time they have taken to attain this size.
4. The difference in shape—if any—between the colonies on the surface and those under the surface.
5. The texture of the colonies, whether a fleshy outgrowth from the surface of the Agar, or a thin outspreading layer, something similar to petroleum on water.
6. The preference of the organisms for spreading on the surface of, or throughout the substance of, the Agar.

II. *Hand-lens observations.* Confirm the results of the naked-eye observations.

III. *Examination with the microscope using a low-powered objective*, one for instance which gives the microscope a magnifying power of 40—60 diameters.

1. The *Outline* of the colonies. If *smooth*, whether thrown into undulations. Compare with the types shown in Fig. 13:

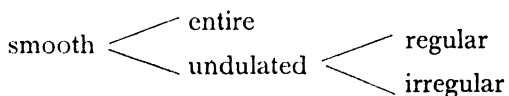

and ascertain whether the colonies conform to one or more of these types. If *rough*, whether roughness is due to projection from surface of numerous needle-like structures (Fig. 14 a) or due to their woolly consistency (Fig. 14 b).

- The *internal structure* of the colonies. Whether homogeneous, or granulated, or thrown into folds, or lumpy, or striped, or wrinkled.

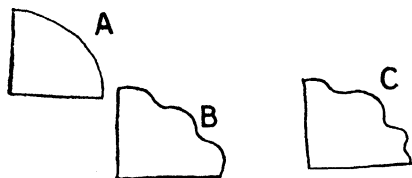

Fig. 13.—Outlines of Colonies.

- A—Entire.  
B—Undulated, regular.  
C—Undulated, irregular.

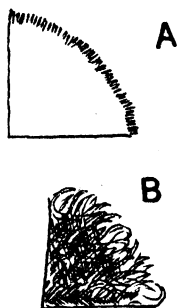

Fig. 14.—Outline of Colonies.

- A—Rough, needle like projections.  
B—Rough, woolly like projections.

#### IV. *Examination with high magnifying microscope* (magnification not-less than 350 diameters).

- Place a drop of water on a clean glass slide.
- Pass Platinum needle through flame.
- Open Petri-dish containing the colonies as much as is necessary to insert the Platinum needle inside.
- Insert Plat. needle inside Petri-dish and gently scrape one of the colonies with it.
- Place point of needle in drop of water on slide and thus transfer a little of the colony to the water. Transfer only as much to the drop as is necessary to make it very slightly turbid.
- Pass needle through flame and put on rest.
- Place coverslip on drop of water and examine under microscope.

Record in your note-books the answers to the following questions.

1. What is the shape of the individual organisms? Are they rod-shaped (*Bacillus* group) or spherical (*Coccus* group) or spiral (*Spirillum* group)?
2. Are the individuals separate, or are they joined together? If they are joined together, describe the mode of attachment. Are the individuals placed 'end on' like a string of sausages, or are they placed like soldiers drawn up in line?
3. Are they motile or non-motile? \*
4. Does the individual organism appear to be uniform in consistency, or can special structures be distinguished inside the cell?
5. Are there any *Spores* in the microscope-field?

[If any trouble is encountered in the identification of spores, the matter should be left in abeyance until the student has worked through later exercises.]

Further examination with the microscope should not in the meantime be carried on, pending some preliminary exercises in the art of staining.

#### Exercise 10. *Examination of the Agar-slope Culture.*

Examine the agar-slope when the culture is 24 hours old. There should be after this interval a distinct covering on the surface of the agar due to bacterial growth. Examine in the following order.

##### I. *External features of the bacterial growth.*

1. The *colour* of the covering.
2. The *texture* of the covering. Is it *fleshy* or *filmy*?
3. The *preference* for surface or for under-surface growth.
4. The presence or absence of fluorescence.

---

\* The student is warned that he is dealing with very minute organisms, so small that they often exhibit the so-called *Brownian or molecular movement*, a kind of trembling or shivering movement, and that he will need some practice before he can distinguish this movement from slow *independent motion* resulting from the lashing of the whip-like *cilia* with which the sides of many bacteria are beset.

II. *Examination under the microscope.* See Exercise 8. Section IV. The examination under the microscope should pursue the same general direction as in that exercise. Enter carefully your results in the Note-book, and make sketches to illustrate your results.

This culture should be examined after 2 days, 3 days, and after one week. The changes which take place as the culture gets older should be carefully noted especially in the matter of spore-formation and of motility.

Exercise 11. *Examination of the Gelatine-plate Cultures.*

These will take longer to develop than the agar-plates because the bacteria are growing at a lower temperature. When, however, the colonies have developed, the procedure is precisely the same as in the examination of the agar colonies (Exercise 9). In addition, the liquefaction or absence of liquefaction of the gelatine must be noted.

Exercise 12. *To prepare a Gelatine-stab.*

1. Place about 6 c.c. of sterile water in a small sterile plugged tube and infect it with *Bac. megatherium*.
2. Place on the table a Gelatine-tube which contains about two inches of nutrient gelatine.
3. Pass Plat. needle through flame, and hold in right hand.
4. Pick up tube containing sterile water, remove plug and dip needle to bottom of water.
5. Put down this tube and pick up Gelatine-tube with left hand.
6. Remove plug of Gelatine-tube as instructed in Note 2 of Appendix.
7. Stab the gelatine with the needle slowly and firmly right down to the bottom of the gelatine. It is particularly desirable that the needle should be taken out along the same path that it entered. Care must be taken also that the infected needle does not touch the sides of the tube on its way down the tube to the gelatine, and also when it is removed after infection.

8. Pass needle through flame and lay on rest.
9. Restore the plug to the gelatine-tube.
10. Put tube away in a cupboard.

[If the gelatine has become dry through long storage, it should be melted, a little sterile water added, and the gelatine again allowed to set. In any case care must be taken that the gelatine is not so dry that it does not close up *at once* after the infecting needle is taken out of it.]

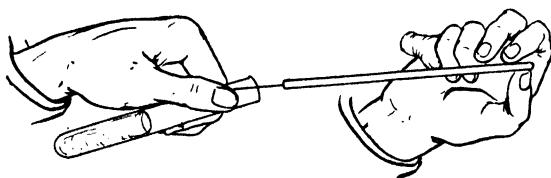

Fig. 15.—The tube is raised with the left hand and its plug withdrawn with the right hand and held between the palm and small finger of the right hand. The needle is lifted by, and operated with, the thumb and fore finger of the right hand.

### Exercise 13. *To prepare a Gelatine-shake.*

1. Melt a gelatine-tube.
2. Pass Plat.-loop through flame and hold in right hand. Then dip Plat.-loop into water infected with *Bac. megatherium*. [The material used for infection in Exercise 11 will serve the purpose.]
3. Pick up gelatine-tube with left hand, remove plug and infect the gelatine by dipping the loop into its substance. This must be done before the gelatine sets. The method of carrying out the infection is shown in Fig. 15.
4. Pass loop through flame and lay down on rest.
5. Place tube in cupboard and leave there for a few days.

### Exercise 14. *To prepare a Broth-culture.*

1. Take up Plat. loop pass through flame and once more dip into water infected with *Bac. megatherium*.

2. Pick up Broth-tube in left hand, remove plug and infect it with material taken up by Plat. loop.\*
3. Restore plug to broth-tube.
4. Pass Plat. needle through flame and lay on rest.
5. Place Broth in Incubator and examine after 1 day, 3 days, and one week.

Exercise 15. *Examination of Gelatine-stab Culture.*

Record results as follows.

1. Nature of liquefaction, if it takes place. Is it from above downwards, or does it start chiefly from the line of the Stab?

If liquefaction takes place, is there a sediment at bottom of liquefied gelatine? If so state its colour.

2. If liquefaction does not take place, is growth on surface, or is it chiefly under surface of gelatine? Is it a fleshy or filmy growth? What colour does it show?
3. Have bubbles of gas been formed in the substance of the gelatine?
4. *Examination of bacterial growth under microscope.*

Record on the following lines.

1. *Shape* of the organisms.
2. *Motility*. Note the presence or absence of movement among the individuals.
3. *Spores*. Record their presence or absence.
4. *Cohesion*. Are the individuals all separate, or are some joined together? If joined together, note how they are joined, and how many take part in the union.
5. *Cell contents*. Note any cell-structures inside the individual organisms.

Exercise 16. *Examination of Gelatine-shake Culture* (see Exercise 13).

The examination of the Shake-culture is conducted on exactly the same lines as is that of the Gelatine-stab.

---

\* See Fig. 15.

Exercise 17. *Examination of Broth Culture.*

Bacteria grow in broth cultures with greater rapidity than in solid media. Examine after 12—15 hours, after 2 days, after 3 days, after 1 week.

Investigate.

1. *The Reaction.* Find out with aid of litmus paper whether reaction is acid, alkaline, or neutral.
2. *Film-formation.* Has a thin covering formed on the surface? If so, what is its colour?
3. *Sediment* Has a sediment formed on the bottom of the tube?
4. *Coagulation.* Does the broth exhibit any coagulation as a result of the growth of the bacteria?

Examine under the microscope on following lines:

1. *Shape* of the organisms.
2. *Motility.* Whether motile, or non-motile.
3. *Spores.* Whether present or absent. If present, their relative abundance in relation to the vegetative cells.
4. *Cohesion.* Are the individual organisms free, or are some joined together? If joined together, how many on the average take part in the union?
5. *Cell contents*—Are any structures visible inside the cells, or do they show an unbroken uniformity?

*Revision.*

The exercises given in the preceding pages do not by any means complete all the observations that are possible in the investigation of any particular species of bacteria. They will serve, however, to illustrate the main lines which are employed in the diagnosis of bacteria. This diagnosis is based on the fact that whilst the majority of bacteria look very much alike under the microscope, they differ considerably in their physiological manifestations. The following facts should now be clearly grasped by the student before he proceeds to the later exercises.

1. The vast majority of bacteria are either spherical or rod-shaped or spiral.
2. Some species liquefy gelatine, others do not.
3. Some normally form *Spores* as resting cells, whilst others do not possess this capacity.
4. Some species show motility, whilst others have never been known except in the non-motile state.
5. Some grow best when oxygen is freely supplied to them, others only when oxygen is excluded.
6. Some species growing in broth give the latter an *acid* reaction, others make the broth *alkaline*, whilst a third group affects no change in reaction.
7. Some again form a skin on the surface of the broth, whilst others merely make the broth turbid.
8. Some *coagulate* a broth medium, others have not this capacity.

If we turn for a moment to the results obtained by the study of *Bac. megatherium*, we find that:

1. It is *rod-shaped*.
2. It *liquefies* gelatine.
3. It forms *gas* in gelatine.
4. It normally forms *Spores*.
5. It is *motile*.
6. It is *aerobic*.
7. It renders broth *very slightly alkaline*.
8. It forms a *skin* on the surface of the broth culture.
9. It does not coagulate the broth medium.

Here we have therefore a combination of well defined characters which should be sufficient for the identification of *Bac. megatherium*. If the preceding exercises are reviewed it will be found that our information was obtained from the results of making the following cultures.

- |                     |   |
|---------------------|---|
| 1. Agar plates.     | } |
| 2. Gelatine plates. |   |
| 3. Gelatine stab.   |   |
| 4. Gelatine shake.  |   |
| 5. Broth.           |   |

The student should now be in a position to set up all these cultures simultaneously. He will need 6 Petri-dishes, 5 gelatine tubes, 3 agar-tubes, small sterile tube containing sterile-water, and a broth-tube.

He must, however, bear in mind, that the process of identification is not so easy for all species, for the following reasons.

1. The organism may require a special medium in which to grow, and when growth has taken place the rate of growth may be very slow.
2. The organism may not exhibit its normal character, thus a spore-forming organism does not always form spores, neither is a motile organism always in a state of motility.
3. A change of character may accompany a difference in the temperature of incubation, thus an organism may form a blood-red covering on an Agar-slope at one temperature, but a grey one at another temperature.
4. The diagnosis of bacteria is still in the pioneer stage, and there can be little doubt that some organisms as for example *Bac. subtilis* must have been described under many different names.

In view therefore of the uncertainty which is always engendered in the mind of the bacteriologist by the enormous capacity for variation which bacteria possess, the student is advised to take a birds-eye view of his results and regard only the *sum-total* of the characters that his cultivations have brought to light. A few more of the difficulties will be discussed after we have concluded the exercises that are to be dealt with in the next section.

## CHAPTER IV.

The Staining of Bacteria. Use of Aniline dyes. Preparation of Stains. Dry-film staining. Wet Staining. Irrigation dry-film method. Hanging-drop preparation.

### The use of Aniline dyes in staining Bacteria.

Some forty years ago the discovery was made that bacteria took up certain dyes with avidity. It was found that all the basic aniline dyes such as fuchsine, methylene blue, methyl violet, gentian-violet and Bismarck brown readily stained bacteria, but that, on the other hand, the acid aniline dyes and the natural dye materials had not this power.

Next, the staining power of the dyes was found to be considerably enhanced by being mixed with a certain class of mordants, which seem to have the power of adhesion both to the bacteria and to the dye. Such are phenol, aniline oil, tannin etc.

The stains in actual use should be prepared from stock solutions of the dyes, for the staining capacity of most of them does not last very long when made up with water. Hence it is usual to prepare a stock solution by adding the dye to alcohol until the latter is saturated and cannot hold any more without precipitation. The majority of the stains used in Bacteriology are made up of a dilute alcoholic solution or of a solution of a basic aniline dye that is partly alcoholic and partly aqueous: and in most a mordant is also added.

Methylene blue is an exception to the rule that the aqueous solutions of bacteriological stains have no keeping capacity, for when made from this dye, solutions keep indefinitely.

In the following pages a *Stock solution* of a dye, unless otherwise stated, consists of a saturated solution of the dye in 90—100 % alcohol.

Exercise 18. *Preparation of Stains.*

(a) *Aniline Gentian Violet* (Ehrlich).

1. Stock solution 1.1 c.c.

2. Aniline saturated aqueous solution 10 c.c. Prepare this by shaking 5 c.c. of colourless aniline with 100 c.c. of water. Allow mixture to stand for some hours then filter through wet filter-paper.

[Is not dependable after 3 or 4 weeks.]

(b) *Methylene-blue* (1:40).

- |                             |         |
|-----------------------------|---------|
| 1. Stock solution . . . . . | 1 c.c.  |
| 2. Water . . . . .          | 40 c.c. |

(c) *Methylene-blue* (1:10).

- |                             |         |
|-----------------------------|---------|
| 1. Stock solution . . . . . | 1 c.c.  |
| 2. Water . . . . .          | 10 c.c. |

(d) *Fuch sine*.

- |                             |         |
|-----------------------------|---------|
| 1. Stock solution . . . . . | 2 c.c.  |
| 2. Water . . . . .          | 10 c.c. |
| 3. Alcohol . . . . .        | 10 c.c. |

(e) *Löffler's methylene-blue*.

- |   |          |
|---|----------|
| 1. Stock solution methylene-blue . . . . .      | 30 c.c.  |
| 2. Caustic potash solution (1:10.000) . . . . . | 100 c.c. |

(f) *Iodine*.

- |                         |          |
|-------------------------|----------|
| 1. Iodine . . . . .     | 1 gram   |
| 2. Pot-Iodide . . . . . | 2 grams  |
| 3. Water . . . . .      | 300 c.c. |

**The Art of Staining Bacteria.**

Two objects must be held in view: —

1. To obtain a white background. The organisms under examination should be the only stained objects in the field of view.

2. To give to the organism just as much colour as is necessary to bring out the different parts of its structure. An overstained organism presents one tone of colour and nothing can be made out of its contents, membrane etc.

To gain the first of these two objects, the bacterial material must be taken from a solid and not from a liquid culture. Further, when lifting the material from the culture, care must be taken that none of the agar or gelatine is removed at the same time.

The second of these aims can be gained only by constant practice. If the organism under observation is very small, the question of differentiation of structures does not come into play, for very minute bacteria under the best conditions of staining do not show any differentiation.

#### Exercise 19. *Dry-film Staining.*

Use for preference a young (15—24 hours old) culture of *Bac. megatherium* on an Agar-slope, or a colony of the same organism on a Gelatine—or Agar—plate.

1. Place on table a *clean* glass slide and put on it a small drop of clean water.
2. Pick up Plat. needle and pass through flame.
3. With needle remove a little of the culture and rub needle in drop of water *until the drop is very faintly turbid.*
4. Remove surplus material from needle by passing it through flame.
5. Pick up glass slide and spread out the drop over the surface of the slide with the needle. If the drop refuses to spread, do not go on but start again with a cleaner slide. Keep rubbing the drop over the surface of the glass until all the water has evaporated.
6. Fix by passing through flame once or twice. The hand carrying the glass slide should be moving at the rate of approximately one foot per second.
7. Lay slide on top of tumbler (Fig. 16) or clutch it with a pair of pincers.

8. Cover the dry film with Löffler's methylene blue for two minutes.
9. Pour off the stain by putting slide under tap and allowing a gentle stream of water to flow over it.
10. Put coverslip on, after removing all superfluous water, and examine under microscope.

If the preparation is satisfactory, allow the slide to dry, put a drop of Canada-balsam over the film, and a coverslip over the Canada-balsam.

The student should also prepare dry films and colour them with the other stains at his disposal.

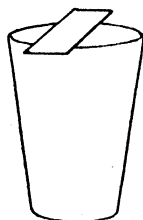

Fig. 16.

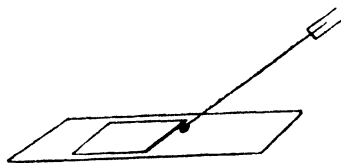

Fig. 17.—Showing position of loop when used to impart stain to liquid under coverslip.

### Exercise 20. *Wet staining.*

In the staining of bacteria the best results are undoubtedly obtained by colouring the bacteria with a dye which does not *immediately* kill the organisms. The object is to bring out contrasts between the different components of the cell and this is better effected whilst the organism is still living. The writer finds Iodine by far the most efficient stain for this purpose.

Nos 1., 2., 3., 4. are the same as in Exercise 19.

5. Cover drop with clean coverslip.
6. Pick up Plat. loop, dip it in Iodine solution (see Ex. 18) and then insert the loop on the right hand edge of the coverslip in such a way that the stain on the loop comes into contact with the bacterial fluid between slide and coverslip (See Fig. 17). The

Iodine slowly penetrates the liquid staining the bacteria which it encounters in its path. Several loopfuls of stain will probably be necessary to accomplish a satisfactory inflow of the stain. Whilst the stain is flowing in, the eye should be focussed through the microscope on bacteria that are on the verge of coming under the influence of the stain. Particular bacteria should be selected and these should be kept continuously under observation, and the changes which are effected in them during the course of the absorption of the dye carefully observed.

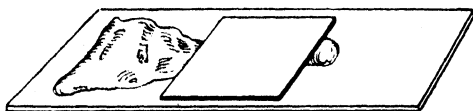

Fig. 17a.—To demonstrate irrigation method of staining. A drop of the stain is placed on the edge of the coverslip on the right side, and this is drawn through by a piece of blotting- or filter-paper placed on the edge of the coverslip on the left side.

If the stain moves too slowly put in a little more, and gently withdraw a little of the liquid from the left side of the coverslip with the aid of a small piece of filter paper (Fig. 17).

It must be kept in mind that the bacteria are not fixed to the glass and that consequently the inflow of the stain must not be made so rapid that the bacteria themselves are put into motion.

As *Bac. megatherium* contains globules of volutin which are stained by methylene blue, and also oily globules which do not take up this stain, this method should also be tried with methylene blue.

#### Exercise 21. *The Irrigation Dry-film method.*

The writer has found the following very useful.

Nos 1., 2., 3., 4., 5. are the same as in Exercise 19, with this difference that the film is prepared on the coverslip not on the glass slide.

6. On glass-slide lay down two parallel strips of candle grease. [Small candles used for decorating Xmas Trees serve the purpose admirably.] As their purpose is to raise the coverslip a little higher in order to obtain more room between coverslip and glass slide, the distance between the two strips must be made a trifle less than the length of side of coverslip (See Fig. 18).
7. Rest coverslip, film side downwards, on the two strips of candle grease.
8. Run water between coverslip and slide.
9. Place slide on microscope-table and focus on film. Select a good specimen and place it in centre of field. Observe its size before staining.

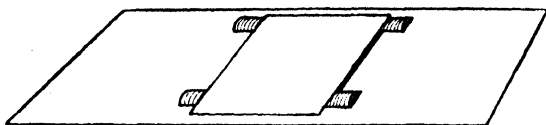

Fig. 18.—To demonstrate another irrigation method of staining. The coverslip is raised by putting down two parallel smears of candle-grease on the slide.

10. On right edge of coverslip, place a drop of gentian-violet and let it come in contact with the water under the coverslip.

The further procedure is the same as in the method described in Exercise 20 and figured in Fig. 17 a, with this advantage, however, that irrigation is easier to accomplish because the coverslip has been raised by the two strips of candle grease.

11. Remove blotting-paper and examine the organism selected for observation. How has the stain affected its size? Does any differentiation appear in the substance of the cell contents?
12. The stain may now be removed in the same way.

Insert blotting paper as before on left side of coverslip, and on the right place a drop of 70%—90% alcohol. When this is sucked in, add another, then another and so establish a flow of alcohol through the

space between coverslip and slide. Keep doing this until the alcohol has removed all stain from the organism.

In same way replace alcohol with water.  
Examine under microscope.

Still using the same individual organism that was kept under observation whilst using gentian-violet, we can in the same way see the effect of some other stain, say carbol-fuchsin.

Irrigate with carbol-fuchsin, clear carbol-fuchsin with water. See whether the same organism stained with gentian-violet has the same dimensions as when stained with carbol-fuchsin.

#### Exercise 22. *Hanging Drop Preparation.*

For this Exercise use a 24-hours Agar-slope culture of *Bac. megatherium*.

1. Place a small drop of water on a clean coverslip.
2. Pick up needle and pass through flame.
3. Remove with needle a small portion from surface of Agar-slope.
4. Rub end of needle in drop of water until latter is *very slightly* turbid.
5. Sterilise needle and lay on rest.
6. Place on table a glass slide of kind shown in Fig. 19.
7. Cover this shallow depression on slide with coverslip taking care that drop is on the under side.



Fig. 19. — Slide with shallow depression.

The coverslip can be smeared round the edges with candle grease. The air in the shallow depression suffices to supply the bacteria with as much oxygen as they require.

An ordinary slide, without the shallow hole, suffices for all observations of bacteria in water, which are not intended to be protracted for any length of time.

Exercise 23. *Gram Method of Staining.*

1. Prepare dry film on coverslip as indicated in Exercise 19, using a young culture (1 day old) of *Bac. megatherium*.
2. Stain with anilin-gentian-violet\* for 5 minutes.
3. Drain off the stain but do not wash the slide.
4. Immerse in *Io din* solution made up as follows:—
 

Iodine . . . . .	1 gram	}
Potassium Iodide . . . . .	2 grams	
Water . . . . .	300 c.c.	

 for 1—2 minutes.
5. Wash in alcohol until no more colour comes away.
6. Wash with water.
7. Examine under microscope.

Gram's method is a test of decoloration, for some species survive the treatment and still retain their colour, others have no vestige of colour after the treatment. It is advisable to attempt this method only with young cultures, for the results are very irregular in old cultures.

---

\* See Exercise 18.

## CHAPTER V.

Identification and Staining of Spores. Staining of cilia.  
Germination of Spores. Capsule staining. Contact  
preparation.

### Identification and Staining of Spores.

The student is advised to make sure that he can recognize a spore when he sees one under the microscope. Small highly refractive objects like oil-globules and minute foreign objects in the microscope field often look very like spores.

#### Exercise 24. *Identification of Spores.*

1. Put a small drop of water on a clean slide.
2. Remove a tiny portion from the surface of a 7-days old Agar-slope culture of *Bac. megatherium* with the end of a sterilised Platinum needle.
3. Rub the end of the needle in the drop of water until the drop is *very slightly* turbid.
4. Sterilise Platinum needle and place on rest.
5. Place coverslip on drop.
6. Examine under microscope, using highest magnification which is available.

The spores will be found either inside the vegetative cells or floating free. For the same species they will all be found to be have the same dimensions and the same shape. They are either round or more commonly slightly oval. They have a high refractive index which gives them a sparkling appearance. This feature is not confined to spores, for the same is true of oil globules and other cell contents. There will, however, be no other bodies in the microscope-field which are uniform both in shape and size. It is re-

commended that the spores be not examined under a magnification of less than 350—400 diameters.

A few drawings of various types of spores are shown in Fig. 20.

Exercise 25. *Staining of Spores.* Method I.

1. Place a small drop of water on a *clean* coverslip.
2. Infect it with material from a 7-days old Agar-slope culture of *Bac. megatherium* by means of Plat. needle (or loop). Drop must be made *very slightly* turbid.

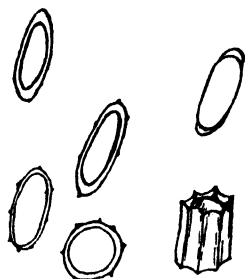

Fig. 20. — Spores.  $\times 6000$ .

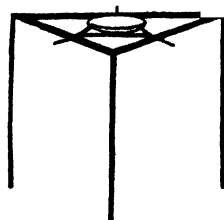

Fig. 21. — Watchglass supported by pipe-clay triangle on tripod stand.

3. Clean Plat. needle by passing through flame, then use it to spread infected drop over surface of coverslip. If the liquid balls up and will not spread, begin again on a cleaner coverslip.
4. Keep drawing the drop backwards and forwards over surface of coverslip until it has completely dried.
5. Fix slide by passing through flame once or twice. (Rate of movement about 1 foot per sec.)
6. Pour Gram Iodine Stain on coverslip and allow to remain 1—3 minutes.
7. Wash in alcohol.
8. Wash with water.
9. Apply hot carbol-fuchsin for one minute. Proceed as follows.
  - (a) Place watch-glass on a tripod stand supported as shown in Fig. 21.

- (b) Pour Carbol-fuchsin on watch-glass.
  - (c) Apply burner with tiny flame underneath watch-glass.
  - (d) When Carbol-fuchsin is slightly warm, drop coverslip carefully film side downwards on surface of hot fluid so that coverslip floats on its surface.
10. Dip just for a moment in 20 %  $H_2SO_4$ , and transfer at once to water.
  11. Counterstain by putting a few drops of a methylene-blue stain on coverslip and allowing the stain to act for a few seconds.
  12. Wash in water and examine with an oil-immersion lens, or failing the possession of one, the highest magnification available.

The Spore has two walls, the outer a thick tough one usually with markings or small projections on the outside, the inner a thin delicate membrane, which cannot be seen except in excellently prepared material viewed with the highest magnifications.

See Fig. 20.

#### Exercise 26. *Staining of Spores.* Method II.

Nos 1., 2., 3., 4., 5. same as for preceding exercise.

6. Stain in warm Carbol-fuchsin for 10—20 minutes.  
(See No 9 of preceding exercise.)
7. Wash in water.
8. Decolorise for a few seconds by dipping in 3 % alcoholic solution of hydrochloric acid.
  - 3 c.c. alcohol.
  - 97 c.c. hydrochloric acid.
9. Wash in water.
10. Counterstain with Löffler's Methylene Blue for 3 minutes.
11. Wash in water.
12. Dry, and mount in Canada Balsam: the spores are *red*, the background *blue*.

Exercise 27. *Staining of Spores.* Method III.

- Nos. 1, 2, 3, 4, 5, same as in Exercise 25.
6. Place coverslip in Absolute Alcohol for 2 minutes.
  7. Place in chloroform for 2 minutes.
  8. Wash thoroughly and then place in 5% Chromic Acid for one minute.
  9. Wash thoroughly in water.
  10. Stain in warm Carbol-fuchsin for 10 minutes. (See Exercise 25, No. 9).
  11. Decolorise in 1% Sulphuric Acid for a few seconds.

*The Staining of Cilia (Flagella).*

Bacteria possess organs of motion in the form of relatively long whip-like filaments of living matter called *Cilia* by some *Flagella* by others. They pass through the external membrane from the inside and extend into the surrounding fluid. In some species the cilia are found distributed all over the organism, in others they are confined to the poles. See Fig. 22.

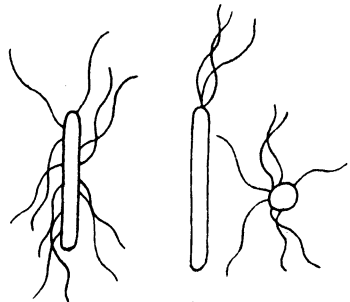

Without staining they are not visible even when the bacteria are observed with the highest powers of the microscope: neither are they rendered visible by treatment of the bacteria with stains in the usual way. To render them visible great care must be exercised for the following reasons.

1. If they are stained too intensely they swell up and disintegrate: if they not sufficiently stained they are not visible.
2. Rapid changes of temperature, or high temperatures affect them deleteriously.
3. Rapid changes in concentration of the fluid also have an unfavorable effect.

Fig. 22. — Figure on left shows a Bacillus with its cilia distributed over every part: figure in middle shows a Pseudomonas with polar ciliation: figure on right shows a Coccus with distributed cilia.

The cilia of some bacteria are much more difficult to stain than those of others, and of the various kinds of bacteria, if possible a species of *Spirillum* should be first experimented with, for in this group the cilia are situated at the polar end of the organism and are usually bunched together.

Exercise 28. *The Staining of Cilia.*

1. Select if possible a *Spirillum* culture. Failing a culture of this kind, any fast moving bacillus will serve, e.g. *Bac. typhosus*.
2. Do not make the attempt unless the organism is actually in a motile condition. It must be borne in mind that cilia are not present during the whole of the life of the bacterial organism, They are not usually present when there is no movement, but they may be.
3. Do not make the attempt with a *liquid* culture. Select an Agar- or Gelatine-culture for the exercise.
4. Do not select an old culture.
5. Attention to the minutiae of the detailed instructions is all important for ensuring success.

Carry out the following procedure.

1. Clean a glass slide by scrubbing its surface with filter paper soaked in alcohol: after scrubbing, pass slide through flame several times.
2. Clean coverslip in the manner indicated in Note 7. Use for the purpose an unused coverslip in preference to one that has already seen service.
3. Test surface of coverslip with clean water to be certain that when the film is subsequently formed, the water will not 'ball up' instead of spreading to form the film. To this end dip needle in water and draw needle over surface of coverslip. If film forms properly, dry the coverslip and place it in forceps.
4. On glass slide place 3 small drops of water each one about 3 millimetres in diameter.
5. Pick up Plat. loop and sterilise, then with it, after it has cooled, remove a little material from an Agar-slope

culture. Add as much of this to one of the drops of water as is necessary to produce the faintest appearance of turbidity in the drop. We will call this drop No. 1.

6. Clean Plat. loop by heating it in bunsen-flame; allow it then to cool.
7. Transfer with the loop a little from drop No. 1 to one of the remaining drops (Drop No. 2).
8. Clean and cool Plat. loop as before.
9. Transfer a little from Drop No. 2 to Drop No. 3.
10. Lift up pincers holding the coverslip with left hand. With right hand take up Plat. loop and dip it into Drop No. 3.
11. With loop draw a film about 3 m.m. wide on coverslip parallel to one of the edges.

Take up another loopful from drop No. 3 and draw a film parallel to the first.

Take another loopful from Drop No. 2 and draw a third film.

The 3 films will now appear as shown in Fig. 23.

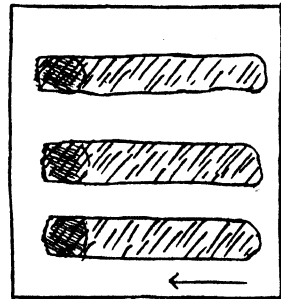

Fig. 23. — Coverslip with three parallel films. For further explanation see text.

12. Allow three films to dry at room-temperature.
13. Pour some of *Mc Crorie's night-blue\** stain on coverslip. Filter stain before dropping it on coverslip. Allow it to act for five minutes at room-temperature.
14. Wash in gently flowing water, dry at room-temperature.
15. Mount in xylol and examine under microscope.

\* *Mc Crorie's night-blue Stain:*

- |   |   |   |
|---|---|---|
| A | { | add 1 gram tannin to 20 c.c. hot water.       |
|   |   | add 1 gram potash-alum to 20 c.c. cold water. |
|   |   | mix.  |
| B | { | $\frac{1}{2}$ gram night-blue.                |
|   |   | 20 c.c. abs. alcohol.                         |

B must be added to A not A to B.

Filter. The liquid keeps for a long time.

The coverslip should show three slightly coloured films with clear uncoloured spaces between the films.

The films must be examined systematically for it very seldom happens that the bacteria are found beset with cilia in all parts of the film.

The action of the stain varies with different species and it will be found in practice that in some cases a little less time must be allowed, in others a little more, for the action of the stain.

### *The Germination of Spores.*

When spores become moistened, they shed their outer membrane, and the contents emerge and expand into the *vegetative* cell. The types of this germination for various species are shown in Fig. 24.

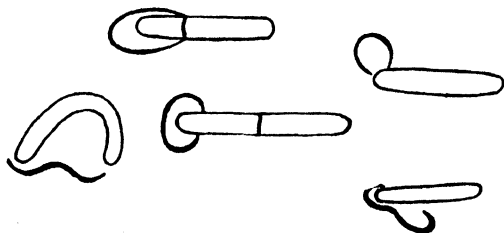

Fig. 24.—Types of Germination in the bacillus group. The spore-membrane is left behind as the inner part expands and assumes the vegetative form.

### Exercise 29. *Germination of Spores of Bac. Megatherium.*

1. Examine a week old Agar-slope culture of *Bac. megatherium* under microscope to see if it contains plenty of spores.
2. Take out a small sterilised test-tube and put in it one or two large drops of water.
3. Infect the water in this tube with as much material from the culture on the Agar-slope as it can take, until it almost becomes a paste.
4. Put the test-tube in boiling water for 2 minutes to kill off all vegetative cells that may happen to be present.
5. Pick up Plat. loop and sterilise.

6. With loop spread infected water over surface of an Agar-slope tube, taking care that the latter gets a very generous helping. The idea is to have as many spores as possible on the slope in order to increase the chances of successful germination on the part of some spores.
7. Put Plat. loop through flame and lay on rest.
8. Incubate for 6 hours at approximately 30° C.
9. Pick up Plat. loop and put through flame.
10. Scrape off from the Agar-slope a loopful of the material which was placed on it 6 hours previously, and mount in a drop of water on a glass slide.
11. Put down Plat. loop after sterilising\* it.
12. Examine spores.

In artificial cultures spore-germination takes place normally after 6 hours, but the process may be delayed under the influence of various factors. A large number will be seen to have lost the highly refractive appearance characteristic of spores. Amongst such some will show burst membranes whilst others will even show the vegetative cell protruding from the spore. Various stages in the germination of the spores can be readily followed. There is a certain amount of variety shown by the different species in the mode of germination. In some the vegetative cell emerges from the poles, in others from the equator. In some cases the vegetative cell may emerge at both poles in which case the spore membrane is usually split into two parts. It is not certain that any one particular species always adheres to one type of germination.

It is necessary to add much spore-material to the surface of the agar because if a few spores only are present a

---

\* From this point onwards no special instructions will be given with regard to the procedure that should be followed in the handling of the Platinum loop or needle. It must be emphasized that the student should automatically sterilise when he picks one or other of these up and just as automatically sterilise before laying the needle or loop down on the rest

small percentage of these would rapidly outstrip the others and swamp the field with their numerous progeny. It is only when there are very many spores that it is possible to see a fair number of spores all at approximately the same stage of germination. Again, if the vegetative cells were not killed before inoculation, they also would soon swamp the spores with the large numbers of vegetative cells which they would have produced by division.

### *Capsule Staining.*

It is not uncommon to find bacteria enclosed in an envelope of some clear substance which is difficult to stain. This envelope is called a *Capsule*. In liquid cultures of bacteria exhibiting this formation, the surface is covered by a capsular film just as water is covered with ice. A broth culture of *Bac. megatherium* supplies excellent material for the study of capsule formation.

#### Exercise 30. *Capsule Staining* (Muir's Method).

1. With needle or loop inoculate a broth-tube with *Bac. subtilis*. (See Exercise 13.)
2. Prepare and dry a film on a slide. (See Exercise 19.)
3. Wash slightly in alcohol then thoroughly in water.
4. Place for a few seconds in a mordant made up as follows:—
 

{	Sat. solution mercuric chloride . . .	2 parts
	20 % tannic acid solution . . .	2 „
	Sat. solution potash-alum. . . . .	5 „
5. Wash in water then place in methylated spirits for one minute.
6. Wash in water.
7. Counterstain with methylene-blue for 30 seconds. (See Exercise 25 and Note 6.)
8. Dehydrate with alcohol.
9. Clear with xylol.
10. Mount in Canada Balsam.

The bacteria should be *red* and the capsule *blue*.

**Exercise 31. *Contact Preparation.***

1. Select a fairly large colony in a Gelatine-plate culture of *Bac. megatherium*, which is at least a centimetre distant from any other colony on the same plate.
2. Lower a coverslip on top of it.
3. Press coverslip down very gently on colony with a pencil, or any other pointed article.
4. Lift up coverslip, without causing the slightest lateral movement on the part of the coverslip.
5. Dry, fix, and stain in usual way. (See Exercise 19.)

## CHAPTER VI.

Reserve food materials. Volutin, glycogen and oil-globules.  
Gas production. Acid production. Indol production.  
Milk cultures.

### Reserve Food Materials.

In the cells of bacteria the main reserve materials which can be easily identified by the use of reagents are Volutin, Glycogen and Oil.

*Volutin.* This name was given by Meyer to this particular reserve material because it was first found in *Spirillum volutans*\*. On account of the similarity with cytoplasm which volutin exhibits in its reaction to stains, and on account of other properties it is regarded as being of a *protein* nature.

Exercise 32. *To demonstrate presence of Volutin.*

1. Melt an Agar-slope and add 5 or 6 drops from a 10 % per cent. solution of dextrose.
2. Allow the Agar to set again as a slope.
3. In a small sterile tube, put in two or three drops of sterile water, infect it with material from a culture of *Bac. megatherium* which contains a plentiful supply of spores.
4. Place in boiling water for 2 minutes to kill off all the vegetative cells.
5. Inoculate the Agar-tube with this material, and incubate at 28° C. for two days.

---

\* This organism was not *Spir. volutans* but *Spir. giganteum*.

The bacteria forming this culture will contain an abundance of *Volutin*.

*Bac. alvei* is an organism which is easily available and likewise shows an abundant development of volutin.

Others are *Spirillum volutans* and *Bacillus asterosporus*.

Volutin stains a bright blue with methylene blue. The following procedure is recommended.

1. Take out a loopful of the culture.
2. Mix it with a drop of methylene-blue (1 + 10).
3. After 5 minutes take out a loopful from the drop and examine under microscope. The volutin globules stain deep blue, the rest of the cell being either very faintly stained or else not stained at all.

### *Glycogen.*

Glycogen is the carbohydrate reserve food of bacteria as it is of many other Fungi. Among the soil-bacteria its presence has been demonstrated in *Bac. carotarum*, *simplex*, *cohaerens*, *asterosporus*, *subtilis*. The writer has also found it in *Cladotrix dichotoma* among the Iron-bacteria.

Exercise 33. *To demonstrate presence of glycogen.*

1. Add a loopful of the culture which it is desired to test\*, to a drop of Iodine solution.
2. After 5 minutes take out a loopful from the drop and examine under microscope.

If glycogen is present it becomes stained a sherry-brown colour, the other components of the cell being much lighter in colour or not stained at all.

### *Oil Globules.*

In *Bac. megatherium* volutin globules are mixed with oil-globules, and it is not possible to distinguish one from

---

\* As *Bac. megatherium* is not suited for this exercise the student is advised to make his test on *Bac. subtilis*.

the other when the bacteria are examined in the unstained condition.

Exercise 34. *Staining of Fat globules (Meyer's Method).*

1. Subculture *Bac. megatherium* on an Agar-slope. After two days incubation at 30° C., remove a small portion of the culture, and examine in water to see if the cells contain roundish strongly refractive bodies. In the event of their presence proceed as follows.
2. Prepare the following stain.

{ Sudan III (amido-azo-benzol-azo-β-naphthol . . . . . 1 gram.  
 { 95 % alcohol . . . . . 20 c.c.

3. Place a drop of 35 % formaldehyde on a slide, and mix with it a loopful of the Agar-slope culture. Allow the formaldehyde to act for 5 minutes.
4. Add to the formaldehyde a drop of methylene blue and keep stirring the mixture with the loop for 10 minutes.
5. After this interval add to the mixture a loopful of an equal mixture of Sudan stain and water.
6. Examine under the microscope.

The cell plasm (cytoplasm) is *blue*, the fat globules are *red* and the cell membrane *weak red*.

Exercise 35. *To distinguish between Fat globules and Spores.*

1. Examine a three days old Agar-slope culture of *Bac. megatherium*. This should contain young spores, and in many of the cells fat globules will also be noticed.
2. Place a very little bacterial material from the top part of the culture in a drop of Chloralhydrate

Chloralhydrate . . . . . 5 grams  
 Water . . . . . 2 c.c.

and mix well with the Plat. loop.

The fat globules disappear while the spores remain as sharply defined as when placed in water.

*Gas Production by Bacteria.*

Gas production in the cultivation of Bacteria is a comparatively frequent phenomenon. As certain species under certain conditions of growth always produce gas, whilst others never do so, we can make use of gas production for purposes of diagnosis. Among the gases thus formed we find Carbonic Acid, Sulphuretted Hydrogen, Nitrogen, Hydrogen and Methane. Among these Carbonic Acid and Hydrogen are most commonly formed.

Exercise 36. *Preparation of solutions of various Carbohydrates and other gas-producing foods.*

Make 10% solution of each of the following, *glucose, lactose, cane sugar, glycerine, galactose, alcohol, mannite.*

for example  $\left\{ \begin{array}{l} 5 \text{ grams of glucose} \\ 50 \text{ c.c. water} \end{array} \right\} = 10\% \text{ glucose.}$

Keep in a drop-bottle, after sterilisation. Prepare 10% solution of each of the other substances in the same way, label each and store until required.

A good drop-bottle for holding these solutions is shown in Fig. 9 g.

Before storing it is advisable to find out the volume of the drops if this type of bottle be used. Therefore with the stopper in the open position allow the drop to fall into a graduated jar and note the number of drops necessary to make 1 c.c. This number is about 20:

Exercise 37. *Preparation of Agar-tubes for gas-testing.*

1. Place seven Agar-tubes each containing approximately 10 c.c. in a test-tube rack after having first melted the Agar.
2. In one allow 20 drops to fall from the 10% glucose bottle. In the next 20 drops from the 10% lactose bottle, and so on until each tube has received 20 drops from one or other of the 10% solutions prepared in the preceding exercise.

[Calculation. The bottles (Exercise 36) were made up of 50 c.c. water and 5 grams of (for example) glucose.

Hence 50 c.c. contain . . . 5 grams glucose

„ 1 c.c. contains . . .  $\frac{1}{10}$  gram „

„ 20 drops contain . . .  $\frac{1}{10}$  „ „

„ culture-tube receives  $\frac{1}{10}$  „ „

and as culture-tube contains approx. 10 c.c.]

Therefore culture tube contains 1% glucose.

Exercise 38. *Cultivation of bacteria in gas-producing media.*

1. Melt the seven culture-tubes prepared in preceding exercise.
2. Before they set again inoculate each with a loopful from a culture of any one of the following bacteria.
  - Bac. acidi lactici.
  - Bac. subtilis.
  - Bac. asterosporus.
  - Bac. coli communis.
  - Bac. kiliense.
  - Bac. vulgare.

3. Place in incubator (30° C.) and observe, after growth has taken place, whether any bubbles of gas are found in the substance of the culture medium.

All the bacteria mentioned above produce gas in glucose-media. Bac. megatherium gives a negative result in this exercise.

[If the organism selected for this exercise is known not to liquefy gelatine\*, more striking results are obtained in gelatine rather than in agar-media. The procedure is exactly the same as detailed in Exercise 37, only that seven gelatine tubes are used instead of seven containing the agar-medium.]

Exercise 39. *Gas-production in broth-cultures.*

1. Pour approximately 10 c.c. of broth into each of seven test-tubes.

---

\* Among non-pathogenic organisms that are gas-producers in a glucose-medium and also non-liquefiers of gelatine may be mentioned Bac. coli communis and Bac. kiliensi neither of which is difficult to obtain.

2. Into each pour 20 drops from one or other of the bottles containing the 10% solutions of various carbohydrates etc. (See Exercise 36.)  
Each broth-tube therefore will contain 1% of the added substance.
3. Into each broth-tube drop a small sterilised test-tube, mouth downwards, into the broth. These small test-tubes, used in this way are called *Durham's Fermentation Tubes*. One is shown in position in Fig. 9c. Care must be taken that the fermentation tube does not enclose air when it is placed inverted in the larger culture-tube.
4. Inoculate each tube with the organism under examination. (See Exercise 38 for choice of organism.)
5. Incubate at approximately 30° C. and note the result after growth. If gas is evolved a part of it collects in the tube and raises it up above the surface of the liquid.

Exercise 40. *Cultivation of a Gas-forming organism in Smith's Fermentation Tube.*

Having now ascertained (Exercises 38 and 39) that a certain bacterial organism produces gas, we may proceed to make a qualitative examination and also a rough estimation of the quantity of gas that is produced.

1. Fill a Smith Fermentation Tube (see Exercise 39) (Fig. 9c) with glucose-broth taking care that the longer arm is full to the top. This can be done by careful tilting.

[The bulb is plugged with cotton wool, but care must be taken that the space in the bulb between the cotton wool and the level of the liquid in the bulb is greater than the volume of the long arm.]

2. Sterilise.
3. Inoculate.
4. Incubate at approx. 30° C.  
[If *Bac. coli* is used, incubate at 37° C.]
5. Examine for gas-production after 24 hours. Mark the

extent to which the liquid in the long tube has been driven down by the gas, produced by the bacteria.

6. Fill the short arm with 10% NaOH, and close opening with the thumb. Shake vigorously. After the shaking a diminution in the volume of the gas in the long arm will be observed due to the absorption of that part of it which is made up of CO<sub>2</sub>.
7. Still keeping the opening closed with the thumb, transfer all the gas that remains in the long arm to the bulb. Set a light to this gas. The presence of hydrogen and probably methane will cause it to catch fire.

Other gases may be present but their detection requires more elaborate apparatus.

If after the gas has begun to be formed in the long tube, its volume is seen to decrease with further incubation, this may be taken as due to the absorption of CO<sub>2</sub> by the broth, for roughly speaking 1 volume of water dissolves 1 volume of CO<sub>2</sub>, whilst of the other gases likely to be present in any quantity,

1	volume	of	water	dissolves	only	0.019	vol.	H
1	"	"	"	"	"	0.059	"	CH <sub>4</sub>
1	"	"	"	"	"	0.014	"	N.

It will be observed that the gas production cannot be exactly measured by the employment of the Smith Fermentation Tube as some of it escapes through the cotton wool plug. It is possible, however, to obtain an approximate estimation.

### *Acid-production in Bacteria.*

Many species of bacteria decompose sugars with production of one or more acids, the commonest being acetic, butyric, lactic and oxalic acids. Thus some species decompose glucose with acid production, and among these some produce a greater amount of acid than others. Other species do not decompose this sugar at all. We can therefore make use of this diversity in relation to acid production for the diagnosis

of bacterial species. It is obvious that it will be possible only if we employ a standard broth containing a standard quantity of sugar. Further in all the experiments a fixed amount of the broth must be used and a time limit set to the period of incubation. Lastly the acidity must be calculated in terms of some selected acid e. g. sulphuric or hydrochloric acid.

*Standard Normal Solution.*

A standard normal solution is such that one litre of the solution contains the equivalent weight in grams of the substance under consideration.

NaOH molecular weight  $23 + 16 + 1 = 40$ , equivalent weight 40  
 $H_2SO_4$  " "  $2 + 32 + 64 = 98$ , " "  $\frac{98}{2}$   
 $= 49$

Hence a normal solution of NaOH will contain 40 grams of NaOH per litre, whilst the same solution for  $H_2SO_4$  will contain 49 grams of this substance. Made up in this way it will be found that for example 10 c.c. of normal NaOH will be neutralised by exactly 10 c.c. of normal  $H_2SO_4$  or 10 c.c. of any other normal acid solution.

Suppose we find that 100 c.c. broth culture develops an acidity that requires 5 c.c. of a normal solution of NaOH (written  $\frac{N}{1}$  NaOH) to neutralise it we proceed with our calculation as follows.

$$1000 \text{ c.c. } \frac{N}{1} \text{ NaOH} = 49 \text{ grams } H_2SO_4$$

$$1 \text{ c.c. } \frac{N}{1} \text{ NaOH} = .049 \text{ gram } H_2SO_4$$

$$5 \text{ c.c. } \frac{N}{1} \text{ NaOH} = .245 \text{ " } H_2SO_4.$$

Hence acidity = .245 %  $H_2SO_4$  as we started from 100 c.c. of broth culture.

The Student is advised to have in readiness standard solutions of  $\frac{N}{1}$ ,  $\frac{N}{10}$  and  $\frac{N}{20}$  HCl or H<sub>2</sub>SO<sub>4</sub>

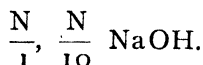

Exercise 41. *Development of acidity in broth culture.*

1. Prepare 100 c.c. of broth (Exercise 2) and add to it 2 grams of grape sugar.
2. Inoculate with Bac. megatherium, and incubate at 30° C. for 5 days.
3. Remove 10 c.c., and place in crucible.
4. Add a drop of phenolphthalein as indicator for titration.

Phenolphthalein . . . . .  $\frac{1}{2}$  gram  
50% alcohol . . . . . 100 c.c.

In an acid solution this substance is colourless; in an alkaline solution, red.

- 5 Add  $\frac{N}{10}$  NaOH drop by drop until the liquid becomes permanently pale pink in colour. Suppose 5 c.c. of  $\frac{N}{10}$  NaOH are found necessary to produce the pink colour. 10 c.c. of broth were neutralised by 5 c.c. of  $\frac{N}{10}$  NaOH.

Hence 100 c.c. of broth would require 50 c.c. of  $\frac{N}{10}$  NaOH

" 100 " " " " " 5 " "  $\frac{N}{1}$  NaOH.

If we calculate this in terms of H<sub>2</sub>SO<sub>4</sub> we can obtain the percentage as follows.

If 1000 c.c.  $\frac{N}{1}$  NaOH = 49 grams H<sub>2</sub>SO<sub>4</sub>

1 "  $\frac{N}{1}$  NaOH = .049 " H<sub>2</sub>SO<sub>4</sub>

5 "  $\frac{N}{1}$  NaOH = .245 " H<sub>2</sub>SO<sub>4</sub>.

Hence the acidity = .245% H<sub>2</sub>SO<sub>4</sub>.

If we calculate in terms of HCl we proceed as follows.

$$\text{If } 1000 \text{ c.c. } \frac{N}{1} \text{ NaOH} = 36.5 \text{ grams HCl}$$

$$1 \text{ " } \frac{N}{1} \text{ NaOH} = .0365 \text{ " HCl}$$

$$5 \text{ " } \frac{N}{1} \text{ NaOH} = .1825 \text{ " HCl}$$

Hence the acidity = .1825 % HCl.

### *Indol Production.*

Indol is one of the final products of protein decomposition and has the formula  $(C_6H_4(CH)_2NH)$ . It combines with nitrous acid to produce nitroso-indol nitrate, and as this latter substance has a red colour, its appearance in a fluid can be readily detected. The test for indol is consequently made by adding a little nitrous acid to a broth culture in which the presence of indol is suspected. The formation of a red tinge in the broth indicates a positive result.

#### Exercise 42. *Test for Indol.* Method I.

1. Inoculate a broth-tube with *Bac. megatherium* and another with *Bac. coli communis*.
2. Incubate 24 hours at  $37^\circ \text{C}$ .
3. Prepare Stock Solution as follows:

Water . . . . . 100 c.c.

Sodium nitrite . . . . . 5 grams.

Take 2 c.c. of Stock Solution and dilute it to 100 c.c.

4. Add approximately one c.c. of diluted nitrite-solution to every 10 c.c. of incubated broth solution.
5. Allow a little concentrated HCl to trickle down the side of the tube. The acid acts on the nitrite and nitrous acid is produced. The nitrous acid acts on indol—if present—under production of nitroso-indol nitrate.

The culture will consequently assume a red colour. If the colour does not immediately appear, place

the tube back in the incubator and examine again after  $\frac{1}{2}$  hour.

It will be found that Bac. megatherium gives a negative reaction, whilst the red colour develops in the Bac. coli tube.

Exercise 43. *Test for Indol.* Method II.

1. Same as in preceding Exercise.
2. Prepare the following *Stock-Solution*.
  - (a) Para-dimethyl-amido-benzaldehyde . . . . . 4 grams
  - (b) Absolute Alcohol . . . . . 380 c.c.
  - (c) Conc. HCl. . . . . 80 c.c.
3. Place 2 c.c. of this Stock-Solution in a test-tube and add to it 2 c.c. of the broth and 2 c.c. of Potassium persulphate.

The presence of Indol is indicated by the appearance of a rose-pink colour.

Bac. megatherium gives a negative, and Bac. coli a positive reaction.

### *Milk Cultures.*

If milk be sterilised, and different tubes of milk inoculated with various bacteria, the reaction of the milk will not always be the same. Some of the tubes will show an acid reaction, others an alkaline reaction, and a third class will exhibit neutrality. Further, some of the tubes will show curdled milk after incubation, others will be unchanged in this respect. We may therefore use milk cultures for purposes of diagnosis.

Exercise 44. *Milk Culture.*

1. Sterilise half a tube full of fresh milk by placing for  $\frac{1}{2}$  hour in the steam steriliser on each of 3 successive days.
2. Inoculate with Bac. megatherium.
3. Incubate at 30° C. for 3—4 days.
4. Place some blue litmus paper in the culture. Observe that the paper turns red, showing the presence of acid.
5. Observe also that the milk is coagulated.

## CHAPTER VII.

Anaerobic bacteria. Methods of plating and of cultivating anaerobic bacteria. Methods of estimating the size of bacteria and of other minute objects. Production of  $H_2S$ .  
Milk Cultures.

### Cultivation under anaerobic conditions.

The remarkable fact was discovered by Pasteur that there is a class of bacteria, the members of which not only prefer to grow in a medium from which all oxygen has been excluded, but are not able to grow at all unless oxygen has been rigorously excluded. It has since been discovered that if the oxygen be supplied to these organisms in an extremely dilute form, even the most rigorous *anaerobes*, as these organisms have been called, use up the oxygen. Some of them will not grow at all under ordinary atmospheric conditions (obligative anaerobes): others again prefer to grow without oxygen, but the presence of oxygen does not retard their growth (faculative anaerobes). We have seen that *Bac. megatherium* grows vigorously when plentifully supplied with oxygen and have now to find out whether its growth is equally vigorous under anaerobic conditions.

There are four methods in general use for the removal of oxygen.

1. *Mechanical*. When the air is replaced by a neutral gas like coal gas.
2. *Chemical*. When a substance is placed inside the receptacle which readily absorbs oxygen.
3. *Exhaustion*. When the air is removed by a vacuum pump.

4. *Combustion.* When some substance is burned inside the tube or vessel.

The gases which are used to replace the air by displacement are

Coal-gas,  
Hydrogen,  
Carbonic acid gas.

A very suitable substance for the absorption of oxygen and one which has the additional advantage of being easy to prepare and convenient to use is potassium pyrogallate which can be prepared by the action of caustic potash on pyrogallic acid. The most convenient as well as the most effective method of driving out the oxygen in a vessel is first to drive out mechanically as much as possible by means of coal-gas and then to absorb the remainder by the introduction of K. pyrogallate.

For the study of anaerobic bacteria it is advisable to 'catch' one from the outside and to defer testing the capacity of *Bac. megatherium* until the following exercises have been accomplished.

Exercise 44. *Method of searching for anaerobic bacteria.*

1. Place some water in a 500 c.c. beaker and in it immerse either a fragment of a potato, or a portion of a mushroom or a bit of elder pith.
2. Place the beaker, supported on a tripod stand, in a Bulloch vessel (see the explanation of Fig. 25).
3. In the bottom of the vessel place:
  - (a) 145 c.c. water,
  - (b) 2.4 grams dry pyrogallic acid,
  - (c) 109 grams caustic potash.
4. Open both taps (they must be well greased), connect one with a gas tap and the other with a tube leading into some place where the gas after passing through the vessel can escape to the outside.

5. Open both taps and keep them open until it is considered that the air inside the vessel has been displaced by coal-gas.
6. Close both taps and place the apparatus in an incubator at 37° C.
7. In a few days the water in the beaker will be ready for plating.

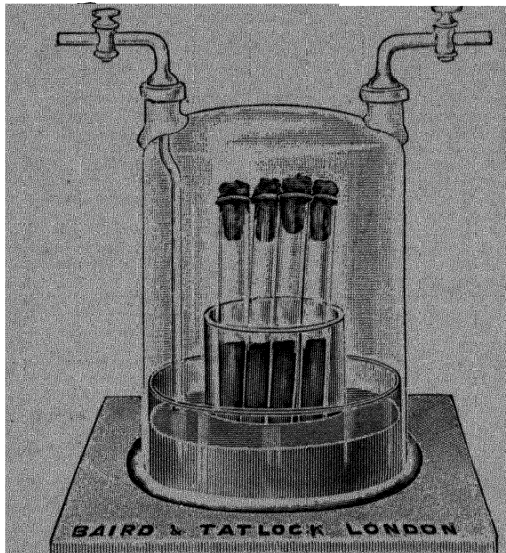

Fig. 25.—Bulloch Jar. The air inside the jar is replaced by a neutral gas (coal gas or  $\text{CO}_2$ ) after the tubes have been placed inside. When the air has been expelled the taps are closed.

Exercise 45. *Method of plating anaerobic bacteria.*

1. Heat an Agar-tube until the Agar melts.
2. Add to it a loopful from the water in the beaker (see Exercise 44).
3. Pour the contents of the tube into a fairly deep Petri-dish.
4. On a plate of glass erect a circular mound of plasticine equal in diameter to the diameter of the Petri-dish.

5. Inside the plasticine circle place 1 c.c. of 20% pyrogalllic acid solution and 1 c.c. of 20% Caustic Potash solution (see Fig. 32).
6. After the Agar has set, set the lower Petri-dish *upside down* on the plasticine mound, so that the rim of the dish rests on the mound all the way round. The Agar will now be resting on the ceiling of an air tight chamber.
7. Incubate at 37° C. until colonies appear in the Agar.

Exercise 46. *Cultivation of anaerobic bacteria.* Method I.

1. Pour about 1½ inches of Agar medium into a tube and keep it *vertical* until the Agar sets.
2. Touch one of colonies obtained by plating anaerobic bacteria (see Exercise 45) with a platinum needle and with it inoculate the Agar-tube.
3. Press some sterilised cotton-wool down the tube until it is about 1 cm from the Agar. This plug should be about 3 cms long.
4. Following this plug should be another, which it is not necessary to sterilise, of roughly the same size.
5. Pour on this second plug 2 c.c. of a 20% solution of pyrogalllic acid and 2 c.c. of a 20% solution of caustic potash.
6. Close the test-tube with an india-rubber stopper, which must be made absolutely air tight by smearing the top with paraffin-wax or plasticine.
7. Place tube in incubator at 37° C.

Exercise 47. *Cultivation of anaerobic bacteria.* Method II.

Special tubes for the cultivation of anaerobic bacteria may be obtained, in which provision is made to enable the operator to drive out the air in the tube with coal gas or some other neutral gas. Common forms of this kind of apparatus are shown in Figs 26, 27. The stopper has two openings, one for the entrance and the other for the exit of the gas; in some forms the apparatus is fitted with glass taps.

1. Make an Agar slope using the special tube instead of an ordinary test-tube.
2. Touch one of the colonies obtained by plating anaerobic bacteria (see Exercise 45) with a platinum needle and inoculate the Agar slope.

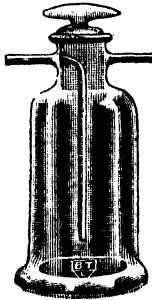

Fig. 26. — Apparatus for cultivation of anaerobic bacteria.

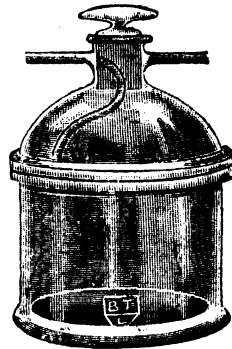

Fig. 27. — Apparatus for cultivation of anaerobic bacteria. Upper part is detachable. Connecting rims of two parts are made of ground glass, and when the rims are smeared with grease, the apparatus is airtight when the upper and lower portions are affixed.

3. Connect one tap with the gas-supply, and allow the gas to escape through the other tap.
4. When the air is considered to have been completely expelled, close the taps.
5. Place in incubator at 37° C.

Exercise 48. *Cultivation of anaerobic bacteria. Method III.*

1. Plug a long test-tube (about 8 ins. long) with cotton-wool and sterilise.
2. Melt 3 Agar-slopes and to each add as much glucose as will bring this substance up to two per cent. (See Exercise 36.)
3. Place about  $\frac{1}{2}$  c.c. of sterile water in a small sterile tube and rub into it a little material from one of the colonies from an anaerobic plate. (See Exercise 45.)

4. Inoculate the 3 Agar-tubes from this material.
5. After inoculation pour contents of one Agar-tube into the long test-tube and allow Agar to set.
6. After the Agar has set, pour into the tube the contents of the second Agar-tube, and when this Agar has set, pour into the same tube the contents of the third Agar-tube. The tube will now contain the contents of the three Agar-tubes one on top of the other.
7. Incubate at  $37^{\circ}$  C.

There will be markedly better growth in the bottom layer of Agar because this is the one which is furthest removed from the oxygen supply. The difference in the intensity of growth is accentuated by the addition of glucose the fermentation of which produces gas development.

Exercise 49. *Cultivation of anaerobic bacteria.* Method IV.

*Moore's Method.* This is the simplest of all the methods.

1. Inoculate an Agar-slope with an anaerobic species.
2. Dip a piece of filter-paper in alcohol, set it alight, place



Fig. 28.

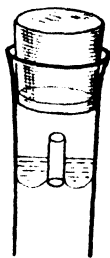

Fig. 29.

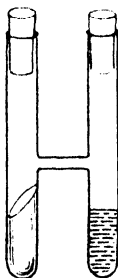

Fig. 30.



Fig. 31.

Figs. 28—31.—Various forms of apparatus for cultivation of anaerobic bacteria.

Fig. 28.—The oxygen-abstracting fluid is placed in the bulb at the lower end. The aperture of this bulb is made small so as to prevent the test-tube containing the culture from slipping down into the fluid contained in the bulb.

Fig. 29.—Buchanan-tube. An annular tube containing the oxygen-abstracting fluid is fitted into the upper part of the test-tube.

Fig. 30.—In this form the fluid for removing the oxygen is placed in a separate test-tube connected with the culture-tube by a horizontal arm.

Fig. 31.—The fluid in this apparatus is placed in cotton wool which is tightly fitted to the walls of the tube.

it inside the Agar-tube and close the latter with a well fitting rubber stopper.

3. Incubate at  $37^{\circ}$  C.

There are several ingenious devices for effecting the complete absorption of the oxygen inside the tube or vessel in which the anaerobic bacteria are growing. Some of these are shown in Figs 25—32.

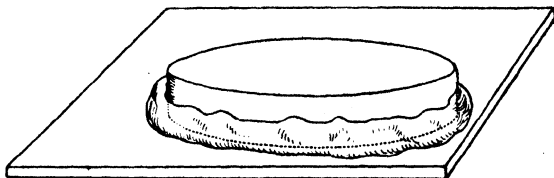

Fig. 32. — Apparatus for cultivation of anaerobic bacteria. The under part of a Petri-dish into which infected material has been poured is turned over and affixed to a circle of plasticene on a glass plate. The oxygen abstracting fluid is placed on the glass plate.

### Estimation of the size of bacteria and other small objects.

It is first of all necessary to ascertain the magnification of the microscope. For example it is necessary to know the diameter of the field of view which is presented to the observer when he is looking through his microscope.

Exercise 50. *Approximate estimation of the diameter of field of view of microscope* (using low-powered objective).

Method I.

1. Select a thin ruler with a  $\frac{1}{2}$  millimetre scale.
2. Place ruler on microscope-table and push it under the objective.
3. Adjust microscope so that the scale is in focus.

[Care should be taken not to push the scale completely across the field of view, otherwise the light will be totally excluded.]

4. In this way it can be seen how many divisions of the scale it takes to stretch across the diameter of the field of view.

Suppose we find that when one line on the scale is at the extreme left, the next is at the extreme right, of the

field of view (Fig. 33 a), then we know that the field of view =  $\frac{1}{2}$  m.m. in diameter. Next suppose we find that when one line is at the extreme left the next is placed as represented in Fig. 33 b it is obvious that the field of view is approximately  $\frac{3}{4}$  m.m. We can therefore judge of the

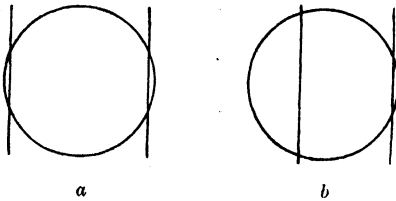

Fig. 33.—For explanation see text.

size of some small object that is under microscopical examination e.g. a bacterial colony by ascertaining how many times its length or diameter goes into the diameter of the field of view.

### Example.

An object under examination is roughly  $\frac{1}{3}$  of the diameter of field of view. The diameter of field is known to be approximately  $\frac{1}{2}$  m.m.

$$\text{object} = \frac{1}{3} \text{ of } \frac{1}{2} = \frac{1}{6} \text{ m.m.}$$

**Exercise 51.** *Approximate estimation of the size of an object of microscopic dimensions (using low-powered Objective). Method II.*

1. With a  $\frac{1}{2}$  millimetre scale at hand it is not difficult to make a dot of ink  $\frac{1}{2}$  millimetre in diameter on a piece of transparent paper.
2. Focus this dot and estimate the ratio which its diameter bears to the diameter of the microscope-field.

As a variant of this and the preceding exercise, two very minute dots may be made on transparent paper at a distance  $\frac{1}{2}$  m.m. apart, and then focussed to ascertain the ratio of the distance between the dots to the diameter of the field.

**Exercise 52.** *Approximate estimation of the size of an object; of microscopic dimensions (using a high-powered Objective). Method III.*

The principle of this method is the same as in the two preceding exercises: but as the magnification is so much

greater we must employ a much finer scale of division. Instead of the lines of a ruler we must work with a *micrometer slide* which is exactly like a ruler, only the lines are much closer and they cannot be seen except when viewed through the microscope. The lines on such a slide are usually divided into  $\cdot 25$ ths,  $\cdot 10$ th and  $\cdot 01$ th of a millimetre.

We can measure the diameter of the microscope-field by focusing the lines on the micrometer slide, when the diameter can be directly measured.

Thus supposing on focusing we find the lines arranged as shown in Fig. 40, in which the lines subdivide the field into 3 wider spaces (on the right) and 3 narrower spaces (on the left). A reference to the label gummed to the micrometer slide shows that each of the wider spaces mark off  $0\cdot 1$  m.m. and each of the narrower ones  $0\cdot 01$  m.m. The diameter of the field is therefore

$$\begin{aligned} & 3 \times \cdot 1 + 3 \times \cdot 01 \text{ m.m.} \\ & = \cdot 33 \text{ m.m.} \\ & = \frac{1}{3} \text{ m.m.} \end{aligned}$$

and the radius =  $\frac{1}{6}$  m.m.

If therefore we know that the radius is  $\frac{1}{6}$  m.m. the size of any object in the field can be approximately estimated by comparing its length with that of the radius.

Thus if the object appears to be approximately a third of the radius of the microscope-field in length, its dimension

$$= \frac{1}{3} \text{ of } \frac{1}{6} \text{ m.m.} = \frac{1}{18} \text{ m.m.}$$

**Exercise 53.** *Approximate estimation of the size of an extremely minute object.*

In dealing with bacteria, however, we need a still smaller unit of comparison than the radius of the microscope-field. For approximate estimations it is advisable to make the breadth of the bacterial cell our unit. Thus we know that the vast majority of bacterial cells of the *Bacillus* group (rod shaped forms) belonging to the soil, are  $1 \mu$  in thickness, and the largest of them is not more than  $1\frac{1}{2} \mu$ . Hence if we wish to measure, for example, the *length* of

bacterial cells, all we have to do is to estimate how many times the length is greater than the thickness. Thus if the length is four times the thickness the length

$$= 4 \text{ times } 1 \mu = 4 \mu.$$

Before making this estimation, however, the student must satisfy himself that the thickness of the organism is one that may be regarded as average. If the length of the cell (or filament) is more than 12 times the thickness, it is better to drop this unit of comparison, and revert to the radius of the field as the unit of comparison.

Exercise 54. *Accurate estimation of the size of an extremely minute object.* Method I.

The best apparatus for this purpose is undoubtedly Zeiss's Zeichnen-apparat. See Fig. 34. A small hole is bored in the prism A, so that when the eye is observing an object in the microscope the prism offers no hindrance to the direct view of the object. If a piece of paper (x) is placed on the table, it also as well as the surrounding objects is seen in the field of the microscope, reaching it by way of B N A D. In the microscope the object appears to be lying on the paper. A hand holding a pencil and placed on x will obviously also appear reflected in the microscope. The observer places the hand holding the pencil on the sheet of paper, and, looking through the microscope, uses it for tracing the object under examination on the sheet of paper.

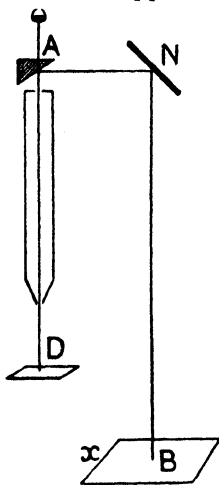

Fig. 34.

By next focusing a micrometer slide in the microscope when this operation is finished and tracing two of the lines marked in the slide on the same sheet of paper, the observer can find out the magnification under the same conditions.

Suppose that the object when traced on the paper measures 20 millimetres, and suppose that two lines on the micro-

meter scale which are known to be .01 m.m. apart, when traced on the paper measure .8 m.m., then obviously the magnification is 80, and the real size of the object under examination

$$= \frac{.8}{80} = \frac{1}{100} \text{ m.m.}$$

In the apparatus there are devices for regulating the amount of light from the two sources viz. from B by reflection and directly from the reflector of the microscope. As the paper and the object in the microscope thus receive their light from different sources, if one source happens to be very bright, the other is hardly visible. A glance at the apparatus in position will show the student the method employed for regulating the two sources of light.

A few objects should be accurately measured by this method.

Exercise 55. *Accurate estimation of the size of an extremely minute object.* Method II.

If the microscope is fitted with a *micrometer eyepiece*, the magnification of various objects in the field may be estimated directly. For the rapid estimation of the magnification of an object in the field of the microscope, the use of the micrometer eyepiece is to be strongly recommended. The great advantage of the apparatus described in the preceding exercise is that it enables us to *trace* the object under examination as well as to *measure* it, a very great advantage when an accurate presentment of the object is desired.

Exercise 57. *Estimation of the length and thickness of bacterial cells.*

1. Examine a 24—28 hour old agar-culture of *Bac. megatherium* under the microscope, using either a  $\frac{1}{6}$ th or  $\frac{1}{8}$ th objective.

Assume that the thickness of the cells is  $1\frac{1}{4} \mu$ .

2. Find approximately the length of the various individuals by estimating the number of times that the length is greater than the breadth, and multiplying this number by  $1\frac{1}{4} \mu$ .

3. With the aid of a micrometer slide (see Exercise 52) find the radius of the microscope-field.
4. Select a particular bacterial cell and estimate its length by finding the ratio of its length to that of the radius of the microscope-field. Thus, suppose we find the radius to =  $\frac{1}{6}$  m m. and the cell to be  $\frac{1}{8}$ th of the radius then length of cell

$$= \frac{1}{6} \times \frac{1}{8} \text{th} = \frac{1}{48} \text{ m m.}$$

5. By means of the Camera lucida, trace a few of the cells on a piece of paper (see Exercise 54), then place the micrometer slide under the microscope and trace a few of the lines on the same piece of paper. Estimate in this way the length and thickness of the bacterial cells (see Exercise 54).
6. Find the length and thickness of a few of the bacterial cells by means of the micrometer eye-piece.

Exercise 57. *Estimation of size of bacterial cells, by comparison with human blood corpuscles.*

1. Prepare Toisson's Fluid.

Sodium Chloride . . . . .	1 gram
Sodium sulphate . . . . .	8 grams
Glycerine . . . . .	30 c.c.
Water . . . . .	160 c.c.

2. Place two or three drops of this fluid in a watchglass.
3. Mix a loopful of blood from a pricked finger with the drops in the watchglass.
4. Place a drop of water on a slide and make it very slightly turbid with the bacterial matter under examination.
5. On another slide place a loopful of the diluted blood and mix with this a loopful from the drop containing the bacterial matter.

A normal red blood corpuscle is  $7.5 \mu$ . The size of the bacterial cells can be calculated by comparison with the known diameter of the red blood corpuscle.

### Evolution of Sulphuretted hydrogen.

The decomposition of organic matter by the saprophytic bacteria is attended in many cases by the evolution of this evil-smelling substance. We have only to remind ourselves of the element of luck that awaits the breaking open of the shell of some of our eggs to remind us that decomposition and the liberation of  $H_2S$  are frequently conjoined phenomena.

Exercise 58. *Evolution of Sulphuretted hydrogen.* Method I.

1. Inoculate a broth-tube with *Bac. megatherium*.
2. Moisten a strip of filter-paper in a solution of lead acetate, and affix it to the inside of the tube above the level of the broth.
3. Insert tube in incubator at  $30^{\circ} C.$  (approx.) and examine after 24 hours.
4. Observe that the filter paper has blackened owing to the formation of lead sulphide.

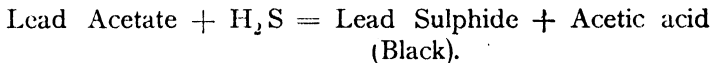

Exercise 59. *Evolution of Sulphuretted hydrogen.* Method II.

1. Fit up half-a-dozen Durham tubes (see Ex. 39) and fill each with broth.
2. Infect each with a pinch of earth or of dung.
3. Incubate at  $37^{\circ} C.$
4. Observe after 24 hours.

Most of the tubes will contain a copious supply of gas. Try the following experiment with each tube in which gas has collected.

5. Transfer gas to shorter tube, placing thumb whilst doing this on the opening of the shorter tube and keeping it there during the experiment.
6. Place in short tube a piece of filter paper soaked in lead acetate. In each case the filter paper will turn black owing to the formation of lead sulphide.

Exercise 60. *Evolution of Sulphuretted hydrogen.* Method III.

1. Add 0.1 gram *Pb. carbonate* to *Agar-tube* containing approx. 10 c.c. nutrient-agar.

2. Melt and pour contents into Petri-dish.
3. After the Agar has set, draw a platinum needle, infected with *Bac. megatherium*, across surface of Agar.
4. Place Petri-dish in incubator (about 30° C.).
5. After 3 or 4 days observe blackening in Petri-dish along line of streak.

The black colour is due to the presence of Pb. sulphide. The H<sub>2</sub>S developed by the bacillus has acted on the Pb. carbonate in accordance with the reaction:

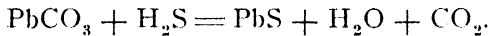

### **Milk Cultures.**

Some bacteria effect the coagulation of milk, and the fact may be used to assist in their diagnosis. By the addition of litmus to milk we have a medium which will record, in addition, whether acidity is developed as well as coagulation, when the medium is inoculated with bacteria.

#### *Exercise 61. Preparation of Litmus-milk.*

Add enough of a neutral litmus solution to sterilised milk to give the latter a distinctly purplish tint, only very fresh milk should be used, or milk that has been neutralised by the addition of some chalk.

#### *Exercise 62. Culture of Bac. Megatherium in litmus-milk.*

Inoculate with *Bac. megatherium* a tube of litmus milk. Incubate and observe whether a pink or red colour develops in the milk.

### **Second General Revision.**

In the first set of Exercises with *Bac. megatherium* we learnt the following facts concerning that organism.

1. The cells are rod-shaped.
2. They are motile.
3. They form *spores*.
4. They liquefy gelatine.
5. They develop gas in glucose-containing gelatine media.

6. They grow best under aerobic conditions.
7. They form a pellicle on the surface of broth.
8. They produce a slight alkaline reaction in broth cultures.

The above tests will serve for the identification of any one of the common organisms.

In most cases, however, it is necessary to know more about an organism than suffices for its identification. Our exercises in the second set of exercises have supplied us with more information concerning *Bac. megatherium*.

9. By staining the cells we found that *Bac. megatherium* has two kinds of reserve materials viz. *Volutin* and oil globules.
10. The cells react positive when stained by the *Gram Method*.
11. It is possible to stain the spores of *Bac. megatherium* and establish the fact that spores have two coats.
12. By staining for cilia we found that the cilia are disposed all over the cell. (We substituted another bacillus for *Bac. megatherium* in this exercise.)
13. When spores are sown in a proper medium they germinate.
14. *Bac. megatherium* forms a well defined capsule in broth cultures.
15. It liberates gas when cultivated in glucose-gelatine media.
16. Much information is to be obtained concerning bacterial species by ascertaining whether the broth in which they are growing is made acid, or alkaline or remains neutral. In glucose-containing media *Bac. megatherium* produces an acid reaction. It is customary to express acidity in terms of percentage of Sulphuric or Hydrochloric acid.
17. *Bac. megatherium* produces *Indol*, many species do not.
18. It is strongly *aerobic*. Some species grow best when oxygen is excluded.
19. In size *Bac. megatherium* must be considered a large bacillus. Methods of estimation of size of very small objects were considered.
20. *Bac. megatherium* liberates Sulphuretted hydrogen under appropriate circumstances. Some species have not this capacity.

## CHAPTER VIII.

The Isolation of Bacteria from soil, from hay-infusion and from air. Counting of Colonies. Estimation of rate of movement of bacteria. Medium for cultivation of chromogenic bacteria.

### The Isolation of Bacteria.

Bacteria are to be found almost everywhere and may be 'caught' from the air, or soil or water. It is important to know what kinds of bacteria exist in various habitats, and in industrial operations it is sometimes a paramount necessity to make observations on the bacteria which are present in certain fermenting liquids or in the surrounding atmosphere.

Exercise 63. *Isolation of bacteria from soil.*

1. Put a small pinch of soil into a sterilised plugged test-tube.
2. Fill test-tube with water from hot-water tap or with distilled water.
3. Place test tube in boiling water for two minutes. This will destroy all bacteria except such as are in the spore condition. This method will supply us with a spore-forming organism as, if we start from spores, the subsequent cells formed by their germination will normally form spores.
4. Melt a tube of nutrient gelatine (No 1 tube).
5. Shake the soil, let the coarser matter sink to the bottom, and then insert a sterilised Platinum-loop into the water.
6. Take out Plat. loop, and dip it into the melted gelatine. Shake tube gently to ensure distribution of soil particles.
7. Sterilise Plat. loop and lay it on rest.

8. Melt another nutrient-gelatine tube. (We will call this No 2 tube.)
9. Dip Plat. loop into No 1 tube, take it out and insert in No 2 tube.
10. Lay two sterilised Petri-dishes on table, pour into one of them the contents of No 1 tube, into the other the contents of No 2 tube.
11. Allow gelatine to set. Place Petri-dishes in some dust-protected place.

After a few days, the length of time depending amongst other things on the temperature, a number of *colonies* will appear on the plates.

12. With a sterilised Plat. needle touch one of the colonies and inoculate with it an Agar-slope.

All the descendants on the Agar-slope have as their ancestors the individuals which composed the colony, and all the individuals in the colony were derived from an individual which had entered the Petri-dish with the soil. Hence all the thousands which subsequently appeared on the Agar-slope were derived from a single individual. A growth of this kind in which all the individuals composing it are derived from a single individual is called a *Pure Culture*. The culture on the Agar-slope may now be studied in the same manner as was *Bac. megatherium*.

Exercise 64. *The Isolation of Bacteria from Hay-infusion.*

1. Chop up a handful of hay into small bits and place in boiling water for  $\frac{1}{2}$  hour.
2. Place hay in a thoroughly clean beaker.
3. Cover hay with sterilised water.
4. Place aside for a few days at room-temperature. A scum will form on the surface, in all probability made up chiefly of the hay-bacillus (*Bac. subtilis*).
5. Remove a loopful from the water just under the scum and transfer to a sterilised test-tube containing about two inches of sterilised water.
6. Sterilise Plat. loop.

7. Remove a loopful of the infected water and transfer it to an Agar-tube in which the agar has been melted.
8. Pour contents of Agar-tube into a sterilised Petri-dish.
9. Incubate at 30° C. (approx.).
10. Examine daily until colonies appear. The colonies of *Bac. subtilis* on Agar are roundish but under a low power of the microscope are seen to be composed of wavy, woolley kind of tufts of characteristic appearance.

Whatever kind of colonies appears, one of them should be touched with a sterilised platinum needle with which an Agar-slope should then be inoculated.

**Exercise 65.** *Isolation of bacteria from the air.*

1. Pour the contents of a Gelatine-tube into a sterilised Petri-dish and allow the gelatine to set.
2. Expose it in a room for 5 minutes.
3. Cover it up, place aside in a covered receptacle.
4. Examine daily until colonies appear.
5. These colonies will be of various kinds, the fluffy ones will be representatives of the Mould-family. Among the colonies that are not fluffy, but round, compact and of mucilaginous appearance, some will be composed of round bacteria (Coccaceae). If so one should be sub-cultured on an Agar-slope, and systematically examined after growth has taken place. The different kinds of colonies should be subjected to examination and set aside after sub-culture for future investigation.

### **The Counting of Colonies.**

Sometimes the number of colonies is so great that direct counting is not practicable. When this is the case it is obvious that we must limit our counting to a known fraction of the whole and compute the number on the whole plate by calculation.

**Exercise 66.** *The Counting of Colonies on Petri-dishes.*  
Method I.

1. Cut out a circular disc of paper of diameter equal to that of the Petri-dish.

2. Divide into 4 sectors as shown in Fig. 35 a.
3. Cut out Sector A altogether. See Fig. 35 b.
4. Cut out exactly half the Sector B, the part to be cut out being that shown in Fig. 35 b viz. x y z.  
(Do not cut *exactly* right up to x, otherwise the sector B is apt to become detached.)
5. Cut out a quarter of the Sector C viz. o x p.
6. Turn over the Petri-dish and place on it the disc after the bits have been cut out of it.

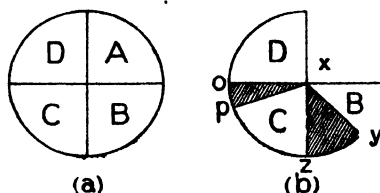

Fig. 35.

The colonies will be visible in three areas.

1. A quarter of the whole in sector A,
2. An eighth " " " " " B,
3. A sixteenth " " " " " C.

In sector D all are covered.

7. Count the colonies in sector x y z. If this cannot be conveniently done, count instead the colonies in the sector o x p.

Suppose we have selected the latter and have found it to contain 15 colonies.

(This counting must be made with a hand-lens.)

8. Twist the disc round a little way so as to bring the sector into a fresh part of the plate and count again. We now find let us suppose 13 colonies.
9. Twist again and thus bring a third portion into the sector o x p. We now find say 15.
10. Repeat the operation altogether about eight times. Our first, second, and third readings gave us respectively 15, 13, and 15 colonies.

Suppose our subsequent readings were respectively 16, 18, 4, 10, 13 colonies.

Add up we have

$$\begin{array}{r}
 15 \\
 13 \\
 15 \\
 16 \\
 18 \\
 4 \\
 10 \\
 13 \\
 \hline
 104
 \end{array}$$

Dividing by 8 to get the average

$$\frac{104}{8} = 13$$

The average number of colonies on an area equal to  $\frac{1}{16}$ th of the whole is therefore 13 and the total number on the plate is

$$13 \times 16 = 208. *$$

**Exercise 67. *The Counting of Colonies on Petri-dishes.***  
Method II.

The writer has elaborated the following method for counting colonies in cases where the total number is very large.

1. Find diameter of Petri-dish. Suppose this to be 8 cms.

Therefore radius = 4 cms = 40 m.m.

The colonies are therefore enclosed in an area

$$= \pi \times 40^2 \text{ sq. m m.}$$

2. Next focus the low-power of the microscope on the edge of a ruler divided into  $\frac{1}{2}$  millimetres and estimate the diameter of the microscope-field. (See Exercise 50).

Suppose we find the diameter of the field to be

$\frac{1}{3}$  m.m.

$$\text{radius} = \frac{1}{6} \text{ m.m.}$$

---

\* The writer has devised a colony-counter in which the angle which is made with the disc in the above exercise is registered on a scale, thus ensuring greater accuracy.

and area of microscope-field

$$= \pi \left(\frac{1}{6}\right)^2 \text{ sq. m.m.}$$

3. Next focus the microscope on the Petri-dish and count the number of colonies in the area under view. Move microscope up and down so as to be certain that all the colonies have been seen, both those under as well as those on the surface. Shift the Petri-dish and count the number on the new area. Take in this way at least 20 readings.

Suppose we find the readings to be as follows.

6	5
4	2
2	1
1	4
4	6
5	5
7	4
8	7
6	6
5	2
-----	-----
10 readings 48	10 readings 42

Total 20 readings = 90  
 average = 4.5.

We have seen that,

$$\text{Total area} = \pi \times 40^2 \text{ sq. m.m.}$$

And area of microscope field

$$= \pi \times \left(\frac{1}{6}\right)^2 \text{ sq. m.m.}$$

Total number of colonies

$$\begin{aligned}
 &= \frac{\text{Total area}}{\text{area of microscope-field}} \times 4.5 = \frac{40^2 \times 4.5}{\left(\frac{1}{6}\right)^2} \\
 &= 4.5 \times 40^2 \times 6^2 \\
 &= 259.200.
 \end{aligned}$$

Exercise 68. *Estimation of the rate of movement of bacteria.*

It is evident that we must take a measured *space* and count the time that is taken to traverse this space.

1. Estimate the diameter of the microscope field, using a high-powered objective (see Exercise 50).
2. Place a drop of the bacterial fluid on a slide, and then place a coverslip gently over the drop.

Examine under the microscope. Two conditions must prevail before attempting the experiment.

1. The liquid under the coverslip must be in a state of rest.
2. The number of individual bacteria in the field must not be so great that it is difficult to follow the movement of any one particular individual; the individual chosen for examination must also have a clear path without obstruction from other bacteria which cannot be secured if there are many in the field.
3. With a stop-watch find the number of seconds that it takes any particular individual to cover say  $\frac{1}{2}$  the radius or the whole of the radius.

Calculate the results in  $\mu$  per sec.

*Example.*

Suppose it is found that the diameter of the field

$$\begin{aligned} &= \frac{1}{3} \text{ m.m.} \\ \text{radius} &= \frac{1}{6} \text{ m.m.} \\ &= \frac{1000}{6} \mu. \end{aligned}$$

Suppose a microbe takes 10 seconds to traverse a distance which is estimated to  $= \frac{1}{2}$  radius

$$\frac{1}{2} \text{ radius} = \frac{500}{6} \mu.$$

$$\text{In 10 seconds distance traversed} = \frac{500}{6} \mu$$

$$\text{" 1 second " " " " } = \frac{50}{6} \mu$$

$$\text{Speed} = 8\frac{1}{3} \mu \text{ per sec.}$$

It is well to realise how much this means.

$$\begin{aligned} 10 \mu \text{ per sec.} &= \frac{10}{1000} = \frac{1}{100} \text{ m.m. per sec.} \\ &= 36 \text{ m.m. per hour.} \end{aligned}$$

Hence a microbe starting to traverse the length of a foot ruler would cover a little less than  $1\frac{1}{2}$  inches in the hour and about 8 hours to cover the foot.

Exercise 69. *Growth of bacteria on glycerine-potato.*

This medium is recommended in growing *chromogenic bacteria*.

1. With a cork-borer cut cylindrical portions out of a healthy potato. These portions should be about 4 cms long and about 1.5 cms in diameter.
2. Halve each cylinder diagonally (see Fig. 36) and cut away any portions of skin that may not have been removed.
3. Make a solution of 1:1000 Sodium Carbonate and soak the pieces in this substance for 24 hours (not longer).
4. After 24 hours transfer the pieces to water containing 5% glycerine and leave for 24 hours (not longer).
5. Sterilise wide test-tubes, place in each 1 c.c. of sterile water, and a glass rod, 2½ cms long and about ½ cm in diameter.
6. In each tube insert a piece of potato (see Fig. 36) with the broad end of the wedge in the downward position. It will be seen that by this arrangement the potato will be supplied with moisture without being actually in contact with the water.
7. Plug tubes with cotton-wool and sterilise by placing in steam steriliser (100° C.) on 4 successive days for 20 minutes each time.

## CHAPTER IX.

Examination of Drinking Water. Identification of *Bac. coli communis*. Total count of bacteria in drinking water. Methods of search for *Bac. enteritidis sporogenes*.

### The Examination of Drinking Water.

However pure may be the gathering ground of any particular body of natural water, it cannot escape some contamination, however slight, from organic matter. As this organic matter is the source from which the bacteria in the water draw their sustenance, the number of bacteria in the water bears a direct ratio to the amount of organic matter in it: and purity of water means freedom from organic matter. The first examination should therefore take the form of a total count of the bacteria in a measured amount of the water in question. Roughly speaking if the number of bacteria per cubic centimetre is in the hundreds, the water can be regarded as above suspicion provided that the further tests given below do not produce evidence of a contrary nature. If the number reaches thousands per cubic cent. there is distinct ground for suspicion but there must be confirmation. If, however, tens of thousands are found per cub.cm., then the water cannot be regarded as safe for drinking. It is not so much the fact *per se* of the presence of a large number of bacteria that raises suspicion for milk normally contains millions per cub.cm. and we know that no evil but beneficial effects normally follow the drinking of milk. If, however, we consider the sources from whence spring the organic matter that is found in natural waters we see that there is a profound difference in the two cases. The organisms that thrive on the albuminoid and sugar contents of milk are harmless and so well adapted

to their medium that normally their multiplication excludes any chances that other organism have of multiplying and of forming noxious products. It is different, however, with the organic content of a natural water. The gathering ground of the latter may be of a boggy nature, or consist of highly manured soils. Water drawn from wells may become infected owing to proximity to exposed excrement or sewage. The organic matter which is derived from such sources furthers the multiplication of noxious bacteria and there will be no lack of them in waters of this kind. The commonest organism in excrementally contaminated waters is *Bac. coli communis* and the number of this microbe in water serves as a measure of its contamination. This method gives us a delicate means for detecting impurity such as no chemical analysis can hope to emulate. Whilst the total number of bacteria in a water serves as a guide indicating the total amount of organic matter, the number of *Bac. coli* tells us how much of this organic matter is of a nature that is positively detrimental to the public health. Other corroborative methods of detecting sewage-contamination will be given in the following pages.

We shall do well to study *Bac. coli* in detail before proceeding to the examination of drinking water.

*Distinguishing characters of Bac. coli communis* (opt. temp = 37° C.).

1. *Nutrient-agar* abundant growth of a light-grey colour: small bacillus.
2. *Gram Stain* Negative.
3. *Nutrient gelatine*—No liquefaction. Abundant gas.
4. *Spores*. Not formed.
5. *Motility* Positive.
6. *Gelatine-Plate* Smooth grey colonies. Thin surface growth, not corrugated.
7. *Relation to oxygen*. Aerobic and facultative anaerobic
8. *Milk culture acidity*; Positive.

*Coagulation*. Positive.

9. { *Lactose-broth* } *acidity*. Positive.  
    { *Glucose-broth* } *Gas*. Positive.

It must be borne in mind that there are several varieties of this organism, but all possess the characters given above. The student is advised to consult more advanced and more specialised treatises for fuller information with regard to the varieties of *Bac. coli communis*.

The identification of particular varieties is not required in the routine work of the bacteriological analysis of water.

Exercise 70. *The identification of Bac. coli communis.*

1. Place a couple of drops of sterile water in a small sterile test-tube. Infect the water with *Bac. coli*.
2. Dip a sterilised Plat. loop into the infected water.
3. Make following cultures.
  - (a) Nutrient-Agar.
  - (b) Gelatine-stab.
  - (c) Gelatine-plate.
  - (d) Milk.
  - (e) Lactose-broth.
  - (f) Glucose-broth.

Incubate a, d, e, f at 37° C.

„ b and c at room-temperature.

It will not be out of place at this point to place before the student a few figures from official statistics as a measure of guidance in the interpretation of his results.

The watershed of the River Vyrnwy (tributary of the Severn) has been formed into a large artificial lake by means of a dam. This lake is one of the main water supplies of Liverpool. A regular flow of water is allowed out of the dam and this of course flows into the Severn.

*Streams entering Lake Vyrnwy* — One sample had 1 *B. coli* per c.c.: majority of streams showed purer water than that represented by 1 *B. coli* per c.c.

*Soil of watershed.* *B. coli* absent in :1 gram and in 0·02 gram of soil. Number in larger quantities of soil not stated.

*Water of the Lake* — Average number of bacteria of all kinds 31 per c.c.

Here all results show a natural water practically free from pollution. The watershed is carefully protected from

any source of contamination. The water which flows out of Lake Vyrnwy into the Severn, naturally receives numerous additions from various sources, before reaching that river and in its course near inhabited dwellings some of these additions increase the intensity of pollution considerably.

12 Samples of water from land-drains. Coli absent in 1 c.c.

1 Sample " " " land-drain. 19,000 Coli per c.c.

The last shows an extraordinarily bad state of pollution. Further search revealed the fact that the land drain containing 19,000 per c.c. received the sewage of a Workhouse in the neighbourhood.

*Total Count in Land-drains.* From 100 to 3000 per c.c.

*B. coli in small brooks entering river* 24 per c.c. as average of 17 Samples. These brooks were obviously polluted.

*Total count in River Severn.* Average 10,000 per c.c.

*Bac. coli in River Severn.* Average 11 per c.c.

Exercise 71. *Preparation of McConkey's Bile-salt Lactose-agar.*

1. Mix together the following:

10 grams Peptone.

2,5 " Sodium-taurocholate.

7,5 " Agar.

500 c.c. tap water.

2. Heat in steriliser till there is complete solution.

3. Mix with white of egg and filter.

4. Add to filtered liquid 5 grams of lactose.

Exercise 72. *Preparation of McConkey and Hill bile-salt broth.*

1. Mix together the following:

$\frac{1}{2}$  gram Sodium taurocholate.

$\frac{1}{2}$  " glucose.

2 grams peptone.

100 c.c. water.

2. Dissolve by heat.

3. To filtrate add enough neutral litmus to give a distinct colour.

**Search for *Bac. coli communis*.**

It will be found far more convenient and, incidentally, also more accurate if in the search for *B. coli* the water be added directly to the tubes. It is not advisable to attempt to reduce the volume of the water under examination (e. g. by the filter-brushing method or by boiling under reduced pressure).

Exercise 73. *Search for B. coli. Method I.*

1. Pour 10 c.c. (approx.) of McConkey's bile-salt-agar (Exercise 71) into each of 5 sterilised tubes.
2. Add to each of the tubes 10 c.c. of the water under examination.
3. Set 5 sterile Petri-dishes on the table.
4. Pour contents of tubes each into a Petri-dish.
5. Incubate at 37° C.

Note the colonies that appear on the plates within the first 48 hours. The *Coli* surface colonies are roundish, irregular with flattened tops, white with a yellow or orange spot in the centre. It may be assumed that all the colonies that appear within 48 hours belong to the *Coli* family. One or two of the colonies should be subcultured (See Exercise 70).

Suppose 2 colonies appear within 48 hours, and on sub-cultivation are identified as *Bac. coli*.

Then as there were 5 tubes and into each we had placed 10 c.c. of water it follows that

50 c.c. of the water contain 2 *Bac. coli* therefore there we have 1 *Coli* per 25 c.c.

Exercise 74. *The total count of bacteria in a sample of water.*

In the search for *B. coli* detailed in the above exercises, every effort was made to bring about the conditions which were favorable for the cultivation of *B. coli*, or else an unfavorable factor was introduced which was less unfavorable to this organism than to the others (viz. the introduction of *Na. taurocholate*). In making the total count our mode of procedure must be different, we must use a medium which will allow

every one or at least the vast majority of the bacteria in the sample to form colonies. It is necessary therefore to give them enough room on the plates to form colonies comfortably.

1. Set 2 sterilised conical flasks (30 to 50 c.c. capacity) on the table. Each should be plugged with cotton wool.
2. Sterilise a number of 1 c.c. pipettes.
3. Add 9 c.c. sterile water to each of the three conical flasks.
4. Lift up 1 c.c. of the water to be examined with a pipette and add to contents of one of the conical flasks (Call this flask No. 1).
5. Lay pipette aside and do not use it again for this experiment.
6. Lift up another pipette and after shaking No. 1 flask thoroughly, transfer 1 c.c. from it to another conical flask (No. 2).
7. Set 2 sterile Petri-dishes on the table.
8. Melt 2 Nutrient-agar-tubes.
9. Pick up a third pipette, and with it transfer 1 c.c. from No. 1 flask into one of the melted Agar-tubes.
10. Pour contents of the Agar-tube into one of the Petri-dishes.
11. With a fourth pipette, remove 1 c.c. from No 2 flask, pour contents into another of the melted Agar-tubes, then empty contents of Agar-tube into the second Petri-dish.
12. Place both Petri-dishes in Incubator at 28°—32° C.

#### *Calculation.*

Flask No 1 contained	.	9 c.c. water
To it was added	. . .	1 c.c. of sample-water
		Total = 10 c.c.

Hence if we remove 1 c.c. from this flask this 1 c.c. will contain  $\frac{1}{10}$  c.c. of the sample water. When therefore we added 1 c.c. from this flask to the Agar-tube and plated the contents, we really added only  $\frac{1}{10}$  th of a c.c. of the sample water, the rest viz.  $\frac{9}{10}$  c.c. being

part of the 9 c.c. sterile water. [It is assumed that the mixture has taken place with uniformity.]

13. Take out Petri-dish No. 1 and count the colonies. [See Exercises 68 and 69.]

Suppose we find 54 colonies  
there are 54 bacteria in  $\frac{1}{10}$  c.c.  
total per c.c. = 540.

14. Next count the colonies in second Petri-dish. Suppose we find 6.

*Calculation.*

The same mode of reasoning as above will show that the second Petri-dish received only  $\frac{1}{100}$  c.c. of the sample-water thus

Flask No. 1 received  $\frac{1}{10}$  c.c. sample-water.

Flask No. 2 contains 9 c.c. water + 1 c.c. of water from Flask No. 1.

1 c.c. of Flask No. 1 contains  $\frac{1}{10}$  c.c. sample-water.

1 c.c. from Flask No. 2 contains  $\frac{1}{10}$  of  $\frac{1}{10}$  c.c. =  $\frac{1}{100}$  c.c. sample-water.

6 colonies are obtained from  $\frac{1}{100}$  c.c. sample-water.

1 c.c. sample water contains 600 bacteria.

We have two results

540
600

Average = 570.

Ans. 570 bacteria per c.c. sample-water.

*Caution.*

Care must be exercised that the sample-water should correspond as nearly as possible to the same water in nature. To this end the collecting vessels must be sterilised and the water examined as soon as possible after collection.

**Supplementary Exercises in Water-Examination.**

The following exercises serve a useful purpose to supplement those already given for the analysis of water.

Exercise 75. *The Search for Bac. enteritidis sporogenes.*

This organism is supposed to cause outbreaks of epidemic diarrhoea. It is present (about 100 per c.c.) in crude sewage and entirely absent from pure water and virgin soil. If water is very much contaminated, showing obvious sewage pollution, an attempt should be made to ascertain if *B. enteritidis sporogenes* is present. This organism has two great advantages for purposes of isolation.

1. It forms spores.
2. It grows best under anaerobic conditions.

Hence if we heat the sample up to about 80° C. all organisms will be killed except those in the spore-condition. This limits the numbers considerably. Further, if the culture be made under anaerobic conditions only spore-forming anaerobes will develop.

1. Place about 5 c.c. of sample-water in a sterile tube and insert in a pan containing water at about 80° C. Keep tube in water at this temperature for about 15 minutes.
2. Melt contents of Nutrient-agar tube.
3. Pour the heated sample-water into Agar-tube.
4. After mixing contents pour into a sterile Petri-dish, following directions given in Exercise 45.
5. Incubate at 37° C.

All the colonies that appear within 5—7 days may be regarded as *Bac. enteritidis sporogenes*.\*

Exercise 76. *To find the number of gelatine-liquefying bacteria in 1 c.c. of sample.*

If the contamination is known to be very large this exercise may be set on foot to give a measure of confirmation to the other exercises. The value of the test consists in this, that it is known that not only does crude sewage contain many liquefying bacteria, but it is known that many of these are of an undesirable kind.

---

\* It is possible that the colonies may be *Bac. butyricus* or *Bac. cadaveris* but not probable if pollution is known to be due to sewage.

1. Dilute 1 c.c. of sample with 9 c.c. of sterile water. Remove 1 c.c. from mixture and dilute with 9 c.c. sterile water.
2. Remove 1 c.c. from second mixture and pour into tube of melted gelatine.
3. Plate on Petri-dish.
4. **Examine daily.** Count the number of liquefying colonies.

*Calculation.*

Amount poured into gelatine tube contained  $\frac{1}{100}$  c.c. of original sample. Suppose there are 4 liquefying colonies.

Number of liquefying colonies = 400 per c.c.

Hence sample contained 400 bacteria per c.c. which were capable of liquefying gelatine. Other supplementary exercises will suggest themselves to the student after he has accomplished the exercises in connection with the bacteriological examination of sewage.

## CHAPTER X.

Methods of Examination of Sewage. Dilution of Sewage:  
Total-count: Number of Bac. coli in Sewage:  
Indol-tests: Examination for Bac. enteritidis.

### **Sewage and Sewage-Effluents.**

Before examining a sewage or an effluent consideration must be given to the fact that it is possible that all life in the sewage may have been destroyed owing to admixture with trade effluents containing ingredients inimical to life. There will therefore be little use in making a bacteriological examination until some information has been obtained on this point.

*Exercise 77. To ascertain whether a fluid contains living bacteria.*

1. Take up a loopful of fluid with a ster. platinum loop.
2. Transfer to Agar-slope.
3. Incubate for 24 hours at room-temperature or at 30° C.

If growth is perceptible after this interval, the exercises set below may be taken in hand. The next procedure, if the bacteria in Sewage have not been killed, is to secure a dilution such that it will be possible to deal adequately with the fluid. Domestic Sewage may contain as many as 100 million bacteria per cub.cm. The method of dilution is the same as for drinking water only the dilution must be carried further.

*Exercise 78. Dilution of Sewage.*

1. Place 6 small flasks on table each containing 9 c.c. of sterile water.

2. To No. 1 flask add 1 c.c. of sewage under examination.
3. No. 1 flask will now contain 10 c.c. Remove 1 c.c. with sterile pipette from No. 1 flask. This 1 c.c. will contain  $\frac{1}{10}$  c.c. of sewage. Transfer this 1 c.c. to No. 2 flask.
4. No. 2 flask will contain:
  - 9 c.c. sterile water.
  - 1 c.c. of water containing  $\frac{1}{10}$  c.c. sewage.
5. Remove 1 c.c. with sterile pipette from No. 2 flask. This 1 c.c. will contain  $\frac{1}{100}$  c.c. of sewage. Transfer this 1 c.c. to No. 3 flask.
6. Carry on the dilution in same manner until No. 6 flask is reached.

If therefore we take 1 c.c.

from No	1	flask	we	remove	$\frac{1}{10}$	c.c.	Sewage.
"	No. 2	"	"	"	$\frac{1}{100}$	"	"
"	No. 3	"	"	"	$\frac{1}{1000}$	"	"
"	No. 4	"	"	"	$\frac{1}{10,000}$	"	"
"	No. 5	"	"	"	$\frac{1}{100,000}$	"	"
"	No. 6	"	"	"	$\frac{1}{1,000,000}$	"	"

Exercise 79. *To find total number of bacteria in a sample of Sewage.*

1. With sterile pipette remove 1 c.c. from No. 5 flask (See Exercise 77).
2. Melt contents of gelatine-tube.
3. Transfer the 1 c.c. into the gelatine.

In order to allow as little as possible of this 1 c.c. to remain adherent to the walls of the pipette, it is advisable, after transferring the water into the gelatine, to draw up once more from the mixture of gelatine and the added 1 c.c. of water, and then blow the drawn up fluid back again into the tube. Repeat this operation two or three times.

4. Transfer contents of gelatine-tube to Petri-dish.
5. Incubate at room-temperature or at 20° C.

6. After two or three days (or longer if necessary) count the colonies. (See Exercises 68 and 69.)

Suppose the whole plate contains 240 colonies.

Therefore  $\frac{1}{100,000}$  c.c. Sewage contains 240 bacteria  
 " " " " " 24,000,000 "

A cubic centimetre of water should be taken from No. 6 and plated in the same way. The number of colonies in this case must be multiplied by a million to find the number of bacteria per cub.cm. The average of the two readings must be taken as the number of bacteria per cub.cm.

- Note.* 1. It is well to bear in mind that the exercise must be carried out with very strict attention to the sterility of the various apparatus that are employed. In our calculations above we have to multiply the number of colonies in the one case by 100,000, in the other by 1,000,000. The result of the entrance of each 'intruder' into the plates will mean therefore an error of either 100,000 or 1,000,000 in our final result.
2. When we blow our 1 c.c. from the pipette into the gelatine-tube, every microbe left adhering to the walls of the pipette results in an error of 100,000 or 1,000,000 in the final result. Some allowance should be made for this, and a twentieth added to the final result.

The observance of the following rules will help the student to obtain fairly consistent results.

1. See that all the apparatus is thoroughly sterile.
2. Make the dilutions with accuracy.
3. After each dilution mix thoroughly.
4. After blowing out the water from the pipette into the tube, which contains the 9 c.c. of water, suck up and blow out the mixture, several times so that the number of bacteria adherent to the walls of the pipette may be as few as possible.
5. A pipette must not be used more than once in the same experiment.
6. Count the colonies with great care.

**Exercise 79.** *Total Count of Bacteria when incubated at 37° C.*

It is useful to know how many of the bacteria are of a kind that grow best at the temperature of the body.

Proceed exactly as in Exercise 78 but use nutrient-agar in place of gelatine.

Count the colonies after 24 hours and make the calculation in the same way as in the preceding exercise.

**Exercise 80.** *To find the number of Bac. coli (and allied forms) present in a sample of Sewage or Sewage-effluent.*

We may emphasize once more the importance of a thorough knowledge of *Bac. coli*. The presence of *Bac. coli* marks the presence of excremental constituents either by direct or indirect contamination, and the numbers of this organism present in a sample gives the latter at once its biological status, and its potential capacity for undermining the public health.

1. Melt 10 c.c. of nutrient gelatine and pour into a Petri-dish. Allow gelatine to set.
2. Take 0.1 c.c. from No 3 dilution (see Exercise 77) and pour it on surface of gelatine in Petri-dish,
3. Spread out the liquid over the whole of the surface of the gelatine.

[A sterilised Platinum spreader is the best instrument for spreading. If a spreader is not available a small piece of wire can be bent in the form of a triangle and used for the purpose. The apex is held between thumb and forefinger, whilst the base is laid on the gelatine. It is an easy matter to draw the base over the surface of the gelatine and thus spread the liquid.]

4. Incubate at 20° C.

We have next to recognize the *Bac. coli* colonies. In this experiment all the colonies will appear on the surface and hence will exhibit their characteristic growths. The student must make himself acquainted with the appearance of *Bac. coli* surface colonies on gelatine and it would be well to have at hand a Petri-dish

containing surface colonies on gelatine of this organism for purposes of comparison. All colonies resembling *Bac. coli* in their manner of growth should be sub-cultured. These are smooth, thin surface growths, not corrugated. With practice they are easily distinguishable from most of the others.

5. Make the following cultivations from each colony of this kind.
 

A. Lactose-broth	}	(See Exercises 39—42.)	
B. Glucose-broth			
C. Litmus-milk.			(See Exercise 66.)
D. Gelatine-Shake Culture.			(See Exercise 13.)
6. Test further for
  - E. Indol formation.
7. Verify the fact that the colonies are made up of rod-cells and that these cells are Gram negative.

*Bac. coli* produces both gas and acidity in lactose- and glucose-broth; in the litmus-milk culture the litmus is turned red and the milk coagulated: gas develops in the gelatine shake but no liquefaction takes place.

Suppose we find 4 Colonies of this kind.

Then 1 c.c. of No. 3 dilution contains 4 *Bac. coli*. Hence 1 c.c. of No. 3 dilution contains 40 *Bac. coli*.

Now 1 c.c. of No. 3 dilution =  $\frac{1}{1000}$  c.c. of Sample. Hence 1 c.c. of Sample contains 40,000 *Bac. coli*.

Exercise 81. *To test a Sewage or Sewage-effluent for Indol-forming bacteria.* (See Exercises 43 and 44.)

Indol-forming bacteria are absent as a general rule from pure waters and virgin soils, and abundant in such places when they become contaminated with excremental matter. A negative result is of more value than one that is positive as whilst a negative result shows the absence of *B. coli* and its allies (which all produce Indol) a positive result does not necessarily indicate the presence of *B. coli* (or its allies) for other bacteria also produce Indol.

According to many, however, quite apart from the evidence that is afforded of the presence or absence of *B.*



## 3. Inoculate the 4 tubes.

1 c.c.	from No. 1 flask	to first	tube
1 "	" "	No. 2 "	" " second "
1 "	" "	No. 3 "	" " third "
1 "	" "	No. 4 "	" " fourth "

[The 4 flasks should previously have been kept at 80° C. for about 10 minutes, in order to kill all bacteria that are not in the spore-condition.]

## 4. Cultivate under anaerobic conditions at 37° C. [See Exercises 48—51].

After 1—2 days examine tubes to see if the 'enteritidis' change has taken place.

## 'Enteritidis' Change.

The cream is torn or altogether dissociated by the development of gas, so that the surface of the medium is covered with a stringy pink white mass of coagulated casein enclosing a number of gas bubbles. The whey shows an acid reaction and smells of butyric acid.

If we had diluted crude sewage in the manner indicated in Exercise 77, we should expect the 'enteritidis' change, in the tube to which 1 c.c. from No. 2 flask ( $= \frac{1}{100}$  c.c. sewage) had been added. The chances are only one in ten that this change will appear in the tube to which 1 c.c. from No. 3 flask had been added.

Exercise 83. *To test street-mud for faecal contamination.*

In the streets of towns animal traffic is apt to engender much faecal contamination on the surface, and may in dry weather become a menace to the public health. A sample of street-mud suspected of faecal contamination may be tested in the following manner.

1. Sterilise tubes each containing about 15 c.c. of milk, and supplied with a tight-fitting rubber stopper.
2. Heat the milk sufficiently to expel oxygen contained in it.
3. Bend the heads of 4 long pins (about 1½ ins) in manner shown in Fig. 37.

4. Stick the pins, one into each stopper as shown in Fig. 37.
5. Weigh 1 gram of the suspected mud and place in a clean beaker together with 100 c.c. hot water.
6. Keep the mixture at (roughly) 80° C. for 20 minutes by alternately withdrawing or inserting the bunsen according as the temperature exceeds or falls below 80° C.
7. Allow the mud to settle then pour the supernatant liquid into a clean beaker.
8. Carry out the Houston dilution with 3 flasks (see Exercise 77).
9. Inoculate one tube with 1 c.c. of the undiluted mixture, another with 1 c.c. from flask No. 1, another with 1 c.c. from flask No. 2, and the fourth with 1 c.c. from flask No. 3.
10. Attach a piece of filter paper soaked in alcohol to each pin of the 4 stoppers.
11. Set a light successively to each filter-paper and insert the stopper. It must be so arranged that the filter-paper does not touch the liquid when the stopper is inserted.
12. Incubate at 37° C.

Only bacteria in the spore condition, and only those of this class that are capable of developing in the absence of oxygen will be able to grow under the conditions of the experiment. We are practically limited to *Bac. enteritidis sporogenes*. If it is present it will produce the enteritidis effect.

[Sometimes the pressure of the gas that is developed blows out the stopper, but the 'enteritidis' effect is produced long before this happens.]

Exercise 84. *To test a Sewage or Sewage-effluent for Streptococci.*

As *Streptococci* are present in abundance in the intestinal evacuations of animals: and as they rapidly lose their vitality in water: and as those bacteria are absent from virgin soils and the waters drained from such soils, the presence of streptococci in a water under examination indicates recent pollution.

*Search for Streptococci.*

1. Pour contents of 4 Agar-tubes each into a Petri-dish and allow Agar to set.
2. Inoculate.

First	tube	with	·1	c.c.	from	Flask	No.	1
Second	"	"	"	"	"	"	"	2
Third	"	"	"	"	"	"	"	3
Fourth	"	"	"	"	"	"	"	4

[See Exercise 77.]

Spread liquid over the solid Agar as indicated in Exercise 80.

3. Incubate at 37° C.
4. After 48 hours examine colonies microscopically and ascertain whether any are made up of cocci arranged in a row like a string of beads. The rows will probably be very short, or considerably bent, so much so that often only a confused mass of round cells will be seen. Some, however, will show the bead arrangement. Suppose that 3 colonies of this kind are seen in the plate containing ·1 c.c. of No 2 dilution and none in plate containing ·1 c.c. No 3 dilution.

In ·1 c.c. containing  $\frac{1}{100}$  c.c. sample are found 3 streptococci.  
Hence: In 1 c.c. containing  $\frac{1}{100}$  c.c. sample are found 30 streptococci.

Hence: 1 c.c. of pure sample contains **3000** streptococci.

*Exercise 85. To test a badly polluted water for B. coli by means of neutral-red broth.*

1. Prepare neutral-red broth.

1. 100 c.c. Broth (See Exercise 2).

2. 0·3 " of 1% solution of neutral-red.

2. Prepare the usual dilutions (See Exercise 77).
3. Pour 10 c.c. of broth into each of four tubes.
4. Inoculate the four tubes each with one c.c. respectively from the flasks No. 2, No. 3, No. 4, No. 5. [See Ex. 77.]
5. Incubate at 37° C. and examine after 48 hours.

A positive result is indicated by a change in the colour of the contents of the tube from red to a fluorescent yellowish green. This means that the neutral red has been reduced. Now it is known that *B. coli* and its allies effect this reduction. A negative result is therefore valuable as the absence of *B. coli* and all bacteria like it is indicated. A positive result shows the presence of reducing bacteria, but it is not certain that the reduction has been caused by *B. coli*. Suppose we get the following result with neutral-red broth.

Flask	Inoculated with			
	1 c.c. from No. 2 flask.	1 c.c. from No. 3 flask.	1 c.c. from No. 4 flask.	1 c.c. from No. 5 flask.
Amount of sample in c.c.	$\frac{1}{10}$	$\frac{1}{100}$	$\frac{1}{1,000}$	$\frac{1}{10,000}$
Result of Inoculation	+	+	-	-

This indicates that there are no *B. coli* in  $\frac{1}{10,000}$  c.c. Hence that there are less than 1000 *B. coli* per c.c. of the sample. As crude domestic Sewage contains 100,000 *B. coli* per c.c., the pollution is only a hundredth that of crude Sewage. If the sample were from an effluent, this result would justify the water being 'passed', as a non-potable liquid. Its pollution is not great enough to be a public nuisance.

Exercise 86. To find the number of *B. coli* and allies by litmus-milk cultures.

*Bac. coli* and its allies clot milk and render it acid.

1. Prepare some sterilised milk and add enough of a litmus solution to it to make it slightly purple.
2. Prepare the usual dilutions from the sample under investigation (See Exercise 77).
3. Inoculate 4 tubes of litmus-milk, with 1 c.c.,  $\cdot 1$  c.c.,  $\cdot 01$  c.c., and  $\cdot 001$  c.c. respectively.
4. Incubate at  $37^{\circ}$  C.

If no clotting of the milk and no reddening of the litmus take place with .001 c.c. of the sample, the absence of *B. coli* and allies from  $\frac{1}{10000}$  c.c. of the sample may be inferred. [See preceding exercise for the argument upon which this inference is based].

A negative result with .001 c.c. of the sample comes within the standard deemed necessary to justify a polluted water being followed to flow into a stream.

Exercise 87. *To find the number of Bac. coli and allies by the "Gas" test.*

1. Melt a gelatine-tube and pour into it 2 drops of the sample under investigation.
2. Incubate at room-temperature.

It has been stated that a water should be 'passed' for non-drinking purposes if two drops of it (= .1 c.c.) in melted nutrient gelatine does not result in gas formation after incubation. Note, however, that this experiment is not a crucial test and is only useful for purposes of confirmation.

### Houston's Provisional Standards.

The following standard was provisionally adopted by Dr. Houston in determining whether a polluted water should or should not be allowed to pass into open streams without further treatment. The polluted water was allowed to pass if it conformed to the following.

Total no. of bacteria.

- |   |                                      |
|---|--------------------------------------|
| 1. Gelatine at 20° C.                                 | Less 100,000 per c.c.                |
| 2. Agar at 37° C.                                     | " 10,000 " "                         |
| 3. <i>Bac. coli</i> .                                 | " than 1,000 per c.c.                |
| 4. <i>B. enteritidis sporogenes</i> }<br>"Gas" test } | Negative result<br>with 0.1 c.c.     |
| 5. Indol test   | } Negative result<br>with 0.001 c.c. |
| 6. Neutral-red broth test                             |                                      |
| 7. Bile salt broth test                               |                                      |
| 8. Litmus milk test                                   |                                      |

## CHAPTER XI.

Yeasts. Nutrient-media: Structure of Yeast: Gas-production: Examination of Gas: Alcohol Production: Pure Culture methods: Preparation of marked cover-glasses: Moist-chamber experiments: Fermentation of Sugars: Determination of efficiency of Yeasts: Preservation of Yeasts.

### The Yeasts.

The 'technical' student must become acquainted with Yeasts not only because Yeast-colonies often appear on his plates, but primarily because of their great importance in various industrial operations. We owe the foundations of the practical side of the study of Yeasts to the brilliant researches of Emil Chr. Hansen.

Exercise 88. *Nutrient-media for the cultivation of Yeasts.*

*Wort.* Obtain some wort from a brewery or distillery.

Filter and sterilise filtrate by placing in steam steriliser three times on three successive days.

*Wort-Gelatine*—using the wort thus prepared, a solid nutrient medium can be obtained by the addition of 10 per cent. of gelatine.

#### 2. *Yeast-Water.*

1. Add  $\frac{1}{2}$  kilogram of starch-free pressed Yeast to 2 litres of water.
2. Place in steam-steriliser for  $\frac{1}{2}$  hour.
3. Filter whilst still warm.
4. Place filtrate for  $\frac{1}{2}$  hour in steam steriliser.

Another  $\frac{1}{2}$  hour in the Steam steriliser after a 24 hours interval should result in a sterile medium but the resulting fluid is too concentrated to be used without dilution.

It is recommended that as much sterile water should be added to this stock solution as is sufficient to give the fluid a sherry colour.

### 3. *Flesh Water.*

500 grams flesh free from fat are allowed to soak in 1,000 c.c. water in a cold place or better in an ice chest. After 24 hours press out the fluid, boil it for  $\frac{1}{2}$  hour and then pass it through a very fine muslin.

To each 1,000 c.c. of flesh-water add 5 grams NaCl, and 10 grams peptone. Neutralise with Sodium Carbonate. Filter and steam-sterilise.

### 4. *Fruit juices.*

(a) 1. Dried Apples 1 kilogram.

2. Water 5 litres.

3. Tartaric Acid 20 grams.

Allow to stand for 24 hours, then press out the juice, filter and sterilise.

(b) Fresh fruits e. g. grapes, cherries, plums etc. can be used for making a fruit juice. Put in about 4 or 5 times as much water (volume) as fruit. Allow to stand in a cold place, press out the juice, filter and sterilise.

5. Yeast-water + 10% Saccharose.

Yeast-water + 10% Dextrose.

6. *Wort-Agar.* Prepare as directed for Wort Gelatine, only substitute for the Gelatine, 8 grams of Agar per 500 c.c. of Wort.

7. In addition to the above, solid media may be prepared from the Yeast-water, or from one of the fruit-juices. In each case the requisite amount of agar or gelatine must be added.

### Exercise 89. *Beer-wort Culture.*

1. Inoculate a Wort-tube with a particle of pressed Yeast or with a loopful of barm from a bakery.

2. Incubate at 30° C. (approx.)

3. Examine tube after 24 hours to see if its contents have become turbid.

### Structure and Development of Yeast.

Some idea of the structure and normal method of reproduction of Yeast cells will be given by a comparative examination of the different stages represented in Fig. 38.

All the phenomena of life, digestion, division, reproduction, excretion etc. are performed within the limits of a single cell, which is usually oval in shape; but it may elongate, and in some cases may even form a system of threads such as is shown in Fig. 38b, that is to say typical fungal hyphae may be formed. In the above experiment probably only oval cells will be seen and the student by the comparison of a large number of the cells will find all stages in the production of daughter cells from a parent cell by the process known as *Budding*. The small buds arise often from two or three points in a cell, and each very quickly attains a size equal to the cell which bore them. As they in turn also form new cells by the production of buds it is obvious that in a comparatively short time even in a test-tube culture there will be many millions of cells. It is the presence of multitudes of these cells which causes the turbidity in beer-wort.

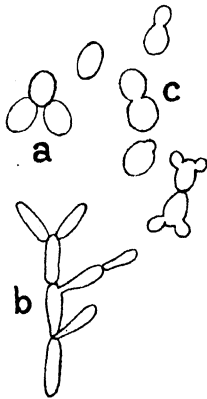

Fig. 38.— Various stages in the "budding" of Yeast cells. In **b** the cells show a tendency to form a system of threads. This is formed by the slight elongation of the cells and the adherence of the daughter- to the parent-cells.

Inside the cell are the *nucleus* and the *granules*. In addition one or more spaces, apparently but not really empty, are seen in each cell. Close attention should be given to the granules and spaces and the different ways in which these are disposed should be noted. Also a few drawings should be made of the varying shapes that different yeast cells assume.

#### Exercise 90. Wort-agar culture of Yeast.

1. Inoculate Wort-agar with a particle of pressed Yeast.
2. Incubate at 30° C.

3. When a surface growth has appeared on the agar, examine a portion microscopically, in a drop of water.

[Avoid putting too much Yeast-material in the drop of water. The latter should be barely visibly turbid after the Yeast-material has been added to it.]

Make drawings of a few of the Yeast cells, choosing for the purpose as many differently shaped cells as possible.

#### Exercise 91. *Preparation of Pasteur's Fluid.*

Place 75 grams of pressed Yeast in a vessel containing 1 litre of water, warm until the mixture boils, then allow it to boil for a further  $\frac{1}{4}$  hour. Filter. Filtrate should be pale yellow, make it up to one litre with water then sterilise in steam-steriliser, add 5—10 per cent. cane sugar.

#### Exercise 92. *Gas-production during Yeast-fermentation.*

1. Fit up apparatus shown in Fig. 39. The tube projecting into mouth of flask A, leads outside A into a gas collecting apparatus, composed of a fairly wide-tube full of water and inverted into a basin containing water. The test-tube is held by a clamp so that it can be raised about half an inch or more from the bottom of the basin. This is to allow the tube leading from A to pass into the basin and to be inserted under or slightly inside the collecting test-tube.

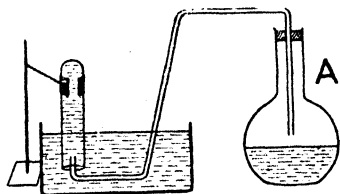

Fig. 39. — Diagrammatic representation of apparatus for collecting samples of gas evolved during Yeast-fermentation. For further explanation see Exercise 92.

2. Remove plug from A and pour in Pasteur's fluid until the flask is half full. [The end of the leading tube must be well above the surface of the Pasteur fluid, when it is replaced in position.]
3. Add a thimbleful of pressed Yeast to every  $\frac{1}{2}$  litre of Pasteur fluid.

4. Replace the stopper, make air-tight and put whole apparatus away in incubator at 30° C.
5. Examine after 24 hours. The test-tube will be full of a gas given off during the fermentation of Yeast in Pasteur's fluid.

Exercise 93. *Examination of gas given off during fermentation of Yeast.*

1. Collect some of the gas given off during the fermentation of Yeast in Pasteur's fluid (Exerc. 92) in a test-tube over water (Fig. 39).
2. By means of a curved pipette introduce a few c.c. of caustic potash solution. Note the rise of the water in the test-tube due to the absorption of the gas by the caustic potash.

This proves that the gas is carbon dioxide which is very soluble in caustic potash.\*

Exercise 94. *Production of alcohol in Yeast fermentation.*

Remove the cork from the flask in which Yeast-fermentation is going on (Exercise 92). A faint but distinct alcoholic odour is manifested.

**Test as follows (Klöcker Method).**

1. Place 5 c.c. of fermenting fluid in a vessel about 180 m.m. long and 24 m.m. diameter.
2. Warm slowly over a wire gauze by means of a gas flame taking care to prevent bumping. Characteristic oil drops accumulate in the glass tubing higher up or lower down according to the concentration of the alcohol.

**Pure Cultures of Yeast.**

The methods of pure culture which have been described for the isolation and cultivation of bacteria may be applied with equal success to the Yeast family.

Exercise 95. *Pure Culture of Yeast.*

1. Obtain a little distiller's or brewer's yeast or some barm from a baker.

---

\* The lime water test for this gas should also be applied.

2. Place a loopful in a sterile test-tube containing about 20 c.c. of sterile water, and make sure that the loopful is well distributed.
3. Prepare tubes of beer-wort gelatine by adding 5½ per cent. gelatine to beer-wort, and sterilising in the usual way, in the steam steriliser.
4. Melt the contents of one of these tubes and add a loopful from the Yeast-containing water.
5. Pour the contents of the tube into a sterilised Petri-dish. Allow to set then incubate at 20° C. or in a warm room.
6. Observe the colonies which develop on the gelatine. They will probably all conform to one or two types. Select one of the commonest kind and transfer a little of it to a drop of water on a slide. Examine microscopically.
7. If microscopic examination shows that that kind of colony is made up of Yeast cells, select one of a similar kind that is fairly large (not less than ½ m.m. in diam.), touch it with a sterilised needle and then dip the needle thus infected into a tube containing sterilised beer-wort, or any other sterile fluid or solid in which Yeast will grow.

The resulting growth is probably a pure culture as all the individuals making up the culture have probably been derived from a single cell.

#### Exercise 96. *Preparation of marked cover-glass.*

Before we can satisfactorily make a pure culture by the dilution method which is usually employed in the fermentation-industries it is necessary to prepare a cover-glass for the purpose by marking it off into little squares by an etching process.

1. Obtain a large square cover-slip and dip it for a moment by its edges into a crucible containing some melted paraffin-wax.
2. After the paraffin has set, with a ruler and fine needle,

draw lines parallel to the sides in such a way that 16 squares are ruled off in the paraffin-wax.

3. When done properly the coverslip is completely covered except where it has been exposed by the lines drawn by the needle.
4. Further, number each square from 1 to 16 and by writing a number inside each square with the needle.
5. Pour a little hydrofluoric acid over the part traversed by the needle. The acid bites into the glass where this is exposed.
6. Remove the acid after a minute or so and then melt the paraffin-wax.

1	2	3	4
5	6	7	8
9	10	11	12
13	14	15	16

The coverslip should now show etched lines and figures where the acid has come into contact with the glass (Fig 40).

Fig. 40.—For explanation see text.

#### Exercise 97. *Pure Culture by the Dilution Method.*

1. Sterilise 6 test-tubes (plugged with cotton wool) and place in each roughly 10 c.c. of sterile water. Place them in a test-tube rack.
2. Place  $\frac{1}{2}$  gram pressed Yeast in the first tube in the row and by thorough shaking and stirring make sure the Yeast and water have become thoroughly mixed.
3. Examine a loopful under the microscope. Observe that the Yeast cells are very closely packed together.
4. Remove a loopful from No. 1 tube and insert into tube No. 2 on the rack. Shake thoroughly to ensure a good mixture.
5. Examine a loopful under the microscope and this time instead of using an ordinary coverslip, use one prepared according to the directions given in Exercise 96. You will probably find that there are still many in the microscope field.
6. Transfer a loopful from No. 2 tube to No. 3 tube. See that the loopful is thoroughly mixed with the water in No. 3 tube.

7. Examine a loopful from No. 3 tube under the microscope, using the etched cover slip and this time examine the water systematically by bringing each square in turn under examination. [The object of dividing the cover-slip into squares is to enable the whole drop which is under the coverslip to be systematically searched.]
8. If more than one cell is found in this loopful still another dilution must be made until some certainty is reached that a loopful taken from the fluid contains either no yeasts or only one.

When this is the case, set 12—24 tubes\* containing beer-wort in a row and inoculate each with a loopful from the fluid diluted as described. The chances are then very great that when development takes place in any one of these, all the organisms in that particular tube have been derived from a single organism. The culture is therefore pure.

Exercise 98. *Pure Culture of Yeast* (Lindner Method).

1. Carry on the same procedure as in the preceding exercise until it is found that there is approximately one Yeast to one drop of the fluid.
2. With a sterile fine-bored pipette withdraw a portion of the fluid diluted to this extent and place droplets on the floor of a sterile Petri-dish. It is probable each drop will contain only one Yeast cell.
3. Each drop that contains a cell will develop into a colony after incubation (20° C.).
4. Touch a drop in which growth has taken place with a platinum needle and with this infect a tube containing a sterile nutrient medium.

The probabilities are very great that the resulting growth will be a pure culture.

Exercise 99. *Moist chamber Experiment*.

1. Melt a small quantity of beer-wort gelatine and mix with a drop or two of a fluid containing healthy Yeast

---

\* Hansen's flasks for culturing Yeasts will be found very convenient for this purpose (see Fig. 9e).

cells. The quantity of each must be so arranged that when a drop is examined under the microscope there will not be more than a dozen Yeast cells present altogether in the field.

2. Place on the marked overslip (See Exercise 96) a loopful of this mixture and spread it over the surface of the coverslip so as to make the film as thin as possible.
3. Allow the film to set and then place it film downwards on the moist chamber (Fig. 41). Before putting down the coverslip place a drop of water in the chamber and after putting it down, ring the edge of the coverslip with some substance that will prevent the film from losing much water.



Fig. 41.—Coverslip resting on shallow circular hole scooped out of substance of glass slide. When the coverslip rests on this hole, the latter is completely enclosed. As a drop of water is usually placed in the hole before the coverslip is laid on top of it an air tight *moist* chamber is formed if the edge of the coverslip, previous to insertion has been greased with some substance like vaseline.

4. Examine under the microscope. In the notebook make a drawing of the coverslip with its squares and figures, and indicate in this drawing where each Yeast cell is placed. See Fig. 40.
5. Incubate at 20° C. Examine each day. The chart will indicate the square in which each cell is placed.

“Visit” each cell in turn and note the progress, if any, which has taken place in its growth.

*Note.* In place of the hollowed-out slide, an ordinary slide may be used, and a small glass ring attached to it by



Fig. 42.—For explanation see text.

means of vaseline (Fig. 42). The squared coverslip may then be dropped on the top side of the ring and similarly fastened to it by smearing the top edge of the ring with vaseline.

*Exercise 100. The fermentation of sugars by Yeasts.*

The student is advised to read the Exercises 36—40 in which the fermentation of sugars by bacteria is discussed. By using Yeast-water as the nutrient fluid and adding various sugars to this liquid it is evident that the same methods will serve for Yeasts as enabled us to determine whether certain bacteria fermented certain sugars.

*Exercise 101. To determine the efficiency of Yeast.*

The efficiency of Yeast may be estimated by the activity of the fermentation which it sets up. We may therefore either estimate the amount of alcohol formed or the amount of  $\text{CO}_2$  liberated during fermentation. The latter is by far the simpler. The Meissl Ventilation Valve when fitted to a flask allows the  $\text{CO}_2$  to escape but retains the water that is given off in the form of vapour (see Fig. 43). It is obvious that the loss in weight of the apparatus indicates the amount of  $\text{CO}_2$  that has been liberated during the progress of the experiment. The amount of  $\text{CO}_2$  liberated may be taken as the measure of the efficiency of the Yeast, although it must be pointed out that the correlation between gas liberation and efficiency of Yeast is not complete and for accurate work other factors which affect the efficiency of Yeast should be taken into account.



Fig. 43.—Meissl Ventilation Valve. Apparatus for permitting the  $\text{CO}_2$  given off in Yeast-fermentation to escape. The water, however, which is given off in the form of vapour is retained.

1. In the flask place  $\frac{1}{2}$  gramme of pressed Yeast and 50 c.c. of Pasteur's fluid (Exercise 92).
2. Into the valve place a small amount of concentrated sulphuric acid to absorb the moisture.

3. Weigh the apparatus, then set aside at a temperature of  $20^{\circ}$  C.
4. Weigh from time to time and draw a curve showing the loss of  $\text{CO}_2$  after each fixed interval of time.

Exercise 102. *The preservation of Yeasts.*

1. Prepare the following medium  
Cane sugar 100 c.c. of 10 per cent. solution,  
Sulphuric acid .1 gram.
2. Sterilise.

Yeasts may be preserved for years in this medium. Care must be taken that the preserving bottle is carefully stoppered up. Hansen's flask (Fig. 9 e) serves the purpose very well. The outlets are carefully plugged first with cotton-wool and then with sealing wax over the cotton-wool.

## CHAPTER XII.

### MOULDS.

Examination of impure Mucor: Examination of impure Penicillium: Germination of spores: Methods of spore-location: Pure culture of Mucor mucedo: Culture-media for Fungi: Identification of commoner Moulds: Acidity-changes produced by moulds: Infection of fruit with mould.

### Moulds.

The term mould is not given to any particular group of Fungi but is rather a popular term to indicate different fungi which externally are very much alike especially to those who have not made a special study of these organisms. All 'fluffy' growths are usually called moulds. On culture media moulds form colonies that are made up of very tiny threads called hyphae and under the low power of the microscope these hyphae are seen to branch and anastomose. The colony is thus easily distinguished from those that are formed by bacteria or by yeasts.

The student should study a single species of mould with the same care and essentially in the same manner as was necessary in the study of bacteria and yeasts.

Moulds form spores as do the bacteria: in fact the identification of the different species largely depends on the mode of formation of these reproductive bodies.

In the majority of cases the student will find that a species which appears on his cultures is either a Mucor or a Penicillium. The former is distinguished by the formation of spores inside a receptacle called a sporangium (Fig. 44). Usually the membrane of the sporangium bursts

during the operation of preparing a slide for microscopic observation and the sporangium appears as is shown in Fig. 45. The spores of *Penicillium* on the other hand arise in chains from the ends of short branches (Fig. 46). The two genera are thus easily distinguished. Further the spores of

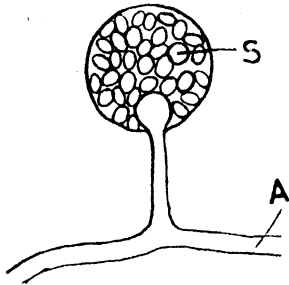

Fig. 44. — Diagrammatic representation of the sporangium of *Mucor*. A = Fungal thread from which arises the branch which in its turn forms the globular head. S = Spores inside the globular head.



Fig. 45. — For explanation see text.

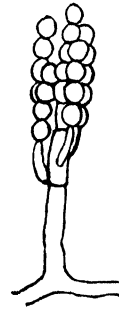

Fig. 46. — *Penicillium*. The fungal threads give rise to a cluster of short branches, from the end of each of which a row of spores is formed.

*Penicillium* are green in colour so that they impart a green or blue colour to the culture in which they appear, for their production is usually in enormous numbers. Thus it may be estimated that a 2 lb pot of jam which is covered on its surface with a green mould, owes its greenness to the cumulative effect of 36 million green spores. Another important method of distinguishing these two genera is furnished by the fact that the hyphae of *Penicillium* possess transverse walls which are absent from the hyphae of *Mucor* except immediately underneath each sporangium.

Exercise 103. *Examination of a white mould* (probably an impure culture of *Mucor*) *which has appeared in the cultures.*

1. Mount a small portion of the fluffy material on a glass slide and examine microscopically. Observe
  - (a) The hyphae which branch freely.
  - (b) The absence of transverse walls.

- (c) The spores, which are enclosed in a sporangium (see Figs 44, 45). Compare their size with that of the spores of bacteria and of the Yeast cell.

Exercise 104. *Examination of a green mould.*

1. Examine in the same way as in the preceding exercise. Observe
  - (a) The hyphae which form numerous branches.
  - (b) The presence of transverse walls.
  - (c) The spores, which arise in small clusters of chains. The hyphae in each cluster which give rise to the spores arise all from a small upright hypha which is attached to the main body of the hyphae.

Exercise 105. *Germination of Mould-spores.*

1. Construct a germination-chamber in the manner indicated in Exercise 99, using for preference the glass-ring described in the note attached to that exercise (see Fig. 47).
2. Examine a Mould-culture to see if spores are developed in abundance.
3. If spores are present in abundance, rub a sterile moistened Plat. loop in the mass of the mould so that when withdrawn it cannot fail to remove with it a number of spores.
4. Place a drop of melted wort-gelatine on a cover-slip: the latter must be large enough to cover the glass-ring.
5. Rub the Plat. loop in the wort-gelatine so that some of the spores are transferred from the loop to the wort-gelatine.
6. With a sterilised Plat. loop rub the wort-gelatine over the surface of the coverslip until it sets in the form of a film.
7. Place a drop of water at the bottom of the glass-ring, on the slide, then close up the cavity formed by the glass-ring by placing the coverslip on top of it. In doing so, take care that the film side of the cover-slip is on the under-side.

8. Make the cover-slip secure to the glass-ring in the same way that the glass-ring was made secure to the glass slide. The whole apparatus will now be made up as is shown in Fig. 42.
9. Examine film under microscope and locate a few spores so that they can be found again in the same way as was done for the yeasts. Place the apparatus, well covered in a warm room, preferably in the dark and examine daily. The course of germination can be followed by a daily examination of the spores. It will be noticed that all the conditions necessary before germination can take place have been satisfied.
  1. Presence of food in the wort-gelatine.
  2. Presence of air.
  3. A sufficiency of moisture.
  4. Absence of substances that can hinder growth.
  5. Adequate temperature.

*Note. The Location of Spores.*

It is necessary that the same spore or set of spores should be examined day after day in order to follow the stages of germination.

Method I.

The writer can recommend a very simple method which he has devised and found very successful.

1. Focus the slide with a low-powered objective. The spores are very small but are distinctly visible. Select the spore that it is desired should be under daily observation. [Care should be taken that there are not too many spores on the slide.]
2. With a fine pointed pen draw a circle with Indian-ink around the selected spore. To do this focus the spore, then bring the pen within the field of vision so that the eye sees within the microscope both the spore and the tip of the pen. The tip can thus be moved so as to draw a black circle round the spore. Of course we can return

to the spore any time by focussing within the black circle when the spore will be found without trouble.

3. Draw about  $\frac{1}{2}$  dozen of these circles on the cover-slip, each one of course circling a spore which it is desired to investigate.

If any difficulty is experienced in making circles that are not splotchy on the glass, the difficulty can be remedied by taking precautions to make the upper side of the cover-slip absolutely clean and dry.

Method II for location of spores.

Instead of using an ordinary coverslip for the experiment, the squared slide may be employed (See Exercise 96).

### Note on *Mucor mucedo*.

The spores inside the sporangia are *asexual* and correspond to those spores of *Penicillium* that are normally so abundantly formed. Like *Penicillium* *Mucor* also forms *sexual spores* but for our purpose their importance is not great. The fact must be noted with care that whilst the asexual spores of *Mucor* are formed *inside* a spore-box or sporangium, the similar spores of *Penicillium* are formed by abstriction from the ends of hyphae.

Exercise 106. *To make a pure culture of Mucor mucedo.*

1. Into a sterile small test-tube pour about an inch of sterile water.
2. With a sterilised Plat. loop pick up a tiny portion of the *Mucor* culture and mix this material with the water in the test-tube.
3. Sterilise loop and lay it on the rest.
4. Melt a tube containing the nutrient medium the preparation of which is described in Exercise 107, Section A.
5. Pick up loop and sterilise it.
6. With loop remove a loopful of infected water from test-tube.
7. Add this to melted nutrient medium.

8. Shake thoroughly—but gently—to establish a good distribution of the infected water.
9. Pour contents into sterile Petri-dish.
10. Set aside, well covered, at room temperature until colonies appear.
11. When colonies have appeared, touch one which is well apart from the other colonies with a sterilised Plat. needle.
12. Then stab this Platinum needle into a tube containing the same nutrient medium as was used above for Petri-dish culture.

Exercise 107. *Media for cultivation of Fungi.*

A. *Maltose-peptone Agar.*

Maltose . . . . .	4 grams
Peptone . . . . .	1 gram
Agar . . . . .	1.5 grams
Water . . . . .	100 c.c.
Normal hydrochloric acid	2 c.c.

B. *Maltose-peptone broth.*

Same as A but with the omission of Agar.

C. *Plum-gelatine.*

Boil 100 grams of dried plums in 100 c.c. water. Make up to 200 c.c. then add 20 grams gelatine.

D. *Bread-mash.*

Add enough water to dry crumbled bread to make a mash. Sterilise in steam steriliser.

E. *Rice mash.*

Rice meal . . . . .	10 grams
milk . . . . .	15 c.c.
maltose-peptone broth (B)	

F. *Beer-wort Agar.*

Beer-wort . . . . .	100 c.c.
Agar . . . . .	1½ grams.

**Identification of the Commoner Moulds.**

*Mucor mucedo*—Found in excreta of herbivorous animals, particularly in horse-excreta. Sporangia as in Fig. 44.

*Mucor racemosus.*

Found in bread and decaying vegetable matter.

Identified by the shape and appearance of the brownish sporangia (See Fig. 47).

*Mucor Rouxii* (Amylomyces).

Forms a yellow covering on rice. Used commercially for the conversion of starch into sugar.

The sporangia are spherical and possess ellipsoid spores.

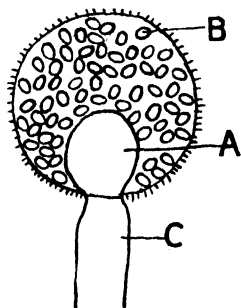

Fig. 47.—Sporangium of *Mucor racemosus*.

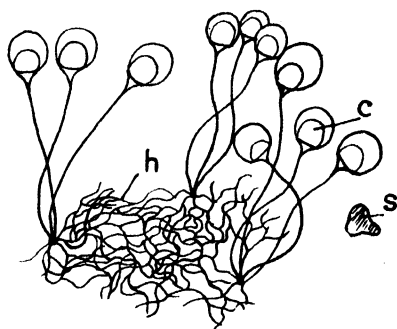

Fig. 48.—Sporangia of *Rhizopus*.

*Rhizopus nigricans* (Fig. 48).

Found on a great variety of juicy fruits. Recognized by disposition of the sporangia. These are found in clusters, each cluster being made up of a number of sporangia the stalks of which originate from one point. The spores are also somewhat angular.

*Monilia candida*. White layer covering fresh cow-dung.

Grows like Yeast-cells in Wort, finally forming a typical fungal mycelium.

*Oidium lactis*. The Milk Mould.

Thick white felt. Hyphae transparent, thin-walled and often forked. Spores are rectangular in longitudinal section (Fig. 49).

*Fusarium*—Cause of red colour which sometimes occurs on malt grains.

*Chalara mycoderma*—Forms a film on liquids. Hyphae of unequal size and varying in width even in the same thread. Small reproductive cells called 'conidia' are regularly formed at the ends of threads (Fig. 50);

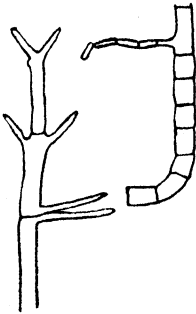

Fig. 49.—*Oidium lactis*.

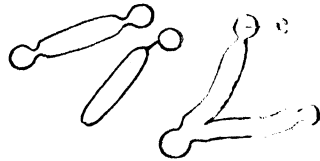

Fig. 50.—*Chalara mycoderma*.

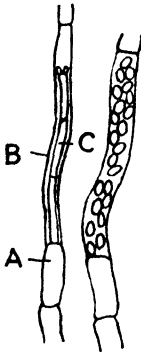

Fig. 51.—*Dematium pullulans*. Threads often grow through other threads. Thread C is shown growing inside thread B, having arisen as a branch from the cell A.

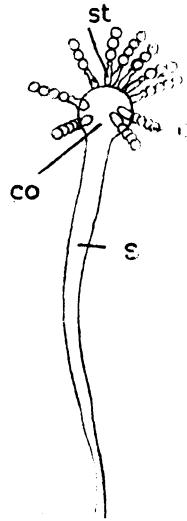

Fig. 52.—*Aspergillus*. S—branch from fungal thread which expands at the top to form the globular head (CO). From the latter short branches are formed (St). From each of these a row of spores (C) is developed.

*Dematium pullulans* Found on grapes and other fruits. Branched mycelium Buds formed from mycelium. Buds formed from mycelium. Threads often grow through other threads (Fig. 51), at the ends of threads growing inside other cells. conidia are formed.

*Aspergillus* (including genus *Eurotium*).

Hyphae possess transverse septa, spores given off at ends of short rods (called sterigmata). Sterigmata develop on a terminal globular swelling (Fig. 52).

*Penicillium*.

Hyphae possess transverse septa spores arise in a cluster of short chains, each chain forming the end of a short rod.

### Acidity changes produced by Moulds.

The development of acidity in a nutrient medium effects profound changes in the micro-organismal life of that medium. As the nature of the end-products varies with the kind of micro-organism that holds sway in the fluid, and as the acidity controls the micro-organism it is evident that many processes in industry may be accelerated or retarded by following the rise or fall of the acidity during the period of growth and neutralising or accentuating its effect according to the nature of the circumstances.

Exercise 107. *Estimation of change in acidity caused by the development of Mould.*

1. Boil a few prunes in hot water and estimate the acid content by titration with  $\frac{1}{10}$  normal NaOH.
2. Pour about 50 c.c. of the prune juice into a sterilised flask and inoculate with the mould under examination.
3. After 3 days titrate again and find out whether the acidity has increased or decreased during the progress of the growth of the mould.

*Method of titration.*

1. Place in a flask 1 c.c. of the prune juice and dilute to 50 c.c.
2. Add a drop of Phenolphthalein.
3. Neutralise with  $\frac{N}{10}$  NaOH. The mixture is neutral when it just begins to turn red.

Suppose  $\frac{1}{6}$  c.c. of  $\frac{N}{10}$  NaOH was necessary for neutralisation.

Hence  $\frac{1}{6}$  c.c. of  $\frac{N}{10}$  NaOH neutralises 1 c.c. prune juice.

$$\begin{aligned} \text{Hence } 100 \text{ c.c. would require } & \frac{100}{6} \cdot \frac{N}{10} \text{ NaOH} \\ & = \frac{10}{6} \cdot \frac{N}{1} \text{ NaOH.} \end{aligned}$$

If 1000 c.c.  $\frac{N}{1}$  NaOH = 36.5 grams HCl

Then 1 " " requires .0365 gram HCl

"  $\frac{10}{6}$  " " .061 " "

Hence acidity = .061 % HCl.

If experiments are made with other moulds, care must be taken that the conditions are the same throughout the whole series of experiments. Place the nutrient medium in the same kind of flask, incubate at the same temperature, and employ the same volume of nutrient fluid in each case.

#### Exercise 108. *Infection of fruit with a Mould.*

1. Clean the surfaces of a tomato, a grape and a plum.
2. Place each in a deep sterile Petri-dish.
3. Pour a thin layer of water on bottom of each Petri-dish.
4. Lift a tiny bit of a mould with a needle and stab with it each of the three fruits.
5. Set aside preferably in a warm place under a suitable covering.
6. Examine after a few days and ascertain whether the hyphae and spores that have developed are identical in shape, size etc. with the mould with which the fruits were infected.

## APPENDIX.

*Note 1.* When pouring the contents of a test-tube into a Petri-dish, it is important that the operation should be performed in such a way that the liquid is exposed to the atmosphere for as short a time as possible. The diagram in Fig. 53 shows how this may be accomplished. As soon as the stopper is removed from the test-tube, the lid of the Petri-dish is raised as shown in the diagram, the test-tube inserted under the raised lid, the liquid poured into the dish, and the Petri-dish cover closed immediately.

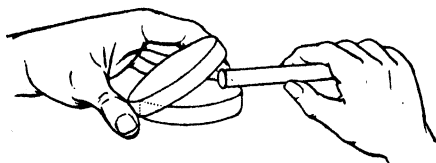

Fig. 53.

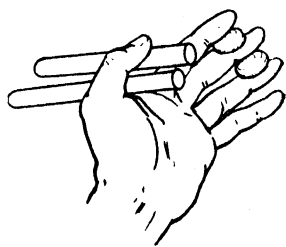

Fig. 54.

*Note 2.* In transferring material from one test-tube to another, it is not advisable to lay the stoppers on the surface of the table, for fear of contamination. When the tube-end of the stopper is only in contact with the air the risk of contamination is much less than if it lay on the table. In Fig. 54 is shown one way of holding two test-tubes with the left hand, and at the same time allowing the fingers freedom to hold the two cotton-wool stoppers which have

been removed from the test-tubes. Obviously the right hand must be used exclusively for holding the inoculating instrument.

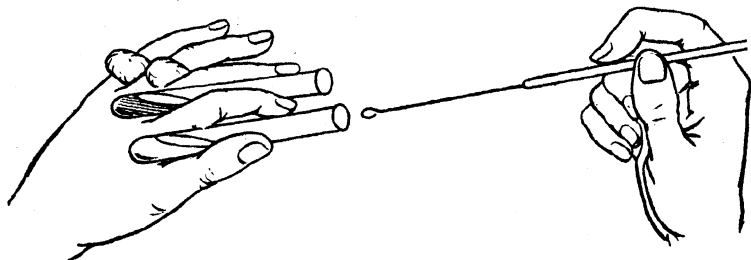

Fig. 55.

*Note 3.* Fig. 55 illustrates another method of accomplishing the process of inoculation without the necessity of placing the cotton-wool stoppers on the table.

## INDEX.

### A.

- Acid-production in Bacteria, 58  
Acidity changes produced by moulds, 125  
Acidity, development in broth culture 60  
Agar, note on, 17  
— -plate culture, examination of, 25  
— -plates, preparation of, 23  
— preparation of nutrient-, 17  
— -slope culture, examination of, 27  
— -slope, preparation of, 24  
— -tubes, preparation of, for gas testing, 55  
Alcohol, 8  
Alcohol, Klöcker test for, in yeast fermentation, 110  
—, production of, in yeast fermentation, 110  
Amylomyces, 123  
Anaerobes, 63  
Anaerobic bacteria, apparatus for cultivation of, 67, 68, 69  
— —, method of plating, 65  
— —, searching for, 64  
— — cultivation, 63, 66, 67, 68  
Aniline Dyes, use of, in staining bacteria, 34  
— Gentian Violet, 35  
Apparatus, bacteriological, 1 et seq.  
— for cultivation of anaerobic bacteria, 67—69  
— — sterilisation and protection of Petri-dishes, special, 6  
Ellis' Practical Bacteriology.

- Art of staining bacteria, 35  
Aspergillus, 125  
Autoclave, 2

### B.

- Bac. acidi lactici, 56  
— alvei, 53  
— asterosporus, 53  
— butyricus, 93  
— cadaveris, 93  
— carotarum, 53  
— cohaerens, 53  
— coli communis, 56, 87.  
— — —, distinguishing characters, 87  
— — —, estimation of number of, by litmus milk cultures, 104  
— — —. identification of, 88  
— — —, search for, 90  
— enteritidis sporogenes, search for, 93  
— megatherium, 23, 24, 28, 29, 48, 50, 76  
— kiliense, 56  
— simplex, 53  
— subtilis, 53  
— typhosus, 46  
— vulgare, 56  
Bacteria, acid-producing, 58  
—, art of staining, 35  
—, chromogenic, 85  
—, cultivation of anaerobic, 63—68  
—, estimation of size of, 69  
—, Gas producing, 55

Bacteria, Iron, 53  
 —, isolation of 78  
 —, staining of, 8  
 —, use of aniline dyes in staining, 34  
 Bacterial growth, external features of, 27  
 — —, microscopic examination of, 30  
 Bacteriological apparatus, 1 et seq.  
 Balsam, Canada, 8, 37  
 Beakers, 6  
 Beginners, Hints to, 8 et seq.  
 Beer-wort agar, preparation, — culture, 107  
 Bottles, drop, 8, 12  
 Blood corpuscle, size of, 74  
 Bile salt broth, M<sup>c</sup> Conkey and Hill's, 89  
 — — lactose agar, M<sup>c</sup> Conkey's, 89  
 Bread mash, preparation of, 122  
 Broth culture, examination of, 31  
 — —, preparation of, 29  
 —, preparation of nutrient, 16  
 — cultures, Gas production in, 56  
 — —, development of acidity in, 60  
 Brownian movement, 27  
 'Budding', 108  
 Bulloch jar, 65

## C.

Cages, wire, 6  
 Camera lucida, 72  
 Canada Balsam, 8, 37  
 Capsule, 50  
 — staining, 50  
 Cedar-wood oil, 8  
 Cell, vegetative, 20, 21  
 Chalara mycoderma, 124  
 Change 'Enteritidis', 101  
 Chromogenic bacteria, 85

Choice of temperature for cultivation of organisms, 5, 6  
 Cilia, 27  
 — staining of, 45, 46  
 Coccaceae, 80  
 Colonies, 25  
 —, bac. coli, recognition of, 98  
 —, counting of, 80, 82  
 —, examination of gelatine plate, 28  
 —, internal structure of, 26  
 —, outline of, 25  
 Common moulds, identification of, 122  
 Conidia, 124  
 Contact preparation, 51  
 Counting of Colonies, 80  
 Coverslips, 6  
 —, receptacles for, 6, 11  
 Cotton-wool plugs, notes on the making of, 19  
 Cultivation of organisms, choice of temperature for, 5, 6  
 — — bacteria in gas producing media, 56  
 — under anaerobic conditions 63, 66, 67, 68  
 Cultures, examination of agar-plate, 25  
 Culture, examination of agar-slope, 27  
 —, examination of broth, 31  
 —, — — gelatine stab, 30  
 —, milk, 62, 76  
 —, preparation of a broth, 29  
 —, pure, 79

## D.

Dematium pullulans, 124  
 Development of Yeast, 107  
 Dilution, Houston's method of, 95  
 — method, pure cultures by, 112  
 — of Sewage, 95  
 Drinking water, 86

Drop-bottles, 8, 12  
 Drop preparation, hanging, 40  
 Dry-film staining, 36, irrigation  
 method, 40  
 Durham fermentation tube, 6,  
 9, 56  
 Dusters, 8  
 Dyes in staining bacteria, use  
 of, 34

**E.**

Efficiency of yeast, to deter-  
 mine, 115  
 'Enteritidis' Change, 101  
 Erlenmeyer flasks, 6, 9  
 Estimation of bac. coli by  
 litmus-milk culture, 104, of  
 bac. coli in sewage effluents,  
 98, of change of acidity  
 due to mould, 125, of rate  
 of movement of bacteria,  
 83, of size of bacteria, 69  
 et seq  
 Eurotium, 125  
 Evolution of sulphuretted  
 hydrogen, 15  
 Examination of bacterial  
 growth, 30, of agar-plate  
 cultures, 25, of agar-slope  
 cultures, 27, of broth cul-  
 ture, 31, of gelatine-plate  
 colonies, 28, of green mould,  
 microscopic, 25, 36, of sew-  
 age for Bac. enteritidis  
 sporogenes, 100, of shake  
 culture, 30, of stab culture,  
 30, of white mould, 118,  
 of gas given off during  
 yeast fermentation, 110  
 External features of bacterial  
 growth, 27  
 Extract, flesh, 14

**F.**

Fat-globules, staining of, 54  
 — — and spores, to distin-  
 guish between, 54

Fermentation, examination of  
 gas given off during yeast,  
 110  
 —, gas production during yeast,  
 109  
 — of sugars by yeast, 115  
 — tubes, Cultivation of gas-  
 forming organisms in  
 Smith's, 57  
 — —, Smith's, and Durham's,  
 6, 9  
 Flagella, staining of, 45, 46  
 Flasks, Erlenmeyer, 6, 9  
 —, Hansen, 6, 11  
 Flesh extract, 14  
 — water, 106  
 Foecal contamination, to test  
 street mud for, 101  
 Food materials, reserve, 52  
 Fruit, infection with moulds,  
 126  
 — juices, 107  
 Fuchsine, 35  
 Fungi, media for cultivation  
 of, 122  
 Fusarium, 123

**G.**

Gas producing media, culti-  
 vation of bacteria in, 56  
 — production by bacteria, 55  
 — — in broth cultures, 56  
 — — during yeast fermenta-  
 tion, 109  
 — given off during yeast fer-  
 mentation, examination of,  
 110  
 — forming organisms, culti-  
 vation in Smith's fermenta-  
 tion tube, 57  
 — testing, preparation of agar  
 tubes for, 55  
 — valve regulator, 4, 5  
 Gelatine liquefying bacteria,  
 counting, 94  
 — note on, 15

- Gelatine, preparation of nutrient-, 14  
 — — of plates, 24  
 — -plate colonies, examination of, 28  
 — -stab, preparation of, 28  
 — -shake, preparation of, 29  
 — culture, examination of, 31  
 — -stab culture, examination of, 30

- Gentian violet, aniline, 35  
 Germination of spores, 48  
 — — mould-spores, 119

- Glass pencil, 8  
 — rods, 8  
 — pipettes, 6  
 — slides, 6  
 — —, receptacles for, 6, 11  
 — tumblers, 8

- Globules, Oil, 53  
 —, staining of fat, 54  
 Glycerine-potato, growth on, 85  
 Glycogen, 53  
 —, to demonstrate presence of, 53

- Graduated Pipettes, 6  
 Gram staining, 41  
 Granules, 108  
 Green mould, examination of, 119  
 Growth, external features of bacterial, 27  
 —, microscopic examination of bacterial, 28

**H.**

- Hanging-drop preparation, 40  
 Hansen flasks, 6, 11  
 Hints to beginners, 8 et. seq.  
 Holder, petri-dish, 7  
 Horn spoon, 8  
 Hot-air oven, 2  
 Houston's dilution, 95  
 — provisional standards, 105

**I.**

- Incubator, 3  
 Independent movement, 27

- Individual organisms, shape of, 27

- Indol production, 61  
 —, test for, 61, 62  
 — forming bacteria in sewage, 99  
 — Infection of fruit with mould, 126

- Identification of spores, 42  
 — — bac. coli communis, 88  
 — — commoner moulds, 122  
 Internal structure of colonies, 26

- Iodine, 35  
 Iron bacteria, 53  
 Irrigation dry-film method of staining, 38  
 Isolation of bacteria, 78, from soil, 78, from air, 80, from hay-infusion, 79

**J.**

- Juices, fruit, 107

**K.**

- Klöcker test for alcohol in yeast fermentation, 110

**L.**

- Labels, 8  
 Lindner method for pure yeast cultures, 113  
 Litmus milk, 76  
 — — cultures, to count bac. coli by, 104  
 — paper, 8  
 Location of Spores, 120  
 Loeffler's Methylene blue, 35  
 Loop, platinum, 6, 9

**M.**

- Maltose-peptone agar, preparation of, 122  
 — — broth, preparation of, 122

Marked cover glass, 111  
 M<sup>c</sup> Conkey's Bile-salt lactose-  
 agar, 89  
 — and Hill's Bile-salt broth,  
 89  
 M<sup>c</sup> Crorie's night blue stain, 47  
 Media, cultivation of bacteria  
 in gas producing, 56  
 — for cultivation of fungi, 122  
 —, preparation of nutrient, 14  
 — method of sterilisation, Tyn-  
 dall's, 21  
 Methylene blue, 35, Loeffler's,  
 35  
 Micrometer slide, 71  
 Microscope, 8  
 Microscopic examination, 25,  
 26, of bacterial growth, 30  
 Milk cultures, 62, 76  
 —, preparation of litmus-, 76  
 —, culture of bac. meg. in  
 litmus, 76  
 — mould, 123  
 Mode of sterilisation, note on  
 selection of, 20  
 Moist chamber experiment,  
 113  
 Molecular movement, 27  
*Monida candida*, 123  
 Moore's method, cultivation  
 of anaerobic bacteria by, 68  
 Motility, 27  
 Moulds, 117  
 —, *aspergillus*, 125, *chalara*  
*mycoderma*, 124, *dematium*  
*pullulans*, 124, *eurotium*,  
 125, *fusarium*, 123, milk  
 mould, 123, *monida candida*,  
 123, *mucor mucedo*, 122,  
*mucor racemosus* 123, *mu-*  
*cor rouxii*, 123, *oidium lac-*  
*tis*, 123, *penicillium*, 125,  
*rhizopus nigricans*, 123  
 Mould, examination of white,  
 118, of green, 119  
 —, infection of fruit with, 126  
 — family, 80

Mould-spores, germination of,  
 119  
 Moulds, acidity changes pro-  
 duced by, 125  
 —, identification of commoner,  
 122  
 Movement, Brownian or mole-  
 cular, 27, independent, 27,  
 of bacteria, estimation of  
 rate of, 83  
*Mucor*, 117  
 — *mucedo*, note on, 121, to  
 prepare a culture of, 121

## N.

Needle, platinum, 6, 9  
 Neutral red broth, preparation,  
 103  
 Night blue stain, M<sup>c</sup> Crorie's,  
 47  
 Non-motility, 27  
 Normal solution, standard, 59  
 Note on agar, 17, on making  
 cotton-wool plugs, 19, on  
 selection of mode of sterili-  
 sation, 20, on storage of  
 nutrient broth, 17  
 Nucleus, 108  
 Nutrient agar, preparation, 17  
 — broth, note on storage of,  
 17  
 — —, preparation, 16  
 — gelatine, preparation, 14  
 — media, preparation, 14,  
 method of transferring into  
 tubes, 19, for yeast cul-  
 tures, 106

## O.

*Oidium lactis*, 123  
 Oil, cedar-wood, 8  
 — -globules, 53  
 Organisms, choice of tempera-  
 ture for cultivation of, 5,  
 6, shape of individual, 27  
 Outline of colonies, 25

Oven, hot-air, 2  
Oxygen, removal of, 63

## P.

Pair of pincers, 8, scissors, 8  
Pasteur's fluid, preparation of, 109  
Penicillium, 117, 125  
Petri-dishes, 6, 9, counting colonies on, 80, 82, holder, 7, special apparatus for sterilization and protection of, 6  
Pincers, pair of, 8  
Pipettes, graduated, 6  
Plate colonies, examination of gelatine, 28  
Plates, preparation of agar-, 23, of gelatine-, 24  
Plating anaerobic bacteria, 65  
Platinum loop, 6, 9  
— needle, 6, 9  
— needle and loop, rest for, 8, 12  
Plugs, note on making of cotton-wool, 19  
Plum gelatine, 122  
Potato, growth on glycerine-, 85  
Preparation of agar, 17, agar-plates, 23, agar-slope, 24, agar tubes for gas testing, 55, beer-wort agar, 122, beer-wort culture, 107, broth, 16, broth culture, 29, bread-mash, 122, flesh-water, 106, fruit-juices, 107, gelatine, 14, gelatine-plate, 24, gelatine-stab, 28, gelatine-shake, 29, hanging drop, 40, litmus milk, 76, M<sup>c</sup> Conkey's bile-salt lactose agar, 89, M<sup>c</sup> Conkey and Hill's bile-salt broth, 89, marked cover glass, 111, maltose-peptone agar, 122, maltose-peptone broth, 122, mucor

mucedo, 121, neutral red broth, 103, Pasteur's fluid, 109, plum gelatine, 122, rice mash, 122, Toisson's fluid, 74, stains, 35, wort, 106, wort-gelatine, 196, yeast water, 106

Preparation by contact, 51

Preservation of yeast, 110

Production of alcohol in yeast fermentation, 110, of acid by bacteria, 58, of gas by bacteria, 55, of indol by bacteria, 61

Provisional standards, Houston's, 105

Pure culture, 79, of yeast by dilution method, 112, by Lindner's method, 113, of yeast, 110

## R.

Rate of movement of bacteria, estimation of, 83

Receptacle for glass-slides and coverslips, 6, 11, sterilized test-tubes, 8, 12.

Reserve food materials, 52

Rest for platinum needle and loop, 8, 12

Removal of oxygen, 63

Revision, 31, 76

Rhizopus nigricans, 123

Rice-mash, preparation, 122

## S.

Scissors, pair of, 8

Sewage and sewage effluents, 95

— dilution, 95

—, test for streptococci in, 102, total bacteria in, 96, 97

Sewage Effluents, estimation of bac. coli in, 98, examination for bac. enteritidis sporogenes, 106, test for

indol forming bacteria in, 99

Shake culture, examination of, 31, preparation of gelatine-, 29

Shape of individual organisms, 27

Size of bacteria, estimation of, 69, et seq. of human-blood corpuscle, 74

Slope, preparation of agar-, 24  
— culture, examination of agar-, 27

Smith's fermentation tube, 6, 9, 57

Solution, stock, 35, standard normal, 59

Spoon, horn, 8

Spores, 20, 21, 27, 43, germination of, 48, germination of mould-, 119, location of, 120, identification of, 42, staining, 43, 44, 45, distinction between fat-globules and, 54

Sporangium, 117, 118

Spirillum giganteum, 51, volutans, 51

Stab, preparation of gelatine-, 28, examination of culture, 30

Stain, preparation of, 35, M<sup>o</sup> Cricie's night-blue, 47

Staining bacteria, use of aniline dyes, 34, Art of, 35, dry-film, 36, Gram method, 41, wet, 37, irrigation dry film, 38, cilia, 45, 46, capsule, 50, fat-globules, 54, spores, 43—45.

Standard normal solution, 59  
—, Houston's provisional 105

Stock solution, 35

Steam sterilizer, 1

Sterilizer, steam, 1

Sterilization, and protection of petri-dishes 7

Sterilization, of test tubes, 18  
—, note on the selection of method, 21  
— Tyndall's method, 21

Storage of nutrient broth, note on, 16

Street-mud, test for foecal contamination in, 101

Streptococci, test for in sewage, 102

Structure of colonies, internal, 26, and development of yeast, 107

Sugars, fermentation of, by yeasts, 115

Sulphuretted hydrogen, evolution of, 75

## T.

Temperature, Choice of for cultivation of organisms, 5, 6, regulating apparatus. 5.

Test for alcohol in yeast fermentation, 110, for bac. coli in badly polluted water by neutral red broth, 103, for indol, 61

Test-tubes, 6, receptacles for sterilized, 8, 12, sterilization and washing of, 18

Toisson's fluid, 74

Total count of bacteria in water sample, 90

Tumblers, glass, 8

Tyndall method of sterilization, 21

## V.

Vegetative cell, 20, 21

Volutin, 52, to demonstrate presence of, 52

## W.

Water, drinking, 86  
—, total bacteria in sample, 90

Washing of test-tubes, 18

Wet staining, 37

White mould, examination of, 118

Wire cages, 6

Wort, 106, -gelatine, 106, -agar, 107, -agar cultivation of yeast, 108

**X.**

Xylol, 8

**Y.**

Yeasts, 106, nutrient media for cultivation of, 106, pure cultures, 110, Lindner method, 113, preservation of,

116, determination of efficiency, 115, fermentation of sugars by, 115, structure and development of, 107

Yeast fermentation, gas produced during, 109, examination of gas given off, 110, production of alcohol in, 110  
— wort-agar, culture of, 108  
— -water, 106

**Z.**

"Zeiss's Zeichnen Apparat", 72.



