

UNIVERSAL  
LIBRARY

**OU\_166252**

UNIVERSAL  
LIBRARY



OSMANIA UNIVERSITY LIBRARY

Call No. 170/534P

Accession No. 20341

Author Schlick, Moritz

Title Problems of Ethics.

This book should be returned on or before the date last marked below.



PLASTICS  
FOR  
INDUSTRIAL USE

*The quality of the materials used in the manufacture  
of this book is governed by continued postwar shortages.*

**PRODUCT DEVELOPMENT SERIES**

**TEXTS AND REFERENCE WORKS OUTLINED  
BY THE FOLLOWING COMMITTEE**

**K. H. CONDIT**, *Chairman and Consulting Editor*  
Dean, School of Engineering, Princeton University

**E. P. BULLARD**  
President of The Bullard Company.

**G. M. EATON**  
Sales Engineer of Spang, Chalfant, Inc.

**FRANCIS C. FRARY**  
Director, Aluminum Research Laboratories, Aluminum Company of America.

**F. V. LARKIN**  
Director, Industrial Engineering and Mechanical Engineering, Lehigh University.

**O. A. LEUTWILER**  
Professor of Mechanical Engineering Design and Head of Department of Mechanical Engineering, University of Illinois.

**F. C. SPENCER**  
Manufacturing Engineer, Western Electric Company.

PLASTICS  
FOR  
INDUSTRIAL USE

*An Engineering Handbook  
of Materials and Methods*

JOHN SASSO

*Associate Editor of Product Engineering;  
Member, Society of the Plastics Industry*

FIRST EDITION  
SEVENTH IMPRESSION

McGRAW-HILL BOOK COMPANY, INC.

NEW YORK AND LONDON

1942

PLASTICS FOR INDUSTRIAL USE

COPYRIGHT, 1942, BY THE  
MCGRAW-HILL BOOK COMPANY, INC.

---

PRINTED IN THE UNITED STATES OF AMERICA

*All rights reserved. This book, or  
parts thereof, may not be reproduced  
in any form without permission of  
the publishers.*

## PREFACE

A new and important trend is evident in the use of plastics. More and more engineers are investigating and considering them as engineering materials—not as alternates but as replacements possessing certain inherent characteristics and advantages that can be capitalized on in new engineering designs.

The effect of war and priorities has been to intensify this trend. Materials are no longer available for “gadgets”—they must be used in armament or in essential civilian products. Today plastics are playing a tremendously important part in war equipment and in necessary products.

An engineering approach to plastics involves consideration of material properties and methods of fabrication. Factors affecting choice must next be considered; then design methods and procedures that will result in a satisfactory product. In this text chapters on comparative properties, molding methods, engineering and finishing are followed by chapters on specific materials in which properties and applications are stressed. Chemistry, except as it affects strength or performance, has not been included because mechanical engineers do not need complex molecular diagrams or chemical information on plastics. Discussion has been confined to a limited number of materials which have been found particularly suitable for industrial products.

The engineering information is as accurate as possible considering the peculiar behavior of plastics under varying test conditions. All the data has been secured from manufacturers' research and literature files. The parts of the text that have previously appeared as articles in *Product Engineering*, *Aviation*, *Electronics* and *American Machinist* have been revised and brought up to date. The design engineer should use the book as a comparative guide and idea source for new applications. Before specification, tests must be made and the molder and manufacturer consulted.

For specific suggestions, encouragement and guidance, the author acknowledges with sincere thanks the help of George Nordenholt, editor of *Product Engineering*; William T. Cruse, executive vice-president of the Society of the Plastics Industry, their technical committee and many others in that fine organization; Clinton Blount and Don Masson of the Bakelite Corporation; Herbert Spencer of Durez Plastics and Chemicals, Inc.; M. H. Bigelow of Plaskon Co.; Edmund Greene and D. S. Fredericks of Rohm and Haas; Dennis Guthrie of Tennessee-Eastman Corporation; J. R. Turnbull of Monsanto Chemical Co.; Edward J. Pechin of the E. I. duPont de Nemours & Co., Plastics Division; W. C. Goggin of Dow Chemical Co.; and W. D. Hayton of the General Electric Co.

Companies who furnished engineering data and help in checking the manuscript include: American Cyanamid Co., *American Machinist*, *Aviation*, Bakelite Corp., Carbide and Carbon Chemical Corp., Catalin Corp., Celanese Celluloid Corp., Continental Diamond Fibre Co., Dow Chemical Co., E. I. duPont de Nemours Co., Durez Plastics & Chemicals Co., Inc., Durite Plastics, Formica Insulation Co., General Electric Co., Monsanto Chemical Co., Plaskon Co., Rohm & Haas, Synthane Corp., Tennessee-Eastman Corp., Westinghouse Electric & Mfg. Co.

Without the whole-hearted cooperation of these companies, the preparation of this text would have been impossible.

JOHN SASSO.

NEW YORK,  
September, 1942

# CONTENTS

	PAGE
PREFACE. . . . .	v
CHAPTER	
I. TYPES AVAILABLE, BASIC COMPOUNDING MATERIALS. . . . .	1
II. COMPARATIVE PROPERTIES OF PLASTIC MATERIALS . . . . .	11
III. BASIC PRINCIPLES OF MOLDING AND MOLD DESIGN . . . . .	27
IV. PRINCIPLES OF DESIGN. . . . .	40
V. COMMON FAULTS, CAUSES AND REMEDIES IN MOLDED PARTS . . . . .	56
VI. MACHINING AND FINISHING PLASTIC PARTS . . . . .	71
VII. PHENOLIC PLASTICS . . . . .	86
VIII. CAST PHENOLICS. . . . .	98
IX. UREA PLASTICS . . . . .	104
X. ACRYLIC PLASTICS . . . . .	109
XI. POLYSTYRENE MATERIALS. . . . .	144
XII. VINYL PLASTICS . . . . .	155
XIII. VINYLIDENE CHLORIDE . . . . .	162
XIV. CELLULOSE ACETATE PLASTIC. . . . .	171
XV. ETHYL CELLULOSE. . . . .	181
XVI. LAMINATED PLASTICS. . . . .	185
XVII. PLYWOODS AND ADHESIVES . . . . .	201
APPENDIX	
DIRECTORY OF TRADE NAMES, SUPPLIERS, AND MOLDERS . . . . .	215
INDEX. . . . .	225



# PLASTICS FOR INDUSTRIAL USE

## CHAPTER I

### TYPES AVAILABLE, BASIC COMPOUNDING MATERIALS

In preparing to design a product consisting wholly or in part of plastic material, the engineer must investigate (1) the physical, thermal, electrical, and chemical properties of the plastic, to determine whether it will withstand the specified operating conditions to which it will be subjected, and its expected service life; (2) the design limitations of the plastic material, which relate somewhat to its physical properties but which, to a great extent, will depend on the method of production of the finished part; (3) economy of production, which takes into consideration the cost of molds and tools, the time involved in tooling, and the expected quantity of parts to be obtained from the initial tooling; (4) the cost of the plastic product in relation to the market of similar products made of other materials, considering what advantages the plastic product may have in structural qualities, lightness of weight, and appearance. In many instances, it may be possible to sacrifice one or two strength considerations for appearance.

The wide range of plastic materials, many of which are available with special physical properties to meet certain application requirements, makes the choice of a proper material difficult for a designer not too well versed in the plastics field. Much information has been published on the various materials, their properties, and characteristics, but the mass of it is so great and the field of application so broad that it is hard for the engineer to get a clear definitive picture that will enable him to evaluate plastic materials in relation to the particular design problem at hand.

One method of classifying those plastics of interest to the engineer is to divide the available materials into thermosetting

and thermoplastic groups. Progress in the chemistry of plastics and in the development of new fillers has been so rapid, however, that there are types that can fall into either group. Hard and fast distinction cannot always be made.

For the purposes of definition, it may be said that a thermosetting material is one that under the application of heat and pressure polymerizes into a hard infusible product which will

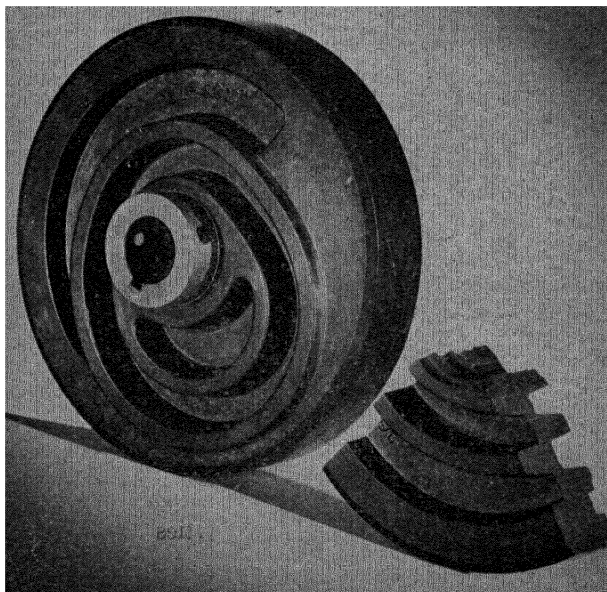

FIG. 1.—Cam of molded laminated phenolic material. (Courtesy of General Electric Company.)

not soften to any extent on reheating and cannot be remelted and remolded. A thermoplastic material can be softened by heat and rehardened into solid state by cooling. The most obvious distinction between thermosetting and thermoplastic materials is that the latter may be remelted and remolded any number of times.

Because a material is thermosetting, it does not necessarily follow that it is particularly resistant to heat. Nor does it necessarily follow that, because a thermoplastic can be softened by heat, it has no heat resistance. Working temperatures for

both may approach 200 deg. F. At higher temperatures the thermosetting material may char, then decompose; the thermo-

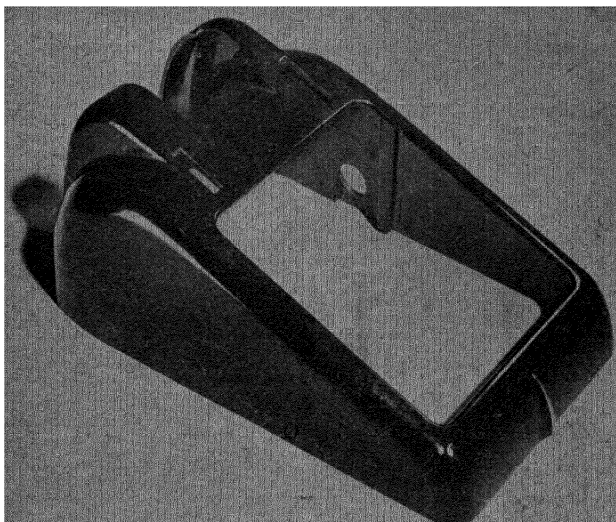

Fig. 2.- Inherent finish, light weight, strength, and acoustical advantages were obtained through the use of molded phenolic material for the Victor adding-machine housing.

plastic material will soften until fluid and then perhaps decompose if the temperature rises high enough.

#### SYNTHETIC RESINS

Thermoplastic	Thermosetting
Polystyrene	Phenol or cresol aldehydes
Polymethyl methacrylate	Urea aldehydes
Polyvinyl chloride-acetate	Melamine-formaldehyde
Polyvinyl chlorides	Aniline formaldehyde
Polyvinyl acetate	Glyceryl phthalates
Polyvinyl acetals	
Vinylidene chloride	

#### CELLULOSE DERIVATIVES

Cellulose nitrate	Cellulose acetate-butyrate
Cellulose acetate	Ethyl cellulose

Most plastics are derived from synthetic resins, cellulose derivatives, natural resins, and protein substances. So many types are available commercially that it is difficult to classify

them simply. For the purposes of a brief consideration of those plastics on the market at present, classification is made with respect to their origin and to whether they are thermosetting or thermoplastic. The table on page 3 covers only those plastic materials derived from synthetic resins and cellulose compounds. Groups not considered are the proteins (casein) and the natural resins (shellac, rosin, asphalt, pitch).

### BASIC COMPOUNDING MATERIALS

Binders, fillers, plasticizers, dyes, lubricants, and solvents are among the various basic substances that are used in the production of plastic molding materials. Such a listing of components is chemically inaccurate, since it is by no means complete, and different substances can serve various purposes in the formulation. However, only those basic substances which affect final properties will be briefly discussed. This will fix in the design engineer's mind the reasons for their use in the formulation and give him some idea of how these substances affect the engineering properties of the plastic material.

### BINDERS

Synthetic resins, cellulose compounds, and protein compounds are usually considered as binders.

The basic materials for synthetic resins may be said to be coal, air, cellulose, limestone, petroleum, salt, and water. From these basic raws are obtained urea, nitric acid, phenol, acetylene, phthalic anhydride, ethylene, methanol, formaldehyde, cellulose acetate, cellulose nitrate, ethyl cellulose, and many others.

The synthetic resins can be used with or without fillers, but are usually compounded with fillers. The resins are available in liquid form for impregnating paper or fabric or, for use in varnishes, adhesives, and surface coatings, and as a bond in grinding wheels and the like.

Phenol resins may be obtained as a by-product of the distillation of coal. Phenol is separated from the anthracene oils by treatment with caustic soda. Formaldehyde is obtained from the oxidation of methanol or from wood alcohol.

Cellulose binders are obtainable from two sources: cotton linters or wood pulp. These binders are treated with nitric acid and then mechanically and chemically washed. The raw materials

are synthesized into cellulose acetate resin. The cellulose resins are mixed with a plasticizer which is added in some cases to increase flow properties for ease of molding, added in others to increase impact strength. These plasticizers include sulfonamides, phthalyl glycolates, triphenyl phosphates. They have a marked effect on physical properties. Generally, tensile and compressive properties decrease on increasing plasticizer content. As a result, the grades of plastic compounded for ease of flow will show minimum strength properties and vice versa.

### FILLERS

Added to resins, fillers make a wide range of properties possible. Various fillers may be compounded with the resin to obtain special high electrical, chemical, and impact resistance or to improve moldability. Fillers are especially important in the phenolic materials and make possible the hundreds of formulations offered by materials manufacturers.

Typical fillers for phenolics include wood flour, cotton, fabric, graphite, asbestos, mica. Urea resins are generally compounded with purified wood cellulose (alpha-cellulose). The effect of fillers on properties may be easily seen by reference to the chart on molded thermosetting plastics (page 14) which also gives an idea of the applications and limitations of various types of filled materials.

### EFFECTS OF FILLERS

Wood flour is the most common filler used in phenolic materials. This filler has a low specific gravity, therefore the number of moldings per pound is higher. Other advantages obtained by its use are good moldability, good appearance of the molded surface, low heat conductivity. However, wood-filled phenolics have only fair impact strength and are subject to shrinkage in service. Applications of the general-purpose wood-filled phenolics are limited only by strength, heat resistance, and colors available.

Cotton fillers improve impact strength and increase impact resistance. Though for higher impact strength rag filler is generally required, cotton flock is widely used for parts requiring medium impact strength. Parts made of cotton-filled phenolic can be easily buffed and polished and can be tableted easily—an

important factor in maintaining high hourly production rates in compression molding operations.

Rag fillers increase impact strength, this increase depending on the length and type of fiber. Increase in strength is obtained at the expense of some other properties, notably poor surface finish and poor machinability. Rag-filled phenolic has a relatively poor flow.

When heat resistance is paramount in the molded part, asbestos fillers are compounded with the phenolic resin. Asbestos fillers

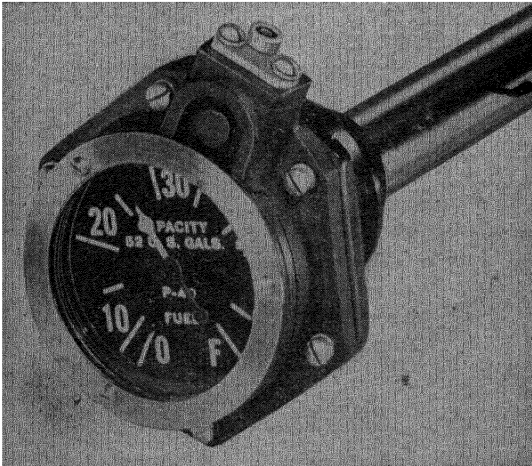

FIG. 3.—Double windows of methyl methacrylate are used in this aircraft gasoline gauge. Upper window can be replaced when scratched.

also impart a good degree of water resistance, as well as resistance to most acids. These fillers retard somewhat the molding operation because of reduced flow. Another disadvantage is the high specific gravity, which of course proportionately reduces the output of parts per pound of molding material.

Mica is used to impart good electrical resistance; it is the filler for low-loss compounds with excellent insulating qualities. Poor machinability is a characteristic. Because of brittleness, parts molded of mica-filled compounds cannot be drilled.

Graphite fillers, generally used in combination with wood flour, asbestos, and rag, impart acid resistance and improve molding qualities because the graphite serves as lubricant. How-

ever, poor heat conductivity is noted. This filler is used in phenolics for moldings of bearings, castor wheels, slides, and the like.

Other fillers, of course, are available. For instance, to increase the yield per pound of molded parts, a low specific gravity substance, silica in diatomaceous form, can be used. This substance as a filler will give fair electrical properties, fairly low water absorption. Barium sulphate fillers add chemical resistance. Talc imparts lubricating qualities.

To summarize, fillers are added to resins in order to obtain qualities that the resin itself does not have (hardness, strength, chemical resistance), or they may be added to speed fabrication (lubricants). Experimentation is continuing among manufacturers and interesting results are being obtained with certain organic fillers, such as soybean protein for flow properties and ramie fiber for increased strength.

## **RÉSUMÉ OF THE MORE IMPORTANT TYPES OF PLASTICS\***

### **PHENOL FORMALDEHYDE**

Phenolic resins are thermosetting in nature and in their final or cured forms are infusible and insoluble. They can be compounded with fillers and reinforcing agents so as to obtain a broad range of physical, electrical, chemical, and molding properties. Phenolic material is very widely used in industry. Cast phenolics have recently been found useful in industrial applications such as pump gears. In consumer products, they have long been used because of gemlike luster, wide color selection, and easy machinability. On the other hand, molded phenolics have only fair machinability and are definitely limited in their range of color.

Molding materials are available in powdered, granular, or sheet form. Laminated and cast materials are available as sheets, rods, bars, and tubes.

Molded phenolics are used for cams, bearings, switch boxes, motor housings, and radio housings. Laminated phenolics are fabricated into gears, bearings, and parts requiring electrical insulating characteristics.

\* A complete list of trade names and manufacturers will be found on p. 215. Separate chapters on each type of plastic begin on p. 86.

## UREA FORMALDEHYDE

The urea plastic materials possess the unusual combination of thermosetting qualities with a wide assortment of colors, including many of the delicate pastel shades. Ureas have good dielectric properties, good tensile and flexural strength. Urea molding materials are available in powder or granular form and laminated materials are available in sheet form.

Urea moldings have been successful for such applications as scale housings, thermostat housings, lighting fixtures, clock casings, and radio cabinets. Their fine and wide assortment of colors, including white and pastel shades, combined with moldability and insulating properties, has led to wide use.

## ACRYLIC RESINS

The acrylic resins possess some of the most desirable optical properties of the transparent plastic materials. Because of crystal clarity, stability, resistance to weathering, and moldability, acrylics have attained wide popularity as an organic glass. Since acrylics are thermoplastic in nature, they can be easily fabricated into complicated shapes or forms wherein transparency and light piping are useful characteristics. Acrylic resins are available as molding powders or as cast sheets, rods, bars, and tubes. Typical applications include aircraft cockpit enclosures and blisters, instrument dials and bezels, transparent housings, and molded reflectors.

## POLYSTYRENE

This thermoplastic material is noted for its excellent dielectric properties and optical clarity. The material exhibits increase of strength as temperature decreases and has excellent chemical resistance. Molding materials are available in granular form for compression, as well as injection, molding.

Polystyrene has been used as an insulating foil for radio condensers and coil insulation. It has been designed into coil supports for high-frequency apparatus and instrument housings, supports for the conductor in coaxial cables, and as acidproof closures, refrigerator parts, and instrument lenses.

### VINYL COPOLYMER

Of the same family group which includes the polystyrenes, the copolymers of vinyl chloride and vinyl acetate have unusual chemical inertness and produce transparent, translucent, and opaque moldings. They have good elasticity at low temperature



FIG. 4.—Wet-battery housing molded of polystyrene. Light weight, acid resistance, and good electrical characteristics were factors in the choice of material.

and possess toughness and excellent dimensional stability. Applications include goggles, steering wheels, and molded gaskets.

### CELLULOSE ACETATE

Developed to overcome the disadvantages of flammability and color instability of cellulose nitrate, cellulose acetates first came into prominence as safety film for motion pictures. Characteristically, they possess toughness and resiliency and are available in a tremendously wide range of colors. Forms available are

sheets, rods, tubes, bars, molding blanks, molding powders of every description, films, packaging materials, and foils.

Among the applications are numerous industrial and household molded articles, such as radio cabinets, tool handles, automotive hardware, goggles, instrument lenses, and many other injection-molded pieces.

Other cellulose derivatives of importance are cellulose acetate-butyrate, a molding material of high impact strength, and ethyl cellulose, a plastic similar to acetate having inertness to alkalis and dilute acids, and flexibility at low temperatures.

#### VINYLDENE CHLORIDE

This new plastic is noted for high tensile strength and excellent aging properties. It is resistant to heat and to most chemicals. Applications are primarily industrial; these include molded industrial spray-gun handles and, in the extruded form, gasoline tubing, coolant lines, and water lines for humidifying apparatus. This plastic has only recently been available in any quantities. It is marketed as Saran.

The foregoing brief descriptions have been given to set the stage, as it were, for the consideration of plastics as engineering materials. In the following chapter comparative properties in groups will be discussed. Further on in the text, one chapter is devoted to each particular plastic. Physical, chemical, and thermal properties are given in detail, as well as information on applications and limitations in use.

## CHAPTER II

### COMPARATIVE PROPERTIES OF PLASTIC MATERIALS

The following general tabulations and comments on properties and characteristics are offered only as a means for quick, comparative study. More detailed information and data on physicals and characteristics are to be found in the chapters devoted to the specific plastic materials. A word of caution on acceptance of comparative values is necessary. Plastics are synthetics, hence atmospheric conditions, operating conditions, formulation, molding, and curing will, to a greater or lesser extent, influence their behavior in service.

The engineer should make it a fundamental rule, after first studying a plastic material for possible inclusion in his design, to get full information on that material from the manufacturer, with particular reference to what test conditions were used to determine the physical, chemical, thermal, and electrical values. In this connection, the A.S.T.M. has published specifications and testing standards for plastics that have been accepted throughout the industry (see Table 7). Consultation with an experienced molder before final design prints are made will repay the engineer in many ways. The molder knows how various materials will behave under fabrication and whether it is economically feasible to use the desired fabrication process. Further, he may be in a position to suggest slight changes in design that will speed production and may reduce cost.

#### WEIGHT

On a weight basis, plastics offer the designer considerable advantage over metal, but they should never be selected on the weight basis alone. The weight-saving possibilities of molded plastics make them particularly suitable for portable equipment, household machinery, and transportation equipment. An outstanding example of weight reduction with plastics is that of the Toledo Guardian Duplex scale. First designed with an enameled

steel housing, the scale weighed 157 lb. With a molded urea housing, the weight was 56 lb. As a result of careful design and study of materials, manufacturing costs were reduced, appearance

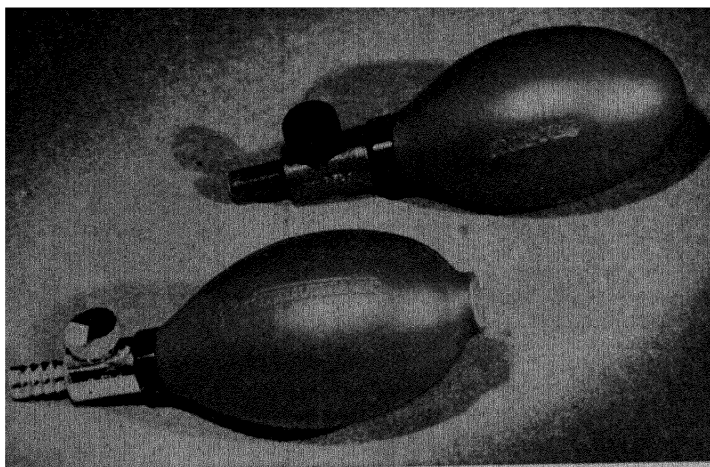
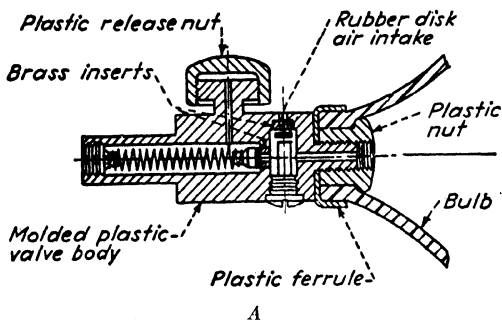

B

FIG. 5.—Air-intake valve, outlet valve, and release valve are one molded plastic unit in the new Baumanometer bloodpressure apparatus. Cellulose acetate-butyrate is the material, chosen for light weight, dimensional stability, and moisture resistance.

improved, and freight charges sharply lowered. Nonchipping, ease of cleaning, and permanence of color were additional features obtained through the design change.

Advantage can be taken of the high strength-weight ratios of plastics in the design of component parts for aircraft and transportation equipment. In aircraft, plastics are successfully

used in nonstructural applications, such as flooring, conduit, and pulleys. Acrylic sheets, used for cockpit and blister enclosures, are standard not only because they have less than half the weight of glass but because they can be easily formed to complex shapes. Besides these advantages, the designer will perhaps be able to capitalize on the nonshattering characteristics inherent in the acrylic plastics. A disadvantage in some applications is that acrylic sheet is susceptible to scratching and marring. In machinery designs, where moving parts reverse direction, inertia forces are set up; plastic parts often help solve the problem of attendant vibration.

Resin-bonded plywoods, discussed in Chap. XVII, have been used to fabricate aircraft fuselages and wings on an experimental

TABLE 1.—SPECIFIC GRAVITIES OF MATERIALS

Material	Specific gravity	Material	Specific gravity
Aluminum . . . . .	2.67	Mica . . . . .	2.85
Amber . . . . .	1.1	Oak . . . . .	0.86
Asbestos . . . . .	3.0	Phenolic:	
Brass (70-30) . . . . .	8.4	Cast . . . . .	1.27-1.32
Bronze . . . . .	8.8	Wood flour . . . . .	1.25-1.52
Casein . . . . .	1.33	Laminated . . . . .	1.34-1.55
Cellulose acetate . . . . .	1.27-1.63	Mineral . . . . .	1.50-2.09
Cellulose acetobutyrate . . . . .	1.20-1.22	Fabric . . . . .	1.37-1.40
Cellulose nitrate . . . . .	1.35-1.60	Polystyrene . . . . .	1.06
Copper . . . . .	8.9	Porcelain . . . . .	2.3
Ebony . . . . .	1.23	Rubber, hard . . . . .	1.12-1.80
Ethyl cellulose . . . . .	1.14	Silver . . . . .	10.5
Glass, plate . . . . .	2.6	Steel:	
Iron, cast . . . . .	7.22	stainless . . . . .	7.78
Lead . . . . .	11.38	cast . . . . .	7.81
Magnesium (commercial) . . . . .	1.76-1.83	Urea . . . . .	1.45-1.50
Maple . . . . .	0.68	Vinyl resins . . . . .	1.25-1.41
Methyl methacrylate . . . . .	1.18		

basis. Some Army trainers today have structural parts of resin-bonded plywood. Recently, it was announced that plywood gliders were to be produced in quantity for the Army.

TENSILE STRENGTH

This is one of the properties of a plastic material that is subject to considerable variation depending on manufacture, molding

technique, degree of polymerization, amount and kind of fillers and plasticizers present, temperature, and moisture. Consequently the accompanying tabular matter and comments apply on a qualitative basis only.

TABLE 2.—AVERAGE PHYSICAL PROPERTIES OF PLASTICS

Material	Tensile strength, lb. per sq. in.	Compressive strength, lb. per sq. in.	Flexural strength, lb. per sq. in.	Impact strength Izod, ft.-lb. per in. of notch, $\frac{1}{2}$ -by $\frac{1}{2}$ -in. bar
<b>Phenolic:</b>				
Wood-flour filled	4,000-11,000	16,000-36,000	8,000-15,000	0.15-0.25
Mineral-filled....	4,000-10,000	18,000-36,000	8,000-20,000	0.13-0.72
Macerated fabric-filled.....	5,000- 8,000	20,000-32,000	8,000-13,000	0.8 -4.8
Cast phenolic.....	3,500- 9,000	10,000-30,000	9,000-14,000	0.15-0.4
<b>Laminated phenolic:</b>				
Paper base.....	7,000-18,000	20,000-40,000	13,000-20,000	0.6 -7.6
Cotton base.....	8,000-12,000	30,000-44,000	13,000-30,000	1.4 -15
Asbestos base...	7,000-12,000	18,000-45,000	10,000-35,000	1.8 -11
<b>Phenol furfural</b>				
Wood-flour filled	6,000-11,000	28,000-36,000	8,000-15,000	0.30-0.56
Mineral-filled....	5,000-10,000	24,000-36,000	8,000-20,000	0.32-0.74
Fabric-filled.....	6,500- 8,000	26,000-30,000	10,000-13,000	1.20-4.60
Urea.....	5,000-13,000	24,000-35,000	10,000-15,000	0.28-0.32
Vinyl chloride.....	8,000-10,000	10,000-12,000	12,000-14,000	0.6 -1.2
Vinylidene chloride	4,000- 7,000	7,500- 8,500	15,000-17,000	
Methyl methacrylate.....	4,000- 7,000	10,000-15,000	10,000-15,000	0.2 -0.4
Polystyrene.....	5,000- 9,000	11,500-13,500	14,000-19,000	0.35-0.50
Ethyl cellulose.....	6,000- 9,000	10,000-12,000	4,000-12,000	0.6 -6.5
Cellulose acetate-butyrate.....	2,500- 7,500	7,500-22,000	2,800-13,000	0.8 -5.5
Cellulose acetate...	3,000-10,000	7,000-26,000	3,700-18,000	0.7 -4.2

Without going too deeply into the chemistry, it may be said generally that plastic materials develop tensile properties during formation of the molecular structure of the resin. Where polymerization takes place during molding, as in the phenolic and

urea resins, tensile strengths will depend to some extent on molding technique. Undercuring will reduce tensile strength. Flow lines caused by nonuniform flow in the mold may be the starting points for mechanical failure. Internal strains in the molded part reduce physical properties.

In thermoplastic molding, weld lines may appear. These marks occur where the mold design is such that the plastic stream is forced to separate and then reunite in the mold. Unless care

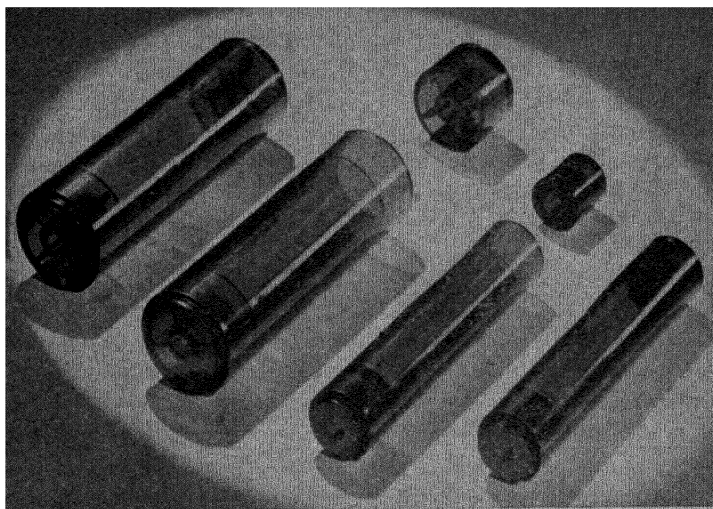

FIG. 6.—Machine-gun ammunition rollers of cellulose acetate-butyrate. Each roller consists of molded tube with pressed-in molded bearings which fit against molded-in shoulders in the tubes.

is taken in design of the mold and in selecting material with proper flow characteristics, this region in the finished part may be considerably lower in strength than the rest of the piece.

As brought out in the chapter on basic materials used in compounding plastics, fillers and plasticizers are important factors in determining the strength and serviceability of the finished molded piece. Fillers have, of course, great effect on impact strength, flexural strength, and flow. Plasticizers that are added to thermoplastics to obtain desired flow properties will affect the strength of the molded part. When certain molding qualities are obtained, tensile properties will usually be reduced.

The acetates with the best flow show the lowest strength and vice versa.

Temperature has a marked effect on physical properties. With plastics, even small changes in temperature will cause variation from the tabulated properties of the materials, particularly the thermoplastics. For instance, tests have shown that one type of polystyrene, which has a tensile strength of 5,000 lb. per sq. in. at 175 deg. F., has a tensile strength of 8,000 lb. per sq. in. at -4 deg. F. On the other hand, some plastics lose strength rapidly as temperature increases. Thus temperature-sensitivity characteristics of plastics are extremely important and will bear considerable study by the design engineer. Conditions under which the plastic part must operate should be very carefully anticipated. Ambient temperature in particular should be taken into account. Humidity also affects strength. As a general rule, it will be found that as plastics absorb moisture, they will show a small reduction in tensile strength.

### COMPRESSIVE STRENGTH

Laminated phenolics, particularly those which are reinforced with canvas, have high compressive strength—a characteristic that has led to their adoption as cams, gears, and bearings and to certain other machinery applications. In molded parts, the best compressive strength is shown by wood-flour filled phenolics and furfurals. Thermoplastics have distinctly lower compressive strengths. Temperature affects compressive strength much as it does other physical properties. For parts that must take heavy loads, many designers mold thermoplastics over metal inserts, which take a considerable part of the load.

### IMPACT STRENGTH

Fillers and plasticizers play an important part in determining the impact strength of plastic parts. In phenolics, fibrous fillers increase impact strength; in thermoplastics, greater proportions of plasticizer improve impact characteristics. For example, a molded phenolic with long fabric filler has approximately ten times the impact strength of wood-flour filled, three times the impact strength of cotton-filled, and twice the impact strength of shredded-fabric filled phenolic. Certain formulations of

ethyl cellulose, cellulose acetate, and cellulose acetate-butyrate show high impact strengths.

A word of caution should be introduced here, to point out that again operating conditions, particularly of temperature, must be especially considered when impact strength is a vital factor in part design. Some thermoplastics become brittle at low temperatures and lose impact strength. At high temperatures, volatilization of the plasticizer may make the molded part brittle, reducing impact strength. If the temperature is further increased, softening may occur. Phenolic parts show considerable reduction in impact strength at temperatures of 200 deg. F. and above.

Impact characteristics of a molded part are greatly dependent on proper design, as pointed out in Chap. IV. Obviously, if a part is subjected to repetitive impact, failure will occur at lower stresses than under static loading. It is generally good practice when designing to allow a factor of safety of at least 3 for impact calculations based on strength tables for the various materials.

Data on elongation, elastic limit, elastic modulus, hardness, and other physical characteristics will be found in the detailed chapters on the various plastic materials. It might be added here that these properties also depend to a great extent on the filler, plasticizer, and temperature to which the material is subjected in service.

### THERMAL PROPERTIES

As previously stated, the broad classifications of thermosetting and thermoplastic do not serve as indications of the thermal properties of plastics. Generally speaking, plastics have relatively low thermal conductivity. This characteristic is valuable for certain applications, such as flatiron handles, electrical equipment, knobs and plugs, automotive steering wheels. It is this property which accounts for the pleasant touch so much referred to in describing the advantages of plastics. Low thermal conductivity is often taken advantage of in industrial applications where the plastic used also furnishes good structural and electrical qualities.

It is important in design to determine the maximum temperature to which the part will be subjected. This, of course, has been stressed previously. Proper measures taken during design

may avoid failures due to temperature. Temperature may cause changes in physical dimensions because of softening; it may also increase creep and cold flow and cause dehydration or volatilization of the plasticizer in thermoplastic compounds. The heat distortion point, as determined by standard test, serves as a criterion.

TABLE 3.—THERMAL PROPERTIES OF PLASTICS

	Thermal conductivity, 10 <sup>-4</sup> cal./ (sec.) (sq. cm.) (deg. C.) (cm.)	Distortion point, deg. F.
Phenolic:		
Wood-flour filled.....	4-12	240
Mineral-filled.....	8-20	290
Cast phenolic.....	3-5	
Laminated phenolic:		
Paper base.....	5-8	
Cotton base.....	5-8	
Asbestos base.....	7-9	
Phenol furfural:		
Wood-flour filled.....	3-5	
Mineral-filled.....	10-20	
Fabric-filled.....	5-8	
Urea.....	7	260
Vinyl chloride.....	4	140
Vinylidene chloride.....	2.2	240
Methyl methacrylate.....	4-8	160
Polystyrene.....	3-5	170
Ethyl cellulose.....	5-6	140
Cellulose acetate.....	5-8	150
Cellulose acetate-butyrate.....	5-8	150

As a matter of caution, it is well to consider that the greater the stress in a part, the lower the safe temperature of operation. Along with the heat distortion point, the engineer should investigate the effect of that temperature on other properties of the plastic. Some may embrittle at temperatures over 170 deg. F. Other plastic materials may lose color or suffer reduction in dielectric strength.

Thermal expansion is an important design factor for products combining plastics and metals, particularly where mating parts are concerned. Shrinkage and expansion for a given temperature differential are considerably greater in plastics than in metals.



Thermal expansion must be considered in relation to chemical changes that occur with aging and heat, such as dehydration, volatilization of plasticizer, and even further polymerization. These will all cause slight shrinkage when they occur. The effect of these variables can be minimized by proper design, as brought out in Chap. IV.

By study of the data presented, it will be found that temperature has a decided effect on other properties of plastics—reducing electrical properties, lowering chemical resistance, and exerting, as mentioned previously, considerable influence on physicals.

### ELECTRICAL PROPERTIES

Plastics are used in many electrical applications: radio, signal, and transmission parts, aircraft and switch mountings, telephone equipment, industrial controls and housings. In many cases they serve structural, insulating, and appearance purposes, and in addition offer the designer advantages of quick assembly and good sales appeal.

Electrical properties in service life of plastic molded parts depend to a great extent upon proper design, operating temperatures, and conditions of humidity. Many times it will be possible by proper design to obtain better electrical performance of the part, as discussed in Chap. IV: Generally speaking, high operating temperatures adversely affect electrical properties. For example, dielectric constants of the phenols change considerably with rise in temperature. At high operating temperatures, dielectric strength is adversely affected, as is insulation resistance. The amount of moisture absorbed by the material also affects electrical properties. Dielectric constants and power factor of phenolic molded increase in proportion to the amount of water absorbed. The water absorption of some of the plastic materials reduces surface resistivity. Obviously, it is to the interest of the designer to make a thorough investigation of service conditions and to test thoroughly the plastic materials before final specification.

When studying plastics for inclusion in designs where electrical properties are important, data on six characteristic factors should be obtained by standard test before specifying. Manufacturers maintain engineering services for study and recommendation of plastic materials in applications where electrical properties are

of paramount importance. The designer should avail himself of these consulting facilities. The six factors on electrical properties are dielectric constant, dielectric strength, power factor, loss factor, insulation resistance, and arc resistance. This listing is not necessarily in the order of design importance, as the require-



Fig. 7b.—Focal-Lite hand lantern, of cellulose acetate-butyrate.

ments of the particular application will determine the factors for further investigation. And, of course, temperature and moisture conditions must be brought into the analysis before final choice and design are made.

The dielectric constant, or ratio of the capacity of a condenser with a given dielectric to its capacity with air as the dielectric, is usually measured at 60 cycles, 1,000 cycles, and 1,000,000 cycles. These constants are of particular importance in radio

circuits. They are shown in Table 4 for comparative analysis; the values given are based on manufacturers' literature.

Dielectric strength, or the maximum voltage that a material will withstand before puncture divided by the thickness of the material, is expressed in volts per mil. Two factors affect this measure: the rate of voltage increase and the thickness of the material under test. Three methods of testing are approved and have been standardized by the A.S.T.M. These are the short-time test, the step-by-step method, and the endurance test. Of these, the easiest to apply and the most commonly used is the

TABLE 4.—DIELECTRIC CONSTANTS

	60 cycles	1,000 cycles	1,000,000 cycles
Phenol formaldehyde:			
Wood-flour filled . . . . .	5-12	4-8	4.5-8
Fabric-filled . . . . .	5-10	4.5-6	4.5-6
Mineral-filled . . . . .	5-20	4.5-20	4.5-20
Cast phenolic . . . . .	5-10	.....	5-7
Laminated phenolic:			
Paper base . . . . .	.....	.....	3.6-5
Fabric base . . . . .	.....	.....	3.6-5
Urea formaldehyde	6.6-8.6	.....	5.5-7.7
Polystyrene . . . . .	2.6 <sup>†</sup>	2.5	2.5
Cellulose acetate . . . . .	3.5-6.4	3.5-6.4	3.2-6.2
Methyl methacrylate . . . . .	3-3.7	3-3.5	2.8-3.3
Ethyl cellulose . . . . .	2.7	2.5-3.5	2-3
Vinyl copolymer . . . . .	3.2-3.6	3.2-3.4	3.0-3.4
Vinylidene chloride . . . . .	3-5	3-5	3-5
Hard rubber . . . . .	2-8	2.8-3.4	3
Quartz . . . . .	.....	4.1	4.1
Air . . . . .	1	1	1

short-time test, where voltage is applied at the rate of 0.5 kv. per sec. until puncture occurs. Material thickness is measured at the point of failure. Dielectric strength is a function of temperature; the higher the temperature the lower the dielectric strength. As frequencies increase, dielectric strength decreases. With laminated plastics, tests made parallel to the laminations will give lower dielectric strengths.

Other factors that influence dielectric strength are fillers (mica-filled phenolics are high, graphite-filled low), manufac-

turing variables, exposure of material to high humidity. Table 5 shows the approximate dielectric strengths as reported by manufacturers and available in materials customarily considered for electrical applications.

Power factor, or the ratio of power loss in watts to the volt-amperes through a capacitor in which that material is the dielectric, is important in the design of radio-frequency insulators. Moisture-absorbing characteristics of the materials are important, as the power factor may change with absorption of water. For this reason, polystyrene has attained wide acceptance in the electrical field; its moisture absorption is practically 0 per cent in 24 hr.

Phenolic materials of the low-loss type have mica fillers. In manufacture, they are carefully dehydrated. As dielectric materials, however, they cannot compare with polystyrene in many applications. Polystyrene has a power factor of 0.0001 at 60 cycles. Ethyl cellulose shows up well in the power-factor test. The value of its power factor is reported to be 0.0007, which should open up interesting possibilities for the use of ethyl cellulose in electronic applications.

TABLE 5.—DIELECTRIC STRENGTH OF PLASTICS  
 Material Short Time, Volts per Mil,  $\frac{1}{8}$  In. Thickness, 1,000,000 Cycles

Phenol formaldehyde:	
Wood-flour filled	300-500
Mineral-filled	250-400
Macerated fabric-filled	150-450
Cast phenolic	300-450
Laminated phenolic:	
Paper base	400-1,000
Cotton base	150-600
Asbestos base	100-150
Phenol furfural:	
Wood-flour filled	400-600
Mineral-filled	200-500
Fabric-filled	200-500
Urea formaldehyde	680-720
Vinyl copolymer	400-500
Vinylidene chloride	500
Methyl methacrylate	500
Polystyrene	500-525
Cellulose acetate	350-900

Loss factor, or the product of the power factor and the dielectric constant, is of help in comparing materials, since it gives an idea of the heat generation rate per unit volume at certain test conditions. It must, however, be considered in relation to other electrical properties.

TABLE 6.—POWER FACTOR

	60 cycles	1,000 cycles	1,000,000 cycles
Phenol formaldehyde:			
Wood-flour filled . . . . .	0.04-0.30	0.04-0.15	0.03-0.1
Fabric-filled . . . . .	0.08-0.30	0.08-0.20	0.04-0.1
Mineral-filled . . . . .	0.10-0.30	0.10-0.2	0.005-0.1
Cast phenolic . . . . .	0.025-0.20	0.005-0.08	0.01-0.05
Laminated phenolic:			
Paper base . . . . .			0.02-0.08
Fabric base . . . . .			0.02-0.08
Urea formaldehyde . . . . .	0.04-0.06		0.027-0.035
Polystyrene . . . . .	0.0002-0.0003	0.0002-0.0003	0.0002-0.0003
Vinyl copolymer . . . . .	0.01-0.04	0.01-0.02	0.01-0.02
Methyl methacrylate . . . . .	0.05-0.07	0.06-0.07	0.015-0.03
Cellulose acetate . . . . .	0.01-0.06	0.01-0.06	0.01-0.05
Ethyl cellulose . . . . .	0.007	0.005-0.025	0.007-0.03
Vinylidene chloride . . . . .	0.03-0.08	0.03-0.15	0.02-0.05

Insulation resistance of plastic materials is fairly high and ranges from  $10^{18}$  ohms per cm. for polystyrene to  $10^{10}$  for phenolic. Surface conditions will affect the insulation resistance, as will moisture and high temperatures. It will be found that moisture and temperature are particularly critical. Here again, the engineer will do well to make careful tests before proceeding too far. The A.S.T.M. has devised tests to be made under certain specified conditions of temperature and humidity. These will serve as a good measure of the ability of the material at the temperature and humidity conditions of the test. As to behavior at elevated temperatures, further testing and the experience of others are the only guides available. Since much work has been done on this subject, the engineer will do well to consult with manufacturers before proceeding too far with his design.

Arc resistance is a measure of the behavior of the material under a power arc, to determine the amount of carbonisation.

This property will have to be determined by separate tests, under procedure devised by the A.S.T.M. It is important to consult the manufacturer if arc resistance is a requisite of the design. Arc resistance is of particular importance in switch design. Often proper engineering can do much to reduce the danger of tracking.

TABLE 7.—A.S.T.M. TESTING STANDARDS FOR PLASTICS

Designation	Title
D48-39	Testing Molded Materials Used for Electrical Insulation
D257-38	Test for Resistivity of Insulating Materials
D149-39T	Testing Sheet, Tape and Molded Insulating Materials for Dielectric Strength
D150-39T	Testing Electrical Insulating Materials for Power Factor and Dielectric Constant
D229-39	Testing Sheet and Plate Materials Used in Electrical Insulation
D256-38	Testing Electrical Insulating Materials for Resistance to Impact
D467-37T	Phenolic Laminated Sheet for Radio Applications
D325-31T	Test for Comparing the Thermal Conductivities of Solid Electrical Insulating Materials
D348-39	Testing Laminated Tubes Used in Electrical Insulation
D349-39	Testing Laminated Round Rods Used in Electrical Insulation
D374-36T	Test for Thickness of Solid Electrical Insulation
D392-38	Testing Molding Powders Used in Manufacturing Molded Electrical Insulators
D495-38T	Arc Resistance
D542-39T	Index of Refraction of Transparent Organic Plastics
D543-39T	Resistance of Plastics to Chemical Reagents
D494-38T	Acetone Extraction of Phenolic Molded or Laminated Products
D551-39T	Shrinkage from Mold Dimensions of Molded Materials Used for Electrical Insulation
D568-40T	Flammability Test for Plastics
D569-40T	Measuring Flow Temperature of Thermoplastic Materials
D570-40T	Water Absorption of Plastics

### MOISTURE RESISTANCE

The amount of moisture absorbed by a material will affect the dielectric qualities, appearance, and sometimes the dimension of the molded part. Polystyrene and vinylidene chloride show the best moisture resistance of all the plastics, the cellulose

acetates behaving poorly in this respect. Some of the laminated phenolics are compounded for low water absorption to obtain better electrical properties.

TABLE 8.—WATER ABSORPTION

Material	Per Cent in 24 Hr.
Phenol formaldehyde:	
Wood-flour filled.....	0.2-0.6
Fabric-filled.....	0.5-2.5
Mineral-filled.....	0.01-0.3
Cast phenolic.....	0.01-0.5
Laminated phenolic:	
Paper base.....	0.3-9.0
Glass-fabric base.....	0.3-0.5
Urea formaldehyde.....	1-3
Polystyrene.....	0.0
Vinyl copolymer.....	0.05-0.15
Methyl methacrylate.....	0.4-0.5
Cellulose acetate.....	1.3-6.9
Ethyl cellulose.....	0.5-1.5
Vinylidene chloride.....	0.0

## CHAPTER III

### BASIC PRINCIPLES OF MOLDING AND MOLD DESIGN

Some knowledge of the fundamentals of the molding processes for plastic materials is required so that the engineer can take into account certain advantages and limitations that the method of molding may or may not impose on his design. For instance, if he selects a fibrous-fabric-filled phenolic for a complicated part requiring high impact strength, he will have to place ample fillets around corners, allow sufficient anchorage for inserts, and make sure that the molten material reaches all parts of the mold in sufficient quantity. In all cases, easy removal of the part from the mold must be allowed for in design.

This chapter purposes to acquaint the engineer with the fundamentals of the molding processes and to give him some background information on the various types of molds and their design. For complete information on the molding processes and molds, recourse must be made to the literature. And, as already pointed out, the engineer should have more than a nodding acquaintance with his own, or his custom, molder and the material supplier. In fact, the closer these men work together, the more successful the design.

#### MOLDING PROCESSES

Molding processes can be placed in two distinct classifications: compression and injection. Extrusion is a form of injection molding. In compression molding, a charge either in granule or tablet form is placed in the mold, the mold closed and heat and pressure applied for a certain time. In injection molding (primarily used for thermoplastic materials) the granular material is placed in a hopper, fed to a heating cylinder, and forced by pressure through a nozzle into the closed die. After it is cooled, the mold opens and the piece is ejected. Injection molding is well suited to automatic cycles but is limited by available equipment to parts with surface area of 200 sq. in. or

less. Extrusion of thermoplastics employs a heating cylinder, pressure, and an extrusion die shaped to the desired section. The material is forced out and coiled up as it cools.

### COMPRESSION MOLDING OF THERMOSETTING MATERIALS

Heat-setting materials (phenolic and ureas) require not only heat for plasticization but also the application of proper heat for a period of time to polymerize or set them. These materials are usually molded by the compression process. The material is loaded directly into the mold cavity. With the application of heat and pressure, the material becomes plastic and then permanently hardens.

Economical commercial molding of hot-set plastics depends upon the following:

1. Ease of loading. The more conveniently a mold can be loaded the more efficient the molding operation will be, for molds are idle while being loaded. Saving in loading time results in lower molding costs.

2. Proper heat properly applied. The heat must be applied simultaneously to the molding material charge and to the part while undergoing hardening. Proper pressure is also important. Greater pressure is required for molding large flat shapes, such as trays, where there is a compressive rather than flowing action. Long flow requires greater pressure. Minimum pressure is required for flash-type molds, especially in fabricating simple shapes. Care should be taken so that the pressure is not ineffectively dissipated because of too great land areas or uneven or short loading of cavities.

3. It must be possible to remove the piece without damaging or distorting it.

### TRANSFER MOLDING OF THERMOSETTING MATERIALS

In this method, the material is plasticized by outside heating in a cylinder separate from the mold proper and then, as a hot plastic, it is transferred through an orifice into the hot mold where it is to be set or hardened. This method may be advantageous when the part design requires delicate insets, when it has an intricate shape, or when large variations in wall thicknesses are unavoidable because of design requirements.

## INJECTION MOLDING OF THERMOPLASTIC MATERIALS

Cold-set materials (thermoplastics) require heat to plasticize them. They require cooling to harden. Two methods are used to mold these plastic materials: injection and compression.

In injection molding, the material is heated to a sufficiently plastic state in a heating chamber and then forced by a pressure plunger through an orifice into a relatively cold mold where the molding is formed. The material takes shape and hardens on cooling.

The principles for economical injection molding differ from those for compression molding:

1. The feed of the cold-set or thermoplastic material must be uniform and of proper quantity. Too small a feed will cause short castings due to insufficient material. Too great a feed will cause flashing of the mold or choking of the machine with resultant short molding.

2. Optimum temperature of the material in the heating cylinder must be constantly maintained. To maintain consistently good production, variations in time cycle and temperature should be minimized. The amount of heat necessary is determined by the plasticity of the molding material as well as the pressure and the over-all cycle; the minimum amount necessary is used. The lower the heating cylinder temperature the smaller the chances of burning and leakage of the plastic from the nozzle of the heating cylinder.

3. Proper pressure on the plastic material in the mold must be maintained. Since the viscosity of the material varies directly as the temperature, the effective pressure will also vary with the temperature of the material. The temperature and the effective pressure must be kept constant.

4. To ensure that the molding can be ejected without distortion or damage, it must be cooled to a point where it is sufficiently rigid to withstand slight deformation. The temperature of the mold, the temperature of the injected molding material, the length of time the material is chilled in the die, and the rate and means of ejection are factors that must be carefully regulated and controlled. With materials having negligible water absorption, it is possible to effect time saving by ejecting the piece, partly cooled, and chilling it by immersing it in cold water.

Such pieces will not have consistent dimensions. Where close tolerances need not be held, this procedure permits fast production.

### COMPRESSION MOLDING OF THERMOPLASTIC MATERIALS

This is performed on the same type of equipment that is used in compression molding of thermosetting materials, except that allowance is made for faster and more uniform heating and cooling of the molds. As these materials soften under heat and harden on cooling, the mold must not only be heated to plasticize the material but must also be cooled sufficiently to harden the molding for ejection. As this requires the alternate heating and cooling of great masses of metal in the molding press, as well as the material itself, the process involves a considerably longer molding cycle than the injection process. Thus, it is not usually economical to mold small thin-section cold-set pieces by the compression process, but it is used commercially for the molding of large articles of thick section.

Compression molding of cellulose acetate materials and plastics requires adherence to the principles of molding that are similar to those previously recommended for compression molding of thermosetting materials.

### MOLDS AND MOLD DESIGN

The proper design of molds for fabricating plastic materials depends on many factors, including a knowledge of the molding materials and their behavior in the molding process. Other factors are strength of materials and knowledge of steels and their heat-treatment. This chapter will attempt no more than to point out to the designer the various types of molds, considerations that enter into their proper design, and the type of material to which each mold is particularly suited. Best results can be achieved only through consultation with a reliable molder for whose knowledge and experience no texts, tables, or rules can be substituted.

There are seven principal types of molds in use in the plastics industry. These are (1) the flash mold; (2) the landed plunger mold; (3) the loading plate mold; (4) the straight plunger mold; (5) the injection mold; (6) the transfer mold; and (7) the sub-

cavity mold. Because it is uneconomical in the use of molding material, the subcavity mold is not in common use.

The flash mold is the simplest to build and operate. It is, therefore, widely used. As shown in Fig. 8, this type of mold is characterized by a mold cavity the sides of which terminate sharply on a level with the top surface of the lower mold member. The plunger completely enters the mold cavity, forcing the

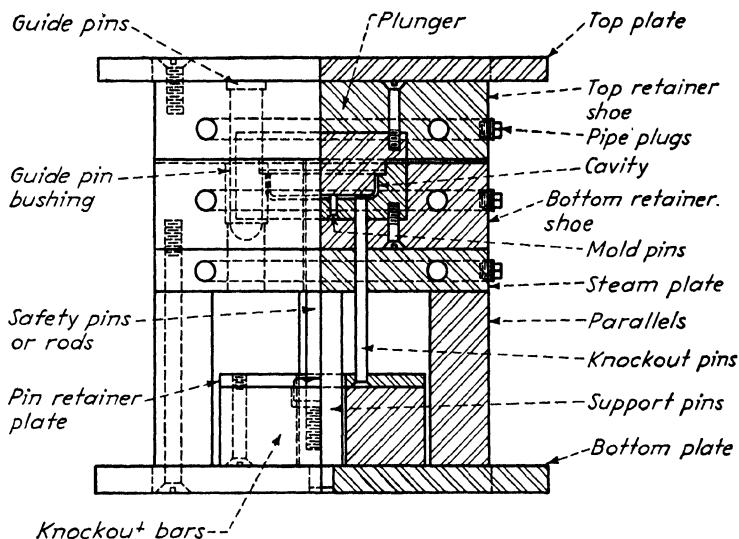

FIG. 8.—Cavity in a flash-type mold has sides which terminate sharply with the top surface of the lower mold member. Excess material is pinched off to a thin fin when the plunger has entered the mold cavity. These molds are simple to build and operate.

molding compound up the sides until the excess material is pinched off to a very thin fin, or flash, between the cutoff surfaces of plunger and cavity. The entire pressing force is supported by the horizontal meeting surfaces. It is wise to distribute this pressure over a larger area by leaving raised pads of approximately the same height as the cutoff surface.

When this type of mold is being designed, the following considerations must be kept in mind. Since the cured compound exerts relatively high frictional resistance to the opening of a mold, the top and bottom plates must be heavy enough and fastened securely enough to the mold parts to withstand the forces exerted by the pullback cylinders. Also, guide pins and

guide-pin bushings should be fastened securely. They must be so ground that they will position the two halves of the mold perfectly while allowing them to slip freely together.

The bottom steam retainer shoe should be provided with raised pads at the same height as the top of the cavity so as to distribute the pressure that otherwise would be concentrated on the cutoff surfaces of the mold cavity. Steam retainer shoes that frame the plunger and cavity should have the recesses that contain these members machined to exactly the same size so that the plunger and cavity may be ground at the same time.

The designer should check the mechanical stresses in all parts of the mold, paying especial attention to the distance between parallels and adding extra supports in case they are found necessary. Knockout bars should be checked to be certain that they will not bend under the stress of removing the molded part. Knockout pins with well-riveted heads should be fastened to this plate by the pin retainer plate. The holes in the plate should be enough larger than the pins that there will be an expansion allowance for the mold when heated. Steam lines should be placed beneath the cavity wherever possible but always around the cavity and plunger.

Cleanout slots should be provided between the top plate and the plunger retainer shoe, if mold pins must enter the plunger for proper line-up or for any other reason. Safety pins, used to prevent damage to knockout pins and mold cavities, push the knockout bar back into the molding position as the press closes. They should be large enough to withstand the mold-closing pressure. Finally, all assembly screws should be of such size that they will withstand the stresses set up in opening or closing the mold.

#### LOADING PLATE MOLDS

In cases where the design of a mold cavity is such that an unusually large space is required for the molding compound, it is more economical to use a loading plate mold as shown in Fig. 9, than to machine this space in the cavity. The loading plate rests on top of the bottom steam retainer shoe and the cavity, but is carried with the top mold member when the press opens, thus permitting the use of shorter knockout pins. Push rods are used to reset the knockout bar.

Guide pins should be long enough so that in closing they will pass through the loading plate and into the lower mold member before the plate comes in contact with the cavity. Loading plate molds must be so designed that when the mold is open, there is room for the press operator to work both between the plate and the bottom of the plunger and between the plate and the top of the cavity. The plate itself should be long enough to accommodate pushdown rods on each end.

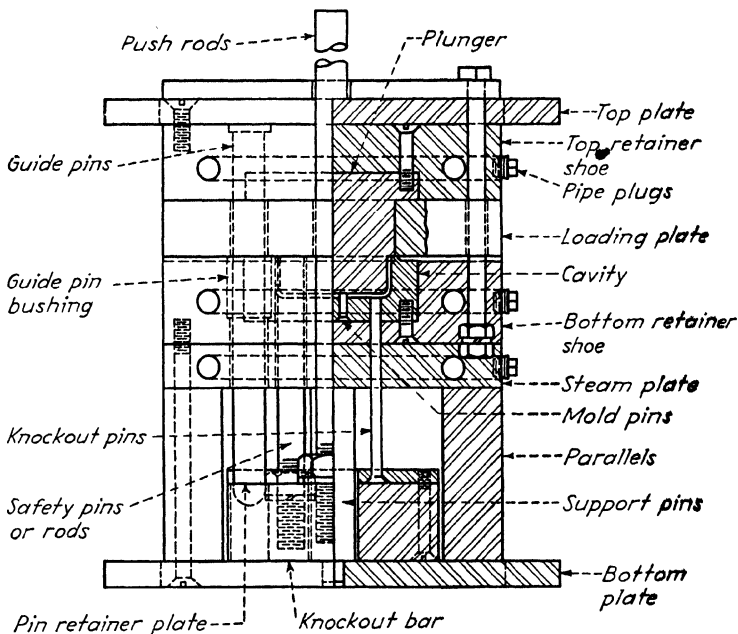

Fig. 9.—In the loading shoe-type mold the loading plate rests on bottom steam retainer shoe and the cavity. Push rods reset the knockout bar.

Landed plunger molds, Fig. 10, are very little different from flash molds. Whereas, in a flash mold the cutoff occurs at the upper level of the bottom mold member, in a landed plunger mold this cutoff occurs at a predetermined distance below the top of the cavity. Although some complications arise from excess molding material being trapped in the cavity, a passage can be provided to allow the excess to escape. It is sometimes best, however, to design the mold without these passages and later provide the size found necessary by actual trial in sampling.

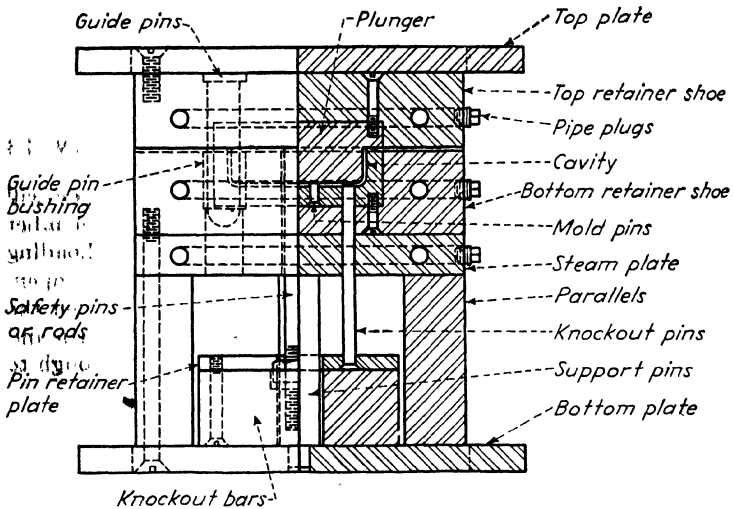

FIG. 10.—Accuracy of alignment of mold members makes the landed plunger mold especially suitable for parts with very thin sections.

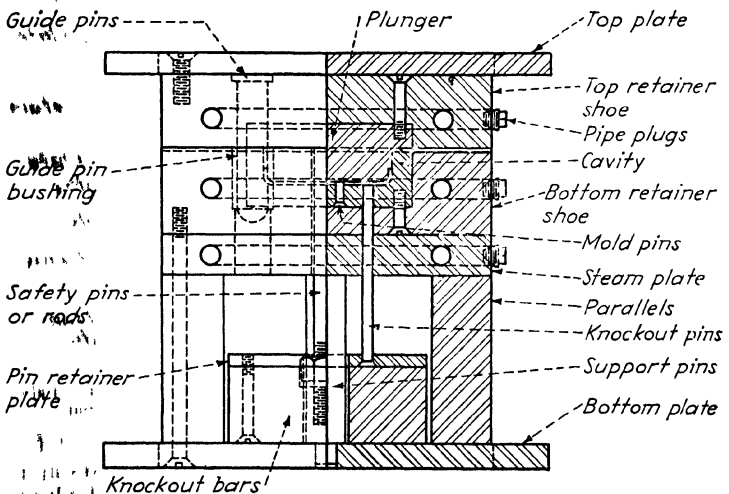

FIG. 11.—In a straight plunger mold the ram exerts full pressure on the molding compound, resulting in greater density in the product.

The landed plunger mold is especially adapted to the molding of parts with thin sections since the line-up of mold members is very accurate.

What has been said in the preceding paragraphs concerning flash-type molds and landed plunger molds can be said about straight plunger molds, Fig. 11, with the exception that in a straight plunger mold the plunger enters the cavity without resting on a land or horizontal cutoff. This construction causes full pressure to be exerted on the molding compound and results

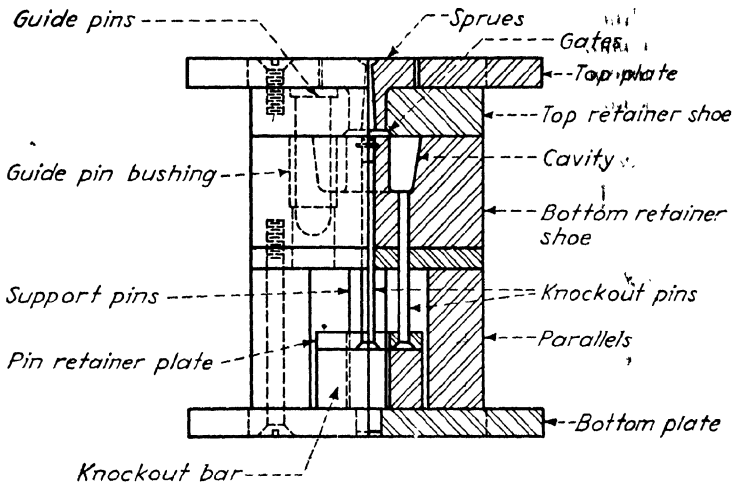

FIG. 12.—Because of the high pressures used, it is important that members of injection molding dies be perfectly finished and aligned.

in greater densification of molded parts. It also results in varying wall thicknesses, which may be objectionable.

### INJECTION MOLDS

Thermoplastic molding compounds are most economically molded in injection molds like that in Fig. 12. Such materials generally require much higher pressures than do standard compression-molding materials. The presses that are available for injection molding have such restricted spaces between strain rods that an entirely different technique must be employed in design of the molds. Among the many items to be considered are proper support to withstand the higher pressures, the correct design and placement of sprues and gates, interlocks where

line-up is important, and sufficient anchorage of movable mold members. In view of the extremely high pressures involved, it is especially important that the mold members should be properly lined up and that the butting surfaces of the meeting members should be perfectly finished. Because of this close fit, it is necessary to provide means for venting the air that would otherwise be trapped in the mold when it is closed in the press.

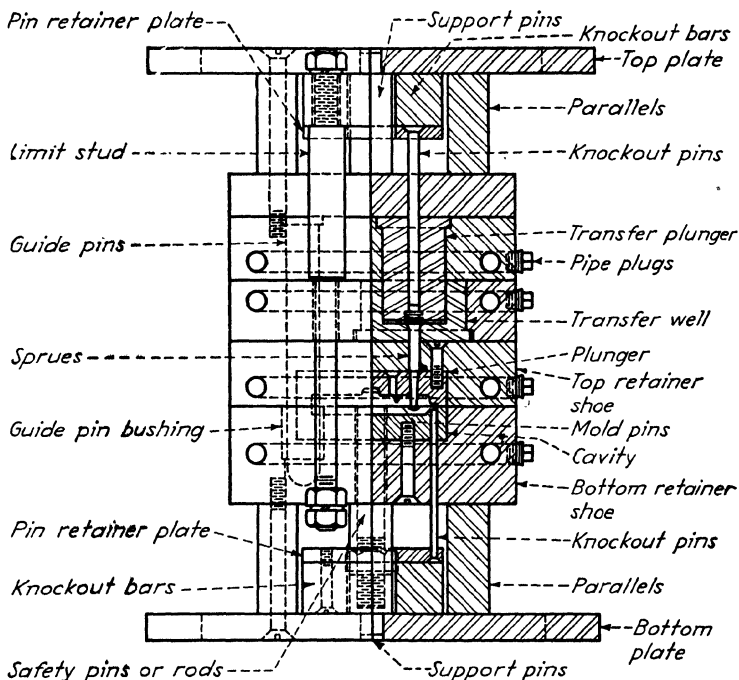

FIG. 13—Cleaning costs are low for plastic parts produced in transfer-type molds which inject heat-softened material into a heated mold.

### TRANSFER MOLDS

Transfer molding is similar in many respects to injection molding, but differs in that transfer molding is applied to the injection of a heat-softened thermosetting material into a heated mold, whereas injection molding is applied to the injection of a heat-softened thermoplastic material into a (normally) cold or chilled mold. Figure 13 shows an example of a transfer mold

with a transfer plunger entering the transfer well and with a limit stud. The advantages to be gained from the use of transfer molding are that cleaning costs on the molded parts are greatly reduced, more delicate inserts and pins may be used than would otherwise be possible, and closer tolerances on dimensions of the finished part can be met.

The molding compounds used in compression molding of plastics products have an abrasive action on the surfaces of the mold members. After a few hundred thousand parts have been molded in even the best of hardened steel molds, a perceptible amount of wear takes place. In order to reduce the wear caused by compounds and thus to lengthen the useful life of a mold, a fairly heavy chromium plate (0.001 to 0.002 in. generally is considered sufficient) is sometimes applied to all parts of the mold that come in contact with the compound.

An exception to this rule is the case in which it is desired that the molded parts either remain in the cavity or be extracted on the plunger when the mold is opened. In such cases, the molded part will remain on the mold member that is not plated. The advantages to be gained from the use of chromium plating are longer mold life because of greater hardness, greater abrasive resistance, greater corrosion or staining resistance, and decreased manufacturing cost of molded parts because the lower coefficient of friction allows easier extraction. The length of time required to "break in" a mold has been cut down by chromium plating. Worn mold members can be built up to the proper dimensions by chromium plating and will then usually outlast the original unplated mold.

### **DESIGN CONSIDERATIONS**

In the design of any of the previously mentioned molds, a number of items must be kept constantly in mind by the engineer. The type of molding material must be known, since any two or more materials that might be used might require different molding pressures and temperatures. These materials might require different shrinkage allowances to compensate for the decrease in size of the molded part when it is extracted from the mold.

Plastic molding materials vary in shrinkage from 0.001 to 0.008 in. per in., depending upon the nature of the material

(see Table 10). For example, plastic molding materials with mineral fillers will shrink less than the standard wood-flour filled materials. Before the mold is made, it is therefore necessary to know what material is to be used and the shrinkage figure for that material. Relative shrinkage figures may be obtained on specific materials. If the pieces are to be cooled in the mold under pressure, the allowance for shrinkage should be less than when they are removed hot. A standard wood-flour filled material will shrink 0.0035 to 0.004 in. per in. when cooled in the mold, against 0.006 to 0.008 in. per in. when pulled hot.

Heavy sections tend to shrink more than thin sections. A combination of thick and thin sections should be avoided because unbalanced stresses will be set up owing to the variation in shrinkage between the sections. This will cause the molded piece to warp or distort. For the same reason, a hole or depression in a piece should not approach too closely to the opposite face. A mark is likely to show because of uneven shrinkage.

The designer must know whether the molding material will be in bulk form or whether it will be compressed into a preform. The form of the molding material determines the loading space required. The location and the size of guide pins are based on the mold size and construction. As mentioned above, heating channels should be formed around the cavity and plunger and beneath the cavity. In all cases where the cavity is machined out of the same block as the steam retainer shoe, ample distance (at least  $\frac{5}{8}$  in.) should be allowed between the cavity walls and the heating channels. The design should be studied to determine the proper location for knockout pins, which should be ample in size and in number, to assure proper ejection of the molded part with little or no pin maintenance.

Mold pins, or projections in the mold that form holes in the molded part, should be checked for proper proportions. It is important that the lengths of slender pins do not exceed twice their diameter. Draft or tapered sides should be used where allowed by the design and in the largest amounts possible in order to facilitate extraction of the molded part. The necessity for and the location of pull pins and wedges should be determined. The desirability of making a mold member in sections or in one piece should be decided. Whatever else is done,

designs should be checked to be sure that it is possible to make the mold parts.

Another item for the designer's consideration is the steel to be used for the various mold parts. Past experience has gone far toward narrowing the field of suitable materials. Today there are only a few special steels that are being used. For hobbled mold cavities, a special grade of carbon-chrome-silicon steel is required for the hard, tough master or hob that is pushed into the equally special S.A.E. 3110 hobbing steel.

S.A.E. 3312 steel is used for machined parts of molds, both compression and injection. This steel, as well as the S.A.E. 3110 hobbing steel, must be casehardened after the parts have been finished to their final form in order to provide the necessary surface hardness and strength. In the casehardening furnace a case of 0.040 to 0.050 in. is applied to the mold parts and to test pieces that will subsequently be broken to check depth. Small mold pins are made of music wire; larger pins are made of drill rod.

It should be noted that the foregoing S.A.E. numbers are merely indications of the basic formulations of the steel used for molds. The steel manufacturers have done considerable work on improving the processing of these special steels and, as a result, the toolmaker has been given materials with better machinability, greater strength, better hardening properties, and more freedom from inclusions.

Molds, if poorly designed, can be a source of endless annoyance and loss to the molder. Properly designed molds will give high production over a long service life. A good background of practical experience in all the phases of the plastics molding business is one of the greatest assets of a mold designer.

## CHAPTER IV

### PRINCIPLES OF DESIGN

There is no mystery about plastics design. Good design with plastics is basically similar to good design with any material. From an engineer's viewpoint, plastics are relatively new materials of construction, possessing inherent advantages over other materials and also having certain limitations. As with any new

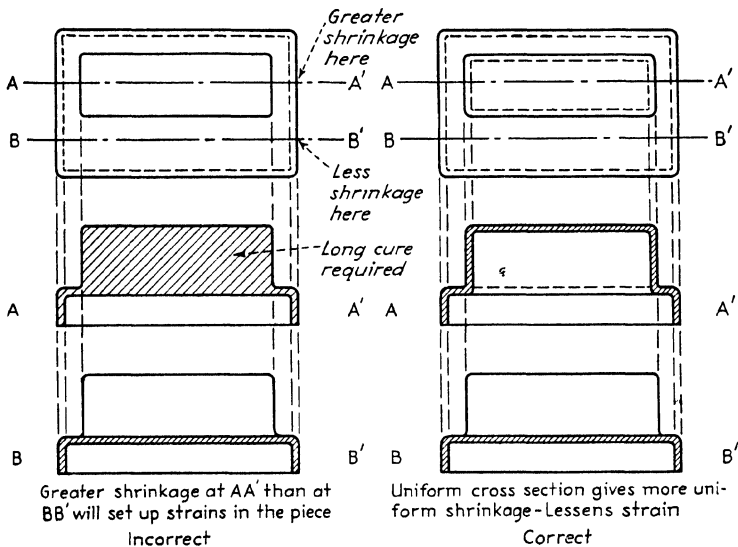

FIG. 14.—Effective design requires careful proportioning of material throughout the piece.

alloy or nonmetal that the engineer works with, plastics require the same intensive study before selection and the same care in design which takes into account the advantages and limitations of the material, its fabrication and finishing requirements, and its relative cost as a final product.

Once design requirements of size and shape, strength, particular properties, appearance, and cost are set, the choice of material

will depend on the ability of the material to meet those requirements and on the judgment of the engineer. In many cases plastics offer additional advantages in appearance, reduction

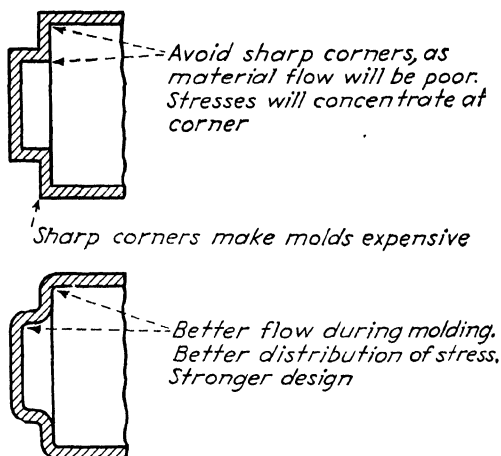

FIG. 15.—Sharp corners cause stress concentration, retard molding operation

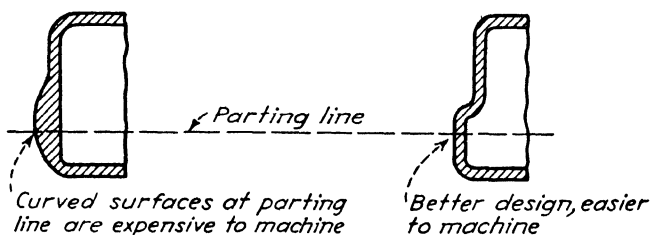

FIG. 16.—Mold parting lines should be placed for minimum of machining.

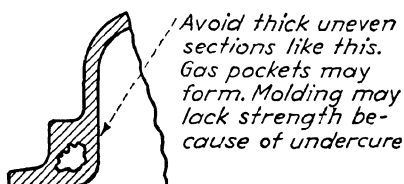

FIG. 17.—Avoid thick corners.

of assembly operations, and certain combinations of properties not available with other materials.

Previous chapters have pointed out briefly the comparative properties of the various plastic materials and have given some

details of the molding process. The comparative properties will indicate to a degree the proper material to select for a given application. Further details on specific materials will be found in those chapters on particular plastics. From the broad point of

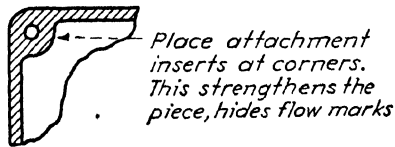

FIG. 18.—Inserts can readily be placed at piece corners.

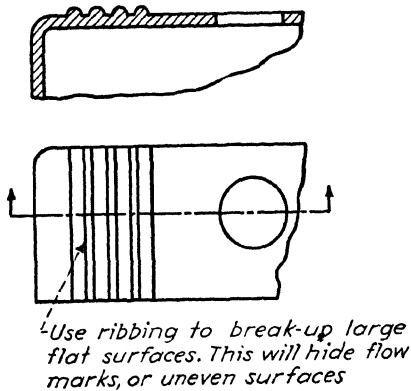

FIG. 19.—Ribs strengthen part, improve appearance.

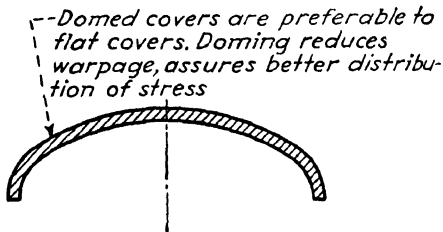

FIG. 20.—Doming of covers reduces warpage.

view, selection of plastic so far as properties are concerned follows the same procedure used with other materials, with this exception: testing under standard and operating conditions is most important. And cooperation with the material manufacturer and the molder will pay dividends in better designs.

Engineering comparison of production costs and product advantage will determine whether molded or laminated materials should be used. The method of molding will depend on specific design requirements and the choice of material. This chapter

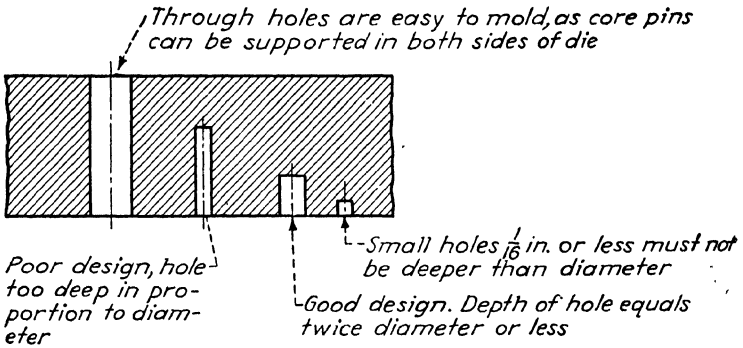

FIG. 21.—Size relationships for holes in molded parts.

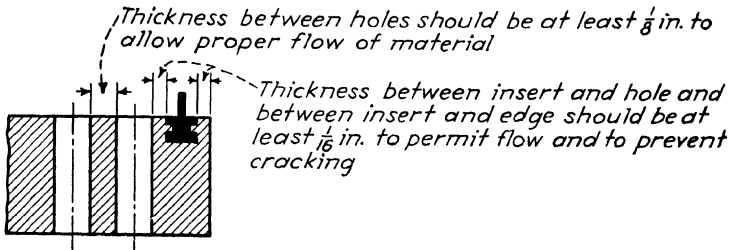

FIG. 22.—Location data for holes and inserts.

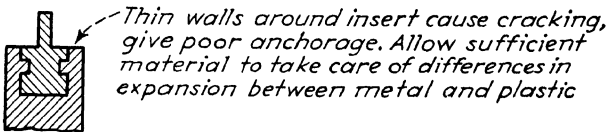

FIG. 23.—Allow ample material around inserts.

will concentrate particularly on proper design of molded plastic parts.

The first principle to remember is that the part is to be molded. Strangely enough, that is often forgotten until designs are well underway. The piece should be easily removable from the mold; otherwise, a complicated mold will be needed and produc-

tion costs increased. Proper simplicity in design will allow for simplicity in the mold and will reduce costs. Of course, complicated shapes can be produced, but production and mold costs are high, justifiably so in particular applications.

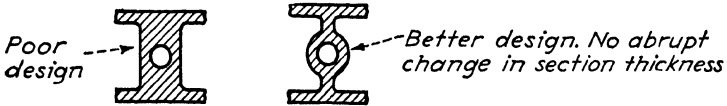
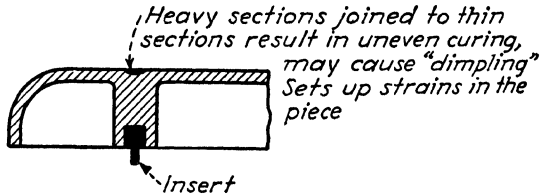

FIG. 24.—Method of placing insert in center of molded part.

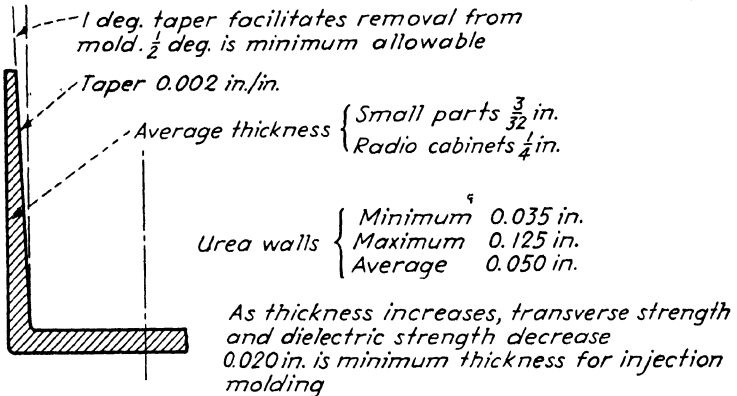

FIG. 25.—Wall taper and thickness data.

Tolerances, draft, inserts, parting lines, and shrinkage are all details that must be considered in connection with the molding process. Other factors that enter into proper design are wall thickness, fillets, fastening methods, threading, and finish. Machining is considered in a separate chapter.

### TOLERANCES

Vertical dimensions parallel to mold pressure require large tolerances, particularly if the mold is of the positive type. These dimensions are not so critical in the flash-type mold. There is

also the factor of mold shrinkage of the material, which will depend first on the mold design, the condition of the material used, and the molding technique, and secondly on the choice of material, the temperature and humidity conditions under which the part operates, and, in some cases, the loss of plasticizer through vaporization.

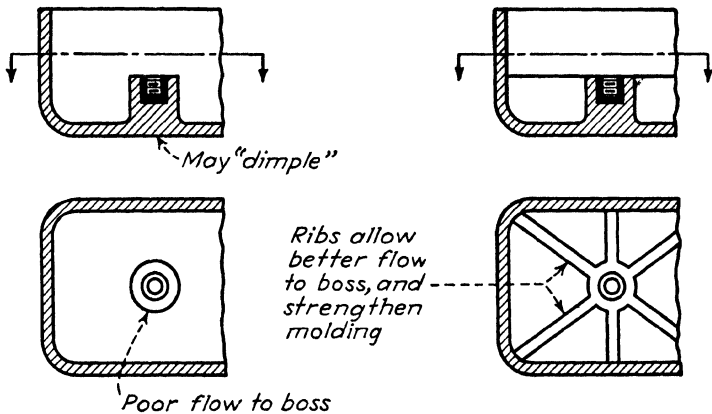

FIG. 26.—Proper design aids the molding operation.

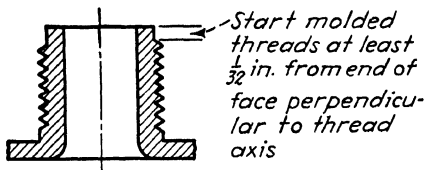

FIG. 27.—Threads can be successfully molded in.

Minimum tolerance of dimensions measured parallel to mold parting line is  $\pm 0.003$  in. per in., but a more practical tolerance is  $\pm 0.005$  in. per in.; at right angles to the parting line the minimum is  $+0.010$  in. and  $-0.000$  in.; a more practical tolerance is  $+0.015$  in.,  $-0.000$  in.

Rag-filled or coarse compounds require greater leeway in build-up dimensions (parallel with mold pressure), the minimum is  $+0.015$  in.  $-0.000$  in. More tolerance is allowed on large parts. Multiple cavity molds usually necessitate increased tolerances.

For warpage,  $\pm 0.003$  in. per in. from the average plane through the warped surface is a good working tolerance. All batches of each grade of compound should be uniform to ensure uniform shrinkage in molded part. Grinding or machining the finished part is sometimes the most economical procedure for obtaining close dimensional accuracy. On figuring tolerances where inserts are involved, attention should be paid to insert tolerances on the

minor or major diameter of thread, and tolerance between that portion of insert used for its location in mold and the working portion under consideration.

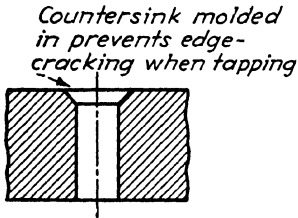

FIG. 28.—For tapped holes, countersink prevents cracking.

It is not always advisable to make the accuracy of the complete assembly dependent on the dimensions of the molded part. This is because the plastic molding may age and

slight changes in dimension may occur.

Although parts can be molded with little taper, the usual practice is to allow at least 1 deg. Three degrees is recommended;  $\frac{1}{2}$  deg. is the minimum. Proper draft allowance permits easy ejection from the mold.

### WALL THICKNESS

Proper thickness of wall is, of course, governed by requirements of mechanical strength or proper dielectric strength and insulation values. It is well to keep in mind the following general factors.

Use the minimum thickness possible, consistent with a satisfactory part. The thinner the section the faster the cure and the lower the cost of material. However, avoid too thin walls that are fragile. Eggshell construction will lead to rejects and failures in service. The wall thickness for average small parts is generally about  $\frac{3}{32}$  in. For larger parts, such as radio cabinets or instrument cases,  $\frac{1}{4}$  in. is used, occasionally reinforced with ribs.

Urea plastics may be used with minimum wall thickness of 0.035 in. and maximum wall thickness of 0.125 in., the average being 0.050 in. As the thickness of section increases, the transverse strength and dielectric strength decrease.

Walls of uniform thickness will reduce the possibility of uneven shrinkage and resultant stresses. If both thick and thin sections are necessary, it is good practice to core the thicker section to promote uniform curing. In the best design, thickness of section does not increase as it approaches the flash line.

Decreased section of side wall as shown in Fig. 25 helps in the molding operation since the material becomes denser and more tightly confined as the ram progresses. As the material flows up the side wall, the decreased thickness gives a wedging action which assists the molding pressure. Proper side-wall taper aids in easy release of the part after molding.

### FILLETS

As in casting design, fillets are advantageous in aiding flow, particularly of the thermosetting materials. They overcome structural weaknesses caused by stress concentration in sharp corners. Generous use of fillets will also serve to simplify the mold construction and will consequently reduce mold cost. And, as a further corollary, they strengthen the mold. The usual fillet radius is  $\frac{1}{32}$  in.

Rules governing fillets are more or less similar to regular engineering practice as exemplified in metal, sand, or die-casting. They are relatively easy to produce in the mold with milling cutters. Radii on the ends of fins are easy to machine in the mold.

Where materials are sluggish in flow or where deep moldings are involved, the use of generous fillets is highly recommended. There is one exception to this. Fillets should not be used at the parting line of the molded part. These corners should be squared off so that finishing is simplified and flash or fins can be removed readily by grinding or sanding.

### INSERTS

When using inserts, take into account such factors as (1) required mechanical strength of the insert in the plastic part; (2) tolerance on the position of the insert; (3) tolerance on the threads in the insert; (4) tolerance on the length of the projecting position of the insert; (5) required electrical characteristics of the insert in the plastic part; (6) molding material to be used; (7) method of molding to be used; (8) position of the insert in the

plastic part with relation to the manner of molding; (9) position of the insert in the plastic part with relation to the flow of material in molding; (10) amount of molded plastic around the insert; (11) general size and shape of the working portion of the insert; (12) material of which the insert is made; (13) methods of manufacturing the insert; (14) operations to be performed on the insert after molding; (15) effect of the insert on scrap loss during molding or assembly.

Rod inserts must be used with comparatively soft or free-flowing molding materials. Their use is restricted to injection-

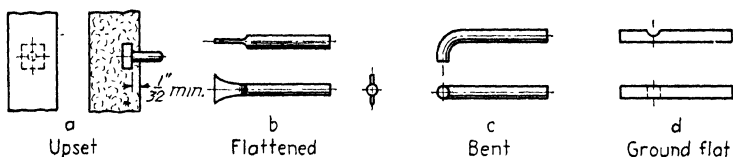

FIG. 29.—Typical rod inserts.

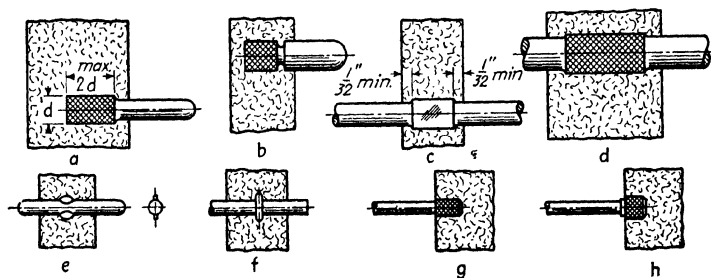

FIG. 30.—Machined rod inserts.

molded or transfer-molded articles or very favorable designs in compression-molded articles. Very little side flow of material under pressure can be permitted as the inserts will bend readily or even shear off. The insert in Fig. 29 *a* may also lift out of position owing to the flow of material. A hardened insert such as *d* may be so displaced in molding as to spring out of position when removed from the mold.

In the rod inserts, Fig. 30, *a* and *b* must be located from the projecting end and supported by the end during molding. Pressure may upset the insert to the size of hole in the mold, which, if slightly rough, will cause scoring on withdrawal. Flash or dirt in the hole will change the projecting length or, if the

inserts are supported by knockout pins, the length will vary because of variation in seating of the knockout bar. There is no general rule about length of insert imbedded in the plastic as this will depend upon the pull that the insert must stand, the molding material used, the insert material used, and the flow of material against the insert. In undercutting inserts, such as *b*, the undercut should be quite shallow and preferably in the knurled section. The depth of groove is quite satisfactory in

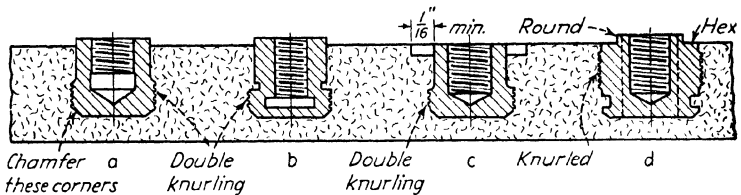

FIG. 31.—Threaded insert design.

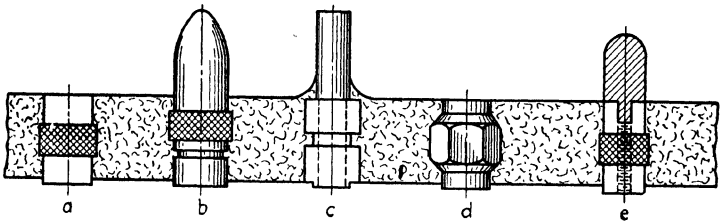

FIG. 32.—Knurled inserts.

most cases. In insert *d* the imbedded shoulders will provide anchoring against axial displacement. An insert such as *e* can be used in place of *c* or *d* frequently. This has the advantage that the stock used is of finished diameter. An upset insert such as *f* can also be used.

Where the projecting length of the insert is important, or where the surface must be kept free from scoring or flash, a shouldered insert such as *g* or *h* should be used. This should be chamfered as shown, as should all inserts, and may be undercut if desired.

Inserts with female threads should preferably extend above the molding surface. This is desirable, of course, as it helps support the insert in position at the same time that it prevents material flowing into the threads. Insert *c*, Fig. 31, results in rather weak mold construction and also requires concentricity

of center hole and shoulder as a pilot is ordinarily used in the threaded hole. Insert *d* should ordinarily have thick surrounding walls in thermosetting plastics to prevent cracking.

The amount of knurling will be governed largely by the cost of knurling. The extended portion of *a*, Fig. 32, and *d* will ordinarily be received by recesses in the bottom of the die while inserts *b* and *c* will ordinarily be piloted into the top member of the die. It is general practice to mold through inserts with

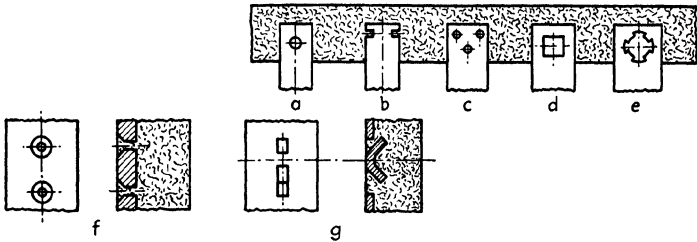

FIG. 33.—Methods of anchoring inserts.

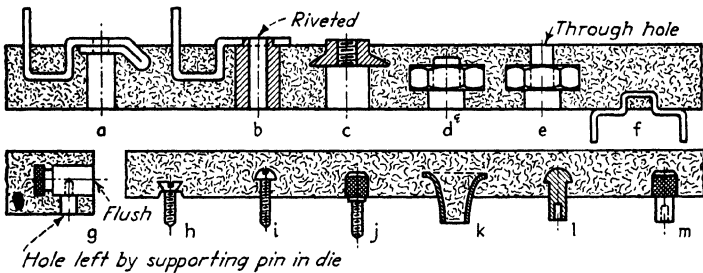

FIG. 34.—Punched, stamped, and formed inserts.

through holes. Holes may be retapped after molding to remove molded material or, as in *e*, a loose threaded pin may be used on the top side to enter the top member of the mold.

The holes *d* and *e* in Fig. 33 are rather expensive to obtain and present little or no advantage over types *a*, *b*, and *c*. Trouble will frequently be had with *f* in obtaining good anchorage as material will fill the holes and then continue to flow past, forming a flow or cleavage line of low strength.

Although many punched, stamped, or formed inserts are used, difficulty is usually experienced in holding them to proper size to fit the mold. Inserts with male threads may be similar to

Fig. 34, *h*, *i*, or *j*. Flathead or oval-head screws can be satisfactorily used when supported as in *h*. Roundhead screws used, as in *i*, are not very satisfactory as pressure on the head shortens the lead of the thread and molded material gets in the threads, necessitating a cleaning operation. Insert *j* is much more feasible because it eliminates both these defects. Avoid square or sharp corners, for the material will crack on shrinking.

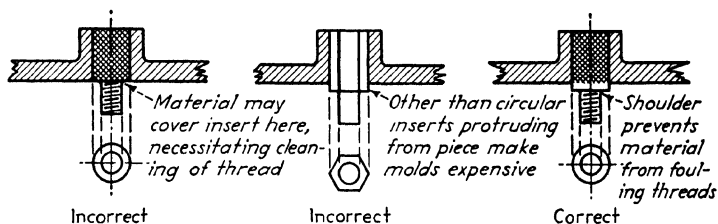

FIG. 35.—Correct and incorrect placement of inserts.

For spun-over inserts, eyelets such as *k* can sometimes be used, although rivets as *l* or screw machine inserts as *m* are to be preferred, *m* being most satisfactory on thermosetting plastics.

### THREADS

Threads may be molded in the part on an axis parallel to the mold stroke. Molded threads can be unscrewed from the steel cavity, or separate thread plugs may be used. With plugs, the complete molding is removed and the plug unscrewed while the molding production continues on the next piece.

On parts of undercut design where it is impractical to unscrew the molded piece from the mold, the parting can be made along the thread center line and a sizing die run over the thread to remove flash.

Threads should be started at least  $\frac{1}{32}$  in. from the end of face perpendicular to the axis of the thread. This will result in a stronger molding and will eliminate the possibility of a feather edge on the molded part. No more than 32 threads per in. should be specified. In small holes,  $\frac{3}{16}$  in. in diameter and less, which are to be tapped, the designer should provide a slight countersink in the molded piece. This will permit easy entrance and withdrawal of the tap and prevent cracking at the edges of the tapped hole.

TABLE 9.—LOCATION AND SIZE OF MOLDED HOLES\*

Min. hole diam., in.	Max. hole length, in.		Min. side wall, in., hot molded
	Blind hole	Straight through	
$\frac{1}{16}$	$\frac{1}{16}$	$\frac{1}{8}$	$\frac{1}{16}$
$\frac{5}{64}$	$\frac{3}{32}$	$\frac{3}{16}$	$\frac{1}{16}$
$\frac{3}{32}$	$\frac{1}{8}$	$\frac{1}{4}$	$\frac{1}{16}$
$\frac{7}{64}$	$\frac{5}{32}$	$\frac{5}{16}$	$\frac{3}{32}$
$\frac{1}{8}$	$\frac{3}{16}$	$\frac{3}{8}$	$\frac{3}{32}$
$\frac{5}{32}$	$\frac{1}{4}$	$\frac{1}{2}$	$\frac{3}{32}$
$\frac{3}{16}$	$\frac{5}{16}$	$\frac{5}{8}$	$\frac{1}{8}$
$\frac{7}{32}$	$\frac{3}{8}$	$\frac{3}{4}$	$\frac{1}{8}$
$\frac{1}{4}$	$\frac{7}{16}$	$\frac{7}{8}$	$\frac{1}{8}$
$\frac{5}{16}$	$\frac{9}{16}$	$1\frac{1}{8}$	$\frac{5}{32}$
$\frac{3}{8}$	$1\frac{1}{16}$	$1\frac{3}{8}$	$\frac{5}{32}$
$\frac{7}{16}$	$1\frac{3}{16}$	$1\frac{5}{8}$	$\frac{3}{16}$
$\frac{1}{2}$	$1\frac{5}{16}$	$1\frac{7}{8}$	$\frac{3}{16}$

\* Courtesy of General Electric Company.

### FASTENING

Various fastening methods are available to the engineer using plastic in his designs: inserts, tapped holes and standard screws, cored holes and self-tapping screws, through holes and rivets or eyelets, rivets, drilled holes and self-tapping screws, speed nuts, integral lugs. It is also possible to shrink parts together.

Selection of the method to be used will depend on many factors, including the type of plastic material, design of the part, assembly considerations, service expected, and relative cost.

Where cored holes are used, the designer will do well to follow the size limitations recommended in Table 9. Proper location of holes with respect to flow of material during molding is important.

With thermosetting materials, standard tubular rivets can be molded in the plastic part and then spun over to fasten the plastic part to metal sections. In one electrical application this type of connection for a contact arm is used. Some trouble was experienced with looseness and poor electrical qualities in the point. This was remedied by soldering after spinning over the rivet.

With thermoplastic materials, it is possible to mold an integral lug on the plastic part. After the lug is placed through a drilled hole in the metal section to which the plastic part is attached, the tip of the lug is heated and flowed over to form a head. Hinges can be formed over wire hinge pins by the application of heat and pressure. In one design using acetate-butyrates, the handle of a wire stitcher is attached to the metal slide by forming

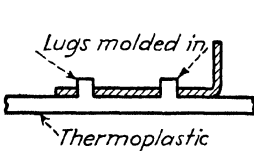

FIG. 36.

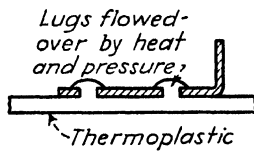

FIG. 37.

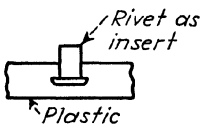

FIG. 38.

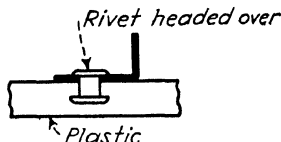

FIG. 39.

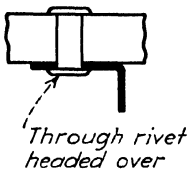

FIG. 40.

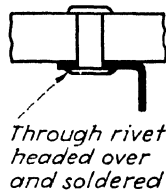

FIG. 41.

FIGS. 36-41.—Six methods of fastening.

over with heat (see Fig. 43). With cellulose acetate-butyrates, pins can be driven directly into or through the plastic because of its toughness.

Speed nuts are a recent development that show certain advantages in assembling plastics. These patented devices are snapped over lugs or bosses provided on the molded part (see Fig. 46). The speed nut maintains spring tension on the parts and bites deeply into the plastic or the metal, thus reducing the possibility of the joint's loosening under vibration.

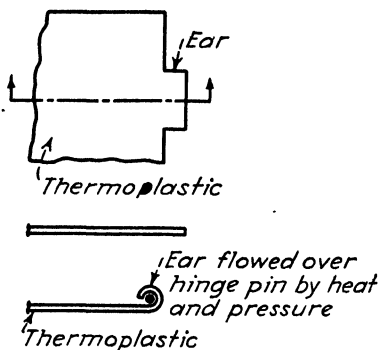

FIG. 42.

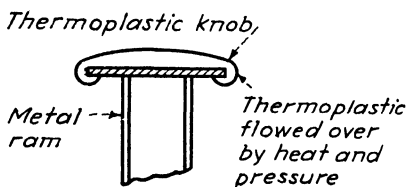

FIG. 43.

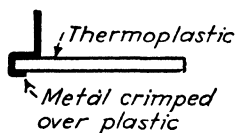

FIG. 44.

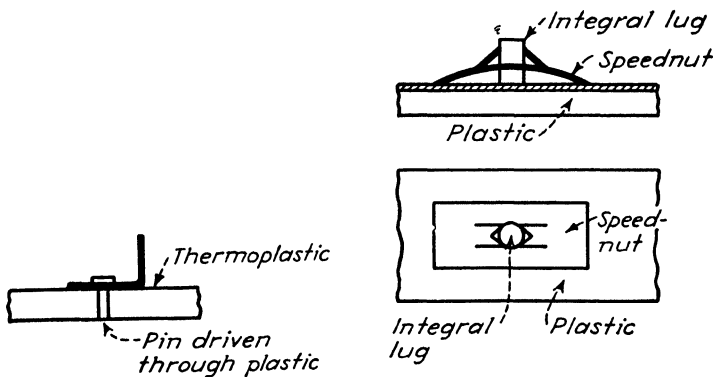

FIG. 45.

FIG. 46.

FIGS. 42-46.—Other fastening means for plastic parts.

TABLE 10.—AVERAGE MOLD SHRINKAGE

	Inches per Inch
Phenol formaldehyde:	
Wood-flour filled . . . . .	0.008
Mineral-filled . . . . .	0.004
Fabric-filled . . . . .	0.005
Phenol furfural:	
Wood-flour filled . . . . .	0.007
Mineral-filled . . . . .	0.004
Fabric-filled . . . . .	0.004
Urea formaldehyde . . . . .	0.008
Vinyl chloride . . . . .	0.001
Vinylidene chloride . . . . .	0.006
Polystyrene . . . . .	0.005
Methyl methacrylate . . . . .	0.004
Cellulose acetate . . . . .	0.005
Cellulose acetate-butyrate . . . . .	0.005
Ethyl cellulose . . . . .	0.005

TABLE 11.—AVERAGE THERMAL EXPANSION

	Inches per Inch per Deg. C.
Phenol formaldehyde:	
Wood-flour filled . . . . .	$5.5 \times 10^{-5}$
Mineral-filled . . . . .	3.2 " "
Fabric-filled . . . . .	4 " "
Phenol furfural:	
Wood-flour filled . . . . .	3 " "
Mineral-filled . . . . .	2 " "
Fabric-filled . . . . .	5 " "
Urea formaldehyde . . . . .	3 " "
Vinyl chloride . . . . .	7 " "
Vinylidene chloride . . . . .	16 " "
Polystyrene . . . . .	7 " "
Methyl methacrylate . . . . .	8 " "
Cellulose acetate . . . . .	12 " "
Cellulose acetate-butyrate . . . . .	13 " "
Ethyl cellulose . . . . .	12 " "

CHAPTER V  
**COMMON FAULTS, CAUSES, AND REMEDIES IN  
 MOLDED PLASTICS PARTS\***

**PHENOLICS AND UREAS—COMPRESSION MOLDING**

Condition of piece	Probable cause	Possible remedy
I. Pieces blistered	1. Molding cycle too short 2. Air or gases trapped in mold  3. Material has absorbed water due to exposure 4. Mold too hot 5. Insufficient pressure  6. Mold too cold 7. Mold charge too bulky, contains too much air  8. Nonuniform heating	1. Increase time of cycle 2. a. Close mold more slowly b. Provide sprue grooves to allow escapement of gas c. Preheat† material 3. Preheat† material  4. Reduce temperature 5. Increase pressure, or adjust powder weights if multiple-cavity mold is used 6. Increase temperature 7. Preform material, or distribute in most suitable manner to allow air to escape. If powder, arrange in a pile similar to a mountain peak, rather than a volcano 8. Rearrange steam channels, or place mold in press in a way to promote uniformity of heating

\* Copyright by Bakelite Corporation, New York. Reproduced by permission.

† Preheat: 180 deg. F. (82 deg. C.) to 225 deg. F. (107 deg. C.) for 20 min. to 1 hr. Material should be loaded hot wherever possible.

Condition of piece	Probable cause	Possible remedy
I. (Continued)	9. Piece designed with thick nonuniform walls	9. a. Tablet the charge b. Preheat† material c. Reduce molding temperatures
II. Parting line porous but bottom and flash thick. Finish good where piece is properly filled out and pressure directly on it	1. Material too hard. Does not flow freely 2. Pressure insufficient 3. Mold too hot resulting in precuring 4. Mold closed too slowly, resulting in precuring 5. Mold charge too great to allow proper escapement and closing of the mold	1. Use a softer material 2. Increase pressure 3. Lower temperature 4. a. Increase speed of closing by more rapid supply of pressure b. Preheat† material 5. Adjust charges properly or provide sprue grooves for escapement
III. Appearance as in II but bottom and fins of proper thickness	1. Charge is insufficient 2. Mold is closed too fast, splashing material from mold 3. Mold allows too fast escapement of material	1. Increase charge to proper weight 2. Close more slowly, permitting material to soften and flow properly 3. a. When a flash mold is used, increase width of cutoff b. Where fit is poor between mold parts, it must be corrected c. Use a harder material d. Use abnormal charge of material
IV. Molded piece is flexible on discharge	1. Piece is insufficiently cured 2. Material has absorbed water due to exposure 3. Too much lubricant is used on mold, causing the material to be plasticized	1. a. Increase curing cycle b. If temperature is too low raise it 2. Preheat† material 3. Do not use lubricant

† Preheat: 180 deg. F. (82 deg. C.) to 225 deg. F. (107 deg. C.) for 20 min. to 1 hr. Material should be loaded hot wherever possible.

Condition of piece	Probable cause	Possible remedy
V. Molded piece sticks or adheres to mold	1. Temperature too high and resin fails to come to surface and cover it. (Common with mineral-filled material.) 2. Mold fouled by improper lubricant or previous materials. Phenolic material will stick after cellulose acetate has been used when molds are not chromium plated	1. Reduce temperature  2. Clean surface of mold and polish
VI. Surface of piece dull	1. Mold too hot or too cold 2. Mold improperly polished 3. Mold stained by previous material 4. Poor grade of steel used for mold	1. Correct temperature 2. Polish mold 3. Clean and polish mold 4. Polish and chromium plate
VII. Surface of piece orange peeled	1. Mold closed too fast under too high pressure 2. Material too soft 3. Material too coarse 4. A number of preforms used for charge 5. Material contains excessive moisture	1. <i>a.</i> Close mold more slowly <i>b.</i> Preheat † material and load hot 2. Use a harder material, or preheat † and load hot 3. Use a finer material, or preheat and load hot 4. <i>a.</i> Use one preform or place preforms far apart and close mold slowly <i>b.</i> Preheat † material 5. Preheat † material
VIII. Surface of piece pitted or has small fissures	1. Material contains foreign matter, particularly oil or grease	1. Protect material against contamination

† Preheat: 180 deg. F. (82 deg. C.) to 225 deg. F. (107 deg. C.) for 20 min. to 1 hr. Material should be loaded hot wherever possible.

Condition of piece	Probable cause	Possible remedy
IX. Surface of piece clouded and/or color segregated	1. Mold too hot, causing precuring 2. Material too hard and/or pressure too low 3. Material too soft	1. <i>a.</i> Reduce mold temperature <i>b.</i> Tablet the charge 2. Increase pressure and/or use softer material 3. Use harder material
X. Surface of piece has inverted blisters similar to dimples	1. Mold closed too fast 2. Material too soft (common) 3. Too little charge or too much leakage	1. Close mold more slowly 2. <i>a.</i> Use a harder material <i>b.</i> Reduce temperature which increases viscosity of flow 3. <i>a.</i> Increase charge <i>b.</i> Slower closing of mold <i>c.</i> Use stiffer material <i>d.</i> Preform to more accurately approximate shape of piece
XI. Pieces warped	1. Mold heated nonuniformly 2. Material too soft 3. Insufficient cure 4. Mold too hot, causing casehardening of piece 5. Piece of irregular wall thickness and shape resulting in complex flow, cure, and shrinkage 6. Charge left too long in mold before closing	1. Correct heating methods 2. Use harder material and/or preheat† material 3. Increase cycle 4. Decrease temperature 5. <i>a.</i> Use lower shrinkage material <i>b.</i> Adjust temperature of various parts of mold accordingly <i>c.</i> Preheat† material and load hot <i>d.</i> Redesign piece to uniform section 6. Faster closing

† Preheat: 180 deg. F. (82 deg. C.) to 225 deg. F. (107 deg. C.) for 20 min. to 1 hr. Material should be loaded hot wherever possible.

Condition of piece	Probable cause	Possible remedy
XI. (Continued)	7. Molding placed where it cools very unevenly; <i>i.e.</i> , on cold metal plate 8. Material has absorbed moisture due to exposure 9. Pieces cooled nonuniformly (one side cooling faster than the other after molding)	7. a. Provide means for uniform cooling b. Provide shrink fixtures 8. Preheat† material and load hot or cold 9. Cool uniformly
XII. Pieces crack at once or afterward in storage	1. Wall around inserts too thin 2. Pieces strained on ejection 3. Shrink plugs too large 4. Where piece is cooled too much in mold, strains are set up	1. Increase wall and/or use lower shrinkage material 2. Eject evenly 3. Correct plugs, mold, and/or use lower shrinkage material 4. Reduce cooling cycle
XIII. Pieces have poor electrical properties	1. Pieces casehardened owing to too rapid closing of mold and too high temperature 2. Material has absorbed moisture 3. Pieces undercured 4. Foreign matter in material	1. a. Close mold more slowly b. Preheat† material and load hot c. Reduce temperature 2. Preheat† material 3. Increase curing cycle 4. Protect against contamination
XIV. Pieces weak mechanically and have poor chemical resistance, particularly to water and solvents	1. Pieces undercured generally owing to too low temperature 2. Pressure not sufficient on piece, a common fault where charge is just too low, escapement too great, or pressure is absorbed by abnormal landed area on mold	1. Increase temperature and cycle. 2. Increase pressure and/or charge.

† Preheat: 180 deg. F. (82 deg. C.) to 225 deg. F. (107 deg. C.) for 20 min. to 1 hr. Material should be loaded hot wherever possible.

Condition of piece	Probable cause	Possible remedy
XIV. ( <i>Continued</i> )	3. Time of cure too short	3. Increase time of cure
XV. Surface has hard small spots on pieces similar to small blisters, commonly known as pimples	1. Material contains foreign matter, particularly wood splinters, or metal chips 2. Material has hard particles in it and/or is too coarse	1. Protect against contamination 2. Use softer and/or finer material

### CELLULOSE ACETATES, POLYSTYRENES, AND VINYL MATERIALS —INJECTION MOLDING

NOTE: When the cause, remedy, or condition pertains to cellulose acetate, it is prefixed A.O. (acetate only); if only to polystyrene, it is prefixed S.O.; and if only to vinyl, it is prefixed V.O.

Condition of piece	Probable cause	Possible remedy
1. Pieces short, not filled	1. Material too cold  2. Injection pressure too low  3. S.O. Sprues, runners, or gates too small	1. a. Increase temperature of heating cylinder. In all cases, however, care should be taken not to exceed the maximum recommended temperature b. Increase over-all time cycle c. Increase temperature of mold 2. a. Increase pressure b. Increase time of full pressure application c. Back electrical resistance heating element may be burned out causing lower effective pressure on account of unplasticized granules 3. S.O. Increase size to increase effective pressure on casting

Condition of piece	Probable cause	Possible remedy
<p>I. (Continued)</p>	<p>4. Feed insufficient</p> <p>5. Feed too heavy causing choking of effective pressure by hard unplasticized granules</p> <p>6. A.O. Material too hard</p> <p>7. Resistance caused by back pressure of entrapped air (usually marked by burning around unfilled portion)</p> <p>8. Nozzle orifice constricting flow.</p>	<p>4. a. Increase feed until plunger is <math>\frac{1}{8}</math> in., or less, from maximum stroke</p> <p>b. S.O. Heat plasticized material choking feeding device. Run more cold water through feed cooling sleeve</p> <p>5. a. Reduce feed until plunger is <math>\frac{1}{8}</math> in., or less, from maximum stroke on injection</p> <p>b. A.O., S.O. Pre-heat material as much as possible without sintering</p> <p>6. a. A.O. Use softer material</p> <p>b. Use more free flowing formulation</p> <p>7. a. Vent cavities</p> <p>b. Use slower speed of injection</p> <p>c. Set dies so they have 0.0015 in. clearance when closed</p> <p>d. Install vacuum system to evacuate the mold when economically feasible</p> <p>8. a. Remove contamination</p> <p>b. Use larger nozzle orifice</p> <p>c. Ream out orifice if flanged over</p>

Condition of piece	Probable cause	Possible remedy
I. (Continued)	9. Cold slug clogging runners or gates or sprue  10. Material oozing out of nozzle faster than rate of feed  11. Die too cold	9. a. Increase size of cold slug at knockout pin b. Provide a teat at end of straight runner c. Pull nozzle away from sprue bushing on each stroke  10. Reduce temperature, use smaller nozzle  11. a. Reduce flow of cooling water b. Heat die by electrical resistance heaters or flow of hot oil, water, or steam
11. Mold flashes	1. Material too hot  2. Injection pressure too high 3. Poor adjustment of dies  4. Flash or foreign matter acting as high spot on land 5. Projected area of piece too large for available die holding pressure	1. a. Reduce temperature b. Decrease over-all time cycle when possible c. Reduce pressure temporarily until proper temperature is maintained  2. Reduce pressure  3. Correctly reset toggle and die adjustment  4. Remove  5. a. Shift to larger press b. Reduce size of land area c. Reduce number of cavities d. Reduce thickness of cross section of piece if possible

Condition of piece	Probable cause	Possible remedy
II. (Continued)	6. Poor mitering of die and cavities	6. Remiter die and cavities
III. Pieces warp on or after ejection	1. Piece binding or sticking in die	1. Polish die, use lubricant, check pressure
	2. Undercuts on die too deep	2. A.O. Reduce depth of undercut
	3. Knockout pins work unevenly	3. Repair
	4. Moldings too hot on ejection	4. a. Reduce mold temperatures
		b. Increase cooling time
		c. Reduce temperature of heating cylinder
		d. A.O. Use faster setting, more rigid material
		e. Use shrink blocks
	5. Heavy sectioned moldings distort on standing	5. a. Immerse in cold water immediately after ejection
		b. Increase molding cycle
		c. Molding temperature too low causing stress due to internal strain. Increase temperature of heating cylinder
	6. Gate design and location	6. Redesign or relocate so as to provide minimum stress
IV. Sink or shrink marks on moldings	1. Caused by thermal contraction of material on cooling	1. a. Increase effective pressure on piece, runner, and sprue by (1) opening gate; (2) heating mold; (3) increasing pressure; (4) increasing size of runner

Condition of piece	Probable cause	Possible remedy
IV. (Continued)	2. Insufficient material shot into cavity  3. A.O. Material not free flowing  4. Piece ejected too hot	b. Redesign part with thinner section c. Increase piston dwell interval 2. a. Increase length of time pressure applied on injection stroke b. Increase feed 3. A.O. Use more free-flowing material design to reduce surface shrinkage 4. a. Increase cooling time b. Reduce temperature of die c. Immerse in cold water immediately after ejection
V. Flow marks on molding	1. Material too hot 2. Material too cold  3. Too much lubricant on die  4. A.O., S.O. Material contains too much moisture 5. Die too cold 6. Runners and gates too small, cooling material 7. Water or liquid on die surface	1. See condition II, 1 2. a. Raise temperature of heating cylinder b. Increase cycle 3. Use less lubricant; prevent sticking by polishing die, checking pressure 4. A.O., S.O. Preheat material 5. See condition I, 11 6. Open gates and runners 7. a. Wipe mold surface clean b. Moisture condensing because die too cold c. Stop leakage from external source

Condition of piece	Probable cause	Possible remedy
V. (Continued)	8. Contamination due to foreign material	8. a. Inspect molding material for contamination and replace b. Remove and clean feed device and hopper
	9. A.O. Material too fast setting	9. A.O. Use free-flowing material
	10. Cold slug	10. See condition I, 9
	11. Material burning in heating cylinder	11. Reduce temperature of heating cylinder even if cycle must be increased
	12. Material of incorrect formulation	12. Use appropriate formulation
VI. Stars or mica specks on surface	1. A.O., S.O. Material contains too much moisture	1. a. A.O., S.O. Pre-heat material b. Increase effective pressure
	2. Contamination with other materials	2. a. Inspect molding material b. Remove and clean feed device and hopper
	3. Material too hot	3. Reduce temperature
	4. Gate and runners too small	4. Increase size
	5. Water or oil on dies	5. Wipe clean and repair leak
	6. Too much lubricant on die	6. Do not use lubricant—prevent sticking by same method given in condition V, 3
VII. Surface lamination	1. Contamination with other molding materials	1. a. Inspect molding material b. Remove and clean hopper and feed device
	2. A.O., S.O. Too much moisture in material	2. A.O., S.O. Preheat material
	3. Material too cold	3. Increase temperature of heating cylinder

Condition of piece	Probable cause	Possible remedy
VII. (Continued)	4. Too slow speed of injection 5. Too small gate, sprue, and runners 6. Water and oil getting into material or sprue, runners, or cavity 7. A.O., S.O. Dies too cold	4. Increase rate of injection when possible 5. Increase size 6. Repair leakage or remove source of contamination 7. A.O., S.O. Increase temperature of dies
VIII. Poor welding	1. Material too cold 2. Mold too cold 3. Effective pressure on piece too low 4. Distance from gate to weld joint too long 5. Water or lubricant on surface of mold 6. Material too hot 7. A.O. Material unsuitable	1. Increase temperature of heating cylinder 2. Increase temperature of mold 3. a. Increase pressure b. See condition I, 2, 3, 4, 5, 7, 8, 9, 10 4. Use multiple gates and runners 5. Check condition and use some other method in condition V, to eliminate sticking 6. Reduce temperature of heating cylinder slightly 7. A.O. Use a welding formulation material
IX. Bubbles in molding	1. Usually caused by internal shrinkage, due to thermal contraction after case-hardening of outer layer of material	1. a. Increase effective pressure on castings by (1) heating mold; (2) increasing pressure; (3) increasing size of gates, runners, sprues, and nozzle; (4) increasing cycle; (5) fast rate of injection b. Use lower temperature in heating cylinder

Condition of piece	Probable cause	Possible remedy
IX. (Continued)	2. Material too hot 3. Improper venting, causing air entrapment 4. A.O. Material too quick setting 5. Piece cooled in mold too long 6. Dies too cold 7. Moisture condensation on cold mold surfaces between cycles due to excessively high humidity	2. Reduce temperature of heating cylinder 3. a. Vent mold b. If economically feasible, use vacuum pump to remove air 4. A.O. Use special low shrink material 5. Shorten cooling cycle. This will eliminate bubbles but tends to cause warpage and sink marks 6. Heat mold 7. Decrease amount of coolant circulating through mold or, better yet, use controlled humidity air in molding room
X. Rough grainy surface	1. Material too cold 2. Die too cold 3. A.O. Too soft material 4. Poor die surface 5. A.O., S.O. Pressure too great	1. Raise temperature of heating cylinder 2. Increase temperature of die 3. A.O. Use harder plasticity material 4. Polish die 5. A.O., S.O. Reduce pressure
XI. Seam lines on heavy section	1. Dies too cold 2. Material too cold 3. A.O., S.O. Too great pressure 4. Lubricant or water on dies 5. Too slow or too fast rate of injection	1. Increase temperature of dies 2. Increase temperature of heating cylinders 3. A.O., S.O. Reduce pressure, but will probably cause sink marks 4. Check condition and use some other method in condition V, 3 to eliminate sticking 5. Adjust rate of injection

Condition of piece	Probable cause	Possible remedy
XI. (Continued)	6. Improper venting 7. Gate and/or runners too small or in incorrect location	6. Vent mold properly 7. Enlarge as indicated or relocate
XII. Molding weak or brittle	1. Material too cold, improper molding  2. Too small gates, runners, or sprues 3. Too low pressure 4. Material too hot, thus breaking down molecular structure  5. V.O., A.O. Material too hard or improper for use  6. Contamination with other materials  7. Dies too cold for proper molding 8. Design of molding with too thin sections	1. Increase temperature of heating cylinder 2. Increase size 3. Increase pressure 4. a. Reduce temperature of heating cylinders b. Increase size of shot to decrease time material kept under high heat in cylinder 5. V.O., A.O. Use softer formulation or change type of material 6. a. Check molding material b. Remove and clean feed device and hopper 7. Increase temperature of dies 8. Change design of mold
XIII. Cloudy surface on molding or cloudy appearance of transparent moldings	1. Contamination  2. Material temperature too low  3. External lubricants contaminating surface  4. A.O., S.O. Too high moisture content of material	1. a. Inspect molding material b. Remove and clean feed device, hopper, and cylinder 2. Increase temperature of heating cylinder 3. Clean, polish die. Check draft. Check pressure, temperature 4. A.O., S.O. Preheat well before using

**CELLULOSE ACETATES AND VINYL MATERIALS**  
—COMPRESSION MOLDING

Condition of piece	Probable cause	Possible remedy
I. Pieces short, not quite filled	<ol style="list-style-type: none"> <li>1. Insufficient material</li> <li>2. Press closed too fast, flashing out material</li> <li>3. Low apparent density, restricting charge weight</li> </ol>	<ol style="list-style-type: none"> <li>1. Increase charge</li> <li>2. Determine correct rate of closing on low pressure and application of high pressure</li> <li>3. Adjust charge</li> </ol>
II. Pieces warp on ejection	<ol style="list-style-type: none"> <li>1. Binding in die</li> <li>2. Pieces too hot</li> <li>3. Pieces distorted by handling</li> </ol>	<ol style="list-style-type: none"> <li>1. Clean, polish die</li> <li>2. Increase cooling time</li> <li>3. <ol style="list-style-type: none"> <li>a. Increase set time</li> <li>b. Use shrink blocks</li> <li>c. Chill in cold water</li> </ol> </li> </ol>
III. Sink or shrinkage marks on pieces	<ol style="list-style-type: none"> <li>1. Insufficient material and lack of pressure</li> <li>2. Material too hot</li> <li>3. A.O. Influenced by volatile content of material</li> <li>4. Caused by thick section in molding</li> <li>5. Material too soft</li> <li>6. Cooling rate too slow or uneven over entire mold area</li> </ol>	<ol style="list-style-type: none"> <li>1. <ol style="list-style-type: none"> <li>a. Increase charge</li> <li>b. Check closing operation</li> <li>c. Increase pressure</li> </ol> </li> <li>2. Reduce heating cycle or adjust temperature</li> <li>3. A.O. Preheat material</li> <li>4. Redesign piece</li> <li>5. Use harder material</li> <li>6. Increase cooling rate. If rate is uneven, repipe coolant lines or redesign mold to give even cooling</li> </ol>
IV. Flow marks on pieces	<ol style="list-style-type: none"> <li>1. Material either too hot or cold</li> <li>2. A.O. Influenced by volatile content of material</li> <li>3. Material too soft</li> </ol>	<ol style="list-style-type: none"> <li>1. Adjust temperature and cycle</li> <li>2. A.O. Preheat material</li> <li>3. Use harder material</li> </ol>
V. Pock marks, dimples on pieces	<ol style="list-style-type: none"> <li>1. A.O. Volatile content of material too high</li> <li>2. Temperature too high</li> </ol>	<ol style="list-style-type: none"> <li>1. A.O. Preheat material</li> <li>2. Adjust temperature and cycle</li> </ol>
VI. Pieces cloudy and mealy appearance	<ol style="list-style-type: none"> <li>1. Material too cold</li> </ol>	<ol style="list-style-type: none"> <li>1. Increase temperature and adjust cycle</li> </ol>
VII. Pieces brittle	<ol style="list-style-type: none"> <li>1. Material either too hot or too cold</li> <li>2. Material too hard or</li> </ol>	<ol style="list-style-type: none"> <li>1. Adjust temperature</li> <li>2. Change to softer</li> </ol>

## CHAPTER VI

### MACHINING AND FINISHING PLASTIC PARTS

One of the advantages of the use of molded plastics is that machining and finishing operations are almost entirely eliminated. Die castings enjoy similar advantages over machined and formed parts. Laminated plastics, available in sheet or tube form, are however usually machined to the shape and size desired. On molded parts flash or fins, gates and sprues must be removed.

The term "finishing" is broadly used to cover those operations subsequent to or supplementing the actual molding or fabricating processes. After molding plastics are first subjected to rough finishing to remove flash from the parting line and from the openings in the molded pieces. Drilling and tapping operations, together with any other necessary machining, follow, after which a final buffing or polishing produces the desired finish.

Sprue marks on injection-molded items often have to be removed by hand filing. This must be done carefully so as not to mar the finish on the molded article. The finishing operation is done by buffing with abrasive belts particularly adaptable for medium and larger molded items. One of the recommended cloths for finishing has a silicon carbide abrasive grain bonded by synthetic resin. These abrasive belts are available with grits of No. 24 to 600 mesh size. Grades ranging from 220 to 230 mesh have been found most useful for rough-finishing plastics and for the removal of sprue projections and heavy flash lines. Belts may be operated dry. Belt speeds should range from 2,000 to 3,000 ft. per min. When irregular surfaces are to be finished, it will be found that thin and narrow belts give best results.

Often, careful design study by the engineer will help to eliminate many subsequent machining operations. It will be found, however, that there are instances where machining is necessary, such as the drilling of small holes, particularly those at an angle which does not permit coring in the mold. Also, where dimensional accuracy is essential and low tolerances are specified,

machining will be necessary. It is best to do as little machining as possible on molded plastics in order to avoid breaking through the molded resin surface. If the surface is broken, chemical, electrical, or mechanical properties may be impaired.

As disclosed in previous discussion, all plastics are poor conductors of heat. Therefore, heat generated by the friction of cutting tools has to be carried away in some manner, either by the tool, by air stream, or by coolant liquids. Most machining of plastics is done dry. Since some compounds of the thermo-setting plastics, such as the phenolics and ureas, frequently contain abrasive fillers, tools may be dulled easily. Under conditions of improper speeds and rates of feed, tools may even

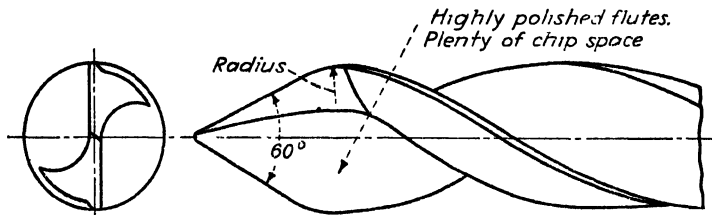

FIG. 47. - Drills usually have 60-90 deg included angle points and highly polished flutes.

burn. Another phenomenon that must be taken into account is the softening tendency of some plastics. In machining these, the frictional heat generated will heat up the plastic surface and cause it to become gummy. As a result, the tools build up a film of burned resin. In the case of high-speed drills this causes sticking and possible cracking and consequently inaccurate work. Stellite metal cutting tools are excellent for the machining of all types of plastics and will be found economical to use when long production runs are required.

As in all fine machine work, tools must be kept sharp. Lapping or honing the cutting edge is helpful in prolonging tool life and speeding the machining operations.

### DRILLING

For maximum efficiency in drilling holes up to  $\frac{1}{4}$  in. in diameter, it is recommended that drills especially designed for plastics, as shown in Fig. 47, be used. These drills are available in 60- to 90-deg. included-angle points with polished flutes, which are

wider than the standard machine drill and have a slow helix. Tests indicate that a 60-deg. included angle is desirable for sections up to  $\frac{3}{16}$  in. thick, and a 90-deg. point for thicker sections. A slow helix works best for through holes and a fast helix is best on blind holes. A 15-deg. lip clearance is provided by the tool.

Drills must be backed out and cleared frequently. This will free chips, especially in drilling deep blind holes. An air jet, directed into the hole and on the drill point, will increase the production of the standard drill twenty to thirty times before

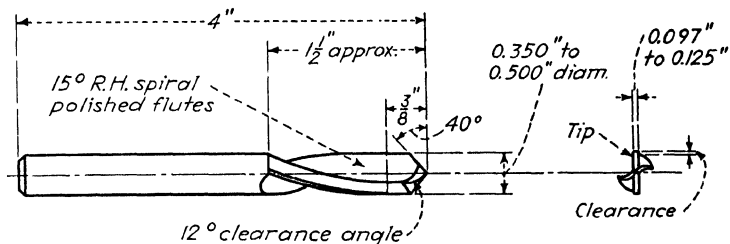

FIG. 48.—Drill designed especially for laminated plastics.

resharpening is required. Speeds of 100 to 300 ft. per min. are ordinarily used for drilling but for materials containing inert or abrasive fillers a slow speed of approximately 75 ft. per min. should be used.

When drilling laminated plastics, the lip should be ground thin with little rake. Plenty of clearance will prevent splitting and grabbing. The drill should not be forced, but should be kept sharp and light pressures used. Since the material shrinks, a slightly oversize drill is usually specified. For through holes, it is good practice to back the plastic with solid material or to use jig plates above and below. When drilling parallel to the laminations, a flat or "bottom" drill will usually avoid splitting.

When drilling cast phenolics, the drills sometimes cut about 0.003 in. undersize. Speed should be as high as possible without burning, and the tool should be backed out often. Negative rake helps to clear the drill. A drill ground as in Fig. 49 sometimes is used for drilling small holes, as in buttons. A half-round drill or boring tool, ground as in Fig. 50, is useful in drilling deep holes when the work is turned, as in a lathe.

For cellulose acetate, polystyrene, and acrylics, slow drill speed will minimize the tendency to heat up. The use of water as a

cooling medium will prevent the material from softening. Soap can be used as a lubricant for holes over  $\frac{1}{8}$  in. in diameter.

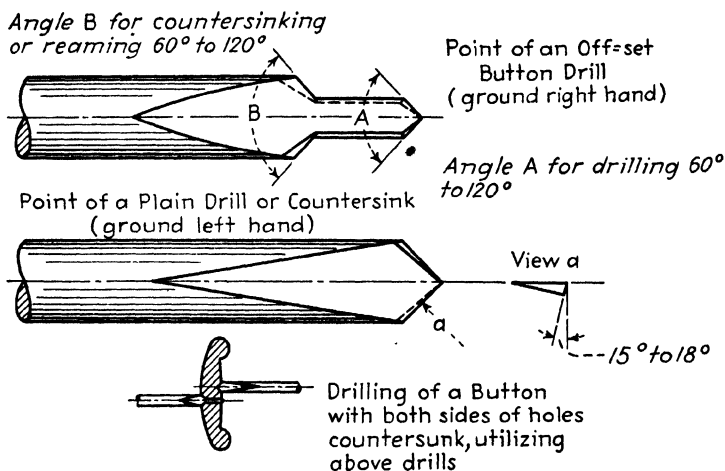

FIG. 49.—Drills used for small holes. Drills and countersinks are often used in pairs as shown.

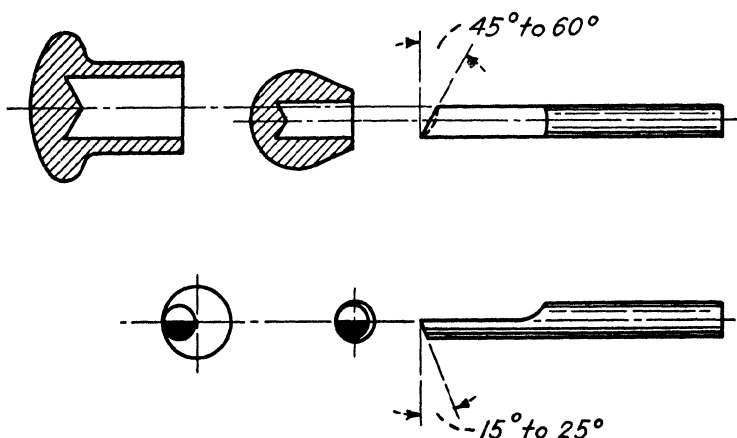

FIG. 50.—Half-round drill for deep holes in cast phenolics. Sketches at left show maximum and minimum diameters which can be bored in one operation.

Drills should be backed out frequently to clear chips. Light feeds will avoid strain and limit the consequent tendency of the material to chip or develop strain cracks after being worked.

Highly polished or chromium-plated drills prevent subsequent cracking or crazing of the piece.

Parts molded from vinyl plastics can be drilled in much the same manner as other synthetic materials. Standard drills and the usual feeds are used. For deep holes—those whose depths exceed twice the drill diameter—drills with extra large flutes should be used.

For drilling small holes in styrene or vinyl plastics, speeds of 4,000 to 6,000 r.p.m. are recommended. When the feed is kept as high as practical, the drilling time will be minimized. The reason for this is that the shorter the drilling time, the less the tendency for the bit to raise burrs around the edge of the hole. When the hole is being drilled properly and the operation is most efficient, the chip will emerge in a tight spiral similar to that produced while drilling mild steel. It should be noted, however, that this type of chip is not always produced. The chips are smaller if greater amounts of filler are present in the resin.

In the design of jigs for drilling, close-fitting drill bushings should be avoided. Close-fitting bushings may increase the friction on the drill and may also increase the tendency of the chips to plug up the drill flutes. If the operation is such that a drill bushing is absolutely essential, a floating leaf or template should be employed. When a template is used, the hole should be spotted with the template in place, using the drill size corresponding to the final hole size, then the template should be removed and the hole completed. Pilot holes should be avoided, except in special instances when the hole is to be reamed or counterbored. High-speed steel drills having polished flutes are generally recommended. The use of soapy water or water as a coolant will also facilitate the drilling operation.

#### REAMING

It is not common practice to ream molded plastics. Reaming is used primarily to remove light fins or flash in holes.

Where it is necessary to offset tapered holes, good results can be obtained if an expansion reamer is used. In conjunction with a self-centering floating holder, a fast-feed and slow-speed reamer—one not over 50 to 100 r.p.m.—should be used. On thin sections not over  $\frac{1}{8}$  in. thick, holes should be drilled within

0.001 in. size. A hardened and polished rod can then be used to burnish the hole to the desired dimension.

### THREADING AND TAPPING

High-speed nitrided and chromium-plated taps are best for the threading of small tap sizes. Speeds used range from 40 to 54 ft. per min. Tools have three flutes rather than the four commonly used in machine work. A negative rake of about 5 deg. on the front face of the land will in some measure help avoid binding of the tap in the holes when backing out. Small holes can be tapped dry. Water is a better tapping medium than lard, oil, or kerosene. Machine taps 0.002 to 0.005 in. oversize are recommended; these give 75 per cent of full thread to prevent the tap from breaking. A slight chamfer or countersink will minimize uplifting of material around the edge of the hole. Holes larger than  $\frac{1}{4}$  in. in diameter should be molded in rather than threaded or tapped later, except where very thin sections are involved.

Standard machine and pipe-tapping and -threading dies can be used satisfactorily on parts molded of vinyl plastics. The traverse should be single and uniformly continuous. Speed, which should be moderate to slow, is limited only by the rate of heat development. On lathe operations, the threading or chasing tool should be relieved considerably in order to reduce side friction. Any form of thread can be used, but the American National Standard for machine screws is most satisfactory.

Threaded inserts molded in the part will obviate the need for drilling and tapping small holes in molded pieces. On side or oblique holes in molded plastic housings it is desirable to use inserts that can be drilled and threaded after molding. This is necessary because of flash that may enter the threaded holes because of their positions in the mold cavity. Another problem that may arise is that of reshaping or retapping of threaded holes in brass inserts. This may also be necessary with holes already threaded in molded parts because of shrinkage variations of the finished molded dimension.

### LATHE OPERATIONS

In turning, facing, and boring operations on phenolic molded parts, tools having less clearance and more rake than those used

for steel or other metals are recommended. Cutting speeds are 200 to 600 ft. per min. for high-speed steel tools and 500 to 1,500 ft. per min. for Stellite metal-cutting tools.

In the turning of acetate and polystyrene molded parts, tools should have 0 rake and plenty of clearance set at an angle of 60 deg. to the spindle. Cuts should be made at a surface speed of about 65 ft. per min. and a feed of 0.010 in. per revolution. A smooth surface is obtained with a 0.020 in. depth of cut.

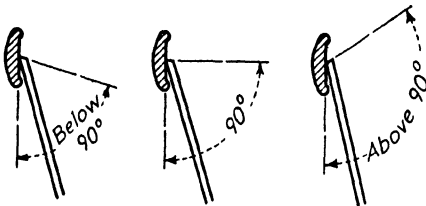

FIG. 51.—Cast phenolics can be faced at speeds ranging from 450 to 6,000 r.p.m. Best results are obtained with facing tool ground as in center sketch.

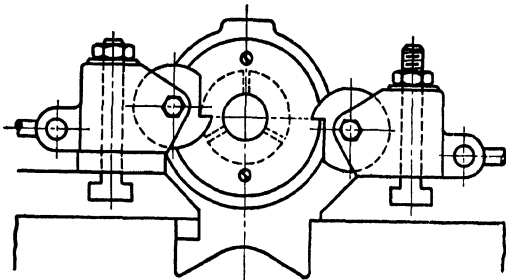

FIG. 52.—Formed circular cutters and circular cutoff tools are used on rod machines.

In turning cast phenolics, tools commonly are given 0 or slightly negative back rake and 15- to 18-deg. clearance. Tools must be sharp, and best results are secured when the chips are ribbonlike. For facing cast phenolics, work speeds range from 450 to 6,000 r.p.m. Facing tools sometimes are set slightly above center.

Too pointed an edge on facing tools tends to create chatter. Best results are secured with the tool ground as in the center view of Fig. 51. On rod machines, formed circular cutters and cutoff tools can be used to advantage, as in Fig. 52, or cutoff can be done with a saw.

Turning of acrylic plastics is done with tools having 0 rake and plenty of clearance, set at an angle of 60 deg. to the spindle. Cuts should be made at a surface speed of about 65 ft. per min. and a feed of 0.010 in. per revolution. A smooth surface is obtained with a 0.020 in. depth of cut.



FIG. 53.—Drilling a molded-laminated tube on a multiple drill, eight holes at a time.

For parts molded of vinyl plastics, simple turning, facing, boring, and chasing operations are performed satisfactorily with most ordinary metal-cutting tools provided that their front and side clearances are increased by about 50 per cent over the clearances used to machine steel. The added clearance reduces the rate of heat formation and produces good surface finishes and free-flowing chips. An increase in rake angle, made by hollow-grinding the top cutting face, offers some advantages in directing the chip away from the work. However, the accompanying reduction of cutting angle results in a greater tool wear.

With surface speeds between 250 and 300 ft. per min., depths of cut can be as high as  $\frac{1}{4}$  in., and rates of feed up to 12 in. per min. are possible. Higher speeds and feeds can of course be used with lighter cuts.

Cutting-off tools should also be ground with increased front and side clearances. In using them, the surface speed should be reduced to approximately one-half that used while turning. Slower speeds tend to roughen the cut surfaces, whereas faster speeds may cause overheating of the material.

For screw machine operations on laminated tubes it is better to specify a smaller inside diameter than required for finished size, or to use a laminated rod and drill it to size. Cutting feeds recommended are 0.007 to 0.015 in. per revolution for drilling; 0.010 to 0.015 in. per revolution for turning; 0.002 to 0.005 in. per revolution for cutoff; and 0.002 to 0.003 in. per revolution for forming.

The following spindle speeds are recommended for hand screw machines: 1 in. diameter and over, 800 to 1,000 r.p.m.; under 1 in. diameter, 1,500 to 200 r.p.m.;  $\frac{7}{16}$  to  $\frac{5}{8}$  in. diameter, 3,600 r.p.m.;  $\frac{1}{8}$  in. diameter and under, 5,000 r.p.m. Flooding with lard oil and kerosene tends to increase production and to prolong tool life.

### MILLING OPERATIONS

Where milling of molded parts is required, milling speeds and feeds in the range used for brass are recommended. Speeds are 400 ft. per min. with carbon steel cutters and 1,200 to 1,600 ft. per min. with carbide cutters. Single- and double-bladed fly cutters are sometimes used at high speed with fine cuts. Where little material has to be removed, a high-speed woodworking shaper with a carbide-tipped tool can be used to advantage.

The same general rules that apply to turning, facing, and boring operations also hold for milling parts molded from vinyl plastics. Standard cutters can be used, but higher speeds are feasible if extra clearances are ground on the cutter blades. Here again, it may be necessary to use an air blast to assure proper chip removal from the milling cutter. Wherever possible it is recommended that spiral milling cutters be used, and that the number of teeth in the cutter head be such that at least two of them are in contact with the work at all times. Plain cutters are to be

avoided, because of overheating caused by side friction. Milling cutters and blades should be given the same general care as turning, facing, and boring tools to assure that a minimum of surface friction is developed during machining.

Milling laminated plastics should never be done in a direction that will tend to separate the laminations. This is especially important in milling slots. In general, it is considered best to remove the full depth of material in a single cut.

In designing fixtures for milling parts, it is essential that the fixture grip the work in a manner that will not cause distortion of the work. Since parts molded from plastic materials are less rigid than metals and thus more easily distorted, the stock should be well backed up during the milling operation and should be positioned so that the pressure of the milling cutter is against the backing. When possible, cutters should be operated so that the chips are discharged from the leading edge of the cutter in contact with the work. To use a cutter in this manner implies that the machine is in good mechanical condition. Considerably less friction is developed if the cutter takes the heavy part of the chip first, as in climb milling.

#### CUTTING GEARS

In cutting laminated blanks, the feed should be the maximum that is possible without showing marks on the teeth. A coarse feed tends to reduce wear on the cutter edges. In hobbing, it is not necessary to make roughing and finishing cuts, as a single cut to the required depth is all that is required. Hobs of 3 to 4 in. pitch diameter may be run at 140 to 210 r.p.m. with feeds of 0.040 to 0.080 in. On shapers, gears are cut at 100 to 130 strokes per min. with a fairly fine feed, unless both roughing and finishing cuts are taken. In the latter case, 0.010 in. of stock for finishing may be removed at any desired speed or feed. In all gear cutting, the laminated stock should be backed up with wood or cast iron where the cutter breaks through the surface to avoid fraying or rough edges.

#### SAWING OPERATIONS

The sawing of molded phenolic parts is done chiefly on circular and bandsaws; bandsaws are recommended at times for straight cutting because they run cooler than circular saws.

Bandsaw manufacturers advocate saw teeth set to clear, some advocating one-half the thickness of the blade on each side so that saws give a width of cut double their thickness. Narrower saws and more set are needed for cutting curves than for straight cuts. Bandsaws just soft enough to permit filing are recommended, but they must be kept sharp. Dull saws cause chipping and might result in saw breakage. Sawing is usually done dry, but some recommend water for cooling. Saw teeth should have little set, and 8 to 9 teeth per inch—and should run at 1,800 to 2,500 ft. per min. See Table 12, page 85.

Sawing of cold-set polystyrene or cellulose acetate can be done with circular saws having 9 to 12 teeth per inch for thin sheets and 6 teeth per inch for thicknesses over  $\frac{1}{4}$  in. Saws 6 to 9 in. in diameter are run at speeds of 3,000 to 3,600 r.p.m. They should be hollow-ground and are usually  $\frac{1}{32}$  to  $\frac{1}{16}$  in. thick. A water spray gives a cleaner cut. One large saw manufacturer recommends that pieces be cut with a stream of water running in the kerf while the saw is cutting. This applies to both circular and bandsaws; otherwise, the thermoplastic materials will fuse. The circular saws recommended are 14 in., 12 and 9 gauge, 130 teeth, 10-deg. rake to be operated at 3,000 r.p.m. They are made of a special alloy steel stock.

For bandsawing, manufacturers suggest a bandsaw that is 19 to 20 gauge, having 20 points to the inch, and hardened and tempered. It should be operated at 4,000 to 4,500 ft. per min.

The most satisfactory method of sawing parts molded of vinyl plastics is with an underwater saw. When sawing unfilled resin, equipment should be fitted with hardened steel saws. The surface speed recommended is 3,500 to 4,000 ft. per min. (1,200 r.p.m. for a 12-in. saw) and the saw should carry 10 to 14 teeth per inch. The teeth should have no set. An average speed of travel through the stock is approximately 3 to 4 in. per min. It is possible, in some cases, to use speeds up to 12 in. per min. The finish of the sawed surface and the possibility of the stock's chipping at the leaving edge are affected by the rate of travel of the saw through the stock, the sharpness of the saw, and whether the stock being sawed is a solid piece or several smaller ones clamped together.

Although filled resin compounds can be satisfactorily sawed with an underwater saw in a manner similar to sawing the unfilled

compounds, the effective life of the saw is materially reduced by the filler. Fine-abrasive saws are preferable to metal saws. The abrasive saws will produce an equally good finish on the sawed surface at a considerable increase in saw life. Rubber-bonded cutoff wheels are not usable, but resin-bonded saws are perfectly satisfactory. Notching the saw helps to promote self-cleaning.

For laminated stock, circular saws that are hollow-ground and have no set generally are recommended where cuts must be smooth. Where rougher edges are permissible, saws with teeth set as for wood are satisfactory, the set making it unnecessary to hollow-grind. Decreased set as diameter increases is advocated by some; others recommend radial teeth with 0 rake. Table 12 gives the number of teeth and other specifications for sawing teeth of different thicknesses and tubes of different diameters. Chipping is caused by dull saws or by setting the saw too high or too low in reference to the table. Sawing usually is done dry, but some advocate water as a coolant. Smoother cuts sometimes are obtained by heating the material.

### PUNCHING

Punching, blanking, shearing, and shaving are done extensively on laminated plastics. Thickness of sheet, character of filler used, and temperature of the sheet are factors that determine the operations to be used. Some sheets can be punched cold, up to a certain thickness. Others require heating; usually the thickness that can be punched is greater when the sheet is hot. Heating can be done on hot plates or in ovens. The recommendations of the laminated supplier, both as to temperature and length of heating, should be followed. Some makes can be heated to as much as 280 deg. F. without injury and others only to 250 deg. F. Too high a temperature may affect the finish of the sheet and too long a heating may make it brittle. Punching should be done within 2 min. or less after heating.

Laminated materials yield somewhat when punched; as a result, the hole produced is slightly smaller than the punch. Allowance of about 3 per cent of the thickness punched must be made for this in punching as well as in blanking. A very close fit between punch and die, approaching a sliding fit for cold work, is required. Stripper plates should fit the punch closely to

prevent lifting at the edge of the hole as the punch is withdrawn. Progressive dies are satisfactory, but best results are secured with compound dies that place a spring load on the stripper. Blanking punches should be from 0.0001 to 0.008 in. smaller than the size of blank required. Press speeds are about 150 strokes per minute.

Punched blanks often have rough edges. This can be remedied by shaving in a hollow die, with a 45-deg. cutting edge, which

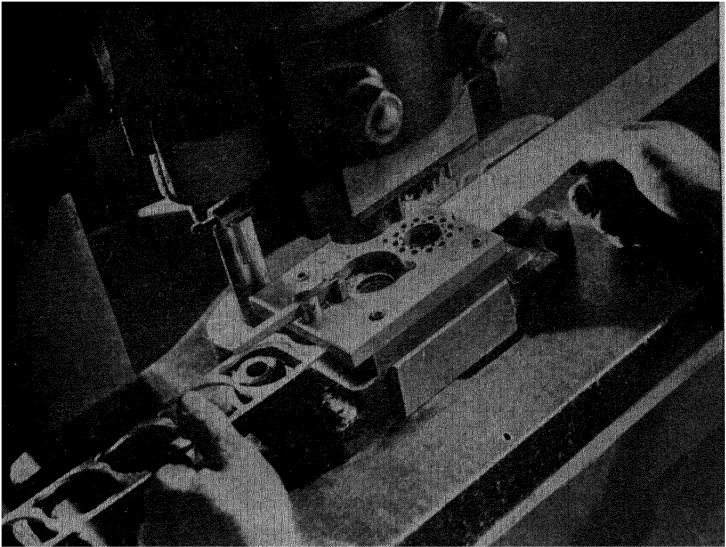

FIG. 54.—Punching special laminated stock used in radio insulation equipment.

must be sharp, using a brass or soft steel plunger. Shaving is done hot as a rule, but can be done cold on some materials up to about  $\frac{1}{8}$  in. thickness.

Cellulose acetate sheets can be punched and blanked with sharp-edged tools. To obtain smooth edges the sheet is warmed to about 125 deg. F., not enough to affect its polish. As the material is compressed by the cutting action one edge is concave and the other convex. This is hardly noticeable on thin sheets. Acrylics are blanked similarly with sharp-edged punches, but heating to 180 deg. F. is recommended for this type of material.

### EMBOSSING

Embossing, as in stamping or pressing letters, often is done in branding parts of plastic materials. Heated brass dies are used. The stock also is heated in some cases. Letters are often wiped in after embossing but can be made to stand out readily by covering the area to be marked with metal leaf before embossing, the pressure causing the leaf to cling in the recesses where the pressure is applied. Kick presses often are used.

Cast phenolic blanks, previously heated until soft, are often pressed in steel dies to form a design on one surface. This sometimes involves a fairly deep impression requiring considerable flow of material and may include punching of holes, as in buttons.

### POLISHING

Ashing, polishing, and buffing are done on nearly all types of plastics either to improve the finish or to remove sanding or tool marks left by preceding operations. Ashing is done with wet pumice; polishing with special compounds containing wax and sometimes a fine abrasive.

For larger pieces and some small parts requiring an extra fine surface finish, hand polishing or wheel buffing is necessary. The correct speed of lathes for phenolics and ureas using a 10 to 12 in. diameter wheel 4 to 5 in. wide is approximately 2,500 r.p.m. A speed of approximately 1,500 r.p.m. is used for styrenes and acetate materials. It is desirable to work with manufacturers of polishing supplies, as a certain amount of experiment (depending upon the material used and the design of the part) is necessary to determine optimum speeds for different compositions and different wheel constructions.

Articles molded from vinyl plastics can be buffed and polished with fabric wheels of the standard types. Precaution must be taken that only light pressures are used on the work. If the pressure is too great, sufficient heat may be generated to soften the stock and cause sticking to the fabric wheel. For general-purpose work, a muslin wheel with 1½-in. sewing and operating at 3,700 surface feet per minute may be used.

Where appreciable amounts of stock are to be removed during a polishing operation, particularly for the removal of wheel or machining marks from unfilled compounds, it is best to use a

cutting compound on a loose cotton wheel operating at approximately 6,100 ft. per min.

If the polishing operation can be performed wet, good results are obtained with a suspension of finely divided pumice in water and a loose muslin wheel operating at a peripheral speed of approximately 6,100 ft. per min. A constant stream of water and pumice fed to the wheel produces the best results. This operation is similar to the ashing commonly used in the polishing of all plastics and is the most effective way of obtaining a good surface luster on a production basis.

For laminated phenolics, grinding or sanding with No. 220 grit, cotton buffing wheels, with tripoli or other polishing compounds, will restore luster. Buffing without prior sanding can be done with tripoli to restore surfaces that have not been scratched too deeply in handling.

Tumbling in pumice and then in polishing compounds often is done on small plastic parts as a substitute for, or as a supplement to, wheel ashing and polishing. Tumbling also is done extensively to remove thin fins. As a rule, tumbling is done dry, but for cutting down with pumice and for subsequent polishing on acrylics, tumbling in wet pumice is advocated.

TABLE 12.—SAWS FOR LAMINATED PLASTICS\*

Bandsaws				
Type of work	Speed, ft. per min.	Width, in.	Thick-ness, in.	Teeth per in.
Scroll . . . . .	4,000-5,000	1/4-3/8	0.037	6
Circular disks:				
Up to 5 in. diam. . . . .	4,000-5,000	1/4-3/8	0.037	6
Over 5 in. diam. . . . .	4,000-5,000	1/2	0.037	5
Strips or blocks. . . . .	4,000-5,000	1 1/4-1 1/2	0.042	5
Circular Saws				
Material cut	Speed, ft. per min.	Diam-eter, in.	Thick-ness, in.	Teeth per in.
Sheet—1/16 in. thick . . . . .	2,500-3,000	10	1/16	6
1/8 in. thick . . . . .	2,500-3,000	14	3/32	4
1/4 in. and over . . . . .	2,500-3,000	14	1/8	4
Tubing: Under 1 in. o.d. . . . .	2,500-3,000	15	1/16	8
Over 1 in. o.d. . . . .	2,500-3,000	17	3/32	5

\* Courtesy of American Machinist

## CHAPTER VII

### PHENOLIC PLASTICS

Because of their versatility, relatively low cost, and wide availability, phenolics are perhaps the most widely used plastic materials for industrial applications. By the use of various

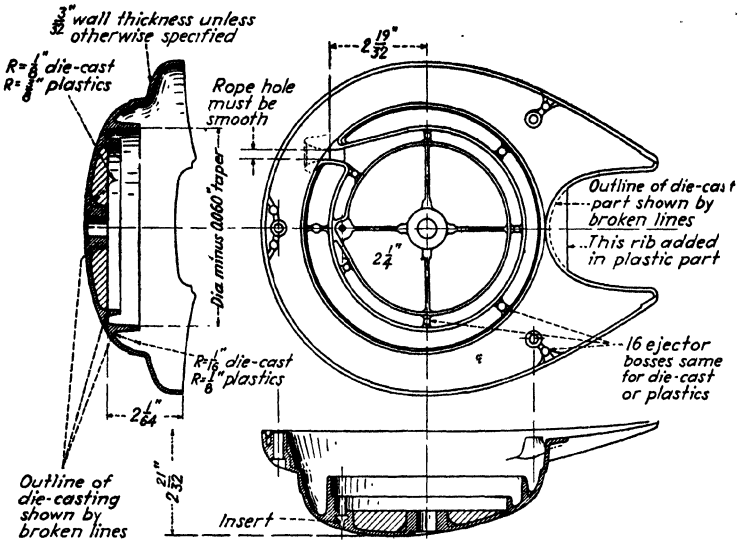

#### STARTER HOUSING

Previous: Die-cast Aluminum; Present: Molded Phenolic Resin

Design changes: Larger fillets; some ribs thickened; slightly greater mold relief tapers in plastic part; wall thickness remains same

*Note: Appearance is improved*

FIG. 55.—Recent redesign of starter housing from die-cast aluminum to molded phenolic.

fillers, phenolics can be had in many standard formulations to meet design requirements including high-impact strength, tensile strength, electrical insulating qualities, heat resistance, chemical resistance, moisture resistance, and wear resistance.

Phenolic molding compounds are made by reacting phenol (carbolic acid) with an aldehyde such as formaldehyde. The raw

materials, together with catalysts, are charged into steam-jacketed kettles and reacted under carefully controlled conditions of time and temperature. The product of this reaction is a viscous, sirupy liquid, which is poured from the kettle onto large cooling floors. Within a short time the liquid resin cools and hardens into a solid honey-colored mass. This base resin is ground and mixed with a lubricating agent and other materials to form a resin compound. To the resin compound are added

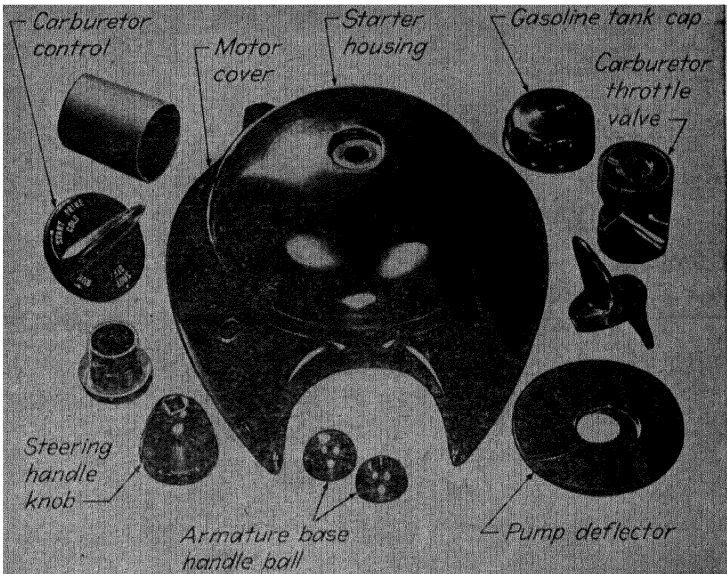

FIG. 56.—Starter housing and other parts of outboard motor redesigned for phenolic plastic.

dyes or pigments and fillers, such as wood flour, cotton flock, macerated fabric, mica, or asbestos. The resultant mixture is thoroughly kneaded on revolving heated rolls. Rolling blends the various ingredients and advances the reaction to the resin. The material comes off the heated rolls in rough sheets, which are cooled, ground, screened to specified particle size, and blended.

Phenolic materials have wide industrial applications because of the variety of formulations available. With the exception of possible surface tracking characteristics, the special compounds,

have acceptable electrical properties. Because of their high coefficient of expansion, phenolics shrink tightly around inserts, holding them firmly. Because of their relatively low cost, special characteristics, and adaptability to use of inserts, they are used for electrical switches, switch housings, and similar parts.

Fillers, as discussed in Chap. I, are employed to accentuate certain properties, such as better molding qualities, greater toughness and strength, heat resistance, and other characteristics.

Typical filler	Property obtained	Comment
Cotton.....	Medium impact strength	Good finish, good machinability
Rag.....	Higher impact strength	Fair finish, poor machinability, poor molding
Asbestos.....	Heat resistance Water resistance	Poor molding High sp. gr.
Mica.....	High electrical resistance	Poor machinability
Graphite.....	Acid resistance, lubricating qualities	Poor heat conductivity

The phenol formaldehyde materials may be grouped into four general classes, according to their outstanding characteristics: general-purpose, shock-resistant, heat-resistant, and special.

#### GENERAL-PURPOSE PHENOLICS

This material is cellulose filled and is widely used industrially for ordinary electrical and mechanical applications. These standard materials are successfully applied as automotive insulation and as decorative parts, such as switch plates, sockets, push plates, and door knobs. By far the majority of molded phenolic parts fall within this general-purpose group. These parts include button materials, closure materials for bottle caps and collapsible tube caps, those which require materials especially suitable for molding around inserts; printing plate matrices, where free-flowing properties are desired; parts that are molded of speck-free materials that can be molded, ground, and repolished without showing specks on the surface.

All general-purpose phenolics with the exception of plastics sheet materials are readily preformed on automatic tableting machines, molded at a die temperature of 300 to 350 deg. F.



resistance to shock or impact as compared to general-purpose phenolics. The group of shock-resistant phenolic molding materials have A.S.T.M. impact strengths ranging from 0.20 to 2.7 ft.-lb. energy to break. Of course these fillers add to the bulk factor. Hence the designer of molded plastic parts should remember that the greater the shock resistance of the phenolic

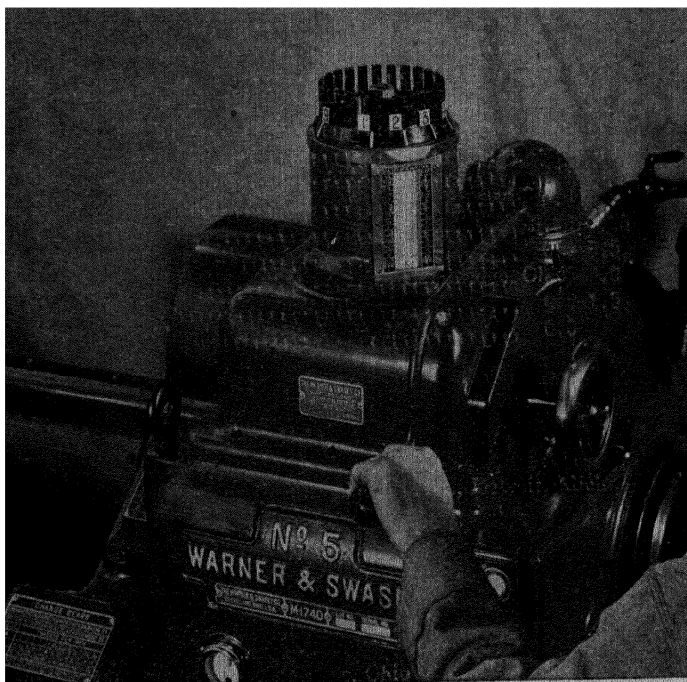

FIG. 57b.—Preselector drum on Warner and Swasey lathe is compression molded phenolic.

material, the more difficult the material will be to mold, because of the bulk factor and resultant poor flowing properties.

Uses of shock-resistant materials range from telephone handsets and tool housings to heavy-duty flashlight cases and oil-well drilling equipment.

#### HEAT-RESISTANT PHENOLICS

Mineral-filled heat-resistant phenolic materials are somewhat more difficult to process in the tableting and molding operations than the cellulose-filled materials, and parts molded from them

are less easily machined. This is caused by the presence of a mineral filler. These mineral-filled materials are employed when higher heat resistance and better water resistance are desired. They have a relatively low coefficient of heat expansion and relatively low shrinkage in the molding operation. These materials are available in a wide range of properties, each especially suited

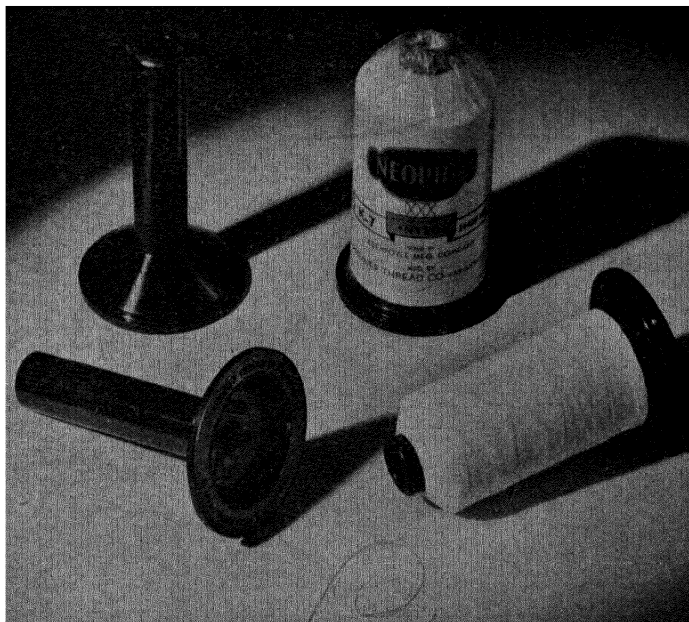

FIG. 58.—Textile spools of phenolic materials are light in weight, have smooth surface that prevents snagging of thread.

to a particular type of service. Heat resistance for these materials ranges from 390 to 475 deg. F. Typical applications include molded commutators, heat connectors, outdoor insulation, handles of cooking utensils, and such uses where the special property of heat resistance is required in the design.

#### SPECIAL PHENOLICS

A number of phenolic molding materials have been developed to meet special service requirements. These include high-frequency insulation material, mica-filled—generally referred to as

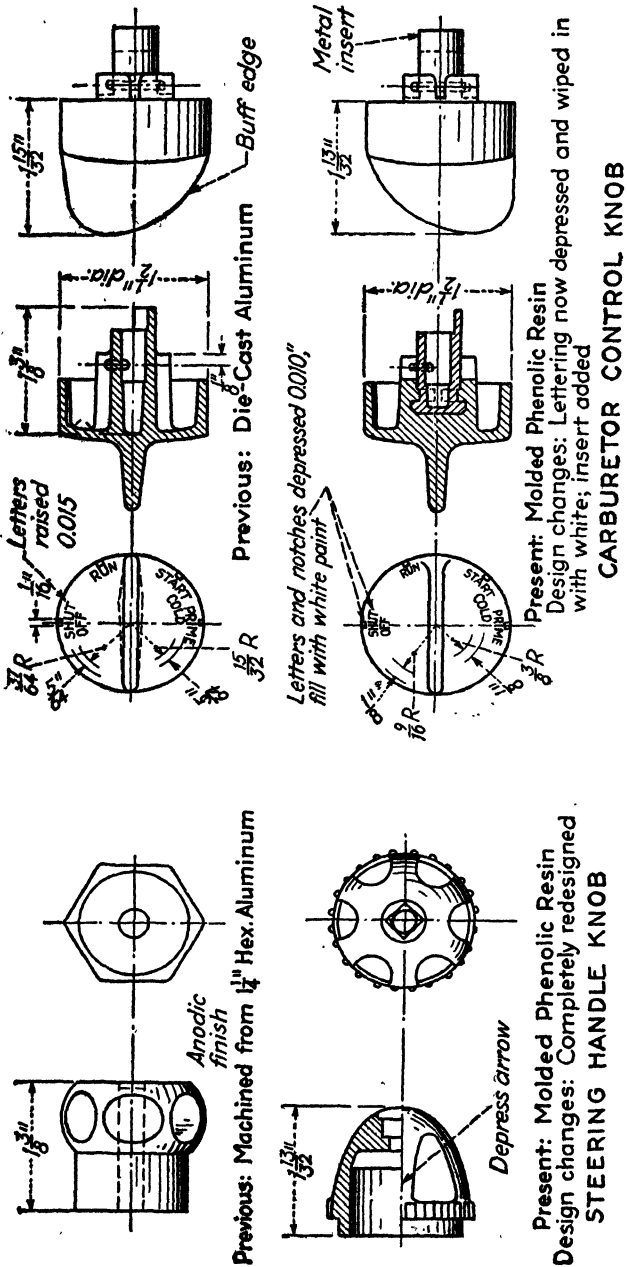

Fig. 59.—Typical design details of industrial parts molded of phenolic material, showing previous designs in metal.

a "low-loss" material. This is used for radio insulation and is generally recommended where low power factor, high dielectric strength, high resistivity, and low water absorption are desired.

Chemical-resistant phenolic materials, with special dried asbestos fillers, are excellent for use in contact with alcoholic liquids and water. Parts molded from this product have a very high finish. Water absorption after boiling is only about 0.47 per cent gain after 24 hr. boil. A special acid-resistant material has been developed for use in rayon and textile manufacture, where resistance to 10 per cent sulphuric acid is of prime importance. Alkali resistance is relatively good with some of the special phenolic materials, but no phenolic plastic compares with polystyrene in alkali resistance.

#### TRANSPARENT PHENOLIC MOLDING MATERIALS

These materials have no filler and are noted for their hardness, heat resistance, dielectric strength, dimensional stability, water and chemical resistance, and lightness in weight. One type approaches glass in freedom from odor. Another has such a high index of refraction that it approaches that of the ruby. Colors include light transparent amber as a neutral color, ruby, and green. Mottled and cloudy effects and some opaque colors are also obtainable. Typical applications of these nonfilled phenolics include automotive tail-light lenses, elevator-signal indicators, traffic-light signals, instrument housings, transparent containers, furniture drawer pulls and buttons.

#### PHENOLIC RESIN MOLDING BLANKS

Phenolic materials are also available in the form of blanks, which can be used alone for complete moldings or for the reinforcing of molded parts at strategic points where shock resistance is important. Blanks are cut or punched from molding board, which is made by combining phenolic resin and rag fibers. Test specimens of molded resin blanks possess an impact strength (Izod) of 1.6 to 2.0 in the direction of the grain and 0.6 to 0.90 ft.-lb. per in. of notch across the grain.

#### LOW FRICTIONAL PHENOLIC MOLDING MATERIALS

These materials, containing graphite, have been developed for use as refrigerator and automobile door ferrules, furniture casters,

bearings, and other applications where a low coefficient of friction is required. They have better resistance to shock than the general-purpose phenolics. Graphite also imparts a degree of acid resistance to the compound, and the finished surface is good.

TABLE 13.—PHENOL FORMALDEHYDE PLASTICS

	Wood-flour filler	Mineral filler	Fabric filler
Specific gravity.....	1.25-1.52	1.59-2.09	1.37-1.40
Specific volume, cu. in. per lb.	22.2-18.2	16.4-13.3	20.2-19.8
Tensile strength, lb. per sq. in.	4,000-11,000	4,000-10,000	5,000-8,000
Compressive strength, lb. per sq. in.....	16,000-36,000	18,000-36,000	20,000-32,000
Flexural strength, lb. per sq. in.....	8,000-15,000	8,000-20,000	8,000-13,000
Impact strength, ft.-lb. per in. of notch $\frac{1}{2}$ by $\frac{1}{2}$ notched bar, Izod.....	0.15-0.25	0.13-0.72	0.8-4.8
Dielectric strength, short time, volts per mil, $\frac{1}{8}$ in. thickness.....	300-500	250-400	150-450
Dielectric constant:			
60 cycles.....	5-12	5-20	5-10
1,000 cycles.....	4-8	4-20	4-6
1,000,000 cycles.....	4-8	4-20	4-6
Power factor:			
60 cycles.....	0.04-0.30	0.10-0.30	0.08-0.30
1,000 cycles.....	0.04-0.15	0.10-0.15	0.08-0.20
1,000,000 cycles.....	0.04-0.1	0.01-0.1	0.04-0.10
Water absorption, per cent in 24 hr.....	0.2-0.6	0.01-0.3	0.5-2.5

### PHENOLIC RESIN COATINGS

Resinous coatings when baked are phenol formaldehyde reaction plastic products of the thermosetting type. Because of their corrosion-preventive properties they are used as coatings on steel or other materials. Thus it is possible to replace many of the critical alloy materials in the corrosion-proof groups. In the viscous liquid condition as applied to the surface to be protected against corrosion, these coatings are solutions of phenolic resinoids. Application of heat causes the coating to harden by polymerization. When partly baked the coating is an insoluble elastic

semisolid. In this state another layer of liquid coating can be applied, after which another partial baking will fuse the layers together. After a thorough baking the resulting coating is a hard, tough, permanently infusible and insoluble solid.

#### METHODS OF APPLYING COATING

Heat should not be applied during the coating operation. The method of applying coating will depend on factors such as quantity in production, size and shape of parts, thickness of coat, or extent of impregnation desired. Dipping may be done by hand or by mechanical device. Parts that have no reentrant cavities or pockets that could entrap air can be dipped by machine. Spraying may be employed on parts that are too large to handle economically in a dip tank. Brushing should be used on pieces that have large flat surfaces. When brushing, the coating should be applied rapidly, otherwise it may drag or become tacky. Coats should be drawn out well, with special attention to working the coating into all seams and crevices and also to covering edges.

#### PREPARATION OF SURFACE

The surface should be dry and free from grease, rust, and scale. Sandblasting or washing with grease remover is recommended. Rough or sharp edges should be smoothed or rounded off in order to secure good coverage at these areas. After parts are dipped, sprayed, or brushed, they are placed in a drier oven to dispel solvents in the viscous coating. The drying operation pre-bakes the coating and partly polymerizes the resin. This initial baking requires about 15 min. at a temperature of 176 deg. F. for small work.

To polymerize the resinoid material completely in the coating, the final coat is baked at higher temperatures. Satisfactory results are not likely to be obtained below 230 deg. F. For small work that can be placed in an oven, baking at 248 deg. F. for 3 hr., or 300 deg. F. for 1 hr., is usually required. Structures that are too large to place in an oven are baked by processes that employ portable equipment that can be moved to the job; this apparatus when set up provides a circulating blast of hot air to bake the coating. When the coating is to be applied to apparatus that is ordinarily operated at high temperatures, it is frequently

possible to secure the baking effect by an application of heat in the vessel itself.

#### PROPERTIES OF BAKED COATING

1. Hard, continuous, uniform composition.
2. Does not melt at any temperature.
3. Will not char at temperatures below 300 deg. F.
4. Unaffected by extremes of climate, temperature, or humidity.
5. Relatively unaffected by water, alcohol, acetone, benzene, common solvents, oils, greases, organic acids, dilute mineral acids, and common soap lubricants.
6. High mechanical bonding strength.
7. Good electrical insulator.

TABLE 14.—ACCELERATED TESTS ON PHENOL COATINGS

Corrosive agent	Concentration, per cent	Time, days	Temperature, deg. F.	Effect
Acetic acid.....	5	1	240	Breakdown of coating
Carbon tetrachloride..	100	8	170	None
Chromium plating bath	...	2	180	Breakdown of coating
Hydrochloric acid.....	10	8	214	None
Lactic acid.....	25	15	220	Slight color change
Sodium cyanide.....	10	1	240	Breakdown of coating
Sodium formate.....	10	12	220	Change in color
Stearic acid.....	100	11	183	None
Sulphuric acid.....	10	22	214	None
Sulphuric acid.....	10	4	227	None
Sulphurous acid.....	10	30	100	Breakdown of coating
White distilled vinegar	...	3	214	Breakdown of coating
Witch hazel.....	100	5	206	None

#### PHENOL FURFURAL RESINS

Phenols, as mentioned previously, are obtained from coal by-products. When these resins are combined with furfural obtained from oat hulls and other waste farm products, a plastic material is obtained that has some interesting characteristics.

Phenol furfural resins flow readily under poor molding conditions. This makes them suitable for difficult and complicated moldings requiring "long flow." Another outstanding property of these resins is that they maintain their flow characteristics

over considerable periods of time at temperatures just above plasticity temperature. This makes them particularly suitable for injection molding by the transfer process. Although they flow readily, the resins cure rapidly at temperatures above 350 deg. F. This serves to maintain accuracy of dimension and positioning of inserts. As a further corollary, the resins "set up" to a sufficiently rigid condition to permit hot pulling from the mold. Thus the molding process can be speeded up and greater production obtained.

In addition to excellent moldability and good dimensional permanence, the more important properties of the phenol furfural resins include chemical inertness, high heat resistance, good electrical properties. The effect of aging is to improve dielectric and mechanical properties. These resins are used in molded distributor plates, automobile and truck brake linings, magnetos, thermostats, radio cabinets, precision instrument cases, aircraft pulleys, distributor heads, and complicated parts, such as magnetos. Other applications include chemical and acid-resistant coatings, abrasive grinding wheels, and communication systems.

TABLE 15.—PHENOL FURFURAL RESINS\*

	Wood-flour filled	Mineral filled	Fabric filled
Specific gravity.....	1.3-1.4	1.6-2.0	1.3-1.4
Specific volume, cu. in. per lb.	21.3-19.8	17.3-13.9	21.3-19.8
Tensile strength, lb. per sq. in.....	6,000-11,000	5,000-10,000	6,500-8,000
Compressive strength, lb. per sq. in.....	28,000-36,000	24,000-36,000	26,000-30,000
Flexural strength, lb. per sq. in.....	8,000-15,000	8,000-20,000	10,000-13,000
Impact strength, ft.-lb. per in. of notch ½ by ½ notched bar, Izod.....	0.30-0.56	0.32-0.74	1.20-4.60
Heat distortion point, deg. F.	270-290	275-295	
Dielectric strength, short time, volts per mil, ½ in. thickness.....	400-600	200-500	200-500
Dielectric constant, 1,000,000 cycles.....	6-7.5	5-18	5-7.5
Power factor, 1,000,000 cycles	0.04-0.1	0.04-0.1	0.04-0.1
Water absorption, per cent in 24 hr.....	0.2-0.6	0.01-0.15	0.8-1.4

\* Courtesy of Durite Plastics, Inc.

## CHAPTER VIII

### CAST PHENOLICS

Unlike other plastic materials, cast phenolic resins are not supplied in powder form and cannot be injection- or compression-molded to final form. Phenol and formaldehyde combined with a catalyst are processed in huge kettles under a vacuum. The basic ingredients in liquid form are cooked, starting a process of polymerization which continues throughout successive production steps to the finished casting.

In the next production step, the mixture is again subjected to a vacuum, and the water, which is a product of the phenol formaldehyde reaction, is drawn off. After the proper dyes are added to give color, the liquids are drawn from the bottom of the kettles and poured into lead molds. The molds are then placed in vulcanizing or curing ovens where polymerization continues until fully cured castings having a Rockwell hardness of approximately plus B50 to 100 are produced.

The castings are removed from the molds by air hammers. The temperature of the ovens is maintained at 80 deg. C. throughout the polymerization, and no pressure is involved in the molding at any point. However, the casting process is particularly interesting to the designer inasmuch as it sets the limitations within which he must work and affects production cost.

Since no filler is used in the production of cast phenolic resins, they have great depth of color and richness of luster. As a further corollary, cast resins have good machining qualities that permit considerable flexibility of design and low initial setup cost.

#### METHODS OF FABRICATION

When casting is being compared with compression and injection molding, the following factors are important. Initial tool costs on cast phenolic are considerably lower than on molding. Thus cast phenolic will often be economical on runs that, compared to the average compression mold run, are relatively short—several

thousand or less. This factor is important in the design of large parts, such as pilasters, since as the size of a given part goes up, the cost of compression molds increases almost geometrically. On the other hand, cast phenolic parts may require more fabrication than molded parts, which generally require only removal of flash and a light buffing. A point in favor of cast phenolic is that standard forms are available for many parts, and thus initial tool cost can be eliminated.

Three types of molds are employed in the production of phenol formaldehyde cast resin material: straight-draw molds, split molds, cored molds.

Approximately 90 per cent of the phenolic castings produced are cured in straight-draw molds. In this method, a steel dipping arbor or mandrel is machined to the specifications of the finished casting and attached to a plate and handle. The mandrel is then dipped into a pot of molten lead, which flows up the sides of the steel and cools on removal from the pot. When stripped from the arbor, the open lead mold is ready for use. It is obvious that no undercuts can be designed into a casting of this type. Flutes, scallops, beads, and other design accessories may be incorporated in the castings, but they must run in the direction in which the castings are removed from the mold. Tubes, boxes, round rods, pilasters, and other large parts having profile shapes of all types may be produced in this manner. A taper of approximately 0.0015 in. per in. is necessary in order to break the vacuum, reduce friction, and permit the casting to be removed from the mold.

Because of this taper and because the castings are forcibly removed from the molds, there are certain minimum requirements for wall thickness. For large radio cabinets, box castings, long tubes, plate castings, and similar items, the walls of the castings must be  $\frac{3}{16}$  in. thick. For small tubes, small boxes, and other articles that can readily be removed from the molds, a  $\frac{5}{32}$ -in. wall is required. In the case of small castings, such as hollow bottle closures,  $\frac{1}{8}$ -in. walls will suffice. The taper in all cases is plus from these dimensions.

Certain factors should be borne in mind when designing cast phenolic parts. Where large flat surfaces are required, it is desirable to use mottled or marblelike colors *since minor imperfection in color will not usually be discernible* and rejects will therefore be reduced. Corners or edges should be given a slight

radius, not only to facilitate the casting operation, but as a help in reducing machining time after the part has been withdrawn from the mold.

To obtain half-spherical hollow castings, pilasters with compound curves, and large castings with decorative faces, cored molds are used. In this case a dipping arbor is made to the outside specifications of the finished piece; if a half-spherical hollow casting is specified, the arbor and consequently the lead molds will have the dimensions of the periphery of the sphere. Into this mold and properly centered  $\frac{3}{16}$  to  $\frac{1}{4}$  in. away from the lead, is placed a metal core, the outside dimensions of which are identical with the inside dimensions required of the hollow sphere. Between the core and the lead mold liquid resin is poured for curing in the ovens. When the material reaches the proper hardness, the core is removed and the casting drawn from the lead mold.

Although this production method permits a considerable latitude in designing, it is not recommended for units smaller than 4 by 4 by 4 in. The amount of handling per casting remains the same and the number of cores required remains the same, but the material over which these costs are amortized drops to a quantity so low that the price per pound is prohibitive. No production quantity limitations are placed on this type of molding, and the cores may be used for an indefinitely large production. No taper is required on castings made in this manner, and the walls can be of any thickness above  $\frac{3}{16}$  in.

An important feature in this connection is that walls can be made as thick as is consistent with the structural requirements of the product without fear of undercuring, defective castings, or distortion. However, there are virtually no limits to how large a casting may be; units 20 in. square and 12 in. deep are now included in regular production. Pilasters as long as 26 in. and having a periphery of 18 in. are likewise standard production.

The shrinkage factor is particularly important in designing castings of large size since it amounts to approximately 1 per cent and can have a serious effect on the assembly unless the phenolic units are properly mounted and assembled.

Where extremely long pieces, such as pilasters, are involved, the castings in final assembly should be suspended and fastened at either the top or the bottom, riding in grooves along the sides

so that expansion and contraction with temperature changes and any shrinkage will not set up stresses that result in cracking.

It will be noted from the description of the cored molding process that it concerns open molds, *i.e.*, the material is poured into the openings between the core and the lead mold.

In split molding, the process involves two-piece molds closed at all points except for the gate into which the liquid resin is poured. Undercut designs may be incorporated into articles produced by the split-mold method so long as the undercuts are not more than two-directional. It must be possible on opening the mold to draw each half away from the casting without incorporating undercuts in the respective half.

In this case, die-casting machines are used for production of the lead molds, the machines making one-half of the mold at a time, each of which interlocks with the opposite half of the neighboring mold.

The successive sections are clamped together, liquid resin is poured into the gates, and the material is cured in the usual manner. Walls cannot be less than  $\frac{3}{16}$  in. thick. To produce the item economically there should not be more than 10 to the pound.

From the foregoing it will be seen that expensive tools are not necessary in the production of cast phenolic plastics. Dipping arbors vary from \$90 to \$375, depending on the size and intricacy of the design. Arbors and tools for producing cored castings vary in cost from \$275 to \$800, and tools for producing split-mold castings range between \$250 and \$550.

On these rough castings, varying amounts of fabrication are necessary. From the split-mold castings the gate and the fin must be removed. From the cored mold and straight-draw mold castings, the flash which varies from  $\frac{1}{8}$  to  $\frac{3}{16}$  in. at the open end of the mold must be machined off.

Because of the machining qualities of cast phenolics, these operations can be performed with a minimum amount of expense. The flash is removed either with a bandsaw, an abrasive cutoff wheel, or a dry or wet grinding disk, depending on the application for which the casting is intended. It is then drilled and tapped for assembly or drilled for stapling, then routed, beveled, shaped, polished, and otherwise handled much the same as wood or metal, using substantially the same tools and equipment. See

pages 71 to 85 for further discussion of the machining of cast phenolics.

TABLE 16.—PROPERTIES OF AVAILABLE CAST PHENOLICS

	General-purpose, opaque, and translucent	General-purpose, transparent	Special purpose, chemical-resistant	
			Transparent	Opaque
Specific gravity.....	1.30	1.30	1.27	1.70
Tensile strength, lb. per sq. in....	3,500-5,000	3,500-5,000	5,000-7,000	6,000-9,000
Flexural strength, lb. per sq. in....	7,000-9,000	3,000-7,000	9,000-14,000	10,500-12,000
Impact strength, energy to break in ft.-lb. $\frac{1}{2}$ -in. sq. rod, notched	0.15-0.20	0.175-0.225	0.15-0.20	0.19-0.24
Heat distortion, deg. C.....	40-45	40-45	55-65	75-76
Water absorption in 48 hr. per cent room temperature.....	0.5-2.0	0.015-0.60	0.4-0.6	0.4-0.6
Brinell hardness, 5-mm. ball.....	20-30	15-20	35-40	35-40
Dielectric strength, step—0.125 in. thick, volts per mil.....	200-250	175-200	275-300	120-142
Power factor, 60 cycles.....	0.25-0.35	0.25-0.50	0.10-0.15	0.07-0.074
Dielectric constant, 60 cycles.....	15-20	20-30	7-8	30-31
Loss factor, 60 cycles.....	2.5-8.0	10-16	0.70-1.0	2.07-2.20

*Water absorption* after 8 days' immersion: 0.0057-0.0081 gr. per sq. in. of surface.

*Water absorption* after 80 days' immersion: 0.0132-0.02 gr. per sq. in. of surface.

*Softening ranges:* 176 to 212 deg. F.

*Effect of dry heat:* withstands up to 160 deg. F. with slight hardening and shrinkage.

*Effect of moist heat:* withstands up to 160 deg. F. with slight hardening and shrinkage.

*Effect of aging* (indoors): slight increase in hardness, improves in electrical properties.

*Effect of aging* (outdoors in sunlight, one year): slight increase in hardness, yellowing and fading of nonfast colors. Mechanical and electrical properties not appreciably changed.

*Effect of water* (cold): none.

*Effect of water* (hot): withstands intermittent washing with hot water. Slight deterioration after 100 hr. complete immersion.

*Effect of strong acids:* slowly attacked.

*Effect of alkali* (weak): can be washed with soap and soap powders. Slowly softens when immersed in alkaline solutions, showing slight discoloration.

*Effect of alkalis* (strong): slowly attacked.

*Effect of alcohols:* insoluble, slight swelling in ethyl alcohol after long immersion.

*Effect of mineral, animal, or vegetable oils:* none.

*Effect of hot flames:* chars but does not support combustion.

*Solubility:* insoluble in water, organic solvents, and acids. Slightly soluble in alkalis.

*Tendency to cold flow:* none.

*Opacity range:* opaque to transparent, all colors.

*Colors:* innumerable.

*Forming qualities:* good.

*Machining qualities:* excellent.

*Light transmission* ( $\frac{1}{8}$  in.—40 watt source): 70 to 92 per cent.

*Ultraviolet transmission* (2,800-3,200Å.): 18.3 per cent.

*Index of refraction:* 1.46.

Several methods of fastening the castings are available. Liquid phenolic cements are used in some assemblies, but machine

screws, drive screws, and self-tapping screws can also be used. It is not recommended that phenolic castings or sheets be joined to material having a different coefficient of expansion and contraction. For example, a piece of phenolic sheet stock joined to plywood will crack should the plywood swell with the absorption of moisture.

Colors available vary from water clear to jet black, in a wide variety of stock shapes, including round, square, octagonal, and hexagonal rods, cylinders, sheets, and plates. Sheet material is available in any size up to 24 by 48 in. and in any thickness above  $\frac{1}{8}$  in. It can be obtained usually either polished or unpolished.

An important feature of cast phenolic plastics is translucency, characteristic of practically all colors except the dark browns, blues, and blacks. This characteristic is used to advantage in decorative pieces for fluorescent lighting fixtures, coin-operated phonographs, housings, and in interior lighting effects.

## CHAPTER IX

### UREA PLASTICS

Urea resins are produced by reacting urea with formaldehyde, continuing the process by means of appropriate chemical control until the desired degree of polymerization has taken place. Urea itself is synthesized from ammonia and carbon dioxide. The suitability of urea resins for various applications is closely dependent upon the type and extent of polymerization.

#### CHARACTERISTICS

Characteristics of urea formaldehyde resins are translucency, attractive depth of color, many colors available, and good electrical properties. These make urea plastics, although they cost nearly twice as much as black or brown phenolic molding compounds, the choice for a growing field of uses, principal among which are lighting fixtures, machine housings and products where appearance is a primary consideration, and many electrical parts. Urea resin adhesives also have many advantages over other glues, particularly for high-strength, water-resistant plywood. See Chap. XVII for further data on plywoods and adhesives.

Urea molded plastics are durable and mechanically strong. They are unaffected by water, oils, greases, and organic solvents. Ureas are thermosetting in nature and consequently do not deform when heated. However, they are subject to decomposition if heated to high temperatures. Nevertheless they may be used without restrictions at temperatures below 170 deg. F. and suffer no effects if intermittently exposed to higher temperatures (245 deg. F.). At temperatures above 170 deg. F. they gradually become brittle, more opaque, and lose color stability. In most cases where high temperatures are encountered, the molded article can be designed to overcome this defect.

Urea plastics may be varied in optical density from translucent naturals to opaque whites. Even these colors can be modified to yield pleasing daylight effects with little reduction in efficiency.

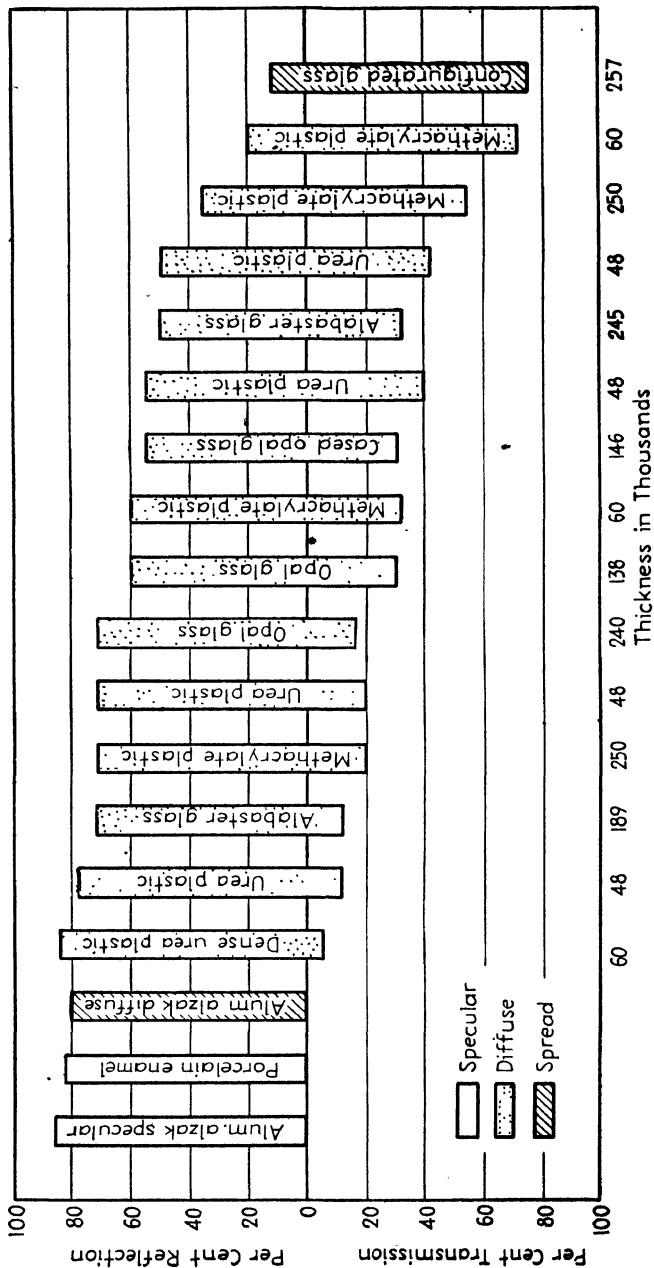

Fig. 60.—Comparison of optical properties of urea formaldehyde resins with those of other materials used in lighting reflectors.

Figure 60 indicates the comparison of the optical properties of urea plastics with other common luminaire materials.

Although urea plastics have long been known for their unlimited color range and durability, they are now recognized for their good electrical properties, particularly where resistance to arcing and tracking is important. These properties are indicated in Table 17. When arcing occurs over a urea resin surface, the heat decomposes the resin but does not create a carbonized track as it does with phenolic resins. Therefore, resistance to arcing remains nearly the same for urea but is reduced for phenolics by the track after the first arc flash.

Urea molded plastics are unaffected by light and are odorless, tasteless, and nontoxic. These several properties combined with those mentioned in the following tables make urea formaldehyde plastics suitable for buttons, instrument housings, business machine housings, lighting devices, closures, electrical items, tableware, kitchenware, and hardware.

Effect of moisture on urea molded parts is to cause slight swelling, which may cause cracks to appear at abrupt changes of section of improperly designed parts when the part is alternately subjected to extreme moisture and dryness. Laboratory tests often are made on a newly designed part and may indicate modifications in the design or molding process that are necessary to eliminate cracking caused by moisture.

Typical of applications involving continuous exposure to a high degree of radiated heat, is the use of plastic reflectors for modifying the light output of incandescent lamps. Curves are available showing safe operating positions of semiindirect reflectors. They are based on the known upper heat limitations of urea plastics and the heat radiation of various wattage lamps.

Urea plastics absorb little visible light and make highly efficient lighting reflectors. These may vary from 6 to 28 in. in diameter. The number of varieties commercially available is large. In every instance their efficiency is well above 80 per cent, an improvement over materials formerly used. Compared with glass, urea molded parts weigh only one-third to one-half as much, are scatterproof, and permit greater variations in design.

In addition to molding compounds, urea formaldehyde resins are available as waterproof adhesives. They can be applied to wood containing up to 15 per cent moisture and require no

TABLE 17.—PROPERTIES OF UREA MOLDING COMPOUNDS\*

Forms available.....	Fine powder, granules
Molding qualities.....	Excellent
Molding temperature.....	290-320 deg. F.
Molding pressure.....	1,500-6,000 lb. per sq. in.
Compression ratio.....	2.5-3.0
Mold shrinkage.....	0.006-0.011 in. per in.
Colors.....	Unlimited, from natural colorless to black
Specific gravity.....	1.45-1.50
Specific volume.....	19.1-18.5
Tensile strength.....	5,000-13,000 lb. per sq. in.
Modulus of elasticity, tension.....	1,550,000-1,650,000 lb. per sq. in.
Compression strength.....	24,000-35,000 lb. per sq. in.
Flexural strength.....	10,000-15,000 lb. per sq. in.
Impact strength, ft.-lb. per in. of notch	
½ by ½ bar .....	0.28-0.32
Hardness:	
Brinell (500 kg. -10 mm.).....	48-54
Rockwell.....	M110-M130
Scratch (Mohs' scale).....	3
Softening point.....	None
Cold flow.....	None
Upper critical temperature, continuous	180 deg. F.
Distortion.....	None below 180 deg. F.
Thermal conductivity, 0.0010 cal./	
(sec.) (sq. in.) (deg. C.) (cm.).....	7.0
Specific heat.....	0.4
Burning rate.....	Chars, does not support combustion
Dielectric strength, volts per mil, 60	
cycles A.S.T.M. D149-40T	
6 in. disk 0.050 in. thick	
Short-time test 1,000 volts per sec..	680-720
Dielectric constant:	
60 cycles.....	6.6-8.6
1,000,000 cycles.....	5.5-7.7
Power factor:	
60 cycles.....	0.03-0.05
1,000,000 cycles.....	0.03-0.029
Volume resistivity, ohm-cm.....	10 <sup>12</sup> -10 <sup>13</sup>
Tracking.....	None
Arc resistance†.....	Excellent; 196 sec. at 15th step

\* Courtesy of Plaskon Co., Inc.

† The arc-resistance test was made as follows:

Two electrodes with tungsten tips 0.06 in. in diameter pointed to a 60-deg. cone were held in a wood block with a gap of 0.32 in. between the points and at an angle of 90 deg. to each other. These electrodes were then set with the points resting on the upper surface of a specimen. Connection was then made to the high-tension side of a testing transformer.

special treatment after gluing. They have high strength, both in dry and wet bond. The urea glues have high resistance to cold water and warm water up to 180 deg. F. Cold-setting glues supplied in two parts and modified urea glues have good resistance to hot water above 180 deg. F. Resistance to mold and fungus is high, and exterior durability is good. Properties of the various types in common use are shown in Table 44.

Urea glue lines are practically colorless. In some industries where maximum physical properties are required and where a single failure to incorporate hardener would endanger reputation and life, such as in aircraft manufacture, the hardener is tinted with a dyestuff that enables visual inspection and supervision of the final assembly.

Special forms of urea resins include foamed urea resin, special dry-coating material, resin for laminated high-impact fabric, creaseproofing compound, fireproofing finishes, wet-strength paper resins, and resins for laminated paper containers.

---

The open-circuit potential was adjusted to approximately 8,000 volts, an arc was formed between the points, and the current was controlled by resistance in the low-tension side. The arc was applied in the following sequence until a conducting path had been formed in the sample:

- 1st min., 10 ma.,  $\frac{1}{4}$  sec. on,  $1\frac{3}{4}$  sec. off
- 2d min., 10 ma.,  $\frac{1}{4}$  sec. on,  $\frac{3}{4}$  sec. off
- 3d min., 10 ma.,  $\frac{1}{4}$  sec. on
- 4th min., 10 ma., continuous
- 5th min., 20 ma., continuous
- 6th min., 30 ma., continuous, increasing the current by 10 ma. each min.

The mechanical properties do not change perceptibly even at temperatures as low as  $-77$  and  $-186$  deg. C. Tests were conducted by soaking the test pieces in a mixture of carbon dioxide ice and ether for  $-77$  deg. C. and liquid nitrogen for  $-186$  deg. C. and testing immediately, the test equipment being at room temperature. The Charpy impact test was evaluated under these conditions.

## CHAPTER X

### ACRYLIC PLASTICS

Cast acrylic sheets are being used by the aircraft industry for transparent cockpit enclosures, blisters, and observation turrets. These sheets are used because they possess characteristics that are particularly vital in aircraft design: strength, light weight, and transparency. They are less than half as heavy as glass; they are much stronger; and they have better optical properties than most glasses. Sheets of this material can be cut with ordinary saws, machined and drilled with usual metalworking tools. They have the additional advantage of assembly by cementing.

Acrylic resins are derived by a complicated chemical synthesis from acrylic and methacrylic acids. The resins were first developed by Dr. Otto Rohm. They range in consistency from soft semitacky liquids to tough thermoplastic solids. No fillers are used with acrylics. Experiences with installation of transparent plastic sheet in aircraft have emphasized the importance of certain design fundamentals. Methods of installation have been devised to take advantage of the properties of this type of plastic to increase its usefulness in aeronautical design.

Acrylic sheets have been used to replace glass over the dials of gauges and other indicators where glass would be a hazard because of its fragility. If desired, the installation can be made waterproof by taking advantage of the thermoplastic characteristic of the sheet. The acrylic resin material softens when heated and can easily be formed to shape; when cooled, it will retain this shape until it is reheated. Then, because of its so-called "elastic memory," it will resume its flat sheet form. To make a tight, waterproof joint, therefore, the sheet is heated and formed to the shape of a dome, snapped into position in the mounting ring of the gauge, and heated again, upon which the sheet tends to flatten, forming a tight, waterproof joint. Waterproof acrylic resin cements may also be used for this purpose, alone or in combination with gaskets.

Because acrylic resins are thermoplastic, sheets can readily be made into curved inspection windows in all types of machinery. After being heated in an ordinary oven and then shaped over a wooden form, the sheet can be mounted securely and simply.

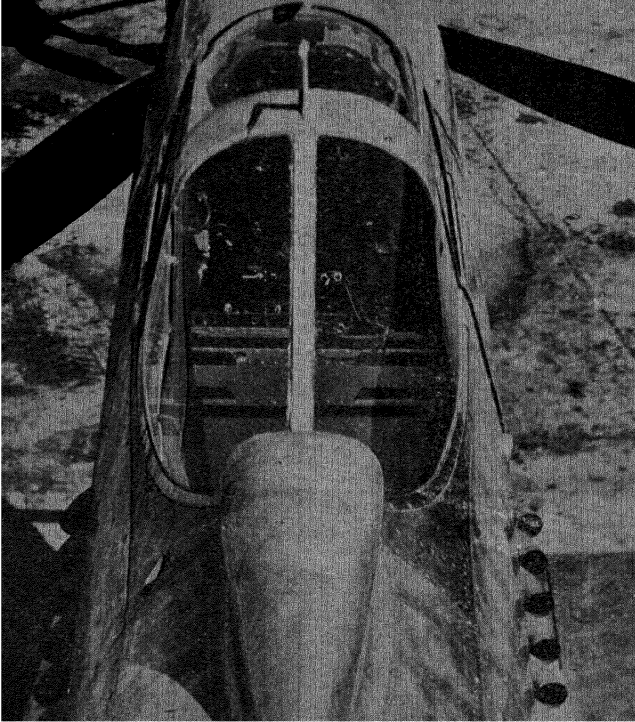

FIG. 61.—Typical acrylic plastic installation on Bell Aircraft. (Courtesy of Bell Aircraft Company.)

In industrial applications, the acrylics are useful because of their resistance to most chemicals, to weak alkalies, to non-oxidizing acids, to oils, to solutions of inorganic salts, and to almost any chemicals except organic solvents and lacquer thinners. Acrylic resin sheets often outlast glass many times over on grindstone guards and in applications where scratching is a serious factor. If the minor scratches eventually obscure vision through the sheet, they can be polished out on soft linen buffing wheels with fine polishing compounds.

When a large number of any one size and shape of gauge glass or inspection window is required, advantages can be obtained by molding the piece rather than fabricating it from sheet. For parts where molding is feasible, molding eliminates almost all the ordinary fabricating operations and can also eliminate costly assembly operations and complicated mounting devices.

A large gauge manufacturer has ingeniously molded a thread into a gauge cover. The crystal-clear molding is screwed directly into the housing. It is also possible to mold a flange or rim that can materially simplify mounting without sacrifice of strength.

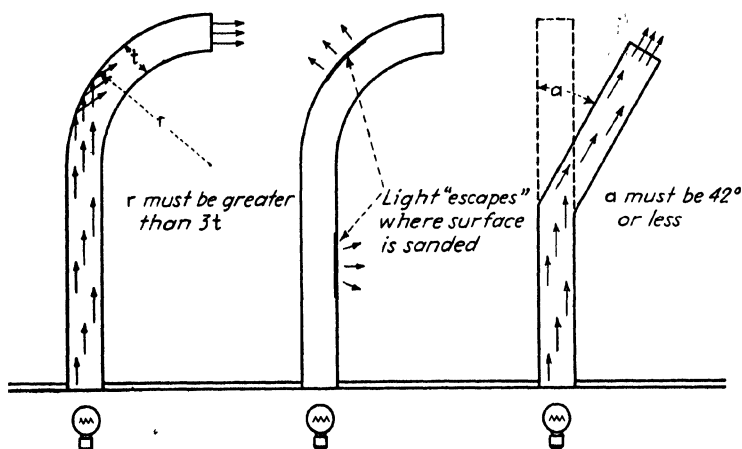

FIG. 62.—Limits of bend angle and curvature radius for cast acrylic parts that are to conduct or pipe light.

Simplified mounting arrangements have also been used by leading manufacturers of radios and automobiles to reduce assembly costs. These applications have also taken advantage of a peculiar property of acrylics—the ability to pipe light from edge to edge with remarkable efficiency. A light bulb placed at the edge of these moldings provides even, glare-free illumination of every marking molded into the piece. If compact design prevents the installation of the bulb directly at the edge of the dial, a curved molding can be used to pipe the light around the corner.

An accompanying diagram (Fig. 62) explains this light piping and its limitations. Acrylic sheets or moldings will pipe light only around a curve whose radius is greater than three times the

thickness of the molding. Acrylics will pipe light through a sheet bent to an angle of 42 deg. or less. Markings in the molding must be arranged properly if an equal intensity of light is to reach all of them.

Besides these optical limitations, there are two practical ones: (1) It is difficult to concentrate enough illumination into the edge of any sheet or molding to permit comfortable reading of printed matter under the light transmitted at the other edge.

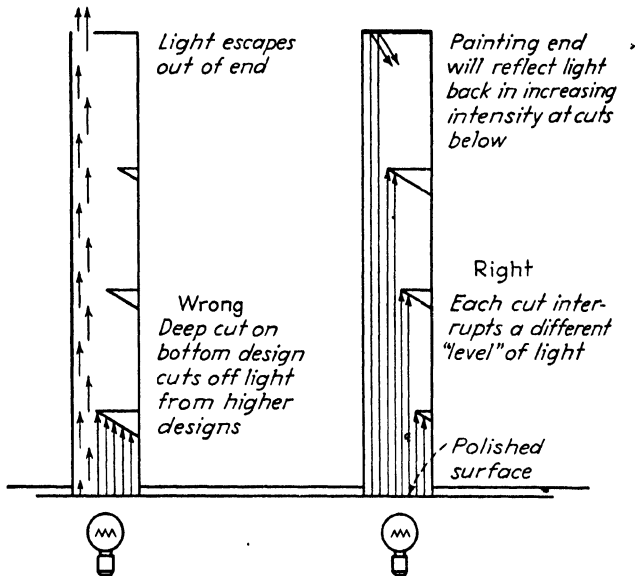

FIG. 63.—Indicating the right and wrong way of designing a molding so as to get uniform intensity of light over all the markings.

(2) The accompanying diagrams (Figs. 62, 63) assume an optically perfect surface free of dust and minor imperfections. Although the surfaces of cast acrylic sheets and properly molded acrylics can closely approximate this perfection, they actually fall short of it; and dust is always present.

Despite these limitations, a small light bulb with the simplest kind of reflector provides satisfactory illumination for a dial 6 to 8 in. long, even though that dial may be bent to a fairly sharp angle. Most of the molded dials on recent cars were more than 1 ft. long and were lighted by only two bulbs, one at each end of the dial.

Although the foregoing discussions have centered on dials molded from powder, the considerations also apply to dials, name plates, and other markings stamped into cast acrylic resin sheets. Before the sheet is stamped or punched, it must be warmed in hot water or on a steam table. By heating the sheets to higher temperatures and using greater pressures, it is possible to emboss the surfaces with deep designs, rosettes, and scrolls to obtain decorative effects. Stamping dies are usually less expensive than molds and stamping is, therefore, used when quantities are small or when the size of the piece involved is larger than available molding facilities can accommodate.

Within the last year the plastics industry has also come to change its conception of the limitations in injection molding of thick sections. The radiator ornament on the new Pontiac—a piece weighing 6 oz. and more than  $\frac{1}{2}$  in. thick in some sections—was injection-molded.

#### AIRCRAFT APPLICATIONS

Designers can learn much from the aircraft industry, where cast acrylic sheets have been used more extensively than in any other field. In 1936, acrylic sheets were used in windows and occasional flat sections to replace glass or other, less stable, plastics. The light weight, impact strength, and permanent transparency were all important.

The ease in forming the sheet led to its use in landing-light covers, cockpit enclosures or "greenhouses," observation turrets, and machine-gun blisters. More recently, aircraft radio engineers have been using acrylic resins to enclose radio antennae, since the resin did not interfere with radio reception. These plastic housings permit mounting of antennae several feet from the nearest metal part without loss of reception efficiency. Numerous other applications of acrylic resins in the design of aircraft are in process of development.

An examination of the properties of acrylic resins makes it obvious why transparent plastic sheet material has been successfully adapted to aircraft applications. For example, the specific gravity is 1.18 to 1.19 as compared with approximately 2.5 for glass; and it is 91 to 92 per cent efficient in transmitting light as compared with 88 to 92 per cent for glass. Moreover, it is thermoplastic and can be shaped when heated. Two- and

three-dimensional curved sections may be obtained for turret and cockpit enclosures to conform to the streamlined design of the rest of a plane. The high-impact strength of the acrylic resins also obviates the necessity for cumbersome braces and supports that might obscure visibility.

Size, shape, and service required of the window or enclosure are considerations that affect the size and type of frames for holding the transparent sections in place. All flat sections and simple curved sections of less than 45 deg. arc can generally be installed in channels without drilling holes through the material.

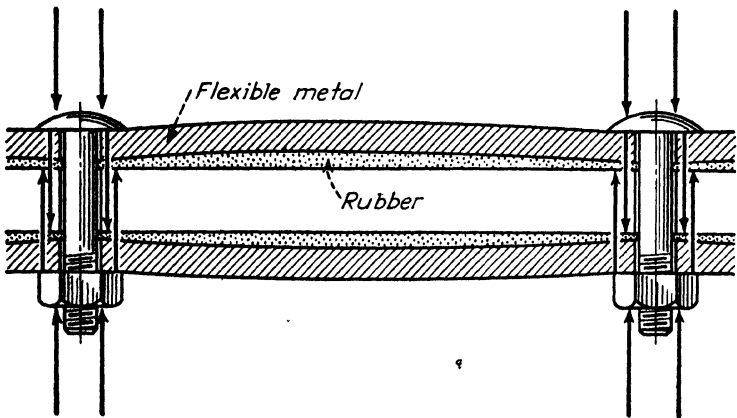

FIG. 64.—Flexible metal strips allow applied stresses to concentrate around bolt holes. In practice, all channel members are likely to be somewhat flexible—hence the need for spacers and other devices to protect the sheet from direct pressure which may cause crazing and failure.

Although landing-light covers may be curved to an arc of more than 45 deg., they can also be set in simple channels. The sections are formed to follow the contour of the leading edge of the wing.

#### MOUNTING ACRYLIC SHEETS

The obvious way to avoid excess pressure is to distribute the total stress over as large an area as practicable. Thus the ideal method of mounting is in an extruded or riveted channel. Here stresses are distributed, to a certain extent at least, all along the edges gripped by the channel. Naturally, the deeper the channel the larger the area carrying the total stress. When steps are

taken to keep the clamping action uniform all along the frame, excess pressure at any one point can be avoided.

Where bolting cannot be avoided, the possibility of high-stress concentrations can be reduced by using a large number of bolts, each carrying an approximately equal share of the load. Also, the more rigid the channel members, the more effectively they will prevent the development of excess compressive stresses around the bolt or rivet holes. Figure 65 shows what may happen if these members are too flexible to distribute the load.

One way to avoid excess pressure on the sheet is to provide tube spacers around the bolt. Long-shank bolts, shoulder rivets, or cap nuts also make it impossible to bring the channel members closer together than the thickness of the sheet plus a reasonable

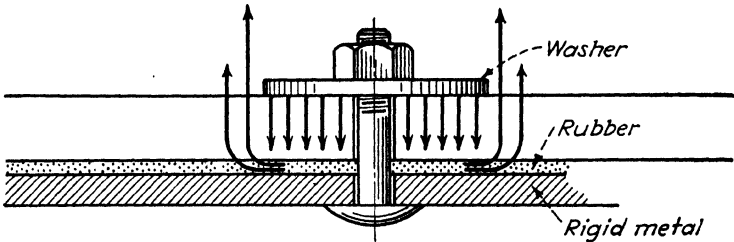

FIG. 65.—Compressive stresses applied at washer are transferred by rubber gasket into shear stresses acting at edge of water.

clearance for thickness variations and for rubber packing. Rubber gaskets do not effectively prevent development of high-stress concentrations. Their principal functions are to make the installation waterproof, to reduce vibration, and to help compensate for thickness variations. Gaskets help to distribute stresses only to a minor extent and only when the stresses are relatively small. When stresses are large, these rubber strips are apt only to transfer them from one small area to another small area and to reverse their direction so that they act almost in shear against the original pressure, as shown in Fig. 66. It is possible for rubber to produce stress conditions that will cause failure.

The term "rubber packing" refers to synthetic or natural rubber strips or combinations of either with cork, fabric, or felt. Strips coated with an adhesive on one side facilitate installation especially in the channel and clamp mountings. The rubber

should be soft (30 to 50 durometer) and should be approximately 0.060 in. thick. The effectiveness of rubber in this respect is twofold: it can be deformed locally to almost one-half its thickness or, by painting the inside of the channel with oil, it can be swollen to double its thickness. Thus a rubber gasket normally 0.060 in. thick might range in thickness from 0.030 to 0.120 in. in a single channel installation.

In addition, there are several so-called "rubber" or mastic compounds, of puttylike consistency when purchased, which harden with age. These compounds may help to make an installation waterproof and possibly to reduce vibration. They do not help to distribute stress. In any case, these compounds should be selected with care since they may contain solvents for the plastic.

#### EXPANSION AND CONTRACTION

The coefficient of expansion of acrylic sheet is  $8 \times 0.00010$  per deg. F., which is higher than the expansion coefficients of materials in which it is mounted. Allowance must be made for the sheet to expand or contract in relation to the expansion of the metal frame, or binding and dangerously high stresses will result.

When a boltless channel mounting is used, the sheet can expand and contract by slipping along the channel, unless the channel clamps the material too tightly at any point. With medium-sized pieces, it is possible to bolt at only one end and to allow expansion by slippage at the other end. With larger pieces, it may be preferable to bolt at the center of the long edge, thereby providing for expansion and contraction at each end.

Wherever the size of the section or design of the frame makes it necessary to drill holes through the plastic and bolt or rivet it to supporting members, the holes in the plastic must be oversize so as to allow some movement of the plastic relative to the metal frame. If the holes in the frame and in the plastic are drilled at the same time, the plastic should be removed and the holes redrilled to the larger size. These oversize holes must be made concentric to the ones in the frame so that the bolt or rivet does not bind at one edge, causing crazing or failure at these holes.

In sections of hemispherical shape similar to an airplane nose or gun turret section, temperature changes will cause the spherical surface to expand or contract as unsupported area. These

changes of contour have given no trouble with sections up to 40 in. in diameter; but it is important that provision be made for radial changes at the circumference, where the section is attached to the supporting frame. Elongating the holes in the supporting attachment is one possibility. Another successful design calls for cementing an annular ring all around the edge and drilling the elongated holes in this ring. The ring also gives rigidity to the sections that facilitates handling.

### RECOMMENDED THICKNESSES

Proper thickness for any given installation is dependent on many factors. The more completely the panel is supported, the thinner the panel that can be used. The following table for Plexiglas serves as a rough general guide for flat panels:

Thickness, In.	Maximum Recommended Area
0.060.....	6 by 6 in.
0.080.....	12 by 12 in.
0.100.....	18 by 18 in.
0.150.....	24 by 24 in.

Pressures acting on the panel must be considered. Shape is also important, for a long narrow panel need not be so thick as a square panel of the same area. Curvature should also be considered, since even a slight bend will add to rigidity and strength. It should be remembered, however, that in forming a three-dimensional section, the sheet is stretched and is thereby thinned out to a degree dependent upon the extent of the stretch.

Ribs cemented to the panel will also add rigidity and strength. The method of installation will in itself affect the choice of thickness in many ways. If the edges are to be routed, moderately thick sheets will automatically be required, although reinforcing ribs cemented along the edges will make possible the use of thinner material in the rest of the panel.

If the installation is in a deep channel, the panel may be flexed through quite a wide range without pulling out; a shallow channel will require more rigid (thicker) sheet. If the panel is bolted, it is less likely to pull out and thinner material may therefore be used.

The pressure differential between one surface of the panel and the other is obviously important. In aircraft installations,

this factor is dependent on aerodynamic considerations, which are, in turn, dependent on the location of the panel on the plane and on the speed of the plane. Since the theoretical maximum differential in these cases is approximately 15 lb. per sq. in., the deflection caused by this pressure at the center of 12 in. diameter disks of various thicknesses has been determined. The accompanying data are intended only as a general guide.

Thickness of 12 In. Diameter Disks of Plexiglas, In.	Deflection under 15 Lb. per Sq. In. Water Pressure, In.
0.125.....	0.65
0.187.....	0.56
0.250.....	0.41
0.373.....	0.23
0.500.....	0.19

#### CHANNEL AND CLAMP MOUNTINGS

Wherever possible, avoid bolting or riveting through drilled holes. Channel and clamp installations are usually preferable for mass production methods and are definitely superior in distributing stress. Precautions are as follows:

1. The channel should be oversized to permit free linear expansion and contraction relative to the frame.
2. When installing, care should be taken to keep the clamping action uniform over all the area clamped.
3. The channels should be deep enough to hold the panel securely despite flexing and thermal contraction. A safe rule is that panels up to 12 by 12 in. in area should extend into the channel 0.625 in. plus the contraction clearance (0.002 in. times the length); larger panels, 1.0 in. plus contraction clearance.

In calculating these allowances, remember that linear sawing tolerances are  $\pm 0.030$  in. for panels up to 12 in. long and  $\pm 0.060$  in. for longer pieces.

**Simple Channel Installation** (Fig. 66): The principles behind the type of installation apply to both H channels and U channels. No bolts, screws, or rivets are used. Where joining or reinforcing the channel involves such fastenings, the edge is cut out to avoid them. A bell-mounted channel, as indicated, makes for faster assembly than sharp-edged channel members and reduces the danger of scratching. In assembly, use rubber strips coated with

adhesive on one side. This packing can quickly be wrapped around the edge and will stay in place while the panel is being inserted.

**Flush Channel Installation (Fig. 67):** One of the advantages of acrylic sheets is that they can be routed along edges to mount as shown. The plastic is held securely, yet the outside surface is flush with the mounting frame. The corner of the shoulder of the

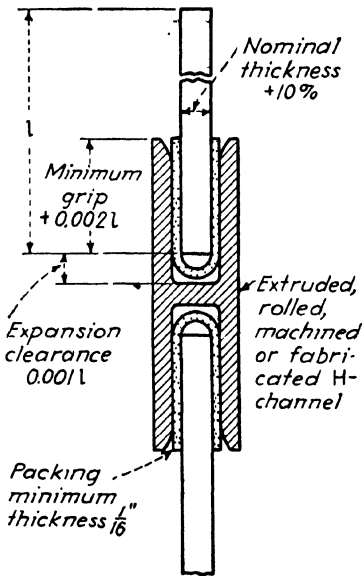

FIG. 66.—Simple channel mounting for acrylic sheet.

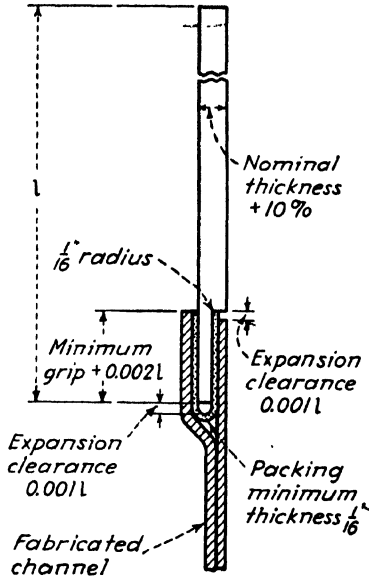

FIG. 67.—Flush channel mounting for acrylic sheet.

route should have a slight radius to reduce the danger of a crack starting at that point. The fabricator can produce this effect by grinding down the sharp edge of the rout cutter. The cutter can be adjusted to maintain close tolerances (+0.010 in.) in either the depth or the toe of the rout. Because of thickness variations in the sheet, it is not possible, in a single routing operation, to maintain these tolerances in both toe and depth. When both these dimensions are critical, a second routing operation is necessary—with a corresponding increase in fabricating costs.

**Flush Installation with Rib (Fig. 68):** The panel may be gripped more securely—without sacrificing the advantages of a flush

mounting—if a reinforcing rib is cemented to the edge and clamped as shown. The relation between the depth and shoulder of the rout and the width and thickness of the rib is complex and cannot be set down in hard and fast rules. If possible,

1. The minimum thickness at any point in the assembly should not be less than the thickness of the panel.

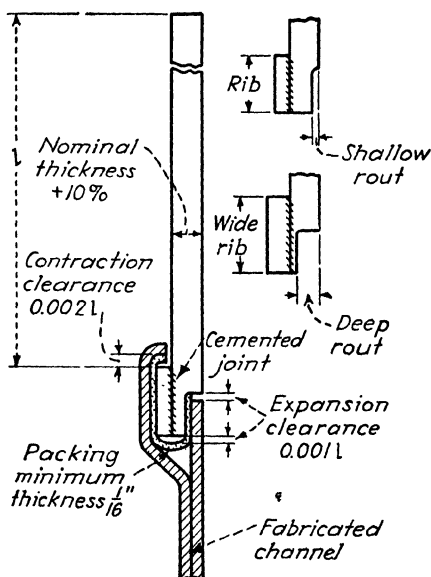

Fig. 68.—Reinforcing ribs strengthen flush installation.

2. The rib should be roughly twice as wide as the thickness since the tensile strength is approximately double its shear strength.

3. The rib should not be the same width as the rout, *i.e.*, the edge of the rib should not be opposite the end of the rout, if concentration of stresses at this point in the assembly is to be avoided.

**Annular Ring Installations** (Fig. 69): For hemispherical sections such as noses and gun turrets, a plastic annular ring is cemented around the whole circumference of the nose or shell. This circumference must first be routed as shown in the sketch so that the two surfaces to be cemented together will be flat and so that the rib will not slip while the cement is setting.

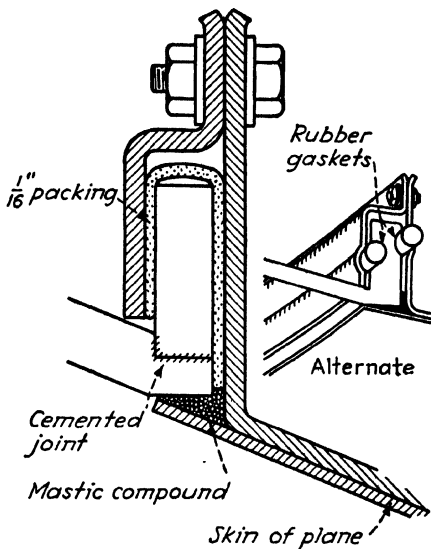

FIG. 69.—Annular-ring mounting for hemispherical sections, such as noses or gun turrets.

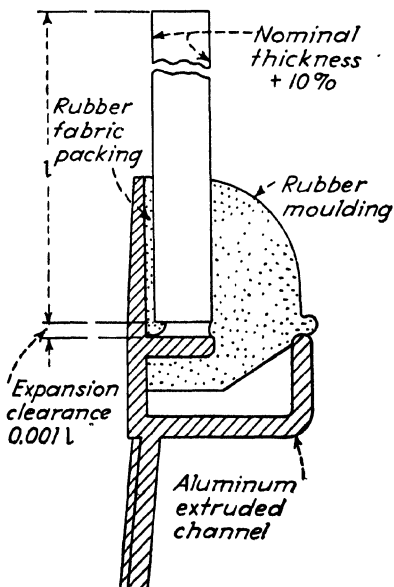

FIG. 70.—Patented frame—an aluminum extrusion. Rubber molding clamps the plastic sheet. (Courtesy of the Hunter-Sash Company.)

Stresses in service will be along the shell. The annular ring acts as a lever, multiplying the bending moments set up in the metal clamping ring. To minimize this lever action, the edge of the ring should follow, as closely as possible, the joint between the annular ring and the shell. The lever action may be used to advantage by inserting round rubber tubing at the indicated points. As pressure increases, these gaskets become tighter and hence seal the joint more effectively. The outer edge of the shell

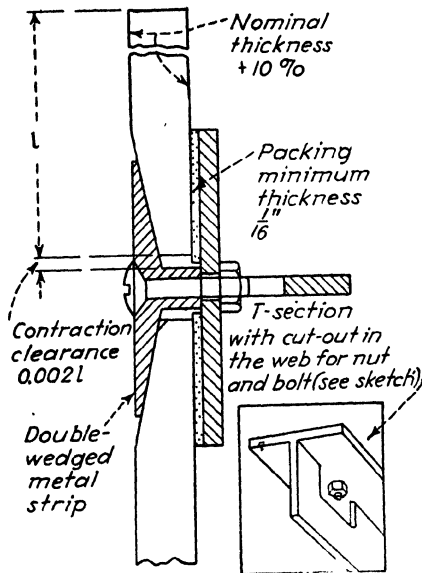

FIG. 71.—Wedge section mounting.

is routed so that the section may be installed after the metalwork is completed and so that it may expand radially.

**Patented Channel Installations** (Fig. 70): The patented frame shown, typical of a number of simple installations, consists of an aluminum extrusion. A rubberized fabric tape is put in position around the inside of the frame and the plastic placed against that tape. Then a heavy rubber extrusion is snapped into position. This extrusion is so designed that any one of a number of thicknesses may be used without changing the dimensions of the aluminum or rubber parts. The sheet is held by the uniform clamping action of the rubber. The possibility of building up concentrated stresses is therefore quite remote.

**Wedge Section Installations (Fig. 71):** When two panels must be installed edge to edge and supported along these edges, the type of installation shown here may be used. The aluminum extrusion is a flat wedge. Either piece may slide freely when expanding or contracting. A shoulder prevents direct pressure. This shoulder bolts directly to the reinforcing member, a T-shaped beam with cutouts in the web for the nut and bolt.

This type of installation is used only with thicker sections where the edge of the sheet can be beveled. This beveling makes possible a flush outer surface, an advantage over the H-channel installation shown in Fig. 66. This type of mounting is often used on only one or two sides of a section, the other sides being mounted in a channel or by some other method.

#### BOLT AND RIVET MOUNTINGS

When special considerations make channel and clamp mountings impractical, holes may be drilled for nut-and-bolt and rivet installations. To assure long service,

1. Use as many bolts or rivets as practical.
2. Distribute the total stress as equally as possible among these bolts or rivets.
3. Make holes sufficiently larger than the diameter of the bolt to permit expansion and contraction relative to the frame.
4. Make holes concentric with the holes in the frame so that the greater relative expansion will not cause binding at one edge of the hole.
5. Use oversized tube spacers, shoulder bolts or rivets, cap nuts, or some other device to protect the panel from direct pressure in installation.

**Rivet and Spacer Installation (Fig. 72):** This type can be used with either a bolt or a rivet as the positive attachment. A tubular spacer protects the panel from direct pressure. Since this spacer is inserted after the sheet is in position, assembly is simple. A modification uses a long-shank screw or shoulder rivet. This modification would differ from the mounting shown in Fig. 74 in the holes drilled in the metal channel members. Here both holes are of the same diameter; in Fig. 74 one hole must be smaller than the other one.

The length of the spacer is calculated to allow for variations in the width of the channel and in the thicknesses of the panel and

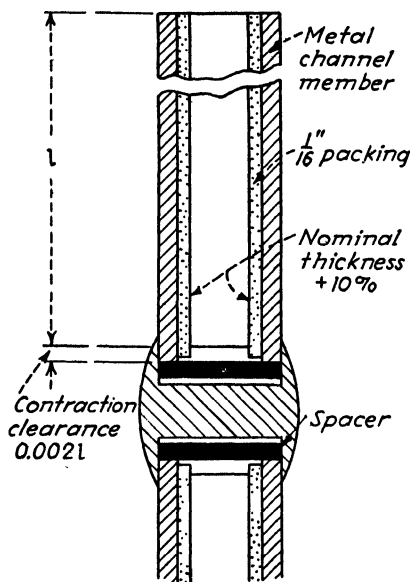

FIG. 72.—Rivet and spacer mounting.

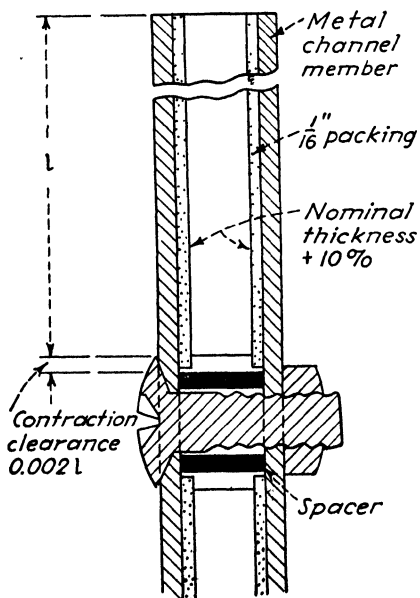

FIG. 73.—Bolt and spacer mounting.

of the rubber packing. Contraction clearance is allowed around the bolt so that in case of extreme temperature changes, the panel will not bind and crack at one edge. The recommended distance from the hole to the edge is the same as the recommended depth of grip in the channel installations.

**Bolt and Spacer Installations** (Fig. 73): In this case the spacer is equal to the inside width of the channel. This permits the use of

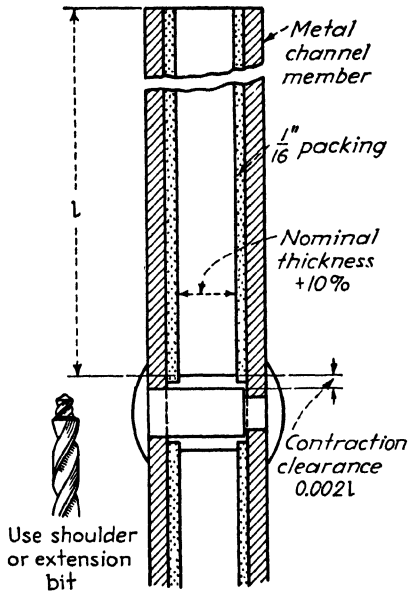

Fig. 74.—Shoulder rivet mounting requires separate drilling of metal members.

countersunk screws as well as rivets, without reducing the protection for the plastic. It is somewhat more difficult to assemble than the method shown in Fig. 72, but satisfactory methods can be worked out to insert the spacers as indicated.

**Shoulder Rivet Installation** (Fig. 74): To eliminate spacers, a shoulder rivet can be used as shown. A shoulder screw could, of course, be used in the same way. The rivet hole in one channel member must be larger than the corresponding hole in the other member. Each member may be drilled separately and assembled later in a jig so that the holes are concentric. To drill both holes in a single operation (after the channel is assembled), there are a number of special bits available, known variously as shoulder,

extension, subland, dual-cut, counterbore, combination, or step drills. One type of standard dual-cut bit is shown.

**Annular Ring and Bolt Installation (Fig. 75):** This type is especially designed for hemispherical sections, such as noses, gun turrets, and navigator's domes. A strip of thick plastic is machined to the indicated cross section and then formed to follow the circumference of the section. This circumference is also routed, on the inside, so that it will fit the annular ring; on the outside, so that

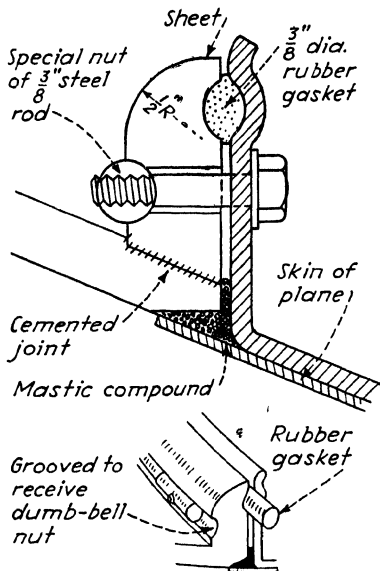

FIG. 75.—Annular ring and bolt mounting.

it can be installed after all metalwork is done. The ring is cemented to the section and the required holes drilled through it from below.

The dumbbell nut and the shape of the ring permit the section to rock slightly when the sheet expands or contracts. Rubber gaskets make the installation pressure-tight. So that excess pressure will not be put on the ring, the bolt is threaded along only a small part of its length.

**Bolt Installations for Small Sections (Fig. 76):** For small sections carrying light loads, the simple installation shown here may prove satisfactory. It should not be used under any other conditions. It should be used only when a cap nut, long-shank

shoulder screw, or some other device is included to prevent pressure on the plastic. The conical rubber grommet does not offer sufficient protection. The head of the screw should have a flat angle. A sharper angle accentuates the wedge action of the screw head tending to split the sheet.

### FORMING

Since it is thermoplastic, acrylic resin becomes soft and pliable when heated to 220 to 300 deg. F. and can then be bent to almost

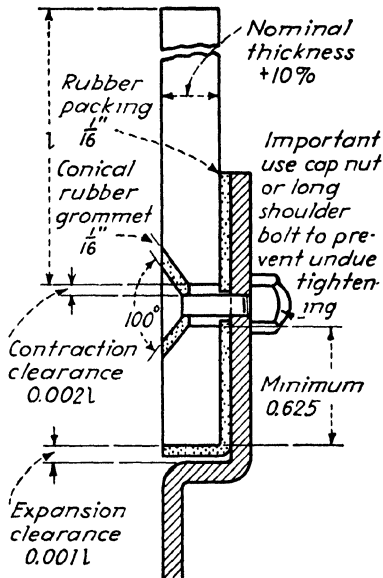

FIG. 76.—Simple installation for small sections and light loads.

any shape. When the material cools, it retains the shape to which it is bent, except for a small contraction caused by the lowering of temperature. Formed material, however, has an elastic or plastic “memory” and will revert to its original flat shape when reheated to the forming temperature.

It is not practical to cold-form or spring the material into a curved frame without heating unless the material is thin and the curve slight. For example, a 16-in. piece, 0.250 in. thick, should not be deflected more than  $\frac{1}{4}$  in. The outer fiber stress on a curved cold-formed piece may cause tiny fissures called

“crazing.” Hot forming is simple and eliminates crazing in curved sections; it is by far the better procedure.

Strains can be kept to a minimum by making sure that the material is thoroughly heated before forming. Complicated shapes require somewhat higher temperatures than simple curves.

On the other hand, when too hot, the surface is very soft and too apt to pick up minor imperfections from the form. Finger-prints, glove marks, and specks of dirt can make a deep surface impression, requiring extensive polishing later.

Probably the best compromise is to heat 15 or 20 min. at the proper temperature, then to allow the surface of the blank to cool a minute or two before letting it come in contact with the form. With experience, the satisfactory degree of pliability can be determined by feeling and twisting the edge of the sheet.

The application of high or even moderately high pressures is neither necessary nor desirable in forming, since it tends to increase the extent of mark-off. The power required to form is much less than that required for soft metals. The heated material can be handled like a sheet of pure gum rubber and approximately the same power is required to stretch it. For simple shapes, especially with thick sheets, the weight of the material is usually sufficient, and only if considerable stretching is involved should much pressure be applied.

Contour tolerances of  $\pm 0.125$  in. can be maintained in most forming operations, but for three-dimensional sections with a deep draw, greater latitude should be allowed.

### HEATING

Ovens heated by steam, electricity, or gas have been found most satisfactory. The temperature should be kept within the 220 to 300 deg. F. range by adequate control equipment and circulating hot air inside the oven. The sheets may be hung vertically in the oven or placed on trays with cloth bottoms.

Remove all masking paper before heating for forming. Then rinse with distilled water or, if tap water is used, dry thoroughly by blotting with soft tissue paper. Any solids in ordinary tap water will bake into the surface if this precaution is not taken.

Boiling water is not satisfactory, except for very thin material, for two reasons: (1) it is not really hot enough and the addition

of salt or glycerine to the water does not raise the temperature sufficiently; (2) water may be trapped between the sheet and the form. If this water vaporizes, it may cause cloudy steam spots on the material.

Hot oil baths are more satisfactory and relatively easy to set up. Their temperatures are high enough and remain fairly constant. If the oil is clean, it does not affect the surface. Oil, however, makes the material difficult to handle and adequate provision must be made for the inevitable dripping and splashing.

### FORMS

Since most forms for acrylics are subjected to no great pressure, they may be made of material as brittle as plaster. The choice among plaster, wood, metal, masonite, and combinations of materials depends on considerations of cost and length of expected service. For simple two-dimensional bends, metal, masonite, or plywood forms are easily made; for more complicated shapes, plaster forms are easier to make and perfectly satisfactory. It is usually advisable to reinforce the plaster with wire and to use strips of metal at the edges—especially for stretch forming where there may be considerable pressure on the edges.

The form should be somewhat larger than the finished piece. This permits the use of slightly oversize sheets, which simplifies handling and compensates for the slight tendency of the Plexiglas to curl away from the form and to flare at the edges. It is helpful to mark a trim line on the form, indicating the limits of the finished piece.

The form should be free of waxes and other variations in contour that might cause optical distortions. The surface should be sanded smooth and covered with soft cloth (such as billiard felt, outing flannel, or imitation chamois) or flocked rubber or suede rubber sheeting. Forms should be kept clean and brushed off before each piece is formed.

In many cases, pieces can be best formed by using a hold-down ring of yoke, fitted to the mold but allowing for the thickness of the sheet between the mold and the ring. This ring should be hinged or otherwise attached to the form so that it will fit exactly when pressed down on the hot sheet. Stops should be arranged to prevent the ring from being forced into the material when pressure is applied. This hold-down ring may be the

exact size and contour of the piece, so that when cooled the piece may be scribed, on the form, around the inside of the ring. Contraction on cooling may be large. The use of a hold-down ring prevents curling away from the form and also permits the use of smaller blanks to obtain the same size of finished piece.



FIG. 77.—Inspecting a newly formed acrylic sheet. (Courtesy of Bell Aircraft Company.)

If there are form marks or mark-off on the surface, the sheet should be put back in the oven. It will resume its flat shape—and its original surface except for scratches—and can then be formed again. It is more economical to re-form several times than to sand and buff out mark-off.

#### STRETCH FORMING

Many three-dimensional shapes can be made by stretching across a form. The material is heated slightly hotter than for

simpler forming, but the surface is allowed to cool slightly, as usual. During this cooling, a number of wooden carpenters' clamps are fastened to the edges, 6 to 10 in. apart. Holding these clamps, a circle of men draw the sheet down around the form. A metal ring can then be clamped in position around the edges.

#### MALE AND FEMALE FORMING

For three-dimensional sections, especially sections of irregular contour, male and female forms may be used, but the method is not recommended. The hot sheet is stretched across the top of one form, usually the female, and held in position by hand or with clamps while the other form is lowered into place. In this method, a long cooling time is required because heat does not dissipate quickly.

The basic objection to this type of forming lies in the fact that both sides of the sheet come in contact with mold surfaces and both are therefore subject to mark-off. This mark-off is often quite severe and may require extensive sanding and polishing. Mechanical or hydraulic presses should not be used. The pressures thus developed are in excess of those required and poor optical properties will result.

#### CEMENTING ACRYLICS

It is possible to obtain a cemented joint closely approximating the original sheet in strength and transparency. The following procedures apply specifically to cementing two pieces of acrylic sheet together. For cementing to metal, glass, wood, or other materials, the following methods may be followed, but it is usually preferable to use a solution of acrylic resin in an organic solvent.

#### TYPES OF CEMENT

Four types of cement may be used in cementing, each offering specific advantages in particular applications.

**1. Monomeric Methyl Methacrylate:** This material is closely related to the liquid resin from which the sheet is originally cast. The same process, polymerization, by which this liquid becomes solid, is made to take place in the cementing procedure.

Since heat, light, and air act to hasten this process of polymerization, it is necessary to add a chemical reducing agent (hydroquinone) to prevent or inhibit the solidification of the liquid in transit. This inhibited monomer will remain liquid one or two months at room temperature and longer periods under refrigeration.

To counteract the effect of the hydroquinone a second chemical, benzoyl peroxide (supplied in a separate capsule), is added before cementing is begun. After the benzoyl peroxide has been added, the monomer will remain liquid only if kept in a refrigerator.

Before starting to cement, add the contents of the benzoyl peroxide capsule to 1 lb. of monomer (or use proportionate amounts of each material) and pour the liquid into a large flat enamel pan or glass container. The solid pieces, taped as described below, may then be dipped directly in the liquid. The sheet is soaked 10 min. to 1 hr. depending on the depth to which the material must be softened to make a satisfactory joint. After soaking, the excess monomer is removed by waving the piece in the air. The sections are pressed in position and held in place with jigs until the joint is hard.

**2. Partly Polymerized Monomer:** The desired quantity of monomeric methyl methacrylate is placed in an enamel or Pyrex glass container of about twice that volume and loosely covered. The liquid is brought to a boil on an electric hot plate with frequent shaking. It has a boiling point approximately that of water but, because of its inflammability, must be kept from an open flame. As soon as the liquid has been brought to a boil, the flask is transferred to a steam bath and the heating continued until the material reaches a viscosity somewhat greater than that of glycerin.

When the desired viscosity is reached, the flask is thoroughly cooled with cold water and placed in a refrigerator until the cement is to be used. In this state, the cement may be applied like glue to whichever surface is more convenient.

**3. Solvent cements:** These depend on their ability to soften the surfaces and are used very much like the monomer cement already described. During the setting time, the solvent evaporates and the sheet hardens again. Of all solvents, ethylene

dichloride is by far the most satisfactory. The use of other solvents, except in emergencies, is to be avoided.

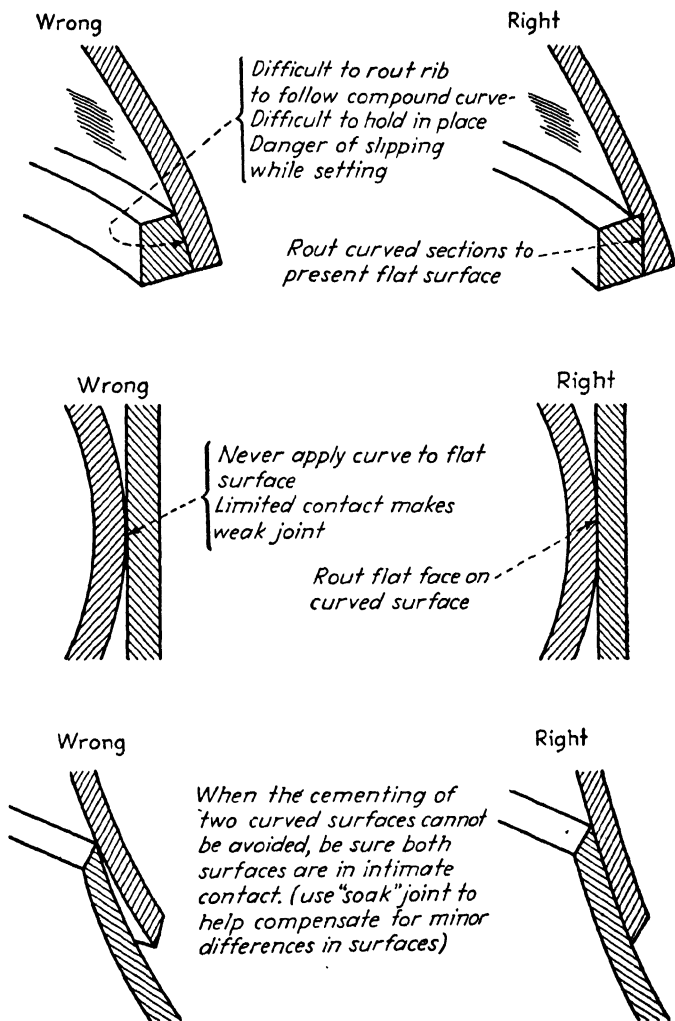

FIG. 78.—Right and wrong methods of joining curved surfaces.

**4. Solvent-polymer cements:** These cements are made by dissolving shavings in acetone, ethylene dichloride, or some similar solvent until a viscous sirup is obtained. If evaporation

of the solvent makes the cement too thick, more solvent may be added. The cement is used very much as partly polymerized monomer is used, but its setting time is shorter. A solvent-polymer joint is apt to be more brittle than the other types.

The choice of cement will depend on a number of factors. Partly polymerized cement is usually used for flat sections and for sections too large to soak, since it is so convenient to apply. Monomer and ethylene dichloride cements are useful when it is difficult to obtain an accurate fit of the two pieces to be cemented. After prolonged soaking, the sheet becomes soft and gummy enough to compensate for slight discrepancies in the fit. Monomer joints are stronger and more reliable than ethylene dichloride joints.

Where the facilities are available and where any considerable amount of cementing is being done, both monomer and partly polymerized monomer would probably be used. In emergency repair kits and in shops where little cementing is undertaken, ethylene dichloride is probably preferable.

### PREPARING THE JOINT

For a satisfactory joint, the two pieces to be cemented should fit accurately. In butt joints, for example, both edges should be true and square. It is advisable to rout or sand curved sections to present flat surfaces before cementing.

Where two curved surfaces are to be cemented, as in an overlap joint of two curved sections, the curves of both should be of the same radius. Surfaces should have a good machine finish or should be sanded smooth. The surfaces should also be cleaned with methanol to remove dirt and dust. Water or dampness may cause cloudiness.

### TAPING

Taping is necessary because both monomer and ethylene dichloride soften the surface and it is necessary to confine this etching action to the area of the joint. The tape used is a tough paper tape impervious to the action of the cement and backed with pressure sensitive adhesive. When partly polymerized cement is used, the tape is applied as closely as possible to the limits of the joint in a band 1 to 2 in. wide.

The viscous cement is applied to one of the surfaces to be cemented and the other section, also taped, is placed in position. Enough pressure is applied to remove all air bubbles from the joint, and the whole assembly is clamped in a jig. By working carefully and by cleaning the joint promptly, it is possible to save a great deal of sanding and polishing time putting the joint in order.

When monomer or ethylene dichloride is used in a soak joint, one section is soaked in the solution—often completely immersed

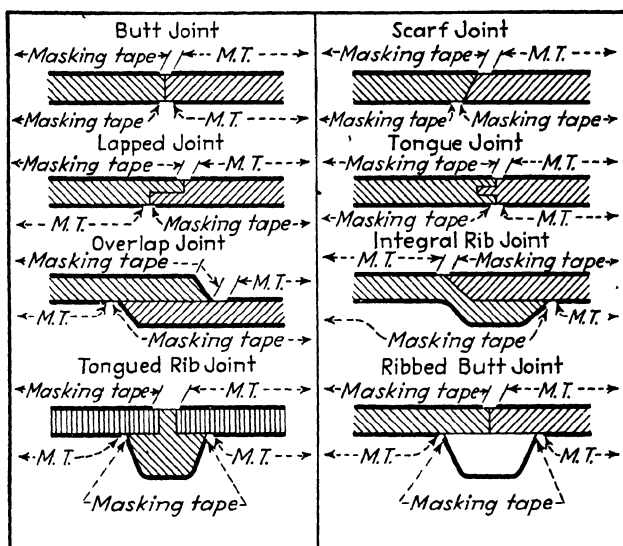

FIG. 79.—Taping for different types of joints. Masking tape is applied to within  $\frac{1}{16}$  in. in "soak" joints and  $\frac{1}{32}$  in. in other joints.

—and should, therefore, be completely protected. The whole piece is taped within  $\frac{1}{32}$  in. of the proposed joint, a margin being allowed for the softening action of the cement. The piece is soaked in the cement 10 min. to 1 hr. until the surfaces are softened to a great enough depth. Ethylene dichloride will require much shorter times.

Excess pressure should be avoided, because of the danger of setting up strains in the joint. The pressure (1) should be enough to squeeze all bubbles from the joint; (2) should be applied evenly all along the joint; and (3) should compensate for the shrinkage that takes place in the joint during setting or hardening.

The joint should be allowed to harden for at least 4 hr. before it is moved from the jig, and another 24 hr. should be allowed to elapse before any strain is placed on it. A joint soaked 1 hr. may require as long as 3 weeks to harden completely. Setting time may be reduced by exposing the joint to sunlight.

The joint should be thoroughly hard before machining, sanding, or polishing. The softened material continues to shrink

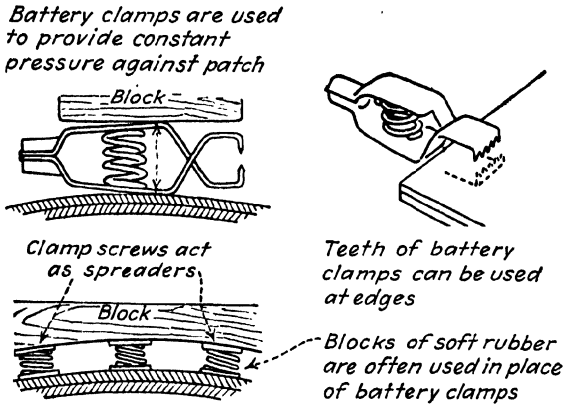

Fig. 80.—Simple methods of applying pressure at joints.

until it is fully polymerized. If the joint is trimmed and sanded too soon, a visible scar will be left along the joint.

### REPAIRING AND PATCHING

**Cracks:** At the first sign of cracking, a hole  $\frac{1}{8}$  to  $\frac{3}{16}$  in. in diameter should be drilled at the end of the crack. This helps to prevent further splitting by distributing the strain over a larger area.

It is also possible to relieve this strain by lacing the crack with strong, flexible wire. A series of holes should be drilled along either side of the crack but at least  $\frac{1}{2}$  in. away from it. A more permanent repair can be effected by patching with a wedge-shaped piece with rounded corners.

**Holes:** The first step is to trim the hole and surrounding cracks to a circle as soon as possible. This will prevent the development of radial cracks and will confine the damage to a minimum area. It may be possible to cut out and insert a

wooden plug, which will serve until a permanent patch can be cemented in place, as described below.

*Cementing patch or crack near edge with wood-working and battery clamps*

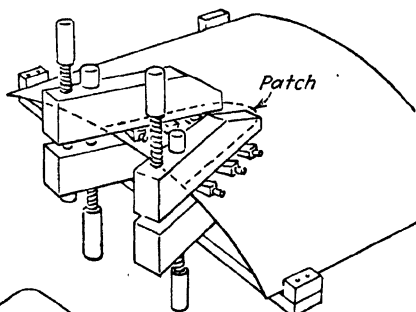

*Cementing rib with jig and clamps*

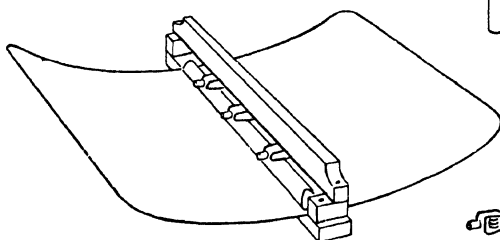

*Reinforcing or patching near edge with battery clamps*

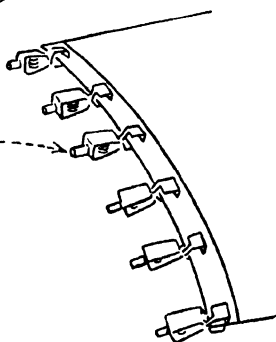

*Where clamps and jigs are not available weights may be used\**

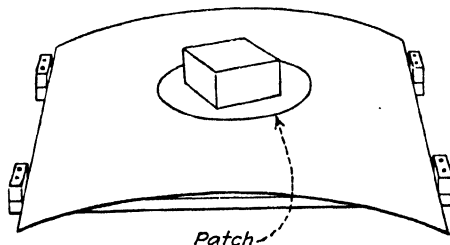

*\* Approximately 10 lb. pressure per inch of joint*

FIG. 81.—Typical jigs for cementing acrylic sheets.

The three guiding principles of patching are (1) the patch must fit perfectly; (2) a firm pressure must be applied evenly to all edges of the patch while the cement is drying; and (3) sufficient time must be allowed for the cement to dry.

The hole is trimmed to a perfect circle or oval and the edges of the hole given a slight taper. The patch is cut out of material

slightly thicker than the section to be repaired and given a more oblique taper than the hole itself. Its edges are heated, then the patch forced into the hole and allowed to cool.

The patch is then removed and both surfaces masked with masking paper. The edges of the patch are allowed to soak in



FIG. 82.—Transparency of acrylics is strikingly demonstrated in this dawn photograph of a line-up of bombers made just before take-off for Britain.

monomeric methyl methacrylate cement or ethylene dichloride until the edges are considerably softened. This may require 30 to 45 min. for monomer or 2 to 3 min. for ethylene dichloride. The patch is then inserted in the hole again. Because the edges are tapered, pressure need be applied on only one surface. It is advisable to leave the patch under light pressure for 24 to 36 hr., and preferably longer, before cleaning it by filing, sanding, and

TABLE 18.—MECHANICAL PROPERTIES OF ACRYLIC RESINS\*

The figures given below are calculated from the indicated A.S.T.M. tests on standard pieces. Since acrylic materials are thermoplastic, however, the properties may be found to vary with the temperature of the material. The figures given for molded are also subject to variation with changes in molding conditions. Wherever possible, therefore, tests under actual service conditions should be made.

	Cast	Molded	Remarks
Hot-forming qualities...	Excellent	Fair	
Molding qualities.....	Good	Excellent	
Forming temperatures (deg. F.).....	230-290		
Molding temperatures (deg. F.):			
Compression.....		300-360	Mold surface temperature
Injection.....		325-450	Cylinder temperature
Molding pressure, lb. per sq. in.:			
Compression.....		1,000-3,000	Positive pressure
Injection.....		Medium to high	Depending on gate size and form of cavity
Compression ratio:			
Compression.....		1.7-2.0	Depending on part size and shape
Injection.....		2-2.5	
Mold shrinkage, in. per in.:			
Compression.....		0.001-0.005	On positive pressure-molded 4-in. disk
Injection.....		0.004-0.006	On injection-molded 5-in. bar
Specific gravity.....	1.185	1.18-1.19	25 deg. C./25 deg. C.
Specific volume, cu. in. per lb.	23.4	23.2-23.5	For the solid resin, i.e., cast or molded objects
Refractive index, $N_D$ ...	1.49	1.49	Dispersion $N_F - N_C = 0.008$
Tensile strength, lb. per sq. in.	7,000-9,000	4,000-6,000	Depending on hardness of resin. Tests at 25 deg. C. and 0.05 in. per min. jaw separation according to A.S.T.M. D229-39
Elongation, per cent at break.	5-15	1-5	Depending on hardness of the material and the perfection of the sample shape. Also on molding conditions for the molded material. Tests at 25 deg. C.
Modulus of elasticity, lb. per sq. in. by 100,000, in tension.	4-6	.....	Determined by tangent to tensile stress-strain curve. Tensile tests conditions according to A.S.T.M. D48-37 at 25 deg. C.
Compressive strength, lb. per sq. in.	11,000-13,000	10,000-15,000	Flow strength measured according to A.S.T.M. D48-37 at 25 deg. C.
Flexural strength, lb. per sq. in.	14,000-16,000	.....	A.S.T.M. D48-37, test at 25 deg. C.
Compression.....		10,000-15,000	A.S.T.M. D48-37 $\frac{1}{2}$ by $\frac{1}{2}$ by 5 in. flash-molded. Test at 25 deg. C. Strength dependent on hardness and molding conditions

\* Data furnished by courtesy of Rohm and Haas Company.

TABLE 18.—MECHANICAL PROPERTIES OF ACRYLIC RESINS—(Continued)

	Cast	Molded	Remarks
Injection.....	.....	10,000-11,000	A.S.T.M. D48-37 $\frac{1}{4}$ by $\frac{1}{2}$ by 5 in. injection-molded. Test at 25 deg. C.
Modulus of elasticity, lb. per sq. in. by 100,000.	4-6	.....	Determined by tangent to flexural stress-strain curve and the formula $E = \frac{4W}{3DT}$ where $W$ = load, $D$ = deflection at load, $W$ and $I$ = moment of area
Impact strength, ft.-lb. Charpy unnotched bar	3.4-3.6	.....	$\frac{1}{2}$ - by $\frac{1}{2}$ - by 5-in. bar, A.S.T.M. D256-38 method at 30 deg. C. Value relatively independent of temp. in range of -20 to 60 deg. C.
Compression.....	.....	1-2	$\frac{1}{2}$ - by $\frac{1}{2}$ - by 5-in. bar, A.S.T.M. D256-38 method at 25 deg. C. Value relatively independent of temp. in range of -20 to 60 deg. C. Spread due to molding conditions
Injection.....	.....	3-4	Measured on an injected $\frac{1}{4}$ - by $\frac{1}{2}$ - by 5-in. bar, A.S.T.M. D256-38 method at 25 deg. C. Value corrected to $\frac{1}{2}$ - by $\frac{1}{2}$ - by 5-in. bar size
Hardness			
Brinell, 10-mm. ball, 500-kg. load,	18-20	18-20 <sup>g</sup>	At about 25 deg. C. Values critically dependent on test cycle. Readings made as rapidly as possible. Values only approximate average
Rockwell, $\frac{1}{4}$ -in. ball, 100-kg. load.	M70	.....	At 25 deg. C. Minor load on; set dial; major load on 30 sec.; wait 30 sec.; major load removed 30 sec.; read <i>B</i> scale. This value more accurate and reproducible than the Brinell number. Test sample $\frac{1}{4}$ by 1 by 1 in.

buffing it to the level of the patched piece. The patch should never be square or have any sharp corners at which strains may develop. An oval or round patch will always prove more satisfactory.

TABLE 19.—THERMAL AND ELECTRICAL PROPERTIES OF ACRYLIC RESINS\*

	Cast	Molded	Remarks
Thermal conductivity, 0.0010 cal./(sec.)(sq. cm.)(deg. C.) (cm.).	1-10	.....	Actually a coefficient of heat transfer from circulating air to material to circulating air at approximately 25 deg. C. temperature differential. Dependent on thickness and speed of air circulation
Specific heat, cal./(deg. C.)(g.).	0.35	0.35	Method of mixtures at mean temperature of 30 deg. C.
Thermal expansion, 0.00010 per deg. C.	8	8-9	At 30 deg. C. Measurement on cast resin is most accurate
Resistance to heat, deg. C. continuous.	140-160	120-140	Without loss of form or dimension or surface. Dependent on residual internal strains resulting from forming or molding operations
Heat distortion temp., deg. F.:	140	.....	A.S.T.M. D48-37 method
Compression .. . . . .	.....	130-160	Dependent on hardness of material and molding conditions
Injection... ..	.....	125-140	Dependent on hardness of material and molding conditions
Tendency to cold flow .. . . .	Very slight	Slight	As compared with thermoplastic resins in general
Volume resistivity, ohms per cu. cm.	10 <sup>15</sup>	10 <sup>15</sup>	Practically independent of preconditioning. Test at about 50 per cent relative humidity
Breakdown voltage, 60 cycle, volts per mil.			A.S.T.M. D149-38T at 30 deg. C. and 0.1 in. thickness. Practically independent of preconditioning
	500	500	Short-time test
	400	400	1-min. stepwise test
Dielectric constant:			A.S.T.M. D150-36T methods
60 cycles .. . . . .	3.4-3.6	3 0-3.1	Bridge method
1,000 cycles . . . . .	3 2	3.3-3.5	Bridge method
1,000,000 cycles .. . . .	3.2	3.1-3.3	Substitution method
Power factor, per cent:			A.S.T.M. D150-36T methods
60 cycles .. . . . .	5-6	5-6	Bridge method
1,000 cycles . . . . .	6	6-7	Bridge method
1,000,000 cycles.....	2.5	2-3	Substitution method

\* Data furnished by courtesy of Rohm and Haas Co.

TABLE 20.—CHARACTERISTICS OF ACRYLIC RESINS\*

	Cast	Molded	Remarks
Water absorption, total immersion:			$\frac{1}{8}$ - by 1- by 3-in. sample. Tentative A.S.T.M. method
Not preconditioned,			Average, as received condition
24 hr. ....	0.3	0.3-0.4	Average values per cent weight gain based on original weight
48 hr. ....	0.5	0.4-0.5	Average values per cent weight gain based on original weight
Preconditioned,			Preconditioned 24 hr. at 50 deg. C.
24 hr. ....	0.4	0.4-0.5	Average values per cent weight gain based on weight after preconditioning
48 hr. ....	0.6	0.6-0.8	Average values per cent weight gain based on weight after preconditioning
Burning rate. ....	Slow		Classified as flame-resistant
Effect of weak acids	Virtually nil		Usually only the effect of equivalent immersion in water
Effect of strong acids. ....	Affected only by oxidizing acids		Oxidizing acids attack surface on short contact and degel on prolonged contact
Effect of age. ....	Virtually nil		Compared to thermoplastics in general
Effect of sunlight. ....	Very slight		Compared to thermoplastics in general
Effect of weak alkalies. ....	Virtually nil		Usually only the effect on an equivalent immersion in water
Effect of strong alkalies. ....	Virtually nil		Usually only the effect on an equivalent immersion in water
Effect of organic solvents . . .	Soluble in ketones, esters, and aromatic hydrocarbons		Solubility dependent on temperature
Effect on metal inserts. ....	None		Also has good retention for inserts due to slight cold-flow tendency
Machining qualities. ....	Excellent		Can be machined and worked in every way that wood or metal can be handled if overheating is avoided
Clarity. ....	Practically perfect		Surface and body clarity of cast material superior to that of drawn silica glass. Clarity on molded objects depends on surface of molds and molding conditions
Color possibilities. ....	Theoretically unlimited		Can be made in a wide variety of transparent, translucent, and opaque colors. Permanency dependent only on the permanency of the added color

\* Data furnished by courtesy of Rohm and Haas Co.

TABLE 21.—ACCELERATED CRAZING TESTING FOR PLEXIGLAS\*

Outer fiber stress, lb. per sq. in.	Nature of exposure	Length of exposure							
		4 hr.	24 hr. †	4 days †	6 days †	16 days	32 days	56 days	120 days
508	Indoor	O.K.	O.K. 0 deg.	O.K. 0 deg.	O.K. 0 deg.	O.K.	O.K.	O.K.	O.K.
477	Outdoor	O.K.	O.K. 0 deg.	O.K. 0 deg.	O.K. 0 deg.	O.K.	O.K.	O.K.	O.K.
945	Indoor	O.K.	O.K. 0 deg.	O.K. 0 deg.	O.K. 10 deg.	O.K.	O.K.	O.K.	O.K.
948	Outdoor	O.K.	O.K. 0 deg.	O.K. 0 deg.	O.K. 5 deg.	O.K.	O.K.	Very slight crazing	Same
1,880	Indoor	O.K.	O.K. 0 deg.	O.K. 0 deg.	O.K. 15 deg.	O.K.	Very slight crazing	Same	Same
2,090	Outdoor	O.K.	O.K. 0 deg.	O.K. 0 deg.	O.K. 15 deg.	O.K.	O.K.	Some crazing	Same
4,030	Indoor	Slight crazing	More crazing 30 deg.	Very crazed 35 deg.	Same	Same	Same	Same	Same
3,520	Outdoor	O.K.	Some crazing 30 deg.	Some crazing 30 deg.	Same	Same	Same	Same	Same

\* The results recommend a maximum stress of 900 to 1,000 lb per sq. in. if extended outdoor service is expected since, within this limit, Plexiglas retains its original transparency and strength indefinitely.

† In these three columns the amount of deflection from the horizontal is given in degrees (estimated).

CHAPTER XI  
POLYSTYRENE MATERIALS  
MANUFACTURE

Polystyrene, known to chemists for over a hundred years, results from a series of reactions by two organic compounds, benzene and ethylene. These are combined to form ethyl benzene and then subjected to a cracking operation under high heat and pressure to remove hydrogen from the molecule. The

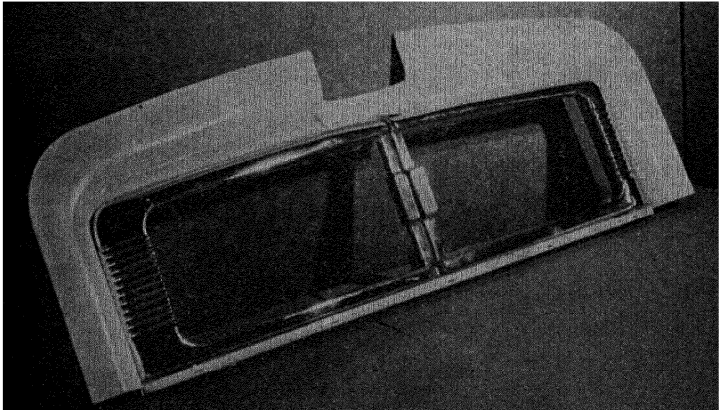

FIG. 83.—Refrigerator panel injection molded of polystyrene.

product of this reaction is styrene monomer, a clear water-white liquid. Polystyrene is derived from this material by polymerization, a reaction that links the individual molecules of styrene in long chains, converting the liquid to a hard, tough, transparent resin. Colored molding materials are made by working dye-stuffs or pigments into the clear transparent material on heated rolls, which knead the plastic and disperse the color. After rolling, the material is removed in rough, uneven sheets, which are allowed to cool and harden. It is then ground to a molding powder.

Polystyrene materials are thermoplastic and therefore can be molded by either compression or injection processes. Compression molding, however, is recommended only for producing sample pieces from available existing molds in order to make experimental studies before starting production.

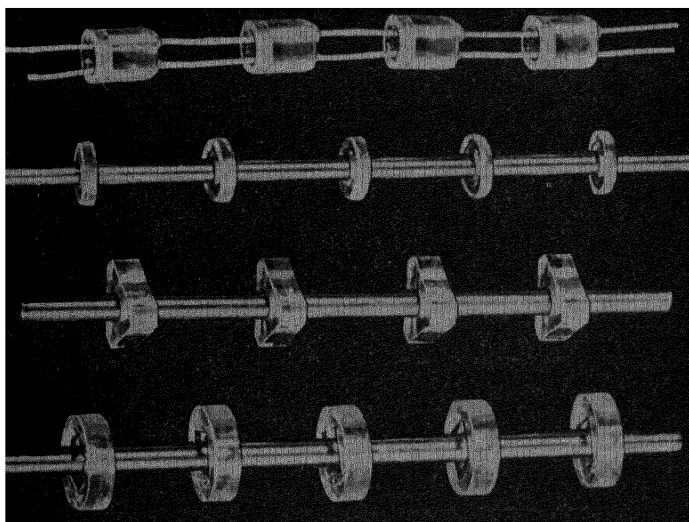

FIG. 84.—High dielectric properties make polystyrene an ideal material for coaxial cable spacers.

### GENERAL CHARACTERISTICS

In compounding the polystyrene molding materials it is not always necessary to include plasticizers to assist or to improve the flow capacity under the application of heat and pressure. As a result such polystyrene parts do not undergo dimensional changes caused by plasticizers vaporizing after the part has been molded. Polystyrene parts on cooling undergo only slight dimensional changes as the part ages.

Another advantage of the absence of plasticizers in polystyrene is that there are no vapors coming from the parts. In the case of materials made with plasticizers, the emanating vapors may cause corrosion of, or chemical reaction with, adjacent parts. Another factor that promotes the dimensional stability of polystyrene parts is the low capacity of the material to absorb water.

Other properties that distinguish polystyrene molded parts are low power factor, high dielectric strength and insulating capacity, low specific gravity, transparency, high-gloss finish, and resistance to alkalis and acids.

#### LIGHT TRANSMISSION AND APPEARANCE PROPERTIES

In translucent and opaque colors polystyrene is only slightly affected by the action of light. Because of its high refractive index and ability to conduct light around bends, as well as to diffuse light at roughened edges, polystyrene is used for many instrument, sign, and indicator parts.

The availability of polystyrene in all colors and pastel shades makes it a desirable material for decorative parts and trim. This appearance value and the fact that the material does not become brittle or lose strength at temperatures as low as  $-30$  deg. C. have led to its adoption for trim and interior parts of refrigerators.

#### RESISTANCE TO ACIDS, ALKALIES, OILS, AND HYDROCARBONS

Polystyrene plastic molded parts soften and swell in acetone. They are soluble in coal-tar hydrocarbons, such as benzol, xylol, and toluol; in chlorinated hydrocarbons, such as carbon tetrachloride and chlorethylene; in acetic esters of the lower aliphatic alcohols; in the hydrogenated naphthalenes, decalin and tetralin; and in solvent naphtha.

Of all the materials in the organic plastics group, polystyrene ranks first in nonabsorption of water; based on 24-hr. tests the water absorption is 0.000 to 0.03 per cent. Polystyrene is insoluble in petroleum hydrocarbons, in the lower aliphatic alcohols, such as ethanol and methanol, in glycol esters, and in lactic acid esters.

#### EFFECT OF TEMPERATURE

The upper limit of temperature for polystyrene parts is about 170 deg. F., as compared with an upper limit of 150 deg. F. for cellulose acetate parts. This relatively low upper temperature limits industrial applications of injection-molded parts.

One interesting characteristic of polystyrene is the fact that the strength of the material increases at low temperature. At 140 deg. F. polystyrene has a tensile strength of 5,000 lb. per

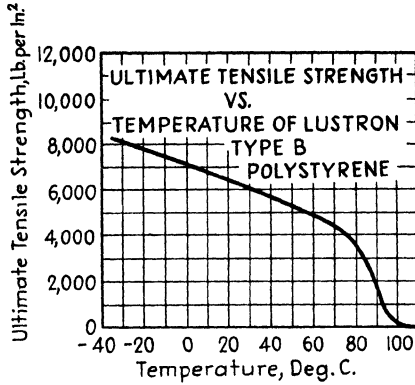

FIG. 85.—Tensile-strength variation with temperature.

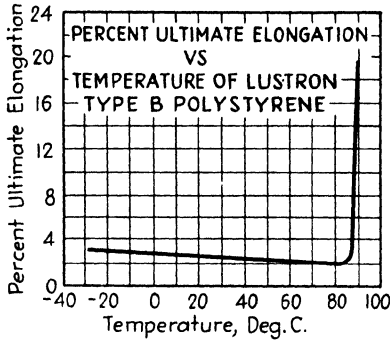

FIG. 86.—Temperature effect on elongation.

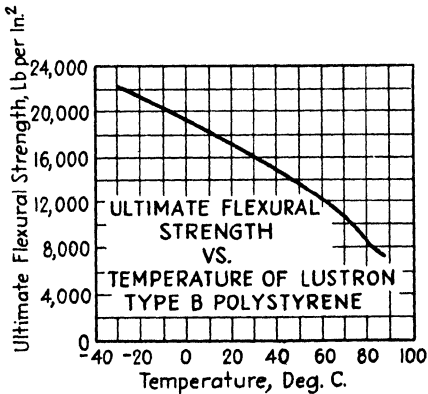

FIG. 87.—Variation of flexural strength with temperature.

sq. in.; at  $-4$  deg. F. the tensile strength is 8,000 lb. per sq. in. This behavior, coupled with the material's low moisture absorption and good dimensional stability, has led to its widespread adoption for many home equipment applications.

#### TYPICAL APPLICATIONS

Polystyrene is used for refrigerator parts exposed to food acids, cleansing agents, variations in humidity, and low temperatures, such as freezing unit doors, drip traps, and food containers, panels, knobs, dials, and breaker strips. Another application is for decorative parts of crystal-clear plastics that have depressed or recessed designs of reversed letters, numerals, or patterns molded into the back surface, and the depressions filled with color. Contrast is obtained by painting the back surface with another color. The material has found acceptance for indirect lighting of instruments, for edge-lighting halo effects, colored light reflectors, indicators, and signs where material having a high refractive index is required.

Among the electrical applications of polystyrene are radio and television coil forms, standoff insulators, sockets, high-frequency lead-ins, and coaxial cable spacers. It may also be molded into closures for containers used to store or to hold during transportation mineral acids and alkaline solutions, instrument housings, speedometer and clock crystals.

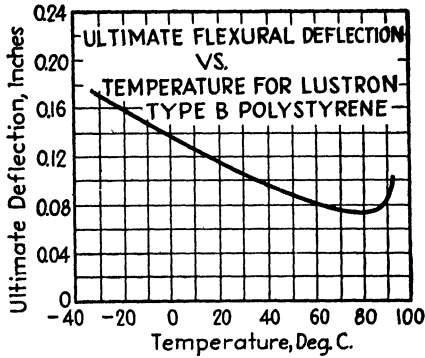

FIG. 88.—Flexural deflection vs. temperature.

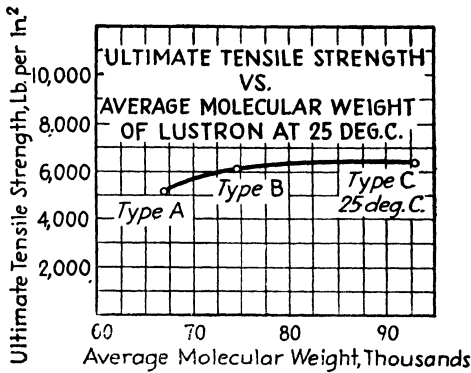

FIG. 89.—Effect of molecular weight on tensile strength.

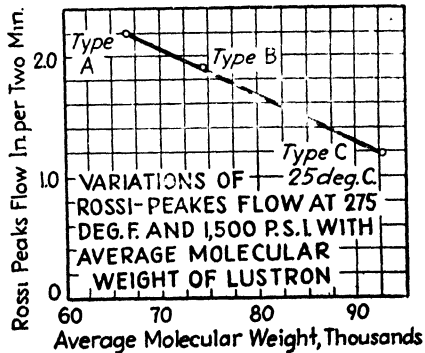

FIG. 90.—Effect of molecular weight on flow.



TABLE 23.—CHEMICAL RESISTANCE PROPERTIES OF INJECTION-MOLDED POLYSTYRENE  
Data obtained from tests made by the Bakelite Corporation

Chemical agent	Time	Effect on samples	Chemical agent	Time	Effect on samples
Hydrochloric acid, conc.	14 mo	Few stars developed	Bromine, liquid	.....	Immediate attack
Hydrofluoric acid, conc.	1 mo.	Stars developed	Chlorine, gaseous, over 25 per cent conc	.....	Immediate attack
Nitric acid, conc.	3 wk.	Turned yellow	Iodine tincture, alcohol 83 per cent	33 mo.	Slight pink discoloration
Nitric acid, conc.	2 yr.	Fell to pieces when handled	Diacetone alcohol	.....	Immediate attack
Nitric acid 50 per cent + hydrofluoric acid 0.5 per cent	25 days	No attack	Ethanol	10 mo.	No attack
Sulphuric acid, conc.	65 mo	Attack extremely yellow	Mercurochrome	1 wk.	No attack
Sulphuric acid 10 per cent + sodium sulphate 2 per cent	33 mo.	No attack	Mercuric chloride	30 min.	Completely dissolved
Acetic acid, 5 per cent	27 mo.	No attack	Milk	2 wk.	No attack
Acetic acid, glacial	14 mo.	Crazed	Phenol 5 per cent + sodium phenate 5 per cent	28 mo.	No attack
Formic acid, 90 per cent	15 mo.	No attack	Phenol 90 per cent	.....	Immediate attack
Tannic acid, 1 per cent, at 170 deg. F	3 wk.	Dark stain developed	Selenium monochloride	.....	Immediate attack
Alcohol, benzol denatured	24 hr.	Softened and dissolved	Sulphonated alcohol	6 mo.	No attack
Alcohol, ethyl, 95 per cent	2 yr.	Crazed	Thionyl chloride	6 hr.	Dissolved
Butanol	27 mo.	No attack	Benzoin tincture, alcohol 80 per cent	2 wk.	No attack
Octyl alcohol	21 mo.	No attack	Titanium tetrachloride	17 mo.	Immediate attack
Ammonium hydroxide, conc.	14 mo.	Few stars developed	Vinegar 25 per cent	13 mo.	No attack
Sodium hydroxide, 40 per cent	9 mo.	No attack	Hydrogen peroxide 3 per cent	22 mo.	No attack
Sodium hydroxide, 30 per cent	21 mo.	No attack	Hydrogen peroxide 3 per cent	.....	Few stars developed
Potassium hydroxide, 30 per cent	15 mo.	No attack	Gasoline, room temperature	1 yr.	No attack
Ethylene diamine, 25 per cent	22 mo.	Turned slightly yellow	Petroleum jelly	15 mo.	No attack
Triethylene tetramine	22 mo.	Turned slightly yellow	Castor oil	2 wk.	No attack
Glycerine	17 mo.	No attack	Corn oil	23 mo.	No attack
Oil of anise	.....	Immediate attack	Coconut oil	17 mo.	No attack
Oil of clove	.....	Immediate attack	Cottonseed oil	23 mo.	No attack
Oil of peppermint	.....	Immediate attack	Olive oil	17 mo.	No attack
Oil of pine	.....	Immediate attack	Carbonated water at 0.3 deg. C	23 mo.	No attack
Orange juice	1 wk.	No attack	Water at 65 deg. C	5 wk.	No attack
Orange peel	1 hr.	Softened and crazed	Water at 75-80 deg. C	2 wk.	No attack
Pineapple juice	3 wk.	No attack	.....	17 days	Surface whitened and became rough
Pineapple juice	10 mo.	Slightly crazed	.....	.....	.....

**HIGH-FREQUENCY INSULATION**

A combination of polystyrene with chlorinated diphenyl of the Aroclor type results in a molding material that shows improved heat resistance, complete nonflammability, and excellent electrical characteristics over wide frequency ranges. The material can be molded by injection or compression. The molded pieces contain less residual internal stress than polystyrene itself; they withstand high temperatures without distorting. The material, known as Styramic, can be extruded into rods, tubes, or other shapes of uniform cross section. It has excellent machinability and can be readily drilled, tapped, or turned.

Examination of Tables 24, 25, and 26 shows that the chlorinated diphenyl-polystyrene compound and polystyrene have much better high-frequency electrical characteristics than other insulating materials. The chlorinated diphenyl-polystyrene compound requires a higher temperature for equivalent flow than polystyrene. The flow is not greatly inferior to that of polystyrene and has excellent moldability.

The unnotched chlorinated diphenyl-polystyrene compound is materially lower in impact strength than the unnotched polystyrene. Notch sensitivity of the chlorinated diphenyl-polystyrene compound is less than that of polystyrene; notched bars have virtually equivalent impact resistance. The impact resistance of Styramic is also of a low order and averages one-half that of the chlorinated diphenylpolystyrene. The A.S.T.M. heat-distortion temperature of the chlorinated diphenyl-polystyrene compound is approximately 15 deg. F. higher than that of polystyrene.

TABLE 24.—PHYSICAL PROPERTIES OF STYRAMIC

Property	Test method	Styramic
Specific gravity, 25 deg. C./25 deg. C.....	.....	1.358
Specific volume, cu. in. per lb.....	.....	20.45
Heat-distortion temperature.....	A.S.T.M. D48-39	84.5–86 deg. C. 184–187 deg. F.
Flow temperature.....	A.S.T.M. D569-40T	138 deg. C. 280 deg. F.
Water absorption, 24 hr., per cent	A.S.T.M. D570-40T	0.046

TABLE 25.—MECHANICAL PROPERTIES\* OF STYRAMIC AND LUSTRON  
(C = compression-molded; I = injection-molded. All tests conducted at 25 deg. C. and 50 per cent relative humidity.)

Property	Molding method	Test method	Styramic	Lustron A
Tensile strength, lb. per sq. in.....	I	A.S.T.M. D638-41T (2)	3,240	6,160
Elongation, per cent.....	I	A.S.T.M. D638-41T (2)	0.97	1.94
Flexural strength, lb. per sq. in.....	I	.....	6,540	13,100
Deflection at break, in.....	I	.....	0.032	0.116
Compressive strength, lb. per sq. in.:				
Yield.....	C	Army Air Corps	11,300	12,550
Ultimate.....	..	.....	11,400	10,800
Compressive strain, per cent:				
Yield.....	C	Army Air Corps	4.1	4.5
Ultimate.....	..	.....	45	43
Young's modulus, p.s.i. × 100,000:				
In tension.....	I	.....	3.34	3.18
In compression.....	C	.....	4.02	3.85
Impact strength, in.-lb. per bar:				
Izod, unnotched.....	C	A.S.T.M. D256-41T	5.7	14.5
Charpy, notched.....	C	(modified)	2.5	2.2
Rockwell hardness.....	C	A.S.T.M. E-18-30	M72	M89

\* Original work, Monsanto Chemical Co., Plastics Div.

TABLE 26.—PROPERTIES OF ELECTRICAL INSULATING MATERIALS\*

Material	Specific gravity	Tensile strength, lb. per sq. in.	Dielectric constant	Power factor			Machinability
				60 C.	1 kc.	1 mc.	
Polystyrene.....	1.05	6,000-7,000	2.6	0.0002	0.0002	0.0002	Good
Skyramic.....	1.36	3,000-3,500	2.6		0.04 (300 kc.)		Excellent
Mycalex.....	3.5	6,000-8,000	6-8	0.006	0.006	0.003	Poor
Steatite.....	2.5	8,000-10,000	6.1	0.01	0.004	0.003	Very poor
Porcelain (dry process).....	2.3	2,000-3,000	6.2-7.5	0.02	0.001	0.007	Very poor
Mica.....	2.8		7.0-7.3	0.0003	0.0002	0.0002	Poor
Quartz (fused).....	2.21	7,000-10,000	4.2	0.0003	0.0003	0.0003	Very poor
Glass, Pyrex.....	2.25	4,000-7,000	4.5	0.01	0.005	0.002	No
Hard rubber.....	1.15	5,000	2-3		0.001	0.005-0.009	Fair
Slate.....	2.8	3,500-10,000	6-8		0.009		Fair
Cellulose acetate.....	1.3	5,000-7,000	3.5-6.4	0.01-0.06	0.01-0.06	0.01-0.05	Excellent
Urea formaldehyde.....	1.45		7.6-8.6	0.04-0.06		0.03-0.04	Good
Phenol formaldehyde:							
Wood filled.....	1.25-1.5	4,000-11,000	5-12	0.04-0.3	0.04-0.15	0.03-0.1	Good
Mineral filled.....	1.6-2.0	4,000-10,000	5-20	0.1-0.3	0.1-0.2	0.005-0.1	Fair
Fabric filled.....	1.3-1.4	6,500-8,000	5-10	0.08-0.3	0.08-0.2	0.04-0.1	Good
Polymethyl methacrylate.....	1.19	7,000-9,000	3.5	0.06	0.06	0.025	Good

\* Monsanto Chemical Co.

## CHAPTER XII

### VINYL PLASTICS

The commercial plastic materials in the vinyl resins are derived from the polymerization of compounds containing the vinyl ( $\text{CH}_2\text{-CH}$ ) group. Belonging to the same chemical group as the styrenes and acrylics, these resins are thermoplastic and therefore do not undergo chemical change under heat and pressure. At the present time, there are four basic types available: vinyl chloride-vinyl acetate copolymer, polyvinyl acetate, polyvinyl chloride, polyvinyl butyral. When suitably modified, the copolymer and chloride resins can be injection-molded, extruded, produced as clear or colored sheets, made into elastomeric sheeting or film, or dissolved in solvents for use in protective coatings that are applied to metals. Other applications of these versatile resins are as calendered or solution coatings on paper and fabrics, as industrial adhesives, or as interlayers for high-test safety glass. They are being used as protective coatings for cloth. These resins are odorless, tasteless, nontoxic, light in weight, and are nonflammable or slow-burning.

#### COPOLYMER RESIN: (VINYL CHLORIDE-VINYL ACETATE COPOLYMER)

By varying the degree of polymerization and the ratio of vinyl chloride to vinyl acetate, a number of resins are obtained with certain properties that make them suitable for many varied industrial applications. The most widely used of the commercial vinyls, these thermoplastic resins possess extreme chemical resistance, which makes them adaptable to products operating under severe conditions. Notable among their chemical properties are inertness to alkalies, oxidizing agents, and most inorganic acids. Water alcohols, grease, fats, or aliphatic hydrocarbons have no effect on the vinyls, but they are swelled or dissolved by ketones, chlorinated hydrocarbons, aldehydes, esters, aromatic hydrocarbons, and certain organic acids.

Vinyl copolymer resins, modified with fillers, plasticizers, and pigments or dyes, are available to the mechanical design field in a number of forms, such as flexible sheeting and films, rigid sheets, and molding or extrusion compounds. Other copolymer resins of the same chemical family are dissolved in organic solvents to produce tough and chemically resistant surface coatings. Vinyl coatings are being extensively used as protective and insulating sheathings for electrical cable and wire.

### CHARACTERISTICS

Water absorption of this material is less than 0.1 per cent for 24-hr. immersion, negligible except in those cases where better than average electrical properties are the primary consideration. In this regard, copolymer vinyl is second only to polystyrene in not being affected by exposure to conditions of high humidity or actual immersion in water. Flat sheets of this material have been used as windows for spinning frames in rayon plants. In this application, the large-area sheets are continually exposed to high humidity as well as chemicals, yet show no distortion or fogging over long periods of service.

Molded copolymer vinyl is dimensionally stable under ordinary conditions of use. Distortion of molded plastics is usually due to water absorption or loss of plasticizer; copolymer vinyl compounds are self-plasticized and the effect of water on the material is practically nil. Because of dimensional stability they are used for injection-molded spray pump parts where a close fit between the piston and the barrel is necessary for proper functioning.

Another feature of copolymer vinyl is that it has greater rigidity than most thermoplastics for a given cross section, an important consideration in the design of many articles. Tests of deformation at instantaneous and constant loading have shown that there is a rather wide difference between cellulose materials and the two vinyls, polystyrene and copolymer vinyl, with the latter being appreciably less affected than any of the materials tested.

### TYPES AND APPLICATIONS

Rigid sheets are available in all colors, transparent, translucent, or opaque, with either a calender, press-polished, or mat

finish, and in thickness from 0.005 to 0.125 in. These sheets are tough, chemically resistant, and nonflammable. Because of their low water absorption and lack of physically incorporated plasticizers, they will not warp or shrink on aging or under varying atmospheric conditions. Being thermoplastic, these sheets may be formed and shaped under heat as desired. They may be deep-drawn, blown, spun, swaged, or formed around a mandrel into three-dimensional shapes. Because they have no surface warpage or slight shrinkage to distort vision or change dimensions, these rigid sheets are finding use as watch crystals, drawing instruments, slide rules, radio and refrigerator dials, calculating and navigating instruments, and aircraft windows.

The properties found in the flexible sheeting and rigid sheets are also present in copolymer molding and extrusion compounds. Both unplasticized, rigid compounds and highly plasticized, elastomeric molding compounds are available in a wide range of colors. Articles produced from the rigid molding compounds are strong and free from warpage, possess great chemical resistance, and do not absorb moisture.

The outstanding characteristic of the highly plasticized extrusion compounds is their flexibility. This property and others, such as chemical resistance, flammability, transparency, and electrical characteristics, depend on the formulation of specific compounds. The principal uses include wire and cable insulation and flexible rod and tubing.

The properties of vinyl copolymer resins also make them suitable for surface-coating applications. When applied from solution in organic solvents, they yield finishes with toughness, gloss, and chemical resistance. Because they are incompatible with most of the common drying oils, these resins are generally the sole film-forming constituent. The coatings may be applied to a wide variety of surfaces. Although air-drying finishes have been developed, it is usually advisable to bake the coatings in order to release solvents and obtain maximum adhesion.

The toughness, adhesion, and flexibility of the vinyl copolymer resins in surface-coating applications make them especially suited for finishes on sheet metal that is to be fabricated after being coated. Parts may be stamped, spun, or drawn from the coated sheet without cracking or rupturing the resin film. This metal

coating is widely used in chemical processing and related industries for protection of equipment and as linings for drums, tank cars, and metal containers.

### INJECTION-MOLDING FACTORS

In the molding of copolymer vinyl a high injection velocity is required, which should be maintained through the entire stroke. The pressure should not drop until the casting has cooled to injection temperature. For most applications, copolymer vinyl can be molded satisfactorily at the 15,000 to 20,000 lb. per sq. in. pressure common to most machines, although in some cases higher pressures are necessary. This material differs from other thermoplastics in that it attains its maximum plasticity at about 310 deg. F. Increasing the temperature beyond this point results only in scorching the material. Therefore, when difficult mold conditions are encountered, the best remedy is to increase the injection pressure, enlarge the gates, or both, rather than to increase the temperature still further.

The temperature-plasticity characteristics of copolymer vinyl are responsible for its having much less tendency to flash in the mold than other thermoplastics; also its heat-energy requirements are considerably less. They are of the order of two-thirds to one-half as much as required for other thermoplastics, when considered for equal volumes and plasticities. For best results in the molding of copolymer vinyl, the cylinder temperature should be 280 to 300 deg. F., and it should not be allowed to exceed 320 deg. F.

Mold design does not differ greatly from that used for other thermoplastics. Short travel of the material, highly polished gate and sprue surfaces, and provision for suitable cooling of the mold are desirable for injection molding. One factor that should not be overlooked in mold design is that copolymer vinyl, owing to a low shrinkage, may stick to undercuts that have not given trouble with other materials. Also because of its low shrinkage and its excellent reproduction of mold surfaces, the molds for copolymer vinyl should be highly polished, although not necessarily chromium-plated. The low shrinkage factor, in addition to brighter castings from the mold, also means less trouble from freezing around core pins, and permits relatively thick cross sections to be molded without so-called "shrink marks."

### POLYVINYL ACETATE RESINS

Polyvinyl acetate resins are thermoplastic powders, which are nontoxic, tasteless, odorless, and slow burning when ignited. They are stable to both heat and light, and resist weak acid, alkaline, and salt solutions. Unlike the copolymer resins, they are soluble in practically all the common solvents with the exception of water, aliphatic hydrocarbons, glycols, the higher alcohols, oils, and fats. An outstanding property of polyvinyl acetate resins is their excellent adhesion to a wide variety of surfaces. They are supplied in a number of grades, which vary in their degree of polymerization or molecular weight. Solution viscosity, toughness, and softening temperatures increase with ascending molecular weight.

Polyvinyl acetate resins are used extensively as adhesives for bonding cloth, paper, cardboard, porcelain, metal, mica, stone, leather, wood, glass, and plastic sheets and films. Other commercial uses include high-gloss and oil-resistant paper coatings, leather finishes, and sizes for textiles, felt, and straw. Highly filled compounds are used for molding and also for making a resin-bonded plastic wood.

Adhesives made from the modified polyvinyl acetate resins are suitable for producing strong, impact-resistant bonds between impervious surfaces, such as metals and phenolic or urea plastics. They have been adopted as the standard materials for making metal-to-metal bonds in a number of commercial applications. The bond strength in high-tension tests of bonded metal samples indicates a shear strength of about 6,000 lb. per sq. in.

### POLYVINYL CHLORIDE RESIN

Polyvinyl chloride resin has high resistance to concentrated acids, alkalies, and alcohols. Its water absorption is practically nil, and it will not support combustion. Because of its toughness and low plasticity, the polyvinyl chloride resin is plasticized for most uses. The resulting plasticized material may be calendered, extruded, or molded with standard equipment.

### USES

Polyvinyl chloride resin when plasticized has found wide industrial use as a rubberlike material. The plasticized resins

TABLE 27.—VINYL COPOLYMER INJECTION-MOLDING COMPOUND\*

Physical Properties	
Specific gravity, g. per cc.....	1.34-1.36
Specific volume, cu. in. per lb.....	20.5
Specific heat, cal./(deg. C.)(g).....	0.244
Thermal expansion, per deg. C.....	$7 \times 10^{-5}$
Electrical resistivity at 30 deg. C., ohm per cm. cube	$> 10^{14}$
Breakdown voltage (60-cycle alternating current), volts per mil.....	650
Power factor:	
60 cycles.....	0.01-0.04
1,000 cycles.....	0.01-0.02
1,000,000 cycles.....	0.01-0.02
Mold shrinkage, in.....	0.001 max.
Mechanical Properties	
Tensile strength, lb. per sq. in.....	8,000-10,000
Hardness, Brinell, 550 lb., 3 min. ....	12-15
Softening temperature, deg. F....	140-150
Izod impact strength, ft.-lb. (notched specimen)	0.3-0.6
Modulus of elasticity, lb. per sq. in.....	350,000-410,000
Modulus of rupture, lb. per sq. in.....	10,000-13,000
Dielectric strength, short-time volts per mil, $\frac{1}{8}$ in. thickness.....	400-500
Dielectric constant:	
60 cycles.....	3.2-3.6
1,000 cycles.....	3.2-3.4
1,000,000 cycles.....	3.0-3.4
Chemical Properties	
Effect of aging, at room temp.....	Unaffected
Effect of sunlight.....	Darkens with prolonged intense exposure
Effect of ultraviolet light.....	Darkens with prolonged intense exposure
Effect of water—hot.....	Softens (140-150 deg. F.)
Effect of water—cold.....	Unaffected
Water absorption, per cent in 168 hr. immersion.	0.1
Resistance to	
Weak acids.....	Excellent
Strong acids.....	Excellent
Weak alkalies.....	Excellent
Strong alkalies.....	Excellent
Alcohols.....	Excellent
Ketones.....	Poor, dissolves
Esters.....	Poor, dissolves
Aromatic hydrocarbons.....	Poor, swells
Aliphatic hydrocarbons.....	Excellent
Mineral oils.....	Excellent
Animal oils.....	Excellent

\* Courtesy of Carbide &amp; Carbon Chemical Corp.

are superior to rubber in flexing life, and in resistance to sunlight, oxidation, acids, and other chemicals. Plasticized extrusion mixes are used for the production of electrical cable coatings, flexible tubings, and gaskets. This resin is also used in solution as a chemically resistant and waterproof finish on fabrics.

### POLYVINYL BUTYRAL RESINS

Polyvinyl butyral resins are characterized by their toughness and colorless transparency. They are soluble in alcohols, glycol-ethers, and esters; they are insoluble in water and aliphatic hydrocarbons and are swelled by ketones and chlorinated hydrocarbons.

### USES

Polyvinyl butyral resins are used primarily as flexible sheeting for the interlayer in high-test safety glass. This layer does not discolor when exposed for long periods to ultraviolet light, absorbs shocks to a large degree, does not shatter at low temperatures, and has excellent adhesion to glass—no edge sealing or special adhesive being required. In addition to this large use in safety glass, these resins have found commercial application as adhesives.

TABLE 28.—COMPARATIVE PHYSICAL PROPERTIES OF VINYL RESINS\*

Series of resin	Polyvinyl acetate resins	Polyvinyl chloride resin (plasticized)	Copolymer resins (no filler)†	Polyvinyl butyral resins
Specific gravity, 20 deg. C./20 deg. C.	1.191	1.2-1.6	1.34-1.37	1.11
Specific volume, cu. in. per lb. ....	.....	23.0-17.3	20.7-20.4	.....
Refractive index, 20 deg. C. ....	1.4665	1.544	1.53	.....
Tensile strength, lb. per sq. in. ....	1,500-4,600	1,000-9,000	8,000-10,000	8,100-8,500
Distortion under heat, deg. F. ....	103	.....	140-150	130-140
Water absorption, immersion. ....	1.4 per cent in 16 hr. at 25 deg. C.	.....	0.1 per cent in 168 hr. at 25 deg. C.	3-5 per cent in 16 hr. at 60 deg. C.
Clarity. ....	Transparent to opaque	Transparent to opaque	Transparent to opaque	Transparent
Color possibilities. ....	Unlimited	Unlimited	Unlimited	Unlimited

\* Courtesy of Carbide & Carbon Chemical Corp.

† The properties of the base resins can be varied markedly by the addition of proper filler and plasticizers.

## CHAPTER XIII

### VINYLDENE CHLORIDE

The basic materials used to produce vinylidene chloride are petroleum and brine. The petroleum is cracked to form ethylene; chlorine is electrolyzed from brine. These chemicals are then combined to form trichlorethane, which is then converted to vinylidene chloride. Polyvinylidene chloride plastics are commercially known as Saran. This plastic material has been under development by the Dow Chemical Company for more than ten years.

Outstanding among the characteristics of vinylidene chloride is resistance to chemicals and solvents. At room temperature, it is extremely resistant to all acids and to common alkalis, except for concentrated ammonium hydroxide. Slight discoloration with little change in mechanical properties occurs on exposure to concentrated sulphuric acid or caustic over long periods. This plastic is extremely resistant to both aliphatic and aromatic hydrocarbons, alcohols, esters, ketones, and nitro-paraffins. This resistance to chemicals or solvents decreases with a rise in temperature.

Another important characteristic is its extremely low water absorption and vapor transmission. According to A.S.T.M. Test No. 570-40T over a period of 24 hr., it shows a water absorption less than 0.1 per cent. This low value accounts for its dimensional stability and freedom from warpage under a wide range of moisture exposure conditions.

Since Saran is thermoplastic, it has a definite softening point that limits the temperature at which it can be used. Softening points vary with composition, the upper limit of operating temperature varying from 150 deg. F. or lower to 250 deg. F. Exposures to much higher temperatures are not dangerous since the material is not flammable.

#### FABRICATION

Like other thermoplastic materials, Saran can be injection-molded, compression-molded, or extruded. Injection-molding

machines for Saran must be modified in those zones where the plastic is held at elevated temperatures in the same general way as described under extrusion. In injection-molding other thermoplastics, the use of cold dies hastens the cooling of the plastic part and shortens the cycle. With vinylidene chloride, the reverse is true. Cold dies produce soft, flexible, amorphous pieces. Rapid hardening is attained through recrystallization produced by heat-treatment in heated dies. For normal sections, this permits short cycles; with heavy sections, heated dies allow the section to retain its heat. Thus it recrystallizes rapidly. Under such conditions, vinylidene chloride can be ejected from the die at temperatures as high as 70 to 80 deg. C. in a strain-free, warp-free, dimensionally stable form. This allows rapid cycles with heavy sections. Moldings have been produced with  $\frac{1}{4}$ -in. sections in a 17-sec. cycle.

Compression molding requires careful selection of metals for the dies. This is covered in the discussion of extrusion. As with other thermoplastic materials, economic considerations will usually influence the choice of injection over compression molding.

This plastic is particularly adapted to extrusion. Modifications in the usual equipment are relatively minor but are necessary for successful extrusion. Iron- and copper-base metals catalyze thermal decomposition in hot zones above 130 deg. C.; hence other metals must be used for these heated sections. The metals that can be used in contact with the plastic above about 130 deg. C. are magnesium alloys, nickel, Z-nickel, Hastelloy-B, Stellite 19, and other chrome-nickel alloys.

#### EXTRUDED TUBING\*

Saran tubing is being produced commercially by a number of licensed fabricators in seamless, continuous lengths. It is at present available in sizes from  $\frac{1}{8}$  to 2 in. in diameter.

This plastic is particularly suited for tubing because of its relatively sharp melting point and resultant retention of physical properties within the service temperature range. Another advantage is its comparatively high bursting pressure. Some individual tests on  $\frac{1}{4}$  in. o.d. by 0.037 in. wall tubing at 25 deg. C. (77 deg. F.) have shown strength of 2,250 lb. per sq. in. Working

\* From a paper by C. B. Branch and D. L. Gibb, Dow Chemical Co., 1942.

fiber stress for various tubing sizes is illustrated by Fig. 91. This curve shows the change in recommended working fiber stress with temperature variations. To use this curve in determining working bursting pressures for tubing of specific sizes and wall thicknesses, the following formula should be employed:

$$\text{w.f.s.} = \text{w.p.} \times \frac{\text{o.d.}^2 + \text{i.d.}^2}{\text{o.d.}^2 - \text{i.d.}^2}$$

where w.f.s. = working fiber stress.

w.p. = working pressure.

o.d. = outside diameter.

i.d. = inside diameter.

For safety, the bursting pressure has been reduced by a factor of 5 in order to obtain the recommended working pressure. This, combined with the fact that the bursting pressures and fiber stresses employed in determining the above curve are based on the minimum figures of large numbers of production batches, makes the figures obtained from this formula very conservative.

TABLE 29.—PROPERTIES OF SARAN TUBING\*

Mechanical Properties	
Bursting strength.....	See Table 30
Ultimate elongation.. . . . .	15-25 per cent
Impact strength, ft.-lb. energy to break $\frac{1}{2}$ by $\frac{1}{2}$ -in. notched bar,	ε
Izod.....	2-8 ft.-lb. per in.
Hardness (Rockwell Superficial 15Y).....	71
Hardness (Rockwell M).....	38
Tensile strength, ultimate.....	4,000-6,000 lb. per sq. in.
Compression strength, yield point	7,500-8,500 lb. per sq. in.
Modulus of elasticity, tension, lb. per sq. in. $\times$ 100,000.....	0.7-2.0
Flexural strength.....	15,000-17,000 lb. per sq. in.
Thermal Properties	
Thermal conductivity.....	0.00022 cal./(sec.)(sq. cm.)(deg. C.)(cm.)
Specific heat.....	0.32 cal./(deg. C.)(g.)
Resistance to heat (continuous)	Satisfactory up to 175 deg. F. (80 deg. C.)
Heat-distortion temperature.....	150-180 deg. F. (66-82 deg. C.)
Tendency to cold flow.....	Slight
Coefficient of thermal expansion	$15.8 \times 10^{-5}$ per deg. C.
Melting point.....	310-325 deg. F. (155-163 deg. C.)
Extrusion temperature.....	Up to 375 deg. F. (190 deg. C.)
Injection-molding temperature...	300-400 deg. F. (149-204 deg. C.)
Mold shrinkage, injection.....	0.008-0.12 in. per in.

\* Courtesy of Dow Chemical Co.

TABLE 29.—PROPERTIES OF SARAN TUBING.—(Continued)

Electrical Properties

Volume resistivity, ohm per cm., 50 per cent relative humidity, 25 deg. C. (77 deg. F.).....	10 <sup>14</sup> –10 <sup>16</sup>
Breakdown voltage, 60 cycles, volts per mil, instantaneous . . .	3,000 volts per mil at 1 mil 1,500 volts per mil at 20 mils 500 volts per mil at 125 mils
Power factor, 60, 1,000, 1,000,000 cycles.....	0.03–0.15
Dielectric constant, 60, 1,000, 1,000,000 cycles.....	2.5–5.0

Optical Properties

Refraction index.....	1.61
Clarity.....	Translucent to opaque

General Properties

Specific gravity.....	1.68–1.75
Specific volume.....	15.8–16.6 cu. in. per lb.
Water absorption, 24 hr. at 25 deg. C. (77 deg. F.).....	0.00 per cent
Water absorption, 168 hr. at 75 deg. C. (167 deg. F.) . . . . .	0.5 per cent
Water permeability.....	Negligible
Corrosion resistance.....	Excellent
Effect of metal inserts . . . . .	None
Machining qualities . . . . .	Good
Burning rate.....	Self-extinguishing
Fatigue resistance. . . . .	Excellent
Effect of sunlight.....	Darkens slightly

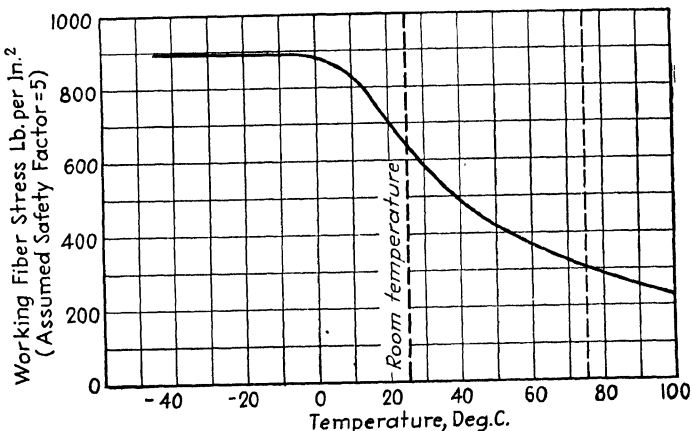

FIG. 91.—Variation of working fiber stress with temperature, Saran tubing B-115.

A representative set of curves for  $\frac{1}{4}$  in. o.d. tubing is shown in Fig. 92. These curves indicate the change in working pressure

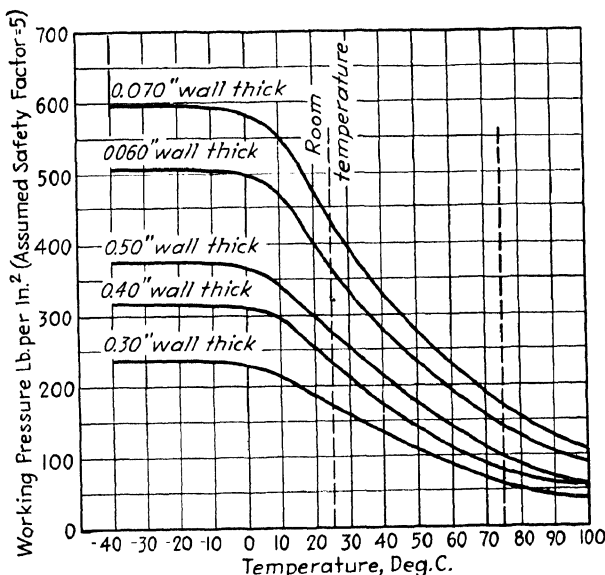

FIG. 92.—Working pressure vs. temperature, Saran tubing B-115,  $\frac{1}{4}$  in. o.d.

not only with temperature but with wall thickness as well. It will be noted that when the temperature is decreased from 100 to 25 deg. C., the working pressure is approximately tripled.

TABLE 30.—BURSTING PRESSURES OF SARAN TUBING\*  
AT 25 DEG. C. (77 DEG. F.)

O.d., in.	Wall thickness, in.	Bursting pressure, lb. per sq. in.	Working pressure, lb. per sq. in., safety factor = 5
$\frac{1}{8}$	0.031	1,900	380
$\frac{3}{16}$	0.031	1,250	250
$\frac{1}{4}$	0.031	900	180
$\frac{1}{4}$	0.045	1,350	270
$\frac{1}{4}$	0.062	1,900	380
$\frac{5}{16}$	0.031	700	120
$\frac{5}{16}$	0.062	1,700	340
$\frac{3}{8}$	0.031	575	115
$\frac{3}{8}$	0.062	1,250	250

\* Courtesy of Dow Chemical Co.

TABLE 31.—CHEMICAL RESISTANCE OF SARAN AT ROOM TEMPERATURE AFTER THREE MONTHS OF CONTINUOUS EXPOSURE\*

Reagent	Stability Rating†
98 per cent (conc.) H <sub>2</sub> SO <sub>4</sub> .....	Good
60 per cent H <sub>2</sub> SO <sub>4</sub> .....	Excellent
30 per cent H <sub>2</sub> SO <sub>4</sub> .....	Excellent
10 per cent H <sub>2</sub> SO <sub>4</sub> .....	Excellent
35 per cent (conc.) HCl.....	Excellent
10 per cent HCl.....	Excellent
65 per cent (conc.) HNO <sub>3</sub> .....	Excellent
10 per cent HNO <sub>3</sub> .....	Excellent
Glacial acetic .....	Excellent
10 per cent acetic .....	Excellent
5 per cent H <sub>2</sub> SO <sub>3</sub> .....	Excellent
Conc. oleic .....	Excellent
50 per cent NaOH .....	Fair
10 per cent NaOH.....	Good
28 per cent NH <sub>3</sub> .....	Unsuitable
10 per cent NH <sub>3</sub> .....	Poor
Ethyl alcohol.....	Excellent
Ethyl acetate.....	Fair
Acetone.....	Fair
Carbon tetrachloride .....	Good
Ethylene dichloride .....	Poor
Di-ethyl ether .....	Poor
Dioxane .....	Unsuitable
Benzene .....	Fair
Ethyl gasoline .....	Excellent
Turpentine .....	Excellent
Butyraldehyde .....	Excellent
Triethanolamine .....	Excellent
Lubricating oil .....	Excellent
Linseed oil .....	Excellent
Bromine water.....	Unsuitable
Chlorine water.....	Unsuitable
Bleaching solution.....	Excellent
10 per cent duponol .....	Excellent
10 per cent zinc hydrosulfite.....	Excellent
15 per cent CaCl <sub>2</sub> .....	Excellent
15 per cent FeSO <sub>4</sub> .....	Good
Water.....	Excellent
Air.....	Excellent

\*Courtesy of Dow Chemical Co.

† These stability ratings are made up on the basis of observations of change in appearance, weight, dimensions, tensile strength, and hardness.

In the same way, when the temperature is decreased from 25 to 0 deg. C. (77 to 32 deg. F.), the working pressure is approximately doubled. At the same time, this change in bursting pressure is accompanied by a corresponding reduction in impact strength.

TABLE 32.—COMPARISON SERVICE CHARACTERISTICS—SARAN AND COPPER\*

Field	Agents	Saran	Copper
Chemical resistance (based on tests for 3 mo. at room temperature)	Acids.....	Excellent	Fair
	Caustic.....	Good	Good
	Bleaching agents...	Excellent	Fair
	Salts.....	Excellent	Fair
	Ammonia.....	Poor	Fair
	Solvents.....	Good †	Good ‡
	Water....	Excellent	Excellent
	Air.....	Excellent	Excellent §
	Oil.....	O.K.	O.K.
Service	Low temperature....	Becomes stiff and brittle	O.K.
	70–170 deg. F . . .	Flexible	Unchanged
	High temperature..	Not over 170 deg. F.	Unchanged
	Flexing.....	Excellent	Limited
	Freezing cycles, closed system .....	Excellent	Limited
	Vibration fatigue....	Excellent	Limited
	Heat conductivity....	Slow	Rapid
	Fluid flow.....		Equal
	Physical state.....	Flexible	Stiff
	Clarity.....	Semitransparent	Opaque

\* Courtesy of Dow Chemical Co.

† Not recommended for certain high oxygen-bearing oxides and some chlorinated aromatic hydrocarbons.

‡ Chlorinated hydrocarbons subject to hydrolysis may be corrosive.

§ Corrosive gases may deteriorate.

Table 30 shows the changes in bursting pressure with changes in cross-sectional area. It will be noted that the operating pressures for most tubing installations are usually within the listed pressure limits.

From Table 32, it will be apparent that Saran should be chosen where chemical resistance, flexibility, and fatigue strength are the more important factors; copper where stiffness and resistance to high temperatures are required. There are, of course, many

applications, such as transfer of air or water, in which the two materials should be equally satisfactory, and other factors, such as ease of fabrication and availability, will regulate the choice.

Saran tubing may be joined by some of the same types of connectors commonly employed with metal tubing. These include flared, compression-welded, and flanged fittings. For the smaller sized tubings that are now available, flared types are very satisfactory. The flaring can be accomplished at room temperature with compression-type flaring tools, or by spinning. If the tubing is cold, it is recommended that the end of the tubing and the flaring tool be heated to room temperature before flaring is attempted. Any necessary trimming may be done with a sharp cutting tool or a file.

The use of a complete Saran system is now possible through the use of flare-type fittings made from injection-molded Saran. These fittings are slight modifications of the standard S.A.E. fitting designs and have the advantage of providing a plastic seal between the tubing and the fitting. This combination eliminates any possible leakage due to unequal thermal expansion of the tubing with metal fittings, provides for a uniform chemical resistance system, and leads to the complete elimination of strategic metals. At the present time, couplings and adaptors as well as elbows and tees are available. As in the case of extruded sections, injection-molded fittings are available from molders equipped to injection-mold Saran.

In bending Saran tubing at room temperature, the tendency to kink decreases with increasing wall thickness. At a wall thickness equal to 20 per cent or more of the diameter of the tubing, it is extremely difficult to kink or collapse. Even in those cases where actual kinking or total collapse occurs, the bursting pressure is reduced no more than 20 per cent. Fabrication, such as bending or forming to permanent desired shapes, is easily accomplished. The tubing is formed at room temperature to the required shape plus allowance for 20 to 30 per cent spring back. It is then heated to approximately 100 deg. C. (212 deg. F.) for 15 to 30 sec. and on cooling will be set to shape. The heating in this procedure may be easily and conveniently obtained with boiling water or atmospheric steam. Without internal support, this tubing can be permanently bent without kinking to a radius as small as three to six times the diameter of the

tubing. Bends can be made to a radius as small as one-half the diameter of the tubing by the use of the same technique, but with the addition of an internal fluid pressure. By this method, it is possible to fabricate many complex shapes, such as elbows, traps, and nozzles, where a permanent set is necessary.

#### APPLICATIONS

This tubing has been adapted to applications such as oil lines for motors, gasoline lines, tubing for recording devices, lead-in pipes for corrosive fluids, atomizer tubes, refrigerant transfer, electrical insulation, sight tubes, humidifier supply lines, air and water lines.

Many of the recent applications of injection-molded vinylidene chloride have been in industrial equipment, replacing strategic materials, such as nickel, aluminum, stainless steel, and rubber. This plastic has been used for spray-gun handles because of its solvent and abrasion resistance, replacing aluminum. Here the practice of cleaning the equipment by washing in potent lacquer solvents does not affect the plastic. In applications such as valve seats, vinylidene chloride is used because of abrasion resistance, resilience, and resistance to corrosive gases and liquids. Typical moldings for the rayon industry include spinnerette couplings, gasket holders, filter parts, nozzle tips, rollers, guides. Here the inertness of the plastic and its stability to chemicals and solvents are taken advantage of in replacing special formulations of hard rubber.



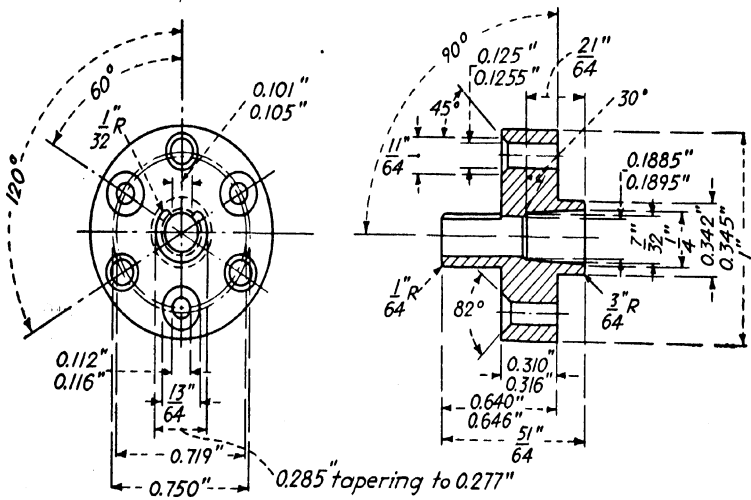

FIG. 93b.—Fractional line-spacer cylinder end, also of cellulose acetate. (Courtesy of Royal Typewriter Company, Inc.)

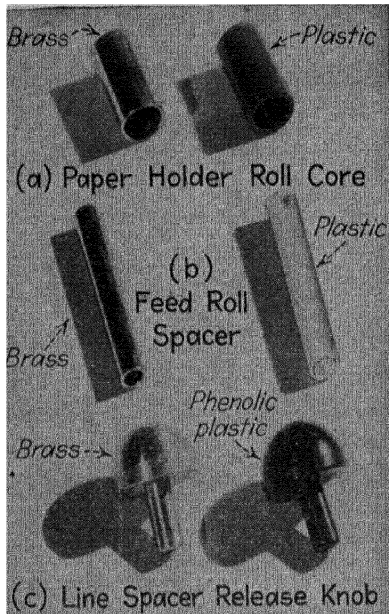

FIG. 93c.—Redesigned typewriter parts, now cellulose acetate.

cemented together to make a bond as strong as the material itself.

Hardness can be varied within limits, but, in general, it is comparable with that of hard rubber, aluminum, or hard oak wood.



FIG. 93d.—Cellulose acetate plastic replaces porous bronze bushing in new Royal typewriter design.

Cellulose acetate is unaffected by ordinary temperatures. In the more usual formulas and flows, it shows some softening on exposure to temperatures of 140 deg. F. or higher. Its thermal conductivity is low, being comparable with that of wood. It supports combustion with difficulty, burning like hard rubber, fiber wood, or similar substances.

Cellulose acetate is not damaged by contact with most vegetable and mineral oils. Alcohols and some essential oils of an aromatic nature will spot the surface of a molded piece. Acetates should not be subjected to concentrated acids or alkalis.

All cellulose ester molding compositions are somewhat hygroscopic and will absorb moisture to some extent, depending upon the relative humidity and temperature as well as the formula used.

Many variations can be made in formulas in order to accentuate the physical properties desired for particular products. Table 33 gives the range of properties in the formulas and flows regularly supplied. Such all-inclusive figures necessarily show rather wide limits, and it should be understood that no one formula can have every quality in the same high degree.

TABLE 33.—PROPERTIES OF CELLULOSE ACETATE MOLDING COMPOSITION

Specific gravity.....	1 3-1 37
Specific volume, cu. in. per lb.....	21 8-20. 2
Tensile strength, lb. per sq. in.....	2,800-10,000
Compressive strength, lb. per sq. in.....	7,000-26,000
Flexural strength, lb. per sq. in.....	4,000-18,000
Modulus of elasticity, lb. per sq. in.....	$2.0-3.5 \times 10^5$
Impact strength, ft.-lb. per in. of notch, $\frac{1}{2}$ - by $\frac{1}{2}$ -in.	
bar, Izod.....	0.7-4 2
Thermal conductivity, cal./(sec.)(sq. in.)(deg. C.)(in.)	$4 5-7.8 \times 10^{-4}$
Thermal expansion per deg. C.....	$8-16 \times 10^{-5}$
Softening point, deg. F.....	145-260
Distortion under heat, deg. F.....	105-215
Dielectric strength,* short-time volts per mil, $\frac{1}{8}$ in. thickness.....	350-900
Dielectric constant:*	
60 cycles, 50 per cent relative humidity.....	3.5-6.4
1,000 cycles, 50 per cent relative humidity.....	3 5-6 4
1,000,000 cycles, 50 per cent relative humidity.....	3.2-6.2
Power factor:*	
60 cycles, 50 per cent relative humidity.....	0.01-0.06
1,000 cycles, 50 per cent relative humidity.....	0.01-0.06
1,000,000 cycles, 50 per cent relative humidity.....	0.01-0.05
Water absorption, per cent, 24 hr.....	1.3-3.8

\* Tests run on specimens  $\frac{1}{8}$  in. in thickness.

### CELLULOSE ACETATE-BUTYRATE PLASTICS

This relatively new plastic is a first cousin of the acetates, made in a similar manner but involving the use of both butyric and acetic acids. The molding compositions obtained are similar in behavior to the acetates, except that the butyrates have lower moisture absorption.

In general, cellulose acetate-butyrate has greater dimensional stability, or resistance to distortion under varying conditions of temperature and humidity than cellulose acetate. This is due in part to the lower sorptive nature of cellulose acetate-butyrate plastic, which absorbs upon immersion about the same amount of water as nitrocellulose plastic, or about half as much as cellu-

lose acetate plastic. An additional reason is that cellulose acetate-butyrate plastic requires considerably less plasticizer for a given flow. The smaller the quantity of plasticizer used, the better it is retained in the plastic. With cellulose acetate-butyrate plastic, it is possible to use plasticizers that are of higher

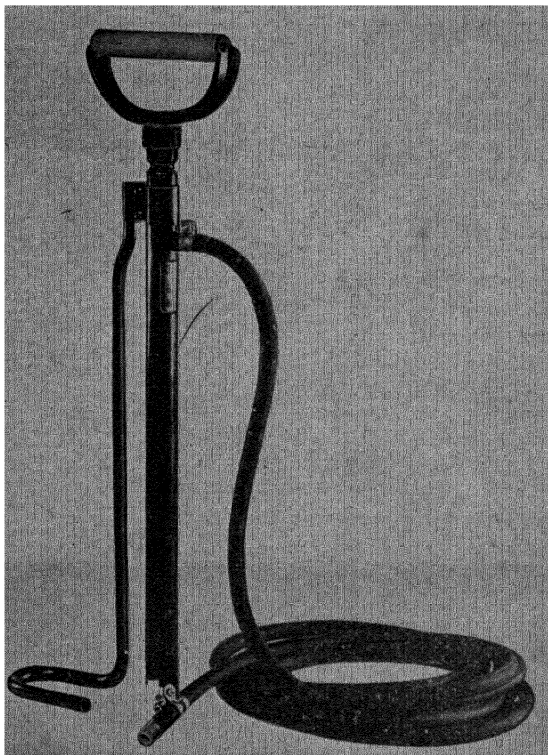

FIG. 94a.—Cellulose acetate-butyrate and vinyl plastic replace brass and rubber in this new stirrup pump.

boiling point, lower vapor pressure, and have greater compatibility with the ester than those available for use with cellulose acetate plastic. These factors give the cellulose acetate-butyrate plastic greater dimensional stability.

The specific gravity of cellulose acetate is approximately 1.3; that of cellulose acetate-butyrate, approximately 1.2. Products made of butyrate are, therefore, somewhat lighter; or, from a given number of pounds of plastic, the number of molded pieces

obtained is more than 6 per cent greater. A higher mold finish is obtainable.

Cellulose acetate-butyrate is recommended over cellulose acetate for continuous extrusion because of its lower moisture absorption and lower plasticizer content. The former tends to minimize any bubbles and the latter any smudge due to condensation of plasticizer on the strip, rod, or tube as it is extruded.

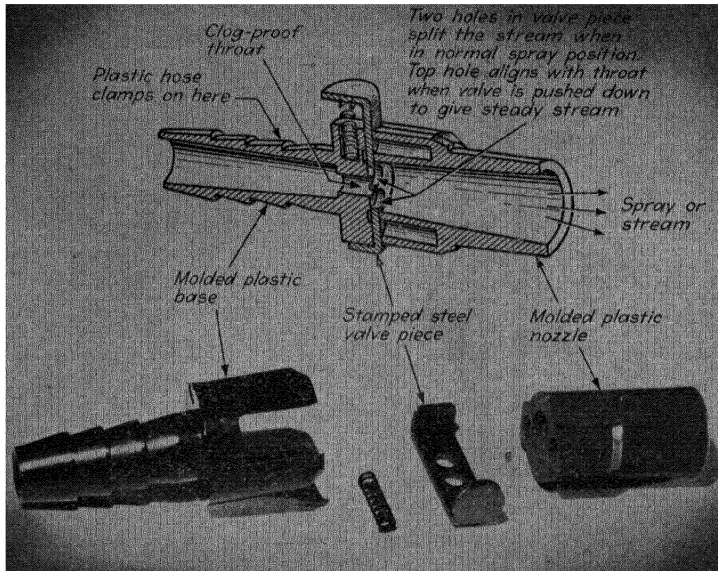

Fig. 94b.—Nozzle for stirrup pump consists of two cellulose acetate-butyrate parts cemented together with acetone.

To secure best results, it is essential that the material be dried immediately prior to molding.

### COLOR

Colors available include the entire range of the spectrum. They may be had in any degree of transparency, from crystal clear to opaque or in variegations (mixed colors). Where variegated effects are to be produced by injection molding, the granulation should be ordered in plain colors for mixing, as needed. The molder can easily control the variegation by adjusting the relative quantities of the components. The configuration

of these colors in the finished article is the result of blending that occurs during the molding process. Blending is influenced by the size of the piece and by the size of the nozzle, sprue, runners, and gate as well as by molding temperature. It is also influenced by the relative degrees of hardness of the component colors and by their particle size; the predominant color or base is usually

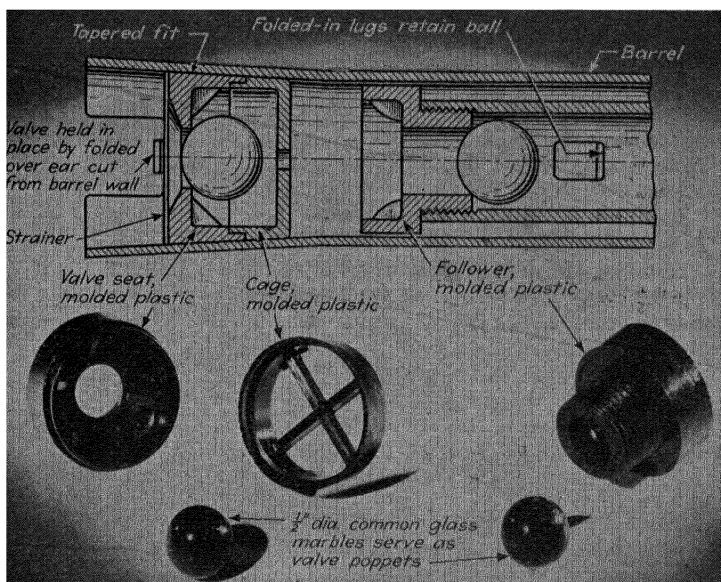

FIG. 94c.—Valve seats and cage for stirrup pump are also molded of cellulose acetate-butyrate.

furnished in a much softer flow, and sometimes in a different particle size, than the other colors, which are known as “fillers.” When transparent or translucent colors are used, the density of the color relative to the section thickness of the molded piece is an important consideration.

### EXTRUDED PLASTICS

Although not new, the extrusion process has undergone considerable development recently. Shapes in almost any length, ranging from flat strips, rods, tubes to pieces of various cross sections, are now available.

Almost any thermoplastic can be extruded provided proper equipment and technique are employed, but to date the principal

TABLE 34.—PROPERTIES OF CELLULOSE ACETATE-BUTYRATE

Specific gravity.....	1.14-1.22
Specific volume, cu. in. per lb.....	24.3-22.8
Tensile strength, lb. per sq. in.....	2,500-7,500
Compressive strength, lb. per sq. in.....	7,500-22,000
Flexural strength, lb. per sq. in.....	2,800-13,000
Modulus of elasticity, lb. per sq. in.....	$2.0-3.5 \times 10^6$
Impact strength, ft.-lb. per in. of notch, $\frac{1}{2}$ -in. by $\frac{1}{2}$ -in. bar, Izod.....	0 8-5 5
Thermal conductivity, cal./(sec.)(sq. in.)(deg. C.) (in.).....	$4.5-7.8 \times 10^{-4}$
Thermal expansion per deg. C.....	$11-16 \times 10^{-5}$
Softening point, deg. F.....	140-250
Distortion under head, deg. F.....	115-215
Dielectric strength,* short-time volts per mil, $\frac{1}{8}$ in. thickness, 50 per cent relative humidity.....	250-400
Dielectric constant:* *	
60 cycles, 50 per cent relative humidity.....	3.5-6.4
1,000 cycles, 50 per cent relative humidity.....	3.5-6.4
1,000,000 cycles, 50 per cent relative humidity.....	3 2-6 2
Power factor:*	
60 cycles, 50 per cent relative humidity.....	0.01-0.06
1,000 cycles, 50 per cent relative humidity.....	0 01-0.06
1,000,000 cycles, 50 per cent relative humidity.....	0 01-0.55
Water absorption, per cent, 24 hr.....	1.2-2.0

\* Tests run on specimens  $\frac{1}{8}$  in. in thickness.

materials extruded are cellulose acetate,<sup>g</sup> cellulose acetate-butyrate, ethyl cellulose, vinylidene chloride, and vinyl acetate. Choice of material depends on equipment, service factors, and cost.

With cellulose acetate it is possible to extrude strips from which blanks can be immediately stamped for subsequent swaging or fabrication as required. The particular advantage of the procedure is that the scrap from the strips can be granulated and fed again into the hopper of the extrusion machine, making the utility value of the material substantially 100 per cent. Scrap from purchased plastic sheeting, on the other hand, has a market value representing only a fraction of the original cost.

Best results in extrusion are obtained with relatively hard-flowing material; the harder the flow the quicker the setup. The hardness of flow and the effectiveness of the cooling device will determine the concentricity of the extruded plastic tubing.

Extruded shapes often have tracks of channel shape or C shape to receive other parts. Rolled metal strips are sometimes

applied after extruding to add strength and stiffness, to provide fastening means, or to prevent warpage of the part in service.

Tracks can be on the exposed side of the strip to receive plated or polished metal or extruded plastic strips in a contrasting color. A great variety of combinations can be secured in this way. Another and promising application is the use of extruded plastic inserted in slots formed in rolled or extruded metal sections. The extruded plastic, being flexible, can be bent or shaped to various contours.

Fastening is done in various ways. In one type, a metal strip is held in an integral track on the back of the extruded plastic. The metal is punched to form prongs. Corresponding holes in the panel receive the prongs. An alternative is to provide threaded studs with flat elongated heads that fit the track. The studs can be slid along to conform to hole spacing. The elongated head prevents the stud from turning in the track. If the back of the panel is not accessible or a snap fastening is desired, spring clips made from wire are used in place of threaded studs. These clips spring outward after passing through the holes. They can be obtained in shapes that make possible the removal of the extruded strip when the back of the panel is not accessible.

All plastic extrusions have a smooth surface with a high polish, precisely as if produced in a polished mold. Extrusions can be supplied cut to length or in continuous coils. Flat or slightly crowned strips supplied in rolls can be woven into highly decorative panels, chair seats, back rests, pedestal coverings, and the like in one or more colors.

Thin, narrow extrusions can be coiled around tubes or rods to give ropelike effects in one or more colors. Helical coils of this type are used on flexible insulated wires, such as telephone receiver leads, to prevent kinking and to protect against abrasion. Similar coils are useful over flexible or stiff tubing of metal, paper, and the like, or over rods of any material in circular or other sections. If the plastic coil is transparent or translucent, the polished core shows through the plastic and adds sparkle and beauty to the assembly.

Extruded tubes have been recently used for a  $\frac{3}{8}$ -in. o.d. aircraft conduit. Since the tubing is transparent, the wires can be seen. The tube acts as an insulator and is easily bent for

assembly and light in weight. In another application, transparent tubing is used in place of glass for soda syphons in bottles.

Another extruded product used for coil forms has a circular hole 0.015 in. in diameter and a three-point star-shaped exterior. One end of the coil wire is brought through the central hole and the remainder of the wire is wound on the edges or points of the star-shaped strip. Extruded plastic has also been applied over a wire central core, as is done in rubber-covered wire. In one case the material is opaque white to match the enamel of a refrigerator shell. The extrusion hides the joint between two curved sheet-steel panels. After a length is pulled taut around the recess, the wire ends are bent inward to form hooks that hold the strip in place. Extruded T shapes or others can be applied to hide joints in any panel assembly or to provide finished edges or decorations on many products where, heretofore, metal or wooden moldings usually have been applied.

Although extrusion requires the use of a die, such a die costs only a small fraction as much as does a mold for shaping plastic by press molding. Die cost depends on the size and shape of section to be extruded and has ranged from \$30 to \$125 for most extrusions produced up to the present time.

## CHAPTER XV

### ETHYL CELLULOSE

Ethyl cellulose is basically an ether of cellulose with ethyl alcohol. It is chemically distinct from other cellulose plastics such as cellulose nitrate, cellulose acetate, and cellulose acetate-butyrate, which are esters of cellulose. The chemical stability of ether compounds is shown by the compound's stability to hydrolysis or to chemical breakdown. It is resistant to dilute acids, to concentrated and dilute alkalies, and to heat.

The outstanding properties of ethyl cellulose are toughness and strength, low-temperature shock resistance, retention of original properties on aging or on exposure to a wide range of temperature-humidity conditions. It also possesses dimensional stability, water resistance, and heat resistance. Other characteristics are lightness of weight and good insulating properties. Molding compounds are available in a standard range of flow grades and colors, in types for injection molding, for compression molding, for extruding shapes, and for extrusion wire coating.

Ethyl cellulose under the trade name of Ethocel is available in the following types:

1. Injection regular for general injection-molding use. It flows readily in the mold, releases easily, and yields moldings free from shrinkage voids or sinks even in heavy sections. Moldings have low water absorption, good impact and tensile strength, especially at subzero temperatures, and these properties are combined with good dimensional stability, good heat resistance, excellent weld strength, good surface hardness, and high gloss. This type is available in varying degrees of flow.

2. Compression regular for most compression-molding applications. It possesses the same combination of properties as the injection formula and is particularly adapted to molding over metal inserts where low temperature, shock resistance, and resistance to moisture changes are required.

3. Extrusion regular for fabricating extruded shapes. It is useful for a wide variety of applications ranging from those which require softness, flexibility, and toughness to those requiring rigidity, heat resistance, and good resistance to shock.

4. Extrusion wire coating developed for extruding a complete plastic insulation on bare wire in a single operation. It has high flexibility, particularly at subzero temperatures, is tough, strong, and has a high degree of moisture resistance, excellent electrical properties, and good adhesion to the wire.

#### CEMENTING

Molded ethyl cellulose can be cemented either to itself or to cloth, paper, wood, or felt with a strong permanent bond. The surfaces to be joined should be as smooth as possible to provide maximum contact area. They should be free of grease and dirt. Adhesives may be applied by brushing, by running the adhesive from an oilcan with a pinhole nozzle onto the joint, by touching the surface to be cemented to a felt placed in a shallow dish containing the cementing material, or by any of the other standard methods normally employed. Since these adhesives may contain flammable solvents, they should be kept away from open flames. The surfaces should be joined immediately after the adhesive is applied and preferably should be kept under a slight pressure until the adhesive has set, by clamping devices or with weights.

#### MARKING

For recessed or depressed letters, numerals and other designs are molded into the surface of the piece. Wipe-in paints that possess good adherence, gloss, and moisture resistance are available. These paints must be carefully selected with due regard for their solvent action on the plastic, since they must adhere to the depressed areas but also must be capable of being wiped clean from adjacent surfaces with which they will come in contact during the operation. Wipe-in paints are applied simply by brushing over the recesses and wiping off the excess with a soft paper or cloth. Some molders apply the paint with a large hypodermic needle and are thus able to fill the recesses accurately with a minimum of cleaning. Others use air brushing to advantage.

## INLAYS

Colored plastics or metal foils can be imbedded permanently in the surface of the ethyl cellulose by laying a piece of foil or metallic leaf over the area that is to be decorated and pressing it into place with a hot die. A jig designed to hold the part in the correct position in relation to the stamping die is recom-

TABLE 35.—PROPERTIES OF ETHYL CELLULOSE\*

Injection grades	
Specific gravity, 70 deg. F. ....	1.15
Mold shrinkage, in. per in. ....	0.002
Specific heat, cal./(g.)(deg. C.):	
At 21 deg. C. (70 deg. F.) .....	0.3
At 149 deg. C. (300 deg. F.).....	0.55
Distortion temperature, deg. F.....	158-187
Heat shrinkage, in. per inch, 70 to 170 deg. F.:	
24 hr. ....	0.004-0.007
7 days.....	0.005-0.009
Cold shrinkage, in. per in., 70 to -40 deg. F. ....	0.001-0.002
Tensile strength, lb. per sq. in. ....	6,000-9,000
Elongation, per cent. ....	4.7-9.5
Impact strength, (Izod) ft.-lb. per in. of notch.....	7.4-8.2
Rockwell hardness (superficial), 1/2-in. ball, 15 kg. load.....	74-85
Water absorption, 24 hr. immersion at 70 deg. F., per cent by weight .....	1.3-1.5
Material extractable by water in above test.....	None
Dielectric strength, volts per mil at 0.010 in. ....	1,400-1,700
Power factor:	
1,000 cycles, per cent. ....	2.24-3.80
1,000,000 cycles, per cent.....	2.10-2.90
Dielectric constant:	
1,000 cycles .....	3.67-3.98
1,000,000 cycles .....	3.20-3.50
Extrusion grades	
Extrusion temperature, deg. F. ....	340-360
Specific gravity, 70 deg. F. ....	1.16-1.18
Tensile strength, lb. per sq. in. ....	2,500-4,500
Yield point, lb. per sq. in. ....	1,500-3,500
Elongation, per cent. ....	45-85
Rockwell hardness (superficial), 1/2-in. ball, 15 kg. load.....	46-86
Wet strength, lb. per sq. in. ....	2,200-4,000
Water absorption, 24 hr. immersion at 70 deg. F., per cent by weight.....	1.1-1.5
Burning rate (A.S.T.M.) in. per min.....	0.9-1.2
Dielectric strength, volts per mil at 0.010 in.....	2,000

\* Courtesy of Dow Chemical Co.

mended. The die is usually placed in position in a hand or kick press for production work.

#### CONTAMINATION

Ethyl cellulose is not compatible with other thermoplastic molding materials and must therefore be kept free from contamination if the scrap is to be used. Contamination is indicated if the molded piece shows lamination, pearlescence, or sticking to the mold surfaces. Injection machine cylinders and extrusion machines should always be cleaned out thoroughly.

#### EFFECT OF MOISTURE

Although moisture absorption is exceptionally low, long exposure to high humidities may result in enough moisture being absorbed to cause imperfections during extrusion or on injection molding of heavy sectioned pieces. Predrying is indicated when injection moldings show flecked surfaces, when extruded sections have rough or pebbly surfaces, or when compression molded pieces contain bubbles or show imperfect surface.

## CHAPTER XVI

### LAMINATED PLASTICS

#### MANUFACTURE

Produced through the reaction of pressure and heat upon plies or layers of paper sheets or fabric that have been impregnated with heat-hardening varnish, laminated phenolic materials because of their hardness, water and heat resistance, mechanical and dielectric strength, and chemical inertness are being used for many parts that were formerly made of steel, iron, aluminum, brass, bronze, lead, wood, rubber, glass, asbestos, porcelain, leather, or paper.

#### GRADES AVAILABLE

Properties of laminated phenolic resin materials are primarily dependent on type of filler material, the phenolic resin that serves principally as the binder, and the time and temperature of cure. The filler material may be cotton fabric, paper, asbestos, or glass fabric. The laminated phenolic with a fabric or paper base may be combined with natural rubber or synthetic rubberlike materials, such as Thiokol, Neoprene, or Corprene. The resin may be impregnated with other material, such as graphite, in order to obtain certain desired properties, or the impregnated filler sheet may be partly cured, macerated, and molded to shape.

Of the two most common types of laminated phenolic, the fabric-base grade is usually suitable where good mechanical properties, such as impact strength or resistance to shock, are required, and where electrical requirements are of secondary importance. The paper-base grades are suitable for applications where electrical properties are important considerations and where mechanical properties, such as strength and impact, resistance are secondary.

In addition to these two general grades of paper- and fabric-laminated, the resin may be laminated with asbestos-paper base or asbestos-fabric base for particular applications in which

strong alkaline conditions are encountered or for exposure to chemical salts in high concentration. A comparatively recent development, woven glass-cloth laminated, has excellent resistance to strong concentrated acids including chromic and strong sulphuric acids.

Combination materials utilize rubber, Neoprene, Corprene, Thiokol, or vulcanized fiber, thus combining physical properties,

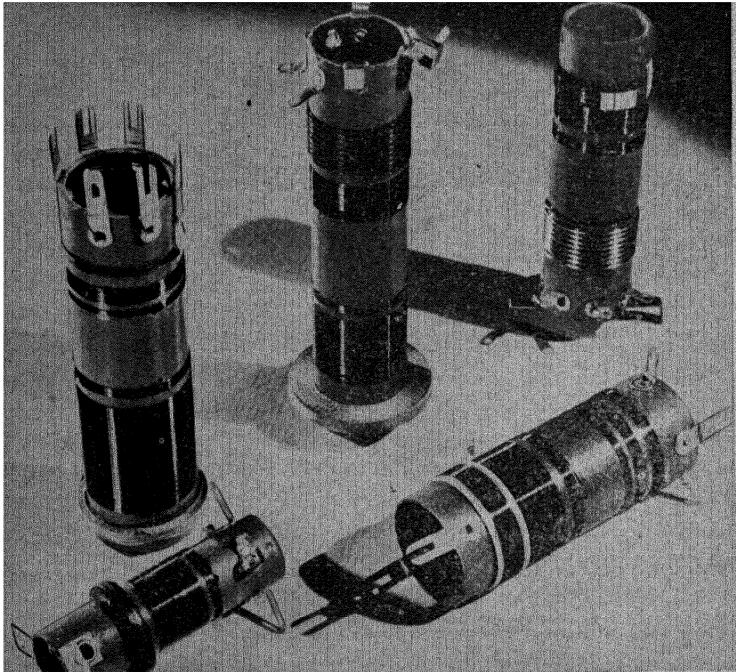

FIG. 95.—Radio-coil forms are a typical application of laminated plastic tubing.

such as the resilience of rubber and Corprene, the oil-resisting ability of Neoprene and Thiokol, and the arc-resisting or arc-damping quality of vulcanized fiber with the machinability and strength of the laminated phenolic.

In graphite-impregnated laminated, the graphite acts as a lubricant, thereby reducing the coefficient of friction and minimizing temperature rise and frictional power losses. Other special materials include molded-laminated and molded-macerated

grades. In the molded-laminated types, pieces of impregnated paper or fabric are cut to the required dimensions to fit a mold and are then cured under heat and pressure. In molded-macerated materials, impregnated paper or fabric is shredded to small pieces, which are then cured in a mold under heat and pressure. Either of these methods may show considerable cost savings over machining methods if sufficient quantities are involved to warrant the expense of molds. However, molded-macerated materials are generally somewhat weaker mechanically than the corresponding laminated sheet.

The nomenclature of the various types commercially available has been standardized by N.E.M.A. and descriptions of their inherent characteristics are included in the N.E.M.A. standards.

There are three general classes of paper-base stock, grades *X*, *XX*, and *XXX*. On the punching stock grades, the letter *P* follows the grade classification. These grades have suitable plasticizers added to the impregnating resin to soften the sheet and make good punching possible. Of course it is possible to punch the nonplasticized paper base grades by preheating the material in some cases. Moisture resistance, dimensional stability, and good electrical properties increase with the number of *X*'s.

For mechanical applications where good electrical properties are of secondary importance, grade *X* is recommended. However, if good electrical properties are required even under conditions of high humidity and where high mechanical and impact strength is of secondary importance, then grades *XX* and *XXX* are recommended.

For high-impact applications and particularly where electrical considerations do not prevail, fabric-base laminated is recommended. These grades are known as *C*, *CE*, *L*, and *LE*. The laminations in the *C* grades are heavy-weave fabrics, 6 to 16 oz. per sq. yd. as a base; the *L* grades have fine-weave fabrics, 3 to 4 oz. per sq. yd. as a base. The finer weave cloths show practically as good mechanical strength as the heavier ones except that impact strength is somewhat lower. The fine weave cloth, although somewhat higher in price, is preferred in applications where a fine machined appearance and clean cuts are desirable, as in fine tooth gears or breaker arms. For better electrical properties where impact is a factor, grades *CE* and *LE* are recom-

mended in preference to paper-base laminated; these are identical to the *C* and *L* grades, except that the impregnated fabric has been further processed to improve electrical qualities of the finished sheet. However, they have generally poor impact strength and a slightly lower tensile and transverse strength than the corresponding *C* and *L* grades.

Where heat resistance and resistance to moisture absorption are factors, asbestos-base laminated, grade *A* or *AA*, may be

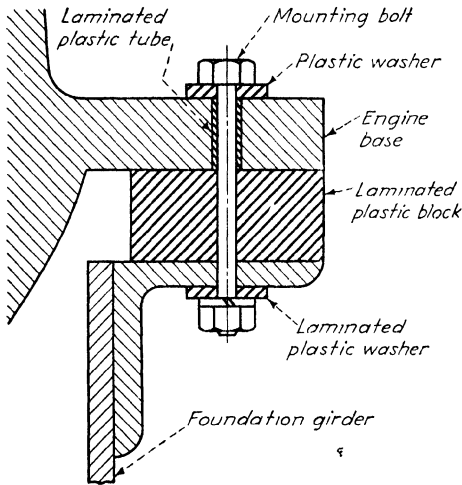

FIG. 96.—Resilient mounting for diesels. Forty blocks of laminated plastic support a 60-diesel engine in a recent installation.

used. These materials are more resistant to flame and slightly more resistant to heat than other laminated grades because of high inorganic content. Where these same qualities are desired but more mechanical strength is necessary, grade *AA* can be used. Electrical properties of these two grades are poor and machining is difficult. However, both have good moisture resistance and dimensional stability under high humidity conditions. Immersion in water for a period of six months to a year has shown a water absorption of not more than 3 to 5 per cent.

The safe operating temperature of laminated plastic depends upon the grade selected and whether the material is to be subjected intermittently or continuously to the specified temperature. Generally speaking, 225 deg. F. is the maximum safe continuous operating temperature for any of the usual grades;

250 deg. F. is the limit for intermittent application: The asbestos-base grades may be used at somewhat higher temperature and, by special processing during manufacture, this material will withstand intermittent temperatures up to 400 deg. F.

For structural members, or electrical insulating parts under dielectric stress, a factor of safety of 4 is recommended for mechanical strength and 6 for dielectric strength.

TABLE 36.—COMPARATIVE PROPERTIES OF GLASS-FABRIC LAMINATED AND GRADE CE FABRIC LAMINATED  
Specimens  $\frac{1}{8}$  in. thick

Properties	Glass base	Grade CE
Dielectric strength (short-time test), volts per mil.....	396	325
Power factor at 1,000,000 cycles	0.011	0.055
Dielectric constant at 1,000,000 cycles	4.4	5.5
Loss factor at 1,000,000 cycles.....	0.048	0.30
Power factor at 1,000,000 cycles after 24 hr. in water.....	0.015	0.075
Tensile strength, lb. per sq. in. (depends on fabric).....	6,000–15,000	8,000–11,000
Transverse strength, lb. per sq. in. (depends on fabric).....	15,000–25,000	17,000–22,000
Compressive strength, lb. per sq. in. ....	49,000	36,000
Izod impact strength, ft.-lb. per in. of notch	10	6.7
Cold flow (after stabilized) per cent.....	0.20	0.5–1.0
24-hr. water absorption, per cent.....	1.2–2.3	0.50–1.2
Specific gravity.....	1.55–1.60	1.35
Rockwell hardness.....	110–115	105–110
Surface leakage resistance after 7 days at 90–95 per cent humidity, megohms.....	5	100

The combination of laminated phenolic and rubber, bonded together under heat and pressure, is an interesting application in the uniting of two different materials having different characteristics. Rubber is naturally resilient, whereas the laminated plastic is tough and strong and has good impact strength. Paper- or fabric-base plastic may be laminated with rubber from  $\frac{1}{64}$  up to  $\frac{1}{2}$  in. or more in thickness. The combinations are rubber one side; rubber both sides; plastic both sides, rubber between; alternate layers.

Rubber generally used is equivalent to packing rubber containing 0.6 per cent free sulphur. Where oil resistance is important, special rubber or synthetic rubber can be used. In a typical application, such as electrolytic and oil-type condensers, the combination washers have rubber on one side and laminated plastic on the other. The plastic supplies mechanical strength and protects the rubber from corrosive action of the chemicals. In another, a round-headed machine screw with a cork washer passes through a hole in the wall from the inside. A rubber-plastic washer then goes on from the outside with the rubber next to the wall. The laminated plastic on the outside offers a firm base for seating the nut.

Glass-fabric-base material is primarily suitable for certain mechanical and chemical applications. Its electrical properties are not stable. It is not recommended where excellent electrical properties are required, although it may be used in cases where the requirements are not severe.

Although mechanical strength is 10 to 20 per cent better than that of cotton-fabric-base material, this is hardly enough to warrant the additional cost except for special applications. There is, however, a 50 per cent improvement in impact strength and considerable improvement in resistance to cold flow.

Probably the largest present use for this glass-base material is in chemical applications since glass is practically immune to attack by most acids except hydrofluoric acid. This is not generally true of cellulose-base materials. Glass base is not recommended for any applications involving alkali-base materials as glass is attacked by most alkalies. Glass base is easily attacked by alkalies in all concentrations but is the most resistant material against acids. Even chromic acid and strong sulfuric have little effect on glass-laminated.

Disks of graphitized laminated material under test were held in a lathe and a steel disk was then pressed against the surface of test materials with a uniform load of 20 lb. at 525 r.p.m. and with a uniform load of 80 lb. at speed of 154 r.p.m. The differential increase in the watts consumed is listed in Table 37 for the different grades under two different conditions. The watts representing the power consumption are a guide to the improvement to be obtained with grade *C-YB*, since the power consumed is proportional to frictional load and indicates two

things: the wear likely to be experienced and the amount of heat generated by the friction.

TABLE 37.—TEST RESULTS ON GRAPHITIZED LAMINATED  
Watts consumed when steel disk was pressed against rotating specimen  
disk held in lathe

Grade	Watts consumed with uniform load on steel disk	
	20 lb. at 525 r.p.m.	80 lb. at 154 r.p.m.
<i>C-YB</i> (Synthane) . . . . .	145	95
<i>L</i> . . . . .	185	130
<i>C</i> . . . . .	185	135
<i>A</i> . . . . .	185	120
<i>AA</i> . . . . .	205	105
<i>XX</i> black . . . . .	235	160
<i>XX</i> natural . . . . .	265	135

General rules cannot be made for performance of standard types when exposed to various chemicals, since individual conditions vary widely. Impurities or associated materials, in themselves harmless to synthetic resins, very often cause a breakdown, which otherwise might not occur. A good example of this is carbon tetrachloride, which alone is a good, stable solvent for many organic substances. This is not so when solutions of certain organic materials in carbon tetrachloride are exposed to a low heat of 120 deg. F., oxygen of the air, moisture as low as 0.1 per cent, and metals, such as iron or zinc from the container. Under these conditions the mixtures of carbon tetrachloride and various metallic chlorides are corrosive and attack resins.

In view of the foregoing it is difficult to generalize, but in the selection of a laminated sheet for a chemical application the choice of the base fabric or paper is most important, as it is usual that the chemical will first destroy the base. Cellulose paper should be avoided in all cases as the structure of paper is inherently poor for good impregnation. Also, water absorption is comparatively high and is directly proportional to the chemical resistance.

Cellulose cloth should be selected for uses where weak acids, weak bases, and solutions of various salts are encountered.

TABLE 38.—LAMINATED PHENOLIC PAPER-BASE TUBING—STANDARD PROPERTIES

Tests made on 1- by 1 $\frac{1}{8}$ -in. tubing; based on N.E.M.A. Standards

	Grade X rolled	Grade XX rolled	Grade X molded	Grade XX molded
Minimum Standards				
Density, grams per cc . . . . .	1.10	1.10	1.25	1.25
Tensile strength, lb. per sq. in . . . . .	7,500	7,000	9,000	7,500
Compressive strength, axial, lb. per sq. in. . . . .	10,000	12,000	15,000	15,000
Dielectric strength, volts per mil:				
Short time . . . . .	500*	400	400	300
Step by step . . . . .	300	250	250	200
Maximum Standards				
Water absorption, percentage by weight, 1 in. length, 24 hr. at 25 deg. C. $\pm$ 2 deg. C. . . . .	5 0	2 5	4 0	2 0
As received condition:				
Power factor . . . . .	0 040	0 040	0 045	0 040
Dielectric constant . . . . .	5.0	5 0	6 0	5 5
Dielectric loss factor (at 1,000,000 cycles) . . . . .	0.20	0 20	0 26	0 22
After 24-hr. immersion in water at 25 deg. C.				
Power factor . . . . .	0.070	0.055	0 070	0.055
Dielectric constant . . . . .	6.0	6.0	7.5	6.5
Dielectric loss factor (at 1,000,000 cycles) . . . . .	0.42	0.33	0.52	0.35

\* The high dielectric strength of grade X rolled tubing is true only under dry conditions. Under high humidity its dielectric strength is low.

Generally speaking, it has better resistance than the other two base materials, which are higher in price.

Asbestos should be used only when strong alkaline conditions are encountered or when exposed to salts in high concentration

which tend to hydrolyze or split to alkaline radicals. Asbestos, being alkaline, is easily attacked by acids and salts.

TABLE 39.—ELECTRICAL PROPERTIES OF LAMINATED PLASTICS

N.E.M.A. grade of phenolic laminate	Power factor at 1,000,000 cycles per sec.	Dielectric constant at 1,000,000 cycles per sec.	Dielectric strength, volts per mil		Water absorption, 24-hr. immersion, per cent by weight (sample, 3 by 1 by $\frac{1}{16}$ in.)
			Short time	Step by step	
X	.....	.....	700	500	4.0
P	.....	.....	700	500	3.0
XX	0.040 (0.062*)	5.0 (4.3*)	700	500	1.3
XXP	0.040	5.0	700	500	1.3
XXX	0.032	4.8	650	450	1.0
XXXP	0.027 (0.045*)	4.5 (3.8*)	650	450	1.0
C	0.10	7.0	200	120	3.0
CE	0.055 (0.055*)	5.5 (4.0*)	500	300	1.5
L	0.10	7.0	200	120	2.0
LE	0.045	5.0	500	300	1.2

\* At 100,000,000 cycles per second.

The following properties are for Dilectene 100, made by the Continental Diamond Fibre Company. Samples were  $\frac{1}{8}$  in. thick.

Power factor at 100 cycles per second	0.0023
1,000 cycles per sec.	0.0035
1,000,000 cycles per sec.	0.0062
100,000,000 cycles per sec.	0.0032
Dielectric constant at 100 cycles per sec.	3.7
1,000 cycles per sec.	3.7
1,000,000 cycles per sec.	3.6
100,000,000 cycles per sec.	3.6
Dielectric strength, volts per mil:	
Short time	640
Step by step	410
Water absorption, 24-hr. immersion, per cent by weight, sample 3 by 1 by $\frac{1}{8}$ in.	0.08

LAMINATED PHENOLIC CAMS

From the results of an investigation of laminated phenolic cams made by the research division of the United Shoe Machinery

Corporation, and reported in *Product Engineering*, the following facts were determined:

Surface endurance limits of laminated phenolic materials vary for materials from different manufacturers. For that reason and because of the lack of more information, wear factors cannot be given.

Phenolic materials differ from metals in that speed affects the surface endurance limit. The greater the speed the smaller their endurance limits. Some laminated phenolics are superior to others because of variation in the elastic deformation, internal friction, and heat conductivity.

Failure at high speeds is mainly the result of excessive internal heat or friction in the material and generally causes the appearance of blisters or a darkened surface layer. At lower speeds the internal heat of friction is not the cause of failure, but surface wear occurs solely because of excessive stresses set up in the material.

Surface wear resistance of laminated phenolic materials compares favorably with that of good cast iron.

From the results of test experience with nonmetallic gears, and studies of cam motions, it was found that laminated phenolic materials used for cams have the following advantages:

1. They tend to absorb vibrations and deaden noise set up by the contact of the cam surface and the mating roll. As with tooth surfaces of laminated phenolic gears, the influence of the irregularities of the cam surface is minimized.

2. They reduce impact loads between cam and roll at crossover of the cam because of the greater deformation of the cam surface during impact. Other things being equal, a laminated phenolic surface will deform many times more under compression than a steel surface.

3. They have good resistance to surface wear, comparing favorably with a good grade of cast iron. When speed is not excessive, the surface endurance limit is sometimes greater than that of cast iron.

4. They decrease the influence of inertia on cam shafts operating at variable speed and starting and stopping frequently.

Since accelerations and decelerations introduce inertia loads that result in greater stresses in the driving parts and increased loads on the supporting bearings, reduction of the rotating mass gives smoother operation and longer life.

5. They are easily balanced. Since laminated phenolic materials are about one-fifth to one-sixth the weight of steel, balancing of the cams is considerably easier.

6. They can be molded and thus reduce machining costs. A serious objection to the use of nonmetallic materials for cams is the cost of the material. In cooperation with one of the leading manufacturers, cam molding has been attempted and has proved to be successful. Machining costs are reduced enough almost to offset the greater cost of material.

#### EFFECTS OF GRAPHITE

In using phenolics for cams, it has been found that those containing 5 to 7 per cent of graphite are most suitable. When operating at low speed, the presence of graphite ensures lubrication. At high speed, continuous lubrication is necessary as a cooling medium. Graphitized laminated phenolic materials also develop less internal heat, making them superior for high-speed requirements.

As with gears, the choice of the mating material is important. The use of bronze, aluminum, and soft steel for rolls should be avoided. Hardened steels and heat-treated cast iron are to be preferred. Here again, surface finish and accurate machining of cam and roll are important. Care must also be taken to have sufficient material between the surface of the track and the hub; otherwise surface failure will occur.

A phenomenon that merits consideration is the aging process that takes place in laminated phenolic materials. Tests show that the limits of surface endurance increase with time, but so far the exact relation has not been determined.

#### SELECTING A LAMINATED PLASTIC

The selection of the correct grade of laminated material involves analysis of the operating conditions. In some cases there is no standard grade that is quite satisfactory. A table of properties alone does not provide enough data for an intelligent decision. Just as in alloy steels, it is necessary to know where the particular specification is regularly applied as well as its limitations.

Generally, four operating conditions will affect the choice.

**Electrical:** Where electrical insulation is the prime factor, consider the voltage and how it is applied. All standard dielec-

TABLE 40.—PROPERTIES OF LAMINATED PLASTICS\*

N.E.M.A. classification	Base	Average flexural strength, lb. per sq. in.	Average tensile strength, lb. per sq. in.	Average compressive strength, lb. per sq. in.	Average water absorption, per cent	Average dielectric strength, short-time volts per mil. 25 deg. C.	Applications
X	Paper	21,000	12,500	35,000	4.0	700	Panels for contactors, terminal boards, etc., straight mechanical uses where fabric-base grades are too costly. General electrical uses where parts are to be machined rather than punched. Low resin content, fair electrical properties, and machining quality. Does not punch readily. Navy <i>FBM</i> .
XP	Paper	15,000	8,000	22,000	3.0	700	Used for such applications as spacer, contact, and terminal boards, spool heads, switch links, and cross bars for knife-type switches. Better electrical properties and fair punchability. Navy <i>FBP</i> .
P	Paper	15,000	9,000	30,000	5.0	700	Used for washers, spacers, terminal boards where cold punching is required. Plasticized to facilitate intricate punching without heating.
XX	Paper	16,000	8,000	34,000	1.3	700	Excellent electrical grade. Insulation for relays, vibrators, switches. Good general-purpose grade. Machines well, punches hot. Uses resins of hard type. Navy <i>FEG</i> .
XXP	Paper	22,000	15,000	.....	1.5	700	Principally for radio and television parts where low electrical losses, low power factor, and electrical loss stability are essential. Uses resins of soft type. Low electrical losses, high power factor.
XXX	Paper	15,000	7,000	32,000	1.0	650	Radio parts, X-ray parts, and in general, parts to withstand high-voltage service. Minimum cold flow. With best dielectric strength, cold-flow properties, low moisture absorption. Machines excellently but is very difficult to punch.
XX	Paper	25,000	18,000	25,000	2.0	..	For refrigerator breaker strips and other applications where an odorless material is required.
C	Medium weave fabric	17,000	8,000	36,000	1.5	500	Gear blanks for 12-16 pitch. Motor slot wedges and other insulation where mechanical properties are prime requirements. Only fair electrical properties. Machines and punches excellently. Navy <i>FBM</i> .
C	Medium weave fabric with graphite	18,000	10,000	37,000	..	..	Used for mechanical applications where graphite content is desirable.
C	Medium weave fabric with heavy duck	22,000	10,000	37,000	4.4	150	Electrical and mechanical parts of $\frac{1}{8}$ - $\frac{1}{4}$ in. thickness requiring fabrication by punching because of intricate forms involved.
CE	Medium weave fabric with heavy duck	20,000	11,000	36,000	1.0	500	Rayon buckets, electroplating barrels, water- and steam-valve disks, friction disks. Machines excellently but abrasive on tools. Resists acid corrosion and retains physical properties under acid corrosive conditions better than other grades. Navy <i>FEG</i> .

C	Heavy duck	20,000	9,500	38,000	3.0	...	Gear blanks for pitches coarser than 16 D.P., spacers and other structural purposes. Primarily a gear material but used in other mechanical applications requiring toughness, resistance to wear, and good impact strength. Machines excellently but has rather coarse grain
C	Heavy duck	20,000	9,500	38,000	..	...	Water-lubricated bearings. Not designed for gear use because of abrasive wear on cutting tools
C	Extra heavy duck	19,000	11,000	40,000	..	...	Used for water-lubricated bearings on rolling mills. Used for bearings and other heavy-duty mechanical applications requiring highest toughness, impact strength, and resistance to wear
L	Fine weave fabric	20,000	9,000	35,000	2.0	...	Used for gears with fine pitch and mechanical parts requiring intricate machining
LE	Fine weave fabric	20,000	10,000	30,000	0.7	500	Highest dimensional stability. Used for rotary pump blades and other parts involving very close clearances. Also resistant to wear. Abrasive on tools
L	Fine weave fabric with graphite	20,000	10,000	37,000	1.2	...	Used for cams, worm gears, bearings, and any application involving sliding action. Wears to surface of nearly perfect smoothness. Used for mechanical applications requiring greatest resistance to wear under light or medium-duty loads
L	Fine weave fabric	20,000	11,000	30,000	..	..	Electroplating in alkaline solutions. Parts in contact with low concentrations of caustic solutions
L	Fine weave fabric	18,000	10,000	35,000	1.2	..	Ball- and roller-bearing retainers. Good dimensional stability and wear resistance
L	Very fine weave fabric	48,000	11,000	30,000	....	...	Used for clock and meter gears of fine pitch and retainers for ball bearings. Used where extra-fine texture is required
LE	Fine weave fabric	19,000	8,500	37,000	1.2	500	Best electrical properties available in any fabric base grade. Also used for punchings. Navy <i>FBE</i>
A	Asbestos paper	16,000	8,000	36,000	1.25	225	Field coil collars, welding electrode holders and other applications requiring resistance to higher temperatures than cellulose fillers will withstand. Rather low in electrical properties and toughness
AA	Asbestos cloth	20,000	10,000	38,000	1.5	..	Used for valve disks in contact with steam, bearings lubricated by steam, any part exposed to higher temperature than cellulose base materials will withstand. Has an inherently lower coefficient of thermal expansion, together with lower moisture absorption and therefore the highest dimensional stability. Has very high impact strength and resistance to wear, but is abrasive on tools. Has good resistance to chemical corrosion. Navy <i>FBH</i>
	Paper plus cloth	22,000	14,000	33,000	4.0	600	Radio punched parts and other punched parts requiring greater toughness. One cloth-surface sheet is used for increasing toughness. Likely to warp slightly because of unbalanced construction.
	Paper, urea base	20,000	11,000	25,000	....	...	Used for engraved name plates, with black surface and white letters
	Paper, urea base	20,000	16,000	25,000	....	...	Used for white decorative materials, such as name plates or panels
	Paper, urea base	25,000	13,000	30,000	....	...	Used for illuminated name plates and signs by engraving away the black surface exposing translucent filler
	Paper, urea base	25,000	13,000	30,000	1.5	500	Used for indirect lighting panels, louvers, troughs, and signs

\* From a table prepared by the General Electric Co.

tric tests are transverse to laminations because the materials are stressed in this direction in the majority of cases. If the voltage is applied to conductors passing transversely through the laminations, so that the stresses are parallel to the laminations, the dielectric strength of the material is reduced by about 80 per cent from standard specifications. It is well to remember that there is a substantial reduction in dielectric strength at elevated temperature.

No organic insulator is good in resistance to arcing because the temperature of a sustained power arc will be above charring point. In the case of the phenols, this charring causes a highly conductive carbon path with resulting destructive action. There are many applications, such as distributor heads, where the potential short-circuit current is small. In these cases it is possible to use a synthetic resin coating, or a face sheet with a urea melamine resin may be applied.

In electronic circuits, low losses and power factor may be the vital factors. Moisture absorption is a good measure of the adaptability of a material to this service. All insulators become less effective at ultrahigh frequencies. In addition, the power available may be so small that even a very low-loss may keep an oscillator circuit from functioning. It is also necessary on ultrahigh-frequency circuits to guard against corona. Conductors in contact with the material must have no sharp points from which corona might start and should fit snugly if mounted in holes.

**Mechanical:** In general, fabric-base grades are chosen where shock loads, repeated bending stresses, or resistance to wear are the vital criteria. The mechanical fabric-base grades are tougher than the electrical fabric-base grades; because the linen grades are made with lighter weight fabrics, the texture is finer and lends itself to machining into more intricate shapes.

A substantial improvement in wear resistance is possible by the use of graphitized material. Apparently owing to the very much smoother surface and consequent increased bearing area, the increased resistance to wear in such applications as worm gears and cams may be of the order of double or triple the wear resistance of the same grade without graphite.

The question of possible tolerances is always difficult. It is impossible to obtain pieces to the tolerances easily secured in

steel. In the first place the coefficient of thermal expansion is 0.00003 in./in.(deg.) for the fabric-base grades; 0.00002 in. per in. for the paper-base grades, or about three to five times as high as steel. Second, the material is about forty times as resilient as steel and a cutting tool never produces a permanent surface due to spring back. In addition, all grades have some moisture absorption with consequent dimensional change due to humidity.

For best dimensional stability, special grades are available. These usually have high resin content and as a result the moisture absorption has been reduced to a minimum. For highest dimensional stability under high humidity or total immersion conditions, the asbestos-fabric base has an inherently lower coefficient of thermal expansion and also a low moisture absorption.

Because of low specific gravity (one-half of aluminum and 75 per cent of magnesium), the physical strength divided by specific gravity (or specific strength) is very high. This justifies the use of plastics in airplanes, in applications involving high rotational speeds, and particularly in applications where resistance to chemical corrosion is also important. Most of the high-tensile-strength metals are not chemically resistant.

**Temperature:** As a rather rough rule, cotton fabric-base laminates may be used continuously at 95 and 120 deg. C. for short-time exposure. Cellulosic paper-base laminates may be used continuously at 120 and 150 deg. C. for short-time exposures. Asbestos-paper or woven-fabric grades, also glass-fabric grades, may be used continuously at 120 and 200 deg. C. for short-time exposures. These recommendations are only approximate because the effect of elevated temperatures may be different, depending on the applications. All grades tend to soften somewhat at temperatures above 100 deg. C., and, if exposed to mechanical stresses, may be deformed at lower temperatures than those suggested. If the material is supported, such as in insulating washers between two metal plates, it may withstand temperatures very much higher than those suggested.

Exposure to live steam at the same temperature will increase any tendency to age. The laminates are successfully used in live steam, but the temperatures suggested for paper-base materials should be reduced by 20 per cent. Woven-fabric laminates, owing to the skeletonlike organization caused by

weaving, do not disintegrate even after serious attack either by heat or by chemicals. Dielectric strength, insulation resistance, power factor, and electrical losses are all adversely affected as temperature is increased. Heat resistance of most grades can be increased by stabilizing the plastic by long annealing at a temperature higher than the temperature to which the material is to be exposed.

**Chemical:** In general, phenol laminates are not attacked by the common solvents, such as alcohol, ether, or the petroleum products. They resist low concentrations of the mineral acids except nitric and chromic. They resist excellently fruit acids, acetic, maleic, citric, ethyl lactate. They are attacked by the oxydizing acids, particularly at higher concentrations and elevated temperatures. They are also attacked by the alkalis—particularly sodium hydroxide.

On the other hand, phenol laminates retain strength in spite of chemical attack and may therefore have a long useful life. A rayon spinning bucket will have an average life of at least four years with almost constant exposure to a solution containing 15 per cent sulphuric acid, while operating at a peripheral speed of 20,000 ft. per min. and stressed by the load carried.

Laminated materials are indicated in applications requiring resistance to chemicals under conditions where the material must withstand high tensile stresses, and easy fabrication is desired.

Where intricate shapes of contours are involved, a lower cost of fabricating is obtained by the use of a punching grade in paper base, or if greater toughness is required in fabric base. In such cases electrical properties and moisture absorption can be considerably improved by waxing, or by coating with insulating varnishes. This treatment may also be desirable where the mold finish has been removed by sanding or machining.

As yet there is no universally accepted test for cold flow. There are, however, many designs where plastic deformation must not become too great for continued successful operation, and comparative figures may be useful, even though they are not expressed in numerical values. These are expressed in terms of flow under a time-pressure cycle. The lower the figure the less is the cold flow.

## CHAPTER XVII

### PLYWOODS AND ADHESIVES

Engineering properties of plywood panels depend not only upon the physical properties of the specific species of woods used for the various plies or laminations, but also upon the number and thickness of the plies and the direction of the grain of the wood in the various plies.

A single veneer, depending upon the species, in general has a tensile strength three to five times the compressive strength for loads applied in the direction of the grain. Also the tensile strength along the grain may be twenty or more times the tensile strength perpendicular to the grain. In addition the modulus of elasticity along the grain is from fifteen to eighty times that across the grain.

By glueing together plies in a manner such that the grain of the wood in one ply is at right angles to the grain of wood in the adjacent plies, plywood panels can be constructed that have about the same strength both parallel and perpendicular to the edge of the panel.

Symmetrical stress distribution in plywood panels is obtained by using an odd number of plies and by arranging them so that for any ply of a particular thickness there is a parallel ply of the same thickness and of the same species or another with similar characteristics on the opposite side of the core equally removed from the core.

Where resistance to splitting is desired, as in plywood that is fastened along the edges, a large number of plies affords a stronger fastening than does a plywood made up of a few plies.

In panels of many thin plies the glued joints between plies will be less stressed by shrinkage strains due to changes in moisture than the joints in panels constructed of a smaller number of thicker plies.

**Simple Tension Parallel and Perpendicular to Grain:** The greater the number of plies used for a given panel thickness,

TABLE 41.—PROPERTIES OF PLYWOOD PANELS OF RECTANGULAR CROSS SECTION

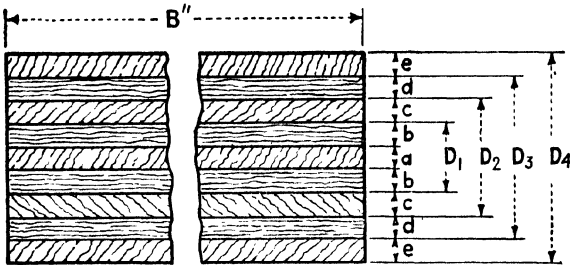

Cross section of plywood panel with plane of plies at right angles to direction of load.

- $D_1$  = Thickness of three-ply panel in inches  
 $D_2$  = Thickness of five-ply panel in inches  
 $D_3$  = Thickness of seven-ply panel in inches  
 $D_4$  = Thickness of nine-ply panel in inches

$$\text{Moment of inertia } I = \frac{K_1 B}{12}$$

$$\text{Section modulus } R = \frac{K_1 B}{6K_2}$$

Grain of Face Plies Parallel to Span

Number of plies in panel	$K_1$	$K_2$
3	$D_1^3 - a^3$	$D_1$
5	$D_2^3 - (a + 2b)^3 + a^3$	$D_2$
7	$D_3^3 - (a + 2b + 2c)^3 + (a + 2b)^3 - a^3$	$D_3$
9	$D_4^3 - (a + 2b + 2c + 2d)^3 + (a + 2b + 2c)^3 - (a + 2b)^3 + a^3$	$D_4$

Grain of Face Plies at Right Angle to Span

Number of plies in panel	$K_1$	$K_2$
3	$a^3$	$a$
5	$(a + 2b)^3 - a^3$	$(a + 2b)$
7	$(a + 2b + 2c)^3 - (a + 2b)^3 + a^3$	$(a + 2b + 2c)$
9	$(a + 2b + 2c + 2d)^3 - (a + 2b + 2c)^3 + (a + 2b)^3 - a^3$	$(a + 2b + 2c + 2d)$

the more nearly will the tensile strength parallel to the edge of the panel approach the strength perpendicular to the edge of the panel when the plies are alternately parallel and across grain. Because the strength of a single ply in the direction of the grain is so much greater than the strength across the grain, the strength of only the plies with grain parallel to the direction of load is considered.

**Bending and Deflection of Plywood Panels:** For beam structures the moment of inertia of the cross section is computed by considering only those plies that have their grain running in a direction parallel to the span. For horizontal panels with

TABLE 42.—SPECIES OF WOOD FOR FACE PLYS TO MEET SERVICE REQUIREMENTS

Woods checked in column *A* are used to obtain hardness, resistance to abrasion, and fastening strength.

Woods checked in column *B* are used where finish or appearance is required.

Woods checked in column *C* are used for plywood that must be steamed or soaked, before being bent into a form or shape that is to be permanent after forming.

Woods checked in column *D* are used for flat panels in which high bending strength, or high column strength, with minimum weight is required.

Species	A	B	C	D
Beech	✓	✓	✓	
Birch, sweet or yellow	✓	✓	✓	
Hard maple	✓	✓	✓	
Black walnut	✓	✓	✓	
Soft elm		✓	✓	
Red gum, heart		✓	✓	
Soft maple		✓	✓	
Mahogany, African or true		✓	✓	
Sycamore		✓	✓	
Basswood				✓
Port Orford cedar				✓
Spanish cedar				✓
Fir, lowland white, or red or silver				✓
Tupelo gum				✓
West Coast hemlock				✓
Pine, white, sugar, pondosa, or white				✓
Yellow poplar				✓
Redwood				✓
Spruce, red, white, or Sitka				✓

TABLE 43.—STRENGTH VALUES OF VARIOUS WOODS PARALLEL TO GRAIN\*  
Based on 15 per cent of moisture content

Species	Specific gravity, average	Static bending			Compression fiber stress at elastic limit, lb. per sq. in.
		Fiber stress at elastic limit, lb. per sq. in.	Modulus of rupture, lb. per sq. in.	Modulus of elasticity, 1,000 lb. per sq. in.	
Hardwoods					
Ash, black . . . . .	0.53	6,400	11,900	1,340	4,050
Ash, commercial white . . . . .	0.62	8,900	14,800	1,460	5,250
Basswood . . . . .	0.40	5,600	8,600	1,250	3,370
Beech . . . . .	0.66	8,200	14,200	1,440	4,880
Birch . . . . .	0.68	9,500	15,500	1,780	5,480
Cherry, black . . . . .	0.53	8,500	12,500	1,330	5,100
Cottonwood . . . . .	0.43	5,600	8,600	1,190	3,520
Elm, rock . . . . .	0.66	7,900	15,000	1,340	5,180
Gum, red . . . . .	0.53	7,500	11,600	1,290	4,050
Hickory . . . . .	0.79	10,600	19,300	1,860	6,520
Mahogany, African . . . . .	0.47	7,900	10,800	1,280	4,280
Mahogany, true . . . . .	0.51	8,800	11,600	1,260	4,880
Maple, hard . . . . .	0.67	9,500	15,000	1,600	5,620
Oak, white and red . . . . .	0.69	7,800	13,800	1,490	4,950
Yellow poplar . . . . .	0.43	6,000	9,100	1,300	3,750
Softwoods					
Cedar, incense . . . . .	0.36	6,000	8,700	1,020	4,320
Cedar, northern white . . . . .	0.32	4,700	6,600	700	3,040
Cedar, Port Orford . . . . .	0.44	7,400	11,000	1,520	4,880
Cedar, western red . . . . .	0.34	5,100	7,800	1,030	4,000
Cypress, southern . . . . .	0.48	7,100	10,500	1,270	4,960
Douglas fir . . . . .	0.51	8,000	11,500	1,700	5,600
Pine, northern . . . . .	0.38	5,900	8,700	1,140	3,840
Pine, Norway . . . . .	0.51	8,500	11,900	1,560	5,280
Pine, sugar . . . . .	0.38	5,600	8,000	1,040	3,680
Pine, western white . . . . .	0.42	6,000	9,300	1,310	4,240
Spruce . . . . .	0.40	6,200	9,400	1,300	4,000

Modulus of rupture is not a true stress. It is the value obtained by substituting maximum bending moments of rectangular beams in the ordinary beam formula. When the design stresses for fiber stress at elastic limit in bending, or the modulus of rupture, as given in the table are used in the design of beams the sections of which are not rectangular, factors whose values depend upon the shape of the cross section must be applied.

\* From tables compiled by U. S. Forest Products Laboratory.

plies of equal thickness, therefore, since the number of plies having their grain parallel to the face plies is one greater than the number of plies with grain at right angles to the face, the moment of inertia is greater when the grain of the face plies is parallel with the span. Data covering form factors used to calculate the strength of composite beams and columns should be arrived at after consultation with the plywood manufacturer.

#### ADHESIVES FOR PLYWOODS

The earliest glues were vegetable mucilages and animal glues. Whereas they supplied good bonds under dry conditions, these invariably failed if the joints became damp. Casein and blood glues achieve definite superiority over animal glues with respect to water resistance. The protein glues were susceptible to fungus attack under damp conditions, bringing about subsequent delamination or breakdown of the bond. The addition of certain preservatives went a long way toward making these glues, particularly the blood adhesives, more stable than any glues that had heretofore been used. Yet plywood glued with these materials could not be considered absolutely waterproof. Soybean protein, blood albumin, and similar glues behaved in like manner.

The permanency of phenol and urea formaldehyde molding and the tackiness of intermediate condensation products of these resins led to their investigation as possible adhesives. Both resins could be made into adhesives having superior gluing properties, weather durability, and fungus resistance. There is a wide variety of resin glues, each having certain desirable or recognized properties. In Table 44 are listed the comparative properties of the several types of commercial glue.

**Pressing Operations:** The introduction of resin glues, particularly the cold-setting type, proved a boon to the small manufacturer of plywood products. They enabled him to manufacture resin-glued plywood without the large investment in hot-pressing equipment. There are three general methods of bringing about a suitable glued joint or bond.

In the case of cold assemblies, joints are held in contact by strong C clamps. Such glues setup at room temperature and usually have to remain in clamps overnight. With resin glues the time required for setting up can be reduced if the clamped

TABLE 44.—COMPARISON OF PLYWOOD ADHESIVES\*

Material	Source	Forms	Type of pressing operation	Ingredients sometimes added	Preparation for use	Life of mixture at 70 deg. F.	Spreading and handling equipment	Spread lb. per 1,000 sq. ft. dry basis—single surface coated	Assembly period in min.	Pressing conditions	
										Temp. deg. F.	Time, hr.
Animal glue, . . . . .	Hides and bones	Powder, flakes	Cold press	Water and preservatives	Soak in water overnight	Extended if preserved	Heater and roller spreader	25-33	Immediate assembly necessary	Room	4-18
Vegetable adhesives—starch.	Plant carbohydrates	Flour	Cold press	Water and alkalis	Usually mixed hot	Several days	Roller spreader	20-33	10-40	Room	4-18
Blood albumen . . . . .	Dried beef, blood	Powder, flakes	Cold and hot press	Water, alkalies, paraformaldehyde, etc.	Mix cold	2 hr. to several days	Roller spreader	15-33	10-40	180-250	
Soybean and vegetable protein.	Soybean meal, peanut and cottonseed meal	Flour	Mainly hot—some cold	Water, silicate of soda, etc.	Mix cold	Several hr. for cold press	Roller spreader	25-37	10-40	Room temperature for cold press	2-5
Casein . . . . .	Milk	Powder	Mainly cold—some hot	Alkalies, formaldehyde, etc.	Mix cold	2 hr. to 2 days	Roller spreader	15-33	10-40	Room temperature for cold press. 180-250 for hot press	
Urea formaldehyde resin	Urea and formaldehyde	Liquids, powder	Hot and cold	Water accelerators extenders	Mix with water accelerator and extenders, if used	Several hr.	Rubber roller spreader	12-27	10 to several days	Room temperature for cold press. 210-240 for hot press	
Phenol formaldehyde resin.	Phenol and formaldehyde	Liquids, powder, dry films	Hot and cold	Water, alcohol, etc.	Powder is dissolved in alcohol. Film is used as is	Several hr. Extended for films	Rubber roller spreaders. Film requires table and cutter bar	15-30 film 12-25 hot-press liquid 25-40 cold-press	10 to several mo.	280-340	

\* Courtesy of Chemical and Metallurgical Engineering.

TABLE 44.—COMPARISON OF PLYWOOD ADHESIVES.—(Continued)

Material	Conditioning of veneers		Shear strength			Fungus resistance	Staining	Interference with other bonds	Exterior durability	Effect on veneer of catalyst or gluing temperature	Extensibility	Relative costs
	Moisture content before pressing, per cent	After pressing	Dry bond	48-hr. soak	Forest products cycle							
Animal glue. . . . .	3-8	Unnecessary for hot press, necessary for cold press. Dry to 7 per cent for indoors, 12 per cent for outdoors	High	Poor	Poor	Poor	Low	None	Poor	None	None	High
Vegetable adhesives—starch. . . . .	3-8	Same as above	Medium	Poor	Poor	Poor	Marked	Marked	Poor	Varies	Sometimes added to urea glues	Low
Blood albumen. . . . .	3-8	Same as above	High	Medium	Medium	Poor	Low to high	Marked	Fair to good	Varies	Sometimes added to urea glues	Medium to high
Soybean and vegetable protein. . . . .	3-8	Same as above	Medium	Fair	Fair	Poor	Marked	Marked	Poor to fair	Varies	Sometimes added to silicate of soda	Low
Casein. . . . .	3-8	Same as above	High	Poor to medium	Poor to medium	Fair	Marked	Marked	Poor to fair	Varies	None	Medium to high
Urea formaldehyde resin. . . . .	5-15	None	High	High	High	Unaffected	None	None	Good to excellent	None	Wide range of extenders	Low to high
Phenol formaldehyde resin. . . . .	8-12		High	High	High	Unaffected	Medium to high	Marked	Excellent	Varies. High temperatures effect wood	Protein extenders may be used	High

joints are kept in a warm place, since the setup of the glue is a function of temperatures; the higher the temperature, the faster is the action. Obviously, for thick joints, or in gluing lumber of large dimensions (particularly in thickness), heat reaches the glue so slowly that cold-setting glues are a prime requisite. It was for such purposes that they were developed.

Flat work, such as plywood, can be pressed between cauls placed between the platens of large presses. Obviously, heat can be used to advantage to bring about a rapid setup of the bond. The thicker the panels, the longer is the pressing operation. Each glue manufacturer publishes data regarding the setup rate of his glues.

Curved pieces were formerly made with difficulty, requiring steaming operations. An autoclave is employed as a pressure chamber, with hot water and compressed air as temperature and pressure exchange mediums. Variations of this process are used in the production of plastic-wood airplanes. The Timm, Duramold, and Vidal processes employ operations based on variations of this idea.

**Ingredients Added to Mix:** Some glues are merely mixed with water and applied directly to the members to be bonded. Most glues can be compounded with other materials either to cheapen the mixture, to facilitate the ease of handling, or to improve the quality of the bond. Most of the resin glues require the addition of hardeners or catalysts. Without these they would not set up as quickly to form waterproof bonds. Such adhesives are known as two-part glues. Urea resin glues are available with the hardener already added and require only mixing with water. They are known as one-part glues. These two-part and one-part resins are identical in quality; however, the choice of either one is dictated by the quantities of glue to be used. If the glue is used in small quantities, the ready mixed (one-part) is the simpler. If, however, large batches are used, it is desirable to employ the two-part glue as the resin can be mixed and the hardener added to small batches, which are drawn off as needed. The resin without the hardener has a working life of several days. After the hardener has been added, working life is reduced to a few hours, depending on the temperature.

Some manufacturers who use two-part resin glues prefer to add a dye to the hardener so that visual inspection will show if through carelessness in mixing the hardener was not incorporated.

Unextended resin glue bonds are more expensive than the earlier animal and vegetable types. Resin glues may be extended with inexpensive materials, such as flour, dextrose, and dried blood, bringing them into line from an economic point of view. The fact that resins can be extended with these materials is a particularly attractive feature because it permits a relatively high quality glue at little additional cost as compared to vegetable glues. Furthermore, it is possible, by use of these extenders, to devise the proper glue formula for a specific job.

**Preparation for Use:** Glues are messy materials to handle. The old animal gluepot has given way to electric mixers for the resin adhesives which can be kept spick-and-span with a normal amount of attention. Resin glues will gel on standing and the mixer operator soon learns not to let his mixture stand too long. Obviously, the least messy glue is the film-form phenolic resin. Its use is limited to flat or relatively flat presswork and for hot pressing. In using film glue it is essential that the surfaces of the wood to be bonded are relatively smooth. Furthermore, it is necessary to adjust carefully the moisture content of the veneers before the gluing operation. Most of the other resin glues are supplied in fine powder, which readily mixes with water and can be used immediately.

**Life of Mixture:** Resin glues are partly polymerized products which, when completely polymerized setup to hard, infusible, water-insoluble products. The bonding operation consists of bringing about this completely polymerized stage. Catalysts create the necessary condition, but the rate of polymerization or setup is a function of temperature. A urea glue that will set up to a gel in 5 hr. at 70 deg. F. becomes useless in 2 hr. at 90 deg. F. Obviously, the working life of a glue mixture is dependent upon the temperature of the mixture. By keeping the gluepot cooled with water, the working life of a resin glue can be extended appreciably. Animal and vegetable glues have a long liquid or working life provided they contain preservatives; otherwise they develop objectionable fungus growths.

**Spreading and Handling:** In using glues, particularly the resin adhesives, it is essential to spread the proper amount on the veneer. Too much glue is wasteful and may result in a weak bond. To bring about the proper spread, rubber roll spreaders are employed. Such equipment can be adjusted to handle veneers of various thicknesses, and the degree of spread

can be controlled closely. Film glues require a lay-up table equipped with a cutter bar or cutting machine.

As a rule veneers used for cores are spread with glue on both sides. In the case of cold glues these are assembled while the glue is still wet. With some hot-press glues the surface may dry since in assembly under pressure and temperature the glue fuses for a short period of time.

**Assembly Period:** After the veneers have been spread, they must be assembled within a definite period of time dependent upon humidity and temperature of the assembly room. Because the hardener is already in the glue, the film proceeds to set up and pressure must be applied before the action has gone too far. Certain urea and phenolic glues have extended assembly periods.

**Pressing Condition:** These may be varied over a wide range. In some cases, a long cure at a low temperature can be used; in other instances, a short period at high temperatures is desired. It is preferable to obtain as short a cure as possible at low temperature. Wood must contain a certain amount of moisture in order to be in good condition. If it is heated too high, not only is the water driven out but a subsequent deterioration may take place.

**Conditioning of Veneers:** In the case of most glues it is essential that the moisture content of the veneer be controlled, otherwise an inferior bond may result. In dealing with phenolics, poor bonds are apt to result if the water content drops below 6 per cent. Urea glues are less sensitive to the moisture content of the wood and require no special conditioning.

**Shear Strength:** Obviously, the major premise of a good glue is that it shall bring about a permanently strong bond. Tests for shear strength are made under several conditions. To judge a bond adequately it is essential to consider not only the shear strength in pounds per square inch, but also another factor, *viz.*, wood failure. Unfortunately, it is difficult to evaluate wood failure in some instances, and it requires a certain amount of experience.

Now that plywood is used indoors and outdoors, as well as for boats, life rafts, and airplanes, it is necessary to determine the quality through tests that give due consideration to both wet and dry conditions. Therefore, glue bonds are examined by

soaking test strips in water at room temperature for 48 hr., and testing them while wet. The Army-Navy specifications call for a three-hour boiling test of the resins for aircraft use. At present only phenolic resins meet this exacting test. The Forest Products Laboratory has developed a test that more nearly approximates outdoor conditions. It consists in alternately soaking and drying out the sample. After a definite number of cycles the shear strength is determined. Only satisfactory glues pass this rigid test.

**Interference with Other Bonds:** With the development of the several types of resin adhesives, each requiring specific curing catalysts, complications were bound to arise. Casein glues are alkaline, ureas require acidic conditions, and most phenolics set up in the alkaline region. In gluing thin veneers it is essential that the glue does not bleed through, bringing to the surface a condition unfavorable to the use of other glues.

**Extensibility:** Adhesives, when used straight, cost in proportion to the amount necessary to obtain a good bond and the relative cost per pound of the dry glue. If the glue is expensive but can be extended with a cheaper material without unduly affecting the quality of the bond, significant cost reduction can be made. Urea resin glue can be extended with a variety of materials, the best and cheapest of which is wheat flour. As much as 50 parts of flour can be added per 100 parts of cold-press type of dry glue. Extensions beyond this amount will reduce the waterproofness and strength of bond.

**Remarks:** Resin-bonded plywoods and resin-bonded assemblies are recognized as superior, durable building materials. At this time the bulk of such materials is going into national defense use, and compliance with the General Preference Order M-25 of the Office of Production Management leaves little, if any, for civilian use. When affairs return to normal, there will be a time-tested, inexpensive material for building purposes. Prefabricated houses of inexpensive construction, but absolutely durable, will be made available.

At the present time, resin-bonded materials are being subjected to conditions they never will be expected to meet in normal service. Plywood life rafts, urea glued, must and do stand up in actual service in warm and cold salt water for long periods of immersion. Even worse, they must withstand the baking

temperatures of noonday sun on hot steel decks in the presence of high humidities. Plywood airplanes must keep flying in temperatures ranging from 150 to  $-50$  deg. F.

#### VULCANIZED FIBER WITH WOOD CORE

In order to obtain all the advantages of plywood plus other desired properties, special types of ply materials have been developed. One of these, known as Fybr-Tech, consists of a wood veneer core with vulcanized fiber sheets bonded to one or both faces. Fiber faces are tough, nonsplintering, corrosion resistant, uniform in strength and thickness, and have a smooth surface that requires no preparation for paint lacquer or varnish finishing.

The weight varies with the thickness of fiber facing and total thickness. For a rough approximation, Fybr-Tech has about one-half the weight of aluminum. For estimating weights of sheets of other thicknesses,  $\frac{3}{8}$ -in. veneer weighs about 1 lb. per sq. ft. Fiber sheet weighs about 0.068 lb. per sq. ft. per 0.010 in. thickness. Weight of the resin bonding or glue can be disregarded.

Standard three or more ply sheets, consisting of a veneer core and two fiber faces or a veneer core, a fiber face and a veneer back, are obtainable in thicknesses of  $\frac{1}{32}$ ,  $\frac{3}{64}$ ,  $\frac{1}{16}$ ,  $\frac{3}{32}$ ,  $\frac{1}{8}$ , and  $\frac{3}{16}$  in. Thickness of the fiber sheet may be 0.015 or 0.005 in. The panels can also be made with two veneer faces or with a fiber face and a veneer back. All thicknesses are  $\frac{1}{8}$  in. and greater and five-ply with two fiber faces and a three-ply veneer core.

Total thickness, in.	Thickness of fiber facings, in.			
	0.015	0.010	0.007	0.005
	Total weight, lb. per sq. ft.			
$\frac{3}{32}$	0.312	0.267	0.241	0.224
$\frac{1}{8}$	0.387	0.342	0.316	0.299
$\frac{3}{16}$ (five-ply)	0.537	0.492	0.466	0.499

The fiber itself has a tensile strength of 6,000 lb. per sq. in. with the grain and about 8,700 lb. per sq. in. across the grain.

The strength of the panel will vary appreciably according to the thickness of the fiber.

Strength parallel to grain per unit weight is comparable to that of pure aluminum.

**Workability:** Fybr-Tech can readily be punched, drilled, sawed, and machined with ordinary tools. It can be bent to a single curvature on hot rolls to a radius as small as  $\frac{1}{2}$  in., and is shaped more readily than conventional plywood, with virtually equal pliancy both with and across the grain. Molding to compound curvatures of large radii is possible.

**Dielectric Strength:** Dielectric strength varies according to various factors, but a minimum of 300 volts per mil of thickness can be depended on.

**Corrosion Resistance:** It is resistant to acetic and carbolic acid, ammonia, gasoline, turpentine, linseed oil, cottonseed oil, machine oil, and alcohol. It will be injured by strong acids, such as nitric, hydrochloric, and sulphuric.

**Fire Resistance:** The material is slow burning and does not support combustion. It can be made fireproof by a surface treatment.

**Surface:** It is tough and scratchproof. It has a nonsplitting surface, which absorbs paints readily, giving a smooth level finish.

**Applications:** This material is being used successfully to replace aluminum sheets in streetcars, buses, and passenger trains for interior paneling under windows; in trucks and trailers for headlinings, flush paneling, instrument panels, seat backs; in marine construction for cabin paneling, bunks, furniture, ceilings, and floors. It has found applications in aircraft where extreme rigidity is not required.



## APPENDIX

### DIRECTORY OF TRADE NAMES, SUPPLIERS, AND MOLDERS

In the following listings, only the more usual plastics materials are listed by trade name and manufacturers. No attempt has been made to include all types of plastics materials, as that is beyond the scope of this book, which is concerned principally with plastics for industrial uses. The engineer may find the listings of molders and extruders valuable. These are believed to be the most complete listings available in any book on plastics.

#### MOLDING MATERIALS

##### Phenolic Materials

Bakelite	Bakelite Corp., New York
Coltrock	Colt's Patent Fire Arms Mfg. Co., Hartford, Conn.
Durez	Durez Plastics & Chemicals, Inc., North Tonawanda, N.Y.
Durite	Durite Plastics, Philadelphia, Pa.
Haveg	Haveg Corp., East Newark, Del.
Heresite	Heresite & Chemical Co., Manitowoc, Wis.
Indur	Reilly Tar & Chemical Corp., Indianapolis, Ind.
Insurok	Richardson Co., Melrose Park, Ill.
Makalot	Makalot Corp., Boston, Mass.
Michrock	Michigan Molded Plastics, Inc., Dexter, Mich.
Neillite	Watertown Mfg. Co., Watertown, Conn.
Resinox	Monsanto Chemical Co., East Springfield, Mass.
Templus	Bryant Electric Co., Bridgeport, Conn.
Textolite	General Electric Co., Pittsfield, Mass.

##### Cast Phenolic

Bakelite	Bakelite Corp., New York
Catalin	Catalin Corp., New York
Gemstone	A. Knoedler Co., Lancaster, Pa.
Marblette	Marblette Corp., Long Island City, N.Y.
Opalon	Monsanto Chemical Co., East Springfield, Mass.
Prystal	Catalin Corp., New York

##### Ureas

Bakelite	Bakelite Corp., New York
Beetle	American Cyanamid Co., New York
Cibanoid	Ciba Corp., New York
Plaskon	Plaskon Co., Toledo, Ohio
Uformite	Resinous Products & Chemicals Co., Philadelphia, Pa.

## Acrylics

Crystalite	Rohm & Haas, Philadelphia, Pa.
Lucite	E. I. duPont de Nemours & Co., Arlington, N.J.
Plexiglas	Rohm & Haas, Philadelphia, Pa.

## Vinyls

Alvar	Shawinigan Prod. Corp., New York
Butacite	E. I. duPont de Nemours & Co., Wilmington, Del.
Butvar	Shawinigan Prod. Corp., New York
Formvar	Shawinigan Prod. Corp., New York
Gelva	Shawinigan Prod. Corp., New York
Koroseal	B. F. Goodrich Co., Akron, Ohio
Vinylite	Carbide & Carbon Chemical Corp., New York

## Vinylidene Chloride

Saran	Dow Chemical Co., Midland, Mich.
-------	----------------------------------

## Polystyrene

Bakelite	Bakelite Corp., New York
Loalin	Catalin Corp., New York
Lustron	Monsanto Chemical Co., East Springfield, Mass.
Styron	Dow Chemical Co., Midland, Mich.

## Cellulose Acetate

Bakelite	Bakelite Corp., New York
Cellulate	National Plastics Co., Detroit, Mich.
Fibestos	Monsanto Chemical Co., East Springfield, Mass.
Gemloid	Gemloid Corp., New York
Lumarith	Celanese Celluloid Corp., New York
Macite	Manufacturers Chemical Corp., Jersey City, N.J.
Nixonite	Nixon Nitration Works, Nixon, N.J.
Plastacele	E. I. duPont de Nemours & Co., Arlington, N.J.
Tenite I	Tennessee Eastman Corp., Kingsport, Tenn.

## Cellulose Acetate-butyrates

Tenite II	Tennessee Eastman Corp., Kingsport, Tenn.
-----------	---

## Ethyl Cellulose

Ethocel	Dow Chemical Co., Midland, Mich.
Hercules	Hercules Powder Co., Wilmington, Del.

## LAMINATED MATERIALS

Aqualite	National Vulcanized Fibre Co., Wilmington, Del.
Celeron	Continental Diamond Fibre Co., Newark, Del.

Coffite	Formica Insulation Co., Cincinnati, Ohio
Dilecto	Continental Diamond Fibre Co., Newark, Del.
Duraloy	Detroit Paper Products Co., Detroit, Mich.
Formica	Formica Insulation Co., Cincinnati, Ohio
Insurok	Richardson Co., Melrose Park, Ill.
Lamicoid	Mica Insulation Co., New York
Lamitex	Franklin Fibre-Lamitex Corp., Wilmington, Del.
Micarta	Westinghouse Elec. & Mfg. Co., East Pittsburgh, Pa.
Panelyte	Panelyte Corp., New York
Ohmoid	Wilmington Fibre Specialty Co., Wilmington, Del.
Phenolite	National Vulcanized Fibre Co., Wilmington, Del.
Spauldite	Spaulding Fibre Co., Tonawanda, N.Y.
Synthane	Synthane Corp., Oaks, Pa.
Taylor	Taylor Fibre Co., Norristown, Pa.
Textolite	General Electric Co., Pittsfield, Mass.
Ucinite	Ucinite Co., Newtonville, Mass.
Vuleoid	Continental Diamond Fibre Co., Newark, Del.

## PLASTIC EXTRUDERS

American Molded Products Co., Chicago, Ill.
American Plastics Corp., New York
Anchor Plastics Corp., New York
Anthony & Anthony, New York
Atlantic Plastics, Cleveland, Ohio
Auburn Button Works, Inc., Auburn, N.Y.
Berkander, Inc., Geo. F., Providence, R.I.
Blum & Co., Inc., Julius, New York
Buchsbaum & Co., South Chicago, Ill.
Carter Products Corp., Cleveland, Ohio
Celluplastic Corp., Newark, N.J.
Chicago Molded Prod. Co., Chicago, Ill.
Cruver Mfg. Co., Chicago, Ill.
Detroit Macoid Corp., Detroit, Mich.
Erie Resistor Corp., Erie, Pa.
Extruded Plastics, Inc., Norwalk, Conn.
Extrusion Inc., New York
Firestone Rubber & Latex Prods. Co., Fall River, Mass.
Foster Grant Co., Inc., Leominster, Mass.
Freyberg Bros., Inc., New York
Gemloid Corp., Elmhurst, L.I., N.Y.
General Molding Co., Rockledge, Pa.
Gering Products, Inc., Kenilworth, N.J.
Injection Molding Corp., New York
Insel Co., The, Arlington, N.J.
International Molded Plastics, Inc., Cleveland, Ohio
Irvington Varnish & Insulator Co., Irvington, N.J.
Irwin Corp., New York

Jay Novelty Co., New York  
 Kingman Co., E.B., Leominster, Mass.  
 Linsky Co., The M.A., Los Angeles, Calif.  
 Mack Molding Co., Wayne, N.J.  
 Michigan Molded Plastics, Inc., Dexter, Mich.  
 Mills Corp., Elmer E., Chicago, Ill.  
 Multi-Plastics Corp., Los Angeles, Calif.  
 Nixon Nitration Works, Nixon, N.J.  
 Pierce Plastics, Inc., Bay City, Mich.  
 Pittsburgh Plastics Co., Inc., New Kensington, Pa.  
 Plastex Trim Corp., Columbus, Ohio  
 Plastic Process Co., Los Angeles, Calif.  
 Plastikon Co., The, Baltimore, Md.  
 Plax Corp., Hartford, Conn.  
 Recto Molded Products, Inc., Cincinnati, Ohio  
 Resistoflex Corp., Belleville, N.J.  
 Respro Inc., Cranston, R.I.  
 Rex Co., Inc., The, Cambridge, Mass.  
 Reynolds Spring Co., Molded Plastics Div., Cambridge, Ohio  
 Richardson Co., The, Melrose Park, Ill.  
 St Louis Plastic Moulding Co., St. Louis, Mo  
 Sandee Mfg. Co., Chicago, Ill.  
 Sandralux Plastic Products, New York  
 Schwab & Frank, Inc., Detroit, Mich.  
 Shaw Insulator Co., Irvington, N.J.  
 Southern Plastics Co., Columbia, S.C.  
 Standard Products Co., The, Thermoplastics Div., Detroit, Mich.  
 Superior Plastic Co., Chicago, Ill.  
 Suprenant Electrical Insulation Co., Boston, Mass.  
 Tech-Art Plastics Co., Long Island City, N.Y.  
 Tower Co., Inc., The, Seattle, Wash.  
 Werner Co., Inc., R.D., New York  
 Western Felt Works, Chicago, Ill.  
 Wilson Metal Products Co., Columbus, Ohio  
 Zenith Plastics Inc., Cleveland, Ohio  
 Zinglass Products Co. of America, Inc., New York

## MOLDERS

Ability Mold & Die Works, Chicago, Ill.  
 Accessories Mfg. Co., Kansas City, Mo.  
 Accurate Molding Corp., Brooklyn, N. Y.  
 Ackerman Plastics Molding Co., Cleveland, Ohio  
 Acraglas Co., Santa Monica, Calif.  
 Adler Engineering Co., Hackettstown, N. J.  
 Advance Molding Corp., New York  
 Alden Products Co., Brockton, Mass.  
 All American Aircraft Products, Inc., Long Beach, Calif.  
 Allied Barrel Corp., Oil City, Pa.

Allied Plastics Corp., Los Angeles, Calif.  
American Hard Rubber Co., New York  
American Insulator Corp., New Freedom, Pa.  
American Molded Products Co., Chicago, Ill.  
American Molding Co., San Francisco, Calif.  
American Phenolic Corp., Chicago  
Amos Molded Plastics, Div. of Amos-Thompson Corp., Edinburg, Ind.  
Anfinsen Plastic Moulding, Aurora, Ill.  
Armstrong Cork Co., Lancaster, Pa.  
Arpin Products, Inc., Orange, N. J.  
Arrow Plastics Corp., Passaic, N. J.  
Artisan Plastic Moulding Co., Trenton, N. J.  
Atlantic Plastic & Metal Parts Co., Cleveland, Ohio  
Atlas Appliance Corp., Brooklyn, N. Y.  
Atlas Plastic Mfg. Co., Inc., Lynbrook, L. I., N. Y.  
Auburn Button Works, Inc., Auburn, N. Y.

Baker, Willoughby, Oakland, Calif.  
Ballard Plastics Corp., Seattle, Wash.  
Barber-Colman Co., Rockford, Ill.  
Barnes Plastic Co., Los Angeles, Calif.  
Bay Mfg. Div. Electric Auto-Lite Co., Bay City, Mich.  
Beaman Molded Products Co., Portland, Ore.  
Bergwood Molding Co., Kansas City, Mo.  
Berkander, Inc., George F., Providence R. I.  
Bolta Co., Lawrence, Mass.  
Boonton Molding Co., Boonton, N. J.  
Bridgeport Moulded Products, Inc., Bridgeport, Conn.  
Brill Monfort Co., Inc., Brooklyn, N. Y.  
Brogan, Byard F., Philadelphia, Pa.  
Butterfield, Inc., T. E., Naugatuck, Conn.  
Button Corp. of America, Newark, N. J.  
Bryant Electric Co., The Hemco Plastics Div., Bridgeport, Conn.

Caldwell Products, Inc., New York  
California Pacific Plastic Co., Los Angeles, Calif.  
California Plastic Molding Co., Los Angeles, Calif.  
California Plastics Co., San Francisco, Calif.  
Capac Mfg. Co., Capac, Mich.  
Cardinal Corp., Evansville, Ind.  
Celluplastic Corp., Newark, N. J.  
Central Die Casting & Mfg. Co., Inc., Chicago, Ill.  
Central Machine Works Co., Minneapolis, Minn.  
Chicago Die Mold Mfg. Co., Chicago, Ill.  
Chicago Molded Products Corp., Chicago, Ill.  
Chicago Plastic Mfg. Co., Chicago, Ill.  
Cinch Mfg. Corp., Chicago, Ill.  
Cincinnati Advertising Products Co., Cincinnati, Ohio

- Cincinnati Molding Co., Cincinnati, Ohio  
Claremould Plastics Corp., Newark, N. J.  
Cleveland Plastics, Inc., Cleveland, Ohio  
Climax Mfg. & Molding Corp., Canton, Ohio  
Colt's Patent Fire Arms Mfg. Co., Hartford, Conn.  
Columbia Protektosite Co., Inc., Carlstadt, N. J.  
Columbus Plastic Products, Inc., Columbus, Ohio  
Commonwealth Plastic Co., Leominster, Mass.  
Compo-Site, Inc., Paterson, N. J.  
Connecticut Hard Rubber Co., New Haven, Conn.  
Connecticut Plastic Products Co., Waterbury, Conn.  
Consolidated Molded Products Corp., Scanton, Pa.  
Continental Plastics Corp., Chicago, Ill.  
Cruver Mfg. Co., Chicago, Ill.  
Cutler-Hammer, Inc., Milwaukee, Wis.
- Dayton Insulating Molding Co., Dayton, Ohio  
Detroit Macoid Corp., Detroit, Mich.  
Diemolding Corp., Canastota, N. Y.  
Drell Novelty Mfg. Co., New York  
Dullon-Beck Mfg. Co., Irvington, N. J.  
D & W Tool Co., Glendale, Calif.
- Eagle Plastics Corp., Long Island City, N. Y.  
Eastern Plastic Products Corp., Pittsburgh, Pa.  
Eby, Inc., Hugh H., Philadelphia, Pa.  
Eclipse Moulded Products Co., Milwaukee, Wis.  
Economy Fuse & Mfg. Co., Chicago, Ill.  
Emeloid Co., Inc., Arlington, N. J.  
Erie Plastics Co., Erie, Pa.  
Erie Resistor Corp., Erie, Pa.  
Eureka Button Co., New York
- Firestone Rubber & Latex Products Co., Fall River, Mass.  
Foster Grant Co., Inc., Leominster, Mass.  
Franklin Plastics Div. Robinson Industries, Inc., Franklin, Pa.
- Gardner Taubes Corp., New York  
Garfield Mfg. Co., Garfield, N. J.  
Gemloid Corp., Elmhurst, L. I., N. Y.  
General Electric Co., Plastics Dept., Pittsfield, Mass.  
General Industries Co., Elyria, Ohio  
General Molded Products, Inc., Des Plaines, Ill.  
General Molding Co., Rockledge, Pa.  
General Plastics Co., Los Angeles, Calif.  
General Products Corp., Union Springs, N. Y.  
Gesler Jewelry Co., Providence, R. I.  
Gibbs Manufacturing, Berkeley, Calif.

Gits Molding Corp., Chicago, Ill.  
Globe Tool & Molded Products Co., Rockford, Ill.  
Golden Gate Mfg. Co., Oakland, Calif.  
Grigoleit Co., Decatur, Ill.  
Grimes Mfg. Co., Urbana, Ohio  
Gulliksen Mfg. Co., Lower Falls, Mass.

Haas Corp., Mendon, Mich.  
Hyde Co., A. L., Grenloch, N. J.

Illini Molded Plastics, Hinsdale, Ill.  
Imperial Molded Products Corp., Chicago, Ill.  
Industrial Molded Products Co., Chicago, Ill.  
Ingwersen Mfg. Co., Denver, Colo.  
Injection Molding Co., Kansas City, Mo.  
Injection Molding Corp., New York  
Inland Mfg. Div., General Motors Corp., Dayton, Ohio  
Insel Company, Arlington, N. J.  
Insulation Mfg. Co., Inc., Brooklyn, N. Y.  
International Molded Plastics, Inc., Cleveland, Ohio

Janaison, H., Freeport, N. Y.

Kampa Mfg. Co., Milwaukee, Wis.  
K. C. Plastic Fabricators, Kansas City, Mo.  
Keasbey & Mattison, Ambler, Pa.  
Keeler Brass Co., Grand Rapids, Mich.  
Kellogg Switchboard & Supply Co., Chicago, Ill.  
Keolyn Plastics Co., Chicago, Ill.  
Keystone Specialty Co., Lakewood, Ohio  
Kilgore Mfg. Co., The (Plastics Div.), Westerville, Ohio  
Kingman Co., E. B., Leominster, Mass.  
Kling Bros. Eng. Works, Chicago, Ill.  
Kuhn & Jacob Molding & Tool Co., Trenton, N. J.  
Kurz-Kasch, Inc., Dayton, Ohio

Lanfare Molded Products Co., Toledo, Ohio  
Lapim Products, Inc., New York  
Lindenhurst Mfg. Co., Lindenhurst, N. Y.

McDonald Mfg. Co., Los Angeles, Calif.  
Mack Molding Co., Wayne, N. J.  
Marmont Plastics, Inc., New York  
Martindell Molding Co., Trenton, N. J.  
Maryland Plastics, Inc., Federalsburg, Md.  
Mason Co., Inc., The Thomas, Stamford, Conn.  
Master Plastic Molding Corp., St. Louis, Mo.  
Merrigan Plastic Co., Los Angeles, Calif.

Metal Specialty Co., Cincinnati, Ohio  
Micarmold Radio Corp., Brooklyn, N. Y.  
Michigan Molded Plastic, Inc., Dexter, Mich.  
Mico, Inc., Millerton, N. Y.  
Mill-O-Plast Co., New York  
Mills Corp., Elmer E., Chicago, Ill.  
Minneapolis Plastic Molding Co., Minneapolis, Minn.  
Minnesota Plastics Corp., St. Paul, Minn.  
Modern Machine Corp., Brooklyn, N. Y.  
Modern Plastic Co., Los Angeles, Calif.  
Modern Plastics Corp., Benton Harbor, Mich.  
Modglin Co., Los Angeles, Calif.  
Molded Insulation Co., Philadelphia, Pa.  
Molded Products Co., Chicago, Ill.  
Molded Products Co., St. Paul, Minn.  
Molding Corp. of America, Pawtucket, R. I.  
Morrell Corp., George, Muskegon Hts., Mich.

National Lock Co., Rockford, Ill.  
National Organ Supply Co., Erie, Pa.  
National Plastics, Inc., Knoxville, Tenn.  
New England Novelty Co., Leominster, Mass.  
New Products Corp., Benton Harbor, Mich.  
Niagara Insul-Bake Specialty Co., Inc., Albany, N. Y.  
Northern Industrial Chemical Co., Boston, Mass.  
Northwest Plastics, Inc., St. Paul, Minn.  
Norton Laboratories, Inc., Lockport, N. Y.

Ohio Plastic Co., Frazeyburg, Ohio  
Oris Mfg. Co., Inc., Thomaston, Conn.  
O'Shei, B. F., Buffalo, N. Y.  
Owens-Illinois Glass Co., Toledo, Ohio

Paragon Plastics, Inc., Seattle, Wash.  
Patent Button Co. of Tenn., Knoxville, Tenn.  
Paulis Plastics Co., H., Los Angeles, Calif.  
Peerless Molded Plastics, Inc., Toledo, Ohio  
Pierce Plastics, Inc., Bay City, Mich.  
Pittsburgh Plastics Co., Inc., New Kensington, Pa.  
Place Co., Roland P., Midland, Mich.  
Plano Molding Co., Plano, Ill.  
Plastal Specialties Co., Tacoma, Wash.  
Plas-Tex Corp., Los Angeles, Calif.  
Plastic Co., Inc., Los Angeles, Calif.  
Plastic & Die Cast Products Corp., Los Angeles, Calif.  
Plastic Engineering, Inc., Cleveland, Ohio  
Plastic Jewelry, Inc., Long Island City, N. Y.  
Plastic Molding Corp., Sandy Hook, Conn.  
Plastic Mouldings Corp., Cincinnati, Ohio

Plastic Products, Inc., Detroit, Mich.  
Plastic Products, Inc., New York  
Plastics Engineering Co., Sheboygan, Wis.  
Plastics, Inc., Bradley Beach, N. J.  
Plastics, Inc., St. Paul, Minn.  
Plastic Ware, Inc., New York  
Plastimold, Inc., Attleboro, Mass.  
Plastoid Corp., New York  
Poinsettia, Inc., Pitman, N. J.  
Potter & Brumfield Mfg. Co., Inc., Princeton, Ind.  
Precision Molded Plastics, Inc., Cleveland, Ohio  
Precision Plastics Co., Philadelphia, Pa.  
Pro-phy-lac-tic Brush Co., Florence, Mass.  
Pyro Plastics Co., Westfield, N. J.

Racine Universal Motor Co., Racine, Wis.  
Rathbun Molding Corp., Salamanca, N. Y.  
Raymond Laboratories, Inc., St. Paul, Minn.  
Recto Molded Products, Inc., Cincinnati, Ohio  
Reinhold Co., F. E., Los Angeles, Calif.  
Remler Co., Ltd., San Francisco, Calif.  
Resistoflex Corp., Belleville, N. J.  
Reynolds Spring Co., Cambridge, Ohio  
Richardson Co., Melrose Park, Ill.  
Robinson-Spear Corp., New York  
Rogan Bros., Chicago, Ill.  
Rogers, V. F., Denver, Col.  
Royal Moulding Co., Providence, R. I.

Safe-ty Socket Co., Gibson City, Ill.  
Salz Brothers, Inc., New York  
Schlotfeldt Specialty Co., Chicago, Ill.  
Scott Mfg. Co., The Geo. S., Plantsville, Conn.  
Seder & Son Molded Products Co., Fort Collins, Col.  
Seymour's & Co., Chicago, Ill.  
Shaw Insulator Co., Irvington, N. J.  
Sheller Mfg. Corp., Portland, Ind.  
Shephard Son & Co., J. II., Elyria, Ohio  
Sinko Tool & Mfg. Co., Chicago, Ill.  
Smith Molding Co., Frank B., Chicago, Ill.  
Sobenite, Inc., South Bend, Ind.  
Southern Plastics Co., Columbia, S. C.  
Southwest Machine & Plastic Co., Los Angeles, Calif.  
Specialty Insulation Mfg. Co., Inc., Hoosick Falls, N. Y.  
Stackpole Carbon Co., St. Mary's, Pa.  
Standard Cap & Molding Co., Baltimore, Md.  
Standard Electric Mfg. Co., Chicago, Ill.  
Standard Novelty Box Co., New York  
Standard Plastics Co., Attleboro, Mass.

- Standard Products Co., Detroit, Mich.  
Sterling Injection Molding, Inc., Buffalo, N. Y.  
Stokes Rubber Co., Jos., Trenton, N. J.  
Stone & Tupper, Inc., Clinton, Mass.  
Style Molders, Inc., Brooklyn, N. Y.  
Sulak Mfg. Co., Seattle, Wash.  
Superior Plastic Co., Chicago, Ill.  
Synthetic Moulded Products, Inc., Wakefield, R. I.  
Synthetic Plastics Co., Newark, N. J.
- Tech-Art Plastics Co., Long Island City, N. Y.  
Telex Products Co., Minneapolis, Minn.  
Terkelsin Machine Co., Boston, Mass.  
Ther Electric & Machine Works, Chicago, Ill.  
Tilton & Cook Co., Leominster, Mass.  
Toledo Plastics Co., Toledo, Ohio  
Trenton Metals & Plastics Co., Trenton, N. J.  
Tungsten Contact Mfg., Inc., North Bergen, N. J.  
Tupper, Earl S., Clinton, Mass.
- Uncas Mfg. Co., Providence, R. I.  
Union Insulating Co., Parkersburg, W. Va.  
United Comb & Novelty Co., Inc., Leominster, Mass.  
United Plastics Corp., Cleveland, Ohio  
Universal Button Fastening & Button Co., Detroit, Mich.  
Universal Plastics Corp., New Brunswick, N. J.
- Van Norman Molding Co., Chicago, Ill.  
Victor Mfg. & Gasket Co., Chicago, Ill.  
Victor Metal Products Corp., Brooklyn, N. Y.  
Victory Button Co., Leominster, Mass.  
Vichek, Tool Co., Plastics Div., Cleveland, Ohio  
Vulcanized Rubber Co., New York
- Ward Plastic & Rubber Co., Ferndale, Mich.  
Warren Plastics Corp., Warren, Pa.  
Washington Molding Co., Inc., Port Washington, N. Y.  
Waterbury Button Co., Waterbury, Conn.  
Watertown Mfg. Co., Watertown, Conn.  
Western Plastics Moulding Co., Los Angeles, Calif.  
Wheeling Stamping Co., Wheeling, W. Va.  
White Dental Mfg. Co., The S. S., New York  
Windman Bros., Los Angeles, Calif.  
Worcester Moulded Plastics Co., Worcester, Mass.  
Wright Plastics, Inc., New York
- Zenith Plastics, Inc., Cleveland, Ohio  
Ziwel Plastics Corp., Dover, Ohio

## INDEX

### A

- Acrylic resins, 8, 109
  - applications, 109, 110, 111
    - aircraft, 113*ff.*
  - cementing, 131-140
  - characteristics, 142
  - crazing tests, 143
  - forming of sheet, 127-131
  - light-piping, 111, 112
  - manufacture, 109
  - mounting of sheets, 114-127
  - physical properties, 139-140
  - repairing, 136
  - sheet thicknesses, 117
  - thermal, electrical properties, 141
- Adhesives and plywoods, 201-205
  - comparative adhesive properties, 206-207
  - handling, 209
  - ingredients, 208
  - pressing, 205
  - strength, 206, 207, 210

### B

- Basic compounding materials, 4*ff.*
- Binders, 4
- Blisters, 56, 59
- Buffing, 71

### C

- Cast phenolics, 98
  - applications, 99
  - design with, 100
  - fabrication, 98
  - properties, 102
- Cellulose acetate butyrate, 174
  - applications, 175-177
  - extruded, 177

- Cellulose acetate butyrate, properties, 178
- Cellulose acetate plastics, 9, 171
  - applications, 9
  - extruded, 177
  - properties, 171, 174
- Cellulose derivatives, 3
- Cementing acrylic sheet, 131-140
  - jigs, 137
  - joint preparation, 134
  - methods, 133
  - repairing and patching, 136-137
  - taping, 134, 135
  - types of cement, 131
- Compression molding, 27
  - basic principles, 27
  - of thermoplastic materials, 30
  - of thermosetting materials, 28
- Compressive strength, 16
- Coolants, 73
- Crazing, 143

### D

- Design, factors in, 1
  - fastening, 52
  - fillets, 47
  - inserts, 42, 43, 47, 48, 49, 50, 51
  - principles of, 40*ff.*
  - threads, 51
  - tolerances, 44
  - wall thickness, 46
- Dielectric constant, 21
  - comparative, 22
  - factors affecting, 22
- Dielectric strength, 22
  - comparative, 23
  - factors affecting, 22
- Directory, 215
- extruders, 217-218

Directory, materials, trade names, manufacturers, 215-217  
molders, 218-224  
Drilling, 72  
jigs for, 75

## E

Electrical properties, 20  
arc resistance, 24  
dielectric constant, 21  
comparative, 22  
dielectric strength, 22  
comparative, 23  
factors affecting, 20  
insulation resistance, 24  
loss factor, 24  
power factor, 23  
Embossing, 84  
Ethyl cellulose, 23, 181  
cementing, 182  
properties, 183  
types, 181  
Extruded tubing, 163  
Extruders, directory of, 217-218  
Extrusion, 27, 177

## F

Fastening, 52  
Faults in molded parts, 56  
blisters, 56, 59  
dull surface, 58  
flow marks, 65, 70  
mechanically weak, 60, 69  
orange peel, 58  
pitting, 58, 70  
poor welding, 67  
short, unfilled pieces, 61  
sticking to mold, 58  
thick flash, 57  
warping, 59, 64, 70  
Fillers, 5  
asbestos, 6  
barium sulphate, 7  
cotton, 5  
effects of, 5  
graphite, 6

Fillers, mica, 6  
rag, 6  
silica, 7  
talc, 7  
Fillets, 47  
Finishing and machining, 71*ff.*  
Flash, thick, 57  
Flow marks, 65, 70  
Forming acrylic sheet, 127  
forms used, 129  
heating, 128  
male and female forming, 131  
stretch forming, 130  
Fybr-Tech, properties, 212

## G

Gear cutting, 80

## I

Impact strength, 16  
effect, of design, 17  
of operating conditions, 17  
Injection molding, 29  
basic principles, 29  
Injection molds, 35  
Inserts, 42, 43, 47, 48, 49, 50, 51  
Insulating materials, properties, 154  
Insulation, high-frequency, 152  
Insulation resistance, 24

## J

Jigs, cementing, 136, 137  
machining, 75

## L

Laminated plastics, 185*ff.*  
cams, 193-195  
comparative properties, 189  
electrical properties, 193  
graphitized laminated, 191  
nomenclature, 187  
properties, applications, 196-197  
tubing, 192  
safe-operating temperature, 188

Laminated plastics, selection factors,  
195-200

types, 185-189

Lathe operations, 76

Loss factor, 24

## M

Machining and finishing, 71*ff.*

buffing, 71

drilling, 72

gear cutting, 80

lathe operations, 76

milling operations, 79

polishing, 84

punching, 82

reaming, 75

sawing, 80

threading and tapping, 76

Materials manufacturers, 215-217

Milling operations, 79

Moisture resistance, 25

Mold, design, 27, 30, 37

flash, 31

injection, 35

landed plunger, 33

loading-plate, 32

shrinkage, average, 55

straight-plunger, 35

subcavity, 30

transfer, 36

Mold steels, 39

Molders, directory of, 218-224

Molding, basic principles, 27*ff.*

processes, 27

Mounting acrylic sheet, 114

annular ring mountings, 120-122

bolt and rivet mountings, 123-127

channel and clamp mountings,  
118-120

expansion and contraction, 116

recommended thickness, 117

## O

Optical properties, acrylics, 111, 112

urea, 105

Orange peel, 58

## P

Phenol formaldehyde, 7, 86

applications, 7, 87, 90, 91

coatings, 94*ff.*

fillers, 88

general purpose, 88

heat-resistant, 90

low-frictional, 93

manufacture, 86

properties, 94

shock-resistant, 89

special, 91

transparent, 93

Phenol-furfural, 96

applications, 97

properties, 97

Phenolics, cast, 98

applications, 99

design with, 100

fabrication, 98

properties, 102

Physical properties

acrylics, 139-141

average, 14

cellulose acetate, 171

cellulose acetate-butyrate, 174

ethyl cellulose, 23

phenol formaldehyde, 94

phenol furfural, 97

polystyrene, 150

Styramic, 152

vinyl copolymers, 160

vinylidene chloride, 164-165

Pitting, 58, 70

Plastics, laminated (*see* Laminated  
plastics), 185

Plywood panels, adhesives for, 205-  
212

bending and deflection, 203

combined with vulcanized fiber, 212

moment of inertia, 202

properties, 201-205

wood species, 203

wood strengths, 204

Polishing, 84

Polystyrene, 8, 23, 24, 144

applications, 8, 144, 148

- Polystyrene, chemical resistance, 146, 151  
 effect of temperature, 146, 147, 148  
 light transmission, 146  
 properties, 150  
 Styramic, 152
- Polyvinyl acetate, 159  
 properties, 161
- Polyvinyl butyral, 161  
 properties, 161
- Polyvinyl chloride, 159  
 properties, 161
- Power factor, 23  
 comparative, 24  
 factors affecting, 23
- Properties, comparative, 11*ff.*  
 effect, of fillers, 14  
 of molding on, 14  
 of temperature, 16
- Punching, 82
- R
- Reaming, 75
- Resins, synthetic, 3
- Ribs, 42
- S
- Saran, 162
- Sawing operations, 80
- Saws for laminated plastics, 85
- Sheets, acrylic, 113-140  
 cementing and repairing, 131-140  
 forming, 127-131  
 mounting, 114-127
- Specific gravities, comparative, 13
- Styramic, 152  
 properties, 153
- Surface dullness, 58
- T
- Tables, accelerated tests on phenol coatings, 96  
 average physical properties, 14  
 bursting pressures, Saran tubing, 166
- Tables, chemical resistance of Saran, 167  
 common faults, causes and remedies, 56  
 comparative properties of vinyl resins, 161  
 crazing tests on Plexiglas, 143  
 dielectric strength, 23  
 dielectric constants, 22  
 electrical properties laminated plastics, 193  
 fillers for phenolics, 88  
 location and size of molded holes, 52  
 mold shrinkage, 55  
 plywood adhesives, 206-207  
 power factor, 24  
 properties, of acrylic resins, 139-142  
 of cast phenolics, 102  
 of cellulose acetate, 174  
 of cellulose acetate-butyrate, 178  
 of electrical insulating materials, 154  
 of ethyl cellulose, 183  
 of glass-laminated vs. fabric-laminated, 189  
 of laminated plastics, 196-197  
 of laminated tubing, 192  
 of phenol formaldehyde, 94  
 of phenol furfural resins, 97  
 of plywood panels, 202  
 of polystyrene, 150-151  
 of Saran tubing, 164-165  
 of Styramic, 153  
 of urea compounds, 107  
 of vinyl copolymers, 160
- saws for laminated plastics, 85  
 sheet thicknesses for aircraft, 117  
 service characteristics, Saran and copper, 168  
 specific gravities of materials, 13  
 strength of woods, 204  
 testing standards, A.S.T.M., 25  
 tests on graphitized laminated, 191  
 thermal expansion, 55

Tables, thermal properties, 18  
 water absorption, 26  
 wood species, 203  
 Tensile strength, comparative, 13  
 effect of molding on, 14  
 Testing standards for plastics, 25  
 Thermal expansion, average, 55  
 Thermal properties, 17  
 comparative, 18  
 Thermoplastic materials, definition,  
 2  
 Thermosetting material, definition, 2  
 Threaded inserts, 76  
 Threading and tapping, 76  
 Threads, 51  
 Tolerances in design, 44  
 Trade-names, 215-217  
 Transfer molding, 28  
 Transfer molds, 36  
 Types of plastics, 1*ff.*

## U

Urea formaldehyde, 8, 104  
 applications, 8, 104  
 characteristics, 104  
 design with, 106  
 properties, 107, 108  
 optical, 105

## V

Vinyl copolymer, 9, 155  
 applications, 9, 155, 157  
 properties, 160  
 Vinyl plastics, 155  
 polyvinyl acetates, 159  
 polyvinyl butyral, 161  
 polyvinyl chloride, 159  
 properties, comparative, 161  
 vinyl copolymer, 155  
 Vinylidene chloride, 10, 162  
 applications, 10, 170  
 chemical resistance, 167  
 comparative service characteris-  
 tics, 168  
 extruded tubing, 163  
 properties, 164, 165  
 working pressures, 166  
 fabrication, 162  
 fittings, 169

## W

Wall thickness, 46  
 Warping, 59, 64, 70  
 Water absorption, comparative, 26  
 Weight comparative, 11  
 Welding, poor, 67











