

UNIVERSAL
LIBRARY

OU_168162

UNIVERSAL
LIBRARY

OSMANIA UNIVERSITY LIBRARY

Call No. 669/c43.P Accession No. 20537

Author Chalmer^{v.1}s, B.

Title Physical examination of met

This book should be returned on or before the date
last marked below. / 1930

**THE PHYSICAL EXAMINATION
OF METALS**

THE PHYSICAL EXAMINATION OF METALS

BY

BRUCE CHALMERS

B.Sc., Ph.D., F. INST.P.

PHYSICIST, INTERNATIONAL TIN RESEARCH
AND DEVELOPMENT COUNCIL

VOLUME I

OPTICAL METHODS



LONDON

EDWARD ARNOLD & CO.

All rights reserved
First published in 1939

Printed in Great Britain by
Butler & Tanner Ltd., Frome and London

PREFACE

The demands of modern industry have led in recent years to a very striking advance in our knowledge of metals. This knowledge has come very largely from the application of scientific methods to the investigation of metals; and since the properties of metals that determine their usefulness are chiefly the physical properties, it is clear why the examination of metals by physical methods has become so important.

A stage has been reached at which certain physical methods of examining metals have become such an ordinary part of the metallurgist's technique that they have come to be regarded as metallurgical rather than physical methods. An example is the investigation of phase changes by cooling and heating curves. But while such methods have been incorporated as metallurgical methods, a number of physicists have been investigating various properties of metals by methods that are virtually unknown to those metallurgists who have not had special training in physics. Such methods are often looked upon with suspicion or ignored by metallurgists simply because they are not understood. The object of this book is to explain, in as simple language as possible, the physical theory underlying these methods, to describe the more important applications that have been made, and, where possible, to describe the technique so that the reader can apply it himself. In some instances it is not deemed practicable to describe the technique in detail because specialised training is required for its application. Such methods are included, however, because a general understanding of them leads to a better appreciation of the value and limitations of the results.

No claim is made to a complete treatment of the subject, and only a selection of the possible references to original work is given; if this were not so the book would become a mere catalogue of the experimental work that has been

done, instead of a guide to work that is being and might be done.

The book is to be published in two volumes, this, the first, dealing with Optical Methods. The second volume, in the preparation of which the author is enjoying the collaboration of Dr. A. G. Quarrell, of the University of Sheffield, will deal with the other branches of physics as applied to the investigation of metals.

B. C.

ACKNOWLEDGMENTS

Grateful acknowledgment is made to the following for the loan of blocks : the Council of the Iron and Steel Institute for Figs. 7, 8, 9, 10, 42, 43, 44, 45 ; the Council of the Faraday Society for Figs. 92, 93 ; the Council of the Institute of Metals for Fig. 35 ; and to the following for permission to reproduce the illustrations mentioned : the proprietors of the Metal Industry, London, Figs. 73, 74 ; the proprietors of *Nature*, Figs. 47, 48 ; the Council of the Electrodepositors Technical Society, Figs. 50, 51 ; also to the proprietors of the Metal Industry, the Council of the Institute of Metals and Dr. U. R. Evans for permission to quote certain passages.

CONTENTS

CHAP.	PAGE
I INTRODUCTION	1
II GEOMETRICAL OPTICS	5
Laws of reflection, optical lever, examination of surface irregularities, crystal orientation, shape of surface, crystal axes by slip bands, optical reflecting power, specular and diffuse reflection, shape of surface by diffuse reflection, scratch on tinplate, scattering due to tarnish, black stain on aluminium, measurement of reflectivity. Practical considerations. Reflection characteristics and metallography, fluorescence, total reflecting power, optical properties of thin films.	
III WAVE OPTICS. I: INTERFERENCE	35
Elementary treatment, parallel and inclined plate systems, sharpness and contrast of the fringes, Michelson interferometer. Applications; Newton's rings, measurement of elastic moduli, precision extensometer, plane bending apparatus, dilatometers, interference thermometer; practical considerations. Micro-topography, shape of sharp edge, micro-interferometer. Colours of oxide films; theory, relation between thickness and colour, effect of oblique incidence, applications. Colours of metal films. Interference micrometer, thickness of electro-deposits by interference fringes, measurement of elastic constants.	
IV WAVE OPTICS. II: DIFFRACTION	102
Elementary treatment, diffraction by edge, slit and wire; diffraction grating, measurement of mesh; measurement of size of powders. Resolving power of microscope, ultra-violet microscopy.	
V POLARISED LIGHT	117
Elementary treatment, detection of polarised light, elliptically polarised light. Applications, investigation of surface changes, relation between optical properties and composition, determination of micro-structure, state of strain, presence and nature of inclusions. Technique.	
VI SOURCES OF LIGHT.	160
Temperature radiation and characteristic radiation, radiation pyrometry. Spectrographic analysis; method of excitation, photography of spectra, qualitative and quantitative analysis.	
INDEX	177

PLATES

PLATE	TO FACE PAGE
I. REFLECTION PHOTOGRAPHS OF SAMPLES OF TINPLATE HAVING DIFFERENT THICKNESSES OF TIN COATING .	8
II. GREASE MARK ; NORMAL PORE ; TIN SURFACE CRYSTAL BOUNDARY ; RIDGED SURFACE EFFECT ASSOCIATED WITH GREASE LINES	71
III. ETCHED BABBITT METAL	72
IV. ELECTRODEPOSITED TIN, (i) SCRATCH-BRUSHED, (ii) POLISHED	73

PHYSICAL EXAMINATION OF METALS

OPTICAL METHODS

CHAPTER I

INTRODUCTION

It may be stated without fear of contradiction that all the main properties of light have been put to use in the examination of metals. A brief account of these properties will therefore be of service in linking up the chapters that follow and in avoiding frequent repetition or misunderstanding.

Most of the properties of light can be accounted for on the supposition that light consists of an electromagnetic disturbance in the æther propagated by means of a wave motion. The propagation of a wave depends upon the existence of a state of affairs in which the displacement of one particle from its position of rest causes the neighbouring particles to be similarly displaced an instant later. If a particle is made to vibrate regularly, its vibration will be transmitted through the neighbouring to the more distant particles, the disturbance travelling with a definite velocity. Thus in a wave motion a periodic disturbance is transmitted through a medium which remains practically in its original position.

The vibration from which the wave originates may take place either along the direction in which the wave travels or else at right angles to it. The former constitutes a longitudinal, and the latter a transverse wave. Three features characterise any particular wave motion, *i.e.* the frequency, or number of vibrations occurring per second, the amplitude or extent of the vibrations, and the wavelength or distance

between successive points that are vibrating in phase with each other. The frequency n and the wavelength λ are related to the velocity V by the equation $V = n \times \lambda$.

In the case of light, the disturbance, which is electromagnetic in character, is transverse to the direction of propagation. Light travels through empty space with the velocity of 3×10^{10} cm. per second (186,000 miles per second), and through transparent materials with smaller velocities. Such a disturbance produces the sensation of sight when its frequency is between about 4×10^{14} and 8×10^{14} per second. The colour of the light depends on the frequency, and therefore on the wavelength, in the manner shown in Fig. 1.

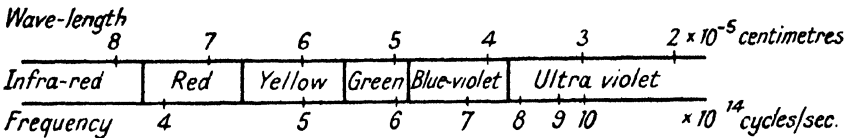

FIG. 1.—The Visible Spectrum.

One of the most obvious characteristics of light is the fact that it appears to travel in straight lines except when it passes from one medium to another. This is only strictly true when the scale of sizes considered is large compared with the wavelength of the light, and these facts, as well as the very simple laws that govern reflection and refraction, are accounted for in terms of the theory of wave motion. For many purposes it is sufficient to apply the laws of reflection and refraction without any consideration of the wave theory and the method then adopted is that of geometrical optics. Some of the applications of this method of treatment will be found in Chapter 2.

When sizes comparable with the wavelength are under consideration, effects which must be considered in terms of the wave theory become important; these effects can be regarded in the following way. Since light is a wave motion, the intensity of the light reaching any point depends on the displacement at that point due to the wave motion. It follows that if two waves reach a point simultaneously, the resulting effect will depend upon whether the two waves are causing displacements in the same or in opposite directions at the

same instant. If the directions are the same, the two waves add together to produce a greater intensity than either would alone ; if opposite, the two tend to cancel, and a reduced or zero intensity results. This is the process of interference, of which several aspects are treated in Chapters 3 and 4.

Another result of the fact that light is propagated as a transverse wave motion is that it is possible for light travelling in a given direction to consist of vibrations in any of an infinite number of directions, each of which is perpendicular to the direction of propagation of the wave. Ordinary light contains vibrations in all of these directions, but if light is produced in such a way that its vibrations are only in a single direction, it has special properties and is said to be plane polarised. The alteration of the characteristics of polarised light brought about by its reflection from a surface, and particularly from a metal surface, depends on the state of the surface and on its composition. Applications of this fact to the examination of metal surfaces are discussed in Chapter 5.

The characteristics of light depend upon the source from which the light comes, and suitable examination of the distribution of light in the spectrum yields considerable information about the chemical composition or the temperature of the source of the light. The final chapter deals with these two aspects of the subject.

The spectrum of visible light forms but a small fraction of the complete spectrum of electromagnetic waves, which ranges from the γ rays of radioactive substances, with a wavelength of 10^{-10} cm. to radio waves of wavelengths up to several thousand metres. The whole range is represented roughly in Fig. 2.

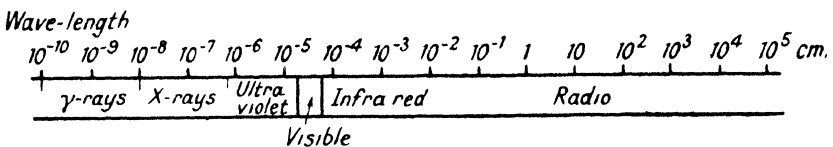

FIG. 2.—The Electromagnetic Spectrum.

These types of radiation all travel with the same velocity in empty space, and all travel more slowly in media which are transparent to them. The subject of optics, as its name implies, denotes the study of visible radiation ; it has, how-

ever, extended itself to deal with ultra-violet and infra-red radiation in so far as these behave analogously to light. X-rays on the one hand and radio waves on the other, behave quite differently from light on account of their very different wavelengths, and so they are not included under the heading of this volume. In order to avoid confusion it is as well to state here that lengths will generally be described in centimetres (cm.), or in Ångstrom Units (A.U.) ($1 \text{ A.U.} = 10^{-8} \text{ cm.}$).

It is not necessary to emphasise the limitations of optical methods of examining metals because it is evident that light can only give information about the extremely thin layer into which it penetrates, and that is only a few wavelengths at the most. At the same time it must be remembered that the surface of a metal is extremely important because it forms the chief protection against corrosion. The short wavelength involved means on the other hand that optical methods are of great value for making precision measurements of lengths.

It should be pointed out that although all the effects of geometrical optics, wave optics and polarisation can be accounted for in terms of the wave theory of light, there are certain other effects for which this theory offers no explanation. The quantum theory is invoked in order to supply an explanation of these effects. Such cases, which are those in which the emission and absorption of light by matter are concerned, are beyond the scope of this book and will not be considered here, although certain examples, such as the photoelectric effect, will be discussed in Volume II.

CHAPTER 2
GEOMETRICAL OPTICS

Laws of Reflection

The study of light has resulted in the evolution of two methods of accounting for and predicting the path of light through optical instruments, the method of geometrical optics and the method of wave optics. The geometrical method depends on the fact that unless magnitudes comparable with the wavelength are concerned, light can be regarded as travel-

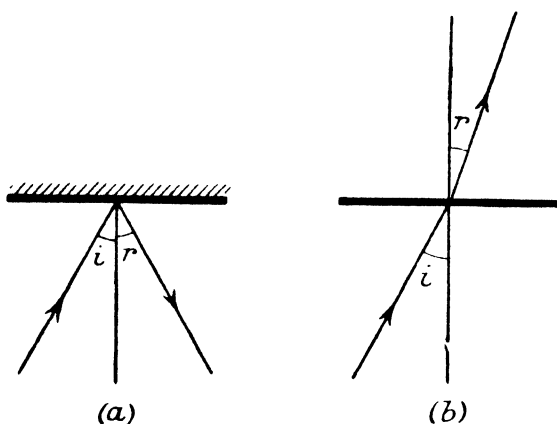

FIG. 3.—Laws of Reflection and Refraction.

ling in straight lines except where it reaches the boundary between two media, where it is reflected or refracted according to certain laws. The law which governs reflection is that the angle of reflection is equal to the angle of incidence, the incident and reflected rays and the normal being in the same plane. When refraction takes place, the ratio of the sine of the angle of refraction to the sine of the angle of incidence is a constant for a given pair of materials and wavelength of light, the two rays and the normal being coplanar.

Optical Lever

A common example of the application of the law of reflection is the optical lever, in which small changes of position are measured with a very large magnification. As a simple case, consider the use of the optical lever to measure the relative movement of two objects A and B (Fig. 4(a)). The instrument consists of an arm C resting on points or knife edges D and E, and supporting a mirror F. Relative vertical movement of

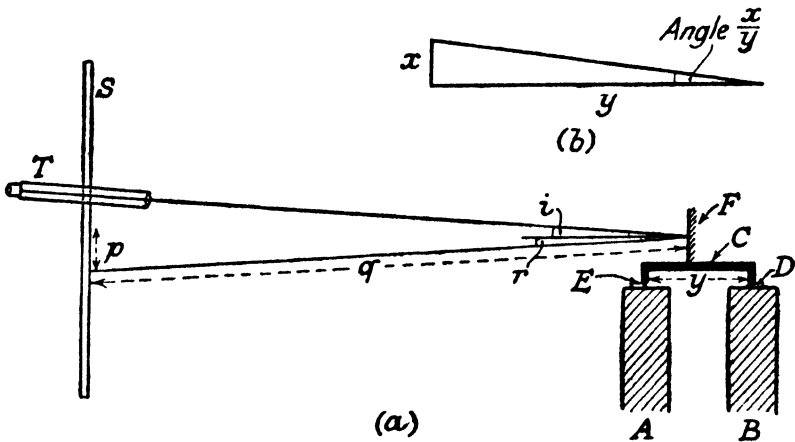

FIG. 4.—Optical Lever.

A and B causes the mirror F to change its inclination to the horizontal, and this change of angle is measured by means of a beam of light which serves as a long, weightless pointer. When the greatest precision is not required, an actual beam of light, as from a galvanometer lamp, can be directed on to the mirror F, and the position adjusted so that the reflected beam falls on the scale S. An alternative procedure, which permits a greater accuracy in the readings, is to observe the scale S through the telescope T *via* the mirror F. In the former case a reading is taken of the position of the centre of the spot of light on the scale. This is facilitated if the spot, which is a disc, is crossed by a line, which is the image of a crosswire in front of the lamp. For this purpose the mirror F should be a concave galvanometer mirror, and the lamp and the scale should both be placed one metre from the mirror. If it is desired to increase the distance from the mirror to the scale,

then the lamp must be placed correspondingly closer to the mirror. If the telescope system is used, the mirror must be plane, and the reading is taken where the eyepiece crosswire of the telescope crosses the image of the scale. Rotation of the mirror F causes the reading obtained in either of these ways to change. This change will be denoted by p cm.

Suppose A to rise a distance x , then the mirror will turn through an angle, which can be expressed as $\frac{x}{y}$ if x is small (see Fig. 4(b)), y being the distance between D and E. The normal to the mirror will turn through the same angle, reducing the angle of incidence I by this amount. The angle of reflection R will also decrease by this amount and so the reflected ray will turn through an angle $2\frac{x}{y}$. If the distance from mirror to scale is q , then

$$2\frac{x}{y} = \frac{p}{q} \text{ or } \frac{p}{x} = 2\frac{q}{y}$$

If q is 1 metre and y is 1 cm., the magnification of movement is 200.

This arrangement may be modified by the use of two or more mirrors, by means of which the magnification can be increased very considerably.

A slightly different method, often used for dilatometers, is to mount the mirror on a thin rod A (Fig. 5) which rolls between the two members B and C of which the relative motion is required. In this case the diameter of the spindle A replaces the distance y of Fig. 4.

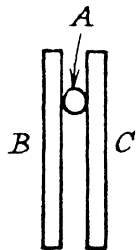

FIG. 5.—
Application
of Optical
Lever.

An important technical application of the optical lever method of magnifying small movements is in the contourgraph¹ in which the vertical movement of a very fine point passing over a turned, ground or polished surface is magnified so that a photographic record is obtained of the irregularities of the surface, the sensitivity being such that irregularities of two-millionths of an inch can be seen.

¹ Shaw, *J. Inst. Production Eng.*, 1936, 15, 369-91.

Examination of Surface Irregularities by Reflected Light

The reflection of light according to the simple geometrical law has various other applications, one of which has recently been described by W. E. Hoare¹ in connection with the examination of the surface of tinplate. This technique was devised for the study of the irregularities in the surface of tinplate that result from the hot-dipping process by which the steel sheet is coated with tin. These irregularities, some of which take the form of ridges spaced at intervals which vary from a few millimetres to two centimetres according to circumstances, are either straight or branched. They are not easily examined by visual inspection owing to their minute height.

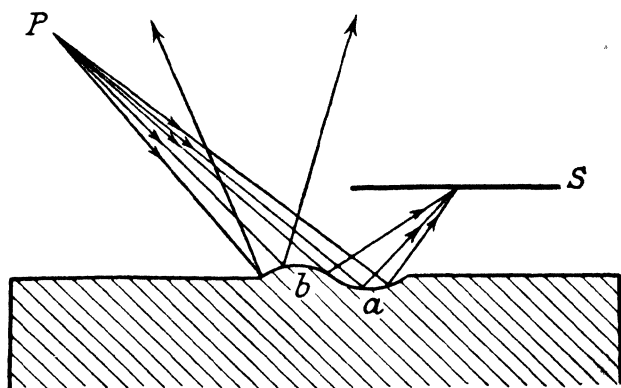

FIG. 6.—Examination of Tinplate by Reflection.

The method consists in projecting a diverging beam of light on to the surface, and photographing or observing the light that is reflected. The diagram (Fig. 6) indicates how a concentration of light results from a reflection from a concavity (*a*) and how a reduction or absence of light is caused by a convexity (*b*). The method used was to focus the light from a motor-car head-lamp bulb on to a pinhole 1 mm. in diameter (*P*), from which it diverged onto the specimen. The distance from pinhole to specimen was 40 cm., and a screen (*S*) placed 15 cm. from the tinplate was used to receive the light. The accompanying photographs (Figs. 7, 8, 9 and 10, Plate I) were obtained by attaching gaslight printing paper to the screen *S*. The photographs represent four different samples of tinplate,

¹ Hoare, *J. Iron and Steel Inst.*, 1937, 136, 99 P.

PLATE I.



FIG. 7.

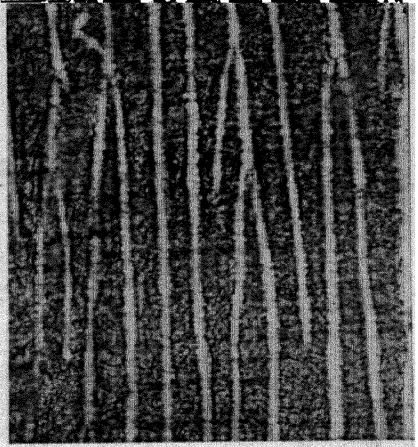

FIG. 8.

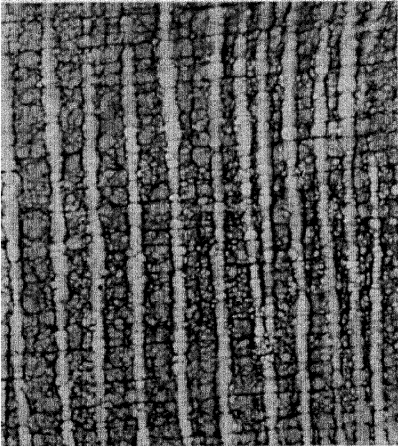

FIG. 9.

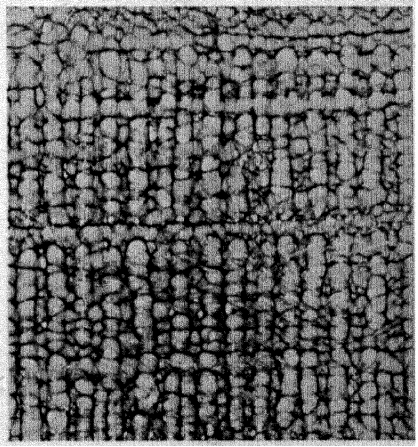

FIG. 10.

Reflection photographs of Samples of Tinplate having different Thicknesses of Tin Coating.

the average thickness of the tin coatings being 2.0×10^{-3} cm., 3.3×10^{-4} cm., 5.3×10^{-4} c. m., 6.5×10^{-4} cm., respectively. It will be observed that the "ridges" referred to above are exhibited by the last three, and that the first specimen carried such a thick coating that the dendritic structure of the tin conceals the ridged effect. It should be noted that the prints obtained are actually negatives of the light reaching the screen. Dark patches on the photographs are regions where the light was a maximum, and *vice versa*. It is suggested by Hoare (*loc. cit.*) that the actual curvature and depth of the depressions on the surface might be measured by moving the screen until the light from the concavities was focused on it. The concavities would then act as concave mirrors and it would be possible to calculate their focal lengths and radii of curvature. This has not yet been carried out.

Crystal Orientation

The reflection of light in accordance with the simple laws mentioned above has found several applications in connection with the study of metallic crystals. The etched surface of a crystal consists of a large number of facets, either forming etching pits or else making up a relatively smooth surface. Light is not reflected from such a surface in a single reflected beam as from a polished surface, but in a number of beams, one corresponding to each set of parallel facets. As the facets invariably occupy definite crystallographic planes, the directions of these planes, and therefore of the crystal axes, can be determined by examination of the reflected light.

In the method devised by Bridgman,¹ and used in his work on the properties of metallic single crystals, the directions of the reflecting facets were determined by a very simple method. A wooden sphere was rigidly attached to the crystal, and the whole was rotated until a set of facets was inclined so that the light from a fairly distant lamp could be seen reflected from the crystal. The point on the sphere from which the light was also reflected was marked. This mark indicated the region where the surface of the sphere was parallel to the set of facets concerned. A mark was made on the sphere for each position in which reflection from the crystal could be seen. The marks.

¹ Bridgman, *Proc. Amer. Acad. Arts Sci.*, 1925, 60, 305.

on the sphere represented the points where the various crystallographic directions of the crystal would intersect the sphere if the crystal were at the centre of the sphere. The relative positions of the marked points showed which axes they corre-

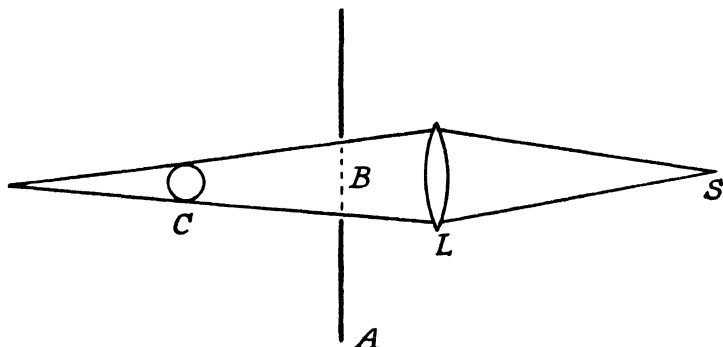

FIG. 11.—Determination of Crystal Orientation.

sponded to, and so the directions of the various axes of the specimen itself were determined.

A second method which utilises the same principle was devised by Chalmers¹ for work on crystals of tin. A slightly converging beam of light from the source *S* (Fig. 11) is directed by means of the lens *L* on to the specimen *C* through a hole in the screen *A*. The specimen is mounted on a goniometer so that its position is determined and so that it can be rotated by any required amount. The axis of the specimen, which is cylindrical, is perpendicular to the plane of the diagram. A number of fairly sharp spots of light are observed on the screen, and the position of each is brought in turn to a fiducial line, marked with a centimetre scale, which is drawn on the screen *A* parallel to the axis of the specimen and passing through the centre of the hole *B*. The distance of the spot from the centre of the hole is measured and the angular position of the specimen is read on the goniometer circle. The angles between the normals to the effective reflecting planes can be calculated from the results and these planes can be identified by comparison of the calculated angles with those deduced from the known crystal structure of the metal. In the case of tin a distinctive pattern of spots, which has been identified by the

¹ Chalmers, *Proc. phys. Soc.*, 1935, 47, 733.

method described, can usually be recognised, and this renders the calculation unnecessary. The approximate position of the C axis can be determined very rapidly by holding the specimen at the position C and turning it until the pattern is centred on the hole in the screen. The C axis then points in the direction CB.

Other applications of the same general method have been used by other investigators, for example, McKeehan and Hoge,¹ but these two examples will serve to illustrate the principle involved.

Investigation of Shape of Surface

A further application of the simple laws of reflection was utilised by Chalmers and Jones² in their investigation of the cause of the striated appearance of hot dipped tinned copper prepared under certain conditions. It was necessary to determine whether the striated appearance was due to the reflection of light from a periodic undulation of the surface, and the procedure was to calculate the shape of surface that would give the same appearance. The specimen was set up under a low-power microscope provided with an eyepiece scale, the magnification being such that two striæ were visible at once. The specimen was illuminated by a single lamp and it was observed that any part of the surface could be made to appear bright by suitably positioning the lamp. The slope of a surface from which the reflection would be similar was calculated for each position of the lamp, and this gave a curve relating the slope of the equivalent surface with position on the surface. A second curve was plotted from this to give the actual shape of the equivalent surface and it was found that the equivalent surface would undulate to the extent of 0.1 mm. from the mean surface. Since this would have been detected by other methods it was concluded that the surface shape was not the cause of the striated appearance.

Crystal Axes by Slip Bands

An application of geometrical optics that may be mentioned here is the method devised by Roscoe and Hutchings³ on the

¹ McKeehan and Hoge, *Z. Krystallogr.*, 1935, **92**, 476.

² Chalmers and Jones, *Trans. Faraday Soc.*, 1935, **31**, 1299.

³ Roscoe and Hutchings, *Phil. Mag.*, 1933, **16**, 703.

basis of an earlier method of Chalmers¹ for determining the orientation of the crystal axes of single crystal wires of metals such as cadmium, which deform by glide along a single type of plane, from a geometrical study of the slip bands formed when the crystal is stretched. The slip bands appear as the intersections of parallel planes with the elliptical cylinder into which the specimen (originally cylindrical) deforms on stretching. From the geometry of the ellipses so formed the original and final orientations can be calculated. In the method of Chalmers, the constants of the ellipse were calculated from the co-ordinates of a series of points on a typical ellipse, an eyepiece graticule being used for determining the co-ordinates. The method was laborious owing to the large number of readings required for an accurate determination. The improved method consists in projecting an ellipse of any desired eccentricity and size to coincide with the image of a slip band. The ellipse was obtained by oblique projection of a circle, the eccentricity of the ellipse being determined from the tilt of the circle relatively to the axis of the optical system. The image of the circle was projected through the vertical illuminator of the microscope with which the slip bands were observed, the reflecting plate being turned so that the reflected beam travelled upwards instead of downwards. A small aperture was used in the vertical illuminator in order to ensure that the whole of the ellipse was in focus.

Optical Reflecting Power

One of the most obvious characteristics of a metal surface is its power of reflecting light and quantitative measurements

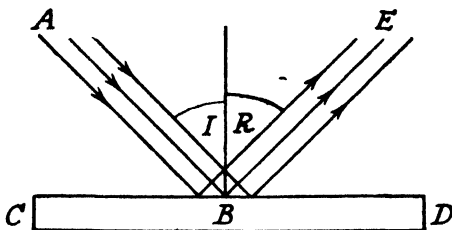

FIG. 12.—Reflection of Light.

of this property have yielded useful information about the changes which such a surface undergoes under various conditions. A parallel beam of light AB (Fig. 12) falling on a metal surface CD undergoes three distinct processes,

the total amount of incident light being divided,

¹ Chalmers, *Phil. Mag.*, 1932, 14, 612.

according to the nature and condition of the surface, into these three parts. In the first place, some of the light is reflected specularly, *i.e.* regularly as from a mirror. This is the part of the light which obeys the simple laws of reflection (angle of reflection equals angle of incidence, incident and reflected rays and normal are coplanar) and is the only part of the light that is considered in ordinary optical theory. It is represented in the diagram by the beam of light BE.

The second process is that of scatter or diffusion, which results in some light reaching points which, according to the optical laws of reflection, should receive none. The difference between the total luminous energy reaching the surface and the total leaving it in these two ways is the amount absorbed; this is often different for different colours, and this causes the characteristic colours of metals such as copper and brass.

Specular and Diffuse Reflection

A perfectly polished surface of a "white metal," *i.e.* one in which there is no selective absorption of one colour, should have a high value for the specular reflection and a low value for the diffuse reflection, the absorption depending largely on the metal concerned. Silver and mercury, for example, have low absorptions while lead absorbs a considerable proportion of the incident light. There is no difficulty in expressing the reflecting power as the ratio of the intensity of the specularly reflected light beam to that of the incident beam, and the absorbing power as the ratio of the quantity absorbed to the quantity incident, but the definition of a coefficient of diffusion is much more complex. For an incident ray making a definite angle of incidence, the diffused light will in general have some intensity at any point in front of the plane containing the metal surface. The distribution of light depends very much on the particular character of the surface, and so the full quantitative description of the diffusing power would necessitate a statement of the intensity of light in every possible direction.¹

Shape of Surface by Analysis of Diffuse Reflection

This aspect has been considered by Canac² who calculated

¹ See, for example, Barkas, *Proc. phys. Soc.*, 1939, **51**, 274.

² Canac, *C. R. Acad. Sci.*, Paris, 1934, **199**, 117; 1935, **201**, 330.

the distribution of light to be anticipated if the reflecting surface consisted of a large number of hemispherical convexities or concavities and attempted to compare this with the actual distribution found when light is reflected from surfaces etched to various depths. Assuming that an etched surface scatters light owing to the presence of microscopic or sub-microscopic irregularities produced by the etching reagent, and that the minute surfaces of these irregularities reflect according to the law of reflection, it should be possible to get some information as to the mode of attack of different etchants on various surfaces by this method. An extreme case is that in which the etch has been carried so far that the facets formed can be used for determining the orientation of the crystal. In this case the reflections are confined to certain definite directions which are accounted for in terms of specular reflection from the etch facets which coincide with certain crystalline planes. (See description of the method, p. 9.)

Scratch on Tinfoil

A suggested application of this effect is for the examination of the extent to which tinfoil is scratched in the cleaning process. A beam of parallel or slightly convergent light falls normally on the tinfoil surface through a hole in a screen and the reflected light is observed on the screen. A band of light of which the length is perpendicular to the direction of abrasion appears on the screen. The distribution of the intensity of light along the band gives a qualitative idea of the amount and character of scratch present.

A similar method has been described by Jacquet¹ in connection with an investigation of his electrolytic method of polishing as applied to copper. This consisted in the photography of the "spot" formed when a narrow beam of parallel light is reflected from the surface under test on to a photographic plate. A sharp, small spot was formed when the surface was smooth and flat, and any imperfection of the surface was indicated in a qualitative manner by a broadening of the image.

Another case in which an incident beam of light is not reflected as a single beam is that of the reflection method of

¹ Jacquet, *Trans. electrochem. Soc.*, 1936, **69**, 629.

examining tinplate that is described above (see p. 8), and although this is not strictly an example of diffuse reflection, it serves to emphasise the fact that there is no hard and fast distinction between regular reflection from a flat surface and diffuse reflection from a surface in which the reflecting units are small and not coplanar. In all these cases, the light, if considered in small enough beams, is reflected regularly from portions of the surface small enough to be considered plane.

Scattering due to Tarnish

Common observation shows that the amount of specular reflection of a surface decreases when a metal surface "tarnishes." It is evident that this decrease of specular reflection corresponds to an increase of diffuse reflection and that the latter is not due to the formation of facets in the surface. It appears, therefore, that the scattering or diffusion that occurs when light falls on a tarnished surface is the result of a different process from that taking place with an etched or abraded surface. The difference may, however, be one of degree only, the opaque particles in the tarnish film possibly reflecting regularly from their surfaces. It is much more likely that such particles scatter the light according to the process that is believed to account for the scattering of light by fine suspensions such as dust or water drops. Ordinary reflection does not occur because the dimensions of the particles are not sufficiently large compared with the wavelength of light and its place is taken by the abnormal or scattering process in which different colours are scattered differently.

Black Stain on Aluminium

An extreme example of this is shown by the "black stain" that forms on aluminium after prolonged contact with hot water. Recent investigations¹ indicate that the apparent blackness is due to an exceedingly fine etching effect. This is equivalent to covering the surface with a layer of very small particles, and the black appearance is attributed to the scattering and absorption of light by these particles. An analogous effect is the black appearance of silver when in a very finely divided state as in a developed photographic negative.

¹ Fischer and Geller, *Z. Metallk.*, 1938, **30**, 192. Anon., *Light Metals*, 1938, **1**, 381.

Measurement of Reflectivity

It will be appreciated, therefore, that while specular reflecting power is relatively easy to measure, its importance is limited because it only indicates the quantity of light that does not undergo scattering or absorption, which are the quantities that really indicate the character of a surface. In spite of this limitation, several very valuable investigations have been carried out by means of measurements of specular reflecting power. The first of these was that of Vernon¹ in connection with his investigations on corrosion. Vernou used the decrease with time of the specular reflectivity of polished metal surfaces as one of his methods of following the progress of the surface reactions resulting in corrosion. Digby² also gives results he has obtained in the same way.

Numerous investigators have made measurements on the

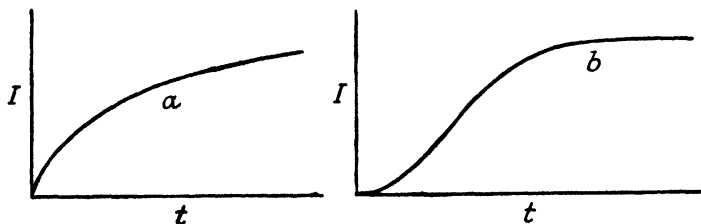

FIG. 13.—Variation of Scattered Light with Time (Canac).

amount of light scattered in a direction making a definite angle with the incident beam which is fixed at a constant angle. An interesting example of this method is the investigation by Canac³ on the tarnishing of various surfaces under different conditions. By illuminating the surface at an angle of incidence of 30° by means of a parallel beam of light, and measuring the light reflected at an angle of 15° to the normal, Canac obtained a measure of the amount of scattering. He found that, according to conditions, two types of curve were obtained. These two types of curve are illustrated roughly in Fig. 13. The two types *a* and *b* were accounted for by assuming that a surface film that scatters an amount

¹ Vernon, *Trans. Faraday Soc.*, 1924, **19**, 884.

² Digby, *Engincer*, 1935, **159**, 219 and 254.

³ Canac, *C. R. Acad. Sci.*, Paris, 1933, **196**, 51.

of light depending on its thickness, may either develop uniformly, starting as a very thin film and approaching asymptotically to a limiting value (this results in a curve of the type *a*) or that the film may start to form at nuclei and then spread outwards from these points until the whole surface is covered. If the "islands" of film grow outwards at a constant rate, the area covered will increase with the square of the time, giving the parabolic shape of the first part of the curve *b*. As soon as the parts of the film from various nuclei meet, however, the rate will slow down and will approach zero as the whole surface becomes covered. These considerations account for the *b* form of curve.

Investigations have also been made in which both regular and diffuse reflection have been measured. Kenworthy and Waldram,¹ working from the point of view of the reflection characteristics required for decorative purposes, point out that a low value for the diffuse reflection is much more important than a high value for the specular reflection, citing black glass, which has good decorative properties, as a case where diffuse reflection is very small but regular reflection is also not large. Providing an image is formed (*i.e.* there is enough regular reflection to be seen) the amount of diffuse reflection is of preponderant importance from the decorative point of view. With a view to classifying reflecting surfaces from this point of view, Kenworthy and Waldram made measurement of both the specular reflection and the diffuse reflection at a definite angle to the normally incident ray. They arrived at an arbitrary figure of merit that involves both the specular reflectivity and the diffuse reflection value given by their method. This figure of merit, however, has no fundamental meaning and should not be regarded as giving more than a very general indication.

The relative influences of specular and diffuse reflections in determining the "brightness" of a surface was also considered by Egeberg and Promisel² who measured the intensities of the specular reflection and of the diffuse reflections at a series of angles when the incident light was inclined at 45° to the

¹ Kenworthy and Waldram, *J. Inst. Met.*, 1934, 55, 247.

² Egeberg and Promisel, *Electrodepos. tech. Soc.*, 1937, 13, 11 pp.

surface. These investigations found that the "brightness" could be expressed by the formula.

$$B = \frac{100 (S - D_0)^a}{S + D}$$

where B is the "brightness"

S ,, ,, intensity of the specular reflection

D ,, ,, sum of the intensities of the diffuse reflections
measured at intervals of 5° between the
specular direction and the normal

D_0 is the intensity of the diffuse reflection along the
normal

and a is a constant.

A formula such as this does not of course represent any easily definable physical quantity, but it is stated that the order in which a series of surfaces are placed by this criterion agrees with the order in which they would be placed by expert judgment. It may be pointed out, however, that the comparison of surface finish by a formula of this type involves the assumption that the property under consideration, namely "brightness," can be represented by a single figure. This probably only holds with any accuracy when the surfaces that are to be compared are produced in a similar manner, so that the angular distribution of the reflected light has similar characteristics. In the present case the series of surfaces under examination were all produced by electrodeposition, and the curves relating diffuse reflection with angle were all of the same type.

The method used for the determination of these curves was to compare the apparent brightness of the surface with a standard field of which the brightness could be varied at will. This appears to give quite satisfactory results when employed by an experienced observer, but it is doubtful whether it would prove reliable in untrained hands. A method in which the measurement of the light intensity is made by means of a photo-cell seems to promise more consistent results. The technique of such measurements as those mentioned above has changed to keep pace with developments in photometry. With the introduction of the photoelectric cell as a reliable

instrument for measuring light, the older forms of photometer are rapidly going out of use. Vernon (*loc. cit.*) used the Lummer Brodhun photometer, of which a description will be found in Watson's *Practical Physics* (Longmans), and Kenworthy and Waldram (*loc. cit.*) also used a visual instrument. Digby¹ describes his use of a photoelectric method, while Portevin² points out the advantages of an objective absolute method in an article on "The Photocell and its Use in the Measurement of the Brilliance and Colours of Metals."

The use of a photocell for measuring the intensity of light necessitates an instrument for measuring the electrical output of the photocell. The choice of this instrument is largely governed by the sensitivity of the photocell used, and suitable circuits and apparatus are recommended by the manufacturers of the photocells.

Practical Considerations

From the optical point of view the following practical points should be observed. The main consideration is that light which has not come in the required direction from the part of the surface under examination must be rigidly excluded. This is a matter that must be determined by the particular details of an investigation. Secondly, the lamp used as a source of light must not be assumed to be of constant brightness, because the filament does not remain constant in its properties, and the voltage of the supply from which the lamp is run may not be steady. It is necessary, therefore, to standardise frequently by allowing light to reach the cell directly from the lamp, as well as measuring the light reaching the cell *via* the specimen. It is necessary, for absolute measurements, to make this comparison so that the cell is the same distance from the lamp in both cases (*i.e.*, so that the distance travelled by the light does not change).

In order to determine the absolute reflectivity of a surface it is necessary to compare the light reaching the photoelectric cell P (Fig. 14) from the lamp L by reflection from the surface S with the light reaching P from the same direction if the lamp is placed at L', *i.e.*, at the position of the image of L in the

¹ Digby, *Engineer*, 1935, **159**, 219 and 254.

² Portevin, *Rev. Alumin.*, 1934, **61**, 2409.

mirror S . It is necessary for the surface S to be large enough for the whole of the image of the bright source L to be seen from every point on the sensitive surface of the photocell P . If the source is too large in relation to the polished surface, a circular aperture can be introduced in front of L to reduce the effective size of the source. A much more convenient method, however, is to compare the reflectivity of the surface under examination with that of a standard surface. An example of this method is described on p. 22.

Similar considerations apply, with necessary modifications, when diffuse reflection is being measured instead of specular

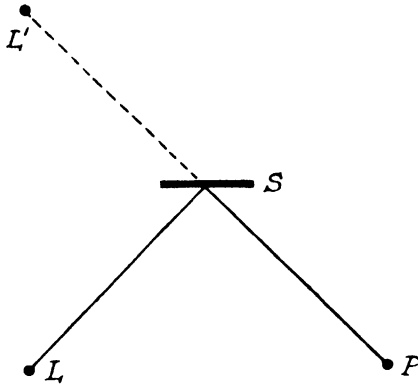

FIG. 14.—Arrangement of Apparatus for Absolute Measurement of Reflectivity.

reflection. Since, as has been pointed out above, there can be no single figure which expresses the diffuse reflectivity of a surface, experiments can only be comparative, and the particular conditions under which a figure representing the diffuse reflectivity is obtained must depend upon the purpose for which the measurements are made. For a series of comparable observations the following conditions must be maintained constant: (1) brightness of source, (2) distance of source from reflecting surface, (3) area of reflecting surface, (4) angle of incidence, (5) position of photocell. If one surface is replaced by another, all other conditions remaining constant, then the ratio of the amounts of light received by the photocell is equal to the ratio of the diffuse reflections at the angles employed.

The fact that, when a metal surface is illuminated with white light, the reflected light is not always white may cause considerable confusion when the reflectivities of such surfaces are being compared. The difficulty is due to the indefiniteness of the term "amount of light" as used in the working definition of reflecting power given above. The expression may mean luminous energy, either within the visible spectrum or including infra-red and ultra-violet radiations or it may mean subjective brightness, which depends on the estimate of optical sensation in the eye. Since the eye is most sensitive to the yellow part of the spectrum, it follows that light of a yellowish colour will appear brighter than red or blue light of the same intensity as defined from the energy point of view; and since the colour response varies with the characteristics of the eye, two observers would not necessarily agree as to which is the brighter of two lights of different colour. Thus methods which depend on visual photometry may not yield consistent results when practised by different observers. Two alternatives present themselves for avoiding this ambiguity. Since light of any colour can be produced by mixing together three primary colours in suitable proportions, it may be seen that by measuring the reflectivity of red, blue and yellow light, something approaching a true description of the reflecting power may be obtained. Such figures are not, however, absolute unless the filters used for obtaining the colours are standardised as regards their transmission characteristics. An extreme example of this is the case of copper, which strongly absorbs blue light (hence its characteristic colour). This is due to the absorption of a comparatively small part of the blue end of the visible spectrum. If the trichromatic reflectivity described above is carried out using blue light of a small band of wavelengths, the reflectivity for blue light might be found to be very small. But if a wider band of blue light having its centre and maximum intensity at the same wavelength as before is used the reflectivity for blue would be increased considerably. To the eye, the two blues would appear much the same, and their difference only appears when the light is analysed spectroscopically. The second method is to use a photocell with a white source of light and to regard the characteristic curve of the photocell,

relating wavelength with response, as the standard. The results would probably not agree with those obtained visually by any observer, because the response curve of a photocell is usually different from that of the eye; but the photocell readings would be definite and reproducible.

A considerable amount of work has been done in recent years on methods of preparing reflecting surfaces that retain their reflectivity when exposed to atmospheric or other corrosive conditions. In some of these experiments a visual estimate has sufficed to reveal the differences in permanence of surfaces treated in different ways.¹ In other cases it has been found necessary to make a definite measurement of the reflecting power and its variation with time. As an example of this type of experiment, the work of Pullen² can be considered. A distinction which seems useful is drawn between a "mirror" and a "reflector"; the former should have a high reflectivity and low diffuse reflection and the latter *vice versa*. In order to test the value of a process in which a good reflecting or mirror surface is produced on aluminium and is protected with an oxide film, Pullen measures both the specular and diffuse reflections after various times of exposure to various atmospheres. His method is to project a beam of light from a 100-watt lamp on to the surface (which is inclined at 30° to the beam of light), and to focus the reflected light on to a Weston Photronic Cell which is connected directly to a low resistance microammeter. In order to avoid errors due to changes in the light output of the lamp, caused by variations in the mains voltage or in the lamp itself, this is standardised, by means of a rheostat, to give a definite response when a standard reflector of silver is in position.

An interesting investigation on the effect of the composition of an alloy on its reflection coefficient was carried out by Bergmann and Guertler,³ who extended the scope of earlier work on the same lines. The experiments were designed to determine how the selective absorption of copper which is responsible for its characteristic colour is affected by alloying

¹ *E.g.*, Price and Thomas, *J. Inst. Met.*, 1938, **63**, advance copy.

² Pullen, *J. Inst. Met.*, 1936, **59**, 151.

³ Bergmann and Guertler, *Z. tech. Phys.*, 1935, **16**, 235.

with nickel. Using copper-nickel alloys ranging from 0 per cent. to 100 per cent. nickel, and wavelengths from 4670 Å to 6100 Å, it was found that the selective absorption of copper disappears when the nickel content reaches 25 per cent., the reflectivity being the same as for pure nickel for the alloys from 25 per cent. to 100 per cent. nickel. This change, which occurs gradually with increasing nickel content and is complete at 25 per cent. is not apparently related to any other change of physical properties of the copper-nickel alloys.

Importance of Reflection Characteristics in Metallography

From a rather more general point of view, the reflection characteristics of a metal are of the greatest importance in the microscopical examination of metals. The process of etching, which is usually intended to make it possible for different phases or different crystallites to be distinguished from each other, may affect the surface in several different ways. These may be classified as (*a*) by revealing the crystal boundaries, (*b*) by emphasising differences of orientation of the crystals present, and (*c*) by distinguishing between regions of different composition. These three processes all depend on the alteration of the reflection characteristics of the metal as the surface layers are dissolved away. The change may be due (*a*) to the formation of "grooves" or "furrows" at the crystal boundaries, in which case the brightness of the boundaries is reduced because the surface is altered so as to be less favourably oriented for reflecting light into the microscope; (*b*) to differential attack, due to the crystal structure, which produces definite etch facets that reflect the light in particular directions, so altering the amount of light which is seen in the microscope, and (*c*) to the reduction of specular reflection by general attack of the surface, the effect generally being due to increased absorption caused by general roughening, or else to an increase of its scattering power, often in such a way that a definite colour results. Thus the phases present, or else the individual crystals, may be distinguished from each other by the amount and colour of the light which is reflected from them into the microscope.

Fluorescence

While it is generally true that the colour of a surface is due to the fact that some of the light reaching it is absorbed and the remainder is reflected, there are certain cases in which the colour is caused in a different way. Fluorescence and phosphorescence are examples of this action, and since fluorescence has been shown to be a potentially valuable adjunct to the ordinary metallographic technique, it is proposed to discuss it here. The process of fluorescence is that in which a substance gives out visible light when the only radiation falling on it is in the ultra-violet part of the spectrum. The fluorescent light is always of longer wavelength than the radiation from which it results. In many cases the light is still emitted for a time after the ultra-violet radiation has been cut off, and this phenomenon is known as phosphorescence. The fact that some substances fluoresce while others do not, and that different substances have different fluorescent colours, has been used by Mitsche¹ for detecting very small inclusions in metals. The first case investigated was that of alumina in aluminium and its alloys, the alumina being present in the form of particles that were too small to be detected by ordinary microscopical observation. Using, in his first experiments, an apparatus designed by Haitinger,² and later one of his own design, Mitsche found that alumina fluoresces with a blue colour when irradiated with ultra-violet, and that aluminium does not. This formed the basis of the method, but careful control was necessary before it could be applied, the main difficulties arising from the possibility of the polishing material becoming embedded and being mistaken for alumina, and the possibility that alumina prepared in various ways would not fluoresce in the same manner. These obstacles were overcome by a series of carefully designed experiments in which alumina prepared and treated in four completely different ways was found to give a consistent blue fluorescence, which varied only in shade according to the orientation of the grains. Some trouble was caused by the polishing medium when the surface under examination

¹ Mitsche, Carnegie Schol. Mem., 1934, **23**, 65; 1936, **25**, 41; *Berg-u. hüttenm. Jb.*, 1938, **86**, 12.

² Haitinger, *Mikrochemie*, 1930, **9**, pp. 220, 430.

was of a porous character. The polishing material used (Sidel, Messrs. Vieger, Vienna) also gave a blue fluorescence, but it could be distinguished from alumina by the use of morin; if the surface is wetted with morin, particles of sidol give yellowish brown fluorescence when wet and practically no fluorescence when dry, but alumina shows yellowish brown fluorescence both wet and dry. Thus the blue fluorescence which persists with its colour changed to yellowish brown after treatment with morin, was a definite indication of alumina. The distribution of alumina in the surface could of course be ascertained from the arrangement of the blue points that could be seen under conditions giving rise to fluorescence.

Further work by Mitsche¹ has shown that this simple technique for detecting the presence of inclusions is of very limited application. In general, metals and their inorganic salts do not fluoresce, although there are a number of exceptions to this rule. It is sometimes possible to convert an inorganic salt into an organic one which fluoresces, or to make the inclusions absorb a fluorescent material, but these methods have not so far been developed very fully. The detection of other inclusions that are too small for microscopic observation has also been considered by Mitsche in connection with his work on the effect of inclusions on crystallisation. He found that oxide inclusions could sometimes be detected by acting upon the surface with a suitable reagent which became fluorescent if the metal contained inclusions. In an attempt to detect Fe_2O_3 , FeO , MnO and CuO , Mitsche found that acetic acid acquired a milky white fluorescence in the presence of Fe_2O_3 , and that formic acid fluoresced fairly strongly when it had been in contact with Fe_2O_3 , not at all with FeO , slightly with MnO and slightly after it had been in contact with CuO for three weeks.

It will therefore be appreciated that the method of analysis by fluorescence has already been used for observing inclusions that could not be detected under the microscope in ordinary conditions, and for proving the presence of oxides where there was no other evidence for their presence. It is quite possible that a series of reagents could be developed which would make

¹ *Loc. cit.*, 2nd and 3rd papers.

it possible to detect and identify the inclusions present in iron and steel and other materials.

Total Reflecting Power

From a theoretical point of view, it is of interest to determine the total reflecting power of a surface rather than to distinguish between the specular and diffuse effects. The difference between the total reflecting power and unity (which represents the ideal reflection) is the absorbing power, and this, as is mentioned below (see p. 162), is closely related to the radiating power. Thus a black body has a total reflecting power of zero, absorbing power unity and radiating power a maximum. The total reflecting power of a surface could be found by the complicated process of measuring the amount of light reflected in every direction when a beam of light is incident on the surface in a definite direction. Summation of these quantities for all directions would give the total amount of light reflected and the total reflecting power would follow.

It was proved by Hamaker,¹ however, that this process could, in effect, be reversed, and that if the surface were illuminated by homogeneous light reaching it from all directions, the intensity of the light leaving it in one particular direction gives the total reflecting power corresponding to light arriving from that direction. The very much simpler technique resulting from this theorem was applied by Ornstein and van der Veen² and by Ornstein and Koefoed.³ For the experimental method, which was devised for experiments on the total reflecting power of iron at temperatures in the neighbourhood of the Curie point, *i.e.*, 1040° C. for iron, the reader is referred to the original papers. The experiments of Ornstein and van der Veen were carried out on iron, and those of Ornstein and Koefoed on nickel and on an alloy of iron and nickel. The specimen, in the form of a strip 3 mm. wide and 30 μ thick, was mounted *in vacuo* in a glass bulb and heated electrically, readings being taken, in the experiment on iron, at temperatures from 900° K. to 1200° K. The specimen is placed at the centre of a sphere 50 cm. in diameter, painted white internally, and illuminated

¹ Hamaker, Thesis, Utrecht, 1934.

² Ornstein and van der Veen, *Physica*, 1936, 3, 289.

³ Ornstein and Koefoed, *Physica*, 1935, 3, 175.

by two lamps (screened from the specimen) near the centre. The light reflected from the specimen is focused on the slit of a monochromator (*i.e.*, spectrometer arranged to separate one wavelength from the rest of the spectrum) and the light of the wavelength chosen (6500 Å) is measured by means of a photocell. In order to calculate the total reflectivity it is necessary to know the intensity of light falling on the specimen, and this is determined by removing the specimen and measuring the light received from the opposite side of the sphere. Corrections were applied for light absorbed by the glass bulb containing the specimen, for the radiation of the specimen itself due to its elevated temperature, and for non-uniformity of illumination of the sphere. An optical pyrometer was used for measuring the temperature. This is justified by the investigators on the grounds that it determines the surface temperature, and that this is what is required in view of the fact that a surface property is being investigated. It may be pointed out, however (see p. 162), that the optical pyrometer only gives the "black body" temperature, *i.e.*, the temperature of a black body which radiates similarly to the surface investigated, and that a black body is a full radiator and does not reflect at all. It is therefore inconsistent to use the black body temperature and to regard it as correct when there is an appreciable reflecting power. Corrections for the departure from the black body condition could be applied, using the reflecting power data to indicate the extent of the difference. In spite of the difficulty inherent in measuring the surface temperature of a reflector, Ornstein and van der Veen obtained results for iron which showed that the reflectivity increases from about 62 per cent. at 1000° K. to about 66 per cent. at 1100° K., this change taking place not quite reversibly with temperature over the range in which the magnetic transformation point (Curie point) lies. It is not to be concluded from this result that every transformation or phase change is accompanied by a change of total reflecting power, because the same investigation showed that there was no observable change of the reflecting power at the β - γ change at 1180° K.

Optical Properties of Thin Films

The foregoing discussion of the reflection of light has been confined to the study of the reflection from the surfaces of metals in bulk, *i.e.*, in the form of plates thick enough to be opaque. Certain optical properties will be considered in this section in connection with films of metal that are thin enough to transmit a portion of the light which falls on them.

The examination of thin films by means of the electron diffraction technique has given a great deal of information about the crystal structure of such films. It was pointed out by Andrade and Martindale,¹ however, that a very considerable heating effect occurs during electron diffraction examination, and that this may so modify the film that its original properties are not revealed. It is therefore apparent that a study of the structure of films by electron diffraction methods should be preceded by an examination by a method that does not cause sufficient local rise of temperature to modify the film during an experiment. In this way it is possible to determine the effect of elevated temperatures and to decide on the value of the information supplied by the other method. It may be pointed out that, owing to the extreme tenuity of the films under consideration, their rate of heating under the bombardment of an electron beam would be rapid; the thermal capacity per unit area is small, and the lateral conduction of heat away from the heated spot would be slow.

Effect of Heating

A number of investigations on thin films by optical methods have, therefore, been designed to reveal the changes that take place when such a film is heated. The most important early work on this subject, that of Faraday,² was undertaken when optical examination was the only method of investigation; his results on the changes in the optical properties of gold and silver leaf on heating must still be regarded as standard work. The experiments of Faraday were carried out on gold and silver leaf prepared by beating down sheets of gold in the way that is still used in the manufacture of gold leaf, as well as by chemical means. Films formed in these ways are not

¹ Andrade and Martindale, *Phil. Trans.*, 1935, 255, 69.

² Faraday, *Phil. Trans.*, 1857, p. 145.

under exact control as regards thickness, and may be in a state of extreme cold working. They are therefore special cases, and may be expected to behave differently under annealing conditions from films prepared in other ways. More recent investigations have been largely confined to the study of films produced by condensation or by cathodic sputtering. These two methods, while bearing a slight outward resemblance, are in fact completely different. In the condensation method, the metal is heated electrically to a high temperature in an evacuated space which also contains the surface on which the film is to be formed. A high vacuum is essential and the metal which evaporates from the heated filament condenses on cool surfaces in the neighbourhood. The other method, that of cathodic sputtering, consists in passing a discharge of electricity from an anode of the metal of which the film is to be formed to a cathode which supports the plate on which the film is required. A fair, but not high, vacuum is required in order that the discharge will pass. The cathode can be kept cool by a flow of water through it,¹ and the thickness of the film which depends on the current, time, distance between anode and cathode, and on the gas pressure in the vessel, is under complete control. At the same time it should be realised that the film is formed under conditions in which atoms or molecules of the residual gas may be trapped in the film.

Of the numerous investigations that have been made on films prepared in these ways, it will be sufficient to give an account of the following, which include the most important examples. The change of intensity of a beam of light transmitted through a sputtered film of gold and silver when the film was heated to various temperatures for various times was investigated by Rama Swamy² who made measurements of the absorption of light by thin films of gold and silver before and after heating. Since the chief interest attaches to the colours that characterise the light transmitted by these films, Rama Swamy measured the absorption of the films for various wavelengths. The light which was transmitted by the film

¹ Andrade and Martindale, *loc. cit.*

² Rama Swamy, *Proc. roy. Soc.*, 1931, **131**, 307.

was photographed after passing through a prism, which caused the light to be dispersed into a spectrum. The relation between absorption and wavelength was determined from a photometric examination of the spectra so obtained. Films of gold, appearing green and blue-green, and of silver (blue and violet), were examined in this way, the gold films being heated to 600° C. and the silver to 400° C. before the spectra were again photographed. The explanation proposed by Maxwell Garnett¹ for the colours of films of this type is based on the different way in which light of different colours is scattered by particles which are small compared with the wavelength of light. The changes of colour that were observed by Faraday and others when the films were heated were measured by Rama Swamy, who showed that if the effect of heating were to cause the film to break up into isolated or nearly isolated "globules," Maxwell Garnett's theory would account for the changes of colour. Certain assumptions as to the rate of growth of these globules and the space between them are necessary in order to get complete agreement between the theory and the experimental results. Details of these assumptions will be found in the paper referred to. The conclusions regarding the agglomeration of the film into particles were confirmed by microscopic examination and by measurement of the electrical resistance, which gave definite evidence of the lack of continuity of the film after heating. This work was followed up in much greater detail by Andrade and Martindale,² who made a microscopic investigation of the changes that take place in films of gold and silver 30 to 100 atoms thick under various heat treatments. Three methods of examination were used, namely (1) by transmitted light, (2) by dark ground illumination and (3) by polarised light (transmitted). The results, briefly, are as follows. The film is at first quite uniform as far as can be ascertained microscopically. The first effect of heating, *e.g.*, silver, for 1 hour at 230° C., is to cause the appearance of thickened particles of the order of 10^{-4} cm. in diameter. The space surrounding the particles is not completely cleared of film, which remains continuous but more transparent than

¹ Garnett, *Phil. Trans.*, A 203, 1904, 385; 205, 1905, 237.

² Andrade and Martindale, *loc. cit.*

before. This process must be regarded as the first stage in the formation of crystals. The thickened particles are regarded as embryo crystals and these were examined by polarised light under crossed polariser and analyser (see Chapter 5). The particles showed an "extinction cross" which rotated with the polariser and analyser but not with the specimen. Two possible explanations of the extinction cross are offered; one is that the first material to add itself to a nucleus in the formation of a crystal is subject to abnormal conditions which cause it to be doubly refracting, in such a way that the radius of the circle is at any point in the plane of polarisation of one of the two rays into which incident light would be resolved by double refraction. In this case, no resolution of the incident ray would occur in, or perpendicular to, the plane of polarisation of the incident beam (Fig. 15). Extinction would therefore occur in these two directions AB and CD only. This type of particle is known as spherulitic, and examples are definitely known in fields other than the one under consideration. The supposed type of growth, in which the planes of polarisation are radial and tangential, is rather difficult to reconcile

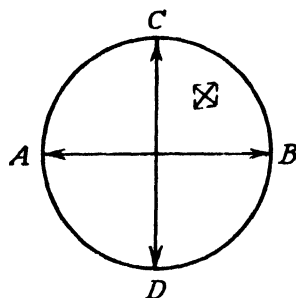

FIG. 15.-- Extinction Cross in "Spherulets."

with the cubic crystal lattice to which the crystal has eventually to conform. The other suggested explanation, and perhaps more likely one, is that the particles, spherical in shape, give rise to the extinction cross by transmission in a manner similar to that discussed later in connection with the identification of inclusions in steel.¹ For safety, the particles are referred to by the authors of the paper as "spherulets."

Further heating at higher temperatures causes the particles to grow, and increases the size of the "windows" or clear spaces. The extinction cross is now absent except for traces that are still visible at the edges of the particles. This seems to support the view that the cause is an internal reflection effect. At still higher temperatures, further crystals form in

¹ *Vide infra*, p. 152.

the parts of the film that remain, and the crystals become large enough to exhibit definite crystal faces. It is apparent that the original film is not crystalline in structure, since a definite process of crystallisation has to take place before the actual crystals are found. It is probable, therefore, that the film is originally amorphous. This has not been confirmed by the electron diffraction method of investigation, possibly for the reason mentioned above. The experiments of Andrade and Martindale are therefore concerned chiefly with the process by which a film may crystallise under suitable conditions. Other investigators have studied other aspects of the nature of thin films. Smoluchowsky,¹ for example, reports that the absorption of light by thin gold films formed by condensation on glass is a rather complicated effect, showing a series of maxima and minima that do not appear in the results of Rama Swamy's work. Smoluchowsky explains his results in terms of the "graininess" of the surface of the film. From the details available, however, it does not appear that this phenomenon is a general property of gold films.

Mode of Formation of Films

The foregoing experiments were concerned with the examination of films that had already been formed, and give no evidence regarding the process by which the film reaches its final condition. The experiments of Starkey,² on the other hand, were made on films while they were forming. The reflecting power of films formed by condensation on surfaces cooled with liquid air was measured at various stages of the deposition of the film. The light reflected from the surface was measured by means of a photocell, a constant source of light being used. Starkey concluded that when the film starts to form the atoms or molecules which condense on the surface migrate to nuclei, with the result that the film grows outwards from such nuclei until the various portions of the film meet and the whole surface is covered.³ The film subsequently thickens, presumably by adhesion of the atoms where they reach the film. It would be interesting to know whether the "spherulets" examined by Andrade and Martindale form at the same points

¹ Smoluchowsky, *Phys. Rev.*, 1936, **49**, 649.

² Starkey, *Phil. Mag.*, 1934, **18**, 241.

³ Cf. p. 16.

as the original nuclei from which the film grows, assuming that the sputtered films studied by these investigators follow the same mode of formation as the condensed films of Starkey. It will be appreciated that the thin films dealt with in this section are considerably thinner than the films which show interference colours, which are dealt with in Chapter 3.

Another interesting type of experiment, on which more work could be undertaken with advantage, is in connection with the changes which films undergo during the period immediately following their formation. Edwards and Petersen¹ measured the reflection and transmission characteristics of thin films of aluminium and magnesium formed by condensation *in vacuo*. They found that these properties are subject to three changes, each of which consists of a decrease in reflectivity and an increase in transmissivity. The first change takes place during the first minute, after which no further change occurs so long as the vacuum is maintained. When air or nitrogen is admitted, a further change takes place, the rate depending on the rate at which the gas is admitted. It is followed by a slow change, the two properties approaching final values asymptotically. An example quoted in the original is that a film originally possessing a reflecting power of 58 per cent. shows changes of 8 per cent., 5 per cent. and 10 per cent. respectively for the three types enumerated above. The transparency of metallic films to ultra-violet light has been studied by Hartzler,² who prepared the metal films by condensation on very thin celluloid discs, prepared by a special technique which is described in his account of the work. The films were of thicknesses ranging from 100 Å to 1000 Å, and a vacuum prism spectrograph, with optical parts of fluorite, was used. The transmissions of light of wavelengths 4300, 3100, 2000 and 1608 Å, were calculated from measurements of the densities of the lines of these wavelengths in the photographs of the spectra taken through the films. The percentage transmission of each of these wavelengths was determined for various film thicknesses for a number of metals with which uniform films could be obtained.

Reference should also be made to a method devised by

¹ Edwards and Petersen, *Phys. Rev.*, 1936, **49**, 207.

² Hartzler, *J. opt. Soc. Amer.*, 1934, **24**, 339.

Ornstein¹ for measuring the transmission and reflection of thin films produced by evaporation. The method, which employs a spectral pyrometer, is useful in the infra-red region as well as in the visible spectrum, and is well adapted for use at high temperatures.

¹ Ornstein, *Trans. Faraday Soc.*, 1935, **31**, 1158.

CHAPTER 3

WAVE OPTICS. I: INTERFERENCE

The wave theory of light not only accounts for the laws of reflection and refraction, but also explains other properties such as interference and diffraction that are inexplicable by the geometrical method.

In order to understand the various effects attributed to the wave nature of light, it is necessary to accept the primary concept that when a point in the aether is disturbed, it gives out a spherical wave, just as when a stone is thrown into a pond of still water a circular wave spreads out over the surface of the water. Consequently, if a plane wave front occupies a

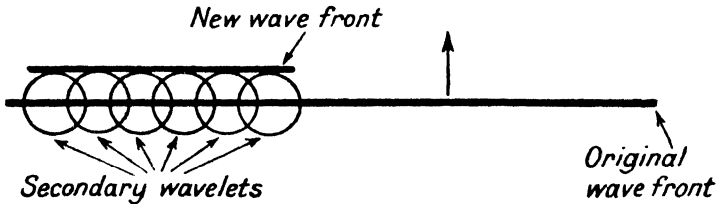

FIG. 16.—Propagation of Light.

given position at a given instant, every point on that wave front then gives rise to a spherical wave (or a secondary wavelet) spreading out in all directions. The result is that all these secondary wavelets combine to produce the effect which exists a moment later (Fig. 16). It can be shown that the crests and troughs of the various waves cancel each other except along a new wave front parallel to the old one. (It should be mentioned that considerable difficulty has been encountered in explaining why the wave does not also travel backwards.) Hence the wave theory accounts for the propagation of light in straight lines. Explanations of reflection and refraction follow on similar lines, but from the present point

of view it is of more interest to consider what happens if various parts of the wave front are separated from each other and then recombined after following different paths.

Interference

Let us consider the case in which a beam of light is divided into two parts by partial reflection at a surface, the two parts being recombined after following different paths. The simplest example is that in which a ray NP (Fig. 17) is partially reflected as PQ by the surface AB , the remainder of the incident light being refracted as PR . The second surface CD also reflects some light along the direction RS . These rays represent the directions in which waves are travelling. The intensity of the

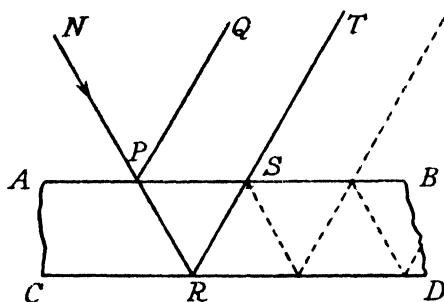

Fig. 17.—Partial Reflection causing Interference.

light that results from the simultaneous reception of the waves represented by PQ and ST will be considered. The effects of further reflections at S , etc., will be considered when the process is dealt with in more detail.

The combined effect of PQ and ST depends upon the relation between the phases of the waves. If the waves are in phase, the two waves add together to produce a maximum intensity; but if they are out of phase, the “crest” of one coinciding with the “trough” of the other, then the two waves will tend to cancel, the relative strengths determining whether the cancellation is complete. For intermediate phase relations the cancellation will be partial. The two extreme cases are illustrated in Fig. 18. The phase relations of the two rays will depend on the distance travelled by $NPRT$ in excess of that travelled by NPQ (Fig. 17). If this difference is equal to one or more complete wavelengths (λ) of the light used

in the medium occupying the space between the reflectors, then the rays, which were in phase at P before reflection, will be in phase again after reflection.

A complication has to be considered here for which no satisfactory explanation can be attempted in this book. The above conclusion, *i.e.*, that a path difference of one wavelength results in re-enforcement of the waves, should apply to any whole number of wavelengths in which zero should be included. Thus a film of zero thickness should reflect light at maximum intensity, and, as will be explained later, transmit at zero intensity. This is of course not the case, and it is necessary

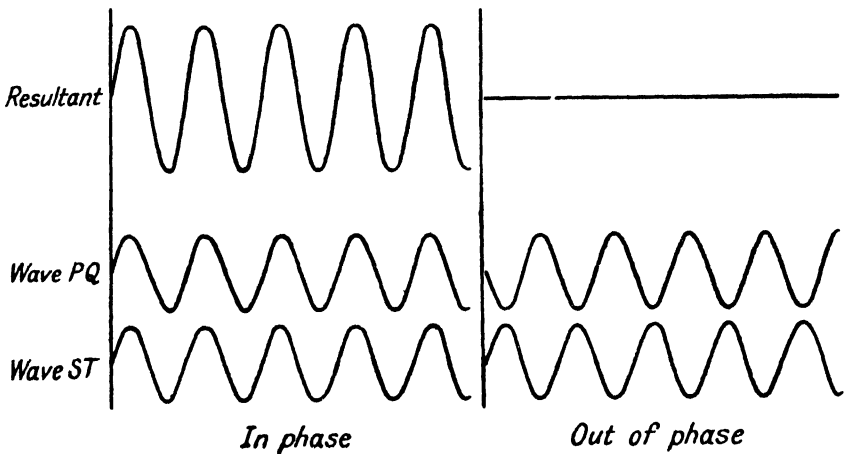

FIG. 18.—Effect of Phase on the Resultant of Two Waves.

to postulate that the phase relation of the two rays is changed by half a period when the rays are reflected from the two reflecting surfaces, *i.e.*, an extra path difference of half a wavelength must be added to the actual path difference. Therefore if the path difference is $\lambda/2$, $3\lambda/2$, $5\lambda/2$, etc., the reflected light has a maximum intensity, and if it is 0 , λ , 2λ , etc., it has a minimum (the intensities of the maxima and minima will be discussed below).

If the surface CD transmits some of the light that falls on it, then the light transmitted by the system will be subject to conditions similar to those affecting the reflected light. The two rays concerned are now RX and WZ (Fig. 19); if they are out of phase the intensity will have a minimum value,

and if they are in phase, a maximum value. But in this case the path difference to be considered is the actual path difference, the extra half-wavelength not entering into the calculation. The reason for the difference between the cases of reflected and transmitted light lies in the fact that with transmitted light the two reflections (at R and S) are both in the same medium, *i.e.*, the medium that occupies the space between AB and CD, while in the case of reflected light, one reflection is in this medium and the other is in the medium which occupies the space above AB. If one type of reflection (it does not matter which) causes a phase change equivalent to

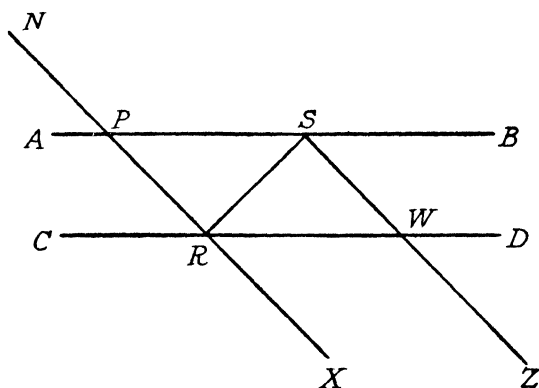

FIG. 19.—Conditions for Interference of Transmitted Light.

an extra half-wavelength of path, the difference is accounted for. The actual cause of this phase change need not be discussed here, although further reference to the subject will be made in connection with the colours of thin films.

In order to avoid confusion when different types of interference effects are under discussion, it is as well at this stage to define two sets of conditions that are used for interferometric measurements, and to differentiate between them. For simplicity they will be referred to as parallel plate systems and inclined plate systems.

Parallel Plate Systems

Consider two exactly parallel surfaces (Fig. 20), each of which reflects some of the light that falls on it and transmits the rest. The light that is transmitted will consist of a

number of rays of which the most important are the direct ray SCA and the reflected ray SCDB. These rays will re-enforce if their path difference is zero, λ , 2λ , etc., and will tend to cancel if it is $2\lambda/2$, $3\lambda/2$, $5\lambda/2$, etc. Thus the combined effect of the rays SA and SB will depend on the distance between the reflecting surfaces and on the angle which the rays make with the normal. If, as stated above, the plates are exactly parallel, all the light passing through them in a given direction will be acted upon in the same way, and if the eye is focused on the plates from a distance, they will appear light or dark according to the phase difference. If, however, the light passing through the plates is observed in a telescope focused for infinity, a series of bright and dark rings will be seen in the telescope. This is due to the action of the objective of the telescope in focusing at a single point of the image all the rays that reach it parallel to a given direction. This is illustrated in Fig. 21, in which it will be seen that all the rays parallel to OA are concentrated at A.

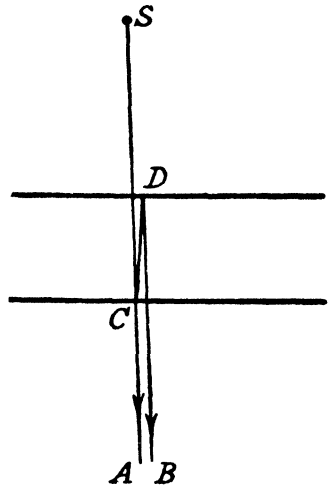

FIG. 20.—Parallel Plate System.

This is due to the action of the objective of the telescope in focusing at a single point of the image all the rays that reach it parallel to a given direction. This is illustrated in Fig. 21, in which it will be seen that all the rays parallel to OA are concentrated at A.

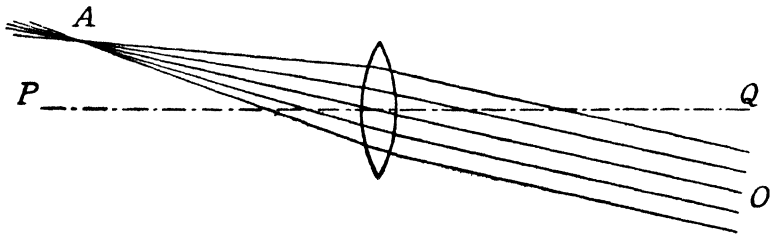

FIG. 21.—Effect of Telescope.

All rays making the same angle with the axis PQ of the telescope will therefore be focused on a ring of which A is one point. Therefore all the rays for which the path difference is the same (owing to their equal inclination to the plates) will form a ring in the field of the telescope. As the angle with

the normal to the reflecting plates is increased, the path difference increases, and the field of the telescope will consequently show a series of concentric fringes or rings which are alternately of maximum and minimum intensity. If white light is used, the different wavelengths corresponding to the various colours cause the rings of the different colours to be formed in different places. The result is that a confused series of coloured rings is seen ; a source giving light of one colour only is therefore used for measurements. Light of a single wavelength, *i.e.*, monochromatic light, can be obtained either by passing white light through a prism and selecting a single narrow band of colour from the resulting spectrum, or else by selecting a single colour from a source of light that gives out only a few very narrowly limited colours. The latter method is used almost exclusively for this purpose, the most convenient sources of light being mercury, sodium and cadmium discharge lamps. The reasons for choosing one or other of these for specific purposes will be discussed later.

When monochromatic light is used, therefore, the field of the telescope shows a series of circular fringes. Relative movement of the two surfaces so that they remain parallel but change their separation causes these rings to expand with the formation of new ones at the centre, if the separation increases, and to contract with the disappearance of the rings as they reach the centre, if the separation is reduced. Every time the separation changes by half a wavelength, the path difference changes by one wavelength and the fringe system moves so that each fringe reaches the position previously occupied by the neighbouring one. This method of measurement has been applied to a metallurgical problem by Phillips and Pollard.¹ In an investigation of the indentation of metals by hard spheres, the pressure was applied between the two rings A and B (Fig. 22), separated by the three steel spheres, of which only two, P and Q, are shown in the diagram. The indentation caused by the pressure resulted in a reduction of the separation of the rings. This was observed by a transmitted light parallel plate system, one plate being attached to the upper ring and the other to the lower one. This is a

¹ Phillips and Pollard, *Engineering*, 1937, 339.

particularly suitable case for the application of the method because no relative motion of the rings is possible except that which is to be measured. Any other movement, such as that resulting from vibration, is prevented by the mechanical contact of the plates and spheres.

The standardisation of the metre in terms of the wavelength of light has been carried out by counting the number of fringes appearing when the mirrors are separated by an amount equal to the length of a gauge. The gauge is then compared with the substandards which are compared with the standard metre itself. This type of measurement, as indeed most measurements involving the parallel plate system, is very difficult to carry out, and forms a rather specialised branch

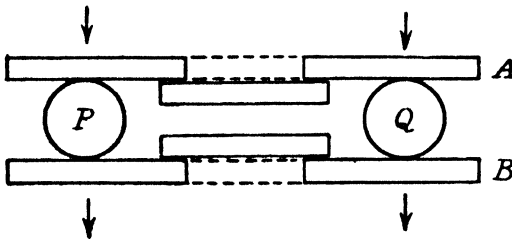

FIG. 22.—Parallel Plate Interferometer (Phillips and Pollard).

of physical measurement. Anything more than the bare outline given above is therefore beyond the scope of this book, but further reference may be made to *Applications of Interferometry*, W. E. Williams, London, 1930.

Inclined Plate System

This difficulty does not apply to the inclined plate system, which will therefore be considered in more detail. If the plates are slightly inclined to each other, their separation varies from point to point and the phase relation of the two rays received from them also varies from one point to another. The telescope, which does not differentiate between the rays coming from different parts of the plates, is therefore replaced by a microscope, by means of which the rays coming from one point are focused at a single point on the image. Thus in the inclined plate system the rays coming from a single point are focused at a point, while in the parallel plate system, all rays parallel to a given direction are focused at a point.

The details of the microscope, *i.e.*, magnification, aperture, etc., must depend on the particular application contemplated. As a typical case, consider two plates A and B (Fig. 23) slightly inclined to each other, and prepared so that the reflections from the lower face of A and the upper face of B predominate. The microscope

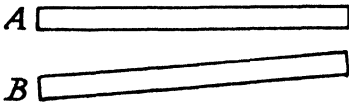

FIG. 23.—Inclined Plate System.

must be focused at the point where the two parts of the original ray intersect after reflection and it will be seen from Fig. 24 that this point of focus depends upon the angle that the incident ray makes with the first surface; the ray marked I represents the incident ray, R_1 and R_2 the rays reflected from the first and second surfaces respectively, and F the point of intersection of these rays either actually or when produced backwards. It will be

depends upon the angle that the incident ray makes with the first surface; the ray marked I represents the incident ray, R_1 and R_2 the rays reflected from the first and second surfaces respectively, and F the point of intersection of these rays either actually or when produced backwards. It will be

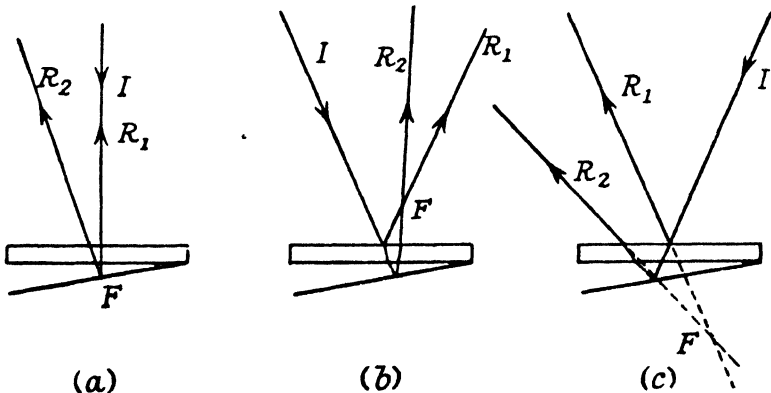

FIG. 24.—Intersection of the Reflected Rays.

apparent that the intensity resulting from the simultaneous observation of these two rays will depend on the phase relation between them. This phase relation depends on the path difference exactly as in the case of the parallel plate system. Consideration of the diagram (Fig. 17) will show that the phase difference will depend upon the angle of incidence and on the separation of the plates. Consequently, for rays with a given angle of incidence, there is a definite point on which the microscope should be focused, and when this is done, the

field will be crossed by alternate light and dark bands if monochromatic light is used. If rays with angles of incidence of differing values are received, the fringes will become blurred owing to the fact that the positions of the bands depend on the angle of incidence. The use of a parallel beam of light is therefore advisable, and will be considered later from the practical point of view. It may also be observed here that both the change in path difference and the movement of the point F when the angle of incidence is varied are greater if the separation of the plates is increased. Both of these changes depend on the distance between the point of incidence of the light and the line of intersection of the two reflecting surfaces.

The fringes corresponding to one angle of incidence will be alternations of light and dark, each fringe representing a "contour" or "line of iso-separation" of the two surfaces. For light incident normally and viewed by reflection (Fig. 24, diagram (a)) the dark fringes appear when the separation of

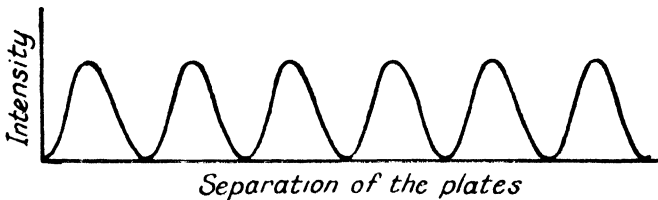

FIG. 25.—Relation between the Intensity of the Light and Separation of the Plates.

the plates is 0 , $\lambda/2$, λ , etc., because the path difference is twice the separation of the plates, and the reflections reverse the phase of one component.

Before considering the applications of this type of fringe system, let us examine a second factor that controls the characteristics of the fringes. Under the conditions contemplated so far, interference is regarded as taking place between two rays only, the two rays having equal intensities. The resulting intensity, plotted against separation of the plates, would be as shown in Fig. 25. This state of affairs is never realised because further reflections always take place, the resulting intensity being due to a series of reflected rays. For clarity,

this will be represented in connection with the parallel plate system, Fig. 26, although it applies equally to the inclined system. The resultant ray Z will be made up of components resulting from the incident rays a, b, c, d , etc. Since the light is only partially reflected at each reflection, the rays resulting from a and b will be the most intense, and so the conditions derived above for the production of maxima and minima of intensity will still apply. Thus a maximum will be seen when the parts of a and b which reach the eye are in phase, and a minimum when they are out of phase.

The effect of the rays c, d , etc., will be to alter the brightness,

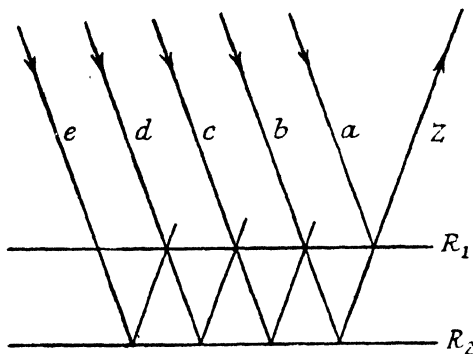

FIG. 26.—Series of Rays (a, b, c , etc.) which combine to form the Resultant Ray Z .

contrast and sharpness of the fringes. Since the intensities of these components, as well as the intensities of the primary interfering components a and b , depend on the reflecting powers of the two surfaces, it is useful to discuss the effects of various reflecting surfaces on the characteristics of the fringes that result.

It will be assumed that conditions have been arranged so that the only light that is received is that which is reflected from the lower surface of the upper plate and the upper surface of the lower plate. This can easily be arranged by using optical flats of which the two faces are not quite parallel. The intensity at any point is given by the square of the resultant amplitudes of all the components that are effective at that point. If the amplitudes are respectively a, b, c, d ,

etc., and if b, c, d , etc., are out of phase with a by $\theta_b, \theta_c, \theta_d$, etc., it can easily be shown that the resultant amplitude is

$$a + b \cos \theta_b + c \cos \theta_c + d \cos \theta_d, \text{ etc.}$$

If $\theta_b = 0^\circ$ (i.e., if a and b are in phase) the resultant amplitude is a maximum and its value is

$$a + b - c + d - e, \text{ etc.}$$

while if $\theta_b = 180^\circ$, the amplitude, a minimum, is

$$a - b - c - d - e, \text{ etc.}$$

This allows us to find the maximum and minimum amplitudes of a series of fringes if a, b, c , etc., are known; hence the brightness and the contrast can be determined.

The sharpness of the dark fringes is determined by the intensity of light at a point a short distance from the point of maximum darkness. If this intensity is large, the fringe is sharp, if small, the fringe is broad. Consider a point at which the path difference is such that $\theta_b = 170^\circ$, instead of 180° as it would be at the point of minimum intensity. At this point, c will be 10° out of phase with b , d 10° from c , and so on. Hence the various rays bear the following phase relations to a ; $\theta_b = 170^\circ$, $\theta_c = 160^\circ$, $\theta_d = 150^\circ$, $\theta_e = 140^\circ$, and so on. The amplitude at this point is equal to $a + b \cos 170^\circ + c \cos 160^\circ + d \cos 150^\circ$, etc., and since the cosine of an angle varies from -1 at 180° to 0 at 90° , it follows that the intensity is greater at the point considered if c, d , etc., are large than if they are small, because the components due to c, d , etc., which are subtracted from a , are smaller. Thus it is seen that sharp fringes are formed if c, d , etc., are large compared with a , while if they are small, the fringes are broad.

Thus the sharpness of the fringes depends on the ratios $\frac{c}{b}, \frac{d}{c}$,

which are found to be equal. The fringes are sharp when $\frac{c}{b}$

is small. The relation between intensity and path difference for fairly sharp fringes is shown in Fig. 27. It follows that the characteristics of the fringes depend on the relative amplitudes of a, b, c, d , etc., and the expressions relating these with the reflecting powers will be derived for fringes viewed by reflection.

Let the reflecting powers of the two surfaces (Fig. 25) be R_1 and R_2 , and let the intensities of the components be A , B , C , D , etc., the amplitudes being a , b , c , d , etc.

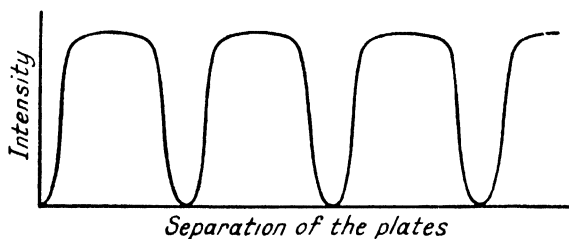

FIG. 27.—Relation between Intensity and Separation of the Plates for sharp Fringes.

$$\begin{aligned} \text{Then } A &= R_1 \\ B &= (1 - R_1)^2 R_2 \\ C &= (1 - R_1)^2 R_1 R_2^2 \\ D &= (1 - R_1)^2 R_1^2 R_2^3 \\ &\text{etc.} \end{aligned}$$

Then the intensity of the maximum, $I_{\max.}$, is

$$\begin{aligned} I_{\max.} &= (a + b + c + d \dots)^2 \\ &= \{ \sqrt{R_1} + (1 - R_1)\sqrt{R_2} + (1 - R_1)\sqrt{R_1 R_2^2} + \dots \}^2 \end{aligned}$$

while the intensity of the minimum, $I_{\min.}$, is

$$\begin{aligned} I_{\min.} &= (a - b - c - d \dots)^2 \\ &+ \{ \sqrt{R_1} - (1 - R_1)\sqrt{R_2} - (1 - R_1)\sqrt{R_1 R_2^2} - \dots \}^2 \end{aligned}$$

The important results are—

- (1) $I_{\max.}$, the brightness of the fringes,
- (2) $\frac{I_{\min.}}{I_{\max.}}$, the contrast of the fringes,
- (3) The ratio $\frac{c}{b}$ which expresses the sharpness of the fringes.

The following examples are instructive in this connection :
 (1) $R_1 = 0.04$, $R_2 = 0.04$ (this is the approximate value for glass).

$$I_{\max.} = 0.152, \quad I_{\min.} = 0.000041.$$

$$\text{Ratio of } I_{\min.} \text{ to } I_{\max.} = 0.00027.$$

$$\text{Ratio of successive components} = 0.0004.$$

(2) $R_1 = 0.5$, $R_2 = 0.5$ (this is obtained by using semi-silvered surfaces).

$$I_{\max.} = 0.6855, I_{\min.} = 0.4473.$$

$$\text{Ratio of } I_{\min.} \text{ to } I_{\max.} = 0.651.$$

$$\text{Ratio of successive components} = 0.5.$$

It follows that the use of semi-silvered surfaces should give very much narrower fringes but that the contrast between the brightest and darkest parts is not very great. This confirms the conclusion arrived at experimentally that it is of no advantage to use semi-silvered mirrors for viewing reflection fringes. It should be noted that the conditions for the production of sharp fringes by transmission are different from those

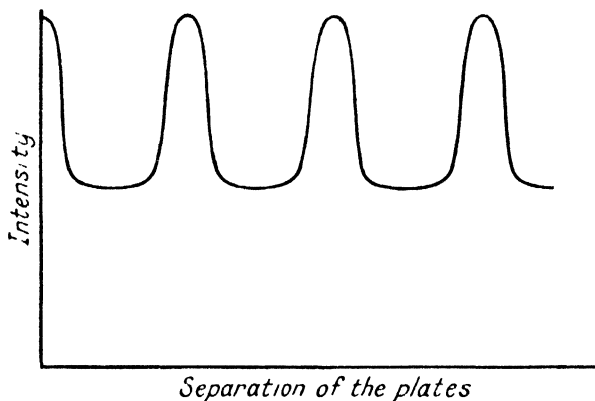

FIG. 28.—The Intensity-separation Relation for Fringes seen by Transmission. Conditions as for Fig. 26.

discussed above, and the use of semi-silvered reflectors is an advantage in this case. The transmitted beam is complementary to the reflected one, and under the conditions relating to Fig. 27 it would be represented as in Fig. 28.

It has been assumed that all possible components of the series of reflected rays should be included in the calculations of the intensities; in the inclined plate system, however, this is not necessarily true, and if the separation of the plates is large, the number of components to be considered is reduced owing to the lateral displacement of the multiply reflected rays and to the fact that all the rays do not intersect at the

same point and cannot therefore be focused simultaneously by the microscope (see Fig. 29). It is also apparent that the path differences change with the lateral movement of the point of reflection due to successive reflections. These difficulties can only be partially overcome, and a large separation (over 5 mm. for sodium light) results in the fringes viewed by reflection becoming very diffuse and lacking in contrast. If the eye is used to detect the fringes, then the considerable depth of focus that characterises the eye, on account of its

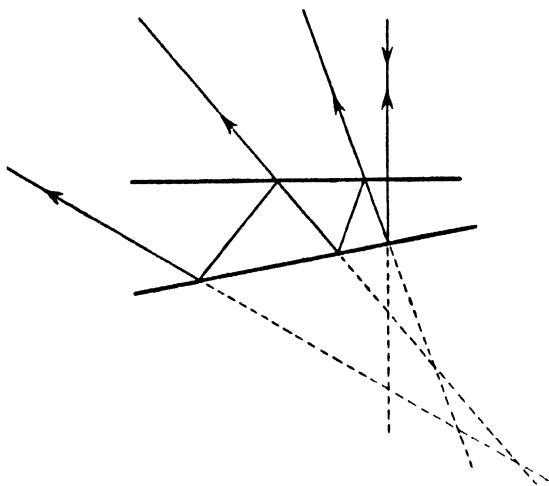

FIG. 29.—Intersection of the Reflected Rays ;
inclined plate.

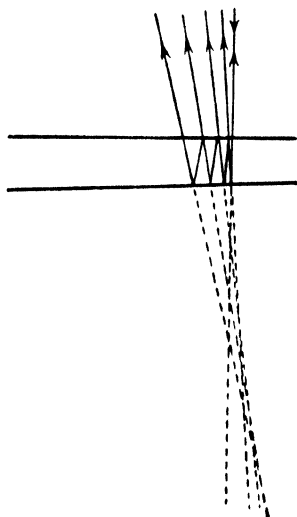

FIG. 30.—Intersection
of the Rays ; nearly
parallel plates.

short focus and its small aperture in the presence of bright light, enables fringes to be seen under conditions in which they are not easily detected in the microscope. The depth of focus required is increased if the plates are very nearly parallel, since the successively reflected rays are also more nearly parallel (see Fig. 30).

To summarise the conditions for the production of sharp fringes :—

- (a) Incident rays must be nearly parallel.
- (b) The reflecting powers must be fairly small and about equal for fringes viewed by reflection.

- (c) The separation of the plates must be small and the plates must not be too nearly parallel if the fringes are to be viewed with a microscope.
- (d) The light must be strictly monochromatic.

As will be seen when the applications are reviewed, cases arise in which the reflecting power of the lower reflecting surface is not under control. It generally has a high value in these circumstances and it is of interest to examine the effect of the reflecting power of the upper reflecting surface on the resulting interference phenomena. The cases that are of interest are those in which the lower surface is that of a metal and the fringes are formed either between the metal surface and the upper side of an oxide or tarnish film, or between the metal surface and a glass flat that is held in contact with it. In either case it is justifiable to assume that the reflecting power of the lower surface is very large, probably over 80 per cent. The following cases illustrate the points to be considered :—

(1) $R_2 = 1$, $R_1 = 0.5$. Calculation on the lines indicated above shows that the intensity is 1 for any phase relation between the component beams. This is to be expected from the principle that no light is destroyed in the interference process. In the cases hitherto considered, the light that is missing from the reflected beam is found in the transmitted beam. In this case, however, there is no transmitted beam and no light is absorbed and so all the incident light must be included in the reflected beam.

(2) $R_2 = 0.8$, $R_1 = 0.5$. Then $I_{\max.} = 0.98$, and $I_{\min.} = 0.49$, the ratio of intensities being 0.5 to 1. The ratio of successive terms is 0.40 and this represents quite good, well defined fringes.

(3) $R_2 = 0.8$, $R_1 = 0.04$. $I_{\max.} = 0.928$, $I_{\min.} = 0.845$, ratio = 0.91, ratio of components = 0.18.

This shows that where the lower reflecting surface is a good reflector, the upper reflector should also be a good reflector, the optimum value being $R_1 = 0.5$.

It will be found in what follows that the conditions considered above are adhered to in the most successful applications.

The theory given above requires modification if the film is

composed of an absorbing or scattering medium, because this will affect the amplitudes of the reflected components.

Let R_1 and R_2 be the two reflecting powers as before ; let the intensity of the light be reduced in the ratio $S : 1$ when the light passes once through the film (*i.e.* from the front to the back, or from the back to the front).

The intensities of the components (see Fig. 26) are—

$$A = R_1$$

$$B = (1 - R_1)^2 \times S^2 \times R_2$$

$$C = (1 - R_1)^2 \times S^4 \times R_2^2 \times R_1$$

$$D = (1 - R_1)^2 \times S^6 \times R_2^3 \times R_1^2, \text{ etc.}$$

The chief interest of this case is in connection with the colour films (*vide infra*) and examples of particular importance are those in which R_1 is small, R_2 is equal to one, and the absorption is moderately large.

$$(a) \text{ Let } R_1 = 0.1, R_2 = 1.0, S = 0.2$$

$$\text{then } I_{\max.} = 0.18$$

$$\text{and } I_{\min.} = 0.13$$

$$\frac{I_{\min.}}{I_{\max.}} = 0.72$$

and the ratio of successive terms is 0.004.

$$(b) \text{ Let } R_1 = 0.1, R_2 = 1.0, S = 0.8$$

$$\text{then } I_{\max.} = 0.94$$

$$I_{\min.} = 0.80$$

$$\frac{I_{\min.}}{I_{\max.}} = 0.85$$

and the ratio of terms is 0.4.

These results show that the fringes are broad with fair contrast in the case *a*, and sharper and with less contrast in the case *b*. The results are of importance as they show that fringes can be formed when $R_2 = 1$ providing that the material of which the film is composed scatters or absorbs some of the light.

Michelson Interferometer

The operation of any interferometer depends on the division of a beam of light into two parts that are subsequently recombined after following different paths. In the type of interfero-

meter that has already been discussed, the beam of light is partially reflected and partially transmitted by two parallel or nearly parallel plates, the path difference depending on the distance between the plates. An alternative method of dividing the beam is that of the Michelson interferometer, the optical arrangement of which is illustrated in Fig. 31. A parallel beam of light AB is partially reflected and partially transmitted by the semi-silvered glass plate B . The two resulting beams of light BC and BD are reflected by the mirrors R and S , and on reaching B they are recombined as the beam BE which is observed by means of a telescope

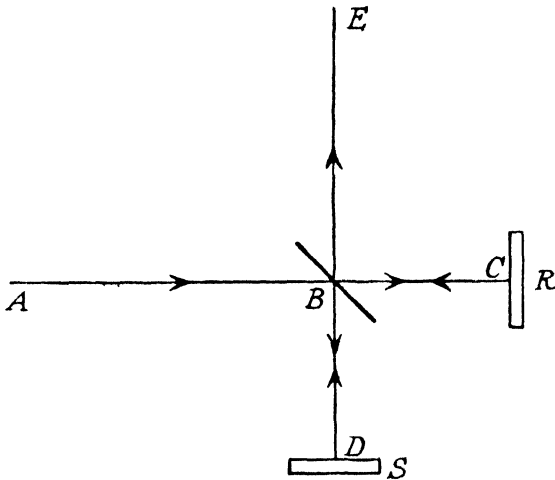

FIG. 31.—Michelson Interferometer.

focused for parallel light. If the mirrors R and S are exactly perpendicular to the rays BC and BD respectively, then the system is equivalent to the parallel plate system discussed in the preceding sections. A system of circular fringes is seen in the telescope, and when either R or S is moved parallel to itself the fringes move either inwards or outwards according to whether the difference between BC and BD is increased or decreased. If this difference changes by half a wavelength, the fringes move so that each fringe occupies the position previously occupied by its neighbour.

If the mirrors R and S are not both exactly perpendicular to the light beams BC and BD the arrangement becomes an

inclined plate system, and, as explained above, the fringes can only be seen by means of a microscope focused on a definite plane near the reflecting surfaces. An instrument which embodies this principle is described in the next section.

The characteristics of the fringes depend upon the same factors as in the cases discussed previously. It is clear from the optical system concerned that interference takes place between two beams of light only, as no multiple reflections can take place. The fringes will therefore always be of the form shown in Fig. 24, the only variable factor being the contrast between maximum and minimum intensities. This depends on the ratio of the reflecting powers, and it can be made very large by adjusting conditions so that the two interfering beams are of equal intensity. Thus the fringes will be characterised by high contrast and some lack of sharpness. It is also evident that the fringes produced by this system can be focused more definitely than when multiple reflections are involved. A further consideration that is theoretically in favour of this type of interferometer as opposed to the simpler arrangement described above is that a perfectly reflecting mirror is permissible in this case but not in the other. Practical considerations show, however, that this is not an important feature.

Applications

The applications of the type of interference fringes of which the theory has been discussed in the preceding section can be grouped under four headings :

- (a) for measuring the relative movement of two components of an instrument,
- (b) for studying the topography of a surface,
- (c) for studying the thickness of a transparent or semi-transparent film,
- (d) other applications.

These four types of application will be considered separately, the general principles involved being detailed first, followed by descriptions of some of the more important examples.

Measurement of Relative Movement

For convenience we have so far confined our treatment of interference fringes to the fringes between flat surfaces ; if,

however, the conditions are such that the fringes appear to be formed close to the reflecting surfaces, then each point of the surfaces can be regarded as possessing a characteristic brightness which depends on the separation of the surfaces at this point. The fringes result from the alternations of this brightness caused by the variation of the distance between the plates. With flat surfaces the fringes will be straight and parallel to the line of intersection of the two reflecting planes. There is no necessity for the surfaces to be plane, and a convenient way of producing the fringes is to place a convex lens nearly or quite in contact with a flat glass plate. The fringes are then circular, surrounding the point of nearest approach. The radii of the rings are roughly proportional to the square roots of the integers for the following reason. A dark fringe occurs where the distance d between the plate is $0, \frac{\lambda}{2}, \lambda, \frac{3\lambda}{2}, \text{etc.}$,

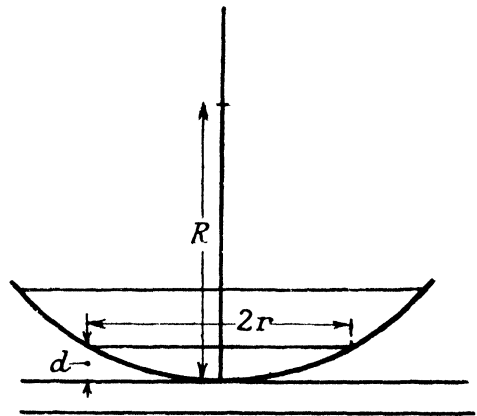

FIG. 32.—Radii of Newton's Rings.

because, as was shown above, the primary interfering rays are out of phase when the separation has these values. If r is the radius of the ring at which the separation is d , (Fig. 32) and if R is the radius of curvature of the lens, it follows from the geometry of the circle that $2R \times d = r^2$ approximately, or, more precisely, $(2R - d)d = r^2$. Since d has values $0, 1, 2, 3, \text{etc.}$, times $\frac{\lambda}{2}$ for the dark fringes, and since $r = \sqrt{2R \times d}$ approximately, it follows that values of r for the dark fringes are proportional to $0, 1, \sqrt{2}, \sqrt{3}, \text{etc.}$

This system of fringes, discovered by Newton, and generally known as Newton's rings, has been used by several investigators as a method of measurement. Let us examine the behaviour

of the fringes when the distance between the lens and the plate is altered. If the lens is moved away from the plate, the fringe $d = n\frac{\lambda}{2}$ will contract in size until the shortest distance

between the two surfaces is $n\frac{\lambda}{2}$. This fringe will then only

exist at one point, and will therefore have devolved into a spot. An increase in the separation of the surfaces therefore causes a contraction of the circular fringes, each fringe ultimately disappearing at the centre of the system. If the distance between the lens and the plate is decreased, fringes appear as dark spots which then spread to become dark rings. When contact is made the dark spot corresponding to $d = 0$ occupies the centre of the system.

A movement of $\frac{\lambda}{2}$ in a direction at right angles to the plate causes the fringes to move so that each occupies the position previously occupied by the adjacent one. The actual amount of movement corresponding depends on the wavelength of the light used, and for the two most useful wavelengths the figures are—

$$\text{Mercury green} = 5460 \text{ A.U.}, \frac{\lambda}{2} = 2730 \text{ A.U. or } 0.0000273$$

cm.

$$\text{Sodium yellow} = 5893 \text{ A.U.}, \frac{\lambda}{2} = 2946 \text{ A.U. or } 0.0000295$$

cm.

An absolute movement of about 3×10^{-5} cm. therefore causes the fringe system to move by one fringe space, without the use of any form of mechanical magnification.

This system has been applied by Searle¹ for measuring the Young's modulus of bars of metal. The specimen A (Fig. 33) is firmly fixed into the base B and two cross-bars P and Q are attached rigidly at the positions shown. A lens L and a plate P are attached to P and Q respectively. A load is applied at C on a crossbar fixed to the top of A. This causes A to

¹ Searle, *Experimental Physics*, Cambridge, 1934, p. 113; *Proc. Camb. phil. Soc.*, **22**, 475.

bend, which alters the angle between P and Q, thus increasing the separation of L and M. The interference fringes between L and M are observed by means of the microscope N, monochromatic light from the source S being used to illuminate M and L by means of the plate T. This apparatus, for full

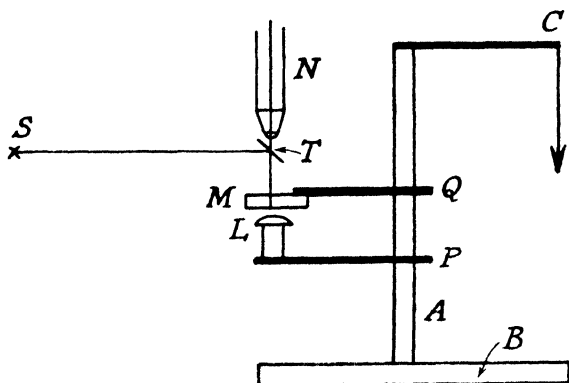

FIG. 33.—Diagram of Searle's Method of measuring Young's Modulus.

details of which the original publication must be consulted, was intended rather to illustrate the physical principles concerned than as a useful method of measuring Young's modulus, and it is therefore not proposed to discuss the details of design or manipulation any further here.

An application of greater technical use of the same method was described by Davies.¹

The apparatus was designed to measure both the Young's modulus and the rigidity modulus of test pieces of cylindrical form. The method, for details of which the original paper should be consulted, was to clamp

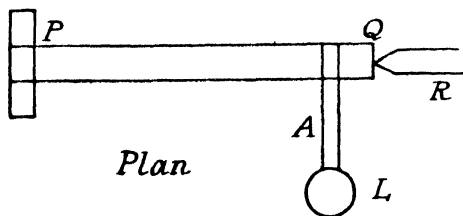

FIG. 34.—Diagram of Davies' Apparatus for measuring the Elastic Moduli.

the test piece PQ (Fig. 34) rigidly at the end P, and to provide a centre point R that could be used to prevent any movement, other than rotary, of the end Q. The lens L of the

¹ Davies, *Engineering*, 1938, 145, 580.

Newton's ring system was attached at the end of an arm A clamped to the rod near Q, the flat glass plate being attached to the rigid base. Two methods of loading could be used, either bending the rod by a vertical pull at right angles to its length applied near Q, or else twisting it by means of a tension applied at right angles to an arm similar to A, the support R being used in this case to prevent bending. The strains resulting from these two kinds of stress were measured and stress strain curves for bending and torsion were obtained. The elastic moduli can be calculated from these data and the dimensions of the test piece by the usual methods. Corrections were applied for "give" at the clamp P and for bending during the torsion experiment.

In this type of experiment the method of taking readings is usually to apply the load slowly and evenly, stopping whenever a fringe (or every other fringe, or any suitable number) passes a given point on the field of the microscope through which the fringes are observed. The reading is probably correct to one tenth of a fringe, and so the stress required to cause a movement of 3×10^{-6} cm. can be measured fairly easily. The chief difficulty in devising apparatus of this sort is to eliminate the effect of vibration, which can easily render the fringes unsteady or even invisible.

A further difficulty which arises if a higher degree of accuracy than about one tenth of a fringe is required is the fact that the fringes of a Newton's ring system are not evenly spaced, their radii being in the ratio of the square roots of the integers. It is possible to estimate fairly accurately when a fringe is on the cross wire of the observing microscope, but it is impossible to estimate with any accuracy what fraction of a fringe is equivalent to any other position of the fringes with relation to the cross wire.

For these reasons the inclined plate system with flat plates has been utilised for two high-precision instruments that have been described recently. These instruments, due to Chalmers¹ and to Cuthbertson² respectively, were designed for use on soft metals in which the total elastic strain is small.

¹ Chalmers, *J. Inst. Met.*, 1937, **61**, 294.

² Cuthbertson, *J. sci. Instrum.*, 1937, **14**, 268.

The upper end of B is pivoted on the cross-bar C, which in turn is pivoted on two parallel bars D, of which only one is represented in the diagram. Each of these pivots consists of two gramophone needles held vertically and resting in punch holes, the result being that no couple is applied to B. The bars D are fixed together by means of cross-bars, and pivot on the points of two gramophone needles E, carried by screws passing through the cross-bar F of the main frame. A cross-bar at G, connecting the two bars D, supports a glass tube H, 25 cm. long, and 6 cm. in diameter, closed at its lower end and open at the top. Water can be introduced into, or removed from, the tube H, by means of a two-way syphon (not shown in the diagram). The stress applied depends on the water level in the tube H, the stress being zero when the weight of water in H is just sufficient to balance the counterpoise weight at J. The water level in the tube H, is determined by means of a pointer which is moved vertically so as just to touch the water surface. The pointer is supported by a glass rod that moves along a scale. The tube H is calibrated by introducing known amounts of water and observing the change in water level.

The strain is measured by determining the changes in the distance between two points on the specimen. This measurement is made by an optical interference method as follows. Two screws K, 4 cm. apart as measured along the bars Z, Z, each carry a gramophone needle, point upward. On these points rests a brass frame L, the bearing surface being of hard steel. A flat piece of glass M is rigidly attached to L. The device by which the motion of the specimen is communicated to the frame L is shown in Fig. 35b, and consists of two similar brass plates, between which are held two razor-blades of the three-hole type. The positions of the razor-blades, which lie in a horizontal plane, are shown by dotted lines in Fig. 35b. The razor-blades are set just to cut the surface of the specimen when it is inserted.

The second frame P of the interferometer holds a second glass plate Q and a second device R similar to that shown in Fig. 35b. The frame P is supported on L at two points by means of two screws T, the actual points of support again

being gramophone needles projecting downwards from the screws and resting on a piece of steel. The distance and angle between the glass plates Q and M can be adjusted by means of the screws T.

The frames L and P are each counterbalanced by adjustable weights at U and V so that no stress is applied to S through R or N. The interferometer is illuminated from above by means of light from a mercury lamp passing through a water cell and a mono-chromatic green filter, and reflected downwards from the glass slip X. The fringes produced by the interference between the light reflected upwards from the lower surface of Q and from the upper surfaces of M are viewed through a microscope at W. The direction and spacing of the fringes, which are lines of equal separation of M and Q, can be adjusted by means of the screws T. This adjustment is made so that the fringes form a series of parallel lines whose direction is parallel to the axis about which the interferometer unit turns. When the distance RN alters, the fringes move in a direction perpendicular to their length. Good fringes are obtained with no silvering on Q or M, which were pieces of good plate glass.

The apparatus was supported in a thermostatic water-bath of which the temperature variations were less than 0.05° C. Vibration was obviated by placing the whole apparatus on a pier with a foundation independent of the rest of the building, a heavy slate top being supported on the pier by twelve rubber-sponge balls. No vibration that could be detected was transmitted through this arrangement, although the pier itself underwent considerable vibration.

The syphon apparatus, the device for measuring the water level, the stirring motor and the mercury arc were supported on a second bench to avoid any disturbance originating from them.

The length of the specimen between R and N was about 3 cm. and the change of this length which will cause a displacement of the fringe system by one fringe space is 3.68×10^{-5} cm., so that $\Delta l/l$, the extension per unit length per fringe, is 1.23×10^{-5} approximately. The microscope used for observing the fringes contained an eyepiece scale. By

adjusting the fringes to be about ten scale divisions apart, and reading the positions of the fringes to one-tenth of a scale division, movements of the fringes could be determined to 0.01 fringe. This represents a value of $\Delta l/l$ of 1.23×10^{-7} . The accuracy of reading the water level was comparable, a change of water level of 0.1 mm. corresponding roughly to a change of length of 10^{-7} .

Cuthbertson's instrument depends on the measurement of the vertical movement of the centre of the specimen AB (Fig. 36) when equal forces W are applied to the two ends. The specimen is supported on knife edges P and Q. The load $2W$ is applied at the centre of the cross bar MN. In

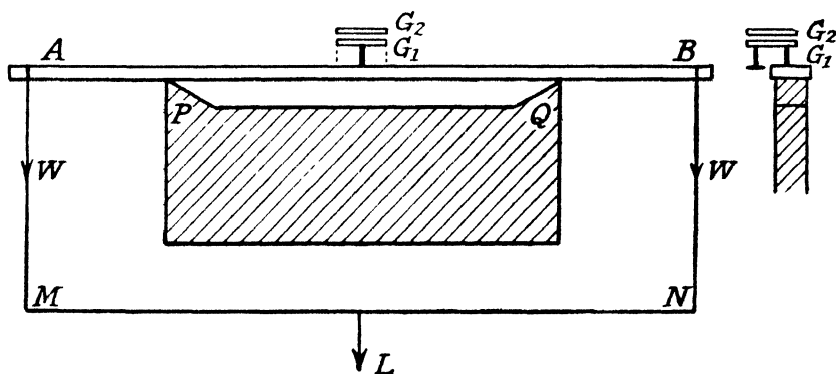

FIG. 36.—Plane Bending Apparatus (Cuthbertson).

this way equal loads of W are applied to the two ends of the specimen. Interference fringes are formed between a glass plate G_1 supported on three points of which one is at the centre of the specimen, and a glass plate G_2 which is fixed relatively to the knife edges P and Q. For work at elevated temperatures, a long connecting rod stands on the specimen at its centre and supports the point on which the mirror table rests. This is necessary as the interferometer must be maintained at a constant and reasonably low temperature. The fringes are observed by the usual method, monochromatic light from a mercury lamp being reflected down on to the interferometer by a glass reflector, and a microscope with a micrometer eyepiece is focused on the fringes. If the microscope is focused on the plates directly

above the point where G_1 is supported on the specimen, then the relative movement of the plates is equal to the vertical movement of the specimen. The migration of one complete fringe (so that one fringe moves to the position previously occupied by its neighbour) represents a movement of one half wavelength or 2.73×10^{-5} cm. if a mercury vapour source of light is used. The eyepiece scale permits measurements to a hundredth of a fringe, and therefore movements of 2.73×10^{-7} cm. or about 10^{-7} inches, can be measured. If this method of measurement is utilised, it is necessary to apply the load slowly and to observe the motion of the fringes continuously, and for the greatest sensitivity this is essential. When a lower degree of accuracy is permissible, as was the case in much of Cuthbertson's work, it is possible to take observations by a much less laborious method, in which continuous observation of the fringes is not necessary. The method is to measure the width of 50 or 100 fringes over a fixed region of the mirrors and to calculate from this the average distance between two fringes. The change of fringe spacing that accompanies an increase or decrease of load is a measure of the vertical movement of the centre of the specimen. If a measuring microscope is used for observing the fringe spacing, a degree of accuracy that is sufficient for many purposes is obtained. The possibility of taking periodic observations over a long time, which this method allows, may more than compensate for the reduction in sensitivity involved.

The modulus of elasticity E can be calculated from the data obtained (L_2 and L_1 are the values of the final and original loads, D is the distance between knife edge and point of application of the stress, L the distance between knife edges, Δ_2 and Δ_1 the final and initial displacements of the centre of the specimen, and I the moment of inertia of the cross section of the specimen) by means of the formula

$$E = \frac{(W_2 - W_1) DL^2}{16(\Delta_2 - \Delta_1) I}$$

It should be observed in connection with measurements of the accuracy attained in the two methods described above

that the control of temperature is very important. This applies particularly in the case of the extensometer, where any change due to thermal expansion would be recorded as actual extension or contraction of the specimen. The smallest extension that can be observed (1.2×10^{-7} cm./cm.) is about equal to the thermal expansion that would result from a rise of temperature of 0.01° C. Hence a thermostat working between narrow limits is required if the high sensitivity is to be utilised fully.

The choice of one or other of these methods depends upon the purpose for which the measurements are to be made. If the absolute elastic properties and the transition from elastic to plastic conditions are being examined, then the tensile test must be adopted. In this case the whole of the test piece is under the same stress when a given load is applied, and the elastic limit, yield point, etc., are reached by the whole specimen at once. This leads to a much more definite determination of such points than the bending methods, in which the most highly stressed parts (upper and lower surfaces) reach the critical stresses first, while the remainder is still behaving in a manner characteristic of lower stresses. The latter method is quite suitable for measuring the modulus of elasticity and for rough comparisons of the limits of elasticity of different materials. It is rather easier to manipulate and does not require such rigid temperature control as the tensile method.

Dilatometers

The sensitivity with which small changes of size and shape can be measured by means of the inclined plate interferometer has led to its adoption in various methods of measuring the variation of linear dimensions of solids with temperature. The first use of interference fringes for the measurement of thermal expansion is due to Fizeau, and is chiefly interesting as an early application of interference fringes for measurements. An adaptation of Fizeau's method for measuring the thermal expansion of metals is illustrated in Fig. 37(a). The specimen S rests on the base B, on which is also supported the glass flat P_1 . If the upper surface of the specimen is sufficiently plane, the second mirror, P_2 , can be dispensed

with, the fringes being formed between the plate P_1 and the surface of the specimen. Any difference between the expansions of the specimen S and the components R which support the plate P_1 is revealed by a movement of the interference fringes. Such an instrument cannot be regarded as absolute, since the results depend on a knowledge of the expansion of the components R .

A second method is illustrated in Fig. 37b. In this case the specimen S is in the form of a ring, P_1 and P_2 being placed as shown. Fringes are formed between P_1 and P_2 , and their movement represents the actual expansion of the specimen, a small correction being necessary for the expansion of the

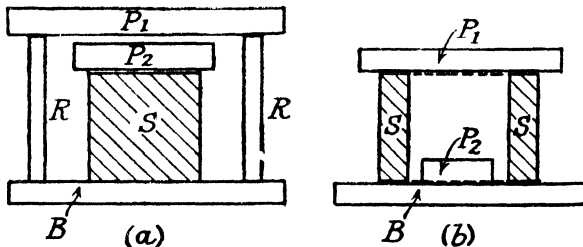

FIG. 37.—Interference Dilatometers.

glass plate P_2 . This method, which gives absolute results, has the disadvantage that the length of the specimen is controlled by the maximum separation of P_1 and P_2 at which the fringes can be observed satisfactorily. If the length of the specimen is increased and the plate P_2 is supported closer to P_1 , the readings are no longer absolute, but represent the differential expansion of S and the material on which P_2 is supported. It will be appreciated that these methods are very well adapted for the measurement of thermal expansions of small specimens, but that a high degree of accuracy is not to be expected.

A modification of the instrument illustrated in Fig. 36b, designed by Luckiesch, Holladay and Sinden¹ and used by Austin,² adapts the interference method for measuring the thermal expansion of materials that may only be heated

¹ Luckiesch, Holladay and Sinden, *J. Franklin Inst.*, 1922, **194**, 251.

² Austin, *Physics*, 1932, **3**, 240.

in vacuo. Two fused silica plates are held almost parallel and at a distance apart of the order of half a centimetre by means of three short specimens of very nearly equal lengths. The fringes formed between the two silica surfaces are viewed, and the relative movements of the two plates are determined by movements of the fringes. The instrument is set up in a furnace which can be evacuated, and by this method several difficulties are avoided. In the first place the dimensions of some materials change considerably when heated in air owing to oxidation, and secondly the change in the refractive index of air with temperature necessitates a correction if air is admitted between the interferometer plates. Since observations were taken up to 1000° C., it is clear that both the reasons given above are of importance. A disadvantage of the method is that the short length of the specimen restricts the accuracy of the measurements. A rather similar method has been described by Taylor, Willey, Smith and Edwards,¹ in connection with an investigation of the physical properties of some exceptionally pure aluminium. The test specimen was a ring of about 2 cm. diameter and about 5 mm. high, made by bending a strip into a circle. Small pins or legs were produced on each edge of the ring by filing away about half a millimetre of metal except where the pins were to be left. The legs were spaced at about 120° to each other. The ring was introduced between two quartz optical flats, and the legs were adjusted so that the slope between the plates gave the requisite number of interference fringes. The movement of the fringes, viewed in the usual way, revealed movements of 10^{-6} cm., and it was estimated that the coefficient of expansion was determined to a precision that was dictated not by the accuracy of this measurement but by such factors as the growth of the oxide film on the aluminium and unavoidable relative motion of the plates and the specimen.

The accuracy of such measurements can be considered as follows; assuming, as a standard, that the positions of the fringes can be estimated to one tenth of the fringe

¹ Taylor, Willey, Smith and Edwards, *Metals and Alloys*, 1938, 9, 190.

separation, the minimum amount of expansion that can be measured to an accuracy of one per cent. corresponds to ten fringes or

$$10 \times \frac{5.890 \times 10^{-5}}{2} \text{ cm.} = 3 \times 10^{-4} \text{ cm. approximately}$$

If we assume that the measurement is to be made on a material with a coefficient of expansion of about 1.5×10^{-4} cm./cm./° C. (*e.g.*, copper) then if the length of the specimen is 1 cm. the rise of temperature necessary to produce the required expansion is 2° C.: if it is half a centimetre in length, the rise of temperature required is 4° C. If the accuracy required is one part in a thousand the temperature rises will be 20° C. and 40° C. respectively. The purpose of precision measurements of thermal expansion is often connected with the investigation of changes of structure with temperature, and for such purposes a graph relating the coefficient of expansion with temperature is required. The change that is being sought often corresponds to a change of slope of the curve, and it is consequently necessary that each point on the graph should correspond to the mean expansion over the smallest temperature range possible. Hence the calculation given above reveals the true measure of accuracy, *i.e.*, the temperature range necessary so that each reading shall have a given accuracy.

An accuracy of 0.1 per cent. requires a range of about 40° C. in the apparatus described above, and consequently any change of slope of the curve may, if it is small, be completely hidden. This difficulty can only be overcome by reading to less than 0.1 fringe or by using longer specimens, or by combining some mechanical magnification with the optical system. Of these three methods the first will not lead very far because it is difficult to read to less than 0.1 fringe unless the plates are very nearly touching, and in the present case they are not. The third method can be ruled out owing to the difficulties introduced in connection with vibration if mechanical levers are introduced. That leaves only the second method, that of increasing the length of the specimen. Since half a centimetre can be regarded as the limiting path difference for fringes of this type, the

simple methods described above in which the path difference is equal to the length of the specimen cannot be adopted. Two alternatives present themselves : (a) the path difference can be reduced by the introduction of a component of some other material which is always at the same temperature as the specimen. This amounts to measuring the difference of the expansions of the two materials present. (b) The path difference can be reduced by means of a component that is kept at a constant temperature.

(a) For temperatures below 100° C., a component made of invar can replace most of the path difference, and its expansion can be regarded as known or negligible. For higher temperatures, quartz is often used, but this is not entirely unobjectionable as the expansion of quartz is suspected of possessing peculiarities that are not fully known. This method, not being absolute, is not ideal for the purpose, but providing its limitations are appreciated, it would be quite satisfactory.

(b) For absolute results, when the known expansion characteristics of quartz or invar are not regarded as sufficiently accurate, the second method commends itself. The difficulties encountered in designing a satisfactory instrument on this principle are considerable owing to the necessity of securing adequate temperature control, both of the specimen and of the constant temperature part of the apparatus, and because the problem of eliminating vibration increases as the mechanical contact between the specimen and the interferometer mirrors becomes less direct. An instrument of this type, however, in which the specimen has a length of 10 cm., would be a very valuable adjunct to the existing dilatometric equipment.

Interference Thermometer

A difficulty that is encountered in work of this kind is that of measuring the temperature to an accuracy comparable with that of the length measurement. This difficulty is more pronounced at higher temperatures, and although the subject is beyond the scope of the present book, there is one method that must be discussed here because it makes use of interference fringes. The interference thermometer

was first described by Luckiesch, Holladay and Sinden,¹ and was later used by Austin in the work referred to above.

The interference thermometer consists of a plate of fused silica with its two faces nearly but not quite parallel. Interference fringes are formed when monochromatic light falls on the plate, the positions of the fringes depending on the thickness and refractive index of the silica. Since both these characteristics are affected by the temperature, the positions of the fringes change with changing temperature. The thickness and angle of the plate determine the sensitivity, and a calibration against standard methods of temperature measurement is necessary. The instrument is particularly suitable for thermal expansion measurements as it can be used up to 1000° C., and it can be viewed through the same microscope as the fringes that indicate the expansion in an instrument such as that of Austin (*loc. cit.*).

Practical Considerations

The technique of precision measurements of this kind can only be acquired with practice, but one or two general observations can be made in this connection. In the first place, the adjustment of the inclined plates is always rather difficult, as it is necessary for this to be done extremely accurately. It is essential that the plates should be close together without touching, and that their relative slope should be such as to give a suitable spacing and direction to the fringes. A recommended procedure is first to set the plates as nearly parallel as possible by viewing a small aperture A (Fig. 38) placed in front of the source of light S by reflection in both plates P₁ and P₂. Since each plate has two surfaces, there will generally be four images of A. If these are brought into coincidence by adjusting the plates, then the plates will be very nearly parallel and the fringes can probably be seen by eye. Further adjustment of the plates may be necessary before the fringes are sufficiently well defined to be seen in the microscope. It is often useful to insert a thin piece of paper between the plates during the early stages of the adjustment in order to ensure that the plates themselves are not in contact. When readings are to be taken

¹ Luckiesch, Holladay and Sinden, *J. Franklin Inst.*, 1922, **194**, 251.

to an accuracy greater than that corresponding to one tenth of a fringe, it is essential to use a reading microscope provided with an eyepiece scale. If the fringes are adjusted so as

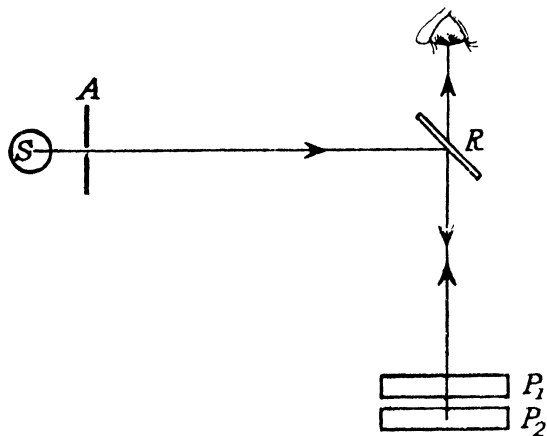

FIG. 38.—Adjustment of Interferometer Mirrors.

to be about ten eyepiece scale divisions apart, and the positions of the fringes are estimated to one tenth of a fringe, an accuracy of one hundredth of a fringe is attained. The

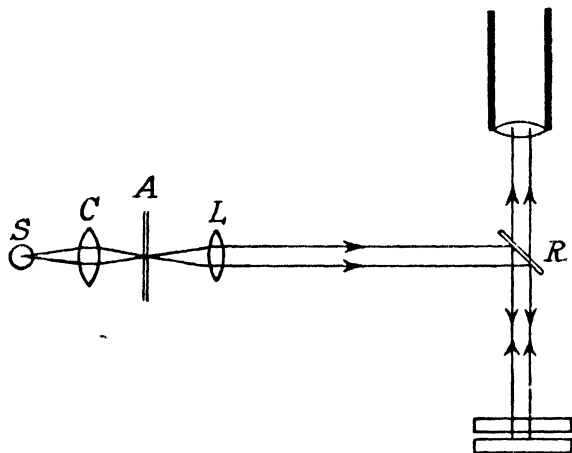

FIG. 39.—Optical System for Interferometer.

estimation of the position of the fringes to this accuracy requires considerable practice, but experience has shown it to be possible if the adjustments have been made correctly.

The second practical point to be considered is in connection with the light source. It has already been pointed out that the fringes are most clearly defined if the incident light arrives in one direction only. This can be arranged by using a point source of light in conjunction with a lens, the point source being at the principal focus of the lens. The most suitable arrangement is to use a fairly small aperture A (Fig. 39) strongly illuminated by the light from the source S focused by the condenser C. The lens L is placed so that its principal focus is at A, and the light is then converted into a parallel beam. In practice it is usually quite satisfactory to dispense with the lenses C and L and the aperture A provided that the reflector R is fairly small and the source of light is at least 20 cm. from it. This has the effect of limiting the angle of incidence to a sufficiently restricted range of values.

Micro-topography

The use of interference fringes as a method of testing the shape of surfaces is well known, but until recently it was confined to the examination of optical flats and lenses, the testing of the extremely flat surfaces required for the ends of gauge blocks and similar purposes. Since a particular fringe between two surfaces corresponds to a definite and constant separation of the surfaces, the fringe marks a line of "iso-separation" of the surfaces concerned. If one of the surfaces is known to be flat, then the fringes indicate the irregularities of the other surface.

For example, if two optical flats are held in contact with each other and viewed by monochromatic light, a series of straight fringes will be seen. If a piece of ordinary glass is substituted for one of the optical flats the fringes are no longer straight and equally spaced, but are much less regular, the extent of the irregularity depending on the unevenness of the glass.

The investigation of the configuration of a metallic surface by examination of the fringes formed between it and a flat glass plate was first described by Hoare and Chalmers¹ in connection with their study of tinplate. Their method was

¹ Hoare and Chalmers, *J. Iron and Steel Inst.*, 1935, **132**, 135.

to press a flat glass plate into contact with the metal to be examined between two plates. The upper plate *A* (Fig. 40) is provided with a hole through which observations are made. The optical flat *B* is pressed against the tinplate *C* by means

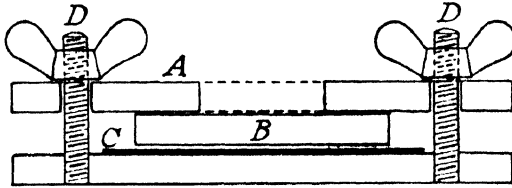

FIG. 40.—Interferometer for Micro-topography.

of the four screws *DD*. The optical flat and specimen are viewed from above, being illuminated by monochromatic light as illustrated in Fig. 41, the reflector *R* being either the vertical illuminator of the microscope or a separate external glass reflector. The fringes which are formed between

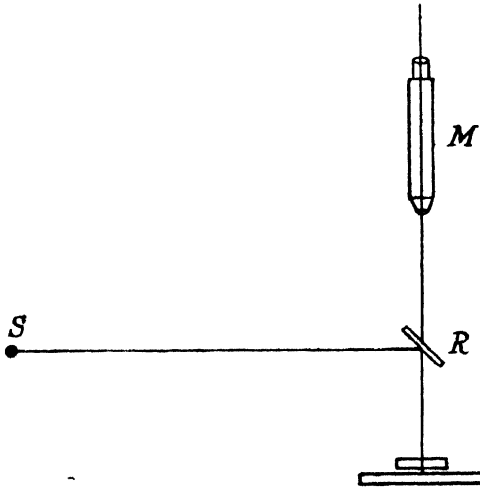

FIG. 41.—Optical System for Micro-topography.

the two surfaces are seen in the microscope *M*. When the surface under examination is fairly smooth, the fringes are widely spaced and can only be seen clearly under quite low magnifications, owing both to their wide spacing and to the depth of focus required to focus them. These fringes are usually of much less interest than those which reveal the

PLATE II.

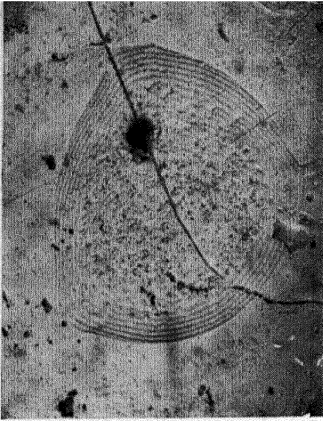

FIG. 42.—Grease Mark ($\times 80$).



FIG. 43.—Normal Pore ($\times 80$).

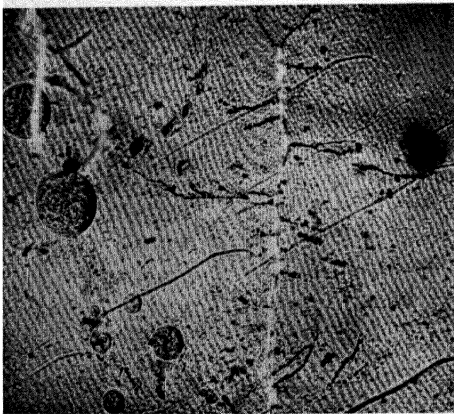

FIG. 44.—Tin Surface Crystal Boundary
($\times 80$).



FIG. 46.—Ridged Effect associated
with Grease Lines ($\times 25$).

presence and shape of severe irregularities of small size, such as the pores in tinplate, scratches in polished surfaces, the edges of components of different hardness in polished or abraded surfaces, or the effects of distortion such as slip or twinning. The original application of the method was to the examination of the irregularities occurring in the tin layer of tinplate. Since the actual shape of the irregularities was of interest, photographs were taken of the fringes, using a Busch box camera attached to the microscope. The magnification used was $\times 80$, and it was found advantageous to employ the vertical illuminator of the microscope instead of the external reflector R shown in Fig. 41.

Plate II (Figs. 42, 43 and 44) shows the fringe systems associated with grease marks, normal pores and crystal

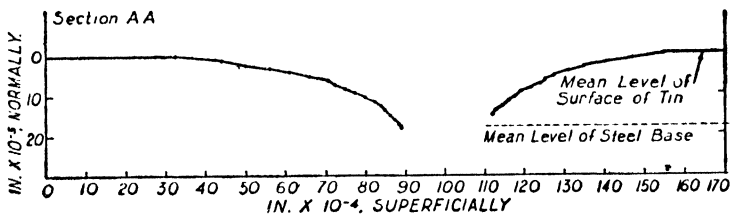

FIG. 45.—Examination of Normal Pore.

boundaries in the tin coating, and cross sections of the irregularities concerned are easily drawn on the basis that the depth corresponding to each successive fringe is one-half of the wavelength of the light used. The source of light used in these experiments was an "Osira" mercury vapour lamp with a Wratten filter No. 62, which excludes all light except the line of wavelength 5460 A.U., and so the successive contours correspond to differences of $\frac{5.46 \times 10^{-5}}{2}$ cm. or

0.0000273 cm. of depth. Fig. 45 shows the transverse section corresponding to the fringe systems shown in Fig. 43. Fig. 46 is a photograph taken at a rather lower power ($\times 25$) illustrating the ridged effect of the surface of tinplate associated with the grease lines that are often observed on the surface.

Further work by the same authors¹ has shown that greater

¹ Hoare and Chalmers, *Nature*, 1938, **141**, 475.

contrast and better photographs are obtained if the lower surface of the optical flat is semi-silvered or semi-platinised. This is in accordance with the theory given above that when the second surface of the interferometer is a good reflector (as with tinfoil) the first surface should reflect about 50 per cent. of the light falling on it. It was also found that the fringes were more easily seen and photographed if an "Osira" sodium lamp was substituted for the mercury lamp. This is because the sodium light is in the region of the spectrum to which the eye is most sensitive, and no filter is required because the light is practically limited to the nearly monochromatic light of wavelength 5.89×10^{-5} cm. This results in a definite but unimportant reduction in the sensitivity of the method, the depth between contours now being 2.94×10^{-5} cm. instead of 2.73×10^{-5} cm. This 6 per cent. reduction of sensitivity can generally be disregarded, and where necessary an allowance can be made for it.

This improved technique has been applied by the authors to various problems, and an example was given in the note in which the improvements were described. This consisted in the examination of the effect of polishing on an alloy containing constituents of very different hardnesses. An alloy of this kind in which the differing degrees of hardness are of great industrial importance is Babbitt metal (tin base bearing metal) in which the hard constituents supported by the soft continuous base are regarded as being responsible for the qualities associated with a satisfactory bearing metal. The cast specimen of tin-copper-antimony alloy was polished and then lightly etched in 0.5 per cent. nitric acid in order to reveal the crystal structure without removing a significant amount of metal from any part of the surface.

The photographs reproduced in Plate III, show Fig. 47, an ordinary photomicrograph of the surface showing a needle of the copper-tin compound and several cubes of the tin-antimony compound, and, Fig. 48, an interferogram of the same field showing the differences of level of the compound crystals and the basis metal. A "profile" derived from the interferogram is shown in Fig. 49 as an illustration of the method of interpreting the results.

PLATE III.

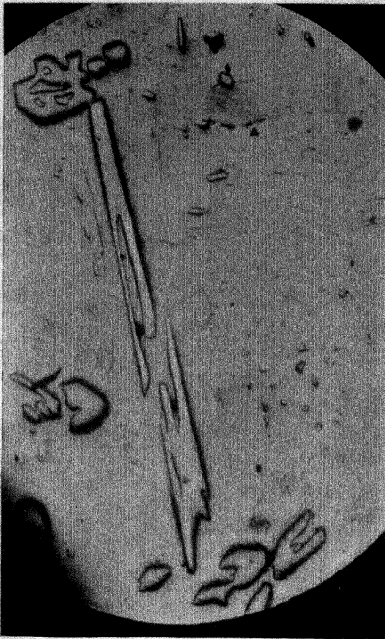

FIG. 47.



A —

— B



FIG. 49.

ETCHED BABBITT METAL.

FIG. 47.—Vertical Illumination ($\times 100$).

FIG. 48.—Interference Fringes, same Field
($\times 100$).

FIG. 49.—Transverse Section on AB (horizontal
 $\times 100$, vertical $\times 3300$).

PLATE IV.



FIG. 50.—Electrodeposited Tin, scratch-brushed ($\times 140$).

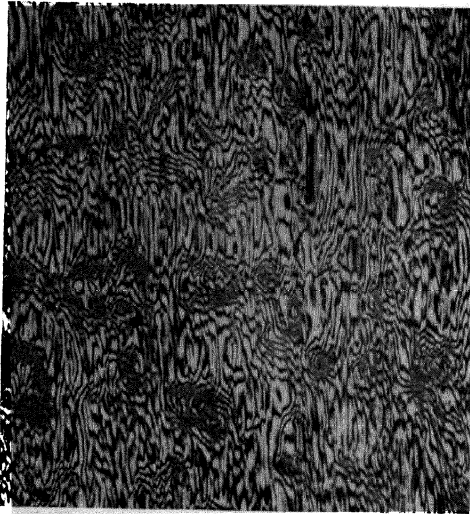

FIG. 51.—Electrodeposited Tin, polished ($\times 45$).

In the same note, the authors state that :—" In general, this technique can be applied to the study of any action which may give rise to characteristic differences of level in a surface. Irregularities caused by polishing a surface, the constituent phases of which are not of equal hardness, or caused by differential attack of etching reagents due either to distinct phases or to varying crystal orientations of the same phase or to boundary effects, are all susceptible to study by the technique. . . ."

The same technique has also been applied ¹ to the examination of the micro-topography of electroplated surfaces, and examples of the results obtained are given in Plate IV, in which the two photographs show the interference photographs obtained with, Fig. 50, scratch-brushed ($\times 140$) and Fig. 51, polished ($\times 45$) electrodeposited tin.

It may be pointed out that it is quite easy to distinguish between " hills " and " valleys," which appear much the same in an interferogram, by slightly increasing the pressure between the optical flat and the surface under examination. The fringes move as the pressure is increased, and it can easily be understood that they should move inwards to a concavity and outwards from a convexity as the flat approaches the surface.

A technique essentially similar to the one described above has been used by Iakutovitch ² for the examination of slip bands on metals that have undergone plastic deformation, but as far as can be ascertained no particular advance in methods has been accomplished.

Phillips and Pollard ³ have used a similar method for examining the shape and size of the deformation produced when a steel ball is pressed against a softer metal. The shape of the indentation and the size and shape of the raised " rim " produced by flow from the indented region are clearly revealed in this way.

The examination of the shape of sharp cutting edges is not easily accomplished by means of ordinary micrographical

¹ Hoare and Chalmers, *Trans. Electrodepos. tech. Soc.*, 1938, **14**, 113.

² See Davidenkov, *Metal Ind.*, 1937, **50**, 35.

³ Phillips and Pollard, *loc. cit.*

technique. An oblique section is liable to damage the very thin part in the neighbourhood of the extreme edge, and the magnification required is very large. The use of interference fringes has been attempted by the author for this purpose, and promising results have been obtained. In order to obtain sufficient magnification it is necessary to use an objective having a small working distance, and it has been found that an oil immersion lens is necessary. It is of course necessary to insert a glass plate between the objective and the edge, and a thin microscope cover glass is satisfactory since the use of high magnification does away with the necessity for using a piece of glass that is more than approximately flat. If the glass is in contact with the edge, then the fringes are roughly as drawn in Fig. 42a and this does not give very much information about the shape

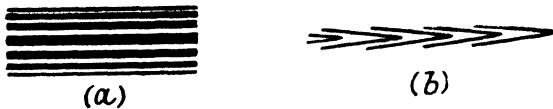

FIG. 52.—Interferograms of Sharp Edge (diagrammatic).

of the edge. If, however, the plate is tilted very slightly, so that it is only actually in contact with the edge at one point, then the appearance of the fringes is as shown in Fig. 52b, each fringe representing an oblique section of the cutting edge. Thus a very highly magnified oblique section of the edge can be obtained, the advantage being that the fringes can be observed at a part of the surface which has not been disturbed by sectioning or by the pressure of the glass plate. The application of this method to the much blunter knife-edges used for balances has been mentioned by Pollard.¹ The difficulty of the method from the point of view of technique increases in proportion to the sharpness of the edge under examination.

A much more elaborate method of examining the microtopography of surfaces such as those of length limit gauges has been described by Kinder.² This is the Linnik-Zeiss

¹ Pollard, *J. sci. Instrum.*, 1938, **15**, 37.

² Kinder, *Zeiss Nachr.*, 1937, **2**, 91.

micro-interferometer in which the optical system is that shown in Fig. 53. The source of light is condensed by means of a system of lenses so as to illuminate the two plates *R* and *S* of which one is a standard flat and the other is the surface under examination. The light reflected from the surfaces passes again through the microscope objectives *F* and *G*, after which the beam from *R* is reflected and that from *S* is transmitted by the plate *P*. The combined beam of light is then viewed through the eyepiece of the microscope at *E* or projected on to a photographic plate. The character

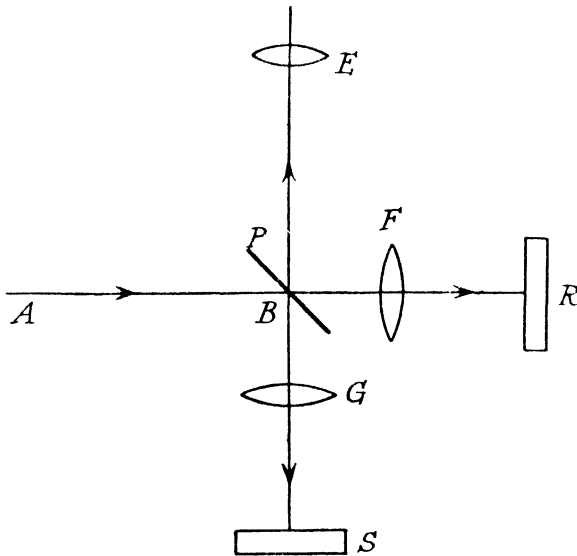

FIG. 53.—Linnik-Zeiss Micro-interferometer.

of the fringes that will be seen with a system of this kind has been discussed above (see p. 51), and it was concluded that the contrast is good but that the fringes are broad. Owing to the impossibility of obtaining narrow fringes by this method, it is doubtful if the extra contrast that is available increases the sensitivity with which depth measurements can be made. It has been mentioned, however, that the method under discussion here could be used for surfaces that reflect all the light that falls on them, whereas the very much simpler method of Hoare and Chalmers would then be impossible; this is not a serious objection to the latter method,

however, since surfaces such as that of tinplate are very easily studied by this method, and surfaces having a reflectivity much higher than this are not common.

Investigation of Film Thickness

It is a familiar fact that when light is transmitted or reflected by a thin film of a fairly transparent substance, it appears coloured. The colours of soap films and of oil on water are examples of this phenomenon. It has been recognised for a long time that these colours are caused by interference, the destructive interference of certain colours causing the complementary colours to appear. The order in which the colours appear, and the relation between the colour and the thickness of the film, have been established and accounted for.

The position with regard to the colours which often appear on metals exposed to oxidising conditions is, however, not quite so well established, although recent work has shown beyond doubt that the cause is exactly the same as in the cases mentioned above. The discussion will be taken in three parts: (1) theory of the colours, (2) proof that the theory is correct, (3) applications.

Theory : Conditions for Formation of Colours

When white light falls on a film, some is reflected from the first surface reached, some is scattered by the material of the film, some is absorbed by or transmitted through the second surface and some is reflected by the second surface. For simplicity let us first assume that the second surface is a good reflector, and that the light which falls on the film is reflected in a series of components of diminishing intensity in the manner described in the general discussion of interference fringes. The variation of intensity of reflection with film thickness depends, as before, on the number and relative intensity of the components concerned. If the light consisted only of the first and second components, of equal intensities, then the variation would be as illustrated in Fig. 54 for any one wavelength of light. The other extreme is the case in which the number of components is large, owing to the absorption being small and the reflecting powers of the two surfaces about equal and not too large. In this case

the variation of intensity of any one colour with thickness is shown in Fig. 55. It was pointed out above that this type of fringe appears to be localised in the neighbourhood of the film itself, the localisation being more definite if only a few components are involved. The colour seen at any point of the film is therefore the effect of the intensity of

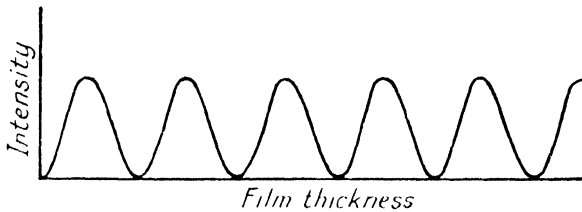

FIG. 54.—Relation between Intensity and Film Thickness for Monochromatic Light.

each wavelength present in the incident light. This will depend upon two factors: (1) which colour has its minimum intensity at the point concerned, and (2) the shape of curves relating the intensity with the thickness of the film for the other colours. The absence from white light of a very narrow band of a single colour will not appreciably alter the colour

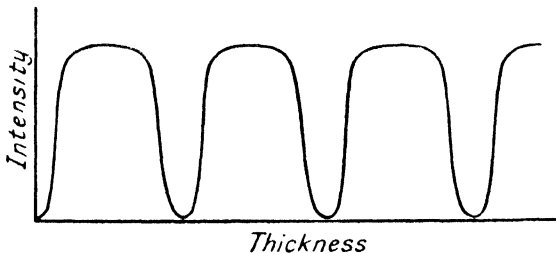

FIG. 55.—Relation between Intensity and Film Thickness for Monochromatic Light; narrow dark fringes.

of the light, but if varying amounts of other colours are also absorbed, the change of colour may become definite.

Thus for a film having a thickness such that a particular wavelength is absorbed, the variation of the intensity of the reflected light with wavelength depends upon the reflecting powers of the two surfaces and on the absorbing power of the film in the manner described above. The forms of the curves for two extreme cases are shown in Fig. 56.

Owing to the peculiarities of the physiological process of colour discrimination, the colours seen in the cases *a* and *b* may be different, although the film thickness and the wavelength of minimum intensity are the same in the two cases. In general it will be appreciated that the colours will be brighter and more clearly seen in the case *a* than in the case *b*, and therefore a strongly reflecting base and an absorbing film offer better conditions for the formation of the colours than a "clear" film on a less reflecting base. A clear film on a strongly reflecting base is less satisfactory still, no fringes being formed if the base is a perfect reflector.

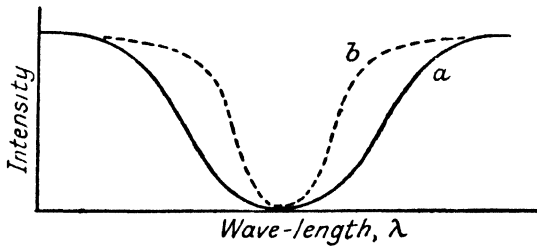

FIG. 56.—Relation between Wavelength and Intensity of Reflected Light.

Relation between Thickness and Colour

In view of the considerations detailed above it is desirable to discuss the relation between the wavelength of minimum intensity and the film thickness, rather than between colour and thickness. The condition for destructive interference is that the first two reflected components should be out of phase with each other on reaching the eye. This means that the path of one ray must be longer than that of the other by an odd number of half-wavelengths, any phase change introduced by the reflections (see p. 37) being regarded as part of the path difference. If we represent this additional path difference by *c*, and the thickness of the film by *t*, the reflection will have a minimum intensity when

$$2t + c = \frac{\lambda}{2}, \frac{3\lambda}{2}, \frac{5\lambda}{2}, \text{ etc.}, \text{ i.e.}, t = \frac{\lambda}{4} - \frac{c}{2}, \frac{3\lambda}{4} - \frac{c}{2}, \frac{5\lambda}{4} - \frac{c}{2}, \text{ etc.}$$

The value of *c* is open to some doubt, and seems to depend upon the conditions governing the reflections; but in certain cases its value can be assumed with reasonable certainty.

For this purpose it is necessary to differentiate as follows between different cases that arise :

- (a) film on reflecting base viewed by reflection ;
- (b) film on non-reflecting base viewed by reflection ;
- (c) film on non-reflecting base viewed by transmission.

A probable value of c can be deduced by considering the conditions obtaining if the thickness of the film is reduced to zero.

(a) A film of zero thickness on a reflecting base would have no effect on the light reflected and so a maximum reflection should occur at $t = 0$. Maxima correspond to

$$t = 0 - \frac{c}{2}, \frac{\lambda}{2} - \frac{c}{2}, \lambda - \frac{c}{2}, \text{ etc.}$$

hence if $t_0 = 0$ then $c = 0, \lambda, 2\lambda, \text{ etc.}$, or the equivalent path difference due to the reflection is a whole number of wave-lengths and therefore does not alter the phase relation. Thus we conclude that the value of c may be taken as zero when the film is vanishingly thin, and it is assumed on this basis that the value of c is still zero when the film has a finite thickness.

(b) This is the case of a film on a transparent base, and here the value of c probably depends on the nature of the media on the two sides of the film. When these are the same, as in a soap film, then light would be totally transmitted, with no reflection, if the thickness of the film were reduced to zero.

Thus for case (b) the intensity of the reflected light would be zero for zero thickness of film, or the condition

$$t = \frac{\lambda}{4} - \frac{c}{2} \text{ is satisfied for } t = 0.$$

Thus the effect of the reflection is to introduce an extra path difference of $\frac{\lambda}{2}$.

(c) In this case the transmission is a maximum when $t = 0$ so $t = 0 - \frac{c}{2}$, and as in case *a* the phase change is taken as zero.

Cases (b) and (c) need reconsideration when the media on

the two sides of the film are different, because the foregoing analysis only applies when the reduction of the film thickness to zero leaves no surface at which reflection can take place. When the two media are different a surface is left when the film is reduced to zero thickness, and reflection may still take place. This may be regarded as corresponding to an intermediate value of c between 0 and $\frac{\lambda}{2}$, the actual value depending on the difference between the media.

Except in special cases which will be considered below, the films under discussion are those formed on metal bases, where the reflecting power is good. In these cases, which come under group (a), the value of c will be taken as zero.

The relation between thickness and minimum reflection is then $t = \frac{\lambda}{4}, \frac{3\lambda}{4}, \frac{5\lambda}{4}$, etc., where λ is the wavelength in the material of the film of the light which is reflected minimally. The wavelength in the film λ is connected with the wavelength in air λ_0 , by the refractive index n , the relation being $n = \frac{\lambda_0}{\lambda}$.

The value of n is not as a rule constant but depends on λ_0 . Since the colour depends on λ_0 rather than on λ , it is better to express the condition for minimum reflection as $t = \frac{\lambda_0}{4n}, \frac{3\lambda_0}{4n}$, etc., the appropriate value of n being used.

It was pointed out by Evans¹ that the variation of n with λ might influence the colour to be seen even if other conditions are fixed; the curve a of Fig. 54 is a symmetrical curve for wavelengths measured in the film material. But if n varies with λ_0 , then λ is not proportional to λ_0 and if the curve is replotted using λ_0 instead of λ , it will become unsymmetrical. This would result in a change of colour.

Since the condition for destructive interference is known, it is possible to calculate the wavelength for any given thickness of film, so long as the refractive index of the film material is known. The order of colours in the spectrum is shown in Fig. 1 (p. 2) together with a rough scale of wavelengths in

¹ Evans, *Metallic Corrosion, Passivity and Protection*, Arnold, 1938.

centimetres. If the film is regarded as increasing in thickness from zero, it will not show any colour effect until the first absorption band, corresponding to $t = \frac{\lambda}{4}$, begins to reach into the violet of the spectrum. If the band is a broad one, as in Fig. 54a, then this will happen while the centre of the band is still in the ultra-violet region. When the blue end of the spectrum is missing, the colour that results is yellow or brown. If the thickness is further increased, the absorption band moves towards the longer wavelength end of the spectrum. When the centre of the band is in the blue, the colour seen will be red, or if the band is narrow, a mauve tint. As the band moves to the left in the following table the colour will change as shown. The colours given are only rough indications because the width of the band controls the actual characteristics of the light. The table shows the series of colours of the first order.

Centre of absorption band	Red	Orange	Yellow	Green	Blue	Violet
Colour seen	Green	Blue	Blue-violet	Red-violet	Red	Yellow-brown

It follows from the fact that a number of different values of the wavelength can satisfy the condition for extinction that more than one absorption band may be present in the visible spectrum. Since extinction occurs when $t = \frac{\lambda}{4}, \frac{3\lambda}{4}, \frac{5\lambda}{4}$, etc., it follows that, for a given value of t , the following wavelengths are able to satisfy the condition:—

$$\lambda_1 = 4t, \lambda_2 = \frac{4t}{3}, \lambda_3 = \frac{4t}{5}, \text{ etc.}$$

Since the wavelengths at the two ends of the visible part of the spectrum are in the ratio of approximately one to two, it follows that λ_1 will be beyond the red end of the spectrum while λ_2 , of one-third the length, is still in the ultra-violet. If the bands are of moderate width, the effect of the first will

cease just as the second becomes perceptible ; this explains why the first order colours show the complete sequence. If the bands are narrower than this, the band due to λ_1 will pass out of the red end of the visible spectrum before the effect of λ_2 enters the violet end. In this case the succession of colours discussed above will be followed by a condition in which no colours are formed. This is known as the silvery hiatus between the first and second orders. The second order of colours is due to the effect of λ_2 , and it is evident that the complete array of colours will not be seen in the second order because λ_3 will begin to affect the short wavelength end of the spectrum before λ_2 has left the red end. The same consideration applies to higher orders of colours and as the wavelengths of the centres of the absorption bands are in the ratio of $1 : \frac{1}{3} : \frac{1}{5} : \frac{1}{7}$, etc., it follows that for a thicker film there may be several absorption bands in the visible spectrum at once, and this causes the complete or partial disappearance of colours beyond the fourth order. The accompanying table, quoted from U. R. Evans, *Metallic Corrosion, Passivity and Protection*, shows the sequence of colours for films of various materials. The first two columns refer to air films, the colours formed by reflection and transmission being given in order to show their complementary relation.

The difference in the colour sequences in the columns that refer to films on metals may be due to the differing widths or shapes of the absorption bands, or may be due in part to specific colours of the oxide films. If an oxide film has a specific colour, this is equivalent to the existence of an extra absorption band which does not move as the thickness of the film is increased. -

U. R. Evans ¹ has perfected a technique whereby the oxide films can be transferred to a transparent support from the metal on which they form. The colours can then be viewed by transmitted light as well as by reflected light, and it is found that the colours seen by reflected light without the metal support are very nearly but not quite complementary

¹ U. R. Evans, *Iron and Steel Inst.*, Fifth Report of the Corrosion Committee, Section D, part 2, 1938, p. 225.

NEWTON'S RINGS			FILMS ON METALS			
	Reflected.	Transmitted.	Oxide on Lead or Nickel; Iodide on Silver; Hydroxide on Aluminium.	Oxide on Iron.	Oxide or Sulphide on Copper.	
Invisible	Black	White	Colour of metal unchanged			
1st Order	Blue Faint green Yellow Red	Yellow Red to mauve Blue Green	Yellow to brown Rose to mauve Blue Silvery or greenish	Yellow to brown Mauve Blue Silver grey	Brown Rose to mauve Blue Silver	
2nd Order	Blue Green Yellow Red	Yellow Red Blue Green	Yellow to brown Red Blue Green	— Pinkish blue Blue Greenish blue	Yellow-brown Red Blue Green	
3rd Order	Blue Green Yellow Red	Yellow Red Greyish blue Green	Yellow Red Trace of lavender blue Green	— Bluish grey with trace of pink Bluish grey (speci- fic colour)	Brown Red Trace of lavender blue Green	
4th Order	— Green Red	Dull yellow Red Green	Red Green	" " "	— Dirty red Dirty green	
5th Order	Greenish	Red	—	"	Grey (sometimes trace of red)	

to the colours seen before the support is removed. The reason for the difference caused by the presence or absence of the metallic support is that the phase change C is zero for an unbacked film, and $\frac{\lambda}{2}$ for a film with reflecting back.

As a result of this change of effective path difference of λ , a wavelength for which the two primary interfering beams are out of phase, and is therefore the centre of an absorption band for the unbacked film, will be reflected with maximum intensity for the film with a reflecting back. Thus, for a given thickness of film the maxima of one will occur at the same wavelengths as the minima of the other, and the obvious conclusion is that the colours are complementary. This is not quite the case, however, because, as pointed out previously, the colour depends on the characteristics of the absorption band as well as on the position of its centre. The analysis applied to interference fringes in general shows that the contrast and width of the fringes will depend to a considerable extent on the reflecting power of the second surface. This is reduced from a high to a low value by removing the metal backing from the film, and it is not therefore to be expected that the colours should be exactly complementary. The existence and reason for this departure from the strictly complementary relationship were pointed out by U. R. Evans.

An interesting observation has been made by U. R. Evans (*loc. cit.*) in connection with the oxide film on iron, where a layer of magnetite may be present between the ferric oxide which is responsible for the film colours and the iron base. It was found that the second order colours are generally very much less conspicuous than those of the first order, and that the third order colours could only be seen from the "top" of the film and not from the side from which the iron had been removed. When the colours were observed through the celluloid on to which the film had been transferred, those of the second and third orders were the same as they had been before removal of the backing metal, whereas the first order colours had changed to the complementary series owing to the removal of the reflecting backing layer. This observation is taken to support the view that the films which are

transferred to the celluloid are the actual oxide films from the metal.

Reference has already been made to a very important principle in connection with interference phenomena, *i.e.*, that no light is ever destroyed by interference, and that the light which is apparently missing as a result of interference appears in some other direction. An example is that if a film (on a transparent base) is viewed by reflection, certain colours will be absent, and the appropriate complementary tint will appear; if the same film is viewed by transmission, the colour will be complementary to that seen by reflection. Thus the light which is missing from the reflected beam is present in the transmitted beam, and *vice versa*.

This principle was regarded as the basis of an objection to the theory which accounts for the production of colours on metals as an interference phenomenon. It was pointed out that since the metal base would reflect the light that reaches it, no interference effect should be observed. It has been shown in the discussion of the theory of the production of interference fringes (*vide supra* p. 50) that interference effects will in fact occur if the reflecting power of the second surface (*i.e.*, the metal base) is less than unity, or if the material of the film absorbs or scatters light. If scattering in the film is the operative factor, then the scattered light should show colours complementary to the interference colours under discussion, and it is often found that if a film is viewed in a direction such that none of the regularly reflected light is received, then the colour of the scattered light is complementary to the interference colours as seen in the usual way. A particularly striking example of this phenomenon is to be observed when tin is maintained at a temperature above its melting point for a sufficient time for the colours to appear, and is then cooled.

We have so far confined the discussion to light which is incident normally on the surface. When this is not the case, other considerations become important, particularly in connection with the effect of changing the angle of incidence on the colour of the film.

The effects which may occur are three: (a) the effect of

altered path difference on the wavelength of maximum absorption ; (b) the effect of increased reflectivity at high angles of incidence ; (c) the polarising effect of oblique incidence. These three effects will be considered in turn.

(a) *Path Difference.*

It can easily be proved that the relation between film thickness t , angle of incidence I and wavelength of first interference minimum λ_1 , is

$$\lambda_1 = 4t \sqrt{n^2 - \sin^2 I}$$

where n is the refractive index of the material of the film. Taking the extreme case, that in which $I = 90^\circ$, *i.e.*, where the incident ray is at grazing incidence, the percentage difference in λ_1 between $I = 0^\circ$ and $I = 90^\circ$ is given for various values of the refractive index, n ,¹ in the accompanying table.

n	% change in λ_1
1.5	21
2.0	13.5
2.5	8.4
3.0	5.7

For the case $n = 2.5$, the variation of colour with angle of incidence can be considered as follows. Let $\lambda_1 = 4 mt$, then m is equal to n at $I = 0$, and its values at other angles of incidence are given in the table

I	m
0°	2.5
20	2.48
40	2.42
60	2.36
80	2.31
90	2.29

¹ The refractive indices of copper oxide, iron oxide and nickel oxide for light of wavelengths 4500 Å (blue) and 7000 Å (red) are given by Kundt as follows : 3.1, 2.6 ; 2.3, 1.75 ; 2.4, 2.2 (Kundt, *S. B. preuss. Akad. Wiss.*, 1888, 268).

It follows that, for a non-dispersive medium of refractive index 2.5, the change of λ_1 with I is small. In fact, an application of the figures given above shows that a film of thickness 600 Å and refractive index 2.5 will have an absorption at 6000 Å for normally incident light and at 5496 Å for light at grazing incidence. It is interesting to note that although the light travels farther in the film when the incidence is oblique, this is more than compensated by the extra distance that the ray reflected from the upper surface travels in air, and the film behaves as if it were thinner than for normal incidence.

The media actually concerned, namely the oxides of iron, nickel and copper, etc., are all dispersive, *i.e.*, the refractive index changes with the wavelength, the changes being in opposite senses. The result is that the change of λ_1 with angle of incidence is less than the value calculated for a non-dispersive medium.

(b) *Effect of Angle of Incidence on Reflectivity of Front Surface.*

The brightness of the colours depends on the sharpness and contrast of the absorption bands, and both of these factors depend on the reflectivities of the two surfaces, and on the absorption of light by the film. The effect of increasing the angle of incidence is to increase the reflectivity of the upper surface (the reflecting power of the surface of any transparent material increases as the angle of incidence is increased) and to increase the amount of light absorbed by the film owing to the greater distance of film to be traversed. The result of both these effects will be to decrease the contrast of the fringes, thereby rendering the light less coloured, and to broaden the absorption bands, thereby slightly altering the colours.

(c) *Effect of Polarisation at Reflection.*

When light is reflected from a surface, the incidence being oblique, the incident light must be considered as consisting of two coincident beams of light, one polarised in the plane of incidence, the other in a plane perpendicular to it.¹ These two components are changed differently by reflection, as regards both intensity and phase. The changes which take place depend upon the optical characteristics of the reflecting

¹ For an explanation of these terms, see Chapter 5, p. 117.

surface, and will be different for the two surfaces concerned, namely, the oxide surface and the metal surface. Thus the phase difference c introduced by the reflections cannot be assumed to be zero for both components at all angles of incidence. Changes in the value of c will alter the wavelength that is absorbed and will consequently alter the colours.

The following observations show that the value of c is in fact different for the two components, which can be examined separately by viewing the surface through an analyser such as a nicol prism or polaroid. At normal, or nearly normal incidence, the colour is unaltered by the extinction of any component of the light. If the angle of incidence is increased, the chief effect of examining the surface so that only one component of the light is received is to alter the brightness but not the colours. This is due to the fact that the specular reflection from the upper surface, which tends to predominate over the colours, is largely absorbed when the analyser is set in a suitable azimuth. If the analyser is set in this way, and the angle of incidence is increased considerably, it is found that the colours change rather suddenly to their complementary colours when a definite angle of incidence is exceeded. These facts can be applied to the measurement of the refractive index of the material of the film in the following way. It can be shown that the light reflected from a surface contains an excess of light polarised in the plane of incidence, while the refracted light contains an excess of light polarised in a direction perpendicular to this. The phase change which takes place at reflection depends upon the angle of incidence and on the optical constants of the reflector, and will in general be different for the metal and the oxide surfaces. The change of phase is less for light polarised at right angles to, than for light polarised in, the plane of incidence. It was shown by Jamin, moreover, that for transparent substances, the phase difference between the two beams is small for angles from normal incidence nearly up to a particular angle of incidence, the polarising angle I_p , which is connected with the refractive index n by the relation $\tan I_p = n$. At the polarising angle, the phase difference is very nearly 90° , and at a slightly greater angle it becomes almost 180° .

If, therefore, the colours are observed through an analyser set so as to absorb the light that is reflected specularly, and the angle of incidence is increased, the angle at which the colours suddenly change is the polarising angle. If this angle is measured, the refractive index can be determined approximately. If monochromatic light is used the value can be measured with greater accuracy, and if several wavelengths are used, the dispersion can also be found. The importance of this measurement is that the absolute value of the thickness of a film can only be calculated from the colour if the refractive index is known. The change of colour due to observation by polarised light at oblique incidence was pointed out by Mallock,¹ who did not, however, offer any satisfactory explanation for it.

Applications.

The estimation of the thickness of oxide films by interference colours was first attempted by Tamman, who used the colour as a direct indication of the thickness. It is pointed out by Evans, however, that this cannot give more than a rough indication unless three conditions are satisfied :

- (a) the effective additional path difference C due to reflection is zero ;
- (b) the position of the centre of the absorption band alone determines the colour sensation ;
- (c) the refractive index is independent of the wavelength.

Since these three conditions are certainly not satisfied in practice, the simple method can only be applied approximately. It is, however, possible to prepare tables of the colour-film thickness relationships for the various oxide films for which the refractive index is known, and the following table ² gives these figures for copper, iron and nickel. It will be seen that the colour sequences are not exactly the same in the three cases.

An indirect, but very important and well-known application of this effect is the use of colours in estimating the temperature in heat-treating steels. This is based upon the fact that the colour, and therefore the film thickness, depends far

¹ Mallock, *Proc. roy. Soc.*, 1918, **94**, 561.

² Constable, *Proc. roy. Soc.*, 1927-8, **117**, 376.

THICKNESS OF OXIDE FILMS ON CU, NI AND STEEL

	Copper Oxide Film.		Nickel Oxide Film.		Iron Oxide Film.	
	Colour.	Thickness of homogeneous film of same colour.	Colour.	Thickness.	Colour.	Thickness.
<i>1st Order</i> . . .	Dark brown . . .	A.U. 380	Pale brown .	A.U. 490	Straw .	A.U. 460
	Red brown . . .	420	Dark brown .	540	Reddish yellow	520
	Very dark purple .	450	Purple . . .	570	Purple .	630
	Very dark violet . .	480	Very dark violet	600	Violet .	680
	Dark blue	500	Very dark blue	760	Blue. . .	720
	Pale blue-green . . .	830	—	—	—	—
<i>2nd Order</i> . . .	Pale silvery green .	880	Silvery green .	1120		
	Yellowish-green . .	970	Yellow-green .	1200		
	Full yellow	980	Yellow	1260		
	Old gold	1110	Straw	1350		
	Orange	1200	Yellow-brown .	1620		
	Red	1260	Dark brown .	1720		

more on the temperature than on the time for which the temperature is maintained. Although the film thickness increases with time at a constant temperature this is so slow that the temperature is shown accurately enough for many purposes by the colour. The temperatures corresponding to various colours are estimated slightly differently by various authorities, and these differences are probably due to the different brightness and colour of the light by which the observations were made. The composition of the steel does not seem to have a large effect on the values, although the method cannot be used for certain types of steel. The table gives values which appear to apply to average conditions of observation.

	° C.
Very faint yellow	216
Light straw	221
Light yellow.	226
Pale yellow straw.	232
Straw	238
Dark yellow.	243
Deep straw	248
Yellow-brown	254
Brown	265
Brown purple	271
Light purple.	277
Purple	283
Dark purple.	294
Light blue	294
Blue	300
Dark blue	315
Blue tinged with green.	330

It is unnecessary to deal here with the decorative applications of heat tinting, to which the above considerations apply unchanged.

An interesting piece of work in which the estimation of film thickness by means of colour is described in a paper by Miley¹ who, in describing an electrical method for measuring the thickness of oxide films on copper, compares his values with the values found by Constable² for the various colours

¹ Evans and Miley, *Nature*, 1937, **139**, 238 ; Miley, *loc. cit.*

² Constable, *Proc. roy. Soc.*, 1927-8, **117**, 376.

of the series. These values, which are in strikingly good agreement, are reproduced here.

Colour.	Electrical A.U.	Optical A.U.
<i>1st Order.</i>		
Dark brown	370	380
Red brown	410	420
Purple	460	450
Violet	485	480
Blue	520	500
Silvery green	800	880
<i>2nd Order :</i>		
Yellow	940	980
Orange	1170	1200
Red	1240	1260

It is pointed out in Miley's paper and elsewhere that there are various ways in which the average thickness of a film can be expressed if the film or the underlying surface is not uniform. The mean thickness is here taken as the average



FIG. 57.—Thickness of Film.

of a large number of values of the thickness as measured perpendicular to the general direction of the surface (Fig. 57 (a)). This is a good approximation to the measurement that is made by the optical method, and is greater than the thickness as measured by the mean of the lengths of the perpendiculars to the "local" surface (Fig. 57 (b)). The extent of this difference depends on the degree of irregularity of the surface.

Using the method mentioned above, Miley showed that both the oxides of copper are concerned in the production of the colours. Films with colours up to the middle of the second order are chiefly composed of cuprous oxide, while those having colours of higher order are overlaid with a layer of cupric oxide which tends to obscure the colours. Until

a sufficient thickness is attained for a distinct layer of cupric oxide to form, however, the film, which may contain both oxides, behaves as a single film and gives the characteristic interference colours.

In an investigation of the atmospheric tarnishing of silver and silver alloys, Price and Thomas¹ used the observation of interference colours as a method for estimating the thickness of the sulphide layer formed under various conditions. For convenience they usually expressed the thickness in terms of that of a cuprous oxide film on copper which showed the same interference colour. These investigators estimated that the thickness could be determined to an accuracy of about 10 per cent. by this method, and they point out that it has the advantage of being rapid and of allowing the thickness to be determined at any point. These films, when formed by natural atmospheric tarnishing, usually remain sufficiently transparent for the production of colours up to the third order of interference colours.

Certain cases have been mentioned in which interference colours have not been observed when the film is known to be of an appropriate thickness for their production. Price and Thomas, for example, state that no colours were formed, in certain cases, when the film is formed on a polished surface, but that when an abraded surface was used, the colours appeared. An observation by Vernon² that no colours were formed when films are formed on iron below 200° C. may be connected with this, although Vernon explains it as a result of the film being too opaque or fragmentary under these conditions. It appears more probable, however, that the absence of the colours in the cases cited by Price and Thomas is due to the fact that if a very transparent film is formed on a good reflecting surface, the absorption band may be too narrow and not sufficiently "deep" to allow the colours to become visible. The absorption band that would be produced under such conditions (reflecting power of second surface large, absorption small) is shown in Fig. 58. This is characteristic of conditions of small contrast and small width of

¹ Price and Thomas, *J. Inst. Met.*, Aug. 1938, **63**, Advance copy.

² Vernon, *Trans. Faraday Soc.*, 1935, **31**, 1668.

absorption band. If, however, the surface were abraded slightly before oxidation, its reflecting power would be considerably reduced. This would result in the reduction of the

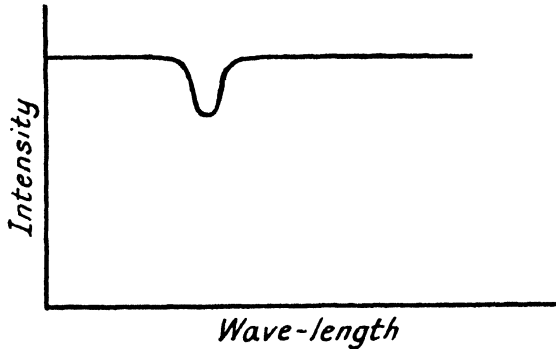

FIG. 58.—Absorption Band for Transparent Film on a highly Reflecting Surface.

second and subsequent terms in the series that are responsible for the interference effect (see p. 44) and the consequence would be an increase of contrast and a broadening of the absorption band, as illustrated in Fig. 59.

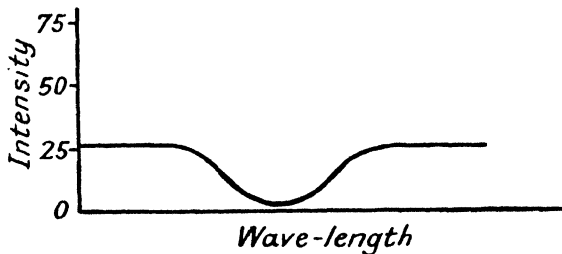

FIG. 59.—Absorption Band for Film on moderately Reflecting Surface.

Verification of Theory

The most complete experimental study of the interference colours on metals is that of Constable,¹ who examined spectroscopically the light reflected from metal surfaces showing interference colours. It was found that an absorption band occurred in the spectrum, and that if the metal were treated so that further oxidation took place, the absorption band moved towards the red end of the spectrum. The centre of

¹ Constable, *Proc. roy. Soc.*, 1927-8, 115, 510 ; 117, 376.

the absorption band is the wavelength that satisfies the condition of destructive interference, and if the refractive index for every wavelength is known, the thickness can be calculated. Using Kundt's values for the refractive index of the oxide (measured on the oxide in bulk) and Kanaby's figures for dispersion, Constable calculated the thicknesses corresponding to various colours, using the spectroscopic values of the centres of the absorption bands.

Constable also verified that the colours depended upon the thickness of the oxide films by measuring this thickness (*a*) by the reduction of pressure of the oxygen in a closed vessel in which the oxidation took place and (*b*) by the change of electrical resistance of the oxide film. The three methods of determining the thickness gave satisfactorily concordant results.

Colours of Metal Films

A considerable amount of work has been done on the colours of films of metals, and it all supports the conclusion that the colours are due to interference. Overbeck,¹ for example, has shown that the colours of a film of tin produced by sputtering are due to interference, and not, as suggested by R. W. Wood, to some other cause. Nathanson² has used the interference colours of sputtered aluminium and manganese films as a measure of their thickness. By using light of different wavelengths he investigated the variation of refractive index with wavelength. The results are of interest because they indicate that while the refractive index increases with wavelength for the metal in bulk, the reverse is true when the metal is in the form of films. It should be observed that the last two investigations are concerned with thin films of metals, and not with oxide films as in the previously discussed investigations. A necessary condition for the production of colours in this way is that the material concerned should transmit a fair proportion of the incident light through a thickness equal to at least one wavelength in the material of the film. It is interesting to note that a good many metals as well as a number of oxides are able to do this.

Investigations on the interference colours produced by a

¹ Overbeck, *J. opt. Soc. Amer.*, 1933, **23**, 109.

² Nathanson, *ibid.*, 388.

film of one metal on another have also been made by Prosad and Ghosh¹ and Edwards.² Prosad and Ghosh, extending earlier work, investigated the colours of the films which form by sputtering in X-ray tubes. Using a platinum anticathode and an aluminium cathode, they found that the sputtering effect caused a deposit of platinum to form on the cathode. The film showed coloured rings which were proved to be consistent with the explanation in terms of interference fringes, and the refractive indices of the film were determined for two colours. The values obtained indicated that the refractive index of the material forming a very thin film is different from the value for the material in bulk. This conclusion is supported by the results of Summers,³ who worked with the polarised light method on thicker films. Edwards investigated the conditions necessary for the formation of interference colours in thin metal films produced by sputtering. The following conditions were found to apply :

- (1) Colours are only formed when the film is thin enough to be transparent.
- (2) The colours are most pronounced when the film is formed on a base of a "white" metal.
- (3) Several orders of interference fringes can often be observed if monochromatic light is used.
- (4) The intensity of the fringes at first increases and then decreases as the order is raised.
- (5) The colour of the film (viewed by white light) depends upon the angle of incidence, but a change of 70° to 80° is necessary for any change to become noticeable.
- (6) The cycle of colours is much the same for all the metals used.
- (7) The thickness of the film of a given metal that shows a given colour depends on the metal which forms the base.

A theoretical explanation of all these results is advanced, and details are given for calculating the phase change which takes place at each reflection and refraction. The total of

¹ Prosad and Ghosh, *Indian J. Phys.*, 1936, **10**, 49.

² Edwards, *Phys. Rev.*, 1931, **38**, 166.

³ Summers, *J. opt. Soc. Amer.*, 1934, **24**, 261.

these phase changes, five in number, determines the effective phase change C which has to be considered when the relationship between colour and thickness is calculated. The theoretical treatment is not complete because no mention is made of the different behaviour of the two polarised components at high angles of incidence (see p. 88).

One of the objections that has been raised to the explanation of all these colour effects by interference has already been considered. That is the theory that a reflecting second surface would prevent the formation of interference effects. A second objection, raised by Mallock,¹ was that if the colours are caused by interference, then they should be altered by reducing the thickness of the film by abrasion. Mallock was unable to do this, and concluded that the colour was not determined by the thickness but by the size of the particles forming the film. Gale,² however, has succeeded in reducing the thickness of such a film by grinding, and he found that the colour change which accompanied the reduction of thickness was in the direction demanded by the interference theory. Evans,³ similarly, has reduced the thickness of oxide films on iron by cathodic treatment in dilute hydrochloric acid, and a similar change of colours results. It has recently been observed by the author that if copper that has been coloured by heating in air is heated in palm oil, a colour change takes place that exactly reproduces, in reversed order, the changes that take place during heating in air. This is due to the solution of the oxide responsible for the colours in the hot palm oil, and is therefore associated with a progressive reduction in the thickness of the film. The probable explanation of Mallock's failure to get changes of colour is that his process of abrasion caused the film to crack and that the removal of fragments was the only result.

Other Applications

The interference fringe method has also been applied to several types of measurement that are not covered by the three classifications already dealt with.

¹ Mallock, *Proc. roy. Soc.*, 1918, **94**, 561.

² Gale, *J. Soc. Chem. Ind.*, 1924, **43**, 349.

³ Evans, *Proc. roy. Soc.*, 1925, **107**, 230.

Thickness of fine Wires or Foils

Thickness of a fine wire or foil can be measured by forming an inclined plate interferometer with two plates of glass in contact at one edge and separated by the object to be measured at the other. If the usual system of vertical illumination is used and the fringes are observed by means of a travelling microscope of low magnification, the diameter of the wire or thickness of the foil occupying the position A (Fig. 60) can be found. Each fringe corresponds to an increase of separation of $\frac{\lambda}{2}$; if sodium light of wavelength 5.890×10^{-5} cm.

is used, each fringe represents 2.94×10^{-5} cm. If 100 fringes are counted between A and B, the separation at A is 2.94×10^{-3} cm. = 0.02 mm. If the thickness is too great for the fringes to be conveniently counted, then the number of fringes can be estimated by using an eyepiece scale in the microscope,

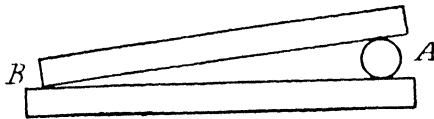

FIG. 60.—Interference Micrometer.

or else by measuring the space occupied by, say, ten fringes, and also measuring the total distance (AB) occupied by fringes. This only gives an accurate result if both the glass plates are flat; the former method (*i.e.*, that of counting all the fringes) will give a correct result whether the plates are strictly flat or not. The possibility of deformation of the object to be measured must not be overlooked, and another possible source of error is lack of perfect contact between the plates at B. Since an apparent path difference of $\frac{1}{2}\lambda$ is introduced by the reflections (see preceding section) a dark fringe is formed at B, and the number of dark fringes between A and B should be counted for an accurate result.

Thickness of Electrodeposited Layers

The absolute measurement of the thickness of an electrodeposited or hot dipped layer of one metal on another can be made in various ways, and until recently the majority of

these were chemical and involved the assumption that the metal as present in the film has the same density as in bulk. Recent work has evolved several physical methods which, in addition to being non-destructive, have the advantage of making the measurement at a small chosen locality.¹ These methods require calibration, and the successful use of interference fringes for this purpose indicates a further possibility for their utilisation.

The use of interference fringes for calibrating a magnetic instrument has been briefly described by Chalmers²; the following method was adopted. The tin coating of a specimen of hot dipped tinplate was abraded and polished so that a ramp-like transition was formed between the uncovered basis metal and the original tin surface (Fig. 61). This is shown with the thickness greatly exaggerated, in the diagram. A glass flat is held in contact with the specimen so that it is

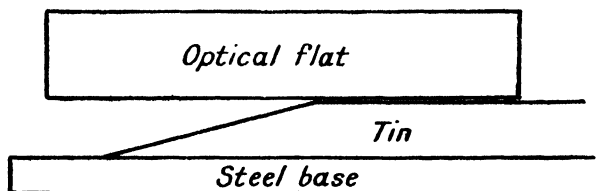

FIG. 61.--Measurement of Coating Thickness.

parallel to the surface of the steel base; this is facilitated by removing the tin in the manner shown from a region whose width is less than that of the optical flat, which then rests on the original surface on three sides of the region under examination. The interference fringes formed between the flat and the "ramp" are observed in the usual manner, and if their positions are measured with a travelling microscope, the actual shape and size of the "ramp" can be plotted. This may be compared with the results given by the instrument to be calibrated, a series of readings at known points on the ramp being taken for this purpose. It may be pointed out that the

¹ Chalmers, Hoare and Tait, *Int. Tin Res. and Develop. Council*, Tech. Publ. A66.

² Chalmers and Hoare, *Trans. Electrodepos. tech. Soc.*, 1938, **14**, 113 (Discussion).

interference fringe method as described here is particularly well suited to the examination of hot dipped and electro-deposited coatings, as the unit of measurement, *i.e.*, the half-wavelength (3×10^{-5} cm. approx.) is a reasonable unit in which to measure these thicknesses. An average tinplate may carry a thickness of 0.0001 in. or .00025 cm. or 2.5×10^{-4} cm. This corresponds to $\frac{2.5 \times 10^{-4}}{3 \times 10^{-5}} = 8$ fringes approximately. In tinplate parlance, a fringe represents about 2 ounces per basis box.

The rather more difficult task of measuring the thicknesses of the component parts of composite coatings can also be

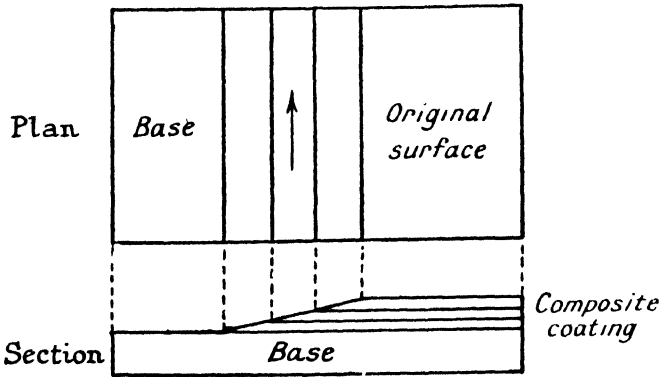

FIG. 62.—Examination of Composite Coatings.

carried out in the same way. A ramp-like surface must be produced by means of a suitable grinding technique. The details of this technique will depend on the particular components that are present, but it is advisable to avoid smearing of one metal over another by making the main direction of abrasion at right angles to the slope of the ramp. This is shown in Fig. 62. It is not necessary to produce a flat surface by means of this process, but it must be polished sufficiently well for the interference fringes to be readily observed. The different metals which form the coating, as well as the base metal itself, can usually be distinguished from each other quite easily in either sodium yellow, mercury green, or cadmium red light. This facilitates the determination of the thickness of each layer.

Elastic Constants

A method of measuring the elastic constants of glass, originated by Cornu,¹ and described from the point of view of experimental technique by Searle,² is well adapted for similar measurements on metals. The process depends on bending or twisting the specimen, which must be a flat bar, and observing the interference fringes formed between a portion of the bar and an optical flat that rests on it. In order to measure Young's modulus and Poisson's ratio the specimen SS (Fig. 63) is supported on two knife-edges AA,

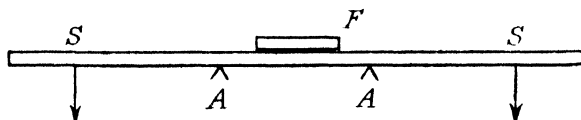

FIG. 63.—Measurement of Elastic Constants.

and equal loads are applied near the two ends. The portion of the surface on which the optical flat *F* rests must be polished so that it is as nearly plane as possible. Interference fringes formed between the optical flat and the surface of the specimen indicate the curvature of the specimen in the directions parallel and perpendicular to the axis of the specimen. The ratio of the curvatures depends upon the value of Poisson's ratio, and the value of Young's modulus can be found from the value of the longitudinal curvature. For details of the experimental method and of the method of calculating the values of the two elastic constants, the reader is referred to the description cited.

A similar method is described in the same place for measuring the modulus of rigidity by observing the interference fringes between a flat glass plate and the surface of the specimen when it is subjected to twisting forces.

These methods do not appear to be susceptible of great accuracy, and their use is not recommended for general purposes. In particular cases, however, they may be more convenient than other methods which are more generally used.

¹ Cornu, *C. R. Acad. Sci., Paris*, **69**, 333.

² Searle, *Experimental Physics*, Cambridge, 1934, p. 89.

CHAPTER 4

WAVE OPTICS. II: DIFFRACTION

A second group of effects that depends on the mutual destruction of waves at points at which they are out of phase are classified as diffraction. Diffraction is the name given to the effects that may be observed when part of a wavefront is obstructed and the remainder of the light is examined. The distribution of the light in such cases cannot be accounted for by the laws of geometrical optics, and it will be considered here from the point of view of the wave theory. The examples given below illustrate the nature of the phenomenon and some of the uses to which it can be put.

Shadow of Single Edge

A simple case of diffraction is that in which part of a plane wave front is cut off by an obstruction having a straight edge.

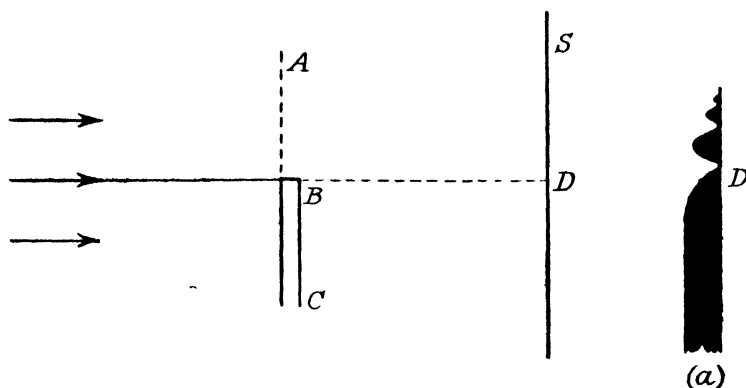

FIG. 64.—Diffraction at an Edge.

The beam of parallel light (*i.e.*, beam of light having a plane wave front) is obstructed at BC (Fig. 64). The light falling on the screen S would be expected, by geometrical con-

siderations, to be uniform above D and zero below it, with a perfectly sharp edge separating the two regions. Instead, however, the edge of the shadow is found to be marked with a series of fringes just outside the geometrical shadow, and a gradual change of brightness just inside it. This is shown diagrammatically in Fig. 64 (a). These phenomena can be observed with a slit A (Fig. 65) in front of the monochromatic

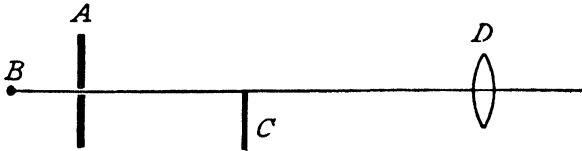

FIG. 65.—Diffraction.

light source B, and a straight-edged obstacle C and an eyepiece lens D to focus and magnify the fringes. The explanation of the phenomenon is as follows. Imagine a plane wave front AB (Fig. 66) of which every point is giving out its secondary wavelet in the manner previously described. The effect of these secondary wavelets at a point such as P on the receiving

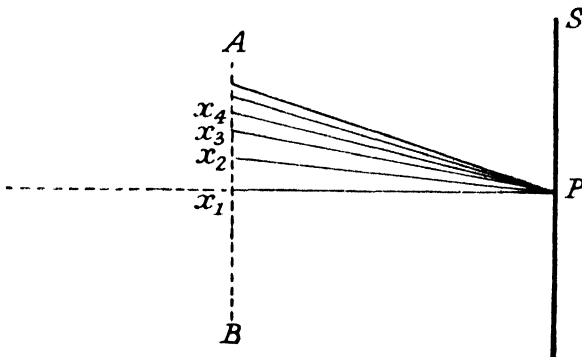

FIG. 66.—Explanation of Diffraction.

screen S is to be determined. The secondary waves from points such as x_1 , x_2 , x_3 , x_4 , etc., will have different distances to travel after leaving AB and before reaching P, and it is clearly possible to choose the positions of these points so that x_2P is greater than x_1P by half a wavelength, x_3P is greater than x_2P by half a wavelength and so on. Then the light reaching P from x_2 will be exactly out of phase with that from x_1 and will tend to neutralise it.

It can be shown that the quantities of light reaching P from the successive zones x_1x_2 , x_2x_3 , x_3x_4 , etc., chosen in this way will be equal if each secondary wavelet is equally intense in all directions. If this were the case, the light from one zone would completely cancel the light from a neighbouring zone, with the result that the brightness at P would be zero if an even number of zones were sending light to P, and a maximum if the number were odd. Accordingly there should be an infinite number of fringes on the screen of Fig. 64, because points receiving light from an even number of zones would alternate with points receiving light from an odd number all over the screen. The reason that this result is not observed is that the secondary wavelets are not equally

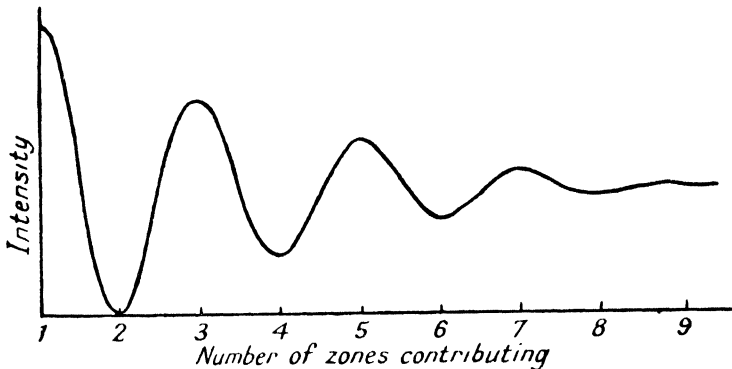

FIG. 67.—Formation of Fringes by Diffraction.

intense in all directions, but are strongest in the direction in which the primary beam was travelling, and less intense in directions inclined to it. In consequence of this, the zones further from x_1 have less effect at P than the zones near x_1 . Thus if the light reaching P comes from a small number of these zones (called half-period zones), its brightness will be controlled by the exact number of zones concerned. This variation is roughly sketched in Fig. 67. In order to investigate the effect at any point, it is necessary to determine which zones contribute to the light at that point. The light reaching a point such as P_1 (Fig. 68) is the combined effect of the complete upper half of the field (*i.e.*, AB) and of the number of half-period zones present in the length AC. If this is odd,

the brightness at P_1 is a maximum and if it is even it is a minimum. Thus the brightness alternates if P_1 moves, and a series of fringes is formed. Light reaches points such as P_2 (Fig. 64), however, only from the outer or less effective zones, and as their contribution gets progressively less, there are no

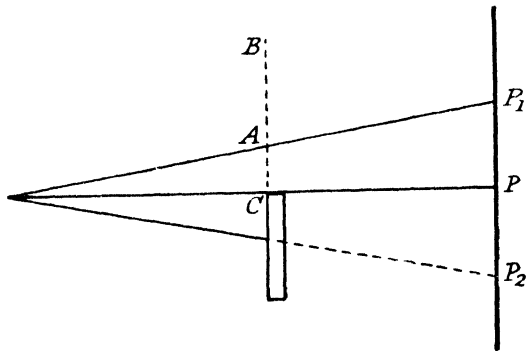

FIG. 68.—Explanation of Diffraction Fringes.

fringes below P , but simply a gradual reduction of intensity. It should be pointed out that the shape of the edge (*i.e.*, whether sharp or blunt) has no influence whatever on the spacing or brightness of the fringes, and the case discussed above has little practical value.

Narrow Slit and Thin Wire

Two slightly more complicated cases, however, are of considerable use; they are the appearance of the light passing through a narrow slit and of the shadow of a narrow obstacle respectively.

In the case of the light passing through a narrow slit, reasoning similar to the above can be applied. The intensity at any point depends on the number of half-period zones for the point that are present in the light which reaches it. The intensity at the point P_1 (Fig. 69) depends on the number of half-period zones of the slit A and on the angle between the original ray R and the line AP_1 (the greater this angle becomes, the less the intensity at P_1). Since the widths of the half-period zones depend on this angle, it follows that as P_1 moves, the number of half-period zones will alternate between odd and even and consequently the brightness at P_1 will alternate

between maxima and minima right across the central part of the field. The width of the slit controls the spacing of the fringes because if the slit is narrow, a greater movement of P_1 will be required to change the number of zones present by one than if the slit is large. The number of fringes observable

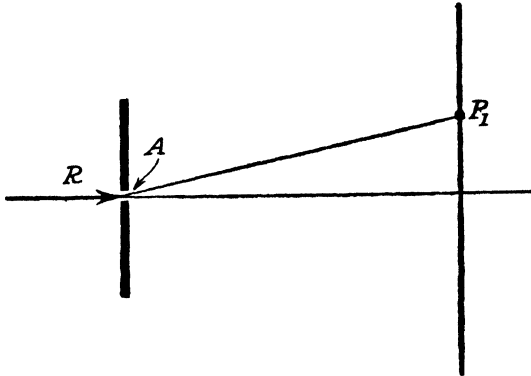
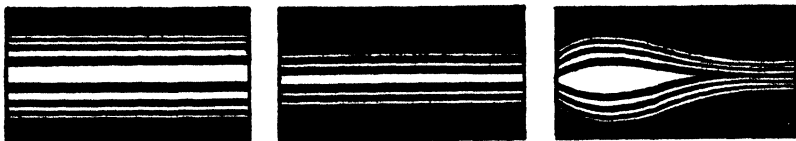

FIG. 69.—Diffraction at a Slit.

depends on the brightness of the light and the sensitivity of the observer's eye, and so is not of much utility. The diagrams of Fig. 70 show the differences between the fringes formed (a) with a narrow slit, (b) with a wider slit, and (c) with an edge whose straightness is to be tested forming a slit with an edge known to be straight. The irregularity of the fringes greatly



(a) *Narrow slit*

(b) *Wide slit*

(c) *Irregular slit*

FIG. 70.—Diffraction Patterns of Slits (diagrammatic).

magnifies that of the edge, which is thus tested with great sensitivity.

A second application of diffraction is for the measurement of the thickness of fine wires, and in particular for the investigation of variations of thickness (compare the method described on p. 98). In this case the region of the geometrical shadow

is illuminated by the whole field except for the zones obstructed by the wire. The number of half-period zones missing controls the brightness of the shadow and since this number fluctuates between odd and even, the shadow consists of a series of fringes. As in the previous case, the fringes are farther apart when the wire is thinner.

Diffraction Grating

If instead of a single slit or a single obstruction, the "obstacle" consists of a number of equally spaced equal slits, then the conditions are those of a diffraction grating. The complete theory of the diffraction grating is rather complex (see Preston, *Theory of Light*, Macmillan), but a treatment sufficient for the present purpose is given here. A parallel beam of monochromatic light L (Fig. 71) falls on the grating

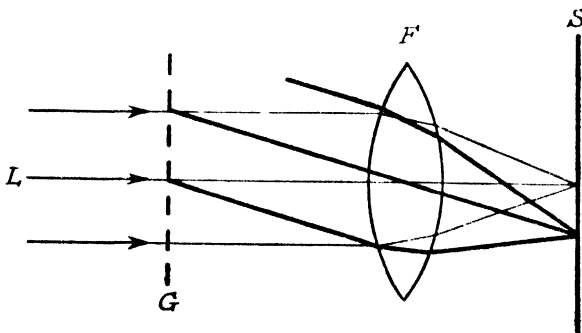

FIG. 71.—Diffraction Grating.

G , in which the centres of the slits are separated by a distance d . A lens F serves to focus all light leaving the grating in any one direction at a definite point on the screen S . One point on the screen S corresponds, therefore, to one direction of light leaving G . The light reaching S will be concentrated into a definite pattern which forms the spectrum of the light used. The condition which determines whether light will reach any given point on S is easily established. Consider two adjacent apertures of the grating (Fig. 72) and let secondary wavelets be considered to start simultaneously from their centres. In the direction AB , these wavelets will reinforce when focused on the screen if they are in phase: *i.e.*, if CD has travelled a whole number of wavelengths more than

AB (zero counting as a whole number). This excess distance is equal to CE, and the condition for re-enforcement is therefore that $CE = n\lambda$, n being an integer. But $CE = d \sin \theta$, and so the condition is that $n\lambda = d \sin \theta$. If $n = 0$, then

$\theta = 0^\circ$ and the light is transmitted in the original direction. When $n = 1$, then the first order spectrum is produced and so on. Since λ is different for different colours, the value of θ that satisfies the above relation will also vary with colour, and so the diffraction grating can be used for producing the spectrum

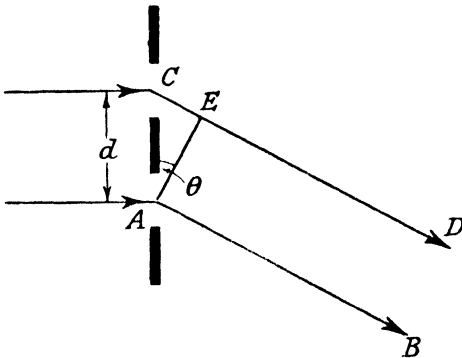

FIG. 72.—Theory of Diffraction Grating.

of light of mixed wavelengths. A diffraction grating used for optical purposes has a large number of lines to the inch; consequently d is small and θ is large.

Fine Screens

An application of this phenomenon was recently proposed by E. J. Groom and is being developed by him and the author in collaboration. The following description is taken from the article in which it first appeared.¹

A simple method of measuring the mesh of wire screens, such as those used for sifting powders, depends on the fact that such a screen can be regarded as a diffraction grating. Light falling on it is transmitted partly as a direct beam, and partly in diffracted beams making various angles with the original direction of the light. If a fine screen is held up close to the eye and a small source of light is viewed through it, a series of diffracted images can be seen. If the light is seen through a narrow slit, the diffracted images will be seen as bands parallel to the slit. If white light is used, each image appears as a spectrum, but if the light is monochromatic, each image is reduced to a narrow band. The separation of these diffracted images from the direct image depends on the spacing

¹ Chalmers, *Metal Ind.*, Lond., 1937, 50, 599.

of the wires of the screen. To apply this suppose that a source of monochromatic light S (*e.g.* a sodium lamp) is placed behind a narrow slit (Fig. 73) on each side of which extends a

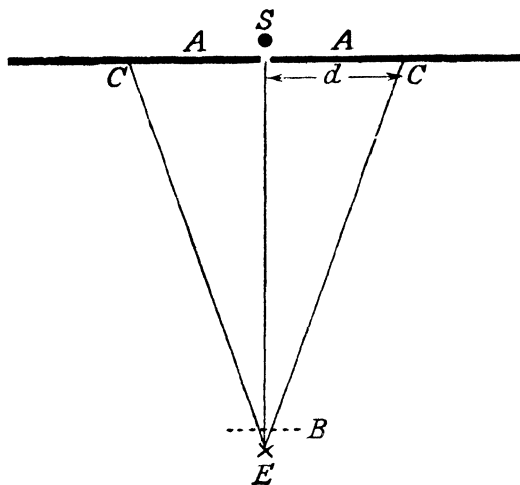

FIG. 73.—Measurement of Mesh.

scale of centimetres, AA . Let the screen be placed 1 metre away, at B , with the eye at E close to the screen. The diffracted images of S will be seen at points such as CC , at a

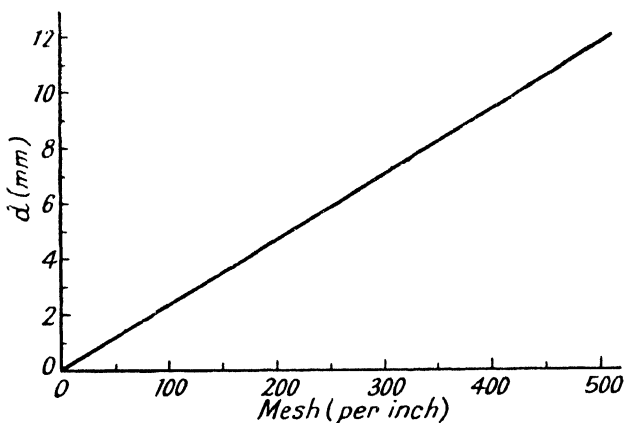

FIG. 74.—Measurement of Mesh.

distance d from S . The graph (Fig. 74) gives the calculated relation between d and the mesh of the screen in wires per inch. It will be seen that although the method is not very

accurate for coarse meshes, it improves for finer sieves, when other methods become more difficult. It is proposed to extend the method to an investigation of the variations of spacing in individual screens, and to increase its accuracy by using a spectrometer to measure the displacements of the diffracted images.

Size of Powders

Another suggested application of diffraction is for the measurement of the size and size distribution of metal powders. The method depends upon the fact, discovered by Young, that when a beam of light is intercepted by a disc, diffraction rings are formed, the diameters of the rings depending on the size of the disc. Unless the disc is small the diameters of the rings are too small to be easily measured. If a large number of small discs or particles are used simultaneously, and a

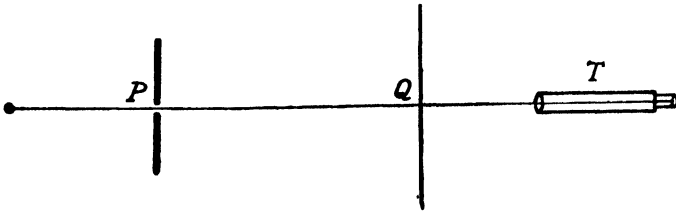

FIG. 75.—Measurement of Particle Size.

source of monochromatic light, as nearly a point as possible, is observed by means of a telescope focused on it through the space containing the discs, then the image of the source will be surrounded by a pattern of rings. The rings will be narrow and well defined if the particles are of uniform size, and for any one setting of telescope (T), pinhole (P), and particles (Q) (Fig. 75), the diameter of the smallest ring is inversely proportional to the diameter of the particles. In practice the particles can be held between two glass plates, or else a suspension in water or some other liquid can be prepared. If the liquid is such that the rate of settlement of the particles is slow, then the "sorting out" of particles on account of the variation of rate of fall with size can be used to obtain an idea of the size distribution of the particles. It is evident that this method, which is of great potential value, must be worked

out in detail before it will be of practical use. One of the possible methods of making the measurements was suggested by Young¹ as a method for measuring the size of small particles. In this method, the pinhole was surrounded by a circle of holes, and the glass plates between which the particles were held were moved backwards or forwards until the first diffraction ring coincided with the circle of holes. The distance of the specimen from the pinhole was then proportional to the diameter of the particles. If the instrument is calibrated with particles of a known size it can be used for measurements on particles of other sizes.

It will be realised from the foregoing account of diffraction phenomena that the rectilinear propagation of light only applies when the dimensions concerned are large compared with the wavelength of light. When they are not, then geometrical shadows no longer possess any precise significance, and light can no longer be regarded as travelling in perfectly straight lines. (Sound, which is also propagated by a wave motion, shows this characteristic much more obviously because of its much greater wavelength.)

Resolving Power of Microscope

The theory of the microscope, particularly in regard to resolving power, should be considered in terms of diffraction rather than of geometrical optics. Geometrically, the image of a point object should be a point, and the resolving power should be infinite; but actually the image of a point object is a series of circular fringes, whose size depends on the characteristics of the objective. The limit of resolution is reached when two point objects are so close together that their fringe systems approach too closely to be distinguished. The distribution of intensity of light in the neighbourhood of the image of a bright point is shown in Fig. 76. According to a convention suggested by Lord Rayleigh, the limit of resolution corresponds to the position when the central peak A of one image coincides with the first minimum B of the other as in Fig. 77. This case, chosen because it is readily susceptible of calculation, actually corresponds to the condition in which the minimum intensity (*i.e.*, half-way between the

¹ See Preston, *Light*, 5th edition, Macmillan, 1928, p. 257.

centres of the two images) is 0.74 of the intensity at either centre. This is not necessarily the actual limit of resolution

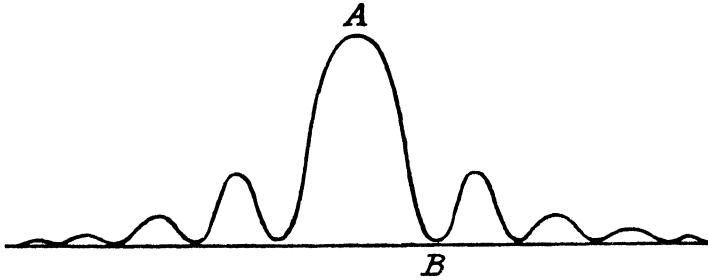

FIG. 76.—Distribution of Intensity of Light in the Image of a Point.

in all cases, because a personal factor enters owing to the difference of the minimum change of intensity detectable by different individuals. It forms, however, a convenient and reasonably correct basis for consideration, and the following treatment, based on a method due to Lord Rayleigh, will show how the resolving power depends on the numerical aperture of the lens and on the wavelength

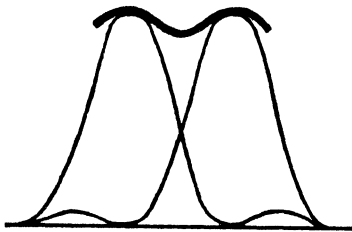

FIG. 77.—Limit of Resolution.

of the light used. Let P and P' be two point objects (Fig. 78). The rays from P which pass through the lens reach Q in phase, and Q is therefore the image of P. Rays from

P', however, do not reach Q in phase, and if the path difference between the extreme rays P'AQ and P'A'Q is equal to one wavelength, then one half of the wave will cancel

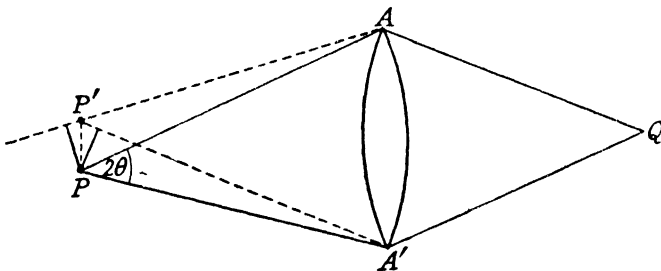

FIG. 78.—Theory of Resolving Power.

P', however, do not reach Q in phase, and if the path difference between the extreme rays P'AQ and P'A'Q is equal to one wavelength, then one half of the wave will cancel

the other half, and the intensity at Q will be a minimum. This is the first diffraction minimum referred to above. Consequently, the conventional limit of resolution is reached when $P'A' - P'A = \lambda$, λ being the wavelength of the light used in the medium occupying the space between the object and the lens.

If 2θ is the angle subtended by the lens at the object, then $P'A = PA - PP' \sin \theta$ and $P'A' = PA' + PP' \sin \theta$ (if PP' is small); hence $P'A' - P'A = 2 PP' \sin \theta$.

Thus the smallest resolvable value of PP' is given by

$$2PP' \sin \theta = \lambda, \text{ or } PP' = \frac{\lambda}{2 \sin \theta}.$$

If the wavelength in air is λ_0 , and μ is the refractive index of the medium in the object space, then $\lambda = \frac{\lambda_0}{\mu}$; and $PP' =$

$\frac{\lambda_0}{2\mu \sin \theta}$. $\mu \sin \theta$ is the numerical aperture of the lens, and is controlled by the aperture of the lens and the refractive index of the medium, if, as in an immersion lens, it is other than air. The use of highly refracting immersion oils therefore increases the numerical aperture of a lens and so increases the resolving power, which is expressed as the reciprocal of the minimum resolvable distance PP' and is accordingly $\frac{2\mu \sin \theta}{\lambda}$.

The foregoing treatment is not complete because it assumes that the two diffraction patterns formed at Q can be superposed without modifying each other. This, however, is not the case unless the two points P and P' act as independent sources of light. That is, they must be illuminated so that there is no permanent phase relation between the light reaching them. The same part of the source of light must not illuminate both points concerned, and this can only be avoided by using a condenser system which throws an image of a point of the source of light on to each point of the image. If this is not done, and the same part of the source illuminates both points, then the two images cannot be considered separately and added together, and the resulting distribution of brightness is given in Fig. 79. In this case there is no resolution of the points although the Rayleigh condition is satisfied.

It should be pointed out that the sizes of very small objects may be considerably exaggerated because an object (*i.e.*, a bright line or disc) will never appear smaller than the diffraction pattern of a point, and objects are still visible for this reason even when they are much smaller than the limit of resolution. The smallest resolvable distance therefore does not represent the smallest observable size of object.

The eyepiece magnification must be such that the eye's

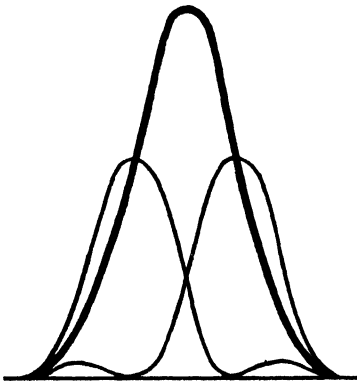

FIG. 79.—Case in which Rayleigh Convention does not apply.

limit of resolution is rather greater than that of the objective, that is, so that details of the object that are just separated in the image are easily separated by the eye. The eye cannot distinguish details that subtend an angle of less than 1 or 2 minutes of arc, and it follows that two points that can just be resolved by the objective should be magnified to subtend an angle of about 4 minutes of arc at the eye. For example, consider a lens of numerical aperture = 1, and light

of wavelength 6×10^{-5} (yellow light). The limit of resolution of two objects is given by the relation

$$PP' = \frac{\lambda}{2 \times \text{NA}} = \frac{6 \times 10^{-5}}{2} = 3 \times 10^{-5} \text{ cm.}$$

A length of 3×10^{-5} must therefore be magnified so that its image subtends an angle of $4'$ at the eye when placed at a distance of 25 cm. (assumed to be the least distance of distinct vision). Let the magnification be M , then

$$\begin{aligned} 3 \times 10^{-5} \times M &= 25 \tan 4' \\ \therefore M &= 25 \times \tan 4' \times 10^5 \\ &= 3,000 \text{ approx.} \end{aligned}$$

Thus, under the conditions specified, the total magnification should not exceed 3,000, or spurious diffraction patterns may be mistaken for real detail. In practice, the greatest numerical

aperture available is about 1.4 when ordinary photomicrography is contemplated, and the practical limit of resolution is about 140,000 lines to the inch. The centres of the lines are separated by about 1.9×10^{-5} cm. or about one-third of the wavelength of yellow light. This corresponds closely to the theoretical limit calculated above. If white light or light consisting of more than a small part of the spectrum is being used, the objective must be corrected for colour so that the different rays are in focus together. This consideration limits the numerical aperture available on account of the difficulty of designing an objective that combines all the corrections necessary for high definition with a larger numerical aperture.

If, however, the light used is confined to a single wavelength, a greater numerical aperture becomes available, and Wrighton¹ has realised the conditions necessary for resolving 180,000 lines per inch by using light of wavelength 4395 Å, with a specially computed objective with a N.A. of 1.60. This improvement is the result of using a shorter wavelength of light as well as the increased numerical aperture.

Ultra-Violet Microscopy

The benefit to be gained from using shorter wavelengths need not stop at the limit of the visible spectrum, but can be extended into the ultra-violet region where the wavelength is even shorter than at the violet end of the visible spectrum. The most important application of this principle to metallography is that described by Smiles and Wrighton.² The difficulties involved in utilising the higher resolving power that results from the use of ultra-violet light are chiefly due to the difficulty of focusing, and this has been overcome in two ways. The first is to replace the focusing screen by a screen that fluoresces when ultra-violet light falls on it. This is not very satisfactory owing to the low intensity of light usually available. The other method is to carry out the focusing by visible light, using an objective designed for the purpose, and then substituting the ultra-violet objective. This demands a device by means of which the second objective can be placed exactly in the position previously occupied by the first. Such

¹ Wrighton, *J. R. micr. Soc.*, 1933, 53, 328.

² Smiles and Wrighton, *Proc. roy. Soc.*, 1937, 158, 671.

an arrangement was constructed by Barnard and Welch.¹ The design and manipulation of the apparatus for this type of work involves several considerations that do not enter into ordinary photomicrography, the chief of which is the fact that glass is rather opaque to the shorter wavelengths such as are used in this method. Consequently, the optical parts have to be made of quartz, and this necessitates the use of a large number of components for objectives of high power. Unless special care is taken in the design of these objectives, a great deal of back reflection is liable to occur, and the general illumination due to this may so mask the details of the photograph as to counteract the advantage of the extra resolving power. Even when the lens design is good from this point of view, it is necessary to exercise great care to avoid the presence of a larger beam of light in the vertical illuminator than is necessary to utilise the full aperture of the objective. Smiles and Wrighton used a quartz objective of seven components, with a numerical aperture of 1.24, and their source of ultra-violet light was a condensed spark between cadmium electrodes. By means of a prism (also of quartz) the U.V. of wavelength 2750 A.U. was separated from the rest of the light. The equivalent aperture of this arrangement is 24 per cent. higher than that of the 1.60 lens with the wavelength 4395 A. mentioned above, and the resolving power is sufficient to resolve 200,000 lines to the inch. It must be realised that this technique, which is still in the early stages of development, requires a very high order of experimental skill as well as special apparatus, and since the gain in resolving power, while real, is comparatively small, its applications to the study of metals is likely to be very limited for some time.

¹ Barnard and Welch, *Practical Photo-Micrography*, Arnold, 3rd edition, 1936, p. 309.

CHAPTER 5

POLARISED LIGHT

It has been mentioned previously that light is regarded as an electromagnetic wave motion in the æther. It is necessary to consider this in rather more detail in order to discuss adequately the properties of polarised light. When a wave moves over the surface of water, to consider the most familiar example of wave motion, each particle of water in and near the surface moves rhythmically up and down as the wave moves horizontally. This constitutes a transverse wave motion. When light travels through the æther, an electromagnetic displacement occurs, electric and magnetic states of strain being set up in definite directions transverse to the direction in which the wave travels. Since such a wave is not confined to a surface (as is the case with a wave on water) there are any number of possible directions of displacement each of which is perpendicular to the direction of travel (*e.g.*, if the wave is moving vertically downwards, any horizontal direction is perpendicular to it). Neglecting the magnetic disturbance, the electric displacement must take place in a definite direction, and thus occupies a definite plane which determines the plane of polarisation of the light.

By way of analogy, consider a long rope stretched fairly tightly and shaken at one end. The vibration travels along the rope as a wave, and it is evident that the vibration can be in any plane which contains the rope. If the rope passes through a small hole in a rigid board, the vibrations are prevented from passing, but if the hole is replaced by a slit, then vibrations whose plane is parallel to that of the slit can pass through.

In the case of light, the natural crystal tourmaline and

the artificially prepared "polaroid" share the property of transmitting light vibrating in one particular plane only. Such light is said to be plane polarised. Ordinary light, regarded as unpolarised, consists in fact of a mixture of waves polarised in different directions. If such light falls on a tourmaline or polaroid screen, it is partially transmitted, and the transmitted part is polarised in the plane corresponding to the polarising plane of the screen. If this light is then allowed to fall on a second similar screen it will be transmitted if the planes of polarisation of the two screens are the same, *i.e.*, if the screens are "parallel." If the second screen is then rotated through a right angle, it will completely absorb the light; the screens are then said to be "crossed."

If polarised light is passed through certain materials, called "optically active," the plane of polarisation is rotated in proportion to the amount of the material through which the light passes and to a characteristic of the material. Examples of such materials are quartz and sugar. A further property of importance from the present point of view is that if unpolarised light is reflected from a smooth surface it is partially or completely polarised by reflection. The plane of polarisation is the plane containing the ray and the normal to the surface. According to the theory of Fresnel, this corresponds to electric vibrations in a direction perpendicular to this, *i.e.*, parallel to the reflecting surface and perpendicular to the ray.

A number of crystalline substances have the property of double refraction, by which a ray of light falling on such a crystal is refracted as two rays, the ordinary and the extraordinary rays. These rays are both polarised, in planes at right angles to each other, and the phenomenon is due to the fact that the velocity with which the light travels through the crystal depends on its plane of polarisation. According to the wave theory, refraction takes place when light passes from one medium into another in which it travels with a different velocity, the refractive index being equal to the ratio of the velocities. Consider the wave front BD of the beam of light bounded by the rays AB and CD (Fig.

80) approaching the surface PQ which separates two media M and N. When the ray AB reaches the surface at B, the ray CD will have arrived at D. B will then send out a secondary wavelet as shown in the diagram, and by the time D reaches D', the secondary wavelet will have a radius equal to the distance DD' multiplied by the ratio of the velocities in the two media. The wave front, formed by a series of secondary wavelets starting when successive points of BD reach PQ, will be represented by the line D'B' and the rays will proceed along the lines B'E and D'F. This change of direction (*i.e.*, from AB to BE) is the process of

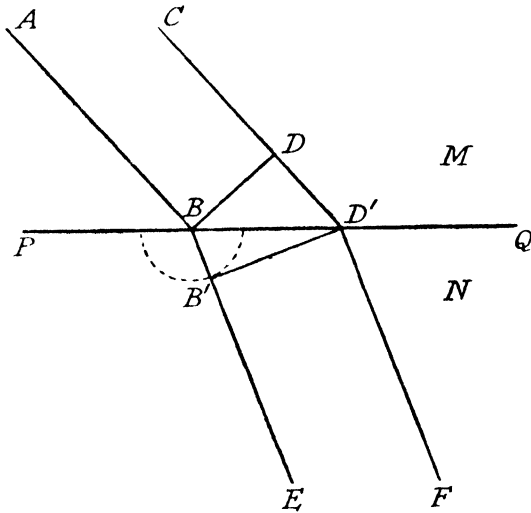

FIG. 80.—Refraction of Light.

refraction. The refractive index, defined as the ratio of the sines of the angles of incidence and refraction, is $\sin \text{DBD}' / \sin \text{BD}'\text{B}' = \frac{\text{DD}' / \text{BD}'}{\text{BB}' / \text{BD}'} = \frac{\text{DD}'}{\text{BB}'}$, and this is the ratio of the velocities in the two media. In a doubly refracting material, the velocity of a ray is different according to whether it is polarised parallel or perpendicular to the plane containing the ray and the optic axis of the crystal. For the ordinary ray, the secondary wavelet is a spherical surface, and the ray consequently obeys the ordinary law of refraction discussed above. The extraordinary ray, however, is

propagated by secondary wavelets that are ellipsoidal in form, and so the law of refraction of such a ray is much more complicated than for the ordinary ray.

Until recently, polarised light was usually produced by passing light through a Nicol prism, which consists of two blocks of a doubly refracting material such as Iceland spar, so arranged that one of the two polarised rays is separated from the other by total reflection at the boundary of the two blocks (Fig. 81). The ray AB is divided by double

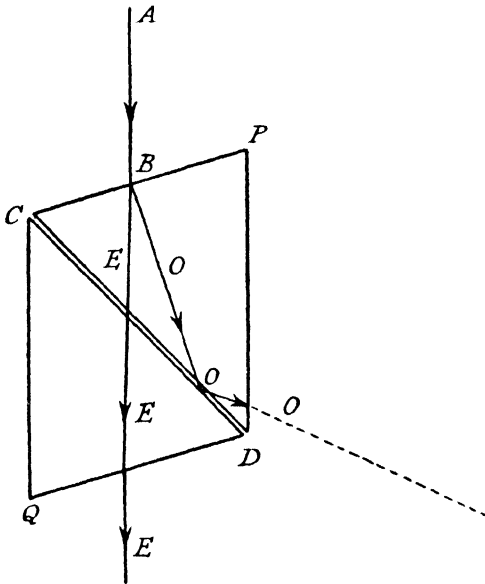

FIG. 81.—Nicol Prism.

refraction into the rays O and E, of which O is reflected at the interface CD of the two prisms CPD and CQD. The ray E, making a larger angle of incidence with the interface (which is cemented with Canada balsam) is transmitted, while the ray O is totally reflected. The ray E is then plane polarised.

This method of producing and examining polarised light has the disadvantage that large crystals of Iceland spar are very expensive, and so the effective aperture of the prism (CP) is usually small. This limits the quantity of light

transmitted, thereby reducing the sensitivity with which small relative changes of illumination can be detected.

A method introduced recently for polarising a beam of light is to use "polaroid" in which the polarising medium is a layer of crystals all oriented similarly. The substance used has the property, like tourmaline, of doubly refracting light and absorbing one of the rays, transmitting the other. Polaroid can be obtained in quite large sheets, and its use greatly increases the scope of polarised light in metallographical investigations.

Detection of Polarised Light

The detection of polarised light is also carried out by means of a Nicol prism or a polaroid screen. Plane polarised light is completely extinguished by such an analyser in two positions if the analyser is rotated through a complete circle. These are the positions in which the polariser and analyser are "crossed." At intermediate positions the transmission is at a maximum when the analyser is at right angles to the "crossed" position, *i.e.*, in the parallel position, and varies continuously between the maximum and zero. The determination of the plane of polarisation of a beam of light that has undergone some process is, as will be seen later, an important part of the process of the investigation of surfaces by polarised light. In general terms, it should be possible to make this determination by finding the setting of the analyser at which the light transmitted is either a maximum or a minimum. The accuracy with which this can be done depends on the sensitivity of the eye to small changes of brightness and since the eye can detect a much smaller absolute change if the total brightness is low than if it is high, determinations are always made at the minimum rather than the maximum position, *i.e.*, at the "crossed" position. The accuracy with which the eye can detect the position of minimum brightness is limited by the fact that the rate of change of brightness with position of the analyser is small in the neighbourhood of the minimum, and consequently it is usual to adopt an arrangement in conjunction with the analyser that slightly rotates the plane of polarisation of one part

of the visible field with respect to the rest. This arrangement, of which there are several forms, is called a half-shade, and it may either divide the field into two or three parts. Let the visible field be represented by the circle in Fig. 82 and let the arrows in the left-hand side of the field indicate the plane of polarisation of the light reaching it. By means of a suitable thickness of quartz or other optically active material, let the right-hand half have its plane rotated to the position indicated. If this is viewed through an analyser, the two sides of the field cannot be extinguished at the same setting of the analyser, but if the analyser is set so that its plane of polarisation bisects the angle between the directions in the two parts of the field, they will appear

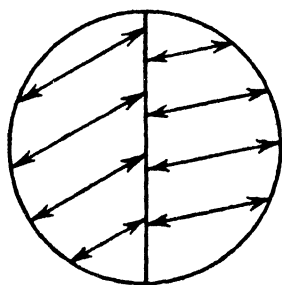

FIG. 82.—Half-shade.

FIG. 83.—Half-shade,
Triple Field.

FIG. 84.—Biplate.

equally bright. A slight rotation of the analyser either way will make one part brighter and the other darker, and this allows the analyser to be set with great accuracy. If, owing to incorrect adjustment of the optical system, the field is not equally bright all over, uncertainty or inaccuracy may occur in the setting of such an analyser. This can be avoided by dividing the field into three parts (Fig. 83). If conditions are adjusted so that both the outer sections match the centre section, then the setting is correct.

A device that is often used where very sensitive settings are required is the "biquartz," in which the biplate (Fig. 84) consists of two semicircular plates of quartz, one rotating the plane of polarisation to the right and the other rotating it to the left. The thickness (3.75 mm.) is chosen so that yellow light has its plane of polarisation rotated by 90° .

Light of this colour will be quenched by the analyser if the latter is placed with its plane of polarisation at right angles to the position in which it would extinguish the ray if the biquartz were absent. The plane of polarisation of the yellow light is rotated through a right angle, in opposite directions in the two parts of the field, and it is therefore all polarised in the same plane. But the other colours are rotated differently and so a setting that extinguishes yellow will transmit a colour complementary to yellow (red-violet). If the setting is correct, the two halves of the field are the same colour ; but if the setting is slightly out, red will be

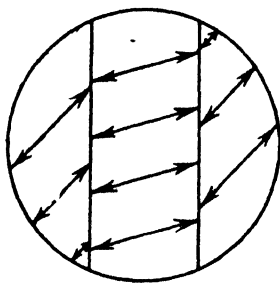
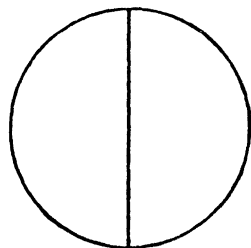
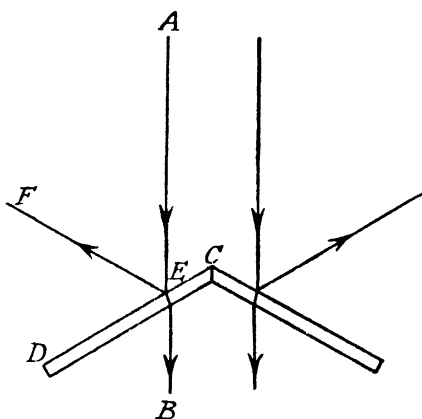

FIG. 85.—Biplate (Kent).

extinguished on one side and blue on the other, causing a difference of colour to which the eye is very sensitive.

An arrangement that has been used in experiments on metals, and has the advantage that it is inexpensive and easily constructed, was devised by Kent.¹ Two glass slips (Fig. 85) made of strain-free microscope slides, are mounted so that their planes are at an angle of about 120° . They are mounted to rotate with the analyser, the common edge being in or perpendicular to the plane of polarisation of the analyser. The angle between the common edge and the direction of the beam of light is adjustable, and the two plates make equal angles with the direction of the beam of light. A short focus telescope is focused on the common

¹ Kent, *Phys. Rev.*, 1919, 14, 459.

edge through the analyser, and the setting is made by getting the brightness equal on both sides of the common edge. Owing to the intrusion of multiple reflections, the observation must be taken close to the central dividing line. The dividing line is made more distinct by bevelling the abutting edges to 60° as shown in Fig. 81.

The theory of this instrument is that a plane polarised ray AB can be resolved into two components, polarised in and perpendicular to its plane of incidence with the glass plate CD. The light reflected along EF consists largely of one of these components, and so the transmitted part which reaches B has the ratio of these two components changed. This causes a rotation of the plane of polarisation of AB, the two components recombining to give a ray which is still plane polarised but in a different plane. The amount of this rotation depends on the angle that the plane of incidence makes with the plane of polarisation of the incident ray, and that depends on the angle at which the common edge is set. The light on the other side of the common edge is treated in the same way, its plane of polarisation being rotated in the opposite direction. If the plane of polarisation of the incident light is parallel to the common edge, the two rotations will be equal, and the two halves will appear equally bright. Any slight inaccuracy in the setting of the analyser will cause one half of the field to be darker and the other brighter as in the half-shade method described above.

Elliptically Polarised Light

If a beam of plane polarised light is passed through a doubly

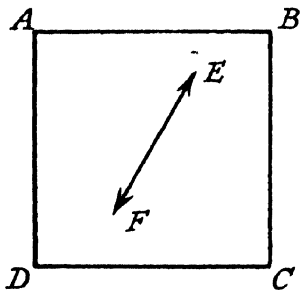

FIG. 86.—
Double Refraction.

refracting material, it may become circularly or elliptically polarised. Consider a plate of a doubly refracting material, the top of which is represented by the square ABCD (Fig. 86). Let this be cut so that light polarised in the direction AB forms the ordinary ray, and light polarised perpendicularly to this, the extraordinary ray. If light polarised in either

of these directions falls on the plate, it is transmitted unchanged, but light polarised in some other direction, *e.g.*, EF, is split up into two components, the ordinary and the extraordinary rays. The intensities of the two components depend on the angle between the line EF and the direction AB and each is equal to the intensity of EF multiplied by the cosine of the angle between EF and AB or BC as the case may be. These two components are transmitted with different speeds, and so the thickness of the plate contains a different number of the wavelengths of the two rays. Consequently, the two rays may not be in phase when they emerge from the plate. In that case they will combine together as circularly or elliptically polarised light. The conception of the polarisation being circular or elliptical derives from the fact that if a particle has two simultaneous vibrations of equal frequency in directions at right angles to each other, the particle will in general move in an ellipse, and in particular cases in a circle or a straight line. This may be realised more clearly if the process is reversed and circular motion is resolved into two linear motions at right angles to each other (Fig. 87).

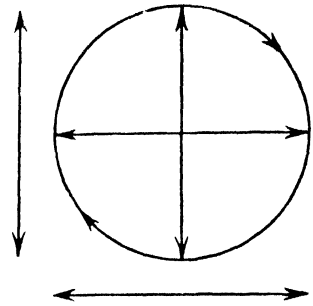

FIG. 87.—Circular Motion as the Resultant of two Linear Motions.

It will be seen that these motions are equal in amplitude and 90° out of phase (*i.e.*, one must be at its extreme position while the other is passing through the centre of its vibration). If circular motion is regarded as the resultant of two such linear vibrations, it can take place in either direction, according to the relative phases of the two linear movements. If the two linear vibrations are not equal in amplitude and exactly 90° out of phase with each other, the motion will be elliptical instead of circular. Any elliptical motion can, however, be resolved into two linear vibrations at right angles to each other having a phase difference of 90° , the amplitudes of the two vibrations not in general being equal. In Fig. 88, the elliptical motion represented is the result of the two linear vibrations

AB and CD which are about 60° out of phase and of unequal amplitudes. The ellipse can, however, be resolved into the components PQ and RS which form the major and minor axes of the ellipse, and are 90° out of phase. In a similar way it follows that any elliptical motion can be converted

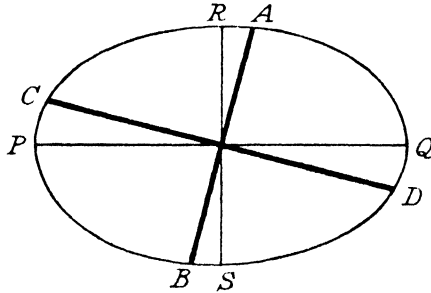

FIG. 88.—Elliptical Motion.

to a linear motion by resolving it into any two linear vibrations, suitably altering the phase of one of these components so that it is in phase with the other, and then recombining them. The importance of these considerations will be apparent when the analysis of elliptically polarised light is discussed.

Analysis of Elliptically Polarised Light

If plane-polarised light is split by double refraction into two components of equal amplitude by setting the plane of polarisation at 45° to the lines AB and BC of Fig. 86, then circularly polarised light is produced if the light passes through such a thickness of doubly refracting material that one component is retarded by an amount equal to a quarter of a wavelength with respect to the other. A plate of this thickness is called a quarter-wave plate. When elliptically polarised light is passed through a quarter-wave plate, it becomes plane polarised if the directions AB and BC of the quarter-wave plate coincide with the axes of the ellipse of polarisation. The analysis of elliptically polarised light, which is often produced when plane-polarised light is reflected by a metal surface, consists in the determination of the phase difference and the ratio of the intensities of the two components. This is done most satisfactorily by means of the Babinet compensator, the principle of which is as

follows: the compensator consists of two wedges of quartz ABC and DEF (Fig. 89) cut so that the optic axis of ABC is in the plane of the page and parallel to AB, and that of DEF, perpendicular to the page. A ray of light R reaching the surface AB is transmitted as two rays, the ordinary and the extraordinary, travelling at different speeds. The planes of polarisation of the two rays are parallel and perpendicular to the plane of the paper respectively. When the two rays pass from the first wedge into the second, they interchange their velocities, the ordinary ray for the first wedge becoming the extraordinary ray for the second. The phase difference introduced by the passage through the compensator depends therefore on the difference between the thicknesses

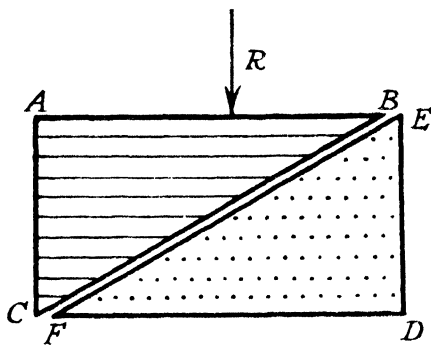

FIG. 89.—Babinet Compensator.

of the two wedges through which the light passes. This changes from one end to the other, being zero at the centre, where the two wedges are equally thick.

If plane-polarised light falls on the wedge, it emerges as plane-polarised light at the centre and at a series of other points where the phase difference introduced is 180° , 360° , 540° , etc. The plane of polarisation is parallel to the original direction where the phase change is 0° , 360° , 720° , etc., and the light can be extinguished by an analyser set as it would be to extinguish the light before it enters the compensator. If the compensator were viewed in this way, the light passing through it would show a variety of colours with a dark band at the centre (this serves to identify the centre). If monochromatic light were used, the field would be crossed

by a series of dark bands. Since, as was pointed out above, any elliptically polarised light can be transformed into plane-polarised light by giving one of its components a suitable phase change, any elliptically polarised light will pass through the compensator as plane polarised light at certain points where the phase change has the appropriate value. When elliptically polarised light passes through the compensator, the dark bands formed as described above will be moved from the position they occupy for plane-polarised light by an amount proportional to the phase change required. This quantity is easily measured by means of a screw which either moves a cross wire across the field or else moves one of the wedges transversely. The details vary with different methods of mounting of the compensator, but in general the ratio of the phase change to 360° is equal to the ratio of the movement required to bring the central dark band to the zero

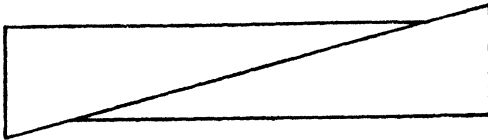

FIG. 90.—Soleil-Babinet Compensator.

position to that required to cause one dark band to replace the next. The positions of the axes of the ellipse of polarisation can be determined by setting the cross wire at a position corresponding to a phase change of 90° , and turning the compensator until a dark band is obtained on the cross wire. The principal planes of the compensator (*i.e.*, the plane of the paper (Fig. 89) and the plane perpendicular to it) are now coincident with the axes of the ellipse. The ratio of the axes of the ellipse is equal to the tangent of the angle between the polarising plane of the analyser and a principal plane of the compensator.

An instrument that has been used considerably in investigations of this type is that originated by Soleil, the Soleil-Babinet Compensator. This consists of two quartz wedges, both cut the same way with respect to the optic axis, and so mounted that the amount of overlap can be adjusted and measured (Fig. 90). This allows any desired thickness of

quartz to be introduced, and any required retardation can thereby be introduced in order to convert the elliptically polarised light to plane-polarised light. The thickness of quartz required gives a measure of the relative retardation or phase difference of the two components, and the azimuth or plane of polarisation of the restored plane polarised light gives the ratio of the intensities of the two components into which the elliptically polarised light is resolved by the compensator. In order that this method may be applied with high accuracy, it is necessary to use a sensitive method for determining whether light is plane polarised or not. For this purpose Tronstad¹ devised an improved form of "ellipticity half shade," in which the two halves of a field can only be made equally bright when the light is plane polarised.

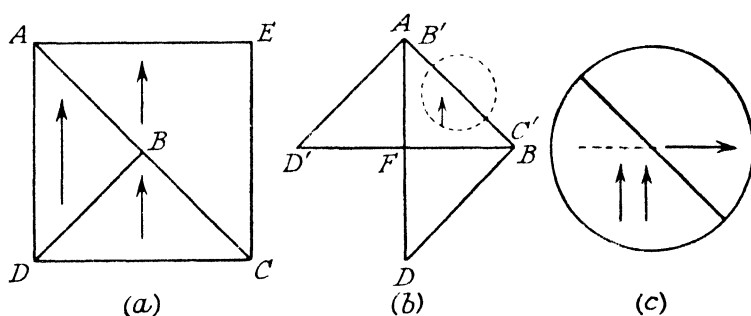

FIG. 91.—Construction of Ellipticity Half-shade (Tronstad).

The ellipticity half-shade can be constructed as follows : a sheet of mica having a retardation of about 20° is prepared by cleavage and is cut as shown in Fig. 91 (a), the azimuth of fast transmission being shown by arrows. The two pieces ABD and BCD are superposed as in Fig. 91 (b), so that the part ABF has a retardation of 40° . A semicircle cut from this section is fixed between glass discs. A piece from AEC is superposed so that its fast direction is perpendicular to that of the other (Fig. 91 (c)) ; the result is that the semicircles have opposite, equal retardations of 20° . Elliptically polarised light will necessarily be made more elliptic by one half and less elliptic by the other, and so would not appear

¹ Tronstad, *J. sci. Instrum.*, 1934, 11, 144.

equal in the two halves when viewed through an analyser, except in certain positions of the analyser. Plane polarised light, however, will remain plane polarised if its plane of polarisation is parallel to the "fast direction" of either half of the field; it will therefore be extinguished equally in both halves of the field at any position of the analyser.

For less accurate observations the quarter-wave plate can be used for determining the constants of elliptically polarised light. If the quarter-wave plate is set so that it converts the light to plane-polarised light (as judged by an analyser) its axes of fast and slow transmission coincide with the major and minor axes of the ellipse. The tangent of the angle between the plane of polarisation of the analyser and one of the axes of the quarter-wave plate is the ratio of the axes of the ellipse.

Applications

The applications of polarised light in metallurgical investigations can be regarded as coming under two headings. The physical and chemical state of a surface, and particularly of a metal surface, can be studied by an examination of the characteristics of polarised light reflected from such a surface; this may be termed the macroscopic type because the surface as a whole is examined quantitatively. Secondly, differences between different parts of the same surface can often be detected, and the nature of the various phases sometimes determined, by microscopic examination using polarised light.

Drude's Method : General Theory

The macroscopic method, originated by Drude,¹ depends upon the fact that the refractive index and the absorption coefficient of the material of a metallic surface can be measured by means of polarised light, and that these are altered by any process that modifies the surface.

The theory of metallic reflection, on which this method is based, was formulated by Drude (see Drude, *Physical Optics*), and the following general discussion, while by no means adequate theoretically, is sufficient to enable the method to be applied in practice. A ray of plane polarised light makes

¹ Drude, *Wied. Ann.*, 1889, **36**, 532; 1890, **39**, 481.

an angle of incidence θ with a polished metal surface. The plane of polarisation is at 45° to the plane of incidence (*i.e.*, to the plane containing the incident ray and the normal to the surface). The ray is considered to be resolved into two equal components, each plane polarised, one in the plane of polarisation and the other perpendicular to it. These two rays are reflected at the surface by processes which, in detail, are somewhat different, the depths of penetration and the times taken being unequal. This is due to the fact that for one of the rays the electrical vibration is taking place parallel to the metal surface and for the other in a plane perpendicular to it. Each ray therefore suffers a reduction in intensity and a phase retardation. Consequently the two rays are in general, after reflection, unequal in intensity (their ratio being represented by $\tan \psi$) and a phase difference (Δ) exists between them. These two quantities correspond to the characteristics of the elliptically polarised light that results from the reflection. The fundamental physical properties of the material forming the surface, the coefficient of absorption K and the refractive index n can be calculated by the methods described below from data obtained by measurements of the characteristics of the reflected light.

We will now consider in detail the methods used and the results obtained in some of the more important investigations carried out by this method.

Tronstad's Experiments

The first experiments by this method which need be considered here were carried out by Tronstad,¹ whose experimental method was briefly as follows :

White light from a source S (Fig. 92) was focused on the slit B of an instrument similar to a spectrometer, parallel light being produced by the lens L and directed through a polariser P and quarter-wave plate Q on to the specimen M. The light reflected from M was passed through a half-shade H and analyser A and viewed through the telescope T_1T_2 . The specimen was contained in a cell provided with windows through which the light could pass, in order that changes of the optical characteristics could be examined

¹ Tronstad, *Trans. Faraday Soc.*, 1933, 29, 502.

during electrolysis or when the specimen was immersed in any required liquid. The adjustments, which must be made with considerable care, are as follows: the polariser is set at 45° to the plane of incidence by first adjusting it so that the light reflected is plane polarised (it must then be polarised in or perpendicular to the plane of incidence) by removing the quarter-wave plate and examining the reflected light with the ellipticity half-shade. The polariser is then turned through

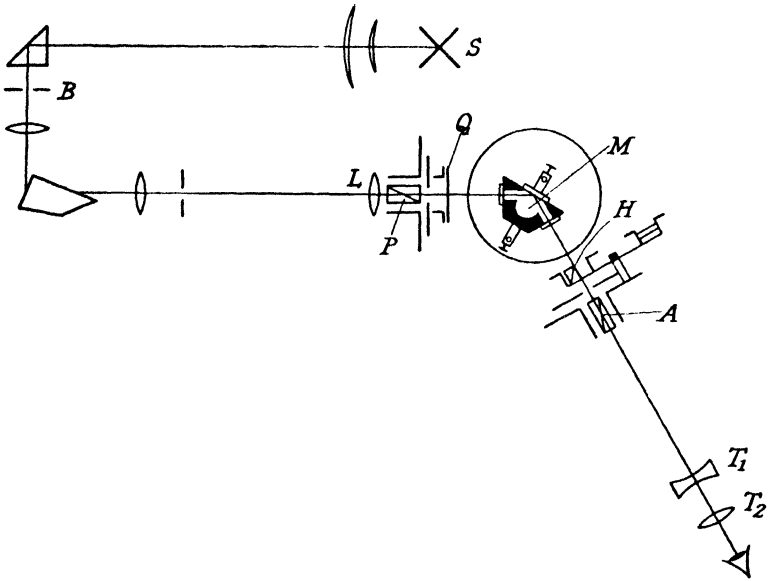

FIG. 92.—Tronstad's Apparatus.

45° from the zero position found in this way. The quarter-wave plate is then replaced and is rotated so that the light reflected from the specimen is plane polarised, *i.e.*, so that the phase difference introduced by the quarter-wave plate is exactly neutralised by the reflection. Since any phase difference can be introduced by means of the quarter-wave plate according to the direction of its axis, this is always possible.

The optical constants of the surface for the particular wavelength of light used are computed from the formulae

$$\tan \psi = \frac{\tan \theta}{\tan a}$$

when θ is the angle at which the analyser would be set for

extinction if the absorptions were equal (*i.e.*, 45°) and α is the angle at which it is actually set, and

$$n = \frac{\sin \phi \tan \phi \cos 2\psi}{1 + \cos \Delta \sin 2\psi}$$

and
$$K = \sin \Delta \tan 2\psi$$

ϕ being the angle of incidence, and Δ the phase difference resulting from the reflection.

In a later modification of the apparatus¹ the polarising nicol could be turned to any azimuth P and the quarter-wave plate was fixed in the azimuth Q. As before, the incident light was adjusted, in this case by turning the polariser, until the reflected light was plane polarised. The ellipticity half-shade was used to determine when the light was plane polarised, and a half-shade was then used to determine the azimuth of the restored plane-polarised light; then

$$\begin{aligned} \sin \Delta &= (\sin 2QP \sin \delta) / \sin 2\theta \\ \tan \psi &= \tan \theta / \tan A \end{aligned}$$

where $\cos 2\theta = \cos PQ \cos 2Q + \sin 2PQ \sin 2Q \cos \delta$, and δ is the phase difference introduced by the quarter-wave plate (nominally 90°).

It will be seen that this method of experiment avoids the necessity of measuring the characteristics of elliptically polarised light, a process in which great accuracy is not easily attained owing to the fact that with either type of compensator (Babinet or Soleil-Babinet) a linear movement has to be controlled and measured to a high degree of precision, a process not susceptible of such high accuracy as the measurement of angular movements on divided circles or with optical levers. The ellipticity half-shade method, as described above, is to be regarded as a very sensitive method of detecting any departure from plane polarisation.

A further development of Tronstad's method has been described by A. B. Winterbottom,² in which a polarisation spectrometer is fitted with the same arrangement of polariser,

¹ Tronstad, *J. sci. Instrum.*, 1934, **11**, 144.

² Winterbottom, *J. sci. Instrum.*, 1937, **14**, 203.

quarter-wave plate and analyser, but apart from the rather simplified manipulation of this instrument as compared with the earlier one, there is no difference that need be considered here. It is pointed out, however, that when a cell is used in order that the specimen may be kept in a liquid, the optical properties of the glass forming the windows are important, as the double refraction displayed by glass when under stress may be sufficient completely to vitiate the results.

Using the method outlined above, Tronstad and his collaborators have investigated numerous surface properties of metals, the basic idea being that the addition of a layer, even of a transparent material, to the surface of a metal must in general have the effect of altering the refractive index or absorption factor or both. Tronstad shows theoretically¹ that this must be so, and he gives examples in the same paper of five types of investigation that can be carried out by this method, which is sensitive for investigating the formation and growth of layers of thicknesses from 10 to 50 A.U., *i.e.*, 10 to 50×10^{-8} cm. These types of investigation are respectively :—

(a) *Passivity*.—Measurements were made on the surface while it was acting as anode or cathode in various solutions. In this way the formation and growth of the surface films responsible for passivity were studied. One of a number of examples cited in the paper referred to was the treatment of iron in a solution of 0.5N. NaOH and 1N. Na₂SO₃ with a current density of 0.2 – 0.4 ma/cm.², the iron surface acting alternately as anode and cathode. The two optical properties varied in similar manner, and this variation is represented in Fig. 93.

The growth of an anodic film and its relative stability as cathode in the alkaline solution and the rapid removal of the film in acid solution, are clearly revealed in this way.

(b) *Atmospheric Oxidation*.—The experiments on passivity were carried out with the specimen enclosed in an electrolytic cell, the readings being taken without removing it from the solution or switching off the current. Experiments on the formation of the oxide film on iron in ordinary or special

¹ *Loc. cit.* p. 131.

atmospheric conditions were carried out in much the same way, and, although these experiments were not carried as far as the electrolytic ones, it was shown that the method is capable of giving very interesting results.

(c) *Adsorption of Gases on Metals*.—It was shown, by using

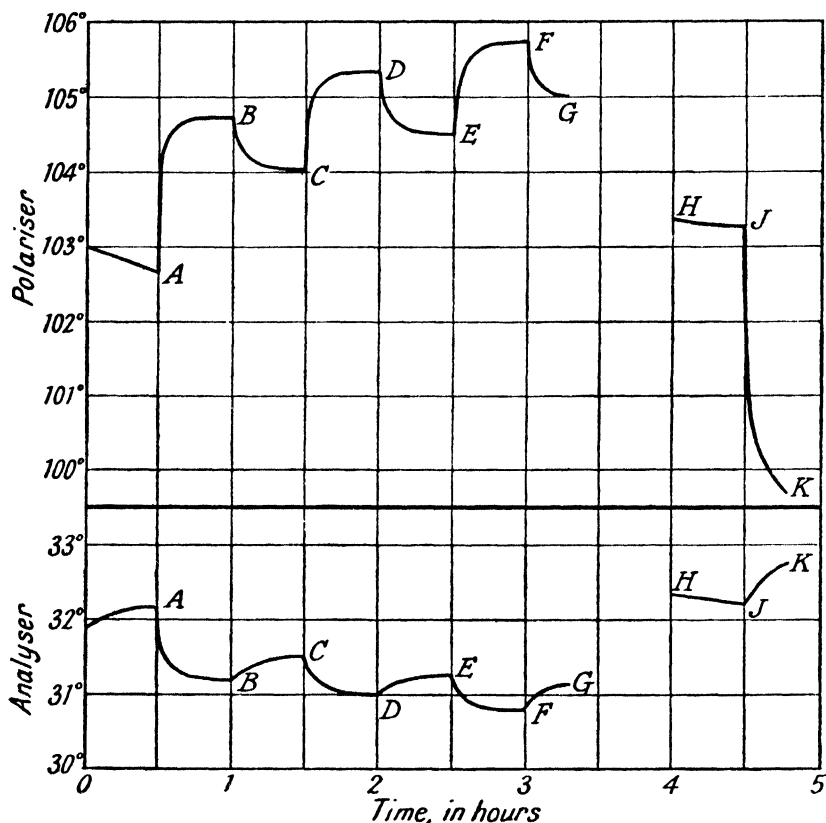

FIG. 93.—Iron in 0.5N. NaOH, 1N. Na₂SO₄. Current density under stationary conditions: 0.2–0.4 ma/cm.². From zero to A, Cathode. A to B, Anode. B to C, Cathode. C to D, Anode. D to E, Cathode. E to F, Anode. F to G, Cathode. H to J, Treatment in N. H₂SO₄. J to K, Anode in the acid solution D = 15 ma/cm.².

a cell that could be evacuated, that part of the film that forms during exposure to the atmosphere is removed by the application of a vacuum. This shows that part of the so-called oxide layer is actually an adsorbed layer of gas.

(d) *Monomolecular Films (Monofilms) on Metals*.—It was demonstrated that the formation of monofilms on metal

surfaces could be studied by examination of the surface by the polarised light method.

(e) *Surface Migration*.—It was suggested that the study of surface migration could be carried out by the same method, the technique being modified by focusing the telescope on the surface under examination instead of for parallel light. Differences between different parts of the surface would become apparent, and the movement of one phase across another could be studied. This should really be regarded as a modified example of the microscopic method which is considered below.

It should be observed that the use of polarised light allows a surface to be examined while it is being acted upon by various agencies that are under control, and that a quantitative relation can be obtained between the cause acting and the effect produced. It must not therefore be assumed that the perfection of the electron diffraction technique relegates the polarised light method to the realms of history. Since an electron diffraction study of a surface can only be made when the specimen is enclosed in a very highly evacuated space, it follows that investigations such as the five described above cannot be carried out by that method.

Further work by Tronstad and his collaborators ¹ has made use of the theoretical considerations of Drude that the thickness of a film can be computed from the effect it has on the optical properties of the underlying surface. Details are given of the methods used in the paper referred to and it is sufficient here to set out the formulæ required for calculation.

Let L = thickness of film

n_1 = refractive index of film

Δ = phase difference in absence of film

Δ = phase difference with film

ψ = azimuth of restored plane-polarised light without film

$\bar{\psi}$ = azimuth of restored plane polarised light with film

ϕ = angle of incidence

¹ Tronstad and Feacham, *Proc. roy. Soc.*, 1934, **145**, 115; Tronstad and Borgmann, *Trans. Faraday Soc.*, 1934, **30**, 349; Tronstad and Hoverstad, *ibid.*, 362.

$k = \sin \Delta \tan 2\psi =$ absorption coefficient

$\lambda =$ wavelength of light used

$$\Delta - \bar{\Delta} = -\frac{4\pi L}{\lambda} \frac{\cos \phi \sin^2 \phi}{(\cos^2 \phi - a) + a'^2} \left(1 - \frac{1}{n_1^2}\right) (\cos^2 \phi - a)$$

$$2(\psi - \bar{\psi}) = \frac{4\pi L \sin 2\psi a' \cos \phi \sin^2 \phi}{\lambda (\cos^2 \phi - a)^2 + a'^2} (1 - n_1^2 \cos^2 \phi) \left(1 - \frac{1}{n_1^2}\right)$$

where $a = \frac{1 - k^2}{n^2(1 + k^2)^2}$ and $a' = \frac{2k}{n^2(1 + k^2)^2}$

From these formulæ it will be seen that computation of L and n_1 will be a laborious undertaking. But the method is one of great potential value because it can be used for measuring films for which the interference colour method is not applicable. In the second and third papers referred to on page 136, measurements are described on the oxide films on iron and steel and on aluminium. It is confirmed that the establishment of passivity coincides with the formation of an oxide film, and the thicknesses of the oxide films formed in various circumstances are given as follows :

	A.U.
Aluminium	100
Steel in conc. HNO_3	100
Steel in alkaline solution	30
Purer iron in HNO_3	25-35
Iron and steel in chromic acid	30-40
Austenitic stainless steel in conc. HNO_3	10
Austenitic stainless steel in air	10

Measurements are also described by Tronstad and Feacham (*loc. cit.*) on films of fatty acids on mercury. This is a particularly suitable example for testing the applicability of the method because a clean mercury surface can be obtained and the thickness of monomolecular films of fatty acids can be confirmed by other methods. Although the assumptions made by Drude in his derivation of the formulæ cannot now be accepted, the results at which he arrived have been found, on theoretical as well as practical grounds, to be correct, and it is safe to conclude that the polarised light method of examining surfaces gives a true indication of the action that occurs when metal surfaces are exposed to various conditions,

the quantitative results probably approximating very closely to the truth.

Lowery's Experiments

Another series of investigations by the polarised light method has been described by Lowery and his collaborators. The object of this work was to obtain the relationship between the optical properties and the composition of a series of alloys. The difficulty of obtaining reproducible results with different specimens of the same composition led to a study of the effect of polishing technique on the absorption coefficient and refractive index. Using the "direct" method, in which plane polarised light falls on the surface and is analysed after reflection by the Babinet or Soleil-Babinet Compensator, Lowery and Moore¹ found that it was very difficult to prepare a standard surface, and they concluded that there is no way even of defining a standard of polish. The polished surface of a metal is regarded, following Beilby, as consisting of a layer of metal in an amorphous state.² The depth of this layer is believed to vary between 20 and 40 A.U. (*i.e.*, about 10 to 30 atoms), and it is also believed that a layer up to 1,000 atoms in thickness is so disturbed by the polishing process that it differs appreciably in its properties from the undisturbed metal. The depth and degree of distortion of these layers depends on the violence of the polishing process.

It has been found that the optical constants are different in the solid and liquid forms of the same metal, and it follows that the optical properties of a surface depend on the arrangement of the atoms as well as on the kind of atoms present. Thus it would be expected that the amount of distortion of the crystal lattice in and just below the polished layer should influence the optical properties. It is estimated by Lowery and Moore that when light is reflected from a copper surface, it actually penetrates to a depth of 150–200 A.U., *i.e.*, up to 100 atoms, and so it is probable that the exact characteristics of the polish layer should influence the optical constants.

¹ Lowery and Moore, *Phil. Mag.*, 1932, **13**, 138.

² This view is confirmed by most of the electron diffraction evidence, although it is held in some quarters that the layer is not truly amorphous.

The experiments of Lowery and Moore were carried out on a Fuess Spectrometer Goniometer using a Nicol prism as polariser, with its plane of polarisation at 45° to the plane of incidence, and a Jamin-Babinet compensator with a Nicol prism as analyser. The method of making the necessary adjustments is described in detail in the paper and does not present any great difficulty.

Although the results obtained do not lead to any very definite relations between the depth of polish (estimated by time of polishing and checked by time of etching) and optical constants, it is concluded that a light polish is preferable to a heavy one as it gives a greater reflecting power. The change of the constants with time if the surface is exposed to the air was also investigated and it was found that both refractive index and reflecting power change in an approximately linear manner with time. This regular variation with time permitted a correction to be applied for the effect of exposure to air when a number of readings (*e.g.*, at different wavelengths) were taken with the same specimen.

The difficulty of obtaining a standard surface on a specimen of, for example, copper, points to still greater difficulties in dealing with a series of alloys whose mechanical properties vary considerably, and which are therefore not subjected to equal degrees of surface cold working even when polished in exactly the same way. This is a difficulty which cannot be completely overcome, because there is no theoretical standard of polish to be attained by special treatment of each alloy. Lowery and his collaborators¹ refer to the possibility of polishing by the electrolytic method of Jacquet,² by which it would be quite possible to remove the surface material to a known depth, which could be controlled so as to be the same for each of the series of alloys. It is pointed out, however, that it is doubtful whether the surface remaining would have the same composition as the material in bulk owing to the possibility that the rates of removal of the two constituents would not be proportional to their quantities. The importance

¹ Lowery, Wilkinson and Smare, *Phil. Mag.*, 1936, **22**, 764; *Proc. phys. Soc.*, 1937, **49**, 345.

² Jacquet, *Trans. electrochem. Soc.*, 1936, **69**, 629.

of difficulties of this kind depends on the extent to which the mechanical properties vary among the series of alloys chosen for investigation, and Lowery and his collaborators have chosen different methods in different cases.

The first series of alloys investigated by Lowery was the copper-nickel system, which was chosen because it forms a continuous series of solid solutions ; this avoids the difficulties inherent in two phase alloys. The crystal lattice is always cubic, and the properties are therefore independent of the orientation of crystals relatively to the surface. It is known that the variations of electrical conductivity, thermal conductivity and thermoelectric power with composition are continuous and non-linear, and this system was therefore suitable for carrying out a test of the method. A particular point of interest attaching to this series of alloys is the change of colour from copper to nickel, this being a particularly obvious aspect of the variation of the optical properties, caused by the existence of an absorption band for copper in the visible spectrum.¹

The experimental work, which was carried out with considerable precision, indicated that consistent results could not be expected unless special care was taken with polishing. The flowed or worked layer was reduced to a minimum by bright annealing *in vacuo* at 750° to remove the strain introduced in grinding and polishing, and then finally polishing with magnesia until a satisfactory surface was obtained. The values of the optical constants increase as the polish improves, and so it was possible to decide, with experience, whether a polish was good or not. The authors point out that results of this sort do not mean much unless at least three independent polishes are used on each specimen. In the original paper, the three sets of readings are given for each composition, and agreement is seen to be quite good, the variation seldom exceeding 5 per cent.

The results are chiefly of interest for their indication that the method is a valid one for the investigation of the variation of a physical property of a series of alloys with composition, and curves are given showing how the refractive index and

¹ Cf. p. 21.

the absorption coefficient vary with composition for various wavelengths of light. The importance of avoiding a cored structure is emphasised, and it will be seen that this is of extreme importance because the method adopted in making the measurements depends on the assumption that the surface is homogeneous.

Lowery¹ has also investigated the optical constants of the copper-zinc system, which is also of interest on account of the colours of the various phases of the system; the typical colour of pure copper changes to the yellow of brass in the alpha phase (up to 39 per cent. by weight of zinc), the narrow beta phase, 46.5–49.6 per cent. of zinc, shows the red of copper, and from 60 to 69 per cent. zinc, the hard gamma phase shows a silvery colour.

In these experiments the difficulty of obtaining a standard polish was greater than with the copper nickel alloys because of the greater differences of mechanical properties. This difficulty was avoided by grinding and polishing all the specimens (eight in number) together, having embedded them in a lead block. While this ensures that all the specimens receive the same treatment, it does not necessarily give each the same amount of surface cold work, and is therefore open to objection on that score.

The results of such experiments are nevertheless of considerable value, and an example of this is to be found in the fact that the paper under discussion is followed by a note by Mott² on the theoretical interpretation of the results.

It should be remembered that experiments such as these are used for measuring the optical properties not of a metal but of a metal surface prepared in a particular way. The atoms constituting such a surface from the optical point of view are not arranged in the same way as in the interior of the metal, because inside the metal each atom is surrounded by neighbours occupying their correct positions on the lattice, while near the surface this arrangement is necessarily disturbed. This is a fundamental property of the surface and does not depend on how the surface is prepared. If the surface is

¹ Lowery, Wilkinson and Smare, *Proc. phys. Soc.*, 1937, **49**, 345.

² Mott, *Proc. phys. Soc.*, 1937, **49**, 354.

prepared by polishing it is covered with a layer of atoms whose arrangement is believed to be amorphous and is certainly very different from the regular lattice structure. It should be observed that these are two distinct surface properties, of which the former must, and the latter may, occur.

Polishing is not the only way in which a surface smooth enough for optical measurements can be prepared. Certain metals, such as zinc and magnesium, in which the structure is hexagonal, can, when in the single crystal form, fracture by cleavage. Such a fracture results in a very bright smooth face, which is always the basal plane of the hexagonal structure. Experiments on the optical properties of single crystals of zinc and magnesium have been carried out by Graber¹ whose results indicate that the optical constants of a single face of the crystal depend on whether the plane of incidence is parallel or perpendicular to an axis of symmetry. There does not seem to be any evidence as to the variation of the optical properties of different crystal faces, *i.e.*, of faces where the atomic density and arrangement are different. The optical constants of liquid metals and alloys have also been investigated, Kent² having made measurements on bismuth, cadmium, tin, lead and mercury, and on binary alloys of these metals.

In general, therefore, it will be seen that it is much easier to investigate the variation with time of optical properties of the surface of a definite specimen than to measure the variation of these properties with composition. The method is one which should prove to be of great value in investigations of surface reactions, especially if the apparatus is so constructed that the temperature of the specimen can be raised. The method could not, of course, be used without considerable modification at temperatures at which the emission of light from the specimen becomes apparent. The thicknesses of surface films, their rate of formation and their stability under various conditions, even where the film is so transparent as to be invisible and so thin that no interference colours are produced, can be measured with considerable precision

¹ Graber, *Phys. Rev.*, 1925, **26**, 380.

² Kent, *Phys. Rev.*, 1919, **14**, 459.

by this method, for which the following arrangement of apparatus is suggested.

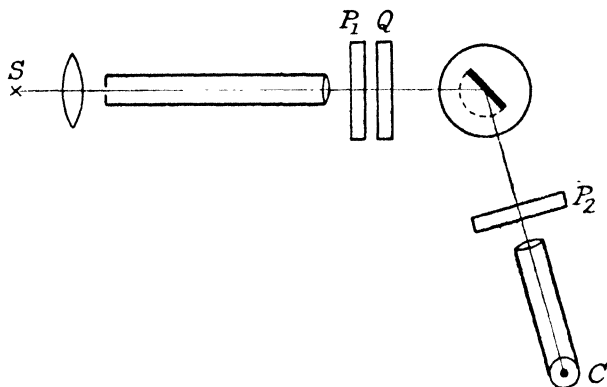

Fig. 94.—Apparatus for Polarimetric Measurement.

Practical Considerations

The basis of the apparatus (Fig. 94) is a spectrometer that must be provided in addition to the usual divided circles for the telescope and table, with rotating mounts for the polariser and analyser (P_1 and P_2) for which polaroid discs are very suitable, as well as for the quarter-wave plate Q . For precision work, the mounts should have fine adjustment screws and divided circles reading to $1'$ of arc. If light of one colour only is to be used, a quarter-wave plate for that colour can be used. If several colours are to be used, *e.g.*, for work on dispersion or on colours of tarnish films, then it is desirable to replace the quarter-wave plate by a Soleil-Babinet compensator which can be adjusted to give any desired phase difference. The source of light S can be either a discharge lamp of the "Osira" type, *e.g.*, sodium or mercury, with appropriate filters for monochromatic light, or else a monochromator, in which monochromatic light of any desired wavelength is isolated from the spectrum produced by passing white light through a prism. In some instruments of this kind the wavelength is read off directly from a drum which controls the position of the prism, the positions of light source and slits remaining fixed. The arrangement is similar to that of a constant deviation spectroscope. The calculation of the

values of the optical constants follows the lines indicated above, but if the variation is required only in a general way, it is sufficient to plot the setting of the polariser or of the analyser. This method saves a good deal of laborious computation and is often adequate.

Photoelectric Methods

The determination of the polariser setting which produces plane polarised light by reflection can be carried out by the ellipticity half shade method, but a much more elegant method is to use a photoelectric cell *C* (Fig. 94) on to which the reflected light is focused after passing through the analyser P_2 . The settings of P_1 and P_2 that are required are those for which the cell gives no response. A very sensitive method of detection of the current may be used in order to obtain accurate readings.

A preliminary account of an application of this method was given by Bor¹ who used a photocell connected to a Lindemann electrometer, the deflection of which indicated the amount of light reaching the cell. The light, plane polarised before reflection, is converted back into plane-polarised light after reflection by means of a Soleil-Babinet compensator, and is then extinguished with an analyser. The settings of compensator and analyser that give the minimum electrometer deflection are used as in the calculation of the optical constants. Difficulties may arise owing to unsteadiness of the source of light. This can be largely compensated by using a second photocell which receives light from the same source. It is stated that the accuracy obtainable by this method compares favourably with that resulting from the visual method of observation.

An ingenious application of the photoelectric cell to investigations of this kind has been described by Kent and Lawson.² In order to determine whether light is exactly circularly polarised, it is directed on to a photocell through a Nicol prism that can be rotated at about 40 revolutions per second. If the light is circularly polarised, it is transmitted with the same intensity at any position of the Nicol prism, and the

¹ Bor, *Nature*, 1937, **139**, 716.

² Kent and Lawson, *J. opt. Soc. Amer.*, 1937, **27**, 117.

current from the photocell does not alter during the rotation of the nicol. If the light is elliptically polarised, the current from the photocell varies periodically, and this can be detected by earphones or by a vibration galvanometer tuned to a frequency that is double that of the rotation. The reason for the double frequency is that the polarising direction of the analyser passes through any given azimuth twice during each revolution.

An interesting method of measuring the optical constants of metals has been described by Williams.¹ The method consists in the photography of the spectra produced by the reflection of polarised light from a grating made by removing parallel strips from a film of the metal concerned on a glass support. The relative intensities of the spectra, determined photometrically from the developed photographs, are used for the calculation of the optical constants. The method, which requires rather specialised apparatus and technique, suffers from the disadvantage that it can only be used for metals in the form of a film on glass (prepared by sputtering or evaporation) which have been ruled to form gratings. Such a surface cannot be regarded as sharing the properties of the pure metal.

Microscopic Methods

The last of Tronstad's five applications of his method (see p. 136) was described as really belonging to the class referred to as microscopic inasmuch as it involved the examination of the surface in detail and not in general. In this particular case, the progress of the spread of one material across the surface of the other was followed by using the fact that the two parts of the surface had different optical properties, and therefore could be distinguished when illuminated with polarised light and viewed through an analyser, although the film was quite invisible by ordinary light. This principle and various extensions of it form the basis of a large number of investigations. An intermediate type, according to the above classification, is also represented by the method used by Chalmers and Jones² in a study of the striated pattern

¹ Williams, *Proc. phys. Soc.*, 1933, **45**, 49.

² Chalmers and Jones, *Trans. Faraday Soc.*, 1935, **31**, 1299.

sometimes produced in the hot-tinning of copper. It was desired to determine whether the material exposed by etching at the site of the striæ was tin or the tin copper compound. The analyser setting required for best extinction, using a fixed polariser setting, was determined for tin and for the compound prepared independently. The etched striated specimen was then inserted and it was found that the setting for best extinction for the striæ corresponded to the value for tin and not to that for the compound. The identification of the phase present in the striations led to a theory explaining their formation.

In the methods which are truly of the microscopic type, plane polarised light is used to illuminate the specimen by means of the vertical illuminator of a microscope, and the specimen is viewed through the microscope, which is fitted with an analyser. The theoretical side of this type of work with polarised light is much more complicated than with the Drude type. The reason is that the surface under examination is illuminated by light whose angle of incidence has all values from 0° (*i.e.*, vertical illumination) up to the maximum permitted by the numerical aperture of the objective, the incident rays forming a solid cone with the result that the plane of incidence makes all possible angles with the plane of polarisation of the light. According to the theory of Drude, light falling normally on an isotropic surface should be reflected unchanged, because in that case there is no resolution into components with their planes of polarisation parallel and perpendicular to the plane of incidence. The only case in which this would not apply is that in which the surface causes rotation of the plane of polarisation as when the surface is magnetised (Keir effect). Depolarisation of the light by scattering may also occur.

Neglecting these two possibilities, it follows that the rays that are not normal to the surface are the ones that will be affected by reflection and that the final result will be the combined effect of all the oblique rays. Assuming that a point on the object receives light at all angles permitted by the aperture of the lens and that all this light eventually reaches a point on the image, after passing through an analyser,

it is necessary to consider how the intensity of light reaching this point is affected by the optical constants of the metal surface.

Consider a plane polarised ray falling on the surface at an angle θ to the normal, the plane of polarisation making an angle ϕ with the plane of incidence (for every angle θ there will be a complete range of values of ϕ). This ray will be reflected so that, if resolved perpendicular and parallel to its plane of incidence, the two components will suffer phase changes which differ by Δ and reduction of intensity in the ratio $\tan \psi$. After reflection these two components can be compounded to form, in general, elliptically polarised light which in turn is resolved into components perpendicular and parallel to the plane of polarisation of the incident light. If the analyser is set so that its direction is perpendicular to that of the polariser, then the component in the original plane of polarisation is not transmitted by the analyser, and so need not be considered further. This includes light at normal incidence and the rays which are reflected unchanged owing to their direction of polarisation being in or perpendicular to their planes of incidence. Such light is obviously not affected by the nature of the surface and it is consequently an advantage to eliminate it by the crossed arrangement of polariser and analyser. The other component (polarised in a direction perpendicular to the plane of polarisation of the incident light) is the resultant of the components of all rays similar to the one discussed above. It should be noted, however, that its intensity cannot be calculated by integrating the intensity of this component over all possible angles because the components will not be in phase owing to the fact that Δ represents only the relative phase change of the two components and not the absolute phase change, which depends on the angle θ for any given surface. The value of the intensity of the light transmitted by the analyser is not, therefore, easily susceptible of calculation and such a calculation would be of little practical value owing to the difficulty of making absolute measurements of the intensity of the image at a point. If such measurements were possible, they would, with suitable calibration, give the optical constants of the material at the point

concerned, and might be made to yield valuable information regarding the variation from point to point of the composition of an alloy.¹ Thus the distribution of the two components in a cored solid solution might be investigated. The difficulty of preparing comparable surfaces, noted in connection with Lowery's work on Drude's method, would further complicate such an investigation. This difficulty is increased by the fact that a polished surface, besides obscuring the structure that should be related to the variations of compositions under consideration, consists of a flowed layer in which there is no reason to suppose that the composition at a point is unaltered by the process of polishing. This suggests that it may be possible to determine how much lateral flow takes place during polishing by using a highly cored structure and examining the variation of composition at various stages of polishing along a line that crosses a crystal.

It should nevertheless be realised that the presence of the polish layer does not necessarily obscure the structure and properties of the underlying crystals. The depth concerned in the reflection process is believed to be at least 1 wavelength (of the order of 400 A.U. or 4×10^6 cm.) and since the effective radii of most metallic atoms approximate to 2×10^{-8} cm., it follows that the depth of 4×10^6 cm., is equivalent to $\frac{4 \times 10^6}{2 \times 10^{-8}}$ atoms, *i.e.*, 200 atoms depth. This

is a rough figure and is only to be taken as a general indication ; but since the depth of the Beilby layer is generally regarded as being about 20 atoms, it follows that the optical properties are not entirely controlled by this layer. Hence non-quantitative investigations with polarised light are often made with polished, but not etched, surfaces. A "shallow" polish is an advantage and this may be obtained by polishing in the ordinary way, then etching so as just to remove the flowed layer, and finally repolishing lightly.

Microscopic investigations with polarised light are carried out under conditions in which the properties of individual crystallites are examined. Whereas the surface of a polycrystalline metal, when viewed macroscopically as in the

¹ Tronstad, *Z. tech. Phys.*, 1932, 9, 408-10.

Drude method, can be regarded as isotropic, the properties representing an average of those of the individual crystallites, the crystallites examined individually are often far from isotropic in their properties.

The theory of the reflection of light from non-isotropic metal surfaces has been considered by Wright,¹ and he concludes that plane-polarised light incident normally on such a surface is resolved into two components, polarised parallel and perpendicular to certain crystallographic directions (the axes of symmetry), and that the phases and intensities of these two components may be changed by different amounts. Such a difference of phase change converts the plane polarised light into elliptically polarised light, and a relative change of intensity rotates the plane of polarisation. The result is, in practice, that a component is produced with its polarisation perpendicular to that of the incident light. This component is observed when the analyser is set so that light reflected by an isotropic surface is extinguished, *i.e.*, in the crossed position. The strength of the component that is transmitted by the analyser in this position depends upon the angle between the axis of symmetry of the crystal and the plane of polarisation of the incident light. If the specimen is rotated while under the microscope, a non-isotropic material (having one axis of symmetry in its surface) will show four minima of brightness, *i.e.*, four positions in which no resolution takes place owing to the plane of polarisation being parallel or perpendicular to the axis of symmetry, with four maxima between them. Thus isotropic and non-isotropic regions of a surface can be distinguished from each other by observing changes of brightness during rotation.

The extent of ellipticity or rotation of plane produced are usually fairly small, and as a consequence, the variations of brightness during rotation will be small. Two methods have been applied for making the effect more readily visible.

Since the effect under consideration is one which takes place with normal incidence, it follows that rays making incidence at other angles may produce undesirable complications, the effect discussed in connection with the microscopic

¹ Wright, *Proc. Amer. Phil. Soc.*, 1919, 58, 401.

method for isotropic surfaces becoming significant. The exclusion of non-axial rays, while eliminating this effect and so increasing the relative changes of intensity of the reflected normal rays, would reduce the amount of light available and so reduce the absolute changes of intensity. Dayton¹ suggests the use of a diaphragm shaped as in Fig. 95, the central part being removed to allow the rays to pass. The diaphragm is placed so as to allow a beam of light of this shape to pass through the objective. It is set with the plane of polarisation in the direction shown by the arrow, and it excludes the rays which would cause the greatest "oblique" effect, since the rays from A, B, C and D are polarised in or perpendicular to their plane of incidence and are therefore

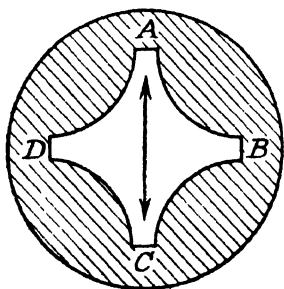

FIG. 95.—Diaphragm for use with Polarised Light.

reflected, by the ordinary isotropic oblique reflection process, with their polarisation unchanged. The only action affecting them is the "non-isotropic" one which is being looked for. This diaphragm therefore utilises only those rays which approximate to the ones which are theoretically desirable, and a considerable intensity of light is transmitted without confusing the result.

The second method of facilitating the application of this technique makes use of the fact that quartz, when cut in a layer making the correct angle with the optic axis, rotates the plane of polarisation of the light passing through it, different colours being affected by different amounts. Thus if plane-polarised white light is passed through a suitable thickness of quartz, an analyser placed after the quartz can only extinguish one colour at a time. The colour seen through the analyser is complementary to the colour extinguished. If the analyser is set so as to extinguish the middle of the spectrum (yellow-green) then the colour seen is a mixture of red and violet, *i.e.*, mauve. A slight rotation of the plane of polarisation of the incident light will cause a change in the colour extinguished, and consequently in the colour observed.

¹ Dayton, *Trans. Amer. Inst. min. (metall.) Engrs.*, 1935, 117, 119.

Applications

Numerous papers have appeared dealing with the practical details and the technical uses of this method, and in the following account no attempt will be made to preserve the chronological order.

The uses to which the polarised light technique have been put are (a) increase of contrast between crystals for the examination of crystal shape and size, (b) identification of inclusions and (c) determination of state of strain.

(a) Increase of Contrast between Crystals

The possibility of examining the structure without etching by utilising the increased contrast afforded by polarised light is confined to the metals which have a non-cubic structure. These include tin, zinc, cadmium and magnesium, of which the first three are important for protective coatings, in which a non-destructive test for crystal arrangement may be of value. In general, however, this particular application of the polarised light method is of little use because it does not yield any information that a suitable etch will not give by ordinary light. Details of the effect of the anisotropy of zinc and the other hexagonal metals, which reflect normal plane polarised light as elliptically polarised light, and of tin, which rotates the plane of polarisation by a degree or so at the most are given by Dayton.¹

(b) Identification of Inclusions

That this is the field in which the method finds its chief applications is shown by the number of publications dealing with it. Two principal effects, which have not always been distinguished, are involved. The first is the one that has already been discussed, namely, the indication of anisotropy by alternations of light and dark during rotation. This only applies to surfaces that are metallic in character. The other effect is that due to non-metallic transparent inclusions. Since the use of crossed polariser and analyser extinguishes the ordinary surface reflection from a non-metal, the light that is seen must be that which has passed downwards through the inclusion and has been reflected from the lower surface

¹ Dayton, *Trans. Amer. Inst. min. (metall.) Engrs.*, 1935, 117, 119.

of the inclusion and the metal in contact with it, and then travelled upwards out of the inclusion. If the metal bounding the inclusion is rough, the light is partly depolarised, and so some light is seen in the microscope. If this is viewed without the quartz or mica plate described above (p.150) it will exhibit the colour of the light transmitted by the material of the inclusion, and this colour will not change as the specimen is rotated. Thus cuprous oxide inclusions in copper appear red under the crossed arrangement of polariser and analyser, although cuprous oxide appears blue by ordinary light where the surface reflection is predominant. Thus a specific colour by transmitted light may serve for the identification of inclusions.

This specific colour is only seen if the surface of the metal surrounding the inclusion is sufficiently rough to reflect depolarised light in sufficient quantity. Unless the reflection is the same for all azimuths of the incident plane-polarised light, the anisotropy of the underlying metal might be detected, and this can give rise to misleading conclusions.

If the inclusion is spherical in shape (flattened on one side by the polishing process) then conditions are altered and reflection takes place from the spherical metal surface surrounding the inclusion. The light is then not incident normally on the metal surface, and the "oblique reflection" effects become important. Since plane polarised light is reflected unchanged only when its plane of polarisation is parallel or perpendicular to the plane of incidence, the light reflected from the inside of the spherical cavity will be extinguished by the analyser only where this condition is satisfied. This is only the case along the arms of a cross parallel and perpendicular to the plane of polarisation of the incident light. The circle which is seen in the microscope therefore shows by a dark cross, maxima of brightness occurring half way between the arms of the cross. Since this cross is formed irrespectively of any anisotropy of the metal or inclusion, it does not rotate when the specimen is rotated. The "Extinction Cross" was described by Hoyt and Scheil¹ for silicate

¹ Hoyt and Scheil, *Trans Amer. Inst. min. (metall.) Engrs.*, 1935, 116, 405.

inclusions in steels, and has also been mentioned by Dayton (*loc. cit.*) and by Schafmeister and Moll.¹ The change of shape of the silicate inclusions (spherical as cast) by forging and rolling, causes the inclusions to show the effects associated with anisotropic inclusions. It was pointed out by Portevin and Castro,² however, that the apparently anisotropic nature of the distorted inclusions is probably not genuine, but may be due to the same cause as the "optical cross," the difference in appearance being caused by the change of shape of the inclusion and not by the appearance of anisotropy.

The identification of inclusions in steel has been considered at length by Schafmeister and Moll (*loc. cit.*) and the following table from their paper³ classifies the structural components of iron and steel from the point of view of their identification by polarised light.

<i>Material.</i>	<i>Composition.</i>	<i>Crystal Structure.</i>
(a) Non-metallic :		
Silicates	$(\text{FeO}, \text{MnO})_n \text{SiO}_2$	Hexagonal, Triclinic
Manganese Sulphide	MnS	Cubic
Iron Sulphide	FeS	Hexagonal
Cobalt Sulphide	CoS	"
Nickel Sulphide	NiS	"
Molybdenum Sulphide	MoS_2	"
Chromium Sulphide	CrS	Unknown
Alumina	Al_2O_3	Hexagonal
Chromite	$\text{FeO}, \text{Cr}_2\text{O}_3$	Cubic
Ferrous Oxide	FeO	"
Ferric Oxide	Fe_2O_3	Hexagonal
Magnetite	Fe_3O_4	Cubic
Beryllium Oxide	BeO	Hexagonal
Aluminium Nitride	AlN	"
Iron Nitride	} Fe_4N } Fe_2N	Cubic
Titanium Nitride		TiN
Zirconium Nitride	ZrN	Cubic
		"
(b) Metallic phases :		
Graphite	C	Hexagonal
Cementite	Fe_3C	Rhombic
Chromium Carbide	} Cr_4C } Cr_7C_3	Cubic
		Trigonal

¹ Schafmeister and Moll, *Arch. Eisenhüttenw.*, 1936-7, 155-60.

² Portevin and Castro, *J. Iron and Steel Inst.*, 1937, 135, 223.

³ This paper is discussed by Monypeny (*Metallurgist*, 1937, 46).

<i>Material.</i>	<i>Composition.</i>	<i>Crystal Structure.</i>
Metallic phases (<i>continued</i>):		
Tungsten Carbides	WC, W ₂ C	Hexagonal
Titanium Carbide	TiC	Cubic
Vanadium Carbide	V ₄ C ₃	? Cubic
Iron Silicide	FeSi ₂	Tetragonal
Compound in FeCr system	FeCr	Unknown
Martensite	—	Cubic and Tetragonal
ε phase in Fe-Mn system	Solid Solution	Hexagonal
Cobalt	α cobalt	Hexagonal
(c) Metallic Coatings :		
	Cd	Hexagonal
	Sn	Tetragonal
	Zn	Hexagonal
	Ni	Cubic

In general, the cubic structure should give no changes of intensity during rotation, while those which are non-cubic should exhibit four alternations of brightness and darkness, the whole surface of a particular inclusion or crystallite having the same appearance at the same time. It may happen in particular cases, however, that non-isotropic crystals are so oriented that their intersection with the polished surface is perpendicular to the axis of symmetry; in such cases the crystal concerned would appear isotropic. It may be possible, as suggested by Schwarz and Daschner,¹ to distinguish between metallic crystals that are uniaxial and those which are biaxial in their optical properties by observations on the colour sequence seen with a suitable optical system. This method does not seem to have been carried far enough to be of any great use in metallography.

Where several types of inclusion are suspected (from chemical or other evidence) it is often possible to determine which are present. For example, Schafmeister and Moll (*loc. cit.*) mention the possibility of distinguishing between manganese sulphide and iron sulphide inclusions in steel, manganese sulphide being cubic, and therefore appearing dark; while iron sulphide is hexagonal and therefore alternates between brightness and darkness when rotated. Similarly iron sul-

¹ Schwarz and Daschner, *Z. Metallk.*, 1936, 28, 343.

phide was distinguished from the oxide in FeS — FeO eutectic. The presence of ferrous oxide in armco iron was found by this method and confirmed by etching with a concentrated alcoholic solution of stannous chloride. Cementite can be seen by polarised light in unetched hyper-eutectic cast iron, showing that it possesses the anisotropic property to be expected from its known structure. An interesting observation by the same authors indicates another aspect of the application of polarised light to metallographic research. In a eutectoid steel having coarse lamellæ, all the lamellæ in the same crystallite appeared bright at the same time during the rotation of the specimen, showing that they share the same orientation. The same effect could not be observed with finely laminated pearlite, globular cementite, sorbite or troostite.

On the non-ferrous side, much work of the same kind has been done, and the possibilities of further applications of the method have been extensively discussed, the contributions of Glaser ¹ and of Schwarz ² being of special importance. Glaser recommends the use of a quartz plate of 3.75 mm. thickness cut perpendicular to the axis for producing colours when the reflected light is elliptically polarised, and several colour photographs in his paper show the elegance of this method of picking out the various constituents in an alloy containing more than one phase. Glaser shows examples of the effects seen with phosphor bronzes and phosphor tins, and discusses the possibility, mentioned above, of making absolute measurements by this method.

Schwarz gives several specific examples of the successful application of the qualitative method, among which are the distinction between cuprous oxide and cuprous sulphide, selenide and telluride by means of the fact that the oxide is transparent and appears red under crossed nicols, while the sulphide, selenide and telluride are opaque and retain their blue-grey appearance. He also describes the investigation of copper containing various amounts of silicon, and shows that silicon, which is isotropic, can be distinguished from the other material present by its behaviour under polarised light.

¹ Glaser, *Z. tech. Phys.*, 1926, 7, 90.

² Schwarz, *Metallurgia*, 1931, 4, 180; *Z. Metallk.*, 1926, 7, 90.

Other examples mentioned are : 50 per cent. arsenical copper, where examination under crossed nicols shows good contrast ; manganic copper, showing whether the iron manganese carbon compound is high ; copper aluminide in copper aluminium alloys ; copper phosphide in an alloy of copper and phosphorus, where twins and glide lamellæ are shown up in polarised light ; and stannic oxide as a constituent in a certain burnt bronze.

Further examples of the application of polarised light as a supplement to ordinary microscopic examination have been mentioned by Eash and Upthegrove,¹ who were able to distinguish a constituent in copper-nickel-tin alloys by polarised light when other methods were useless ; and Baeyertz² mentions the use of polarised light in identifying two types of chromium oxide in steels, their colours being red and green respectively under crossed nicols. Dayton³ describes various cases where polarised light can be used, as in distinguishing cuprous oxide and cuprous sulphide. He points out also that the reason why cuprous oxide sometimes appears to be anisotropic is that it may have a surface layer of cupric oxide, which is anisotropic. Dayton also suggests, in the course of a discussion of the theory of the method, that a single angle of incidence could be obtained by stopping down the iris of the illuminator and decentring the system. If a Soleil-Babinet compensator were introduced into the microscope below the analyser it would be possible to make absolute measurements of the optical constants of the surface in this way. Owing to the small angle of incidence, however, it is not probable that a high order of accuracy could be attained.

In a discussion of the possibilities and limitations of the polarised light method of identifying inclusions, Portevin and Castro⁴ emphasise the importance of maintaining a critical attitude towards the indications resulting from this method of examination. They point out that the identification of

¹ Eash and Upthegrove, *Trans. Amer. Inst. min. (metall.) Engrs.*, 1933, **104**, 220.

² Baeyertz, *Trans. Amer. Soc. Met.*, 1934, **22**, 625.

³ Dayton, *loc. cit.*

⁴ Portevin and Castro, *J. Iron and Steel Inst.*, 1937, **135**, 223 P.

transparent inclusions by their specific colour may be confused by "pleochroic" effects, in which the colour changes with rotation of the specimen. If the inclusion is small, spurious colour effects may also arise from diffraction of the light by which the image is seen. This effect should be revealed by altering the size of the iris diaphragm of the vertical illuminator. The same authors point out that the polarised light method is not the only one by which the effect of the surface reflection of transparent inclusions can be reduced. The alternative methods are to use an immersion objective, in which case the surface reflection is greatly reduced, or to use conical illumination, in which the surface reflection is in such directions that it does not enter the microscope.

(c) State of Strain

The very valuable applications of polarised light in measuring strain in glass and in celluloid models of engineering structures (photoelasticity) has naturally led to attempts to detect and measure strain in metals by this method. Whether this is possible or not is still in doubt because while some workers (Ahmad,¹ Schwarz²) have found that a stressed region appears different from an unstressed area under polarised light, others, for example, Schafmeister and Moll (*loc. cit.*), and Dayton (*loc. cit.*) conclude that stresses and strains cannot be detected with certainty in this way. It is probable that the positive results obtained by Ahmad and Schwarz were indirect, the effect described being that the pearlite in stressed iron and steel is brighter where the material is stressed than where it is not. The explanation may be that the state of strain has some influence on the etching process. If that is so, it is unlikely that any such effect exists in other metals than iron and steel. It must be concluded that at present no real use can be made of the polarised light method for detecting or measuring the strain of metals. In any case, even if the technique could be so improved as to show up the anisotropy that must be produced by strain, it is doubtful if it would have any great value, as the amount of metal

¹ Ahmad, *Forschungsarbeiten über Metallkunde und Röntgenmetallo-graphie*, 1934.

² Schwarz, *Z. Metallk.*, 1932, **24**, 97.

examined in this way is small and subject to special surface conditions. The state of strain which electrodeposited protective coatings often acquire during electrodeposition might usefully be studied in this way, especially if a method were devised whereby the surface could be examined while deposition is proceeding.

Two interesting applications of the polarised light method have been suggested, but apparently no results have been published in either case. It was suggested by Dayton¹ that the state of strain must result from the supposed existence of a mosaic structure if metal crystals could be detected by microscopical examination with polarised light. Since the linear dimension of the "blocks" making up the mosaic is only 10^{-3} to 10^{-4} cm., and the disturbed region would only occupy a small fraction of this, it follows that a high resolving power would be necessary for separating the "disturbed" from the "normal" regions. In addition, the preparation of the surface necessary for microscopic examination at high magnification would, unless extreme precautions were taken, introduce accidental strains of sufficient magnitude to mask the strain due to the mosaic. This would appear to be a case in which the electrolytic polishing method of Jacquet² could be used with advantage, as it entirely avoids the necessity for mechanical action on the surface.

The other suggested application, bearing a superficial resemblance to the one described above, is due to Perrier,³ who points out the possibility of using the Kerr effect (*i.e.*, the rotation of the plane of polarisation of light reflected from the surface of a magnetised body) to prove the existence of the "ferromagnetic mosaic" demanded by the domain theory of ferromagnetism. Perrier states that the rotation produced, in the case of iron, should be $21'$ of arc, which should be detectable. As in the previous case, a good technique would be necessary in order to detect the effect anticipated. Perrier suggests the application of the microscope method of polarised light examination, and also points out that the macroscopic (Drude) method could be applied, the

¹ Dayton, *Trans. Amer. Inst. min. (metall.) Engrs.*, 1935, **117**, 119.

² Jacquet, *loc. cit.* ³ Perrier, *Helv. phys. Acta*, 1936, **9**, 330.

heterogeneous surface giving results differing from those of the more usual homogeneous metal surface. Thus the existence of heterogeneity could be established. This should change when a magnetic field is applied.

Technique

With regard to technique, the following points should be remembered in setting up apparatus for work of this kind. The use of "polaroid" for the polariser and analyser overcomes the difficulty of getting sufficient light which often occurs when Nicol prisms are used. A specially constructed microscope is not necessary, as the polariser can be placed just outside the vertical illuminator, an ordinary lamp being used as the source of light. A disc of polaroid attached to the bottom of the eyepiece by wax is a convenient arrangement, rotation of the eyepiece being used for the setting of the plane of polarisation of the analyser in the required position. It must be remembered that the reflector of the vertical illuminator has its own polarising effect, and in order that this shall not interfere with the plane polarised light admitted by the polariser it is necessary to turn the latter so that its plane of polarisation is parallel or perpendicular to the plane of incidence of the light on the reflector. This can be done by examining a smooth isotropic surface, *e.g.*, glass, having first removed the analyser. If the polariser is rotated, it will be found that the brightness of the reflected light varies. If a position where this is a maximum is chosen, the above-mentioned condition is satisfied. The analyser is then replaced and turned to a position of maximum darkness. If this is not perfectly dark, it may mean that the previous adjustment is not correct or that one of the lenses forming the objective is in a state of strain and is doubly refracting. Such an objective must be avoided. The plate of quartz, gypsum or mica used for observing small rotations of polarisation can be placed below the analyser.

Apart from these practical points, the detailed procedure will depend on the particular problem that is to be studied, and it will be realised that the preparation of suitable specimens, and the conclusions to be drawn from what is observed, must depend upon the particular case.

CHAPTER 6

SOURCES OF LIGHT

Although optical methods are used very largely for examining objects upon which the light falls, there are two very important applications in which information is obtained regarding the source of the light examined. The information forthcoming is about the temperature or the chemical composition of the source. In order to appreciate the possibilities of these methods it is necessary first to examine briefly the processes by which light is produced.

Temperature Radiation

Light is emitted by two processes which for the present purpose can be regarded as quite distinct. The first of these processes is that which takes place when the temperature of any object is raised. If an object, originally at room temperature, is gradually heated, it soon becomes apparent that the object is emitting heat, although no light radiation is yet visible. When the temperature rises further, a dull red glow appears; this changes on heating to bright red, then yellow, and then white. The light that is given out is called temperature radiation, and if certain conditions are satisfied, its colour and intensity are independent of the nature of the substance that is radiating. These facts form the basis of the radiation pyrometer methods of measuring high temperatures. This method of producing light is relatively very inefficient, because the energy consumed is radiated chiefly as heat (infra-red) and only to a small extent as light. The efficiency increases as the temperature is raised.

Characteristic Radiation

The second process by which light is produced is the excitation of the atoms of a gas or vapour either thermally or electrically. An atom consists of a nucleus round which a number

of electrons rotate. The nucleus, which is positively charged, accounts for practically the whole mass of the atom, and the positive charge of the nucleus is balanced by the negative charge of the electrons. These electrons, whose number depends on the particular element concerned, can only travel round the nucleus in certain definite orbits, but electrons can move from one orbit to another, absorbing energy if the transfer is to a "higher" orbit, and emitting energy if it is to a "lower" one. The process of raising electrons to higher orbits is called excitation, and it can be brought about either by raising the temperature sufficiently, when collisions between the atoms will supply the necessary energy, or by passing a discharge of electricity through the space containing the gas or vapour.

When an atom has been "excited" it is able to "radiate." It does so when the electron returns to a lower level. The radiation which is emitted has a definite wavelength which is characteristic of the energy levels occupied before and after the change. Each element has a large number of possible energy levels, and consequently numerous different wavelengths are emitted when a large number of atoms of an element are subjected to conditions that cause excitation. Each element has its own characteristic system of energy levels, and it follows that the wavelengths radiated are characteristic of the element concerned.

When a number of elements are present in the region where excitation is taking place, an examination of the light emitted can therefore be used for determining which elements are present.

Radiation Pyrometry

It has been shown theoretically and proved experimentally that the radiation from a hot body obeys three quite definite laws, which can be expressed most conveniently as follows :

$$(1) S = \sigma\theta^4 \text{ (Stefan's Law)}$$

where S is the energy emitted per square centimetre per second, and σ is a constant depending on the surface and θ is the absolute temperature. Since the hot object will also be receiving some heat from its surroundings, which are at

the temperature θ_1 , the net emission of energy is given by

$$S = \sigma(\theta^4 - \theta_1^4)$$

$$(2) \lambda_m \theta = \text{const.}$$

$$(3) E_m \theta^{-5} = \text{const. (Wien's Laws)}$$

where λ_m is the wavelength which is emitting the maximum energy, and E_m is the energy emitted at this wavelength.

The following important relation must also be appreciated if these formulæ are to be correctly used. When light falls on a given surface it is partly reflected and partly absorbed. If the quantity absorbed is a fraction a of the incident light, then the same surface will at any temperature emit a fraction a of the maximum possible radiation. A body for which $a = 1$ for all colours absorbs all the light which falls on it, and is called a black body. Such a body is also a full radiator, and the constants in the formulæ of Stefan's and Wien's laws have definite values that are applicable to all black bodies. A body for which a is less than one, but is the same for all colours, is called a grey body, and the equation $\lambda_m \theta = \text{const.}$ remains unchanged, while the constants in the other two equations must be modified. If the fraction a is not the same for all wavelengths then the body exhibits a definite colour, and this invalidates all three equations.

An object which is not black can, however, be made to give out the radiation characteristic of a black body if the inside of a cavity with only a small aperture is used as the source. This can be regarded as being due to the fact that if a beam of light shines into such a cavity, it will be reflected backwards and forwards from side to side of the cavity to such an extent that hardly any will be re-emitted by the aperture. Thus the absorption a is practically unity and the cavity acts as a black body. -

There are three types of radiation pyrometer in general use, depending on the measurement of the intensity of the whole or of part of the radiation, or of the colour of the light emitted by the source. These are known as the total radiation, disappearing filament and colour pyrometers respectively.

Total Radiation Pyrometer

The total radiation pyrometer depends on the measurement of the energy of the radiation given out in a given direction

by the hot body. This measurement is made by focusing the radiation on to a small black object of which the temperature is measured. The temperature at which equilibrium is reached, *i.e.*, at which the rate of loss of heat to the surroundings is equal to the rate of gain of heat from the hot body, is measured by means of a thermocouple, the electromotive force produced being measured by means of a suitable microvoltmeter. Two practical considerations should be appreciated. Since the radiant energy emitted by a heated body lies largely in the infra-red part of the spectrum, it is necessary to provide an optical system that does not absorb these rays. Glass lenses cannot be used for focusing the radiation on to the receiver because glass is relatively opaque to the infra-red. It is therefore preferable to use a mirror rather than a lens for focusing, and in practice this method is nearly always adopted.

Secondly, the distance between the pyrometer and the object whose temperature is to be measured is not easily controllable, and the instrument should be designed so that this distance is of no consequence providing it is between certain fairly wide limits. The following consideration shows that providing the image of the hot object covers the receiver, the distance is of no importance. It is required to show that the amount of energy reaching the receiver is independent of the distance between the source and the pyrometer. Since the receiver has a fixed area, the above condition is satisfied if the energy density of the image is independent of the distance. The energy density is obtained by dividing the total energy by the area of the image. The total energy of the image is equal to the energy reaching the mirror (assuming that all the energy reaching the mirror is reflected so as to form part of the image), and this varies inversely as the square of the distance between the mirror and the source. The area of the image of an object of a given size is proportional to the square of the linear size of the image, and the linear size is inversely proportional to the distance between the mirror and the source, providing that this distance is fairly large. Hence, if this condition is satisfied, the energy density is independent of the distance. If the image is large enough to cover the

receiver the energy that the latter receives will be independent of the distance. The distance must be neither too small, since if it is the condition mentioned above will not hold, nor too large, in which case the image would not be larger than the receiver. This type of instrument requires calibration, and this can be carried out by using the melting points of various metals as standard temperatures.

The second type depends on the measurement of the brightness of the light of a given colour, and the choice of a photometric method is governed chiefly by convenience.

The method that is used chiefly in practice is to observe the source of light by means of an image on which is superposed a heated filament. The two are viewed, with suitable magnification, through a colour filter that transmits a fairly narrow band of colour, and the current passing through the filament is altered until the filament can no longer be seen owing to its brightness being equal to that of the background. This current is related to the temperature that is being measured by means of a suitable calibration curve which must be prepared empirically. The effect of distance from the source of light is subject to the same conditions as in the previous case.

Two further methods of measuring the brightness of the light of a given colour are :

(1) The use of a photoelectric cell.

(2) The use of a filament which is maintained at a constant brightness, the disappearance of the filament being brought about by reduction of the aperture through which light comes from the source to form the image, or by the interposition of an optical wedge.

An interesting development of the latter method¹ is to use a filament consisting of two parts which are equally bright only when the current passing through them has a particular value. This makes it unnecessary to use a current measuring instrument for standardising the current in the filament, as this adjustment is made by visual observation.

The disappearance of the filament will take place when the light reaching the eye is of equal intensity from the filament and from the hot source. Complete disappearance

¹ *J. sci. Instrum.*, 1935, 12, 303.

is often prevented by the fact that the whole surface of the filament does not necessarily appear uniformly bright. This is apparently due to two causes,¹ (a) reflection of light from the source by the surface of the filament: this causes an increased brightness at the edges of the filament, and (b) diffraction of light by the edge of the filament, which causes a reduction of brightness at or near the edge of the filament. These two effects, being in opposite directions, tend to cancel, and when the geometry of the instrument is correctly computed, this cancellation may be complete.

Owing to the large number of optical pyrometers based on these principles that are available commercially, it would not serve any useful purpose to attempt a detailed description here. The following consideration, however, applies to all instruments of this type and should be considered in relation to any results obtained. The temperature measured is that of a "black body" which radiates the same amount of light of the wavelength used as the body under observation. If the body is not a black body, then its radiation at a given temperature is less than that of a black body, or its temperature is higher than that of a black body which gives out the same radiation. Thus the "black body temperature" that is given by the pyrometer is lower than the actual temperature of the body. This difference is reduced if the conditions approach those of a black body, either owing to the nature of the surface that is observed or to the existence of a cavity of which the inside is observed.

It may be observed that the lower limit of temperature that can be determined by radiation methods is set by the lowest temperature at which the visible radiation is sufficient for measurement. This limit, which can be taken to be about 750° C., has been extended² down to 350° by using a photographic technique that utilises the infra-red part of the spectrum, and although the difficulties involved are still considerable, it appears probable that this method will prove to be of considerable importance.

¹ Fairchild and Hoover, *J. opt. Soc. Amer.*, 1923, 7, 543.

² Henky and Neubert, *Arch. tech. Messen*, 1936, 62, T100; Neubert, 1936, 63, T114.

An interesting pyrometer which applies the third method enumerated above to the measurement of the temperatures that are important in the manufacture of iron and steel has been described by Naeser.¹ In this instrument the *colour* of the light is measured by passing it through red and green wedges, which can be adjusted to mix the two colours in any required proportion, and the *brightness* by means of a neutral wedge which allows the intensity to be matched with that resulting from a standard black body. When a "grey body" is observed, the colour temperature is correct and the brightness temperature is low by about 50° , while on a metal surface the colour temperature is 20° – 40° low and the brightness temperature 150° C. low. Slight adjustment of the neutral wedge allows the error to be reduced to 10° , the difference of the two temperatures giving some indication of the optical properties of the surface.

Spectrographic Analysis

The technique of spectrographic analysis consists in so acting upon the material to be analysed that it emits its characteristic radiation and then in determining what elements are present, and in what quantities, by an examination of the light. Since the characteristic radiation consists of a number of "lines," *i.e.*, a number of wavelengths, it is necessary to spread out the light so that one wavelength is separated from another. This is usually done by passing the light through a prism that refracts different wavelengths by different amounts. Since the amount of refraction depends on the angle of incidence on the prism as well as on the wavelength, it is essential that the light shall all make the same angle of incidence with the prism. This is brought about by the arrangement illustrated in Fig. 96, in which light from the source S is focused by means of the lens L_1 on to the slit A, which is placed at the principal focus of the lens L_2 . The slit A and the lens L_2 form the collimator of the spectrometer. The light, which is now parallel, reaches the prism P, where it is refracted, the blue end of the spectrum being deviated more than the red end. Each colour still forms a parallel beam of light, but these beams are in slightly

¹ Naeser, *Mitt. K.-Wilh.-Inst. Eisenforsch.*, 1936, **18**, 21.

different directions for different colours. If the light is now passed through a lens L_3 , each colour will be brought to a focus (*i.e.*, an image of the slit) at F . The light reaching F may be examined with an eyepiece or it may be recorded on a photographic plate placed at F .

The spectrum as seen or photographed consists of a number of lines, each of which is an image of the slit, whose positions depend on their wavelengths. The known wavelengths of the lines characteristic of the different elements lead to their identification.

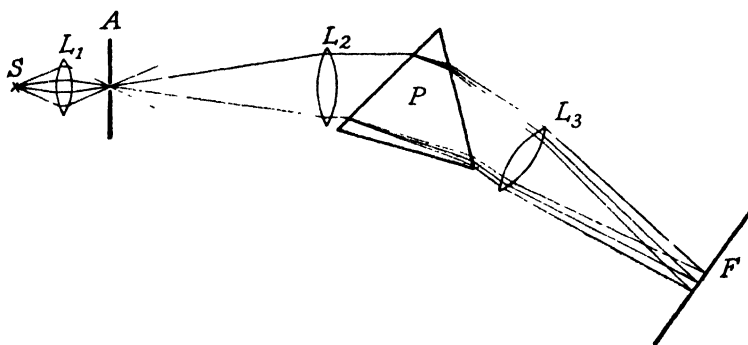

FIG. 96.—Spectrometer.

In discussing the application of these principles to the analysis of metals, the following classification will be made; (*a*) methods of exciting the lines, (*b*) method of photographing them, (*c*) qualitative analysis, (*d*) quantitative technique.

Methods of Excitation

Three methods of excitation have been employed in spectrographic work, namely by heating the sample in a flame or in an electric arc or by causing a spark to pass between it and another electrode; for metallurgical purposes attention can be confined to the arc and spark methods. The choice of one or other of these methods depends largely on the type of analysis that is required, and further consideration will be given to this aspect under the heading of "quantitative analysis."

In the arc method of excitation, the sample under examination serves as one electrode, and for the other a rod of graphite or of any spectroscopically pure metal may be used, including, of course, the main constituent of the alloy under test. For

example, when copper or copper alloys are being examined, the second electrode may be of copper, and when the sample is of steel pure iron may be used. An alternative, recommended by some exponents of the method, is to use two electrodes of the sample. The most recent publication on this subject¹ advises that one electrode only should be of the material to be tested. The electrodes are in the form of rods of about 5 mm. diameter, and are shaped to form cones of about 80°. The points must be cleaned with a file or other suitable tool after each exposure in order to avoid contamination. The electrodes are fixed vertically and in line with each other, and the arc is struck by bringing the electrodes together and then separating them to the required distance, for which 4 mm. is recommended. A direct current source of about 120 volts is required, and it is agreed by most of the investigators who have studied the method that it is preferable to make the sample the negative pole of the arc. If the sample is too small or of too low a melting point to be used as an electrode, it may be placed in a crater in a graphite electrode, the arc being struck in the usual way. This is often referred to as a "globule" test.

When the spark method is adopted, the electrodes are connected to a high-tension alternating current supply instead of to a direct current supply. A transformer with a condenser in parallel and in some cases an inductance in series is used as the source of supply. Barker recommends the use of a condenser of capacity 0.005 microfarads, and no added inductance. With this circuit a spark gap of 2 mm. was found to be suitable. An upper electrode of graphite is preferable to a metal. The upper electrode should be shaped as for the arc method, while the specimen under test is used as the lower electrode. A voltage of 15,000 was used in the experiments described by Barker, and was found to yield very satisfactory results.

It should be realised that the arc and spark spectra of an element are considerably different from each other. The reason is that in the arc, the excitation of the atoms is brought about by the high temperature that prevails, the electric

¹ Barker, *J. Iron and Steel Inst.*, 1939, Advance copy.

current merely causing the high temperature, whereas in the case of the spark spectrum, the excitation is caused by the discharge of electricity itself. It is therefore usual to refer to the arc spectrum and the spark spectrum of an element as two entirely different spectra.

Method of Photography

Although a certain amount of qualitative information can be obtained from a visual examination of a spectrum, far more detailed analyses can be obtained from photographs of spectra. The reasons are three: (1) wavelengths can be measured much more accurately from a photograph; (2) intensities can be compared far more precisely; (3) lines can be seen on a photograph which are not visible in the spectrum itself, either because they are in the ultra-violet region or because they are too faint. At the same time, there are many purposes for which visual examination is sufficient, and in these cases the time saved may be of more importance than the extra data obtainable from photographs. An example of the type of instrument designed for visual use is the Hilger Spekker Stelescope, in which a calibrated scale enables the most important elements likely to be found in steels to be identified immediately. Rough quantitative comparisons of samples of fairly similar compositions can also be carried out with this instrument.

Since the possibility of utilising the ultra-violet region of the spectrum is one of the main advantages of the photographic method, it is necessary to use an optical system that is as transparent as possible to the ultra-violet radiation. The material usually used for the lenses and prism is quartz, as this transmits the whole of the visible spectrum and the ultra-violet down to a wavelength of 2000 A.U. The general layout of one form of the instrument is as shown in Fig. 97 in which the source of light is represented as S, focused by the condenser C on to the slit A through which the light enters the instrument proper. The lens L_1 renders the light parallel, and the prism P disperses the light owing to the variation of the refractive index with wavelength. The lens L_2 focuses each wavelength to form an image of the slit on the photographic plate or film F. It will be noticed that

the plate is inclined to the axis of the lens L_2 ; this is because the variation of refractive index with wavelength causes L_2 to have a different focal length for each wavelength, the focal length increasing as the wavelength decreases. The inclination of the plate is so arranged that all wavelengths from 2000 A.U. to 8000 A.U. focus on it approximately. As extremely critical focusing is generally required, it is necessary also to bend the plate or film slightly so as to allow exactly for the focusing of each wavelength.

Since each line of a spectrum is in fact an image of the slit it is evident that the sharpness or fineness of a photograph

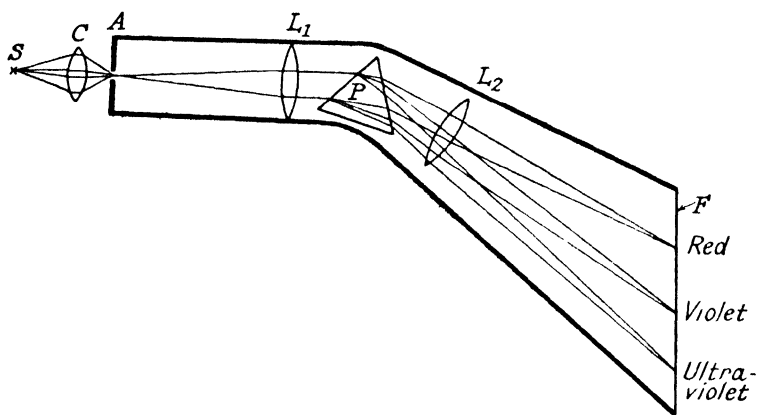

FIG. 97.— Quartz Spectrograph (diagrammatic).

of a spectrum will depend to a large extent on the width of the slit. A narrow slit produces fine lines of low intensity, while a wider slit will give broader and brighter lines. Barker¹ recommends a slit width of 0.015 mm. The width of the spectrum (*i.e.*, the length of the lines) depends on the length of the slit, and an adjustment is usually provided so that this can be set at any desired value. The advantage of using a short slit length (*e.g.*, 2.5 mm.) is that a number of spectra can be photographed side by side on the same plate. For this purpose a mechanism for moving the plate transversely to the spectrum by the required amount is incorporated in the instrument.

Since the spectrograph is an instrument that will almost

¹ Barker, *loc. cit.*

certainly be purchased complete and not constructed by an individual investigator, it is not proposed here to discuss the details of construction or manipulation. All that is intended is to describe the principles involved so that the possibilities and limitations of the method can be appreciated.

Qualitative Analysis

The visual method of qualitative analysis has already been mentioned, and it will be obvious that the identification of elements in this way is severely restricted. In the photographic method, the spectrum of the material to be analysed is viewed in such a manner that it can be compared with a standard spectrum. This may be done by means of the Judd Lewis comparator, which is a microscope with its optical system so arranged that the two spectra are seen side by side. The standard spectrum has certain lines marked on it, and the presence or absence of these lines establishes the presence or absence of the corresponding elements. An alternative method is to use a comparison spectrum of iron, on account of the large number of lines in the spectrum of iron. A knowledge of the wavelengths of the lines in the iron spectrum allows the wavelengths in the unknown spectrum to be determined by interpolation. Reference to tables of wavelengths¹ leads to the identification of the unknown elements.

Since the chief importance of the spectrographic method is for the identification of minor constituents, it is of interest to consider the lower limits of concentration that can be detected. Although the full spectrum of any element consists of a large number of lines, the number of lines that can be observed diminishes as the concentration is reduced, until eventually only a single line remains. This line is called the *raie ultime* or R.U. of the element concerned, and it is in general the only line that need be sought if the presence or absence of a particular element is to be established. A comparison spectrum obtained with, for example, Ryde and Jenkins R.U. powder,² in which fifty elements are present

¹ *E.g.*, Twyman and Smith, *Wavelength Tables for Spectrum Analysis*, Hilger, 1931.

² Ryde and Jenkins, *Sensitive Arc Lines of 50 Elements, including notes on the Use of the R.U. powder in Spectroscopic Analysis*, Hilger, 1920.

in such proportions that only their R.U. appears, can be used for determining which elements are present by inspection. By methods such as this, all the metals and some non-metals such as boron, arsenic and phosphorus can be detected. Some non-metals such as sulphur, permanent gases and acid radicals cannot be dealt with in this way.

The degree of dilution that causes the disappearance of the R.U. is the limiting amount that can be detected; this varies with the element concerned and also depends on the conditions of excitation, because a line becomes invisible when its intensity is not great enough compared with that of the background of diffuse light that cannot be entirely eliminated. In general the lower limit may be said to vary between 0.001 per cent. and 0.00001 per cent.

Quantitative Analysis

The study of the possibility of using the spectrochemical method for quantitative analysis has been practically confined to the determination of minor constituents, generally in the quantities characteristic of impurities, but more recently in rather larger quantities as alloying elements. The reason for this restriction is that the accuracy of the method is not very high, the limit being, until recently, 10 per cent. of the quantity of a constituent present. Where the quantity is small, this accuracy is adequate, but for larger quantities the chemical methods are more satisfactory.

The most obvious method of making quantitative analyses by the spectrochemical method would be to compare a spectrum of the material under test with a series of spectra obtained with samples containing known amounts of the impurity that is to be determined. This method has been applied with marked success in certain cases, but its utility in a wider field is restricted by the fact that it is necessary to exercise very rigid control over the conditions in which the spectra are photographed, and it is in general necessary to have a very large supply of standard spectra.

For these reasons, the method mentioned above, the "external comparison" method, has been largely superseded by the "internal comparison" technique. In its simplest form, this consists in comparing the intensity of a line of

the element that is being estimated with that of a line of a major element. The first essential is that the conditions of excitation shall be standardised, and while some workers find that control of voltage, spark or arc gap, shape of electrodes, exposure and the development of the photographic plate are sufficient to ensure accuracy, others favour the observation of a pair of lines in the spectrum of a major element which are only equally intense under definite conditions. This check on the conditions of excitation is called the "fixation pair." The next stage is to prepare a series of samples containing various quantities of the constituent that is to be determined. The spectra of these samples are photographed under the standard conditions, and in each case it is usually possible to find a line of the impurity of equal intensity with a line of the major constituent. Such lines are called a "homologous pair." The following example, quoted from Barker, is part of a table prepared for the determination of bismuth in brass.

Bismuth %	Bi Line 3068	Bi Line 2898
0.0007	= Cu 3088
0.002	= Cu 3116
0.005	= Cu 2892
0.007	= Cu 3074

Thus when the spectrum has been photographed under standard conditions, the intensity of the bismuth line of wavelength 3068 A.U. is compared with the neighbouring copper lines by means of the comparator. If, for example, it is of equal intensity to the copper line 3088, then the percentage of bismuth is 0.0007. If the bismuth line 3068 is darker than the copper line 3116 A.U. but lighter than the line 3074, then the bismuth line 2898 is examined. If it is equal to the copper line 2892, the percentage is 0.005.

This method of analysis, for which the arc method of excitation was used, has been applied with great success to the determination of impurities in non-ferrous alloys. The following figures, quoted from Barker's paper, show the limits between which the method has been applied at the Admiralty Laboratory, Sheffield. In brasses the following elements are estimated between the percentages given: lead, 0.005-0.20;

bismuth, 0.001–0.007 ; antimony, 0.003–0.03 ; arsenic, 0.005–0.05 ; iron, 0.005–0.12 ; nickel, 0.005–0.16 ; silver, 0.005–0.02 ; aluminium, 0.002–0.20 ; manganese, 0.002–0.20 ; tin, 0.005–0.20 ; cadmium, 0.005–0.02. These figures, which are typical of others given in the same paper, do not indicate the limits of the method, but merely the limits between which the method is actually used as a routine method of analysis.

The most important limitation to the accuracy of this method is due to the fact that the eye is not capable of detecting small differences in the intensities of the lines of the photograph of a spectrum. A better method of comparing the intensities of the lines is therefore required if more accurate results are to be obtained. The most widely used method by which this has been accomplished is that of the log sector. In this method, the light passing through the slit is partially obscured by a rotating disc, of which the periphery is cut so that the light passes through different parts of the slit for different fractions of the total time of the exposure. The disc, which is placed just in front of the slit, is shaped so that the exposure varies logarithmically along the slit. As a result of the characteristics of the response of the photographic emulsion to light, this results in the apparent length of the line being proportional to the intensity, and therefore, other things being equal, to the amount of the element present. The main difficulty in using this method for comparing the intensities of lines of major and minor components is that the point at which a given line disappears is not definite, but depends upon the observer. For this reason, a completely objective method of measuring the intensities is found to be much more satisfactory. The following method, described by Barker in the paper already referred to, is the most successful that has been devised so far. The basis of the method is to compare the intensity of a line of the element to be determined with that of a line of a major component for a series of alloys of known composition. This comparison is made by means of a photoelectric micro-photometer, in which a source of light is focused on to the plate on which the spectrum has been photographed, and the transmitted light is measured

by means of a photoelectric cell. As the spectrum is moved across the light beam, the deflection of the galvanometer that is operated by the photo-electric cell indicates how much light is being absorbed by the spectrum. Thus the degree of blackening of the plate at the position of any given line can be determined.

A calibration graph is then prepared, plotting the logarithm of the ratio of the intensities against the composition. This graph is used for determining the quantity of the element present in any alloy that is similar, as regards the major constituents, to the calibration alloys. While this procedure is very simple in principle, there are a number of points that must be attended to if the greatest possible accuracy is to be attained. It has been found by Barker that the spark method of excitation is far better than the arc method for this type of work, and a very rigid standardisation of the conditions of excitation and exposure and development are necessary for good results. The choice of the comparison lines is important, and in general it is preferable to choose lines that are of equal intensity somewhere in the range of compositions that it is proposed to study. The effects of departure from the standard conditions of the exposure, the time and temperature of development, of preliminary sparking before the exposure is made, and of variations of the shape and material of the upper electrode are all analysed in the paper cited, and it may be stated that unavoidable departures from perfect standardisation do not cause serious errors; the following table shows the maximum quantities of the various elements in steels that can be analysed by this method, and the accuracy at the stated percentage.

Accuracy Attainable at Percentage Shown

	Si %	Mn %	Ni %	Cr %	Mo %	V %	Ti %	Co %	Cu %	Al %
Content . .	0.30	0.80	3.50	0.80	0.70	0.25	0.10	0.10	0.10	0.05
Accuracy . .	0.02	0.05	0.10	0.04	0.05	0.02	0.02	0.02	0.02	0.01

In order that this accuracy may be attained, it is necessary to avoid errors due to heterogeneity of the material. Since

the material to be analysed forms the lower electrode, and the spark passes at a very restricted part of the surface, the result of one exposure is not likely to be characteristic of the material as a whole. The procedure that was adopted was to take three separate exposures with the sample in different positions, and to take the mean of the three results if they did not differ by more than a certain amount; if they differed by a larger amount, the process was repeated. This procedure gave very close agreement with the results of chemical analysis.

A method that has been proposed by Barker but not yet fully worked out is to eliminate variations due to segregation by making a composite photograph by means of a number of short exposures on different parts of the specimen, so that the spectrum is the average of the different points concerned. This should go a long way towards eliminating errors due to segregation. A development of the technique is the determination of the nature of segregates by so positioning the sample that the spark passes to a segregated part of the material. Definite difference in composition between segregated and non-segregated parts were established.

In general it may be stated that when a large number of routine analyses have to be made on similar materials, the saving in time that would result from the use of spectrographic instead of chemical analysis is very considerable and the accuracy is not seriously diminished. As an example, Barker states that twelve samples of nickel-chromium-molybdenum steel can be analysed spectrographically by one man in less than one day for silicon, manganese, nickel, chromium, molybdenum, vanadium, aluminium and copper. This is undoubtedly very much faster than the chemical method; the saving in materials is also considerable, but against this is the high initial cost of the spectrographic apparatus.

INDEX

- Absorption (of light), 13, 29
Adsorption, 135
AHMED, 157
Alloys, colour of, 140, 141
Aluminium, black stain on, 15
 as reflector, 22
Analyser, 121
ANDRADE, 28, 29, 30, 32
Angstrom unit, 4
Arc spectrum, 168
Atmospheric oxidation, 134
AUSTIN, 63, 67
- Babinet compensator, 127, 133
BAEYERTZ, 156
BARKAS, 13
BARKER, 168, 170, 173, 174, 175,
 176
BARNARD, 116
BEILBY, 138
BERGMANN, 22
Biplate, 122
Biquartz, 122
Black body, 27, 162
 — temperature, 27, 165
Black stain on aluminium, 15
BOR, 144
BORGMANN, 136
BRIDGMAN, 9
Brightness, 17, 18
- CANAC, 13, 16
CASTRO, 150, 153
Cathodic sputtering, 29
CHALMERS, 10, 11, 12, 56, 69, 73,
 75, 99, 108, 145
Characteristic radiation, 160
Circularly polarised light, 125
- Cleavage faces, optical constants
 of, 142
Colour, 2
 of copper, 20, 22
 of copper-nickel alloys, 22, 23
 of films, effect of angle of
 incidence, 85
 pyrometer, 166
Colours of films on steel, 91
 of metals, 13, 20
Comparator, Judd Lewis, 171
Compensator, Jamin-Babinet, 139
 Babinet, 127, 133
 Soleil-Babinet, 128, 133, 143,
 144, 156
Condensation of thin films, 29
CONSTABLE, 89, 91, 94, 95
Contorograph, 7
Copper, colour of, 20, 22
 nickel alloys, colour of, 22, 23
CORNU, 101
Crystal orientation, 9, 11, 14
Curie point, 27
CUTHBERTSON, 56
Cutting edge, shape of, 74
- Dark ground illumination, 30
DASCHNER, 154
DAVIDENKOV, 73
DAVIES, 55
DAYTON, 150, 151, 153, 156, 157,
 158
Decorative purposes, 17
DIGBY, 16, 19
Diffraction, 102
 grating, 107
Diffuse reflection, 13, 22
Diffusion of light, 13

- Dilatometers, 62
 accuracy of, 65
 Disappearing filament pyrometry, 164
 Domains, ferro-magnetic, 158
 DRUDE, 130, 136, 137

 EASH, 156
 EDWARDS, 33, 64, 96
 EGEBERG, 17
 Elastic constants, measurement of, 101
 Electrodeposited layers, thickness of, 98
 Electrolytic polishing, 14, 139, 158
 Electron diffraction, 28, 138
 Elliptically polarised light, 124
 — — analysis of, 126
 Ellipticity half-shade, 129, 132, 133
 EVANS, 80, 82, 84, 89, 91, 97
 Extinction cross, 31, 152

 FAIRCHILD, 165
 FARADAY, 28
 FEACHAM, 136, 137
 Ferro-magnetic domains, 158
 Films, colour of, 76
 colour, theory of, 76
 growth of, 16
 metal, 95
 mono-molecular, 135
 on steel, colour temperature relation, 91
 oxide, colours of, 83
 — thickness of, 137
 relation between thickness and colour, 78, 89, 90
 FISCHER, 15
 FIZEAU, 62
 Fluorescence, 24
 Foils, thickness of, by interference, 98
 Frequency, 1, 2
 Fuess spectrometer goniometer, 139

 GALE, 97
 GARNETT, 30
 GELLER, 15
 GHOSH, 96
 GLASER, 155
 Globule test, 168
 Gold films, 30
 leaf, 28
 GRABER, 142
 Grey body, 162
 GROOM, 108
 GUERTLER, 22

 HAITINGER, 24
 Half-shade, 122
 HAMAKER, 26
 HARTZLER, 33
 HENKY, 165
 Hilger Spekker steeloscope, 169
 HOARE, 8, 69, 73, 75, 99
 HOGE, 11
 HOLLADAY, 63, 67
 HOOVER, 165
 HOVERSTAD, 136
 HOYT, 152
 HUTCHINGS, 11

 IAKUTOVITCH, 73
 Inclined plate system, 41
 Inclusions, classification of, 163
 identification of, by polarised light, 151
 Interference, colours, 33
 fringes, applications of, 52
 — brightness of, 44
 — contrast of, 44
 — sharpness of, 44
 reflected light, 35
 thermometer, 66
 transmitted light, 38
 Interferometer, adjustment of, 67
 optical system of, 68

 JACQUET, 14, 139, 158
 JAMIN, 88
 Jamin-Babinet compensator, 139
 JENKINS, 171

- JONES**, 11, 145
Judd-Lewis comparator, 171

KANABY, 95
KENT, 123, 142, 144
KENWORTHY, 17, 19
Kerr effect, 146, 158
KINDER, 74
KOEFOED, 26
KUNDT, 86, 95

Laws of reflection, 13
LAWSON, 144
LEWIS, 171
Linnik-Zeiss micro-interferometer,
74
Liquid metals, optical constants of,
142
LOWERY, 138, 139, 141
LUCKIESCH, 63, 67
Lummer Brodhun photometer, 19

McKEEHAN, 11
**Magnetic transformation temper-
ature**, 27
MALLOCK, 89, 97
MARTINDALE, 28, 29, 30, 32
**Mesh, measurement of by diffrac-
tion**, 108
Metal films, colours of, 95
— changes in, 33
— crystallisation of, 30
— formation of, 32
— transparency to ultra-violet,
33
Metallography, 23
Michelson interferometer, 50
**Micro-interferometer, Linnik-
Zeiss**, 74
Microscope, resolving power of,
111
Micro-topography, 69
— applications of, 71
Migration, surface, 136
MILEY, 91, 92
MITSCHE, 24, 25
MOLL, 153, 154, 157

Monochromatic light, 40
Mono films, 135
Mono-molecular films, 135
MONYPENY, 153
MOORE, 138
Morin, 25
MOTT, 141

NAESER, 166
NATHANSON, 95
NEUBERT, 165
Newton's rings, 53
Nicol prism, 120, 159
Non-isotropic metals, 149

Optical lever, 6
— **pyrometer**, 27
ORNSTEIN, 26, 27, 34
OVERBECK, 95
Oxidation, atmospheric, 134
Oxide films, colours of, 83
— thickness of, 137

Parallel plate system, 38
— — application of, 40
Passivity, 134
PERRIER, 158
PETERSEN, 33
Phase, effect of, 36
PHILLIPS, 40, 73
Photoelectric cell, 18, 19, 21, 22,
144, 164
Photometer, Lummer Brodhun, 19
**Plane bending apparatus (Cuth-
bertson)**, 60
Poisson's ratio, 101
Polarised light, 30, 87, 117
— applications of, 130
— application of microscopic
method, 151
— contrast between crystals,
151
— detection of, 121
— — of strain, 157
— identification of inclusions,
151
— microscopic methods, 145

- Polarising angle, 88
 Polaroid, 121, 159
 Polishing, electrolytic, 14, 139, 158
 POLLARD, 40, 73, 74
 PORTEVIN, 19, 153, 156
 Powders, size of, by diffraction, 110
 Precision extensometer, 57
 PRESTON, Theory of Light, 107, 111
 PRICE, 22, 93
 PROMISEL, 17
 Propagation of light, 35
 PROSAD, 96
 PULLEN, 22
 Pyrometer, colour, 166
 disappearing filament, 164
 total radiation, 162
 Pyrometry, radiation, 161

 Qualitative analysis, spectro-graphic, 171
 Quantitative analysis, spectro-graphic, 172
 Quarter-wave plate, 130
 Quartz spectrograph, 170

 Radiation, characteristic, 160
 pyrometry, 161
 temperature, 160
Raie ultime, 171
 RAMA SWAMY, 29
 RAYLEIGH, 111
 Reflecting power, 12
 Reflection, depth of penetration in, 148
 laws of, 5
 Reflectivity, measurement of, 16, 19
 Refraction, 119
 Resolving power of microscope, 111
 Rigidity modulus, measurement of, 55
 ROSCOE, 11
 RYDE, 171

 Scatter, 13
 SCHAFMEISTER, 153, 154, 157
 SCHEIL, 152
 SCHWARZ, 154, 155, 157
 Screens, mesh of, by diffraction, 108
 SEARLE, 54, 101
 Shape of surface, 8, 11, 13
 SHAW, 7
 Sidol, 25
 Silver leaf, 28
 tarnishing of, 93
 SINDEN, 63, 67
 Slip bands, 11
 Slit, diffraction at, 105
 SMARE, 139, 141
 SMILES, 115
 SMITH, 64, 171
 SMOLUCHOWSKY, 32
 Soleil-Babinet Compensator, 128, 133, 143, 144, 156
 Spark spectrum, 168
 Specular reflection, 13, 22
 Spectra, photography of, 169
 Spectrograph, quartz, 170
 Spectrographic analysis, 166
 — qualitative, 171
 — quantitative, 172
 Spectrum, 2
 electromagnetic, 3
 Spekker Steeloscope, 169
 Spherulet, 31, 32
 Spherulite, 31
 Sputtering, cathodic, 29
 STARKY, 32
 Steeloscope, Spekker, 169
 Stefan's Law, 161
 Strain, detection of, by polarised light, 157
 SUMMERS, 96
 Surface migration, 136

 TAIT, 99
 TAMMAN, 89
 Tarnish, 15
 TAYLOR, 64
 Telescope, action of, 39

- Temperature radiation, 160
Thickness of film, definition of,
 92
Thin films, 28
THOMAS, 22, 93
Tin, 10
Tinplate, 8, 14, 15
Total radiation pyrometer, 162
 reflecting power, 26
TRONSTAD, 129, 131, 132, 133, 136,
 137, 148
TWYMAN, 171
- Ultra-violet microscopy, 115
 spectrum, 169
UPTHEGROVE, 156
- VAN DER VEEN, 26, 27
VERNON, 16, 19, 93
Visual estimate of surface bright-
 ness, 22
- WALDRAM, 17, 19
Wave motion, 1
Wavelength, 2
WELCH, 116
Wien's laws, 162
WILKINSON, 139, 141
WILLEY, 64
WILLIAMS, 145
WILLIAMS, *Applications of Inter-*
 ferometry, 41
WINTERBOTTOM, 133
Wire, thin, diffraction at, 105
Wires, thickness of by interference,
 98
WRIGHT, 149
WRIGHTON, 115
WOOD, 95
- YOUNG, 110, 111
Young's modulus, 101
 — measurement of, 54, 55

