

UNIVERSAL
LIBRARY

OU_156516

UNIVERSAL
LIBRARY

OUP—730—28-4-81—10,000.

OSMANIA UNIVERSITY LIBRARY

Call No. 538.8

Accession No. 11325

Author

W 18 A

Wall, T.F.

Title

Applied magnetism.

This book should be returned on or before the date last marked below

APPLIED MAGNETISM

APPLIED MAGNETISM

BY

T. F. WALL

D.Sc., D.ENG., M.I.E.E., A.M.INST.C.E.

HEAD OF THE ELECTRICAL ENGINEERING DEPARTMENT, UNIVERSITY
OF SHEFFIELD



LONDON

ERNEST BENN LIMITED

BOUVERIE HOUSE, FLEET STREET

1927

Richard Clay & Sons, Ltd., Printers, Bungay, Suffolk.

PREFACE

TWENTY years ago it was a commonplace remark that “ (Applied) Electricity is in its infancy.” To-day it is certainly true to say that Applied Magnetism is in its infancy.

In recent years the theory and practical applications of magnetism have been studied very closely by a large number of investigators, and the results of this intensive research have been particularly fruitful in helping to solve some of the problems relating to permanent magnets. Special steels are now available having magnetic characteristics which would have been considered fantastically impossible fifteen years ago. For example, in his classical paper read before the Institution of Electrical Engineers at Glasgow in June 1912, the late Prof. S. P. Thompson made the following observation: “ The ideal sought for at the present time is a steel of such composition that, when properly treated, it shall have a remanence of 800 and a coercive force of 80. *No such steel has yet been produced*; but assuredly it is not unattainable. And with the great modern advance in metallurgical knowledge, it is not beyond the bounds of hope that some day a steel may be produced with a remanence of 1000 and a coercive force of 100.” To-day, steels are available, and are used, having a remanent intensity of magnetisation of over 900 and a coercive force of over 200.

The results obtained with the recently introduced alloys known as “ permalloy ” appear likely to produce a revolutionising effect in their application to submarine cable work.

When such great strides have been made in so short a time it is reasonable to expect that this rapid rate of development will be at least maintained.

Magnetic methods of analysis of materials and magnetic tests for mechanical strength of materials are being rapidly developed by a number of workers, and the results already obtained show that testing the strength of steel wire hauling ropes, testing for flaws in cutlery blades, drills, etc., will be commercially possible at no very distant date. The great practical value of such applications of

magnetic testing is obvious and the principles on which these methods are based are briefly outlined in Chapter XVI.

In view of the wide and increasing industrial importance of magnetism, it appeared to the writer that a need exists for a book of moderate size which would give a reasonably complete survey of this branch of electrical engineering. The present book has been written in the hope that it will help to meet this need.

In the first part of the book the principles of applied magnetism are considered and a brief account of the electron theory of magnetism is included, which theory, incomplete as it may be, is undoubtedly a very great stimulus to the imagination. The fact of magnetism is indeed so remarkable that it appears strange to find the study of magnetic phenomena to have been relatively badly neglected until quite recent times.

Very intense magnetic fields are now available, and there is good reason to believe that researches made by means of these intense fields will lead to other results of both theoretical and practical importance. A brief account of some recent work in this direction is given in Chapter VIII.

In the second part of the book various methods of magnetic testing are considered. Although in a book of this kind it is impracticable to deal with all the available methods, it is hoped that a reasonably representative selection has been made so as to include the tests which are likely to be most generally reliable and useful in practice.

Whilst the proofs have been read with great care, it is perhaps too much to hope that no error has passed uncorrected, and the author will be grateful for information of any slip which may remain undetected.

T. F. W.

Sheffield,
December, 1926.

CONTENTS

PAGE

PREFACE	v
-------------------	---

PART I

THE PRINCIPLES OF APPLIED MAGNETISM

I. DEFINITIONS—ENERGY OF THE MAGNETIC FIELD—MOLECULAR THEORY OF MAGNETISM—AMPÈRE'S CURRENT RINGS	9
II. THEORY OF PERMANENT MAGNETS	38
III. SOME METALLURGICAL FACTS AND THEIR RELATIONSHIP TO THE MAGNETIC PROPERTIES OF IRON AND STEEL	55
IV. SOME CHARACTERISTICS OF MAGNETIC SUBSTANCES	72
V. THE RELUCTIVITY RELATIONSHIP—THE FRÖHLICH-KENNELLY EQUATION	93
VI. MAGNETO-STRICTION—EFFECT OF MECHANICAL STRESS ON MAGNETISATION	101
VII. THE ELECTRON THEORY OF MAGNETISM	111
VIII. THE GENERATION OF VERY INTENSE MAGNETIC FIELDS	124

PART II

MAGNETIC TESTING

IX. THE BALLISTIC GALVANOMETER: THE FLUXMETER	139
X. DETERMINATION OF THE MAGNETISATION CURVE AND THE HYSTERESIS LOOP: (I) BY THE METHOD OF REVERSALS; (II) BY THE "STEP-BY-STEP" METHOD	155
XI. BAR AND YOKE METHOD OF MAGNETIC TESTING: THE BURROWS DOUBLE BAR AND YOKE PERMEAMETER	167
XII. MAGNETIC TESTING IN INTENSE FIELDS	187
XIII. DETERMINATION OF THE MAGNETISATION CURVE AND THE HYSTERESIS LOOP BY THE MAGNETOMETER METHOD	201
XIV. TOTAL LOSSES IN IRON LAMINATIONS: MEASUREMENT BY MEANS OF THE MAGNETIC SQUARE: SEPARATION OF THE LOSSES	215
XV. SCOTT'S METHOD FOR OBTAINING THE HYSTERESIS LOOP FOR TRANSFORMER CORES	233
XVI. TESTING OF PERMANENT MAGNETS: TESTING FOR MECHANICAL AND OTHER DEFECTS IN STEEL BY MAGNETIC METHODS: TESTING FEEBLY MAGNETIC SUBSTANCES	239
INDEX	259

THE PRINCIPLES OF APPLIED MAGNETISM

CHAPTER I

DEFINITIONS—ENERGY OF THE MAGNETIC FIELD— MOLECULAR THEORY OF MAGNETISM—AMPÈRE'S CURRENT RINGS

1. Coulomb's Law

THE law of the mutual action between magnetic poles was first stated by Coulomb and may be expressed as follows :

If two magnetic poles of strength m and m' respectively are placed in air and separated by a distance d cm., the force with which each pole acts on the other is given by the expression

$$\frac{mm'}{d^2} \text{ dynes}$$

If the poles are like magnetic poles the force is one of repulsion, and if the poles are unlike the force is an attraction.

From the above expression the definition of unit magnetic pole follows, viz. :

Unit magnetic pole is such that, when placed in air at a distance of 1 cm. from a precisely similar pole, it is repelled with a force of one dyne.

In order that this definition should be precise, the poles are to be assumed to be concentrated at points.

2. Magnetic Force or Magnetic Intensity

The magnetic force at a point in a magnetic field is the force in dynes which a unit pole would experience if placed at that point. The direction of the force is the direction in which a unit N -seeking pole would tend to move when placed at that point.

The force due to a pole of strength m at a point distant d cms. in air is

$$\frac{m}{d^2} \text{ dynes}$$

3. Unit Line of Magnetic Force

If there is a uniform magnetic field of unit intensity as defined in § 2, and if a plane surface is drawn perpendicular to the direction of the field, then one unit line of force is said to cross each sq. cm. of the surface.

The magnetic intensity at any point in a field may therefore be defined as the number of unit lines of force per sq. cm. which pass through an element of surface containing the point, and set perpendicular to the direction of the field.

The magnetic intensity is measured in "gauss," that is, a magnetic field of intensity H , as defined above, is said to be of strength H gauss.

4. Flux of Force

If an element of surface of area a sq. cms. be drawn in a magnetic field and perpendicular to the field, and if H is the strength of the field through the surface, the flux of force through the area a is

$$\phi = Ha \text{ unit lines.}$$

5. Unit Pole gives Rise to 4π Unit Lines

Consider a pole of unit strength at the centre of a sphere of 1 cm. radius. Then, according to the definition given in § 3, one unit line of force will cross each sq. cm. of the surface of the sphere. Since the area of the sphere contains 4π sq. cms., the whole number of unit lines which cross the sphere is 4π , that is to say, a unit magnetic pole gives rise to 4π unit lines of force.

6. Intensity of Magnetisation

If a magnetic pole of uniform strength m has an area A sq. cms.

(for example, one surface of the slit in Fig. 3), the intensity of magnetisation is

$$J = \frac{m}{A}$$

An intensity of magnetisation J therefore denotes that the magnetisation gives rise to $4\pi J$ unit lines of force emerging from (or entering into) each sq. cm. of the magnetised surface.

7. Magnetic Force at a Point Inside a Magnetic Material

Suppose a bar of iron, Fig. 1, is placed in a magnetic field. The iron will become magnetised in the direction of the field and magnetic poles will be formed at and near the end surfaces of the bar.

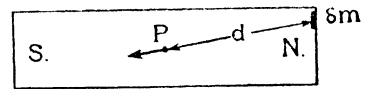

FIG. 1.

Suppose that the strength of the magnetic poles so induced is m per unit area, where m will have different values from point to point on the surface of the poles. Then the actual value of the impressed magnetic force at any point P inside the iron will be *the resultant of the externally impressed field and the force due to the "free" magnetism at the ends of the iron*. The force due to this free magnetism is the resultant of all such quantities as

$$\frac{\delta m}{d^2}$$

taken for the whole of the magnetism on the poles, where δm is an element of free magnetism on the surface of the bar.

The actual resultant intensity of the impressed magnetic field at a point P inside the iron is denoted by H .

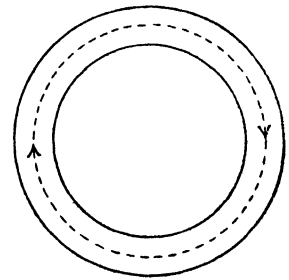

FIG. 2.

If the bar of iron is a closed ring (see Fig. 2), and is magnetised in the direction of its mean circular length, there will be no "free" magnetism at the surface of the iron and the impressed

magnetic force at any point inside the material undergoes no modification due to the magnetism induced in the iron.

8. Magnetic Induction

Suppose that the iron bar of Fig. 1 has an extremely narrow transverse slit (see Fig. 3). Let the actual value of the intensity of the impressed magnetic force be H in the direction perpendicular to the slit. The bar will therefore become magnetised and the induced magnetism will produce lines of force across the slit.

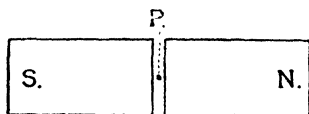

FIG. 3.

If the strength of the induced magnetism on each face of the slit is J , that is to say, is equivalent to J unit magnetic poles per sq. cm. of the surface, the number of magnetic lines which cross the slit will be $4\pi J$, due to this induced magnetism.

Also crossing the slit and superposed on the induced magnetic flux is the impressed field of intensity H gauss.

The total number of magnetic lines crossing each sq. cm. of the slit surface is therefore

$$4\pi J + H$$

If the material of the narrow slit is now replaced, this total number of magnetic lines per sq. cm. will still cross the sectional area of iron at P , and this is called the *magnetic induction density* or simply the *induction*, and is denoted by the letter B , so that

$$B = H + 4\pi J$$

The unit of magnetic flux is the "maxwell," so that if, through a surface of area a sq. cms., the induction is B , the flux across this area will be Ba maxwells.

Writing the above expression in the form

$$B = \mu H,$$

the factor μ is called the magnetic *permeability* of the material.

Therefore

$$\mu H = H + 4\pi J$$

or

$$J = \frac{\mu - 1}{4\pi} H = \kappa H$$

The factor κ is termed the magnetic *susceptibility* of the material.

9. The Magnetic Circuit : Magneto-motive Force

Consider a closed magnetic circuit such as that formed by a closed iron ring as shown in Fig. 4. Suppose that this ring is uniformly wound with an exciting coil having w turns and let a current of I amperes flow through this winding. A magnetic force will be developed in the ring and the lines will be closed circles concentric with the ring. The dotted circle shown in Fig. 4 represents the mean path of these lines of force.

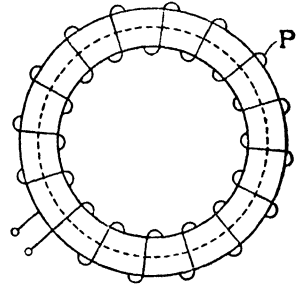

FIG. 4.

Let H gauss be the intensity of the magnetic force at every point along the mean path and let l_m cms. be the length of this mean path. Then the work done in carrying a unit magnetic pole once round the closed circuit will be

$$Hl_m \text{ ergs,}$$

and this quantity is termed the “magneto-motive force” (m.m.f.) round the closed circuit. Now it can be proved that the work done in carrying the unit magnetic pole once round the closed path is also

$$\begin{aligned} &= \frac{4\pi}{10} wI \text{ ergs} \\ &= 1.257wI \text{ ergs} \end{aligned}$$

The factor wI in this expression is the product of the number of turns in the winding and the current in amperes which flows in the winding. This product is called the “ampere-turns” in the winding.

The foregoing expression for the magneto-motive force may be

more generally expressed as follows: *The m.m.f. round any closed circuit is equal to 1.257 times the number of ampere-turns linked with the circuit.*

In the particular case represented in Fig. 4, the magnetic force at every point along the mean magnetic circuit is given by

$$Hl_m = 1.257wI$$

that is

$$H = 1.257 \frac{wI}{l_m} \text{ gauss}$$

But $\frac{wI}{l_m}$ is the number of ampere-turns per cm. length of the mean path, and hence in this particular case

$$H = 1.257 \text{ [ampere-turns per cm. length of the mean path].}$$

The term "gilbert" has been proposed for the unit of magneto-motive force, and this term is commonly used in the United States. The total magneto-motive force round a magnetic circuit may therefore be expressed as

$$1.257 \text{ [ampere-turns] , gilberts.}$$

The m.m.f. of the coil in Fig. 4 carrying a current of I amperes and wound with w_1 turns per cm. of its length is therefore

$$1.257 Iw_1 \text{ , gilberts per cm.}$$

Let B be the induction density along the mean path due to the magnetising force H , then

$$B = \mu H$$

or

$$H = \frac{B}{\mu} = \frac{\phi}{A\mu}$$

where ϕ is the total magnetic flux in the iron, μ the permeability, and A sq. cms. the cross-sectional area.

Hence

$$\text{m.m.f.} = Hl_m = \phi \left(\frac{l_m}{A\mu} \right)$$

From a comparison of this equation with the analogous one for the electric circuit, viz. :

$$\text{e.m.f.} = \text{current} \times \text{resistance,}$$

the quantity

$$\frac{l_m}{A\mu}$$

is termed the *reluctance* of the magnetic circuit, so that the relationship for the magnetic circuit is

$$\text{m.m.f.} = \text{flux} \times \text{reluctance.}$$

The reluctance of any portion of a magnetic circuit of which the length is l_1 cms., the cross-sectional area A_1 sq. cms., and the permeability μ_1 , is

$$\frac{l_1}{A_1\mu_1}$$

10. Self-demagnetising Force of a Magnet

Consider a uniform magnetic field of which the intensity is H gauss. Suppose a bar of iron is introduced into this field and set with its length in the direction of the field. The iron will, of course, become magnetised, the magnetic poles being at the ends of the bar. The effect of these poles will be to produce a magnetic intensity which will be opposed to the original field at points inside the iron. In Fig. 1, for example, the force at P due to the induced magnetism is in the opposite direction to that of the original impressed field.

In the case of a *permanent* magnet removed from the neighbourhood of other magnetic fields, the force due to the poles is the only magnetic force acting. *The permanent magnet exerts a demagnetising force on itself.*

If, however, a ring of iron is magnetised by an electric current as shown in Fig. 4, no magnetic poles will be produced and consequently there will be no self-demagnetising force in this case.

In the case of a magnet shaped as an ellipsoid of revolution, the self-demagnetising force is uniform at all points within the magnet. The magnitude of the self-demagnetising force of such a magnet

can be calculated very accurately. Moreover, when the length of the ellipsoid is great compared with its breadth, the magnitude of the self-demagnetising force becomes small.

Let J be the intensity of magnetisation of the ellipsoid and let H_1 be the intensity of the uniform magnetic field *before* the introduction of the ellipsoid. Since the self-demagnetising force will be uniform throughout the ellipsoid, the actual resultant intensity H will also be uniform throughout the ellipsoid. The self-demagnetising force will be

$$H_1 - H$$

and since this self-demagnetising force is due to the intensity of magnetisation J , the following relationship holds, viz. :

$$H_1 - H = YJ,$$

where Y is termed the *self-demagnetising coefficient*.

For an ellipsoid of revolution of length (*i.e.*, major axis) a and breadth (*i.e.*, minor axis) b , the self-demagnetising coefficient is

$$Y = 4\pi \left(\frac{1}{r^2} - 1 \right) \left(\frac{1}{2r} \log_e \frac{1+r}{1-r} - 1 \right)$$

where

$$r = \sqrt{1 - \frac{b^2}{a^2}}$$

For an ellipsoid of revolution in which the length a is great compared with the breadth b , it may be shown that

$$Y = 4\pi \frac{b^2}{a^2} \left(\log_e \frac{2a}{b} - 1 \right)$$

For example, if $a = 150b$,

$$Y = 4\pi \times \frac{44.5}{10^6} \times 4.7$$

that is,

$$Y = 0.00264.$$

The self-demagnetising force would therefore be

$$H_1 - H = 0.00264J.$$

Hence, if $J = 1700$, which is about the highest value the intensity

of magnetisation can have for pure iron (see Chapters II, § 20; IV, § 34), the self-demagnetising force will be only 4.5 gauss.

If $a = 400 b$, the self-demagnetising force will be

$$H_1 - H = 0.00045J.$$

so that for $J = 1700$ the self-demagnetising force now becomes 0.76 gauss.

In testing the magnetic properties of materials, specimens in the form of an elongated ellipsoid of revolution would therefore be very suitable. From a practical point of view, however, it is not very easy to prepare the specimens in this form. Experiment shows that if the specimen is in the form of a long thin rod, the self-demagnetising force is small.

The following Table gives the value of the coefficient of self-demagnetisation Y for cylindrical rods for various values of the ratio of length to diameter.

TABLE
VALUES OF THE COEFFICIENT OF SELF-DEMAGNETISATION Y FOR LONG
CYLINDRICAL RODS.

Ratio : $\left(\frac{\text{Length}}{\text{Diameter}}\right)$	Y
50	0.01820
100	0.00515
200	0.00148
300	0.00070
500	0.00027

11. Paramagnetic and Diamagnetic Substances

Most substances are acted on by a magnetic field and can be arranged in two distinct classes according to the nature of their action when placed in a magnetic field. In one class are substances whose axis of magnetisation is in the same direction as the magnetising force and in the other class are substances such as bismuth, whose magnetisation acts directly opposite to the magnetising force.

{ Substances which become magnetised in the same direction

as the magnetising force are termed *paramagnetic* and substances which become magnetised in the opposite direction to the magnetising force are termed *diamagnetic*.

Iron, steel, cobalt, nickel, etc., which are capable of a high degree of magnetisation, are termed *ferromagnetic* substances.

Apart from the ferromagnetic group, the most powerfully paramagnetic substance is neodymium, the permeability of which

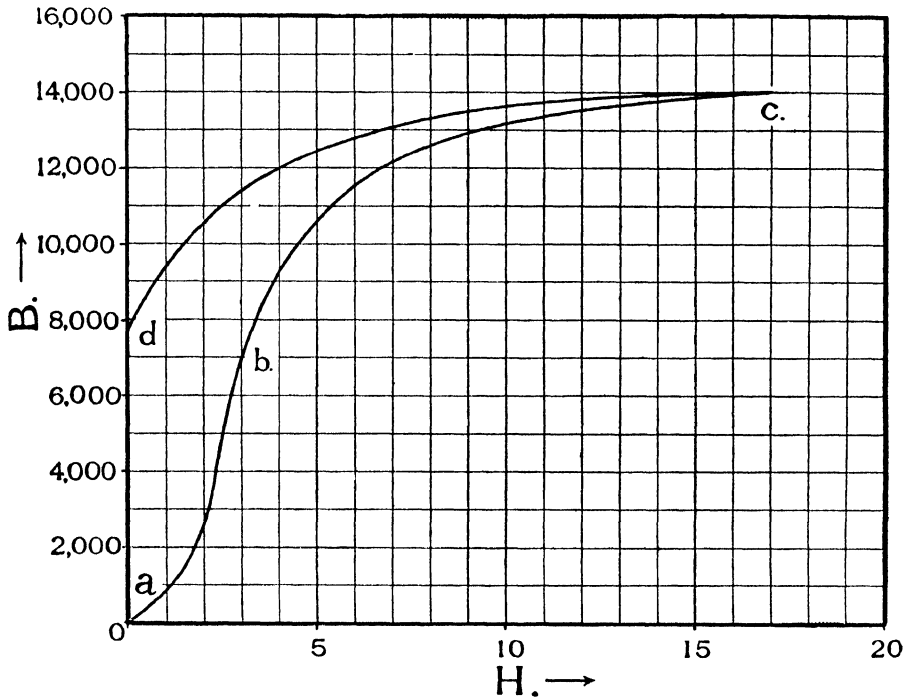

FIG. 5.

is $\mu = 1.003$. Amongst other substances, oxygen and manganese are interesting examples of paramagnetic substances.

The metal bismuth which is strongly diamagnetic has a permeability $\mu = 0.99983$. This corresponds to a negative susceptibility $\kappa = -0.0000136$.

12. The Magnetisation Curve and Hysteresis Loop

Suppose a ring of mild steel is wound uniformly with a magnetising

coil of wire as shown at P in Fig. 4. Let the iron ring be first completely demagnetised as follows: An alternating current of, say, 50 frequency is passed through the magnetising coil, P , having such a strength that the iron becomes magnetised to saturation. The current is then gradually reduced in strength by means of a resistance in series with the coil P or, alternatively, by reducing the field strength of the alternator. After the current has been reduced to as low a value as possible in this way, the alternator is shut down and when it has completely come to rest, the coil P is disconnected. In this way the iron will have become thoroughly demagnetised.

If a small value of direct current be now passed through the exciting coil the curve connecting the magnetic induction B and the magnetic force H will take some such shape as Oa in Fig. 5, that is, the values of B will increase at a moderate rate as the values of H increase.

When the value of the magnetising force H has reached the value of one or two gauss, the curve rises much more rapidly as shown at ab . For high values of H the curve bends back towards the H axis as shown at bc .

The connection between B and H shown by the curve abc is the *magnetisation curve* of the iron.

If, after reaching some such value of the magnetising force as specified by the point c , the magnetising force is then completely removed, say, by opening the circuit of the magnetising coil P , the iron retains an amount of magnetisation represented by Od . This is termed the *remanent magnetism* or *remanence*.

Since

$$B = 4\pi J + H,$$

and since for the point d the value of H is zero, it follows that the remanent induction B_{rem} is equal to 4π times the remanent intensity of magnetisation J_{rem} . That is,

$$B_{rem} = 4\pi J_{rem}$$

Now referring to Fig. 6, in which Ocd represents another magnetisation curve and Og the remanent induction. Suppose that,

after having been reduced to zero, the magnetising force is given a gradually increasing *negative* value. The corresponding values of the induction B will be given by the curve gh , so that when B becomes zero, H has the negative value Oh . This value of H which is necessary to reduce the induction in the iron to zero is termed the *coercive force*.

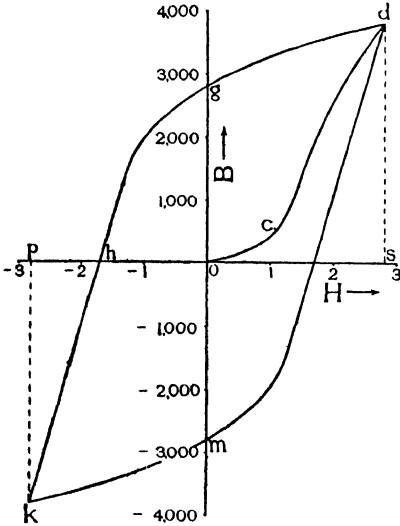

FIG. 6

As H is still further increased in the negative direction, B becomes negative and the curve hk is obtained such that, when the negative value of H , viz. Op , is the same as the maximum positive value of H , viz. Os , the maximum negative value of B is equal to the maximum positive value of B , that is, $sd = pk$.

If the negative value of H be now reduced to zero, the curve km is obtained, so that when H is zero, the induction has the negative value Om equal to Og .

When H is increased in the positive direction, the curve md is obtained, so that when H again reaches its former maximum positive value, the induction B also attains its former maximum value. In this way a closed loop $dghkmd$ is obtained, and is known as the *hysteresis loop*.

It may be observed here that, strictly speaking, the relationships detailed in the foregoing, viz. that $sd = pk$ when $Os = Op$, and that a closed loop will be obtained, only hold after the iron has been brought into the cyclic state by passing several times through the magnetic condition represented by the loop $dghkmd$.

The area of the hysteresis loop represents a definite amount of energy lost in performing the magnetic cycle and this loss is termed the *hysteresis loss*. The energy represented by the area of the hysteresis loop is dissipated in heat.

13. The Energy Stored in a Magnetic Field

If a current of I amperes flows in a coil of w turns (see Fig. 4), and if, in consequence, ϕ unit magnetic lines link the coil, the flux linkages per ampere will be

$$\frac{\phi w}{I}$$

The number of flux linkages per ampere divided by 10^8 is termed the *inductance* L of the coil in henrys, that is,

$$L = \frac{\phi w}{I10^8} \text{ henrys,}$$

or, the flux linkages are

$$\phi w = LI10^8$$

It can be shown (see below) that the total work done in establishing the current I amperes in the coil is

$$\frac{1}{2}LI^2 \text{ joules,}$$

and this is the energy stored in the magnetic field.

The above result holds if the inductance L is constant throughout the range of flux considered, that is, if the flux is strictly proportional to the current.

If there is iron in the magnetic circuit, it is necessary to know the shape of the magnetisation curve before the energy stored in the magnetic field can be determined.

Suppose the corresponding values of B and H for a uniformly magnetised iron ring are as shown in Fig. 7. The energy expended in producing the flux in the ring is

$$\int e i dt \text{ joules,}$$

where e volts is the back e.m.f. induced in the magnetising coil by the changing flux, and i amperes is the corresponding current in the coil at the moment t . The integration is taken over the whole time required to establish the flux in the ring.

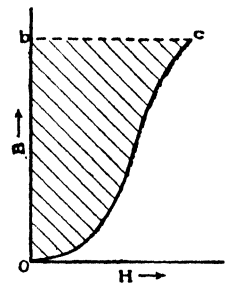

FIG. 7.

The energy absorbed in establishing the current is therefore

$$\frac{1}{10^8} \int \frac{d(BAw)}{dt} idt \text{ joules}$$

since

$$e = \frac{d BAw}{dt} \frac{1}{10^8} \text{ volts}$$

where w is the number of turns in the exciting coil.

If the iron is magnetised to an induction $B(=Ob, \text{ Fig. 7})$, the energy stored in the magnetic field will be

$$\begin{aligned} & \frac{1}{4\pi \times 10^7} \int_0^B Hl_m A dB \text{ joules} \\ &= \frac{1}{4\pi} \int_0^B H dB \text{ ergs per c.c. of the iron.} \end{aligned}$$

since

$$\frac{4\pi}{10} iw = Hl_m$$

and l_m cms. is the length of the mean magnetic circuit.

Since one erg is equal to 0.737×10^{-7} ft.-lb., the energy stored in the magnetic field when the iron is magnetised to the induction $Ob, \text{ Fig. 7}$, is

(shaded area) $\times \frac{0.737}{4\pi \times 10^7}$ ft.-lb. per c.c. of the iron (see also Chapter XV, § 82).

If the substance in which the magnetic field is established is non-magnetic, the relationship between B and H will be given by the straight line $Oc, \text{ Fig. 8}$.

The energy stored in the magnetic field when the induction is $B(=Ob)$, and the corresponding magnetising force is $H(=Oc)$, is

$$\begin{aligned} &= \frac{1}{4\pi} \times (\text{shaded area}) \\ &= \frac{1}{4\pi} \times \frac{1}{2} BH \\ &= \frac{1}{8\pi} BH \text{ ergs per c.c.} \end{aligned}$$

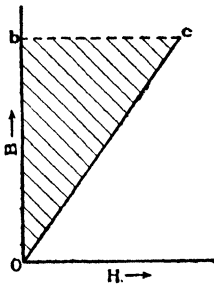

FIG. 8.

But for non-magnetic substances, the permeability $\mu = 1$, that is, $B = H$. Hence the stored energy of the magnetic field is

$$= \frac{1}{8\pi} H^2 \text{ ergs per c.c.}$$

The maximum value of H practically obtainable by normal means (*e.g.*, electro-magnet) is about 25,000 gauss. The maximum amount of energy which it is practicable to store in a magnetic field in non-magnetic materials is therefore

$$\begin{aligned} \frac{H^2}{8\pi} &= \frac{(25,000)^2}{8\pi} = 24.8 \times 10^6 \text{ ergs per c.c.} \\ &= 30 \text{ ft.-lb. per cubic inch.} \end{aligned}$$

Recently, the author has succeeded in obtaining very intense magnetic fields (see Chapter VII), *viz.*, of the order of half a million gauss. For a field of intensity of 500,000 gauss the energy stored in the magnetic field is

$$\begin{aligned} &= 9,900 \times 10^6 \text{ ergs per c.c.} \\ &= 12,000 \text{ ft.-lb. per cubic inch.} \end{aligned}$$

If the air-space which is occupied by the uniform magnetic field is of cross-section A_g sq. cms. (that is, the section at right angles to the direction of the field), and length l_g cms., the total energy stored in the magnetic field in the whole of the air-space considered is

$$\begin{aligned} &\frac{1}{8\pi} BHA_g l_g \text{ ergs,} \\ &\frac{1}{8\pi} \phi V_g \text{ ergs,} \end{aligned}$$

where $\phi = BA_g$ and is the total magnetic flux through the air-space, and

$$V_g = Hl_g \text{ ergs.}$$

Since the quantity Hl_g is the work which would be done in carrying a unit pole the distance l_g along the air-space, this quantity is the magnetic potential across the air-space and is denoted by V_g in the foregoing expression.

14. Pull between Two Magnetised Iron Surfaces

In Fig. 9 are shown two magnetised iron surfaces separated by a gap of δ cms.

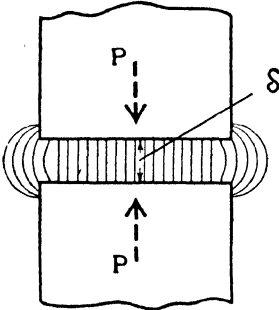

FIG. 9.

If the magnetic induction in the gap is assumed to be uniform and equal to B and if the surface area of each magnetised face is A sq. cms., then the magnetic energy which is stored in the gap will be (§ 13),

$$\frac{B^2}{8\pi} A\delta \text{ ergs.}$$

Let P be the pull in dynes which acts on each gap surface due to the magnetic field. Suppose the length of the gap is increased by an extremely small amount so that the new

gap is δ_1 cms. long.

The increase of energy stored in the magnetic field will be

$$\begin{aligned} &= \left[\frac{B^2}{8\pi} A\delta_1 - \frac{B^2}{8\pi} A\delta \right] \text{ ergs} \\ &= \frac{B^2}{8\pi} A(\delta_1 - \delta). \end{aligned}$$

Hence the work done in increasing the length of the gap from δ cms. to δ_1 cms. is

$$P(\delta_1 - \delta) = \frac{B^2}{8\pi} A(\delta_1 - \delta),$$

that is, the pull is

$$P = \frac{B^2}{8\pi} A \text{ dynes,}$$

or

$$P = 0.09 \left(\frac{B}{1000} \right)^2 A \text{ lb. weight}$$

This formula enables the strength of the magnetic field to be calculated which is necessary to support a given load.

An early form of permeameter (S. P. Thompson's) was based on the relationship between induction density and magnetic pull as expressed by this formula.

In deducing the formula for the magnetic pull, it has been assumed that the induction density is uniform throughout the gap. This is approximately true if the gap length δ is very small compared with the gap area A .

If δ is not small, the lines of force will bulge outwards at places near the edges of the gap and an accurate calculation of the pull can then be made only by dividing the whole magnetic field into small elements such that the value of B may be taken to be constant for any one element. The total pull is then obtained as the sum of the pulls due to the individual elements.

15. Energy Loss Due to Hysteresis

As the result of a large number of tests, Steinmetz found that the hysteresis loss per cycle, that is,

$$\frac{1}{4\pi} \text{ (area of the hysteresis loop),}$$

is closely proportional to the 1.6th power of the maximum induction density reached during the cycle, for example, the induction corresponding to the tip d of the loop in Fig. 6 (see also Chapter XIV, and Chapter XV, § 82).

This relationship holds over a wide range of induction densities, viz. from about $B_{\max.} = 1,000$ to $B_{\max.} = 13,000$.

The energy loss due to hysteresis may therefore be written :

$$\begin{aligned} U_h &= \eta B_{\max.}^{1.6} \text{ ergs per c.c. per cycle} \\ &= \eta B_{\max.}^{1.6} \times 10^{-7} \text{ joules per c.c. per cycle} \\ &= 58\eta B_{\max.}^{1.6} \times 10^{-7} \text{ joules per lb. per cycle.} \end{aligned}$$

The factor η is known as the hysteresis constant of the iron and its value depends on the quality of the iron.

For good armature iron, the value of η may be taken to be 0.0013, and assuming this value for η , Fig. 10 has been drawn showing the hysteresis loss in joules per lb. per cycle as a function of B .

For values of B_{\max} less than about 500 the hysteresis loss per cycle may be taken to be closely proportional to B_{\max}^2 .

Some experiments carried out in the United States* have shown that for iron, iron-silicon alloys, and iron-aluminium alloys, melted *in vacuo* in an electric furnace, extraordinarily low values for the hysteresis loss have been obtained.

For electrolytic iron with a trace of carbon, the hysteresis loss

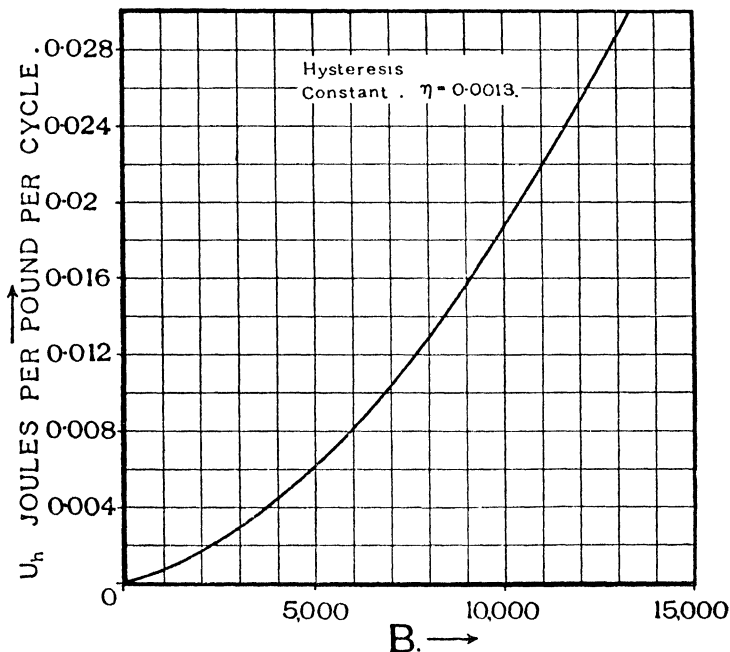

FIG. 10.

for $B_{\max} = 10,000$ was found to be 813 ergs per c.c. per cycle. This corresponds to the value $\eta = 0.00032$ for the hysteresis constant.

For iron with no carbon but with 3.4% of silicon, the hysteresis loss for $B_{\max} = 10,000$ was about 300 ergs per c.c. per cycle. This gives a value of $\eta = 0.00012$ for the hysteresis constant.

For iron with 0.4% aluminium annealed at 1100° C. the hysteresis loss for $B_{\max} = 10,000$ was 450 ergs per c.c. per cycle, so that the hysteresis constant is $\eta = 0.00018$.

See Yensen, *Bulletin of Bureau of Standards*.

TABLE

REPRESENTATIVE VALUES FOR THE HYSTERETIC CONSTANT η FOR THE MORE IMPORTANT MAGNETIC MATERIALS

Material.	Hysteretic Constant η .
Good Armature Iron Stampings	0.0013
Silicon Iron ("Stalloy")	0.00085
Iron melted <i>in vacuo</i> and containing a small percentage of carbon	0.0003
Iron melted <i>in vacuo</i> and containing a small percentage of silicon	0.0001
Cast Iron	0.008 to 0.020
Tungsten Magnet Steel	0.052
Carbon Magnet Steel	0.045
Cast Cobalt	0.010 to 0.020
Magnetite	0.023
Heusler Alloy	0.003 to 0.030
Nickel	0.020 to 0.025

16. Hysteresis Loss in an Unsymmetrical Cycle

The hysteresis loops previously considered have been unsymmetrical loops, that is to say, those in which the upper limit of the magnetic induction is equal and of opposite sign to the lower limit of induction. Otherwise stated, symmetrical hysteresis loops are those traced out between the limits $\pm B$.

Now consider an unsymmetrical loop such as that shown in Fig. 11, where the cycle is carried out between the limits

$$+ B_1 \text{ and } + B_2.$$

Let

$$B_m = \frac{B_1 + B_2}{2}$$

and

$$B = \frac{B_1 - B_2}{2}.$$

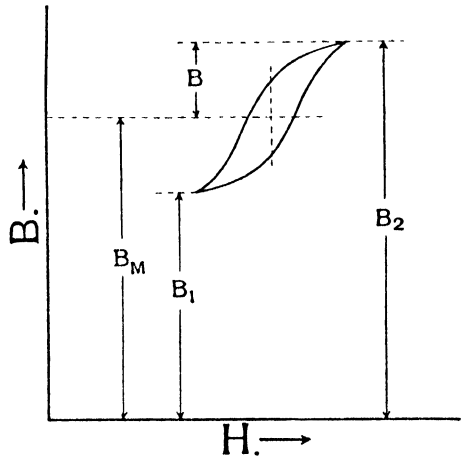

The hysteresis loss for such a loop is given by the expression

$$U = \eta_\mu B_m^{1.6}$$

The hysteresis factor η_μ is constant so long as the mean value of the induction B_m is constant. If the mean value B_m is not constant, then the factor η_μ is given by the relationship

$$\eta_\mu = \eta + \alpha B_m^{1.9},$$

where η is the hysteresis constant for a symmetrical cycle.

For good ordinary sheet steel,

$$\eta = 0.0012, \text{ and } \alpha = 0.344 \times 10^{-10}$$

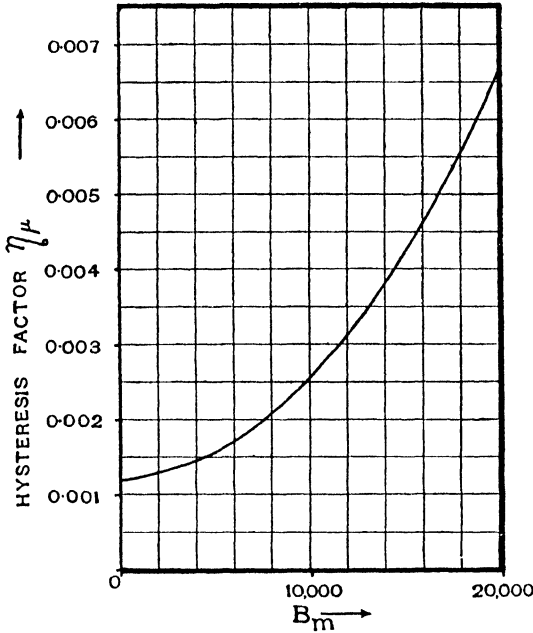

FIG. 12.

In Fig. 12 the values of η_μ are plotted as a function of B_m . It will be seen from Fig. 12 that if the cycle is not very unsymmetrical, that is, if B_m is small, say $B_1 = + 10,000$, $B_2 = - 6,000$, $B_m = 2,000$, the value of η_μ is not very different from η , and the loss in the unsymmetrical cycle is not

much greater than in a symmetrical cycle of the same amplitude.

For more unsymmetrical cycles, however, such, for example, as

$$B_1 = + 10,000, B_2 = + 6,000, B_m = 8,000,$$

the hysteresis loss becomes very much larger than in a symmetrical cycle of the same amplitude ($B_m = 2,000$).

Practical examples of unsymmetrical cycles are found in a great variety of machines and apparatus. For example, in the pole-shoes of direct current machines, where the steady flux of the field has

impressed on it the small hysteresis loops due to the flux pulsations as the armature slots and teeth sweep across the pole surface. In the iron cores of the transformers of a mercury arc rectifier, unsymmetrical hysteresis cycles are produced. The iron core of a telephone receiver is subjected to unsymmetrical hysteresis cycles due to the alternating current magnetisation superimposed on the permanent magnet field.

17. Hysteresis in Very Weak Fields

Baur carried out some tests on a ring of soft iron when subjected to very small values of the impressed force. He found that for values of H up to about 0.4 gauss, the relationship between B and H could be expressed by the equation

$$B = 183H + 1382H^2$$

and hence the permeability

$$\mu = \frac{B}{H} = 183 + 1382H$$

This result implies that for very small values of H the permeability should be very approximately constant and equal to 183. Lord Rayleigh carried out some tests on unannealed Swedish iron wire and found that when H was less than 0.04, the permeability was constant and equal to about 100. It follows, therefore, that for values of H below about 0.04, the magnetisation curve of this quality of iron was a straight line, and consequently there was no remanent magnetism and no hysteresis loss (see also Fig. 50, Chapter IV).

18. Ewing's Molecular Theory of Magnetism

The fundamental facts of magnetism may be accounted for in a satisfactory manner on the assumption that the molecules of iron and steel are permanent magnets capable of being turned round their centres. This hypothesis was first developed by Weber, and, briefly stated, the conception is as follows :

In an unmagnetised bar of iron or steel the molecular magnets are so irregularly arranged that they mutually neutralise each other's external field. When the bar is subject to a magnetising

force some of the molecules are turned so that their magnetic axes lie in the direction of the force. As the intensity of the magnetising force increases, more and more molecules set in the direction of the force, and the bar becomes correspondingly more strongly magnetised. There is, however, a limit to the magnetisation of the bar, and this limit is reached when all the molecules are arranged in the direction of the magnetising force when the iron is said to be *saturated*. This statement of the theory accounts for the observed facts to a certain extent, but it does not account for the fact that there is some internal constraint in the iron which prevents all the molecular magnets coming into line with the magnetising force until this force has reached a high value. The theory also does not account for the internal constraint which maintains the remanent magnetism when the magnetising force is reduced to zero—in other words, the phenomenon of **hysteresis** is not explained.

Ewing, as the result of his experiments, has developed the theory, and accounts for the constraint as being due to the mutual magnetic action between the molecular magnets as follows :

When a piece of iron is unmagnetised, the molecules are arranged in groups, each group forming a stable magnetic system and producing no external magnetic action. When such a group is subject to a small magnetising force H , each member of the group becomes slightly deflected, but the group still maintains its general formation. When the small magnetising force is removed, each member returns to its original position and the external action of the group disappears. These results correspond to the initial stage *oa* of the magnetisation curve in Fig. 5. For this first stage the magnetic induction is very nearly proportional to the magnetising force, and there is no appreciable hysteresis loss when the magnetisation is carried through a cycle of which the maximum value of the induction density is within the limits of this first stage, because the hysteresis loop shrinks to a straight line. Moreover, during this first stage the rate of increase of B with H is relatively small.

If the magnetising force H is now still further increased, the second stage of magnetisation is reached. The individual com-

ponents of each group of molecules become still further deflected, and this increased deflection is sufficient to break up some of the groups. The molecules of these ruptured groups then rearrange themselves under the magnetic forces, and form new groups in which the molecular magnets are more nearly in line with the magnetising force. As H continues to increase, more groups are broken up in this way, and the part of the magnetisation curve ab (Fig. 5) is obtained in which B increases rapidly with H . This action continues until the condition of *saturation* is approached, the molecules become arranged in their final grouping, and the third stage of magnetisation is reached.

Still further increase of H causes the molecular magnets of the new groups to set more and more completely in line with the force until eventually the molecular magnets are all arranged in line with the magnetising force, and the iron is *saturated*. This stage about corresponds to that part of the curve $abcd$ in Fig. 5 to the right of the ordinate $H = 10$.

Now

$$B = 4\pi J + H,$$

and when saturation is reached, J has attained its maximum value, and the expression becomes—

$$B = \text{constant} + H.$$

The maximum value of J for pure iron is about 1680, so that for values of H corresponding to saturation values

$$B = 4\pi \times 1680 + H = 21,000 + H.$$

It is to be observed that these three stages are not sharply defined, but that the consecutive stages gradually merge into each other, there being a range over which the phenomena of both stages 1 and 2 act, and a range over which the phenomena of both stages 2 and 3 act.

If after reaching saturation, the magnetic force is gradually reduced, the magnetisation curve will coincide with the original curve in so far as the reduction of H corresponds to a change in deflection of the individual molecules of a group, but not to the rupture of a group.

As the magnetising force is still further reduced the molecular groups begin to rupture, but owing to the forces between the components of the group there is a constraint which prevents the magnetism of the iron being reduced proportionally to the reduction of the magnetising force, so that when H is reduced to zero there is a considerable amount of residual magnetism in the iron corresponding to the point d in Fig. 5. In other words, the magnetic induction *lags* behind the magnetising force, so that an increase or a decrease of H is not accompanied by a proportional increase or decrease of B , and this is known as the *hysteresis* effect. If it be assumed that mechanical vibration of the iron results in a greater freedom of movement of the molecules, the fact that such mechanical vibration reduces the amount of remanent magnetism is also accounted for, and similarly the fact that a given magnetising force produces a greater degree of magnetisation in a bar which is being hammered than one which is not so treated.

The hysteresis effect entails a loss of energy dissipated in heat, because when each molecular group is ruptured the individual members are set vibrating, the corresponding kinetic energy being eventually transformed into heat.

In Ewing's experiments all these effects were exhibited by means of a model, in which a number of small compass needles were pivoted on a fixed base and were intended to represent the molecular magnets of a piece of iron (see "Magnetic Induction in Iron and Other Metals," J. A. Ewing).

A very interesting consequence of Ewing's theory of magnetic hysteresis was foretold by Swinburne soon after the account of this theory had been published. Swinburne argued that if iron were rotated in a very strong magnetic field, the molecular magnets being held in line by the magnetising force throughout the cycle, there would be no dissipation of energy due to the rupturing of groups of molecular magnets and, in consequence, the hysteresis effect would disappear. This remarkable prediction has been since verified by experiment and in Fig. 13 is shown the hysteresis loss in sheet iron due to rotation in fields of various strengths. It will

be noticed that in this particular case the hysteresis loss reaches a maximum when the field strength is about 16,000 lines per sq. cm. As the field strength is further increased the hysteresis loss decreases and becomes zero when the field strength is about 25,000 lines per sq. cm.*

Recently, Ewing has modified the original form of his theory.† It was earlier supposed that the molecules themselves constituted the elementary magnets which, when oriented under the impressed magnetic force, gave rise to the magnetic characteristic of the iron.

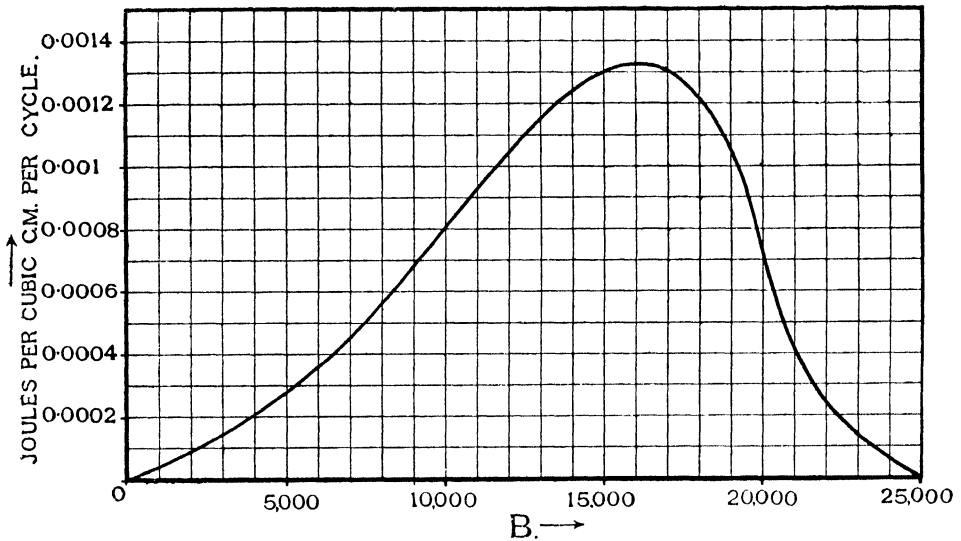

FIG. 13.

As explained in Chapter VII, however, it is now held that it is the revolving electrons within the atom which give rise to the magnetic properties and that it is not the atom as a whole which becomes oriented, but something within the atom.

From considerations of the limits of reversibility, that is, the range of values of the magnetising force for which the hysteresis is zero, Ewing concludes that his original model is not satisfactory

See Beattie and Clinker, *Electrician*, Vol. XXXVII, p. 723.

See *Proc. Royal Society*, Feb., 1922; *Phil. Mag.*, March, 1922.

and he has devised a new model based on the movement of the electronic rings within the atom.

19. Evershed's Theory of Magnetism Based on the Ampère-Ewing Theory

As will be seen in Chapter VII, no new "magnetic medium" enters into consideration when dealing with magnetic substances. On the contrary, the view is now held that each atom of the magnetic substance itself comprises a number of current rings and these current rings give rise to corresponding magnetic fields within the atoms. The medium or space in which these magnetic fields

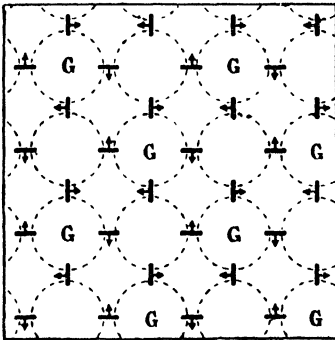

FIG. 14.

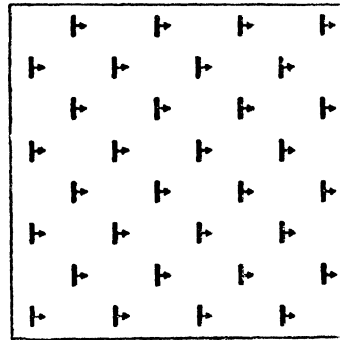

FIG. 15

are established is the universal "ether" and is in no way different from the space outside the magnet.

The following brief statement is abstracted from S. Evershed's paper* and is based on the Ampère-Ewing theory.

In the case of pure annealed iron it is considered that the current rings are approximately evenly spaced throughout the mass of the iron. In the unmagnetised state, the current rings will arrange themselves in stable equilibrium so that their magnetic fields form small closed circuits and thus no magnetic effect becomes evident outside the substance. This is shown diagrammatically in Fig. 14 which is a plan of a cubical grouping of current rings arranged about the centres GG .

* See *Journal of the Institution of Electrical Engineers*, 1920, Vol. LVIII, p. 78

When, say, a horizontal magnetising force is impressed on the substance, the stable grouping in Fig. 14 will resist the tendency of the applied force to orient the individual current rings so that their axes will point in the direction of the impressed force, this resistance being due to the torque which is exerted on any one current ring by the other members of the self-contained group to which it belongs. As the intensity of the applied magnetising force increases, it will eventually exceed the opposing torque due to the stable grouping, Fig. 14, and the current rings will then all swing round and set themselves with their magnetic axes in line with the applied force as shown in Fig. 15. In this now completely oriented

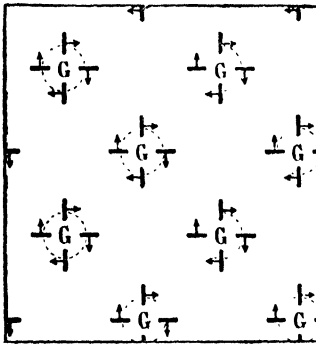

H=0
Fig. 16.

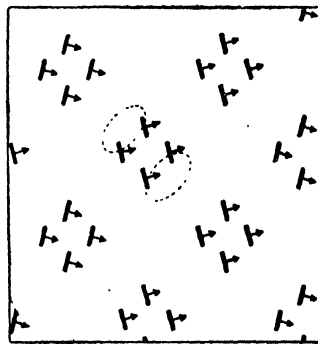

H
Fig. 17.

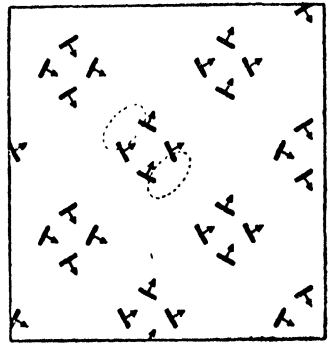

H=0
Fig. 18.

state, the mass of current rings will be in equilibrium and will remain in equilibrium when the applied force is removed. The whole assembly of current rings will thus pass from the condition of equilibrium of Fig. 14 to the condition of equilibrium of Fig. 15, by passing through a stage of inequilibrium.

With the assumed distribution shown in Figs. 14 and 15, therefore, the substance would show a remanent magnetism equal to the saturation value. In practice, however, no substance is known which behaves in this way, the remanent magnetism always being very much less than the saturation value.

In substances like steel, which have a definite crystalline structure, the atomic current rings are considered as being concentrated into

compact groups with relatively large spaces between neighbouring groups, as shown in Fig. 16. The distribution shown in Fig. 16 does not imply any change in the average number of current rings in unit volume, but merely that each group of current rings shown in Fig. 14 shrinks into each group shown in Fig. 16, which represents the completely unmagnetised condition of the substance.

When a strong magnetising force H is applied to the substance, each group of current rings will re-arrange itself somewhat as shown

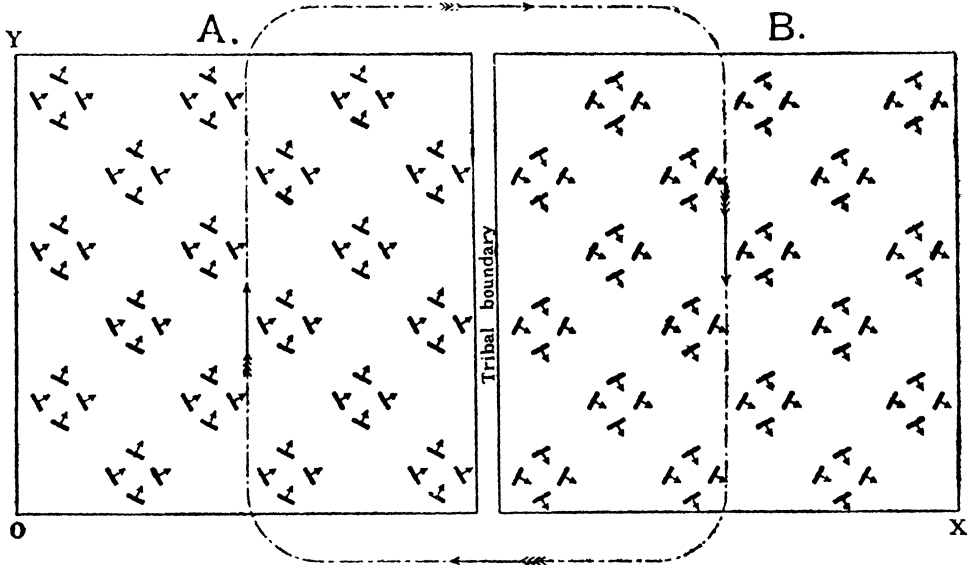

FIG. 19.

in Fig. 17, so that the magnetic axes of the individual groups all have components in the direction of the applied force H . After the removal of the magnetising force the current rings will return to some such stable arrangement as shown in Fig. 18, and this remanent arrangement of the current rings accounts for the remanent magnetism.

It is assumed that each crystal of steel comprises a large number of groups of current rings so that each of the systems shown in the respective Figs. 16, 17, and 18 may be considered as a portion of a crystal.

In Figs. 17 and 18 the magnetic axes of the individual current ring groups are shown as pointing in directions equally inclined above and below the horizontal axis. Such an arrangement, however, would not be stable and considerations of the condition of maximum energy lead to the conclusion that the groups in each crystal will all be arranged so that their magnetic axes point in directions which are either all above or all below the horizontal axis as shown in Figs. 19A and B. The diagrammatical representation given in Fig. 19 is intended to represent the grouping in adjacent crystals of the steel.

For the further development of this interesting theory of the magnetic constitution of steel, the reader is referred to Evershed's original paper (see also Chapters II and VII).

CHAPTER II

THEORY OF PERMANENT MAGNETS

20. The Inherent Magneto-motive Force of a Magnetic Substance

IN accordance with the electron theory of magnetism, each atom of iron, steel, and other highly magnetic substance is assumed to comprise a number of current rings which may be replaced by a single equivalent current ring, as explained in greater detail in Chapter VII.*

The whole mass of the substance thus comprises an assembly of minute current rings. In the unmagnetised state of the substance, these current rings are arranged in small stable groups in each of which the magnetic lines of force due to the current rings are closed on themselves within the limits of the group so that no magnetic effect becomes observable outside the limits of the group.

When subjected to an externally applied magnetic force, the current rings become oriented so that their magnetic axes set themselves more or less in the same direction and the magnetic field due to the current rings becomes evident outside the mass of the material—in other words, the substance becomes “magnetised.”

A magnetic substance thus possesses an inherent magneto-motive force and this can be expressed in the usual form as follows :

The magneto-motive force round any closed path is equal to

$$\frac{4\pi}{10} \text{ [ampere-turns linked with that path]}$$

In this case, “the ampere-turns linked with the path” are the number of atomic current rings linked with the path, it being assumed, of course, that the current rings linked all have their axes (or a component of the axis) directed the same way. That is to say, no current ring has its magnetic effect directly opposed to that of the other current rings.

* See also S. Evershed, *Journal of the Institution of Electrical Engineers*, 1920, Vol. LVIII, p. 780.

Assuming there to be one current ring per atom and N_a such rings per c.c. of the material.

Further, let i amperes be the strength of the current in each current ring.

When the substance is magnetised to saturation, that is to say, when all the current rings have turned so that their magnetic axes are all lying in the direction of the magnetising force H , the magnetomotive force due to the current rings will be

$$\frac{4\pi}{10} i \left[\begin{array}{l} \text{Number of the current rings threaded by a line} \\ \text{drawn parallel to the magnetising force } H \end{array} \right]$$

Let s sq. cms. be the area of each current ring. Then if there are N_a current rings per c.c., the average number of rings in 1 sq. cm. of cross-section perpendicular to H will be $\frac{1}{s}$ and the average number of current rings per cm. length in the direction of H will be

$$\frac{N_a}{1} = sN_a$$

Hence the average number of current rings threaded per cm. length by any line drawn parallel to the direction of the magnetising force H will be

$$sN_a$$

It follows, therefore, that the inherent m.m.f. of the substance is

$$\frac{4\pi}{10} isN_a \text{ per cm. length}$$

If the substance is not magnetised to saturation, that is, if the current rings are not all oriented so that their magnetic axes coincide with the direction of the applied force H , it may be assumed that the planes of the rings make an average angle θ with the direction of H and hence the m.m.f. of the current rings per cm. length of the magnetised substance will be

$$\frac{4\pi}{10} isN_a \sin \theta$$

Now for pure iron it is known that when magnetised to saturation, the flux density due to the magnetisation of the iron is about 21,500 lines per sq. cm. That is to say, the maximum value of the intensity of magnetisation J_s is given by the relationship

$$4\pi J_s = 21,500$$

or

$$J_s = 1,700 \text{ approximately}$$

But this flux density of 21,500 lines per sq. cm. is due to the m.m.f. of the fully oriented current rings, so that the m.m.f. of the fully oriented current rings per cm. length of the magnetised substance is equal to 21,500.

Hence

$$\frac{4\pi}{10} isN_a = 21,500,$$

or

$$isN_a = 17,000 \text{ approximately};$$

that is, the ampere-turns of the current rings per cm. length of the magnetised substance is about 17,000.

This result shows what enormously large values of the m.m.f. are produced by the currents in the atoms of the substance itself.

Now let

x be the number of electrons revolving within each atom,
 e be the charge of each electron in coulombs,
 n be the number of revolutions per second of the electrons,
 i amperes be the value of the current per atom due to the revolving electrons,

then

$$i = xen^*$$

therefore

$$xensN_a = 17,000$$

where s sq. cms. is the area of a current ring, and N is the number

* This assumes that all the electrons are revolving in the same direction within the atom, which is probably not true.

of current rings, that is, the number of atoms, per c.c. of the material as before.

Taking the following numerical values, viz. :

$$N_a = 74 \times 10^{21}$$

$$e = 1.6 \times 10^{-19}$$

$x = 26$, that is, the "atomic number" for iron,

$$s = 7.5 \times 10^{-18} \text{ sq. cm. as the average area of the current rings,}$$

then

$$n = \frac{17,000}{xesN_a} = 7 \times 10^{15} \text{ revs. per second}$$

This result may be compared with the data given in Chapter VII.

If the magnetised substance is a closed ring and is magnetised in the direction of the mean circumference, the m.m.f. of the oriented current rings accounts for the remanent magnetism and this m.m.f. is wholly expended in driving the magnetic flux round the iron ring.

If the iron ring were to be cut across a radius so that an air-gap were included in the magnetic circuit, the m.m.f. due to the oriented current rings would then have to drive the flux through the iron and also across the air-gap.

21. Energy Stored in the Air-space of a Permanent Magnet

In Fig. 20 is shown a ring form of permanent magnet of uniform cross-section, there being an air-gap AC of length l_g cms. in the magnetic circuit.

Suppose the flux density is taken to be uniform throughout the air-gap AC and of value B_g lines per sq. cm.

Further, let A_g sq. cms. be the cross-sectional area of the gap.

The energy stored in the magnetic field in the air-gap is

$$\frac{B_g^2}{8\pi} \text{ ergs per c.c.}$$

as shown in § 13.

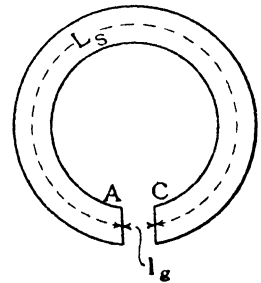

FIG. 20.

The volume of the air-gap is

$$A_g l_g \text{ c.c.}$$

Hence the total energy stored in the magnetic field in the air-gap is

$$\frac{B_g^2}{8\pi} A_g l_g \text{ ergs}$$

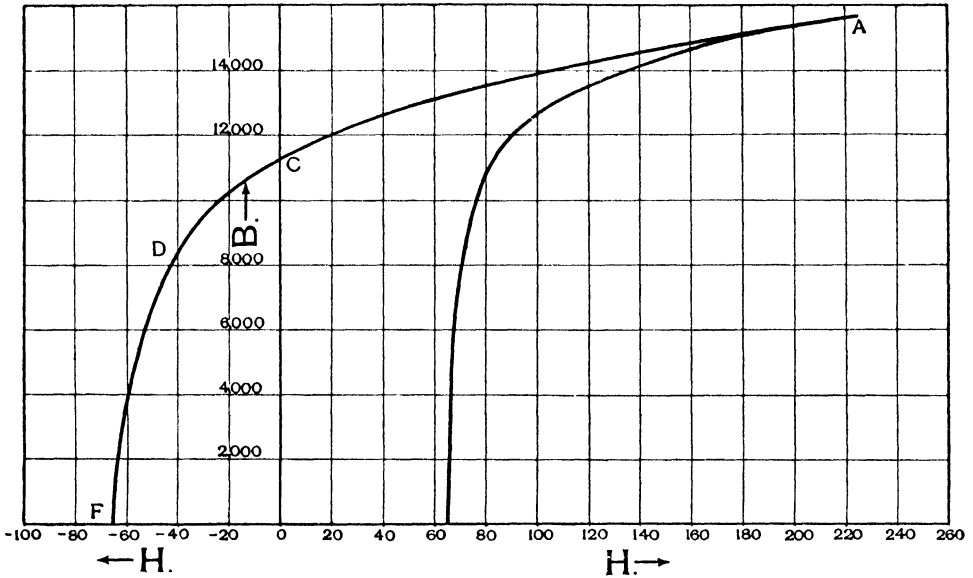

FIG. 21.

The total magnetic flux across the gap is

$$\phi = B_g A_g$$

The m.m.f. necessary to drive this flux across the gap is

$$V_g = B_g l_g,$$

where V_g is termed the *magnetic potential difference* across the gap.

The total energy stored in the gap may therefore be written

$$\frac{\phi V_g}{8\pi} \text{ ergs}$$

It is convenient for many purposes to write the expression

$$\phi = B_g A_g$$

in the form

$$\phi = V_g \left(\frac{A_g}{l_g} \right)$$

or

$$\phi = G V_g$$

where G is the *magnetic conductance* of the air-space.

22. The Demagnetisation Curve for Magnet Steel

If steel in the form of a closed iron ring be magnetised to a condition of magnetic saturation, *e.g.*, the point A in Fig. 21, and if

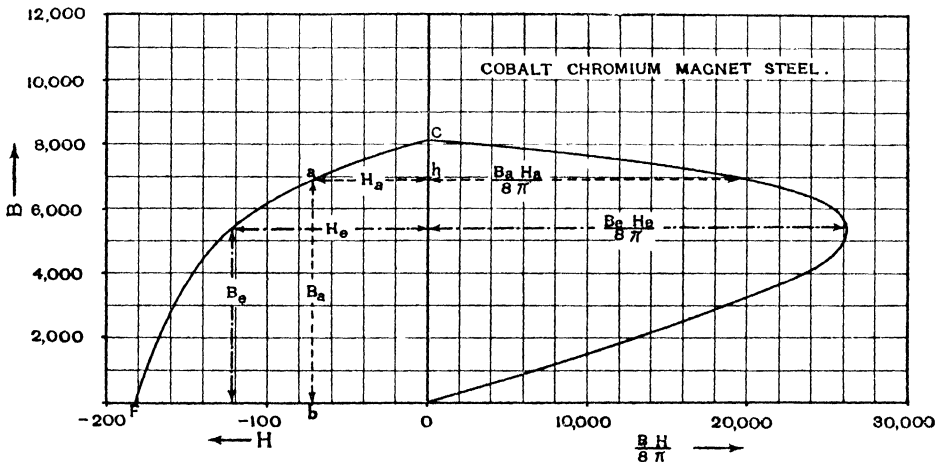

FIG. 22

the magnetising force is now removed, the steel ring will remain magnetised to an amount represented by OC in Fig. 21, that is to say, OC is the remanent induction B_{rem} .

If now a negative or demagnetising force be applied, the flux density will be reduced, and if the corresponding values of the demagnetising force H and the flux density B be plotted, the curve CDF will be obtained. This curve CDF is the *demagnetisation curve* of the steel, and the information given by this curve is of cardinal importance in the design of permanent magnets.

In Fig. 22 the demagnetisation curve is shown for cobalt–chromium magnet steel. The curve shows that *for the case of a closed ring of the steel* if any demagnetising force $H_a = ha$ be applied, a flux density $B_a = ba$ will exist in the closed steel ring. That is to say, *after subtracting the demagnetising force ha there is a nett balance of the m.m.f. inherent in the steel which is just sufficient to maintain a flux density equal to ba .*

Looked at in another way, it may be said that *when a flux density equal to ba exists in the steel there is an inherent m.m.f. of magnitude ha per cm. length of the steel which is available for driving the flux across an air-space in the magnetic circuit.*

The demagnetisation curve CF , Fig. 22, may therefore be looked on as a measure of the m.m.f. H_a per cm. length of steel which is available for driving the flux across an air-space, when any given flux density B_a exists in the steel—it being remembered that *this demagnetisation curve is obtained by first magnetising the steel to saturation.*

When used for this purpose, it would be more strictly logical to draw this curve so that it comes on the positive side of the vertical axis. If, however, the foregoing explanation of the significance of the demagnetisation curve be carefully borne in mind, there is not likely to be any confusion if this curve is drawn as shown in Fig. 22.

Now suppose that the magnet, Fig. 20, has a length of L_s cm. Then for any point a , Fig. 22, on the curve CF , the m.m.f. per cm. length of the steel will be H_a . The total m.m.f. for the whole length of the steel will therefore be

$$H_a L_s,$$

and this is the m.m.f. which is available for driving the magnetic flux across the air-space.

But this is the magnetic potential V_o across the air-space.

Hence

$$V_o = H_a L_s.$$

Let A_g sq. cms. be the cross-sectional area of the air-gap,
 „ A_s „ „ „ „ „ „ steel,
 „ B_g be the induction in the air-gap,
 „ B_s „ „ „ „ „ steel,

then the magnetic flux will be

$$\phi = A_g B_g = A_s B_s.$$

It follows, therefore, that

$$\phi V_g = H_a B_a L_s A_s.$$

Now $\frac{\phi V_g}{8\pi}$ ergs is the total energy stored in the magnetic field in the air-gap (see § 13, Chapter I).

Hence the magnetic energy in the air-gap which each c.c. of the steel is capable of maintaining is

$$\frac{H_a B_a}{8\pi} \text{ ergs}$$

Now if the value of the products $\frac{H_a B_a}{8\pi}$ be found for various points on the curve CF , Fig. 22, and if the values of these products be plotted as abscissæ with the corresponding values of B_a as ordinates, the curve given on the right-hand side of the vertical axis in Fig. 22 will be obtained.

It will be noticed from Fig. 22 that the product $\frac{H_a B_a}{8\pi}$ has a maximum value, and consequently *the values of B_a and H_a respectively which correspond to this maximum will be the values which will give the most economical design, that is, the minimum amount of steel for maintaining a given amount of energy in the air-gap.* That this is so, is evident from the expression for the requisite volume of steel given above.

In comparing the magnetic qualities of steel intended for use as permanent magnets, the maximum value of the product $\frac{H_a B_a}{8\pi}$, as obtained from a curve such as Fig. 22, is the criterion of merit for the steel.

The volume of steel necessary for storing the energy $\frac{\phi V_g}{8\pi}$ ergs in the air-gap is *

$$\frac{\phi V_g}{8\pi} \frac{8\pi}{H_a B_a} = \frac{\phi V_g}{H_a B_a} \text{ c.c.}$$

Let B_e and H_e be the corresponding values of the induction and the available inherent m.m.f., respectively, such that their product is a maximum (see Fig. 22). The value of the product $\frac{H_e B_e}{8\pi}$ gives the maximum amount of energy in ergs per c.c. of the steel which that steel can maintain in an air-gap.

In the following Table, numerical values are given for iron and for various qualities of steel.

TABLE

Material.	Maximum Energy $\frac{B_e H_e}{8\pi}$ in Ergs per c.c.
Lowmoor Iron, Annealed	183
Mild Steel, Hardened	970
Tungsten Steel (0.7% Carbon, 5% Tungsten), Hardened	13,100
Hadfield's "Permanite"	24,400
Cobalt-Chromium Steel (1% Carbon, 9% Cobalt, 9½% Chromium)	26,200
Cobalt Steel (35% Cobalt)	31,800

Fig. 22 refers to cobalt-chromium steel, for which the following values have been obtained, viz. :

$$B_e = 5400 \text{ lines per sq. cm.}$$

$$H_e = 121 \text{ gauss,}$$

$$\frac{B_e \times H_e}{8\pi} = 26,200 \text{ ergs per c.c.,}$$

and this is the maximum amount of magnetic energy which one c.c. of this quality of steel can store. From what has been said it will be clear that a permanent magnet which is most economical of

* Magnetic leakage has been neglected here. For the method of taking leakage into account, reference should be made to Mr. Evershed's paper quoted above.

material will be obtained when the flux density in the steel is $B_e = 5400$.

Let L_e cms. be the length and A_e sq. cms. be the cross-sectional area of this most economical magnet.

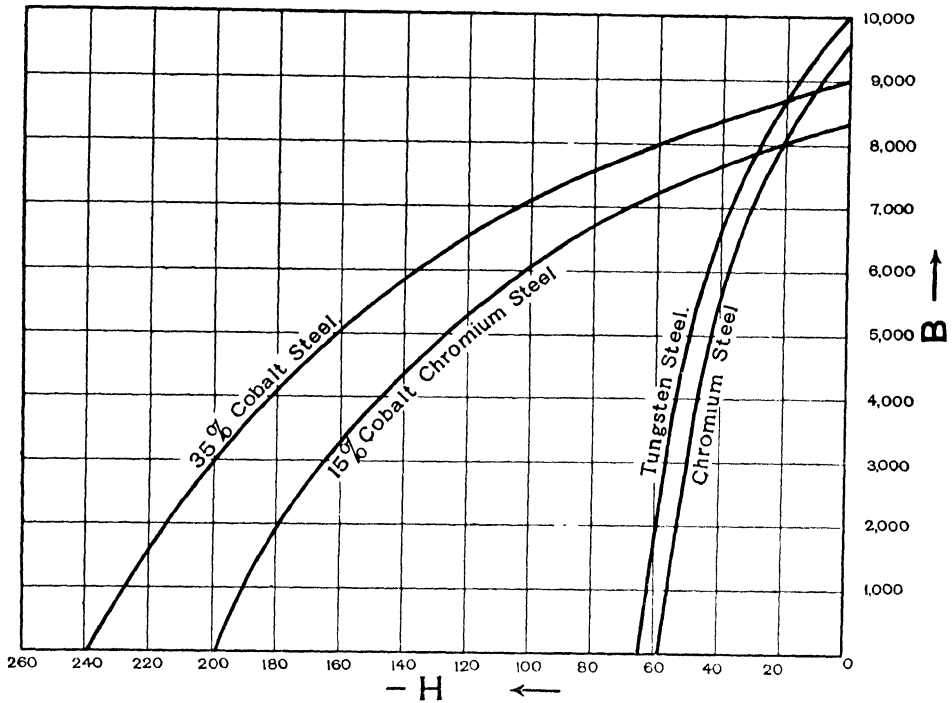

FIG. 23.

Then the magnetic flux across the gap will be

$$\phi = B_e A_e$$

and the magnetic potential across the gap will be

$$V_g = L_e H_e$$

and $A_e L_e$ c.c. is the smallest volume of the steel which can maintain the amount of energy $\frac{V_g \phi}{8\pi}$ ergs in the air-space.

In Fig. 23 are shown typical demagnetisation curves for four qualities of permanent magnet steels.*

* See E. A. Watson, *Journal of the Institution of Electrical Engineers*, 1925, Vol. LXIII, p. 822.

23. The Useful Energy which a Magnet of Given Dimensions can maintain in an Air-space

Using the relationships obtained in §§ 21 and 22, viz. :

$$\begin{aligned}\phi &= A_g B_g \\ V_g &= H_a L_s\end{aligned}$$

and dividing one by the other, gives

$$\begin{aligned}\frac{\phi}{V_g} &= \frac{A_g B_g}{L_s H_a} \\ \text{or} \quad \frac{B_g}{H_a} &= \frac{L_s}{A_g} \frac{\phi}{V_g}\end{aligned}$$

The ratio $\frac{\phi}{V_g}$ is the magnetic conductance G of the air-space, and this may be calculated for any given form of the boundaries of the air-space.

Since the ratio $\frac{L_s}{A_g}$ is known from the dimensions of the magnet, the ratio $\frac{B_g}{H_a}$ becomes fixed, and the corresponding ratio $\frac{B_a}{H_a}$ is obtained.

That is,

$$\frac{B_g}{H_a} = \frac{L_s}{A_g} \times [\text{Magnetic conductance of the air-space}]$$

$$\text{or} \quad \frac{B_a}{H_a} = \frac{L_s}{A_s} \times [\text{Magnetic conductance of the air-space}]$$

since $B_g A_g = B_a A_s$.

If, therefore, a point on the $B_a : H_a$ curve of Fig. 22 be found so that the ratio of these two quantities is equal to that given by the above expression, it at once follows that

$$\begin{aligned}\phi &= B_a A_s \\ V_g &= H_a L_s,\end{aligned}$$

and therefore the magnetic energy which the given magnet can maintain in a given air-space is at once found.

24. Some Practical Notes on Permanent Magnets *

In many practical applications it is essential that a permanent magnet shall remain as constant as possible for long periods of time. Examples of such cases are moving coil ammeters and voltmeters and the brake magnets of electric supply meters.

A permanent magnet becomes gradually weaker with age. For example, the coercive force of steel is a maximum immediately after hardening, and the value of the coercive force rapidly decreases during the first few hours afterwards. At the expiration of a few months the rate at which the coercive force decays becomes small and remains more or less constant.

In Fig. 24 is shown the decrease of coercive force with time for hardened tungsten magnet steel and in Fig. 25 a similar curve is shown for hardened cobalt magnet steel.

The causes of loss of magnetisation may be summarised as follows :

(I) Loss of coercive force of the hardened steel magnet due to a metallurgical change in the material.

(II) Loss of magnetisation due to the breakdown of the stability of feebly-oriented groups of molecules.

In the following, a short account is given of these several causes of loss of magnetisation.

(I) *Loss of Coercive Force Due to a Metallurgical Change in the*

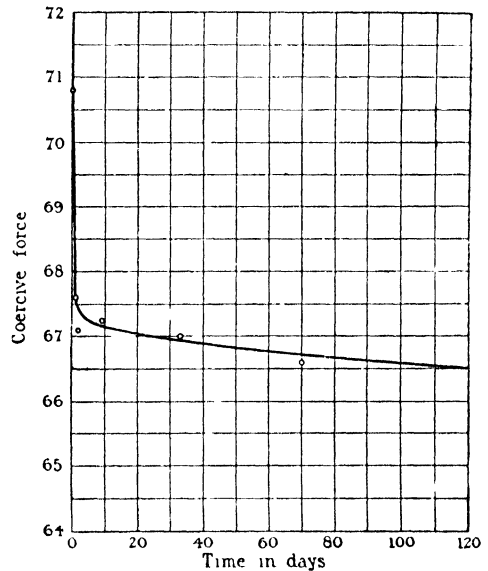

FIG. 24.

* See S. Evershed, *Journal of the Institution of Electrical Engineers*, 1925, Vol. LXIII, p. 725.

Material.—As shown in Figs. 24 and 25, the coercive force of a hardened steel magnet falls off rapidly at first and then decays at a much slower rate. This decay of coercive force with time is supposed to be due to the passage of the carbide molecules out of solution. That is to say, the steel is itself changing its structure. This

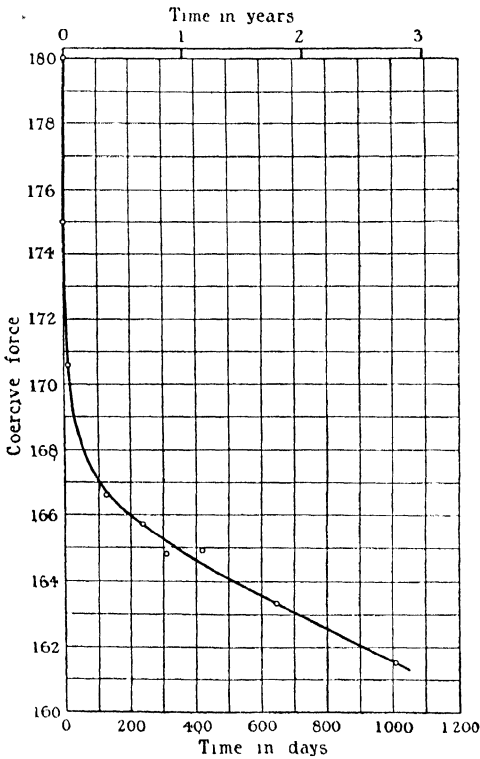

FIG. 25.

gradual structural change of hardened steel appears to be inevitable. It is, however, possible, by artificially increasing the initial rate of decay, to bring the magnet into a state for which the rate of decay is small. In other words, it is possible to pass artificially to that part of the curve of rate of decay of coercive force (see Figs. 24 and 25) which corresponds to a period of several years from the time of hardening. This is done by heating the steel to a suitable temperature, thus temporarily increasing the mobility of the molecules so that a fraction of the carbide is caused to pass quickly out of solution. This process is termed "ageing," because it is

an artificial equivalent to the long term of years which naturally would be required to arrive at the same result.

For example, it has been found that in the case of hardened tungsten magnet steel, if the temperature is raised to 100°C ., say, by immersion in boiling water, the total decay of coercive force in 1.1 hours is the same as the decay which would have taken place in 1 year at a temperature of 18°C .

(II) *Loss of Magnetisation Due to the Breakdown of the Stability*

of *Feebly-oriented Groups of Molecules*.—In a permanent magnet, the molecules are maintained in oriented groups and the stability of any group is dependent on the mutual induction effects between this group and neighbouring groups. There will be a number of groups with a small margin of stability and which therefore will easily lose their orientation.

Any impressed effect, therefore, which will upset the balance of the less stable groups will cause the remanence to be correspondingly reduced. For instance, the feebly stable groups may be de-oriented by :

- (a) The action of stray magnetic fields.
- (b) Molecular vibration due to mechanical shock.
- (c) Molecular vibration due to heat.

(a) *The Action of Stray Magnetic Fields*.—If at any point of the demagnetisation curve of a magnet the demagnetising force is decreased and then increased, the values of the induction B so

obtained do not fall on the original demagnetisation curve. For example, in Fig. 26 the point R represents the remanent magnetisation when H is zero, this point having been reached by way of the demagnetisation curve MR .

In Fig. 26 the ordinates give the intensity of the magnetic field due to the molecules themselves, that is, the value of $4\pi J$, whilst the abscissæ give the intensity H of the magnetising (or demagnetising, force impressed on the magnet.

If a demagnetising force is now applied to the specimen, the

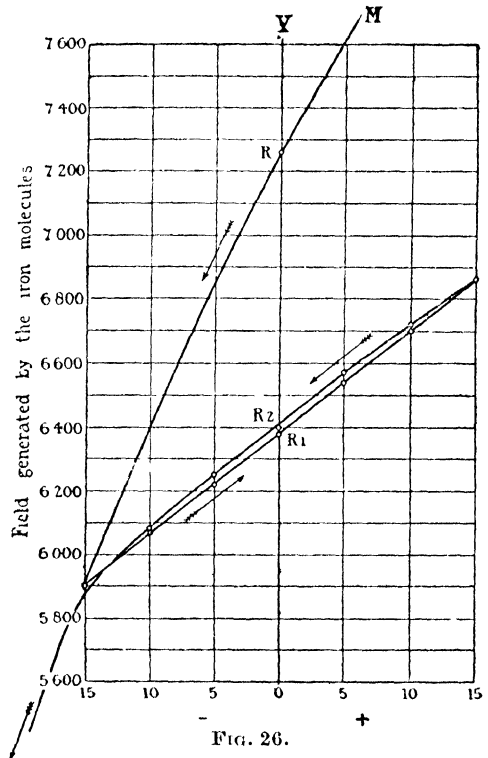

relationship between $4\pi J$ and H will be given by the continuation of the curve MR as shown. Suppose that, having reached a value of 15 units, the demagnetising force is reduced to zero and then a magnetising force of 15 units applied, after which the magnetising force is reduced to zero and a demagnetising force of 15 units is applied. In this way a subsidiary hysteresis loop R_2R_1 will be obtained as shown in Fig. 26.

When the demagnetising force is now removed, the remanent magnetisation will be given either by R_2 or R_1 , according to whether the value of H has been reduced to zero from a positive value or a negative value as shown by the arrows in Fig. 26.

Should a stray field be now impressed on the magnet, the change of the intensity $4\pi J$ will be defined by the subsidiary loop R_2R_1 . When the stray field is removed, the magnetisation returns very closely to the value of the remanence which existed before the stray field was introduced.

In this way, not only is the actual effect of the stray field on the strength of the magnet reduced to a minimum, but the magnetisation returns to practically the same value after the stray field has been removed.

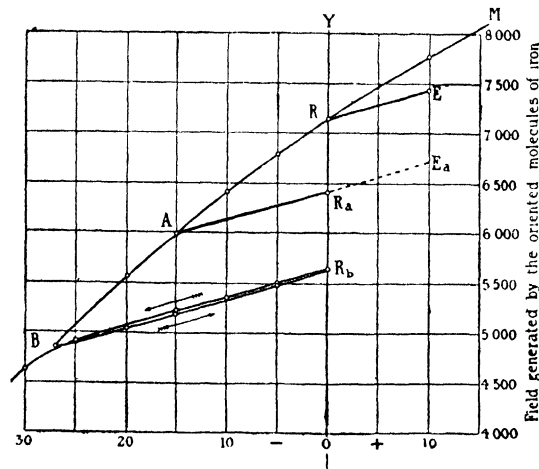

FIG. 27.

If the stray field is not likely to exceed a value of, say, 15 units, it is sufficient to carry the magnetisation through a subsidiary loop the limits of which are $H = \pm 15$.

Referring now to Fig. 27, which gives the demagnetisation curve for the same magnet steel as Fig. 26 with a number of subsidiary hysteresis loops shown. Suppose that, having reached the point

the value of the remanence which existed before the stray field was introduced.

Referring now to Fig. 27, which gives the demagnetisation curve for the same magnet steel as Fig. 26 with a number of subsidiary hysteresis loops shown. Suppose that, having reached the point

$R = 7160$, a demagnetising stray field of 15 units is impressed on the specimen which brings the magnetisation to the point A . If the stray field is now removed, the magnetisation will reach the value given by R_a , that is, 6410 units. That is to say, the stray field has caused a reduction in the permanent magnet strength of 10.5%. Comparing this with Fig. 26, it is seen that if, before putting the magnet into service, the remanence has been brought to the value R_2 or R_1 by means of the subsidiary hysteresis loop, the change in the remanence would be only about 0.25%.

The foregoing considerations refer to a bar magnet, and this is the worst possible case. If the magnet is in the form of a horse-shoe with the poles close together, *e.g.*, the brake magnet of an electricity meter, and if the remanence has been brought to some value R_a , a stray field will then produce an effect defined by $R_a A$ on one pole, and by $R_a E_a$ on the other pole, so that the nett effect on the magnet becomes practically zero.

(b) *Molecular Vibration Due to Mechanical Shock*.—In S. Evershed's paper the following experimental data are recorded showing the effect of mechanical shock on the magnetisation.

A magnet of tungsten steel was prepared in the form of an ellipsoid and the remanent flux density was measured by a magnetometer and found to be 7310. The magnet was then submitted to mechanical vibration by giving it 500 blows and the effect of this was found to decrease the remanent flux density to 7010, that is, a fall in remanent flux density of 300 lines per sq. cm. The magnet was then remagnetised fully and the remanence was found to have regained its former value of 7310 lines per sq. cm. A demagnetising field of 7 units was then impressed on the magnet and removed, thus reducing the remanence to a value of 6890 lines per sq. cm. In accordance with what was said in (a), above, the stability of the magnet was thereby increased and the remanence was thereby rendered immune to stray fields of magnitude up to 7 units.

The question then arose as to whether the magnet was also rendered more immune to the disturbing effects of mechanical shock, by reason of the stabilising partial demagnetisation. To answer

this question, the magnet was again subjected to 500 blows of the same energy as those given in the previous test. The result of this was to diminish the remanence flux density from 6890 to 6830 lines per sq. cm., that is, a loss of 60 units.

This experiment showed that the application of a subsidiary hysteresis loop, as explained in (a), above, not only renders the magnet less sensitive to the effects of stray fields, but also renders it less affected by mechanical vibrations.

(c) *Molecular Vibration Due to Heat.*—The molecular vibration due to heat is similar in its effects on the remanent magnetism to the molecular vibration due to mechanical shock.

In order to obtain definite data on this point, S. Evershed gives the following results of experiments. Two tungsten steel magnets were prepared as nearly as possible alike. These magnets were not subjected to any heat treatment after hardening.

Magnet No. 1 was then fully magnetised and the remanence was found to be 7220. The magnet was then heated to 100° C. for successive periods, amounting in all to 13·7 hours. The total reduction in remanence was then found to be 930 units. Of this amount, 230 units were due to the decay of the steel, as explained in (I), above, and the balance of 700 units was therefore due to the molecular vibration due to the heating.

Magnet No. 2 was then fully magnetised and the remanence was found to be 7130 units. After subjecting the magnet to several temporary applications of a demagnetising field of 18 units, the remanence was found to be 6345 units. The magnet was then heated to 100° C. in successive periods for a total time of 13·4 hours. The result was that the remanence became reduced by 185 units, of which amount 130 units were due to decay in the steel (see I, above) and the balance of 45 units was due to the vibrational effect of the heating.

This experiment again shows that subjecting the magnet to a subsidiary hysteresis loop by the application and removal of a demagnetising field results in a reduction of the deteriorating effect of molecular vibration due to heat.

CHAPTER III

SOME METALLURGICAL FACTS AND THEIR RELATIONSHIP TO THE MAGNETIC PROPERTIES OF IRON AND STEEL.

25. Changes of State of Pure Iron when Heated to Melting Point or when Cooled Down from the Melting Point

IT has been known for more than 300 years that if iron is heated to redness it becomes non-magnetic. About 60 years ago, C. Gore showed that when iron is heated to redness, not only does it lose its magnetic properties, but that there are also marked changes in its specific heat, electric resistance and other properties. Fifty years ago Barrett discovered the fact that when iron is heated to bright redness and then allowed to cool down to a deep red colour, it suddenly brightens up again, as though heat energy had been released within the iron itself. To this sudden brightening the name of "recalescence" has been given.

If a cooling curve is plotted, the point of recalescence will be marked by an arrest in the rate of cooling, that is, by a change in the curvature of the cooling curve.

This property of the sudden change in the rate of cooling due to a change of state is not peculiar to iron; a common example of the same phenomenon is found when water is cooled through the freezing point. For example, if water is allowed to cool down through the freezing point to a temperature of about -20° C., and if a cooling curve be plotted, this curve will show a sudden change of curvature when the freezing point of water (0° C.) is reached. The shape of the curve is shown in Fig. 28.

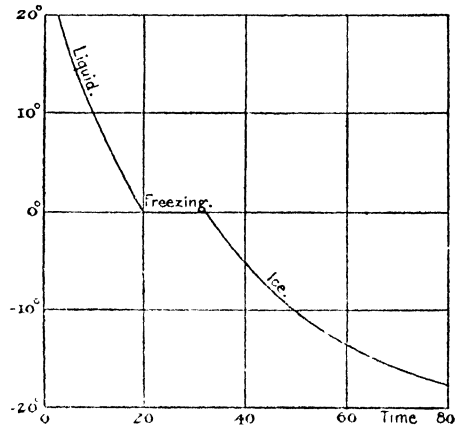

FIG. 28.

In Fig. 29 is shown a part of the cooling curve for a sample of steel in which recalescence is accompanied by a marked rise of temperature.

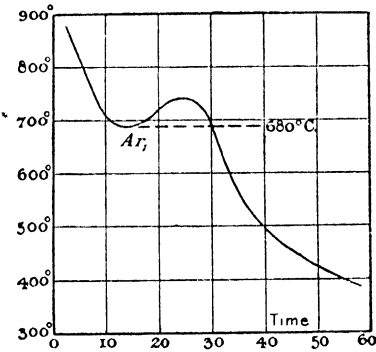

FIG. 29.

The detailed examination of the phenomenon of recalescence has received great attention from numerous investigators, the systematic observation of the changes of state of iron and steel during cooling and heating being commenced by F. Osmond in the year 1887.

In order that the change of curvature of the cooling curves should be as clearly evident as possible, Osmond devised the following method of plotting

the curves. Instead of plotting the temperature and time as co-

ordinates, he plotted the temperature and the inverse rate of cooling as co-ordinates. That is to say, the number of seconds were measured for a fall of temperature of 1° and the "time per degree" was plotted against the temperature. If the normal rate of cooling becomes interfered with due to a change of state, this is shown on Osmond's curve by a marked deviation.

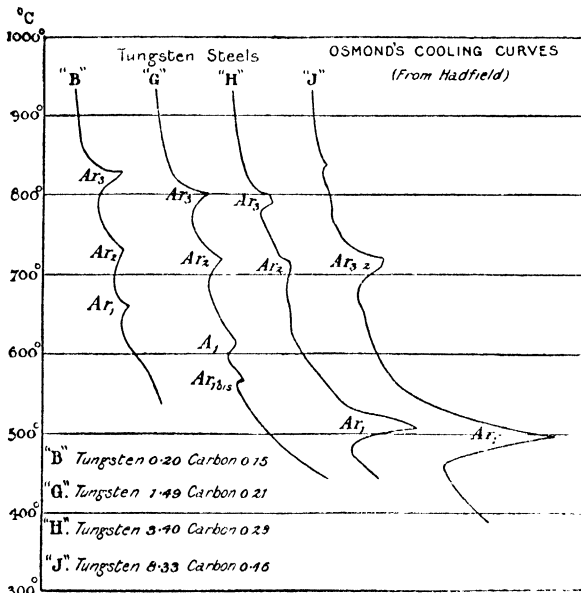

FIG. 30.

In Fig. 30 are shown examples of Osmond's inverse rate of cooling curves.

Comparatively recently, some very accurate quantitative measurements have been made relative to the changes of state of pure iron by Wüst, Meuthen, and Durrer, and in Fig. 31 is shown a diagram prepared by S. Evershed and based on these and other results.

Pure solid iron can exist in at least four different allotropic states, viz., Alpha iron, Beta iron, Gamma iron, and Delta iron. Pure iron remains in the Alpha state for temperatures up to about 770° C. Iron in the Alpha state is magnetic. It has an atomic weight of 55.85 and at 0° C. it has a specific heat of 0.1055.

When Alpha iron is magnetised to saturation, that is, when all the molecules are fully oriented, the magnetic moment of the iron is 1700 c.g.s. units per c.c. That is to say, the intensity of magnetisation is $J = 1700$. This is equivalent to a magneto-motive force of iw ampere-turns per cm. length, where

$$\frac{4\pi}{10} iw = 4\pi J = 4\pi \cdot 1700 \text{ (see Chapter I).}$$

or

$$iw = 17,000 \text{ ampere-turns per cm. length.}$$

This result shows what a remarkably high value of magneto-motive force is to be allotted to the inherent magnetism of the molecules of the iron (see also § 20).

When iron is heated, the apparent specific heat gradually increases, that is to say, all the heat communicated to the iron is not utilised in raising the temperature. A similar effect is found in nearly all metals and generally occurs as the melting point is approached. In iron, however, the effect appears immediately above

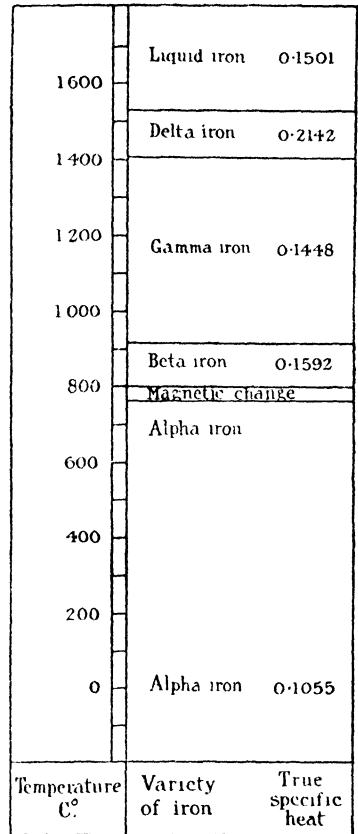

FIG. 31.

0° C. and finishes somewhere about 750° C., whereas the melting point of iron is about 1540° C.

At a temperature of about 770° C., Alpha iron begins to change into Beta iron. This change of state is accompanied by a marked change in the specific heat and a complete loss in magnetisability. Abrupt changes in mechanical and other properties are also noted. There is, in fact, a profound change in the atomic structure of the iron.

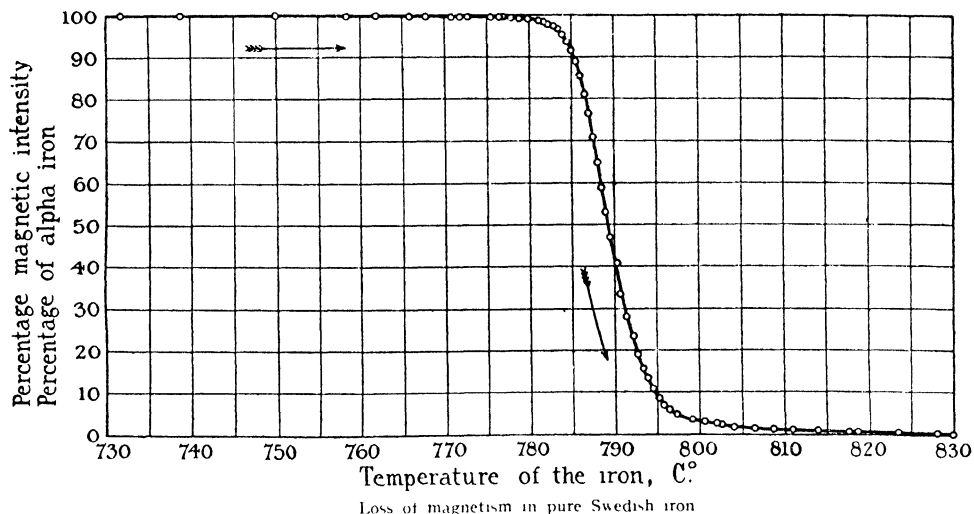

Fig. 32.

In Fig. 32 is shown a curve connecting the saturation intensity of magnetisation as a percentage of the saturation intensity observed when the iron is wholly in the Alpha state, and the temperature, over a range covering the transformation from Alpha iron to Beta iron. It is seen that at about 770° C. the saturation intensity of magnetisation begins to fall and at about 830° C. it has become zero. This curve refers to very pure Swedish iron as tested by S. Evershed. It is found that, within the limits of experimental error, the same curve is traced out as the iron *cools* from 830° C. downwards.

At any temperature between about 770° C. and 830° C., the iron exists partly as Alpha iron and partly as Beta iron, that is, partly

magnetic and partly non-magnetic, and the percentage saturation magnetic intensity at any stage in the transformation is also the percentage of Alpha iron in the total mass of iron.

If the iron is heated beyond about 800° C., it remains in the Beta state until a temperature of about 919° C. is reached. Beta iron is then converted entirely into Gamma iron if sufficient time is allowed. When the iron passes from the Beta to the Gamma state, further abrupt changes in the mechanical and other properties occur, but the iron remains non-magnetic. The specific heat of Gamma iron is constant.

If the iron is still further heated, another critical temperature is reached, viz., about 1404° C., when Gamma iron is changed into Delta iron, the effect being accompanied by a sudden increase of about 50% in the specific heat. If heated still further, the iron remains in the Delta state up to the melting point. The specific heat of Delta iron is constant and hence there is no absorption of energy as a preliminary to fusion.

At a temperature of 1528° C. pure iron melts, there is a large absorption of energy, a sudden decrease of specific heat and an abrupt loss of mechanical strength.

When molten iron cools, the aforementioned changes of state take place in the reverse order, and in the case of pure iron the temperature at which the respective changes of state occur are the same when the iron cools down as when it is heated.

The specific resistance of iron changes in a striking manner in the neighbourhood of the critical temperature, 765° C. Hopkinson and Morris * showed that the mean temperature coefficient † of iron at a temperature in the neighbourhood of 0° C. is about 0.0057. At

* See *Phil. Mag.*, September 1897.

† The temperature coefficient of a conductor is related to the resistance as expressed by the following equation :

$$R_t = R_0 (1 + \alpha t),$$

where

R_t is the resistance at the temperature $t^\circ \text{C.}$,
 R " " " " " " 0°C. ,
 α is the temperature coefficient.

This linear relationship holds for a small temperature range and α is the mean value of the temperature coefficient for that range of temperature.

765° C., the temperature coefficient rises to a maximum value of 0.0204 and at 1000° C. falls to 0.00244.

26. The Effect of Temperature on the Magnetisation Curves for Iron

In § 25 it has been shown that, for a range of temperatures from

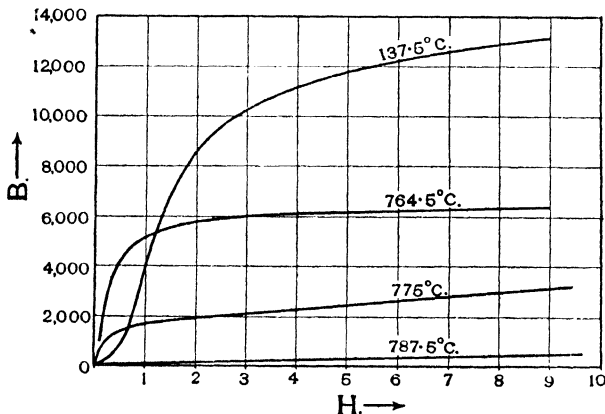

FIG. 33.

about 770° C. to about 830° C. the saturation intensity of magnetisation for pure iron may have widely different values according to the temperature at which the measurement is made (see Fig. 32). At the lower temperature of this range, the saturation intensity of magnetisation is about

the same as that obtained at normal room temperatures, whilst at the higher temperature of this range the iron becomes non-magnetic.

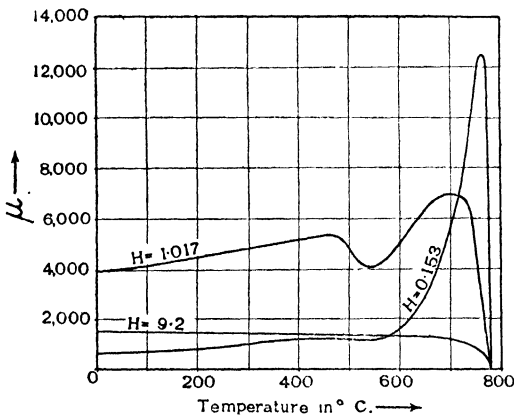

FIG. 34.

It is of interest to inquire what shape the magnetisation curves will have at various temperatures within this range of values. Such curves have been obtained by D. K. Morris* and are shown in Fig. 33. It will be observed that, as the temperature is increased, the whole magnetisation curve becomes lower, until eventually, at a temperature of

isolation curve becomes lower, until eventually, at a temperature of

* See *Phil. Mag.*, 1897, Vol. XLIV.

787.5° C., the iron has become almost non-magnetic. There is a further noteworthy feature about the curves of Fig. 33, viz., for low values of the magnetising force H , the permeability increases with the temperature. This is clearly shown in Fig. 34, in which the permeability is plotted as a function of the temperature for a series of values of the magnetising force. Specially interesting is the curve for $H = 0.153$, which shows that the permeability reaches the value of over 12,000 at a temperature of about 765° C., whilst if the temperature is further increased by only 15° C. the iron becomes entirely non-magnetic.

27. Steel a Solution

It is possible to dissolve in iron many elements, both alone and in combination. Further, not only do many elements dissolve in molten iron, but they can remain in solution when the iron cools down.

Carbon, when heated in contact with solid iron, will pass very slowly into the iron and dissolve in it, taking many hours to do what is done in a few seconds with the molten metal.

A solution in the solid state, like steel, differs from a liquid solution in degree only. For example, if the temperature of a liquid solution is lowered, the passage of the dissolved molecules from solution to crystal is extremely rapid. In solid steel, however, even when heated red hot to give greater mobility, the same process is found to occupy several minutes. When the steel is cold, the mobility is so slight that, in practice, it is ignored and cold steel is regarded as being in an unchangeable state. There is evidence, however, that, even when cold, the mobility is not quite zero.

Of the many substances which will dissolve in steel, the ones with which permanent magnet-makers are chiefly concerned are carbon, tungsten and chromium.

28. Carbon Steel

Under ordinary conditions, carbon only dissolves indirectly in iron. It does so by first combining with iron to form carbide of iron,

Fe_3C , and this substance then immediately dissolves in the remaining iron. Iron, however, is capable of dissolving only a very small amount of this or any other carbide.

Tungsten also combines with carbon to form carbide of tungsten, WC , which is soluble in iron. Chromium also combines with carbon as a carbide of chromium, Cr_3C_2 .

In carbon steel the only carbide present is the iron carbide. In tungsten magnet steel, both the carbide of iron and the carbide of tungsten are present, there being roughly the same number of molecules of each. In chromium magnet steel, both the carbides of iron and chromium will be present.

Each of the three carbides when in solution, and only when in solution, endows the iron with the property which makes it suitable for permanent magnets.

In magnet steels, the maximum amount of carbon used is about 1%.

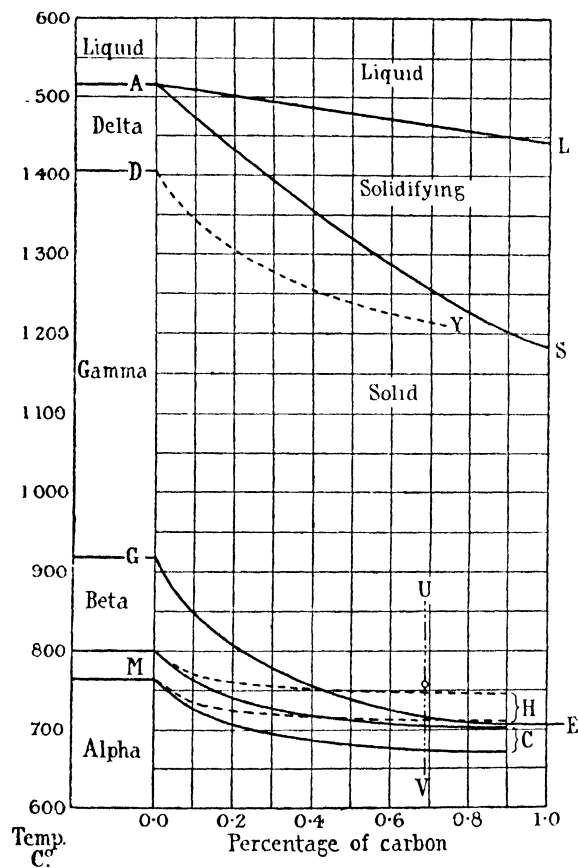

FIG. 35.

The transformation temperatures for carbon steel are shown in the chart of Fig. 35 for various percentages of carbon up to 0.9%.

When carbon is present in iron, the melting temperature falls, and this fact indicates that the carbon is actually dissolved in the iron. Moreover, there is a range of temperature over which the iron

is neither completely molten nor completely solid. This is shown in Fig. 35 by the boundary lines AL and AS .

The boundary line for the change from Delta to Gamma condition is not known quite definitely. The point D , however, is known for pure iron from Wüst's results, and a further point has been obtained by S. Evershed, viz., the point for 0.7% carbon content. As regards the curvature of this boundary line, it is assumed in Fig. 35 that the shape is similar to the boundary line between the Gamma and Beta stages.

The boundary line GE shows the change when cooling down from the Gamma to the Beta stage.

The zone MC is that within which the change from the Beta to the Alpha stage takes place during *cooling*, whilst the dotted zone MH is that within which the change from the Alpha to the Beta stage takes place during *heating*.

EXAMPLE.—An illustrative example of the behaviour of a pure carbon steel containing 0.687% of carbon will now be considered.* This steel is representative of the material which was commonly used for permanent magnets before the introduction of tungsten steel.

In Fig. 35 the vertical line UV has been drawn through the abscissa for 0.687% carbon and shows the changes of state as this particular specimen of steel cools down.

In Fig. 36 is shown the rate of change of temperature with time, as this steel cools down from about 750° C. to 570° C., that is, through the Gamma, Beta, Alpha transformations. In Fig. 36 are also shown the curve connecting the rate of change of temperature with the time (*i.e.*, $\frac{dT}{dt}$), viz., the curve PQR , and the curve showing the rate of change of magnetic intensity with the time (the bottom curve).

Having solidified and cooled down, the Gamma state is reached, the iron carbide, Fe_3C , being still held in solution. In Fig. 36 the

* See S. Evershed, *loc. cit.*

first sign of departure from the normal cooling is noticed at a temperature of 754°C . The rate of fall of temperature $\left(-\frac{dT}{dt}\right)$ begins to decrease rapidly, that is to say, heat is being released internally. The Gamma stage is now being passed and the Beta stage reached, with a consequent release of allotropic energy in the form of heat.

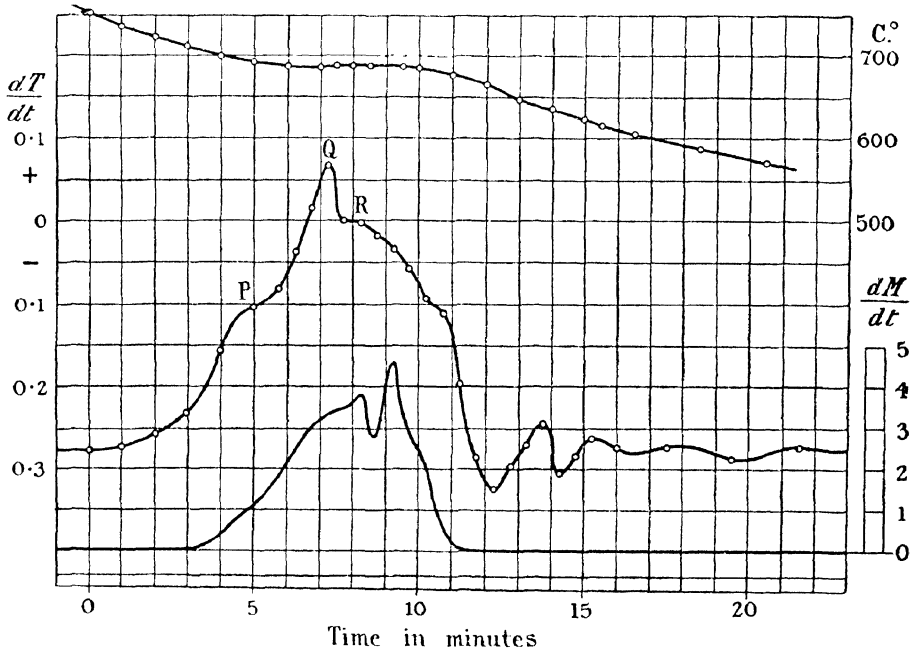

FIG. 36.

At the time marked 3 minutes in Fig. 36, that is, at a temperature of about 715°C ., the first sign of magnetisation appears and the rate of change of magnetic intensity $\left(\frac{dM}{dt}\right)$ assumes a positive value.

At the time marked $11\frac{1}{2}$ minutes in Fig. 36, the value of the $\frac{dM}{dt}$ curve falls to zero, which shows that the transformation from the Beta to the Alpha state is complete. The energy released during the transformation has been sufficient to produce slight recalescence,

the temperature curve reaching a maximum at the time 8 minutes, the $\frac{dT}{dt}$ curve being then zero (see the point *R*).

In Fig. 37 are shown two demagnetisation curves for this steel, viz.,

Curve A, for the steel in the softened state. From this curve it will be seen that the coercive force *H* is about $9\frac{1}{2}$ units and the remanent induction *B* about 10,400.

Curve B, refers to the steel completely hardened. From this curve it is seen that the coercive force is now about 48.5 units and the remanent induction *B* about 8,900.

In Fig. 38 are shown the curves of loss and recovery of magnetism for this steel with the temperatures plotted as abscissæ.

A comparison of these curves with the curve of Fig. 32 for pure iron

shows that the introduction of carbon has not only moved the curves to the left on the temperature scale, that is, the transformations take place at lower temperatures, but also there is now a marked difference between the heating and the cooling curves.

As already stated, for pure iron, the heating and cooling curves are coincident.

29. Tungsten Magnet Steel

Tungsten magnet steel may be described as carbon steel in which about half the carbide of iron has been replaced by carbide

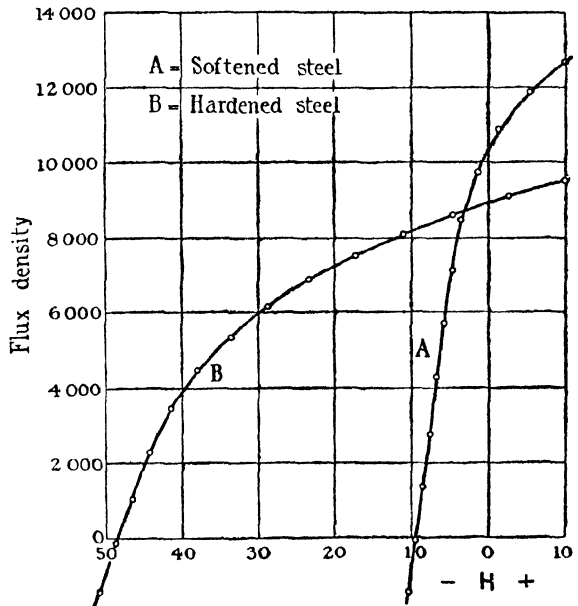

FIG. 37.

of tungsten, the total carbon content remaining the same. The effect of this is to increase the coercive force from less than 50 units to more than 70 units, and this leads to an increase of magnetic energy which the steel can maintain from about 7200 ergs per c.c. for carbon steel to about 14,000 ergs per c.c. for good tungsten steel. This improvement is all the more remarkable because carbide of tungsten by itself is unable to accomplish it.

The amount of tungsten commonly used in magnet steel at present is about 6%, the carbon content being from about 0.55% to 0.80%.

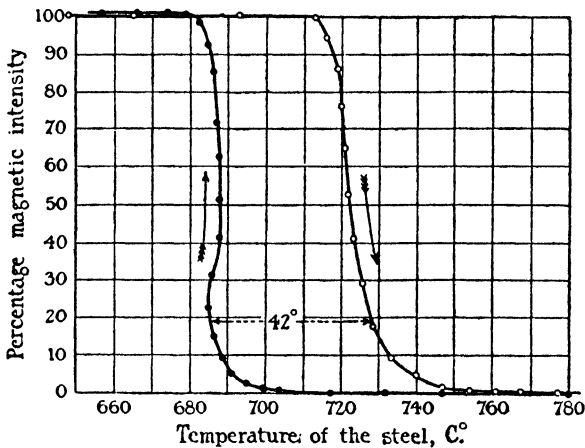

FIG. 38.

30. Chromium Magnet Steel

This steel may contain about 2% of chromium and 1% of carbon.

The value of chromium in steel for permanent magnets appears to be in dispute. Evershed states: "The most powerful solute considered solely as a source

of potency* is the carbide of chromium, the molecule of which is some eight or nine times as powerful as a molecule of carbide of iron. Unfortunately, carbide of chromium also has the power of preventing molecules of iron from assuming the magnetic state. Although as a solute molecule it provides great potency, yet at the same time carbide of chromium greatly depletes the steel of its magnetic molecules, and the loss of magnetic power from this cause outweighs the gain in potency. For this reason, chromium steel is inferior to tungsten steel as a material for permanent magnets. But by the introduction of another solvent, namely, an alloy of cobalt with iron, Professor Honda appears to have removed this

* That is, coercive force.

drawback and for the first time enabled carbide of chromium to be used without robbing magnetic molecules of their magnetism.”

31. Cobalt Magnet Steel

This type of steel may be divided into two sections, viz. (i) Low cobalt steel, and (ii) High cobalt steel.*

(i) *Low Cobalt Steel*.—As now used, this contains about 9% chromium, 0.8% to 1% carbon, and 9% to 20% cobalt. A small quantity of other alloys such as tungsten or molybdenum is added to improve the air-hardening properties.

(ii) *High Cobalt Steel*.—This type of steel was invented by Professor Honda of Tokio University and is sometimes called “Japanese Steel.” A usual composition for this steel is as follows: 35% to 36% cobalt, 3% to 4% tungsten, 1% to 2% chromium, 0.8% carbon, and a small quantity of manganese.

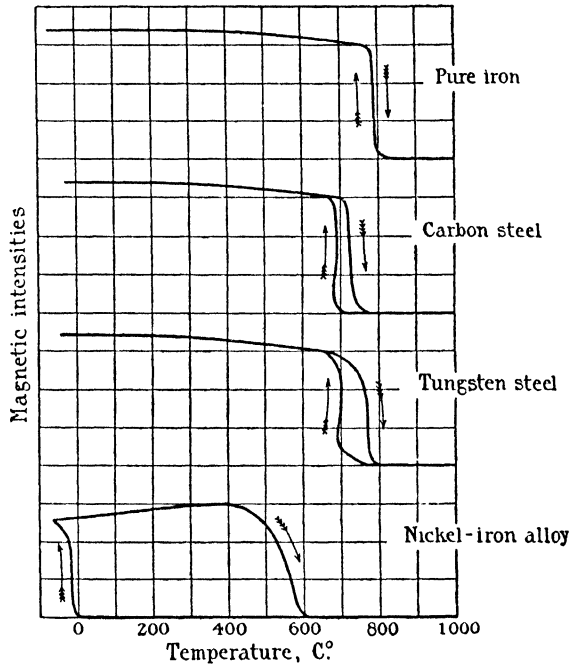

FIG. 39.

32. Curves of Loss and Recovery of Magnetism for Various Materials

In Fig. 39 is given a set of curves showing the loss and recovery of magnetism in pure iron, carbon steel, tungsten magnet steel, and nickel iron alloy, respectively. The last-named is specially interesting. It refers to the nickel iron alloy discovered by Hopkinson and

* See E. A. Watson, *Journal of the Institution of Electrical Engineers*, 1925, Vol. LXIII, p. 822. Also *Electrician*, 1920, Vol. LXXXV, p. 706.

has a composition of 1 part of nickel to 3 parts of iron. From this curve it appears that for a temperature range of about 0°C. to 600°C. the alloy may be either magnetic or non-magnetic, according to whether that temperature has been reached by heating the alloy from 0°C. or cooling it down from 600°C.

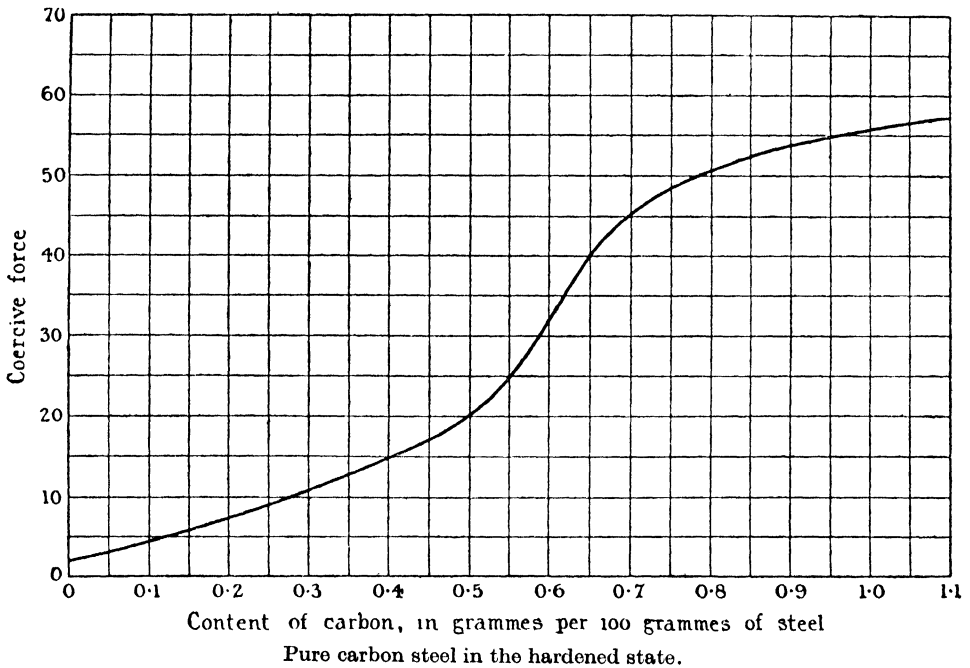

FIG. 40.

33. Hardening

In a permanent magnet it is, of course, necessary that the iron shall be in the Alpha state, since this is the only magnetic state. Normally, Alpha iron will dissolve an amount of carbide of iron such that the carbon content of the iron is about 0.03% , and such iron has a coercive force of about 9 units (see Fig. 40). For pure iron in the Alpha state, the coercive force is only about 2 units (see Fig. 40).

To make a powerful magnet, there must be great coercive force and a high value for the inherent magneto-motive force, and both factors must be taken into account in determining the best percentage

of carbon compounds to insert in the steel. It has been found by experiment that a permanent magnet maintains the maximum amount of useful magnetic energy when the steel contains about 0.72% of carbon in the form of soluble carbides, the whole amount being in solution.

In order that the steel shall have the coercive force which is requisite in a permanent magnet, two operations are necessary: (i) the whole quantity of carbide in the steel must be dissolved, and (ii) whilst the carbide molecules are still in their solution positions they must be deprived of their mobility. In this way, the whole of the carbon present in the magnet steel may be made to be effective in producing a high value for the coercive force.

What the hardening process effects is the solution of the whole of the carbon, notwithstanding the fact that the solvent iron is in the Alpha state, and since the amount of carbon in magnet steel is about 20 times as much as Alpha iron can naturally dissolve, it seems reasonably certain that the molecular condition in the hardened steel is not a state of equilibrium. Further reference to this matter is made in § 24 (see also Figs. 24 and 25), Chapter II.

Taking the two parts of the hardening process in turn, the first part is the dissolving of the whole of the carbon. Now any of the allotropic modifications of iron, other than Alpha iron, will readily dissolve a good deal more carbon than 0.72%. The first step, therefore, is to transform the iron into the Beta, Gamma or Delta state, by heating the steel to the proper temperature. Although any of these states of iron will dissolve all the carbon, no one of them does so better than the others. Hence, there is nothing to be gained by raising the temperature beyond the point at which the whole of the iron assumes the Beta form.

For example, in tungsten magnet steel, the conversion of the Alpha state into the Beta state is completed at a temperature of 790° C. Allowing a small margin, therefore, the steel should be raised to a temperature of about 820° C. and maintained at that temperature for 3 or 4 minutes. By this time the carbon will have been completely dissolved. The complete solution of the carbon,

however, has only been obtained by converting the steel into the non-magnetic Beta state. It is now necessary to transform the steel into the magnetic or Alpha state by reducing the temperature, without, however, allowing the carbide to pass out of solution during the process of cooling. That is to say, the cooling process must be so quickly carried out that it is completed before the carbide has had time to crystallise out.

The second operation in the hardening process, therefore, consists in causing the temperature of the steel to drop as quickly as possible from some point at which the whole of the carbon is in solution down to the temperature of the atmosphere.

When the temperature has fallen to about 100° C., the steel may be said to be cold in so far as the hardening is concerned. The obvious method of rapidly cooling the steel down to about 100° C. is to immerse it in cold water. Red-hot steel immersed in cold water, however, produces a film of steam round the metal, and this film being of low heat conductivity, there is a possibility of an appreciable time elapsing before the cold water can get into contact with the metal. To guard against the danger that the steel may in this way cool slowly to a temperature below the critical value, the temperature of the steel at the moment of immersion should be well above the critical point.

It has been found that a small increase of coercive force is obtained if the temperature of the cooling water is 50° C.

A nearly saturated solution of calcium chloride used as the cooling liquid is of value in preventing the splitting of cylindrical bars which so frequently occurs when quenched in water.

The following notes on the heat treatment of cobalt steel are of interest (see § 31).*

(i) *Low Cobalt Steel*.—“The heat treatment of this steel is somewhat complicated, but, on the other hand, it does not require such accurate temperature control as do the other steels. It usually consists in a preliminary heating to 1150° C. in order to break up the complex carbides which are present in the annealed bar and to ensure

* See E. A. Watson, *loc. cit.*; also *Electrician*, 1920, Vol. LXXXV, p. 706.

thorough solution of the carbides. This is generally followed by a quick annealing at about 750° C. to break up the austenite formed at the previous treatment, and this again is followed by heating up to about 1000° C. and cooling in air. Considerable latitude can be given on the temperature of the first two treatments, and a tolerance of $\pm 20^\circ$ C. can usually be allowed on the latter, but careful control of the cooling rate is necessary. These steels are remarkably free from troubles due to cracking and distortion."

(ii) *High Cobalt Steels. (Japanese Steel.)*—"These steels are all oil-hardening with a single treatment only. They give little trouble with distortion or cracking, but accurate temperature control is essential, as a slight elevation of temperature above the absorption point promotes the retention of austenite with a low remanence. The cooling rate is also of importance, and it is hence important to use an oil of the correct viscosity and to control its temperature."

The author acknowledges his indebtedness to papers in the *Journal of the Institution of Electrical Engineers* by S. P. Thompson (1913, Vol. L), and S. Evershed (1925, Vol. LXIII), for information on the subject matter of this chapter, and for a more complete discussion reference should be made to these papers and also to *The Electrician*, December 1920.

CHAPTER IV

SOME CHARACTERISTICS OF MAGNETIC SUBSTANCES

THE only substances which, in the pure state, are notably magnetic are iron, cobalt and nickel. On the other hand, the metals manganese and chromium, when in combination with certain other substances, are appreciably magnetic. The metal bismuth is peculiar; it is *diamagnetic*, that is to say, when placed in a magnetic field, bismuth produces a weakening effect on the field (see Chapter VII, § 45).

The chief characteristic quantity which defines the magnetic quality of a substance is its saturation intensity of magnetisation J_s , or, alternatively, the saturation density $4\pi J_s$. The saturation density is the limiting value of the magnetic density which the substance in the pure state can develop when all the atomic current rings are completely oriented (see Chapter II).

The density $4\pi J$, corresponding to the intensity of magnetisation J , is usually termed the "metallic magnetic density," to distinguish it from the total induction density B . As already explained in § 8, Chapter I, the relationship between the two quantities is given by

$$B = 4\pi J + H.$$

For pure iron, the saturation value of the metallic density is about 21,600, so that

$$4\pi J_s = 21,600 \text{ lines per sq. cm.,}$$

or

$$J_s = 1720.$$

If an alloy is formed of iron and another substance, the saturation value of the metallic density will be less than the value for pure iron. If the alloy contains $x\%$ of pure iron, the maximum value of the saturation density which the alloy can have is

$$\frac{x}{100} 21,600$$

Apparently, the only known exception to this rule is an alloy of

iron and cobalt (Fe_2Co) the saturation density of which is about 10% greater than that of pure iron (see Fig. 44).*

34. Iron, Steel, and Some Other Alloys of Iron

In view of the supreme industrial importance of the magnetic properties of iron and steel, a brief note on the process of manufacture and the distinguishing features of these substances may be useful.

Perfectly pure iron is not ordinarily used in practice because its properties of rapid oxidation, etc., render it unsuitable. Even electrolytic iron is not absolutely pure in the chemical sense of the term.

In the generally accepted meaning of the term, iron is an alloy of pure iron with a small percentage of other substances, viz., non-metallic elements such as carbon, sulphur, phosphorus, silicon, and metallic elements, amongst which manganese is always present, and occasionally nickel, chromium, tungsten, copper, etc. For example, the following shows the percentage of foreign substances present in an extremely pure form of industrial ingot iron known as "Armco":

Copper	0.040 per cent.
Manganese	0.025 ,, ,,
Sulphur	0.025 ,, ,,
Oxygen	0.015 ,, ,,
Carbon Monoxide	0.015 ,, ,,
Carbon	0.010 ,, ,,
Nitrogen	0.004 ,, ,,
Phosphorus	0.004 ,, ,,
Carbon Dioxide	Trace
Hydrogen	,,
Silicon	,,

The percentage of carbon present in the iron is the determining factor with regard to its structure and application and forms the distinction between pig iron (cast iron) and wrought iron. Whilst

* See also T. D. Yensen, *The Electrician*, October 15th, 1915.

molten iron only contains dissolved carbon in the form of carbides of iron, manganese, etc., the carbon in solid cold iron may be in an elementary form as an independent body (graphite) embedded in the iron, or it may be in the combined state as carbide of iron.

When an iron alloy containing a comparatively low percentage of carbon (up to about 1.8%) is rapidly solidified, or quenched at a high temperature, the greater part of the carbon remains in the dissolved state and its presence determines the hardness of the quenched iron. If the iron is solidified slowly and then allowed to cool slowly, the carbon becomes uniformly distributed throughout the mass in the free uncombined state. When the whole or the greater part of the carbon is combined with the iron, the freshly-broken fracture is white or light grey, whilst if an appreciable amount of uncombined carbon is present the fracture is a darker grey.

Iron containing from 1.7% to 2.3% of carbon together with a moderate amount of the impurities previously mentioned, is not readily cast or forged.

Two large groups of manufactured iron may be distinguished, viz., *Pig, or Cast Iron*, which is rich in carbon, and *Wrought Iron*, which contains little carbon.

Pig Iron is produced by smelting iron ore with coke in the blast furnace. The ore mixture, consisting of the ore itself and limestone addition, is fed into the furnace through the cone inlet. The molten iron is run off through a sand channel into open moulds in the sand or into cast-iron moulds in which it cools into pigs. Alternatively, it may be run off into large pans lined with refractory material and carried in the molten state into the steel works.

The process of changing pig iron into wrought iron consists in the removal of the carbon by means of oxygen. This refining or puddling process, however, not only removes the carbon, but also the manganese, phosphorus, and silicon, through oxidation. If the melting temperature is not attained during the process, the iron forms into small lumps which, when subsequently welded together, give wrought iron. If the temperature is greater than the melting temperature, the whole mass becomes molten and results in cast steel.

A comparatively high carbon content (more than about 2%) makes the pig iron hard, and pressing or drawing in the cold state is impossible.

If pig iron is heated to its melting temperature, viz., about 1100° C. to 1300° C., it changes suddenly from the solid to the liquid state without first becoming plastic and can then be cast into moulds.

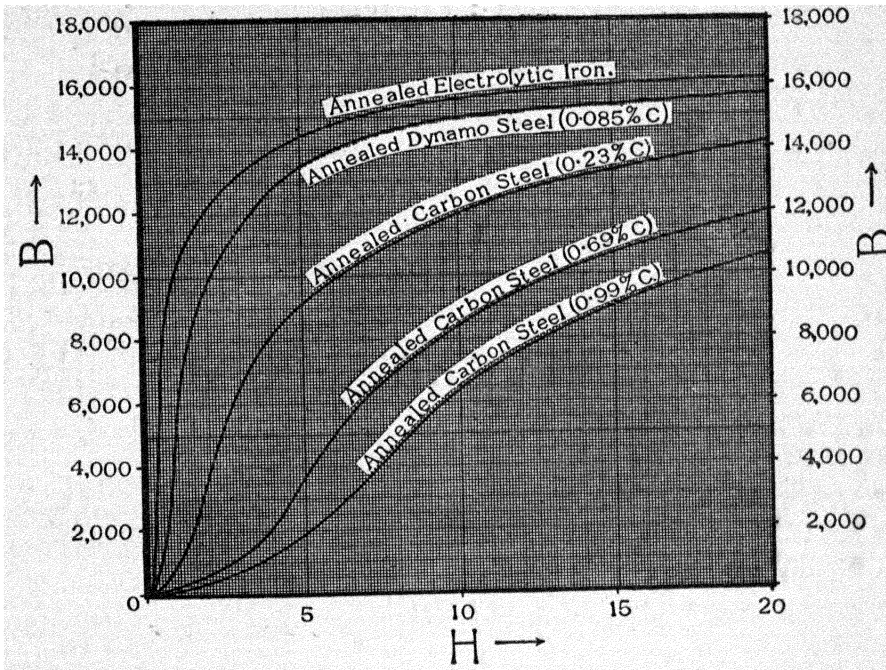

FIG. 41.

Cast iron showing a grey fracture through the presence of graphite (*i.e.*, grey or soft cast iron) can be machined. If the cast iron has been quenched so that the fracture shows light grey either throughout or at the edges, it is known as hard cast iron.

Owing to the ease with which cast iron can be made into intricate castings, it is used when practicable. Its magnetic qualities are much poorer than those of wrought iron or steel.

Malleable (or tempered) cast iron is used when the structure is required to have much better mechanical properties than ordinary

cast iron and when the castings are too small or too difficult to justify the use of cast steel. Malleable cast iron is produced by subjecting thin and light castings of special composition and showing a light grey fracture to heat treatment in contact with oxidising agents (*e.g.*, red hæmatite), and thus removing part of the carbon content.

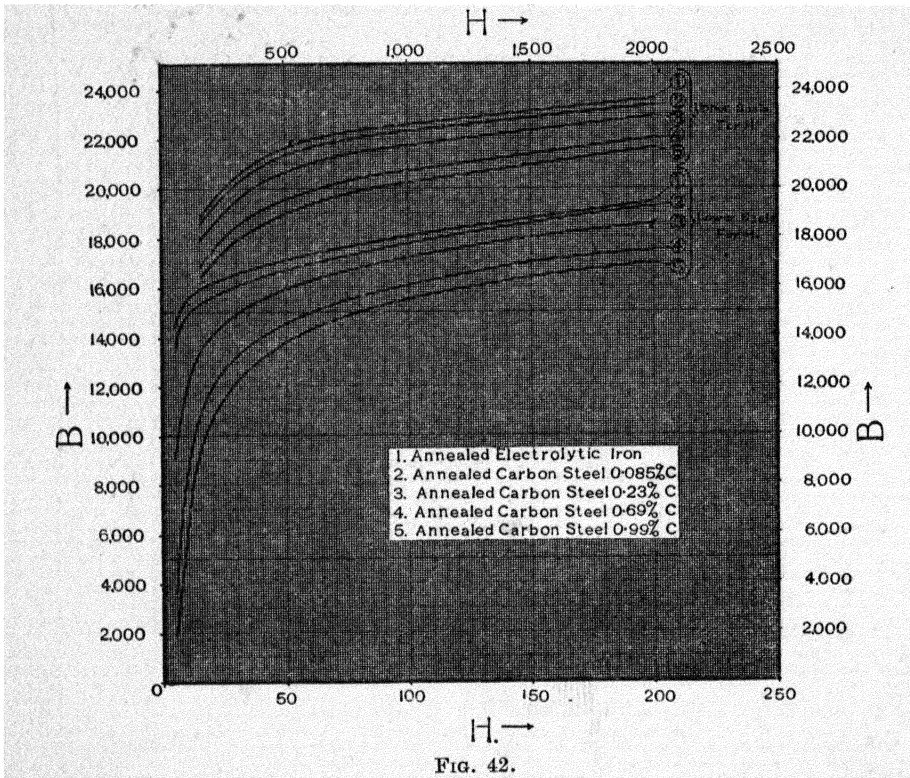

Wrought Iron melts at about 1400° C. to 1500° C. and softens gradually before becoming fluid. When hot, and to a certain extent even when cold, wrought iron is easily worked and can be given any desired form through rolling, pressing, or forging. At the correct temperature it can also be welded. When heated above the melting point it can be cast, thus giving steel castings.

Certain grades of wrought iron are commercially known as "steel," but no recognised criterion exists defining the difference

between steel and wrought iron. In general, it can be said that the grades which are rich in carbon and which can be hardened are termed *steel*, whilst the grades which are poor in carbon, up to about 0.4%, and which cannot be hardened, are termed *wrought iron* or simply *iron*.

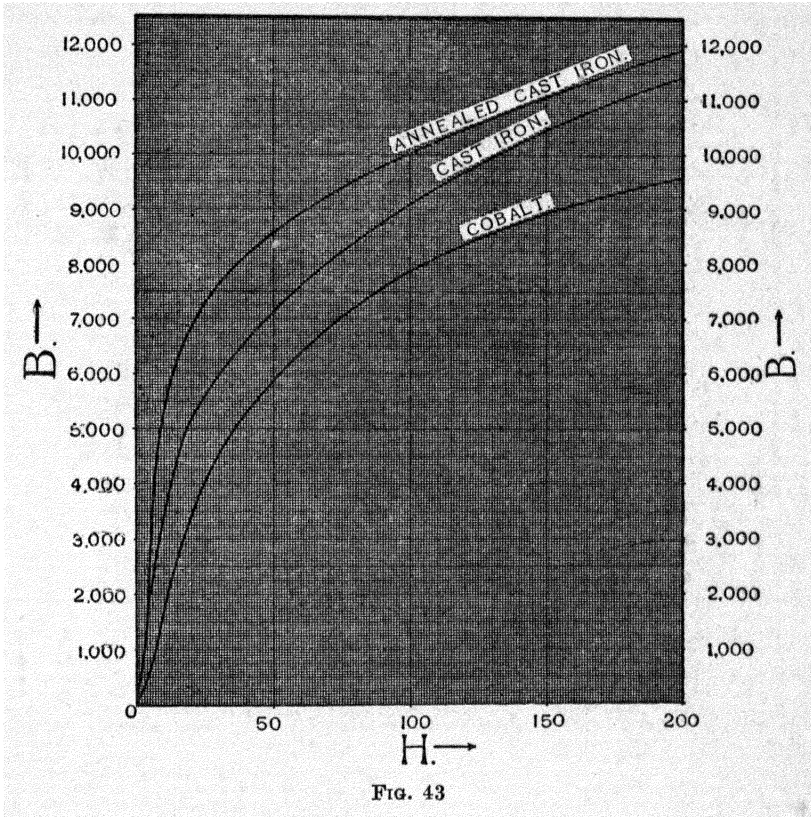

FIG. 43

In Figs. 41 and 42 are shown the $B : H$ curves for the following materials, viz. :

- (i) Annealed electrolytic iron.
- (ii) A series of annealed carbon steels with carbon content varying from 0.085% to 0.99%.

The curve referring to steel with 0.085% carbon is the usual quality for the core plates for dynamo machinery.

The steel with 0.23% carbon is the quality which would be used

for the cast steel parts of the magnetic circuit of a dynamo machine, *e.g.*, for the poles and yoke.

In Fig. 41, the values of the induction B are shown for a range of value of H from 0 to 20 gauss.

In Fig. 42, the same series of $B : H$ curves are continued to higher

values of H , viz., the lower group of curves, Fig. 42, refer to the lower scale of H and give the values for a range of H from 10 to 200. The upper group of curves in Fig. 42 refer to the upper scale for H , viz., from $H = 200$ to $H = 2000$ gauss.

It is of interest to note that for electrolytic iron when $H = 2000$ gauss, the induction

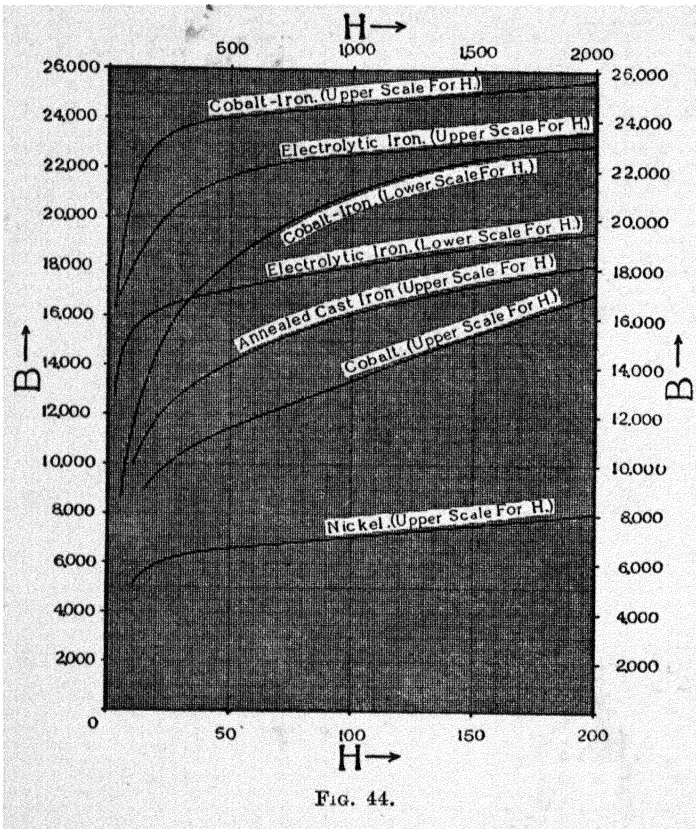

FIG. 44.

density is $B = 23,600$. At this density, the iron will be saturated and hence the value of the "metallic" saturation density is

$$B - H = 21,600 \text{ lines per sq. cm.,}$$

so that the intensity of magnetisation at saturation J_s is given by

$$4\pi J_s = 21,600$$

or

$$J_s = 1720.$$

In Fig. 43, are shown the $B : H$ curves for unannealed cast iron and for annealed cast iron, respectively, for a range of value of H from 0 to 200 gauss.

In Fig. 44, the $B : H$ curve for annealed cast iron is shown for values of H from 100 to 2000 gauss (*i.e.*, for the upper scale for H).

In Fig. 54 (page 87), the permeability of cast iron is shown as a function of the induction B .

In Fig. 44 is shown the $B : H$ curve for the iron-cobalt alloy Fe_2Co , which shows the extraordinary result that the saturation intensity of magnetisation for this alloy is considerably more than the value for pure iron. Thus, assuming that the alloy is saturated when $H = 2000$ and $B = 25,600$, it follows that the "metallic" saturation density is 23,600 lines per sq. cm., that is,

$$4\pi J_s = 23,600$$

or

$$J_s = 1880,$$

as compared with the value $J_s = 1720$ for pure iron.

Special Alloyed Silicon Steel.—For electrical engineering purposes, a steel alloyed with silicon has come into extended use. The effect of adding a small percentage of silicon to commercially pure iron is to greatly increase its specific electrical resistance and also to increase its permeability over a wide range of induction densities (*i.e.*, about up to values of $B = 13,000$), and to reduce the hysteresis loss (see Chapter I, § 15).

A well-known type of silicon steel invented by Sir R. A. Hadfield is the brand known as "stalloy," a typical composition of which is as follows:

Iron	96.20 per cent.
Silicon	3.40 „ „
Manganese	0.32 „ „
Sulphur	0.04 „ „
Carbon	0.03 „ „
Phosphorus	0.01 „ „

The $B : H$ curve for "stalloy" is given in Fig. 45 and the $\mu : B$ curve is given in Fig. 46.

One disadvantage of silicon sheet steel is that it is hard and brittle and trouble has been experienced due to cracking when bent. By reducing the percentage of silicon, this trouble may be reduced, although the characteristic magnetic properties of the silicon steel are thereby depreciated.

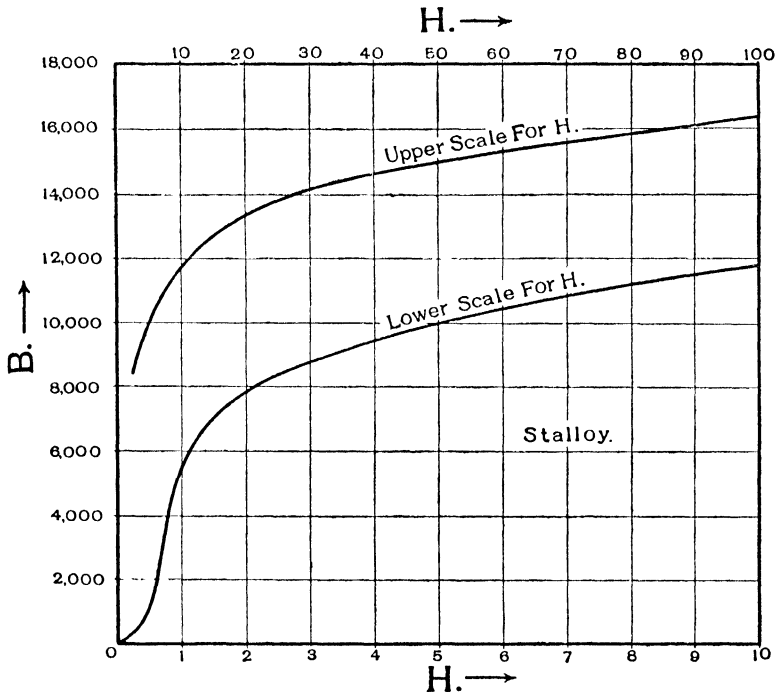

FIG. 45.

Steels Used for Permanent Magnets.—In Chapters II and III, reference has been made to the metallurgical and other properties of the various types of steels used for permanent magnets. In Fig. 47 are shown the magnetisation curves for the following representative steels of this type, viz. :

- (i) Tungsten Magnet Steel.
- (ii) Hadfield's "Permanite".
- (iii) K. S. Magnet Steel (*i.e.*, Japanese Cobalt Steel).

(iv) Cobalt Chromium Magnet Steel (see also Fig. 108, Chapter XII).

Permalloy.—Permalloy * is the name given to a series of alloys of nickel and iron containing from 45% to 80% of nickel. These alloys all possess high permeability for low fields and reach saturation

with magnetising forces less than 10 gauss. The 81% nickel permalloy reaches saturation at 4 gauss, when its intensity of magnetisation is a little more than 800, and at 1 gauss the intensity of magnetisation is 700. The hysteresis loss per c.c. per cycle at an induction of 8300 is only 350 ergs, and the hysteresis loss is only half that amount for the permalloy having 78.5% nickel.

So far, the most important commercial application of this alloy has been for the "loading" of

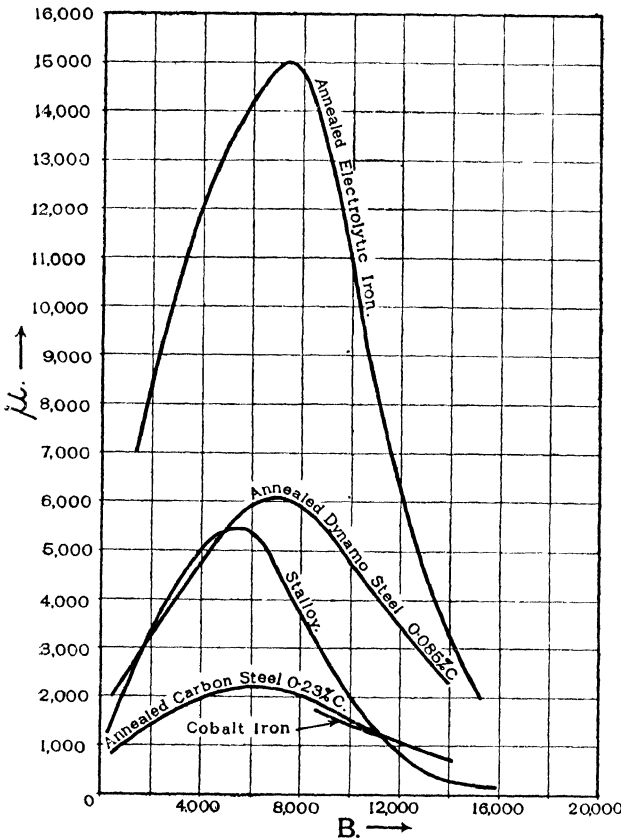
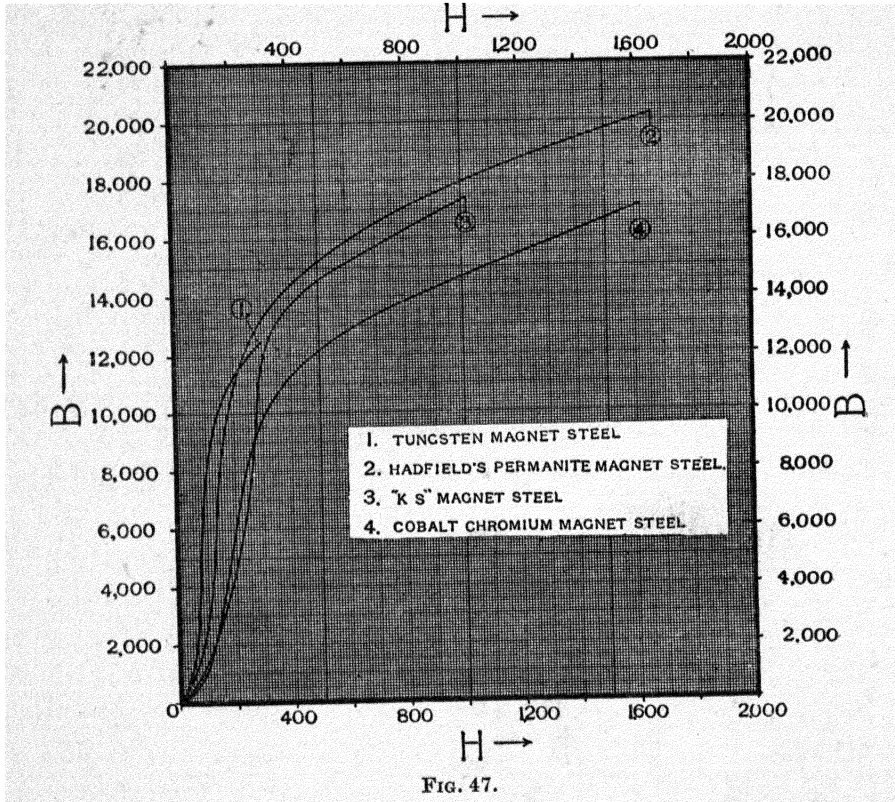

FIG. 46.

submarine telegraph cables, that is, for the purpose of providing the necessary distributed inductance which permits the cable to be worked at a high speed of signalling without distortion of the signals.

* See H. D. Arnold and G. W. Elmen, *Journal of the Franklin Institute*, 1923. Also *E.T.Z.*, October 22, 1925; O. E. Buckley and L. W. McKeehan, *Physical Review*, August 1925.

[The alloy used for this purpose consists of 78·5% nickel and 21·5% iron] These materials are of the purest commercial quality obtainable. For example, a sample of this alloy which was made from "Armco" iron, referred to above, and nickel of the proportions specified, was found on analysis to have the following approximate average composition,* viz. :



Nickel	78·23 per cent.
Iron	21·35 „ „
Cobalt	0·37 „ „
Manganese	0·22 „ „
Copper	0·10 „ „
Carbon	0·04 „ „

* See *E.T.Z.*, *loc. cit.*

Silicon	0.03 per cent.
Sulphur	0.035 „ „
Phosphorus	trace.

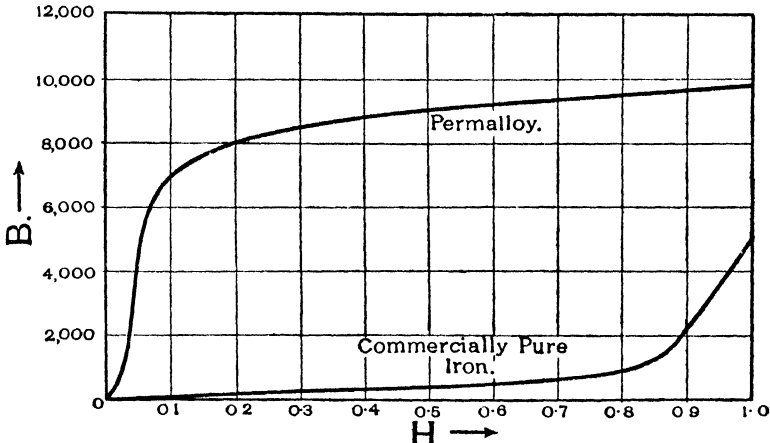

FIG. 48.

The small quantities of impurities specified in the above analysis are not serious in their effect on the magnetic properties. Variations in the heat treatment are more serious than the effect of these impurities.

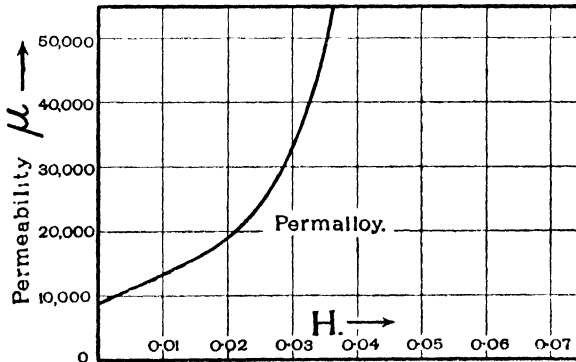

FIG. 49.

In Fig. 48 is shown the $B : H$ curve for permalloy for values of H from 0 to 1.0 gauss, and for purposes of comparison the $B : H$ curve is also given for the very pure form of commercial iron known as "Armco."

In Figs. 49 and 50 are shown the values of the permeability as a function of the magnetising force H for permalloy and "Armco" iron, respectively.

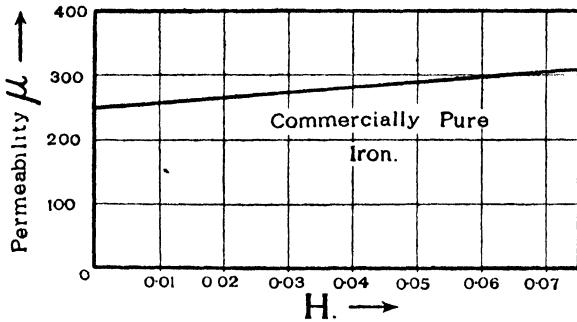

FIG. 50.

In Fig. 51 the permeability curves for permalloy and "Armco," respectively, are plotted as a function of the induction B .

Inspection of Fig. 49 brings out the characteristic property of permalloy, viz., its high permeability for low values of the magnetising force.

It is seen that the permeability reaches a maximum value of 90,000 when the value of the magnetising force H is about 0.06 gauss.

That is to say, the maximum value of the permeability for permalloy is about 300 times as large as the permeability of pure iron for the very low values of H which are met with in telegraph cable work.

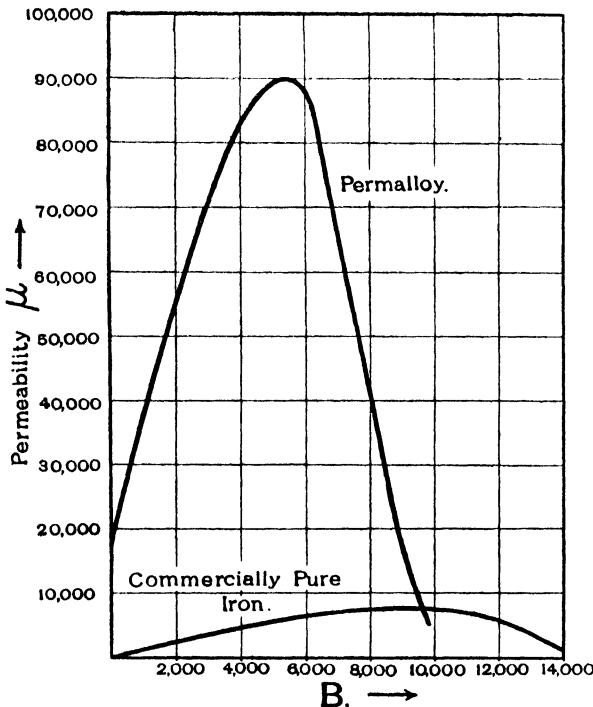

FIG. 51.

In Fig. 52 is shown a curve giving the effect of the percentage composition of an alloy of nickel and iron on the initial value of the permeability, that is, for $H = 0$. The abscissæ

initial value of the permeability, that is, for $H = 0$. The abscissæ

in Fig. 52 show the percentage of nickel in the alloy, the percentage of iron being, of course, given by subtracting the percentage of nickel from 100. Inspection of Fig. 52 shows that the curve rises very steeply and reaches a maximum when the composition of the alloy is 78·5% nickel and 21·5% iron.

In Fig. 53 is shown a hysteresis loop for permalloy for the value of the induction density $B_{\max.} = 5000$, and also in the same Fig. 53

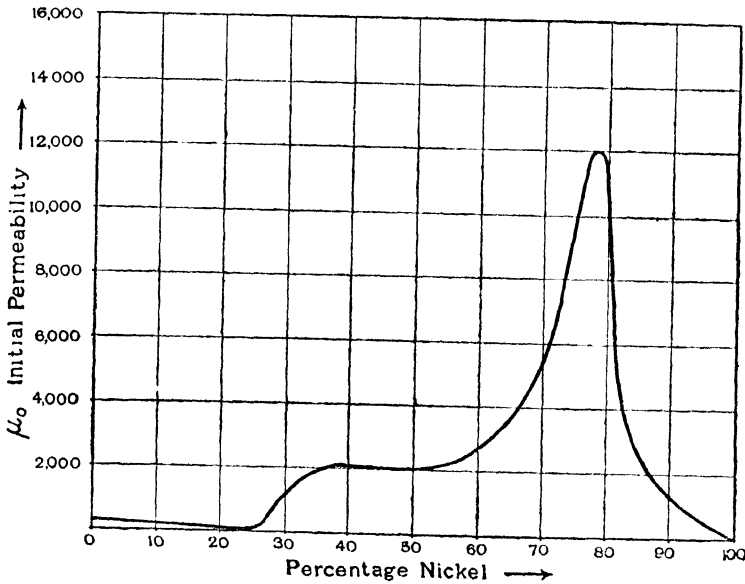

FIG. 52.

is given a hysteresis loop for pure iron (*i.e.*, “Armco” iron) for the same value of the induction density $B_{\max.} = 5000$.

[The area of the hysteresis loop for permalloy is only about one-sixteenth the area of the hysteresis loop for pure iron]

Tests have shown that, provided the limits of elasticity are not exceeded, mechanical treatment has no particular effect on the magnetic properties. Otherwise, mechanical treatment can seriously affect the value of the permeability for low values of the magnetising force H .

Temperature variations below 300° C. have little influence on the ultimate magnetic properties. However, the rate of cooling above

this temperature is of importance. The most favourable heat treatment has been found to be heating up to 900°C . and maintaining at this temperature for an hour and, having taken precautions against oxidation, cooling slowly, heating again to 600°C ., quickly removing from the furnace and placing on a copper plate and then allowing the alloy to cool down to the room temperature.

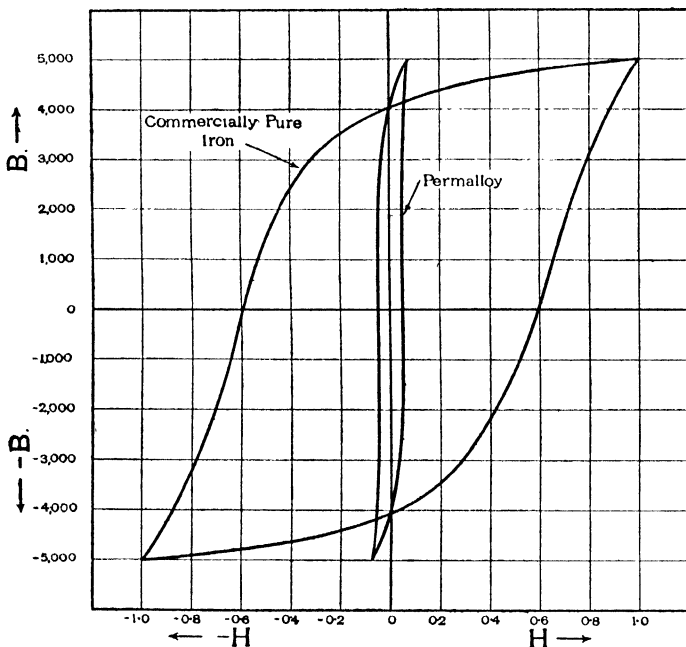

FIG. 53.

For further reference to permalloy, and a suggested explanation of its phenomenal characteristics, see Chapter VI, § 41.

Cobalt.—In Figs. 43 and 44 are given the magnetisation curves for cobalt. It will be seen that the magnetisation curve for this metal approximates to that of cast iron which is also given in the same figures. In Fig. 54, the permeability of cobalt is shown as a function of the induction B . Cobalt does not lose its magnetic properties until heated to about 1000°C ., so that for temperatures between about 800°C . and 1000°C . cobalt is the only known substance which is magnetic.

The remarkable effect of alloying cobalt with iron has already been referred to, the $B : H$ curve for an iron-cobalt alloy, Fe_2Co , being shown in Fig. 44.

Nickel.—The $B : H$ curve for nickel is shown in Figs. 55 and 44, and the permeability curve is given in Fig. 54. Nickel ceases to be magnetic at a temperature below red heat, viz., at about $360^\circ C$.

A nickel-steel containing 25% nickel may be non-magnetic or magnetic, according to whether the steel has reached the room temperature by cooling down from a red heat or by being heated up from about $-50^\circ C$.

This effect is shown in Chapter III, Fig. 39.

Manganese. — In so far as is known, pure manganese is practically non-magnetic. Numerous alloys of manganese, however, are known which have curious properties. For example, if iron is al-

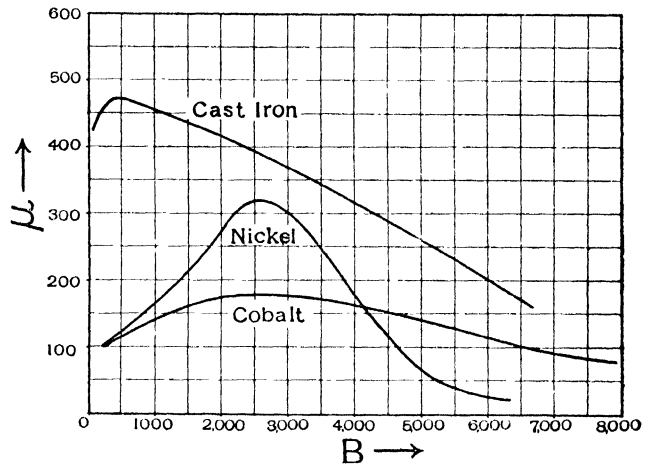

Fig. 54.

loyed with about 10% to 15% manganese, the resultant alloy is practically non-magnetic, the maximum permeability being only about 1.2 (see Fig. 56). In order to show this effect as clearly as possible, the ordinates in Fig. 56 are the values of the “metallic” magnetic density $4\pi J$.*

There are alloys of manganese with other non-magnetic metals, such alloys being appreciably magnetic. The best known of these are the Heusler alloys which were discovered by Heusler in 1903. These alloys are composed of manganese, aluminium and copper, $AlMnCu_2$. The $B : H$ curve for one such alloy is shown in Fig. 55. It has been observed that the rate at which the alloy is cooled down

* See Hadfield and Hopkinson, *Journal I.E.E.*, 1911, Vol. XLVI, p. 235.

from the molten state has a great effect on the magnetic properties. Thus if the rate of cooling is slow, the alloy is not highly magnetic. If, however, the molten metal is dropped into water the magnetic properties become most pronounced.

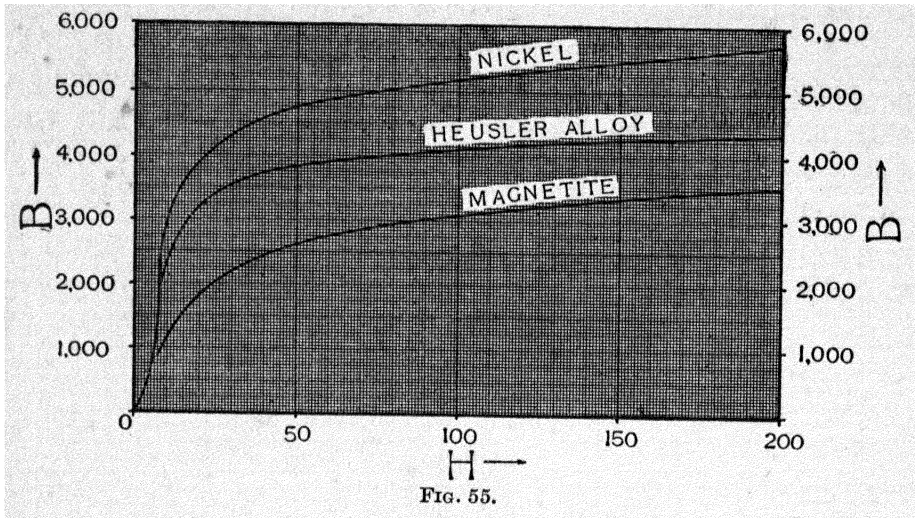

FIG. 55.

Manganese forms magnetic compounds with many other non-magnetic elements. The following is a list of a number of

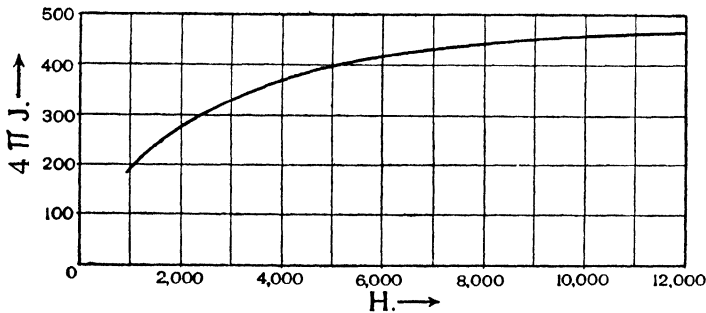

FIG. 56.

such manganese magnetic compounds: manganese and antimony; manganese and arsenic; manganese and bismuth; manganese and boron; manganese and phosphorus; manganese and tin.

From the values of the saturation density of manganese alloys it would appear that the "metallic" saturation density of pure manganese is about 30,000. This is the value as deduced from the

reluctivity relationship in Chapter V. If this is the true saturation density of manganese, it would mean that this metal is the most highly magnetic substance known.

Chromium.—This metal, when in the pure state, is, so far as is known, non-magnetic. There is no known magnetic alloy of chromium and any other non-magnetic metal. Two oxides of chromium are known, however, which are appreciably magnetic. One of these magnetic oxides is obtained when chromium trioxide is heated.

Chromium is the characteristic ingredient of “stainless steel,” the amount used being from 12% to 14%.

In the following table are given some of the leading characteristic constants of a number of magnetic materials.

TABLE.

Substance.	“Metallic” Saturation Density.*	Saturation Intensity of Magnetisation J_s .	Demagnetisation Temperature.	Atomic Weight.	Hysteresis Constant η . Average Values.
Pure Iron	21,600	1,720	765° C. 520° C. 1,075° C. About 360° C.	55.84	0.002
Swedish Wrought Iron .	21,250	1,700			
Average Sheet Steel, Annealed	20,200	1,610			
Average Soft Steel Castings	20,200	1,610			
Special Tungsten Steel .	20,300	1,620			
Average Cast Iron . . .	15,000	1,200			
Cobalt-Iron, Fe_2Co . .	22,500	1,790			
Cobalt	12,200	970			
Nickel	6,500	520			
Manganese	28,000 to 30,000 (as deduced from Mn alloys)	2,300			
Magnetite, Fe_3O_4 . . .	4,700	370	550° C.	0.020	
Heusler Alloy, $MnAlCu_2$	7,000 (highest value)	5,500	300° C.	0.020	
Manganese-Antimony Compound	7,000	5,500	300° C.	0.040	
Monel Metal	2,200	170			

* For definition of “metallic” density see page 94, also Chapter V, § 39.

35. Magnetic Viscosity

If annealed wrought iron is subjected to a magnetising force and if any change in the force occurs, some time will elapse before the corresponding change in the intensity of magnetisation is complete. This effect is termed "magnetic viscosity" and is particularly prominent when very small magnetic forces or very small changes of the magnetic force are involved. The time-lag of the intensity of magnetisation on the change of magnetising force may be so great

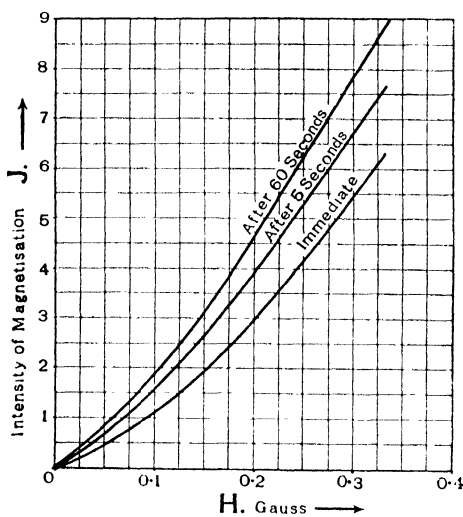

FIG. 57.

that the ballistic galvanometer method of testing (see Chapters IX and X) becomes no longer satisfactory. The magnetometer method, however, is especially suitable for detecting and measuring these effects (see Chapter XIII).

In Fig. 57, which is taken from Ewing's book on "Magnetic Induction in Iron and Other Metals," is shown the relationship between the magnetising force H and the corresponding intensity of magnetisation J for the following conditions, viz.:

- (i) When the value of J is measured immediately after the application of the magnetising force H .
- (ii) When the value of J is measured 5 seconds after the application of the magnetising force H .
- (iii) When the value of J is measured 1 minute after the application of the magnetising force H .

The measurement of J was made by means of the magnetometer.

In Fig. 58, which is also taken from Ewing's book, this phenomenon is represented in a somewhat different manner and shows how the magnitude of J creeps up with the time for the two cases in

which a steady magnetising force of 0.035 gauss and 0.081 gauss, respectively, was applied.

Further reference to this phenomenon of "magnetic viscosity" is made in Chapter V, § 40.

36. Non-magnetic Cast Iron

Recently, Messrs. Ferranti have introduced a quality of cast iron which is practically non-magnetic. The maximum value of the permeability of this material is stated to be 1.03, and it is specially suitable for parts of electrical machinery and apparatus such as the end-plates and shields for generators and motors, transformer covers, cable boxes, etc., as it can be used without the risk of developing such heavy eddy currents as would be induced if the metal were magnetic. This quality of cast iron can be supplied much more cheaply than other non-magnetic metals such as brass and aluminium.

Another characteristic feature of this material which is of great practical value is the remarkably high value of the specific resistance, viz., 140 microhms per cm. cube. This property renders it useful for resistance grids for motor controllers and other apparatus for which high-resistance units in a compact form are necessary.

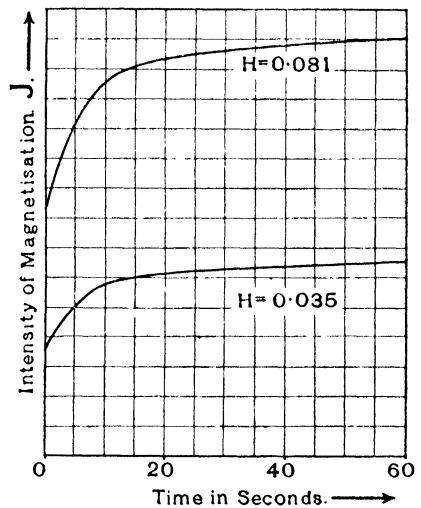

FIG. 58.

37. Measurement of Field Strength by Means of a Bismuth Spiral

If a bismuth wire is placed in a strong magnetic field which is directed at right angles to the length of the wire, the resistance of the bismuth is found to be increased, and the amount of the increase is, for a wide range of values, closely proportional to the strength of the

field. This phenomenon, which is an example of the "Hall Effect," is sometimes made use of as a means of measuring the strength of a magnetic field. Messrs. Hartmann and Braun make an arrangement for this purpose in which pure bismuth wire about 1 mm. thick is wound in the form of a flat spiral protected by mica shields. This

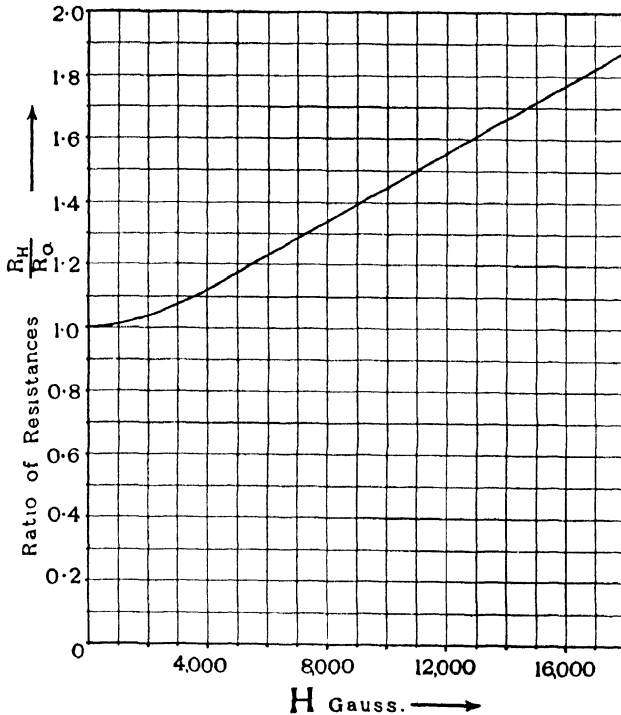

FIG. 59.

spiral can be placed, for example, in the air gap of a dynamo and by noting the corresponding change in resistance of the spiral the distribution of the flux density in the air-gap may be determined.

In Fig. 59 is shown the relationship between the strength H of the magnetic field and the corresponding value of the ratio $\frac{R_H}{R_0}$,

where R_H is the resistance of the bismuth spiral when placed in

a transverse magnetic field of strength H gauss, and R_0 is the resistance of the spiral when the field strength is zero.

It is important to note that in using this method for measuring field strengths the temperature of the spiral must not vary appreciably during the test, otherwise the change of resistance of the bismuth due to a change in temperature will obscure the results.

The specific resistance of bismuth is 119 microhms per cm. cube at 18° C. and 160.3 microhms per cm. cube at 100° C.

CHAPTER V

THE RELUCTIVITY RELATIONSHIP: THE FRÖHLICH-KENNELLY EQUATION

38. The Fröhlich Relationship

IN the year 1882, Fröhlich stated the following relationship, viz. :
The permeability is proportional to the magnetisability.

This may be expressed in symbols as

$$\mu = a(B_s - B)$$

where B is the magnetic induction

B_s „ „, saturation value of the magnetic induction,

μ „ „, the permeability,

a „ „, a constant.

The quantity $(B_s - B)$ is therefore the possible increase of induction beyond the existing induction.

Now writing

$$\mu = \frac{B}{H}$$

gives

$$B = B_s - \frac{\mu}{a} = B_s - \frac{B}{Ha}$$

or

$$B \left(1 + \frac{1}{Ha} \right) = B_s$$

$$B = \frac{B_s Ha}{1 + Ha} = \frac{H}{\frac{1}{B_s a} + \frac{1}{B_s}}$$

that is,

$$B = \frac{H}{\alpha' + \sigma' H}$$

where α' and σ' are constant, viz. :

$$\sigma' = \frac{1}{B_s}$$

$$\alpha' = \frac{1}{B_s a} = \frac{\sigma'}{a}$$

39. The Fröhlich-Kennelly Relationship

In the year 1893, Kennelly re-stated Fröhlich's relationship in another and more convenient form as follows :

Writing

$$\rho' = \frac{1}{\mu} = \frac{H}{B},$$

Fröhlich's equation becomes

$$\frac{H}{B} = \alpha' + \sigma'H$$

or

$$\rho' = \alpha' + \sigma'H,$$

where ρ' is the reciprocal of the permeability and is termed the "reluctivity."

For small values of H the product

$$\sigma'H = \frac{1}{B_s}H$$

is small (see the example given below), and the reluctivity is chiefly determined by the quantity α , which therefore determines the initial rate of rise of the magnetisation curve.

The quantity α is termed the "coefficient of magnetic hardness."

The quantity $\sigma = \frac{1}{B_s}$ is termed the "saturation coefficient."

For high values of H , the quantity $4\pi J = B' = B - H$ tends towards a definite saturation value and the quantity B' , which is the flux density due to the inherent magnetisation of the substance, is called the "*metallic magnetic density*."

Hence, writing

$$\rho = \frac{H}{4\pi J} = \alpha + \sigma H,$$

experimental data go to show that, except at very low densities, the Kennelly reluctivity equation holds for pure magnetic materials, *e.g.*, iron, nickel, cobalt, that is to say, the coefficients α and σ are strictly constant.

For impure magnetic materials such as steel, cast iron, etc., the

Kennelly relationship is not given by a single straight line for the whole range, but by one straight line for the lower range of induction values, and another straight line for the higher range of induction values. Sometimes there is a third straight line for the highest values of magnetic induction.

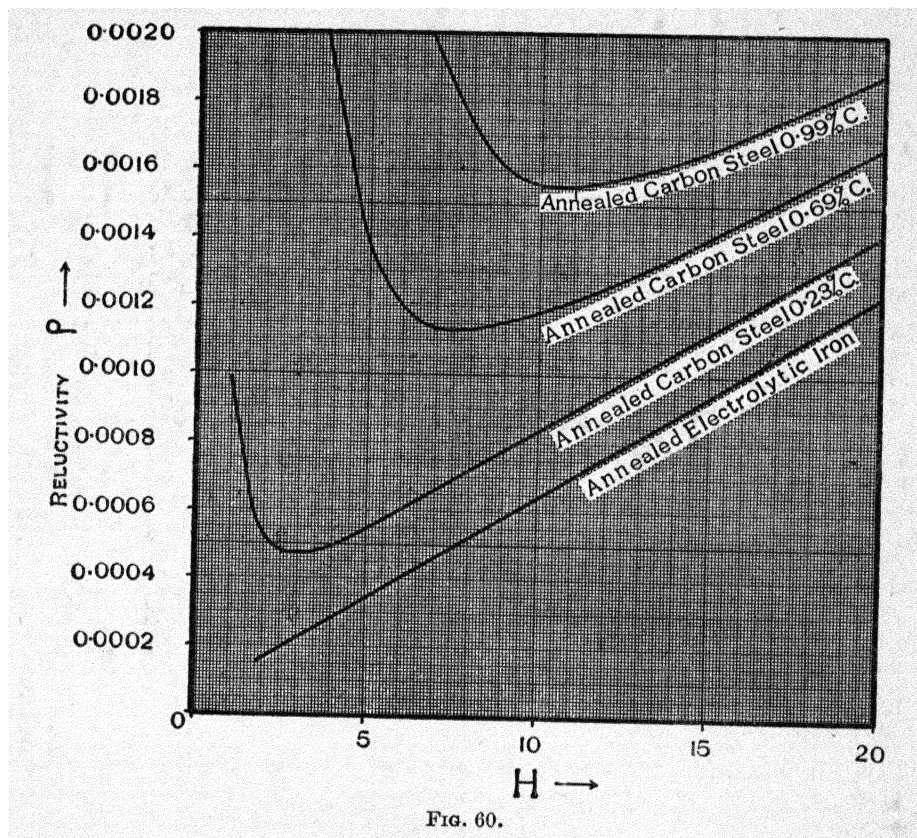

FIG. 60.

In Figs. 60 and 61 is shown the reluctivity relationship for annealed electrolytic iron for which the magnetisation curve is given in Chapter IV (Figs. 41 and 42). The relationship is represented by two distinct straight lines which intersect at the point a_1 (Fig. 61). One of these straight lines is defined by the equation

$$\rho = 0.00005 + 0.000059H$$

and it will be seen that this equation holds for values of H from 2 to 75 gauss.

The coefficient of magnetic hardness for this range of values of H is

$$\alpha = 0.00005$$

and the saturation coefficient

$$\sigma = 0.000059$$

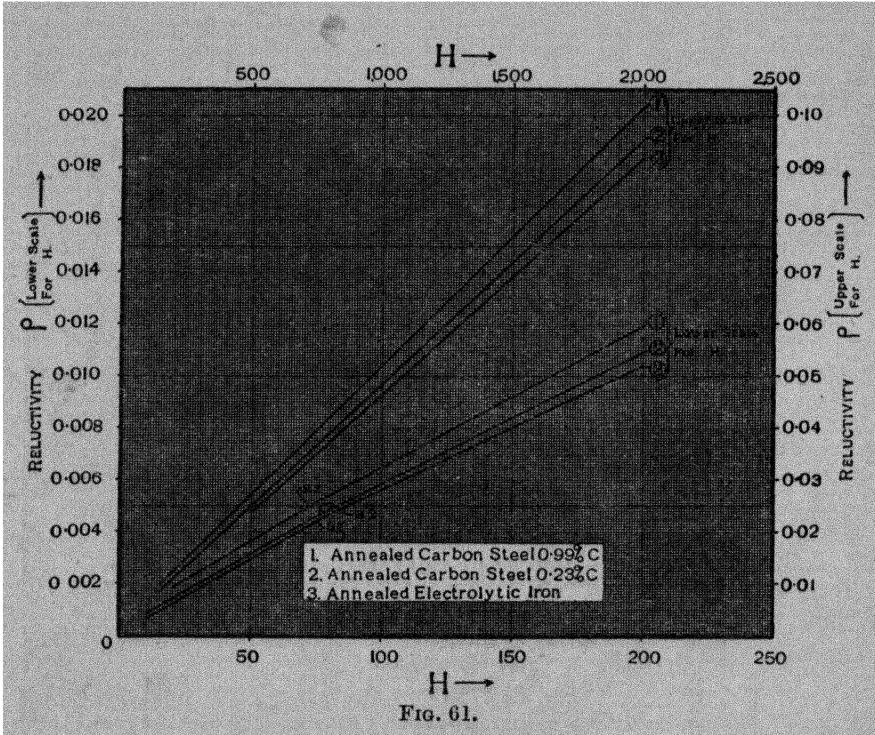

FIG. 61.

For the higher values of H , viz., from 75 to 2000 gauss, the equation of the reluctance straight line is

$$\rho = 0.0009 + 0.000045H$$

The coefficient of magnetic hardness is

$$\alpha = 0.0009,$$

and the saturation coefficient is

$$\sigma = 0.000045$$

The value of the metallic saturation induction is therefore

$$B_s = \frac{1}{\sigma} = \frac{1}{0.000045} = 22,100 \text{ lines per sq. cm.}$$

In Figs. 60 and 61 are also given the reluctivity relationship for annealed carbon steel having respectively 0.23%, 0.69%, and 0.99% carbon content.

In Fig. 61 the reluctivity relationships for the steels having 0.23% and 0.99% carbon, respectively, are also shown for the higher ranges of H up to 2000 gauss.

For example, the reluctivity for annealed carbon steel having 0.23% carbon is given by two separate straight lines, which intersect at the point a_2 (Fig. 61). For the lower values of H , viz., from 5 to 75 gauss, the equation of the straight line is

$$\rho = 0.00025 + 0.000059H$$

The coefficient of magnetic hardness for this range is

$$\alpha = 0.00025,$$

and the saturation coefficient is

$$\sigma = 0.000059$$

For values of H from 75 to 2000 gauss, the reluctivity is given by the straight line

$$\rho = 0.0009 + 0.00005H,$$

the coefficient of magnetic hardness for this range being

$$\alpha = 0.0009,$$

and the saturation coefficient

$$\sigma = 0.00005$$

The metallic saturation induction for this steel is therefore

$$B_s = \frac{1}{\sigma} = \frac{1}{0.00005} = 20,000 \text{ lines per sq. cm.}$$

In Fig. 62 is shown the reluctivity relationship for cobalt as deduced from the magnetisation curve given in Figs. 43 and 44. Two distinct straight lines are again required to express the reluctivity for the whole range of H . For the lower values of H , viz., from 30 to 58 gauss, the equation of the straight line is

$$\rho = 0.0038 + 0.000094H.$$

The coefficient of magnetic hardness for this range of H is therefore

$$\alpha = 0.0038,$$

and the saturation coefficient

$$\sigma = 0.000094$$

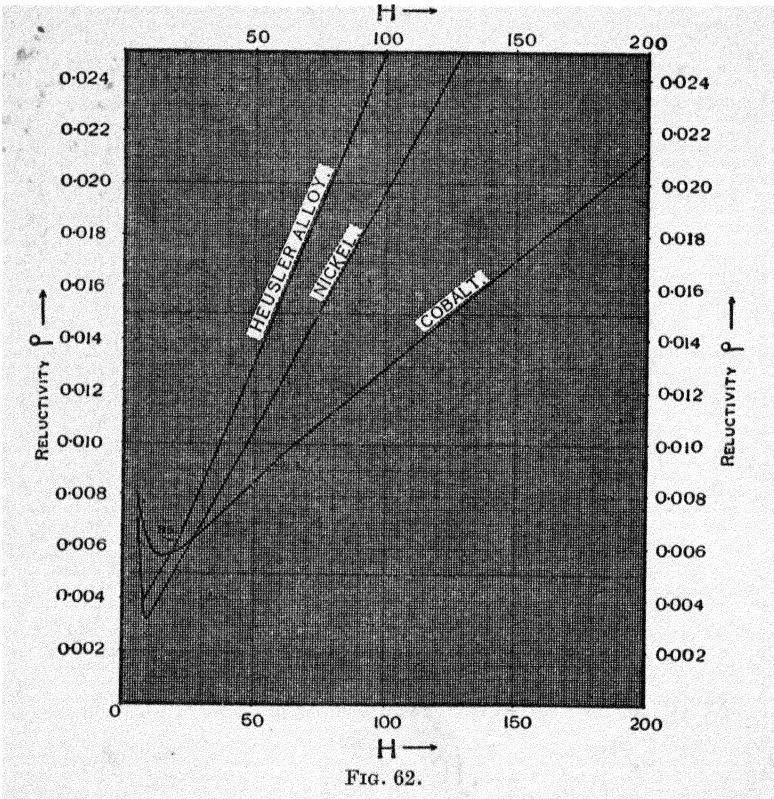

For the higher range of H , viz., from 60 to 200 gauss, the straight line is represented by the equation

$$\rho = 0.0046 + 0.000083H,$$

the coefficient of magnetic hardness being

$$\alpha = 0.0046,$$

and the saturation coefficient

$$\sigma = 0.000083$$

The saturation value of the metallic induction density is

$$B_s = \frac{1}{\sigma} = \frac{1}{0.000083} = 12,000 \text{ lines per sq. cm.}$$

In Fig. 62 are also shown the reluctivity relationships for nickel and the Heusler alloy as deduced from the respective magnetisation curves given in Chapter IV, Figs. 44 and 55.

40. General Remarks on the Reluctivity Straight Line

A peculiar feature of the reluctivity relationship is the upward bend of the reluctivity ρ for low values of H . This appears to exist for all materials and the full significance of it has not yet been satisfactorily explained.

It is of interest, however, to reconstruct the $B : H$ curve for the low values of H on the assumption that the reluctivity straight-line equation holds for these low values of H also.

In Fig. 63 the full-line curve shows a portion of the magnetisation curve for annealed carbon steel (0.23% C), the reluctivity relationship for which is shown in Fig. 60. The dotted curve in Fig. 63 shows the magnetisation curve that would be obtained if the straight-line portion of the reluctivity relationship given in Fig. 60 were to be produced as a straight line to cut the ordinate axis, that is to say, assuming there were no bend in the reluctivity line of Fig. 60.

There is an interesting fact which should be noted in connection with the curves given in Fig. 63. If the $B : H$ curve is taken by the method of reversals and also by the "step-by-step" method (see Chapter X), the "step-by-step" method gives a $B : H$ curve

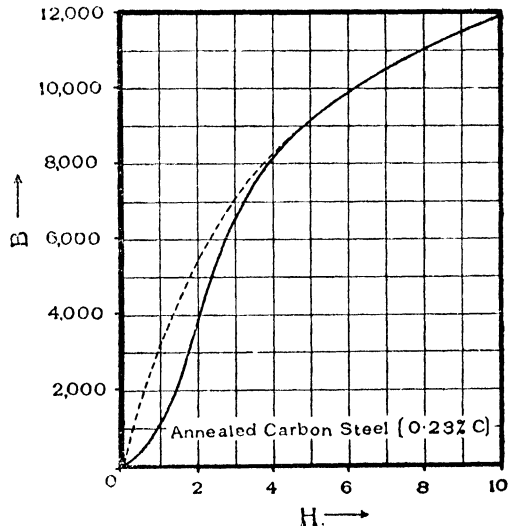

FIG. 63.

which will lie above that obtained by the method of reversals. The latter curve (*i.e.*, the lower curve) is not stable, and if a given value of H is maintained for some time, the value of B will gradually creep up towards the value given by the "step-by-step" method for that value of H . It thus appears that the magnetisation curve as obtained by the "step-by-step" method gives a reluctivity relationship which is more nearly a straight line for the low values of H than would be the case if the magnetisation curve were taken by the method of reversals.

There is yet another peculiarity to observe in connection with these phenomena, *viz.*, if, whilst the $B:H$ curve is being taken, the material is being continually passed through a cyclic magnetic change, say, by means of an alternating current producing a magnetic flux at right angles to the ballistic test flux, the $B:H$ curve so obtained tends towards the value shown by the dotted curve in Fig. 63. Since, however, the alternating-current magnetic flux cycle is at right angles to the path of the ballistic test flux, there will be no cutting of the search coil by the alternating-current flux. The effect of the alternating-current magnetic flux is to maintain the molecules of the iron in a state of continual disturbance.

When the material is a mixture of a magnetically soft substance and a non-magnetic hard substance, then at low values of H the soft substance will carry most of the flux and the density rises rapidly, giving a low value for α , but an apparently low value for the saturation coefficient S . At higher values of H the harder material carries more flux and the increase of the flux in the soft material is less owing to its approach to the saturation value. The saturation value of the substance thus increases and the hardness is greater. The changes in the reluctivity have been artificially produced by J. D. Ball, who has combined, by superposition, two different materials which separately gave straight-line reluctivity relationships, but in combination showed the characteristic breaks in the straight line.

CHAPTER VI

MAGNETO-STRICTION: EFFECT OF MECHANICAL STRESS ON MAGNETISATION

THE subject of the interdependence of mechanical stress and magnetic characteristics is one of very great interest and importance. In the present chapter it is only possible to refer to some of the

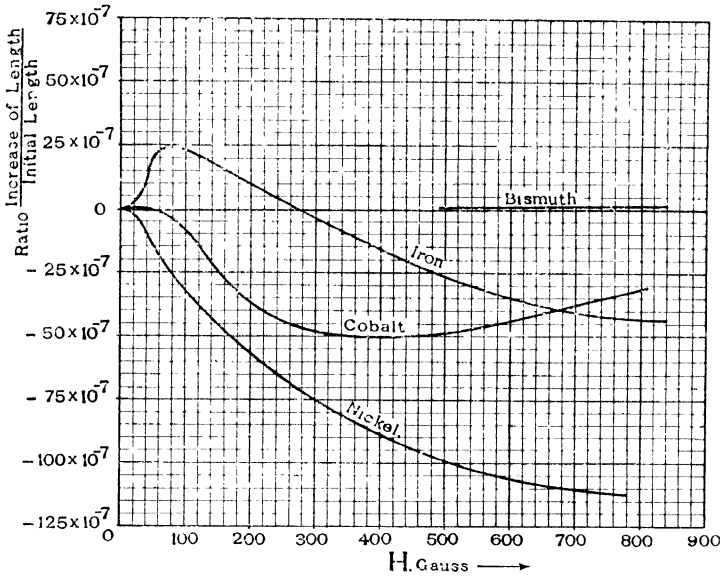

FIG. 64.

leading facts and to emphasise the importance of further research in this direction. For further detailed and extended information, the reader is referred to Ewing's treatise.*

41. Effect of the Magnetisation of a Bar on its Length (Magneto-striction)

Joule appears to have been the first to observe that a bar of iron changes its length when magnetised. Bidwell † carried out a large number of exact researches on this subject and some of his results are

* J. A. Ewing, "Magnetic Induction in Iron and Other Metals."

† See Shelford Bidwell, *Proc. Roy. Soc.*, Vol. XL, 1886: Vol. XLVII, 1890.

given in Figs. 64, 65 and 66. In Fig. 64, the results are given for iron, cobalt, nickel and bismuth, respectively, the range of the magnetising force being from 0 to 800 gauss. In Fig. 65, the curves are given for values of H up to 1400 gauss. In Fig. 66 is shown the effect of magnetisation on the length of a bar of iron when the iron is subjected to mechanical loading.

i. *Iron*.—Referring to Fig. 64, it will be seen that for values of the magnetising force H between 0 and about 270 gauss the effect

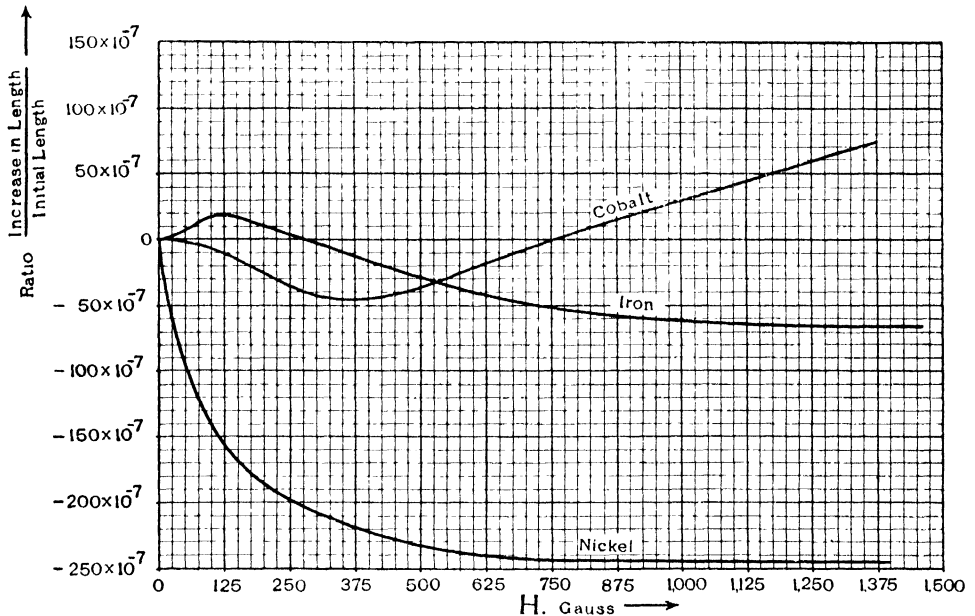

FIG. 65.

of magnetising the rod is to increase its length. The maximum lengthening effect occurs when the magnetising force is about 80 gauss and the maximum amount of lengthening is about 2.5 parts in a million. If the magnetising force is increased to about 270 gauss, there is neither lengthening nor shortening of the rod. For values of the magnetising force greater than about 270 gauss the effect of magnetising the rod is to shorten it.

In Fig. 65 is shown the effect of increasing the magnetising force up to about 1400 gauss, and it will be observed that the

maximum amount of shortening of the rod becomes 6.5 parts in a million.

In Fig. 66 is shown the effect of magnetising a soft annealed iron wire when the wire is simultaneously subjected to a tensile stress. The change in length of the wire is shown as a function of the magnetising force. Each of the curves shown refers to a different value of the tensile stress, the respective values of the tensile stress

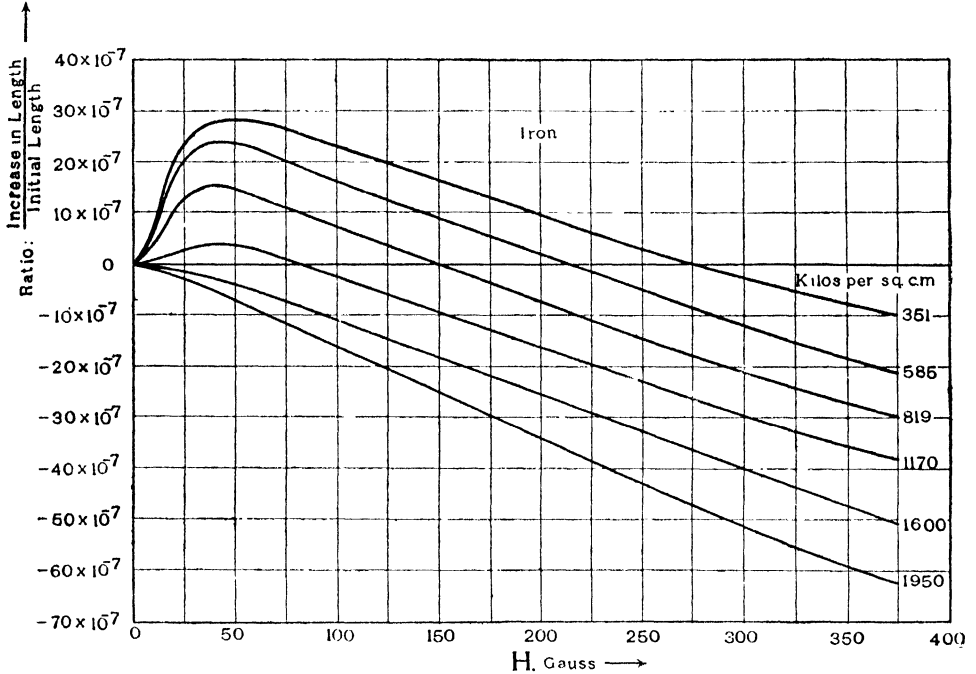

FIG. 66.

being stated below in kgms. per sq. cm. and, for convenience, the equivalent stresses in lbs. per sq. in. are also stated.

Stress in kgms. per sq. cm.	Stress in lb. per sq. in.
351	4,960
585	8,300
819	11,600
1,170	16,500
1,600	22,600
1,950	27,600

ii. *Cobalt*.—The effect on the length of a rod of cobalt due to magnetisation is greatly different from that of an iron rod. Referring to Fig. 64, it appears that for values of H between 0 and about 50 gauss, the rod very slightly increases in length when magnetised. When magnetised by stronger fields, the rod shortens and for magnetising forces in the neighbourhood of 400 gauss the amount of shortening becomes a maximum, being then about 5 parts in a million. For stronger fields (see Fig. 65), the amount of shortening decreases until when H is equal to about 750 gauss the change in length of the rod is zero. For magnetising forces greater than 750 gauss a rod of cobalt increases in length when magnetised.

iii. *Nickel*.—This metal behaves in a manner different from either iron or cobalt. As seen in Figs. 64 and 65, magnetising a nickel rod causes it to decrease in length for all values of the magnetising force. It is further to be noted that the actual magnitude of the change in length of a nickel rod due to magnetisation is very much greater than for either iron or steel, reaching as much as nearly 25 parts in a million.

iv. *Bismuth*.—The change in length of a rod of bismuth when magnetised is extremely small, the results obtained by Bidwell being shown in Fig. 64.

The phenomenon of change of length of a rod when magnetised is termed “magneto-striction.”

In a recent paper,* L. W. McKeehan gives an interesting explanation of the remarkably high permeability of “permalloy” (see Chapter IV, § 34, Fig. 49), based on magneto-striction effects.

It is suggested that in every ferro-magnetic substance the process of magnetisation consists of two parts, viz., (i), changes which occur wholly within the single atoms, such changes being termed *intra-atomic* changes, and (ii) changes which involve more than one atom and therefore may be termed *inter-atomic* changes.

The intra-atomic changes are assumed to be governed by quantum

* See L. W. McKeehan, *Physical Review*, Second Series, Vol. XXVI, No. 2, August 1925.

dynamics and the principal changes in the magnetic moment of any individual atom are to be considered as being abrupt. The abrupt change in the magnetic moment of an atom is accompanied by a change in that atom which is independent of the environment in which it is placed. This change affects the forces which the atom exerts on its neighbours so that the body of which it is a part tends to change its dimensions. The nature of the change in the forces which takes place may be inferred from the change in the over-all dimensions of bodies of measurable size and which consist wholly of atoms of the kind considered. The atomic change which must occur to explain the total magneto-striction of a body is termed atomic magneto-striction.

Another assumption is that magnetic hardness and hysteresis are due primarily to inter-atomic stresses set up by atomic magneto-striction and therefore are dependent, not only on the type of atom which is magnetised, but also on the mechanical properties of the particular piece of metal of which it forms a part. In magnetically hard materials, the changes involved in atomic magneto-striction meet great resistance and require large amounts of energy to be supplied to the atoms through the application of strong magnetic fields. In magnetically soft materials, the same changes meet with little resistance and can be produced, therefore, by means of weaker magnetic fields.

As already explained, permalloy as used in practice is composed of 78.5% nickel and 21.5% iron, and it has been found by McKeehan that the magneto-striction effect of a nickel-iron alloy changes sign when the percentage of nickel is about 81.

Now nickel shortens when longitudinally magnetised, and for small values of the magnetising force iron lengthens. It is therefore to be expected that in these alloys local stresses which may be set up by the magnetisation of a nickel atom will be partly relieved by the magnetisation of an adjacent iron atom, and conversely. Magnetisation of a properly proportioned alloy of this type should become magnetised to saturation by a weak magnetising field. The proper proportion of nickel and iron should be such that the magneto-

striction of the resulting alloy should vanish. Hysteresis in this alloy will be small, because there is simultaneous magnetisation of small groups of nickel and iron atoms in such proportion that the changes in the forces exerted by the group upon its neighbours is a minimum. The remanence will be high, because no considerable unrelieved strains will ever exist during the process of magnetisation. Since the interatomic forces will be but little modified during the entire process of magnetisation, the effect of crystalline structure in such an alloy should be unimportant, and this is actually found to be the case.

Permalloy has been tested in the form of wires 0.1 cm. in diameter and 60 cms. long in a solenoid nearly as long, by reversal of the field and measurement of the induction through a search coil wound over the middle of each wire and in series with a ballistic galvanometer. When these wires are subjected to tension, saturation is reached within 5% for fields so low as 0.1 gauss and the hysteresis loss per c.c. per cycle reduced to 80 ergs.

42. Effect of Mechanical Stress on the Magnetisation of Iron

It was discovered by Matteucci that if a bar of magnetised iron is stretched, its magnetisation is thereby increased. This effect was further investigated by Villari, who found that Matteucci's result only holds if the bar is weakly magnetised. If the bar is strongly magnetised, the effect of stretching is to decrease the magnetisation. In other words, there is a certain critical value for the magnetising force such that stretching the bar has no effect on its magnetisation. If the magnetising force is *below* this critical value, stretching the bar *increases* the magnetisation. If the magnetising force is *above* this critical value, stretching the bar *decreases* the magnetisation.

Stretching a bar of magnetised iron thus affects the magnetisation and the effect reverses in direction as the magnetising force passes through the critical value. This reversal phenomenon is known as the "Villari Reversal."

The effect of mechanical strain on the magnetisation is reciprocal

to the effect of magnetisation on the length of a bar of iron as referred to in § 41. Thus :

Effect of Magnetisation on the Length.	Effect of Mechanical Strain on the Magnetisation.
A weakly magnetised bar of iron becomes increased in length due to the magnetisation.	Stretching a weakly magnetised bar of iron increases its magnetisation.
A strongly magnetised bar of iron decreases in length due to magnetisation.	Stretching a strongly magnetised bar of iron decreases its magnetisation.

These effects are further illustrated in Fig. 67. Two magnetisation curves are shown for a steel wire rope, viz., (i) for the case in which the rope is unloaded, (ii) for the case in which the rope is subjected to a tensile stress of 51,000 lb. per sq. in. It will be observed that for values of the magnetising force below about $H = 65$ gauss the loaded rope has a much higher permeability than the unloaded rope. For values of the magnetising force greater than about 65 gauss, the permeability of the loaded rope is less than that of the unloaded rope.

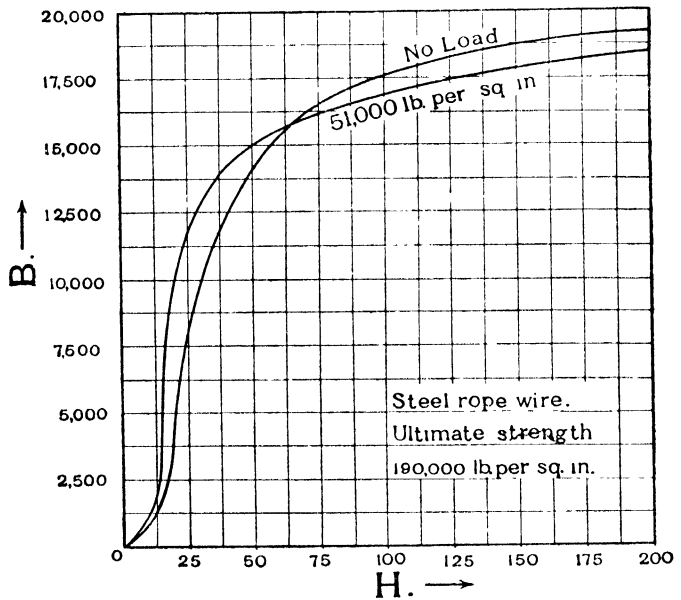

FIG. 67.

for values of the magnetising force below about $H = 65$ gauss the loaded rope has a much higher permeability than the unloaded rope. For values of the magnetising force greater than about 65 gauss, the permeability of the loaded rope is less than that of the unloaded rope.

In Fig. 68, the $\mu : B$ curves are shown for the loaded and the unloaded rope, respectively, and have been deduced from the magnetisation curves of Fig. 67. It will be seen, for example, that for

an induction of about 10,000 lines per sq. cm., loading the rope to a stress of 51,000 lb. per sq. in. has the effect of increasing the permeability by as much as 50%.

The effect of loading is still further illustrated in Fig. 69, in which is shown as a function of H the increase or decrease of induction density ΔB due to the loading for two values of the tensile stress, viz., 51,000 lb. per sq. in., and 127,000 lb. per sq. in.

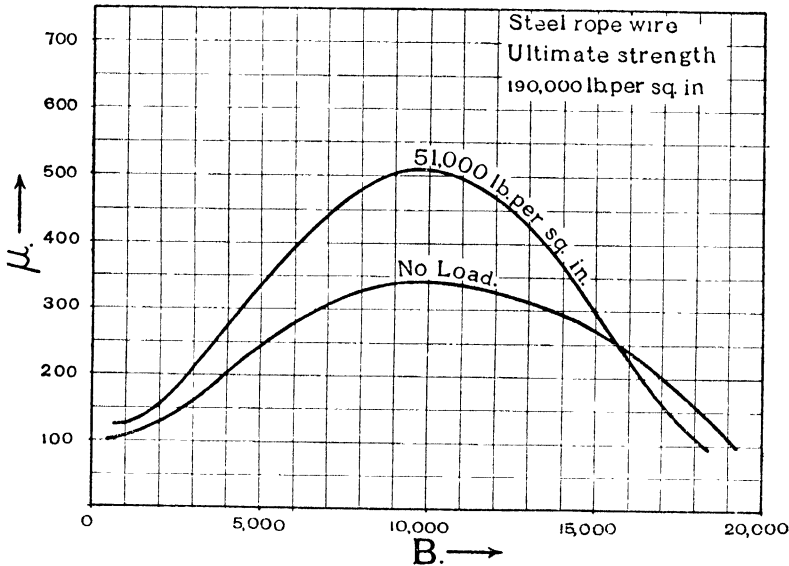

FIG. 68.

It will be seen that, for the particular load of 51,000 lb. per sq. in., the critical value of H is about 65 gauss, in the neighbourhood of which magnetising force the Villari reversal takes place. If H is less than about 65 gauss, a tensile stress of 51,000 lb. per sq. in. on the rope increases the magnetisation, and if H is greater than about 65 gauss, the specified tensile stress causes a diminution in the magnetisation. When the same rope is loaded so that the tensile stress is 127,500 lb. per sq. in., the critical value of H , in the neighbourhood of which the Villari reversal takes place, is about 35 gauss.

In Fig. 70, the effects are shown in still another form, viz., the increase or diminution of the induction density ΔB is shown as a

function of the tensile stress for a series of values of the magnetising force H . Thus for the Villari reversal to occur at a value of about $H = 20$ gauss, a tensile stress of about 135,000 lb. per sq. in. will be necessary. If the Villari reversal is to occur at the higher value of $H = 75$ gauss, the tensile stress would have to be reduced to about 40,000 lb. per sq. in.* (see also, Chapter XVI, § 85).

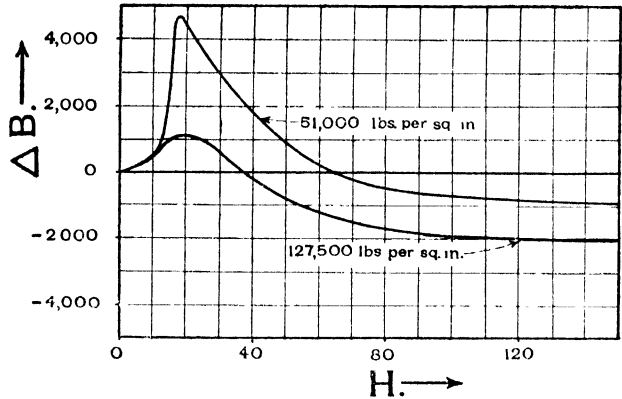

FIG. 69.

43. Effect of Torsion on the Magnetisation of a Wire

The first recorded results of the relationship between torsion and the magnetisation of an iron wire are those of G. Wiedemann.

Suppose that an iron wire is carrying an electric current which flows in the direction of its length. This current will produce a magnetic force in a direction which is perpendicular to the axis of the wire. That is to say, the lines of magnetic force are circles in planes perpendicular to the axis, there is thus no magnetisation produced in the wire in the direction of its length. Wiedemann found, however,

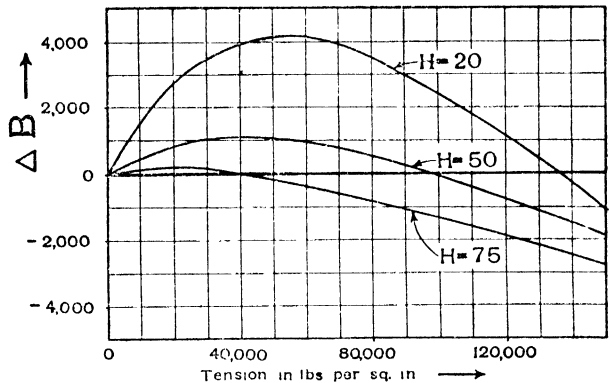

FIG. 70.

* See R. L. Sanford, *Electrical World*, August 15th, 1925, p. 309.

that if the wire were twisted whilst the current is flowing, the wire becomes magnetised in the direction of its length. This result can be explained in the light of the results already given in § 42.

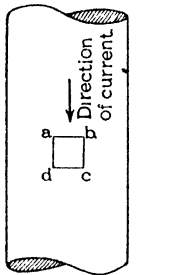

FIG. 71.

Suppose, for example, that Fig. 71 shows a portion of an iron wire vertically suspended and that a current is passed down the wire. Consider a small square $abcd$ on the surface of the wire. If the lower end of the wire is now twisted in a direction from right to left as shown by the arrow, the square $abcd$ will be distorted so that the diagonal bd becomes lengthened and the diagonal ac shortened. Now in accordance with the phenomena explained in § 42, if the magnetising force is relatively weak, as it will be in the case under consideration (that is,

unless the current in the wire is made excessively strong), stretching

causes an increase of permeability, whilst shortening causes a decrease of permeability. The actual magnetising force H is in a direction at right angles to the axis of the wire (see Fig. 72A). This force H may be resolved into a component H_{bd} along the diagonal bd and a force H_{ca} along

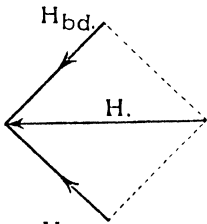

FIG. 72A.

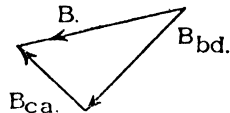

FIG. 72B.

the diagonal ca . Since, however, the diagonal bd is lengthened, due to the twist in the wire, and the diagonal ac is shortened, it follows that the induction B_{bd} along bd is greater than the induction B_{ca} along the diagonal ca , as shown in Fig. 72B. The resultant induction B is therefore directed downwards. That is to say, the wire will become magnetised in a longitudinal direction, and for the direction of current shown and the direction of twist specified in Fig. 71, the lower end of the wire will become a N pole.

The reciprocal of this effect is also true, viz., that if the wire is, say, suspended vertically and magnetised longitudinally, and if a current is sent along the wire in an axial direction, the lower end of the wire will twist.

CHAPTER VII

THE ELECTRON THEORY OF MAGNETISM

44. Magnetic Classification of Substances

ACCORDING to their magnetic characteristics, practically all substances may be arranged in one of three classes, as follows :

(i) *Diamagnetic Substances*, which, when placed in a magnetic field, become (weakly) magnetised in a direction opposite to that of the field. To this class belong bismuth, sulphur, water, alcohol, zinc, copper, silver, gold, mercury, etc.

(ii) *Paramagnetic Substances*, which, when placed in a magnetic field, become weakly magnetised in the same direction as the field. This class comprises oxygen, air, manganese, chromium, platinum, etc.

(iii) *Ferromagnetic Substances*, which, when placed in a magnetic field, become strongly magnetised in the same direction as the field. These substances are characterised by the fact that a weak field produces a strong magnetisation in them, and to this class belong iron, steel, cobalt, nickel.

In the present chapter the modern electron theory of magnetism will be outlined, according to which the magnetic characteristics of substances are accounted for by the arrangement of the electronic orbits in the atoms of the substance.

More than 100 years ago Ampère suggested that every particle of a magnetic substance has closed currents circulating about it in the same direction. Before magnetisation, the molecules lie in different directions, and hence the molecular currents show no resultant magnetic effect at points outside the substance. When subjected to an impressed magnetic field, however, the molecules become turned with their molecular current axes more or less in the same direction and their magnetic effects reinforce each other and thus become apparent at points outside the substance.

The discovery of the electron and the development of the electron theory of matter has now placed Ampère's remarkable speculation on a firm foundation of experimental fact.

45. Electron Theory of Diamagnetism

In Fig. 73, an electron is shown in its orbit revolving in a *counter-clockwise* direction. This electron (which is a negative quantity of electricity), revolving in a counter-clockwise direction, is equivalent to a current flowing in a *clockwise* direction in a circular conductor of the orbital radius r . A magnetic field due to the revolving electron will consequently be established in a direction perpendicular to the plane of the paper and directed away from the observer through the plane of the paper.

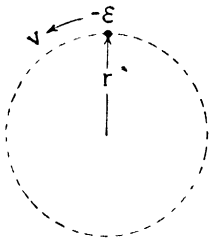

FIG. 73.

If m is the mass of the electron, in grams,
 ϵ ,, electric charge of the electron in electrostatic units,
 v ,, velocity of the electron, in cms. per second,
 c ,, ratio of the magnitude of the electro-magnetic unit of electrical quantity to the electrostatic unit that is $c = 3 \times 10^{10}$.

The time of one revolution of the electron will be

$$T = \frac{2\pi r}{v} \text{ seconds.}$$

Now consider the magnetic moment of this revolving electron, that is, the moment of the magnet to which it is equivalent.

Suppose in Fig. 74 a uniform magnetic field of intensity H gauss is impressed in a direction *parallel* to the plane of the orbit.

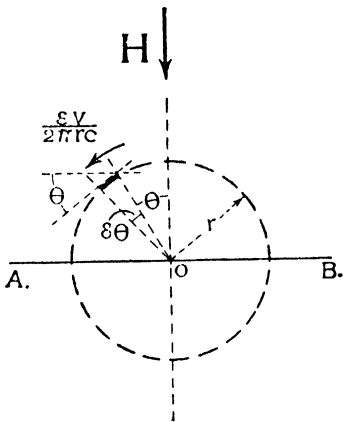

FIG. 74.

The revolving electron will be equivalent to a current of the value

$$i = \frac{\epsilon v}{2\pi r c} \text{ electro-magnetic units.}$$

The force exerted on an element $r\delta\theta$ of the length of the path will be

$$f = H \frac{\varepsilon v}{2\pi r c} r\delta\theta \cos \theta \text{ dynes.}$$

Hence the moment of the couple acting on this element and tending to turn it about the axis AB will be

$$fr \cos \theta = \frac{H\varepsilon v \cos^2 \theta r\delta\theta}{2\pi c} \text{ dyne-cms.}$$

The moment of the couple acting on the whole circle of the orbit will be

$$\begin{aligned} & 2 \int_{-\frac{\pi}{2}}^{+\frac{\pi}{2}} \frac{H\varepsilon v \cos^2 \theta r d\theta}{2\pi c}, \\ &= \frac{H\varepsilon v r}{\pi c} \int_{-\frac{\pi}{2}}^{+\frac{\pi}{2}} \left(\frac{H \cos 2\theta}{2} \right) d\theta \\ &= \frac{H\varepsilon v r}{2c} \text{ dyne-cms.} \end{aligned}$$

If M is the magnetic moment of the magnet which is equivalent to the revolving electron, the couple on such a magnet will be

$$MH.$$

Hence,

$$MH = \frac{H\varepsilon v r}{2c}$$

or

$$\begin{aligned} M &= \frac{\varepsilon v r}{2c} = \frac{\varepsilon \omega r^2}{2c} \\ &= \frac{\varepsilon r^2 \pi}{cT} \text{ in electro-magnetic units,} \end{aligned}$$

where

$\omega = \frac{v}{r}$ is the angular velocity of the electron in radians per sec.

and

$T = \frac{2\pi}{\omega}$ sec. is the periodic time of the electron.

Now suppose that there is impressed on the electronic orbit (Fig. 73) a magnetic field directed away from the observer and perpendicular to the plane of the orbit. There will then act on the electron two forces, viz. :

- (i) A radial force tending to increase the radius r ,
- (ii) Whilst the impressed magnetic field is being established, there will be a force tending to slow down the electron, that is, to reduce v .

It can be shown that the change in r will be extremely small as compared with the change in v , and in the following the change in r will be taken to be negligibly small.

The flux through the orbit at any moment t due to the impressed field will be

$$\phi = \pi r^2 H$$

where H is the intensity of the impressed field at the moment t .

Hence an e.m.f. e will be induced in the electronic orbit such that

$$e = - \frac{d\phi}{dt} = - \pi r^2 \frac{dH}{dt}$$

The work done on the electron during one revolution will be

$$w = \frac{\epsilon e}{c} = - \frac{\epsilon \pi r^2}{c} \frac{dH}{dt} \text{ ergs}$$

The force acting on the electron in a direction tangential to the orbit is

$$\begin{aligned} f &= \frac{w}{2\pi r} = - \frac{\epsilon \pi r^2}{2\pi r c} \frac{dH}{dt} \\ &= - \frac{\epsilon r}{2c} \frac{dH}{dt} \text{ dynes} \end{aligned}$$

$$\therefore \frac{dv}{dt} = \frac{f}{m} = - \frac{\epsilon r}{2mc} \frac{dH}{dt} \text{ cms. per sec. per sec.}$$

The change in magnetic moment corresponding to this reduction in speed of the electron is

$$\frac{dM}{dt} = \frac{r\epsilon dv}{2cdt} = - \frac{\epsilon^2 r^2}{4mc^2} \frac{dH}{dt} \text{ in electro-magnetic units.}$$

The total change in the magnetic moment of the electron during the establishment of the impressed field is

$$\int_0^T \frac{dM}{dt},$$

where T is the time taken for the establishment of the impressed magnetic field.

That is, the total change in the magnetic moment will be

$$\begin{aligned} \Delta M &= - \int_0^T \frac{\varepsilon^2 r^2}{4mc} \frac{dH}{dt} \\ &= - \frac{\varepsilon^2 r^2}{4mc^2} \int_0^T \frac{dH}{dt} \end{aligned}$$

If the impressed field rises from an initial value of zero to the value H_1 after T seconds,

$$\Delta M = - \frac{\varepsilon^2 r^2}{4mc^2} H_1 \text{ in electro-magnetic units.}$$

If several electrons are revolving in an atom and if, for example, some of the electrons revolve in the opposite direction to others, the resultant magnetic moment of the atom may vanish. The change in the magnetic moment due to the impressed field will become evident as a negative susceptibility, that is,

$$\Delta M = - \frac{\varepsilon^2 H_1}{4mc^2} \Sigma r^2 \text{ in electro-magnetic units,}$$

where Σr^2 denotes the summation of r^2 for all the electrons.

EXAMPLE.—Suppose that the impressed field reaches a magnitude of one million gauss, that is,

$$H_1 = 10^6$$

Assume that the time of one revolution of the electron is

$$T = \frac{1}{10^{15}} \text{ seconds (see § 46).}$$

The ratio

$$\frac{\varepsilon}{cm} = 1.77 \times 10^7 \text{ electro-magnetic units.}$$

Then for the case of an atom in which there is an effective current of one revolving electron,

$$\begin{aligned} \frac{\Delta M}{M} &= - \frac{2\varepsilon^2 r^2 H_1}{4mrv\varepsilon c} \\ &= - \frac{\varepsilon r H_1}{2mcv} = - \frac{\varepsilon}{mc} \frac{H_1 T}{4\pi} \\ &= - \frac{1.77 \times 10^7 \times 10^6}{4\pi \times 10^{15}} = - 0.0014 \end{aligned}$$

This result shows that for the case considered, viz., for an atomic current due to one revolving electron, the change in the magnetic moment due to impressing a magnetic field of the very high intensity of *one million gauss* is only about

$$0.14\%$$

In order, therefore, to effect any marked changes in the electronic orbits extremely high values of the impressed magnetic field are necessary.

46. Electron Theory of Paramagnetism

It has been shown in § 45 how the phenomenon of diamagnetism may be accounted for on the electronic theory if it be assumed that in the atom of a diamagnetic substance the electronic orbits are so disposed that their resultant effect is zero at points outside the atom, that is to say, the resultant magnetic moment of the atom is zero.

In the case of a paramagnetic substance it is assumed that the electronic orbits are such that the revolving electrons produce a resultant effect at points outside the atom, that is, the atom has a resultant magnetic moment.

In the following, a brief account of the theory originally formulated by Langevin for paramagnetic gases will be given, and also the modifications introduced by P. Weiss and others for the case of paramagnetic solid substances.

I. *A Paramagnetic Gas.*—In the kinetic theory of gases it is assumed that the molecules of any gas are independent of each other's

action until they collide. The effect of collisions is to impart to the molecules the same mean energy in each degree of freedom.

When a magnetic field is impressed on a paramagnetic gas, the molecules begin to turn about such axes that their electronic planes would eventually be brought perpendicular to the direction of the impressed field. The mutual collisions of the molecules, however, will abstract some of the kinetic energy so acquired from the impressed magnetic field, and will distribute it among the molecules in the form of kinetic energy of rotation about other axes and kinetic energy of translation. Consequently, the energy supplied to the gas by the impressed magnetic field will be partly converted into heat energy. The condition of equilibrium will eventually be reached such that the tendency for the molecules to set themselves with their magnetic axes in the direction of the magnetic field is balanced by the tendency of the molecular collisions to make them set themselves equally in all directions. When this state of equilibrium is reached, the conversion of the energy of the impressed magnetic field into heat energy will stop.

The determination of the equilibrium condition so reached was assumed by Langevin to be a problem similar to that of finding the density of a gas acted on by gravity. Starting from this assumption, let

- J_s be the saturation intensity of magnetisation of the gas,
- J ,, the intensity of magnetisation of the gas actually obtained when the condition of equilibrium is reached,
- H ,, the intensity of the impressed magnetic field, in gauss,
- T ,, the absolute temperature,
- α ,, Boltzmann's constant, viz., 2.06×10^{-16} ,
- N ,, the number of molecules in 1 c.c. of the gas, at 0° and 760 mm.

then it may be shown that,

$$\frac{J}{J_s} = \left(\coth \beta - \frac{1}{\beta} \right)$$

where

$$\beta = \frac{J_s H}{N \alpha T}$$

If β is small, that is, if the magnitude of the impressed field H is small, then

$$\frac{J}{J_s} = \frac{\beta}{3} \text{ approximately,}$$

or

$$\frac{J}{J_s} = \frac{J_s H}{3\alpha T N}$$

The magnetic susceptibility (§ 8) is therefore

$$\kappa = \frac{J}{H} = \frac{J_s^2}{3\alpha T N}$$

or

$$\kappa T = \frac{J_s^2}{3\alpha N} = \text{constant.}$$

This relationship was found by Curie to hold for *oxygen* and some other substances.

For the case of *oxygen* gas the value of the susceptibility is $\kappa = 1.59 \times 10^{-7}$ at a temperature of 15°C. and a pressure of 760 mm. and

$$N = 2.56 \times 10^{19} \text{ (see below).}$$

Therefore,

$$\begin{aligned} J_s &= \sqrt{\kappa T 3\alpha N} \\ &= 0.85 \text{ in electro-magnetic units.} \end{aligned}$$

If it be assumed that the magnetic moment of a molecule of oxygen gas is due to a single electron revolving with a periodic time T at a radius r , then

$$J_s = M_s = \frac{N\varepsilon}{c} \left(\frac{\pi r^2}{T} \right) \text{ in electro-magnetic units (see § 45),}$$

since the magnetic moment of saturation per c.c., M_s , is the same as the saturated intensity of magnetisation, J_s .

Therefore

$$T = \frac{N\varepsilon}{c} \frac{\pi r^2}{J_s} \text{ second.}$$

Now there are 60.6×10^{22} molecules in 1 gram-molecule of any gas. Further, 1 gram-molecule of any gas at 15° C. and a pressure of one atmosphere has a volume of 2.36×10^4 c.c. Hence, the number of molecules in 1 c.c. of gas at 15° C. and under a pressure of one atmosphere is

$$N = \frac{60.6 \times 10^{22}}{2.36 \times 10^4} = 25.6 \times 10^{18}$$

Since the magnitude of the charge ϵ is 4.77×10^{-10} electrostatic units, the value of the periodic time of the electron is

$$T = \frac{25.6 \times 10^{18} \times 4.77 \times 10^{-10}}{3 \times 10^{10} \times 0.85} \times \pi r^2.$$

Assuming that the radius of the orbit of the single electron is

$$r = 1.4 \times 10^{-8} \text{ cm.}$$

The periodic time of revolution of the electron is then

$$0.3 \times 10^{-15} \text{ second.}$$

The peripheral velocity of the electron will be

$$v = \frac{2\pi r}{T} = 29.8 \times 10^7 \text{ cm. per second,}$$

that is,

$$v = 1850 \text{ miles per second.}$$

II. *A Paramagnetic Solid Substance.*—Solid substances differ from gases by reason of the fact that neighbouring molecules of a solid exert very great forces on each other, and it is necessary to take account of these mutual molecular actions in applying Langevin's theory.

When considering the case of a paramagnetic gas, the quantity $N\alpha T$ appears in the expressions obtained. This quantity is the kinetic energy of the molecules in 1 c.c. of the gas, and it is this kinetic energy which limits the extent to which the molecules will be able to turn with their magnetic axes in the direction of the impressed magnetic field.

In the case of a solid substance, it may be considered that the

mutual actions of the molecules on each other are additional obstructions to their tendency to turn under the action of the impressed field, and can be taken into account by adding a term Z to the kinetic energy $N\alpha T$. In this way, the formula derived for the case of a paramagnetic gas becomes applicable to a solid paramagnetic substance.

The expression for the susceptibility then becomes

$$\kappa = \frac{J_s^2}{3(\alpha T N + Z)}$$

or

$$\kappa(T + z) = \frac{J_s^2}{3\alpha N}$$

where

$$Z = z\alpha N$$

Both Z and z are constants independent of the temperature.

This relation is found to hold for a number of solid substances at low temperatures.

III. *Ferromagnetic Substances.*—The behaviour of ferromagnetic substances presents many outstanding difficulties in the attempt to account for their behaviour by the electron theory outlined in the foregoing.

The extraordinary and baffling fact is that at temperatures above the critical temperature, but well below the melting point, ferromagnetic substances become paramagnetic (see Chapter III).

If T_1 is the critical temperature and T some higher temperature, P. Weiss has given the following relationship for ferromagnetic substances at temperatures above the critical temperature :

$$\kappa(T - T_1) = \frac{J_s^2}{3\alpha N}$$

For values of T which are well removed from T_1 , this relationship gives a reasonably good approximation to the experimental facts.

The question arises as to how the remarkable behaviour of ferromagnetic substances below their critical temperature is to be accounted for, that is, the high magnetisation which they show for low values of the magnetising force H .

This problem is one which has given rise to much speculation. K. Honda considers that the difference between paramagnetic and ferromagnetic substances is to be accounted for by the differences in the rotational kinetic energy of their respective molecules. He believes that in paramagnetic substances the molecules are endowed with a relatively large kinetic energy of *rotation* and that this produces a gyroscopic action which presents great resistance to their orientation by the impressed magnetic field. In the case of ferromagnetic substances below the critical point, he considered that the rotational kinetic energy of the molecules is relatively small and the consequent resistance to orientation under the influence of the impressed magnetic field is correspondingly small.

47. Diamagnetic Effect also occurs in Paramagnetic and Ferromagnetic Substances

When paramagnetic and ferromagnetic substances are subjected to an impressed field there will be two opposing effects during the establishment of the impressed, viz. :

- (i) A displacement of the electronic orbits which will correspond to a *diamagnetic* effect.
- (ii) The orientation of the molecules themselves which will produce the *paramagnetic* effect.

The actually observed susceptibility will thus be the nett result of these two opposing effects.

In the case of ferromagnetic substances below the critical temperature, the magnetisation effect due to the orientation of the molecules will, for those values of H met with in ordinary normal practice, be overwhelmingly greater than the diamagnetic effect due to the disturbed electronic orbits.

48. The "Magnetron" of P. Weiss

The magnetic susceptibility of a substance may be written in the form (see also § 46)

$$\kappa = \frac{J_e^2}{A} \left(\frac{1}{T + z} \right)$$

where z is zero for a paramagnetic gas,

„ „ is a positive number for a solid paramagnetic substance,

„ „ is a negative number for a ferromagnetic substance tested at temperatures above the critical temperature.

„ A is a numerical constant.

If this expression is plotted with κ and $\left(\frac{1}{T + z} \right)$ as co-ordinates,

a straight line should be obtained passing through the origin.

P. Weiss made a number of measurements of the susceptibility for magnetite at temperatures above the critical temperature, and found that, instead of obtaining a straight line through the origin, a series of straight lines was obtained which were separated by definite jumps in the values of κ at certain temperatures. These definite jumps appear to denote sudden changes in the value of M , the magnetic moment of the electronic orbit. The values of M which were found to correspond to these various lines in the series were all very approximately whole multiples of the number

$$18.54 \times 10^{-22}$$

On measuring the susceptibility for other paramagnetic substances, Weiss found that the value of M was always very closely equal to a whole multiple of this same number 18.54×10^{-22} . He therefore concluded that the difference between the molecules of different paramagnetic substances lies in the number of uncompensated electronic orbits.

An uncompensated electronic orbit of the moment

$$18.54 \times 10^{-22} \text{ electro-magnetic units}$$

is termed by Weiss a "magnetron."

Referring to the expression given in § 44 for the magnetic moment of a rotating electron, viz.,

$$M = \frac{\epsilon r^2 \pi}{cT},$$

and putting this equal to the moment of a magneton, then

$$\frac{\epsilon r^2 \pi}{cT} = 18.54 \times 10^{-22}$$

or

$$T = 0.5 \times 10^{-14}$$

for

$$r = 1.4 \times 10^{-8}$$

The order of magnitude for the periodic time is therefore comparable with that given in § 46.

Whether the magnetons are to be identified with the electronic orbits, or whether they are to be considered as elementary magnets arranged in the atom in parallel or in single file, does not appear to be clear as yet.

According to Perrin, in order that the magnetons may account for the frequency of the hydrogen lines in the Ritz model as well as giving the moment of 18.54×10^{-22} for the single magneton, the length of the magneton should be of the order 10^{-10} cm., that is, about one-hundredth part of the radius of the atom.

Parson has suggested that the electron itself may be *an anchor ring* of negative electricity revolving in its plane about its centre at a high velocity, and on this assumption he has built up a magneton theory of matter. Such an anchor ring electron would, of course, be equivalent to a minute magnet.

CHAPTER VIII

THE GENERATION OF VERY INTENSE MAGNETIC FIELDS

IN Chapter VII, a brief account has been given of the widely accepted view of the electron theory of magnetism. It is known that each atom of matter comprises a number of electrons rotating round a central nucleus—each rotating electron being equivalent to a current circuit and consequently produces a magnetic field within the atom. In the strongly magnetic substances, such as iron, cobalt and nickel, the fields due to the electronic circuits account for the fact that these substances are capable of being strongly magnetised. The fact that the great majority of substances are only very feebly magnetic is apparently due to the various electronic circuits in the atom being so arranged as to more or less neutralise each other's effect, so that the magnetic field which is measurable outside the substance is merely the small balance resulting from this differential effect.

It appeared to the author that if this view of the source of the magnetism of magnetic substances is well-founded, it might be possible, by means of artificially produced magnetic fields impressed on the atoms of the material, to disturb the electronic orbits by the mutual action of the impressed field and the current circuits to which the revolving electrons are equivalent.

The chief difficulty arising in attempting to carry out such an experiment is to obtain artificially magnetic fields of an intensity sufficiently great to be comparable with the inherent magnetic fields within the atom itself.

The order of magnitude of the inherent magnetic fields has been considered in Chapter VII. It was there pointed out that in order to change the magnetic moment of a revolving electron by so little as 0.1% would require an artificially impressed field of the strength of about 700,000 gauss.

Now to produce artificially magnetic fields of the strength of 700,000 gauss is by no means easy.

The author has devised a method * for the purpose of generating very intense magnetic fields, and by means of which magnetic fields of the order of half a million gauss have been generated. Much stronger fields can be generated by the device, if the power of the apparatus is suitably increased.

The question arises as to the method whereby any marked disturbance of the electronic orbits could be detected. The answer to this question seemed to lie in the fact that any marked disturbance of the electronic structure of a magnetic substance like iron would produce a corresponding change in the magnetic properties of the substance. For instance, the permeability might be expected to be altered.

The substance which is being used for the first experiments is the silicon-iron alloy known as "stalloy" (see Chapter IV, § 34).

49. Theory of the Author's System for Generating Very Intense Magnetic Fields

The basic idea of the method for producing very intense magnetic fields is that since the heat generated by a current of i amperes flowing for a time of t seconds in a conductor of resistance R ohms is

$$i^2Rt \text{ joules,}$$

it follows that if the time t be sufficiently small, it is possible to pass an indefinitely large current through the conductor without fusing it.

Now if a solenoid is wound with w turns per cm. length, the intensity of the magnetic field generated at the central part within the core is

$$H = k \frac{4\pi}{10} iw \text{ gauss,}$$

where k is a correction coefficient depending on the dimensions of the solenoid. If the solenoid is of very great length as compared

* See T. F. Wall, *Journal of the Institution of Electrical Engineers*, July, 1926, Vol. LXIV, No. 355, p. 745.

with its diameter, the value of k is very approximately equal to unity. The actual value is

$$k = \frac{2b}{4d} \log_e \frac{(a+d) + \sqrt{(a+d)^2 + b^2}}{(a-d) + \sqrt{(a-d)^2 + b^2}}$$

where a cms. is the mean radius of the solenoid winding,
 $2d$,, ,, radial depth of the solenoid winding,
 $2b$,, ,, length of the solenoid.

For further reference to this matter, see Chapter IX, § 53.

If, therefore, the magnitude of the current is made sufficiently large, the intensity of the magnetic field may be increased indefinitely. Suppose, for example, that a long solenoid is wound with 40 turns per cm. length and it is required to obtain a magnetic field of intensity 10^6 gauss at the central part within the core of the solenoid. The current necessary to produce this field will be

$$i = \frac{10^7}{4\pi w} = 19,900 \text{ amperes.}$$

If the solenoid is wound with, say, No. 16 s.w.g. wire, the normal current-carrying capacity of which is about 13 amperes, it is clear that the current of about 20,000 amperes can only be permitted to flow for a very small fraction of a second if the solenoid winding is not to be burned out.

In order, therefore, that the two essential requirements should be fulfilled, viz. :

(i) That very large currents should be generated in the solenoid winding; and

(ii) That these currents should only be allowed to flow for a very small fraction of a second,

the author decided to use the oscillatory discharge of electrostatic condensers of high capacity and charged to a high potential difference.*

The condensers used in the first tests were paper-insulated, oil-immersed, power type, as supplied by the British Insulated and

* P. Kapitza has described (*Proc. Roy. Soc.*, 1924, **A**, Vol. CV, p. 691) a method of producing intense magnetic fields by means of the discharge of accumulators.

Helsby Cables, Ltd. These condensers were supplied in units of a nominal value of 50 microfarads each, and each unit was capable of standing a charging pressure of 2000 volts direct current.

↳ The condensers are charged by means of a small 20 watt generator in series with a high voltage battery so that the total d.c. pressure available is about 2200 volts. The generator and battery in series are connected to the condensers through a very high resistance which prevents an abnormal rush of current at the initial stages of the charging process.

· The condensers require several minutes to charge to the full voltage. They are then discharged through the solenoid winding, the discharge being completed in a very small fraction of a second.

The process, therefore, is analogous to filling a reservoir through a small supply pipe and then emptying the reservoir with great suddenness by breaking down the retaining wall. In other words, the energy accumulated over a relatively long period of charging is suddenly released, with the result that an enormous power becomes available for a short interval of time. In the case of the condenser discharge, this means that an enormous current strength is obtained in the solenoid.

· The solenoid, through the core of which the very intense magnetic fields are to be produced, is immersed in oil. The oil serves the several purposes of, (i) maintaining the insulation between neighbouring turns of the solenoid in a sound condition, (ii) keeping the solenoid winding cool, (iii) acting as a buffer to the enormous mechanical forces developed between neighbouring turns of the solenoid when the very heavy discharge currents flow in the winding.

Although magnetic fields of the strengths produced by this method are very much more intense than any artificial magnetic fields hitherto produced (so far as the author is aware), they are of a strength which is small as compared with that of the magnetic fields inherent within the atom.

A single application of such artificial magnetic fields, therefore, cannot be expected to produce any marked disturbance of the electronic orbits. It appeared, however, to be reasonable to expect

that a repeated application of the magnetic fields of the order of magnitude of 10^6 gauss might produce an appreciable disturbance of the electronic orbits by a cumulative process, just as a repeatedly applied small mechanical stress in a metal can eventually break down the molecular structure of the metal although a single application of the stress may not produce any noticeable effect.

Included in the system, therefore, is an automatic switch by means of which the magnetic field may be applied an indefinitely large number of times.

The factor which governs the rate at which the condenser discharges may be allowed to occur is the heating of the solenoid winding. Time must be allowed for the heat generated at the interior of the winding to dissipate through to the oil, otherwise the solenoid winding will very soon break down.

An interesting effect becomes prominent when dealing with currents of the very large magnitude which are developed with large capacity condenser discharges, and that is the mechanical forces between neighbouring turns of the winding to which these currents give rise. For example, if a current of 10,000 amperes flows in the solenoid winding and a field strength in the central part of the solenoid core is developed of, say, 500,000 gauss, the mechanical force which will be exerted on the wire of the inner layer per inch length will be

$$\frac{500,000 \times 2.54 \times 10,000}{10} = 12.7 \times 10^8 \text{ dynes,}$$

that is,

1.28 tons weight per inch length of wire.

It is clear, therefore, that the neighbouring turns of the solenoid will be subject to enormous mechanical forces. The tendency of these mechanical forces is to draw the turns of the solenoid towards the central part of the bobbin. The result of this is that the wire becomes stretched and eventually will break unless precautions are taken. The danger of the winding being ruptured when the current is flowing is that a violent spark is produced under the oil and in

consequence a disastrous explosion may occur. In order to avoid this danger, the coil is provided with a steel cradle which is lined with hard wood and is then fitted close on to the winding.

When the apparatus is working under its normal conditions, the time which elapses between two successive discharges of the condenser is about 12 minutes. By keeping the automatic oscillating switch in operation for 8 hours per day, it is thus possible to obtain about 240 discharges per week, or about 1000 discharges per month.

The measurement of the magnitudes of the very heavy currents which are generated when the condensers are discharged through the solenoid winding is made by means of the Duddell high-frequency oscillograph and "falling plate" camera.

In order to ensure that the photographic plate shall pass across the exposure slit at precisely the moment at which the condenser discharge is taking place, an electro-magnetic release device for the plate is employed. The electro-magnet circuit is closed by means of a contact fixed to the arm of the switch which closes the discharge circuit of the condensers. By suitably adjusting the position of the contact, it is possible so to arrange matters that the condenser discharge takes place just as the plate is passing across the exposure slit.

The setting of the contact-maker for the plate release electro-magnet proved to be extremely sensitive, and very slight changes in the friction of the plate in the guides was sufficient to completely upset it so that the condenser discharge was completed either before or after the plate had passed across the exposure slit. It was eventually found to be necessary to provide means for eliminating the disturbing effect of slight errors or alterations in the setting of the contact-maker. For this purpose, a special plate frame was made which would carry three plates, thus forming, in effect, one continuous plate about 18 in. long. In this way, it has been found possible to ensure that the condenser discharge takes place whilst at least some portion of this composite plate was crossing the exposure slit.

The frequency of the oscillatory current produced by the condenser discharge is measured by connecting one strip of the oscillograph to

measured by the Kelvin electrostatic voltmeter O . When the switch lever E moves over to the right-hand side, contact is first made in the two mercury cups, J , the result of this being to connect the two condenser sets B in series. The actual closing of the condenser discharge circuit is effected by contact in the large mercury cup H .

A special precaution was also taken in regard to the P.D. oscillograph connections for measuring the P.D. wave across the coil. For this purpose non-inductive double strips V (Fig. 75) were connected directly to the solenoid terminals, the length of each double strip being about 2 in. Tappings were taken from the top of these double strips, one of these tappings being shown in Fig. 75. In this way any mutual induction effects in the P.D. leads due to the heavy currents in the circuit could be eliminated. It was found, however, that mutual induction effects in the P.D. circuit of the oscillograph circuit were insignificantly small even without this special precaution.

The slide frame for the photographic plates is shown at N and the electro-magnet for the plate release at M . The circuit of this electro-magnet is closed as the switch lever E moves over to the right-hand side.

The a.c. wave of 50 frequency for measuring the frequency of the oscillatory discharge currents in the solenoid A , and also for calibrating the oscillograph, is obtained from the supply mains shown at Y .

The calibration of the oscillograph is performed by connecting the two strips in series with each other through a known resistance and supplying the circuit from the a.c. source Y , the P.D. being accurately measured.

For each condition of condenser discharge, two sets of oscillograms were usually taken, viz.,

- (i) One set giving the waves of the P.D. and the current in the solenoid.
- (ii) One set giving the wave of the condenser discharge current and a sinusoidal wave of known frequency.

The second of these two sets of oscillograms provides the scale for measuring the frequency of the condenser discharge current.

50. The Current Produced when the Condenser is Discharged

The theory of the method of generating very large currents by the discharge of static condensers through a solenoid of low resistance may be briefly stated as follows :

Let C farads be the capacity of the static condensers,

„ L henrys be the inductance of the circuit, that is to say, the inductance of the solenoid and the connecting leads,

„ R ohms be the resistance of the circuit.

If the static condensers are charged up to a potential of V volts and then discharged through the solenoid, the discharge current will be oscillatory if the resistance R is small. It is essential for the success of the method that the resistance shall be as small as is practicable without seriously affecting the other essential conditions of the circuit.

When the static condensers are discharged through the solenoid, the magnitude of the current at any moment t will be given by the expression

$$i = \frac{V}{L\sqrt{\frac{1}{CL} - \frac{1}{4} \frac{R^2}{L^2}}} e^{-\frac{1}{2} \frac{R}{L} t} \sin \sqrt{\frac{1}{CL} - \frac{1}{4} \frac{R^2}{L^2}} t \text{ amperes}$$

where $e = 2.713 \dots$ and is the base of natural logarithms.

The frequency of the oscillatory discharge current will be

$$f = \frac{\sqrt{\frac{1}{CL} - \frac{1}{4} \frac{R^2}{L^2}}}{2\pi}$$

If the factor $\frac{1}{4} \frac{R^2}{L^2}$ is negligibly small as compared with the quantity $\frac{1}{CL}$, the frequency will be

$$f = \frac{1}{2\pi \sqrt{CL}}$$

The first peak value of the current will be obtained by putting

$$t = \frac{1}{4} \left[\frac{2\pi}{\sqrt{\frac{1}{CL} - \frac{1}{4} \frac{R^2}{L^2}}} \right]$$

in the expression for i . If the quantity $\frac{1}{4} \frac{R^2}{L^2}$ is again neglected as compared with the quantity $\frac{1}{CL}$, the first peak value I_1 of the oscillatory discharge current will be given by

$$I_1 = V \sqrt{\frac{C}{L}} e^{-\frac{\pi R}{4} \sqrt{\frac{C}{L}}} \text{ amperes.}$$

It will be noticed that the expression for the first peak value of the condenser discharge current contains the decrement factor

$$e^{-\frac{\pi}{4} \sqrt{\frac{C}{L}} R}$$

The magnitude of this factor increases as the resistance R decreases, if the other quantities remain the same. If, however, the magnitude of R is decreased by decreasing the number of turns on the solenoid, the value of the inductance L is also decreased. This increases the magnitude of the decrement factor and the question as to whether the resulting magnitude of the first peak value I_1 of the discharge current is decreased or increased as L decreases depends upon the actual numerical values of the circuit constants.

EXAMPLE.—In Fig. 76 the oscillograms refer to the case in which the condensers were charged to a P.D. of 2126 volts and then discharged through a solenoid wound on an ebonite core. From both oscillograms the first peak of the current wave is found to be 4520 amperes. The second peak of the current wave has a magnitude of 2750 amperes.

The instantaneous value of the current at any time t subsequent to the commencement of the discharge is

$$i = \frac{V}{L\omega} e^{-1(R/L)t} \sin \omega t$$

where

$$\omega = 2\pi f = \sqrt{\left[\frac{1}{LC} - \frac{R^2}{4L^2}\right]}$$

or

$$f = \frac{1}{2\pi} \sqrt{\left[\frac{1}{LC} - \frac{R^2}{4L^2}\right]}$$

The magnitude I_1 of the first peak of the current wave is obtained by putting $t = 1/(4f)$ so that the magnitude of the first peak of the current wave is

$$I_1 = \frac{V}{L\omega} e^{-R/(8Lf)}$$

Similarly, the magnitude I_2 of the second peak is obtained by putting $t = 3/(4f)$, so that

$$I_2 = \frac{V}{L\omega} e^{-3R/(8Lf)}$$

and consequently

$$\frac{I_2}{I_1} = e^{-R/(4Lf)}$$

Now it is found by measurement of the oscillogram (b) in Fig. 76 that the value of the frequency is

$$f = 1340 \text{ cycles per second,}$$

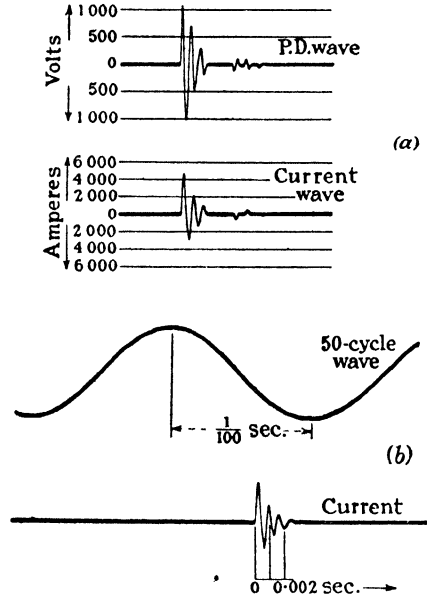

FIG. 76.

also, from the oscillograms in Fig. 76,

$$\frac{I_2}{I_1} = 0.61,$$

from which it follows that

$$R = 0.114 \text{ ohm,}$$

since the total inductance of the circuit was

$$L = \frac{43.4}{10^6} \text{ henry.}$$

Taking, then, the effective resistance of the discharge circuit

to be 0.114 ohm, the value of the first peak of the current wave and also the frequency may be calculated. Thus in this case,

$$V = 2126 \text{ volts; } L = 43.4 \times 10^{-6} \text{ henry; } C = 339 \mu F;$$

$$\left(\frac{1}{2} \frac{R}{L}\right)^2 = (1310)^2 = 1.73 \times 10^6$$

$$\omega = \sqrt{\left[\frac{1}{LC} - \left(\frac{1}{2} \frac{R}{L}\right)^2\right]} = 8150$$

that is, $f = 1300$ cycles per second.

Substituting in the expression for the first current peak

$$I_1 = \frac{V}{L\omega} e^{-R/(8Lf)}$$

gives

$$I_1 = 4682 \text{ amperes.}$$

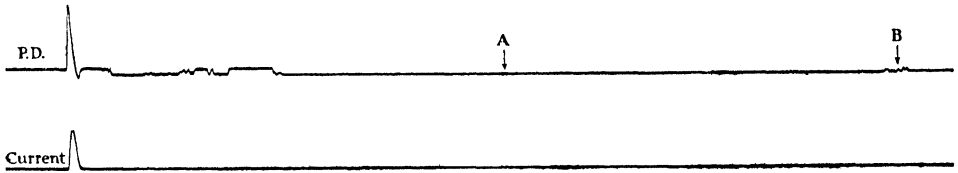

FIG. 77.

The calculated value of the first peak of the current wave is thus about 1.03 times the value measured from the oscillograms (a) and (b) in Fig. 76, whilst the calculated value of the frequency is about 0.97 of the value measured on the oscillogram (b), Fig. 76.

An interesting oscillogram is shown in Fig. 77, which refers to a solenoid wound on a steel bobbin. The condensers were connected all in parallel, charged up to 2126 volts and then connected in two sets in series for discharging. The coil burst when the discharge took place, and the oscillogram of Fig 77 shows the sequence of events after the discharge circuit was closed. The current wave comprises a single peak and then falls to zero. The peak value of the current wave as measured from the oscillogram is found to be 2230 amperes.

The P.D. wave shown in the oscillogram exhibits some remarkable features. For example, the P.D. becomes zero at the same time that

the current falls to zero, and the P.D. remains zero for about 0.002 sec. The P.D. oscillogram then shows high-frequency ripples of small amplitude, afterwards becoming definitely negative and remaining negative for about 0.005 sec. The P.D. then becomes oscillatory and reaches the zero value, remaining zero for about 0.001 sec. After further fluctuations the P.D. again becomes definitely negative and remains negative but develops occasional ripples of high frequency and small amplitude (see *A, B*, Fig. 77).

The curious activity of the P.D. after the current has ceased to flow appears to be definitely due to the iron of the bobbin. This is evident from the fact that when a solenoid of similar winding data but wound on an ebonite bobbin burst, no such high-frequency ripples were developed in the P.D.

It would further appear that the atomic disturbance of the material of the bobbin took some considerable time to settle down to a state of quiescence, that is, in so far as its external effects are concerned.

51. Experiments with Moderately Intense Magnetic Fields

As a preliminary to the main experimental undertaking outlined in the foregoing pages of this chapter, some experiments were made with moderately intense fields as follows: The tests were made on a specimen consisting of a nest of four cylindrical tubes of stalloy, which, when assembled together, formed a tubular specimen cylindrically laminated. A search coil of 314 turns and an exciting coil of 9 turns were wound on the tube, the magnetic circuit being a closed path in the stalloy. The dimensions were such that, when a current of 1 ampere was passed through the exciting coil, the intensity of the magnetic force along the mean magnetic path was 2.7 gauss.

The specimen was subjected to a magnetic field by passing an alternating current of 50 frequency through the exciting coil, the peak value of the current being 3.1 amperes. This current was maintained for a few seconds and then gradually reduced to zero, thus completely demagnetising the specimen, after an alternating field

of about 12,000 lines per sq. cm. had been developed in the mean magnetic path of the material of the specimen for the duration of a few seconds.

The $B : H$ curve was then determined by the method of reversals, starting with very low values of the exciting current. The portion

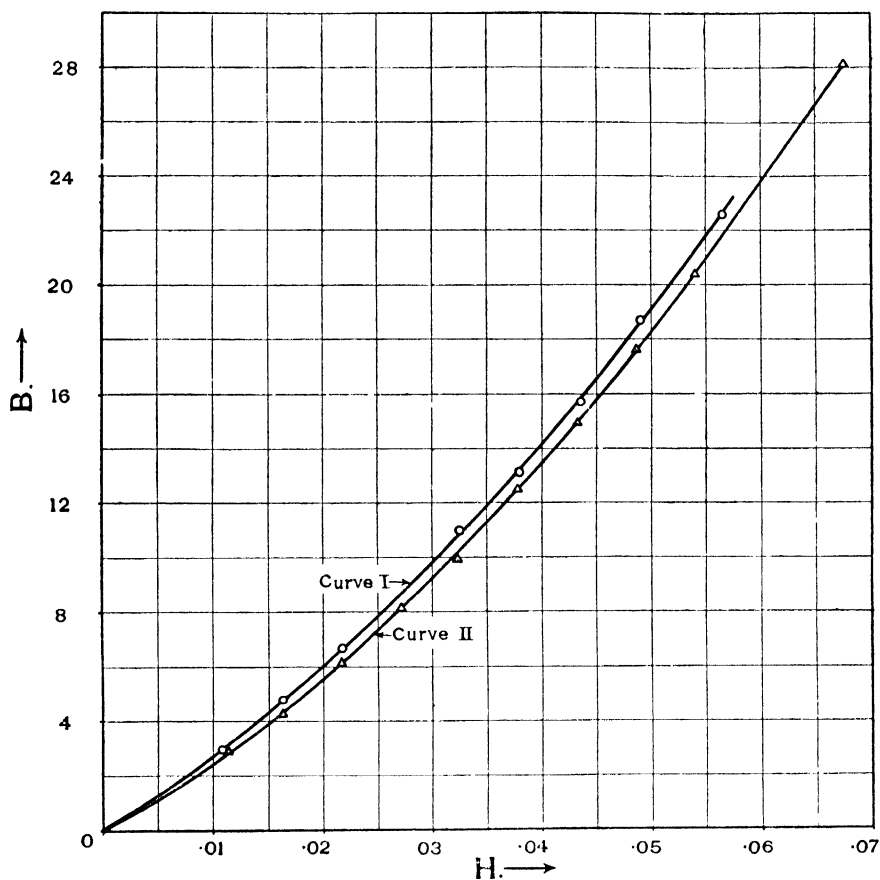

FIG. 78.

of this curve near the origin is shown by Curve I in Fig. 78. The specimen was then again completely demagnetised and after it had been allowed to rest for 16 hours the $B : H$ curve was again determined and is shown as Curve II in Fig. 78.

It will be seen that Curve II is distinctly lower than Curve I,

and in order to facilitate the comparison, the numerical data are given in the following table :

Magnetising Force. H	Magnetic Curve I. B_I	Induction Curve II. B_{II}	Ratio. $B_I : B_{II}$
0.015	4.4	3.9	1.13
0.025	7.9	7.2	1.10
0.035	11.9	11.1	1.07
0.045	16.6	15.6	1.06
0.055	21.7	20.7	1.05

It is to be observed that the values of the magnetic induction given by Curve I are as much as 13% higher than those given by Curve II.

By again subjecting the specimen to a magnetising field of the same intensity as before and then demagnetising it, the Curve I could be re-obtained.

By maintaining uninterruptedly the alternating current in the exciting coil for several weeks, it was found after demagnetisation that the $B : H$ curve was still higher than Curve I. After the specimen had remained at rest for one week, however, the $B : H$ curve fell in a similar manner to Curve II.

It thus appears that, by subjecting the magnetic substance to fields of even moderate intensity, it is possible to produce a definite temporary change in its magnetisation curve, and this fact appears to indicate that a corresponding temporary change in the electronic orbits takes place.

PART II

MAGNETIC TESTING

CHAPTER IX

THE BALLISTIC GALVANOMETER : THE FLUXMETER

52. The Ballistic Galvanometer Formulæ

A ballistic galvanometer is used to measure the *quantity of electricity* which is passed through the galvanometer, a requisite condition of the measurement being that the discharge is complete before an appreciable deflection has been produced.

Usually, a ballistic galvanometer has a fixed magnet system and a movable coil. Sometimes, however, the magnet system is movable and the coil is fixed, as, for example, in the Broca galvanometer.

The conditions which a ballistic galvanometer should fulfil are (i) the moving system should have a large moment of inertia, so that the discharge through the galvanometer shall be complete before an appreciable deflection of the moving system has taken place; (ii) the damping of the moving system should be small, so that, other conditions being the same, the "throw," or first full deflection, shall be as large as possible.

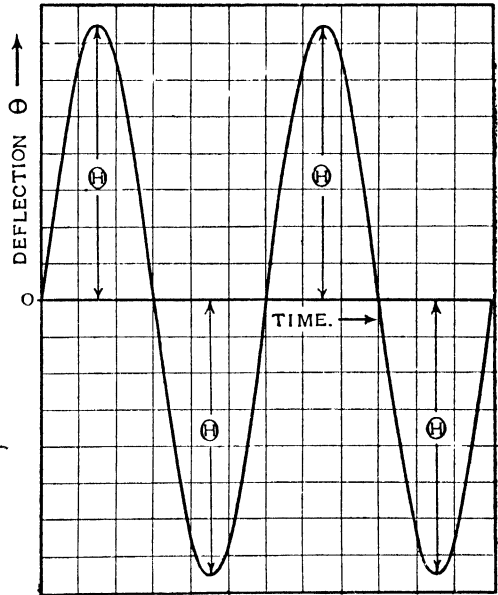

FIG. 79.

- Let J be the moment of inertia of the moving system,
- „ θ „ deflection at any time t ,
- „ $k\frac{d\theta}{dt}$ „ damping couple when the velocity is $\frac{d\theta}{dt}$
- „ $c\theta$ „ controlling couple.

If there were no damping whatever, the galvanometer would continue swinging indefinitely, the deflection on each side of the zero being the same amount as shown in Fig. 79.

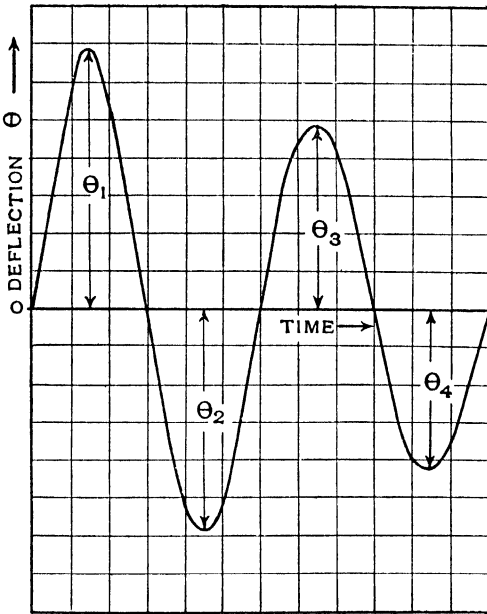

FIG. 80.

Actually, however, the damping causes the deflection to be less than this ideal undamped deflection, and the amount of the deflection on each side of the zero decreases in magnitude as shown in Fig. 80, where

- θ_1 is the 1st deflection,
- θ_2 „ 2nd „
- θ_3 „ 3rd „
-
- θ_n „ nth „

Now it can be shown that the expression

$$\frac{1}{n - 1} \log_e \frac{\theta_1}{\theta_n}$$

is a constant for all values of n . This constant is called the *logarithmic decrement* and will be denoted in what follows by the Greek letter λ (lambda).

If, for example, the 1st deflection and the 11th deflection be noted, then

$$\lambda = \frac{1}{10} \log_e \frac{\theta_1}{\theta_{11}}$$

or reducing the logarithm to the base 10,

$$\lambda = 0.23 \log_{10} \frac{\theta_1}{\theta_{11}}$$

Then θ the ideal undamped deflection will be given by

$$\theta = \theta_1 \left(1 + \frac{\lambda}{2} \right)$$

The quantity of electricity which has been discharged through the galvanometer will be

$$\begin{aligned} Q &= \left(\frac{c}{x} \frac{T}{2\pi} \right) \theta \\ &= b \theta \text{ coulombs.} \end{aligned}$$

In this expression x and b are constants of the galvanometer. The factor b is the “ballistic constant” and must be found from a calibration test of the galvanometer.

The symbol T denotes the time in seconds of *one complete oscillation* of the galvanometer coil, that is, the time between a full deflection on one side of the zero and the next full deflection *on the same side of the zero*.

For example, in Fig. 80,

T is the time in seconds between the deflections θ_1 and θ_3 , or between θ_3 and θ_5 , and so on.

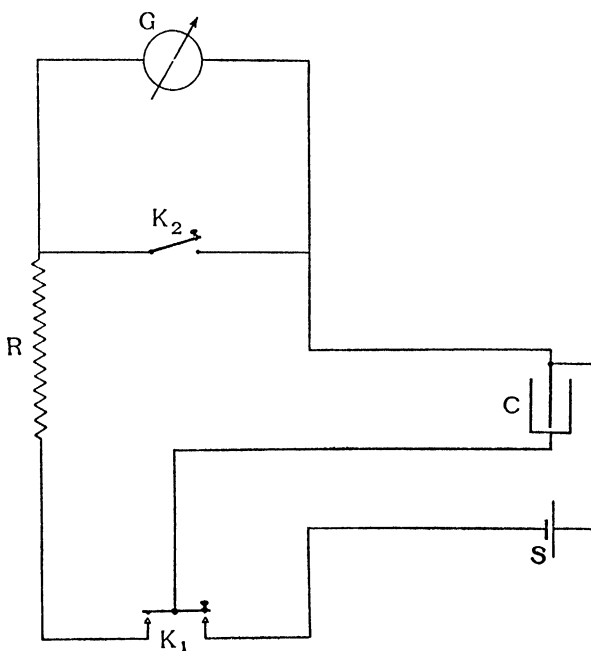

FIG. 81.

53. Determination of the Ballistic Constant

Three methods are available for measuring the ballistic constant of a galvanometer, viz., by means of—

- (i) A standard cell and a standard capacity,

- (ii) A standard cell and a standard resistance,
- (iii) A standard mutual induction and a known current.

Method I. Using a Standard Cell and a Standard Capacity

Make the system of connections shown in Fig. 81, where

- $\cdot S$ denotes the standard cell,
- B „ „ standard condenser,
- K_1 „ a Morse key,
- K_2 „ a damping key,
- R „ a resistance of a few thousand ohms.

Charge the condenser by pressing the key K_1 and then discharge it through the galvanometer by releasing the key K_1 .

Note the first full deflection θ_1 of the galvanometer and, say, the 5th deflection, that is, θ_5 .

Then the logarithmic decrement is

$$\lambda = \frac{2.3}{4} \log_{10} \frac{\theta_1}{\theta_5}$$

The first undamped swing will then be given by

$$\theta = \theta_1 \left(1 + \frac{\lambda}{2} \right)$$

The ballistic constant b will be

$$b = \frac{V \times C}{\theta}$$

where V is the voltage of the standard cell and C farads the capacity of the standard condenser. If a Weston cell is used as the standard, $V = 1.0183$ volts.

EXAMPLE.—In one test it was found that when a standard condenser of 0.3 mfd. capacity was charged to 1.0183 volts by means of a Weston standard cell and then discharged through the ballistic galvanometer, the following values of the deflections were noted, viz. :

$$\theta_1 = 62.0 \text{ mms.}$$

$$\theta_5 = 48.7 \text{ „}$$

The logarithmic decrement was therefore

$$\lambda = \frac{2.3}{4} \log_{10} \frac{62.0}{48.7} = 0.060.$$

The magnitude of the undamped swing of the galvanometer was therefore

$$\theta = \theta_1 \left(1 + \frac{\lambda}{2}\right) = 62.0 \times 1.03 = 64.0.$$

Hence the ballistic constant of the galvanometer was

$$b = \frac{1.0183 \times 0.3}{64.0 \times 10^6} = 4.78 \times 10^{-9} \text{ coulombs per mm. of scale deflection.}$$

It is to be noted that the resistance R has no appreciable effect on the galvanometer deflection—unless the magnitude of R is of the order of infinity.

Method II. Using a Standard Cell and a Known Value of the Current

Connect up the galvanometer as shown in Fig. 82, where

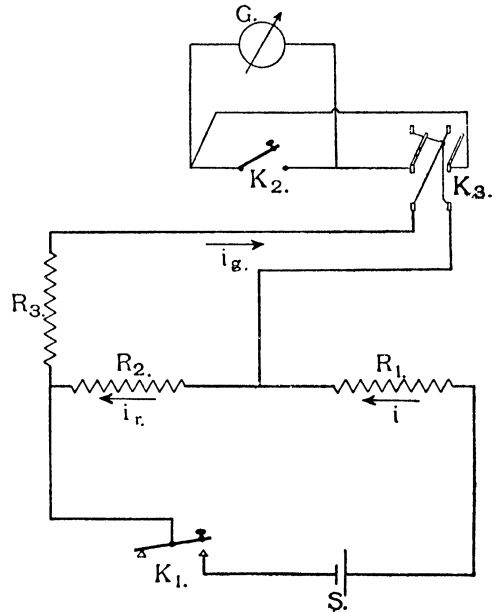

FIG. 82.

- S denotes the standard cell,
- R_1, R_2, R_3 „ „ galvanometer resistance,
- K_1 „ a Morse key,
- K_2 „ a press key,
- K_3 „ a double pole reversing switch.

The resistance R_1 may be of the order of 1 megohm, and the resistances R_2 and R_3 may each be of the order of a few thousand ohms.

For this method of measuring the ballistic constant, it is necessary to know T , the time of a complete oscillation of the galvanometer spot. This quantity may be found by setting the galvanometer

spot swinging by momentarily pressing the key K_1 . It is advisable to measure, by means of a stop-watch, the time taken for, say, 5 or 10 complete swings and thus obtain with reasonable accuracy, the mean time for one complete oscillation.

The magnitude of the resistances R_2 and R_3 should be adjusted so that on keeping the key K_1 pressed, the steady deflection of the galvanometer is a reasonable amount.

By means of the reversing key K_3 find the galvanometer steady deflection on the other side of the scale zero, and for the same values of the resistances R_1 , R_2 and R_3 .

The mean of the two readings may be taken as the true value of the steady deflection due to that value of the galvanometer current.

A series of readings should be taken in this way, and the values of the galvanometer deflections and the corresponding values of the galvanometer currents plotted. This should give a straight line relationship. From the straight line so obtained, the mean value of the galvanometer deflection per microampere is found.

Let V volts be the e.m.f. of the standard cell S .

The galvanometer current i_g will be given by the relationship

$$i = i_g + i_r \text{ (see Fig. 80),}$$

where

$$i = \frac{V}{R_1 + \frac{R_2 R_3}{R_2 + R_3}} \text{ amperes}$$

and

$$\frac{i_g}{i_r} = \frac{R_2}{R_3}$$

(*Note.*—The resistance R_3 is, of course, inclusive of the resistance of the galvanometer itself.)

The galvanometer ballistic constant will then be

$$b = \frac{c}{x} \frac{T}{2\pi}$$

where

$$\frac{c}{x} = \frac{i_g}{\theta}$$

θ being the mean value of the steady deflection when a current of i_g amperes flows through the galvanometer.

NUMERICAL EXAMPLE.—In the case of the same ballistic galvanometer as was used for the numerical examples given in Method I and also in Method III below, the following data were obtained :

- Time of one complete oscillation . . . $T = 18$ seconds,
- Galvanometer current $i_g = 0.0926 \times 10^{-6}$ amperes,
- Mean value of the steady deflection . $\theta = 54.9$ mm.

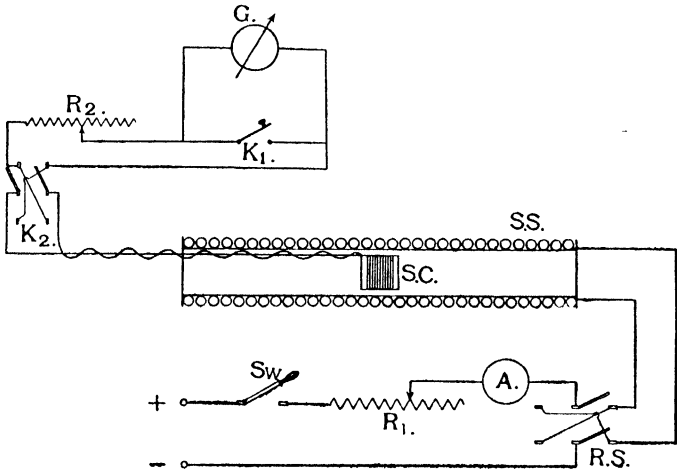

FIG. 83.

Hence,

$$\frac{c}{x} = \frac{0.0926}{10^6 \times 54.9} = \frac{1.685}{10^9}$$

$$\frac{T}{2\pi} = \frac{18}{2\pi} = 2.86$$

and the ballistic constant is therefore

$$b = \frac{1.685 \times 2.86}{10^9}$$

$$= 4.82 \times 10^{-9} \text{ coulombs per mm. of scale deflection.}$$

Method III. Using a Standard Solenoid

The standard solenoid is one which is wound on a bobbin of non-magnetic material and which has a length which is great compared with the diameter.

Supported within the solenoid at the centre of the core is a search coil of which the dimensions are accurately known.

The search coil is connected to the galvanometer and the solenoid winding is connected to a battery of accumulators through a reversing switch, as shown in Fig. 83.

The strength of the magnetic field at the central part within the core of a solenoid is given by the expression :

$$H = k \frac{4\pi}{10} \frac{w_1 I}{l} \text{ gauss}$$

in which

I amperes is the current in the solenoid winding,

l cms. is the length of the solenoid,

w_1 turns is the total number of turns in the solenoid winding,

k is a correction coefficient.

The magnitude of the correction coefficient k is given by the following expression, viz. :

$$k = \frac{l}{4d} \log_e \frac{(a+d) + \sqrt{(a+d)^2 + \left(\frac{l}{2}\right)^2}}{(a-d) + \sqrt{(a-d)^2 + \left(\frac{l}{2}\right)^2}}$$

where

a cms. is the mean radius of the solenoid winding,

$2d$ cms. is the radial depth of the solenoid winding,

l cms. is the length of the solenoid winding,

as shown in Fig. 84.

If the radial depth ($2d$) of the winding is small, that is, if the solenoid is wound with, say, one or two layers of thin wire, the expression for the intensity of the magnetic field at the central part within the core of the solenoid may be written

$$H = \frac{2\pi}{10} \frac{w_1}{\sqrt{a^2 + \left(\frac{l}{2}\right)^2}} I \text{ gauss.}$$

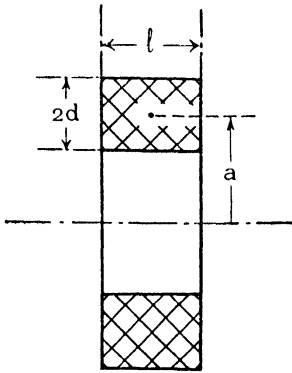

FIG. 84.

When the quantity a is small compared with the quantity l , that is, when the solenoid is of considerable length as compared with its diameter, the field strength at the central part within the core of the solenoid is uniform and each of the two foregoing expressions for the intensity of the magnetic field may be written in the simple form

$$H = \frac{4\pi}{10} \frac{w_1}{l} I \text{ gauss,}$$

or, expressed in words, *the intensity of the magnetic field at the central part within the core of a solenoid is equal to 1.257 times the ampere-turns per cm. length of the solenoid winding.* See also Chapter XI, § 63.

If the search coil has w_2 turns and if the effective cross-sectional area of the search coil is A_2 sq. cms., the flux-linkages of the search coil when in position at the central part of the solenoid core will be

$$HA_2w_2.$$

When the solenoid current is *reversed*, the total change of flux-linkages of the search coil will be

$$2HA_2w_2.$$

If R ohms be the total resistance of the galvanometer circuit including the resistance of the search coil, the quantity of electricity which will be discharged through the galvanometer when the current in the solenoid winding is reversed is :

$$\frac{2HA_2w_2}{R10^8} \text{ coulombs.}$$

Hence, if θ be the *undamped* galvanometer throw when the solenoid current is reversed, then

$$\begin{aligned} \frac{2HA_2w_2}{R10^8} &= \frac{c}{x} \frac{T}{2\pi} \theta \\ &= b\theta \end{aligned}$$

where b is the ballistic constant.

Therefore

$$b = \frac{2HA_2w_2}{R\theta 10^8}$$

where

$$H = \frac{4\pi}{10} \frac{w_1 I}{l}$$

NUMERICAL EXAMPLE.—The standard solenoid in Sheffield University is wound on a “Bakelite” tube and has a length of winding of 166 cms. The winding of the solenoid consists of 1638 turns of copper wire.

The search coil has 361 turns and the mean area of the coil is 12.75 sq. cms. Hence

$$A_2w_2 = 4600.$$

When a current of 3.53 amperes was reversed in the solenoid winding, the undamped galvanometer throw was 84.6 mms., the total resistance of the galvanometer circuit being 10,000 ohms. The galvanometer used was the same as that to which the numerical examples in Methods I and II refer.

Hence

$$\begin{aligned} H &= \frac{4\pi}{10} \frac{w_1 I}{l} \\ &= \frac{4\pi}{10} \frac{1638 \times 3.53}{166} \\ &= 43.8 \text{ gauss.} \end{aligned}$$

Therefore

$$\frac{c}{x} \frac{T}{2\pi} \theta = \frac{2 \times 43.8 \times 4600}{10,000 \times 10^8}$$

or

$$\frac{c}{x} \frac{T}{2\pi} = \frac{2 \times 43.8 \times 4600}{10,000 \times 10^8 \times 84.6}$$

That is, the ballistic constant is

$$\begin{aligned} b &= \frac{c}{x} \frac{T}{2\pi} \\ &= \frac{4.76}{10^9} \text{ coulombs per mm. of the scale deflection.} \end{aligned}$$

Instead of determining the mean value of the cross-sectional area A_2 of the search coil by measuring the mean diameter, the product A_2w_2 may be found more accurately by measuring the mutual induction of the search coil with respect to the solenoid.

Thus if M henrys is the mutual induction so found, that is

$$M = \frac{\text{flux-linkages of search coil}}{10^8}$$

when 1 ampere flows in the solenoid.

Therefore

$$\frac{4\pi}{10} \frac{w_1}{l} (A_2w_2) = M \times 10^8$$

or,

$$A_2w_2 = \frac{M \times 10^8}{\frac{4\pi}{10} \frac{w_1}{l}}$$

The mutual inductance M may be measured by any of the standard methods such as that of Carey Foster or by means of a standard mutual inductance.

Method IV. Calibration by Means of the Duddell Magnetic Standard

This method of calibration is a convenient one when the range of flux-linkages of the magnetic standard is of the same order as that of the search coil on the specimen under test.

The principal purpose for which the Duddell magnetic standard is intended to be used is the calibration of a ballistic galvanometer for the same conditions as those under which the galvanometer is actually used for the magnetic test. It is thus possible to obtain the calibration curve for the galvanometer directly without having to determine the ballistic constant.

The instrument consists of two fixed coils, C, C , Fig. 85, through which a known value of direct current is passed, and two movable coils, D, D , Fig. 85, which latter are connected in series with the

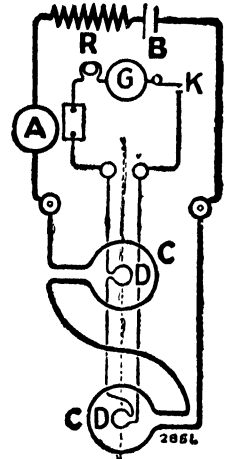

FIG. 85.

galvanometer which is to be calibrated. By releasing a spring, the moving coils are suddenly turned through an angle of 180° . They will thus cut the lines of magnetic force which are generated by the current in the fixed coils and a corresponding deflection of the galvanometer will be produced. The general arrangement of the connections and of the coils in the instrument are shown in Fig. 85.

The magnetic standard is itself calibrated by some more fundamental standard such as the long solenoid, as described in Method III, and the calibration constant is supplied with the instrument. Thus, in a particular instrument, when a current of 1 ampere is flowing in the fixed coils the change in flux-linkages of the movable coils when the spring is released was found to be 100,200.

In using the magnetic standard for calibrating a ballistic galvanometer it is thus necessary to be able to measure accurately the current in the fixed coils, *e.g.*, a precision ammeter should be used.

The resistance of the fixed coils is only 0.075 ohm, so that a single 2-volt accumulator is sufficient to send the necessary current through the fixed coils.

The coils *DD* of the magnetic standard are kept permanently in circuit with the search coil of the specimen; that is to say, not only when the calibration of the galvanometer is being made, but also when the magnetic test of the specimen is being carried out.

By noting the deflection of the ballistic galvanometer for a series of values of the current in the fixed coils of the magnetic standard, it is possible to calibrate the galvanometer for the whole range of the scale.

54. The Grassot Fluxmeter

The principle of action of this instrument is that of an uncontrolled moving coil galvanometer, the moving coil being suspended by a single cocoon fibre which is, as nearly as possible, without any torsion. In this way, the control on the moving coil is made practically negligibly small.

A sketch of the moving coil system of this instrument is shown in Fig. 86. The ends of the moving coil B are brought out to terminals as shown. The single cocoon fibre which suspends the coil is fixed at the upper end to a flat spiral spring A so that any risk of rupture due to mechanical shock is minimised. The coil is connected through the two spirals $C C$ of thin silver strip so that no appreciable control is exerted on the coil due to these connections.

The coil is suspended in a magnetic field provided by the permanent magnet system NS .

The most important application of this instrument is the direct measurement of magnetic fluxes. For this purpose, a search coil is provided which is connected to the terminals of the moving coil of the fluxmeter. If the search coil is made to thread a magnetic flux, or more generally, if the magnetic flux which threads the search coil is altered, it may be shown that the corresponding deflection of the fluxmeter needle is directly proportional to the change of flux linkages of the search coil.

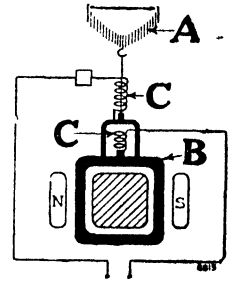

FIG. 86.

For instance, if in Fig. 87 the search coil is moved from the position A to the position B , the resulting deflection of the fluxmeter needle due to this movement will be proportional to the change in flux-linkages of the search coil in moving from the position A to the position B . That is to say, if there are w turns in the search coil and if the flux which threads the search coil changes by an amount Φ when the search coil is moved from the position A to the position B , the corresponding deflection of the fluxmeter needles will be proportional to the product

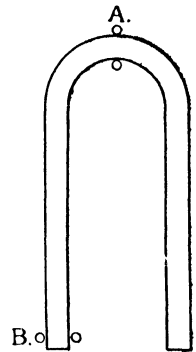

FIG. 87.

$$w\Phi.$$

Theory of the Fluxmeter.

Let ϕ_x be the magnetic flux which threads the search coil at any instant,

- Let w be the number of turns in the search coil,
 „ i amperes be the current at any instant in the series connection of search coil and fluxmeter coil,
 „ $\frac{d\theta}{dt}$ radians per second be the angular velocity of the search coil at any instant,
 „ e_f volts be the back e.m.f. induced in the moving coil of the fluxmeter at any instant and due to its movement in the magnetic field of the fluxmeter,
 „ e_s volts be the e.m.f. induced in the search coil at any instant and due to the change of flux-linkages of this coil,
 „ r ohms be the total resistance of the series circuit of search coil and fluxmeter coil.

The e.m.f. e_s induced in the search coil at any instant will be proportional to the *rate of change* of the flux-linkages of the search coil. That is,

$$e_s = \frac{w}{10^8} \frac{d\phi_x}{dt} \text{ volts.}$$

The e.m.f. e_f induced in the moving coil of the fluxmeter will be proportional to the angular velocity of this coil in the magnetic field provided by the permanent magnet system of the fluxmeter. That is,

$$e_f = k \frac{d\theta}{dt} \text{ volts,}$$

where k is a constant of the instrument.

If the air damping and friction of the moving coil system of the fluxmeter are small, it follows that the electrical power developed in the search coil is equal to the electrical power supplied to the whole system of search coil and fluxmeter moving coil. That is,

$$e_s i = e_f i + r i^2.$$

If i is small, which will be the case if the fluxmeter coil is not too heavy and if the air friction and other friction losses are small,

and if the permanent magnet system of the fluxmeter is sufficiently powerful, then the resistance loss ri^2 may be taken as negligibly small.

Hence

$$e_s = e_f$$

or

$$\frac{w}{10^8} \frac{d\phi_x}{dt} = k \frac{d\theta}{dt}$$

Integration of this equation gives

$$\frac{w}{10^8} (\phi_1 - \phi_2) = k(\theta_2 - \theta_1) = k\theta$$

or

$$\Phi = \phi_1 - \phi_2 = \frac{k10^8}{w} \theta$$

where ϕ_1 is the flux threading the search coil at its first position and ϕ_2 is the flux threading the search coil at its final position. The symbol θ denotes the deflection of the fluxmeter needle due to the movement of the search coil in the magnetic field which is being explored. That is to say, θ_1 is the reading of the fluxmeter needle at the beginning and θ_2 the reading of the needle at the end of the movement of the search coil.

If a series of search coils is available, each having a different number of turns, it is possible to measure a great range of magnetic fluxes.

For many purposes it is desirable to be able to extend the effective range of the fluxmeter scale to measure very large fluxes. This can be done by the use of a shunt across the terminals of the fluxmeter coil, the resistance of the shunt being small as compared with the resistance of the fluxmeter coil.

In Fig. 88 is shown a diagrammatical sketch of the arrangement.

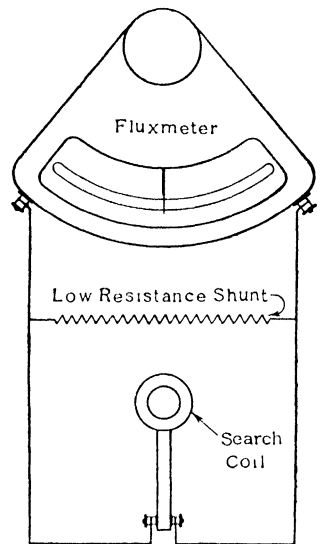

FIG. 88.

It may be proved that, in this case, the change of flux threading the search coil is

$$\Phi = k \left(\frac{r_s + x}{wx} \right) 10^8 \theta$$

where r_s ohms is the resistance of the search coil and x ohms is the resistance of the shunt; the other symbols have the same significance as previously.

EXAMPLE.—The constant of the fluxmeter available for the test was such that one scale division represented a change of flux-linkages of the search coil of 14,000. That is,

$$k = \frac{14,000}{10^8}$$

The search coil had 100 turns, the mean area of the winding being 5.42 sq. cms.

In the test considered, a bar magnet was passed through the search coil and arranged so that the coil was at the centre of the bar. When the coil was drawn off the end of the magnet the consequent deflection of the fluxmeter needle was 2 divisions, the fluxmeter being used without a shunt.

The total flux Φ at the middle of the bar magnet embraced by the search coil was therefore given by the expression

$$\Phi w = 2 \times 14,000 = 28,000.$$

Since the number of turns w in the search coil was 100, it follows that the total flux threaded by the search coil when placed at the middle of the magnet was

$$\Phi = 280 \text{ lines.}$$

If the flux threading the search coil had been uniformly distributed, the induction density would have been

$$\begin{aligned} B &= \frac{\Phi}{\text{mean area of the search coil}} \\ &= \frac{280}{5.42} \\ &= 52 \text{ lines per sq. cm.} \end{aligned}$$

CHAPTER X

DETERMINATION OF THE MAGNETISATION CURVE AND THE HYSTERESIS LOOP, (I) BY THE METHOD OF REVERSALS; (II) BY THE "STEP-BY-STEP" METHOD

THESE methods are suitable for testing ring specimens up to values of the magnetising force H of about 250 gauss.

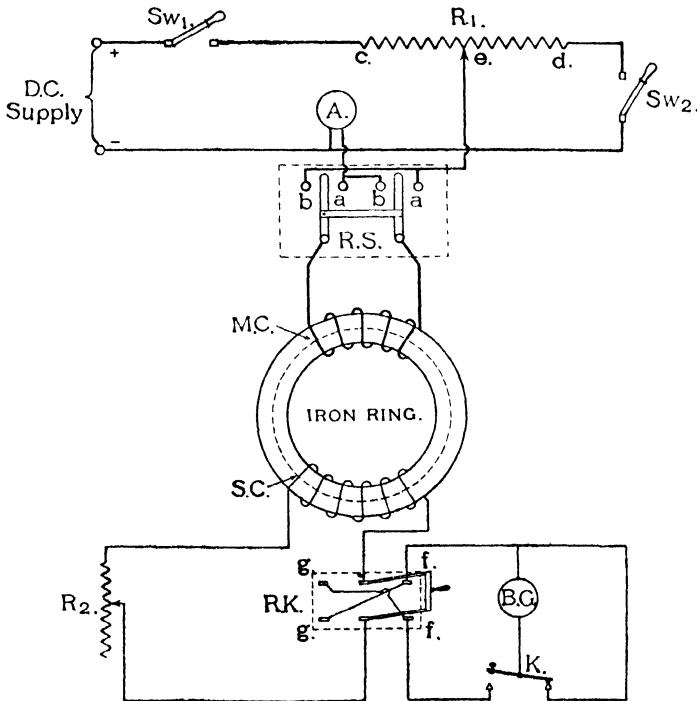

FIG. 89.

55. The Determination of the Magnetisation Curve by the Method of Reversals

The diagram of connections for this test is shown in Fig. 89. The specimen is in the form of a machined ring, the dimensions of which are accurately known. This ring is provided with a magnetising coil evenly wound over the whole surface, the coil being shown diagrammatically by MC in Fig. 89.

The mean magnetic circuit of the ring specimen is shown by the dotted circle. Let l_m be the length of this circle, that is,

$$l_m = \pi \text{ (mean diameter of the ring in cms.)}$$

If a current of I_1 amperes is passed through this magnetising coil and if there are w_1 turns in the coil, it follows that

$$\frac{4\pi}{10} I_1 w_1 = H l_m$$

that is,

$$\begin{aligned} H &= 1.257 I_1 \frac{w_1}{l_m} \\ &= 1.257 \times \text{(ampere-turns per cm. length of the mean path)}. \end{aligned}$$

In these expressions, H gauss is the intensity of the magnetic force at every point in the mean magnetic path.

The magnetic intensity H may thus be calculated at once for any value of the exciting current I_1 .

A search coil SC of fine wire is wound over the magnetising coil and it is only necessary to wind this search coil over a small portion of the ring as shown in Fig. 89. The number of turns in the search coil will depend on the sensitivity of the ballistic galvanometer used and on the accuracy with which the test is required to be made.

The search coil is connected to the ballistic galvanometer BG through a suitable resistance R_2 of which the value is accurately known, and through a double-pole reversing switch RK . A press key K is provided by means of which the galvanometer may be short-circuited for damping purposes.

Before commencing the test, the iron ring should be completely demagnetised. In order to do this, the switch SW_2 is closed and the resistance R_1 is adjusted so that the current in the magnetising coil is about the highest value which can be safely passed without burning out the coil. The reversing switch RS is then moved backwards and forwards so that the current in the magnetising coil is reversed at the rate of about one cycle per second. Whilst operating this reversing switch, the current is gradually reduced by moving the sliding contact e along the resistance R_1 until eventually, when

this sliding contact reaches the end d the current in the coil MC will have become reduced to zero.

Having thoroughly demagnetised the specimen, the test is commenced by adjusting the current in the magnetising coil MC to a small value. The magnetisation is then carried through several complete cycles by means of the reversing switch RS , thus bringing the iron into a cyclic magnetic state, and finishing up with the reversing switch on, say, the contacts aa . During this preliminary process of bringing the iron into a cyclic magnetic state, the galvanometer key K is in the short-circuiting position as shown in the diagram.

Noting carefully the current I_1 in the magnetising coil, the galvanometer key K is pressed, the switch RS reversed on to the bb contacts, and the corresponding throw of the galvanometer is noted.

As checks on the reading, it is advisable to take four distinct galvanometer readings *for each value of the magnetising current* as follows :

(i) Reverse the switch RS several times, finishing up on the aa contacts. With the galvanometer switch RK on the ff contacts, reverse the switch RS from the aa contacts to the bb contacts and read the corresponding galvanometer deflection.

(ii) Reverse the switch RS several times, finishing up on the aa contacts. With the galvanometer switch RK on the gg contacts, throw the switch RS over from the aa contacts to the bb contacts and read the corresponding galvanometer deflection.

(iii) Reverse the switch RS several times, finishing up on the bb contacts. With the galvanometer switch RK on the ff contacts throw the switch RS over from the bb contacts to the aa contacts and read the corresponding galvanometer deflection.

(iv) Reverse the switch RS several times, finishing up on the bb contacts. With the galvanometer switch RK on the gg contacts, throw the switch RS over from the bb contacts to the aa contacts and read the corresponding galvanometer deflection.

The mean value of these four readings may be taken as the true galvanometer deflection for this value of the magnetising current.

The magnetising current is then increased to the next suitable value and after reversing the switch RS several times, the above detailed set of four galvanometer readings may be taken for this new value of the magnetising current.

In this way, the necessary readings for the complete $B:H$ curve may be taken.

After reaching the highest value of the magnetising current I_1 to which it is desired to go, readings may be taken for a series of gradually decreasing values of the magnetising current and the $B:H$ curve so obtained should be practically coincident with that obtained for the series of gradually increasing values of the magnetising current.

If θ is the mean value of the galvanometer throw for any given value I_1 of the magnetising current, it is necessary to find the logarithmic decrement λ for the galvanometer deflection. The value of λ is dependent on the value of the galvanometer resistance R_2 , and every time this resistance is altered the corresponding value of the logarithmic decrement must be determined.

If θ is the corrected value of the galvanometer deflection, that is, θ is the undamped throw, then (see § 52)

$$\theta = \theta \left(1 + \frac{\lambda}{2} \right)$$

Now since the galvanometer throws are due to the *reversal* of the current I_1 in the magnetising coil, the *flux change* in the ring to which the galvanometer throw is due will be twice the flux due to the magnetising current I_1 . That is to say, if $+\Phi$ is the flux in the ring due to the current $+I_1$ in the magnetising coil MC , then when the current is reversed from $+I_1$ to $-I_1$, the flux changes from $+\Phi$ to $-\Phi$, that is, by an amount 2Φ .

If I_1 amperes is the magnitude of the magnetising current,
 w_1 is the number of turns in the magnetising coil,
 w_2 is the number of turns in the search coil,

R_2 ohms is the total resistance of the galvanometer circuit inclusive of the resistance of the galvanometer itself,
 l_m cms. is the mean length of the magnetic circuit in the iron, that is, $\pi \times$ (mean diameter),
 A sq. cms. is the cross-sectional area of the iron circuit.

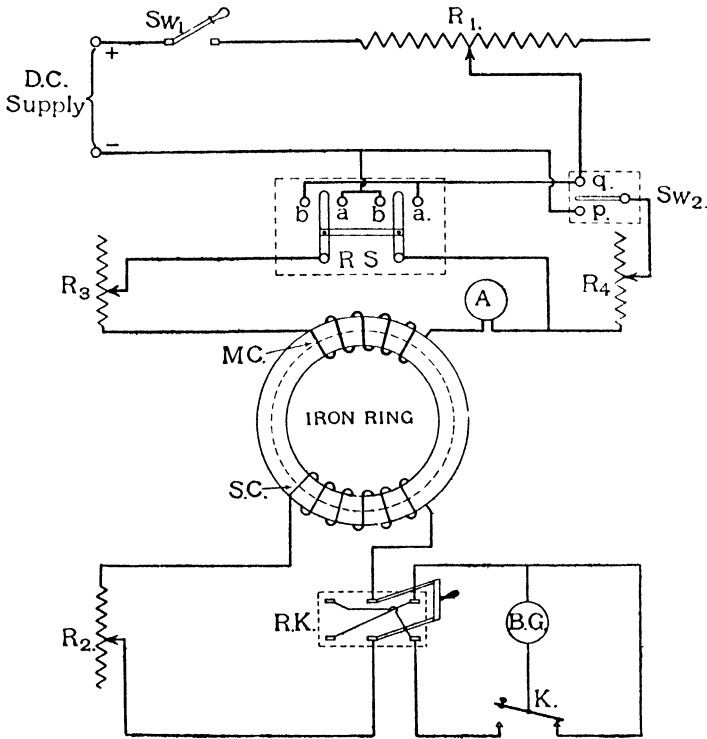

FIG. 90.

The induction B due to the magnetising current I_1 is therefore given by

$$B \times A = \Phi$$

and

$$B = \frac{bR_2 10^8}{2Aw_2} \theta \text{ lines per sq. cm.}$$

where b is the galvanometer constant (see Chapter, IV, § 53).

Also,

$$H = \frac{1.257 I_1 w_1}{l_m} \text{ gauss}$$

as explained above.

56. The Determination of the Hysteresis Loop for Iron by the Method of Reversals

The diagram of connections for this test is shown in Fig. 90. With the switching arrangements provided, the part of the loop shown by mn (Fig. 91) is obtained from one series of switching operations and the part shown by $n'l$ from another series of switching operations.

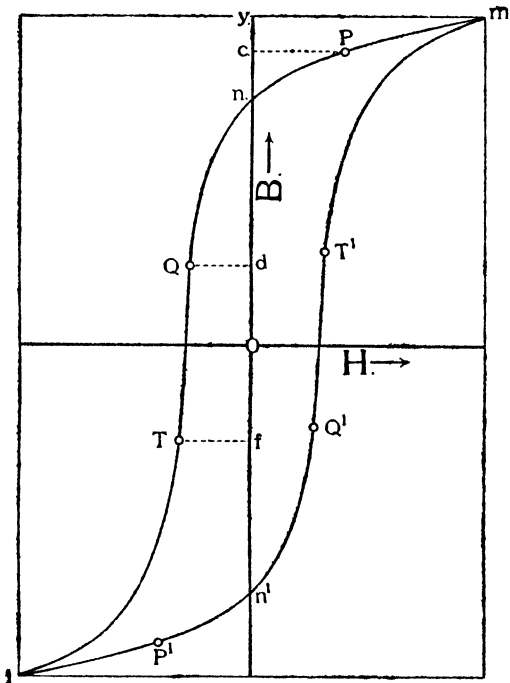

FIG. 91.

An important feature of the test is that after the readings for any point of the loop have been taken, the switching operations carry the magnetisation of the iron through a complete cycle so that the iron is maintained in a "cyclic state."

In this test a shunt switch Sw_2 is provided, by means of which a part of the current may be diverted from the magnetising coil MC . For example, when the reversing switch RS is on the contacts aa , and the shunt switch Sw_2 is open, the whole of the current from the mains passes through the magnetising coil

MC . If, however, the shunt switch is moved on to the p contact, a portion of the current is diverted from the magnetising coil MC into the shunt resistance R_4 .

Similarly, if the reversing switch RS is on the contacts bb and the shunt switch Sw_2 is on the contact q , the resistance R_4 becomes a shunt to the magnetising coil MC .

Preliminary Adjustments

- (i) With the switch Sw_2 open, place the reversing switch

RS on the *aa* contacts. By means of the adjustable resistances R_1 and R_3 set the magnetising current to give the required maximum value ym of the magnetising force H , where

$$H = 1.257 I_1 \frac{w_1}{l_m} \text{ gauss}$$

as in the previous test.

(ii) Adjust the ballistic galvanometer series resistance R_2 so that a suitable deflection of the galvanometer is obtained when the maximum value of the magnetising current is reversed by means of the reversing switch *RS*.

Switching Operations for Obtaining the Portion mn (Fig. 91) of the Hysteresis Loop

By a preliminary trial adjust the shunt resistance R_4 so that the current in the magnetising coil *MC* is reduced to the desired value, say, *cP*, Fig. 91, when the switch *Sw₂* is placed on the *p* contact, the switch *RS* being on the *aa* contacts.

- (i) Place the reversing switch *RS* on the *aa* contacts, the switch *Sw₂* being open.
- (ii) Press the galvanometer key *K*.
- (iii) Move the shunt switch *Sw₂* quickly over to the *p* contact and read the galvanometer "throw" thereby obtained.
- (iv) Release the key *K*.
- (v) Reverse the switch *RS* on to the *bb* contacts.
- (vi) Open the switch *Sw₂*.
- (vii) Reverse the switch *RS* on to the *aa* contacts, thus bringing the magnetisation of the iron ring back to the original condition given by *m*, Fig. 91.

Other points on the portion *mn* of the loop may be obtained by suitable adjustments of the shunt resistance R_4 .

Switching Operations for Obtaining the Portion nl (Fig. 91) of the Hysteresis Loop

- (i) Place the reversing switch *RS* on the *aa* contacts, the switch *Sw₂* being open.

- (ii) Place the shunt switch Sw_2 on the q contact.
- (iii) Press the galvanometer key K .
- (iv) Move the reversing switch RS sharply over on to the bb contacts and read the galvanometer "throw."
- (v) Release the key K .
- (vi) Open the shunt switch Sw_2 .
- (vii) Reverse the switch RS on to the aa contacts, thus bringing the magnetisation of the iron ring back to the original condition given by m in Fig. 91.

If the diagram of connections, Fig. 90, is traced out in conjunction with the above detailed switching operations, it will be seen that operation (iv), in conjunction with operation (ii), reverses the current in the magnetising coil from the original positive value corresponding to my , to some negative value corresponding to, say, dQ or fT .

In this way the whole curve $mPQTI$ is obtained. The half loop $lP'Q'T'm$ is then drawn as an exact copy—the point P' corresponding to P , the point Q' to Q , the point T' to T , and so on.

If θ_1 is the first "throw" of the galvanometer, and λ the value of the logarithmic decrement when the known resistance R_2 is in series with the galvanometer, then the corrected value of the galvanometer throw is

$$\theta = \theta_1 \left(1 + \frac{\lambda}{2} \right)$$

The change of flux density in the iron ring to which the "throw" is due is then, say, for the point P , Fig. 91,

$$B_m - B_P = \frac{R_2 b \theta}{Aw_2} 10^8$$

or, the flux density for the point P is

$$B_P = B_m - \left[\frac{R_2 b \theta}{Aw_2} 10^8 \right] \text{ lines per sq. cm.}$$

where B_m is the flux density corresponding to the tip m of the hysteresis loop.

Practical Note.—If the direct current supply (see Fig. 90), has its negative pole earthed, or nearly earthed, it is advisable to connect the resistance R_1 on the positive side of the supply mains. In this way, troublesome leakage currents through the galvanometer may be largely eliminated.

57. " Step-by-Step " Method

This method for determining the magnetisation curve and the hysteresis loop consists in suddenly increasing the magnitude of the current in the magnetising coil step by step, and measuring the throw of the galvanometer for each increment of the magnetising current. The specimen must be first thoroughly demagnetised, preferably by means of an alternating current of low frequency which can be very gradually reduced to zero.

For most practical purposes, this method is not so easy to carry out as the method of reversals, and, moreover, it has the disadvantage that any error made in the measurements for the low values of the magnetising current is carried right through the test. In the method of reversals, however, each point is taken independently of the others and any error made in the determination of any one point affects that one point only.

A magnetisation curve taken by the step-by-step method may differ appreciably from the curve as determined by the method of reversals in so far as low values of the magnetising force are concerned, viz., for values from $H = 0$ to about $H = 3$ to 4 gauss. For very low values of H , the magnetisation curve determined by the step-by-step method may give values of B which are some hundreds per cent. higher than the corresponding values of B obtained by the method of reversals. The reason for this is not altogether clear, but it would appear to be an example of magnetic viscosity (see Chapter IV, § 35). Further reference to this difference between the magnetisation curves as taken by the two methods is made in Chapter V, § 40.

58. The Determination of the Magnetisation Curve by the Step-by-Step Method

Having thoroughly demagnetised the specimen, suppose that, as a first step, the magnetising current is suddenly increased from zero to the value I_1 amperes, so that the value of the magnetising force is thereby suddenly increased from 0 to H_1 , and suppose that the corresponding throw of the galvanometer shows that the magnetic induction has been increased from 0 to B_1 . If the values

of H_1 and B_1 be plotted, the first point a of the magnetisation curve is obtained as shown in Fig. 92.

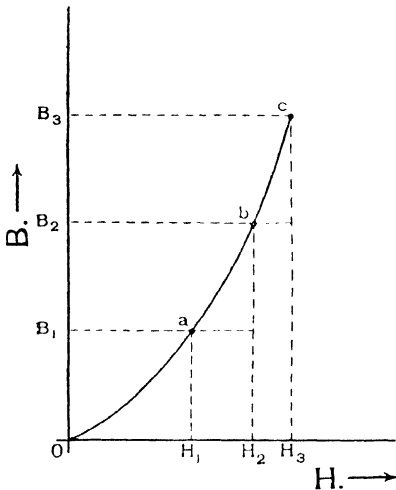

FIG. 92.

Now let the magnetising current be suddenly increased from the value I_1 amperes to I_2 amperes, the magnetising force being thereby increased from H_1 to H_2 . Let the corresponding throw of the galvanometer show that the value of the magnetic induction has been increased to B_2 , that is, an increment of $B_2 - B_1$. If this increment of the induction be plotted vertically upwards from a (see Fig. 92), and the increment of the mag-

netising force $H_2 - H_1$ be plotted horizontally from a , the next point b on the magnetisation curve is obtained.

By proceeding in this way, the whole magnetisation curve may be plotted step-by-step.

The diagram of connections is shown in Fig. 93. The specimen is shown in the form of a ring, the magnetising coil is shown at MC , and the search coil at SC . The d.c. supply, preferably a battery of accumulators, is connected through a switch Sw to a suitable resistance R_s which is provided with a number of tapping points, thus dividing the whole resistance into a series of steps which are so proportioned that the requisite increments of magnetising current may be obtained. The number and magnitude of

the resistance steps in any particular case depend upon the winding data of the magnetising coil and the search coil respectively, and also on the dimensions and magnetic quality of the specimen. It is preferable to find suitable values for the number and size of the resistance sections by means of a preliminary test.

A reversing switch RS is also provided, but for the magnetisation curve test this switch need not be operated as a reversing switch, but may remain, say, on the cc contacts. The magnetising coil MC of the specimen is connected through an ammeter Am and a series resistance R_1 and the search coil SC is connected through a series resistance R_2 to the reversing key RK of the ballistic galvanometer BG .

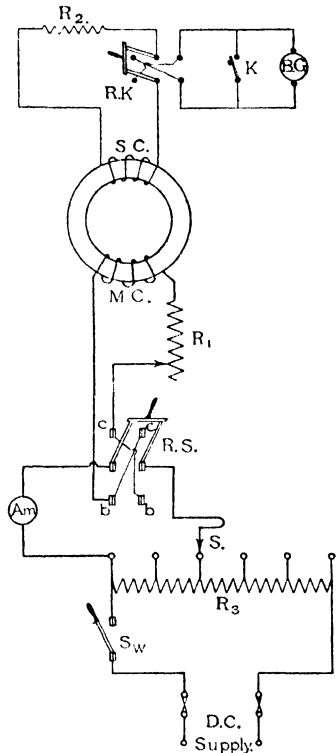

FIG. 93.

59. The Determination of the Hysteresis Loop by the Step-by-step Method

In order to obtain the hysteresis loop the following procedure may be carried out.

Having taken the magnetisation curve to the point corresponding to the value B_{max} . for which the hysteresis loop is to be obtained, the magnetising current is then suddenly reduced by moving the switch contact S ; the magnetising force is thereby reduced from the value H_{max} . to some lower value H_D , Fig. 94. The throw of the galvanometer due to this reduction of the magnetising force then gives the corresponding *change* bD in the induction and thus the point D on the hysteresis loop is obtained. To obtain another point G , the current is suddenly reduced by moving the contact arm S on to another stop, thereby reducing the magnetising force to some value H_G . The change in induction cG due to the change in the magnetising

CHAPTER XI

BAR AND YOKE METHOD OF MAGNETIC TESTING: THE BURROWS DOUBLE BAR AND YOKE PERMEAMETER

THE methods of testing considered in this chapter are suitable for a range of values of the magnetising force H up to about 300 to 400 gauss. The sample to be tested is usually in the form of a rod of about 1 cm. diameter, and about 20 to 30 cms. in length.

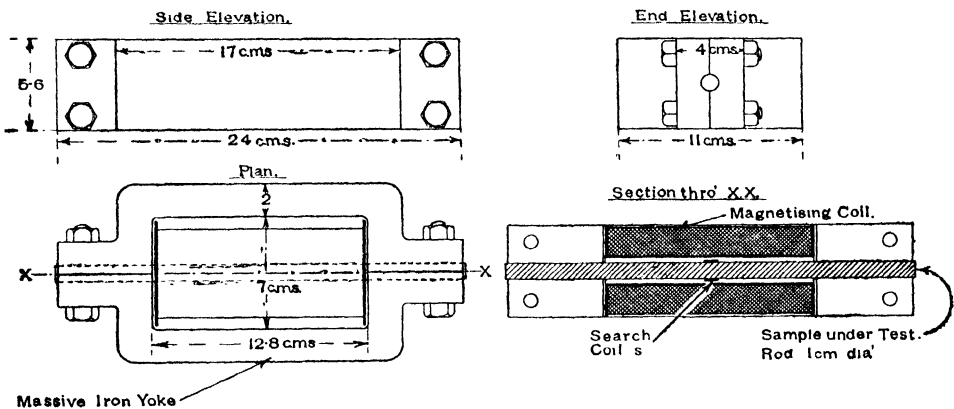

FIG. 95.

60. Bar and Yoke Method

In this method the specimen to be tested is fitted in a massive yoke which forms the return path of the magnetic circuit through the specimen.

A convenient form of yoke is one which is made in two halves and the rod which is to be tested is clamped between them. In Fig. 95 is shown a drawing of such a bar and yoke apparatus. A magnetising coil is provided and a search coil s as shown.

The magnetising coil is wound so that it is as long as the free space between the cheeks of the yoke as shown in Fig. 95.

If the magnetising solenoid were of very great length as compared with its diameter, the value of the magnetic force at the central

part of the test rod could be obtained directly from the relationship

$$\text{magnetic force} = 1.257 \left[\text{ampere-turns per cm. length of the solenoid} \right]$$

(see also Chapter IX, § 53).

In the practical form of the bar and yoke apparatus, however, the solenoid is not of sufficient length to make this relationship applicable without a correction. The correction necessary depends upon the joints between the yoke and the test piece as well as the effects of the ends of the solenoid winding itself. The following investigation shows the nature of the correction which has to be applied.

- Let w_1 be the number of turns in the magnetising coil,
 l , cms. be the free length of the specimen between the cheeks of the yoke,
 A , sq. cms. be the cross-sectional area of the specimen,
 l_y cms. be the mean length of the magnetic path in each half of the yoke,
 A_y sq. cms. be the cross-sectional area of each half of the yoke,
 μ_r be the permeability of the specimen,
 μ_y be the permeability of the yoke,
 δ cms. be the effective total length of the two air gaps at the joints between the yoke and the two clamped ends of the specimen,
 A_j sq. cms. be the total effective area of each joint between the yoke and the clamped ends of the specimen.
 H' gauss be the calculated value of the magnetising force in the specimen due to the magnetising coil,
 H gauss be the actual (*i.e.*, corrected) value of the magnetising force in the specimen,
 B lines per sq. cm. be the magnetic induction in the specimen due to the actual magnetising force H ,
 Φ be the total magnetic flux through the specimen,
 I_1 amperes be the current in the magnetising coil.

Then

$$H' = \frac{4\pi}{10} \frac{w_1 I_1}{l_r} = 1.26 \frac{w_1 I_1}{l_r}$$

and

$$\Phi = \frac{1.26 w_1 I_1}{\frac{l_r}{A_r \mu_r} + \frac{\delta}{A_g} + \frac{l_y}{2A_y \mu_y}}$$

(see, Chapter I, § 9).

also

$$\Phi = BA,$$

and

$$\mu_r = \frac{B}{H}$$

therefore

$$H = \frac{\Phi}{A_r \mu_r} = \frac{1.26 w_1 I_1}{l_r + \delta \frac{A_r \mu_r}{A_g} + l_y \frac{A_r \mu_r}{2A_y \mu_y}}$$

that is,

$$H = \frac{1.26 w_1 I_1}{l_r \left[1 + \left(\frac{\delta}{l_r} \frac{A_r}{A_g} \mu_r + \frac{l_y}{l_r} \frac{A_r \mu_r}{2A_y \mu_y} \right) \right]}$$

Writing this

$$H = \frac{1.26 w_1 I_1}{l_r (1 + K)}$$

and making use of the Binomial Theorem, it is seen that

$$H = \frac{1.26 w_1 I_1}{l_r} (1 - K) \text{ very approximately, if } K \text{ is small.}$$

Hence,

$$H = H' - H'K$$

That is to say, the actual value of the magnetising force in the specimen is *less than the value as calculated from the ampere turns of the magnetising coil per cm. length of the specimen.*

The expression for H may now be written

$$H = H' - H' \mu_r \left(\frac{\delta}{l_r} \frac{A_r}{A_g} + \frac{l_y}{l_r} \frac{A_r}{A_y} \frac{1}{\mu_y} \right)$$

In order that the assumption that K is a small quantity shall be reasonably true, the quantity in brackets must be small. Now by making the joints between the specimen and the yoke well ground and tight fitting contacts, and by having a substantial length of the rod at each end in contact with the yoke at the respective joints, the value of δ becomes small and A_g becomes large, so that the first term of the bracketed expression will be small. Further, by making the yoke of large cross-section, say $A_y = (20 \text{ to } 30) A_r$, the ratio $\frac{A_r}{A_y}$ will be small. The induction in the yoke will then be small and the permeability μ_y will remain reasonably constant, so that the expression for the magnetising force may now be written

$$H = H' - H' \mu_r C,$$

in which C is a constant.

Now the magnetic induction in the specimen will be

$$B = H' \mu_r$$

to a close degree of approximation if H' is not greatly different from H , that is, if the correction for H is small.

Hence

$$H = H' - BC \text{ very approximately,}$$

where C is a constant.

In order, therefore, to obtain the correct value of the magnetising force H from the calculated value H' , the following construction may be used: Suppose in Fig. 96 the dotted $B:H$ curve represents the relationship between B and H' . From the origin O draw the straight line OA at an angle α such that $\tan \alpha = C$. Then for any point a' on the dotted $B:H$ curve, the corresponding point a on the corrected curve is obtained by drawing a horizontal line $a'c$ parallel to the axis of H and marking off $a'a = bc$. Similarly, for any other point d' on the dotted curve, the corresponding point d on the corrected curve may be obtained by marking off $d'd = gh$.

In practice, the magnitude of the constant C may be obtained by making a test on a standard specimen of which the true $B:H$ curve has been obtained by some other method. By comparing

the $B : H$ curve as obtained on the standard specimen by means of the bar and yoke apparatus and the correct curve as obtained by some standard method, for example the Burrows' Permeameter (see § 61, below), the slope of the line OA in Fig. 96 is at once determined, and can then be recorded as a constant of the apparatus.

61. The Burrows Double Bar and Yoke Permeameter

This apparatus has been described by C. P. Burrows in the Bulletin of the Bureau of Standards, Vol. VI, No. 1, Reprint No. 117. It comprises, in addition to the rod under test, a second rod of dimensions similar to those of the test-piece. Each rod is provided with a magnetising solenoid. The two solenoids are precisely similar to one another and are arranged side by side, the projecting ends of the two rods being clamped between heavy iron yokes.

This type of permeameter has been used by T. D. Yensen for a large number of experiments and the detailed information of the apparatus as used in

those experiments is given in Bulletin No. 72, Engineering Experimental Station, University of Illinois. The data given in the following, as well as the corresponding drawings, have been prepared from the information contained in that report.

In Fig. 97 is shown the permeameter in elevation and part sectional plan. The specimen to be tested is shown at T as a rod 1 cm. diameter, and about 30 cms. long. The magnetising solenoid for the specimen is shown at S . The magnetic circuit through the test-piece T is completed through the massive yokes Y and through a second rod X which is of the same dimensions as the test-piece T .

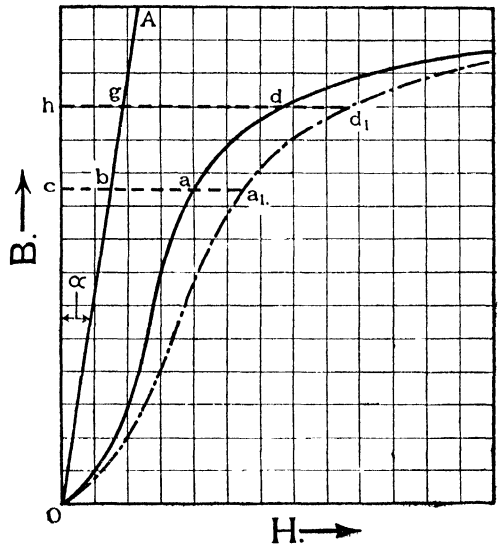

FIG. 96.

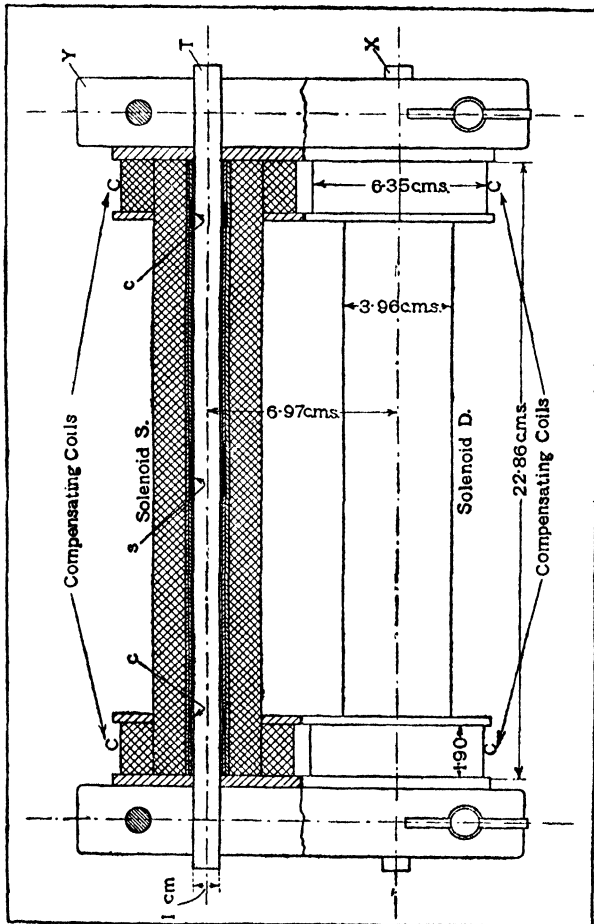
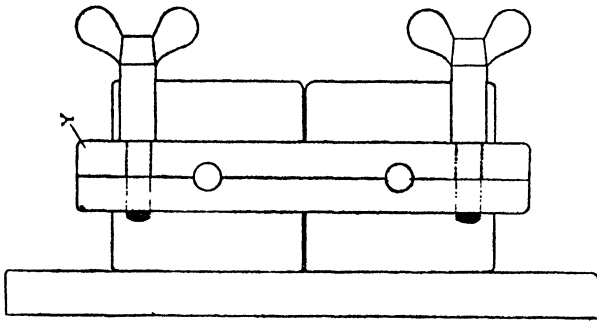

FIG. 97.

The solenoid *D* through which the rod *X* passes is precisely similar in size and winding data to the solenoid *S*.

Four compensating coils *C* are connected in series with each other and arranged at the respective ends of the solenoids *S* and *D*, as shown in Fig. 97. The four coils *C* are excited from an independent battery and each of the solenoids *S* and *D* is also excited from an independent battery, as shown in Fig. 98.

Search coils are provided and arranged as follows :

(i) A main search coil *s* which is used for measuring the flux through the test-piece *T*. This coil has 126 turns of No. 30 B. & S. gauge (*i.e.*, 0.01 in. diameter bare) double silk-covered copper wire.

(ii) Two equal search coils *c*, ar-

ranged one at each end of the solenoid S . Each of these search coils has 63 turns of No. 30 B. & S. gauge double silk-covered copper wire.

(iii) A search coil d situated at the central part of the solenoid D and close to the rod X . This search coil has 126 turns and is precisely similar in every respect to the search coil s .

An essential feature of the use of this permeameter is that the necessary adjustments shall be made to ensure that the flux through each of the search coils s , c and d is the same. This adjustment is to be made each time that a reading of the flux through the test-piece T is required.

Having obtained this adjustment, it is permissible to assume that the magnetic flux is the same throughout the magnetic circuit of the permeameter. That is to say, no corrections are necessary to allow for leakage (and consequent free magnetism) at the joints between the yokes and the rod T and also between the yokes and the rod X .

It is, however, desirable to calculate the effect of the two ends of each of the solenoids S and D and also the four ends of each of the compensating coils C , on the magnetic intensity at the point O (see Fig. 99) in the test-piece, viz., at the central part of the test-piece through which the induction B is to be measured from the reading of the search coil s .

The determination of the magnetic intensity H at, and in the neighbourhood of, the point O (Fig. 99) is obtained from the expression

$$H = \frac{4\pi w}{10l} I$$

where w is the total number of turns in the winding of the solenoid S ,
 l cms. is the length of the solenoid S ,
 and I amperes is the current in the solenoid S .

This result is true for an infinitely long solenoid (see also Chapter IX, § 53). For a solenoid of finite length a correction is necessary. Since there are four compensating coils C and one solenoid D in

addition to the solenoid S , it is necessary to ascertain the correction to be applied to the expression for H so that the effects of the ends of all these coils may be obtained.

The method of determining these corrections is given in § 62 below, but as it is found that the resultant correction is very small with this design of the permeameter, it may be neglected in most cases.

The calibration of the galvanometer is made by means of a mutual induction as explained in § 63 below.

Each of the solenoids S and D has 10 layers with 7·875 turns per cm. in each layer, of No. 18 B. & S. gauge (*i.e.*, diameter bare, 0·0403 in. double cotton-covered copper wire. There are thus 78·75 turns per cm. length of the solenoid winding, so that $\frac{w}{l} = 78\cdot75$, and hence

$$H = \frac{4\pi}{10} 78\cdot75 I$$

that is,

$$H = 99 I \text{ gauss}$$

I. *To Determine the Magnetisation Curve.*—The diagram of connections is given in Fig. 98. In this test, the switches Sw_s , Sw_d and Sw_c are kept closed throughout.

The first procedure is to ensure that the magnetic flux through each of the search coils s , d and c is the same for a given value of the magnetising force H within the specimen.

With a known value of the current in the magnetising solenoid S , and with the galvanometer switch Sw_g on the contact d , thus placing the two search coils s and d in opposition, the current in the solenoid D can be so adjusted that when the switches RS_s and RS_d are reversed, there will be no throw on the ballistic galvanometer. In order to increase the sensitivity of the galvanometer for this test, the series resistance may be short-circuited by the key k_2 . Since the number of turns in each of the coils s and d is the same, it follows that the flux is the same through each of these search coils when the galvanometer shows no deflection on the reversal of the current in the two solenoids S and D .

Next, by placing the galvanometer switch Sw_G on the contact c , the search coil s is placed in opposition to the search coils c (see Fig. 98). The current in the compensating coils C is then adjusted so that on reversal of the switches RS_S, RS_D, RS_C , there is no throw

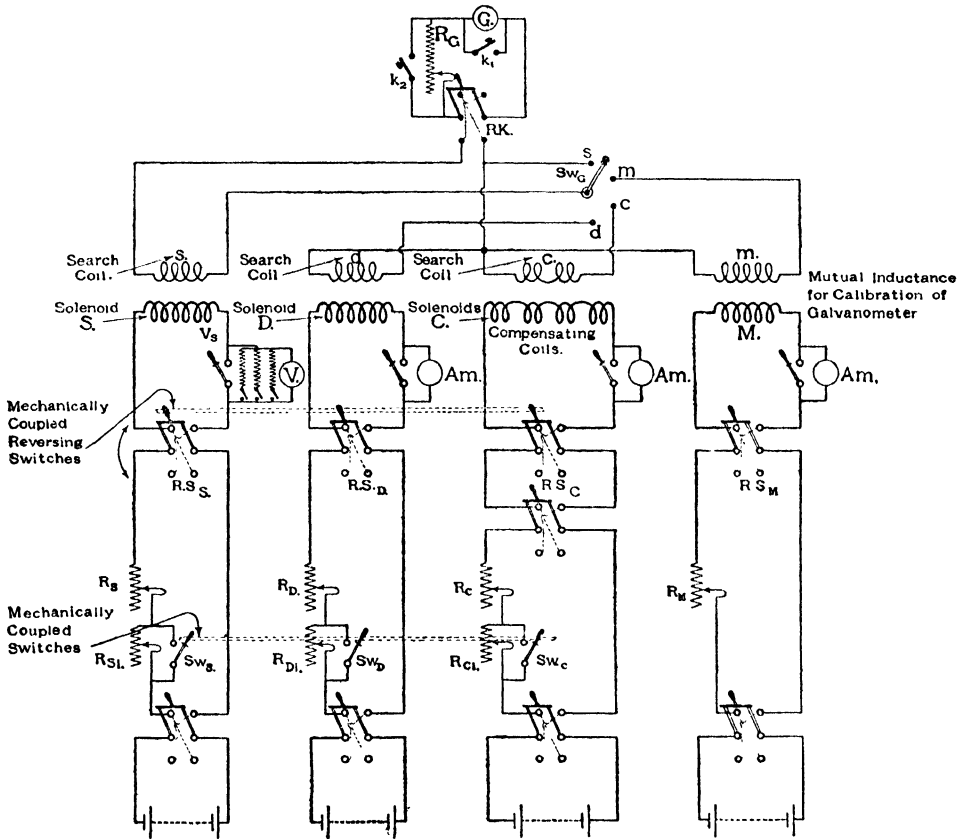

on the galvanometer. Since the total number of turns in the two search coils c is the same as the number of turns in the search coil s , the flux through all these coils will be the same when reversal of the currents in the coils C and the solenoid S gives no deflection of the galvanometer.

Before taking a reading of the throw given by the search coils in order to obtain the value of B , the coupled set of switches $RS_S,$

RS_D , RS_C should be reversed a number of times in order to ensure that the iron has been magnetised to a true cyclic condition. After this has been done, check readings should be taken with the galvanometer switch Sw_G on the contacts d and c , respectively, to ensure that the total magnetic flux through all the search coils is the same before an actual reading of the magnitude of the flux through the search coil s is made.

Instead of reading the current in the solenoid winding S by means of an ammeter, a shunted millivoltmeter is used as shown in Fig. 98. Three shunts are provided, each with a separate switch. The three shunts are so adjusted that if the shunt switch number 1 is closed, the reading of the millivoltmeter is equal to $10H$, if the shunt switch number 2 is closed, the reading of the millivoltmeter is equal to H , whilst if the shunt switch number 3 is closed, the reading of the millivoltmeter is equal to $0.25 H$.

Having made all the necessary adjustments, the galvanometer switch Sw_G is placed on the contact s and the galvanometer throw measured when the switches RS_S , RS_D and RS_C are reversed.

All the switching operations requisite for taking the magnetisation curve of the specimen are performed by the use of rocking mercury switches.

By means of this permeameter it is possible to determine the magnetisation curve for values of H up to about 300 to 400 gauss.

II. *To Determine the Hysteresis Loop.*—For this test, the switches Sw_S , Sw_D , Sw_C are brought into operation. Let H_{\max} be the value of the magnetising force corresponding to the tip of the hysteresis loop which it is desired to trace. The switches Sw_S , Sw_D , Sw_C are, in the first place, kept closed and the resistance R_s is adjusted so that the current in the solenoid S gives the required value of H_{\max} . The resistances R_D and R_C are then adjusted so that the flux is the same throughout the magnetic circuit as tested by the search coils s , d and c , as before. Each time an alteration of one of these resistances is made, and before making the test with the search coils s , d and c , the reversing switches RS_S , RS_D , and RS_C should be operated several times in order to ensure that the iron circuit is in a cyclic

magnetic condition. The settings of the resistances R_s , R_d , and R_c are then left unaltered throughout the measurements for the points on the loop.

Suppose that it is desired to determine a point such as P (Fig. 91) on the loop for some value of the magnetising force H_p which is between O and H_{\max} . The switch Sw_s is opened and adjustment of the resistance R_{s1} is made so that the current in the solenoid S corresponds to the value H_p for the required point P on the loop (Fig. 91). With the switches Sw_s , Sw_d and Sw_c closed, the reversing switches are operated several times to bring the magnetic circuit into the cyclic state.

Adjustment of the resistance R_{d1} is then made so that, with the search coils s and d in opposition, no throw of the galvanometer is obtained when the switches Sw_s , Sw_d and Sw_c are suddenly opened. Similarly, adjustment of the resistance R_{c1} is made so that there is no galvanometer throw when the switches Sw_s , Sw_d and Sw_c are suddenly opened. After each adjustment of the resistances, the switches Sw_s , Sw_d and Sw_c are closed and the hysteresis loop is passed through several times by means of the reversing switches RS_s , RS_d and RS_c before making the test with the search coils s , d and c .

Having made the necessary adjustments as described, and the switches Sw_s , Sw_d and Sw_c being closed, the galvanometer switch Sw_g is placed on the contact s , and the galvanometer throw is observed when the switches Sw_s , Sw_d and Sw_c are simultaneously opened.

In order to obtain points on the hysteresis loop between n and l (Fig. 91), the reversing switches RS_s , RS_d and RS_c are thrown over simultaneously with the opening of the switches Sw_s , Sw_d and Sw_c , the preliminary adjustments being precisely the same as before. In this way, the value of the magnetising force is changed from H_{\max} to some negative value, e.g., fT (Fig. 91), thus giving a point T on the hysteresis loop. The tip l of the loop (Fig. 91) is of course obtained from the throw of the galvanometer when the switches Sw_s , Sw_d and Sw_c are kept closed and the switches RS_s , RS_d and RS_c are thrown over.

62. Corrections for the End Effects of the Main Solenoids *S* and *D* and for the Four Compensating Coils *C* of the Burrows Permeameter

The value of the magnetic force at the centre *O* within a solenoid core is

$$H = \frac{4\pi}{10} \frac{w}{l} I \text{ gauss}$$

if the length *l* of the solenoid is great as compared with its diameter.

In this expression, the solenoid winding is assumed to be uniform throughout the entire length and is wound with a total of *w* turns,

i.e., w/l turns per cm. of its length. The current in the solenoid winding is *I* amperes.

When the solenoid is of finite length, this expression requires a correction to obtain the true value of *H* at the central part within the core of the solenoid. For example, the ends of the solenoid produce an effect

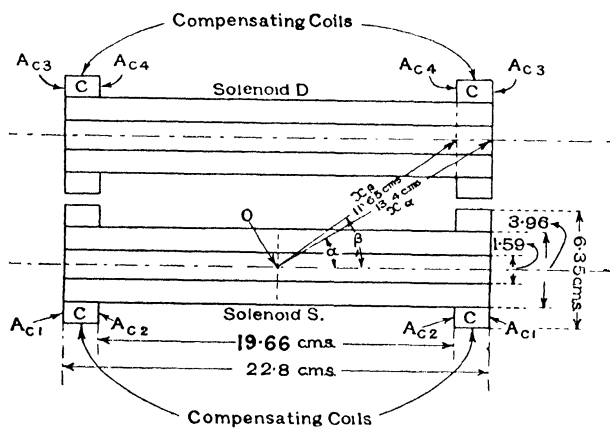

Fig. 99

at a point *O* within the core, similar to that produced by the poles of a bar magnet at a point within the magnet, that is to say, a demagnetising effect is produced (see Chapter I, § 9). The correction coefficient for a solenoid which is not of indefinitely great length is given in Chapter IX, § 53.

In the following, the corrections for the value of *H* will be found not only in respect of the solenoid *S*, but also in respect of the solenoid *D* and the four compensating coils *C*.

Referring to Fig. 99, the data necessary for calculating each of the specified corrections are given. The correction in respect of the ends of the solenoid *D* is given in a form different from that previously

given in Chapter IX and the two forms of this correction factor should be compared as, of course, they should be found to lead to the same result.

(i) *Correction Due to the Two End A_s of the Solenoid S .*—

Let r cms. be the mean radius of the winding of the solenoid S ,

l ,, be the overall length of the solenoid winding,

$$\tan \delta = \frac{r}{l/2} = \frac{2r}{l}.$$

The correction to the value of H at the centre O of the solenoid S due to each end is

$$\frac{1}{2}A_s = -\frac{1}{2}(1 - \cos \delta) H$$

That is to say, the effect of each end is to *decrease* the magnitude of the magnetic force, as calculated for a very long solenoid, by the amount $\frac{1}{2}A_s$, so that the total correction for the two ends of the solenoid S is

$$A_s = -(1 - \cos \delta)H$$

Now

$$\cos^2 \delta = \frac{1}{1 + \tan^2 \delta}$$

so that,

$$\cos \delta = (1 + \tan^2 \delta)^{-\frac{1}{2}}$$

that is,

$$\cos \delta = (1 - \frac{1}{2} \tan^2 \delta + \frac{3}{8} \tan^4 \delta - \frac{5}{16} \tan^6 \delta + \dots)$$

Hence, the correction for the two ends of the solenoid S is

$$A_s = -H(\frac{1}{2} \tan^2 \delta - \frac{3}{8} \tan^4 \delta + \frac{5}{16} \tan^6 \delta - \dots)$$

that is,

$$A_s = -H \left[\frac{1}{2} \left(\frac{2r}{l} \right)^2 - \frac{3}{8} \left(\frac{2r}{l} \right)^4 + \frac{5}{16} \left(\frac{2r}{l} \right)^6 - \dots \right]$$

Taking as an example, the numerical data given in Figs. 97 and 99, viz. :

$$2r = \frac{1}{2} (3.96 + 1.59) = 2.77 \text{ cms. } l = 22.8 \text{ cms.}$$

$$\frac{2r}{l} = 0.121 : \left(\frac{2r}{l} \right)^2 = 0.0147 : \left(\frac{2r}{l} \right)^4 = 0.000216$$

The total specified correction for both ends is therefore

$$\Delta_s = - 0\cdot0072 H.$$

(ii) *Correction Due to the Two Ends A_D of the Solenoid D.*—The effect of the ends of the solenoid *D* on the magnetic intensity at *O* is opposite to that of the ends of the solenoid *S*. That is to say, the ends of the solenoid *D* increase the magnetic intensity at *O*. The magnitude of the total correction due to the two ends of the solenoid *D* may be expressed as follows :

$$\Delta_D = + H \left[\frac{1}{2} \left(\frac{r}{x_a} \right)^2 P_1 - \frac{3}{8} \left(\frac{r}{x_a} \right)^4 P_3 + \frac{5}{16} \left(\frac{r}{x_a} \right)^6 P_5 - \dots \right]$$

where x_a cms. is the distance of the centre of the end of the solenoid *D* from the point *O* (see Fig. 99), and r cms. is the mean radius of the winding of the solenoid *D*. The two solenoids *S* and *D* are identical in every respect, so that

$$r = 1\cdot38 \text{ cms. as before :}$$

also

$$x_a = 13\cdot4 \text{ cms.}$$

and hence,

$$\left(\frac{r}{x_a} \right)^2 = 0\cdot0106 : \left(\frac{r}{x_a} \right)^4 = 0\cdot00012$$

The quantities P_1, P_3, P_5, \dots are the zonal harmonics of $\cos \alpha$ (see Fig. 99).

Now

$$\alpha = 31\cdot5^\circ$$

$$\cos \alpha = 0\cdot8526$$

$$P_1 = \cos \alpha = 0\cdot8526,$$

$$P_3 = \frac{\cos \alpha}{2} (5 \cos^2 \alpha - 3) = 0\cdot426 (3\cdot64 - 3) = 0\cdot275$$

$$\begin{aligned} P_5 &= \frac{\cos \alpha}{8} (63 \cos^4 \alpha - 70 \cos^2 \alpha + 15) \\ &= 0\cdot106 (63 \times 0\cdot53 - 70 \times 0\cdot73 + 15) \\ &= 0\cdot106 (33\cdot4 - 51\cdot1 + 15) = 0\cdot106 (- 2\cdot7) = - 0\cdot286 \end{aligned}$$

therefore

$$\begin{aligned} \Delta_D &= + H \left[\frac{1}{2} \times 0\cdot0106 \times 0\cdot8526 - \frac{3}{8} \times 0\cdot000112 \times 0\cdot275 + \dots \right] \\ &= + H 0\cdot0045 \end{aligned}$$

(iii) *Correction Due to the Two Ends A_{c1} of the Compensating Coils C.*—Referring to Fig. 99, it will be noticed that the two ends A_{c1} of the compensating coils C situated on the solenoid S produce a *weakening* effect on the magnetic force at O . The magnitude of this effect is obtained in a similar manner to that due to the ends of the solenoid S .

Let r_c cms. be the mean radius of the winding of the compensating coils C ,

„ $\frac{l}{2}$ cms. be the distance of the ends A_{c1} from the point O ,

then the total amount of the correction due to the two ends A_{c1} is

$$\Delta_{A_{c1}} = - H \left[\frac{1}{2} \left(\frac{2r_c}{l} \right)^2 - \frac{3}{8} \left(\frac{2r_c}{l} \right)^4 + \dots \right]$$

But

$$2r_c = \frac{1}{2} (6.35 + 3.96) = 5.15 \text{ cms.}$$

and

$$l = 22.8 \text{ cms.}$$

therefore

$$\left(\frac{2r_c}{l} \right)^2 = 0.051$$

$$\left(\frac{2r_c}{l} \right)^4 = 0.0026$$

and hence,

$$\Delta_{A_{c1}} = - H(0.0255 - 0.000975)$$

that is

$$\Delta_{A_{c1}} = - 0.0245 H$$

(iv) *Correction Due to the Two Ends A_{c2} of the Compensating Coils C.*—This correction is positive, that is, the effect is to increase the intensity of the magnetic field at O , Fig. 99.

If $l_c/2$ cms. be the distance of O from each of the ends A_{c2} , that is, in this case $l_c = 18.6$ cms., the total correction due to these two ends is

$$\Delta_{A_{c2}} = + H \left[\frac{1}{2} \left(\frac{2r_c}{l_c} \right)^2 - \frac{3}{8} \left(\frac{2r_c}{l_c} \right)^4 + \dots \right]$$

but

$$\left(\frac{2r_c}{l_c}\right)^2 = \left(\frac{5.15}{18.6}\right)^2 = 0.077$$

$$\left(\frac{2r_c}{l_c}\right)^4 = 0.0059$$

therefore,

$$\begin{aligned} \Delta_{A_{02}} &= + H[0.0385 - 0.00221] \\ &= + \mathbf{0.0363 H} \end{aligned}$$

(v) *Correction Due to the Two Ends A_{c3} of the Compensating Coils C.*—The correction due to these two ends is again positive, that is, the intensity of the magnetic force at O is increased, due to the effect of these two ends. The magnitude of the total correction is

$$\Delta_{A_{03}} = + H \left[\frac{1}{2} \left(\frac{r_c}{x_a}\right)^2 P_1 - \frac{3}{8} \left(\frac{r_c}{x_a}\right)^4 P_3 + \dots \right]$$

where

$$\begin{aligned} x_a &= 13.4 \text{ cms.}, & r_c &= 2.57 \text{ cms.} \\ \left(\frac{r_c}{x_a}\right)^2 &= 0.037 & : & \left(\frac{r_c}{x_a}\right)^4 = 0.00137 \end{aligned}$$

and P_1, P_3, \dots are the zonal harmonics of $\cos \alpha$.

Now the angle α in this case is equal to 31.5° and hence,

$$P_1 = \cos \alpha = 0.8526$$

$$P_3 = \frac{\cos \alpha}{2} (5 \cos^2 \alpha - 3) = 0.275$$

The magnitude of the total correction due to these two ends is therefore

$$\begin{aligned} &= + H \left[\frac{1}{2} \times 0.037 \times 0.8526 - \frac{3}{8} \times 0.00137 \times 0.275 + \dots \right] \\ &= + \mathbf{0.0156 H} \end{aligned}$$

(vi) *Correction Due to the Two Ends A_{c4} of the Compensating Coils C.*—The correction due to these two ends is negative, that is, the effect is to *weaken* the intensity of the magnetic force at O . The amount of this correction is

$$\Delta_{c4} = - H \left[\frac{1}{2} \left(\frac{r_c}{x_\beta}\right)^2 P_1 - \frac{3}{8} \left(\frac{r_c}{x_\beta}\right)^4 P_3 + \dots \right]$$

where

$$r_c = 2.57 \text{ cms.}, \quad x_\beta = 11.65 \text{ cms.}$$

$$\left(\frac{r_c}{x_\beta}\right)^2 = 0.0488 \quad : \quad \left(\frac{r_c}{x_\beta}\right)^4 = 0.00239$$

and P_1, P_3, \dots are the zonal harmonics of $\cos \beta$ (see Fig. 99).

Now

$$\beta = 37.0^\circ$$

$$\cos \beta = 0.7986$$

$$P_1 = \cos \beta = 0.7986$$

$$P_3 = \frac{\cos \beta}{2} (5 \cos^2 \beta - 3) = 0.0755$$

The total amount of this correction is therefore

$$\begin{aligned} \Delta_{c_4} &= H \left[\frac{1}{2} \times 0.049 \times 0.798 - \frac{3}{8} \times 0.0024 \times 0.0755 + \dots \right] \\ &= -H(0.0196 - 0.000068) \\ &= -\mathbf{0.01953 H} \end{aligned}$$

The total amount of the correction due to the twelve ends $A_S, A_D, A_{C1}, A_{C2}, A_{C3}, A_C$ is therefore

$$\Delta = (\Delta_S + \Delta_D) + (\Delta_{A_{C1}} + \Delta_{A_{C2}} + \Delta_{A_{C3}} + \Delta_{A_C})$$

that is

$$\begin{aligned} \Delta &= +H [(-0.0072 + 0.0045) + (-0.0245 + 0.0363 + 0.0156 - \\ &\quad 0.0195)] \\ &= +\mathbf{0.0052 H} \end{aligned}$$

In determining the magnitude of the total correction due to the eight ends $A_{C1}, A_{C2}, A_{C3}, A_{C4}$ of the compensating coils C , viz. : $+0.0079 H$, it has been assumed that the same current flows through these coils as through the solenoids S and D . If the current in the compensating coils is y times the current in the solenoids S and D , the amount of the correction due to these ends of the compensating coils will be y times as great as the value given above, that is, the correction will be in this case $+y(0.0079 H)$.

From tests made with the permeameter detailed in Figs. 97 and 99, it has been found by T. D. Yensen that for a magnetic specimen having the highest values of permeability commonly found the

current in the compensating coils C may be 5 times as large as the current in the main solenoids S and D . The maximum value of the total correction, therefore, that is likely to be necessary in determining the magnitude of the magnetic force H at the central part O of the solenoid S is

$$= - (0.0027 + 0.0395) H$$

$$= + 0.037 H$$

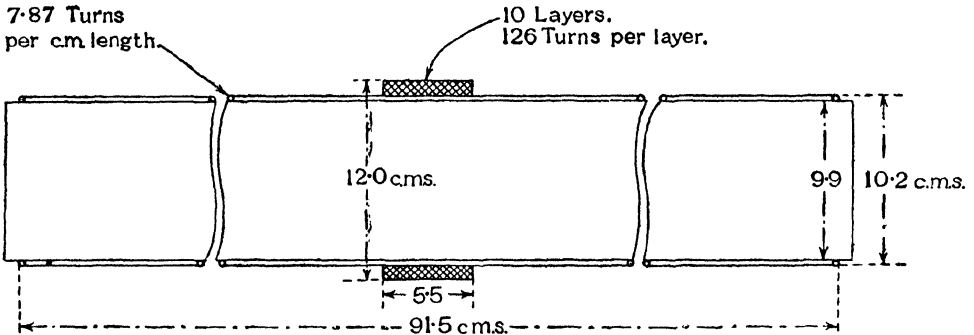

FIG. 100.

It is therefore clear from these results that for ordinary iron the value of the magnetic force H at the central part O of the solenoid S as calculated from the relationship

$$H \frac{4\pi}{10} \frac{w}{l} I$$

is correct to about 0.5%, whilst for the highest permeability iron the error is under 4%. The error in each case is such that the value of H as calculated from the expression $\frac{4\pi}{10} \frac{w}{l} I$ is *too small*.

63. Calibration of the Ballistic Galvanometer for the Burrows Permeameter Test

The ballistic galvanometer is calibrated by means of the mutual inductance shown in Fig. 100. The primary winding has, per cm. length, 7.87 turns of copper wire No. 18 B. & S. gauge, and the secondary winding consists of 10 layers of 126 turns per layer of copper wire No. 30 B. & S. gauge. The total number of turns in the secondary winding is therefore 1260.

If a current of I_p amperes is sent through the primary winding, the value of the magnetic force at the central part within the primary winding will be

$$H = \frac{4\pi}{10} 7.87 I_p \text{ gauss,}$$

if the length of the solenoid is great compared with its diameter.

As the actual solenoid is not of very great length (see Fig. 100), it is necessary to obtain the correction due to the ends of the solenoid. This is found in a precisely similar manner to that in which the correction was found for the ends of the solenoid S in the permeameter (Figs. 97 and 99).

For the data given in Fig. 100 the total correction for the two ends of the primary winding of the mutual inductance is

$$\Delta = -H \left[\frac{1}{2} \left(\frac{10.05}{91.5} \right)^2 - \frac{3}{8} \left(\frac{10.05}{91.5} \right)^4 + \dots \right]$$

or

$$\begin{aligned} \Delta &= -H \left[\frac{1}{2} 0.012 - \frac{3}{8} 0.000144 + \dots \right] \\ &= -0.006 H. \end{aligned}$$

Thus the magnitude of the actual intensity at the central part within the windings of the mutual inductance will be

$$\begin{aligned} H &= \frac{4\pi}{10} I_p 7.87 (1 - 0.006) \text{ gauss,} \\ &= 9.83 I_p \text{ gauss.} \end{aligned}$$

The magnetic flux threading the secondary winding will be

$$\Phi_{sc} = 9.83 I_p A_p \text{ lines,}$$

where A_p sq. cms. is the effective cross-sectional area of the primary winding. In this case,

$$A_p = \frac{\pi}{4} \times 10.05^2 = 79.3 \text{ sq. cms.,}$$

so that

$$\begin{aligned} \Phi_{sc} &= 9.83 \times 79.3 \times I_p, \\ &= 780 I_p. \end{aligned}$$

Since there are 1260 turns in the secondary winding, the flux-linkages of the secondary winding will be

$$1260 \Phi_{sc} = 1260 \times 780 I_p = 983,000 I_p.$$

If the galvanometer throw is measured when the current I_P in the primary winding is *reversed*, and if θ_e is the magnitude of the corresponding deflection as corrected for damping (see Chapter IX, §§ 52 and 53), then the deflection θ_e corresponds to

$$\begin{aligned} & 2 (983,000 I_P) \\ & = 1.966 \times 10^6 \times I_P \text{ flux-linkages,} \end{aligned}$$

or a deflection of one division of the galvanometer scale corresponds to

$$\left(\frac{1.966 \times 10^6}{\theta_e} I_P \right) \text{ flux-linkages.}$$

Then, if the induction in the test-piece is B lines per sq. cm. and the cross-section of the test piece is A_s sq. cms., and if the galvanometer corrected deflection is θ when the current in the magnetising solenoid S of the permeameter is reversed, the flux-linkages will be

$$2 B \times A_s \times 126 = \left(\frac{1.966 \times 10^6}{\theta_e} I_P \right) \theta,$$

since there are 126 turns in the search coil s . This relationship assumes that the galvanometer resistance R_G (Fig. 98) is the same when the calibrating deflection θ_e is obtained as when the deflection θ due to the reversal of the magnetising current in the solenoid S is measured.

Hence

$$B = \left(\frac{1.966 \times 10^6}{\theta_e} \right) \frac{I_P}{2A_s \times 126} \theta$$

or

$$B = 9995 I_P \frac{\theta}{\theta_e},$$

since the diameter of the specimen is 1 cm. and the cross-sectional area therefore

$$\begin{aligned} A_s &= \frac{\pi}{4} \times 1.0^2 \\ &= 0.785 \text{ sq. cm.} \end{aligned}$$

MAGNETIC TESTING IN INTENSE FIELDS

THE methods for magnetic testing hitherto described refer to the condition that the magnetising force is not greater than about 500 gauss.

If it is desired to make tests in more intense fields, other methods or suitable modifications of the foregoing methods must be used. In the present chapter reference will be made to three such methods.

64. I. Ewing's Isthmus Method

This was the first method by means of which intense magnetic fields could be produced, and Ewing applied the method in carrying out a number of his classical researches.

The magnetic field is provided by means of a powerful electro-magnet. The pole pieces are made in a conical form and the apex of each cone butts on the specimen. The specimen thus forms a thin neck or "isthmus" between the pole pieces, and a very intense magnetic force is thereby produced in the specimen. In one of the electro-magnets used by Ewing, the neck was 2.6 mms. in diameter, and 3.5 mms. long. A magnetic force of $H = 24,500$ was obtained in this way.

More recently, Hadfield and Hopkinson * have used the method for testing iron and its alloys in intense magnetic fields.

One of the magnets used by them is shown in Fig. 101, the specimen being seen as a small rod (usually about 5 mms. in dia-

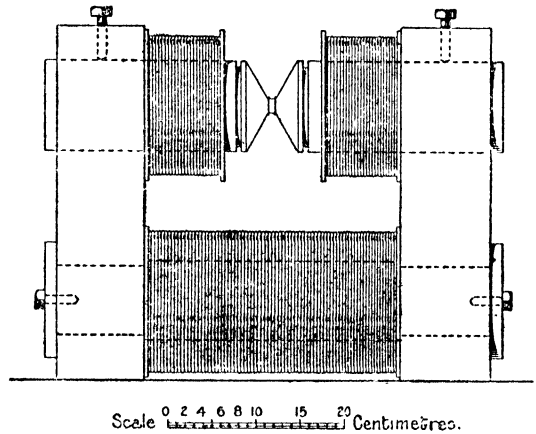

FIG. 101.

* See *Journal of Institution of Electrical Engineers*, 1911, Vol. XLVI, p. 235: "The Magnetic Properties of Iron and its Alloys in Intense Fields."

meter) forming the neck or "isthmus" between the conical-shaped pole pieces.

The general details and dimensions of the electro-magnet are as follows: The vertical limbs are of rectangular section, 10 cms. by 20 cms. The pole pieces are cylindrical and are made a good fit in holes at the top of the vertical limbs, so that they can slide axially and be clamped in any position by means of set screws. The yoke is wound with about 1600 turns and each pole piece with about 400 turns of No. 14 s.w.g. wire.

For producing the highest fields the magnet was fitted with the pair of pole pieces shown in Fig. 101. With the tips of these $\frac{1}{4}$ in. apart, and with a current of 30 amperes passing in the coils of the magnet, the two parts of which were placed in parallel, a field of about 22,000 gauss could be obtained in the space between the flat ends of the pole pieces. The distribution of the field was determined by means of concentric annular test coils and was found to be constant within 1% over a circle of 2.5 mms. radius. By increasing the current to 60 amperes, which, however, could only be kept on for a short time, the intensity of the field could be increased to 25,000 gauss.

Lower fields ranging up to 10,000 gauss were obtained by replacing the conical pole pieces shown in Fig. 101 by a pair of flat pole pieces having flat faces 1 in. square. With these placed $\frac{1}{4}$ in. apart with their faces parallel, a uniform field of about 7,000 gauss was produced over an area 20 mms. square with a current of 5 amperes in the magnet coils.

The material was for the most part in the form of rods about 5 mms. diameter. The magnetic test-pieces were turned down from these rods into little cylinders $\frac{1}{8}$ in. diameter. They were, in most cases, $\frac{1}{4}$ in. long.

The testing coil consisted of 16 turns of s.w.g. No. 38 wire wound on a brass bobbin which just fitted over the test-piece. A second coil, also of 16 turns, was wound outside the first with a layer of paper between the surfaces, to measure the magnetising force in the neighbourhood of the specimen. The effective areas of the test-coils

were determined by magnetic measurements as follows: The flat pole pieces were fixed in position about $\frac{1}{4}$ in. apart, and a coil of 12 turns, wound on a brass former about 15 mms. diameter, was inserted between them. The galvanometer throw obtained with this coil when a current of about 5 amperes was reversed in the magnet coils was observed. The test-coil was then inserted and the galvanometer throw measured with exactly the same exciting current in the magnet coils. The area of the larger coil could be accurately calculated from its dimensions and that of the smaller coil deduced from the ratio of the galvanometer throws after reducing them to the same resistance in the galvanometer circuit.

65. II. Gümlich's Method for Magnetic Testing in Fields up to $H = 6,000$

The general arrangement of the apparatus for this method is shown in Fig. 102.

A ring yoke *YR* (Fig. 102) is fitted with pole pieces *PP* of soft iron and arranged dia-

metrically opposite to each other. Each pole piece is 25 mms. in diameter and the distance apart is 12 mms. The inner end of each pole piece is bored with a hole of 6 mms. diameter to a depth of about 6 mms.

The specimen *T* which is to be tested is fitted in these holes as shown in Fig. 102. The magnetising coil is shown at *M*. A search coil *SC* is provided and is arranged at the central part of the specimen and comprises 4 coils, each of which consists of one layer of 40 turns of silk-covered copper wire. The respective coils are separated by layers of paper. A diagrammatical sketch of the search coils is shown in Fig. 103, in which the approximate dimensions are also given.

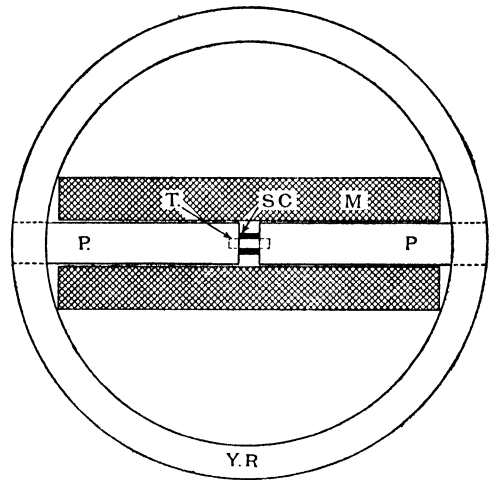

FIG. 102.

The test comprises (i) the measurement of the magnetic intensity H , and (ii) the measurement of the magnetic induction B .

(i) *The Measurement of the Magnetic Intensity H.*—

Let the search coils be numbered 1, 2, 3 and 4, respectively.

The value of the intensity H for any given value of the magnetising current is measured by connecting the search coils

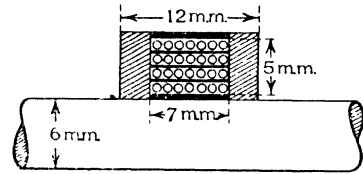

FIG. 103.

in opposition in pairs as follows, viz. :

Coils 1 and 2; 2 and 3; 3 and 4.

Let S , sq. cms. be the area of the specimen under test,

- „ S_1 „ „ „ search coil 1,
- „ S_2 „ „ „ „ „ 2,
- „ S_3 „ „ „ „ „ 3,
- „ S_4 „ „ „ „ „ 4.

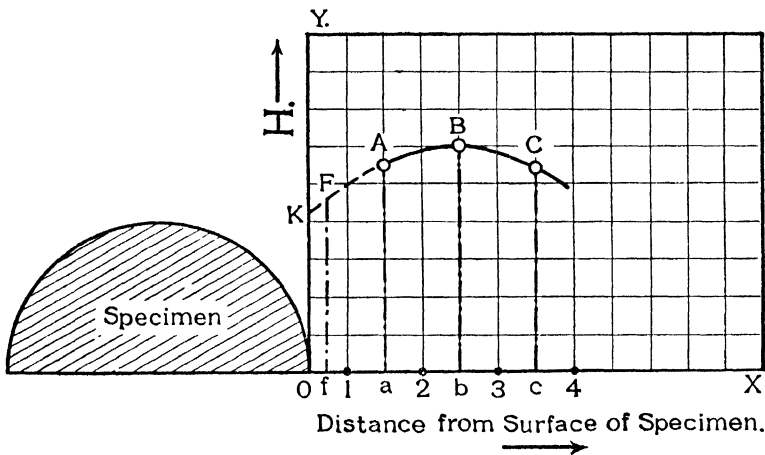

FIG. 104.

Now, referring to Fig. 104, the radial distances from the surface of the specimen are measured along the abscissa axis OX . The distances of the respective search coils from the surface of the specimen are denoted by the numerals 1, 2, 3 and 4.

When the coils 1 and 2 are connected in opposition, suppose the value of the magnetic flux as deduced from the galvanometer throw is denoted by Φ .

Then,

$$H_a = \frac{\Phi}{S_2 - S_1}$$

= Mean value of the magnetic force H in the annular space between the search coils 1 and 2.

The value so obtained is plotted as aA in Fig. 104, where a is the point midway between the points 1 and 2. Similarly, the measurement of the flux by means of the search coils 2 and 3 in opposition gives the value of H_b , plotted as bB in Fig. 104, and the measurement of the flux by means of the search coils 3 and 4 in opposition gives the value of H_c , plotted as cC in Fig. 104.

A curve is now drawn through the three experimental points C, B, A , and the curve is produced to cut the ordinate axis OY at K . Then OK gives the value of H at the surface of the specimen, and this is also the required value of H within the specimen.

(ii) *Measurement of the Induction B.*—

In order to measure the value of B , the innermost search coil (No. 1), is used. It is to be noted however, that for the high values of H which are used in this test the fact that the area S_1 of the search coil 1 is greater than the area S of the specimen necessitates a correction.

For example, if the specimen is 6 mms. in diameter, then

$$S = 28.3 \text{ sq. mms.}$$

If the search coil No. 1 is 7 mms. in diameter, then,

$$S_1 = 38.5 \text{ sq. mms.}$$

therefore,

$$S - S_1 = 10.2 \text{ sq. mms.}$$

Now suppose, for the purposes of an example, that $H = 6,000$ and $B = 26,500$. The total flux through the search coil No. 1 is

$$\begin{aligned} &0.283 \times 26,500 + 0.102 \times 6,000 \\ &7500 + 612 = 8112 \text{ c.g.s. lines.} \end{aligned}$$

The apparent value for B is therefore

$$\frac{8112}{0.283} = 28,600$$

whereas the actual value of B is 26,500.

The necessary correction may therefore be expressed as follows :
Let B' be the apparent value of the induction as deduced from the ratio

$$\frac{\text{Flux through Search Coil No. 1}}{\text{Area of the Specimen}}.$$

Let B be the true value of the flux density in the specimen, then

$$B'S = BS + (S_1 - S)H_f,$$

that is,

$$B = B' - \left(\frac{S_1}{S} - 1\right)H_f,$$

where H_f is the value fF of the force at the point f midway between 0 and 1 (Fig. 104).

Measurements for rectangular specimens may, of course, be made by using rectangular search coils and rectangular holes in the ends of the pole pieces PP .

66. III. Author's Method of Testing Small Specimens in Intense Magnetic Fields

In order to provide an accurate and relatively simple method for testing small specimens in fields of strength up to about 2000 gauss, the author * has devised a modification of the "ring method" described in Chapter X, §§ 55 and 56.

The method has the advantage that the specimen is in the form of a closed magnetic circuit and the value of the magnetising force H can be calculated directly when the magnetising current is known. It is thus possible to carry out the test with considerable accuracy for the whole range of magnetising force from $H = 0$ to about $H = 2000$ gauss.

* See T. F. Wall, *Engineering*, March 7, 1924.

The advantages of testing a sample which is small are numerous. For example, if it is desired to examine the effects of heat treatment on the magnetic properties, it is much more reliable to deal with a small sample, since the heat treatment can thus be made more homogeneous throughout. Further, the cost of the newer types of permanent magnet steels is relatively high, and if large specimens are used for testing, the cost of testing may be seriously increased.

It is to be observed that in the case of the newer types of permanent magnet steels the demagnetising curve, that is to say, the values of the remanence and the coercive force, should be obtained after the magnetisation has been carried up to a value of H about 2000 gauss. If the magnetisation is not carried up to values of this order, the material does not become fully magnetised and the remanence and the coercive force obtained will not be the maximum values which it is possible to reach.

The specimen may be in the form of a short tube of, say, $\frac{3}{4}$ in. length, $\frac{7}{16}$ in. outside diameter, and $\frac{1}{4}$ in. inside diameter.

A search coil is wound on the specimen as close as possible to the material without endangering the insulation of the wire. After winding, the coil should be coated with shellac. Fine wire (*e.g.*, No. 36 s.w.g.) should be used for this search coil, and, as already stated, the winding should be arranged as close to the specimen as possible in order to eliminate the necessity for any correction for B due to the fact that the area of the search coil will not be identical with the area of the specimen (see § 65).

A magnetising coil is wound over the search coil and the number of turns which it is possible to wind for this coil is, of course, limited by the space available inside the tube. This space should not be too tightly packed with the wire of the coils, as it is essential that, when the whole is immersed in an oil-bath, the oil shall have free access to the individual turns of the coil.

The windings of both the search coil and the magnetising coil thread the tube, the sample being magnetised in a circular direction coaxially with the tube.

The relationship between the current in the exciting coil and the magnetising force H is given by the equation

$$\frac{4\pi}{10} Iw = Hl_m$$

where I amperes is the current in the exciting coil,
 w is the number of turns in the exciting coil,
 l_m cms. is the length of the mean magnetic path in the sample.

In order to obtain values of the magnetising force H of the order of 2000 gauss, it will be necessary to send a heavy current through the magnetising coil. For example, suppose the specimen (see Fig. 105) has the dimensions stated, viz. :

Inside diameter	0.25 in.
Outside diameter	0.438 in.

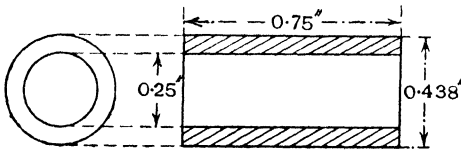

FIG 105.

The mean diameter will be 0.344 in. and the length of the mean magnetic circuit will be
 $l_m = \pi \times 0.344$ in. = 1.08 ins.
 = 2.75 cms.

If the magnetising coil has 30 turns, that is, $w = 30$ in the above formula, then the exciting current necessary to produce a magnetising force of H gauss along the mean magnetic circuit is given by

$$I = 0.073 H \text{ ampere.}$$

Hence, if the magnetising force H is to be equal to 2000 gauss, the current in the exciting coil must be 146 amperes.

The area of the specimen of which the dimensions are given above (see also Fig. 105) will be

$$\begin{aligned} A &= 0.75 \times 0.094 \text{ sq. in.} \\ &= 0.453 \text{ sq. cm.} \end{aligned}$$

The principle of the method is based on the fact that a very large current may be passed through a coil if the time for which

the current flows is sufficiently small (see also Chapter VIII, § 49). That is to say, since the heat developed in a coil is

$$I^2Rt \text{ joules,}$$

where I amperes is the current in the coil,

R ohms is the resistance of the coil,

t seconds is the time for which the current flows,

and if the time t is made sufficiently small, it is possible to pass an extremely large current through the coil without burning it out.

This method of testing is a "method of reversals" as described in Chapter X. A characteristic feature, however, of the present method is that means are provided to permit the opening of the exciting coil circuit immediately after the reversal of the current, and without interfering with the swing of the galvanometer. Thus in the normal method of reversals as described in Chapter X the current in the exciting coil is reversed and the galvanometer throw observed whilst the exciting current is maintained at the full value to which it has been reversed. It would not be possible to open the exciting coil circuit in this case until the galvanometer has completed its swing, otherwise the corresponding collapse of flux through the search coil would, of course, pull up the movement of the galvanometer.

In the present method, the search coil is short-circuited by the key K_1 (Fig. 106) immediately the galvanometer begins to swing and, whilst the search coil is short-circuited, the exciting coil circuit is opened. In this way, the opening of the exciting coil does not impede the swing of the galvanometer and the exciting coil is relieved of the dangerously high currents involved in obtaining the required high intensity of the magnetising force H .

In order to facilitate the cooling of the exciting coil, the specimen is immersed, preferably in a deep oil-bath (see Fig. 106).

The complete diagram of connections for the determination of both the magnetisation curve and the demagnetising curve is given in Fig. 106.

(i) *To Obtain the Magnetisation Curve.*—The short-circuiting

switches Sw_2 and Sw_3 (Fig. 106) are closed and are kept closed throughout this test for the magnetisation curve. The resistance R_1 is set so that the highest value of the current is obtained, that is, the value corresponding to the highest value of the magnetising force H for which the test is to be made.

By means of the reversing switch RS the exciting current is reversed a number of times, care being taken to allow the heat

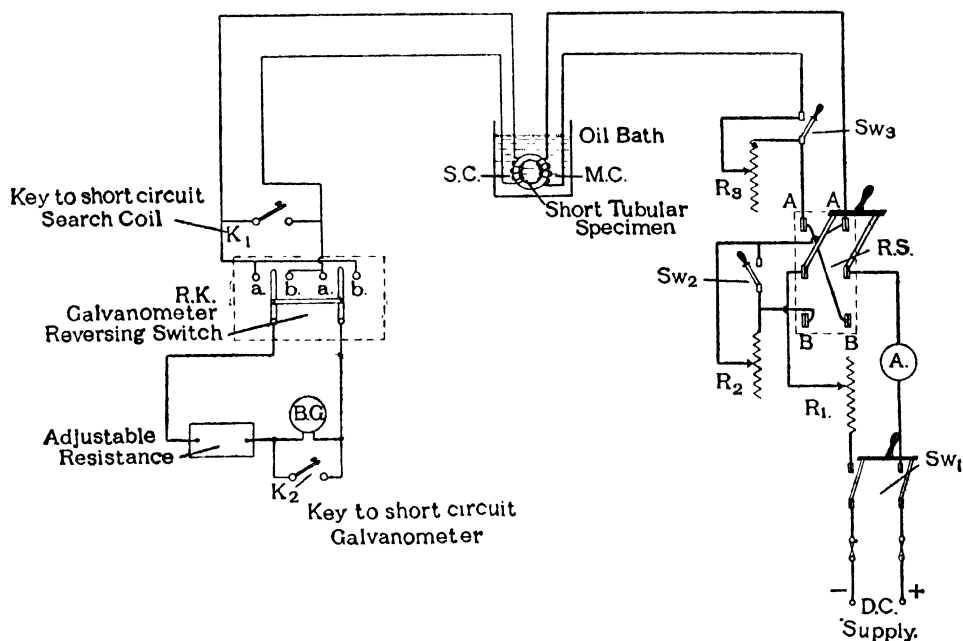

FIG. 106.

developed in the exciting coil to dissipate after each reversal and care also being taken to carry the magnetisation through its changes in precisely the same cyclic order throughout. It is to be noted that, owing to the large values of the exciting current used for this test, the resistance of the circuit may tend to increase appreciably, due to the heating up of the various parts of the circuit. It is desirable, therefore, to use carbon rheostats as series resistances so that the negative resistance coefficient of the carbon may compensate for the positive temperature coefficient of the exciting coil and any other part of the circuit which is of copper, *e.g.*, the leads, etc.

Having made sure that the specimen has been brought into a cyclic magnetic state, and that the galvanometer is steady at its zero position, operate the switches as follows :

(1) Place the galvanometer reversing key RK on the aa contacts : close the search coil short-circuiting key K_1 and close the reversing switch RS on the AA contacts. Open the key K_1 and, after quickly throwing over the reversing switch RS on to the BB contacts, short-circuit the search coil by the key K_1 and open the reversing switch RS .

Read the galvanometer throw θ_1 , which is, say, on the positive side of the scale zero.

(2) Place the galvanometer reversing key RK on the bb contacts. Repeat the procedure detailed in (1). This will give the galvanometer throw θ_2 , which will now be on the negative side of the scale zero.

It is now advisable to take two further readings of the galvanometer deflections for the case in which the main reversing switch RS is reversed from the BB contacts to the AA contacts. This is done as follows :

(3) Place the galvanometer reversing switch on the aa contacts. Close the search coil short-circuiting key K_1 and close the main reversing switch RS on the AA contacts and then open this switch. This brings the magnetic state of the specimen to the point on the cycle which is correct for the next operation of closing the main reversing switch on to the BB contacts. The galvanometer throw is then taken when the main reversing switch RS is thrown over from the BB contacts to the AA contacts.

Let θ_3 be the galvanometer throw so obtained.

(4) Place the galvanometer reversing switch on to the bb contacts and again take the galvanometer deflection when the main reversing switch RS is thrown over from the BB contacts to the AA contacts.

Let θ_4 be the galvanometer deflection in this case.

The mean value of the four deflections θ_1 , θ_2 , θ_3 and θ_4 may then be taken as the correct value of the deflection θ for the given value of the magnetising current.

Of course, there should be no serious difference between the four readings of any one set.

If λ is the logarithmic decrement of the galvanometer swing for the known value of the total resistance of the galvanometer circuit, the value of the deflection as corrected for damping will be (see Chapter IX, § 52) :

$$\theta = \theta \left(1 + \frac{\lambda}{2} \right).$$

ii. *To Obtain the Demagnetisation Curve and the Hysteresis Loop.*— For this test the switches Sw_2 and Sw_3 are brought into operation. For that part of the demagnetisation curve which extends from $H = H_{\max.}$ to $H = 0$ (e.g., the part AL in Fig. 94), the switch Sw_2 is kept closed and the switches RS and Sw_3 are operated, whilst for that part of the demagnetisation curve which corresponds to negative values of H (e.g., the part LM in Fig. 94), the switch Sw_3 is kept closed and the switches RS and Sw_2 are operated.

First set the resistance R_1 with the switches Sw_2 and Sw_3 closed so that the requisite exciting current flows in the magnetising coil MC to produce the required value of $H_{\max.}$ for the tip A of the hysteresis loop (see Fig. 94). Find by trial the adjustment of the resistance R_3 , so that, when the switch Sw_3 is open (and the reversing switch RS on the AA contacts), the magnetising current will have a value corresponding to some suitable value of H to give some such point as D (Fig. 94) on the demagnetisation curve. Close the switch Sw_3 and reverse the switch RS several times, finishing this operation with the reversing switch open after having left the BB contacts. Then proceed as follows :

Close the key K_1 , thus short-circuiting the search coil SC . With the galvanometer reversing switch on the aa contacts, close the reversing switch RS on the AA contacts, open K_1 , open Sw_3 , close the key K_1 and open the reversing switch RS ,

performing this sequence of operations in rapid succession. Note the galvanometer throw.

Other points, such as G on the part AL of the demagnetisation curve, may be obtained in a similar manner, it being observed that, after having made all the adjustments, it is necessary to reverse the switch RS several times before taking a reading of the galvanometer throw. After having reversed the switch RS several times, this switch is eventually left open after leaving the BB contacts. Another reading of the galvanometer throw for the same point on the demagnetisation curve may be obtained by repeating the above process but with the galvanometer reversing switch on the bb contacts.

In order to determine that part of the demagnetisation curve which corresponds to negative value of the magnetising force H , for example, the part LM in Fig. 94, the following procedure is adopted.

The switch Sw_3 is kept closed throughout this test. Having adjusted the resistance R_2 so that the magnetising current in the coil MC has a suitable negative value when the reversing switch RS is on the BB contacts and the switch Sw_2 is open, the galvanometer throw is observed when the reversing switch RS is thrown over from the AA contacts to the BB contacts with the switch Sw_2 open. It will be seen that in this way the magnetising force is changed from the value $+H_{max.}$ to some negative value less than $-H_{max.}$

Before taking any reading of the galvanometer throw, the switch Sw_2 is closed and the reversing switch RS is operated several times eventually finishing with this switch open after leaving the BE contacts. The switch Sw_2 is then opened and the required galvanometer throw is taken by means of the following process :

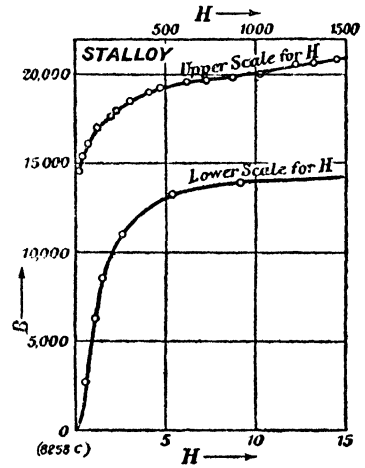

FIG. 107.

Close the key K_1 , thus short-circuiting the search coil SC . With the galvanometer reversing switch RK on the aa contacts, close the reversing switch RS on the AA contacts, open K_1 , throw over the reversing switch RS on to the BB contacts, close

the key K_1 , and open the reversing switch, performing this sequence of operations in rapid succession. Note the consequent throw of the galvanometer.

In all cases a second reading for any one point on the demagnetisation curve may be obtained by repeating the process described but with the galvanometer reversing switch RK on the bb contacts.

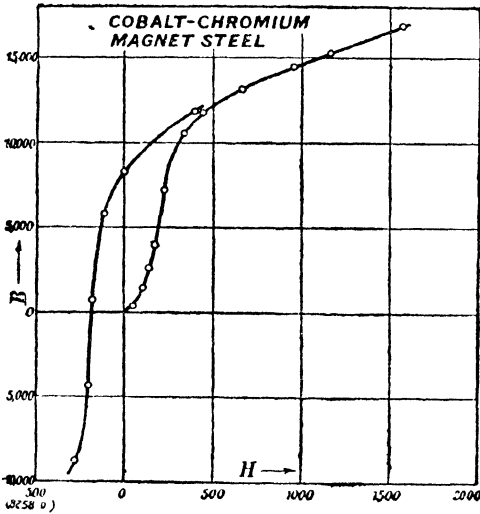

FIG. 108.

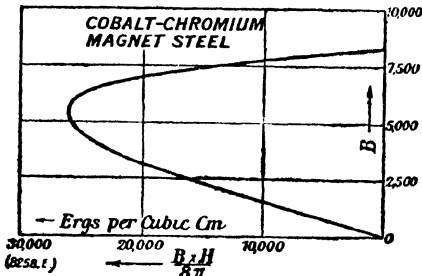

FIG. 109.

In Fig. 107 is shown the magnetisation of a sample of "stalloy" as taken by this method.

In Fig. 108 is given the magnetisation curve and also the demagnetisation curve as determined by this method, of a sample of cobalt-chromium steel. In Fig. 109 are shown the values of the quantity $\frac{B \times H}{8\pi}$ for this sample of

steel, the data for Fig. 109 having been obtained from the experimental demagnetisation curve of Fig. 108 (see also Chapter II, § 22, and Fig. 22).

CHAPTER XIII

DETERMINATION OF THE MAGNETISATION CURVE AND THE HYSTERESIS LOOP BY THE MAGNETOMETER METHOD

67. General Features of the Magnetometer Method

THE magnetometer method is one of the oldest methods of magnetic testing and is especially valuable for some tests for which the ballistic method is not suitable. For instance, the magnetometer test gives the actual *static* value for the magnetic intensity J directly without any necessity for measuring the *change* of J , as, for example, by reversal of the exciting current.

The method is also useful for measuring the effect on the magnetisation of mechanical strain; moreover, it provides a means for examining the changes in magnetisation due to time, *e.g.*, the testing of the decay of magnetisation in permanent magnets, and the "creeping effect" referred to in Chapter IV, § 35, when the magnetising force is relatively small and is maintained constant.

The principle of the method is the measurement of the deflection of a small magnetised needle under the influence of the magnetisation of the specimen under test.

It is to be noted that the magnetic quantity which is actually measured here is the *intensity of magnetisation* J , from which the corresponding value of the induction B is obtained through the relationship

$$B = 4\pi J + H.$$

For the purposes of magnetometer tests, a very suitable form for the specimen would be a long ellipsoid of revolution. Such a form, however, would be rather difficult to machine and usually a long circular rod of the material is used as being a sufficiently good approximation to an ellipsoid of revolution. The advantage of using a specimen in the form of an ellipsoid of revolution is the fact that the self-demagnetising force is then constant throughout the specimen and its value can be easily calculated (Chapter I, see § 10).

There are three methods of arranging the rod specimen relatively to the magnetometer needles, and these will be considered in turn.

68. Magnetometer Method I. The "One Pole" Method

In this case the rod under test is arranged vertically with the upper pole on a level with the magnetometer needle.

In Fig. 110 is shown a diagrammatical sketch of the relative position of the rod CC' and the magnetometer needle, the centre of which is indicated by the point O .

The poles of the magnetised rod CC' are at the points PP' and the upper pole P is level with the compass needle O .

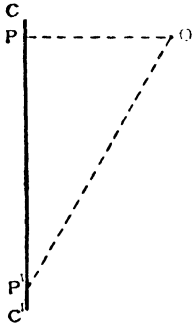

FIG. 110.

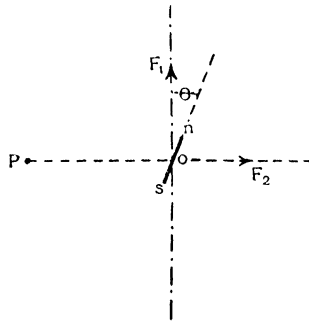

FIG. 111.

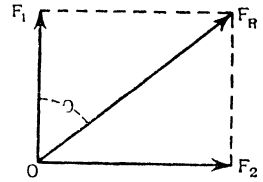

FIG. 112.

In Fig. 111 is shown a plan view, in which P represents the pole of the magnetised specimen and O is the centre of the magnetometer needle ns .

When the magnetised specimen is removed, the direction of the needle ns will, of course, be that of the horizontal component of the Earth's field.

Let F_1 be the intensity of the horizontal component of the Earth's field. In what follows, F_1 will be called the *directing force*.

Suppose that the upper pole P (Fig. 111) is a North-seeking pole. The forces on the needle ns will then be

$$F_2 \text{ due to the pole } P$$

and

$$F_1 \text{ due to the Earth's directing force.}$$

It is here assumed that the rod specimen is so long that the effect of the distant pole P' on the deflection of the needle ns is negligibly small. The effect of the distant pole P' will be considered later.

The resultant force at O will then be given in magnitude and direction by F_R , Fig. 112, and the needle ns will therefore take up a position in line with F_R . That is to say, the deflection of the magnetometer needle will be θ .

Reference to Fig. 112 shows that

$$F_2 = F_1 \tan \theta.$$

But

$$F_2 = \frac{\pi a^2 J}{OP^2}$$

where J is the intensity of magnetisation of the specimen and πa^2 sq. cms. is the cross-sectional area of the specimen, which is here assumed to be circular (see also Chapter I, §§ 1 and 6).

Therefore

$$\frac{\pi a^2 J}{OP^2} = F_1 \tan \theta,$$

or,

$$J = \frac{OP^2 F_1}{\pi a^2} \tan \theta$$

Usually, the magnetometer deflection θ will be small, so that $\tan \theta = \theta$ very approximately, in which case

$$J = \frac{OP^2 F_1 \theta}{\pi a^2}$$

As already stated, the formula given in the foregoing assumes that the specimen is so long that the effect of the distant pole P' on the deflection of the needle is negligibly small.

If this is not the case, it is easy to show that

$$J = \frac{OP^2 F_1 \tan \theta}{\pi a^2 \left[1 - \left(\frac{OP}{OP'} \right)^3 \right]}$$

The arrangement of apparatus necessary for this test is shown

in Fig. 114. The specimen is supported within a solenoid S_1S_1 which extends well beyond the ends of the specimen (see Fig. 113). In order to neutralise the magnetic effect on the magnetometer needle of the current in the solenoid itself, a compensating coil CS is provided which is connected in series with the solenoid. The position of the compensating coil is so adjusted that when the specimen is removed from the solenoid, and the current is reversed in the solenoid circuit, the magnetometer needle remains undeflected. If the specimen is now inserted in the solenoid, the action on the magnetometer needle will be solely due to the magnetic intensity J .

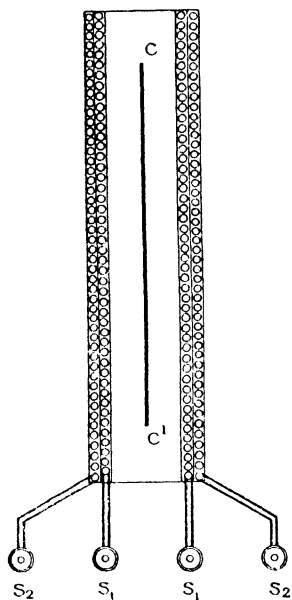

FIG. 113.

It is to be noted that, since the specimen is supported vertically, it is subject to magnetisation by the vertical component of the Earth's field and it may be necessary to provide means for neutralising the vertical component of the Earth's field. Whether this is necessary in any particular test depends on the accuracy with which the test is required at low values of the magnetising force H . The neutralisation of the vertical component of the Earth's field may be obtained by winding a second solenoid S_2S_2 (Fig. 113) co-axially with the magnetising solenoid and

sending a current through this second solenoid from a separate circuit so that the field produced by this second solenoid may be just sufficient to neutralise the vertical component of the Earth's field.

Before commencing the test on the specimen, it is necessary that it be completely demagnetised, and one way of doing this is by the method of reversals.

In Fig. 114 is shown the diagram of connections. The magnetising solenoid S_1 is connected through a reversing switch RS and an ammeter Am_2 to the potential slide PS .

The switch Sw_1 is preferably kept closed except when readings for the hysteresis loop are required to be taken.

By means of the potential slide PS and the resistance R_1 the current in the magnetising solenoid can be varied from zero to the full maximum value which it is required to obtain.

The compensating coil CS is in series with the magnetising solenoid S_1 , so that the compensation remains correct for all values of the magnetising current.

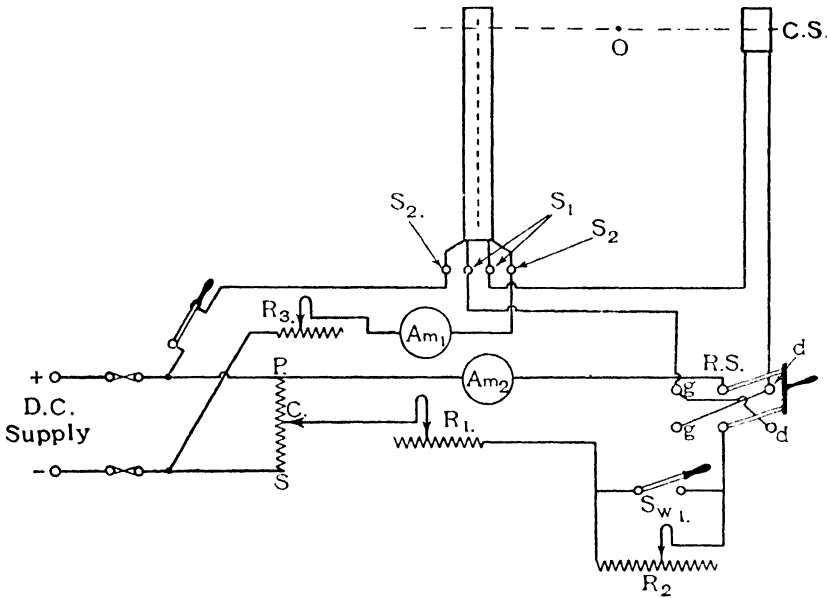

FIG. 114.

The vertical component of the Earth's field is neutralised by the compensating solenoid S_2 , which is supplied with current through the ammeter Am_1 .

The test as to whether the vertical component of the Earth's field has been correctly neutralised is that, after passing through the complete demagnetising process, the specimen should show no remanent magnetism, that is, the magnetometer needle should be undeflected when there is no current flowing in the magnetising solenoid S_1 .

In order to demagnetise the specimen before proceeding with the test, the current in the magnetising solenoid S_1 is set to the maximum value which can be safely passed through the solenoid and the reversing switch RS is operated so that the current is reversed at the rate of, say, about 1 cycle per second. Whilst steadily operating the reversing switch, the potential slide contact C is gradually moved towards P , until eventually C reaches P and the current in the magnetising solenoid therefore becomes zero. At the end of this process the specimen should then have become completely demagnetised.

If the area of the specimen is large, it may be found that the control F_1 due to the horizontal component of the Earth's field is not sufficiently strong. In this case, the control may be strengthened by placing a bar magnet under the needle. The magnitude of this increased control can be measured by the methods explained in § 71 for finding the value of F_1 .

Determination of the Magnetisation (B : H) Curve.—For the magnetisation curve, the switch Sw_1 (Fig. 114) is kept closed. Having adjusted the position of the contact C and the magnitude of the resistance R_1 to give a small value of the magnetising current the reversing switch RS is placed on the dd contacts and the corresponding deflection θ of the magnetometer needle is noted. By means of the formula given in § 53, the value of the magnetising force H is found, viz. :

$$H = \frac{4\pi}{10} \frac{w_1}{l} I \text{ gauss,}$$

where w_1 is the total number of turns in the magnetising solenoid S_1 ,

l cms. is the length of the magnetising solenoid S_1 ,

I amperes is the current in the magnetising solenoid.

If the length of the specimen is less than about 400 times the diameter, it may be necessary to correct for the self-demagnetising effect of the specimen. This may be done by means of the data given in Chapter I, § 10.

The value of the intensity of magnetisation J is given by the formula

$$J = \frac{OP^2 F_1 \tan \theta}{\pi a^2 \left[1 - \left(\frac{OP}{OP'} \right)^3 \right]}$$

The magnitude of the induction B is then given by

$$B = 4\pi J + H.$$

The value of the directing force F_1 of the magnetometer is found by one of the methods explained in § 71.

A series of values of the magnetising current is then taken and the corresponding values of the deflections θ are measured.

In this way the complete magnetisation curve of the specimen may be found up to an intensity of the magnetising force H of about 500 to 600 gauss. The method is not suitable for tests at higher values of the magnetising force.

In making the adjustments of the magnetising current it is important to observe that the current is never reduced during the test, but that each change in value shall be an increase and not a decrease. If the magnetising current is accidentally decreased, the specimen should be first completely demagnetised and the test commenced again.

Determination of the Hysteresis Loop.

(i) *To Obtain the Portion of the Hysteresis Loop mn, Fig. 91.*— Having completely demagnetised the specimen, the reversing switch RS is placed on the dd contacts and the magnetising current set to give the full value of the induction B_{\max} for which the required hysteresis loop is to be found. That is to say, the magnetising current is set to the value corresponding to the tip m of the hysteresis loop (Fig. 91). The iron specimen is then brought into a cyclic magnetic state by reversing RS a number of times, eventually finishing up with RS on the dd contacts. The switch Sw_1 is kept closed during this operation. The resistance R_2 is then set to a suitable value, so that when the switch Sw_1 is opened, the magnetising current will correspond to some value, say, CP (Fig. 91).

The setting of the resistance R_2 may be found by a preliminary trial before the actual test is commenced. The deflection of the magnetometer needle is then noted for this reduced value of the magnetising current, and this deflection will correspond to some such point as P on the hysteresis loop. By suitably increasing the resistance R_2 , other points may be found on this portion of the hysteresis loop and in this way the whole of the portion mn (Fig. 91) may be obtained. The point n , which corresponds to zero current in the magnetising solenoid, is obtained by opening the reversing switch RS .

(ii) *To Obtain the Portion nl of the Hysteresis Loop, Fig. 91.*—Having completed the portion mn of the loop, the reversing switch RS is now in the “off” position, that is, no current is flowing in the magnetising solenoid S_1 .

The switch RS is now closed on the gg contacts, the magnetising current corresponding to a suitable negative value, say, dQ (Fig. 91) being thus obtained.

By decreasing the resistance R_2 the magnitude of the negative magnetising current is increased and another point on the loop, say, T , is obtained. In this way, the whole portion of the loop is determined, the last point l being obtained for a value of the negative magnetising current which is just equal to the maximum positive value of the current for which the point m was found.

(iii) *To Obtain the Portion $ln'm$ of the Hysteresis Loop, Fig. 91.*—The other half $ln'm$ of the hysteresis loop may be found by reversing the above detailed procedure. For points on the portion ln' the magnetometer deflection is obtained when the reversing switch RS is on the gg contacts and for points on the portion $n'm$ of the hysteresis loop the switch RS is closed on the dd contacts.

If, at any stage of the test, there is reason to think that the current has been changed in the wrong direction, say, for example, the current has been reduced instead of increased, the magnetisation should be brought back to the required cyclic state by operating the switch RS with the switch Sw_1 closed.

69. Magnetometer Method II. The Specimen is Placed "Broad-side On" with Respect to the Magnetometer Needle

The general arrangement of the specimen and magnetometer needle is shown in Fig. 115. The specimen is placed horizontally and at right angles to the directing force.

In this case, it is easy to prove that the force F_2 due to the magnetisation of the specimen is

$$F_2 = \frac{2\pi a^2 J P B}{O P^2 d}$$

in which πa^2 is the cross-sectional area of the specimen.

Hence

$$F_1 \tan \theta = \frac{2\pi a^2 J P B}{O P^2 d}$$

or the intensity of magnetisation is

$$\begin{aligned} J &= \frac{O P^2 d}{2\pi a^2 P B} F_1 \tan \theta \\ &= \frac{O P^2 d}{\pi a^2 P P_1} F_1 \tan \theta. \end{aligned}$$

Putting

$$d = O P^2,$$

gives

$$J = \frac{O P^3}{\pi a^2 P P_1} F_1 \tan \theta.$$

For an ellipsoid of length l

$$P P_1 = \frac{2}{3} l$$

and

$$J = \frac{3 O P^3}{2 \pi a^2 l} F_1 \tan \theta.$$

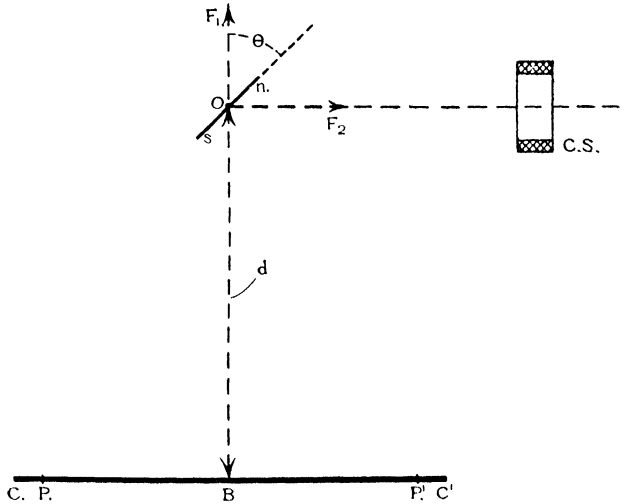

70. Magnetometer Method III. The Specimen is Placed "End On" with Respect to the Magnetometer Needle

In Fig. 116 is shown the relative positions of the specimen and the magnetometer needle for this method. The specimen is placed horizontally and with its length at right angles to the directing force; the centre of the needle lies on the prolongation of the axis of the specimen.

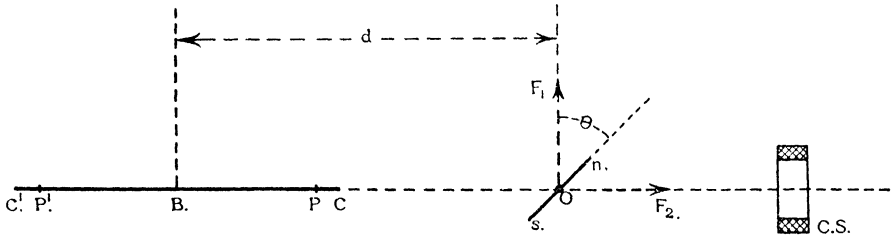

FIG. 116.

The force at the centre O of the needle and due to the magnetisation of the specimen is

$$F_2 = \frac{J\pi a^2}{\left(d - \frac{l}{2}\right)^2} - \frac{J\pi a^2}{\left(d + \frac{l}{2}\right)^2}$$

or

$$F_2 = 2J\pi a^2 \frac{al}{\left(d^2 - \frac{l^2}{4}\right)^2}$$

It follows therefore from Fig. 116 that

$$F_1 \tan \theta = F_2$$

and

$$J = \frac{\left(d^2 - \frac{l^2}{4}\right)^2}{2\pi a^3 l} F_1 \tan \theta.$$

where $l = PP'$.

71. Calibration of the Magnetometer

It is desirable to calibrate the magnetometer directly *in situ* in order to determine the magnitude of the directing force in th

position occupied by the magnetometer needle. It is not advisable to take this as being equal to the horizontal component of the Earth's field at that place, because there may be large masses of iron in the neighbourhood which may produce a considerable effect on the Earth's field there.

CASE I.—The determination of the magnitude of the directing force may be made by using a circular coil of a single turn as shown by yy' in Fig. 117. The magnetometer needle is situated at the centre of the coil and the plane of the coil contains the axis of the needle when no current is flowing in the coil. That is to say, the plane of the coil is parallel to the directing force F_1 .

If a current of I amperes is passed through the coil the needle will become deflected. The force F_c due to the current in the coil will be in a direction perpendicular to the directing force F_1 and the magnitude of the deflecting force will be given by the expression (see Fig. 117),

$$F_c = \frac{2\pi I}{a10}$$

where a cms. is the radius of the coil.

The needle will therefore be deflected by an angle θ , where

$$F_1 \tan \theta = F_c = \frac{2\pi I}{a10}$$

or

$$F_1 = \frac{\pi I}{5a \tan \theta} = \frac{0.63I}{a \tan \theta}.$$

CASE II.—The measurement of the magnetometer directive force F_1 may be made by means of a suspended oscillating magnet.

Suppose a short piece of magnetised hard steel wire is obtained and is suspended horizontally by means of a light stirrup hanging from an unspun fibre of silk. In the place where the magnetometer is to be set up, bring the suspended magnetised wire and let it

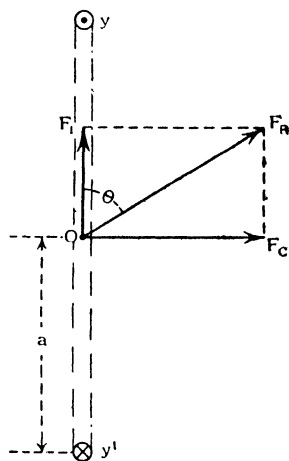

FIG. 117.

oscillate under the action of the directive force F_1 . Note the time required for, say, 20 complete oscillations, and let T_1 seconds be the average time of one complete oscillation.

Now remove the suspended magnet to some open space where the horizontal component F of the Earth's field is accurately

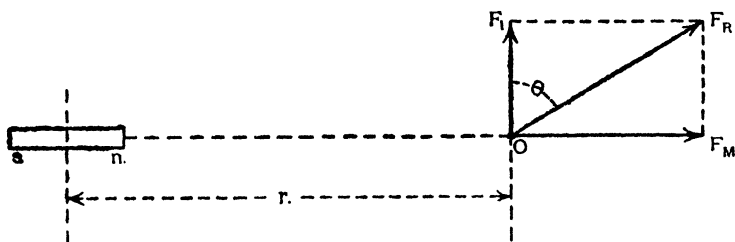

FIG. 118.

known and set it oscillating again. Let T seconds be the time of one complete oscillation under the action of this force F .

Then it may be shown that

$$F_1 = F \frac{T^2}{T_1^2}$$

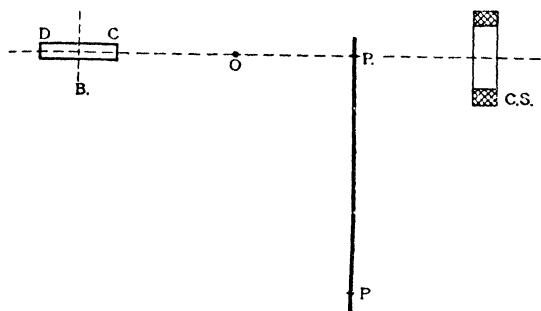

FIG. 119.

72. Use of a Compensating Magnet

A compensating magnet may be used if it is desired to extend the equivalent scale length. For instance, in Fig. 119, the deflecting magnet may be arranged with its axis on the line OP

and so directed that it opposes the deflecting action of the magnetisation of the specimen. Thus, if P is a N pole, the end C of the magnet would be a S pole. In other words, the compensating magnet subtracts a definite amount from the deflecting force of P at the needle.

Let F_M be the deflecting force at the needle due to the com-

compensating magnet, and let F_2 be the deflecting force due to the magnetisation of the specimen. Then

$$F_2 - F_M = F_1 \tan \theta = F_1 \theta, \text{ when } \theta \text{ is small.}$$

The true deflection due to the magnetisation J of the specimen will therefore be the actual deflection plus the amount by which the deflection is reduced when the compensating magnet is placed in position.

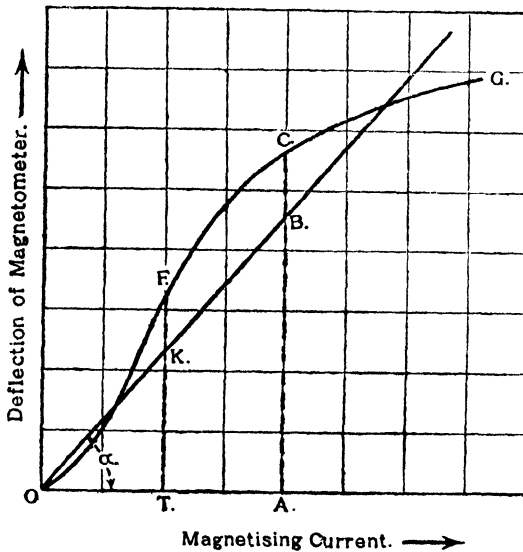

FIG. 120.

A special advantage of using the compensating magnet is that it permits of the examination of the effect of a small increase or decrease of the magnetising force when the specimen is strongly magnetised.

73. Increasing the Sensitivity of the Magnetometer by Over-compensation

If the compensating coil (see § 68, Fig. 114), is moved nearer to the magnetometer needle than is necessary for just compensating the magnetic force of the solenoid, it is possible to increase the sensitivity of the magnetometer very considerably.*

* See Ewing, "Magnetic Induction in Iron and Other Metals."

For example, suppose it is desired to examine the shape of the magnetisation curve OFG (Fig. 120) for values near the origin O , that is, for weak magnetising forces.

The specimen is arranged closer to the magnetometer needle than is normally the case, thus increasing the deflecting force due to the magnetisation of the specimen. This deflecting force is then partly neutralised by moving the compensating coil up towards the needle. Thus, in Fig. 120, if the magnetising force is OA the true deflection would be AC . Suppose, however, that the compensating coil has been fixed in position near the needle so that the amount AB of the deflection becomes neutralised thereby, the actual deflection being BC . Join B to the origin O and let α be the angle AOB . If the magnetising current is now altered, say to the value OT , the actual deflection will be KF . To obtain the true deflection, however, the amount TK must be added to the actual deflection KF . That is to say,

True Deflection = Actual Deflection + (Magnetising Current) $\tan \alpha$.

The value of $\tan \alpha$, that is, the slope of the line OB , is found by removing the specimen from the solenoid and noting the deflection of the magnetometer needle when a known current is flowing in the compensating coil and the solenoid in series.

By means of this device, therefore, the whole length of the scale may be utilised for the deflection corresponding to the amount, say CB . In other words, the effective scale length may be enormously increased whilst still keeping the actual deflection small.

In this way, the magnetic testing of ellipsoidal specimens may be carried out when the ratio of the length to the diameter is small, that is, when the self-demagnetising force is large.

CHAPTER XIV

TOTAL LOSSES IN IRON LAMINATIONS: MEASUREMENT BY MEANS OF THE MAGNETIC SQUARE: SEPARATION OF THE LOSSES

74. Total Losses in Iron Laminations

WHEN iron laminations are subjected to an alternating magnetic flux, in addition to the hysteresis loss there is a loss due to eddy currents which are induced in the laminations by the alternating flux.

It may be shown that for low frequencies, *e.g.*, about 50 cycles per second, and thin iron plates, say about 0.5 mm., the loss due to eddy currents is proportional to the square of the thickness of the laminations. If the thickness of the laminations is greater than about 0.5 mm. or if the frequency is greater than about 50 cycles per second, the phenomenon of "skin effect" may become prominent. That is to say, the central part of the section of the laminations may become largely screened from the magnetic flux by reason of the induced eddy currents. When this effect becomes marked the formulæ given in the following do not apply directly.

The total iron losses due to an alternating magnetic flux comprise hysteresis loss and eddy current loss.

The hysteresis loss may be represented by the formula (see Chapter I, § 15),

$$W_h = \eta f B_{\max}^{1.6} \text{ ergs per sec. per c.c.}$$

This expression may be taken as holding true for a range of values of B_{\max} from about 1000 to 13,000 lines per sq. cm. (see also § 78).

The eddy current loss is given by the expression

$$W_e = \epsilon (f_x f B_{\max} \Delta)^2 \text{ ergs per sec. per c.c.,}$$

where B_{\max} is the maximum value of the flux density during the cycle,

f_x is the form factor of the alternating wave of magnetic flux,

f cycles per second is the frequency of the alternating flux,

Δ cms. is the thickness of the laminations,

ϵ is "eddy current constant" and depends on the specific electrical resistance of the material of the laminations,

η is the "hysteresis constant."

The total iron losses may therefore be written

$$W_i = W_h + W_e = [\eta f B_{\max.}^{1.6} + \epsilon (f_x f B_{\max.} \Delta)^2] \text{ ergs per sec. per c.c.}$$

or, since 10^7 ergs = 1 joule, and 58.5 c.c. of iron weigh 1 lb., the total losses may be expressed by the formula

$$W_i = 58.5 \times 10^{-7} [\eta f B_{\max.}^{1.6} + \epsilon (f_x f B_{\max.} \Delta)^2] \text{ watts per lb.}$$

75. The Magnetic Square

The magnetic square is an apparatus for measuring the total losses in iron laminations due to an alternating magnetic flux. There are several types of construction in use, which differ to some extent in detail. A common arrangement is the one shown in outline in

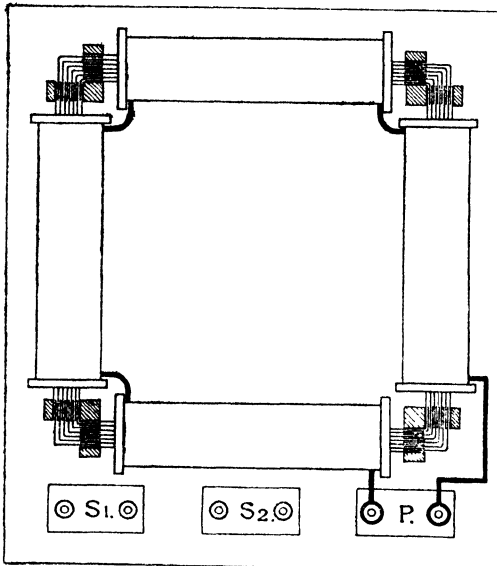

FIG. 121.

Fig. 121. Four equal solenoids are arranged in the form of a square. Equal bundles of iron laminations are inserted, one in each solenoid, each lamination being about 7 cms. wide and usually about 0.05 cm. thick. The ends of the bundles are magnetically connected by short lengths of laminations bent at right angles and forming lap joints having about 2 or 3 mms. overlap at each joint as shown in Fig. 121.

Each solenoid comprises one winding of thick wire which carries the magnetising current, the four solenoid windings being connected in series. This winding will be termed the primary winding and, for the particular example under consideration, consists of 45 turns per solenoid, that is, a total of 180 turns between the terminals P in Fig. 121.

Each solenoid also comprises two separate thin wire windings. These windings form two electrically separate secondary coils. The windings for the respective secondaries on the individual solenoids are connected in series and the terminals for one secondary are shown at S_1 and for the other secondary at S_2 in Fig. 121. In the example under consideration, both S_1 and

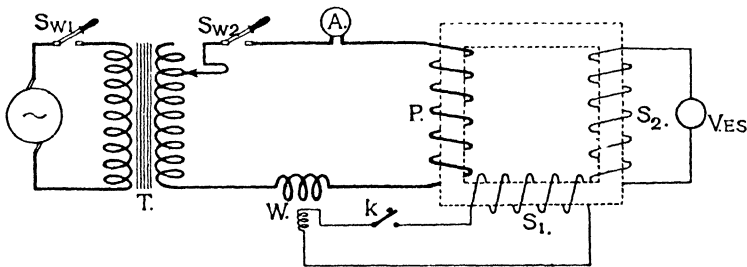

FIG. 122.

S_2 are wound with 74 turns per solenoid, that is, there is a total of 296 turns in each of the search coils S_1 and S_2 .

A diagram of connections is shown in Fig. 122. The wattmeter is shown at W , the current coil being in series with the primary winding P of the magnetic square, whilst the pressure coil is connected across the secondary S_1 . An ammeter is shown at A , and a transformer at T . The transformer has a variable secondary so that the current in the primary winding P of the magnetic square may be varied without the use of series resistance, that is, without altering the form factor of the flux wave (see also § 76). An electrostatic voltmeter V_{ES} is connected across the terminals of the secondary S_2 .

Let E volts be the r.m.s. value of the p.d. indicated by the voltmeter V_{ES} , then

$$E = 4f_x f B_{\max} A_i w_{s2} 10^{-8} \text{ volts,}$$

where f_x is the form factor of the alternating wave of magnetic flux,

f is the frequency of the alternating wave,

B_{\max} is the maximum value of the magnetic induction in the laminations during a cycle,

A_i sq. cms. is the cross-sectional area of the iron laminations,

w_{s2} is the number of turns in the secondary winding S_2 .

Let W watts be the power measured by the wattmeter. The total power actually supplied to the apparatus, exclusive of the heat loss in the primary winding P , will be

$$W \frac{E}{V} \text{ watts,}$$

where V volts is the p.d. across the pressure coil of the wattmeter. That is to say, the total power supplied will be greater than W by an amount due to the loss in the secondary S_1 .

Now,

$$W \frac{E}{V} = W \frac{r_{s1} + r_w}{r_w}$$

where r_{s1} ohms is the resistance of the secondary S_1 ,

and r_w ,, ,, ,, pressure coil of the wattmeter.

The total iron loss will then be

$$\begin{aligned} W_i &= W \frac{E}{V} - [\text{loss in } r_{s1} + \text{loss in } r_w] \\ &= W \frac{r_{s1} + r_w}{r_w} - [i^2 r_{s1} + i^2 r_w], \end{aligned}$$

where i amperes is the r.m.s. value of the current in the pressure coil circuit of the wattmeter.

Hence

$$W_i = W \left[\frac{r_{s1} + r_w}{r_w} \right] - E^2 \left[\frac{1}{r_{s1} + r_w} \right]$$

If the test is made at high values of B_{\max} , say greater than about 12,000 lines per sq. cm., allowance must be made for the fact that the iron laminations occupy a portion only of the core of the solenoid. For high values of B_{\max} the flux in that part of the cross-section of the secondary coils which is not occupied by the iron laminations becomes appreciable. That is to say, if this part of the flux is neglected in the calculations, the result will be that the value of B_{\max} as deduced from the voltage E will be too large.

The necessary allowance may be made as follows :

The induced e.m.f. E may be written

$$E = 4f_xfw_{s_2}\phi_{\max}. 10^{-8} \text{ volts,}$$

where ϕ_{\max} is the maximum value during a cycle of the flux which passes through the search coil S_2 .

Now let B'_{\max} be the ideal value of the maximum flux density in the laminations, that is, the value which would be obtained from the formula for the induced e.m.f. E if the whole of the flux were actually to pass through the iron laminations, and let B_{\max} be the actual maximum value of the flux density in the iron laminations, then

$$\phi_{\max} = B'_{\max}. A_i = B_{\max}. A_i + H_{\max}. (\text{Area of } S_2 - A_i)$$

that is,

$$B_{\max} = B'_{\max} - H_{\max}. \left(\frac{\text{Area of } S_2 - A_i}{A_i} \right)$$

The value of H_{\max} for a given value of B_{\max} may be found from the measured value of the permeability of the sample.

If the magnetic square is provided with only one secondary coil, both the pressure coil of the wattmeter and the voltmeter will be connected across the terminals of this secondary as shown in Fig. 123.

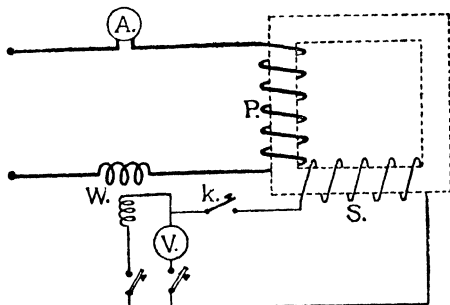

FIG. 123.

Let r_v ohms be the resistance of the voltmeter,
 r_w " " " " pressure coil of the watt-
 meter,
 r ohms be the resistance of the secondary coil S ,
 V volts be the p.d. measured by the voltmeter,
 E volts be the e.m.f. induced in the secondary coil S ,
 i_w amperes be the current in the wattmeter pressure coil,
 i_v " " " " voltmeter,
 W watts be the power measured by the wattmeter,
 W_i watts be the total iron losses.

Then

$$\begin{aligned} E &= V + (i_w + i_v)r_s \\ &= V + \left(\frac{V}{r_w} + \frac{V}{r_v}\right)r_s \end{aligned}$$

if both the voltmeter switch and the pressure coil switch of the wattmeter are pressed together. If, however, the wattmeter pressure coil switch is open when the voltmeter is being read, the term $\frac{V}{r_w}$ in the above expression is zero.

The power actually supplied to the magnetic square, exclusive of the loss in the primary coil P , Fig. 123, will be

$$W \frac{E}{V} = W \left(1 + \frac{r_s}{r_v} + \frac{r_s}{r_w}\right)$$

The total iron losses will then be

$$W_i = W \left(1 + \frac{r_s}{r_v} + \frac{r_s}{r_w}\right) - [i_w^2 r_w + i_v^2 r_v + (i_w + i_v)^2 r_s]$$

that is,

$$W_i = W \left(1 + \frac{r_s}{r_v} + \frac{r_s}{r_w}\right) - V^2 \left(1 + \frac{r_s}{r_v} + \frac{r_s}{r_w}\right) \left(\frac{1}{r_v} + \frac{1}{r_w}\right)$$

or,

$$W_i = \left[W - V^2 \left(\frac{1}{r_v} + \frac{1}{r_w}\right) \right] \left[1 + \frac{r_s}{r_v} + \frac{r_s}{r_w} \right]$$

76. Separation of the Hysteresis and Eddy Current Losses in Iron Laminations

It has been stated in § 74 that the total losses in iron laminations due to an alternating magnetic flux are given by the expression

$$\begin{aligned} W_i &= \eta f B_{\max.}^{1.6} + \varepsilon (f_x f B_{\max.} \Delta)^2 \text{ ergs per sec. per c.c.,} \\ &= 58.5 [\eta f B_{\max.}^{1.6} + \varepsilon (f_x f B_{\max.} \Delta)^2] 10^{-7} \text{ watts per lb.} \end{aligned}$$

The magnitude of the total losses may be measured by means of the magnetic square as described in § 75.

The separation of the total iron losses into those due to hysteresis and eddy currents, respectively, may be carried out by either of two methods. The first method may be used when an alternating current source of variable frequency and constant form factor is available, the second method may be used when an alternating current source of constant frequency is available.

METHOD I.—Separation of Iron Losses by Measurements with a series of Different Frequencies.

This method of carrying out the separation depends upon the condition that the form factor f_x shall be maintained constant as the values of the e.m.f. E and the frequency f are varied. The variation of the e.m.f. E which is necessary to maintain the value of $B_{\max.}$ constant as the frequency is varied should be obtained either by varying the excitation of the alternator or by means of a variable tapping on the secondary of a transformer. A series resistance in the circuit of the magnetising coil of the magnetic square (*i.e.*, coil P , Figs. 122 and 123) should not be used for the purpose of varying E , otherwise the form factor will not remain constant (see Method II).

The value of the total iron loss watts W_i is measured for a number of different frequencies, the magnitude of $B_{\max.}$ being kept the same for each value of the frequency. That is to say, since

$$E = 4f_x f B_{\max.} w 10^{-8} \text{ volts,}$$

therefore

$$B_{\max.} = \text{constant} \frac{E}{f}$$

It is therefore seen that the value of $B_{\max.}$ will remain constant if the induced e.m.f. E is varied proportionally with the frequency f .

If the expression for the total iron losses be divided by the frequency f , the equation becomes

$$\frac{W_i}{f} = 58.5 \times 10^{-7} [\eta B_{\max.}^{1.6} + \epsilon f (f_x B_{\max.} \Delta)^2] \text{ joules per lb. per cycle.}$$

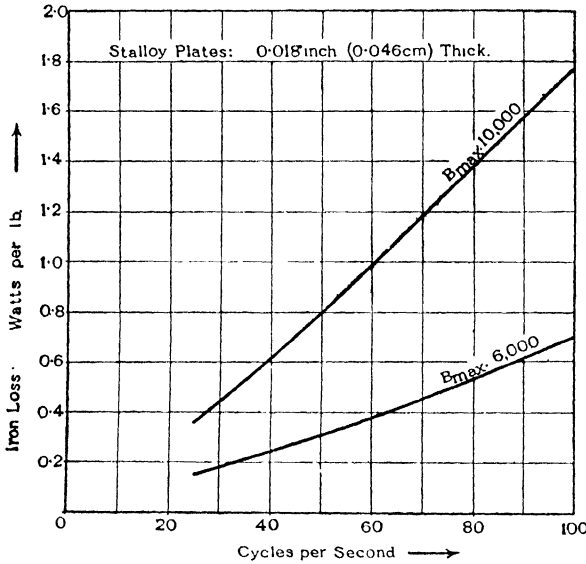

FIG. 124.

Now it appears from this result that if the value of $B_{\max.}$ is kept constant, and the frequency varied, the relationship between the quantity $\frac{W_i}{f}$ and the frequency f will be a straight line. This straight line will cut the axis of $\frac{W_i}{f}$, and the magnitude of the intercept will be

$$58.5 \eta B_{\max.}^{1.6} \cdot 10^{-7} \text{ joules per lb. per cycle,}$$

as is obtained by putting $f = 0$ in the expression for $\frac{W_i}{f}$.

If the value of $B_{\max.}$ is known, the value of the hysteresis constant η is at once determined.

Further, the slope of the straight line (see Fig. 125) will be such that

$$\begin{aligned} \tan \alpha &= \frac{58.5 \epsilon f (f_x B_{\max.} \Delta)^2}{f 10^7} \\ &= 58.5 \epsilon (f_x B_{\max.} \Delta)^2 10^{-7} \end{aligned}$$

Since the magnitudes of $B_{\max.}$ and Δ are known, the magnitude of the eddy current constant ϵ is immediately obtained.

In Fig. 124 the iron losses are shown for the brand of high-resistance alloyed iron known as "stalloy" (see Chapter IV, § 34),

the laminations being each 0.046 cm. thick. The losses are plotted as a function of the frequency of the alternating magnetic flux for two cases, viz., $B_{max.} = 10,000$, and $B_{max.} = 6000$, respectively.

In Fig. 125 are shown the straight lines connecting the values of $\frac{W_i}{f}$ in joules per lb. per cycle, and the frequency f .

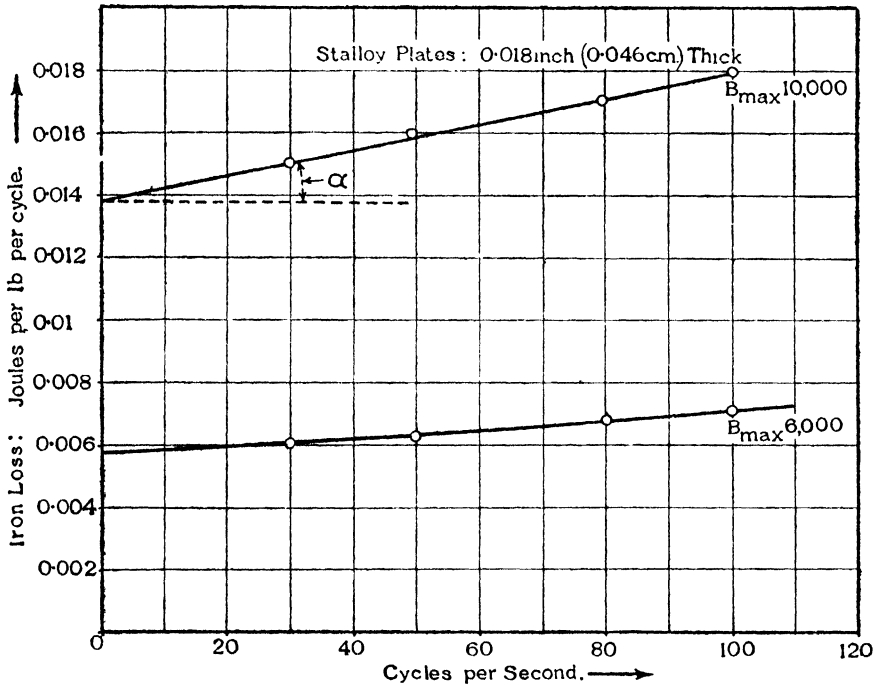

FIG. 125.

From Fig. 125 it is found that, in the case of $B_{max.} = 10,000$, the intercept of the straight line on the ordinate axis is 0.0138 joule per lb. per cycle, so that the hysteresis constant in this case is

$$\eta = 0.00094.$$

The slope of the straight line in Fig. 125 is

$$\tan \alpha = 41 \times 10^{-6},$$

so that

$$\varepsilon = \frac{41 \times 10^7}{10^6 \times 58.5(f_x B_{max.} \Delta)^2}$$

where

$$f_x = 1.11 : B_{max.} = 10,000 : \Delta = 0.046$$

The value of the eddy current constant is therefore found to be

$$\epsilon = 0.268 \times 10^{-4}$$

METHOD II.—*Separation of the Total Iron Losses by Measurements made at Constant Frequency and at a Series of Values of the Form Factor.*

Referring to the expression for the total iron losses given in § 74, it is seen that, for a given value of $B_{\max.}$, the hysteresis loss is independent of the form factor f_x , whilst the eddy current loss is proportional to the square of the form factor. Hence, if the form factor f_x is varied, whilst the values of $B_{\max.}$ and f are maintained constant, and if the total iron loss watts be plotted as a function of f_x^2 , a straight line will be obtained as shown in Fig. 126.

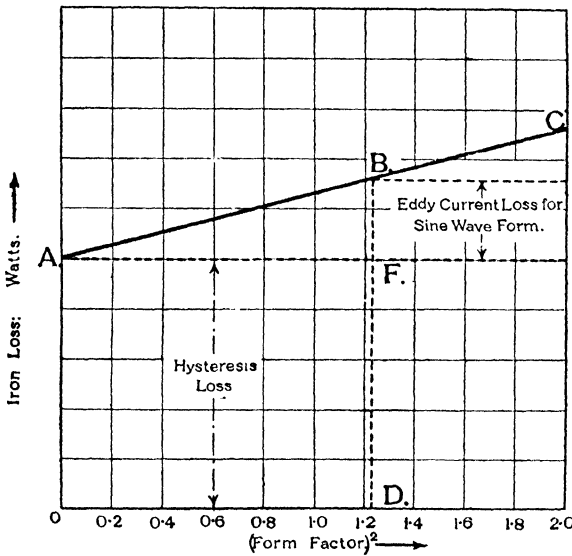

FIG. 126.

The intercept of this straight line on the ordinate axis is the hysteresis loss. To find the eddy current loss for a sinusoidal wave of alternating flux (that is, for $f_x = 1.11$), it is only necessary to read off the total watts corresponding to $f_x^2 = (1.11)^2 = 1.23$, and then subtract the hysteresis loss OA , Fig. 126.

The diagram of connections for this method by which this test may be performed is shown in Fig. 127. The form factor is varied by means of the non-inductive resistance R and the iron core inductance X , which are in series with the magnetising winding P of the magnetic square and supplied through the transformer T , of which the secondary may be provided with tapping points to vary the voltage.

Two separate secondary windings on the magnetic square are used. One of these, S_2 , is for the measurement of the *mean value* of the alternating wave of magnetic induction, and the other, S_1 , is used to supply the pressure coil of the wattmeter W and the electrostatic voltmeter V_E .

The secondary winding S_2 is connected through brushes to a pair of insulated slip-rings, and these two slip-rings are connected respectively to the two sides of a two-part commutator as shown in Fig. 127. The two slip-rings and the two-part commutator are

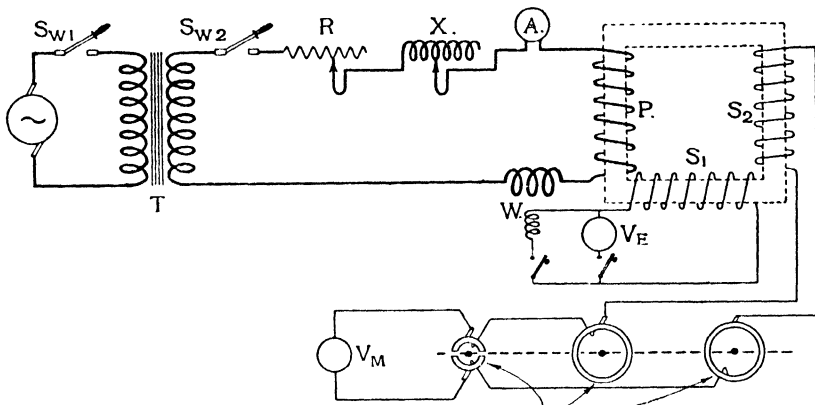

Slip rings and two part commutator driven synchronously from main a.c. supply

FIG. 127.

all mounted on the same shaft, which is driven synchronously with the same supply frequency as that to which the primary winding P of the magnetic square is connected.

The direct current voltmeter V_m is connected to the diametrically opposite pair of brushes on the two-part commutator. This pair of brushes is then moved by means of an adjustable rocker until the reading of the voltmeter V_m reaches a maximum. When this adjustment has been made, the reading of V_m will give the mean value of the wave of e.m.f. induced in the secondary winding S_2 .

The reading of the voltmeter V_E is a measure of the *root mean square* value of the alternating wave of magnetic induction. From

For an alternating wave each half of which is an equilateral triangle, the r.m.s. value is

$$V_{\text{r.m.s.}} = \frac{1}{\sqrt{3}} V_{\text{max.}}$$

the mean value is

$$V_{\text{mean}} = \frac{1}{2} V_{\text{max.}}$$

and the form factor is therefore

$$f_x = \frac{2}{\sqrt{3}} = 1.16.$$

Generally stated, a flat-topped wave has a lower value for the form factor than a peaked wave.

77. Iron Loss Data for Typical Qualities of Iron and Steel as used in Electrical Machines and Apparatus

As already stated, the total iron losses in laminated sheets may be expressed in the form

$$W_i = [\eta B_{\text{max.}}^{1.6} + \varepsilon (f_x f B_{\text{max.}} \Delta)^2] \text{ ergs per sec. per c.c.}$$

that is,

$$W_i = [\eta B_{\text{max.}}^{1.6} + \varepsilon (f_x f B_{\text{max.}} \Delta)^2] 10^{-7} \text{ watts per c.c.,}$$

or,

$$W_i = 58.5 [\eta B_{\text{max.}}^{1.6} + \varepsilon (f_x f B_{\text{max.}} \Delta)^2] 10^{-7} \text{ watts per lb.}$$

For *good armature iron*, the values of the respective constants may be taken as

$$\eta = 0.00135 \text{ and } \varepsilon = 1.22 \times 10^{-4}.$$

Inserting these values in the above expression, and assuming a sine wave of alternating magnetic induction, that is, assuming $f_x = 1.11$, the total iron loss may be written

$$W_i = 0.048 \left[\frac{f}{100} \left(\frac{B_{\text{max.}}}{1000} \right)^{1.6} + 180 \left(\frac{f}{100} \right)^2 \left(\frac{B_{\text{max.}}}{1000} \right)^2 \Delta^2 \right] \text{ watts per lb.}$$

For *high-resistance iron alloys*, the constants are considerably less than those for good armature iron. For the brand of high-resistance alloy known as "stalloy," the values of the constants are:

$$\eta = 0.00094 \text{ and } \varepsilon = 0.27 \times 10^{-4}, \text{ respectively.}$$

Again, assuming that the wave of alternating magnetic induction is sinusoidal, so that $f_x = 1.11$, the total iron loss may be expressed as

$$W_i = 0.034 \left[\left(\frac{f}{100} \right) \left(\frac{B_{\max.}}{1000} \right)^{1.6} + 58 \left(\frac{f}{100} \right)^2 \left(\frac{B_{\max.}}{1000} \right)^2 \Delta^2 \right] \text{ watts per lb.}$$

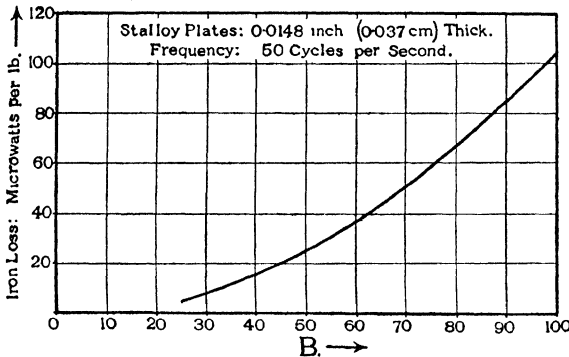

FIG. 128.

accountable for the relatively low losses due to eddy currents obtained with the high-resistance iron alloys. The enormous practical importance of reducing the iron losses as much as possible will be judged from the fact that the money value of the power loss in transformers due to iron losses is many millions of pounds sterling per annum.

The noteworthy feature of these high-resistance alloys is the fact that the specific electrical resistance is about 42.5 microhms per cm. cube, as compared with about 11.5 microhms for ordinary good quality armature iron. This high value of the specific resistance is accountable for the relatively low losses due to eddy currents obtained with the high-resistance iron alloys.

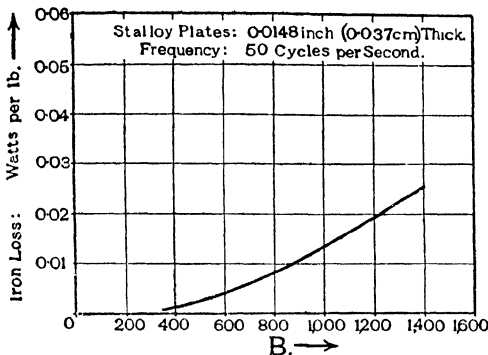

FIG. 129.

In Figs. 128 and 129 the iron losses are shown for stalloy laminations 0.0148 in. (0.037 cm.) thick. In Fig. 128 the losses are shown in microwatts (*i.e.*, watts $\times 10^{-6}$) per lb. for a range of very low values of the magnetic induction B , viz., from about 20 to 100 lines per sq. cm., whilst in Fig. 129 the iron losses are given for a range of B from about 300 to 1400 lines per sq. cm.

Figs. 130 and 131 show the iron losses as a function of the induction B for three different frequencies commonly met with in practice. Fig. 130 refers to good armature iron laminations 0.626 mm. thick, and Fig. 131 to high-resistance alloyed iron laminations 0.604 mm. thick.

78. Iron Losses in Sheet Material at High Flux Densities

In a recent paper,* C. E. Webb has given some results of tests on the power losses in magnetic sheet material at high flux densities. Some of the conclusions drawn from these tests are as follows :

(i) In all the principal types of commercial sheet material in use at the present time, the rate of increase of the hysteresis loss with B_{max} is considerably greater at flux densities above $B_{max} = 10,000$ than is indicated by Steinmetz's law, or than appears to have been generally realised. In most specimens over a small range in the neighbourhood of $B_{max} = 15,000$, the variation is as rapid as the 2.5th power of B_{max} , and in some cases it exceeds the 3rd or even the 4th power of B_{max} .

(ii) Above about $B = 16,000$, the rate of increase falls

* See *Journal of the Institution of Electrical Engineers*, April, 1926, Vol. LXIV, p. 409.

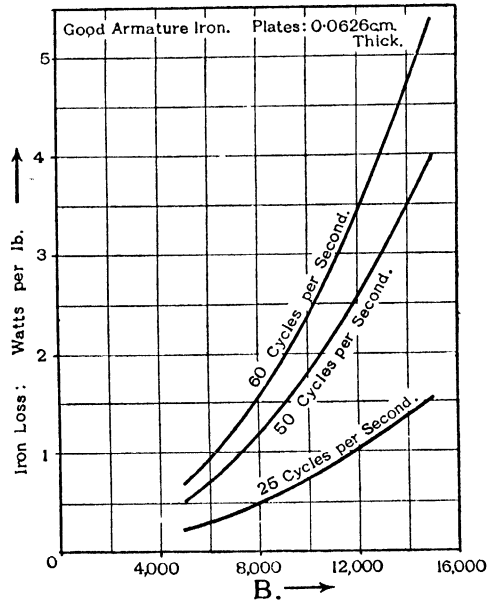

FIG. 130.

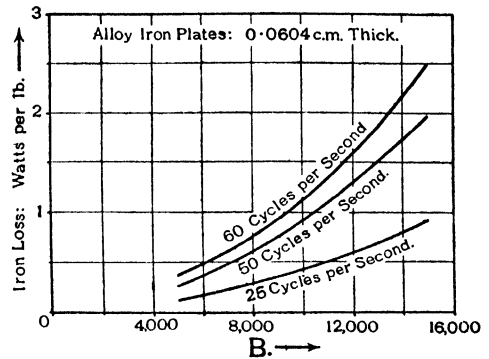

FIG. 131.

off very rapidly and drops again to the 1.6th power or even lower.

(iii) The eddy-current index (see § 74) at high flux densities is fairly constant and generally rather less than 2.

79. Skin Effect due to Eddy Currents

It is a consequence of Lenz's law of electro-magnetic induction that the eddy currents due to an alternating flux through an iron plate will give rise to a weakening of the alternating magnetic flux. This weakening action will be a maximum at the central part of the section of the plate. The resultant concentration of the magnetic flux towards the outer or skin layers of the iron is known as the "skin effect."

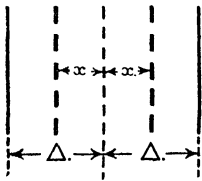

FIG. 132.

The problem of calculating the distribution of the alternating magnetic flux through the section of the plate has been dealt with by C. P. Steinmetz* and the curves given in Fig. 133 have been obtained from the equations given by him.

In Fig. 132 is shown, in diagrammatic form, the cross-section of an iron plate of thickness 2Δ cms., and the alternating magnetic flux is assumed to be passing through the plate in a direction at right angles to the plane of the paper. The resultant flux distribution will be symmetrical on each side of the central plane. Let x cms. be the distance of two planes equidistant from the central plane as shown in Fig. 132. Let B_x be the flux density in the planes distant x cms. from the central plane and let B_Δ be the flux density at the surfaces of the iron plate. In Fig. 133 the value of the ratio $\frac{B_x}{B_\Delta}$ is shown as a function of the ratio $\frac{x}{\Delta}$, for the condition that the alternating flux has a frequency of 50 cycles per second, the permeability of the iron plate is 2000, and the specific electrical resistance 10^{-5} ohm per cm. cube. The results are shown for three plates of different thicknesses, viz., 0.75 mms., 1.5 mms. and 3.0 mms., respectively.

* See "Transient Electric Phenomena."

It will be seen that even for a plate only 0.75 mm. thick there is an appreciable weakening of the flux at the central part of the plate, whilst for the plate which is 3.0 mms. thick the flux is almost wiped out at the central part of the plate.

If the penetration σ of the magnetic flux into the plate be defined as the thickness in cms. of the surface layer which at constant

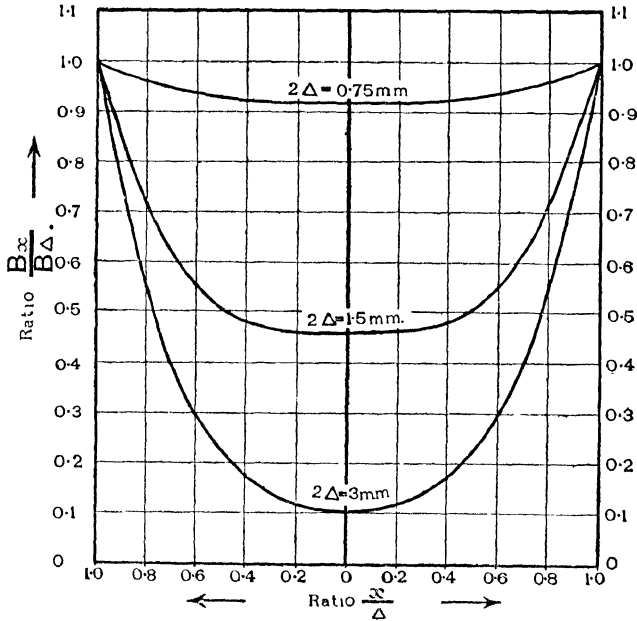

FIG. 133.

induction, equal to the actual surface induction B_Δ , would give the same total flux as actually exists, it may be shown that the following relationship holds, viz. :

$$\sigma = 3570 \sqrt{\frac{\rho}{\mu f}}$$

where ρ is the specific electrical resistance of the plate,
 μ is the magnetic permeability of the plate,
 f is the frequency of the alternating magnetic flux.

As illustrative examples the data given in the following table will serve. The value of the penetration σ in cms. is given for soft iron and for cast iron respectively for a series of frequencies.

TABLE.

Frequency. Cycles per second . . .	25	50	500	100,000
Soft Iron : $\mu = 2,000 : \rho = 10^{-5}$. .	0.050	0.036	0.0113	0.0008
Cast Steel : $\mu = 1,000 : \rho = 2 \times 10^{-5}$.	0.101	0.071	0.023	0.0016

It is clear from these results that even at the low value of the frequency of 50 cycles per second, the penetration of an alternating magnetic flux in iron or steel is very small. This is a characteristic which has an important bearing on the design of the magnetic circuit of apparatus which is intended to be operated by an alternating magnetic flux such as electro-magnets, etc. (see also § 80).

80. Permeability Tests at very High Frequencies

Several investigators have studied the behaviour of iron at very high frequencies. E. F. W. Alexanderson, using his own design of alternator, measured the permeability at frequencies varying from 40,000 to 200,000 cycles per second, and for values of B_{\max} from 450 to 1500. He found that, after allowing for eddy current effects, there was not much difference in the permeability at very high frequencies used in radio engineering and at the low frequencies common in heavy current electrical engineering.

Silsbee made measurements of the permeability of fine iron wire at frequencies up to 350,000 cycles per second, using a Poulsen arc as the high-frequency generator. He also found that, after correcting for the eddy current effect, the permeability was independent of the frequency.

CHAPTER XV

SCOTT'S METHOD FOR OBTAINING THE HYSTERESIS LOOP FOR TRANSFORMER CORES

81. Description of the Method

THIS method provides a simple and rapid means for measuring the hysteresis loss in a transformer. The readings taken during the test give the necessary data for plotting the hysteresis loop when the winding data and cross-sectional area of the core of the transformer are known.

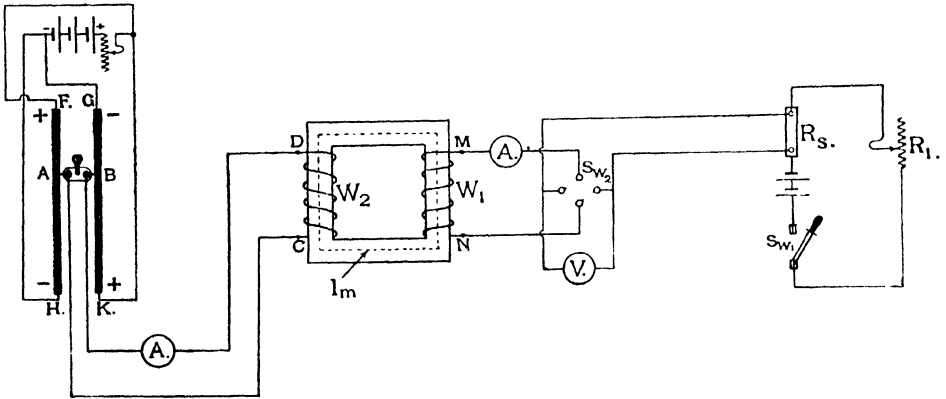

FIG. 134.

The procedure will be clear by reference to the diagrammatical sketch of connections given in Fig. 134. The characteristic feature of the method is the use of a special mercury double slide. Two channels of mercury FH and GK are connected at each end to a battery so that the two channels are in parallel across the battery. The neighbouring ends, however, of the two channels are of opposite polarity. That is to say, the end F of one slide being connected to the positive pole of the battery, the neighbouring end G of the other slide is connected to the negative pole of the battery. Two strips of copper A and B are immersed one in each mercury slide. These two strips are insulated from each other and are conveniently fixed to a wooden block provided with a suitable handle or grip. These two contacts are connected to the respective ends of the

primary (high-tension) winding of the transformer, and included in the circuit is an ammeter.

Inspection of the diagram will show that if the sliding block is moved so that the contacts A and B are immersed in the ends F and G , respectively, of the mercury slides, the current will flow through the primary winding of the transformer in the direction from C to D . If the sliding block is moved to the other end of the slider frame so that the contacts AB are immersed in the respective ends HK of the mercury slides, the current will flow through the primary winding of the transformers in the direction from D to C . That is to say, as the sliding contacts are moved from the ends FG to the ends HK the current in the primary winding becomes reduced in magnitude, passes through the zero value, and then reverses in direction. The current variation can be made as gradual as may be desired, changing from a given positive value to a precisely equal negative value.

As the current in the primary winding is thus varied, the flux in the transformer core will also vary in a corresponding manner, and, consequently, an e.m.f. will be induced in the secondary winding. By suitably adjusting the speed at which the sliding contacts A and B are moved, it is possible to ensure that the induced e.m.f. in the secondary winding shall be constant in magnitude.

To measure the magnitude of the induced e.m.f. in the secondary winding, and to ensure that it shall be constant, it is convenient to balance this e.m.f. by a p.d. obtained from a few secondary cells as shown in the diagram, Fig. 132. The p.d. which is tapped off a resistance RS is connected through the switch SW_2 so that it is brought across the terminals of the secondary winding in opposition to the induced e.m.f. Included in this circuit is a milliammeter, A . When the induced e.m.f. in the winding W_1 is equal to the applied p.d. as measured by the voltmeter V , no current will flow in the ammeter.

The test therefore comprises the movement of the sliding mercury contacts A and B at such a rate that no current is indicated by the ammeter A .

The required value for the p.d. applied in opposition to the induced e.m.f. in the winding W_1 depends upon the constants of the transformer (*i.e.*, the winding data and the cross-sectional area of the core), the peak value of the induction density for which the hysteresis loop is required, and the speed at which the slider contacts are moved. This will be evident from an inspection of the formulæ developed in the following. The magnitude of the extreme positive and negative values of the current to be carried by the winding W_2 also depends upon the constants of the transformer.

The actual readings to be taken are simultaneous measurements of the *time* and the *current in the winding W_2* , the controlling requirement being that the induced e.m.f. in the winding W_1 shall be constant throughout the test.

Let A sq. cms. be the cross-sectional area of the core of the transformer,

„ w_1 be the number of turns in the winding W_1 ,

„ w_2 be the number of turns in the winding W_2 ,

„ e_1 volts be the induced e.m.f. in the winding W_1 ,

„ l_m cms. be the mean length of the magnetic circuit in the transformer core,

„ i_2 amperes be the current at any moment in the winding W_2 of the transformer,

„ B lines per sq. cm. be the flux density in the transformer core,

„ H gauss be the magnetic force along the mean magnetic path due to the current of i_2 amperes,

„ t seconds be the time of duration of the sliding operation measured from the commencement of the movement of the sliding contacts.

In Fig. 135 is reproduced a curve ABC taken in an actual test

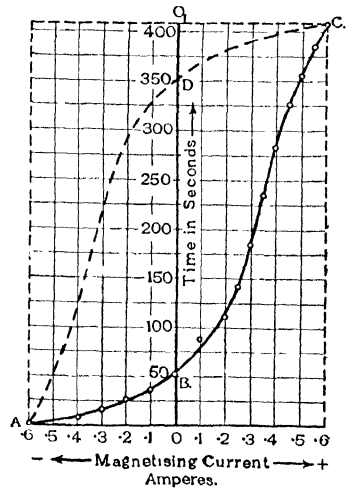

FIG. 135.

and showing the simultaneous values of the current i_2 in the winding W_2 and the time in seconds. The current has been varied from the negative value -0.60 ampere to an equal positive value $+0.60$ ampere.

If now a similar test be taken in which the current is varied from the positive value $+i_2$ amperes to an equal negative value $-i_2$ ampere, and if, in plotting the readings for this test, the origin for the time scale is taken at O_1 , the curve CDA will be obtained. The two curves together form a closed loop, and it will be found that the curve CDA is of the same shape as the curve ABC , *e.g.*, the point D on the one curve corresponding to the point B on the other curve.

82. Construction of the Hysteresis Loop

The e.m.f. induced in the winding W_1 is

$$e_1 = \frac{w_1 A}{10^8} \frac{dB}{dt} \text{ volts.}$$

As already stated, the sliding contacts A and B (Fig. 132) are so operated that the value of this induced e.m.f. is maintained constant. Hence

$$\frac{dB}{dt} = \frac{e_1 10^8}{w_1 A} = K_1$$

where K_1 is a constant.

That is,

$$B = K_1 t.$$

It is seen, therefore, that the time in seconds is directly proportional to the flux density B in the transformer core. Further, the value of the magnetising force along the mean magnetic path of the transformer core is given by

$$\begin{aligned} H &= 1.26 \frac{w_2}{l_m} i_2 \\ &= K_2 i_2 \text{ gauss,} \end{aligned}$$

where K_2 is a constant.

From these relationships, it is possible to transform the ordinates (time) in Fig. 135 into values of the induction density B , and the abscissæ (*i.e.*, the current i_2) into values of the magnetising force H .

The hysteresis loss corresponding to the loop shown in Fig. 136 is therefore

$$\left[\frac{\text{Area of the hysteresis loop } KFGLF_1G_1}{4\pi} \right] \text{ ergs per c.c. of iron core per cycle,}$$

$$= 950 \text{ ergs per c.c. of iron core per cycle.}$$

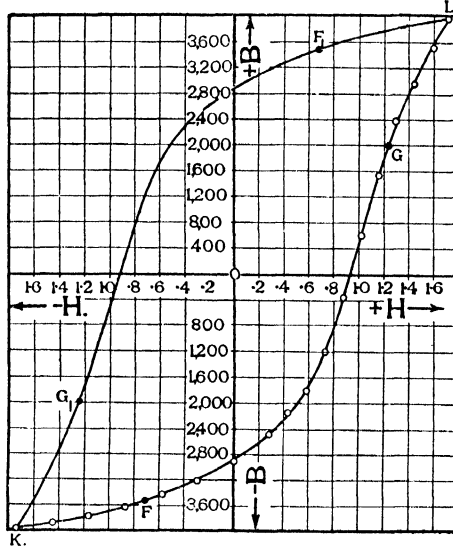

FIG. 136.

Hence

$$\eta B_{\max.}^{1.6} = 950,$$

and since

$$B_{\max.} = 4000,$$

the value of the hysteresis constant is found to be in this case

$$\eta = 0.0017.$$

If the transformer is operated at a frequency of 50 cycles per second, the power loss in hysteresis for the peak value of the induction $B_{\max.} = 4000$, will be

$$\frac{950 \times 50 \times 6637}{10^7}$$

$$= 31.7 \text{ watts.}$$

TESTING PERMANENT MAGNETS: TESTING FOR MECHANICAL AND OTHER DEFECTS IN STEEL BY MAGNETIC METHODS: TESTING FEEBLY MAGNETIC SUBSTANCES.

83. The Testing of Permanent Magnets

As explained in Chapter II, § 22, the most important magnetic characteristic of a permanent magnet is the part of the demagnetisation curve between the remanence point C and the coercive point F (Fig. 138), and the accurate determination of this curve is a matter of great practical importance.

Permanent magnets may be of a great variety of shapes, and for the determination of the demagnetisation curve the use of both H search coils and B search coils is generally necessary.

In the case of a uniformly magnetised ring specimen, the value of H may be calculated from the data of the magnetising winding and the dimensions of the ring. In the case

of a bar magnet or a horse-shoe magnet, the value of H cannot be calculated in the same way on account of the effect of the magnetised ends of the magnet and the leakage from the flanks.

The value of the magnetising force H at any part of a magnet is given by the flux density in the air at the surface of the magnet. In Chapter XII, § 65, the use of search coils wound so as to embrace the section and connected up differentially has been considered, and it has been shown that these coils may be used for the measurement of both H and B .

For some purposes, the use of one or more search coils placed very near to the surface of the magnet but not linked with it, may be convenient for measuring H , as shown in Fig. 137. Flat search coils

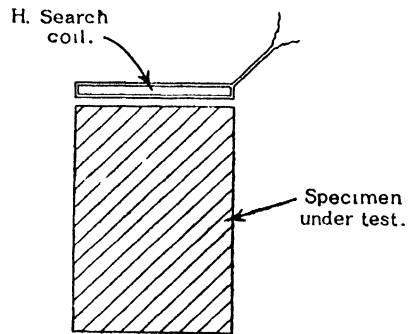

FIG. 137.

Referring to Fig. 138, if the throw given by the H search coil corresponds to the amount SK when the current is changed from $+I_{\max.}$ to 0, the throw given by this search coil when the current is changed from 0 to $-I_{\max.}$ will be KT . The difference between these two quantities, viz., $SK-KT$, will be $2OK$, so that half the difference of the two throws from the H search coils will correspond to the magnitude OK which is the abscissa of the point D .

If the throw given by the H search coil when switching the magnetising current from $+I_{\max.}$ to 0 is less than the throw when switching from 0 to $-I_{\max.}$, the point D will be at the right-hand side of the ordinate axis OC .

The value of KD for the point D is obtained from the B search coil as follows: (i) The throw from the B search coil is obtained when the magnetising current is reversed from $+I_{\max.}$ to $-I_{\max.}$, the height AS corresponding to half this throw. (ii) The throw is measured when switching the magnetising current from $+I_{\max.}$ to 0, this throw corresponding to the amount AN . The height DK is then equal to $AS-AN$.

In order to increase the accuracy of the determination of the points on the curve CDF , the following method may be used.*

A mutual inductance is included in the circuit, the primary being in circuit with the magnetising winding and the secondary in circuit with the H search coil. By this means it is possible to accurately balance out the throw due to the reversal from $+H_{\max.}$ to $-H_{\max.}$.

Having obtained this condition, the sensitivity of the galvanometer can be greatly increased by reducing the resistance connected in series with it.

The following gives the routine of the process which may be followed:

- (1) Using the B search coil, find the value of the magnetising current $-I_1$ which corresponds to the point F . For this point, the throw obtained in reducing the magnetising current from

* See Campbell and Dye, *Journal of the Institution of Electrical Engineers*, 1915, Vol. LIV, p. 35.

+ $I_{\max.}$ to $-I_1$ must be half the complete throw when reversing the magnetising current from + $I_{\max.}$ to $-I_{\max.}$.

(2) The mutual inductance in circuit with the H search coil is now set so that no throw is obtained from the H search coil when the magnetising current is reversed from + $I_{\max.}$ to $-I_{\max.}$.

(3) By switching the current from + $I_{\max.}$ to 0, the throw will be that corresponding to the force OK for the point D , and, as previously explained, the point D usually will not be coincident with C , the true remanence point.

(4) The mutual inductance is now set at zero and the magnetising current changed from 0 to $-I_1$, the value determined in the process (1) above. The throw from the H search coil now gives KF and, knowing OK from the result of process (1), the point F is obtained, since $OF = OK + KF$.

(5) For a further point M near the remanence point C , readings are taken when the magnetising current is changed from + $I_{\max.}$ to a small positive value + I_2 . The throw from the B search coil gives the height MP .

The current is then switched off, thus bringing the magnetic condition to D . The reading obtained from the H search coil gives the amount PK , and since OK is known from process (1) above, the amount OP is at once obtained and the point M is thus completely determined.

In testing horse-shoe-shaped permanent magnets, a similar procedure may be followed. The magnetising coil may be wound in sections, so that they may be slipped on to the magnet. For the bent portion of the magnet two or three short sections may be used and longer sections for the straight limbs. In this way the whole of the magnet may be utilised to accommodate the magnetising winding, and even when this is done, it will be necessary to work the magnetising coils at a high current density in order to obtain the high values of $H_{\max.}$ which are required for testing permanent magnets.

The magnetic circuit may be closed by means of a soft iron keeper placed across the poles of the magnet.

84. Correlation of the Magnetic and Mechanical Properties of Steel

During recent years a large number of very important experimental investigations have been undertaken with a view to employing the results of magnetic tests of steel as a means for ascertaining its mechanical and other physical properties.

This work is in a state of rapid development, and it is difficult to over-estimate the practical importance of the possibilities of the method for such purposes as testing haulage and winding ropes in mines, testing for flaws in steel rails, rifle-barrel steel, etc.

An outstanding feature of this method of testing is that it permits of the detection of flaws without in any way interfering with the structure of the material, and can be applied, for example, in the case of highly polished and finished cutlery blades, without producing any blemish on the finished surfaces.

Perhaps the most thorough and systematic investigations on these lines have been undertaken by the United States Bureau of Standards, and a number of detailed results have been given in the *Proceedings* of the American Society for Testing Materials, Philadelphia. Some of these results are reproduced in what follows.

Experiment shows as an indisputable fact that the magnetic and mechanical characteristics of steel are very closely related, and the results already obtained are sufficient to establish the conclusion that the commercial application to shop routine practice of the method of magnetic testing for mechanical flaws or defects in heat treatment is possible. For example, up to a limit, an increase in the carbon content in steel produces, on the one hand, an increase in hardness and tensile strength and a decrease in ductility, whilst, on the other hand, increasing the carbon content decreases the permeability and the saturation intensity and increases the coercive force and the hysteresis loss. Further, an increase in the rate of cooling from above the critical temperature has approximately the same effect on the mechanical and magnetic properties of steel as an increase in the carbon content.

As an illustrative example of the effect of heat treatment on the

magnetic characteristics of steel the curves and other data given in Fig. 139 will serve. These results were obtained with an alloy steel of the following composition :

Carbon	0.640 per cent.
Nickel	0.630 „ „
Chromium	0.580 „ „
Manganese	0.510 „ „
Silicon	0.210 „ „
Sulphur	0.038 „ „
Phosphorus	0.013 „ „

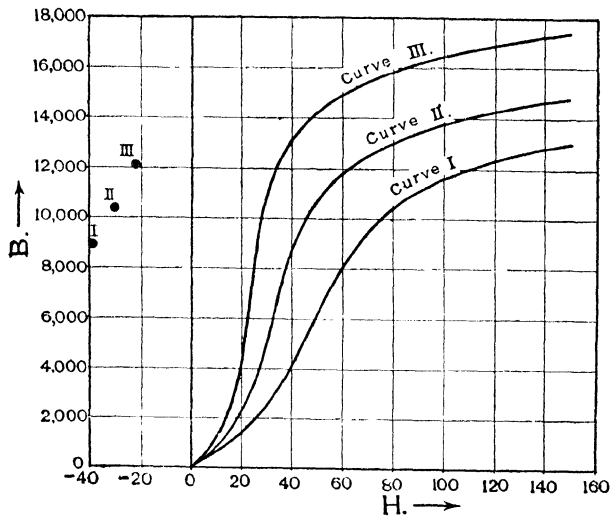

FIG. 139.

In Fig. 139, Curve I shows the magnetisation curve when the steel had been oil-quenched from 800°C ., Curve II the magnetisation curve after “drawing” * to 266°C ., and Curve III after “drawing” to 286°C .

For each of the three conditions specified, the remanence and coercive force are shown by the points I, II and III, marked in on the left-hand side of the ordinate axis of Fig. 139. These values were obtained after magnetising the steel with a magnetising force H_{max} of

* The process of reheating the steel after quenching and then allowing it to cool slowly is termed “drawing.”

150 gauss. It will be observed that a high value of the coercive force and a low value of the remanence are associated with Curve I, whilst lower values of the coercive force and higher values of the remanence are associated with Curves II and III.

85. Testing for Flaws in Wire Ropes by Magnetic Method

Many attempts have been made during the last twenty years to devise a satisfactory magnetic method for testing the soundness of steel wire ropes, *e.g.*, the hoisting ropes as used in mines. Such a method of testing offers great attractions—it is non-destructive and would permit of a rapid daily test of the rope before being put into service. Hitherto, however, not much practical success has been obtained, since the effect of even large flaws in the rope have been masked by the effect of internal stresses and it has not been found to be possible to separate the two effects with any degree of reliability.

In broad outline, the magnetic method is as follows: The wire rope to be tested is surrounded with a search coil and a magnetising solenoid, the search coil being arranged at about the central part of the solenoid core.

By exciting the magnetising solenoid with direct current, a magnetic flux is produced in the rope under test, and as the rope is run through the solenoid any change in the magnetic homogeneity produces a corresponding change in the flux and so induces an e.m.f. in the search coil. By connecting the search coil to a sensitive mirror galvanometer and receiving the spot of light on a photographic film wrapped on a revolving drum, it is possible to obtain a record of the e.m.f. induced in the search coil. If the method is a satisfactory one, an examination of this record should then make it possible to detect and locate the flaws.

The difficulties of putting such a method into practice are great and are well illustrated by the records reproduced in Fig. 140.* In Fig. 140A the record is shown as taken from a sample of stream line

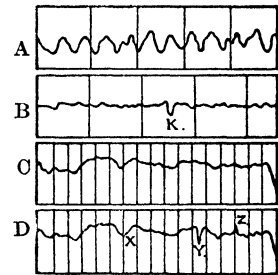

FIG. 140.

* See R. L. Sanford, *Electrical World*, August 15, 1925, p. 309.

wire as is sometimes used in aeroplane construction. So far as could be ascertained from evidence available, this wire had no defects or flaws, and mechanically was sound and satisfactory. The record shows a periodic curve and the length of the period corresponds with the circumference of the 8-in. roll with which the wire was rolled to the stream line section.

Fig. 140B refers to a wire which originally showed little variation in magnetic permeability throughout its length and was intentionally injured at *K* by bending it at right angles and straightening it out again. It is to be observed that the resultant change in permeability due to the injured place is actually less than the variations found in the first wire, Fig. 140A, which was perfectly sound.

In Fig. 140C is shown the record obtained from steel wire as used for the manufacture of wire ropes.

In Fig. 140D is shown the record for the same steel wire rope as in Fig. 140C, but in this case intentional flaws were given to the rope as follows :

- At *X* a notch was filed in the rope,
- At *Y* the rope was bent,
- At *Z* the rope was heated with a match.

An examination of the record, Fig. 140D, shows that the effect of the artificial notch *X* was so small that it would certainly have been overlooked completely in comparison with the other irregularities as given in the normal record of Fig. 140C for a sound rope.

The records in Fig. 140 emphasise the great difficulties hitherto encountered in attempting to successfully apply the magnetic method of testing wire ropes as a commercial process.

The United States Bureau of Standards,* however, have made an important contribution to the solution of this problem which appears to place the method on a sound practical basis for the first time so that rapid progress should now be possible in the practical development of this method.

The new modification, which marks a notable advance, is this.

* See R. L. Sanford, *loc. cit.*

Instead of using moderate values for the magnetising force H as hitherto has been the case, very much more intense magnetising forces are used. The effect of this improvement is well illustrated in Fig. 141.

The records in Fig. 141A and Fig. 141B were taken with the same rope as was used for the records given in Fig. 140C and Fig. 140D.

The record in Fig. 141A was obtained when the value of the magnetising force H was 20 gauss, and the record in Fig. 141B was taken when the magnetising force was increased to 100 gauss.

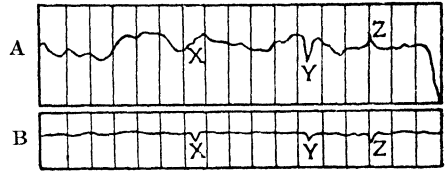

FIG. 141.

An examination of Fig. 141B at once reveals the vitally important fact that the effect of the variations due to internal stresses in the rope have been practically wiped out, whilst the effect of the flaws X , Y and Z are plainly visible.

Further, by comparing Fig. 141B with Fig. 140D it is seen that the effect of heating the rope has been reversed.

The explanation of the successful elimination of the variations due to internal stresses in the rope will be understood by refer-

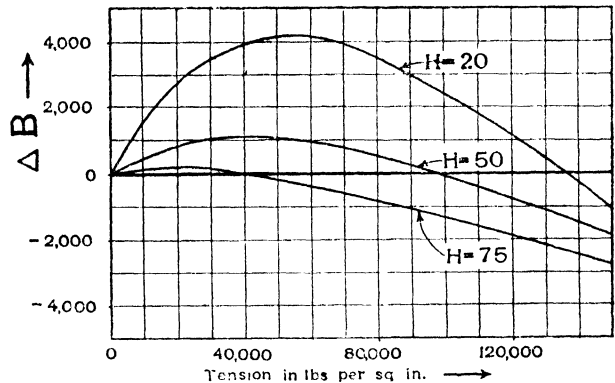

FIG. 142.

ence to Fig 142, which is the same as Fig. 70, Chapter VI. As already explained in Chapter VI, § 42, mechanical stress has an effect on the magnetic permeability of steel, and subjecting a steel wire to mechanical stress may either increase or decrease the permeability according to the particular values of the magnetising force and the stress which are simultaneously acting (see Figs. 67—70).

In Fig. 142 the increase or decrease ΔB of the magnetic induction due to a given value of the stress is plotted vertically, whilst the corresponding values of the stress are plotted horizontally, as has been explained in detail in Chapter VI.

It will be seen from Fig. 142 that for stresses up to about 50,000 lb. per sq. in., and for a magnetising force $H = 75$ gauss, the effect of stress on the permeability is practically zero, whereas if, for example, the value of the magnetising force is reduced to $H = 20$ gauss, the effect of stress on the permeability is very large. Thus, by increasing the value of H suitably, the effect of internal stresses on the record of the e.m.f. induced in the search coil is practically wiped out. If, however, there are dangerously high stresses developed in the rope, say, stresses greater than about 75,000 lb. per sq. in., due to the wear or rupture of one or more strands, the effect of this flaw will show up in the record as a reduction of the permeability of the rope.

86. Magnetic Method for Testing Steel Rails for Mechanical Flaws

The magnetic method is the only practical one available which, by a non-destructive test, shows whether two steel rails or bars are identical or whether two portions of the same rail or bar are identical, that is, whether blow holes, fissures, strains, etc., are existing in any part.

Briefly stated, the procedure is as follows: An exciting solenoid is provided, the rail under test being passed through the solenoid and moved along at a uniform speed. One or more search coils are fitted within the solenoid, being wound on a former which closely embraces the rail.

The general arrangement is shown diagrammatically in Fig. 143. The rail under test is supported on massive steel blocks AA , and the return path for the magnetic circuit is provided by the massive steel beam DD . The path of the magnetic flux will then be along the rail, across the supporting blocks AA , and back through the steel beam DD .

If the steel rail under test were absolutely homogeneous in every part in so far as its magnetic characteristics are concerned, the magnetic leakage from the surface would be more or less uniform throughout its length except at places near the blocks *AA*. If there are mechanical flaws, hardness, or other inhomogeneous part in the rail, there will be a change in the magnetic leakage in the neighbourhood of that part. The e.m.f. induced in the search coil which is moved along the surface with the exciting solenoid will therefore show a corresponding change in magnitude. Hence, if a continuous record of the induced e.m.f. in the search coil be taken as the coil and solenoid move along the rail, an examination of this record will make it possible to detect and to locate the flaws.

The record of the voltage induced in the search coil is taken photographically by means of a film mounted on a rotating drum and which receives a spot of light from the galvanometer to which the search coil is connected.

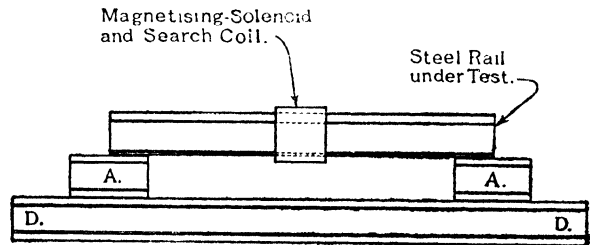

FIG. 143.

The results of some tests made on two rails by this method will now be given. One of the specimens, which was a 30 ft. length of 100 lb. rail, was sawn into two parts. These are denoted by the letters *A* and *B*, respectively, in what follows. The second specimen was a 20 ft. length of an 80 lb. rail, and this is denoted by the letter *C*.

The first specimen (that is, the parts *A* and *B*) was from the same heat as another rail which broke in service and caused a wreck, whilst the specimen *C* itself broke in service and caused a wreck.

The specimens were examined as received and also after certain artificial flaws, such as drill holes and saw-cuts, had been made in

them. The magnetic examination of the part A revealed the following results :

(i) There were a number of pairs of hard and soft portions corresponding to the number of ties on which the rail rested.

(ii) The maximum magnetic hardness was found to be at places approximately at the centres of the portions of the rail which rested on the ties.

(iii) Near the end containing the splice bar holes was a region which was relatively soft, magnetically.



FIG. 144.

A saw slot of about 1 mm. width was then cut across the head of the specimen B. This slot removed about 10% of the cross-section of the rail, and in order to minimise the effect of this reduction of cross-section, the slot was filled with strips of high permeability

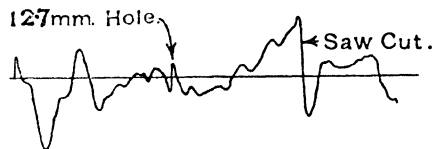

FIG. 145.

steel. In this way an imitation of a transverse fissure was obtained.

The rail was then examined magnetically by using two search coils connected in opposition and displaced longitudinally relatively to one another. The magnetising solenoid and test coils were then moved along the rail as previously explained, and a record was taken of the induced e.m.f. in the search coils. This record is given in Fig. 144, and it will be seen that the effect of the saw-cut is very clearly marked.

In order to find out whether the method was capable of showing

up a flaw in the web of a rail, records of the search coil e.m.f. were taken after holes of various sizes had been drilled in the web. The result obtained when a hole of 12·7 mms. was drilled in the web is given in Fig. 145.

As regards the specimen C, which, as already stated, was a rail which had broken in service, the magnetic record is shown in Fig. 146, a single search coil being used when this record was taken. The significant result is obtained that there were nine magnetically hard regions more or less regularly spaced. An inspection of the rail showed that these hard portions were those which had rested on the ties. It is therefore sufficiently clear that the contact pressure

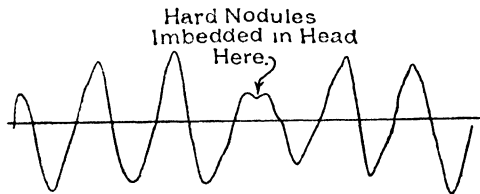

FIG. 146.

of the ties and other service conditions had had the effect of producing a change in the structure of the steel.

87. The Magnetic Examination of Cutlery and Drills

The examination of knife blades and other cutting tools is an important practical application of the magnetic method of testing materials. Essential requirements which a satisfactory blade must fulfil are that it is free from flaws and that it will take and hold a fine edge—the edge not being easily turned over or broken. In other words, the blade shall have a high degree of both hardness and toughness. These two qualities are to some extent conflicting, and experience has shown that the best result is obtained by quenching the steel from above the critical temperature and drawing it to a temperature which depends upon the dimensions of the blade and the purpose for which it is intended to be used.

If quenching is too severe, cracks are formed in the blade, and these cracks may not be discovered until a good deal of expensive

work has been done and the blade has been ground and polished. If the quenching is modified in order to avoid the cracks, the result is that an insufficient degree of hardness is obtained. It is to be observed that the process of "drawing" gives an increase of toughness at the expense of the hardness.

Magnetically, then, the problems of testing knife blades are as follows :

(i) To determine the magnetic characteristics of heat-treated blades in the rough, which may be used as criteria for separating cracked blades from sound ones.

(ii) To determine the magnetic characteristics of the finished blades which possess the requisite mechanical properties.

A great deal of work in this connection has been done by the United States Bureau of Standards, and Burrows and Fahy have summarised the position as follows :

(1) The proper hardness of the finished knife blade may be stated in terms of the coercive force. This test will sort out the faulty material from that which is sound and will enable the good blades to be classified in the order of merit.

The valuable feature of this test is that it does not injure or mar in the slightest the highly polished and finished blade.

(2) A magnetic examination of a blade as it comes from the quenching bath will tell at once whether or not the blade is cracked or has been so badly strained in quenching that cracks are liable to develop under further mechanical or heat treatment. This test enables the faulty blades to be discarded before any expensive work has been done on them. The test can also detect under-quenching and thus provides an opportunity for retreating the blades immediately without waste of time or labour.

As regards the testing of drills by the magnetic method, it may be observed that a test of the coercive force enables the good drills

to be separated from the bad ones, that is to say, the drills which have been properly heat treated from those which are defective in this respect. The test also allows the drills to be classified in the order of merit.

88. Tests on Ball-bearing Races

A method has been used by Sanford and Fischer for testing ball-bearing races which depends on the fact that if a piece of steel, *e.g.*, a steel ring, is placed in a slowly rotating magnetic field, a torque will be exerted on it due to magnetic hysteresis. Assuming that the speed of rotation is so slow that the magnitude of the eddy currents is small, it is easy to show that the magnitude of the torque is proportional to the energy loss in hysteresis per revolution and that the torque is consequently independent of the speed of rotation of the magnetic field.

Experiment shows that the magnitude of the hysteresis torque is a measure of the mechanical hardness of the ring under test.

Tests were made by supporting the ball race between the poles of a powerful electro-magnet, which was slowly rotated. The ball race was clamped on a self-centring holder at the end of a shaft mounted in ball bearings and supported from above. The torque was balanced by means of a spiral spring, and the deflection of a pointer attached to the spring gave the magnitude of the hysteresis torque.

Experiments have shown that it is possible by this means to detect flaws which are invisible. Upon breaking such faulty rings with a hammer, however, rust marks were found which indicated the presence of cracks.

The method is also able to give a good indication as to whether the heat treatment to which a ball race has been subjected has been satisfactory. For example, in the following table are given the readings of the hysteresis torque for a series of groups of ball races. Each group comprised six rings, and the average result of the six is given for each group.

TABLE.

Group No.	Quenching Temperature.	Torque Reading.
1	732° C.	35
2	760° C.	68
3	788° C.	69
4	815° C.	73
5	843° C.	66

It will be observed that the value of the torque increases progressively with the quenching temperature with the exception of the group no. 5. Other things being the same, the torque reading for this group should have been the highest of all, and in order to investigate the cause of the inconsistency, the heat records were examined. It was then found that in the case of this group the rings had been overheated by 28° C., and then allowed to cool until the rings were 56° C. below the desired temperature before they were reheated. It is thought that this treatment had the effect of decarbonising the outer surface to some extent, thus giving the low reading for the torque.

Tests were also made as to the effect of "drawing" the quenched rings to various temperatures, and it was found that a sharp drop in the torque reading occurred for drawing temperatures between 200° C. and 300° C. It is within this range of temperatures that the magnetic transformation of cementite (Fe_3C) occurs.

89. Thermo-magnetic Analysis

If iron or steel be heated within a moderate range of temperature, say, up to about 400° C., and if the intensity of magnetisation J be plotted as a function of the temperature for a given value of the magnetising force, the curve so obtained has a shape which is characteristic of the composition of the iron or steel (see, for example, Chapter III, Fig. 34). Making use of this phenomenon, the plotting of such curves provides a basis for the non-destructive analysis of steel.

This method is now receiving a considerable amount of attention

and there is reason to believe that it will provide a valuable means for determining the composition of iron and steel.*

90. Tests on Non-magnetic Steels

The so-called non-magnetic steel and iron, for example, non-magnetic cast iron (see Chapter IV, §§ 34 and 36), require somewhat special methods for determining their characteristics. One method of doing this is as follows: Suppose a bar of the substance is placed at the central part within the core of a long solenoid and that a search coil is provided embracing the specimen and wound with a large number of turns, the arrangement being such that the specimen may be removed without interfering with the search coil. In circuit with the solenoid is the primary of a calibrated air core mutual inductance, the secondary of which is in circuit with the ballistic galvanometer. The necessary adjustments are then made, so that when the specimen is removed no throw of the galvanometer is obtained when the current in the solenoid is reversed. That is to say, the e.m.f. induced in the search coil by the magnetic flux through the search coil due to the magnetising field H is balanced out by the e.m.f. induced in the same circuit by the mutual inductance.

If the specimen is now placed in position in the solenoid, the throw of the galvanometer will be a measure of the intensity of magnetisation J , where

$$J = \frac{B - H}{4\pi}$$

The intensity of the magnetic force at the central part of the solenoid is calculated by means of the relationship

$$H = \frac{4\pi}{10} \text{ (ampere-turns per cm. length),}$$

and it may be assumed that, in the case of the very low permeability steel and cast iron for which this method is applicable, the effect

* See also *Revue de Métallurgie*, 1925, Vol. XXII, p. 27, and Benedicks, *Journal of the Iron and Steel Institute*, 1926.

on this calculated value of H due to the magnetised ends of the specimen is negligibly small.

91. Susceptibility of Feebly Magnetic Substances

It was stated in Chapter I, § 8, that the susceptibility κ is related to the permeability μ by the equation

$$\mu = 1 + 4\pi\kappa.$$

Assuming, for example, that annealed dynamo steel has a maximum permeability of about 5000 (see Fig. 46), the corresponding value of the susceptibility is about 400 c.g.s. units.

It is sometimes necessary to measure the susceptibility of very feebly magnetic bodies for which the value of κ may be of the order of 10^{-6} . For such measurements, the usual methods employed for iron and steel are useless. The ordinary magnetometer, for example, ceases to be applicable for values of the susceptibility less than about 0.001, and special methods have to be brought into use.

A knowledge of the susceptibility of feebly magnetic substances is important when dealing with some problems in connection with the magnetic separation of ores and also in connection with magnetic survey work.

Prof. E. Wilson * has developed a method which is capable of determining susceptibilities of a very low order. The principle of operation is the relationship

$$F = \kappa \frac{1}{2} \frac{dH^2}{dx},$$

where F is the force acting upon unit volume of the substance and H is the magnetic force varying with the distance x . The apparatus comprises an electro-magnet which attracts or repels the substance according to whether it is paramagnetic or diamagnetic. The specimen is secured to one end of a horizontal beam which is supported at its centre by a phosphor-bronze strip and the pull exerted by the magnet is balanced by the force of torsion of the strip.

* See E. Wilson, *Proc. Royal Soc.*, 1920, **A**, Vol. XCV; also *Journal of the Institution of Electrical Engineers*, 1919, Vol. LVII, p. 416.

Normally, the specimen hangs between the poles of the magnet, which is capable of motion in a horizontal direction at right angles to the beam.

When it is required to make a measurement of the susceptibility, the electro-magnet is excited, and this excitation is maintained constant. The magnet is then moved forward, thus attracting the specimen in the direction x until the angle of twist is a maximum. This angle is measured by a spot of light reflected from a mirror attached to the phosphor-bronze strip supporting the beam. If the strength of the magnetic field H is known in the neighbourhood of the specimen when the deflection is a maximum, the susceptibility is given by the relationship

$$\kappa = \frac{C\theta}{H^2V},$$

where V is the volume of the specimen,
 θ is the observed maximum deflection,
 C is a constant.

The following table gives a list of some of the substances of which the susceptibility has been measured in this way.

TABLE.

Substance.	Susceptibility.
Magnetite Crystal	10
Granite	0.0012
Red Haematite	0.00020
Platinum	0.000029
Bengal ruby mica, clear, in a direction parallel to the plane of the laminae	0.000012
Limestone	0.000006
Aluminium	0.0000018
Copper	- 0.00000073
Glasses, various	{ - 0.0000015
	{ + 0.0000025
Water	- 0.00000075

INDEX

- AGEING, 50
 Air-gap, energy stored in, 24, 42, 45, 46
 Alexanderson, E. F. W., 232
 Allotropic, 64, 69
 Alpha iron, 57, 58, 63, 68, 69, 70
 Alternating current, demagnetisation by,
 19, 163, 204
 — magnetic flux, 100
 Aluminium, 87
 Aluminium-iron, 26
 American Society for testing, 243
 Ampere, 111
 — current rings, 34, 38, 40, 41, 57, 63,
 72
 Ampère-Ewing theory, 34,
 Ampere-turns, 13, 37, 38
 Analysis, thermo-magnetic, 254
 Arc rectifier, 29
 Armature iron, 227
 Armature slots and teeth, 29
 Arneo iron, 73, 82, 83, 84, 85, 86
 Arnold, H. D., 81
 Atom, 33, 34, 40, 115, 116
 Atomic current rings, 34, 38, 40, 41, 57, 63,
 72
 — number, 41
 — weight, 57, 89
 Austenite, 71

 B, magnetic induction, 12, 93
 — search coil correction, 192
 Ball, J. D., 100
 Ball-bearing test, 253
 Ballistic, constant, 141, 143, 145, 148
 — galvanometer, 139
 — test, 100
 — throw, 139
 Bar and Yoke method, 167, 171
 Beattie, 33
 Beta iron, 57, 58, 63, 69, 70
 B : H curves, 19
 — Arneo iron, 83, 84
 — carbon steel, 76, 77
 — cast iron, 77, 78
 — cobalt, 77, 78
 — cobalt iron, 78
 — cobalt-chromium steel, 82, 108
 — electrolytic iron, 76, 77, 78
 — Heusler alloy, 88
 — Japanese steel, 82
 — magnetite, 88
 — manganese steel, 88
 — nickel, 78, 87, 88
 — permalloy, 80, 82, 83
 — permanite, 82
 — stalloy, 80, 199
 — tungsten steel, 82
 — wire rope, 107

 Bidwell, S., 101
 Bismuth, 17, 88, 91, 101, 102, 104, 111
 — spiral, 91, 92
 Brake magnet, 49
 Braun, Hartmann and, 92
 "Broadside on" method, 209
 Broca galvanometer, 139
 Buckley, O. E., 81
 Burrows, C. P., 171, 252

 c, ratio of units, 112
 Cable "loading," 81
 Calibration of galvanometer, 141, 181
 — of magnetometer, 210, 211
 Campbell, 241
 Carbide of chromium, 62
 — of iron, 61, 63, 68
 — of tungsten, 62
 Carbon, 27, 61, 69, 73, 97
 — steel, 27, 61, 81, 95, 97, 99
 Carey Foster, 149
 Cast iron, 27, 74, 75, 87, 89, 91
 Cell, standard, 142
 Chromium, 61, 62, 63, 66, 72, 73, 89, 111
 Charge on electron, 112
 Clinker, 33
 Cobalt, 27, 72, 86, 87, 89, 94, 101, 104
 Cobalt-chromium steel, 46, 47, 200
 Cobalt iron, 78, 81, 87, 89
 Cobalt steel, 46, 47, 67
 Coefficient, magnetic hardness, 94, 96, 97
 — correction, 170
 — saturation, 94, 96, 97, 100
 — temperature, 59
 Coercive force, 20, 49, 166, 168, 244
 Compensating coil, 205
 — magnet, 212
 Condenser discharge, 132
 — power, 126
 — standard, 142
 Conductance, magnetic, 48
 Constant, hysteresis, 25, 26, 27, 28, 89, 216,
 223
 — eddy current, 216, 223
 Cooling curve, 63, 64
 — inverse curve, 56
 Correction coefficient, 170
 — for high values of B, 219
 — solenoid end effects, 178
 Correlation of magnetic and mechanical
 properties, 243
 Coulomb's law, 9
 Creeping effect, 201
 Curie, 118
 Current, electric, 110, 125
 — oscillatory, 126, 129, 132
 Curve, magnetisation, 19, 164, 176, 196,
 206. (*See also* B : H curves.)

- Cutlery, magnetic tests for, 251
 Cycle, hysteresis, 20, 85, 86
 — unsymmetrical, 27
 Decrement, logarithmic, 140
 Deflection, undamped, 141
 Delta iron, 57, 58, 63, 69
 Demagnetisation by a.c., 19, 163
 — curve, 43, 47, 198, 204
 — temperature, 45, 48, 89
 Density, induction, 12
 — metallic, 72, 78, 87, 88, 89, 94
 Diamagnetic, 17, 111, 119, 121
 "Drawing" of steel, 244, 254
 Duddell oscillograph, 129
 — standard inductance, 149
 Durrer, 57
 Dye, 241
 Eddy current constant, 216
 — — — loss, 215, 230
 Effects of ends of solenoids, 178
 Electric current, 110, 125
 — resistance, 55, 91, 92
 — supply meters, 49
 Electrolytic iron, 26, 73, 76, 81, 95
 Electro-magnet, 187, 253, 256
 Electro-magnetic units, 112, 113, 115
 Electron, 33, 40, 112, 113, 119
 — charge of, 112
 — periodic time, 112, 113, 119
 — theory, 112
 — velocity, 112
 Electro-static units, 112, 119
 Ellipsoidal specimens, 16, 201, 214
 Elmen, G. W., 81
 E.m.f., induced, 218
 Energy released in cooling iron, 64
 — of magnetic field, 21, 23, 41, 45, 66
 — stored in air-gap, 24, 42, 45, 46
 Evershed, S., 34, 46, 49, 54, 58
 Ewing, Sir J. A., 29, 32, 90, 101, 187
 Fahy, 252
 Feebly magnetic substances, 256
 Ferranti, 91
 Ferro-magnetic substances, 18, 111, 119, 121
 Fields, stray, 51
 — intense magnetic, 124, 188
 Fischer, 253
 Flaws, magnetic tests for, 245, 248, 251
 Flux linkages, 21, 149
 — of force, 10
 — unit of, 12
 Fluxmeter, 151
 Force, coercive, 20, 49, 166, 168, 244
 — flux of, 10
 — line of, 10
 — magnetic, 9
 — magneto-motive, 13, 14, 44, 57
 Form factor, 218, 226
 Foster, Carey, 149
 Freezing curve, 55
 Frequency, iron loss at high, 232
 — variable for separating iron losses, 221, 224
 Fröhlich, 93, 94
 Galvanometer, ballistic, 139, 184
 Gamma iron, 57, 63, 64, 69
 Gauss, 10
 Gilbert, 14
 Gore, C., 55
 Graphite, 74
 Grassot fluxmeter, 151
 Gümlich's method, 189
 H, magnetic force, 9
 — search coils, 190, 239
 Hadfield, Sir. R. A., 46, 79, 87, 187
 Hall effect, 92
 Hardness, coefficient of, 94, 96, 97
 Harmonics, zonal, 180, 182, 183
 Hartmann and Braun, 92
 High frequency, iron losses at, 232
 High resistance alloy, 227, 228
 Honda, 66, 67
 Hopkinson, B., 187
 Hopkinson, J., 59, 67, 87
 Hysteresis, 30, 32
 — constant, 25, 26, 27, 28, 89, 216, 227, 238
 — measurement of, 160, 176, 198, 207, 233
 — in weak fields, 29
 — loop, 20, 85, 86, 161, 165, 176, 198, 233, 236
 — loss, 13, 215, 237, 238
 — torque, 253
 Illinois, University testing station, 171
 Inductance, 121
 — mutual, 149, 185
 — standard, 149, 150
 Induction density, 12, 93
 Intense magnetic fields, 124, 136, 188
 Intensity, magnetic, 9
 — of magnetisation, 10, 31, 58, 59, 63, 64, 72, 117
 Inverse cooling curve, 56
 Iron, 67, 72, 76, 81, 83, 85, 86, 89, 94, 101, 102, 103
 — losses in laminations, 215
 — separation of losses, 221, 224
 Isthmus method, 187
 J, intensity of magnetisation, 10, 31, 58, 59, 63, 64, 72, 117, 201
 Japanese steel, 67, 71, 80
 Joule, 101
 Joules per cycle, iron loss, 222

- K**, susceptibility, 13, 18, 118, 120, 121, 256
 Kapitza, 126
 Kennelly, 93, 94
- L**, coefficient of inductance, 21
 Langevin, 117, 119
 Line of force, 10
 Linkages, flux, 21, 149, 186
 Logarithmic decrement, 140
 Loss, hysteresis, 13, 215, 237, 238
 Losses, iron, 215, 221, 224
- McKeehan, L. W., 81, 104, 105
 Magnetic and mechanical properties, 243
 ——— circuit, 13,
 ——— energy, 12, 41, 43, 45, 46, 48, 200
 ——— field, 124, 136
 ——— force, 9
 ——— hardness, 94, 96, 97
 ——— induction, 12, 93
 ——— intensity, 9
 ——— line of force, 10
 ——— moment, 113
 ——— pole, unit, 9, 10
 ——— potential, 23, 42
 ——— pull, 24
 ——— stability, 37, 50
 ——— susceptibility, 13, 18, 120, 121, 122,
 239, 256, 257
 Magnetisability, 93
 Magnetisation and mechanical stress, 101,
 107, 108, 109
 ——— curve, 19. (*See also* B : H curves.)
 ——— determination of, 164, 174, 196,
 206
 Magnetite, 88, 89
 Magnetometer, 201, 202, 209, 210
 Magneto-motive force, 13, 14, 44, 57
 Magneton, 122
 Magneto-striction, 101, 104, 105
 Magnets, testing permanent, 239
 Malleable iron, 75, 76
 Manganese, 18, 67, 72, 73, 74, 87, 89, 111
 Matteucci, 106
 Maxwell, unit of flux, 12
 Measurement of H by search coils, 190
 Mechanical and magnetic properties, 243
 ——— shock and magnetisation, 51, 53
 ——— stress and magnetisation, 101, 107,
 108, 109
 Meters, electric supply, 49
 Method, bar and yoke, 167, 171
 ——— of reversals, 100, 155, 160
 ——— step-by-step, 164
 Meuthen, 57
 Molecular magnets, 29
 ——— vibration, 51
 Monel metal, 89
 Morris, D. K., 59, 60
 Mutual inductance, 149, 185
 Neodymium, 18
 Nickel, 27, 67, 72, 81, 85, 87, 89, 94, 101,
 102, 103, 104, 105
 Nickel steel, 87
- Oscillograph, 129
 Oscillograms, 134, 135
 Osmond, F., 56
 Oxygen, 18, 111, 118
- Paramagnetic, 17, 111, 117, 119, 121
 Parson, 123
 Periodic time of electron, 112, 113, 119
 Permalloy, 81, 83, 84, 85, 86, 104, 106
 Permanent magnets, 49, 80
 ——— magnet testing, 239
 Permanite, 46
 Permeability, 12, 60, 61, 81, 83, 84, 85, 87,
 93, 108, 111
 Permeameter, 25, 167, 171
 Perrin, 123
 Phosphorus, 73, 74
 Pig iron, 74, 75
 Pole, magnetic, 9, 10
 ——— shoes, 28
 Potential, magnetic, 23, 42
 Poulsen arc, 232
 Pull, magnetic, 24
- Quantity of electricity, 139
- Rayleigh, Lord, 29
 Recalescence, 55
 Reluctance, 15
 Reluctivity, 93, 94, 97, 99
 Remanence, 19
 Resistance, electrical, 55, 91, 92,
 Reversal, Villari, 106, 108, 109
 Reversals, method of, 100, 155, 160
 Ritz, 123
 Ropes, magnetic test for wire, 245
 ——— permeability of wire, 108
- Sanford, R. L., 109, 245, 253
 Saturation, 30, 31
 ——— coefficient, 94, 96, 97, 100
 Scott test, 233
 Search coils for B, 192
 ——— correction for B, 192
 ——— for H, 190, 239
 Self-demagnetising coefficient, 16
 ——— force, 15
 Sensitivity, control of, 213
 Separation of iron losses, 221
 Shock, mechanical, 51, 53
 Silicon, 19, 26, 27
 Silicon iron, 73, 74
 Silsbee, 232
 Skin effect, 230, 231, 232
 Small specimens, testing of, 192

- Solenoid, 125**
 — correction factor, 178
Solution, 61
Specific heat, 55, 57
 — resistance, 91, 92
Stability, magnetic, 37, 50
Stainless steel, 89
Stalloy, 27, 79, 80, 81, 125, 136, 199, 222, 223, 227
Standard cell, 142
 — condenser, 142
 — inductance, 149, 150
 — solenoid, 145, 148
Steel, 76, 81, 89
 — wire rope, 107, 108, 109
Steinmetz, C. P., 25, 229, 230
 — coefficient, 25, 229
 — law, 25
Step-by-step method, 99, 100, 163
Stray fields, 51
Stress, mechanical, 101, 107, 108, 109
Sulphur, 73, 111
Susceptibility, 13, 18, 120, 121, 122, 256, 257
Swedish iron, 29, 58, 89
Swinburne, J., 32
- Telephone receiver, 29**
Testing cutlery, 251
 — drills, 251
 — materials, American Society for, 243
 — steel rails, 248
 — wire ropes, 245
Theory, Evershed's, 34
 — Electron, 112
 — Ewing's, 29
Thermo-magnetic analysis, 254
Thompson, S. P., 25, 71
Torque, hysteresis, 253
Torsion, effect on magnetisation, 109, 110
- Total iron losses, 215, 227**
Transformer, hysteresis loss in, 233
Tungsten, 23, 61, 62
 — steel, 27, 46, 47, 49, 50, 63, 65, 69, 80, 89
Undamped deflection, 141
Unit magnetic pole, 9, 10
Units, electro-magnetic, 112, 113,
 — electro-static, 112, 115, 119
University of Illinois, 171,
Unsymmetrical cycle, 27,
- Vacuum melted iron, 26**
Variable frequency, separation of losses by, 221
 — form factor, separation of losses by, 224
Velocity, electron, 112
Villari reversal, 106, 108, 109
Viscosity, magnetic, 90, 91, 201
- Wall, T. F., 125, 192**
Watson, E. A., 47, 67
Wattmeter, iron losses by, 218, 220
Webb, C. E., 229
Weber, 29
Weiss, 116, 122
Wiedemann, 109
Wilson, E., 256
Wire Ropes, Magnetic Test for, 245
 — permeability, 108,
Wüst, 57, 63
- Y, self-demagnetising coefficient, 17**
Yensen, T. D., 26, 171, 183
- Zinc, 111**
Zonal harmonics, 180, 182, 183

A SELECTION OF BOOKS
FOR THE ELECTRICAL STUDENT
PUBLISHED BY
ERNEST BENN LIMITED

ELECTRICAL MEASURING INSTRUMENTS. By C. V. DRYSDALE, D.Sc., and A. C. JOLLEY, A.M.I.E.E.

PART I—COMMERCIAL INDICATING INSTRUMENTS: DYNAMOMETERS: HOT WIRE INSTRUMENTS: ELECTROSTATIC INSTRUMENTS. Crown 4to, 440 pages, 365 illustrations. Price 55/- net.

PART II—INDUCTION INSTRUMENTS, SUPPLY METERS AND AUXILIARY APPARATUS. Crown 4to, 476 pages, with 437 illustrations. Price 55/- net.

“So far as we are aware nothing has been published on electrical measuring instruments which is comparable with these two extensive and very informative books, and there is not much doubt, we think, that they will be regarded as standard works on the subject.”—ENGINEER.

“We have no hesitation in saying that in our opinion the book will be looked upon as a classic on the subject . . . a work of the utmost importance to all manufacturers of electrical instruments, to the actual users, such as central station engineers, and to every electrical engineering student.”—ELECTRICITY.

SMALL ELECTRIC GENERATING SETS. By W. WILSON, M.Sc., B.E., M.I.E.E., A.Am.I.E.E.

Deals with generating sets driven by oil and gas engines of a capacity ranging from about one-third to 10 kw., for the supply of electricity to private houses, farms, workshops and public buildings, to portable apparatus such as cinemas, X-ray installations, electric welders, etc., or for special purposes such as wireless equipment in unattended maritime stations and lifeboats.

“An exceedingly useful book for any person connected with the supply or fitting up of electrical installations.”—ELECTRICITY.

“A useful and welcome addition to technical literature . . . comprehensive and clear.”—ENGINEERING.

“The book can be recommended to all interested in the subject, which badly needed recognition as a special branch of electrical engineering.”—ELECTRICAL TIMES.

Medium 8vo. More than 60 illustrations. Price 18/- net.

RADIO ENGINEERING. By E. B. WEDMORE and J. H. REYNER, B.Sc., A.C.G.I.

RADIO CALCULATIONS AND MEASUREMENTS: Calculation of Inductance and Coil Design—Calculation of Mutual Inductance—Calculation of Capacity and Condenser Design—Capacity of Aerials—High-Frequency Resistance—Radio-Frequency Measurements. **TUNING AND RADIATION:** Laws of Oscillating Circuits—Tuning and Resonance—Damping and Decrement—Coupled Circuits—Aerials and their Characteristics—Radiation. **THERMIONIC VALVES—RADIO TRANSMITTERS—RADIO RECEIVING APPARATUS—DESIGNS OF MASTS AND AERIALS—Miscellaneous—TELEGRAPHY—TELEPHONY—MATHEMATICAL AND MISCELLANEOUS TABLES—LIST OF INTEGRALS—ELECTRICAL, MECHANICAL AND PHYSICAL TABLES, ETC., ETC.** Crown 8vo. 484 pages, 314 illustrations, and 111 tables. Price 15/- net.

“Mr. Wedmore and his collaborators are to be congratulated on the compilation of this important series of volumes. In them will be found an exhaustive collection of up-to-date information . . . the sections on Traction and Electrical Machinery contain a wealth of useful data regarding modern practice. . . . A feature of Volume II is the large amount of hitherto unpublished matter relating to the properties of insulating materials . . . a valuable and welcome addition to electrical engineering literature.”—
WORLD POWER.

THE ELECTRICAL TRADES DIRECTORY AND HANDBOOK

This unique publication is the only complete Trades Directory of the Electrical Industry, and acts as a medium between makers and buyers. It contains information indispensable to Manufacturers, Contractors, Engineers, Railway and Tramway Officials and Undertakings, Telegraph and Telephone Engineers, Radio Engineers and all Technical Colleges and Institutions. It is now in its 44th year, and is established as the standard reference book for the whole of the Electrical Engineering and Allied Trades. Published annually on January 30.

1927 edition, containing over 1400 pages with 50,000 entries. Price 25/- net.

** Complete Lists will gladly be sent upon application.*

ERNEST BENN LIMITED
BOUVERIE HOUSE
FLEET STREET
E. C. 4

Eclipse

REGISTERED MARK

JAMES NEILL & CO (SHEFFIELD) LTD
STEEL MANUFACTURERS
NAPIER ST SHEFFIELD

PERMANENT MAGNETS

FOR — — —
MAGNETOS
MEASURING
INSTRUMENTS
LOUD SPEAKERS
TELEPHONES
DYNAMOS
FAN MOTORS
ETC., ETC..

BH_{max}
250,000 — 950,000
ACCORDING
TO QUALITY

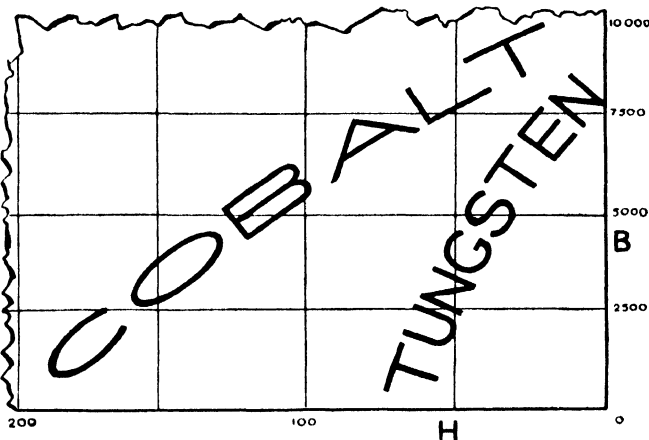

THE STANDARD REFERENCE BOOKS

Electrical Engineers' Data Books

EDITED BY R. B. WEDMORE, M.I.E.E., & COMPILED BY
D. V. ONSLOW, A.M.I.E.E. & J. W. REYMER, B.Sc.

VOLUME ONE

LIGHTING, TRACTION & POWER DISTRIBUTION

VOLUME TWO

MANUFACTURE, DESIGN & LABORATORY WORK

PRICE 15s. EACH VOLUME

"No engineer desiring to be in possession of the results of modern research can afford to be without these invaluable books." — "ELECTRICITY"

"An immense amount of care and labour has been devoted to their preparation, and they are correspondingly useful to the purchaser." — "ELECTRICAL REVIEW"

ERNEST BENN LTD., 154 FLEET STREET, LONDON, E.C.4

