

UNIVERSAL  
LIBRARY

**OU\_164040**

UNIVERSAL  
LIBRARY



**OSMANIA UNIVERSITY LIBRARY**

Call No. 537.52

Accession No.

Author C. B. K.

Title

This book should be returned on or before the date last marked below

---



# X-Rays and Electrons

*An Outline of Recent X-Ray Theory*

*By*

ARTHUR H. COMPTON, PH.D.

*Professor of Physics in the University of Chicago*

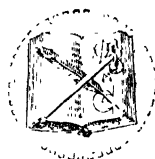

NEW YORK  
D. VAN NOSTRAND COMPANY  
EIGHT WARREN STREET  
1926

COPYRIGHT, 1926,

BY

D. VAN NOSTRAND COMPANY

---

*All rights reserved, including that of translation  
into the Scandinavian and other foreign languages*

*Printed in the U. S. A.*

## PREFACE

---

THOSE who have been following the recent developments of physics would probably agree that its two most vital problems are the structure of matter and the nature of radiation. It is true that much has been done toward the solution of both of these problems. Matter, we find, is built up of molecules, these of atoms, and the atoms in turn of electrons. We now have before us the problem of finding how an atom can be formed out of a few positive and negative electrons. X-ray studies have enabled us to count the number of electrons in the various atoms, and have informed us regarding their distribution and the forces that hold them in position. Perhaps no single field of investigation has contributed more to our knowledge of atomic structure than has the study of X-rays.

This is in part because of the very short wave-length of X-rays. The theoretical limit of the microscope, using ordinary light, is such that we cannot hope by its help to determine the shape of a body much smaller than a wave-length of light, .0005 mm. If an X-ray microscope could be employed, this limit might be reduced by a factor of ten thousand, and we should then be working on a sub-atomic scale. Though such an instrument does not exist, interference effects are measurable due to X-rays traversing groups of atoms, and from them we are able to interpret the structure of the matter giving rise to the diffraction almost as definitely as if we were employing an X-ray microscope.

Similarly in the field of radiation it is the high frequency which gives significance to experiments with X-rays. Since the magnitude of the energy quantum is proportional to the

frequency, quantum phenomena such as the photoelectric effect, which can be studied only statistically when light is used, can with X-rays be considered as individual events. That is, the effects of individual X-ray quanta can be observed and measured. It is perhaps for this reason that X-ray investigations have supplied us with our best determinations of Planck's fundamental constant  $h$ . It is also the comparatively large energy and momentum associated with the quantum of X-rays which have made possible the recent experiments on the change of wave-length of scattered X-rays and allied effects, pointing so definitely to a quantum structure of radiation itself.

This book has grown from lectures on X-rays which I have given at the University of California and the University of Chicago during the last five years. Though I have tried to cover the whole field of the physics of X-rays with some completeness, those aspects have naturally been treated in greater detail which are most closely allied with my own researches. Such emphasis is perhaps the more justified by the recent appearance of a new edition of the Braggs' notable book *X-rays and Crystal Structure*, together with treatises by Wyckoff, Rinne, Ewald and others covering about the same field, and Siegbahn's excellent account of *The Spectroscopy of X-rays*. In the present volume only an introduction to the problems of crystal structure and X-ray spectroscopy has been given. Kaye and de Broglie in their books on *X-rays* have described in some detail the experimental aspects of the subject. It is rather with the interpretation of the properties of X-rays in terms of the interaction between radiation and electrons that the present work deals. I have been chiefly concerned with the information X-ray studies have afforded regarding the structure of the atom and the nature of the X-rays themselves.

Since Barkla's discovery of the polarization of X-rays, it has been generally recognized that the study of X-rays is a branch of optics. The first half of the present book treats the subject from this standpoint. It has been of great interest to

me to see how, while the manuscript has been in preparation, discoveries of the refraction and total reflection of X-rays and of their diffraction by slits and ruled gratings have extended all branches of optics to the very high frequencies of X-rays. In view of the failure of the classical electrodynamics to account for the radiation of light, it is perhaps not surprising that it should also fail to account completely for the origin of X-rays. It is however a matter of prime importance that the laws of interference and diffraction, which have been found flawless in ordinary optics, are found to fail when X-rays and  $\gamma$ -rays are used. This observation, resulting from the classical treatment of X-ray scattering given in Chapter III, is the natural (as well as historic) introduction to the quantum treatment of the scattering problem given in Chapter IX.

The X-rays thus constitute a powerful tool for solving physical problems. In order to give a correct impression of the methods and reasoning employed in solving these problems, it will be necessary to deal with many parts of the subject from a mathematical standpoint. It is by these mathematical processes that the most important results are often first obtained, and it would be unfair to give the impression that they can be secured in any other way. At the same time I have tried to keep uppermost the physical concepts, since it is these which point out the path which the mathematics must follow.

I wish to thank Professor P. A. Ross for his generous assistance in reading the proof, without which the publication of the book would have been considerably delayed.

A. H. C.

CHICAGO,  
May 24, 1926.



# CONTENTS

## CHAPTER I

### THE DISCOVERY AND PROPERTIES OF X-RAYS

ART.	PAGE
1. Roentgen's Early Experiments . . . . .	I
2. Ionization Produced by X-rays . . . . .	4
3. Absorption of X-rays . . . . .	6
4. Secondary Rays Produced by X-rays . . . . .	10
Scattered Rays . . . . .	12
Fluorescent Rays . . . . .	12
Photoelectrons Ejected by X-rays . . . . .	13
5. Polarization of X-rays . . . . .	15
6. Diffraction and Interference of X-rays . . . . .	16
Diffraction by Slits . . . . .	17
Absolute Wave-length Measurements with Ruled Gratings . . . . .	17
Diffraction of X-rays by Crystals. . . . .	18
7. X-ray Spectra . . . . .	25
The Continuous X-ray Spectrum . . . . .	27
8. Bohr's Theory of Spectra . . . . .	29
9. Refraction of X-rays . . . . .	35

## X-RAYS AND ELECTRODYNAMICS

### CHAPTER II

#### THE ELECTROMAGNETIC THEORY OF THE PRODUCTION OF X-RAYS

10. <i>Electromagnetic Pulses</i> . . . . .	38
11. Field Due to an Electron in Slow, Uniform Motion . . . . .	38
12. Field Due to Accelerated, Slowly Moving, Electron. . . . .	40
Energy and Intensity of Radiation . . . . .	42
13. Intensity of X-rays on the Pulse Theory . . . . .	43
Relative Intensity in Different Directions . . . . .	45
Relative Frequency in Different Directions . . . . .	46
Polarization of Primary X-rays . . . . .	46
Efficiency of Production of X-rays . . . . .	48
14. Difficulties with the Pulse Hypothesis . . . . .	50
Sharp Short Wave-length Limit Demands Oscillation about Atomic Centers . . . . .	51
Doppler Effects Exclude Oscillation about Atomic Centers . . . . .	52

ART.	PAGE
15. <i>Characteristic Radiations Producing Line Spectra</i> . . . . .	52
16. Energy and Intensity of Long Wave Trains . . . . .	53
17. Width of Spectrum Lines Due to Damping of Electron's Motion by Radiation . . . . .	54
18. Minimum Wave-length of a Spectral Line . . . . .	56

## CHAPTER III

## THE SCATTERING OF X-RAYS

19. <i>Thomson's Theory of Scattering by Independent Electrons</i> . . . . .	58
<i>Measurements of the Total Scattered X-rays</i> . . . . .	60
20. Determination of the Number of Electrons per Atom . . . . .	61
21. Hard X-rays Scattered Less than Predicted . . . . .	62
22. Interference Effects with Heavy Scattering Elements . . . . .	64
<i>Relative Scattering at Different Angles</i> . . . . .	65
23. Approximate Validity of $(1 + \cos^2 \phi)$ Rule for Soft X-rays . . . . .	65
24. Departures from Theory for Hard X-rays . . . . .	67
25. Polarization of Scattered X-rays . . . . .	68
26. Wave-length of Scattered X-rays . . . . .	69
Modified and Unmodified Rays . . . . .	70
<i>Scattering by Groups of Electrons.</i> . . . .	72
27. Theoretical Formulas of Debye and Others . . . . .	72
28. Experiments Showing Interference Effects . . . . .	75
29. Empirical Electron Distributions . . . . .	77
30. Scattering by Any Grouping of Electrons . . . . .	79
31. A Method of Comparing Wave-lengths . . . . .	80
32. A Failure of the Wave Theory of Interference . . . . .	82
33. <i>Attempts to Account for the Small Scattering of Hard X-rays</i> . . . . .	83
34. Constraining and Damping of Electrons' Motions . . . . .	84
35. The Complex Electron . . . . .	87
36. The Large Electron . . . . .	88
37. Summary . . . . .	89

## CHAPTER IV

## X-RAY REFLECTION AND CRYSTAL STRUCTURE

38. <i>Laue's Discovery and its Consequences</i> . . . . .	90
39. <i>The Space Lattice</i> . . . . .	91
40. Cubic Lattices . . . . .	92
Miller Indices . . . . .	94
41. <i>Crystal Structure by X-ray Reflection from Crystal Faces</i> . . . . .	95
Structure of Rock-salt and Sylvine . . . . .	97
42. Confirmation by Measurement of X-ray Wave-lengths. . . . .	99
43. Reflection Method Using Known Wave-length . . . . .	100
Structure of Diamond . . . . .	100
44. <i>Powdered Crystal Method of X-ray Crystal Analysis</i> . . . . .	102
45. Structure of Molybdenum Crystals . . . . .	107

# CONTENTS

ART.	PAGE
46. <i>Method of the Laue Spots</i> . . . . .	110
47. Gnomonic Projection . . . . .	110
48. Structure of Magnesium Oxide . . . . .	113
49. Crystal Structures of the Solid Elements . . . . .	115

## CHAPTER V

### INTENSITY OF THE REFLECTION OF X-RAYS FROM CRYSTALS

#### INTRODUCTION

50. Reflecting Power as a Function of Electron Distribution . . . . .	117
---	-----

#### THEORY OF THE INTENSITY OF CRYSTALLINE REFLECTION

51. Perfect and Irregular Crystals . . . . .	118
52. Diffraction by a Very Small Crystal . . . . .	121
53. Diffraction by an Irregular Crystal . . . . .	126
54. Case of Transmission of Diffracted Rays . . . . .	126
55. Case of Reflection of Diffracted Rays . . . . .	127
56. Diffraction by Powdered Crystals . . . . .	129

#### MEASUREMENTS OF THE INTENSITY OF DIFFRACTED X-RAYS

57. Measurements on Powdered Crystals . . . . .	132
58. Measurements on Single Crystals . . . . .	133
59. Effects of Extinction . . . . .	134
60. Determination of the Extinction Coefficient . . . . .	135
61. Experimental Values of the Structure Factor . . . . .	137
62. <i>Reflection by Perfect Crystals and the Effect of Extinction</i> . . . . .	139
63. Theory of Reflection from a Perfect Crystal . . . . .	140
64. Comparison with Experiment . . . . .	142
65. Effect of Extinction in Real Crystals . . . . .	143
Primary and Secondary Extinction . . . . .	144
66. Criteria for Detecting Primary Extinction . . . . .	146
67. <i>Determination of Electron Distributions from a Knowledge of the Structure Factor</i> . . . . .	148
68. Method of Trial . . . . .	148
69. Use of Empirical Reflection Formula . . . . .	149
70. Method of Fourier Series . . . . .	151
71. Electron Density at Any Height above the Middle of an Atomic Layer . . . . .	152
72. Electron Density at Any Point in the Space Lattice . . . . .	159
73. Radial Electron Distribution in Atoms . . . . .	161
74. Electron Distributions in Sodium, Chlorine and Aluminum . . . . .	165
Discussion of the Reliability of the Method . . . . .	168
75. <i>Effect of Temperature on X-ray Reflection</i> . . . . .	169
76. X-rays Diffusely Scattered by a Crystal . . . . .	170
77. <i>Effect of Magnetization on X-ray Reflection</i> . . . . .	173

## CHAPTER VI

## THE ABSORPTION OF X-RAYS

ART.	PAGE
78. <i>Total and True Absorption</i> . . . . .	175
79. <i>The Measurement of Absorption Coefficients</i> . . . . .	177
80. Tables of Absorption Coefficients . . . . .	179
81. <i>Critical Absorption Wave-lengths</i> . . . . .	186
82. Table of Critical Absorption Wave-lengths . . . . .	189
83. <i>Empirical Absorption Formulas</i> . . . . .	189
84. Owen's Law . . . . .	192
85. Absorption Due to Scattering . . . . .	174
<i>Electromagnetic Theory of True Absorption</i> . . . . .	195
86. Pulse Theory . . . . .	195
87. Absorption of Long Trains of Waves . . . . .	198
88. Experimental Tests . . . . .	203

## CHAPTER VII

## THE REFRACTION OF X-RAYS

89. <i>Introduction</i> . . . . .	205
90. <i>Calculation of the Refractive Index</i> . . . . .	206
91. Significance of a Refractive Index Less than Unity . . . . .	210
<i>Experimental Determinations of the Refractive Index</i> . . . . .	211
92. Deviations from Bragg's Law . . . . .	211
93. Use of the Crystal Wedge . . . . .	214
94. Total Reflection of X-rays . . . . .	215
95. Refraction by Means of a Prism . . . . .	217
96. Table of Refractive Indices for X-rays . . . . .	218
97. <i>Significance of the Values of the Refractive Index</i> . . . . .	218

## X-RAYS AND QUANTUM THEORY

## CHAPTER VIII

## THE PHOTOELECTRIC EFFECT WITH X-RAYS

98. <i>The Origin of the Quantum Theory</i> . . . . .	221
99. Planck's Quantum Hypothesis . . . . .	221
100. Einstein's Suggestion of Radiation Quanta . . . . .	222
Einstein's Photoelectric Equation . . . . .	223
101. <i>Beta Rays Excited by X-rays</i> . . . . .	224
102. Methods of Experimental Investigation . . . . .	224
103. Photoelectrons and Recoil Electrons. . . . .	227
104. <i>Speed of the Photoelectrons</i> . . . . .	230
105. Determination of Energy Levels . . . . .	232
106. Wave-lengths of X-rays . . . . .	233
107. Compound Photoelectric Effect . . . . .	233
108. <i>Spatial Distribution of the Photoelectrons</i> . . . . .	235
<i>How are Photoelectrons Produced?</i> . . . . .	238

# CONTENTS

xiii

ART.	PAGE
109. Inadequacy of Electromagnetic Waves . . . . .	238
110. <i>Photoelectrons and Radiation Quanta</i> . . . . .	240
Theory for Electrons Initially at Rest . . . . .	240
111. Experimental Test . . . . .	246
Theory for Electrons Initially in Motion . . . . .	246
112. 1. Bubb's Theory . . . . .	246
113. 2. Theory of Auger and Perrin . . . . .	249
114. Significance of the Experiments . . . . .	251
115. <i>Number of Photoelectrons</i> . . . . .	253
<i>Passage of Photoelectrons through Matter</i> . . . . .	254
116. Range . . . . .	254
117. Ionization Due to Beta Rays . . . . .	257
118. Form of Beta Ray Tracks . . . . .	258

## CHAPTER IX

### QUANTUM THEORY OF X-RAY SCATTERING

119. <i>A. Scattered X-rays as Directed Quanta Instead of Waves</i> . . . . .	260
<i>The Change of Wave-length of Scattered X-rays</i> . . . . .	260
120. Early Experiments . . . . .	260
121. Theory of Quanta Scattered by Free Electrons . . . . .	265
122. Measurements of the Change of Wave-length Accompanying the Scattering of X-rays . . . . .	268
123. The Unmodified Line . . . . .	272
124. <i>Recoil Electrons</i> . . . . .	273
125. <i>Directed Quanta vs. Spreading Waves</i> . . . . .	276
126. Waves vs. Conservation of Energy and Momentum . . . . .	277
127. Scattering of Quanta by Individual Electrons . . . . .	279
128. Directed Quanta of Scattered X-rays . . . . .	281
129. <i>B. Quanta Scattered by Bound Electrons</i> . . . . .	285
130. Limits Imposed by Conservation of Energy . . . . .	286
The Mechanism of Interaction . . . . .	287
131. Assumption of Instantaneous Action on Electron . . . . .	287
132. Theory for Circular Orbits . . . . .	289
133. Case of Elliptic Orbits . . . . .	291
134. Partial Experimental Confirmation . . . . .	293
135. <i>C. Intensity of the Scattered X-rays</i> . . . . .	296
136. Limiting Formulas Suggested by Correspondence Principle . . . . .	296
137. Proposed Intensity Formulas . . . . .	297
138. Experimental Tests . . . . .	306
139. True Scattering and True Absorption Associated with Scattering . . . . .	309

## CHAPTER X

### QUANTUM THEORY OF X-RAY DIFFRACTION

140. The Quantum Conditions . . . . .	315
141. Bohr's Frequency Condition . . . . .	316

ART.	PAGE
142. Diffraction by a Crystal . . . . .	317
143. Diffraction by an Infinite Simple Cubic Crystal . . . . .	318
144. Other Diffraction Problems . . . . .	320
145. What is the "Frequency" of a Quantum? . . . . .	321

## CHAPTER XI

## X-RAY SPECTRA

146. X-ray Spectra as a Test of Bohr's Theory . . . . .	324
Measurements of X-ray Wave-length . . . . .	325
147. The Grating. . . . .	325
148. Typical X-ray Spectra. . . . .	328
149. Classification of X-ray Spectra . . . . .	330
150. Energy Level Diagrams . . . . .	332
151. The Selection Rule . . . . .	333
152. Regular and Irregular Doublets . . . . .	334
153. Interpretation of the X-Ray Spectra . . . . .	335
154. Sommerfeld's Theory of the Origin of the Doublets . . . . .	335
155. Difficulties with Sommerfeld's theory . . . . .	341
156. Electron Distributions Determined by X-ray Spectra . . . . .	343

## CHAPTER XII

## QUANTUM THEORY OF X-RAY PRODUCTION AND ABSORPTION

157. Relation between the Emission and Absorption of X-rays . . . . .	348
158. L. de Broglie's Theory of X-ray Absorption . . . . .	349
159. Kramers' Theory of Emission and Absorption . . . . .	351
160. The Intensity of the Radiation . . . . .	352
161. The Absorption Coefficient . . . . .	355
162. Emission of X-rays as Directed Quanta . . . . .	357
163. Frequency of the Emitted Quanta . . . . .	360
164. Polarization . . . . .	362

## APPENDICES

## APPENDIX I

RADIATION FROM AN ELECTRON MOVING WITH A VELOCITY APPROACHING  
THAT OF LIGHT

A. The Lorentz Transformation Equations	
1. Einstein's Derivation of the Fundamental Transformations . . . . .	365
2. Displacement, Velocity and Acceleration . . . . .	367
3. The Electromagnetic Field . . . . .	370
4. Variation of Mass with Velocity . . . . .	374
B. Field Due to Electron Accelerated in Direction of Motion . . . . .	378

# CONTENTS

xv

## APPENDIX II

	PAGE
EXPRESSION OF A PULSE AS A FOURIER INTEGRAL . . .	381

## APPENDIX III

ATOMIC AND ELECTRONIC CONSTANTS. . . . .	383
--	-----

## APPENDIX IV

SCATTERING BY A PAIR OF ELECTRONS . . . . .	384
---	-----

## APPENDIX V

THE WAVE-LENGTH OF GAMMA RAYS, FROM RADIUM C . . .	389
--	-----

## APPENDIX VI

CALCULATION OF THE CHANGE OF WAVE-LENGTH AND THE ENERGY OF RECOIL	393
---	-----

## APPENDIX VII

WAVE-LENGTHS OF X-RAY SPECTRUM LINES . . . . .	396
--	-----

INDEX .....	399
-------------	-----



## CHAPTER I

### THE DISCOVERY AND PROPERTIES OF X-RAYS

#### 1. *Roentgen's Early Experiments*

It was in the course of a systematic attempt to see if any radiation could be produced which would traverse matter opaque to ordinary light that Roentgen discovered the X-rays.<sup>1</sup> He was passing an electric discharge through a highly evacuated tube, and had been studying the ultra-violet light produced, using for its detection the fluorescence of crystals of platinum-barium-cyanide spread on a paper screen. Having covered his discharge tube completely with opaque paper, he found that the screen continued to fluoresce. From the fact that heavy objects placed between the tube and the crystal stopped the fluorescence, it was obvious that the effect was due to some type of radiation sent out by the discharge tube. This radiation was named by Roentgen "X-rays," indicating their unknown nature. The discovery of these rays attracted great interest, and experimenters the world over began to study their characteristics.

Besides producing fluorescence in certain salts, these rays were found to affect a photographic plate and to ionize gases, so that three methods, the visual, the photographic and the electrical, could be employed in their examination. It was shown also by Brandes and Dorn that X-rays produce an effect, though a small one, directly upon the retina, giving rise to a very faint illumination of the whole field of view. The

<sup>1</sup> W. C. Roentgen, *Sitzungsber. der Würzburger Physik-Medic. Gesellsch.* Jahrg. 1895, reprinted in *Ann. der Phys.* 64, 1 (1898). Translation by A. Stanton in *Science*, 3, 227 (1896).

rays were not subject to refraction nor reflection like ordinary light, nor were they bent by a magnetic field as were cathode rays. They were, however, diffusely scattered by all substances, and were partially absorbed by matter of all kinds. This absorption was much stronger by elements of high than by elements of low atomic weight.

The tube with which Roentgen made his original discovery was of the type shown in Fig. 1. The tube was well evacuated with a mercury pump until a potential difference of about 40,000 volts was required to produce a discharge. The cathode

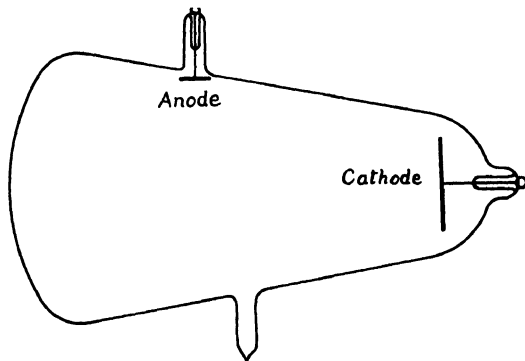

FIG. 1.

rays, shot perpendicularly from the cathode's surface, then struck the broad end of the tube, producing a vivid fluorescence and at the same time giving rise to the X-rays. It was soon found that any substance struck by the cathode rays emitted X-rays, but that these rays were more intense from a target of high atomic weight. In order to obtain a point source of rays, the cathode was made concave, so that the cathode rays were focused on a small spot at target. This modification made necessary the use of a target of high melting point, in order to avoid damage due to the heat developed at the focus of the cathode rays. Thus the type of tube shown in Fig. 2 was soon developed, which, with minor modifications, is still widely used. It is a characteristic of the low pressure discharge tube that the

potential difference between the anode and the cathode remains practically constant for large variations in the current through the tube. In order to change the voltage across a tube of this type, therefore, it is necessary to alter the pressure of the

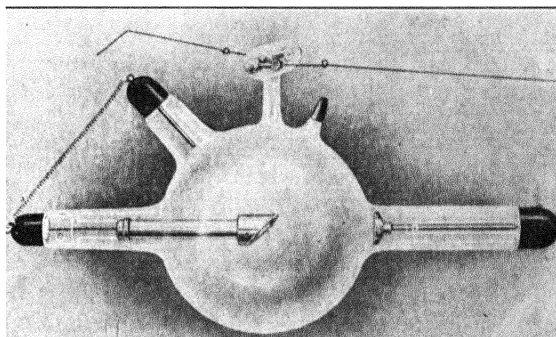

FIG. 2.

gas in the tube. In many of the tubes now in use, such changes can be effected by various ingenious devices. A tube which avoids this complication has been invented by Coolidge.<sup>1</sup> In this tube the cathode consists of a flat spiral of tungsten

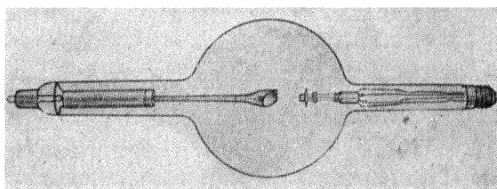

FIG. 3.

wire which is heated by a battery current to such a temperature that it emits thermoelectrons. The tube is evacuated until there is no appreciable amount of gas remaining, so that

<sup>1</sup> W. D. Coolidge; *Phys. Rev.* 2, 409 (1913). See also J. E. Lilienfeld and W. J. Rosenthal, *Forts. auf d. Geb. d. Roentgenstrahlen*, 18, 256 (1912).

all of the current through the tube is carried by the thermo-electrons. Thus the current through the tube is determined almost completely by the temperature of the filament, and the potential difference between the cathode and anode of the tube can be altered at will.

## 2. *Ionization Produced by X-rays*

The manner in which ionization is produced by X-rays is elegantly shown by C. T. R. Wilson's remarkable photographs of the passage of X-rays through air. Without entering into the details of the methods,<sup>1</sup> it will suffice for the present to point out that the curved lines shown in Fig. 4 consist of series of water drops, which have been illuminated by an intense spark. Each drop has formed upon a separate ion as a nucleus. In this photograph, the X-rays passed from left to right through the middle of the picture. The part of the air exposed to the X-rays differs from the rest of the air only in the fact that it is this region in which the curved lines originate. In other words, the action of the X-rays is to eject from the air high speed particles ( $\beta$ -rays) which break into ions the molecules through which they pass. Thus the process of ionization is to a large extent an indirect one. Whereas in the present photograph the X-rays have ejected about twenty  $\beta$ -rays, these particles, while tearing their way through the air, have produced thousands of ions.

It is the ions thus formed which give to air and other gases their electrical conductivity when exposed to X-rays. The number of high speed  $\beta$ -particles, and hence also the total number of ions produced, is found to be proportional to the energy of the X-rays which traverse the air. A measurement of this ionization by means of an electroscope or an ionization chamber connected with an electrometer thus affords a convenient method of measuring the intensity of an X-ray beam.

<sup>1</sup> C. T. R. Wilson, Proc. Roy. Soc. A. **87**, 277 (1912).

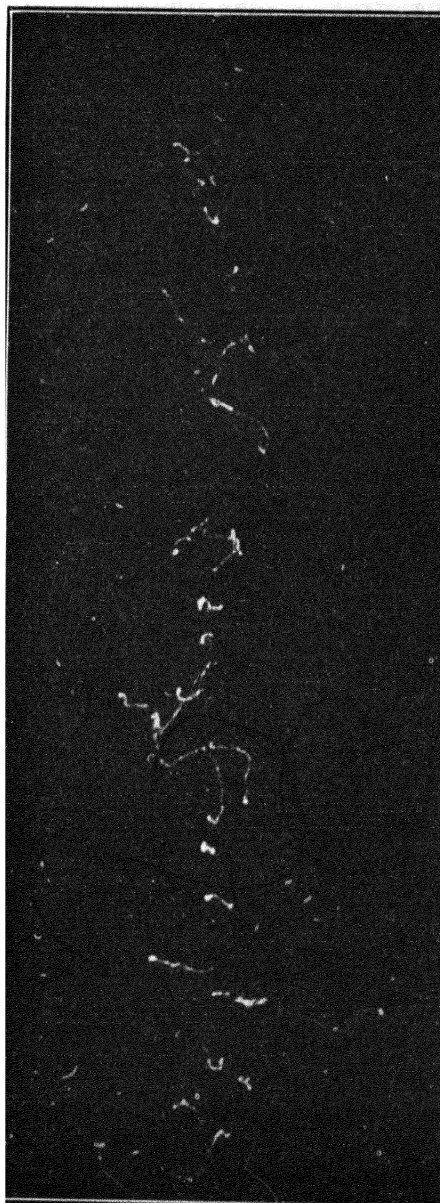

FIG. 4

### 3. Absorption of X-rays

We have noticed that X-rays are much more strongly absorbed by some substances than by others. The reduction in intensity of X-rays as they traverse matter can be studied by the use of such apparatus as that shown in Fig. 5. Here the X-rays are produced in a tube  $S$ , and are measured by means of an ionization chamber  $I$  which is connected to some form of electrometer  $E$ . The ionization produced by the X-rays permits the batteries to send a current through the chamber, which is measured by the electrometer. If the potential of the

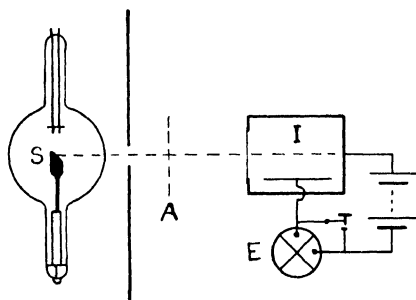

FIG. 5.

batteries is sufficiently great, practically all of the ions reach the electrodes before they recombine, and this ionization current is proportional to the intensity of the X-rays. Thus the ratio of the current with an absorbing screen at  $A$  to the current without it, measures the relative intensity of the X-ray beam in the two cases.

In order to speak of the absorption quantitatively, it is convenient to define what is known as the “*absorption coefficient*.” Let us suppose that the fraction  $dI/I$  of the intensity  $I$  of a beam of X-rays absorbed as they pass through a thin layer of matter is proportional to the thickness  $dx$  of this layer. Then

$$\frac{dI}{I} = -\mu dx,$$

where  $\mu$  is the constant of proportionality, and the negative sign indicates a *decrease* in intensity. On integration,

$$\log I = - \mu x + \log I_0,$$

taking  $\log I_0$  as the constant of integration. This may be written,

$$\log \left( \frac{I}{I_0} \right) = - \mu x,$$

or

$$I = I_0 e^{-\mu x}. \quad (1.01)$$

It is clear from the latter expression that  $I_0$  represents the intensity of the rays when  $x$  is zero, whereas  $I$  is the intensity after traversing a layer of matter of thickness  $x$ . The quantity  $\mu$  is the *absorption coefficient*, or *linear* absorption coefficient, and is defined by the expression

$$\mu \equiv - dI/Idx,$$

that is, it is the fractional decrease in intensity per unit path through the absorbing medium.

If we consider a beam of X-rays 1 cm.<sup>2</sup> in cross section, an equivalent definition of the linear absorption coefficient is the fraction of the energy of this beam which is absorbed per cm.<sup>3</sup> of the matter traversed. For many purposes, instead of the absorption per unit volume, we desire to know the fraction of the energy absorbed when a beam of unit cross section traverses unit mass of the material. This fraction is  $\mu_m = \mu/\rho$ , where  $\rho$  is the density of the material, and is called *the mass absorption coefficient*. The reason for the importance of this quantity is that it is characteristic of the absorbing substance, whereas the absorption per unit volume coefficient  $\mu$  is not. Thus the linear absorption coefficient of a given beam of X-rays is much greater in water than in steam, whereas the mass absorption coefficient is the same in both. For in the latter case the amount of matter, 1 gram, traversed by an X-ray beam of unit cross section is independent of the density.

For purposes of calculation, we often wish to compare the amount of energy absorbed by an atom of each of several different elements. Since  $\mu$  is the fraction of a beam of X-rays of unit cross section which is absorbed by unit volume of matter, the fraction of this beam absorbed by an individual atom is  $\mu_a = \mu/n$ , where  $n$  is the number of atoms per cm.<sup>3</sup> This quantity is called the "*atomic absorption coefficient*."

The remark has just been made that the mass absorption coefficient of water is the same whether in the form of liquid or of gas. This is an example of the experimental fact that the mass absorption coefficient of a substance for X-rays is independent of its physical state.<sup>1</sup> It is also found that the fraction of the energy absorbed per atom or per unit mass of an element is independent of its state of chemical combination. This has been tested, for example, in the recent experiments of Olson, Dershem and Storch. From theoretical considerations it is clear that differences due to chemical condition should be more prominent for the lighter elements, for in these elements there is a relatively larger number of valence electrons. Their most significant experiments are thus with carbon and oxygen. The results are summarized in the following table:

TABLE I-1  
MASS ABSORPTION COEFFICIENTS OF X-RAYS OF WAVE-LENGTH,  $10^{-8}$  CM.

Element	Form	$\mu_m$	Observer
Carbon.....	Graphite	1.21	Hewlett *
	Aliphatic compounds	1.18	O. D. & S. †
	Aromatic compounds	1.21	O. D. & S.
Oxygen.....	Liquid	2.81	Hewlett
	Organic compounds	2.94	O. D. & S.

\* C. W. Hewlett, Phys. Rev. 17, 284 (1921).

† A. R. Olsen, Elmer Dershem and H. H. Storch, Phys. Rev. 21, 30 (1923). Cf. also E. G. Taylor, Phys. Rev. 20 (Dec., 1922).

<sup>1</sup>This is not quite true. Recent experiments by H. S. Read (Phys. Rev. Apr., 1926) have seemed to show a small variation of  $\mu_m$  with temperature, and J. A. Bearden (Phys. Rev. June, 1926) has called attention to minor variations of  $\mu_m$  with the state of crystallization that are doubtless connected with the reflection from the crystal faces.

The small differences which remain are probably within the experimental error.

This independence of the mass and atomic absorption coefficients from the physical and chemical state of an element sharply distinguishes X-rays from ordinary light. Thus, while liquid or solid mercury is opaque to light, its vapor is almost perfectly transparent. Carbon in the form of diamond is highly transparent, while in the form of graphite it absorbs light very strongly; but the mass absorption of both forms for X-rays is the same.

The absorption coefficient of the total radiation from an X-ray tube is found to depend chiefly upon two factors, the potential applied to the X-ray tube, and the atomic number of the absorbing screen. The penetration or "hardness" of the X-rays increases very rapidly as the voltage rises, the absorption coefficient in most substances varying inversely as the potential raised to some power between 2 and 3. Using the same beam of X-rays, the penetration decreases rapidly as atomic weight, or more exactly the atomic number, of the absorbing material increases. There are, however, certain irregularities in the curve relating the atomic number and the absorption coefficients, which later will be considered in detail.

In deriving our expression 1.01 for the intensity of the X-ray beam after it has traversed a layer of matter, we assumed that the quantity  $\mu$  was a constant for all values of  $x$ . Experiment shows that this assumption is valid only under very special conditions. When the direct radiation from an X-ray tube is studied, the first layers of the absorption screen remove a large fraction of the less penetrating, or "soft" radiations, so that only the more penetrating, or "hard" portions reach the final layers. The effective value of  $\mu$  is accordingly greater for the rays which enter an absorbing screen than for those that leave. When, however, a ray is used which is all of the same wave-length, its absorption coefficient remains unchanged as it traverses matter. Such a ray is said to be *homogeneous*.

#### 4. Secondary Rays Produced by X-rays

When X-rays traverse matter, the matter becomes a source of secondary X-rays.<sup>1</sup> The intensity of the secondary rays is usually very small compared with the intensity of the primary radiation falling on the matter. This is necessarily the case. For in the first place, only a part of the energy of the primary beam which is dissipated in the radiator reappears as X-rays, and in the second place the reradiated X-rays spread in all directions, so that their intensity in any one direction is small.

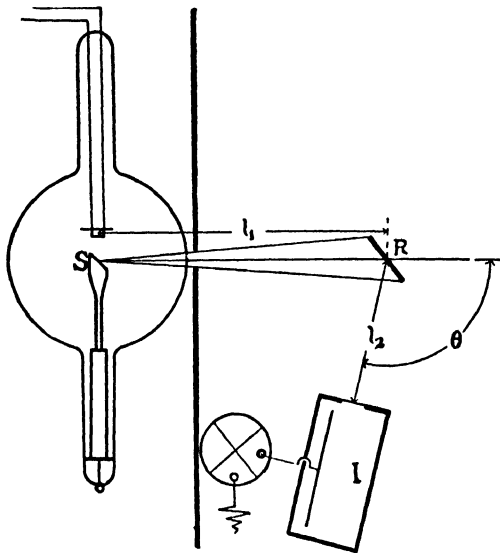

FIG. 6.

The usual method of investigating secondary X-rays may be explained by reference to Fig. 6. Radiation from the target  $S$  of an X-ray tube, or from some other source of X-rays, is allowed to traverse a radiator  $R$ . This radiator is then found to emit radiation in all directions. These rays may be investigated by means of an ionization chamber  $I$  which is carefully screened from the primary beam.

<sup>1</sup> Cf. M. I. Pupin, *Science*, 3, 538 (1896).

If the radiator consists of a plate of matter so thin that the X-rays are not appreciably diminished in intensity on traversing it, the intensity  $I$  of the secondary beam as it enters the ionization chamber may be written as

$$I_r = r_\theta IV/l_2^2,$$

where  $I$  is the intensity of the primary beam at  $R$ ,  $V$  is the volume of the radiator,  $l_2$  is the distance from the radiator to the ionization chamber, and  $r_\theta$  is a constant of proportionality which may be called the "radiating coefficient for the angle  $\theta$ ." Experiment shows that this coefficient is a function of the wave-length or hardness of the incident rays, their state of polarization, the composition and physical state of the radiator, and the angle  $\theta$ .

Scattered and Fluorescent X-Rays.—It is found that many materials when used as radiators give rise to two distinct types of secondary radiations. One of these, known as "scattered" rays, is very nearly identical in absorption coefficient or wave-length with the primary beam. The other type, known as the "fluorescent" rays, is distinctly less penetrating, or of greater wave-length, than the primary X-rays. Scattered rays seem to be primary rays which have merely had their direction altered by the matter through which they pass. The fluorescent rays, on the other hand, are characteristic of the radiator, and do not change in character with change in wave-length of the primary beam as long as this beam is of sufficiently short wave-length to excite the fluorescence. Refined experiments show that the scattered rays are also somewhat less penetrating than the primary rays which produce them, though this change in hardness or wave-length is usually small compared with the change which occurs when fluorescent radiation is excited. The two types of radiation can however be distinguished by the fact that, whereas the wave-length of the fluorescent rays is characteristic of the radiator and independent of the wave-length of the primary rays, the wave-length of the scattered rays depends upon that of the primary beam and is nearly independent of the radiator.

*The origin of the scattered ray* becomes at once apparent if we think of the primary X-ray as an electromagnetic wave. When such a wave strikes an electron, the electron is accelerated by the electric field. But, according to electrodynamics, an accelerated electric charge must radiate. Consequently the electron radiates energy due to its forced oscillations under the action of the primary beam. Since these forced oscillations are of the same frequency as the incident wave, the rays produced by these oscillations must also be of the same frequency. The fact that experiment shows a slightly different frequency between the primary and the scattered ray indicates that this explanation must be somewhat modified. This will be done (Chapter IX) when we introduce the quantum theory of X-ray scattering.

*The fluorescent ray originates* in the ionization and subsequent recombination of the atoms of the radiator. As we have seen, when the X-rays traverse matter, a part of their energy is spent in ejecting  $\beta$ -rays, or electrons, from some of the atoms. The remainder of the atom is in an ionized condition, and when it draws to itself another electron to regain its normal state, energy is liberated which reappears as the fluorescent X-rays. We now have evidence that the ionized atom returns to its normal condition usually through a series of steps, and that at each step radiation is emitted whose frequency is proportional to the energy emitted. At the halting places, between the steps, the atom is said to be in one of its "stationary states," of which more will be said when we consider Bohr's theory of the atom.

If an electron is ejected from the innermost portion of the atom, where the energy is a minimum and the greatest amount of energy is therefore required to liberate the electron, a large amount of energy will correspondingly be liberated when an electron returns to the vacated position. The frequency of the fluorescent radiation emitted, being proportional to the energy radiated, will accordingly have the highest value possible for this atom.

There are two prominent types of fluorescent X-rays which

may be excited in most of the elements, known as the *K* and the *L* characteristic radiations.<sup>1</sup> The former is apparently the most penetrating type of fluorescent radiation which the element is capable of radiating, and is thus presumably excited when an electron is ejected from the most stable position in the atom. The *L* radiation is much less penetrating, and occurs when electrons are ejected from the next most stable position. It is a remarkable fact that similar characteristic fluorescent radiations are emitted from all the elements, which differ by regular gradations in penetrating power or wave-length as one goes from one element to another.

Spectra of these characteristic radiations, taken however directly from the target of the X-ray tube instead of from fluorescing matter, are shown below (p. 28) for several elements.

*Photoelectrons Ejected by X-rays.* According to the interpretation of fluorescent radiation which we have just given, emission of photoelectrons from matter exposed to the X-rays should always accompany the emission of fluorescent rays. This is indeed found to be the case. We can even distinguish the photoelectrons which are ejected from the different portions of the atom corresponding to the emission of a *K* or an *L* fluorescent ray. When light falls upon the alkali metals it has been found that photoelectrons are ejected with a kinetic energy whose maximum value is

$$\frac{1}{2}m\bar{v}^2 = h\nu - w, \quad (1.02)$$

where  $w$  is the work done in pulling the electron out of the metal,  $\nu$  is the frequency of the light, and  $h$  is a constant of proportionality known as "Planck's constant." When X-rays instead of light are employed, the photoelectrons are found to be ejected with different groups of velocities, but the energy of the fastest electrons in each group is again given by equation (1.02). The constant  $h$  keeps the same value,  $6.56 \times 10^{-27}$  erg seconds; but  $w$ , the work done in removing the electron from the atom, has a different value for the different groups of

<sup>1</sup> C. G. Barkla and C. A. Sadler, *Phil. Mag.* 16, 550 (1908).

photoelectrons. If it requires an amount of energy  $w_k$  to remove an electron from the lowest or  $K$  energy level, it is clear from equation (1.02) that such an electron cannot be ejected if  $h\nu < w_k$ , i.e., if the frequency of the incident X-rays is less than  $\nu = w_k/h = \nu_k$ . But if the electrons are not removed from the  $K$  level, it is impossible for any  $K$  fluorescent radiation to be emitted. This result has been fully verified by experiment, which shows that fluorescent radiation of the  $K$  or  $L$  type is not emitted by an element unless it is traversed by radiation whose frequency is greater than the critical value  $w_k/h$  or  $w_l/h$  required to eject photoelectrons from the corresponding energy levels.

It has been noted above that after ionization has occurred an atom usually returns to its normal condition through a series of steps. One of these steps may be the transition of an electron from an  $L$  to a  $K$  energy level, in which case the amount of energy liberated is  $w_l - w_k$ , which can be determined by measuring the difference in energy of the photoelectrons ejected from these two levels. It is interesting to note that the most prominent line in the spectrum of the fluorescent  $K$  radiation has the frequency  $\nu = (w_l - w_k)/h$ , where  $h$  is again Planck's constant. It is thus natural to suppose that if the energy liberated during any change of the electron's position in the atom is  $w$ , the frequency of the radiation emitted during the process is  $w/h$ . As we shall see, this is a fundamental postulate of Bohr's theory of spectra, and as a part of that theory has received very strong support.

It is a consequence of this postulate that the highest frequency fluorescent ray that can be excited is no greater than the frequency of the primary ray. For the greatest amount of energy which the primary ray can impart to an atom in ejecting an electron is  $h\nu$ , and this is therefore also the greatest amount of energy that can be liberated as a fluorescent ray when the atom returns to its normal condition. It will of course usually happen that the frequency of the fluorescent ray is considerably lower than that of the primary ray. This corresponds to Stokes' law in optics. Though the law is by no means always valid in

the visible region, in the region of X-rays no exceptions have been found.

### 5. Polarization of X-rays

According to the explanation of the scattering of X-rays given above, we should expect the rays scattered at an angle of  $90^\circ$  with the primary beam to be polarized. For the electric vector of the primary wave is perpendicular to the direction of propagation, and the accelerations of the scattering electrons must therefore also be perpendicular to this plane. If we were to look at these scattering electrons in a direction at right angles with the primary beam, their motions would all be in a plane which we would be seeing edge-on. Imagine, as in Fig. 7,

that the primary beam is propagated horizontally toward the north when it passes over the electron  $e$ . The acceleration of this electron will then be in a vertical, east-west plane. The electric vector of the wave which it emits toward the east must also lie

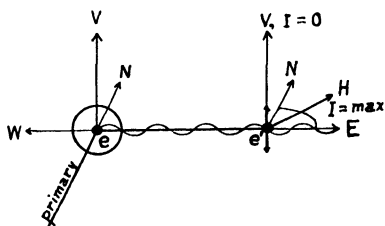

FIG. 7.

in this plane, since there is no component of the acceleration of the scattering electron in any other direction. Consequently, the scattered ray reaching an electron  $e'$ , having its electric vector in a vertical plane, is completely plane polarized.

This polarization may be detected by examining the rays scattered by the electron  $e'$ . This is accelerated in a vertical direction. The amplitude of the electric vector of the wave emitted is, according to the usual electrodynamics, proportional to the sine of the angle between the acceleration and the direction of propagation. Thus the maximum intensity of the beam scattered by electron  $e'$  is in the horizontal plane, while in the vertical direction the intensity is zero. The polarization of the beam scattered by electron  $e$  is thus detected by comparing the intensity of the scattered rays from electron  $e'$  in the horizontal and vertical directions.

A test of this character was first made by C. G. Barkla<sup>1</sup> in 1906. In place of the electrons  $e$  and  $e'$ , he used blocks of carbon to produce the scattering, and he compared the ionization produced in two chambers placed at  $H$  and  $V$  respectively. He found the ionization in the chamber  $H$  much more intense than in chamber  $V$ , thus proving that the rays scattered by the first radiator were strongly polarized. The fact that the scattered rays are thus polarized in the predicted manner gives strong evidence in favor of the view that the X-rays consist of electromagnetic waves or pulses.

### 6. *Diffraction and Interference of X-rays*

It was recognized early in the study of X-rays that most of the properties of these rays might be explained if they consisted of electromagnetic waves of wave-length much less than that of light. Many attempts were therefore made to secure diffraction of X-rays by passing them through a narrow slit. Haga and Wind performed a careful series of experiments<sup>2</sup> to detect any possible diffraction through a wedge-shaped slit a few thousandths of a millimeter broad at its widest part. Photographs were obtained which showed a broadening where the rays passed through the narrow part. The magnitude of the broadening was about that which would result<sup>3</sup> from rays of wave-length  $1.3 \times 10^{-8}$  cm. Walter and Pohl repeated the experiments by yet more refined methods,<sup>4</sup> and came to the conclusion that if any diffraction effects were present, they were considerably smaller than Haga and Wind had estimated. Later, A. Sommerfeld<sup>5</sup> recalculated the wave-lengths from Walter and Pohl's plates on the basis of photometric measurements performed by Koch.<sup>6</sup> He thus found from their photographs that the effective wave-length of hard X-rays is about  $4 \times 10^{-9}$  cm.,

<sup>1</sup> C. G. Barkla, Proc. Roy. Soc. A. **77**, 247 (1906).

<sup>2</sup> Haga and Wind, Wied. Ann. **68**, 884 (1899).

<sup>3</sup> A. Sommerfeld, Phys. Zeits. **2**, 59 (1900).

<sup>4</sup> Walter and Pohl, Ann. d. Phys. **29**, 331 (1909).

<sup>5</sup> A. Sommerfeld, Ann. d. Phys. **38**, 473 (1912).

<sup>6</sup> P. P. Koch, Ann. d. Phys. **38**, 507 (1912).

and that the wave-length of soft X-rays is measurably greater. These values are of the correct order of magnitude as tested by the methods of crystal spectroscopy. On account of the difficulties of the experiments, however, these results did not carry as great conviction as their accuracy would seem to have warranted.

Recently two experimenters, Walter<sup>1</sup> and Rabinov,<sup>2</sup> have repeated experiments of this type, using respectively the  $K_{\alpha}$  lines of copper and molybdenum. Both obtained definite diffraction effects and were able to make approximate estimates of the wave-length, which agreed within a rather large probable experimental error with the wave-lengths determined by crystal spectrometry. Walter's results are reproduced in Fig. 8, which shows a definite diffraction band beside the central image.

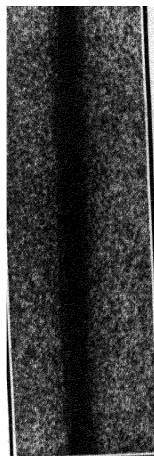

FIG. 8.

*Diffraction by Ruled Grating.* Though these photographs obtained with narrow slits show definite diffraction effects, they have not enabled us to make any precise determination of the X-ray wave-lengths. Absolute wave-lengths of X-rays have however been measured by means of ruled reflection gratings, similar to those used for visible light.<sup>3</sup> Though in the early experiments it was found impossible to reflect X-rays from a polished surface, later work (described on page 40) showed that such specular reflection does occur when the X-rays graze the surface at a sufficiently fine angle. Within this angle, of less than half a degree, it is thus possible to use a reflection grating.

<sup>1</sup> B. Walter, *Ann. der Phys.* **74**, 661 (1924); **75**, Sept., 1924.

<sup>2</sup> I. I. Rabinov, *Proc. N. A. Sci.* **11**, 222 (1925).

<sup>3</sup> The possibility of securing X-ray spectra from a ruled grating in this manner was first suggested by N. Carrara (*N. Cimento*, **1**, 107, 1924). His efforts to secure such spectra were, however, fruitless. R. L. Doan and the author, independently of Carrara, succeeded in obtaining such spectra, of which Fig. 9 is an example (*Proc. Nat. Acad. Sci.* **11**, 598, 1925). Similar spectra, using a grating ruled on glass, have also been secured by J. Thibaud (*Comptes Rendus*, Jan. 4, 1926).

A spectrum thus obtained when the  $K\alpha_1$  line from a molybdenum target is diffracted by a grating ruled on speculum metal is shown in Fig. 9. The line  $D$  is the image of the *direct* beam obtained with the grating removed. The *directly* reflected beam is at  $O$ , and the different orders of the diffracted beam

appear at  $-1, 1, 2, 3$ . Using the usual grating formula,

$$n\lambda = D (\sin i + \sin r),$$

where  $D$  is the grating space,  $i$  the angle of incidence and  $r$  the angle of diffraction, it is possible from such a photograph to calculate the absolute value of the wave-length. In this case  $D$  was .002 cm., and  $\lambda$  was calculated to be  $.707 \times 10^{-8}$  cm.

This very direct method of measuring X-ray wave-lengths is not at present as precise as the less direct method in which crystals are

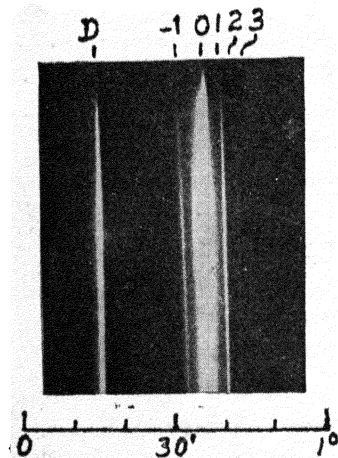

FIG. 9.

used as gratings. But the fact that the two methods give, within experimental error, identical results serves as an important confirmation of the crystal wave-length measurements.

*Diffraction of X-rays by Crystals.*—While these direct methods of measuring X-ray wave-lengths were being developed, and long before they were brought to a successful conclusion, Laue discovered the remarkable fact that crystals act as suitable gratings for diffracting X-rays. From this discovery has grown on the one hand a surprisingly exact knowledge of the structure of many crystals, and on the other hand a means of studying X-ray spectra which is comparable in precision with our methods of studying optical spectra.

Reasoning from several different standpoints, Laue estimated that the wave-length of ordinary X-rays should lie between  $10^{-8}$  and  $10^{-9}$  cm. But knowing as he did the number of molecules in unit volume of a substance, he noticed that the average distance between the atoms or molecules of solids was

between  $10^{-7}$  and  $10^{-8}$  cm. Now in a crystal, in order to get the symmetry which is observed, we must suppose that there is a unit, presumably of atomic or molecular size, which arranges itself in a regular repeating order. It is therefore natural to suppose that in a crystal there are layers of molecular units which are arranged successively at uniform distances not much greater than the wave-length of X-rays. But these conditions are very similar to those which occur when light traverses an optical grating—regularly spaced discontinuities separated by distances several times the wave-length of the light. It therefore occurred to Laue that a crystal might act toward X-rays in much the same manner as a grating acts toward light. He

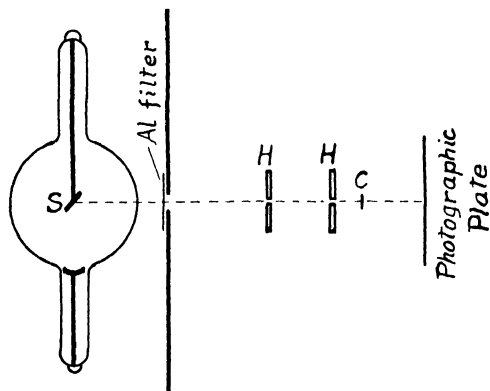

FIG. 10.

accordingly asked Friedrich and Knipping to try the experiment of passing a narrow beam of X-rays through a crystal of zinc blende.

The apparatus which was used in the original experiments is shown diagrammatically in Fig. 10. X-rays from the target *S*, after being collimated by two circular holes *HH*, passed through the zinc blende crystal *C* onto the photographic plate. In Fig. 11 is shown a photograph of the type thus obtained. Around the central spot, produced by the direct beam passing through the crystal, appear a group of symmetrically arranged spots. The positions of these spots changed when the orientation of

the crystals was altered, and was different for different crystals. They formed exactly the type of pattern which might have been expected from a three dimensional grating.

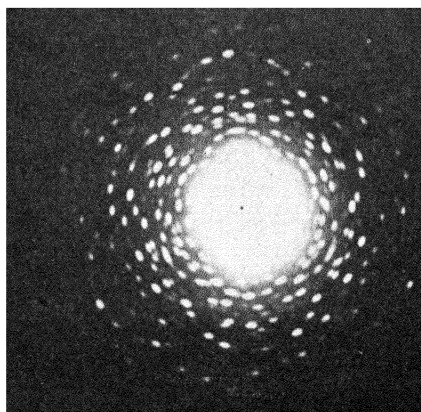

FIG. 11.

A simple interpretation of these photographs was offered by W. L. Bragg.<sup>1</sup> He pointed out that each of the images sur-

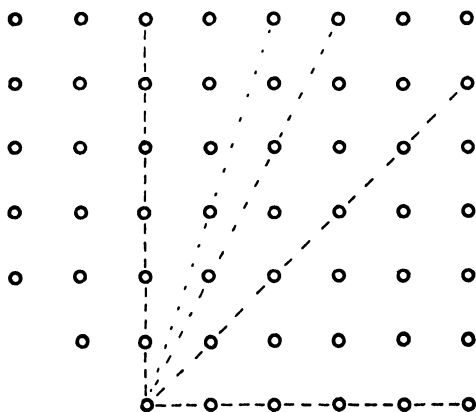

FIG. 12.

rounding the central spot could be interpreted as the reflection of the incident X-ray beam from some plane within the crystal

<sup>1</sup> W. L. Bragg, Proc. Camb. Phil. Soc. 17, 43 (1912).

which was especially rich in atoms. Consider a two-dimensional pattern of points as shown in Fig. 12. It will be seen that the lines (corresponding to the planes in the three dimensional crystal) which have many points per unit length are those drawn at "simple" angles. Similarly the position of the spots to be expected in a Laue photograph with a cubic crystal can be calculated on Bragg's assumption merely from the crystal symmetry, the more intense spots being reflected from planes drawn at simple angles with the cubic axes. A comparison with the position of the spots thus calculated with the positions of the spots in Friedrich and Knipping's photographs showed that the idea was sound.

The cleavage face of a crystal should be parallel to these "simple" planes which are rich in atoms. W. H. Bragg therefore tried the experiment of reflecting a beam of X-rays from the cleavage surface of a crystal, and found on the photographic plate a spot at the angle of reflection.<sup>1</sup> He then replaced the photographic plate with an ionization chamber, mounted

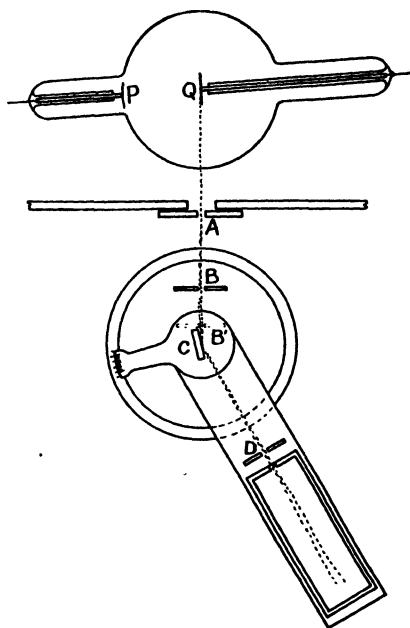

FIG. 13.

upon the arm of a spectrometer, and placed the crystal upon the prism table, so that both could be conveniently oriented at any desired angle with the primary beam. A diagrammatic plan of the apparatus as thus employed is shown in Fig. 13. *A* and *B* are slits which collimate the primary X-ray beam, *C* is the crystal, *D* is a slit which defines the beam entering the ioniza-

<sup>1</sup> It is interesting to note that Roentgen tried a rather similar experiment in 1895 using a crystal of calcite, but with negative results.

tion chamber *I*. As the glancing angle  $\theta$  at which the X-rays struck the crystal was varied, the angle between the ionization chamber and the primary beam was kept equal to  $2\theta$ , in order to receive the secondary beam reflected from the crystal.

A record of the intensity of ionization as the angle  $\theta$  was varied is shown in Fig. 14. In this experiment X-rays from a tube containing a platinum target were reflected by a crystal of rock-salt. It will be seen that instead of varying uniformly with the angle, the ionization rises to large values at certain sharply defined angles.

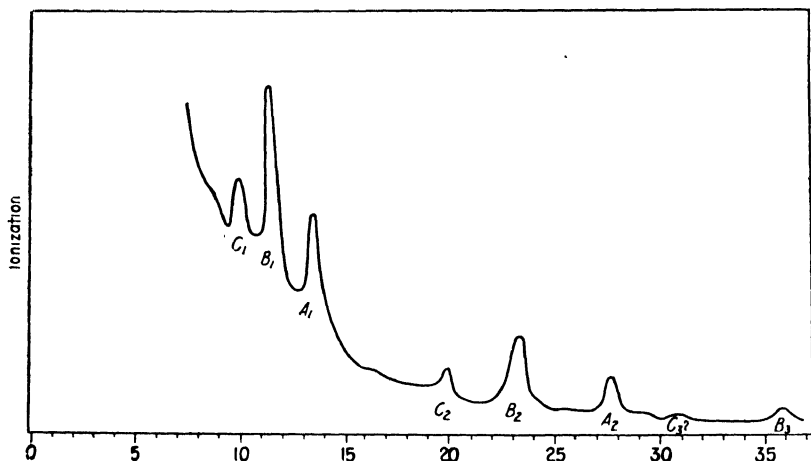

FIG. 14.

An interpretation of this curve may be obtained if we examine further the manner in which X-rays are diffracted by a crystal. Suppose that a wave comes from a source *S* and strikes a crystal, as in Fig. 15. A fraction of the wave is reflected by the first layer of atoms at an angle  $\theta$ , equal to the incident glancing angle, and another fraction is reflected from the second layer. It is clear from the construction of the figure that the difference in the length of the paths followed by these two rays is *ABC*. But  $AB = BC = OB \sin \theta$ , so that the difference in path is  $2 OB \sin \theta$ . In order to secure co-operation between these beams, the difference between their paths must

be an integral number of wave-lengths. It follows, writing  $OB = D$ , that

$$n\lambda = 2D \sin \theta, \quad (1.03)$$

where  $n$  is an integer, and represents the order of the diffraction.

According to this equation, a change of the angle  $\theta$  should alter the wave-length of the rays reflected from the crystal. It is therefore natural to suppose that the three peaks,  $A_1$ ,  $B_1$  and  $C_1$  represent X-ray spectrum lines. If this is the case, second orders of these lines should appear at angles whose sines are twice those of lines  $A_1$ ,  $B_1$  and  $C_1$ . Such lines actually do appear

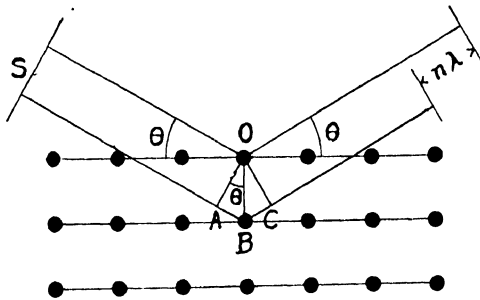

FIG. 15.

at  $A_2$ ,  $B_2$  and  $C_2$ , and not only are their angles just what they should be according to equation (3), but their relative intensities also are in the same ratio as those of the corresponding lines in the first order.

The fact that these lines are characteristic of the target from which the X-rays are emitted is shown by the fact that if an X-ray tube with a nickel target is substituted for the one with the platinum target, an entirely different type of spectrum is observed, two lines instead of three appearing, and at different angles. If, on the other hand, the crystal is changed, the same lines appear with about the same relative intensity, but the angles at which they appear is changed, indicating, according to equation (3), that the grating space between the layers of atoms is different for different crystals. It is therefore clear

that we are dealing here with true spectra of X-rays characteristic of the target, diffracted by a crystal grating.

If the distance between the layers of atoms can be determined, we can by this means measure the wave-length of the X-ray spectrum lines emitted by different metals used as targets. We shall show in Chapter IV that there is good reason to believe that the atoms in a crystal of sodium chloride are

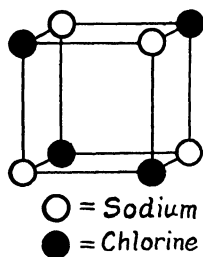

FIG. 16.

arranged alternately at the corners of a cubic lattice, thus (Fig. 16). Now if the number of molecules per gram molecule is  $N = 6.06 \times 10^{23}$ , the molecular weight of sodium chloride  $W = 58.5$ , and its density  $\rho = 2.17$ , then the number of molecules per  $\text{cm}^3$  of rock-salt is  $N\rho/W$ , and the number of atoms is  $2N\rho/W$ . The average volume occupied by each atom is thus  $W/2N\rho$ , and since the

atoms are arranged cubically, the distance between the adjacent atoms is

$$D = (W/2N\rho)^{1/3},$$

or when the numerical values are substituted,

$$D = 2.81 \times 10^{-8} \text{ cm. (rock-salt).}$$

In the case of calcite, the grating space calculated in a similar manner is

$$D = 3.029 \times 10^{-8} \text{ cm. (calcite).}$$

Having thus determined the grating space between the layers of atoms in rock-salt, we can now measure the absolute wave-lengths of the X-rays. Thus in Fig. 14 the  $B_1$  peak occurs at about  $11.4^\circ$ . Substitution this angle in equation (3), using  $n = 1$ , and  $D = 2.81 \times 10^{-8}$  for rock-salt, we find for the wave-length of this line, 1.12 Ångströms, where 1 Å =  $10^{-8}$  cm.

We have seen that the wave-lengths of the X-ray spectrum lines as thus measured agree accurately with those measured by ruled diffraction gratings of known spacing. The values of  $D$  calculated for the crystals are thus confirmed. This means in

turn that we have assumed the correct fundamental structure for the rock-salt and the calcite crystals.

### 7. *X-ray Spectra*

A systematic study of the X-ray spectra of the different elements was first made by Moseley<sup>1</sup> in 1913-14. His experiments covered a range of from 0.4 to 8 Å., using 38 different elements as targets of his X-ray tube. He found that the spectrum lines emitted by these elements belonged to two very distinct series, which were identified with the *K* and *L* types of characteristic fluorescent radiation which had previously been observed by Barkla and Sadler. Moseley's photographs of the X-ray spectra of the *K* or shortest wave-length series lines from the elements of atomic weight between 40 and 65 are shown in Fig. 17. Since in these spectra the wave-lengths are nearly proportional to the angles, the wave-lengths can be taken as nearly proportional to the distances of the lines from the left-hand side of the figure.

The most striking thing in this figure is the great regularity of the spectra. Each element exhibits a spectrum identical with that of the other elements except that the scale of wave-lengths is changed. It will be noticed also that as one goes from the lighter to the heavier elements, the wave-length of the corresponding lines decreases in a regular manner. Thus even if we did not know that there is an element scandium between the elements calcium and titanium, the large gap between the spectra of these two elements would have suggested strongly that such an element should exist. An examination of these spectra revealed the fact that the square root of the frequency of either of the two lines in this spectrum is nearly proportional to the atomic number of the radiator, or more exactly, that the frequency is given by

$$\nu^{1/2} = K(N - k) \quad (1.04)$$

Here *K* is a universal constant for all elements, *N* is the atomic number, and *k* is another universal constant. This is usually

<sup>1</sup> H. G. J. Moseley, *Phil. Mag.* 26, 1024 (1913); 27, 703 (1914).

spoken of as Moseley's law. It applies not only to the *K* series lines as shown in Fig. 17, but also, with appropriate changes in the values of the constants *K* and *k*, to the lines of the *L* series. While precise experiments have shown that this law is not exact, it is nevertheless sufficiently accurate for many purposes, and affords, as we shall see, an important clue to the origin of these spectrum lines.

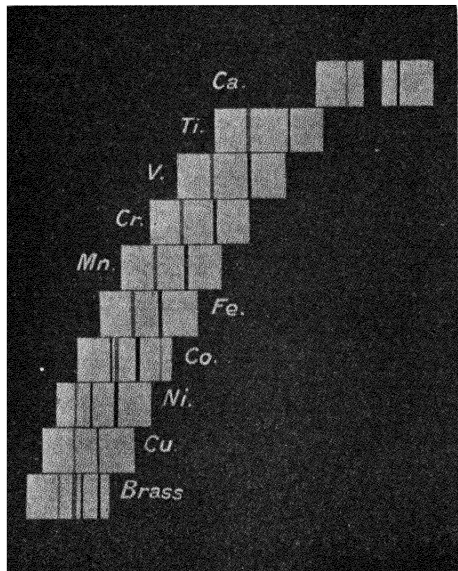

FIG. 17.

The appearance of the *L*-series lines is beautifully shown by Siegbahn's photographs in Fig. 18. The spectra of these elements also exhibit the same regular changes that are found in the spectra of the *K* series, but the spectrum has a considerably greater number of lines. Two series of still greater wave-length are known, an *M* series and an *N* series. It has been possible to examine these spectroscopically only for the heavier elements. The spectrum of the *M* series of tungsten, as obtained by Stenström, is shown in Fig. 19. Tables of the wave-lengths of the different X-ray spectrum lines are given in the appendix.

*The Continuous X-ray Spectrum.*—The continuous portion of the X-ray spectrum also has some very interesting features. In Fig. 20 are shown a series of spectra obtained by Ulrey from a tungsten target, taken with different potential differences

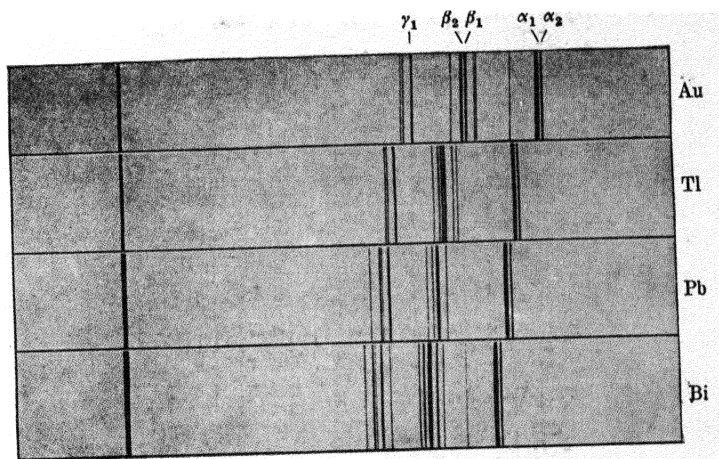

FIG. 18.

across the X-ray tube. It will be seen that for a definite potential, no radiation occurs of wave-length less than a certain critical value. Having passed this wave-length, the intensity rises sharply to a maximum, and then gradually falls to a relatively low value.



FIG. 19.

Accurate measurements show that the short wave-length limit of the spectrum is inversely proportional to the potential applied to the tube, or that the frequency of this limiting radiation is proportional to the potential. It is customary to state this fact thus:

$$Ve = h\nu_{\max.} = hc/\lambda_{\min.} \quad (1.05)$$

In this expression,  $V$  represents the potential across the tube and  $e$  the charge on the electron, so that  $Ve$  is the energy with which the cathode ray strikes the target;  $c$  is the velocity of light, and  $h$ , the constant of proportionality, is the same as Planck's constant which we used in discussing the photoelectric

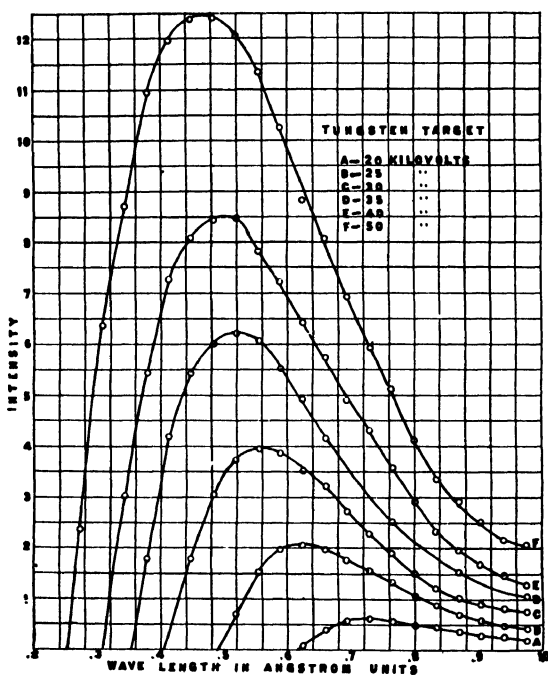

FIG. 20.

effect. From careful determinations of the minimum wavelength  $\lambda_m$  corresponding to definite potentials  $V$ , Duane and his collaborators have found<sup>1</sup>

$$\begin{aligned}
 h &= Ve\lambda_m/c, \\
 &= 6.556 \times 10^{-27} \text{ erg sec.}
 \end{aligned}$$

<sup>1</sup> Blake and Duane, Phys. Rev. 10, 624 (1917). Duane, Palmer and Chi-Sun-Yeh, J. Opt. Soc. Am., 5, 376 (1921).

### 8. Bohr's Theory of Spectra

In order to understand the significance of the remarkable regularities observed in the X-ray spectra, we may profitably consider at this point Bohr's theory of the structure of the atom. For the present we shall discuss this only in a simple form, leaving till a later chapter the detailed theory which will account more completely for the different lines observed. Bohr's theory<sup>1</sup> postulates the type of atom proposed by Rutherford, which consists of a heavy, positively charged nucleus about which the negative electrons revolve in orbits. He proceeds, on the basis of three principal assumptions, to calculate the positions and the energies of the electrons in their orbits and the frequency of the radiation which they may emit.

The first of these assumptions is that an electron revolves in a circular orbit,<sup>2</sup> its centrifugal force being balanced by the electrostatic attraction of the nucleus modified by the forces due to the other electrons in the atom. For a single electron revolving about a nucleus, the mathematical statement of this assumption is

$$\frac{mv^2}{a} = \frac{Ee}{a^2} = \frac{Ze^2}{a^2},$$

where  $m$  is the mass of the electron whose charge is  $e$ ,  $v$  is its speed in its orbit of radius  $a$ , and  $E = Ze$  is the charge on the nucleus,  $Z$  being the atomic number.<sup>3</sup>

<sup>1</sup> N. Bohr, *Phil. Mag.* 6, 1, 476-857 (1913).

<sup>2</sup> Bohr's original assumption was an elliptical orbit. The assumption of a circular orbit is made here for the sake of simplicity, since it leads to the same results regarding frequencies and energies.

<sup>3</sup> Rutherford's experiments (*Phil. Mag.* 21, 669 1911) demonstrated the existence of a small and massive nucleus within the atom which repelled alpha particles according to an inverse square law of force. The magnitude of this force was shown to be about that which should exist if this nucleus possessed a charge of about half the atomic weight. More recent experiments by Chadwick (*Phil. Mag.* 40, 734 1920) on the scattering of alpha rays showed that, measured in electronic units, this charge is at least very nearly equal to the atomic number. These results are supported by Barkla's measurements of the scattering of X-rays (cf. Chapter III), which indicate that the number of mobile electrons in an atom is equal to about half the atomic weight. The assumption that the charge on the atomic nucleus is, in electronic units, exactly equal to the atomic number is therefore strongly supported.

In every atom except hydrogen there exists more than 1 electron, and the forces due to the other electrons must be considered. If these electrons could be considered as charges uniformly distributed over the surface of spheres concentric with the nucleus, it is clear that those electrons outside the one whose motion is considered would have no effect, while those inside this orbit would act as if their total charge were concentrated at the nucleus. The force due to the outer electrons would thus be zero, and that due to the inner electrons would be  $pe^2/a^2$ , where  $p$  is the number of inner electrons. This correction is of course only approximate, since the electrons are not uniformly distributed over a spherical surface, and since the electron under consideration will itself doubtless modify to some extent the distribution of the other electrons. If the remaining electrons at the same distance from the atomic nucleus were similarly arranged at random on a spherical surface, a simple electrostatic argument shows that the force which they would produce on the electron in question would be a repulsion of magnitude  $\frac{1}{2}(q-1)e^2/a^2$ , where  $q$  is the total number of electrons in this shell. A more accurate expression for the electric force on the electron would therefore be

$$\frac{Ze^2}{a^2} - \frac{pe^2}{a^2} - \frac{1}{2} \frac{(q-1)e^2}{a^2} = F \frac{e^2}{a^2}$$

where  $F = Z - p - \frac{1}{2}(q-1)$ .

The relation between the centrifugal and the centripetal forces is thus more nearly

$$\frac{mv^2}{a} = \frac{e^2}{a^2} F. \quad (1.06)$$

The second assumption made by Bohr states that of the infinite variety of orbits which are possible according to equation (1.06) only those orbits will be stable for which the angular momentum is an integral multiple of  $h/2\pi$ , where  $h$  is Planck's constant, having the value  $6.556 \times 10^{-27}$  erg seconds. The idea is that, whereas according to the classical electrodynamics an electron revolving in an orbit must radiate because

of its centripetal acceleration, if an atom of the type postulated by Rutherford is to exist, there must be some condition under which the revolving electron will not radiate. It is the present assumption which supplies that condition, assigning to the electron certain orbits in which radiation will not occur. The assumption is to large extent arbitrary, its chief justification lying in the fact that it leads to results in agreement with experiment. The mathematical statement of this assumption is

$$mva = nh/2\pi, \quad (1.07)$$

where  $n$  is an integer.

By combining equation (1.06) and (1.07), we can calculate the radii and the energies corresponding to the different stationary states. On solving for the radius we obtain

$$a = \frac{n^2 h^2}{4\pi^2 F e^2 m}. \quad (1.08)$$

The total energy of the system is the sum of its potential and kinetic energies. In calculating the potential energy, let us suppose that initially the dimensions of all the electron orbits are magnified by a very large factor  $N$ , so that the potential energy is zero, though the electrons retain their usual relative positions. As  $N$  is gradually reduced to unity, the electron orbits shrink to their normal size. At each stage of this process, the force on the electron whose potential energy we calculate is always  $-F'e^2/r^2$ , where  $r$  is its distance from the nucleus, and  $F'$  has the value given above. Thus the work done on the electron in bringing it to its final position is

$$U = - \int_{\infty}^a \frac{F'e^2}{r^2} dr = - F'e^2/a,$$

or substituting the value of  $a$  from equation 1.08, the potential energy is

$$U = - \frac{4\pi^2 e^4 F'^2 m}{n^2 h^2}.$$

To calculate the kinetic energy, we have merely to evaluate  $\frac{1}{2}mv^2$  from equations (1.06) and (1.07), obtaining

$$T = \frac{1}{2}mv^2 = \frac{2\pi^2e^4F^2m}{n^2h^2}.$$

The total energy is accordingly

$$W = U + T = -\frac{2\pi^2e^4F^2m}{n^2h^2} \quad (1.09)$$

where, as before,

$$F = Z - p - \frac{1}{2}(q - 1).$$

Before proceeding with the third assumption, it will be of value to test the theory at this point. The energy required to remove an electron from its orbit is  $-W$  where  $W$  is given by equation (1.09).<sup>1</sup> If this energy is supplied by an electron striking the atom, in order to have acquired sufficient energy the electron must have fallen through a potential difference  $V$  such that  $Ve = -W$ . Thus the "ionizing potential" of the atom is

$$V = -\frac{W}{e} = \frac{2\pi^2e^3F_m^2}{n^2h^2}.$$

In the simplest case, that of the hydrogen atom,  $F = Z = 1$ , and if the atom is in its normal condition  $n = 1$ . On substituting the usual values,

$$e = 4.774 \times 10^{-10} \text{ e. s. u.},$$

$$m = 9.01 \times 10^{-28} \text{ g.},$$

$$h = 6.556 \times 10^{-27} \text{ erg sec.},$$

we find

$$V = .045 \text{ e. s. u.}$$

$$= 13.5 \text{ volts (calc.)}.$$

<sup>1</sup> From the way in which we have calculated the potential energy, it will be seen that this statement is only approximately true when the shielding effect of the other electrons is considered. It is strictly accurate, however, for hydrogen where  $F = Z$ .

The recent experiments of Olmstead and Compton,<sup>1</sup> however, have shown that in order that an electron may ionize an atom of hydrogen, it must have fallen through a potential difference

$$V = 13.54 \text{ volts (expt.)},$$

in perfect accord with the theory. This suggests strongly that we are working along the right line, especially since when Bohr originally proposed his theory the ionization potential of hydrogen was considered to differ very considerably from this value.

Bohr's third assumption enables us to predict the frequency of the radiation emitted by the atom. He supposes that if an electron finds itself in an outer orbit ( $n > 1$ ) it may drop to an inner orbit, and that the energy liberated in the process is radiated with a definite frequency such that

$$h\nu = W_i - W_f, \quad (1.10)$$

where  $W_i$  is the energy of the atom in its initial state and  $W_f$  its energy in the final state.<sup>2</sup> From equation (1.09) the frequency of the emitted radiation should therefore be

$$\nu = \frac{2\pi^2 e^4 m}{h^3} F_f^2 \left\{ \frac{1}{n_f^2} - \frac{F_i^2}{F_f^2} \frac{1}{n_i^2} \right\},$$

where as before the subscripts  $f$  and  $i$  refer to the final and initial states of the electron respectively. Since  $1/n_i^2$  is usually small compared with  $1/n_f^2$ , we can without serious error put  $F_i^2/F_f^2 = 1$ , and writing

$$R \equiv \frac{2\pi^2 e^4 m}{h^3},$$

the expression for the frequency becomes

$$\nu = R \cdot F_f^2 (1/n_f^2 - 1/n_i^2). \quad (1.11)$$

In the case of hydrogen  $F_f = Z = 1$  exactly, and substituting the values of  $e$ ,  $m$  and  $h$  given above, the frequencies of the

<sup>1</sup> P. S. Olmstead and K. T. Compton, Phys. Rev. 22, 559 (1923).

<sup>2</sup> We shall see later (Chapter X) that this assumption is not independent of the second assumption.

various spectrum lines can be calculated. For  $n_f = 2$  and  $n_i = 3, 4, 5$ , etc., this formula gives the frequencies of the visible hydrogen lines and those in the ultraviolet which compose what is known as the Balmer series. Within experimental error the agreement is exact. Thus for example, if  $n_f = 2$  and  $n_i = 3$ , the calculated wave-length is  $\lambda = c/\nu = 6.75 \times 10^{-5}$  cm., while the observed wave-length is  $6.563 \times 10^{-5}$  cm. For  $n_f = 1$ , the frequencies are much greater, and correspond exactly with those of the Lyman series of hydrogen. Similarly, for  $n_f = 3, 4$  and  $5$ , the various values of  $n_i$  give frequencies which agree accurately with those of known lines in the infra red spectrum of hydrogen. Thus equation (I.11) predicts accurately the position of all the known lines of atomic hydrogen, and does not predict any lines which do not occur under suitable conditions.

When we apply this formula to the case of X-ray spectra, we may take the experimental value of  $R$  as  $3.29 \times 10^{15}$  sec.  $^{-1}$ , as determined from optical spectra, instead of the value  $3.19 \times 10^{15}$  calculated from the measured values of  $e$ ,  $m$  and  $h$ . For the  $K\alpha$  line of molybdenum, we have  $Z = 42$ , and supposing that the  $K$  rays come from the innermost shell of electrons, we may take  $p = 0$  and  $q = 2$ .<sup>1</sup> Thus  $F_f = 41.5$ . Since the  $K\alpha$  line is the longest of this series, we may take  $n_f = 1$  and  $n_i = 2$ . Substituting these quantities in equation (I-11) we find  $\lambda = c/\nu = 0.70 \times 10^{-8}$  cm., which agrees very satisfactorily with the value  $0.71 \times 10^{-8}$  cm. determined experimentally. Similarly for the  $L\alpha$  line from tungsten, we have  $N = 74$ ,  $p = 2$  and  $q = 8$ , whence  $F_f = 68.5$ ;  $n_f = 2$ , and  $n_i = 3$ . Thus  $\lambda = 1.40 \times 10^{-8}$  cm., which again agrees acceptably with the experimental value  $1.47 \times 10^{-8}$  cm.

If we write

$$K^2 = R \left( \frac{1}{n_f^2} - \frac{1}{n_i^2} \right)$$

<sup>1</sup> The assumption that there are two electrons in the inner shell is suggested by the fact that helium has but two electrons, and that the chemical properties of lithium indicate that it has one electron, boron two electrons, etc., which are active in chemical reactions. This leaves two electrons in each of these atoms inert, and hence presumably in an inner shell. A number of other lines of evidence lead to the same conclusion.

and

$$F_f \equiv Z - \{p + \frac{1}{2}(q - 1)\} = Z - k,$$

equation (1.11) becomes

$$\nu^{1/2} = K(Z - k),$$

which is identical with Moseley's experimental law (1.04). These results thus indicate that  $Z$ , the charge on the nucleus of the atom, increases by 1 electronic unit as one passes from an element to the element next higher in atomic weight. Moreover, since  $k$  remains constant, the number of electrons in the inner shells must remain constant for the elements for which the spectra are examined. These X-ray spectra, with the help of Bohr's theory, therefore supply very valuable evidence concerning the inner structure of the atom.

### 9. *The Refraction of X-rays*

In his original examination of the properties of X-rays, Roentgen tried unsuccessfully to obtain refraction by means of prisms of a variety of materials such as ebonite, aluminium and water. Previous to the use of homogeneous rays reflected from crystals, perhaps the experiment conducted under conditions most favorable for measurable refraction was one by Barkla.<sup>1</sup> In this work X-rays of a wave-length which excited strongly the characteristic  $K$  radiation from bromine were passed through a crystal of potassium bromide. The accuracy of his experiment was such that he was able to conclude that the refractive index for a wave-length of 0.5 Å. probably differed from unity by less than  $5 \times 10^{-6}$ . A test of the refraction of homogeneous X-rays has been made by Webster and Clark.<sup>2</sup> They found that the refractive index for the different  $K$  lines of rhodium, transmitted by a rhodium prism, differed from unity by less than about  $3 \times 10^{-4}$ .

Although these direct tests for the refraction of X-rays were unsuccessful, Stenström has observed<sup>3</sup> that for X-rays whose

<sup>1</sup> C. G. Barkla, *Phil. Mag.* **31**, 257 (1916).

<sup>2</sup> D. I. Webster and H. Clark, *Phys. Rev.* **8**, 528 (1916).

<sup>3</sup> W. Stenström, *Dissertation*, Lund (1919).

wave-lengths are greater than about  $3\text{\AA}$ , reflected from crystals of sugar and gypsum, Bragg's law,  $n\lambda = 2D \sin \theta$ , does not give accurately the angles of reflection. He interprets the difference as due to an appreciable refraction of the X-rays as they enter the crystal. Precise measurements by Duane<sup>1</sup> and Siegbahn<sup>2</sup> have shown that the same type of discrepancies occur, though they are very small indeed, when ordinary X-rays are reflected from calcite.

The direction of the deviations in Stenström's experiments indicated that the index of refraction of the crystals employed was less than 1. If this is the case also for other substances, total reflection should occur when X-rays in air strike a plane surface at a sufficiently sharp glancing angle, just as light in a glass prism is totally reflected from a surface separating the glass from the air if the light strikes the surface at a sufficiently sharp angle. The condition for total reflection is that  $\sin r = 1/n \sin i > 1$ , where  $i$  is the angle of incidence,  $r$  is the angle of refraction, and  $n = \sin i / \sin r$  is the index of refraction. For in this case the angle of refraction is imaginary, and all of the energy must be refracted. In terms of the glancing angle  $\theta$ , which is the complement of the angle of incidence  $i$ , this may be written,  $1/n \cos \theta > 1$ , i.e.,  $\cos \theta > n$ , or approximately,

$$\theta = \sin \theta < \sqrt{2} \sqrt{1 - n}, \quad (1.12)$$

By measuring this critical angle for total reflection, we can thus measure the index of refraction of the X-rays.

The experiment has been carried out by the author<sup>3</sup> using the apparatus shown in Fig. 21. A very narrow sheet of X-rays fell upon the mirror  $M$ , and was reflected onto the crystal of a Bragg spectrometer. It was found that the beam could be reflected from surfaces of polished glass and silver through angles of several minutes of arc. By investigating the spectrum of the reflected beam, it was possible to show that the critical glancing angle is approximately proportional to the

<sup>1</sup> Duane and Patterson, *Phys. Rev.* **16**, p. 532 (1920).

<sup>2</sup> M. Siegbahn, *Comptes Rendus*, **173**, p. 1350 (1921); pp. 174, 745 (1922).

<sup>3</sup> A. H. Compton, *Phil. Mag.* **45**, 1121 (1923).

wave-length, which means, according to equation (1.12), that the index of refraction differs from unity by an amount proportional to the square of the wave-length. For glass and silver, also, the quantity  $1 - n$  for a given wave-length is approximately proportional to the density. For the wave-length  $1.279\text{\AA}$  crown glass of density 2.52 was found to have a critical angle of  $\theta = 11'$ , corresponding to an index of refraction  $n = 1 - 5 \times 10^{-6}$ . We shall see later (Chapter VII) that these total reflection experiments are in good accord with the usual electron theory of dispersion.

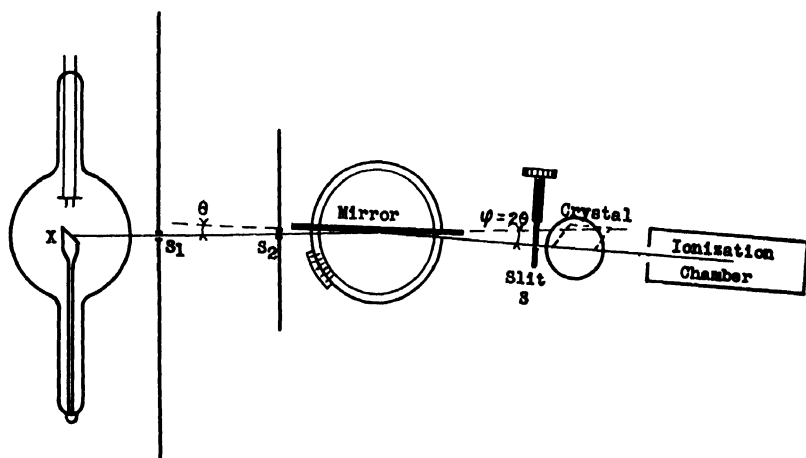

FIG. 21.

More recent experiments by Von Nardroff<sup>1</sup> and Hatley,<sup>2</sup> using a modification of Stenström's method, and by Larson, Siegbahn and Waller,<sup>3</sup> who have finally succeeded in deviating the X-rays by means of a prism, have confirmed these results, obtaining measurements of the refractive index of surprisingly high accuracy. A more detailed account of this work is given in Chapter VII.

<sup>2</sup> R. Von Nardroff, *Phys. Rev.* **24**, 143 (1924).

<sup>3</sup> C. C. Hatley, *Phys. Rev.* **24**, 486 (1924).

<sup>1</sup> A. Larson, M. Siegbahn and T. Waller, *Phys. Rev.* **25**, p. 245 (1925).

## CHAPTER II

### ELECTROMAGNETIC THEORY OF THE PRODUCTION OF X-RAYS

#### 10. *Electromagnetic Pulses*

The first hypothesis regarding the nature of X-rays which led to important results was that put forward by Stokes<sup>1</sup> and J. J. Thomson.<sup>2</sup> On this view the X-rays consist of irregular electromagnetic pulses due to the irregular accelerations of the cathode particles as they traverse the atoms of the target.<sup>3</sup>

The intensity of the radiation emitted by an accelerated electron may be calculated by an application of Maxwell's conception of displacement currents. Just as an electromotive force is induced in a circuit toward which a magnetic pole is moving, so a magnetomotive force is induced by the motion of an electric charge. The use of the idea of displacement currents may be illustrated by calculating on this basis the magnetic field due to a moving electron.

#### 11. *Field Due to an Electron in Slow, Uniform Motion*

Imagine, as in Fig. 22, an electron moving along the X-axis with a velocity  $v$  small compared with the velocity of light  $c$ . We wish to determine the magnetic field at a point  $P$  ( $r, \theta$ ). If we draw through  $P$  a sphere about the electron at  $O$  as a center, the number of unit lines of electric force, or the electric "displacement" across the sphere is equal to the charge  $e$ . If,

<sup>1</sup> G. Stokes, Proc. Manchester, Lit. and Phil. Soc., 1898.

<sup>2</sup> J. J. Thomson, Phil. Mag. 45, 172 (1898); "Conduction of Electricity through Gases," 2d Ed., 658 et seq.

<sup>3</sup> The conception of X-rays as transverse ether waves of very short wave-length was suggested somewhat earlier by E. Wiechert (Sitzungsber. d. phys-ikon. Ges. zu Königsberg, 1894).

however, we consider the circle  $PSQ$ , perpendicular to  $OX$ , the displacement through this circle is

$$\begin{aligned}
 D &= e. \frac{\text{Area of Zone } PRQ}{\text{Area of whole sphere}} \\
 &= e. \frac{MR}{2OR} \\
 &= \frac{1}{2}e(1 - \cos \theta). \qquad (2.01)
 \end{aligned}$$

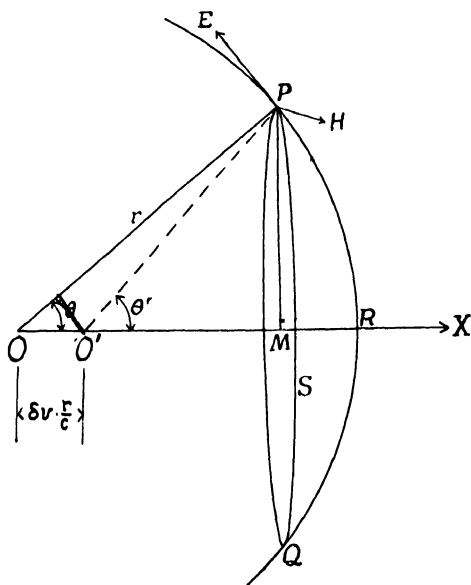

FIG. 22.

The *displacement current* passing through the circle  $PSQ$  is  $i_D = dD/dt$ , and this is supposed to produce precisely the same magnetic effect as if  $dD/dt$  were the rate at which electric current traversed the circle. The work done in carrying unit magnetic pole about this circuit is thus

$$\int H ds = \frac{4\pi}{c} i_D, \qquad (2.02)$$

where the magnetic field  $H$  is in e.m.u., and the displacement current  $i_D$  is in e.s.u., or,

$$\begin{aligned} H \cdot 2\pi r \sin \theta &= \frac{4\pi}{c} \frac{d}{dt} \left[ \frac{1}{2} e (1 - \cos \theta) \right] \\ &= \frac{2\pi e}{c} \sin \theta \frac{d\theta}{dt}. \end{aligned}$$

That is,

$$H = \frac{e}{rc} \frac{d\theta}{dt}.$$

Since  $d\theta = dx \sin \theta / r$ ,  $d\theta/dt = \frac{1}{r} \sin \theta \frac{dx}{dt} = \frac{v}{r} \sin \theta$ .

Thus 
$$H = \frac{ev}{r^2c} \sin \theta. \quad (2.03)$$

It will be seen that this is the same magnetic field at  $P$  as one calculates from Ampere's rule,

$$dH = \frac{id_s}{r^2c} \sin \theta,$$

if  $ev$  is taken as equivalent to the element of current  $ids$ .

## 12. Field Due to Accelerated, Slowly Moving, Electron

Referring again to Fig. 22, let us now imagine an electron moving with a small uniform velocity  $\delta v$  along the  $X$  axis, which is stopped at the point  $O$  in a short interval of time  $\delta t$ . We wish to calculate the intensity of the electromagnetic pulse at  $P$  resulting from this change in the electron's motion.

At the instant  $t = 0$ , the electron is at the point  $O$ , and since it has been in slow uniform motion, its field is the same in all directions. The displacement through the circle  $PSQ$  is now, as in equation (2.01),

$$\frac{1}{2} e (1 - \cos \theta).$$

After the additional short time interval  $\delta t$  the electron has stopped close to  $O$ . But an observer at  $P$  is unaware of this

change in the electron's motion until after the time  $r/c$ , required for an electromagnetic pulse to move from  $O$  to  $P$ . At the instant  $t = r/c$ , therefore, the field at  $P$  is just as it would be if the electron had continued to move with uniform velocity  $\delta v$  during this interval, reaching a point  $O'$  at a distance  $\delta x = \delta v \cdot r/c$  from  $O$ . The displacement through  $PSQ$  is now therefore  $\frac{1}{2}e(1 - \cos \theta')$ . But at the moment  $t = r/c + \delta t$ , and forever after, the field at  $P$  is that due to an electron at rest at  $O$ , so the displacement is again  $\frac{1}{2}e(1 - \cos \theta)$ .

During the short interval from  $t = r/c$  to  $t = r/c + \delta t$  the displacement has accordingly changed at the average rate,

$$\frac{\delta D}{\delta t} = \frac{1}{2}e(\cos \theta' - \cos \theta) / \delta t,$$

or

$$\begin{aligned} i_D &= \frac{1}{2}e \frac{\delta \cos \theta}{\delta t} \\ &= -\frac{1}{2}e \sin \theta \frac{\delta \theta}{\delta t}. \end{aligned}$$

But

$$\delta \theta = \frac{\delta x}{r} \sin \theta = \frac{\delta v}{c} \sin \theta,$$

whence

$$\frac{\delta \theta}{\delta t} = \frac{1}{c} \sin \theta \frac{\delta v}{\delta t} = -\frac{a}{c} \sin \theta,$$

where  $a = -\frac{\delta v}{\delta t}$  is the acceleration to which the electron is subject. It follows that

$$i_D = \frac{1}{2} \frac{ae}{c} \sin^2 \theta.$$

As in equation (2.02) we have therefore,

$$H \cdot 2\pi r \sin \theta = \frac{4\pi}{c} \frac{1}{2} \frac{ae}{c} \sin^2 \theta,$$

$$H = \frac{ae \sin \theta}{rc^2}. \quad (2.04)$$

When a magnetic field moves perpendicular to itself with a velocity  $v$ , it gives rise to an electric field of strength  $E = H \cdot \frac{v}{c}$  if  $E$  is expressed in electrostatic and  $H$  in electromagnetic units. In the present case, since the velocity of propagation of the pulse is  $v = c$ , the intensity of the electric field of the pulse in these units is identical with that of the magnetic field, *i.e.*,

$$E = H = \frac{ae}{rc^2} \sin \theta. \quad (2.05)$$

It will be noticed that these electric and magnetic intensities due to the electron's acceleration vary inversely as the distance  $r$  at which they are observed. But the electric intensity due to a stationary charge and the magnetic intensity (equation 2.03) due to a charge in uniform motion vary inversely as the square of the distance. Thus the radiation from the electron may be perceptible at distances so great that its electrostatic field is negligible.

The energy in the electromagnetic field is  $H^2/8\pi + E^2/8\pi$  per unit volume, where, as above,  $H$  is the magnetic intensity expressed in e.m.u., and  $E$  is the electric intensity expressed in e.s.u. The energy density in the pulse may thus be written, since  $E$  and  $H$  are equal, as

$$\frac{E^2}{4\pi} = \frac{e^2 a^2 \sin^2 \theta}{4\pi r^2 c^4}.$$

To obtain the total energy in the pulse, we integrate this quantity throughout the spherical shell of radius  $r$  and of thickness  $\delta r$ , thus:

$$W = \int_0^\pi 2\pi r \sin \theta \cdot r d\theta \cdot \delta r \cdot \frac{e^2 a^2 \sin^2 \theta}{4\pi r^2 c^4} = \frac{2}{3} \frac{e^2 a^2}{c^4} \delta r. \quad (2.06)$$

The fact that this energy is independent of the radius of the shell means that the total energy within the pulse remains constant as it leaves the electron with the velocity of light. This therefore represents energy which is actually escaping from the electron in the form of radiation.

The rate at which the energy is radiated while the electron is being accelerated may be calculated by finding the rate at which the energy in the radiated pulse traverses a fixed spherical surface described about the electron. In equation (2.06), if we write  $\delta r = c\delta t$ , it is clear that the energy  $E$  of the pulse traverses any fixed concentric spherical surface in the interval  $\delta t$ , whence the rate at which the energy is radiated is

$$\frac{dW}{dt} = \frac{2e^2 a^2}{3c^3}. \quad (2.07)$$

### 13. Intensity of X-rays on the Pulse Theory<sup>1</sup>

Let us assume, in accord with Stokes's idea, that an electron, when it strikes the target, is subjected to a negative acceleration in the direction of motion, which continues until the electron has been brought to rest. We wish to calculate the intensity and energy of the radiation which it emits. We are now dealing with an electric charge whose velocity is comparable with that of light, and the results which we have obtained for low velocities will be somewhat modified. If at any instant the electron's velocity is  $\beta c$ , it can be shown (see Appendix 1, equation 33) that equation (2.05) should be replaced by

$$E = H = \frac{ae}{rc^2} \frac{\sin \theta}{(1 - \beta \cos \theta)^3} \quad (2.08)$$

By the intensity of the radiation we mean the energy which crosses unit area, taken perpendicular to the direction of propagation, per unit time. Since the energy per unit volume of the pulse is  $E^2/4\pi$ , and since this is propagated with a velocity  $c$ , the intensity at any instant is

$$I = \frac{cE^2}{4\pi} = \frac{a^2 e^2}{4\pi r^2 c^3} \frac{\sin^2 \theta}{(1 - \beta \cos \theta)^6}. \quad (2.09)$$

<sup>1</sup> As far as eq. 2.11, this discussion follows closely A. Sommerfeld, *Phys. Zeits.* 10 969 (1919); *Atomic Structure and Spectral Lines*, p. 33 (1923).

The total radiated energy traversing unit area at  $P$  due to stopping the electron is  $S = \int Idt$ , where the integral is taken over the complete pulse. If  $t$  is the time at which the radiation reaches  $P$  which left the electron at the instant  $t'$ , then  $t = t' + r/c$ . Thus  $dt = dt' + dr/c$  where, as a glance at Fig. 23 will show,  $dr = vdt' \cos \theta = \beta c \cos \theta dt'$ , and hence,

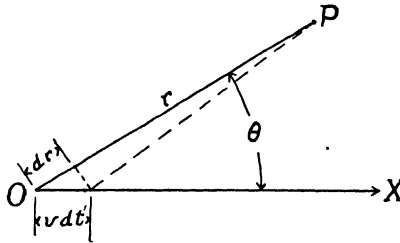

FIG. 23.

$\frac{dt}{dt'} = \frac{1 - \beta \cos \theta}{1 - \beta \cos \theta}$ . But  $a = cd\beta/dt'$ , whence  $dt' = cd\beta/a$ , and  $dt = c/a(1 - \beta \cos \theta)d\beta$ .

Thus

$$\begin{aligned}
 S &= \int Idt = \int_{\beta}^{\beta} \frac{a^2 e^2}{4\pi r^2 c^3} \frac{\sin^2 \theta}{(1 - \beta \cos \theta)^6} \cdot \frac{c}{a} (1 - \beta \cos \theta) d\beta, \\
 &= \frac{ae^2}{4\pi r^2 c^2} \sin^2 \theta \int_{\beta}^{\beta} \frac{d\beta}{(1 - \beta \cos \theta)^5}, \\
 &= \frac{ae^2}{16\pi r^2 c^2} \frac{\sin^2 \theta}{\cos \theta} \left[ \frac{1}{(1 - \beta \cos \theta)^4} - 1 \right]; \quad (2.10)
 \end{aligned}$$

or for small values of  $\beta$ ,

$$S_0 = \frac{ae^2 \beta}{4\pi r^2 c^2} \sin^2 \theta. \quad (2.11)$$

The result of this calculation may be tested both regarding the spatial intensity distribution which it predicts and regarding the absolute value of the predicted X-ray intensity. The energy as a function of the angle  $\theta$  according to equation (2.10) is plotted in Fig. 24 for different values of  $\beta$ . In order to test the theory under most favorable conditions, experiments

using X-rays from thin targets have been performed by Kaye,<sup>1</sup> and using targets of carbon have been done by Stark<sup>2</sup> and Löbe.<sup>3</sup> The reason for using carbon is that with an element of so low an atomic number no appreciable amount of energy goes into the line spectrum, which necessarily consists of trains of waves, instead of pulses. Moreover the absorption of the X-rays by the target is so small that it can be corrected for. Stark's results for X-rays of two different degrees of hardness are shown in Fig. 25.

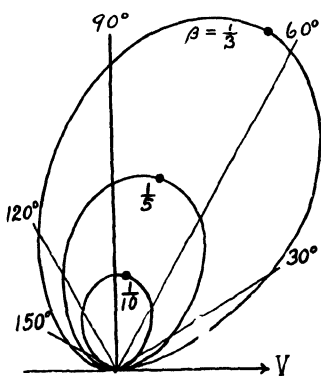

FIG. 24.

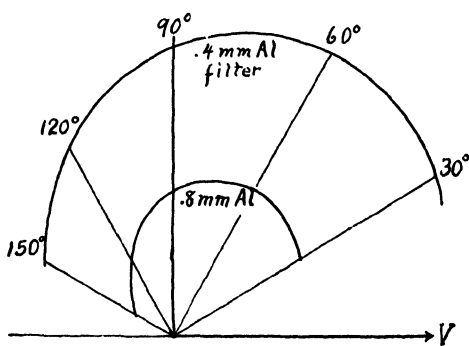

FIG. 25.

There are marked qualitative similarities between the theoretical curves 24 and the experimental data shown in Fig. 25. The intensity seems to approach a minimum at 0 and 180 degrees, as the theory predicts, and the maximum intensity is found to be at an angle less than 90 degrees. It is true that the shapes of the curves are not identical, in that the experimental curve does not approach zero intensity at the angle zero. Such departures from the theory are, however, just what one would anticipate from the known fact that the direction of motion of the electrons is altered as they enter the target. This is well illustrated by the curvature of the  $\beta$ -ray tracks in air as shown in Fig. 4. Moreover, not all of the X-rays are produced when the cathode particles are moving at their maximum speed.

<sup>1</sup> G. W. Kaye, Proc. Camb. Phil. Soc. **15**, 269 (1909).

<sup>2</sup> J. Stark, Phys. Zeits. **10**, 902 (1909).

<sup>3</sup> W. W. Löbe, Ann. d. Phys. **44**, 1033 (1914).

Closely associated with the fact that the intensity of the X-rays is greater at small angles with the stream of cathode rays, is the fact, noticed by Stark,<sup>1</sup> that the absorption coefficient of the X-rays is less at small than at great angles. This is in accord with the fact that the pulse, considered in the discussion leading to equation (2.10), is thinner in the forward than in the backward direction. We may think of this as a kind of Doppler effect, due to the forward motion of the radiating electron. Translating pulse thickness into terms of wave-length, this means that according to Stokes' hypothesis the wave-length of greatest energy should be shorter for the rays going forward than for those going backward. Exactly this type of phenomenon is shown in Wagner's spectra<sup>2</sup> (Fig. 26) of

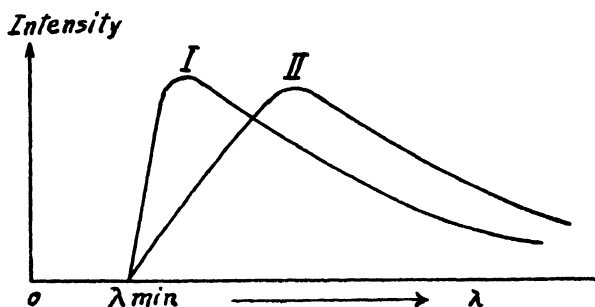

FIG. 26.

the rays emitted in different directions. These experiments show that the wave-length of maximum intensity is very appreciably less for the rays proceeding forward than for those going backward.

*Polarization of Primary X-rays.*—Referring again to Fig. 22 and the discussion leading to equation (2.05), it will be seen that the magnetic field of the X-ray pulse at  $P$  is tangential to the circle  $PSQ$ , and if the charge  $e$  is negative, the electric field at  $P$  is in the direction  $PE$ , perpendicular both to  $PH$  and  $OP$ . The pulse is thus completely plane polarized.

<sup>1</sup> J. Stark, loc. cit.

<sup>2</sup> E. Wagner, *J. d. Rad. Elek.* 16, p. 212, Dec. 1919. For a full discussion of this matter, see D. L. Webster, *Bull. N. R. C.*, No. 7, p. 442 (1920).

Polarization of primary X-rays was first observed by Barkla,<sup>1</sup> using the apparatus shown diagrammatically in Fig. 27. The method consisted essentially in using for the analyzer a screen of paper which scattered the ray at 90 degrees and in observing the effect of rotating the X-ray tube. He found that the ionization chamber which received the scattered ray proceeding at right angles to the cathode rays registered the greater current by 10 or 20 per cent. These results have been extended by Haga,<sup>2</sup> Herweg,<sup>3</sup> Bassler,<sup>4</sup> and Vegard.<sup>5</sup> It is found that by filtering out the softer components of the

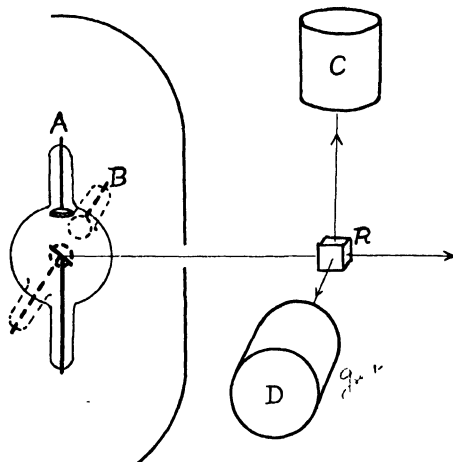

FIG. 27.

primary beam the polarization can be increased, though increasing the speed of the cathode rays seems to diminish the effect.

These experimental results coincide in detail with the predictions of the pulse theory if we keep in mind the fact that most of the cathodic electrons have their direction of motion

<sup>1</sup> C. G. Barkla, *Nature*, Mar. 17, 1904; Mar. 9, 1905; *Phil. Trans. Roy. Soc.* **204**, 467 (1905).

<sup>2</sup> H. Haga, *Ann. der Phys.* **23**, 439 (1907).

<sup>3</sup> J. Herweg, *Ann. der Phys.* **29**, 398 (1909).

<sup>4</sup> E. Bassler, *Ann. der Phys.* **28**, 808 (1909).

<sup>5</sup> L. Vegard, *Proc. Roy. Soc.* **83**, 379 (1910).

altered before they produce X-rays, and that the softer X-rays are presumably produced by electrons near the end of their range, and which therefore are less likely to be moving in the initial direction.

The efficiency of the production of X-rays by this process can be calculated if we can determine the acceleration  $a$  with which the electron is brought to rest. An approximate method of doing this is to compare the spectral energy distribution curve for a pulse with the experimental energy distribution observed for X-rays excited by cathode rays of definite energy. Let us suppose, as Stokes's theory suggests, that the pulse is uni-

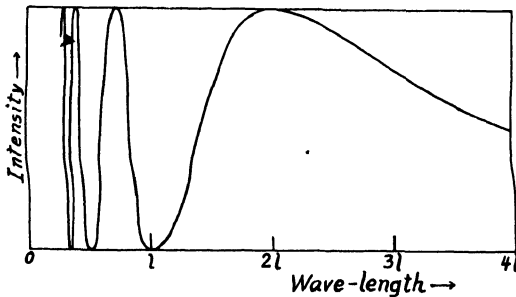

FIG. 28.

directional, the electric field being of strength  $E$  for a time  $\delta t$ , so that the pulse is of thickness  $l = C\delta t$ . It can then be shown, by expressing the pulse as a Fourier integral (see Appendix II), that it is equivalent to a continuous spectrum of radiation whose intensity between wave-length  $\lambda$  and  $\lambda + d\lambda$  is

$$I\lambda d\lambda = K \cdot \sin^2 \pi \frac{l}{\lambda} d\lambda. \quad (2.12)$$

A graph of this function is shown in Fig. 28. It will be seen that the intensity is a maximum for  $\lambda = 2l, \frac{2}{3}l, \frac{2}{5}l$ , etc.

If we neglect the smaller peaks and consider only the portion of the curve for wave-lengths greater than  $l$ , this curve is rather similar to those shown in Fig. 20, representing the spectrum excited by a constant potential. According to the experimental curves, the wave-length of maximum energy

density is about  $4/3$  times the minimum wave-length. We may thus say approximately that

$$\frac{4}{3} \frac{hc}{Ve} = 2l,$$

or

$$l = \frac{2}{3} \frac{hc}{Ve}. \quad (2.13)$$

The radiated energy may now be calculated from equation (2.06) by placing  $\delta r = l$ , and noting that  $a = v/\delta t = vc/l$ , whence

$$\begin{aligned} W &= \frac{2}{3} \frac{e^2 l}{c^4} \cdot \frac{v^2 c^2}{l^2} = \frac{2}{3} \frac{e^2 v^2}{c^2 l} \\ &= \frac{2}{3} \frac{e^2}{c^2 v^2} \cdot \frac{3}{2} \frac{Ve}{hc} \\ &= \frac{v^2}{hc^3} Ve^3 \end{aligned}$$

by equation (2.13). Since the energy of the electron producing the  $x$ -rays is  $Ve$ , the efficiency of their production is

$$\epsilon = \frac{v^2 e^2}{hc^3}.$$

Since  $\frac{1}{2}mv^2 = Ve$  (approx.), or  $v^2 = 2Ve/m$ , the efficiency may be written as

$$\epsilon = 2 \frac{Ve^3}{mhc^3}. \quad (2.14)$$

An experimental investigation by Beatty,<sup>1</sup> has shown that the efficiency of production of X-rays may be expressed by the formula,

$$\epsilon_{\text{expt.}} = 2.5 \times 10^{-4} A\beta^2,$$

where  $A$  is the atomic weight of the target of the X-ray tube and  $\beta c$  is the velocity of the electrons as they strike the target.

<sup>1</sup> R. T. Beatty, Proc. Roy. Soc. A. **89**, 314 (1913).

Writing  $\frac{1}{2}mv^2 = \frac{1}{2}m\beta^2c^2 = Ve$ , whence  $\beta^2 = 2Ve/mc^2$ , this empirical result becomes,

$$\epsilon_{\text{expt.}} = 5 \times 10^{-4} \frac{AeV}{mc^2}. \quad (2.15)$$

A comparison of this result with equation (2.14) shows that experiments confirm the prediction of the pulse theory that the efficiency of X-ray production is proportional to the potential  $V$  applied to the X-ray tube. We find, however, that the efficiency depends, through the atomic weight, upon the nature of the target, a result not anticipated from the formula. Equating (2.14) and (2.15) we find that if

$$A = \frac{2}{5} \times 10^4 \frac{e^2}{hc} = 4.6$$

the calculated value of the efficiency is equal to the observed value. Our calculation is thus inadequate because it fails to take account of the increase in efficiency with the atomic number of the radiator. It will probably be unprofitable to study the matter further from the present standpoint, since there is convincing evidence that the hypothesis of X-ray pulses is incorrect. It is, however, an interesting fact that the efficiency calculated on this basis varies in the proper manner with the potential and that its absolute value is not far from the proper order of magnitude.

#### 14. *Difficulties with the Pulse Hypothesis*

In spite of these qualitative successes of the pulse theory of X-rays, an examination of X-ray spectra shows that any form of pulse hypothesis is untenable. For if such pulses are reflected from a crystal grating, the reflection should occur over a wide range of angles. Thus we have seen in Fig. 28 the spectral energy distribution which is equivalent to a simple rectangular pulse. Other forms of pulses result in different distributions, but it can be shown that every pulse of finite length is equivalent to a continuous distribution of energy over the complete

spectrum from zero to infinite wave-lengths. This is definitely at variance with the experimental fact that the continuous spectrum of X-rays has a sharp short wave-length limit.<sup>1</sup> In order to give such a sharp limit to the spectrum, it is necessary that a large number of waves should follow each other at regular intervals, so that a small change in the angle of reflection from the crystal grating will make the last wave of the train differ in phase sufficiently from the first to produce interference. It follows that X-rays are not, as Stokes supposed, short, irregular, electromagnetic pulses, but must consist of comparatively long trains of waves.

When we adopt this point of view, however, new difficulties arise in accounting for properties of the X-rays which were described satisfactorily by the pulse hypothesis. According to the electromagnetic theory, a long train of waves can only be radiated by an oscillator which executes a large number of accurately timed vibrations. There is no way in which the cathode electron can do this as it moves at random among the atoms of the target. We must therefore attribute the radiation forming the continuous spectrum as well as that in the X-ray line spectrum to electrons oscillating about *atomic* centers. It is possible to suppose that the directions of such oscillations should preponderate in the direction of motion of the exciting cathode electron, as would be necessary to account for the partial polarization of the X-rays. In order, however, to account for the shorter effective wave-length of the X-rays in the direction of motion of the cathode rays than in the reverse direction, and for the asymmetry of the intensity as illustrated in Fig. 25, it is necessary to suppose that the radiating electron is moving forward with a speed comparable with that of light. Only a kind of Doppler effect can account for these asymmetries of wave-length and intensity. But we cannot suppose that oscillating atoms are moving with the required velocity, for the energy  $\mathcal{V}e$  of a cathode particle, even if all imparted to a single atom, would give to it only a negligible fraction of the velocity of light.

<sup>1</sup> Cf. D. L. Webster, Phys. Rev. 6, 56 (1915).

In order to escape from this dilemma, Webster<sup>1</sup> has suggested that the cathode electron carries with itself a mechanism which is set into oscillation as it traverses matter. Thus the cathode electrons would be moving radiators while they are passing among the atoms of the target. At one time there appeared to be several lines of confirmatory evidence<sup>2</sup> for the view that the electron might have a suitable structure for executing such oscillations. This auxiliary evidence has recently, however, almost completely fallen to the ground,<sup>3</sup> and one hesitates to postulate such a complex structure for the electron for which no other use is found.

As the situation stands, therefore, the sharp limit of the continuous X-ray spectrum means that the X-rays come in long trains of waves. The asymmetry of wave-length and intensity of the X-rays requires us to suppose, however, that the oscillators radiating these waves are moving forward with a velocity approaching that of light. In the absence of any known oscillator which can move with such a velocity, we can only conclude that it does not seem possible on the basis of the usual electron theory and electrodynamics to account adequately for the production of X-rays.

We shall see (Chapter XII) that it is possible to arrive at a solution of this problem on the basis of the idea of radiation quanta which is somewhat more satisfactory.

### 15. *Characteristic Radiations Producing Line Spectra*

From what has been said regarding the significance of the sharp limits to the wave-length of the continuous portion of the X-ray spectrum, it will be obvious that the line spectrum of the characteristic part of the radiation can also be produced only by long trains of waves. The difficulties connected with ascribing the continuous spectrum to long wave trains do not

<sup>1</sup> D. L. Webster, *Phys. Rev.* **13**, 303 (1919).

<sup>2</sup> D. L. Webster, *Bull. Nat. Res. Council No. 7*, p. 453 (1920). A. H. Compton, *Phys. Rev.* **14**, 20 and 247 (1919). A. L. Parson, *Smithsonian Miscellaneous Collections*, **65** (1915).

<sup>3</sup> A. H. Compton, *Phys. Rev.* **21**, 483 (1923).

apply to the characteristic radiations. For experiment shows that this part of the radiation is unpolarized, and when corrections are made for absorption in the target, is uniformly distributed in all directions. The wave-length of the lines is also the same in all directions, showing that the oscillators producing the radiation are not moving with appreciable velocity. There is thus no difficulty with the view that electrons associated with atoms of the target constitute the radiators emitting the characteristic line radiations.

### 16. Energy and Intensity of Long Wave Trains

Let us then imagine that an electron in the target of the X-ray tube is executing simple harmonic motion in such a manner that its displacement in some direction  $z$  is  $z = A \cos (pt' + \delta)$ , where  $A$  is the amplitude of the oscillation,  $p = 2\pi\nu$ ,  $\nu$  being the frequency and  $\delta$  the phase of the motion when  $t' = 0$ . The electron's acceleration will then be

$$a = \frac{d^2z}{dt'^2} = -Ap^2 \cos (pt' + \delta).$$

This motion will produce an electromagnetic disturbance which will arrive at a point  $P(r, \theta)$ , Fig. 29, after a time  $r/c$ . The phase of the wave at this point at a time  $t$  is accordingly that of the wave which left the electron at the instant  $t' = t - r/c$ . But the acceleration of the electron at that instant is

$$a = -Ap^2 \cos \left\{ p \left( t - \frac{r}{c} \right) + \delta \right\}.$$

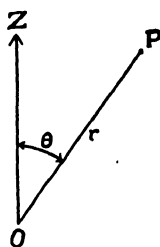

FIG. 29.

By the equation (2.05), the electric intensity of the wave at the time  $t$  is therefore

$$E = \frac{e \sin \theta}{rc^2} Ap^2 \cos \left\{ p \left( t - \frac{r}{c} \right) + \delta \right\}. \quad (2.16)$$

At a distance  $r = ct$  the phase of the disturbance expressed by (2.16) would be constant. This means that the equation

represents a wave propagated from the electron with the velocity  $c$ .

The rate at which energy is radiated by the oscillating electron, by equation (2.07), is

$$\frac{dW}{dt} = \frac{2}{3} \frac{e^2}{c^3} A^2 p^4 \cos^2 \left\{ p \left( t - \frac{r}{c} \right) + \delta \right\}.$$

To obtain the average rate of energy emission, we may integrate this expression over a complete oscillation, thus:

$$\begin{aligned} \frac{\overline{dW}}{dt} &= \frac{\int_{t=0}^{t=2\pi/p} dW}{2\pi/p} = \frac{p}{2\pi} \int_0^{2\pi/p} \frac{2}{3} \frac{e^2 A^2 p^4}{c^3} \cos^2 \left\{ p \left( t - \frac{r}{c} \right) + \delta \right\} dt \\ &= \frac{p}{2\pi} \cdot \frac{2\pi}{3} \frac{e^2 A^2 p^3}{c^3} = \frac{1}{3} \frac{e^2}{c^3} A^2 p^4. \end{aligned} \quad (2.17)$$

The energy per unit volume of the wave is as before  $E^2/4\pi$ . When this is averaged over a complete cycle, since the average value of  $\cos^2 x$  between  $x = 0$  and  $x = 2\pi$  is  $\frac{1}{2}$ , we obtain from (2.17) the average energy per unit volume of the wave as

$$(2.16) \quad \frac{e^2 \sin^2 \theta}{8\pi r^2 c^4} A^2 p^4.$$

The energy passing unit area per second is  $c$  times this quantity, being

$$I = \frac{e^2 A^2 p^4}{8\pi r^2 c^3} \sin^2 \theta. \quad (2.18)$$

### 17. Width of Spectrum Lines Due to Damping of Electron's Motion by Radiation

Though, as we have seen, the high degree of sharpness of X-ray spectrum lines indicates that they come in long trains of waves, the very fact that the radiating electron is losing energy requires that the length of the wave-train shall be finite. If we suppose, as has been assumed above, that it is a single electron in simple harmonic motion which gives rise to the radiation, we can calculate the rate at which its motion is damped by its own

radiation. The energy (kinetic plus potential) of the oscillation is  $\frac{1}{2}mv^2_{\max}$ , or  $\frac{1}{2}m.A^2p^2$ . According to equation (2.17) the fraction of the oscillator's energy which is lost per second is thus

$$-\frac{dW}{Wdt} = \frac{1}{3} \frac{e^2}{c^3} \frac{A^2 p^4}{\frac{1}{2}m.A^2 p^2} = \frac{2}{3} \frac{e^2 p^2}{mc^3}$$

On solving this differential equation, we find

$$W = W_0 e^{-2kt}, \tag{2.19}$$

where

$$k \equiv \frac{1}{3} \frac{e^2 p^2}{mc^3} = \frac{4\pi^2}{3} \frac{e^3}{mc\lambda^2} \tag{2.20}$$

But since  $W = \frac{1}{2}m.A^2 p^2$ , it follows that

$$A = A_0 e^{-kt}. \tag{2.21}$$

Thus  $k$  is the rate at which the amplitude decreases per second. The rate of decrease per wave-length is  $k/\nu$ ,  $\nu$  being the number of waves per second.

According to equation (2.20), an oscillator should have its amplitude reduced to  $1/e$  of its initial value in the number of vibrations given in the second column of table II-1. It will be seen that this number is inversely proportional to the wave-length, so that the damping of an electron radiating X-rays is much more important than that of an electron radiating light.

TABLE II-1  
DAMPING OF WAVES DUE TO RADIATION

Wave-length Ångströms	Effective No. of Waves in Train, $\nu/k$	Effective Length of Wave-train, cm., $c/k$
.01 (hard $\gamma$ -rays) . . . . .	27	$2.7 \times 10^{-9}$
.5 (x-rays) . . . . .	1,350	$6.75 \times 10^{-6}$
5000 (light) . . . . .	$1.35 \times 10^7$	$6.75 \times 10^2$

Unless a wave-train is of infinite length, it must appear in the spectroscopie as a continuous band which shades from a maximum intensity at the center gradually to zero at either side.

We may define the effective breadth of the band as its breadth where the intensity is half that in the center. It has been shown by a Fourier analysis<sup>1</sup> that a wave damped according to equation (2.21) has a breadth of

$$\Delta\lambda = \frac{k\lambda^2}{\pi c},$$

or by equation (2-20),

$$\begin{aligned}\Delta\lambda &= \frac{4\pi}{3} \frac{e^2}{mc^2} \\ &= .00012\text{A}.\end{aligned}$$

The width due to damping is thus independent of the wavelength.

Experiments show that X-ray spectrum lines do have a perceptible width, which is, at least in some cases, greater than this calculation would indicate.<sup>2</sup> It is of course possible that other factors than damping of the electron's oscillations due to radiation contribute to the width of these lines.

### 18. *Minimum Wave-length of a Spectral Line*

It will be seen from Table II-1 that as the wave-length becomes shorter the oscillations become more strongly damped. When the damping becomes so great that  $k > p$ , oscillations of the electron can no longer occur. Any displacement is instead gradually reduced to zero. An approximate calculation indicates that the maximum possible frequency of oscillation of an electron which is thus damped by its own radiation is given by

$$p_{\max.} = \frac{3}{2} \frac{mc^3}{e^2},$$

which corresponds to the wave-length,

$$\begin{aligned}\lambda_{\min.} &= \frac{4\pi}{3} \frac{e^2}{mc^2} \\ &= .00012\text{A}.\end{aligned}$$

<sup>1</sup> G. E. M. Jauncey, Phys. Rev. 19, 64 (1922).

<sup>2</sup> A. H. Compton, Phys. Rev. 19, 68 (1922).

This minimum wave-length is not much shorter than the wave-length  $.00038\text{\AA}$  estimated by Millikan<sup>1</sup> for the most penetrating cosmic rays. For radiation of the wave-length  $.00038\text{\AA}$ , we have  $\nu/k = 1$ , which means, as in Table II-1, that there is effectively only 1 wave in the train.

<sup>1</sup>R. A. Millikan, Proc. Nat. Acad. 12, 48 (1926).

## CHAPTER III

### THE SCATTERING OF X-RAYS

#### 19. Thomson's Theory of Scattering by Independent Electrons

One of the most important consequences of the electromagnetic theory of X-radiation is the fact that by its help we can predict the intensity and the general characteristics of scattered X-rays. We noticed in the first chapter that if X-rays are electromagnetic waves they should set into forced oscillation the electrons which they traverse, and these electrons in virtue of their accelerations should themselves radiate energy. If we suppose that the electrons in the scattering material are not subject to any appreciable forces of constraint, and if they are arranged in such a random manner that no definite phase relations exist between the rays scattered by the different electrons, we can calculate very simply the intensity of the scattered beam.<sup>1</sup>

If a wave whose electric intensity is  $E$  traverses an electron of charge  $e$  and mass  $m$ , the acceleration of the electron is  $Ee/m$ . According to equation (2.05) this electron will radiate a wave whose electric intensity at a distance  $r$  is

$$E_{\theta} = - \frac{e \sin \theta}{rc^2} \cdot \frac{Ee}{m} = - \frac{Ee^2 \sin \theta}{rmc^2},$$

where  $\theta$  is the angle between the electron's acceleration and the ray which we are considering. Since the intensities of both the primary and the secondary rays are proportional to the square of their electric vectors, the ratio of their intensities is

$$\frac{I_{\theta}}{I} = \frac{E_{\theta}^2}{E^2} = \frac{e^4 \sin^2 \theta}{r^2 m^2 c^4}. \quad (3.01)$$

<sup>1</sup> This calculation follows in principle, though not in detail, that performed by J. J. Thomson, "Conduction of Electricity through Gases," 2d Ed., p. 325.

If the primary ray is unpolarized, the acceleration of the scattering electron will be in a random direction in a plane perpendicular to the primary beam,  $OX$ , Fig. 30. Let us take two rectangular axes in this plane,  $OY$  and  $OZ$ , such that one of them  $OY$  is in the plane  $POX$  in which lies the scattered ray which we are studying. The electric vector of the primary ray may be resolved into two components,  $E_y$  and  $E_z$ , such that  $E_y^2 + E_z^2 = E^2$ . Since the direction of  $E$  in the  $YOZ$  plane is

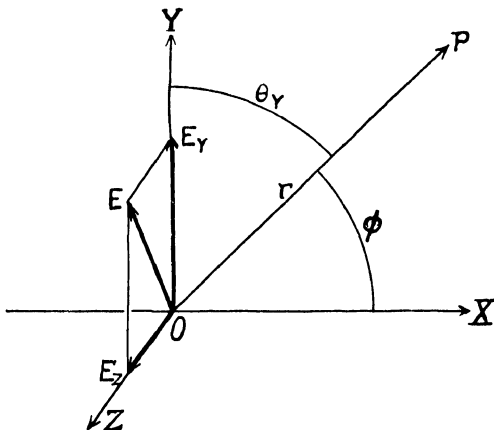

FIG. 30.

random,  $E_y$  is on the average equal to  $E_z$ , whence on the average,

$$E_y^2 = E_z^2 = \frac{1}{2}E^2.$$

Thus

$$I_y = I_z = \frac{1}{2}I,$$

where  $I_y$  and  $I_z$  represent the intensities of the  $Y$  and  $Z$  components of the primary beam. The intensity of the scattered beam at  $P$  due to the  $Y$  component of the incident ray is, by equation (3.01),

$$I_{\theta y} = I_y \frac{e^4 \sin^2 \theta_y}{r^2 m^2 c^4},$$

or

$$I_{\phi y} = \frac{1}{2}I \frac{e^4}{r^2 m^2 c^4} \cos^2 \phi, \tag{3.02}$$

where  $\phi$  is the angle between the primary and the scattered rays. Similarly, that due to the  $Z$  component is

$$\begin{aligned} I_{\phi z} &= I_z \frac{e^4 \sin^2 \theta_z}{r^2 m^2 c^4} \\ &= \frac{1}{2} I \frac{e^4}{r^2 m^2 c^4}, \end{aligned} \quad (3.03)$$

since  $\theta_z = \pi/2$ . Thus if the primary beam is unpolarized, the intensity of the beam scattered by a single electron is

$$\begin{aligned} I_c &= I_{\theta Y} + I_{\theta z} \\ &= I \frac{e^4}{2r^2 m^2 c^4} (1 + \cos^2 \phi). \end{aligned} \quad (3.04)$$

If a number  $n$  of electrons are independently effective in scattering, the intensity of the scattered beam is then

$$I_s = \frac{Ine^4}{2r^2 m^2 c^4} (1 + \cos^2 \phi). \quad (3.05)$$

The calculation of the total energy in the scattered beam is effected most directly by integrating equation (3.05) over the surface of a sphere of radius  $r$ , thus:

$$\begin{aligned} W_s &= \int_0^\pi I_s \cdot 2\pi r \sin \phi \cdot r d\phi \\ &= \frac{\pi Ine^4}{m^2 c^4} \int_0^\pi (1 + \cos^2 \phi) \sin \phi d\phi \\ &= \frac{8\pi}{3} \frac{ne^4}{m^2 c^4} I. \end{aligned}$$

If  $n$  represents the number of electrons in a cubic centimeter, since  $I$  is the energy in the primary beam per square centimeter per second, the fraction of the primary energy which is scattered per cm. path is

$$\sigma = \frac{W_s}{I} = \frac{8\pi ne^4}{3m^2 c^4}. \quad (3.06)$$

This quantity  $\sigma$  is called the *scattering coefficient*.

It is worth noting that these results have been obtained without assuming any particular form of electromagnetic pulse. They are thus independent of the wave-length and of the degree of homogeneity of the X-rays. The only unknown quantity which enters into these equations is the number of electrons  $n$  which is effective in the scattering. An experimental measurement of the scattering coefficient  $\sigma$  will thus enable us to determine this number.

### 20. *Determination of the Number of Electrons per Atom*

In the case of carbon, Hewlett has measured the intensity of the scattered X-rays over angles extending almost from  $\phi = 0$  to  $\phi = 180$ , so that he was able to perform experimentally the integration required to obtain  $\sigma$ . He thus finds<sup>1</sup> for the mass scattering coefficient  $\sigma/\rho$ , the value 0.20. That is, about 20 per cent of the primary X-rays (of effective wave-length 0.71A in Hewlett's experiments) are scattered as the X-rays traverse a layer of carbon 1 cm.<sup>2</sup> cross section and of mass 1 gram. According to equation (3.06) the number of effective electrons per gram of carbon is

$$\frac{n}{\rho} = \frac{\sigma}{\rho} \cdot \frac{3m^2c^4}{8\pi e^4}.$$

Taking  $\sigma/\rho = 0.20$ , and using the usual values of  $e$ ,  $m$  and  $c$  (cf. Appendix III), this gives

$$\frac{n}{\rho} = 3.0 \times 10^{23} \text{ electrons per gram.}$$

But the number of carbon atoms per gram is

$$\frac{N}{A} = 6.06 \times \frac{10^{23}}{12} = 5.05 \times 10^{22} \text{ atoms per gram,}$$

where  $N$  is the number of molecules per gram molecule and  $A$  is the atomic weight of carbon. Thus the number of electrons per atom which scatter X-rays is  $3.0 \times 10^{23}/5.05 \times 10^{22} = 6.0$ , which is the atomic number of carbon.

<sup>1</sup> C. W. Hewlett, *Phys. Rev.* **19**, 266 (1922); **20**, 688 (Dec. 1922).

On comparing this result with the conclusions drawn from Bohr's theory (p.I.37), we see that this means that all of the electrons exterior to the nucleus of the atom are effective in scattering X-rays. The reasonableness of this result lends strong support to the present theory of X-ray scattering. Historically, an experiment of this type performed by Barkla afforded our first accurate estimate of the number of mobile electrons in the atom.<sup>1</sup>

In making this determination of the number of electrons effective in scattering X-rays, it is fortunate that Hewlett and Barkla used X-rays of moderately great wave-length. For, although according to the theory just given the scattering coefficient should be independent of the wave-length, experiment shows a considerable variation with wave-length of the fraction of the X-rays that is scattered.

### 21. *Hard X-rays Scattered Less than Predicted*

A typical experiment showing this variation is that performed by Hewlett on the absorption of X-rays in carbon. Since the quantity  $\sigma$  represents energy transferred from the primary to the scattered beam, it corresponds to a kind of absorption coefficient. There is, of course, energy removed from the primary beam by other processes, such as the production of photo-electrons. We may thus write for the total absorption coefficient,

$$\mu = \tau + \sigma, \quad (3.07)$$

where  $\mu$  has the same significance as in equation (1.01),  $\sigma$  represents the energy dissipated in scattering, and  $\tau$  the energy lost by other methods.

In the case of short wave-length X-rays traversing elements of low atomic number, it is found that the quantity  $\tau$  becomes small, so that an approximate estimate of the scattering coefficient  $\sigma$  can be made from such absorption measurements. Hewlett<sup>2</sup> has measured the mass absorption coefficients of

<sup>1</sup> C. B. Barkla, *Phil. Mag.* **21**, 648 (1911).

<sup>2</sup> C. W. Hewlett, *Phys. Rev.* **17**, 284 (1921).

carbon over a wide range of wave-lengths. His values for wave-lengths less than  $0.5\text{\AA}$  are shown in Fig. 31, which also includes the absorption coefficient of hard  $\gamma$ -rays ( $\lambda = .02\text{\AA}$ ) in carbon. It will be seen that in the neighborhood of  $0.2\text{\AA}$  the total absorption curve is nearly flat, and has nearly the value  $.202$  calculated from equation (3.06). The fact that the total absorption for greater wave-lengths exceeds this value may be explained as due to the increasing value of the absorption  $\tau$ ; but the fact that for short wave-lengths the total absorption falls below the theoretical value of  $\sigma/\rho$  alone has no such explanation.<sup>2</sup> These experiments show that, as the wave-length

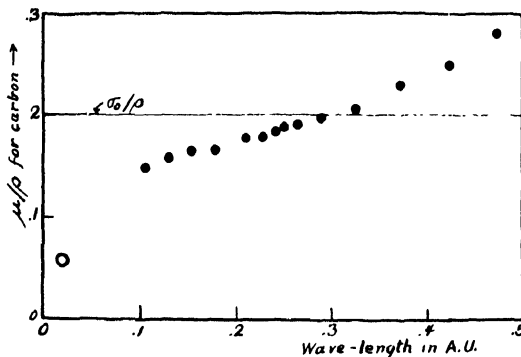

FIG. 31.

of the X-rays becomes shorter and shorter, the intensity of the scattered X-rays falls farther and farther below the value predicted by the present theory.

We shall see later (Chapter IX) that this difficulty can be removed by introducing a form of quantum theory. The introduction of this change will modify considerably our present conclusions regarding the intensity of X-rays of short wave-length, but will alter only slightly these equations when applied to wave-lengths greater than  $0.5\text{\AA}$ .

<sup>2</sup> This inconsistency with the classical theory of scattering was first demonstrated by Barkla and Miss White (Phil. Mag. 34, 270, 1917).

22. *Interference Effects with Heavy Scattering Elements*

When X-rays of relatively great wave-length are used, the experiments show a departure from the theory in the opposite direction. Thus in Fig. 32 are shown data, obtained by Barkla and his collaborators,<sup>1</sup> for the intensity of the rays scattered by

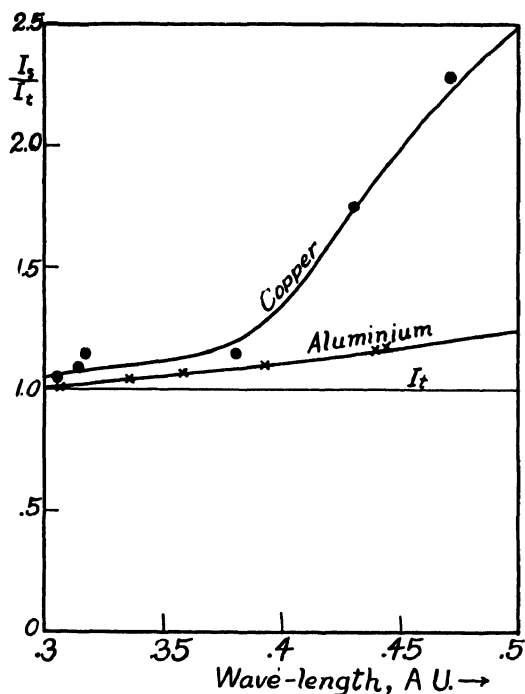

FIG. 32.

aluminum and copper at  $90^\circ$  with the primary beam, when traversed by rays of different wave-length. Whereas, over the range of wave-lengths considered, the scattering by aluminum is very nearly constant, the scattering by copper increases, rapidly for wave-lengths greater than about  $0.4\text{A}$ .

The interpretation of this effect is probably that when the wave-length is long compared with the distances between the

<sup>1</sup> C. G. Barkla and J. C. Dunlop, *Phil. Mag.* **31**, 229 (1916). C. G. Barkla and R. Sale, *Phil. Mag.* **45**, 743 (1923).

electrons in the atoms, the phases of the rays scattered from the different electrons are nearly the same, resulting in an increased total intensity. Indeed, if the distances between the electrons were negligible compared with the wave-length of the X-rays, all the electrons in the atom would act as a unit. If  $Z$  is the number of electrons in the atom, the intensity of the ray scattered by a single atom would then be (equation 3.04).

$$\begin{aligned} I_a' &= I \frac{(Ze)^4}{2r^2(Zm)^2c^4} (1 + \cos^2 \phi) \\ &= \frac{IZ^2e^4}{2r^2m^2c^4} (1 + \cos^2 \phi) = I_e Z^2, \end{aligned} \quad (3.08)$$

whereas if the electrons scatter independently the intensity should be (equation 3.05)

$$I_a = \frac{IZe^4}{2r^2m^2c^4} (1 + \cos^2 \phi) = I_e Z.$$

According to the degree of concentration of the electrons near the center of the atom, the intensity of the scattered X-rays may thus vary by a factor of  $Z$ . The fact that for the light elements the scattering per atom is proportional to the first power of the atomic number, rather than to its square, thus indicates that in these atoms the electrons are spaced at distances which are considerable when measured in terms of X-ray wave-lengths. The fact that for the heavier elements the intensity of the scattering increases more rapidly than the atomic number indicates that in these atoms some of the electrons are close together when measured on this scale.<sup>1</sup>

### 23. *Approximate Validity of $(1 + \cos^2 \phi)$ Rule for Soft X-rays*

An experimental test of equation (3.05), describing the relative intensity at different angles, leads to equally interesting results. In order to satisfy the conditions of the theory as well

<sup>1</sup> According to some recent absorption measurements, the atomic scattering coefficient for heavy elements is more nearly proportional to  $Z^3$  than to  $Z$  (Cf. e.g., S. J. M. Allen, *Phys. Rev.* **24**, 1, 1924).

as possible, we shall consider first the scattering by a liquid, in which the arrangement of the molecules is nearly random, and of low atomic number, in order that the constraining forces on the electrons shall be small. Such a substance is mesitylene ( $C_6H_3(CH_3)_3$ ), whose scattering has been investigated by Hewlett,<sup>1</sup> using an approximately homogeneous beam of wave-

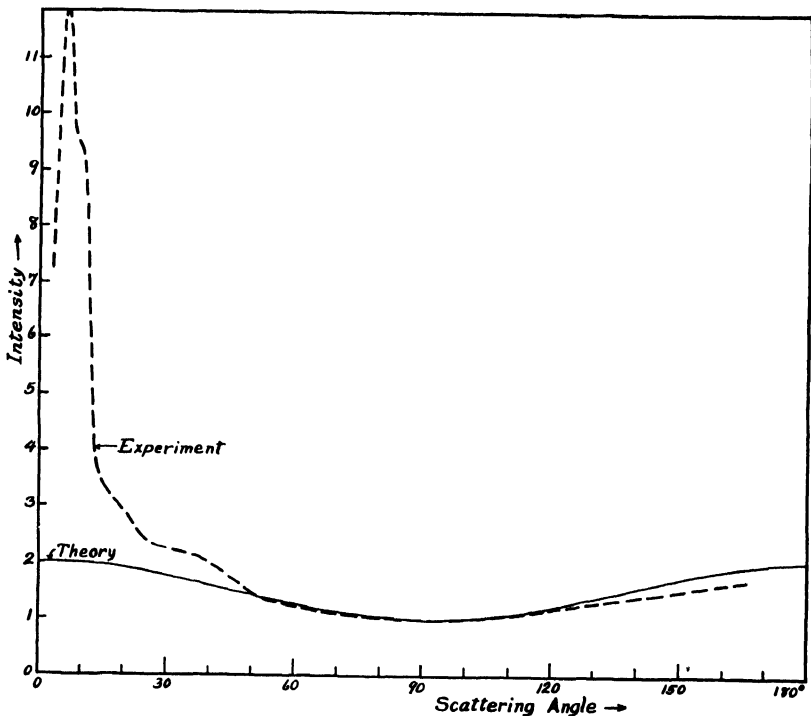

FIG. 33.

length  $0.71\text{\AA}$ . His experimental values of the intensity at various angles are shown in Fig. 33 as a broken line. The solid line shows the calculated value of the intensity, according to equation (3.05). We shall find that the variations from the theoretical curve between the angles  $0^\circ$  and  $30^\circ$  are explicable as due chiefly to the fact that at these small angles interference occurs between the rays scattered by neighboring atoms. The

agreement between the experiments and the theory for angles greater than  $30^\circ$  is however very satisfactory.

#### 24. *Departures from Theory for Hard X-rays*

If the scattering of rays of shorter wave-length is considered, however, the theory departs widely from the experiments. Thus Fig. 34 exhibits the intensity of the scattered radiation from iron at different angles with a primary beam of hard  $\gamma$ -rays

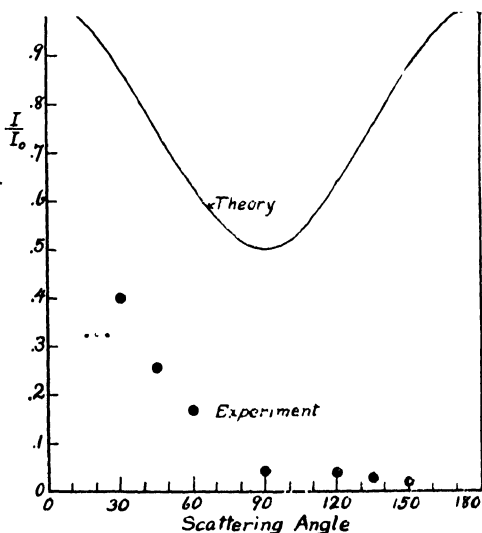

FIG. 34.

from radium *C* ( $\lambda = .02A$ ). Here again the broken line represents the intensity as calculated according to equation (3.05), while the experimental points were determined by the author.<sup>1</sup> Both the theoretical curve and the experimental values are expressed in terms of the theoretical intensity at zero scattering angle,

$$I_0 = I \frac{Ne^4}{r^2 m^2 c^4}$$

<sup>1</sup> A. H. Compton, *Phil. Mag.* 41, 758 (1921) and *Phys. Rev.* May, 483 (1923).

calculated on the assumption that the number of electrons per iron atom, effective in scattering, is equal to the atomic number, 26. These experiments are quite irreconcilable with the theory, though there appears a tendency for the scattering to approach the calculated value at small angles. This discrepancy also seems removable through the introduction of the idea of radiation quanta (Chapter IX).

### 25. *Polarization of Scattered X-rays*

A more satisfactory agreement between experiment and the present theory of X-ray scattering is found in connection with the polarization of the scattered X-rays. We notice that equation (3.02) represents the energy in the component of the scattered ray whose electric vector lies in the plane  $POX$  (Fig. 30) including both the primary and the scattered ray. According to equation (3.02), the intensity of this component is zero at right angles with the primary beam ( $\phi = \pi/2$ ), whereas the oppositely polarized component, equation (3.03), keeps its normal intensity. Thus in this direction the scattered beam should be completely plane polarized.

Such polarization can be detected by scattering again the polarized beam, and comparing the intensity of the scattered beam in two different directions, as already described on page II-10. Barkla, in his classic measurement of the polarization of X-rays,<sup>1</sup> found that at 90 degrees the secondary rays from carbon were approximately 70 per cent polarized. This result has been confirmed by several experimenters.<sup>2</sup>

There are, however, two sources of error in these experiments which have the effect of making the polarization appear incomplete. One of these, whose presence was recognized by Barkla, is the fact that in order to secure sufficient intensity in the beam after being twice scattered, the solid angle subtended by the scattering blocks at the source of X-rays must be very appreciable. The result is that most of the scattering does not occur at exactly 90 degrees, so that neither the polarization nor

<sup>1</sup> C. G. Barkla, Proc. Roy. Soc. 77, 247 (1906).

the analysis of the beam can be complete. The magnitude of this "geometrical error" as calculated in a typical case is of the order of 5 per cent. The second source of error is the multiple scattering at angles other than 90 degrees which occurs in both the polarizing and the analyzing radiators. Recent experiments by Hagenow and the author<sup>1</sup> have shown that when this multiple scattering is eliminated by using very thin radiators, and when the geometrical error allowed for, the polarization of the scattered X-rays is complete within an experimental error of 1 or 2 per cent. The X-rays employed were the complete radia-

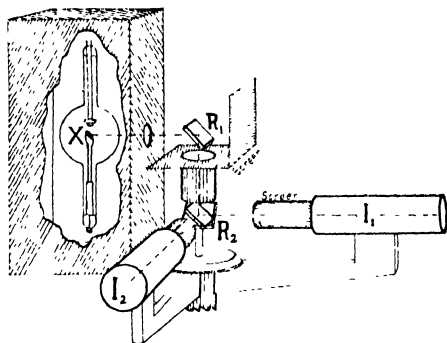

FIG. 35.

tion from a tungsten tube excited at about 130,000 volts, and the test was made on scattering blocks of paper, carbon, aluminum and sulphur. These polarization experiments are therefore in complete accord with the electromagnetic theory of the X-ray scattering.

### 26. *Wave-length of Scattered X-rays*

If the incident beam of X-rays consists of a train of waves of definite frequency, as for example an X-ray spectrum line, the electrons traversed will be set into forced oscillation with the same frequency. Thus, in the special case of a free electron traversed by a wave whose electric field at  $O$  is given by

$$E = E_0 \cos (pt + \delta),$$

<sup>1</sup> A. H. Compton and C. F. Hagenow, J. O. S. A. and R. S. I. 8, p. 487 (1924).

the acceleration of the electron is

$$a = \frac{Ee}{m} = \frac{E_0 e}{m} \cos (pt + \delta).$$

The ray scattered by this electron to a point  $P(r, \theta)$  (Fig. 30) will have an electric field given by the equation

$$\begin{aligned} E_o &= \frac{e \sin \theta}{rc^2} \frac{E_0 e}{m} \cos \left\{ p \left( t - \frac{r}{c} \right) + \delta \right\} & (3.09) \\ &= E_o' \cos (pt + \delta'). \end{aligned}$$

The frequency of this scattered ray is thus the same,  $\nu = p/2\pi$ , as that of the primary ray. It can be shown that the effect of constraints and damping on the motion of the scattering electron is to modify the amplitude and phase of the scattered ray, but not its frequency. The present theory accordingly demands that the two frequencies be identical.

The remark was made in the first chapter that refined measurements show that the wave-length of the scattered X-rays is not identical with that of the primary ray. The result of a typical experiment is shown in Fig. 36.<sup>1</sup>

The upper curve represents the spectrum of the  $K\alpha$  line of molybdenum taken direct from the target. The lower curve represents, on a much larger scale, the spectrum of the same line after being scattered by graphite at  $\phi = 135^\circ$ . A part of the scattered beam has the same wave-length as the primary, but the greater part is of a slightly greater wave-length.

The suggestion at first occurs that the "modified" ray represents a type of fluorescent radiation, and that only the "unmodified" ray is truly scattered. There are, however, strong arguments against this view. In the first place, the wave-length of the modified ray is determined by that of the primary ray and not by the nature of the radiator, contrary to the case of other fluorescent radiation. In the second place, we have seen that the secondary radiation at  $90^\circ$ , which includes the modified ray, is completely polarized; but no form of

<sup>1</sup> A. H. Compton, Phys. Rev. 22, 409 (1923).

fluorescent radiation has ever been shown to be polarized.<sup>1</sup> And finally, so large a part of the secondary energy is in the modified ray that if the intensity of the scattered beam is to be at all comparable in magnitude with that calculated from the electromagnetic theory the modified as well as the unmodified ray must be considered as scattered X-rays.

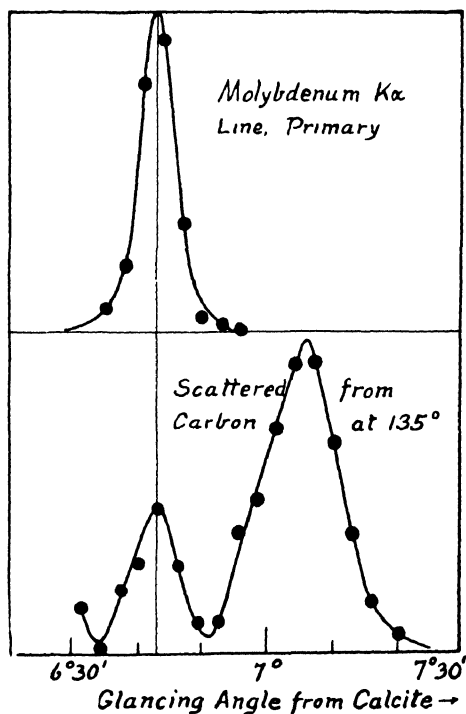

FIG. 36.

We have seen that the electromagnetic theory is inconsistent with the existence of such scattered rays of changed wave-length. We shall, however, find their existence consistent with a quantum theory which supposes that each individual electron,

<sup>1</sup> An apparent exception to this statement occurs in the recent experiments of Wood and Ellet (*Phys. Rev.* **24**, 243, 1924) in which the resonance radiation excited in mercury vapor by polarized radiation from a mercury arc is found to be partially polarized. It is doubtful, however, whether such radiation can properly be classed as fluorescent, since both the primary and secondary rays are of the same wave-length.

if it scatters at all, scatters a whole quantum of X-radiation. If this view is correct, no interference can have occurred in scattering the modified ray, since each quantum of this ray has been scattered by a single electron. But it is consistent with this view to suppose that the unmodified ray is due to quanta that are scattered simultaneously by a group of electrons. In support of this suggestion, it is found that the rays reflected by crystals, which since interference is present must be rays scattered by many electrons, have their wave-length unmodified. It appears, therefore, that the classical electromagnetic theory can be applied to the problem of X-ray scattering only with great caution. When interference is found to occur, it appears at the present writing that the classical theory is applicable; but we do not yet know how to predict under what circumstances interference will occur.

### 27. Theoretical Formulas of Debye and Others

From these considerations we see that it is very important to investigate the interference of the X-rays scattered by groups of electrons. We wish to see in how far the classical theory of interference can account for the experiments on the scattering of X-rays. The simplest problem of this type, which is at the same time representative of the more general problem, is that of the scattering by 2 electrons at a distance  $s$  apart. A solution of this problem is given in Appendix IV. If the incident rays are unpolarized, the average intensity of the ray scattered at an angle  $\phi$  with the primary beam, is found to be

$$I_{\phi} = 2I_e \left( 1 + \frac{\sin x}{x} \right), \quad (3.10)$$

where, as in equation (3.04),

$$I_e = \frac{Ie^4}{2r^2m^2c^4} (1 + \cos^2 \phi),$$

and

$$x \equiv \frac{4\pi s}{\lambda} \sin \frac{\phi}{2}. \quad (3.11)$$

According to this result, if  $x$  is small, that is, for great wavelengths, small distances between the electrons, or small angles of scattering, the intensity of the scattered ray approaches a value 4 times that for a single electron. If, however,  $x$  is large,  $\sin x/x$  becomes small, and the intensity approaches 2 times that due to a single electron—in other words, the electrons scatter independently of each other. The manner in which  $I_\phi/I_e$  varies with the value of  $x$  is shown in Fig. 37. It will be seen that the value of  $I_\phi/I_e$  approaches its final value of 2 by a series of oscillations in intensity.

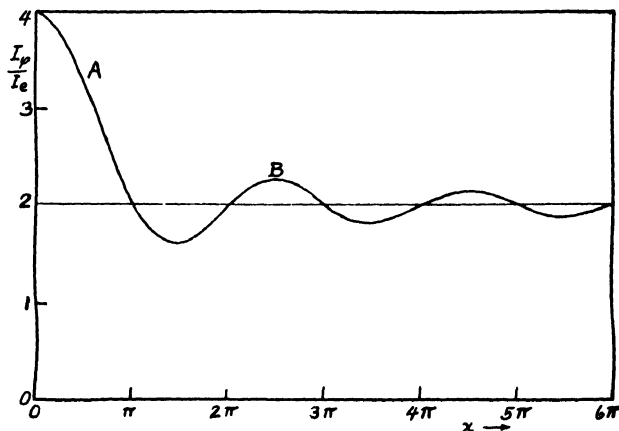

FIG. 37.

If in the hydrogen and helium molecules there exist 2 electrons whose distance apart remains constant,<sup>1</sup> this diagram should represent the intensity of the scattering by these substances for different values of  $x$ . If the position of the minimum near  $x = 3\pi/2$  and the maximum near  $x = 5\pi/2$  could be observed, we should be able to calculate the distance between the electrons in the molecule. Thus, using the copper  $K_\alpha$  ray,  $\lambda = 1.54\text{A}$ , if the electrons in the hydrogen molecule are  $1.1 \times 10^{-8}$  cm. apart, as predicted by an old form of Bohr's theory, the minimum at  $x = \frac{3}{2}\pi$  should occur at a scattering angle of

<sup>1</sup> According to present theories of atomic structure, the distance between the electrons in helium and hydrogen does *not* remain constant.

$\phi = 30^\circ$ , and the maximum at  $x = \frac{5}{2}\pi$  should be at  $\phi = 51^\circ$ . Experiments to test this prediction regarding the scattering by hydrogen and helium have not been performed.

The suggestion that the electrons in the heavy elements cooperate in their scattering seems to have been made first by Webster,<sup>1</sup> and was first stated in a satisfactory form by Darwin,<sup>2</sup> Debye<sup>3</sup> and Thomson<sup>4</sup> have solved independently the problem of the scattering of X-rays by atoms (or groups of atoms) consisting of electrons arranged at fixed distances from each other, taking into account the phases of the rays scattered by the different electrons. Their result may be put in the form,

$$I_\phi = I_e \sum_{m=1}^Z \sum_{n=1}^Z \frac{\sin\left(\frac{4\pi s_{mn}}{\lambda} \sin \frac{\phi}{2}\right)}{\frac{4\pi \cdot s_{mn}}{\lambda} \sin \frac{\phi}{2}} \quad (3-12)$$

Here, as before,  $I_e$  is the intensity of the ray scattered at an angle  $\phi$  by a single electron,  $Z$  is the number of electrons in the group, and  $s_{mn}$  is the distance from the  $m$ th to the  $n$ th electron. It will be noticed that when  $Z = 2$ , this expression becomes identical with equation (3.10).

The more general problem of scattering by atoms composed of electrons in relative motion was investigated by Schott<sup>5</sup> with unsatisfactory results.<sup>6</sup> Glocker and Kaupp,<sup>7</sup> however, have calculated the scattering by atoms composed of two or three coplanar circular rings of electrons revolving at different speeds. Glocker<sup>8</sup> has also calculated the scattering from Lande's pulsating tetrahedral carbon atom, and finds a result practically the same as that for Bohr's plane carbon atom. This is in

<sup>1</sup> D. I. Webster, *Phil.* **25**, 234 (1913).

<sup>2</sup> C. G. Darwin, *Phil. Mag.* **27**, 325 (1914).

<sup>3</sup> P. Debye, *Ann. d. Phys.* **46**, 809 (1915).

<sup>4</sup> J. J. Thomson, manuscript read before the Royal Institution in 1916, and loaned to the writer.

<sup>5</sup> G. A. Schott, *Proc. Roy. Soc.*, **96**, 695 (1920).

<sup>6</sup> Cf. A. H. Compton, *Washington University Studies*, **8**, 98 (1921).

<sup>7</sup> R. Glocker and M. Kaupp, *Ann. d. Phys.*, **64**, 541 (1921).

<sup>8</sup> R. Glocker, *Zeitschr. f. Phys.*, **5**, 54 (May 10, 1921).

agreement with the conclusion that the author had reached,<sup>1</sup> that the scattering by groups of electrons in the atom depends chiefly upon the distance of the electrons from the center of the group and only slightly upon their spatial distribution. I accordingly calculated the intensity of the scattering on the assumption that the electrons are arranged in pairs at opposite sides of spherical shells of radii  $\rho_s$ , the axes of the pairs of electrons having random orientation. On this basis the intensity of the beam scattered by an atom is,<sup>2</sup>

$$I_\phi = I_0 \left\{ Z + 2 \sum_1^{Z/2} \left( \frac{\sin 2k_s}{2k_s} - 2 \frac{\sin^2 k_s}{k_s^2} \right) + 4 \left( \sum_1^{Z/2} \frac{\sin k_s}{k_s} \right)^2 \right\}, \quad (3.13)$$

where  $Z$  is again the number of electrons per atom, and

$$k_s = \frac{4\pi\rho_s}{\lambda} \sin \frac{\phi}{2}.$$

This formula is simpler in its application than are those of Debye and Glocker, and it leads to equally reliable information concerning the distances of the electrons from the centers of the atoms. If sufficiently refined measurements of the scattering can be made, however, it may be possible to distinguish between the spatial arrangements considered in the different formulas. If the present conception of an atom in which electrons move in approximately elliptical orbits is correct, none of these expressions is exactly applicable, and only approximate agreement with experiment may be expected.

### 28. *Experiments Showing Interference Effects*

Variations in the intensity of the type predicted by these expressions and illustrated in Fig. 37 have been observed by several experimenters. Friedrich, in connection with his early Laue photographs, noticed that when certain liquids are traversed by X-rays, the diffraction photographs show rings surrounding the central spot,<sup>3</sup> and similar effects have been

<sup>1</sup> A. H. Compton, Washington University Studies, 8, 99 (January, 1921).

<sup>2</sup> A. H. Compton, Washington University Studies, 8, 99 (January, 1921).

<sup>3</sup> W. Friedrich, Phys. Zeits., 14, 317 (1913).

observed by Debye and Scherrer<sup>1</sup> and others. The phenomenon is illustrated nicely by Hewlett's curve of the scattering by mesitylene, shown in Fig. 32 and in Keesom and Smedt's photograph (Fig. 38) of the scattering of the  $K\alpha$  ray of copper by water.<sup>2</sup>

In these figures it will be noticed that just next to the primary beam, where the scattering angle  $\phi$  is small, the intensity of the scattered ray is very low. According to expressions (3.10), (3.12) and (3.13), however, as  $\phi$  approaches zero the intensity approaches a maximum. When this departure from the theory was noticed,<sup>3</sup> it was at once obvious<sup>4</sup> that in

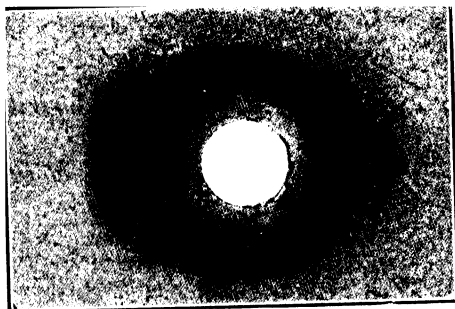

FIG. 38.

liquids such a departure was to be expected because of the destructive interference at small angles between the rays scattered from neighboring molecules. For in a liquid the molecules are not really arranged at random, but possess a certain regularity because they never approach closer than a certain limiting distance from their neighbors. This results at small angles in an interference similar to that obtained with crystals at angles less than that given by  $\lambda = 2D \sin \theta$ . The question of the diffraction of X-rays by liquids has been

<sup>1</sup> P. Debye and P. Scherrer, *Nachr. Göttingen*, 1916; E. Huckel, *Phys. Zeits.* **22**, 561 (1921); R. W. G. Wykoff, *Am. Jour. Sci.* **5**, 455 (1923).

<sup>2</sup> W. H. Keesom and J. deSmedt, *Jour. de Phys.* **4**, 1944 (1923).

<sup>3</sup> C. W. Hewlett, *Phys. Rev.*, **19**, (1922).

<sup>4</sup> A. H. Compton, *Bull. National Res. Council*, No. 20, p. 14 (1922).

examined in outline by Ehrenfest<sup>1</sup> and more thoroughly by Raman and Ramanathan.<sup>2</sup> The rather complicated analysis by the latter authors amounts approximately to identifying the first maximum of the diffraction band with the peak *B* of Fig. 37, the first peak *A* being eliminated by interference.

If this maximum occurs at an angle  $\phi_n$ , it follows that the mean distance between adjacent molecules of the liquid is given, according to equation (3-10), by

$$s = 7.72 \frac{4\pi}{\lambda} \sin \frac{\phi_n}{2}. \quad (3-14)$$

Using this expression, Keesom and Smedt have calculated from their photographs the following intermolecular distances for different liquids:

TABLE III-o

Substance	$\phi$	<i>s</i>	$1.33(M/\rho)^{1/2}$
Oxygen.....	20	4.0A	4.0A
Argon.....	27	4.0	4.1
Benzene.....	18	6.05	5.9
Water.....	29	3.75	3.6
Ethanol...	22	4.9	5.2
Ethyl ether..	19	5.7	6.2
Formic acid. ....	24	4.5	4.5

These values of  $2a$  agree so well with the distance in the last column calculated from the closest packing of spheres that one feels little doubt but that the observed diffraction bands are really due to molecules.

### 29. Empirical Electron Distributions

In other cases, however, in order to account for the observed intensity of the scattered X-rays, it seems necessary to consider

<sup>1</sup> P. Ehrenfest, Versl. Kon. Akad. Wet. Amsterdam, 17, 1184 (1915).

<sup>2</sup> C. V. Raman and K. R. Ramanathan, Proc. Indian Ass. Cultivation Sci. 8, p. 127 (1923).

the distribution of the electrons within the atoms rather than the molecules. Thus the writer has found<sup>1</sup> arrangements of electrons which will give the amount of excess scattering observed by Barkla and Ayers<sup>2</sup> when X-rays traverse carbon, by Owen<sup>3</sup> for filter paper, and by Barkla and Dunlop<sup>4</sup> for aluminum, copper, silver, tin and lead. As an example of this work, we may consider the data of Barkla and Dunlop. Their experimental points, shown in Fig. 39,<sup>4</sup> represent the

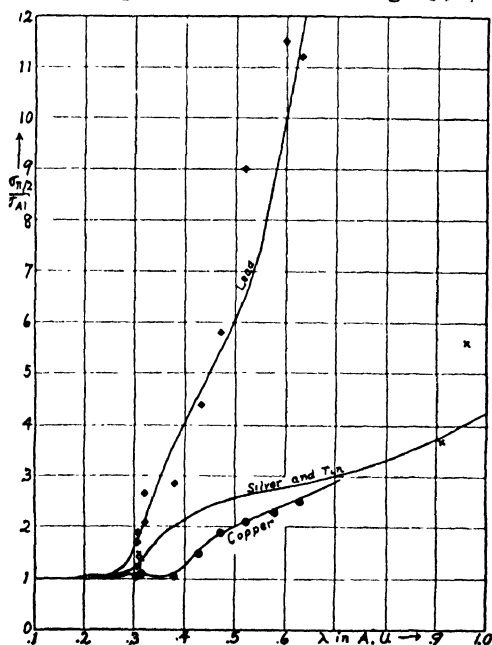

FIG. 39.

relative scattering of X-rays at  $90^\circ$  per gram of various metals as compared with that by aluminium. Supplementary experiments indicated that the scattering by aluminium did not change much with the wave-length, so that in the calculation it was supposed that for this element the electrons scatter inde-

<sup>1</sup> A. H. Compton, Washington U. Studies, 8, 109 (1921)

<sup>2</sup> C. G. Barkla and T. Ayers, Phil. Mag. 21, 275 (1911).

<sup>3</sup> E. A. Owen, Proc. Camb. Phil. Soc. 16, 165 (1911).

<sup>4</sup> C. G. Barkla and J. G. Dunlop, Phil. Mag. 31, 229 (1916).

pends of each other. The curves are calculated from equation (3.13), on the basis of certain arbitrary arrangements of the electrons, and assuming, to take account of the heterogeneity of the X-rays employed, that the frequencies are distributed over a band an octave broad.

The numbers of electrons at different distances from their atomic centers, as employed in these calculations, are as follow:

DISTRIBUTION OF ELECTRONS IN ATOMS, CALCULATED FROM EXCESS SCATTERING  
(Distances in units of  $10^{-8}$  cm.)

Hydrogen	Oxygen		Carbon		Aluminium		Copper		Silver and Tin		Lead	
	No.	Dist.	No.	Dist.	No.	Dist.	No.	Dist.	No.	Dist.	No.	Dist.
1	2	.26	2	.35	2	.12	2	.052	2	.036	2	.022
	6	.42	4	.6	8	.26	10	.104	10	.073	10	.045
					3	.7	8	.4	8	.17	16	.090
							8	.24	16	.34	16	.132
							1	.05	8	.51	16	.202
									4 $\frac{1}{2}$	.7	16	.31
										6	.6	

While the exact distributions thus assigned are of little significance, because of the comparatively low precision of the scattering measurements on which they are based, yet as to order of magnitude the results can hardly be wrong. In any case, these calculations represent one of the most direct experimental determinations of these distances which have so far been made.

### 30. Scattering by Any Grouping of Electrons

It is possible to solve formally the problem of the scattering by electrons arranged in any grouping whatever.<sup>1</sup> Although this solution will not be in a form which we can use to predict the intensity of the radiation scattered by the group, we shall nevertheless be able to arrive at some interesting deductions from the solution. We start with Debye's expression (3.12)

<sup>1</sup> Cf. A. H. Compton, *Phil. Mag.* 41, 770, 1921.

for the scattering by a group of  $Z$  electrons. This expression is not perfectly general, since it supposes that the distances  $s_{mn}$  between the different electrons remain fixed. In an atom consisting of electrons revolving in different orbits about the nucleus, this condition obviously is not satisfied. In order to take account of these motions, we may suppose that the probability that the distance  $s_{mn}$  will lie between  $s_{mn}$  and  $s_{mn} + ds_{mn}$  is  $p_{mn} ds$ . The average value of the intensity for all possible distances  $s_{mn}$  is then,

$$I_{\phi} = I_c \sum_1^Z \sum_1^Z \int_0^{\infty} \frac{\sin \left[ \frac{\sin \phi/2}{\lambda} \cdot 4\pi s_{mn} \right]}{\frac{\sin \phi/2}{\lambda} \cdot 4\pi s_{mn}} p_{mn} ds_{mn}. \quad (3.15)$$

This expression is perfectly general, as long as the forces of constraint upon the electrons are negligible.

The interesting point regarding this expression is that  $\phi$  and  $\lambda$  enter only in the form  $\frac{\sin \phi/2}{\lambda}$ . We may accordingly write

$$I_{\phi}/I_c = F\left(\sin \frac{\phi}{2}/\lambda.\right) \quad (3.16)$$

### 31. *A Method of Comparing Wave-lengths*

Two applications of this result may be made. In the first place it will be seen that it affords us a means of comparing different wave-lengths. For if the value  $(I_{\phi}/I_c)_1$  is determined for some particular angle and wave-length  $\phi_1$  and  $\lambda_1$ , and if for some unknown wave-length  $\lambda$  the angle of scattering  $\phi$  is determined for which  $(I_{\phi}/I_c) = (I_{\phi}/I_c)_1$ , then according to equation (3-16),

$$F\left(\sin \frac{\phi}{2}/\lambda\right) = F\left(\sin \frac{\phi_1}{2}/\lambda_1\right),$$

whence <sup>1</sup>

$$\sin \frac{\phi}{2}/\lambda = \sin \frac{\phi_1}{2}/\lambda_1,$$

<sup>1</sup> If  $F(x)$  is a multiple valued function, it is of course possible that  $F(x)$  might equal  $F(x')$  when  $x$  is not equal to  $x'$ . In the physical problem, however, uncertainties from this source can be avoided.

or

$$\lambda = \frac{\sin \phi/2}{\sin \phi_1/2} \lambda_1. \quad (3.17)$$

Thus by measuring angles  $\phi$  and  $\phi_1$  and the wave-length  $\lambda_1$ , the unknown wave-length may be determined.

This result has been applied in the determination of the effective wave-length of the hard  $\gamma$ -rays from radium C.<sup>1</sup> A measurement of the scattering of these rays by lead and copper showed that at  $\phi = 10$  degrees the ratio of the intensity from lead to that from copper was about 11 per cent greater than it was at large angles. Barkla and Dunlop, in the experiments shown in Fig. 39, measured the ratio of these intensities for certain known wave-lengths scattered at 90 degrees. At  $0.3A$  their value of the ratio  $I_{\text{lead}}/I_{\text{copper}}$  per electron is about 1.75, and it is clear that we should have to go to a yet shorter wave-length to obtain the rate 1.11 observed in the  $\gamma$ -ray experiments. We can thus say, from equation (3-26), that

$$\begin{aligned} \lambda_{\gamma\text{-rays}} &< \frac{\sin (\frac{1}{2} 10^\circ)}{\sin (\frac{1}{2} 90^\circ)} 0.3A \\ &< .037A. \end{aligned}$$

From an extrapolation of Barkla and Dunlop's data, the effective wave-length of the hard  $\gamma$ -rays from radium C was estimated by this method as about  $.025A$ .<sup>2</sup>

At the time that this result was published, the only other method of measuring the wave-length of these  $\gamma$ -rays, that of crystal reflection,<sup>3</sup> had given a value of  $\lambda = 0.07A$  for the shortest wave-lengths emitted by radium C; but absorption measurements showed that these rays could not be identical with the penetrating  $\gamma$ -rays used in the scattering experiments. By a

<sup>1</sup> A. H. Compton, *Phil. Mag.* 41, 770 (1921).

<sup>2</sup> In the author's original paper (*loc. cit.*) the value from 0.025 to 0.030 was given as the effective wave-length from these experiments. More mature consideration of the experiments led the writer to choose the lower limit thus assigned, 0.025 A, as the more probable value of the effective wave-length (*Bulletin National Research Council No. 20*, p. 31, (1922).

<sup>3</sup> E. Rutherford and E. N. C. Andrade, *Phil. Mag.* 28, 263 (1914).

variety of different methods, the effective wave-length of these rays is now estimated as about  $.017\text{\AA}$  (Appendix II). This method of estimating the wave-length from the amount of excess scattering is thus seen to lead to results as accurate as could be expected from the data used.

### 32. *A Failure of the Wave Theory of Interference*

The second application of the result expressed by equation (3.16) is a test of the electromagnetic wave theory of interference. Let us choose two wave-lengths  $\lambda$  and  $\lambda'$  and two angles  $\phi$  and  $\phi'$  such that

$$\sin \frac{\phi}{2} / \lambda = \sin \frac{\phi'}{2} / \lambda'.$$

Then by equation (3.25),

$$I_{\phi} / I_e = I_{\phi'} / I_e'. \quad (3.18)$$

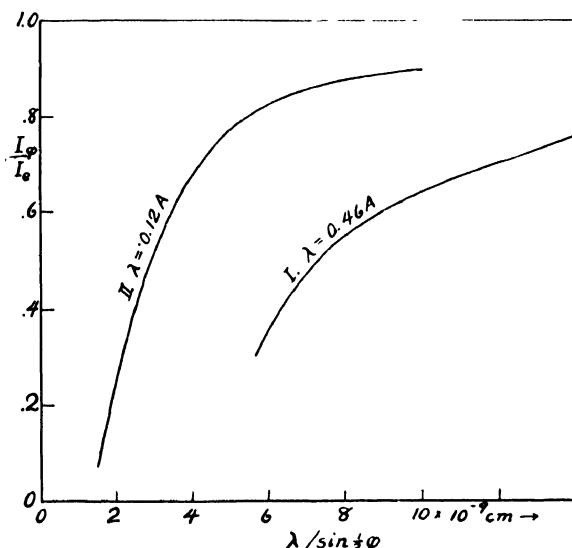

FIG. 40.

A test of this expression,<sup>1</sup> for the wave-lengths  $0.46\text{\AA}$  and  $0.12\text{\AA}$  scattered at different angles by paraffin, is shown in Fig. 40. In this figure, the ratio  $I_{\phi} / I_e$  is plotted against  $\lambda / \sin \frac{1}{2} \phi$ ,

<sup>1</sup> A. H. Compton, Bull. Nat. Res. Council, No. 20, p. 10 (1922).

and should by (3.18) be the same for all wave-lengths, that is, the lines *I* and *II* should be coincident. For  $I_\phi$  only that part of the secondary X-rays which is of the same wave-length as the primary is used, since this is the only part which, according to the classical theory, can be truly scattered. The wide difference between curves *I* and *II* shows the failure of equation (3.18). Unless we postulate the existence of strong damping or constraining forces effective at high frequencies which are negligible for ordinary X-rays, such a result is inconsistent with the classical electron theory.<sup>1</sup>

Of course this failure of equation (3.18) throws doubt on the validity of equation (3.17) and its use for determining wave-lengths. In view of the fact, however, that equation

(3.17) is applied to cases where  $\sin \frac{\phi}{2} / \lambda$  is comparatively

small, it is possible that this difficulty may not be as serious as would at first sight appear.

### 33. *Attempts to Account for the Small Scattering of Hard X-rays*

Several attempts, on the basis of the classical electrodynamics, have been made to account for the fact that for X-rays of very short wave-length the intensity of the scattered X-rays is considerably less than is predicted by equations (3.05) and (3.06). We see from Fig. 37 that though at certain angles the intensity of the ray scattered by a pair of electrons may be less than the sum of the rays scattered by two independent electrons, on the average the effect of interference is to increase the intensity of the scattered rays. Similarly the more general equation (3.13) leads to a scattering coefficient greater than that given by equation (3.06), and hence greater than the experimental values for hard X-rays. It is therefore impossible to account for this reduced scattering from considerations of interference.

<sup>1</sup> This is perhaps the most definite departure from the laws of diffraction which has so far appeared.

34. *Constraining and Damping of Electrons' Motions*

Perhaps the most valiant attempt to reconcile these experiments with the classical electron theory has been made by Schott.<sup>1</sup> He has investigated the effect on the scattering of X-rays of various types of constraining and damping forces on the electrons. If one supposes that the constraining force is proportional to the displacement, and that the damping force is proportional to the velocity, the equation of motion of the forced oscillation of the electron due to the primary wave is:

$$m \frac{d^2x}{dt^2} + rm \frac{dx}{dt} + q^2 mx = Ae \cos pt, \quad (3.19)$$

where  $A \cos pt \equiv E_x$  is the electric field due to the incident wave. The solution of this equation after the system has reached a steady state of oscillation, is

$$x = -A_1 \cos(pt + \delta), \quad (3.20)$$

where

$$A_1 = \frac{Ae}{mp^2} / \left\{ \left( 1 - \frac{q^2}{p^2} \right)^2 + \frac{r^2}{p^2} \right\}^{1/2},$$

and

$$\delta = \tan^{-1} \left\{ \frac{r}{p} / \left( 1 - \frac{q^2}{p^2} \right) \right\}.$$

The acceleration of the electron is thus

$$\begin{aligned} a &= \frac{d^2x}{dt^2} = p^2 A_1 \cos(pt + \delta) \\ &= \frac{Ae \cos(pt + \delta)}{m} / \left\{ \left( 1 - \frac{q^2}{p^2} \right)^2 + \frac{r^2}{p^2} \right\}^{1/2}. \end{aligned}$$

But if the electron were free its acceleration would have been

$$a_f = \frac{Ae}{m} \cos(pt + \delta).$$

<sup>1</sup> G. A. Schott, Proc. Roy. Soc. A. 96, 395 (1920).

In view of the fact that the electric vector of the scattered wave is proportional to the acceleration of the scattering electron, and since the intensity of the ray is proportional to the square of the amplitude of the electric vector, we can say at once that the ratio of the intensity of the ray scattered by the electron under consideration to that scattered by a free electron is

$$\frac{I'_r}{I_e} = \frac{a_{\max}^2}{a_{f\max}^2} = 1 / \left\{ \left( 1 - \frac{q^2}{p^2} \right)^2 + \frac{r^2}{p^2} \right\}. \quad (3.21)$$

An examination of this equation shows that if the frequency of the X-ray is greater than the natural frequency of the electron ( $p > q$ ) the intensity of the scattered ray will always be greater for a bound electron than for a free electron. The intensity of the scattered ray becomes smaller than that for a free electron only if  $2p^2 < q^2$ , that is for frequencies considerably smaller than the natural frequency of the electron. Thus the effect on the scattered X-rays of constraining forces on the scattering electrons should be greatest at comparatively low frequencies, and should become negligible at very high frequencies. Experiment, on the other hand, shows that at moderate frequencies the scattering by light elements is about that anticipated from free electrons, while the great departure is at the highest frequencies. Constraining forces on the electrons are thus inadequate to account for the reduced scattering at high frequencies.

An increase in the damping constant  $r$  would, as is evident from equation (3.21), reduce the intensity of the scattered ray. But in order that this effect should not approach zero at high frequencies  $r$  must increase rapidly as  $p$  increases.

Let us suppose that this damping is due to the energy radiated by the scattering electron. We have noticed that the mean rate of energy loss from an oscillating electron due to its own radiation is (equation 2.17)

$$\overline{\frac{dW}{dt}} = \frac{1}{3} \frac{e^2}{c^3} A_1^2 p^4,$$

where  $A_1$  is the amplitude of the electron's displacement. But from equations (3.19) the rate of energy loss at any instant due to damping is

$$\frac{dW_r}{dt} = rm \frac{dx}{dt} \cdot \frac{dx}{dt} = rm \left( \frac{dx}{dt} \right)^2,$$

which, according to (3.20) is

$$\frac{dW_r}{dt} = rm \cdot p^2 \cdot A_1^2 \sin^2 (pt + \delta).$$

When averaged over a complete cycle, this becomes

$$\overline{\frac{dW_r}{dt}} = \frac{1}{2} rmp^2 \cdot A_1^2. \quad (3.22)$$

If then we suppose that the damping is due to the radiation, we have at once that

$$\frac{1}{2} rmp^2 \cdot A_1^2 = \frac{1}{3} \frac{e^2}{c^3} \cdot A_1^2 p^4,$$

or

$$r = \frac{2}{3} \frac{e^2 p^2}{mc^3}. \quad (3.23)$$

Thus

$$\frac{r^2}{p^2} = \frac{4}{9} \frac{e^4 p^2}{m^2 c^6}. \quad (3.24)$$

For the highest frequencies at which scattering experiments have been made, i.e., for  $\gamma$ -rays of wave-length  $0.02\text{\AA}$ , the value of this ratio is  $0.000035$ . It follows from equation (3.21) that the effect of this damping on the intensity of the scattered X-rays is wholly negligible.

We have seen that for hard X-rays traversing light elements the absorption coefficient falls below the value calculated from the classical theory for the absorption due to scattering alone. When we examine the absorption of X-rays on the classical theory we shall see (equation (6.24)) that the absorption coefficient is proportional to the damping constant  $r$ , the factor of proportionality being such that if we use the value of  $r$  given by

(3.23) the absorption coefficient is just equal to the scattering coefficient. Thus the observation that the absorption coefficient is less than the theoretical scattering coefficient would mean that the damping constant must be even less than the value given by (3.23), so that the effect of the damping in equation (3.21) will be wholly negligible. Thus we are forced to the conclusion at which Schott arrived, that neither by forces of constraint nor by damping forces can we account for the fact that at very high frequencies the scattering by an electron is less than that calculated for a free electron.

### 35. *The Complex Electron*

It would seem that the only escape from our difficulty, consistent with classical electrodynamics, is to suppose either that the force on an electron at rest is for high frequencies less than the value  $Ee$ , as assigned by Lorentz's force equation, or that the electric field due to an accelerated electron is less than is calculated from the usual electron theory. The possibilities in this direction resulting from assuming a new force equation have been investigated by Maizlish.<sup>1</sup> Taking the special case of an electron composed of two parts having equal charges but different masses, which are held together by certain pseudo-elastic and frictional forces, he finds an intensity of scattering which for high frequencies falls below that calculated from the usual theory.

One might criticize the particular model employed by Maizlish in that energy seems to be absorbed (and retained indefinitely) by the electron, but probably some other method of altering the force equation might be postulated which would be free from this objection. We should thus be afforded, however, with a solution of only half of our problem. We have seen that as the frequency of the X-rays increases, the rays scattered at large angles decrease in intensity more rapidly than those at small angles, with the result that an asymmetry appears, similar to that due to interference when soft X-rays are used. This

<sup>1</sup> I. Maizlish, *Jour. Franklin Inst.*, May, 1924.

asymmetry is shown clearly in Fig. .33, which represents the scattering of hard  $\gamma$ -rays by iron. It is clear that a mere modification of the force equation will only modify the absolute intensity of the scattered beam, but can have no effect on its angular distribution.

### 36. *The Large Electron*

A suggestion that at one time seemed to be very promising was that the electron, instead of being sensibly a point charge, has instead dimensions comparable with the wave-length of hard gamma rays.<sup>1</sup> The effect of this hypothesis is to make possible interference between the rays scattered from different parts of the electron. For wave-lengths considerably greater than the diameter of the electron, this interference would be negligible, and the electrons would act as described by the usual electron theory. If the wave-length is shorter, since the phase differences from different parts of the electron are larger for rays scattered backward than for those scattered at small angles, the intensity in the reverse direction should fall off the more rapidly. Qualitatively, therefore, this hypothesis is adequate to account for both the reduced intensity and the asymmetry of the scattered X-rays of very short wave-length.

In order to avoid conflict with a view that an electron's mass is due to its electromagnetic inertia, we may suppose that the electron has the form of a thin circular ring of electricity. For such an electron, with certain reasonable auxiliary assumptions, it can be shown<sup>2</sup> that the intensity of the ray scattered by a single ring electron of radius  $a$  should be

$$I_r = I_e \frac{1}{x} \sum_0^{\infty} J_{2n+1}(2x), \quad (3.25)$$

where  $I_e$  is given by equation (3.08),  $x = \frac{4\pi a}{\lambda} \sin \frac{\phi}{2}$ , and  $J_n$  is Bessel's  $J$  function of the  $n$ th order. This expression for the

<sup>1</sup> A. H. Compton, Jour. Washington Acad. Sci., 8, 1 (1918); Phys. Rev. 14, 20 (1919).

<sup>2</sup> A. H. Compton, Phys. Rev. 14, 20 (1919); Washington U. Studies, 8, 104 (1921); G. A. Schott, Proc. Roy. Soc. 96, 695 (1920).

intensity of the rays scattered at different angles from a ring electron is found to be in surprisingly good accord with the experimental values, if the radius of the ring is assumed to be about  $3 \times 10^{-10}$  cm.<sup>1</sup>

This theory fails, however, as any theory based upon the classical electrodynamics must fail, to account for the change in the wave-length of the scattered X-rays. In view of the fact that the quantum theory which leads to a correct expression for the change of wave-length suggests also an adequate explanation of the reduced intensity of scattered X-rays of very high frequency, such arbitrary assumptions regarding the nature of the electron are unnecessary. It seems futile, therefore, to carry the discussion of the scattering of hard X-rays further from the standpoint of the classical electrodynamics.

### 37. *Summary*

The classical electromagnetic theory of scattering in its simplest form is quantitatively applicable to the scattering of comparatively soft X-rays by elements of low atomic weight. But when heavier elements are employed as radiators, the interference between the rays scattered by the different electrons becomes appreciable, giving rise to what is known as "excess scattering." We find that it is possible to choose electron distributions within the atom which will give closely the observed intensity of scattering of ordinary X-rays, thus affording a means of studying these electronic arrangements. For very short waves, however, we find that the intensity of the scattered X-rays is less than can be accounted for on the theory of electromagnetic waves, the difference being greater when the scattered ray makes a large angle with the primary ray. This fact, coupled with the observation that the wave-length of the scattered rays is always greater than that of the primary beam, indicates that there is some fundamental fault in the classical explanation of X-ray scattering.

<sup>1</sup> Cf. *e.g.*, A. H. Compton, Bulletin Nat. Research Coun. No. 25, p. 10 (1922).

## CHAPTER IV

### X-RAY REFLECTION AND CRYSTAL STRUCTURE <sup>1</sup>

#### 38. *Laue's Discovery and its Consequences*

“ If,” as Henri Poincare has said, “ the value of a discovery is to be measured by the fruitfulness of its consequences, the work of Laue and his collaborators should be considered as perhaps the most important of modern physics.” <sup>1</sup> In the diffraction of X-rays by crystals we have a tool which has enabled us to show at once the identity in character of X-rays and light, and to determine with a definiteness previously almost unthinkable the manner in which crystals are constructed of their elementary components. By its help we have studied the spectra of X-rays, we have learned to count one by one the electrons in the different atoms, and we have found out something with regard to arrangement and the motion of these electrons. The measurement of X-ray wave-lengths which is thus made possible has supplied us with our most precise method of determining Planck's radiation constant  $h$ , and in showing the change of wave-length when these rays are scattered has demonstrated the existence of quanta of momentum of radiation which had hitherto been only vaguely suspected. Thus in the two great fields of modern physical inquiry, the nature of matter and the nature of radiation, Laue's discovery of the diffraction of X-rays by crystals has opened the gateway to many new and fruitful paths of investigation.

It is not the purpose of the present chapter to present in detail an analysis of all the crystals whose structure has been

<sup>1</sup> I am indebted to Mr. J. K. Morse for many helpful suggestions in writing this chapter.

<sup>2</sup> M. de Broglie, “Les Rayons X” (1922).

determined by X-ray methods. We shall rather confine ourselves to a description of the most important methods by which such investigations are carried out, and to the study of the structure of some of the simpler crystals as examples of the various methods. Before entering this discussion it will be advisable to review some of the nomenclature used in crystallography. For a more detailed discussion of the analysis of crystal structure, the reader may be referred to that remarkable book, "X-rays and Crystal Structure," by W. H. Bragg and W. L. Bragg, on which much of the following chapter is based.

### 39. *The Space Lattice*

The feature which distinguishes a crystalline from an amorphous substance is the fact that the fundamental units of the crystalline substance are arranged in a systematic pattern. Before X-ray methods were employed, measurements with a goniometer of the angles between the external faces had led to the classification of all kinds of crystals into six systems of symmetry, and these systems were further divided into thirty-two classes under which any particular crystal could be assigned.<sup>1</sup> The geometrical theory of crystal structure worked out by Bravais, Schoenke, Schoenflies, von Federoff and Barlow showed that these thirty-two classes could be still further extended into two hundred and thirty space groups, which represent all the possible ways of systematically arranging the fundamental crystallographic units in space.

Before the application of X-rays to the study of crystals, it was not possible, in the case on any particular crystal, to determine the nature of the fundamental units underlying its structure, the distances separating these units, or the space group to which it belonged. By X-ray analysis we can learn whether the crystallographic units are atoms, ions, molecules or groups of molecules. We can determine, with a few minor exceptions, the space group to which a particular crystal belongs. And

<sup>1</sup> An excellent account of the modern methods of crystal measurement is to be found in *Crystallography and Practical Crystal Measurement*, A. E. H. Tutton, Macmillan,

what is yet more remarkable, we can measure with precision the actual distances between the atoms, ions or molecules.<sup>1</sup>

The units of which a crystal is composed may be either simple or complex, a single atom, or ion or a complicated molecule or even a group of complicated molecules. There must, however, exist some unit which occurs in the crystal in a regular repeating order, such that the situation of one of these units with regard to its neighbors is precisely similar to that of any other unit. We may take some point in this unit, for example the center of some atom, to represent the position of the unit. The group of such points is known as the space lattice of the crystal. It is found that any such space lattice of points may be connected by a three-dimensional network of lines which form the edges of a group of parallelopipeds. Fig. 41 shows the space lattices to which all crystals may be referred.<sup>2</sup>

#### 40. *Cubic Lattices*

If, for example, we desire to examine a cubic crystal, we know at the start that it must be built up from a simple cubic, a body centered cubic, or a face centered cubic lattice. The first question is to determine by means of X-rays which one. To do this we must be able to specify and identify in the actual crystal

<sup>1</sup> Inasmuch as this new analysis forms an extension of our previous knowledge of crystals and requires use of the results of the older goniometric measurements, the compilation by P. Groth of the external measurements of crystals in "Chemische Crystallographie," Leipzig, 1906, five volumes, forms an invaluable starting point for crystal analysis.

<sup>2</sup> Space does not permit the explanation of the detailed relations between these lattices and the 32 crystal classes and the space groups mentioned above. It will be noted, however, that all crystals can be divided into two main divisions which differ radically in their structure, namely, atomic or ionic lattices such as diamond and the alkali halides, and molecular lattices to which the majority of the organic compounds belong.

All the possible space groups have been worked out analytically for ionic and atomic lattices by Wyckoff in his monograph, "The Analytical Expression of the Results of the Theory of Space Groups," Washington, 1922. For molecular lattices, on the other hand, W. T. Astbury and Kathleen Yardley, "Tabulated Data for the Examination of the 230 Space Groups by Homogenous X-rays," Phil. Trans. 224A, 221-259, 1924, have presented a more satisfactory discussion.

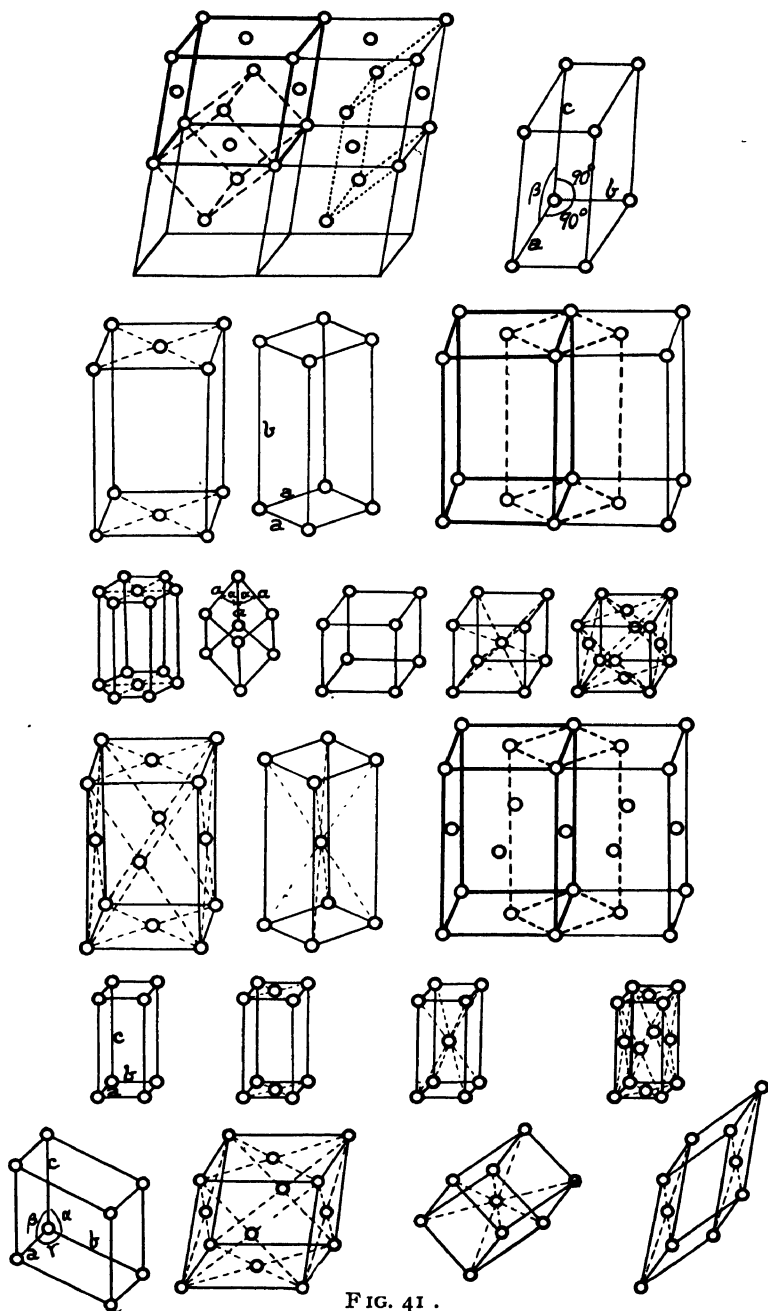

FIG. 41 .

certain planes which include certain points in the space lattice. This may be done in the following manner.

Let  $a, b, c$ , of Fig. 42 represent the edges of the unit parallelepiped along its three axes, and let  $A, B, C$ , be the plane to be described. This plane intersects the axes at distances  $OA = pa$ ,  $OB = qb$  and  $OC = rc$  respectively, where  $p, q$  and  $r$  are integers. The reciprocals of these numbers are in the ratio

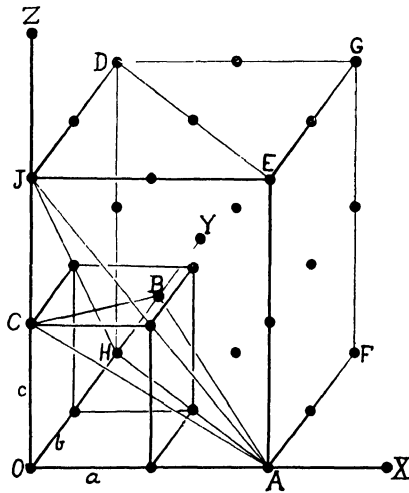

FIG. 42.

$qr : rp : pq$ , respectively. If these products are each divided by their greatest common divisor  $n$ , we obtain the integers

$$h = qr/n, \quad k = rp/n, \quad l = pq/n. \quad (4.01)$$

These are known as the (Miller) *indices* of the plane in question, and are written in brackets, thus  $(h, k, l)$ . The plane  $ABC$  is thus known as the  $(h, k, l)$  plane, and the ratios  $a : b : c$  are known as the *axial ratios*.

For the plane  $ABC$ ,  $p = 2, q = 3, r = 1$ , and  $n = 1$ , whence  $h = 3, k = 2$  and  $l = 6$ . The plane  $ABC$  is thus the  $(3, 2, 6)$  plane of the lattice. Similarly for the plane  $AFGE$ ,  $p = 2, q = \infty, r = \infty$ , whence  $h = 1, k = 0$  and  $l = 0$ , so this is the  $(1, 0, 0)$  plane. In the same manner the points  $AHDE$

are in the  $(1, 1, 0)$  plane and the points  $AHJ$  are in the  $(1, 1, 1)$  plane.

In the three fundamental cubic lattices, as shown in Fig. 43, if we call the distance between the layers of points in the  $(100)$

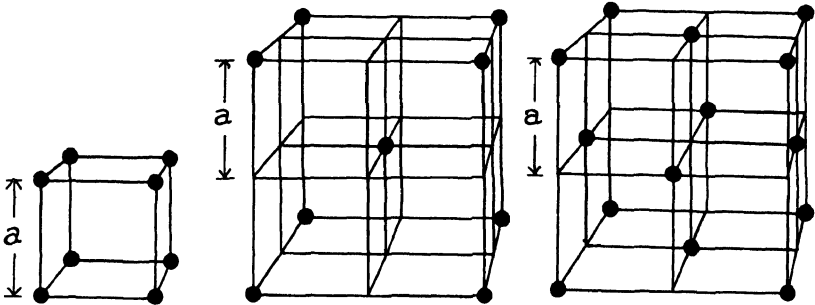

FIG. 43.

planes  $a$ , the distances between the successive layers of points in the other planes are those given in the following table:

TABLE IV-1  
DISTANCE BETWEEN PLANES OF A CUBIC CRYSTAL.

Type of Crystal	$(100)$ Planes	$(110)$ Planes	$(111)$ Planes
Simple cubic.....	$a$	$1/\sqrt{2} \cdot a$	$1/\sqrt{3} \cdot a$
Body centered.....	$a$	$2/\sqrt{2} \cdot a$	$1/\sqrt{3} \cdot a$
Face centered.....	$a$	$1/\sqrt{2} \cdot a$	$2/\sqrt{3} \cdot a$

It is clear that if we can by any means measure the relative distance between these different planes we shall have a key to the distribution of the points on the space lattice.

#### 41. Crystal Structure by X-ray Reflection from Crystal Faces

The most straightforward method of determining the arrangement of the atoms in crystals is that which was first employed by W. L. Bragg in studying the structure of rock-salt ( $\text{NaCl}$ ) and sylvine ( $\text{KCl}$ ). These are both cubic crystals which, in

view of their similar chemical constitution and crystal form, are presumably alike in structure. The information regarding their structure is obtained by reflecting a beam of X-rays from certain characteristic planes, and by measuring the intensity of this reflection at different angles. The spectra shown in Fig. 44 give the result of such an experiment, when X-rays from a tube with a palladium target are reflected by these crystals.

In Chapter I we showed that if X-rays of wave-length  $\lambda$  are reflected from a crystal composed of layers of particles spaced a

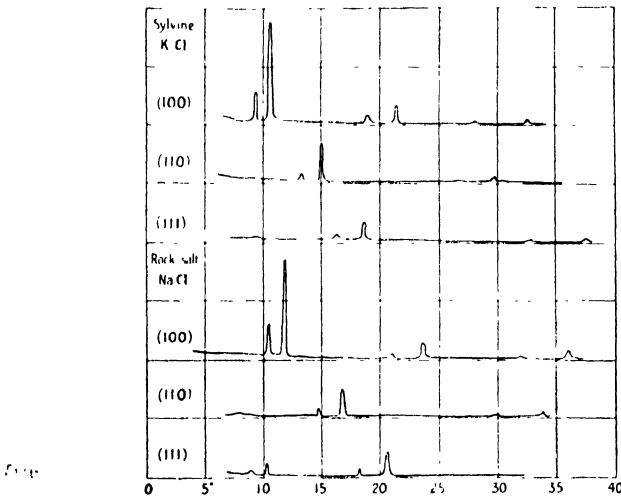

FIG. 44.

distance  $D$  apart, the reflection will occur when the glancing angle is given by the relation

$$n\lambda = 2D \sin \theta, \quad (1.03)$$

where  $n$  is the order of reflection.

The distance between the successive layers is thus,

$$D = n\lambda/2 \sin \theta. \quad (4.02)$$

Thus in the case of sylvine, experiment shows the grating spaces for the (100), (110) and (111) planes to be in the ratio  $1/\sin 5.22^\circ : 1/\sin 7.30^\circ : 1/\sin 9.05^\circ$ , which is very nearly the

ratio  $1 : 1/\sqrt{2} : 1/\sqrt{3}$ . A comparison of these results with the calculated ratios of Table IV-1 shows that we are dealing here with particles arranged according to a simple cubic lattice. We have as yet, however, no information as to whether the particles so arranged are atoms, molecules or groups of atoms.

In the case of rock-salt, however, Fig. 44 shows a weak first order reflection from the (111) plane at half the angle at which the reflection should occur if this crystal acted precisely as does sylvine. If we were to ignore this feeble reflection, we should have, considering the strong reflections only, the same ratios for the grating spaces for the different planes as was found for sylvine. But taking this weak first order reflection into account, the ratio of these distances is

$$D_{100} : D_{110} : D_{111} = 1 : 1/\sqrt{2} : 2/\sqrt{3}.$$

According to Table IV-1, these are the distances characteristic of a face-centered cubic lattice. This crystal therefore acts very much as if it were a simple cubic lattice superposed upon a face-centered cubic lattice.

The following solution of this problem was suggested by Bragg: Let us imagine both NaCl and KCl to be represented by Fig. 45, where the solid circles represent atoms of chlorine and the open circles atoms of sodium or potassium as the case may be. There is thus an atom at each corner of each of the small cubes into which the figure is divided.

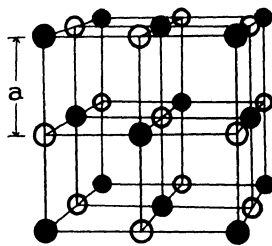

FIG. 45.

In view of the considerations brought forward in the last chapter, we may suppose that it is the electrons within the atoms which are responsible for the scattering of the X-rays. Taking the number of electrons as equal to the atomic number, we should then have 11 electrons in the sodium atom, 17 in chlorine and 19 in potassium. But since NaCl and KCl are polar compounds, we may suppose that the valence electron has left the

sodium or potassium atom and has joined the chlorine atom. Thus we should have in the crystal 10 electrons in sodium, and 18 in both chlorine and potassium. It is thus natural to suppose that chlorine and potassium atoms scatter about the same amount, but that the sodium atom scatters less than the other two. Thus a KCl crystal represented by Fig. 45 should scatter as would a simple cubic lattice of similar particles. In NaCl, on the other hand, we can think of the arrangement as consisting of 10 electrons at each point of a cubic lattice of edge  $a$ , and superposed on this 8 electrons at each point of a face-centered lattice of cube edge  $2a$ . This would give 18 electrons at each of the chlorine atoms and 10 at each of the sodium atoms, and would also give rise to exactly the type of superposed spectrum which is found from the (111) planes of rock-salt.

It will be worth while to consider the matter from a slightly different standpoint. Referring again to Fig. 45, it will be seen that the successive layers of atoms in the (100) and (110) planes are identical with each other, each layer containing equal numbers of sodium and chlorine atoms. In the (111) planes, however, layers of sodium and chlorine atoms alternate with each other. If we were to consider the heavier chlorine atoms by themselves, they would give rise to a reflection as from a grating space of  $2/\sqrt{3}a$ . But if there is 1 wave-length difference in path between the rays scattered by the successive layers of chlorine atoms, there will be just half a wave-length difference between the rays scattered by a layer of chlorine atoms and the adjacent layer of sodium atoms. These two rays will therefore be opposite in phase, but will not completely interfere, since the ray scattered by the chlorine atoms is the stronger. There is thus produced a weak first order line from the (111) planes, which is observed at about 5.1 degrees. In the second order reflection from the chlorine layers, the difference in path between rays from successive layers of chlorine atoms will be two wave-lengths and that between adjacent layers of sodium and chlorine atoms one complete wave-length. In this case all the atoms will cooperate in their scattering, and the intensity will be much greater than in the first order. Thus we may expect from the

(III) planes of rock-salt that the odd orders will be relatively weak and the even orders of reflection relatively strong.

The complete accord between the predictions based on this grouping of the atoms and the experimental spectra from rock-salt and sylvine, together with the simplicity of the arrangement, makes this structure appear very plausible. It cannot be said that the proposed arrangement is the only one which will work. We might, for example, place 2 atoms instead of 1 at each point of the space lattice. Chemically, however, such a distribution would present grave difficulties, whereas the one pictured in Fig. 45 is quite acceptable.

#### 42. *Confirmation by Measurement of X-ray Wave-lengths*

Perhaps the best verification of this structure is the fact that the wave-length of the X-rays calculated on the basis of the arrangement of the atoms, shown in Fig. 45 is in agreement with that determined by other methods. Assuming this structure, we showed in Chapter I that the grating space for the (100) planes of rock-salt is  $D = (W/2N\rho)^{1/3}$ ,  $= 2.81 \times 10^{-8}$  cm., where  $W$  is the molecular weight,  $\rho$  the density of sodium chloride, and  $N$  is the number of molecules per gram molecule. Using this grating space, the wave-length of the palladium X-rays used may be calculated from the formula  $n = 2D \sin \theta$  to be 0.576A. There are, however, several other methods by which the wave-length of X-rays can be determined. The most direct of these is that based upon the diffraction of X-rays by ruled gratings. This work, as we have seen (*supra*, p. 17), gives a wave-length identical within an experimental error of about 0.3 per cent, with that determined by crystal methods. It follows that the grating space which we have assigned to rock-salt and sylvine is correct. But if this grating space is right, there can be only one atom placed in each unit cube of side  $a$ , and it would seem that the distribution of the atoms shown in Fig. 45 is the only one possible.

## 43. Reflection Method Using Known Wave-length

Having thus determined the wave-length of the X-rays which we are using, the analysis of the structure of other crystals is considerably simplified. Let us consider, for example, the case of diamond. This crystal is also of the cubic system. The spectra from the three characteristic faces are shown diagrammatically in Fig. 46. The palladium  $K\alpha$  line ( $\lambda = 0.576$ ) is reflected from the (100) face at  $19.0^\circ$  in the first order, indicating a grating space of  $0.885 \times 10^{-8}$  cm. The volume of a cube of this edge is  $0.691 \times 10^{-24}$  cm.<sup>3</sup>. But since the number of atoms

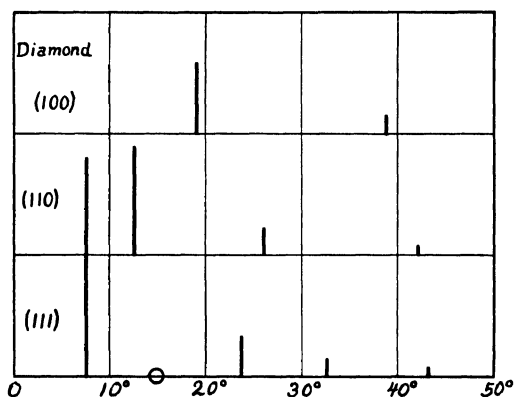

FIG. 46.

of carbon per unit volume is  $N\rho/W$ ,  $N$  being the number per gram atom,  $W$  the atomic weight and  $\rho$  the density of diamond, the volume associated with each atom is  $W/N\rho = 12/6.06 \times 10^{23} \times 3.51 = 5.6 \times 10^{-24}$  cm.<sup>3</sup> This is  $5.6/0.69 = 8.1$  times the volume of our unit cube. In order to have 1 atom associated with each unit cube, we must therefore have the side of our unit cube equal to  $2 D_{100}$ .

The spacings for the three characteristic planes will be seen from Fig. 46 to be in the ratios

$$D_{100} : D_{110} : D_{111} = \frac{1}{2} : 1/\sqrt{2} : 2/\sqrt{3}.$$

Of the ratios corresponding to the three simple cubic arrangements given in Table III, these agree most closely with those

for the face-centered cube. We may therefore take this lattice as our starting point to build up the crystal structure (Fig. 47, the solid circles). Let us consider, in Fig. 47, that the cube associated with any particular atom is the one which has the atom at its lower, front, left-hand corner. It will then be seen that only half of the cubes are associated with the atoms represented by the solid circles. In order to have one atom associated with each unit cube we must therefore locate an equal number of additional atoms. Since the grating space  $D_{100}$  is  $\frac{1}{2}$  that of the "black" atoms, the additional "white" atoms must all be placed midway between the (100) planes of the black atoms.

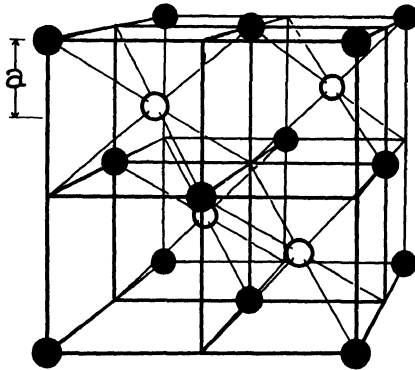

FIG. 47.

This can only be done by placing the white atoms at the centers of the cubes drawn in Fig. 47. But only half of the cubes require atoms in order to make up the full number of 1 atom per cube. If therefore we place the white atoms in the centers of the cubes with which black atoms are not already associated, we obtain the required distribution.

The spacings of the atomic layers in the different planes according to this structure are shown diagrammatically in Fig. 48. In the (100) and the (110) planes the successive layers are equal and are equally spaced. In the (111) plane, however, we have equal layers of atoms arranged in pairs, such that the distance between the two layers of a pair is  $\frac{1}{4}$  the distance between two successive pairs. We should therefore expect the

intensities of the higher orders from the (100) and the (110) planes to fall off in the normal manner. But at the angle for the second order reflection from the (111) plane the ray scattered from the two layers of the same pair will be opposite in phase and should just neutralize each other. We should therefore expect the second order reflection to be absent from the reflection by the (111) faces of diamond. A glance at the spectra shown in Fig. 46 shows that this is indeed the case. The information given by the absence of this second order reflection

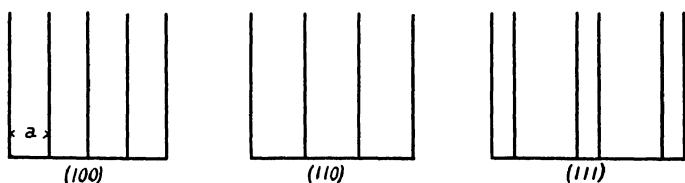

FIG. 48.

has not been used in determining the crystal structure shown in Fig. 47. The fact that this structure predicts its absence is therefore an independent verification of the structure that has been assigned.

#### 44. Powdered Crystal Method of X-ray Crystal Analysis

In order to employ the method of reflection which has just been described it is necessary to use crystals with faces large enough to be set with the desired orientation on the crystal table of the spectrometer. Many substances, including most of the chemical elements, are not available in the form of such crystals. These materials can have their structure examined by the powdered crystal method, developed by Debye and Sherrer<sup>1</sup> and Hull.<sup>2</sup>

Instead of observing the reflections from different crystal faces one at a time, one may use a very large number of finely pulverized crystals, among which some will always be oriented

<sup>1</sup> Debye and Sherrer, *Phys. Zeits.* **17**, 277 (1916); **18**, 291 (1917).

<sup>2</sup> A. W. Hull, *Phys. Rev.* **10**, 661 (1917); **17**, 571 (1921); Frank, *Inst. Jour.* **193**, 189 (1922). A. W. Hull and W. P. Davey, *Phys. Rev.* **17**, 549 (1921).

at every possible angle, and record the reflections on a photographic plate from all the faces simultaneously. The photograph thus obtained will have upon it all the reflected lines which can possibly be obtained from the crystal. The apparatus used in taking such photographs is essentially very simple, and is shown diagrammatically in Fig. 49. The rays from the target  $S$  of the X-ray tube pass through a filter  $F$  which renders the rays nearly homogeneous, and then traverse the sample  $C$  under investigation. The record is obtained either on a plate placed at  $P$  or on a cylindrical film with the sample  $C$  at the

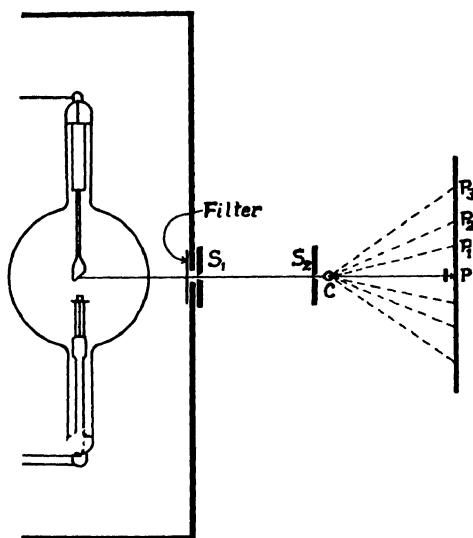

FIG. 49.

center. Figs. 50 and 51 show respectively photographs thus obtained when X-rays from a tube with a molybdenum target, after being filtered through an absorption screen of zirconium oxide, traverse fine crystals of silicon and magnesium.<sup>1</sup> The distinctly different pattern of lines obtained in the two cases correspond to the different distribution of the atoms in the two types of crystals.

It is clear that there is no way of telling directly which line

<sup>1</sup> These photographs are taken from Hull's paper, *Phys. Rev.* 10, 662 (1917).

on these photographs is due to the reflection from any particular face. This makes the analysis of the crystal structure somewhat more complex than when Bragg's large crystal method is used. For simple substances, however, the problem is not difficult. If the crystallographic data are known, there is a very limited number of possible arrangements for the points on the space



FIG. 50.

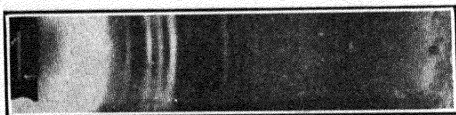

FIG. 51.

lattice, and the pattern of lines to be expected from each simple lattice may be calculated. The procedure then consists merely in finding to which pattern the observed lines belong. The fit must be exact, both in position and intensity, so that there is little chance for an error to occur.

Let us calculate the positions and intensities for certain simple lattices. The reflections will occur at all angles for which the condition

$$n\lambda = 2D_{hkl} \sin \theta$$

is satisfied, where  $D_{hkl}$  is the distance between the successive layers of atoms in the  $(hkl)$  plane. This distance may be calculated in the following manner. The distance of any point  $P(x, y, z)$  from a plane through  $O$  parallel to the plane  $XYZ$  (Fig. 52) is

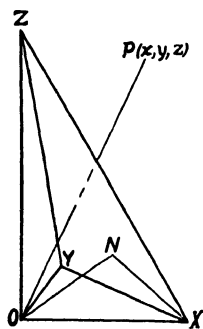

FIG. 52.

$$L = R \cos \widehat{PON}, \quad (4.03)$$

where  $R = \sqrt{x^2 + y^2 + z^2}$ , and  $\widehat{PON}$  is the angle between the line  $OP$  and the normal  $ON$  to the plane  $XYZ$ . If  $\alpha, \beta, \gamma$  are the direction cosines of  $ON$ , and  $\alpha', \beta', \gamma'$  those of  $OP$ , then

$$\cos \widehat{PON} = \alpha\alpha' + \beta\beta' + \gamma\gamma'.$$

But  $\alpha' = x/R$ ,  $\beta' = y/R$ ,  $\gamma' = z/R$ . Also, in the figure,  $\alpha = ON/OX$ ,  $\beta = ON/OY$ ,  $\gamma = ON/OZ$ , whence

$$\begin{aligned} \alpha : \beta : \gamma &= \frac{1}{OX} : \frac{1}{OY} : \frac{1}{OZ} \\ &= h : k : l, \end{aligned} \quad (4.03a)$$

by equations (4.01). Since  $\alpha^2 + \beta^2 + \gamma^2 = 1$ , we have,

$$\begin{aligned} \alpha &= h/\sqrt{h^2 + k^2 + l^2}, \\ \beta &= k/\sqrt{h^2 + k^2 + l^2}, \\ \gamma &= l/\sqrt{h^2 + k^2 + l^2}. \end{aligned} \quad \checkmark \quad (4.04)$$

It follows that

$$\begin{aligned} L &= \left\{ \frac{hx}{\sqrt{h^2 + k^2 + l^2}} + \frac{ky}{\sqrt{h^2 + k^2 + l^2}} + \frac{lz}{\sqrt{h^2 + k^2 + l^2}} \right\} \\ &= \frac{1}{\sqrt{h^2 + k^2 + l^2}} (hx + ky + lz).^1 \end{aligned} \quad (4.05)$$

If the atoms which act as diffracting centers are all alike, and are arranged on a simple cubic lattice of side  $a$ , then each time  $x$  increases by  $a/h$ ,  $y$  by  $a/k$  or  $z$  by  $a/l$  we shall have moved from one layer of atoms to another. Thus the grating constant will be,

$$D_{hkl} = a/\sqrt{h^2 + k^2 + l^2}. \quad (4.06)$$

For the cube centered lattice, the calculation is complicated by the fact that, if  $2a$  is the edge of the unit cube (Fig. 43*b*), for certain planes the numerator of equation (4.05) must be increased by only  $a$  and for others by  $2a$  in order to reach the

<sup>1</sup> The general expression for  $L$  for any set of axes and axial ratios is derived by Hull in the *Physical Review*, 10, 677 (1917).

next layer of atoms. Thus for the (100) or the (111) planes an increase of  $x$  by the distance  $a$  means a change from one atomic layer to the next; but for the (110) plane,  $x$  must change by  $2a$  to reach the next atomic layer. In general, for this lattice, it can be shown that if  $h + k + l$  is an odd number, the numerator of equation (4-05) must change by  $a$  to reach the next atomic layer, whereas if  $h + k + l$  is even, it must change by  $2a$ . Thus the grating constant for the centered cubic lattice is

$$D_{hkl} = (a \text{ or } 2a) / \sqrt{h^2 + k^2 + l^2}, \quad (4.07)$$

where the choice of  $a$  or  $2a$  is made according to the condition just stated.

Using this value of the grating space, we find that the wavelength  $\lambda$  will be reflected at the angles given by

$$\sin \phi/2 = \sin \theta = n\lambda/2D_{hkl}, \quad (4.08)$$

where  $\phi$  is the angle between the primary and the reflected beam. There will of course be a separate line for each different order of reflection  $n$ .

There will be a gradual decrease of intensity of the lines as the angle becomes greater, just as in the case of reflection from a single crystal. There will also be variations in the relative intensities of the different lines due to the fact that different numbers of the different types of planes are present. Thus, suppose we have calculated the distance between the planes of a cubic crystal for which  $h = g_1$ ,  $k = g_2$  and  $l = g_3$ , i.e., for the  $(g_1g_2g_3)$  plane. It is clear that the spacing of the planes will be the same whatever the order of the  $g$ 's or whatever their signs. It would be the same, for example, for the  $(32\bar{1})$  plane as for the  $(23\bar{1})$  plane, where  $\bar{1}$  indicates that the  $Z$  intercept is negative. If all the  $g$ 's are different and differ from zero, this makes 48 different planes whose spacing is identical. There are 6 planes with the same spacing as the (100) plane, corresponding to the 6 faces of a cube, 12 (110) planes, one for each cube edge, and 8 (111) planes, each for each cube corner.

The number and relative spacings of the different planes for the special case of the body centered cube are tabulated below.

As an example of the calculation, consider the (211) plane.  $2 + 1 + 1 = 4$ , which is even, whence, by equation (4-07),

$$D_{211} = 2 \cdot a / \sqrt{4 + 1 + 1} = 0.408 \times 2a.$$

There are 24 possible permutations of the indices, considering both positive and negative values, corresponding to 24 possible orientations of the crystal at which this grating space will be effective. This number thus measures the relative intensity of the lines.

TABLE IV-2\*

SPACING OF PLANES FOR CENTERED CUBIC LATTICE (DISTANCES IN TERMS OF EDGE  $2a$  OF UNIT CUBE = 1)

Indices of Form	Plane Families Belonging to Form	Spacing of Planes
110	12	.707
100	6	.500
211	24	.408
310	24	.316
111	8	.2885
321	48	.2672
411	24	.2358
210	24	.2234
332	24	.2132
431	48	.1960
510	24	.1960
521	48	.1826

\* More complete tables for this and other lattices are given by A. W. Hull, Phys. Rev. 10, 674 (1917).

#### 45. Structure of Molybdenum Crystals

We can now plot the positions of the lines to be expected from such a lattice in terms of  $\sin \phi/2$ , as in Fig. 53. In this diagram the height represents the estimated intensity, and the spacing is on an arbitrary scale. Fig. 54 shows the pattern obtained<sup>1</sup> when the line  $\lambda = .710\text{\AA}$  traverses powdered crystals

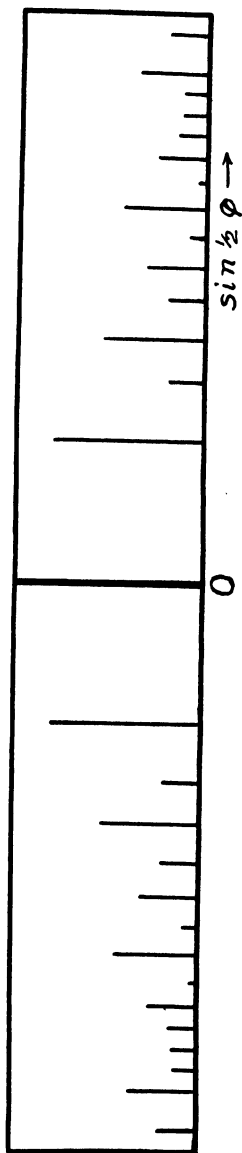

FIG. 53.

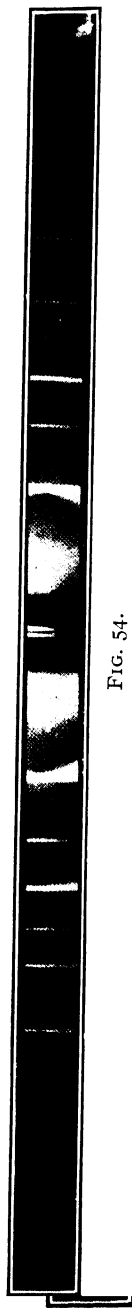

FIG. 54.

FIG. 54.

of molybdenum. It will be seen that the lines occur in positions corresponding exactly to the face-centered lattice, whereas the patterns obtained with silicon and magnesium (Figs. 50 and 51) do not agree with this diagram. From the angles at which the lines occur, we can calculate the value of  $a$  as  $1.57\text{\AA}$ , whence the side of the unit-centered cube is  $2a = 3.14\text{\AA}$ . The structure of the molybdenum crystal is thus completely determined.

Proceeding along similar lines it is found that the line pattern shown in Fig. 50 for silicon agrees exactly with that calcu-

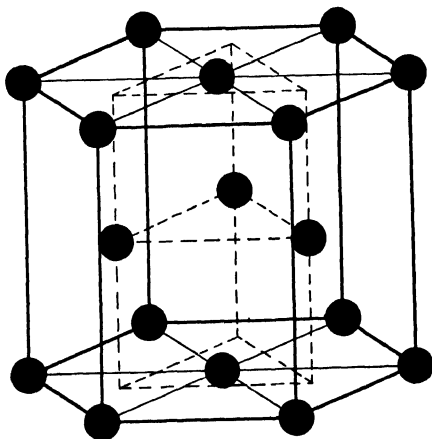

FIG. 55.

lated for a lattice like that of diamond, as shown in Fig. 47. The distance between the atoms is, however, greater, the grating space between the (111) planes being  $3.14 \times 10^{-8}$  cm. instead of  $2.05 \times 10^{-8}$  cm. as in the case of diamond. Magnesium is a hexagonal crystal, and the line pattern shown in Fig. 51 corresponds to the hexagonal close packed arrangement, such as shown in Fig. 55. The angles at which the lines appear indicate that the minimum distance between the magnesium atoms is  $3.22\text{\AA}$ .

While theoretically this powdered crystal method is not as powerful as the single crystal method, since the orientation of the crystals for the different lines is initially unknown, its great

convenience has made it used perhaps more than any other method of X-ray crystal analysis.

#### 46. Method of the Laue Spots

Laue's method of permitting a beam of X-rays containing a large number of wave-lengths to pass through a thin section of a crystal is the simplest X-ray method of obtaining crystallographic information. As usually used, it does not give direct measurements of the spacings for the different planes. It does, however, exhibit the symmetry of the crystal, and thus forms an independent check on the goniometric measurements, or when these are not available it may partly replace them. In the hands of Ewald<sup>1</sup> and Wyckoff,<sup>2</sup> this method has supplied all the necessary information to assign particular crystals to the correct space groups.

#### 47. Gnomonic Projection

The first step in the interpretation of the large number of spots obtained in a Laue photograph is to identify the indices of

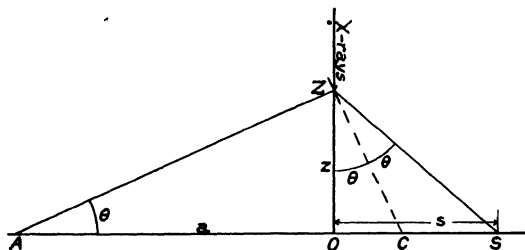

FIG. 56.

the planes producing them. This may be simply done by the method of gnomonic projection. Imagine a beam of X-rays traversing a section of a crystal placed at  $Z$  (Fig. 56), and being partially reflected along  $ZS$ , producing a spot on the photographic plate at  $S$ . If  $ZC$  represents the plane in the crystal re-

<sup>1</sup> P. P. Ewald, *Ann. der Phys.* **44**, 257 (1914).

<sup>2</sup> R. W. G. Wyckoff, *Ann. of Sci.* **50**, 317 (1920).

sponsible for this partial reflection, its angle of inclination  $\theta$  to the incident X-rays is given by the relation,

$$\frac{OS}{OZ} = \frac{s}{z} = \tan 2\theta. \quad (4.09)$$

Now draw a line from  $Z$ , perpendicular to  $ZC$ , intersecting the photographic plate at  $A$ . The point  $A$  is then the gnomonic projection of the observed spot  $S$ . It is on the line joining  $S$  and the central image  $O$ , and is at a distance from the center,

$$a = z \cot \theta. \quad (4.10)$$

The different points  $A$  can be rapidly plotted for each of the observed spots  $S$  by the help of a double ruler, such as shown in Fig. 57, in which the distances  $a$  corresponding to the distances  $s$  are calculated from equations (4.09) and (4.10).

If the direction  $ZO$  of the incident X-rays coincides with one of the axes of a cubic crystal, the coordinates of the point  $A$  determine at once the index of the plane responsible for the spot  $S$ . In Fig. 58, which is a 3-dimensional diagram of a Laue spot  $S$  and its gnomonic projection  $A$ , the reflecting plane in the crystal is seen to intersect the  $X$ ,  $Y$  and  $Z$  axes at distances  $x$ ,  $y$ , and  $z$  respectively. The Miller indices of the plane are thus in the ratio,

$$h : k : l = \frac{l}{x} : \frac{l}{y} : \frac{l}{z} = \frac{z}{x} : \frac{z}{y} : \frac{z}{z}$$

But by the construction of the figure it is evident that

$$\frac{z}{x} = \frac{x'}{z}, \quad \text{and} \quad \frac{z}{y} = \frac{y'}{z}$$

Thus

$$\begin{aligned} h : k : l &= \frac{x'}{z} : \frac{y'}{z} : \frac{z}{z} \\ &= x' : y' : z. \end{aligned} \quad (4.11)$$

Since  $z$ , the distance from the crystal to the plane, is known,<sup>1</sup> the coordinates  $x'$ ,  $y'$  of the point  $A$  thus give at once the Miller indices.

<sup>1</sup> In practice, the distance  $Z$  is usually taken as 5 cm.

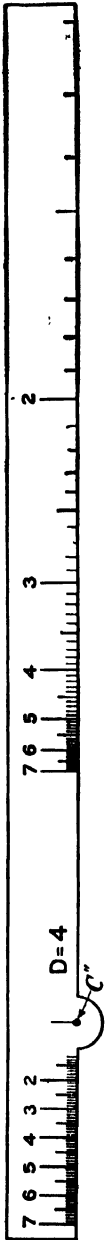

FIG. 57.

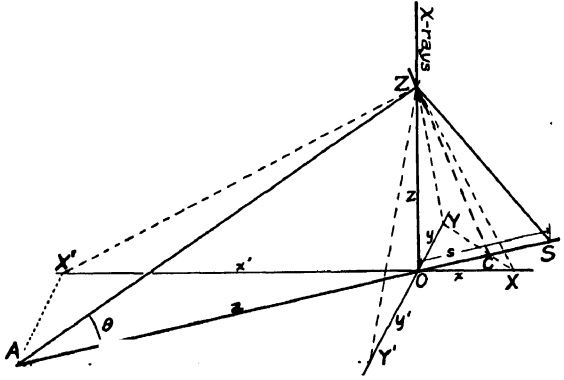

FIG. 58.

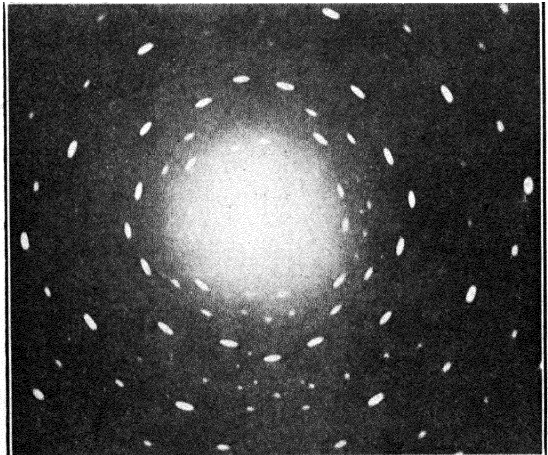

FIG. 59.

48. *Structure of Magnesium Oxide*

We may take as an example of the application of this method, the cubic crystal of magnesium oxide ( $\text{MgO}$ ). A photograph of its spot pattern, with the X-rays incident along the  $Z$  axis, taken by R. W. G. Wyckoff, is shown in Fig. 59. Fig. 60 shows these spots as an inset, and their corresponding gnomonic projections.

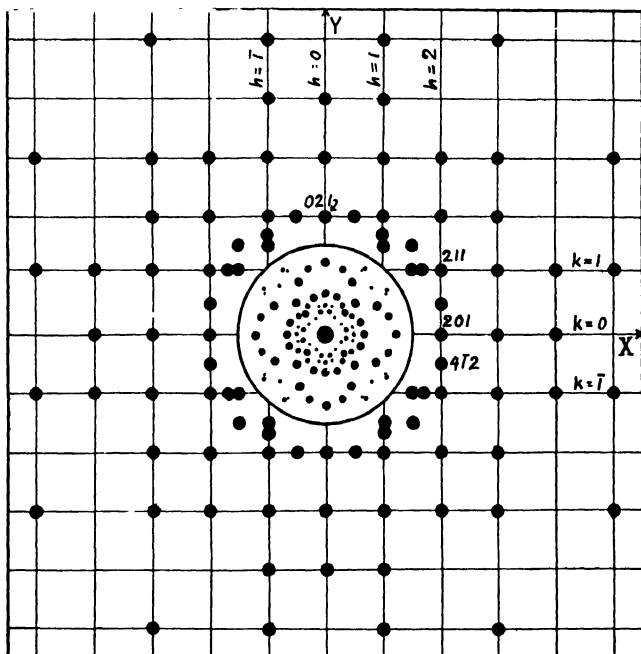

FIG. 60.

If we assume that magnesium oxide has the same type of structure as rock-salt, and if the ions are  $\text{Mg}^{++}$  and  $\text{O}^{--}$ , with 10 electrons to each ion, it will be approximately a simple cubic crystal. By equation (4.06), the grating constant for the  $(h, k, l)$  plane is

$$D_{hkl} = a / (h^2 + k^2 + l^2)^{1/2}, \quad (4.06)$$

where  $a$  is the edge of the unit cube. The wave-length of the rays producing an observed spot may now be calculated

from the relation

$$n\lambda = 2D_{hkl} \sin \theta. \quad (4.12)$$

It will be seen from Fig. 58, however, that

$$\sin \theta = z/\sqrt{x'^2 + y'^2 + z^2},$$

or by equations (4.11),

$$\sin \theta = l/\sqrt{h^2 + k^2 + l^2}. \quad (4.13)$$

Substituting this value for  $\sin \theta$  and the value given by equation (4.06) for  $D_{hkl}$  in equation (4.12), we get

$$n\lambda = 2al/(h^2 + k^2 + l^2). \quad (4.14)$$

In Fig. 60 we notice that the reflection from the (211) plane is intense. To calculate the corresponding wave-length from equation (4.14) we must know the value of  $a$ . If we take the molecular weight of MgO as 40.3, its density as 4.02 g. cm.<sup>3</sup>, and Avogadro's number as  $N = 6.06 \times 10^{23}$  per gram molecule, we have, assuming that the crystal has the rock-salt structure,  $a = (W/2N\rho)^{1/3} = 2.10A$ . For the (211) plane,  $h = 2$ ,  $k = 1$ , and  $l = 1$ . The wave-length of the first order reflection is thus given by equation (4.14) as  $\lambda = 2 \times 2.10/6 = 0.70A$ . Since the X-rays used in these experiments are usually intense over a wave-length range from about 0.3 to 0.9A, this result is satisfactory. A similar test for the other spots gives equally acceptable results,<sup>1</sup> whereas if other lattices had been assumed, some of the calculated wave-lengths would not have been within the range employed. Thus we infer that the crystal has the sodium chloride structure.

The chief disadvantage of this method is evidently that it affords no direct measurement of the grating space corresponding to each plane, so that a complete analysis can be effected only for the simplest crystals. This difficulty may be overcome

<sup>1</sup> Certain faint spots appear on Wyckoff's photographs, due to the first order reflections from planes such as (3, 2, 1) as calculated for a face-centered lattice, in which, according to the "rock-salt" structure, the layers of Mg and O atoms interfere. This is probably due to a different electronic distribution in the Mg and the O atoms.

by the method devised by Duane,<sup>1</sup> in which the potential applied to the X-ray tube is gradually reduced until the spot disappears. Having determined this critical potential  $V_m$ , the wave-length is calculated from the quantum relation,

$$\lambda = \frac{hc}{V_m e}, \quad (4.15)$$

and the grating space is then given by equation (4.12). In Duane's experiments the spots are detected by an ionization method, so that the potential at which each spot appears can readily be determined. When the wave-length is known from such measurements, the study of the Laue spots presents as much useful information as does the method of reflection from crystal faces. In fact the two methods become identical in principle.

The chief advantage of the Laue photographs in the study of crystal structure lies in the fact that from the many reflections from planes with complicated indices one can conveniently make intensity comparisons between the different planes. Using the reflection from crystal faces, such comparisons can be made only with considerable labor.

#### 49. *Crystal Structures of the Solid Elements*

It will be useful to present as a conclusion to this discussion a table of the structure of crystals of the elements that have been examined by the X-ray method. Most of the data included in these tables have been taken from a paper by A. W. Hull.<sup>2</sup> The remaining data have been gathered from miscellaneous sources. The number of crystalline compounds whose structure has been investigated by these methods is now so large that a complete table of them would be too long to include here. A summary of this work is given (to 1924) in the appendix of W. H. Bragg and W. L. Bragg's fourth edition of "X-rays and Crystal Structure," and in the second part of R. W. G. Wyckoff's "The Structure of Crystals."

<sup>1</sup> W. Duane, *Phys. Rev.* 1922.

<sup>2</sup> A. W. Hull, *J. Franklin Inst.* 193, 200 (1922).

TABLE IV-3  
CRYSTAL STRUCTURES OF ELEMENTS

Substance	Crystal Structure, Type of Lattice	Axial Ratio	Lattice Con- stant, Side of Elementary Cube or Hex- agon, <i>A</i>	Closest Approach of Atoms, <i>A</i>	Author- ity
Lithium.....	Body-centered cube	.....	3.50	3.03	I
Carbon:					
Diamond.....	Tetragonal cube	.....	3.56	2.06	2
Graphite.....	Hexagonal	2 75	2.47	1.50	3, I
Sodium.....	Body-centered cube	.....	4.30	3.72	I
Magnesium.....	Hexagonal close pack	1.624	3.22	3.22	I
Aluminum.....	Face-centered cube	.....	4.05	2.86	I, 4
Silicon.....	Tetrahedral cube	.....	5.43	2.35	5, I
Sulphur.....	Orthorhombic	.....	.....	.....	20
Potassium.....	Body-centered cube	.....	5.20	4.50	21
Calcium.....	Face-centered cube	.....	5.56	3.93	6
Titanium.....	Hexagon close pack	1.59	2.97	2.90	7
Vanadium.....	Body-centered cube	.....	3.04	2.64	8
Chromium.....	Body-centered cube	.....	2.895	2.508	9
Iron.....	Body-centered cube	.....	2.86	2.48	I
	Face-centered cube	.....	3.60	2.54	10, 19
Cobalt.....	Face-centered cube	.....	3.554	2.514	9
	Hexagon close pack	1.633	2.514	2.514	9
Nickel.....	Face-centered cube	.....	3.540	2.505	I, 9, II
Copper.....	Face-centered cube	.....	3.60	2.54	12
Zinc.....	Hexagon close pack	1.860	2.670	{ 2.920 2.670 }	9
Germanium.....	Tetrahedral cube	.....	5.61	2.43	22
Zirconium.....	Hexagon close packed	1.59	3.23	{ 3.18 3.24 }	7
Molybdenum.....	Body-centered cube	.....	3.143	2.720	9
Ruthenium.....	Hexagonal close pack	1.59	2.686	{ 2.640 2.686 }	9
Rhodium.....	Face-centered cube	.....	3.820	2.700	9
Palladium.....	Face-centered cube	.....	3.950	2.795	9
Silver.....	Face-centered cube	.....	4.060	2.876	13
Cadmium.....	Hexagonal close pack	1.89	2.960	{ 3.28 2.96 }	9
Indium.....	Face-centered tetragonal	1.06	4.58	{ 3.33 3.24 }	9
Tin (gray).....	Tetrahedral cube	.....	6.46	2.80	11
Antimony.....	Rhombohedral hexagonal	2.647	4.28	{ 2.87 3.02 }	15
Cerium.....	{ Hexagonal close pack	.....	3.65	3.64	7
	Face-centered cube	1.62	5.12	3.64	7
Tantalum.....	Body-centered cube	.....	3.272	2.833	9
Tungsten.....	Body-centered cube	.....	3.150	2.726	16, 9
Osmium.....	Hexagonal close pack	1.59	2.714	{ 2.66 2.72 }	7
Iridium.....	Face-centered cube	.....	3.805	2.690	9
Platinum.....	Face-centered cube	.....	3.930	2.780	9
Gold.....	Face-centered cube	.....	4.08	2.88	17
Mercury.....	Tetrahedral hexagonal	1.88	3.84	.....	23
Lead.....	Face-centered cube	.....	4.92	3.48	17
Bismuth.....	Rhombohedral hexagonal	.....	4.54	{ 3.11 3.47 }	18
Thorium.....	Face-centered cube	.....	5.04	3.54	11, 7

REFERENCES FOR TABLE IV-3

1. Hull, Phys. Rev. 10, 661 (1917).
2. W. H. and W. L. Bragg, Proc. Roy. Soc. A. 89, 277.
3. Debye and Sherrer, Physik. Z. 18, 291 (1917).
4. P. Sherrer, Physik. Z. 19, 23 (1918).
5. Debye and Sherrer, Physik. Z. 17, 277 (1916).
6. Hull, Phys. Rev. 17, 42 (1921).
7. Hull, Phys. Rev. 18, 88 (1921).
8. Hull, Franklin Inst. J. 193, 200 (1922).
9. Hull, Phys. Rev. 17, 571 (1921).
10. A. Westgren, Z. f. Physik, Chem. 98, 182 (1921).
11. Bohlin, Ann. d. Phys. 61, 421 (1920).
12. W. L. Bragg, Phil. Mag. 28, 355 (1914).
13. Vegard, Phil. Mag. 31, 86 (1916).
14. Bijl and Kolkmeijer, Proc. Roy. Akad. Amsterdam, 21, 501 (1919).
15. James and Tunstall, Phil. Mag. 40, 233 (1920).
16. P. Debye, Physik. Z. 18, 483 (1917).
17. Vegard, Phil. Mag. 32, 65 (1916).
18. James, Phil. Mag. 40, 233 (1920).
19. Bain, Chem. Met. Eng. 25, 657 (1921).
20. W. H. Bragg and W. L. Bragg, X-Rays and Crystal Structure (1924), Chap. XIV.
21. L. W. McKeehan, cf. Bragg, op. cit., p. 163.
22. Kolkmeijer, cf. Bragg, op. cit. p. 163.
23. Aminoff, op. cit., p. 163.

## CHAPTER V

### INTENSITY OF THE REFLECTION OF X-RAYS FROM CRYSTALS

#### I. INTRODUCTION

##### 50. *Reflecting Power as a Function of Electron Distribution*

We have seen in the last chapter that the higher orders of a given spectrum line diminish rapidly in intensity. An investigation by W. L. Bragg<sup>1</sup> and W. H. Bragg,<sup>2</sup> in connection with their early work on the reflection of X-rays, revealed the fact that the intensity of the lines varies in much the same manner for the different faces of a crystal, when the successive layers of atoms are similar to each other. A summary of the work of this character on crystals of rock-salt is shown in Fig. 61. This shows the intensities of the reflected lines observed at different angles when the rhodium  $K\alpha$  line is reflected from the various faces of a rock-salt crystal, as measured by W. L. Bragg, James and Bosanquet.<sup>3</sup> The positions of the reflections from the different faces are plotted in the terms of  $\sin \theta / \sin \theta_{100}$ , where  $\theta_{100}$  is the angle at which the first order reflection from the (100) face occurs. In labeling the different lines, the indices (222) have been used to indicate the second order reflection from the (111) plane, and similarly for the other lines. The height of each line is proportional to the area under a curve representing the line plotted as in Fig. 44, and may be called the "integrated reflection." When measured in this way, the relative intensity of any two lines is independent of the width of the slits used and of the accuracy of setting on the center of the line.

It will be noticed that for the faces with even indices, in which cases all the atoms co-operate in their scattering, the tops

<sup>1</sup> W. L. Bragg, Proc. Roy. Soc. A **89**, 468 (1914).

<sup>2</sup> W. H. Bragg, Phil. Mag. **27**, 881 (1914).

<sup>3</sup> W. L. Bragg, James and Bosanquet, Phil. Mag. **41**, 309 (1921).

of the lines fall upon a smooth curve. A similar curve connects also the lines reflected from the planes with odd indices, in which case the rays scattered by the sodium atoms interfere with those scattered by the chlorine atoms. It has been shown

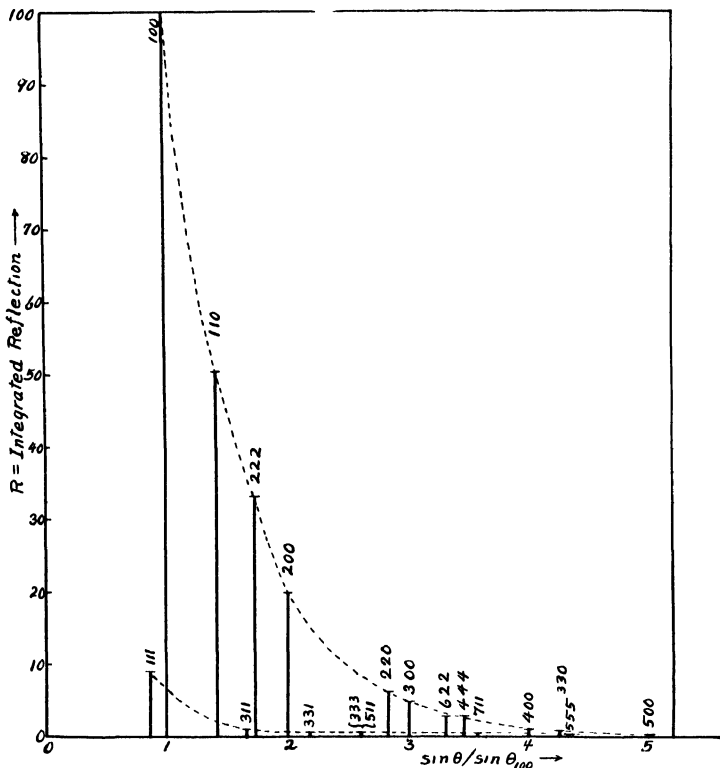

FIG. 61.

by W. H. Bragg<sup>1</sup> that the smooth curve joining the tops of these lines is represented approximately by the expression,

$$C \frac{1 + \cos^2 2\theta}{\sin^2 \theta} e^{-B \sin^2 \theta}. \quad (5.01)$$

In this expression the constant  $C$  depends upon the energy in the incident beam, the wave-length of the X-rays and the nature of the crystal. The factor  $(1 + \cos^2 2\theta)$  is the polarization factor which appears in expression (3.04), and the factor  $e^{-B \sin^2 \theta}$  is in-

<sup>1</sup> W. H. Bragg, *Phil. Mag.* 27, 881 (1914).

cluded to take account of the thermal agitation of the atoms, as will be discussed below. The factor  $\sin^2\theta$  in the denominator is an arbitrary one, chosen to make the calculated reflection fit the experimental data.

It is well known that if the width of the lines ruled on a diffraction grating is comparable with the distance between the successive lines, the intensity of the higher orders of the spectrum rapidly diminishes. Similarly, in the case of the reflection of X-rays from a crystal, if the thickness of a layer of atoms as determined by the distribution of the electrons is comparable with the distance between the successive atomic layers, the higher orders of reflection should fall off rapidly in intensity. The intensity of the reflection of X-rays from crystals as a function of the distribution of the electrons was first examined theoretically by C. G. Darwin,<sup>1</sup> who showed that if all the electrons were in the mid-planes of their atomic layers the integrated reflection should be inversely proportional to  $\sin \theta \cos \theta$  instead of to  $\sin^2\theta$  as indicated by equation (5.01). There thus remains a factor in the experimental reflection formula of about  $1/\tan \theta$ , which is presumably due to the fact that the scattering electrons are not in the mid-planes of their atomic layers, in other words, that the size of an atom is comparable with the distance from one atom to the next. In the present chapter we shall review the progress which has been made in determining from a study of X-ray reflection the distribution of the electrons within the atoms.

## 2. THEORY OF THE INTENSITY OF CRYSTALLINE REFLECTION

### 51. *Perfect and Irregular Crystals*

The investigation from the theoretical standpoint of the intensity of the X-rays reflected from crystals has occupied the attention of a number of writers.<sup>1</sup> Comparison of these theories

<sup>1</sup> P. Debye, *Ann. d. Physik*, **43**, 49 (1914). C. G. Darwin, *Phil. Mag.* **27**, 315 and 675 (1914); **43**, 800 (1922). W. H. Bragg, *Phil. Trans.* **215**, 253 (1915). A. H. Compton, *Phys. Rev.* **9**, 29 (1917). W. L. Bragg, James and Bosanquet, *Phil. Mag.* **41**, 309 (1921). H. A. Wilson, *Phys. Rev.* **18**, 396 (1921). P. P. Ewald, *Phys. Zeitschr.* **22**, 29 (1925). W. Duane, *Proc. Nat. Ac. Sci.* **11**, 489 (1925).

with experiment has shown that the crystals which we ordinarily use are by no means perfect. On the other hand, there is enough regularity in the crystal structure so that when turned near the angle of maximum reflection the atoms inside the crystals are partially shielded by the reflection of the X-rays from the surface layers of atoms. We may distinguish between the two limiting cases of a crystal so perfect that we can treat it as a perfectly regular arrangement of atoms, and the case of a crystal so irregularly formed that the components which are sensibly perfect are so small that the upper layers of atoms do not appreciably shield the lower layers from the incident X-rays

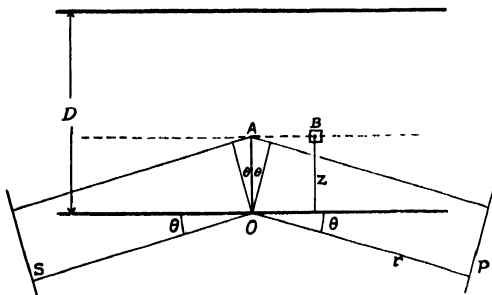

FIG. 62.

when the crystal is so oriented that it gives the maximum reflection. It is found that a good piece of calcite approximates a perfect crystal, whereas rock-salt is more nearly what we may describe as an "irregular crystal."

No real crystal lies strictly in either category. It is easier, however, to prepare an approximately "irregular" crystal than to prepare one that is nearly perfect—it can be made irregular by grinding to a powder if other methods are ineffective. The most important case is therefore that of the irregular crystal. We can examine this problem by considering first the intensity of the diffracted beam from a very small crystal, and we can then find the effect of groups of such components in the form of crystalline aggregates or of powdered crystals.

### 52. Diffraction by a Very Small Crystal

Let us consider the amplitude of the wave scattered by a single electron placed at some point  $O$  in the mid-plane of a layer of atoms (Fig. 62). For convenience we shall first take an incident wave whose electric vector  $E_s$  is perpendicular to the plane  $SOP$ . If this vector is represented by

$$E_s = A_s \cos (pt + \delta), \quad (5.02)$$

then, by equation 3.10, the resulting field at  $P$  is

$$E_o = A_o \cos (pt + \Delta), \quad (5.03)$$

where

$$A_o = A_s e^2 / mrc^2, \quad (5.04)$$

and

$$\Delta = \delta - pr/c.$$

If all the electrons in an atom were exactly in the midplane of the atomic layer, and if the glancing angle  $\theta$  is given by the relation

$$n\lambda = 2D \sin \theta,$$

all the rays scattered to  $P$  would be in the same phase, and the resulting amplitude would be the sum of the amplitudes due to the individual electrons. But if an electron is at a distance  $z$  from the middle of the atomic layer to which it belongs, the path of the ray scattered to  $P$  is increased by  $2z \sin \theta$ , and its contribution to the amplitude of the ray scattered by the atom is accordingly

$$A_e = A_o \cos \left( \frac{2\pi}{\lambda} 2z \sin \theta \right).$$

We may express the probability that any electron will be at a height between  $z$  and  $z + dz$  above the mid-plane of the layer of atoms to which it belongs as  $p(z)dz$ . The probable contribution to the amplitude by any electron is then,

$$\overline{A}_e = A_o \int_{-a}^a p(z) \cos \left( \frac{4\pi z}{\lambda} \sin \theta \right) dz, \quad (5.05)$$

where  $a$  is the maximum possible distance of an electron from its atomic layer. If there are a number  $Z$  electrons in each atom, the amplitude due to an atom is thus

$$Z\bar{A}_e = A_0 F, = F A_0 \frac{e^2}{mrc^2}, \quad (5.06)$$

where

$$F \equiv Z \int_{-a}^a p(z) \cos\left(\frac{4\pi z}{\lambda} \sin \theta\right) dz. \quad (5.07)$$

The quantity  $F$  is called the "structure factor" of the atom.

Let us now imagine a volume element  $dx dy dz$  of a simple cubic crystal composed of a single kind of atom. This crystal element is large enough to contain a large number of atoms but is so small that when oriented near the correct angle the phases of the rays diffracted by all the atoms are sensibly the same except for multiples of  $2\pi$  for different atomic layers. If there are  $n$  atoms per unit volume, the amplitude of the ray diffracted by such a volume element is, in view of equation (5.06),

$$dA = nA_0 F dx dy dz. \quad (5.08)$$

Let us suppose for convenience that each of the very small crystals has the form of a rectangular parallelepiped whose edges are  $\delta x$ ,  $\delta y$  and  $\delta z$ . We have assumed that the dimensions of this crystal are so small that the rays are not appreciably absorbed on passing through it, and it follows that the phase of the wave diffracted by the whole crystal is the same as that from an atom at the center of the crystal. We shall therefore take this point as the origin of coordinates. Consider the case when the ray is incident (as in Fig. 63) at a glancing angle  $\theta + \alpha$ , where  $\sin \theta \equiv n\lambda/2D$ , and is diffracted at the angle  $\theta + \beta$ ,  $\gamma$  where the angle  $\gamma$  is measured in a plane perpendicular to  $SOP$ . A ray diffracted from a crystal element at a point  $x, y, z$  in the crystal traverses a path which is longer than that from an atom at  $O$  by

$$x(\alpha - \beta) \sin \theta + y\gamma + z\{2 \sin \theta + (\alpha + \beta) \cos \theta\},$$

if second order terms in  $\alpha$ ,  $\beta$  and  $\gamma$  are neglected. Considering the manner in which we defined  $dA$  (equation 5.08), it will be seen that the diffracted rays from all parts of the crystal are in the same phase, except for integral multiples of  $2\pi$ , when the difference between their paths is  $2z \sin \theta$ . Neglecting multiples

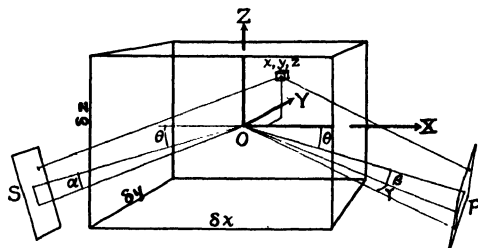

FIG. 63.

of  $2\pi$ , the phase of difference between the rays from  $x$ ,  $y$ ,  $z$  and from  $O$  is accordingly

$$\delta = \frac{2\pi}{\lambda} \{x(\alpha - \beta) \sin \theta + y\gamma + z(\alpha + \beta) \cos \theta\}. \quad (5.09)$$

The amplitude of the ray reflected by the whole little crystal is (by eq. 5.08),

$$\begin{aligned} A_1 &= nA_0F \int_{-\delta z/2}^{\delta z/2} \int_{-\delta y/2}^{\delta y/2} \int_{-\delta x/2}^{\delta x/2} \cos \delta \cdot dx dy dz \\ &= nA_0F \cdot \frac{\sin \xi}{\xi} \frac{\sin \eta}{\eta} \frac{\sin \zeta}{\zeta} \delta x \delta y \delta z, \end{aligned} \quad (5.10)$$

where

$$\xi = \pi(\beta - \alpha) \frac{\delta x}{\lambda} \sin \theta,$$

$$\eta = \pi\gamma \frac{\delta y}{\lambda},$$

$$\zeta = \pi(\alpha + \beta) \frac{\delta z}{\lambda} \cos \theta.$$

We have seen that the intensity of a wave the amplitude of whose electric vector is  $A_1$  is

$$I_1 = cA_1^2/8\pi. \quad (5.11)$$

Substituting the value of  $A_1$  found above we should thus obtain the intensity of the ray diffracted in the direction  $\beta, \gamma$ . However, we usually measure with an ionization chamber the rays diffracted at all angles  $\beta, \gamma$  at which any appreciable intensity is observed, *i.e.*, effectively,

$$P_1 = \int_{-\infty}^{\infty} r d\beta \int_{-\infty}^{\infty} r d\gamma I_1. \quad (5.12)$$

This is the "power," or energy per unit time, diffracted by the crystal when the incident rays strike at an angle  $\theta + \alpha$ . When we determine the energy represented by the area under a spectrum line, we sum up the power of the diffracted ray for all angles  $\alpha$  at which the intensity of the diffracted ray is measurable. A common procedure for doing this is to rotate the crystal with a slow uniform angular velocity  $\omega$  past the angle  $\theta$ . The angle  $\alpha$  then lies between  $\alpha$  and  $\alpha + d\alpha$  for a time  $d\alpha/\omega$ , and the total energy diffracted near the angle  $\theta$  as the crystal is rotated is

$$W_1 = \int_{-\infty}^{\infty} P_1 \frac{d\alpha}{\omega}. \quad (5.13)$$

Substituting the value of  $P_1$  given by equations (5.12), (5.11) and (5.10), this expression becomes:

$$W_1 = \frac{cr^2}{8\pi\omega} n^2 A_0^2 F^2 \delta x^2 \delta y^2 \delta z^2 \int_{-\infty}^{\infty} \int_{-\infty}^{\infty} \int_{-\infty}^{\infty} \frac{\sin^2 \{h(\beta - \alpha)\}}{h^2(\beta - \alpha)^2} \frac{\sin^2 \{k\gamma\}}{(k\gamma)^2} \frac{\sin^2 \{l(\alpha + \beta)\}}{l^2(\alpha + \beta)^2} d\alpha d\beta d\gamma,$$

where

$$h = \pi \frac{\delta x}{\lambda} \sin \theta, \quad k = \pi \frac{\delta y}{\lambda}, \quad l = \pi \frac{\delta z}{\lambda} \cos \theta.$$

The portion of this expression within the integral signs has the value  $\pi^3/2hkl$ , whence

$$\begin{aligned} W_1 &= \frac{cr^2 n^2 A_0^2 F^2 \lambda^3}{8\pi\omega 2 \sin \theta \cos \theta} \delta x \delta y \delta z \\ &= \frac{c}{8\pi} A_0^2 \frac{1}{\omega} \frac{e^4}{m^2 c^4} \frac{n^2 F^2 \lambda^3}{\sin 2\theta} \delta V, \end{aligned}$$

since  $A_0 = A_s e^2 / mrc^2$ , where  $\delta V = \delta x \delta y \delta z$ . But the intensity of the rays incident on the crystal is  $I_s = \frac{c}{8\pi} A_s^2$ . Thus

$$W_1 = \frac{I_s e^4}{\omega m^2 c^4} \frac{n^2 F^2 \lambda^3}{\sin 2\theta} \delta V. \quad (5.14)$$

This represents the total energy reflected by the crystal when illuminated by X-rays polarized with the electric vector perpendicular to the plane of reflection, when the crystal is turned past the angle of maximum reflection  $\theta$  at a uniform angular velocity  $\omega$ .

If we had considered an incident ray whose electric vector lies in the plane of reflection, it is clear that the electric vector of each diffracted ray would have been reduced by the factor  $\cos 2\theta$ , so that the intensity, and hence also the total reflected energy would have been reduced by the factor  $\cos^2 (2\theta)$ . Thus if  $W_2$  is the energy of this component of the reflected beam, since the intensity of each component of the unpolarized incident beam is equal on the average to half the whole incident intensity  $I$ ,

$$W_2 = W_1 \cos^2 2\theta,$$

and the whole reflected energy is

$$\begin{aligned} W &= W_1 + W_2 = W_1(1 + \cos^2 2\theta) \\ &= \frac{I}{2\omega} \frac{e^4}{m^2 c^4} n^2 F^2 \lambda^3 \frac{1 + \cos^2 2\theta}{\sin 2\theta} \delta V. \end{aligned} \quad (5.15)$$

We may thus write for the integrated reflection,

$$\left. \begin{aligned} \frac{W\omega}{I} &= \frac{1}{2} n^2 \lambda^3 F^2 \frac{e^4}{m^2 c^4} \frac{1 + \cos^2 2\theta}{\sin 2\theta} \delta V, \\ &\equiv Q \delta V. \end{aligned} \right\} \quad (5.16)$$

In this expression  $W$  is the total energy diffracted by a small crystal of volume  $\delta V$ , as it is turned past the angle  $\theta$  with a uniform angular velocity  $\omega$ .  $I$  is the intensity of the incident (unpolarized) beam,  $n$  is the number of atoms per unit volume of

the crystal,  $\lambda$ ,  $e$ ,  $m$  and  $c$  have their usual values, and  $F$  is the "structure factor" defined by equation (5.07).

No mention has been made of the effect of the thermal agitation of the atoms in the crystals. Debye and Darwin have tried to take account of this motion by introducing into equation (5.16) a factor of the form  $e^{-B \sin^2 \theta}$ , where  $B$  depends upon the temperature and the nature of the crystal. As we shall see below (§ 55), experiment does not give great confidence in the applicability of these calculations to our problem. The structure factor  $F$ , since it depends upon the distances of the electrons from the middle of the atomic layers, will take account of the thermal displacements of the atoms, and in view of the uncertainties of the thermal calculations it is probably wiser to leave our expression for the reflected energy in its present form.

### 53. *Diffraction by an Irregular Crystal*

In order that a crystal may be so small that the absorption within the crystal is negligible, it must be too minute to reflect an X-ray beam of measurable intensity. To compare the results of our calculation with experiment we must therefore consider the effect of such tiny crystals in large aggregations. Two cases are of importance, an imperfect crystal composed of such little crystals oriented at random over a range of angles so narrow as to retain many of the characteristics of a single crystal, and a wholly random composite of little crystals such as are used in experiments with powdered crystals.

### 54. *Case of Transmission of Diffracted Rays*

Let us consider first the case of the diffraction of X-rays as they pass through an irregular crystal, as illustrated in Fig. 64. We suppose that the phases of the rays from the component little crystals are random, so we can calculate the energy in the reflected beam by taking the sum of that reflected from each of the component crystals. If  $\mu$  is the absorption coefficient of the X-rays in the crystal, since the total path of the ray in the crystal before and after reflection is  $h \sec \theta$ , all the rays are re-

duced in intensity by the factor  $e^{-\mu h \sec \theta}$ . But the volume irradiated by the X-rays is  $Ah \sec \theta$ , where  $A$  is the area of the slit which limits the incident X-rays. The energy in the diffracted ray is thus given by (cf. equation (5.16))

$$\frac{W\omega}{I} = Q.Ah \sec \theta e^{-\mu h \sec \theta},$$

where  $I$  is the intensity of the rays as they pass through the slit, and  $Q$  is defined by equation (5.16). This quantity is a maximum when  $h \sec \theta = 1/\mu$ , that is when the crystal is thick enough to reduce the intensity of the transmitted rays to  $1/e$  of that of the incident rays. The reflected energy is then given by

$$\left(\frac{W\omega}{I}\right)_{\max.} = \frac{Q.A}{e\mu}, \quad (5.17)$$

where  $e$  is the Napierian base.

In performing the experiment one can more conveniently compare the energy in the diffracted beam with the energy per unit time, or power, of the rays which traverse the crystal. This transmitted power is

$$P = IAe^{-\mu h \sec \theta}.$$

Thus

$$\frac{W\omega}{P} = Qh \sec \theta, \quad (5.18)$$

gives the ratio of the energy  $W$  in the diffracted ray to the power  $P$  in the transmitted ray, when the crystal is turned with an angular velocity,  $\omega$ .

### 55. Case of Reflection of Diffracted Rays

When X-rays are "reflected" from the face of a crystal, as in Fig. 65, they really enter to some depth  $z$  and are then dif-

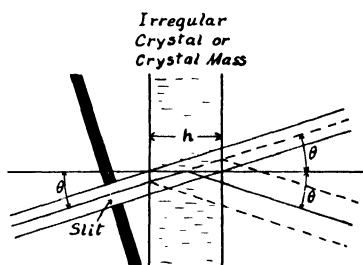

FIG. 64.

fracted out again. The diffracted rays from a volume  $dV$  at this depth are reduced in intensity, due to absorption, by the factor

$$e^{-\mu \cdot 2z \csc \theta}.$$

The energy in the diffracted ray from a thick crystal is thus given by

$$\frac{W_\omega}{I} = Q \int_0^\infty A \csc \theta dz e^{-2\mu z \csc \theta},$$

where again  $A$  is the area of the slit limiting the incident beam. On integration this becomes,

$$\frac{W_\omega}{I} = \frac{QA}{2\mu}. \quad (5.19)$$

On comparing this result with equation (5.17), we see that the energy "reflected" from a crystal face is greater than the maximum energy obtained by the transmission method by a factor of  $e/2 = 1.36$ .

In this case also one usually measures the intensity  $I$  of the incident beam by determining the power  $P = AI$  transmitted through the slit when the crystal is removed. We then have

$$\frac{W_\omega}{P} = \frac{Q}{2\mu}. \quad (5.20)$$

This represents the "integrated reflection" as plotted in Fig. 61.

It will be noticed that this expression involves the absorption coefficient  $\mu$ , whereas equation (5.18) does not. If, as is usually the case, the crystal is sufficiently regular to make the extinction due to reflection at the angle  $\theta$  comparable with the ordinary absorption, the appropriate value of  $\mu$  is difficult to determine. Under such conditions equation (5.18) can be compared with experiment more reliably than can equation (5.20).

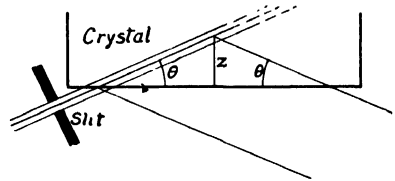

FIG. 65.

56. *Diffraction by Powdered Crystals*

A powdered crystal may be considered as an aggregation of very small crystals whose orientation is wholly random. Imagine that  $ON$  is the normal to a plane in the crystal of the type which gives a reflection maximum at the angle  $\theta$ . It will be seen from Fig. 66 that the probability that this normal will

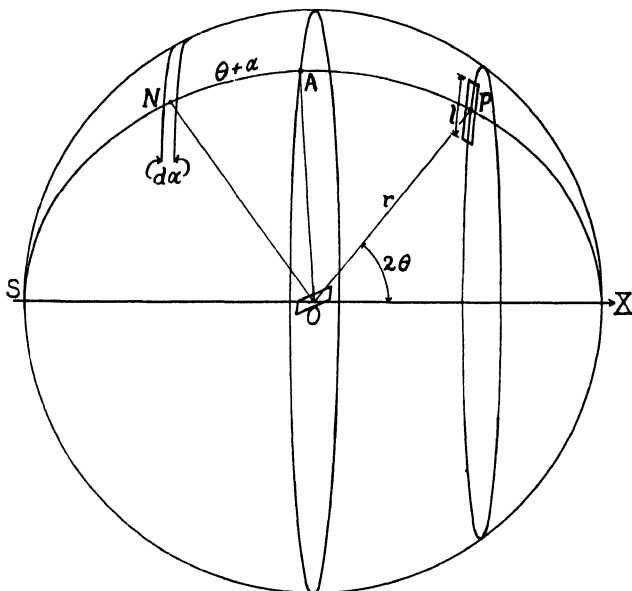

FIG. 66.

be so oriented that the glancing angle of incidence lies between  $\theta + \alpha$  and  $\theta + \alpha + d\alpha$  is

$$\frac{2\pi \cos(\theta + \alpha)d\alpha}{4\pi} = \frac{1}{2} \cos \theta d\alpha,$$

since  $\alpha$  is small compared with  $\theta$ . If there are a number  $p$  of planes of this type in the crystal, e.g., for the  $(100)$  planes there are  $p = 6$  cube faces, for  $(110)$ ,  $p = 12$ , for  $(111)$   $p = 8$ , etc. (cf. p. 107, Table IV-2), the probability that some one plane will have this orientation is thus

$$\frac{1}{2} p \cos \theta d\alpha.$$

If  $P_1$  is the power diffracted by the crystal for a glancing angle of incidence  $\theta + \alpha$  (eq. 5.12), the probable power diffracted for a random orientation is therefore

$$\bar{P}_1 = \int_{-\infty}^{\infty} P_1 \cdot \frac{1}{2} p \cos \theta d\alpha.$$

These integration limits can be used since the diffracting power is negligible except for small values of  $\alpha$ . Substituting from equation (5.12) we have thus,

$$\bar{P}_1 = \frac{1}{2} p \cos \theta \int_{-\infty}^{\infty} \int_{-\infty}^{\infty} \int_{-\infty}^{\infty} r^2 I_1 d\alpha d\beta d\gamma,$$

which, by comparison with (5.13) and (5.14), becomes

$$\bar{P}_1 = \frac{1}{4} I_s \frac{p e^4}{m^2 c^4} \frac{n^2 F^2 \lambda^3}{\sin \theta} \delta V.$$

On introducing the polarization factor  $\frac{1}{2}(1 + \cos^2 2\theta)$  as before, we obtain <sup>1</sup>

$$\begin{aligned} \frac{\bar{P}}{I} &= \frac{1}{8} p n^2 F^2 \lambda^3 \frac{e^4}{m^2 c^4} \frac{1 + \cos^2 2\theta}{\sin \theta} \delta V \\ &= Q \cdot \frac{1}{2} p \cos \theta \delta V. \end{aligned} \quad (5.21)$$

The quantity  $\bar{P}$  is the probable power diffracted in a cone of semi-apex angle  $2\theta$  (Fig. 66). If the rays are measured by an ionization chamber at a distance  $r$  with a slit of a length  $l$  which is short compared with  $r \sin 2\theta$ , and if the width of the slit is great enough to take in all the angles  $\alpha$  at which any measurable power is diffracted, then the power entering the chamber is  $P_s = \bar{P} l / 2\pi r \sin 2\theta$ . Also, if  $A$  is the area of the slit limiting the primary beam, the power of this beam is  $P = AI$ . Thus the ratio of the power of the diffracted beam entering the ionization chamber to that of the primary beam is

$$\frac{P_s}{P} = \frac{l}{2\pi A r \sin 2\theta} \cdot Q \frac{1}{2} p \cos \theta \delta V = Q \cdot \frac{p l \delta V}{8\pi A r \sin \theta}. \quad (5.22)$$

<sup>1</sup> This is the same as Darwin's equation (10.4), Phil. Mag. 43, 827 (1922).

Probably the most satisfactory method of comparing the intensity of the primary rays and the rays diffracted by powdered crystals is that pictured in Fig. 64. The little crystals are molded into a plate of thickness  $h$ , which is turned at half the angular rate of the ionization chamber, so that the absorption is the same for the primary and the diffracted rays. In this case the total volume exposed to the X-rays is  $Ah \sec \theta$ . But there are interstices between the little crystals, so that the volume of the crystals traversed by the X-rays is

$$Ah \sec \theta \cdot \frac{\rho'}{\rho},$$

where  $\rho'$  is the density of the crystalline mass, and  $\rho$  is the density of the individual crystals. Thus the ratio of the power of the rays scattered to the ionization chamber to the power of the primary rays that have traversed the crystal mass is

$$\begin{aligned} \frac{P_s}{P} &= Q \frac{pl}{8\pi Ar \sin \theta} \cdot \frac{\rho'}{\rho} Ah \sec \theta \\ &= Q \frac{plh\rho'}{4\pi r\rho \sin 2\theta} \cdot 1 \end{aligned} \quad (5.23)$$

If we calculate in a similar manner the power of the rays "reflected" from a thick plate of powdered crystals set as in Fig. 65, we find

$$\frac{P_s}{P} = Q \frac{p}{16\pi} \frac{l}{\mu r} \frac{\rho'}{\rho} \frac{1}{\sin \theta}. \quad (5.24)$$

In these expressions,  $p$  is the number of surfaces in a crystal of the type considered,  $l$  is the height of the slit of the ionization chamber,  $h$  is the thickness of the crystal mass,  $r$  is the distance from the crystal mass to the ionization chamber,  $\rho'$  is the density of the crystal mass,  $\rho$  is the density of the individual crystals,  $Q$  is defined by equation (5.16),  $\theta$  is the glancing angle of incidence of the X-rays on the crystal.  $\mu$  is the absorption coefficient in the crystal mass.

## 3. MEASUREMENTS OF INTENSITY OF DIFFRACTED X-RAYS

57. *Measurements on Powdered Crystals*

In deriving these formulas for the reflected X-rays we have supposed that each of the component crystals is so small that the intensity of the incident rays is not appreciably reduced on traversing the crystal. We should expect this condition to be most nearly satisfied in the case of the diffraction by finely powdered crystals. Because, however, of the low intensity of the rays diffracted by powdered crystals, very few ionization measurements of their energy have been made.

Bearden, working in the author's laboratory, has nevertheless recently succeeded in measuring the  $K\alpha$  line of molybdenum after it has been diffracted by powdered crystals of rock-salt.<sup>1</sup> The crystals were ground in a mortar to an impalpable powder, and were then molded into a thin flat plate. This plate was placed in the position of the crystal on a Bragg spectrometer and were traversed by the X-rays in the manner indicated in Fig. 64. The rays incident upon the plate had been reflected from a crystal of rock-salt in order to separate out the molybdenum  $K\alpha$  line. The conditions were thus those assumed in deriving equation (5.23). The ratio  $P_s/P$  was measured by opening the slit until all the rays diffracted near an angle  $\theta$  were received into the ionization chamber. The measurement then consisted in observing the ratio of the power received by the chamber at  $2\theta$  to that received by the chamber at the angle zero.

For the first order spectrum from the 100 planes of the powdered rock-salt crystals, the ratio  $P_s/P$  was found in a typical case to be  $3.01 \times 10^{-4}$ , and for the second order,  $0.324 \times 10^{-4}$ . When these values of  $P_s/P$  are introduced into equation (5.23) they give as the corresponding values of  $Q$ ,  $.0232 \text{ cm.}^{-1}$  and  $.0045 \text{ cm.}^{-1}$  respectively. On substituting in equation (5.16), the corresponding values of the structure factor  $F$

<sup>1</sup> J. A. Bearden, Phys. Rev. 27, 796 1926. This measurement is much more precise than an earlier one by Freeman and the author, Nature, 110, 38 (1922).

are found to be (for the molecule of NaCl) 20.4 for the first order and 13.2 for the second order reflection. This means that in the first order the power in the diffracted beam is what it should be if there were 20.4 electrons at the centers of the sodium and chlorine atoms. Since the sum of the atomic numbers is 28, and since the contribution of each electron to the amplitude of the diffracted beam is necessarily somewhat less than if it were at the center of the atom, this result is in good accord with the predictions of the theory.

### 58. *Measurements on Single Crystals*

A greater number of experiments have been performed on the reflection of X-rays by single crystals of rock-salt. If such a crystal were perfect it is clear that we could not apply to it the theory based upon the assumption that the extinction due to reflection is negligible. But it is found by trial that the reflection from a rock-salt crystal is spread over an angle of about half a degree, and within this range of angles reflects only a small fraction (about 5 per cent) of the incident energy in the first order from the (100) planes.

The absolute reflecting power must be measured using mono-chromatic X-rays incident upon the crystals. Otherwise, when the chamber is turned to receive the direct rays, not all of the rays which enter are of the wave-length which is reflected. A suitable arrangement for measuring the absolute reflecting power is that shown in Fig. 67. The measurement may be made by observing the total ionization as the chamber and crystal are moved at a uniform angular velocity  $\omega$  past the spectrum line, and this is compared with the ionization per second at zero angle when the crystal is removed. Thus we obtain the integrated reflection  $W\omega/P$ , which is given theoretically by formulas (5.18) and (5.20).

By this method the author,<sup>1</sup> using a wave-length of .710A, has found the value of  $W\omega/P$  for the first order reflection from a cleavage face of rock-salt to be  $4.0 \times 10^{-4}$ , and W. L. Bragg

<sup>1</sup> A. H. Compton, Phys. Rev. 10, 95 (1917).

and his collaborators<sup>1</sup> have found  $5.5 \times 10^{-4}$  for  $\lambda = .613\text{\AA}$ . These values correspond to values of the structure factor,  $(F_{\text{Cl}} + F_{\text{Na}})$  equal to 16.0 and 16.5 respectively, if calculated using the ordinary values of the absorption coefficient. The fact that these values are appreciably less than the value  $F = 20.4$  found by the powder method indicates that the conditions of the experiments with the solid crystals are not exactly those assumed in developing the theory.

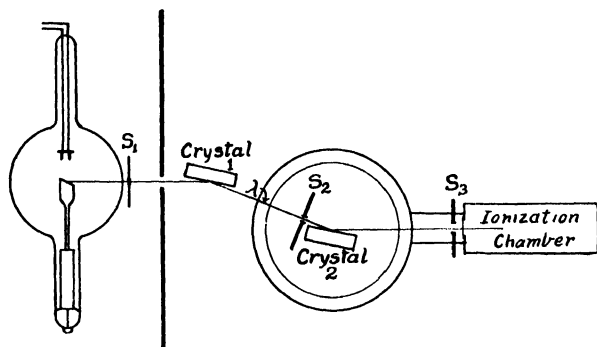

FIG. 67.

When a similar experiment is tried using a crystal of calcite,<sup>2</sup>  $W_{\omega}/P$  is found in a typical case to be  $8.7 \times 10^{-5}$  for  $\lambda = 0.71\text{\AA}$ , which, using the usual absorption coefficient  $23.5 \text{ cm.}^{-1}$ , corresponds to a value of the structure factor per molecule of about 11. This is so much smaller than the sum 50 of the atomic numbers in the  $\text{CaCO}_3$  molecule that one becomes very doubtful of the applicability of the formulas we have developed.

### 59. *Effects of Extinction*

That this doubt is justified may be shown in at least three different ways. 1. Experiments by Davis and Stempel<sup>3</sup> have shown that at the angle of maximum reflection from a cleavage face of calcite almost half of the incident X-rays may be re-

<sup>1</sup> W. L. Bragg, James and Bosanquet, *Phil. Mag.* **41**, 309 (1921), **42**, 1 (1921).

<sup>2</sup> A. H. Compton, *loc. cit.*

<sup>3</sup> B. Davis and W. M. Stempel, *Phys. Rev.* **17**, 608 (1921).

flected. It is obvious that this cannot occur without extinguishing the beam entering the crystal more rapidly than would be the case if the usual absorption alone were effective. 2. That such an additional extinction does occur in some cases has been shown by W. H. Bragg<sup>1</sup> by studying the intensity of the X-rays transmitted by a thin diamond crystal as it is rotated through an angle at which strong reflection occurs. He finds that when the crystal is at the angle for maximum reflection, the intensity of the transmitted beam is considerably less than for other angles. And 3, the fact that the reflecting power of a crystal depends upon its degree of perfection is obvious from the fact that a freshly cleaved crystal surface does not give as great integrated reflection  $W\omega/P$  as does the same surface when ground.<sup>2</sup> The obvious interpretation of this fact is that during the process of grinding the portion of the crystal near the surface is broken into small parts which may be oriented at slightly different angles and which may be slightly offset, destroying the regular phase relations that hold for a perfect crystal. The effect of introducing these faults into the crystal is to reduce the extinction of the rays as they enter, so that a larger volume of the crystal is effective in reflecting the X-rays. Thus the poorer crystal gives the greater integrated reflection.

### 60. *Determination of the Extinction Coefficient*

Though these extinction effects are much more prominent in the case of calcite than for rock-salt, it is obvious that they must occur also to some extent with the latter crystal. In order to determine the importance of this effect in the case of rock-salt, W. L. Bragg, James and Bosanquet have measured the integrated reflection by the transmission method (Fig. 64) of rock-salt crystals of different thicknesses. It will be seen from

<sup>1</sup> W. H. Bragg, *Phil. Mag.* **27**, 881 (1914).

<sup>2</sup> *E.g.*, A. H. Compton, *loc. cit.*, and Bragg and Bragg, *X-Rays and Crystal Structure* (1924), p. 219, who record a *rock-salt* crystal whose cleavage surface reflected only 12.9 per cent as much as did a ground surface.

the discussion on page 7 that if the length of the path of the X-rays in the crystal is  $t$ ,

$$\frac{W_{\omega}}{P_t} = Qte^{-\mu t}, \quad (5.25)$$

where  $P_t = AI$  is the power of the rays incident upon the crystal. An alternative form of this expression is

$$\log \frac{W_{\omega}}{P_t} = \log Q - \mu t. \quad (5.26)$$

Thus if  $\log \frac{W_{\omega}}{P_t}$  is plotted as a function of  $t$ , we should get straight lines whose slope is  $-\mu$  and which intersect the axis  $t = 0$  at  $\log Q$ .

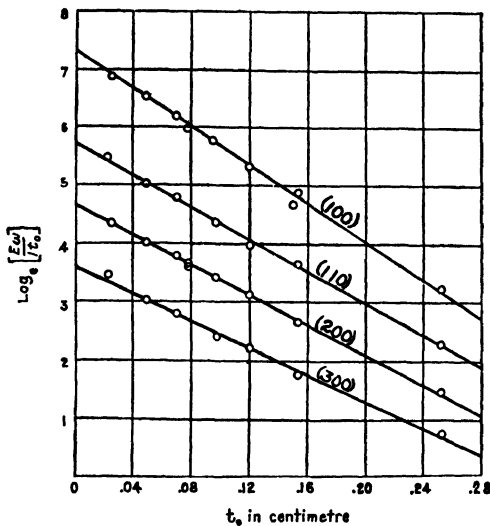

FIG. 68.

In Fig. 68 is shown such a graph, with points representing reflections by crystals varying in thickness from .25 mm. to 2.5 mm. The curves represent data for the first, second and third order reflections from the (100) planes (100, 200 and 300), and the first order from the (110) plane. As will be seen from Table V-1, the slope of the (100) curve represents an absorption

coefficient of 16.30, whereas the normal absorption coefficient of these rays ( $\lambda = .613\text{A}$ ) in rock-salt is 10.70.

TABLE V-1  
REFLECTION AND ABSORPTION OF X-RAYS BY ROCK-SALT  
(Bragg, James and Bosanquet)

Reflection	Effective Absorption Coefficient $\mu$	Extinction Coefficient $\epsilon = \mu - \mu_0$	Reflecting Power $W\omega/Pt$ Arbitrary Units
(100)	16.30	5.60	100
(110)	13.60	2.90	50.5
(200)	12.66	1.96	19.90
(300)	10.72	.02	4.87

Normal absorption coefficient, 10.70.

Thus the value of the extinction coefficient is 5.60. For reflections of higher index than (300), these measurements indicate that the extinction is negligible. For the lower order reflections, it would seem that the formulas we have developed above can be applied if instead of the usual absorption coefficient we use instead the effective absorption coefficient, which includes the extinction coefficient.

### 61. *Experimental Values of the Structure Factor*

Using this effective absorption coefficient in equation (5.20), and solving for the structure factor by equation (5.16) we find, corresponding to Bragg's value of  $W\omega/P = 5.5 \times 10^{-4}$ ,  $F_{\text{Na}} + F_{\text{Cl}} = 20.4$ . Similarly, for the (200) reflection (second order from 100 planes), Bragg finds,  $W\omega/P = 1.09 \times 10^{-4}$  and  $\mu_{\text{eff.}} = 12.66$ , whence  $F_{\text{Na}} + F_{\text{Cl}} = 11.4$ . The close agreement between these values of  $F$  and the values 20.4 and 13.2 for the (100) and the (200) reflections using the powder method, shows the effectiveness of this method of correcting for the extinction.

In the case of rock-salt, we have seen in the last chapter that when X-rays are reflected from the (100) and the (110) planes or from the even orders of the (111) planes, the sodium and

chlorine atoms co-operate in their scattering, that is, the amplitude due to a molecule of NaCl is the *sum* of the amplitudes due to the individual atoms. For odd order reflection from planes such as (III), where there are alternate layers of sodium and chlorine atoms, however, the amplitude due to a molecule of

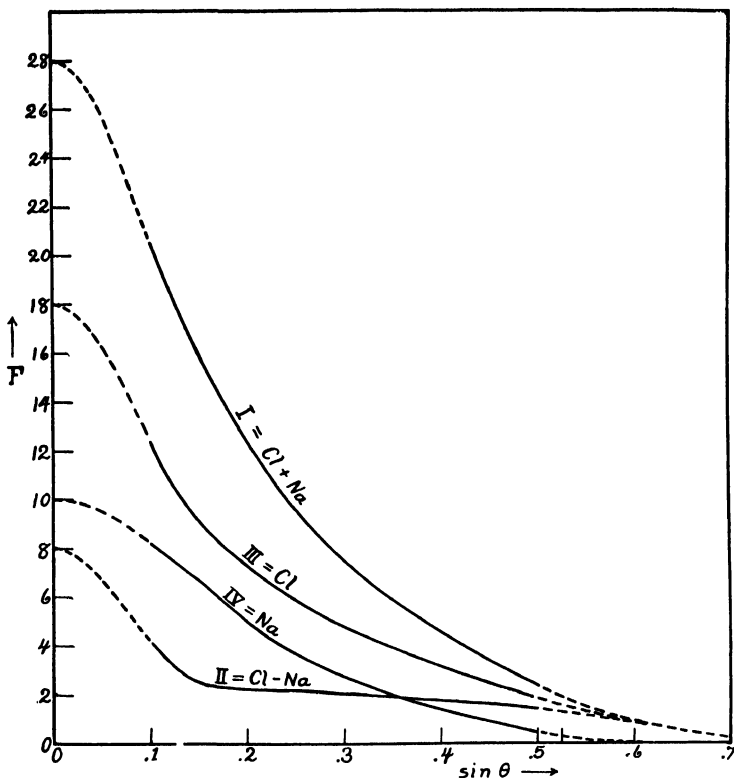

FIG. 69.

NaCl is the difference between the amplitudes due to the chlorine and sodium atoms. When we calculate the structure factor per NaCl molecule we thus get in the former case  $F_{Na} + F_{Cl}$  and in the latter case  $F_{Cl} - F_{Na}$ . These values of  $F$ , as based on the data of Bragg, James and Bosanquet are shown as curves I and II in Fig. 69, plotted as functions of  $\sin \theta$ .

The fact that the various values of  $F$  as thus determined lie

on smooth curves, even though they are based on measurements of reflections from planes with many different orientations, indicates that the sodium and chlorine atoms have practically spherical symmetry. This isotropic character of the atoms enables us to estimate the structure factor of the individual atoms at each angle. For taking at any particular angle the appropriate values of  $F_{\text{Cl}} + F_{\text{Na}}$  and of  $F_{\text{Cl}} - F_{\text{Na}}$  from the curves I and II, we have at once,

$$F_{\text{Cl}} = \frac{1}{2} \{ (F_{\text{Cl}} + F_{\text{Na}}) + (F_{\text{Cl}} - F_{\text{Na}}) \}$$

and

$$F_{\text{Na}} = \frac{1}{2} \{ (F_{\text{Cl}} + F_{\text{Na}}) - (F_{\text{Cl}} - F_{\text{Na}}) \}.$$

The structure factors thus calculated for the individual atoms are given in curves III and IV.

#### 4. REFLECTION BY PERFECT CRYSTALS, AND THE EFFECT OF EXTINCTION

##### 62. *Difference between Reflection from Perfect and Imperfect Crystals*

Before we undertake to determine the electronic arrangement corresponding to the structure factors determined in the manner just described, let us consider the problem of X-ray reflection on the assumption that the crystals which we use are approximately perfect. In this case the extinction of the rays due to reflection from the surface layers is of much more importance than the ordinary absorption. It may be noted that since the rays reflected from successive layers of atoms are in phase with each other, the "wave of reorganization," proceeding from the upper layers in the direction of the incident beam and exactly opposite in phase, is much more effective in extinguishing the incident rays than we should suppose if we were to consider separately the energy reflected from each layer in turn. The result is that for a perfect crystal, the depth in the crystal that is effective in scattering the X-rays is very small indeed.

That this must be the case was made obvious by Darwin,<sup>1</sup>

<sup>1</sup>C. G. Darwin, *Phil. Mag.* 27, 255 (1894).

when he showed that a calculation such as we have carried out above, if applied to a perfect crystal, predicts near the angle of maximum reflection a reflection of many times as much energy as is incident upon the crystal. The principle of the conservation of energy thus demands that the thickness of the layer effective in reflection shall be much smaller than if it were determined by the ordinary absorption of the X-rays in the crystal.

### 63. Theory of Reflection from a Perfect Crystal

If near the angle of maximum reflection we neglect the normal absorption in comparison with the extinction, Darwin<sup>1</sup> and independently though much later Ewald<sup>2</sup> have shown that a perfect crystal should reflect all of the rays incident upon it within a certain range of glancing angles, as is illustrated in Fig. 70. If the incident rays are polarized in the plane of re-

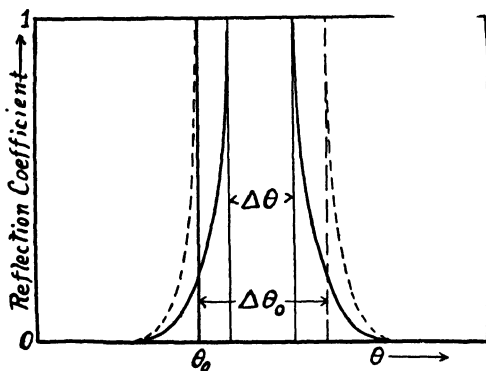

FIG. 70.

flection, and if the electrons were all in the midplanes of their atomic layers ( $F = Z$ ), the region of complete reflection should

<sup>1</sup> C. G. Darwin, *Phil. Mag.* **27**, 675 (1914).

<sup>2</sup> P. P. Ewald, *Phys. Zeits.* **26**, 29 (1925). When Ewald alludes to the naïve theories of the earlier investigators he is apparently unaware that the theory he develops had been worked out more completely eleven years before by Darwin, who recognized its inadequacy.

<sup>3</sup> The shift of the angle of maximum reflection from  $\theta_0$  to  $\theta_0 + \frac{1}{2}\Delta\theta_0$  may be considered as an effect of refraction. It is identical with the departure from Bragg's law discussed in Chapter VII.

extend from  $\theta_0$  (defined by  $n\lambda = 2D \sin \theta_0$ ) to  $\theta_0 + \Delta\theta_0$ .<sup>3</sup> The range of angles for complete reflection in this case is

$$\Delta\theta_0 = \frac{2nZ}{\pi} \frac{e^2}{m} \frac{1}{\nu^2 - \nu_0^2} \frac{1}{\sin 2\theta} \quad (5.27)$$

Here  $n$  is the number of atoms per unit volume,  $\nu$  is the frequency of the X-rays and  $\nu_0$  the natural frequency of the electrons. Since the crystals usually used are composed only of light atoms, it is evident from our discussion of the scattering of X-rays that  $\nu_0^2$  is very small compared with  $\nu^2$  for all the electrons which contribute to the scattering. This may therefore be written, since  $\nu = c/\lambda$ ,

$$\Delta\theta_0 = \frac{2nZe^2\lambda^2}{\pi mc^2} \frac{1}{\sin 2\theta} \quad (5.28)$$

In addition to the energy in the region  $\Delta\theta_0$  where the reflection is complete, there is also appreciable reflection in the neighboring region where the intensity is falling gradually to zero. Darwin shows that when the reflection in the latter region is included the effect is the same as if there were complete reflection over an angular range of  $\frac{4}{3} \Delta\theta_0$ .

When the structure factor is less than  $Z$ , and when the incident rays are unpolarized, the center of the reflected line remains in the same position, but the region over which complete reflection occurs is not so broad. When the electric vector is perpendicular to the plane of reflection, the range of complete reflection is  $\Delta\theta_0 F/Z$ , whereas when the electric vector is in the plane of reflection the range is  $\Delta\theta_0 F \cos(2\theta)/Z$ . Thus for the effective range of complete reflection for unpolarized rays

$$\begin{aligned} \Delta\theta &= \frac{8}{3\pi} nF\lambda^2 \frac{e^2}{mc^2} \frac{1 + \cos 2\theta}{2 \sin 2\theta} \\ &= \frac{4}{3\pi} nF\lambda^2 \frac{e^2}{mc^2} \cot \theta. \end{aligned} \quad (5.28a)$$

The reflection of such unpolarized rays by a perfect crystal is represented in Fig. 70 by the solid line.

If the crystal is turned with angular velocity  $\omega$  past the region of reflection of the wave-length  $\lambda$ , the rays will be incident between  $\theta$  and  $\theta + \Delta\theta$  for a time  $\Delta\theta/\omega$ . Since in effect the reflection over this range is complete, the energy reflected during this interval is

$$W = P\Delta\theta/\omega,$$

where  $P$  is the power of the beam striking the crystal. Thus

$$\frac{W\omega}{P} = \Delta\theta = \frac{4}{3\pi} nF\lambda^2 \frac{e^2}{mc^2} \cot\theta. \quad (5.29)$$

#### 64. Comparison with Experiment

In the case of calcite, we have seen (p. 134) that the value of  $W\omega/P$  for a certain cleavage face, was  $8.7 \times 10^{-5}$  for  $\lambda = 0.71\text{\AA}$ . If in equation (5.29) we place  $F = Z$ , that is, if all the electrons were at the middle of the diffracting layers, an assumption which gives the maximum possible reflection on this theory, we find  $W\omega/P = 4.1 \times 10^{-5}$ , less than half of the experimental value. The fact that the theoretical and the experimental values are of the same order of magnitude may be taken to indicate that calcite approaches the characteristics of a perfect crystal. But the fact that the observed reflection is definitely greater than is thus calculated can only mean that calcite does not actually attain this standard.

Other experiments in this connection which may be compared with Darwin's theory for a perfect crystal are those of Davis and Stempel,<sup>1</sup> in which they have measured the fraction of the X-rays reflected from a crystal when the rays strike at a definite angle near that for maximum reflection. Their apparatus is similar to that shown in Fig. 67. The first crystal, calcite in their experiments, served to collimate the rays, so that if the face of the second crystal was parallel to the first the rays struck the second at the angle for maximum reflection. The best reflection from the second crystal was obtained when a good calcite crystal was cleaved and the two halves were used for the

<sup>1</sup> B. Davis and W. M. Stempel, *Phys. Rev.* **17**, 608 (1921).

collimating and reflecting crystals. Under these conditions they observed a maximum reflection coefficient as great as 44 per cent with the second crystal at the best angle. This is to be compared with the 100 per cent, or complete reflection predicted by the theory. The angular breadth of the reflected band, measuring to where the intensity is reduced to half of its maximum value, is in Davis and Stempel's experiments 18 seconds of arc when  $\lambda = .68\text{\AA}$ , which may be compared with Darwin's prediction that  $\Delta\theta_0 = 5.8$  seconds, though there is no reason to suppose that the two angles should be exactly the same. We may draw the conclusion from these experiments also that, although a crystal of calcite may approach perfection, it is yet too far from perfect for us to apply to its reflection the theory for a perfect crystal.

Since calcite is one of the most nearly perfect crystals which we have to study, there thus seems little hope of being able to apply the theory for a perfect crystal strictly to any real crystal. On the other hand, we have seen that the theory for an irregular crystal is not strictly applicable even to a crystal as imperfect as rock-salt—much less to calcite. For real crystals, therefore, we may expect to find reflection occurring in a manner which is intermediate between that described by equation (5.20) and that described by (5.29).

### 65. *Effect of Extinction in Real Crystals*

It is clear from this discussion that it is hopeless to try to find a crystal so nearly perfect that we can apply to it with confidence the formulas for reflection from a perfect crystal. If we are to succeed in our efforts toward determining the distribution of the electrons, we must therefore look for irregular crystals, to which we can apply the other set of formulas. But what degree of imperfection must a crystal have in order that we may consider it irregular? This question has recently been examined in detail by Darwin.<sup>1</sup> He distinguishes two types of extinction, "primary" extinction, which occurs within each

<sup>1</sup> C. G. Darwin, *Phil. Mag.* 43, 800 (1922).

little block that acts like a perfect crystal, and secondary extinction, which represents the shielding of the blocks deep in the crystal by the reflection of the X-rays from the blocks near the surface. If both types of extinction can be made negligible the crystal mass may be classed as what we have called an irregular crystal.

Regarding the primary extinction, at the angle of maximum reflection from the (100) face of a perfect rock-salt crystal, under the conditions of Bragg, James and Bosanquet's experiments, this is about 140 times as effective as the ordinary absorption coefficient. If the crystal has a thickness of  $m$  layers of atoms, Darwin finds that the correction to the reflecting power  $W_\omega/P$  due to the primary extinction can be made to a close approximation by multiplying the values given by equations (5.16), (5.18) and (5.20) by the factor

$$\frac{\tanh mq}{mq}, \quad (5.30)$$

where 
$$q = nFD\lambda \frac{e^2}{mc^2} \csc \theta, \quad (5.31)$$

$D$  being the distance between the atomic layers, and  $n$  the number of atoms per unit volume. In applying this correction, however, the difficulty arises that there is no satisfactory method for determining  $m$ , the number of atomic layers in each effectively perfect block.<sup>1</sup>

Estimates of the extinction coefficient by determining the effective absorption of the X-rays in the crystal, as Bragg and his collaborators have done for rock-salt, give only the secondary extinction coefficient. The primary extinction in each little perfect block of the crystal struck by X-rays at just the right angle might be almost complete, yet the average extinction co-

<sup>1</sup> Darwin discusses a possible method of finding this correction by a study of the form of the reflection curve for different angles of incidence ( $\theta + \alpha$ ). He considers it doubtful, however, whether application of the method to a real crystal is practicable.

efficient might be low because only a few of the blocks were properly oriented. The maximum value of the primary extinction coefficient is according to Darwin  $\epsilon_{\max.} = 2nF\lambda e^2/mc^2$ . Since  $F$  decreases with increasing  $\theta$ , the extinction is most important for small angles or low orders of reflection. For the (100) reflection of  $\lambda .683\text{\AA}$  from rock-salt,  $\epsilon_{\max.} = 1500$ . That is, if we wish to limit the primary extinction to 1 per cent, the linear dimensions of each perfect block must be less than  $.01/1500 = 7 \times 10^{-6}$  cm., or only about 250 atomic layers. Thus in order to be *certain* that the results are unaffected by primary extinction, we should have to pulverize the crystals until the individual pieces are barely visible with the high power microscope.

It is probable, however, that in many cases the primary extinction is negligible even for crystals of large size. For on a visible scale we find that rock-salt crystals have their surfaces twisted and bent, and if this is also true on a microscopic scale the phase differences between successive atomic layers must be irregular except for very small thickness of the crystal. Moreover, since we have seen that grinding and polishing makes a crystal face less perfect for an appreciable depth below the surface, it is probable that if a crystal is ground into units of a given size the parts of each unit that are sensibly perfect are much smaller than the units themselves.

The problem of the secondary extinction is not so difficult. Even this, however, is not quite as simple as we have supposed when we have attempted to correct for the mutual effect of the different layers by adding an "extinction coefficient" to the normal absorption coefficient. In making this correction we take into account the reduction in intensity at the lower layers due to reflection of part of the X-rays by the upper layers. But we neglect the additional effect on the upper layers of the partial reflection of the X-rays by the lower layers. Even in the case of rock-salt under the conditions of Bragg's experiments about 5 per cent of the X-ray intensity at the crystal surface when oriented near the angle  $\theta$  is due to rays reflected from within the crystal. The effect of this is to make the reflected beam slightly

more intense that it would be if the extinction alone were considered.<sup>1</sup>

It can be shown that this tertiary radiation effect is more important for thick crystals than for thin ones. Experimental curves such as those shown in Fig. 68 should for this reason tend to be slightly concave upwards. The fact that they are sensibly straight may be taken to indicate that in the case of rock-salt the tertiary reflection is not important. Even had the experimental curve been concave, it is clear that the intersection of the curve with the axis  $t = 0$  would give  $\log Q$ . Thus the slope of a straight line drawn from this intersection to meet the experimental curve at about  $t = 1/\mu$  would give an effective absorption coefficient that would enable us to calculate  $Q$  very closely from the observed value of  $W\omega/P$ . The method used by Bragg for estimating the effect of the secondary extinction thus seems to be adequate.

#### 66. *Criteria for Detecting Primary Extinction*

There are at least three ways of testing whether it is permissible to neglect the effect of primary extinction in a set of experiments such as those of Bragg, James and Bosanquet.

1. If two samples of the crystal which differ widely in the perfection of their structure give the same value of  $Q$ , presumably the primary extinction is unimportant.
2. A test of the same kind might be made comparing the value of  $Q$  obtained using a large conglomerate crystal with that obtained using finely pulverized crystals.
3. We have seen that if primary extinction is the important factor in determining the penetration into the crystal, the reflecting power  $W\omega/P$  should be proportional to  $F$ , whereas if the primary extinction is negligible  $W\omega/P$  should be proportional to  $F^2$ . In a crystalline compound such as NaCl, where by comparing the reflections from different planes it is possible to distinguish the reflections from the different atoms, we can tell to which factor the reflection is proportional.

<sup>1</sup> Darwin gives a somewhat detailed discussion of this matter in his 1922 paper. It is also considered mathematically from certain aspects by K. W. Lamson, *Phys. Rev.* **27**, 624 (1921).

Bragg, James and Bosanquet found about the same values of  $Q$  for a considerable number of different crystals which were sufficiently imperfect, thus satisfying the first test.

We have seen that the value of  $Q$  measured by Bearden for powdered crystals is identical with that of Bragg, James and Bosanquet for the (100) reflection. Both Havighurst<sup>1</sup> and Bearden have failed to find any difference in the intensity of the reflection from powdered NaCl crystals according to the fineness of grinding. This indicates that no effect of primary extinction is present with the powdered crystals. Thus it seems also that Bragg and his collaborators have succeeded in correcting for the extinction with the solid crystals of rock-salt.

For the (200) and (300) reflections Bearden's values of  $F'$  obtained from powdered crystals are larger than those of Bragg, by an amount that seems to be greater than the experimental error. This would indicate that for these reflections the correction made for the extinction coefficient with the single crystals is somewhat too small. Havighurst, also using powdered crystals, has however obtained results agreeing with those of Bragg.

The third test supplies the answer to a riddle which has long been a source of confusion. In the case of rock-salt we have seen that in separating the effects of the sodium and chlorine atoms we get consistent results if we assume that the amplitude is proportional to  $F$  and the intensity  $F^2$ . This satisfies our test for the absence of primary extinction. But in order to interpret the spectra obtained from calcite, W. H. Bragg<sup>2</sup> has shown that one must assume that the intensity rather than the amplitude of the reflected ray is proportional to the atomic number. Bragg wrote me in 1916 that some of his results point one way and some the other. We now see that it is the degree of perfection of the crystal which determines whether the intensity is more nearly proportional to  $F$  or to  $F^2$ .<sup>3</sup>

<sup>1</sup> R. J. Havighurst, *Phys. Rev.* (1926).

<sup>2</sup> W. H. Bragg, *Phil. Trans. Roy. Soc. A.*, 215, 253 (1915).

<sup>3</sup> A paper by B. W. James has recently appeared (*Proc. Roy. Soc. A.* 109, 614, 1925) in which this criterion for distinguishing between perfect and imperfect crystals is developed in detail. See also W. L. Bragg, *Phil. Mag.* 50, 306 (1925).

We may thus rest assured that in these experiments on rock-salt the primary extinction is of little if any importance, while the method of allowing for secondary extinction seems to be adequate. The values of the structure factor  $F$  calculated from these measurements can thus be used tentatively as the basis for calculating the distribution of the electrons within the atoms.

#### 5. THE DETERMINATION OF ELECTRONIC DISTRIBUTIONS FROM A KNOWLEDGE OF THE STRUCTURE FACTOR

##### 67. *Three Methods of Calculating the Electron Distribution*<sup>†</sup>

We are now prepared to undertake the interesting and important problem of finding what arrangement of electrons will account for the experimental values of  $F$ . Three methods of attacking this problem have been used. These are a method of trial, the use of an empirical reflection formula, and an application of Fourier's series.

##### 68. *Method of Trial*

In the method of trial,<sup>2</sup> one assumes various arbitrary values of  $p(z)$  in the expression for the structure factor,

$$F = Z \int_{-D/2}^{D/2} p(z) \cos \left( 4\pi \frac{z}{\lambda} \sin \theta \right) dz. \quad (5.07)$$

It can readily be shown that if there is a group of electrons arranged at random on the surface of a spherical shell of radius  $r$ , then for each of these electrons

$$p(z) = 1/2r, \quad (5.34)$$

between the limits  $-r$  and  $r$ . The value of  $F$  for a shell of  $m$  electrons is thus

$$m \int_{-r}^r \frac{1}{2r} \cos \left( 4\pi \frac{z}{\lambda} \sin \theta \right) dz = m \frac{\sin \left( 4\pi \frac{r}{\lambda} \sin \theta \right)}{4\pi \frac{r}{\lambda} \sin \theta}. \quad (5.35)$$

<sup>†</sup> A. H. Compton, *Phys. Rev.* **9**, 49 (1917).

Thus for an atom composed of a number  $p$  of such electronic shells the structure factor is

$$F = \sum_1^p m_s \sin \left( 4\pi \frac{r_s}{\lambda} \sin \theta \right) / \left( 4\pi \frac{r_s}{\lambda} \sin \theta \right). \quad (5.36)$$

When this method is applied with care, it gives results which are perhaps as reliable as those obtained by the more direct method of Fourier series.

Bragg, James and Bosanquet have used this method in analyzing their data for the intensity of reflection by rock-salt. From an exhaustive study of the various possibilities, they find the best agreement with the experimental values<sup>1</sup> of  $F$  when the distribution of electrons on shells is as follows:

Sodium,	7 electrons on a shell of radius 0.29Å
	3 electrons on a shell of radius 0.76Å
Chlorine,	10 electrons on a shell of radius 0.25Å
	5 electrons on a shell of radius 0.86Å
	3 electrons on a shell of radius 1.76Å

Bragg and his collaborators have found, however, using a method similar to that described in section 70, that a better agreement with the experimental data can be obtained assuming a continuous distribution of the electrons. The most satisfactory agreement with the experimental data was obtained with the electron distribution shown in Figs. 71 and 72.

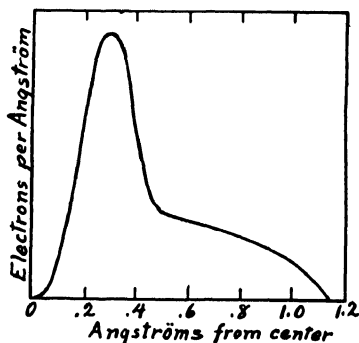

FIG. 71.

### 69. Use of Empirical Reflection Formula

The second method of solution consists in finding an empirical formula, such as expression (5.01), which represents the

<sup>1</sup> In the work of Bragg, James and Bosanquet the factor  $F$  was corrected for the effect of the thermal agitation.

experimental data, and equating this expression to the appropriate formula which gives the theoretical intensity in terms of the structure factor. Thus we may place expressions (5.01) and (5.20) equal to each other, obtaining

$$F^2 = \frac{8\mu}{n^2\lambda^3} \frac{m^2c^4}{e^4} C e^{-B \sin^2 \theta} \cot \theta. \quad (5.37)$$

The factor  $e^{-B \sin^2 \theta}$  was introduced into the empirical formula from theoretical considerations to take account of the thermal agitation of the molecules (cf. *infra*, p. 159). Dropping this

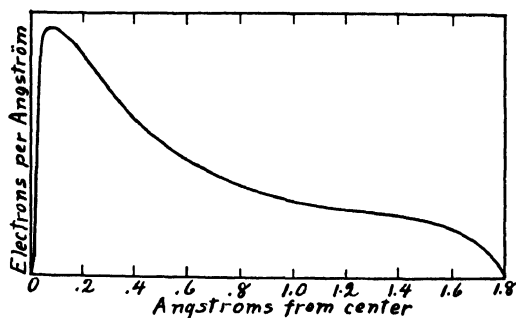

FIG. 72.

factor is merely equivalent to correcting  $F^2$  for the temperature agitation. In any case it differs only slightly from unity. If we make the further approximation that  $\cot \theta = \csc \theta$ , since in the experiments  $\theta$  is never large, we may write from (5.37),

$$\frac{F}{z} = \int p(z) \cos \left( 4\pi \frac{z}{\lambda} \sin \theta \right) dz = K \csc^{1/2} \theta. \quad (5.38)$$

The only solution of this integral equation which satisfies the physical conditions is <sup>1</sup>

$$p(z) = bz^{-1/2}. \quad (5.39)$$

This corresponds to a distribution of electrons about each atom for which the number of electrons in a spherical shell between a distance  $r$  and  $r + dr$  from the center of the atom is proportional to  $1/r^{1/2}$ .

<sup>1</sup> A. H. Compton, loc. cit.

Such a solution is of little value, since it implies an atom with an infinite radius. It is interesting to note, however, that the greater part of Bragg's curve for chlorine is represented by a curve very similar to the graph of  $1/r^{1/2}$  (Fig. 72).

### 70. *Method of Fourier Series*

By far the most satisfactory method of determining the electron distribution from the observed values of  $F$  is by an application of a form of Fourier analysis. This method was used first by W. H. Bragg,<sup>1</sup> though in a manner unsuited to give accurate results. It has recently been put in a very usable form by Duane,<sup>2</sup> and has been applied with valuable results by Havighurst.<sup>3</sup>

Let us first write the expression for the structure factor in a slightly different form. In most of this chapter we have assumed that we are dealing with a crystal made of similar atoms arranged on a simple cubic lattice. We can, if we wish, refer any cubic crystal to a simple cubic lattice of points all of which are identical. Thus for rock-salt, the lattice constant would be  $a = 2D_{100}$ , where  $D_{100}$  is the distance between successive layers of atoms in the 100 planes, and there would thus be 4 Na atoms and 4 Cl atoms associated with each point in the lattice.  $F$  may now be used to represent the structure factor for this lattice unit. Considering for the present only reflections from the (100) planes we then have

$$F = Z \int_{-a/2}^{a/2} p(z) \cos \left( 4\pi \frac{z}{\lambda} \sin \theta \right) dz,$$

where  $Z$  is now the total number of electrons in the lattice unit. Since  $n\lambda = 2a \sin \theta$ , where  $n$  is the order considering the grating

<sup>1</sup> W. H. Bragg, *Phil. Trans. Roy. Soc.* 215, 253 (1915).

<sup>2</sup> W. Duane, *Proc. Nat. Acad. Sci.* 11, 489 (1925). Duane's method of treating the problem is entirely different from that used here, being based on a quantum theory of diffraction. He arrives, however, at identically the same result as eq. 5.48.

<sup>3</sup> R. J. Havighurst, *Proc. Nat. Acad. Sci.* 11, 502 (1925).

space to be  $a$ ,  $4\pi\frac{z}{\lambda}\sin\theta = 2\pi n\frac{z}{a}$ , whence,

$$F_n = Z \int_{-a/2}^{a/2} p(z) \cos\left(2\pi n\frac{z}{a}\right) dz \quad (5.40)$$

is the value of the structure factor for the  $n$ th order.

### 71. *Electron Density at Any Height Above the Middle of an Atomic Layer*

Let us now express the number of electrons per unit height,  $Zp(z)$ , as a Fourier cosine series, thus: †

$$\begin{aligned} P \equiv Zp(z) &= A_0 + A_1 \cos 2\pi\frac{z}{a} + A_2 \cos 4\pi\frac{z}{a} + \dots \\ &+ A_n \cos 2\pi n\frac{z}{a} + \dots \\ &= \sum_0^{\infty} A_r \cos\left(2\pi r\frac{z}{a}\right). \end{aligned} \quad (5.41)$$

The structure factor then becomes:

$$F_n = \int_{-a/2}^{a/2} \sum_0^{\infty} A_r \cos\left(2\pi r\frac{z}{a}\right) \cos\left(2\pi n\frac{z}{a}\right) dz.$$

On integration it is found that every term vanishes except that for which  $r = n$ , so that

$$\begin{aligned} F_n &= \int_{-a/2}^{a/2} A_n \cos^2\left(2\pi n\frac{z}{a}\right) dz \\ &= \frac{1}{2}aA_n. \end{aligned}$$

Thus

$$A_n = \frac{2}{a}F_n. \quad (5.42)$$

The experimental determinations of  $F_n$  carry with them therefore determinations of the coefficients of the terms in the Fourier expression (5-41) for the density of distribution of electrons.

It is clear that the same procedure may be followed for planes of any index. The results are especially instructive in the case of (111) planes, since in this case for rock-salt we deal with alternate layers of sodium and chlorine atoms. The only necessary modification of equations (5-41) and (5-42) is to let  $a$  represent the distance between the (111) planes of the space lattice.

An illustration of a calculation of this type is given in Fig. 73. Here the light lines represent the individual terms

$$\frac{2}{a} F_n \cos 2\pi n \frac{z}{a},$$

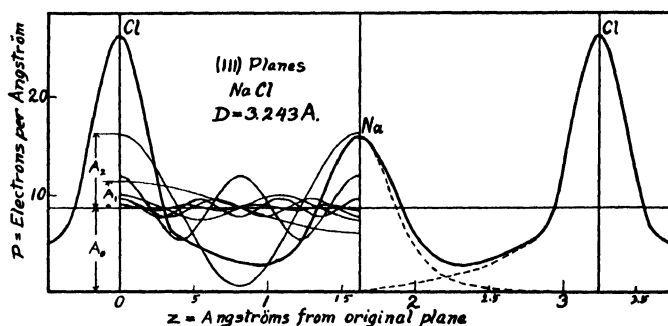

FIG. 73.

where  $a_{111} = \frac{2}{\sqrt{3}} \cdot 2.814\text{A} = 3.243\text{A}$ , and the values of  $F_n$  are those of  $F_{111}$ ,  $F_{222}$ , . . . , per NaCl molecule as measured by Bragg, James and Bosanquet, uncorrected for the temperature. The heavy line represents

$$\frac{2}{a} \sum_1^{\infty} F_n \cos 2\pi n \frac{z}{a},$$

and therefore represents the value of  $P$  given by equation (5-41) except for the constant term  $A_0$ .

The value of this constant term can be evaluated from equation (5-41) from the fact that

$$\int_{-a/2}^{a/2} p(z) dz = 1.$$

But by (5-41),

$$\int_{-a/2}^{a/2} p(z) dz = \frac{A_0}{Z} a + \sum_1^{\infty} \int_{-a/2}^{a/2} \cos 2\pi r \frac{z}{a} dz,$$

or

$$1 = \frac{a}{Z} A_0 + 0,$$

whence,<sup>1</sup>

$$A_0 = Z/a. \quad (5.43)$$

The number of electrons in an elementary cube between the heights  $z$  and  $z - dz$  from the middle of an atomic layer can thus be calculated from the expression

$$P_z = \frac{Z}{a} + \frac{2}{a} \sum_1^{\infty} F_n \cos \left( 2\pi n \frac{z}{a} \right), \quad (5.43a)$$

where  $n$  is the order of reflection from planes whose spacing is  $a$ .

In the case under consideration, for a molecule of NaCl  $Z = 28$ , and  $A_0 = 28/3.243 = 8.63$ , if  $z$  is measured in Ångströms. In Fig. 73, this value of  $A_0$  is represented by the height from the heavy base line to the light base line used for constructing the component curves. The density of distribution of the electrons at a distance  $z$  from the mid-plane of a (111) layer of chlorine atoms is thus proportional to the height  $P$  of the heavy curve of this figure.

It will be noticed that midway between the large humps at  $z/D = 0, 1, \dots$ , appear smaller humps. These of course represent the layers of sodium atoms between the layers of chlorine atoms. In this method of analysis the existence of such alternate layers of atoms is not assumed, but follows from the observed values of  $F$  for the different orders. The fact that in between the successive atomic layers the electron density does

<sup>1</sup> If the Fourier series 5-41 is taken from  $r = -\infty$  to  $r = +\infty$  instead of from 0 to  $\infty$ , we have instead of equation 5-42,  $A_n = F_n/a$ . Since for  $n = 0$ ,  $F = Z$ , it follows at once that  $A_0 = Z/a$ , which is equation 5-43. Though this brings out more clearly the relations between  $A$ ,  $F$  and  $Z$ , the series used in the text has the practical advantage of having only half as many terms.

not fall to zero means that the outer parts of the sodium and chlorine atoms overlap each other.

In order from this figure to make an estimate of the relative number of electrons in the alternate atomic layers, it is necessary to try to resolve the heavy curve representing the sum of the electrons in both kinds of atoms into two curves, each representing the electrons in atoms of one kind. Such a resolution is indicated by the broken lines, in which the area under the two curves as measured by a planimeter is in the ratio of 1.80 : 1.00. This is the ratio  $18/10 = 1.8$  to be expected if the valence electron of sodium has been transferred to chlorine. Though a different resolution might be effected, giving the ratio  $17/11 = 1.54$  corresponding to the complete atoms in each layer, we may thus assume provisionally that the atoms are in the form of ions, a conclusion reached by Bragg and his collaborators from these data following a different line of argument.

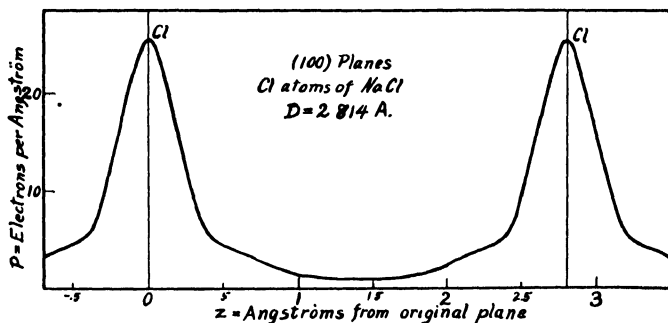

FIG. 74.

In order that the adjacent atomic layers shall not overlap as in Fig. 73, we must consider planes in which successive layers are farther apart. Thus if we calculate in the manner just described the electron distribution for the (100) planes, using the experimental values of  $F_{Cl}$  given in curve III of Fig. 69, we find the values of  $P$  for the chlorine atoms shown in Fig. 74. It will be seen that the planes are even in this case not far enough apart to prevent some overlapping.

This difficulty can however be overcome by calculating the

distribution for planes so far apart that overlapping of the successive layers of atoms is impossible.<sup>1</sup> Thus Figs. 75 and 76 represent the distributions  $P$  in layers of chlorine and sodium atoms respectively calculated for a grating space of  $6.13A$ .<sup>2</sup> Of course planes with such a grating space do not exist in a crystal of rock-salt, but if they were present the appropriate values of  $F$  should be given by the curves of Fig. 5-09. The values of  $F$  that have been used in calculating Figs. 75 and 76 are as follows:

TABLE V-2

Order ( $D = 6.13A$ )	$F_n$ Cl	$F_n$ Na	Order ( $D = 6.13A$ )	$F_n$ Cl	$F_n$ Na	
1	16.31	9.59	9	2.50	.91	
2	12.35	8.20	10	1.86	.44	
3	9.10	6.65	extrap. {	11	1.35	.14
4	7.27	4.99		12	.92	.04
5	5.84	3.64		13	.53	0
6	4.75	2.75		14	.24	
7	3.85	2.00		15	.05	
8	3.16	1.42		16	.006	
.....	.....	.....	$A_0$	2.94	1.63	

The values of  $F$  from order 2 to order 10 are read directly from the experimental portion of curves III and IV of Fig. 69.

<sup>1</sup> The logical extension of this method would be to calculate the distribution for an infinite grating space. In this case the Fourier series (5.41) becomes a Fourier integral,

$$P_x = 2 \int_0^{\infty} F_x \cos(2\pi x z) dx, \quad (5.43a)$$

where  $x = (2 \sin \theta) / \lambda$ , and  $F_x$  is the value of  $F$  taken from curves such as those of Fig. 5.09 but plotted against  $x$  instead of  $\sin \theta$ . The evaluation of this integral for various values of  $z$  can be performed graphically, but the process is laborious. The result is also probably less reliable than that obtained by evaluating a series as is done here, both because of the inaccuracies of graphical integration and because knowledge is assumed of the form of the extrapolated portion of the  $F$  curve, which is not used in the series method.

<sup>2</sup> For this grating constant  $\sin \theta = .05$  for the first order, which enables the values of  $F$  to be read easily from Fig. 69.

It can be shown that the manner in which the values for orders higher than 10 are extrapolated to zero makes little difference in the form of the electron distribution curve. For order 1 the value of  $F$  is so chosen that the area  $\int Pdz$  of the peak repre-

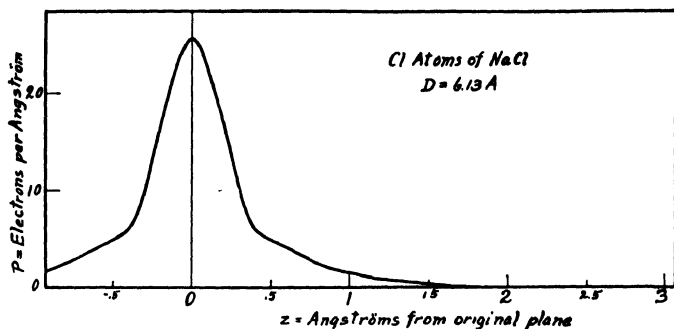

FIG. 75.

senting the chlorine atom is 18 electrons, and that representing the sodium atom is 10 electrons.<sup>1</sup>

The most striking feature of these curves is that the electron density of the atomic layers falls definitely to zero, for chlorine

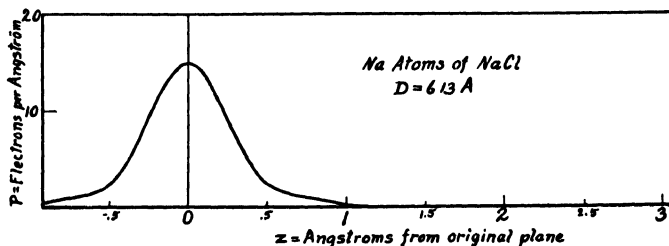

FIG. 76.

at about  $2\text{\AA}$ , and for sodium at about  $1.1\text{\AA}$ . It is highly improbable that the long straight portion between the humps at the atomic centers, representing zero electron density, would occur as a matter of chance. Its existence gives confidence not only in the reliability of the method, but also in the

<sup>1</sup> The appropriate value of  $F_1$  is readily found by the help of equation (5.52).

accuracy of the data used to calculate the different terms in the Fourier series.

Duane<sup>1</sup> has called attention to the fact that from the intensities of the X-ray spectra it is impossible to tell whether

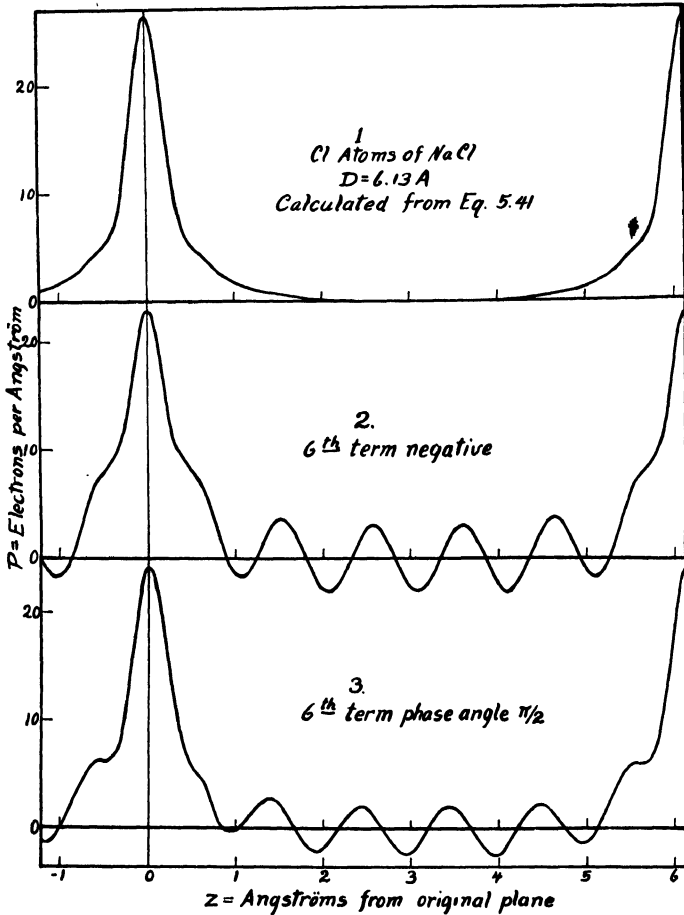

FIG. 77.

the coefficients of the terms in equation (5.41) are positive or negative, and that the only reason for considering the phase angle of each term to be zero is considerations of symmetry. In Fig. 77 are plotted in three different ways the values of  $P$

<sup>1</sup> W. Duane, Proc. Nat. Acad. Sci. 11, 480 (1925).

for chlorine using the data of Table V-1. Curve 1 is that given in Fig. 75 as calculated from equation (5.41). In curve 2, the coefficient of the 6th term has been taken to be negative, the other terms having their former values. For curve 3 the 6th term was  $\frac{2}{a}F_6 \cos\left(2\pi \cdot 6 \frac{z}{a} + \frac{\pi}{2}\right)$ , showing the effect of introducing an arbitrary phase angle. The fact that curves 2 and 3 indicate impossible negative densities of distribution in some places whereas curve 1 does not, confirms the correctness of the assumptions that all the Fourier coefficients are positive and that the phase angles are zero.

### 72. Electron Density at Any Point in the Space Lattice

The method of analysis that has just been discussed gives the number of electrons in a sheet taken parallel to some atomic layer. The electron density at any point,  $x, y, z$  within the lattice can be calculated in the following manner.

Let us consider the reflection from the  $(h, k, l)$  plane in the crystal. Writing  $s$  as the distance along the normal to this plane, we have (equation 5.40)

$$F_{n(h, k, l)} = Z \int_{-D_{hkl}/2}^{D_{hkl}/2} \rho(s) \cos\left(2\pi n \frac{s}{D_{hkl}}\right) ds. \quad (5.44)$$

But by equations (4.05) and (4.06),

$$s = \frac{hx + ky + lz}{\sqrt{h^2 + k^2 + l^2}},$$

and

$$D_{hkl} = a/\sqrt{h^2 + k^2 + l^2}.$$

Thus

$$\cos 2\pi n \frac{s}{D_{hkl}} = \cos 2\pi \frac{n}{a}(hx + ky + lz). \quad (5.45)$$

Let  $dS$  represent an element of area of an  $(h, k, l)$  plane. Then if  $\rho$  is the electron density at any point,  $\rho dS ds$  is the number of electrons in an element of volume. Accordingly,

$$Z\rho(s)ds = \iint \rho dS \cdot ds,$$

where the integral is taken over a surface of such an area that the integral  $\int_{-D/2}^{D/2} ds \iint \rho dS$  will include a whole unit of crystal structure. That is

$$Z = \int_{-D/2}^{D/2} ds \iint \rho dS = \int_{-a/2}^{a/2} \int_{-a/2}^{a/2} \int_{-a/2}^{a/2} \rho dx dy dz, \quad (5.45a)$$

where  $a$  is the edge of the unit cube of the crystal structure. Thus

$$F_{n(hkl)} = \int_{-a/2}^{a/2} \int_{-a/2}^{a/2} \int_{-a/2}^{a/2} \rho dx dy dz \cos \left\{ 2\pi \frac{n}{a} (hx + ky + lz) \right\}. \quad (5.46)$$

If we now represent the electron density  $\rho$  by the three dimensional Fourier series,

$$\rho = \sum_{-\infty}^{\infty} \sum_{-\infty}^{\infty} \sum_{-\infty}^{\infty} A_{pqr} \cos 2\pi p \frac{x}{a} \cos 2\pi q \frac{y}{a} \cos 2\pi r \frac{z}{a}, \quad (5-46a)$$

and integrate equation (5-46) using this value of  $\rho$ , all the terms vanish except that for which

$$p = \pm nh, \quad q = \pm nk, \quad \text{and} \quad r = \pm nl.$$

We obtain thus

$$F_{n(hkl)} = A_{nh, nk, nl} \cdot a^3,$$

or writing

$$H = nh, \quad K = nk, \quad L = nl,$$

$$A_{HKL} = \frac{1}{a^3} F_{HKL}. \quad (5.47)$$

On substituting in equation (5.45a) the value of  $\rho$  given by (5.46a) we obtain

$$A_{000} = Z/a^3. \quad (5.47a)$$

The electron density at the point  $x, y, z$  is thus

$$\rho_{x, y, z} = \frac{8}{a^3} \sum_{-\infty}^{\infty} \sum_{-\infty}^{\infty} \sum_{-\infty}^{\infty} F_{HKL} \cos 2\pi H \frac{x}{a} \cos 2\pi K \frac{y}{a} \cos 2\pi L \frac{z}{a}, \quad (5.48)$$

where  $F_{HKL}$  is the experimental value of the structure factor for the  $n$ th order reflection from the  $(hkl)$  plane.

Equation (5.48) has been given by Duane (loc. cit.) on the basis of an investigation by Epstein and Ehrenfest (cf. Chapter X). Using the data for rock-salt supplied by Bragg, James and Bosanquet, Havighurst<sup>1</sup> has calculated from this expression the electron densities at different points along various lines in a rock-salt crystal. His results are shown in Fig. 78. The upper curve represents the electron density at points along a line drawn from one chlorine atom to the next, perpendicular to the (100) planes. The hump midway between the two chlorine atoms represents the sodium atom. Similarly, in accord with the rock-salt structure shown in Fig. 4.05, a line drawn along the diagonal of a cube face, as shown in curves 3 and 4, passes successively through atoms of the same kind. In curve 3 these are the chlorine atoms, and in curve 4 the sodium atoms.

Similar curves have also been calculated by Havighurst<sup>2</sup> for crystals of potassium iodide, ammonium chloride, and diamond. Though the experimental values of  $F$  for these crystals are not as precise as in the case of rock-salt, the power of this method of analysis shows itself in the fact that though no assumptions are made of the details of the crystalline structure, each atom in the lattice reveals itself by the appropriate hump in the electron density curves.

### 73. Radial Electron Distribution in Atoms

The number of electrons associated with one of the humps shown in Fig. 78 is proportional to the volume of the hump in a 4-dimensional diagram, 1 dimension representing the density and the other 3 the distance from the center of the atom along the  $X$ ,  $Y$ , and  $Z$  axes. The difficulty of evaluating such a volume numerically is obvious. However, if the atoms are assumed to have spherical symmetry, as we have seen (p. 79)

<sup>1</sup> R. J. Havighurst, Proc. Nat. Acad. Sci. 11, 502 (1925). Havighurst used the value of  $A_{000} = 0$  instead of that given by Eq. (5.47a).

<sup>2</sup> Ibid.

is probably the case within experimental error, the number of electrons in a spherical shell of radius  $r$  and thickness  $dr$  is

$$Udr = \rho \cdot 4\pi r^2 dr. \quad (5.49)$$

Thus if  $U = 4\pi r^2 \rho$  is plotted against  $r$ , the area under the curve should represent the number of electrons in the atom.

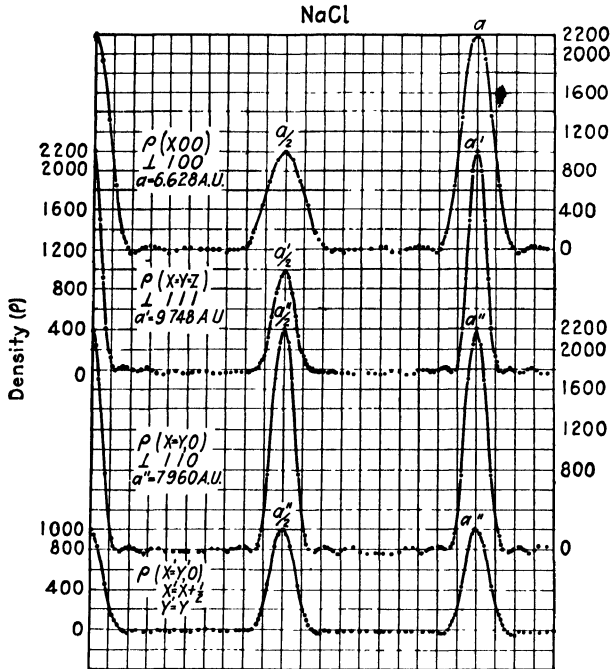

FIG. 78.

Curves of this type for sodium and chlorine, calculated by Havighurst, are shown in Fig. 79. These curves are to be compared with Bragg's curves, Figs. 71 and 72, based on the same data, but obtained by a different method.

It will be seen that the curves in which  $U$  is plotted against  $r$  differ slightly according as  $r$  is taken along a cube axis or a diagonal (see especially the curve for sodium). It is probable that a more reliable average curve can be obtained using the values of  $F$  taken from the smooth curves of Fig. 69, which

assume spherical symmetry, than using the directly measured values of  $F_{HKL}$ . It is not necessary for this purpose to evaluate a 3-dimensional Fourier series.

Let Fig. 80 be a curve, such as those shown in Figs. 75 and 76, in which the average linear density of electrons at a dis-

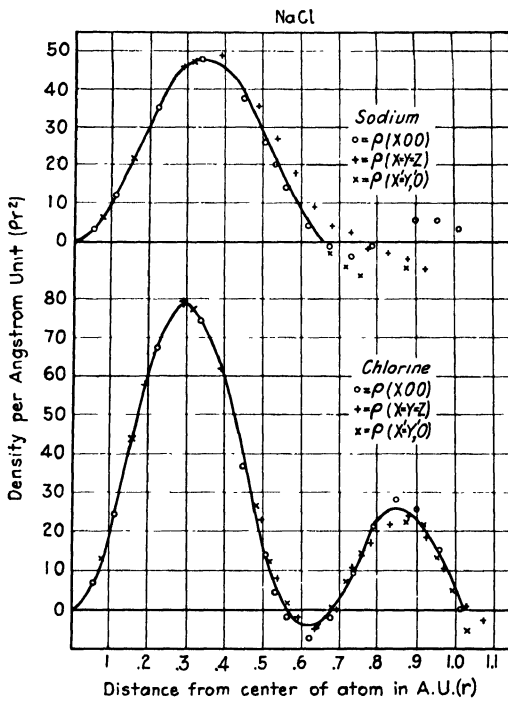

FIG. 79.

tance  $z$  from the middle of an atomic layer is plotted against  $z$ . If there are  $Udr$  electrons between  $r$  and  $r + dr$  from the center of the atom, the contribution to  $P$  due to these electrons is

$$dP = Udr \cdot p(z),$$

where  $p(z)$  is the probability that each of these electrons is at a height  $z$ . We have seen, however, equation (5.34), that for electrons at random on the surface of a sphere,  $p(z) = \frac{2}{3}r$ .

Thus

$$dP = \frac{1}{2r} Udr,$$

or

$$Udr = 2rdP. \quad (5.50)$$

The contribution of these  $Udr$  electrons to the area of the hump of Fig. 80 is thus an element of height  $dP$  and of breadth  $2z = 2r$ , the diameter of the shell. We can accordingly imagine the whole hump as made up of such elements of area, each

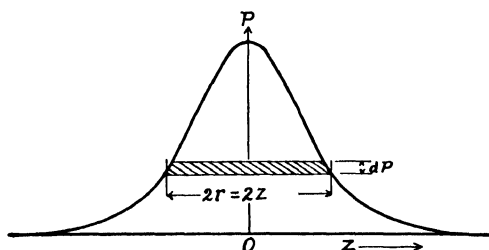

FIG. 80.

representing a number  $2zdP$  electrons on a spherical shell of radius  $r = z$  and of thickness  $dz$ .

From Fig. 80 we see that

$$dP = -\frac{dP}{dz} dz = -\frac{dP}{dz} dr,$$

since  $r = z$ . Using the value of  $P$  given by equation (5.41), and writing again  $r = z$ , we obtain,

$$-\frac{dP}{dz} = \frac{2\pi}{D} \left\{ A_1 \sin 2\pi \frac{z}{D} + 2A_2 \sin 2\pi \frac{2z}{D} + \dots \right\}.$$

Recalling that  $A_n = 2F_n/D$  (eq. 5-42), equation (5.50) thus becomes

$$Udr = 8\pi \frac{r}{D^2} \sum_1^{\infty} n F_n \sin 2\pi n \frac{r}{D} dr. \quad (5.51)$$

The values of  $F_n$  are the same as those used in evaluating  $P$ , as in Figs. 75 and 76.

The total number of electrons in the group may be obtained by integrating  $Udr$ . If the grating space  $D$  is taken so large that there is no overlapping of the atoms, the limits may be taken from 0 to  $r = D/2$ . Thus

$$\begin{aligned} Z &= \int_0^{D/2} Udr = \sum_1^{\infty} nF_n \frac{8\pi}{D^2} \int_0^{D/2} r \sin\left(\frac{2\pi n}{D}r\right) dr \\ &= -2 \sum_1^{\infty} (-1)^n F_n. \end{aligned} \quad (5.52)$$

#### 74. *Electron Distributions in Sodium, Chlorine and Aluminium*

An application of formula (5.51) to the case of rock-salt brings results of great interest. Using the experimental values of  $F$  given in Table V-2 we obtain the curves shown in Figs. 81 and 82, representing the radial distribution of the electrons in sodium and chlorine respectively. These are to be compared with Bragg's curves, Figs. 71 and 72, and Havighurst's curves shown in Fig. 79. As compared with Bragg's curves, it is clear that the present straightforward method of analysis may reveal irregularities in the electron distribution curves which may easily be overlooked when the data are analyzed by less direct methods. Bragg informs me that curves 71 and 72 represent averages over the humps shown in curves similar to those of Figs. 81 and 82, calculated by Bosanquet using practically a Fourier method. They ironed out the humps, doubting their reality. Havighurst's curves, on the other hand, limit the electron distributions to a much smaller radius than do the distributions shown in curves 71, 72 and 81, 82. This may be due to the overlapping of the successive atomic layers in the planes he has considered. It will be noted, however, that Havighurst's curve for chlorine shows humps at .3 and .8 Ångström, nearly coinciding with humps *A* and *B* in Fig. 82, and his data suggest also humps in the curve for sodium corresponding closely with those of Fig. 81.

The form of curves 81 and 82 depends somewhat upon the manner in which the  $F$  curves of Fig. 69 are extrapolated to

zero. This extrapolated portion is much more important in the present case than in Figs. 75 and 76 because of the factor  $n$  in the coefficient of each term of series (5.51), which becomes large

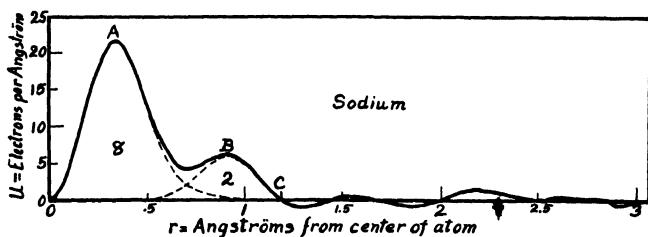

FIG. 81.

for the extrapolated values of  $F$ . Alternative extrapolations of the  $F$  values for large values of  $n$  give  $U$  curves which, while similar to Figs. 81 and 82 in their general form, differ in the position and prominence of the minor humps in the curves.

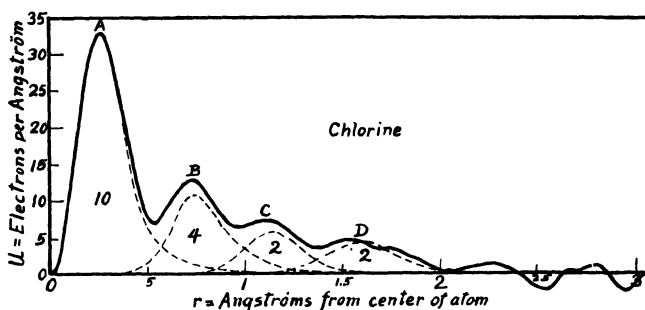

FIG. 82.

The degree of uncertainty of these curves can be estimated from the magnitude of their erratic variations. Thus in Fig. 81 a planimeter measurement shows that the total area under the curve beyond the point C is zero, so that this marks the extreme radius of the sodium ion. The irregularities in the curve beyond this point may thus be ascribed to errors of experiment and extrapolation. Those in the chlorine curve beyond 2A must be due to errors of a similar character. In view of the factor  $r$  in series (5.51), the amplitude of such erratic oscillations

of the curve should be proportional to  $r$ . It will thus be seen that errors of experiment, extrapolation, etc., may be responsible for most of the irregularities in these curves for radii greater than  $1.2\text{\AA}$ . It is improbable, however, that we can account on this basis for any considerable part of peaks  $A$  and  $B$ .

The two prominent peaks  $A$  and  $B$  of Fig. 81 can be resolved into two components as shown by the broken lines. The areas of these component humps are 8.08 and 1.92 electrons respectively. That is, this electron distribution curve represents a sodium ion consisting of 8 electrons all located so close to the center that our method does not distinguish them from each other, with two other electrons farther out, at a distance of about  $.9\text{\AA}$  from the center of the atom.

It is probable that the breadth of the peaks is due chiefly to the thermal agitation of the atom. An electron at the center of its atom would on this account be displaced on the average at an appreciable distance from the equilibrium center of the atom. Thus it is clear that all the electrons, but especially those near the center of the atom, are on the average moved by the thermal agitation to a greater distance from the point in the lattice at which the atom is in equilibrium. The scale of the atom is thus somewhat distorted, the smaller radii being magnified more than the larger radii. Of course, however, the thermal motions cannot in any way affect the area of the humps, so that our interpretation of the significance of the peaks remains unaltered.

A similar examination of Fig. 82 shows that chlorine can be considered as composed of 4 groups of electrons, 10 near the center forming peak  $A$ , 4 at  $B$ , 2 at  $C$ , and 2 at  $D$ . The radii of the latter three electron groups are about  $.74\text{\AA}$ ,  $1.14\text{\AA}$  and  $1.60\text{\AA}$ , uncorrected for thermal motion.

Some very recent experiments by Bearden<sup>1</sup> lead to values of  $F$  which differ slightly but consistently from those of Bragg, James and Bosanquet, and give a  $U$  curve for sodium in which the peak  $B$  of Fig. 81 is absent. His curves for the electron distribution in chlorine are similar to that shown in Fig.

<sup>1</sup> J. A. Bearden, Thesis, Chicago, 1926.

82, though the positions and areas of the peaks are somewhat different. In view of these differences, one cannot place much confidence in the details of the distribution curves here shown. They need to be checked by measurements on other similar substances.

As an example of such measurements, Bearden has determined the intensity of the lines diffracted by finely ground metallic aluminium. For an element the experimental values of  $F$  can be used directly in calculating the electron distributions. For this reason the data for aluminium are less subject to error than are those for sodium and chlorine, since these are based on differences and sums respectively of the  $F$  values for rock-salt. Bearden's electron distribution for aluminium is similar to those we have found for sodium and chlorine. There is an inner group of 8 electrons, surrounded by shells of 3, 1 and 1 electrons. The consistency of these results for sodium, aluminium and chlorine gives one considerable confidence at least in the general form of the electron distribution curves thus obtained.

Emphasis may well be laid upon the fact that this method of studying the distribution of electrons in atoms of a crystal involves precisely the same assumptions as does the determination of the arrangement of atoms in crystals by X-ray methods. Only greater care has to be taken in the application of the method, since we are now concerned with the ultimate details of the crystal structure. In treating these problems, however, we assume that the classical electrodynamics can be applied rigidly to phenomena of X-ray diffraction. But diffraction is a special case of scattering, and we shall see in Chapter IX that in certain large classes of phenomena of X-ray scattering the experiments depart widely from the predictions of the classical theory. Grave doubt is thus thrown upon the fundamental reflection formulas upon which the discussion in this chapter is based. The fact that the present analysis leads definitely to atoms of finite size (Figs. 75 and 76), and the reasonableness of the electron distributions at which we finally arrive serve, however, to confirm one's faith both in the experimental data and in the reliability of the method of

analysis of these data that has been developed. We seem at last to be reaping the reward of the very considerable theoretical and experimental labor that has been spent in studying the intensity of X-ray reflection.

### 75. *Effect of Temperature on X-ray Reflection*

Mention has several times been made of the fact that as the temperature of the reflecting crystal rises, the integrated reflection diminishes. This was predicted by Debye<sup>1</sup> soon after the discovery of X-ray diffraction by crystals, and was experimentally demonstrated by Bragg.<sup>2</sup> The theory of the effect has been developed in detail by Debye<sup>3</sup> and Darwin,<sup>4</sup> and from a widely different standpoint by Brillouin.<sup>5</sup> The validity of Debye's calculation has been examined also by Faxen<sup>6</sup> and Waller,<sup>7</sup> whose conclusions differ from those of Debye only in minor details. At the present writing, the experimental studies of W. H. Bragg,<sup>8</sup> Backhurst,<sup>9</sup> Jauncey,<sup>10</sup> Collins,<sup>11</sup> and James,<sup>12</sup> though showing an effect of the predicted order of magnitude, do not support the theories quantitatively. We shall therefore discuss the problem only briefly.

The electron distributions shown in Figs. 81 and 82 exhibit clearly the effect of the thermal motions of the atoms in the breadth of the peaks due to electron groups. The effect of the random thermal displacement of the atoms from their normal positions will be to introduce random phase differences between the rays scattered by the different electrons, and thus to reduce the intensity of the reflected ray. It is found pos-

<sup>1</sup> P. Debye, Verh. d. D. Phys. Ges. **15**, pp. 678, 738, 857 (1913).

<sup>2</sup> W. H. Bragg, Phil. Mag. **27**, 881 (1914).

<sup>3</sup> P. Debye, Ann. d. Phys. **43**, 49 (1914).

<sup>4</sup> C. G. Darwin, Phil. Mag. **27**, 325 (1914).

<sup>5</sup> L. Brillouin, Ann. de Phys. **17**, 88 (1922).

<sup>6</sup> H. Faxen, Z. f. Physik, **17**, 266 (1923).

<sup>7</sup> L. Waller, Z. f. Physik, **17**, 398 (1923).

<sup>8</sup> W. H. Bragg, Phil. Mag. **27**, 881 (1914).

<sup>9</sup> I. Backhurst, Proc. Roy. Soc. **102**, 340 (1922).

<sup>10</sup> G. E. M. Jauncey, Phys. Rev. **20**, 421 (1922).

<sup>11</sup> E. H. Collins, Phys. Rev. **24**, 152 (1924).

<sup>12</sup> R. W. James, Phil. Mag. **49**, 585 (1925).

sible <sup>1,2</sup> to represent the effect of the thermal agitation by introducing into the reflection formula, equation (5.16), a factor

$$D = e^{-B \sin^2 \theta}, \quad (5.53)$$

usually known as the "Debye factor." If one uses the Maxwell-Boltzmann form of the kinetic theory to calculate the atomic displacements, the constant  $B$  is

$$B = \frac{16\pi^2 k T}{f \lambda^2}, \quad (5.54)$$

where  $k$  is Boltzmann's constant,  $T$  is the absolute temperature, and  $f$  is the force on the atom per unit displacement. Using, however, Born and Karman's modification <sup>3</sup> of Debye's specific heat theory, which treats the heat motions as a series of elastic waves, Debye finds either

$$B = \frac{6h^2}{\mu k \lambda^2 \theta} \frac{\phi(x)}{x}, \quad (5.55)$$

or

$$B = \frac{6h^2}{\mu k \lambda^2 \theta} \left\{ \frac{1}{4} + \frac{\phi(x)}{x} \right\}, \quad (5.56)$$

according as he assumes respectively the absence or the existence of a zero-point energy. In these expressions  $h$  is Planck's constant,  $\mu$  is the mass of an atom,  $\theta$  is a temperature characteristic of the crystal,  $x = \theta/T$ , and  $\phi(x)$  is a function of  $\theta/T$  which Debye evaluates. According to the prevalent form of the kinetic theory, equation (5.55) should represent  $B$  the most reliably. At high temperatures this expression makes  $B$  proportional to  $T$ , as does equation (5.54); but at low temperatures  $B$  becomes proportional to  $T^2$ .

## 76. X-rays Diffusely Scattered by a Crystal

In addition to the rays which are regularly reflected from a crystal at the angle given by  $n\lambda = 2D \sin \theta$ , there are found to

<sup>1</sup> Debye, loc. cit.

<sup>2</sup> Darwin, loc. cit.

<sup>3</sup> Born and Karman, *Phys. Zeits.* **14**, 65 (1913).

be diffusely scattered rays in all directions. If the atoms in the crystal were all identical and arranged with perfect regularity, the rays at any angle other than near  $\sin^{-1} n\lambda/2D$  should be completely extinguished by interference. In view of the fact that there is a comparatively small number of electrons in each atom, it is clear that at any particular instant the arrangement of these electrons relative to the incident ray cannot be the same for all the different atoms. This introduces a type of irregularity which must make the interference incomplete even though the atoms have no thermal motion. On this account diffuse scattering will occur which is probably proportional to

$$I - e^{-A \sin^2 \theta},$$

where  $A$  is a constant independent of the temperature. Due to the thermal agitation there is, as Debye shows, an additional irregularity in the atomic positions, which results in diffusely scattered rays whose intensity is proportional to

$$I - e^{-B \sin^2 \theta},$$

where, as we have seen,  $B$  depends upon the temperature. The intensity of these scattered rays should thus depend upon the temperature according to a relation of the form

$$I_s = a(I - e^{-A \sin^2 \theta}) + b(I - e^{-B \sin^2 \theta}). \quad (5.57)$$

The experiments on the intensity of the rays reflected from crystals at different temperatures, especially the recent ones of James, show that the constant  $B$  is accurately independent of  $\theta$  and is proportional to  $1/\lambda^2$ , in accord with the equations (5.54), (5.55) and (5.56). The manner in which  $B$  is found to vary with the temperature is not, however, in even approximate agreement with the theory. Thus for the rock-salt (100) planes, James finds that

$$B_{\text{expt.}} = 1.162 \times 10^{-5} T^2 / \lambda^2, \quad (5.58)$$

whereas he calculates from equation (5.55) that

$$B_{th} = 4.89 \times 10^{-3} T / \lambda^2. \quad (5.59)$$

Thus the experimental value of  $B$  is proportional to  $T^2$ , whereas its predicted value is proportional to  $T$ .

No more satisfactory agreement has on the whole been found by other observers, though in certain isolated cases Debye's formula gives nearly correct results. Perhaps a more effective way of studying thermal motions will be to study the electron distributions at different temperatures, and thus observe more directly the magnitude of the average atomic displacements.

In the theories of the diffuse scattering by crystals developed by Debye and Faxen (*loc. cit.*) no account is taken of the first term of equation (5.57), which is due to the nearly random positions of the electrons in the individual atoms. It is thus not surprising that Jauncey's experiments show an intensity considerably greater than the value

$$I_s = C(1 - e^{-B \sin^2 \theta}) \quad (5.60)$$

predicted by Debye's theory. Jauncey finds also that the effect on this scattered intensity of increasing the temperature is much smaller than one would expect from this expression.

It is interesting to note, however, that the scattering by a crystal is found by Jauncey to approach zero at small angles, as equations (5.57) and (5.60) would both predict. Even when the temperature is raised until the substance is in the liquid form this effect remains, as is shown by Hewlett's experiments on liquid mesitylene<sup>1</sup> and Duane's<sup>2</sup> on water.

Regarding the intensity of the diffusely scattered rays, Jauncey finds that if a beam of X-rays of wave-length .71 Å and 1° broad falls on a polished (100) face of calcite at the correct angle for first order reflection, the energy in the reflected beam is greater than the whole diffusely scattered radiation by the ratio 1.4 : 1.0. The diffusely scattered rays at large angles are of about the intensity predicted by the classical theory for non-crystalline substances (Chapter III). At angles in the neighborhood of 25°, excess scattering occurs, as is predicted by Debye's

<sup>1</sup> C. W. Hewlett, *Phys. Rev.* **19**, 265 (1922).

<sup>2</sup> A. R. Duane and W. Duane, *Phys. Rev.* **20**, 86 (1922).

theory (eq. 3.21) for amorphous substances. The diffusely scattered rays are found to be less penetrating than the primary rays.<sup>1</sup>

### 77. *Effect of Magnetization on X-ray Reflection*

Anything which alters the positions of the atoms or changes the distribution of the electrons in a crystal must, in accord with the theory developed in this chapter, affect the intensity of reflection of the X-rays. According to the "molecular" theory of magnetism, when a ferro-magnetic substance is strongly magnetized, the elementary "molecular" magnets become approximately aligned in the direction of magnetization. If these elementary magnets are the chemical molecules, or other groups of atoms, one might expect magnetization to alter the atomic arrangements to such an extent that the Laue diffraction patterns would be altered.

The experiment was tried by de Broglie,<sup>2</sup> using a crystal of magnetite, immediately after the discovery of the diffraction of X-rays by crystals, and later, independently, by Compton and Trousdale.<sup>3</sup> Magnetization was found to have no effect on the positions of the Laue spots, and no noticeable effect on their intensities.

An experiment to detect a possible change in the intensity of reflection of X-rays by a magnetite crystal due to magnetization was carried out by Rognley and the author.<sup>4</sup> A balance method employing two Bragg ionization spectrometers was adopted, which was capable of detecting a change in intensity of 1 per cent, even in the fourth order. The magnetite was magnetized to about one-third of saturation, perpendicular to the reflecting surface in one experiment and parallel to the surface in another. No effect due to the magnetization was observed.

The negative result of this experiment is not easy to reconcile with theories of ferromagnetism. If one assumes that the

<sup>1</sup> G. E. M. Jauncey, *Phys. Rev.* **20**, 405 (1922).

<sup>2</sup> M. de Broglie, *Le Radium* **10**, 186 (1913).

<sup>3</sup> K. T. Compton and F. A. Trousdale, *Phys. Rev.* **5**, 315 (1915).

<sup>4</sup> A. H. Compton and O. Rognley, *Phys. Rev.* **16**, 464 (1920).

atom acts as the elementary magnet, its orientation by the magnetic field should produce a detectable effect unless it is surprisingly nearly isotropic. It is not inconsistent with the experiment to imagine that the orbits of certain of the inner electrons are turned by the magnetic field, but this is rather difficult to reconcile with the pronounced effect on magnetization of chemical conditions and mechanical jars. The absence of any effect on the intensity of reflection due to magnetization is, however, consistent with the view that the elementary magnet is a spinning electron. This suggestion has been used to account for a variety of magnetic properties of matter, and has recently been revived in connection with the interpretation of complex spectral lines.

## CHAPTER VI

### THE ABSORPTION OF X-RAYS

#### 78. *Total and True Absorption*

We are acquainted with two distinct methods by which X-ray energy is dissipated. Examination of the cloud expansion photographs obtained when X-rays traverse air reveals the existence of high speed electrons ejected from the air molecules by the X-rays. We also find that a part of the X-ray energy is spent in producing scattered rays. There is at present no evidence that the energy of the X-ray beam is spent in any other way. It is true that fluorescent radiation is produced; but as we have already seen (Chapter I) this fluorescence probably occurs as the atoms from which the electrons are ejected return to their normal condition. The primary action of the X-rays is thus to eject the electrons, and the fluorescence is a form in which part of the energy reappears which has been removed from the X-ray beam. If we let  $\tau$  represent the absorption due to the ejection of the photoelectrons and  $\sigma$  that due to the scattering, the total absorption coefficient may be written,

$$\mu = \tau + \sigma. \quad (6.01)$$

For want of a better name, we shall designate the quantity  $\tau$  the "true" absorption, and  $\sigma$  the absorption due to scattering.

Because of the presence of the scattered rays, the rate at which the intensity of a beam of X-rays decreases with the thickness of the absorbing screen traversed depends upon the geometrical conditions as well as upon the material and wavelength. If the beam is narrow, nearly all of the scattered energy will fall outside of the main beam; but if the beam is broad, much of the scattered energy will remain within the main beam

and add to its intensity. This effect of the scattered rays is well illustrated in the curves shown in Figs. 83 and 84, representing data obtained by Bachem.<sup>1</sup> Fig. 83 shows the intensity of the X-rays at various positions in a deep water bath when the water is irradiated from above by hard X-rays (200 kv., 1 mm. copper filter) passing through an opening 20 cm in diameter. The curves of Fig. 84 are exactly similar except that the diameter of the incident beam is 5 cm. It will be seen that

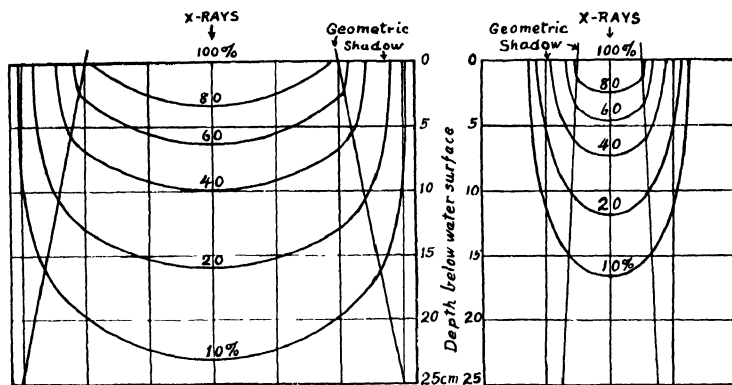

FIG. 83.

FIG. 84.

because of the presence of a greater amount of scattered rays, the intensity falls off less rapidly for the broader beam. This is accompanied also by a greater intensity outside the geometrical shadow, due to the scattered rays when the broader opening is used. Bachem finds<sup>1</sup> that under the conditions of Fig. 83, at the surface of the water 33 per cent of the X-rays are secondary rays coming back from the water, while at a depth of 20 cm. 85 per cent of the X-rays are secondary, only 15 per cent coming directly from the primary beam.

For a narrow X-ray beam it is clearly the coefficient of total absorption  $\mu$  which determines the rate of energy decrease, and for a broad beam it is a coefficient intermediate between  $\mu$  and  $\tau$ , since only a portion of the secondary beam remains within the direct beam.

<sup>1</sup> A. Bachem, "Principles of X-ray and Radium Dosage," Chicago, 1923, pp. 152

We have defined the absorption coefficient, or more specifically the “*linear*” *absorption coefficient*, as the fraction of the incident energy which is absorbed per centimeter of matter traversed, that is,

$$\mu = - \frac{dI/I}{dx}. \quad (6.02)$$

If we consider a beam of 1 square centimeter cross section, this is the fraction of the energy absorbed per cubic centimeter of matter traversed. If the density is  $\rho$  grams per cm.<sup>3</sup>, the fraction of the energy absorbed per gram is of course  $\mu_m = \mu/\rho$ , which is called the *mass absorption coefficient*. Similarly, if there are a number  $n$  atoms per cm.<sup>3</sup>, the fraction of the energy absorbed per atom is  $\mu_a = \mu/n$ , which is called the *atomic absorption coefficient*.

### 79. The Measurement of Absorption Coefficients

In order to obtain precise measurements of the absorption coefficients it is necessary to use homogeneous X-rays. For if more than one wave-length is present, the longer waves will be strongly absorbed by the first portions of the absorption screen, making the fraction of the energy removed per unit path decrease with the thickness traversed. If  $I$  is the intensity of the beam after traversing a thickness  $x$ , and if  $I_0$  is its intensity if the screen is removed, we found (1.01) that  $I = I_0 e^{-\mu x}$ , whence

$$\mu = \frac{1}{x} \log \frac{I_0}{I}. \quad (6.03)$$

But equation (1.01) was based upon the assumption that  $\mu$  as defined in equation (6.02) is independent of  $x$ , so that equation (6.03) can be used to calculate the coefficient strictly only in case the wave-length is constant.

We may however speak of the “effective” absorption coefficient of a heterogeneous beam of X-rays, meaning usually the value calculated from equation (6.02) for some particular value of  $x$ . This effective value approaches a maximum limit for small values of  $x$ , which depends upon the distribution of wave-lengths in the incident beam.

The homogeneity required to make accurate measurements of the absorption coefficients may be secured in either of two ways. In his early experiments,<sup>1</sup> Barkla secured nearly homogeneous rays by exciting the secondary fluorescent radiation of various elements. Thus, for example, hard X-rays were allowed to fall successively upon chromium, manganese, iron, etc. The absorption of the fluorescent X-rays from these elements in various substances was then examined. As we now know (see p. 25, §7), the *K* radiation from these elements is not strictly homogeneous, but consists rather of two prominent components whose wave-lengths differ by 10 or 15 per cent. But the rays thus obtained were practically free from the radiation which forms the continuous spectrum of the primary beam, so that this work marked a great advance.

With the advent of crystal spectrometry, it became a comparatively simple matter to secure nearly homogeneous X-rays. The apparatus used by Bragg and Peirce<sup>2</sup> and in most of the later absorption measurements is shown diagrammatically in Fig. 85. From the crystal *C*, preferably of calcite in order to obtain a pure spectrum, a ray is reflected to the ionization chamber *I*. Early experiments by Moseley and Darwin<sup>3</sup> and recent ones by Woo<sup>4</sup> have shown that it makes no difference whether the absorption screen is placed at *A* in the path of the direct beam or at *B* in the path of the reflected beam, though usually the screen has been used at *B*.

It will be seen that this arrangement satisfies the geometrical conditions for measuring the total absorption, for the ray reflected from the crystal is necessarily narrow, and the aperture of the ionization chamber is ordinarily small. Of course if the absorption screen were placed against the window of the ionization chamber, an appreciable amount of scattered radiation might enter, but this will not occur if the screen is placed near the crystal.

<sup>1</sup> C. G. Barkla, *Phil. Mag.* **22**, 396 (1911).

<sup>2</sup> W. H. Bragg and S. E. Peirce, *Phil. Mag.* **28**, 626 (1914).

<sup>3</sup> H. G. J. Moseley and C. G. Darwin, *Phil. Mag.* **26**, 211 (1913).

<sup>4</sup> Y. H. Woo, *Proc. Nat. Acad.* **10**, 145 (1924).

If  $\lambda_\theta$  is the wave-length of the first order ray reflected at the angle  $\theta$ , rays may also appear whose wave-lengths are  $\lambda/2$ ,  $\lambda/3$ , etc. These higher orders can be eliminated by taking the precaution of operating the X-ray tube at a potential too low to excite the wave-length  $\lambda_\theta/2$ . This condition is satisfied if  $V_{\max.} < 2hc/e\lambda_\theta$ , where  $V_{\max.}$  is the maximum potential applied to the tube. There is thus a sufficient margin of potential to make possible the excitation of the desired wave-length with a considerable intensity.

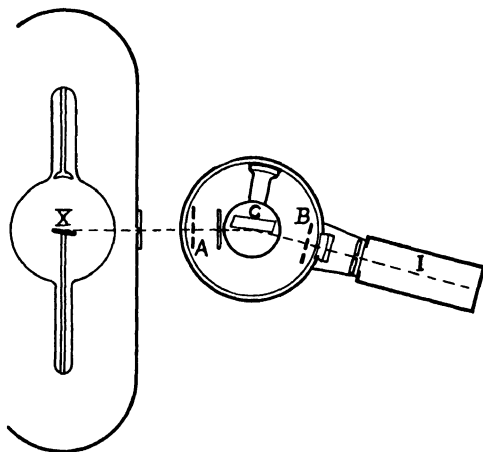

FIG. 85.

The shape and purity of the absorbing screen are also of great importance when precise absorption measurements are to be made. In view of the rapid increase in absorption coefficient with atomic number, even a very small impurity of a heavy element may increase greatly the absorption by a light element such as carbon or aluminium. In the case of the heavy elements, especially for the greater wave-lengths, the absorbing screen must be so thin that it is very difficult to secure uniform thickness. The effect of non-uniformity is to give an apparent absorption coefficient smaller than the true value.

#### 80. *Tables of Absorption Coefficients*

The following tables give the absorption coefficients of X-rays of various wave-lengths in different elements:

TABLE

MASS ABSORPTION COEFFICIENTS OF THE ELEMENTS FOR

Element	Authority	WAVE-LENGTH									
		.080	.100	.125	.150	.175	.200	.250	.300	.350	.400
1 H	ODS	.....	.....	.....	.....	.....	.....	.39	.42	.44	.45
	H	.....	.....	.3	.3	.3	.3	.3	.3	.2	.3
3 Li	H	.....	.....	.....	.....	.....	.....	.....	.172	.188	.208
6 C	H	.....	.144	.154	.163	.166	.173	.187	.202	.219	.240
	ODS	.....	.....	.....	.....	.....	.....	.185	.197	.210	.240
	A	.149	.159	.151	.153	.155	.160	.173	.190	.213	.245
	B	.....	.....	.....	.....	.....	.....	.....	.....	.....	.....
7 N	H	.....	.....	.....	.163	.171	.177	.193	.224	.251	.....
8 O	H	.....	.....	.146	.163	.174	.183	.207	.243	.289	.336
	ODS	.....	.....	.....	.....	.....	.....	.209	.238	.281	.339
12 Mg	A	.....	.....	.162	.175	.202	.232	.311	.430	.612	.875
	B	.....	.....	.....	.....	.....	.....	.....	.....	.....	.....
13 Al	A	.143	.168	.174	.203	.236	.275	.382	.545	.786	1 11
	R	.....	.....	.181	.198	.221	.259	.370	.532	.761	1 06
	D	.....	.162	.....	.....	.....	.....	.....	.....	.....	.....
	H	.....	.....	.174	.200	.236	.273	.358	.517	.710	.982
	HR	.....	.....	.....	.158	.202	.246	.357	.518	.718	.95
	BP	.....	.....	.....	.....	.....	.....	.....	.....	.....	.....
	B	.....	.....	.....	.....	.....	.....	.....	.....	.....	.....
16 S	A	.152	.190	.204	.272	.333	.42	.63	.93	1 32	1 78
20 Fe	RW	.....	.....	.39	.55	.77	1 06	1 90	3 15	.....	.....
	H	.....	.....	.309	.585	.82	1 06	1 88	3 09	4 77	7 02
	A	.232	.275	.404	.580	.79	1 07	1 98	3 30	5 02	7 25
	BP	.....	.....	.....	.....	.....	.....	.....	.....	.....	.....
	B	.....	.....	.....	.....	.....	.....	.....	.....	.....	.....
27 Co	RW	.....	.....	.42	.60	.84	1 17	2 12	3 52	.....	.....
28 Ni	RW	.....	.....	.48	.69	.98	1 36	2 46	4 11	.....	.....
	A	.261	.328	.472	.670	1 02	1 45	2 55	4 10	6 22	.....
	BP	.....	.....	.....	.....	.....	.....	.....	.....	.....	.....
	B	.....	.....	.....	.....	.....	.....	.....	.....	.....	.....
29 Cu	A	.263	.326	.501	.765	1 11	1 55	2 77	4 50	6 06	10 2
	R	.....	.....	.46	.79	1 13	1 56	2 77	4 50	6 95	10 1
	RW	.....	.....	.50	.72	1 02	1 43	2 59	4 33	.....	.....
	D	.....	.32	.....	.....	.....	.....	.....	.....	.....	.....
	BP	.....	.....	.....	.....	.....	.....	.....	.....	.....	.....
	B	.....	.....	.....	.....	.....	.....	.....	.....	.....	.....
30 Zn	A	.305	.380	.600	.92	1 28	1 77	3 15	5 10	7 90	11 6
	BP	.....	.....	.....	.....	.....	.....	.....	.....	.....	.....
	B	.....	.....	.....	.....	.....	.....	.....	.....	.....	.....
42 Mo	BP	.....	.....	1 35	1 96	2 83	4 02	7 42	12 7	19 1	26 7
46 Pd	BP	.....	.....	.....	.....	.....	.....	.....	.....	.....	.....
47 Ag	A	.72	1 13	1 67	2 63	3 84	5 60	10 9	17 9	26 8	38 2
	R	.....	.....	.....	.....	3 69	6 00	11 4	18 2	27 2	38 6
	BP	.....	.....	.....	.....	.....	.....	.....	.....	.....	.....
	B	.....	.....	.....	.....	.....	.....	.....	.....	.....	.....
50 Sn	A	.78	1 16	2 01	3 10	4 44	6 00	12 0	18 9	.....	.....
	BP	.....	.....	.....	.....	.....	.....	.....	.....	.....	.....
	B	.....	.....	.....	.....	.....	.....	.....	.....	.....	.....
74 W	A	2 35	3 40	5 27	7 92	2 92	3 50	5 62	8 60	13 2	19 8
78 Pt	A	2 46	3 69	5 70	.....	3 10	4 14	7 37	11 5	17 0	24 5
	BP	.....	.....	.....	.....	.....	.....	.....	.....	.....	.....
	B	.....	.....	.....	.....	.....	.....	.....	.....	.....	.....
79 Au	A	2 39	3 64	5 42	.....	3 11	4 28	7 75	.....	.....	.....
	BP	.....	.....	.....	.....	.....	.....	.....	.....	.....	.....
	B	.....	.....	.....	.....	.....	.....	.....	.....	.....	.....
82 Pb	A	2 47	3 78	5 22	2 42	3 35	4 78	8 42	13 6	21 3	31 8
	R	.....	.....	.....	.....	2 55	4 60	8 48	14 2	22 6	33 6
	HR	.....	.....	3 0	1 57	2 40	3 45	6 0	11 9	.....	.....
83 Bi	A	2 44	3 78	.....	2 45	3 59	5 00	9 34	14 8	22 8	.....
90 Th	A	.....	3 88	1 85	2 69	3 87	5 47	9 67	.....	.....	.....

## REFERENCES:

ODS = A. R. Olson, E. Dershem and H. H. Storch, Phys. Rev. 21, 30 (1923).

H = C. W. Hewlett, Phys. Rev. 17, 284 (1921).

A = S. J. M. Allen, Phys. Rev. 24, 1 (1924); 27, 266 (1926). The author is indebted to Prof. Allen for sending him his unpublished data for wave-lengths greater than .7A.

B = C. G. Barkla, Phil. Mag. 22, 396 (1911).

R = F. K. Richtmyer, Phys. Rev. 18; 13 (1921).

VI-1

DIFFERENT WAVE-LENGTHS, ACCORDING TO DIFFERENT OBSERVERS

IN ÅNGSTRÖM											Element
.500	.600	.700	800	900	1 00	1.10	1.32	1.40	1 76	2 25	
.45	.44	.46	.51	57	.63	.....	.....	.....	.....	.....	H 1
.5	.5	.6	1 0	.....	.....	.....	.....	.....	.....	.....	Li 3
.245	.306	.403	.....	.....	.....	.....	.....	.....	.....	.....	C 6
.304	.394	.532	.706	.954	1 27	.....	.....	.....	.....	.....	
.305	.400	.529	.698	.914	1 19	.....	.....	.....	.....	.....	
.329	.472	.60	.....	1.16	1.50	2.0	3.4	3.9	7 5	.....	
.....	.....	.....	.....	.....	.....	2.3	.....	4.3	8.0	15.3	
.....	.....	.....	.....	.....	.....	.....	.....	.....	.....	.....	N 7
.488	.730	1 08	1.53	.....	.....	.....	.....	.....	.....	.....	O 8
.509	.762	1 12	1 58	2 18	2 95	.....	.....	.....	.....	.....	
1 56	.....	.....	.....	.....	.....	.....	.....	.....	.....	.....	Mg 12
.....	.....	.....	.....	.....	.....	16	.....	35	63	126	
1 94	3 25	5 05	.....	10.1	14 1	19 0	32 2	37	75	.....	Al 13
1 92	3 23	5 05	.....	.....	.....	.....	.....	.....	.....	.....	
.....	.....	.....	.....	.....	.....	.....	.....	.....	.....	.....	
1 86	3 05	4 84	7 20	10 3	13 8	.....	.....	.....	.....	.....	
.....	.....	.....	.....	.....	.....	.....	.....	.....	.....	.....	
2 02	3 35	.....	.....	9 6	13 8	20.8	30 8	.....	.....	.....	
.....	.....	.....	.....	.....	.....	20	.....	39	72	136	
.....	5 9	9.5	.....	.....	.....	.....	.....	.....	.....	.....	S 16
.....	.....	.....	.....	.....	.....	.....	.....	.....	.....	.....	Fe 26
13 9	22 6	35 3	50 7	68 2	90 2	.....	.....	.....	.....	.....	
.....	.....	36 7	.....	70	102	131	230	270	57	.....	
15 2	24 3	.....	.....	68	93	125	205	.....	.....	.....	
.....	.....	.....	.....	.....	.....	121	.....	268	67	104	
.....	.....	.....	.....	.....	.....	.....	.....	.....	.....	.....	Co 27
.....	.....	.....	.....	.....	.....	.....	.....	.....	.....	.....	Ni 28
.....	.....	.....	.....	.....	.....	.....	.....	.....	.....	.....	
18 9	30 7	.....	.....	82	118	151	256	300	70	.....	
.....	.....	.....	.....	.....	.....	167	250	.....	.....	.....	
.....	.....	.....	.....	.....	.....	118	.....	.....	.....	.....	
19 0	32 2	49.6	.....	95	133	169	.....	205	67	129	Cu 29
18 8	31 6	48.8	.....	.....	.....	.....	.....	39	77	.....	
.....	.....	.....	.....	.....	.....	.....	.....	.....	.....	.....	
.....	.....	.....	.....	.....	.....	.....	.....	.....	.....	.....	
21 5	32 4	.....	.....	100	134	186	273	.....	.....	.....	
.....	.....	.....	.....	.....	.....	159	.....	55	75	143	
22 0	37 5	57 0	.....	107	152	190	41 0	46 4	92	.....	Zn 30
22 7	30 6	.....	.....	.....	.....	.....	39 1	.....	.....	.....	
.....	.....	.....	.....	.....	.....	.....	.....	50	91	170	
48 6	80 7	18 8	27 2	37 5	51	.....	.....	.....	.....	.....	
60	17 0	.....	.....	.....	.....	.....	.....	.....	.....	.....	Mo 42
10 5	17.8	25 6	.....	53	73	97	158	178	331	.....	Pd 46
11 5	19 6	.....	.....	.....	.....	.....	.....	.....	.....	.....	Ag 47
10 8	18 4	.....	.....	61	76	86	152	.....	.....	.....	
.....	.....	.....	.....	.....	.....	92	.....	175	314	580	
11 6	.....	31 0	.....	63	87	115	198	220	410	.....	Sn 50
13 1	21 6	.....	.....	68	87	107	.....	.....	.....	.....	
.....	.....	.....	.....	.....	.....	118	.....	225	302	714	
38 0	65	.....	.....	.....	.....	.....	113	141	.....	.....	W 74
45 5	75 5	112	.....	158	165	89	141	160	283	.....	Pt 78
48 5	75 0	.....	.....	.....	.....	92	145	.....	.....	.....	
.....	.....	.....	.....	.....	.....	97	.....	162	281	517	
.....	.....	116	.....	154	110	90	148	168	.....	.....	Au 79
.....	.....	.....	.....	.....	.....	98	.....	.....	.....	.....	
51	77	.....	.....	.....	.....	102	.....	178	306	507	
58 0	89	133	.....	140	77	100	166	185	340	.....	Pb 82
60 6	.....	.....	.....	.....	.....	.....	.....	.....	.....	.....	
.....	.....	.....	.....	.....	.....	.....	.....	.....	.....	.....	
.....	.....	.....	.....	.....	.....	.....	.....	.....	.....	.....	Bi 83
.....	.....	.....	.....	.....	.....	.....	.....	.....	.....	.....	Th 90

D = W. Duane, Proc. Nat. Acad., March, 1922.  
 HR = A. W. Hull and M. Rice, Phys. Rev. 8, 836 (1916).  
 BP = W. H. Bragg and S. E. Peirce, Phil. Mag. 28, 626 (1914).  
 RW = F. K. Richtmyer and F. W. Warburton, Phys. Rev. 22, 539 (1923).  
 For additional data, cf. Glocker, Phys. Zeits. 19, 66 (1918); Owen, Proc. Roy. Soc. 94, 510 (1918); Williams, Proc. Roy. Soc., 94, 571 (1918) and Wooten, Phys. Rev. 13, 71 (1919).

TABLE VI-2

MASS AND ATOMIC ABSORPTION COEFFICIENTS OF THE ELEMENTS FOR  $\lambda = 0.710\text{\AA}$   
(MOLYBDENUM  $K\alpha$  LINE)

Element	Authority	$\mu_m$	$\mu_a$
1 H	T	.28	.047
6 C	A	.68	1.34
	W	.667	1.32
7 N	T	.569	1.13
	W	1.072	2.48
8 O	W	1.00	2.64
	T	1.15	3.04
11 Na	W	3.39	12.9
12 Mg	W	4.60	18.5
13 Al	A	5.35	23.8
	W	5.28	23.5
15 P	W	8.28	42.4
16 S	A	9.9	52.4
	W	8.83	46.7
17 Cl	W	11.7	68.5
19 K	W	16.2	105
20 Ca	W	20.2	133
24 Cr	W	30.0	257
25 Mn	W	34.7	315
26 Fe	W	36.9	340
27 Co	W	38.1	371
28 Ni	W	48.2	467
	A	53.7	563
29 Cu	W	46.3	486
	A	60.0	647
30 Zn	W	55.2	596
	W	67.2	887
35 Br	W	94.3	1360
38 Sr	W	99.5	1470
39 Y	W	19.7	295
42 Mo	W	20.5	324
47 Ag	A	28.5	507
	W	30.8	548
48 Cd	W	30.3	562
50 Sn	W	35.0	686
53 I	W	39.8	833
56 Ba	W	41.4	938
78 Pt	A	119	3830
79 Au	W	101	3280
82 Pb	A	140	4790
	W	102	3480

## REFERENCES:

- T = E. G. Taylor, Phys. Rev. 20, 700 (1922).  
 A = S. J. M. Allen, Phys. Rev. 24, 1 (1924).  
 W = K. A. Wingardh, Zeits. f. Phys. 8, 363 (1922).

TABLE VI-3

MASS, ATOMIC AND ELECTRONIC ABSORPTION COEFFICIENTS OF THE ELEMENTS FOR  $\gamma$  RAYS FROM RADIUM C, FILTERED THROUGH 1 CM. OF LEAD

( $\lambda = .017A$  approx.)

Element	$\mu_m$ Ahmad	$\mu_m$ O F F	$\mu_m$ Ishino	$\mu_a$ $\times 10^{23}$	$\mu_e = \mu_a/Z$ $\times 10^{25}$
1 H	.117	....	....	.0195	1.95
6 C	.0599	....	....	.118	1.97
8 O	.0591	....	....	.156	1.95
12 Mg	....	.0566	....	.227	1.88
13 Al	.0575	.0559	.0659	.256	1.97
16 S	.0579	....	....	.318	1.98
26 Fe	.0575	....	.0632	.529	2.03
28 Ni	.0589	....	....	.570	2.04
29 Cu	.0570	....	....	.598	2.06
30 Zn	.0569	.0567	....	.613	2.04
47 Ag	.0557	....	....	.990	2.11
50 Sn	.0557	.0525	....	1.06	2.13
78 Pt	.0680	....	....	2.15	2.76
80 Hg	.0702	....	....	2.29	2.87
82 Pb	.0681	.0633	.0727	2.29	2.76
83 Bi	.0705	....	....	2.39	2.89
90 Th	.0810	....	....	3.07	3.41
92 U	.0826	....	....	3.21	3.49

REFERENCES:

~ N Ahmad, Proc Roy Soc 105, 507 (1924); 109, 206 (1925)

E A Owen, N Fleming, W E. Fage, Proc Phys Soc London 36, 355 (1924).

M Ishino, Phil Mag 33, 140 (1917)

The values quoted from Ishino's work are corrected for a slight error in estimating the scattering coefficient

The values of  $\mu_a$  and  $\mu_e$  are calculated from Ahmad's values of  $\mu_m$ , except in the case of Mg, or which O F F's value is used.

TABLE VI-4

ABSORPTION COEFFICIENTS FOR SCATTERED  $\gamma$ -RAYS

Element	$\mu_m$			$\mu_a$			$\mu_e = \mu_a/Z$		
	.023A	.041A	.057A	.023A	.041A	.057A	.023A	.041A	.057A
13 Al	.....	.....	.07	.....	.....	.30 $\times 10^{-23}$	.....	.....	2.4 $\times 10^{-25}$
26 Fe	.....	.....	.08	.....	.....	.74	.....	.....	2.8
50 Sn	.....	.....	.18	.....	.....	3.5	.....	.....	6.1
82 Pb	.11	.21	.50	3.7	7.1	17	4.6	8.9	21

REFERENCE: A. H. Compton, Phil Mag. 41, 760 (1921), with wave-lengths calculated from equation (9.04), assuming  $\lambda_0 = .017A$ .

TABLE

MEAN VALUES OF THE MASS ABSORPTION COEFFICIENTS

Element	WAVE-LENGTH											
	.017	.057	.080	.100	.125	.150	.175	200	250	300	350	.400
1 H	.117	...	...	...	.3	.4	.4	.4	.39	.42	.44	.45
3 Li	...	...	...	...	...	...	...	...	...	.172	.188	.208
6 C	.060	...	.140	.146	.152	.160	.162	.170	.184	.197	.210	.240
7 N	...	...	...	...	...	.163	.171	.177	.193	.224	.251	...
8 O	.059	...	...	...	.146	.163	.174	.183	.208	.240	.285	.338
12 Mg	.057	...	...	...	.162	.175	.202	.232	.311	.430	.612	.875
13 Al	.058	.07	.143	.164	.178	.201	.231	.269	.370	.531	.756	1.05
16 S	.058	...	.152	.190	.204	.272	.333	.42	.63	.93	1.32	1.78
26 Fe	.058	.08	.232	.265	.399	.572	.79	1.07	1.93	3.18	4.94	7.17
27 Co	...	...	...	...	.42	.60	.84	1.07	2.12	3.52	...	...
28 Ni	.059	...	.261	.328	.475	.68	1.00	1.40	2.50	4.10	6.22	...
29 Cu	.057	...	.263	.323	.49	.77	1.10	1.53	2.75	4.47	6.91	10.1
30 Zn	.057	...	.305	.38	.60	.92	1.28	1.77	3.15	5.10	7.90	11.6
42 Mo	...	...	...	...	1.35	1.96	2.83	4.02	7.42	12.7	19.1	26.7
46 Pd	...	...	...	...	...	...	...	...	...	...	...	...
47 Ag	.056	...	.72	1.13	1.67	2.63	3.76	5.75	11.1	18.0	27.0	38.4
50 Sn	.056	.18	.78	1.16	2.00	3.00	4.35	6.30	12.1	...	...	...
74 W	...	...	2.35	3.40	5.42	8.10	2.92	3.20	5.60	8.60	13.2	19.8
78 Pt	.068	...	2.46	3.69	5.70	4.30	3.04	4.16	7.32	11.5	17.0	24.5
79 Au	...	...	2.39	3.64	5.37	3.60	3.09	4.28	7.65	...	...	...
82 Pb	.068	.50	2.47	3.78	4.32	2.0	2.93	4.62	8.16	13.9	21.9	32.7
83 Bi	.070	...	2.44	3.78	3.8	2.44	3.59	5.10	9.3	14.8	22.8	...
90 Th	.081	...	...	3.88	1.85	2.69	3.87	5.47	9.67	...	...	...

K Limit

TABLE

ATOMIC ABSORPTION COEFFICIENTS OF THE

Element	WAVE-LENGTH											
	.017	.057	.080	.100	.125	.150	.175	.200	250	300	.350	.400
1 H	.020	...	...	...	.05	.07	.07	.07	.065	.070	.073	.075
3 Li	...	...	...	...	...	...	...	...	...	.107	.215	.238
6 C	.118	...	.277	.289	.301	.317	.321	.337	.365	.390	.428	.475
7 N	...	...	...	...	...	.377	.395	.409	.440	.518	.580	...
8 O	.156	...	...	...	.385	.430	.459	.483	.549	.634	.752	.802
12 Mg	.227	...	...	...	.650	.702	.811	.931	1.25	1.72	2.46	3.51
13 Al	.256	.30	.640	.730	.795	.900	1.03	1.20	1.65	2.30	3.37	4.68
16 S	.318	...	.80	1.01	1.08	1.43	1.75	2.22	3.33	4.92	6.98	9.42
26 Fe	.529	.74	2.14	2.44	3.68	5.27	7.28	9.77	17.8	29.3	45.5	66.1
27 Co	...	...	...	...	4.09	5.84	8.17	11.4	20.6	34.3	...	...
28 Ni	.570	...	2.54	3.19	4.60	6.58	9.68	13.6	24.2	39.7	60.2	...
29 Cu	.598	...	2.76	3.38	5.12	8.06	11.5	16.0	28.8	46.9	72.5	106
30 Zn	.613	...	3.34	4.1	6.5	9.9	13.8	19.1	34.0	55.0	85.2	125
42 Mo	...	...	...	...	21.4	31.0	44.8	63.7	117	201	302	423
46 Pd	...	...	...	...	...	...	...	...	...	...	...	...
47 Ag	.990	...	12.8	20.1	20.7	46.8	66.9	102	198	320	481	684
50 Sn	1.06	3.5	15.0	22.2	38.3	57.5	83.5	121	232	...	...	...
74 W	...	...	71	103	165	246	88.5	97.0	170	261	398	601
78 Pt	2.15	...	79	118	184	138	97.9	139	236	370	548	789
79 Au	...	...	78	118	175	117	101	139	249	...	...	...
82 Pb	2.20	17	85	129	148	68	101	158	289	475	740	1120
83 Bi	2.39	...	84	130	131	84	124	176	321	510	785	...
90 Th	3.07	...	...	155	72	105	151	216	376	...	...	...

K Limit



In Table VI-1 I have interpolated between the values given in the original papers to obtain the values for the wave-lengths desired.

### 81. *Critical Absorption Wave-lengths*

The most prominent characteristics of the absorption coefficients as functions of the wave-length and the atomic number are shown in Figs. 86 and 87. In Fig. 86 is shown the manner in which a given element, in this case platinum, absorbs radiation of different wave-lengths. In general the absorption coefficient increases rapidly with an increase of wave-length. There exist, however, certain critical regions in which for a slightly increased wave-length there is a sudden decrease in absorption. The wave-lengths at which such sudden changes occur are known as the critical absorption wave-lengths. It is found that if the wave-length of the radiation is shorter than the shortest of these critical wave-lengths, the complete X-ray spectrum of the absorbing element is excited, including the characteristic *K* radiation.<sup>1</sup> A slightly longer wave will excite only the characteristic fluorescent *L*, *M*, etc., radiations, but not that of the *K* type. Similarly there are three critical absorption wave-lengths associated with the *L* series, at each of which a separate portion of the emission spectrum of the *L* series disappears, until at wave-lengths longer than 1.07A no fluorescent *L* radiation is excited. Experiment shows<sup>2</sup> that the critical absorption wave-length associated with any X-ray spectral series is very slightly shorter than the shortest emission wave-length of the series. Thus any element is especially transparent to its own characteristic radiation.

Figure 87 shows the absorption per atom of X-rays of wave-length 1.00A in the different elements. The rapid increase of the absorption with the atomic number is prominent. But here again there exist the critical points at which sudden decreases in the absorption occur. Thus arsenic, of atomic num-

<sup>1</sup> C. G. Barkla, *Phil. Mag.* 22, 396 (1911).

<sup>2</sup> D. L. Webster, *Phys. Rev.* 7, 599 (1916).

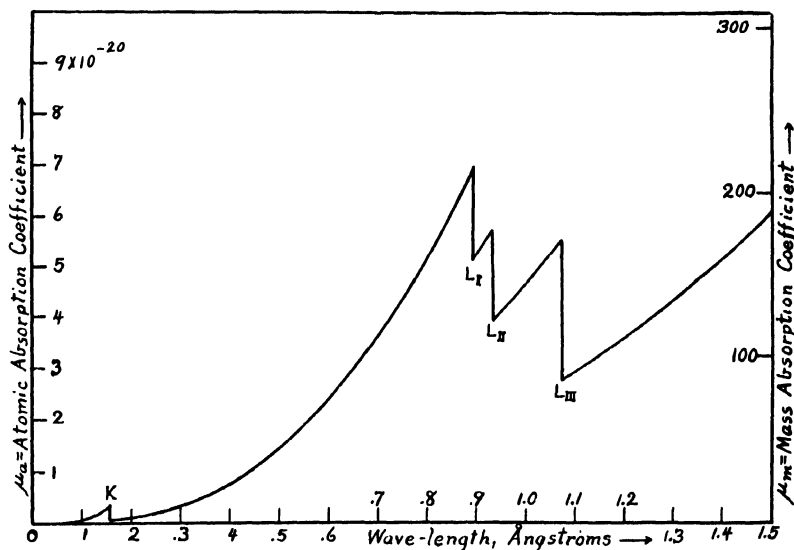

FIG. 86.

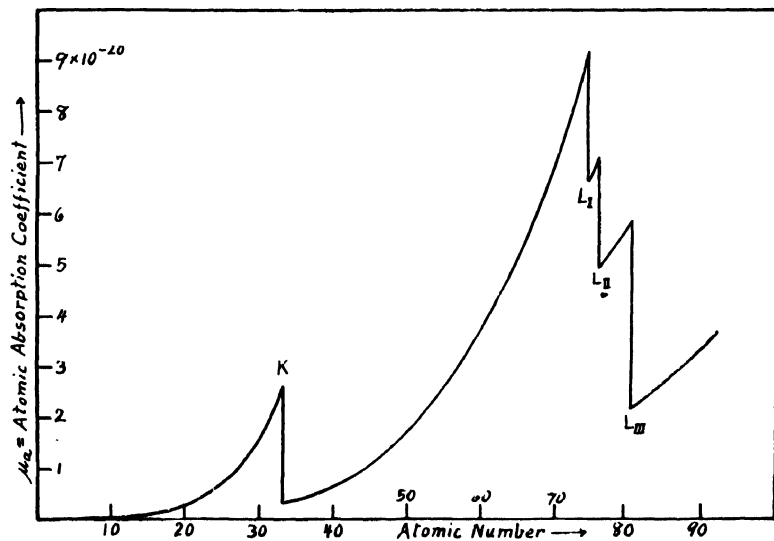

FIG. 87.

ber 33, absorbs this wave-length much more strongly than does selenium, of number 34, corresponding to the fact that rays of 1A wave-length will excite the characteristic *K* radiation of arsenic but not of selenium. Similarly there exist critical atomic numbers for the *L* series in the neighborhood of platinum ( $Z = 78$ ).

Critical absorption wave-lengths have been observed corresponding not only to the *K* and *L* series of the absorber but to its *M* series as well in the case of the very heavy elements.

Some discussion has arisen with regard to the existence of a critical absorption of a shorter wave-length than the *K* radiation, which could be ascribed to a possible *J* radiation. Several experimenters, including Barkla and White,<sup>1</sup> Williams,<sup>2</sup> Owen<sup>3</sup> and Dauvillier,<sup>4</sup> have obtained evidence which they have taken to indicate the existence of such critical wave-lengths; and Laub<sup>5</sup> and Crowther<sup>6</sup> have observed penetrating secondary radiation which they have attributed to this source. This secondary radiation, however, has no definite wave-length characteristic of the radiating element, and is explicable as scattered radiation whose wave-length has been changed as described above (p. III, 15). Furthermore the agreement is not good between the values given by different observers for their critical *J* wave-lengths. The careful measurements of Richtmyer and Grant<sup>7</sup> and those quoted in Table VI-1 have shown no indication whatever of these supposed critical wave-lengths. And finally an examination of the radiation from an X-ray tube with an aluminium target led Duane and Shimizu to conclude<sup>8</sup> that "aluminium has no characteristic lines in its emission spectrum between the wave-lengths  $\lambda = .1820A$  and  $1.259A$  that amount to as much as 2 per cent of the general

<sup>1</sup> Barkla and White, *Phil. Mag.* **34**, 270 (1917).

<sup>2</sup> Williams, *Proc. Roy. Soc.* **94**, 567 (1918).

<sup>3</sup> E. A. Owen, *Proc. Roy. Soc.*, **94**, 339 (1918).

<sup>4</sup> Dauvillier, *Ann. de Phys.* **14**, 49 (1920).

<sup>5</sup> J. Laub, *Ann. der Phys.* **46**, 785 (1915).

<sup>6</sup> J. A. Crowther, *Phil. Mag.* **42**, 719 (1921).

<sup>7</sup> Richtmyer and Grant, *Phys. Rev.* **15**, 547 (1920).

<sup>8</sup> Duane and Shimizu, *Phys. Rev.* **13**, 288 (1919); **14**, 389 (1919).

radiation in the neighborhood." The evidence is thus strongly against the existence of a characteristic *J* radiation.<sup>1</sup>

### 82. *Table of Critical Absorption Wave-lengths*

The wave-lengths of the critical absorption limits for different elements are given in the following table. The values in italics are direct determinations from X-ray absorption spectra. Other values are calculated, some from the wave-lengths of the spectrum lines (see p. 330), some from critical potentials for exciting soft X-rays, some from ultraviolet spectra, and a few are interpolated.

### 83. *Empirical Absorption Formulas*

An empirical absorption formula which has been found to express fairly satisfactorily the absorption by all elements of atomic number greater than 5 for wave-lengths between 0.1 and  $1.4A^2$  is

$$\mu_a = KZ^4\lambda^3 + .8Z\sigma_0 \quad (6-04)$$

<sup>1</sup>In recent papers (Phil. Mag. 1925). Barkla himself abandons the view that there exists a fluorescent *J* radiation similar to the characteristic *K* and *L* radiations. He continues, however, to find abnormalities in the absorption of soft X-rays, the nature of which is a *sudden* decrease in intensity after the rays have traversed a certain thickness of the absorbing screen. This effect is especially prominent when scattered X-rays are used, but is not always found to be present. Barkla ascribes it to a transformation of the X-rays as they traverse the matter, calling the phenomenon a "*J* transformation." His results seem to find no explanation on the basis of present theories of radiation, and an extended discussion of them would be premature.

<sup>2</sup>This is equivalent to a similar formula used by Richtmyer. (F. K. Richtmyer, Phys. Rev. 18, 13 (1921); F. K. Richtmyer and E. W. Warburton, Phys. Rev. 22, 539 (1923).) The first use of the factors  $Z^4$  and  $\lambda^3$  that I find are by Bragg and Peirce (Phil. Mag. 28, 626, 1914) and by Duane and Hunt (Phys. Rev. 6, 166, 1915) respectively. The term  $Z\sigma_0$ , representing the scattering, was employed by Barkla and Collier (Phil. Mag. 29, 995, 1912); but Hull and Rice (A. W. Hull and M. Rice, Phys. Rev. 8, 836 (1916)). Hewlett, (C. W. Hewlett, Phys. Rev. 17, 284 (1921)), and Richtmyer, loc cit., have found a term equivalent to  $.8 Z\sigma_0$  to be more satisfactory, especially at very short wave-lengths with the lighter elements. For the heavier elements a term proportional to  $Z^2$  seems to represent the scattering better than one proportional to  $Z$ , due doubtless to the cooperation in scattering by the electrons grouped in the atom as described in Chapter II. Glocker (Phys. Zeit. 19, 66, 1918) and Allen (Phys. Rev.: 27, 266, 1926) find that somewhat better agreement may be obtained if slightly different values of the exponents of  $Z$  and  $\lambda$  are used.





Here  $\lambda$  is the wave-length of the X-rays employed,  $Z$  is the atomic number of the absorber,  $K$  is a universal constant having the value  $2.24 \times 10^{-2}$  for wave-lengths shorter than the critical  $K$  absorption wave-length, if  $\lambda$  is expressed in centimeters, and a value  $.33 \times 10^{-2}$  when  $\lambda$  is between the critical  $K$  and  $L$  absorption wave-lengths. The quantity  $\sigma_0$  is given by the expression (*cf.* eq. 2.16),

$$\sigma_0 = \frac{8\pi}{3} \frac{e^4}{m^2 c^4}, \quad (6.05)$$

and has the value  $6.63 \times 10^{-25}$  cm.<sup>2</sup> It represents the total energy scattered by a single electron, when struck by a beam of unit intensity, as calculated on the classical electron theory.

The extent of the agreement of this expression (6.04) with the experimental values for the representative elements, carbon, aluminium, iron, silver and lead, is exhibited for wave-lengths between 0.1 and 1.0 Å in Fig. 88. The logarithms of the atomic absorption coefficients are plotted against the logarithms of the wave-lengths. It is remarkable that a formula with but 4 arbitrary constants is able to express so accurately the absorption by some 80 elements of radiation over so wide a range of wave-lengths. It would suggest that the relation is of some physical significance. Nevertheless, the formula is unsatisfactory for extrapolation to shorter wave-lengths, since the minimum absorption that it can give,  $0.8 Z\sigma_0$ , corresponds to a mass absorption coefficient of about .16. This is not in agreement with the mass absorption coefficient about .06 observed for all elements when hard  $\gamma$ -rays are employed.

#### 84. Owen's Law

It is natural to associate the quantities  $\tau$  and  $\sigma$  of equation (6.01) with the quantities  $KZ^4\lambda^3$  and  $.8Z\sigma_0$  respectively of equation (6.04).<sup>1</sup> In view of the manner in which the constant

<sup>1</sup> This identification is not quite justified. For as we have seen in Chapter II, the scattering is not strictly independent of the wave-length, and we shall see later (Chapter IX), that a part of the term proportional to  $Z$  represents a form of true absorption associated with the scattering process.

$K$  has been defined, it will be seen that a more complete expression of the first identity would be

$$\tau_a = (K_K Z^4 \lambda^3)_{\lambda < \lambda_K} + (K_L Z^4 \lambda^3)_{\lambda < \lambda_L} + \dots \quad (6.06)$$

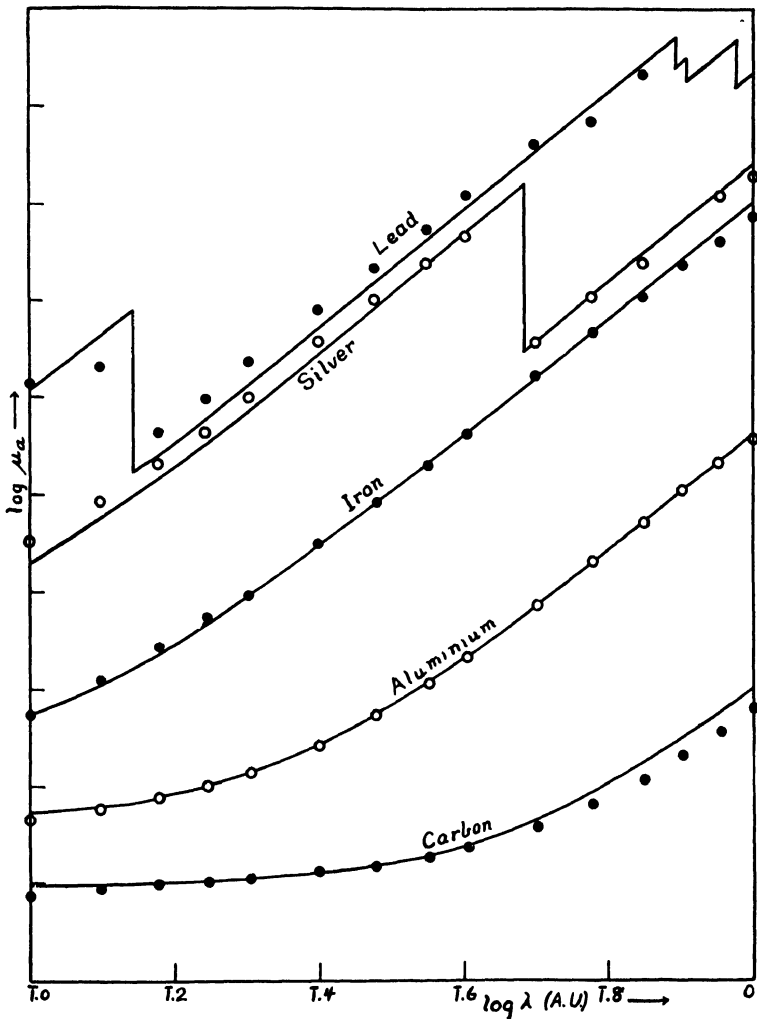

FIG. 88.

The first term of this series is to be counted, as the subscript indicates, only for wave-lengths less than the critical  $K$  absorp-

tion wave-length of the element whose atomic number is  $Z$ , and similarly for the other terms. The constant  $K_K$  has the value, according to Richtmyer and Warburton, of  $(2.24 - .33) \times 10^{-2} = 1.91 \times 10^{-2}$ . An expression equivalent to this was first given by E. A. Owen in 1918,<sup>1</sup> and it represents a more accurate statement of the absorption law which he first proposed in 1912.<sup>2</sup> I shall accordingly refer to it hereafter as Owen's law.

The first term of equation (6.06) seems to represent the absorption by the electrons in the  $K$  shell of the atom, the second term by those in the  $L$  shell, etc. If this is the case, we may write for the absorption by the  $K$  electrons in the atom,

$$\tau_K = K_K Z^4 \lambda^3, \quad (6.07)$$

remembering that  $K_K = 1.91 \times 10^{-2}$  for wave-lengths less than  $\lambda_K$ , and 0 for wave-lengths greater than  $\lambda_K$ . Also

$$\tau_L = K_L Z^4 \lambda^3, \quad (6.08)$$

where  $K_L = .25 \times 10^{-2}$ , and similarly for the absorption by the outer shells.

### 85. Absorption Due to Scattering

The empirical expression,

$$\sigma_a = .8Z\sigma_0, \quad (6.09)$$

corresponding to the second of these identities, is not in agreement with the value

$$\sigma_a = Z\sigma_0, \quad (6.10)$$

which would be anticipated from equation (2-16) for a chance distribution of the electrons within the atom. If we should calculate the atomic scattering coefficient from some such formula as (2.31), taking into account the cooperation of the electrons within the atom, we should get a result even greater than that given in equation (6.10), and therefore differing still more from the experimental value. This difficulty is obviously the same as that described above (p. 56, *et seq.*), where we

<sup>1</sup> E. A. Owen, Proc. Roy. Soc. **94**, 522 (1918).

<sup>2</sup> E. A. Owen, Proc. Roy. Soc. **86**, 434 (1912).

noticed that for short wave-lengths the experimental values of the scattering coefficient fell distinctly below those predicted by the theory. For it is only for the very short wave-lengths that the scattering accounts for any considerable part of the total absorption, so it is for these wave-lengths that the term  $.8Z\sigma_0$  of equation (6.04) is experimentally found. It is very probable that for the heavier elements and for longer waves the scattering coefficient becomes much greater than  $Z\sigma_0$ , as formula (2.31) would suggest.<sup>1</sup> The true absorption is so great under these conditions, however, that the scattered energy is very difficult to estimate.

The absorption experiments thus support the conclusion at which we had previously arrived, that the electromagnetic theory predicts too great a scattering coefficient for short wave-lengths. They supply us, however, with little information concerning the scattering coefficient for wave-lengths greater than 0.3A.

#### ELECTROMAGNETIC THEORY OF TRUE ABSORPTION

##### 86. *Pulse Theory*

An equation identical in form with expression (6.06) has been derived theoretically by the author,<sup>2</sup> making use of J. J. Thomson's old hypothesis of X-ray pulses.<sup>3</sup> Such a solution of the problem is unsatisfactory, since the basic hypothesis of X-rays consisting of short pulses is inconsistent with the fact that X-ray spectrum lines are very sharp (*cf. supra*, p. II, 14). But the fact that the Owen's empirical formula can thus be derived suggests strongly that the law may be of real physical significance. It will therefore be valuable to consider this view of the mechanism of absorption.

Thomson postulates a pulse consisting of an electric intensity  $E$  through a distance  $d$ , followed by an intensity  $-E$  for a distance  $d$ , after which the field due to the pulse vanishes. If

<sup>1</sup> Cf. e.g., S. J. M. Allen, *Phys. Rev.* **241**, (1924).

<sup>2</sup> A. H. Compton, *Phys. Rev.* **14**, 249 (1919).

<sup>3</sup> J. J. Thomson, "Conduction of Electricity through Gases," 2d Ed., pp. 326-8.

the time required for the pulse to pass is short compared with the natural period of an electron which it traverses, the acceleration of the electron during the first half of the pulse is  $Ee/m$ , its velocity at the end of the first half is  $\frac{Ee}{m} \times \frac{d}{c}$ , where  $c$  is the velocity of light, and the distance through which the particle is displaced is  $\frac{1}{2} \frac{Ee}{m} \left(\frac{d}{c}\right)^2$ . During the second half of the pulse the acceleration is  $-Ee/m$ , and when the pulse has passed the velocity of the electron is again reduced from  $Eed/mc$  to zero, though it has continued to move until its displacement is

$$x = Eed^2/mc^2. \quad (6.11)$$

If  $F$  is the restoring force on the electron when displaced a distance  $x$  from its equilibrium position, the work done in displacing the electron a distance  $x$  is

$$W = \int_0^x -Fdx. \quad (6.12)$$

But if  $\nu_0$  is the frequency of the free vibrations of the electron about its equilibrium position, the restoring force is

$$F = -4\pi^2 m \nu_0^2 \cdot x,$$

or in terms of natural wave-length instead of natural frequency,

$$F = -4\pi^2 mc^2 x / \lambda_0^2. \quad (6.13)$$

Substituting in equation (6.12) this value of  $F$  and the value of  $x$  from expression (6.11), we obtain for the work done on the electron,

$$W = \frac{2\pi^2 e^2 d^4}{mc^2 \lambda_0^2} E^2. \quad (6.14)$$

The energy per unit area of the pulse is, however,

$$\left(\frac{E^2}{8\pi} + \frac{H^2}{8\pi}\right) \cdot 2d = \frac{E^2 d}{2\pi}, \quad (6.15)$$

where  $E$  is the electric and  $H$  the magnetic intensity of the pulse, since  $E = H$ . Dividing (6.14) by (6.15) we find for the

fraction of the energy per unit area of such a pulse which is absorbed by a single electron,

$$\tau_0 = \frac{4\pi^3 e^2 d^3}{mc^2 \lambda_0^2}. \quad (6.16)$$

The absorption by the  $N_K$  electrons in the  $K$  shell should accordingly be

$$\tau_K = \frac{4\pi^3 e^2 d^3 N_K}{mc^2 \lambda_K^2}, \quad (6.17)$$

the natural wave-length of the electrons being  $\lambda_K$ . This expression is equivalent to that obtained by Thomson.

In order to associate this result with Owen's experimental law, we note that the thickness  $2d$  of the pulse corresponds closely to a complete wave-length  $\lambda$  of the incident rays. Moreover, according to Moseley's law (eq. 1.04), if we identify the natural frequency of the absorbing electrons with their critical absorption frequency, we have for the corresponding wave-lengths,  $1/\lambda_K = C_K Z^2$  approximately. According to the simplest form of Bohr's theory,  $C_K = 2\pi^2 e^4 m / n_K^2 c h^3$ , where  $h$  is Planck's constant and  $n_K$  is the quantum number of the  $K$  shell. Substituting these values for  $d$  and  $\lambda_K$  in equation (6.17) we obtain,

$$\tau_K = K_K' Z^4 \lambda^3, \quad (6.18)$$

where

$$K_K' = \frac{2\pi^7 N_K m c^{10}}{n_K^4 c^4 h^6}. \quad (6.19)$$

Making the usual assumptions that the number of electrons in the  $K$  level is  $N_K = 2$ , and that the quantum number is  $n_K = 1$ , we get  $K_K' = 10.4 \times 10^{-2}$ . This differs only by a factor of 5.4 from the experimental value  $K_K = 1.91 \times 10^{-2}$ .

It we attempt in a similar manner to calculate the absorption of a long train of waves, the result is an expression of an entirely different form and in much less satisfactory agreement with experiment. Equation (6.19) is thus dependent upon the assumption that the X-rays consist of pulses which are short compared with the natural wave-length of the absorbing elec-

trons. Since Owen's law holds for the absorption of X-ray spectrum lines, which are known to come in long trains of waves, the present theory is unsatisfactory. Nevertheless, the fact that the theoretical equation (6.19) is of just the right form, and the fact that the constant of proportionality  $K_K$  is of right order of magnitude, cannot be mere accident. Though this agreement does not justify the theory which we have developed, it gives some confidence that Owen's law is of real physical significance.

### 87. *Absorption of Long Trains of Waves*

We noted above that there is no difference in the fraction of the energy absorbed from an X-ray by a given screen before and after reflection from a crystal. After reflection from a crystal, however, even a short pulse is spread out into a long train of waves, and similarly the length of any X-ray wave train will be increased by the reflection process. This experiment therefore indicates that the length of the train of waves has little if any effect upon the fraction of the energy of the train which is absorbed on passage through matter. To simplify the problem, we shall therefore suppose that the wave trains are of infinite length, that is, that they are undamped. In order that the energy shall be removed from such a wave-train, we must suppose that it excites forced oscillations of the electrons which it traverses, and that these oscillations are in some manner damped. The work done in moving the electrons against the damping forces will then constitute the energy absorbed from the wave train.

The amount of energy thus absorbed can be estimated in the following manner. Let us suppose that at any particular absorbing electron the electric vector of the primary wave train is in the direction of the X-axis, and is expressed by  $A \cos (pt + \delta)$ , where  $p = 2\pi c/\lambda$  and  $\delta$  is the phase at the time  $t = 0$ . We shall suppose that the damping is produced by a viscous force whose magnitude is  $-rm \frac{dx}{dt}$ ,  $m$  being the

mass of the electron and  $r$  being an arbitrary constant. We shall assume also that the electron is subject to a restoring force  $-q^2mx$ . Its equation of motion is then,

$$m\frac{d^2x}{dt^2} + rm\frac{dx}{dt} + q^2mx = Ae \cos(pt + \delta). \quad (6.21)$$

The solution of this equation for the case where the wave started at a time  $t = -\infty$ , so that the system is in a steady state of oscillation, is:

$$x = -A_1 \cos(pt + \delta_1). \quad (6.22)$$

Here

$$A_1 = \frac{Ae}{mp^2} / \left\{ \left( 1 - \frac{q^2}{p^2} \right)^2 + \frac{r^2}{p^2} \right\}^{1/2},$$

and

$$\delta_1 = \delta + \tan^{-1} \left\{ \frac{r}{p} / \left( 1 - \frac{q^2}{p^2} \right) \right\}.$$

The energy dissipated in the time  $dt$  against the frictional force  $-rm\frac{dx}{dt}$  is

$$rm \frac{dx}{dt} \cdot \frac{dx}{dt} dt,$$

and the total work done on the electron as one wave traverses it is,

$$\int_0^{2\pi/p} rm \left( \frac{dx}{dt} \right)^2 dt.$$

The energy of this one wave per square centimeter per second of the wave front is, however,

$$\int_0^{2\pi/p} \left( \frac{E^2}{8\pi} + \frac{H^2}{8\pi} \right) c dt = \frac{c}{4\pi} \int_0^{2\pi/p} E^2 dt,$$

where  $E$  is the electric intensity of the wave at any instant, which is equal to the magnetic intensity  $H$ . The fraction of the

energy which is incident on unit area that is absorbed by the electron is hence,

$$\tau_e = \frac{rm \int_0^{2\pi/p} \left(\frac{dx}{dt}\right)^2 dt}{\frac{c}{4\pi} \int_0^{2\pi/p} E^2 dt} \quad (6.23)$$

Using for  $x$  the value given in equation (6.22) we find,

$$\int_0^{2\pi/p} \left(\frac{dx}{dt}\right)^2 dt = \pi A_1^2;$$

and using for  $E$  its value  $A \cos(pt + \delta)$  we obtain

$$\int_0^{2\pi/p} E^2 dt = \pi A^2/p^2.$$

Thus by (6.23) the absorption coefficient per electron becomes

$$\tau_e = \frac{4\pi r m p^2}{c} \frac{A_1^2}{A^2};$$

or substituting the value of  $A_1$  given in expression (6.22),

$$\tau_e = \frac{4\pi r e^2}{m c p^2} / \left\{ \left( 1 - \frac{q^2}{p^2} \right)^2 + \frac{r^2}{p^2} \right\}. \quad (6.24)$$

In order to put this result in a more useful form, let us evaluate the quantity

$$\int_0^\infty \frac{1}{p^3} \frac{dp}{\left( 1 - \frac{q^2}{p^2} \right)^2 + \frac{r^2}{p^2}}.$$

To do this, we assume that the damping constant  $r$  is small compared with the frequency terms  $q$  and  $p$ . This will be true unless the damping approaches its critical value. The term  $r^2/p^2$  is then small compared with  $\left( 1 - \frac{q^2}{p^2} \right)^2$  except when  $p$  is nearly equal to  $q$ . Thus for the narrow region of frequencies for which the term  $r^2/p^2$  is significant, it may be replaced by the constant term  $r^2/q^2$ . Making this substitution, the expres-

sion may be integrated, giving the value  $\pi/2r\sqrt{q^2 - r^2/4}$ . From equation (6.24), therefore,

$$\begin{aligned} \int_0^\infty \frac{\tau_e}{p} dp &= \frac{4\pi r e^2}{mc} \int_0^\infty \frac{1}{p^3} \frac{dp}{\left(1 - \frac{q^2}{p^2}\right)^2 + \frac{r^2}{p^2}} \\ &= \frac{2\pi^2 e^2}{mc\sqrt{q^2 - r^2/4}}. \end{aligned}$$

But  $\sqrt{q^2 - r^2/4} = 2\pi c/\lambda_0$ , where  $\lambda_0$  is the wave-length of the radiation emitted by the natural vibration of the electron. In terms of the wave-length our expression therefore becomes, since  $dp/p = -d\lambda/\lambda$ ,

$$\int_0^\infty \frac{\tau_e}{\lambda} d\lambda = \frac{\pi e^2}{mc^2} \lambda_0.$$

In virtue of our assumption that  $r$  is small, the absorption is practically confined to a narrow range of wave-lengths  $\delta\lambda$ . So without introducing any appreciable error we may replace the limits of integration 0 and  $\infty$  by  $\lambda_0 - \frac{1}{2}\delta\lambda$  and  $\lambda_0 + \frac{1}{2}\delta\lambda$ , respectively, where  $\lambda_0$  is the wave-length of maximum resonance. But over this narrow range,  $\lambda_0$  is nearly equal to  $\lambda$ , so to a close approximation we may write,

$$\int_{\lambda_0 - \frac{1}{2}\delta\lambda}^{\lambda_0 + \frac{1}{2}\delta\lambda} \frac{\tau_e}{\lambda^2} d\lambda = \frac{\pi e^2}{mc^2}. \quad (6.25)$$

We shall now introduce the hypothesis that the  $K$  absorption band is due to the presence of electrons whose resonance wave-lengths may lie anywhere between 0 and  $\lambda_K$ , where  $\lambda_K$  is the critical  $K$  absorption wave-length. If there is a number  $N_K$  such electrons per atom responsible for the  $K$  absorption band, it follows from equation (6.25) that

$$\int_0^{\lambda_K + \frac{1}{2}\delta\lambda} \frac{\tau_K}{\lambda^2} d\lambda = \frac{\pi e^2}{mc^2} N_K, \quad (6.26)$$

where as before  $\tau_K$  is the atomic absorption coefficient due to the  $K$  electrons. Experiment shows that the critical absorption

limit is very sharp, which means that  $\delta\lambda$  is very small compared with  $\lambda_K$ . According to the present view of absorption, this means that the damping coefficient  $r$  is very small compared with the angular frequency  $p$ , as we have assumed. Thus equation (6.26) becomes

$$\int_0^{\lambda_K} \frac{\tau_K}{\lambda^2} d\lambda = \frac{\pi e^2}{mc^2} N_K.$$

The number of electrons per atom responsible for the  $K$  absorption band is consequently

$$N_K = \frac{mc^2}{\pi e^2} \int_0^{\lambda_K} \frac{\tau_K}{\lambda^2} d\lambda. \quad (6.27)$$

A result equivalent to this has been obtained by R. A. Houstoun,<sup>1</sup> who finds on evaluating the integral from experimental data that  $N_K$  is of the order of unity. Using the data collected in Tables VI-6 and VI-7 I find by graphical integration that this equation gives in the case of Zn,  $N_K = 1.4$  electrons per atom, and for Pt,  $N_K = 4.3$  electrons per atom. These results, though of the correct order of magnitude, are not in sufficiently good accord with the accepted numbers 2 and 8 to inspire confidence in the reliability of this expression.

If we assume as an experimental datum that the absorption is proportional to the cube of the wave-length, that is,  $\tau_K = C_K \lambda^3$ , we may substitute this value of  $\tau_K$  in equation (6.27), and on integrating obtain,

$$N_K = \frac{mc^2 \lambda_K^2}{2\pi e^2} C_K, \quad (6.27a)$$

whence

$$C_K = \frac{2\pi N_K e^2}{\lambda_K^2 mc^2}. \quad (6.28)$$

Thus the part of the true atomic absorption coefficient due to the  $K$  electrons is,

$$\tau_K = \frac{2\pi e^2}{mc^2} \lambda^3 \frac{N_K}{\lambda_K^2}. \quad (6.29)$$

<sup>1</sup> R. A. Houstoun, Proc. Roy. Soc. Edinburgh, 40, 35 (1920).

Introducing similar terms representing the  $L$ ,  $M$ , etc., absorption, we obtain the absorption law:

$$\tau_a = \frac{2\pi e^2}{mc^2} \lambda^3 \left\{ \left( \frac{N_K}{\lambda_K^2} \right)_{\lambda < \lambda_K} + \left( \frac{N_L}{\lambda_L^2} \right)_{\lambda < \lambda_L} + \dots \right\}. \quad (6.30)$$

In view of Moseley's approximate relation,  $Z^2 \propto 1/\lambda_K$ , this is approximately equivalent to Owen's law, but now the formula involves only 1 arbitrary constant, the exponent of  $\lambda$ . If in equation (6.17)  $d^3$  is replaced by  $\lambda^3/8$ , it will be seen that equation (6.29) differs from the corresponding expression based on Thomson's pulse theory only by the numerical factor  $4/\pi^2$ .

### 88. *Experimental Tests*

A numerical calculation from equation (6.29) in the case of copper, using  $N_K = 2$  and  $\lambda_K = 1.38 \times 10^{-8}$  cm., gives  $\tau_K = 2.3 \times 10^{-21}$  for  $\lambda = .5A$ , whereas the experimental value is  $1.7 \times 10^{-21}$ . For the same wave-length absorbed in platinum, using  $N_L = 8$  and  $\lambda_L = 1.0 \times 10^{-8}$  cm., this equation gives  $1.8 \times 10^{-20}$  for  $\tau_L$ , whereas the experimental value is  $1.1 \times 10^{-20}$ . Though these differences are too great to ascribe to experimental error, one cannot believe that the approximate agreement is wholly accidental.

According to both expressions (6.30) and (6.17), the absorption of a definite wave-length in different elements should vary inversely as  $\lambda_K^2$ , which is only approximately proportional to  $1/Z^4$ . It is therefore important to see which of these two relations is experimentally the more precise. In Table VI-8 I have collected typical data from Tables VI-6 and VI-7 to make the test for the two wave-lengths 0.2 and 0.6A. It will be seen that the values of  $\tau_a/Z^4$  remain more nearly constant than does  $\tau_a\lambda_K^2$ , and are perhaps constant within experimental error. Thus Owen's empirical form of the absorption law, as expressed by equation (6.06), is more precise than an equation of the form (6.30) which results from the electromagnetic theory.

We shall see later (Chapter XII) that on the basis of the quantum theory Kramers has derived an approximate expres-

sion for the true absorption, according to which  $\tau_a$  is proportional to  $Z^4$  rather than to  $1/\lambda\kappa^2$ .

Thus here again, though the electron theory as based upon the usual electrodynamics helps us in interpreting the absorption of X-rays, it fails to give a strictly accurate account of the phenomenon. From the fact that the absorbed energy is spent in exciting  $\beta$  rays, which so far as we are aware is a strictly quantum phenomenon, the surprising thing is not that the classical theory fails to describe the process accurately. The wonder is that the calculations on this basis agree at all with the experiments.

TABLE VI-8

Element	$\lambda\kappa$ ( $\text{\AA}$ )	For $\lambda = 0.2A$			For $\lambda = 0.6A$		
		$\tau_a$ ( $\times 10^{23}$ )	$\tau_a/Z^4$ ( $\times 10^{28}$ )	$\tau_a\lambda\kappa^2$ ( $\times 10^{35}$ )	$\tau_a$ ( $\times 10^{23}$ )	$\tau_a/Z^4$ ( $\times 10^{27}$ )	$\tau_a\lambda\kappa^2$ ( $\times 10^{36}$ )
6 C	49.3	0.017	1.31	4.13	0.419	3.23	1.02
13 Al	7.95	0.51	1.78	3.22	13.3	4.65	.84
26 Fe	1.738	8.39	1.83	2.53	213	4.65	.65
30 Zn	1.296	17.5	2.16	2.95	399	4.93	.67
42 Mo	.618	61.5	1.97	2.35	1287	4.13	.49
50 Sn	.424	120.	1.92	2.05	.....	.....	$\tau_a\lambda L^2$
	$\lambda_L = 2.953$	.....	.....	.....	420	.67	3.67
74 W	1.119	93.3	.31	11.7	1975	.65	2.47
82 Pb	.865	154.	.34	11.5	3015	.68	2.32

## CHAPTER VII

### THE REFRACTION OF X-RAYS

#### 89. Introduction

According to the usual electron theory of dispersion, as developed originally by Drude<sup>1</sup> and Lorentz,<sup>2</sup> if the frequency  $\nu$  of the radiation transmitted by a substance is high compared with the natural frequency of the electrons in the substance, its index of refraction  $\mu$  is approximately

$$\mu = 1 - \frac{ne^2}{2\pi m \nu^2}, \quad (7.01)$$

where  $n$  is the number of electrons per unit volume, and  $e$  and  $m$  have their usual significance. This represents an index of refraction *less than unity*. Calculating  $n$  for glass of density 2.52, and using a wave-length of 1.279A, equation (7.01) predicts an index of refraction of  $1 - (5.2 \times 10^{-6})$ , which agrees within experimental error with the experimental value  $1 - (4.2 \times 10^{-6})$ , described in Chapter I.

This agreement between the calculated and the experimental values presents several points of interest. In the first place, it shows that in the region of X-ray frequencies we are able to get a quantitative test of the usual electron theory of dispersion, which is very difficult in the region of optical frequencies because of the unknown natural frequencies of the electrons composing the refracting medium. In the second place, by a comparison between the experimental and the theoretical values of the refractive index, equation (7.01) affords a means of measuring the number  $n$  of the mobile electrons per unit volume, and hence also the number per atom. This calculation is more

<sup>1</sup> Drude, "Theory of Optics," translated by Mann and Millikan, p. 388.

<sup>2</sup> H. A. Lorentz, "The Theory of Electrons," 2d Ed., p. 149.

reliable than that from the scattering of X-rays, since it is independent of the grouping of the electrons. And third, the existence of an index of refraction less than unity, implying as it does a wave motion with a velocity greater than that of light, presents an interesting problem. Of course refractive indices less than unity are found also in the optical region, as for example in the case of metals. But the calculation for the X-ray frequencies is more significant, because our knowledge of the number and relative natural frequency of the electrons effective in the refracting medium is more complete. It will therefore be of value to consider in some detail the theory of X-ray refraction.

### 90. *Calculation of the Refractive Index*

We shall base our calculation upon the fact that the index of refraction is equal to the ratio of the velocity of the wave in a vacuum to its velocity in the refracting medium, i.e., that,

$$\mu = c/v. \quad (7.02)$$

It is well known that Maxwell's equations of the electromagnetic field, when applied to a medium of permeability  $p$  and dielectric constant  $k$ , lead to a velocity of wave propagation,

$$v = c/\sqrt{pk}. \quad (7.03)$$

Here  $c$ , the ratio of the electromagnetic to the electrostatic unit of charge, is also the velocity of light in a vacuum, since in a vacuum  $p$  and  $k$  are by definition unity. When this value of  $v$  is substituted in equation (7.02), we obtain for the refractive index,

$$\mu = \sqrt{pk}.$$

For the media with which we shall deal, however, especially at the very high frequencies considered,  $p$  is very nearly unity, so we may write,

$$\mu = \sqrt{k}. \quad (7.04)$$

By the dielectric constant of a substance we mean the factor by which the capacity of a condenser is increased when the space between its conducting surfaces is filled with the substance. Thus, if the capacity of a parallel plate condenser with nothing between the plates is  $A/4\pi d$ , where  $A$  is the area of either plate and  $d$  is the distance between them, its capacity when the space is filled with a dielectric is  $kA/4\pi d$ ,  $k$  being the dielectric constant. When a potential  $V$  is applied across the condenser, the electric intensity between the plates is  $E = V/d$ , and the charge per unit area is

$$\sigma = \frac{V}{A} \cdot \frac{kA}{4\pi d} = \frac{kE}{4\pi}, \quad (7.05)$$

and

$$E = 4\pi\sigma/k. \quad (7.06)$$

Now let us suppose that the electric intensity  $E$  produces an electric polarization in the dielectric such that it possesses an electric moment  $P$  per unit volume. Thus a unit cube of the dielectric would act electrically as if it possessed a charge of  $+P$  on one face and a charge of  $-P$  on the opposite face, and there will be fictitious charges of this magnitude on the surfaces of the dielectric next to the conducting plates. If we suppose that these fictitious charges are responsible for the dielectric properties of the medium, the electric intensity between the plates of the condenser is by Coulomb's law,

$$E = 4\pi(\sigma - P),$$

since the total charge at either surface is  $(\sigma - P)$ . Combining this with equation (5.12) we get

$$P = \sigma - \frac{\sigma}{k},$$

and on substituting the value of  $\sigma$  given in equation (7.05)

$$P = \frac{E}{4\pi}(k - 1). \quad (7.07)$$

A polarization of the medium of this magnitude will therefore account for its properties as a dielectric. In terms of the polarization the dielectric constant is thus given by

$$k = 1 + 4\pi \frac{P}{E}. \quad (7.08)$$

The polarization of the medium described by equation (7.07) may result from the displacement of the electrons of which the medium is composed by the action of the electric field. Suppose there exists a group of  $n$  positive and  $n$  negative electrons in a unit volume which are so distributed that the external effect of their charges is zero. If under the action of the electric field the negative electrons are displaced a distance  $x$ , the system becomes equivalent to charges  $+ ne$  and  $- ne$  a distance  $x$  apart. The resulting polarization of the medium is hence

$$P = nex. \quad (7.09)$$

In the case under consideration, the displacements  $x$  of the electrons are the forced oscillations of electrons due to the electromagnetic wave which traverses the medium. We showed in the last chapter (eq. 6.22), that if the natural frequency of oscillation of an electron is  $\nu_0 = q/2\pi$ , and if the damping is negligible, the electron's displacement is

$$x = \frac{Ae \cos pt}{m(q^2 - p^2)}. \quad (7.10)$$

Here  $A \cos pt = E$ ,  $E$  being the electric intensity of the wave traversing the electron, and having the frequency  $\nu = p/2\pi$ . Thus,

$$x = \frac{Ee}{4\pi^2 m(\nu_0^2 - \nu^2)}. \quad (7.11)$$

It will be seen that the displacement of the electron may be in either the same direction or the opposite direction to the applied field, according as the natural frequency of the electron is greater than or less than the frequency of the impressed field.

If there are  $n$ , electrons per unit volume whose natural fre-

quency is  $\nu_s$ , the polarization to which they give rise is  $P_s = n_s e x_s$ ; and if there are electrons of  $N$  different natural frequencies, the total polarization is

$$\begin{aligned}
 P &= \sum_1^N P_s = \sum_1^N n_s e x_s \\
 &= \frac{E e^2}{4\pi^2 m} \sum_1^N \frac{n_s}{(\nu_s^2 - \nu^2)}.
 \end{aligned}
 \tag{7.12}$$

The dielectric constant for the frequency  $\nu$  is thus, by equation (7.08)

$$k = 1 + \frac{e^2}{\pi m} \sum_1^N \frac{n_s}{(\nu_s^2 - \nu^2)},
 \tag{7.13}$$

and from equation (7.04) the refractive index is given by

$$\mu^2 = 1 + \frac{e^2}{\pi m} \sum_1^N \frac{n_s}{(\nu_s^2 - \nu^2)}.
 \tag{7.14}$$

This expression is the equivalent of Sellmeier's dispersion formula, which has been found to account in a fairly satisfactory manner for the optical dispersion of many substances.

We have assumed in our derivation of equation (7.14) that the force on any electron in the dielectric is equal to  $Ee$ , where  $E$  is externally applied field. It is clear that the force on an electric charge within a dielectric is not the same as if the dielectric were not present, because of the displacement of the electrons of which the dielectric is composed. The forces due to the dielectric have been considered carefully by Lorentz.<sup>1</sup> Since in the case of frequencies corresponding to X-rays the dielectric constant differs from unity only by about  $10^{-6}$ , the correction due to these forces is however negligible for our present purpose.

In view of the fact that  $\mu$  is very nearly equal to unity in the case of X-rays, equation (7.14) may be written to a very close approximation,

$$\mu = 1 + \frac{e^2}{2\pi m} \sum_1^N \frac{n_s}{(\nu_s^2 - \nu^2)}.
 \tag{7.15}$$

<sup>1</sup>H. A. Lorentz, "The Theory of Electrons," p. 137 (1916).

This expression, when summed for the different types of electrons in the refracting material, should describe to a very close approximation the index of refraction of the medium for X-rays. For many of the ordinary refracting media, such as glass, rock-salt, etc., there presumably exist no electrons whose natural frequencies are comparable with the frequency of ordinary X-rays, i.e., for all the refracting electrons,  $\nu_s^2 \ll \nu^2$ . In this case (7.15) may be written

$$\mu = 1 - ne^2/2\pi m \nu^2, \quad (7.16)$$

where  $n = \sum_1^N n_s$  is the total number of mobile electrons per unit volume. This is identical with our equation (7.01), which we saw was in close agreement with experiment. If it is supposed that the natural frequency of the  $K$  electrons in the atom is equal to the critical  $K$  frequency, and similarly for the electrons in the other energy levels, calculation shows that the values predicted by equation (7.15) do not differ much from those calculated from (7.16) except in the immediate neighborhood of a critical frequency.

### 91. *Significance of a Refractive Index Less than Unity*

It is a well-known corollary of the special theory of relativity that no signal can be transmitted with a velocity greater than that of light in a vacuum. We have seen, however, that the index of refraction of most substances (probably every substance) for X-rays is less than unity, which according to our fundamental equation (7.02) means a velocity in the medium greater than  $c$ . This result follows directly from equation (7.13), according to which the dielectric constant is less than unity for frequencies greater than the natural frequencies of the electrons in the medium. It is the fact that in this case the displacements of the electrons composing the medium are opposite in direction to the displacing force (eq. 7.11) which makes  $k < 1$  and hence  $v > c$ .

That the displacements of the electrons should be opposite in direction to the force producing the displacement is at first

thought surprising. A mechanical analogy would be the application to a pendulum of a periodic force of frequency greater than the natural frequency of the pendulum. If this is done, applying the force for example with the fingers, one readily verifies the prediction that the displacement is opposite to the applied force when  $\nu > \nu_0$ . One notices, however, that the first impulse imparted to the pendulum displaces it in the direction of the applied force; it is only for later impulses that the displacement is in the opposite direction.

Similarly if we solve the differential equation (6.21) for an applied force  $Ae \cos pt$  beginning at the time  $t = 0$  instead of  $t = -\infty$  as assumed in equation (6.22), we find that the initial displacement of the electron is in the direction of the electric force.

This result means that for the first wave in the train,  $k$  is always greater than 1, and hence  $v < c$ ; but for the subsequent waves  $k < 1$  if  $\nu > \nu_0$ . It follows that the wave front necessarily is propagated through the medium with a velocity less than that of light in free space. If the following waves travel faster, they must vanish when they reach the front of the wave train. Thus while the individual waves may have a velocity greater than  $c$ , the group of waves, being limited by the front of the train, always goes with velocity  $\geq c$ . Our result is therefore consistent with the statement that a signal cannot be transmitted with a velocity greater than  $c$ .

A familiar example of the distinction between wave velocity and group velocity is that of the waves produced at the bow of a boat moving through the water. In this case one can see the individual waves, which move faster than the train, form at the rear of the train, move gradually to the head of the train, and then disappear.

## 92. Deviations from Bragg's Law

Since the index of refraction differs from unity, when X-rays enter a crystal the wave front is altered in direction and the wave-length is changed. If within the crystal  $\lambda'$  is the wave-

length and  $\theta'$  is the glancing angle of incidence on the atomic layers, we have, as in equation (1.03), that

$$n\lambda' = 2D \sin \theta'. \quad (7.17)$$

But by definition,

$$\mu = \cos \theta / \cos \theta',$$

whence

$$\sin \theta' = \frac{1}{\mu} \sin \theta \left( 1 - \frac{1 - \mu}{\sin^2 \theta} \right),$$

to the first power of  $1 - \mu$ . Noting also that  $\lambda/\lambda' = \mu$ , equation (7.17) becomes <sup>1</sup>

$$n\lambda = 2D \sin \theta \left( 1 - \frac{1 - \mu}{\sin^2 \theta} \right). \quad (7.18)$$

The wave-lengths calculated from this expression differ from those given by Bragg's law (1.03) by about 1 part in 10,000.

If the crystal is composed only of electrons whose natural frequencies are considerably less than that of the incident X-rays, as is the case for rock-salt and calcite if  $\lambda < 1.5\text{A}$ , we may use from equation (7.16),

$$1 - \mu = \frac{se^2}{2\pi m v^2} = \frac{se^2 \lambda^2}{2\pi m c^2},$$

writing  $s$  instead of  $n$  as the number of electrons per unit volume to avoid confusion. But to a close approximation  $\sin \theta = n\lambda/2D$ , whence

$$\frac{1 - \mu}{\sin^2 \theta} = \frac{2se^2 D^2}{\pi n^2 m c^2} \equiv \frac{b}{n^2}. \quad (7.19)$$

Thus for a given crystal the correction to Bragg's law indicated by equation (7.18) can be effected by merely multiplying the grating space by the factor  $(1 - b/n^2)$ , that is

$$n\lambda = 2D \sin \theta \left( 1 - \frac{b}{n^2} \right). \quad (7.20)$$

For rock-salt  $b = 9.6 \times 10^{-5}$ , and for calcite  $b = 1.46 \times 10^{-4}$ .

<sup>1</sup> An expression equivalent to this was first given by C. G. Darwin, *Phil. Mag.* 27, 318 (1914). See also P. Ewald, *Phys. Zcits.* 21, 617 (1920).

In order to determine the refractive index from such measurements, it is necessary to determine the apparent wavelength in two different orders. It then follows from equation (7.18) that

$$1 - \mu = \frac{\lambda_1 - \lambda_2}{\lambda_2} \cdot \frac{n_2^2}{n_2^2 - n_1^2} \sin^2 \theta, \quad (7.21)$$

where  $n_1 \lambda_1 = 2D \sin \theta_1$ , etc.,  $\theta_1$  being the observed glancing angle for order  $n_1$ .

We have already noticed (p. 35) how Stenstrom, using a vacuum spectrometer, first discovered the refraction of soft X-rays by observing differences in the apparent wavelength as measured in different orders, and how his results were confirmed in the region of ordinary X-rays by Duane and Patterson and by Siegbahn. Thus as an example, Duane and Patterson<sup>1</sup> found for the  $L_1$  line of tungsten,

$$\begin{aligned} \lambda_1 - \lambda_2 &= .00015 \text{ \AA}, & n_1 &= 1, & \theta_1 &= 14^\circ 5', \\ \lambda_2 &= 1.473 \text{ \AA}, & n_2 &= 2, \end{aligned}$$

from which, by (7.21),  $1 - \mu = 8 \times 10^{-6}$ . Similarly for the  $\beta_1$  and  $\gamma_1$  lines the index of refraction resulting from their observations is compared in Table VII-1 with that calculated from equation (7.16).

TABLE VII-1

REFRACTIVE INDEX BY DEVIATIONS FROM BRAGG'S LAW IN CALCITE

Line	$\lambda$	$1 - \mu$ (expt.)	$1 - \mu$ (theory)
<i>W</i> $L\alpha_1$	1.473 $\text{\AA}$	$8 \times 10^{-6}$	$8 \times 10^{-6}$
<i>W</i> $L\beta_1$	1.279	10	6
<i>W</i> $L\gamma_1$	1.096	3	4.5

Results of a similar character, but of higher precision have been secured by Hjalmar.<sup>2</sup>

<sup>1</sup> W. Duane and R. A. Patterson, *Phys. Rev.* **16**, 532 (1920).

<sup>2</sup> Hjalmar, *The Spectroscopy of X-rays*, Siegbahn (1925), p. 22.

93. *Use of the Crystal Wedge*

A modification of this method, which has given precise measurements of X-ray refractive indices, has been introduced by Davis.<sup>1</sup> This method consists in grinding and polishing the crystal under examination at such an angle that the ray which is reflected in the first order enters the crystal surface at a very small grazing angle. The result is that when the X-rays strike the crystal at the acute angle the beam is considerably deflected, through almost 3 minutes of arc in one experiment.

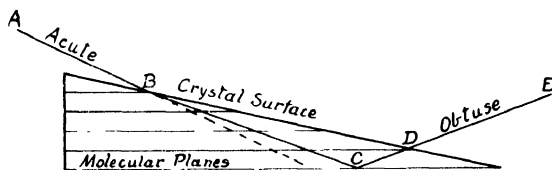

FIG. 89.

The determinations of the refractive index made by von Nardroff<sup>2</sup> and Hatley<sup>3</sup> using this method are included in Table VII-2. The values in the third column of this table are calculated from equation (7.15), which in the case of iron pyrites and the copper *K* lines differs measurably from equation (7.16). Von Nardroff finds the most satisfactory agreement with his experimental values when the calculation is made for 2 electrons in the *K* group, assuming that their natural frequency is that of the *K* absorption limit.

Strong evidence that the effective natural frequencies of the electrons are identical with the critical absorption frequencies is afforded by Hjalmar and Siegbahn's recent observation<sup>4</sup> of anomalous dispersion of X-rays. They made a careful comparison of the apparent lattice constants of calcite and gypsum for different wave-lengths. The measurements are shown

<sup>1</sup> B. Davis and C. C. Hatley, *Phys. Rev.* **23**, 290 (1924). B. Davis and R. von Nardroff, *Phys. Rev.* **23**, 291 (1924).

<sup>2</sup> R. von Nardroff, *Phys. Rev.* **24**, 149 (1924).

<sup>3</sup> C. C. Hatley, *Phys. Rev.* **24**, 486 (1924).

<sup>4</sup> E. Hjalmar and M. Siegbahn, *Nature*, **115**, 85 (1925).

graphically in Fig. 90, where values of  $D_1/D_2 = \sin \theta_2/\sin \theta_1$  are plotted against the wave-lengths. It will be seen that there are in the curve two marked discontinuities, which coincide at least very nearly with the wave-lengths of the absorption edges of calcium and sulphur.

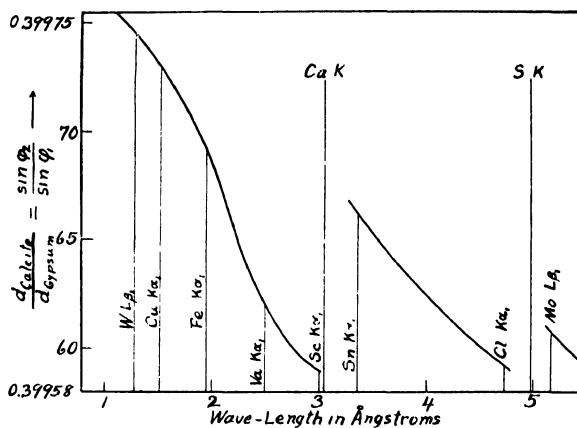

FIG. 90.

The form of the curve is similar to that anticipated from equation (7.15), showing, as the theory predicts, an abrupt variation as a natural frequency is passed.

#### 94. Total Reflection of X-rays<sup>1</sup>

Since the index of refraction is less than unity, if the X-rays strike a polished surface at a sufficiently large angle of incidence they should be totally reflected. A description of this phenomenon has been given in Chapter I (p. I, 40). A series of photographs showing this total reflection and the critical angle of various substances for  $\lambda 0.808\text{\AA}$ , very kindly made by Dr. R. L. Doan for this illustration, is shown in Fig. 91. From the sharpness of the critical angles shown in this figure, it is evident that

<sup>1</sup> A. H. Compton, Bulletin Nat. Res. Council No. 20, p. 48 (1922); Phil. Mag. 45, 1121 (1923). B. Davis and H. M. Terrill, Nat. Acad. Sci. 8, 357 (1922). M. Siegbahn, Tysisk. Tidskr. 21, 170 (1923). P. Kirkpatrick, Nature, 113, 98 (1924). H. E. Stauss, Nature, 114, 88 (1924). N. Carrara, N. Cimento, 1, 107 (1924).

a precise determination of refractive index can thus be made. From this photograph,  $\theta_c$ , the critical glancing angle, is  $10' 38''$  for  $\lambda .708\text{\AA}$  reflected from speculum metal and since from equation (I. 12),

$$1 - \mu = \frac{1}{2}\theta_c^2, \quad (7.22)$$

we have

$$1 - \mu = 4.77 \times 10^{-6},$$

with an error which is probably less than 1 per cent.

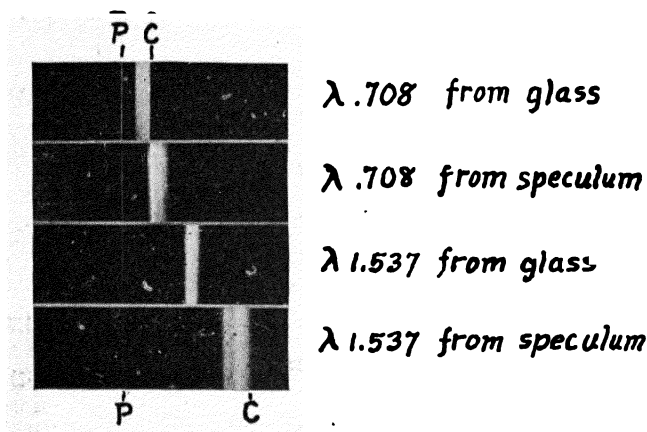

FIG. 91.

Combining equations (7.22) and (7.16), we find that

$$\theta_c = \frac{e}{\pi^{\frac{1}{2}} m^{\frac{1}{2}} c} s^{\frac{1}{2}} \lambda. \quad (7.23)$$

That is, since  $s$  is nearly proportional to the density, the critical angle is approximately proportional to the wave-length, and to the square root of the density of the reflecting material.

The specular character of the reflection is illustrated by the sharp line due to the reflected ray in Fig. 93, which is totally reflected from a glass surface. In some total reflection measurements using a piece of plate glass, however, the reflected beam was found to be diffuse. Apparently both the sharpness and the intensity of the reflected image depends upon having a well

polished surface. When such a surface is used, 80 or 90 per cent of the rays incident within the critical angle are reflected.

### 95. *Refraction by Means of a Prism*

The earliest attempts to measure the index of refraction of X-rays were by passing the rays through prisms. Not only Roentgen, but many later experimenters<sup>1</sup> have failed by this

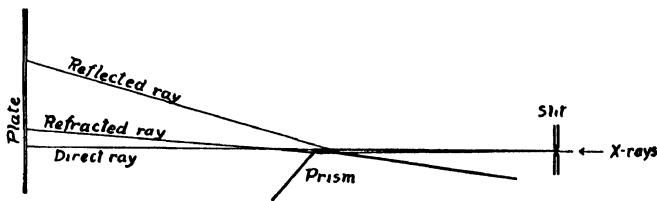

FIG. 92.

method to detect any deviation of the rays traversing the crystal. Recently, however, Larsson, Siegbahn and Waller<sup>2</sup> have succeeded not only in deviating an X-ray beam, but also in obtaining a dispersion spectrum of X-rays. The details of their arrangement are shown diagrammatically in Fig. 92, and one of the resulting photographs is shown in Fig. 93. Their success was due to the fact that their X-rays struck the face of the prism at a fine glancing angle, just greater than the critical angle for the rays which are refracted, whereas most of the former experiments had been done with the crystal set for minimum deviation.

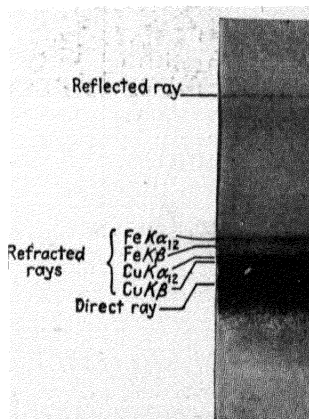

FIG. 93.—Prism spectrum of X-rays. (Siegbahn, Larsson and Walker.)

<sup>1</sup> W. C. Roentgen, *Ann. d. Phys.* **64**, 1 (1898). B. Walter, *Naturw. Rundschau*, **11**, 332 (1896). G. Gouy, *Comptes Rendus*, **122**, 1196 (1896); **123**, 43 (1896). J. C. Chapman, *Proc. Camb. Phil. Soc.* **16**, 574 (1912). C. G. Barkla, *Phil. Mag.* **31**, 257 (1916). D. L. Webster and H. Clark, *Phys. Rev.* **8**, 528 (1916).

<sup>2</sup> A. Larsson, M. Siegbahn and I. Waller, *Naturwiss.* **52**, 1212 (1924).

96. *Table of Refractive Indices for X-rays*

A summary of the determinations of the index of refraction for X-rays which have been made by various methods is given in the following table:

TABLE VII-2  
INDICES OF REFRACTION FOR X-RAYS

$\lambda$	Substance	$1 - \mu(\text{th})^*$ $\times 10^6$	$1 - \mu(\text{expt})$ $\times 10^6$	Observer	Method
.52A	Glass	.9	.9	Compton	Total reflection
.631	Glass	1 43	1.22 $\pm$ .15	L. S. & W. †	Prism
.631	Iron pyrites	2 64	2 87 $\pm$ .20	von Nardroff	Crystal wedge
.708	Glass	1 73	1 64 $\pm$ .10	L. S. & W.	Prism
.708	Calcite	1 84	2 03 $\pm$ .09	Hatley	Crystal wedge
.708	Iron pyrites	3 31	3 35 $\pm$ .20	von Nardroff	Crystal wedge
.708	Speculum metal	4 90	4 77 $\pm$ .04	Doan	Total reflection
1.279	Glass	5 2	4 2	Compton	Total reflection
1.279	Silver	19 8	21 5	Compton	Total reflection
1.389	Glass	6 65	6.65 $\pm$ .05	L. S. & W.	Prism
1.389	Iron pyrites	13 53	13 2 $\pm$ 4	von Nardroff	Crystal wedge
1.538	Glass	8 14	8 12 $\pm$ .05	L. S. & W.	Prism
1.538	Iron pyrites	17 60	17 6 $\pm$ 5	von Nardroff	Crystal wedge
1.750	Glass	10 5	10 0 $\pm$ 4	L. S. & W.	Prism
1.933	Glass	12 8	12 4 $\pm$ .4	L. S. & W.	Prism

\* The calculation is by eq. (7 16) in every case except for silver and iron pyrites, for which eq. 7 15 is used.

The density of the glass is 2.55.

† L. S. & W. = Larsson, Siegbahn and Waller.

97. *Significance of the Values of the Refractive Index*

It is interesting that in no case does the experimental value of the index of refraction differ from the theoretical value by more than may well be experimental error. This quantitative confirmation of the dispersion formula carries with it important consequences. In the first place, whatever faults the classical wave theory of radiation may have as applied to other problems which we have considered, it appears to give reliable results when applied to the problem of refraction. In view of its partial

failure in the closely related problems of scattering and absorption of X-rays, this result is significant, and must serve as a valuable guide in the development of a complete theory of radiation.

In the second place, we find evidence that there is a definite natural frequency associated with the electrons in the inner electronic rings, and that this frequency is that of the critical absorption limit. It was not at all obvious that this natural frequency should not be that of, for example, the  $K\alpha$  line. The result is, however, in accord with the fact that the absorption has a sharp discontinuity at this wave-length. There is, however, this difference: Measurements such as the recent ones of Richtmyer<sup>1</sup> show that the absorption limit is exceedingly sharp. But experiments by Davis and Slack,<sup>2</sup> using Siegbahn's prism method, show that the refractive index changes by no means so abruptly at this wave-length. For incident frequencies so near the critical absorption frequency that equation (7.15) would indicate  $\mu > 1$ , experiment shows (CuK  $\beta$  line traversing a copper prism)  $\mu < 1$  as usual. Thus the indications are that the branches of the dispersion curve are rounded off and do not approach infinity.

Finally, these measurements afford us with our most direct and accurate method of counting the number of mobile electrons in atoms. In calculating the theoretical value of the index of refraction we have assumed that the number of electrons per atom is equal to the atomic number. From the precision with which the index as thus calculated agrees with the experiments, it follows that this assumption is probably correct to within less than 1 per cent.

The other two most direct methods of counting the number of electrons in the outer part of the atom are the study of the scattering of alpha particles by atomic nuclei and the measurement of the intensity of scattered X-rays. It is not obvious from first principles that the alpha particle method will measure a charge identical with that of the mobile electrons; this will

<sup>1</sup> F. K. Richtmyer, *Phys. Rev.* **26**, 724 (1925).

<sup>2</sup> B. Davis and C. M. Slack, *Phys. Rev.* **25**, 881 (1925).

depend upon how far into the atom the alpha particle penetrates. The intensity of the scattered X-rays, on the other hand, though determined by the electrons exterior to the nucleus, is a function not only of their number but also of their arrangement. The index of refraction is theoretically independent of the grouping of the electrons, and depends upon their resonance only to the same extent as does the scattering. It is accordingly gratifying that the estimate from refraction measurements also indicates that the number of electrons per atom which are affected by high frequency radiations is equal to the atomic number.

Not only can we thus count the total number of electrons, we are also afforded a means of determining the number of electrons associated with the various electron shells. For the magnitude of the resonance effects observed, when the incident frequency is near the natural frequency of some electrons in the mirror, depends upon the number of electrons per atom with this natural frequency. On this basis, as we have seen, von Nardroff has obtained good evidence that there are 2 electrons in the *K* shell of iron. It seems reasonable to hope the further studies of this character will give us direct information also regarding the number of electrons in the various *L* and *M* levels.

## X-RAYS AND QUANTUM THEORY

### CHAPTER VIII

#### THE PHOTOELECTRIC EFFECT WITH X-RAYS

##### 98. *The Origin of the Quantum Theory*

The quantum theory had its origin in an effort to account for the radiation by black bodies. At the beginning of the present century it was recognized that great difficulties stood in the way of any satisfactory explanation of the radiation from hot bodies according to the usual electromagnetic theory. Lord Kelvin spoke of this problem as being one of the dense clouds on the horizon of the Physics of that day. It was at about this time that Planck proposed the bold view that electromagnetic radiation is not emitted or absorbed continuously, but rather in units. He succeeded in showing that, if this unit was taken to have an energy proportional to the frequency of the radiation, an expression could be obtained which represented very accurately the experimental value of the intensity of hot body radiation. On the other hand, more extended investigations of the matter from the standpoint of the classical electrodynamics by Lord Rayleigh, Poincare and J. H. Jeans served to show only more clearly that the older theory was inadequate to account for the phenomenon.

##### 99. *Planck's Quantum Hypothesis*

In the hands of Planck the quantum hypothesis has taken various forms. At first he assumed that radiant energy was both absorbed and emitted in integral multiples of  $h\nu$ , where  $\nu$  is the frequency of the radiation and  $h$  is a universal constant now known as Planck's constant. He later showed that the same radiation formula could be derived if it was supposed that radia-

tion was absorbed continuously, if only the radiated energy occurred in quanta magnitude  $h\nu$ . Other writers have postulated mechanisms of one form or another which permit absorption in a continuous manner by means of oscillators until the energy of the oscillator is  $h\nu$ , when radiation may begin. In this way a formal reconciliation between the requirements of heat radiation and classical electrodynamics seems to be possible. Recognizing, however, that some form of discontinuity must be present, there has been a strong feeling, stimulated by Einstein, that a simpler and more satisfactory form of the quantum postulate is that energy must always occur in bundles or quanta of magnitude  $h\nu$ .<sup>1</sup>

As a consequence of this view, Einstein suggested that the atoms in a solid, oscillating as they do with definite natural frequencies about their equilibrium positions, should have thermal energy which is an integral multiple of  $h$  times their natural frequency. He showed from this assumption that the specific heat of solids at low temperatures should approach zero—a conclusion contrary to that of the classical kinetic theory, which predicts unchanged specific heat as the temperature falls. This conclusion was in good accord with experiments by Nernst and others, which showed that as the absolute zero of temperature is approached the specific heat of all solids rapidly approaches zero.

The complexity of the problems of hot body radiation and of specific heat is such that it was difficult to prove through them the necessity for introducing the quantum concept. For this reason, though no adequate solutions of these problems were forthcoming on the basis of the older dynamics, many physicists remained unconvinced as to the necessity of the quantum hypothesis.

#### 100. *Einstein's Suggestion of Radiation Quanta*

The physical existence of quanta of energy may be said to have been established by studies of the photoelectric effect. In

<sup>1</sup> A more general formulation of the quantum postulate is given in Chapter X.

accord with his view that energy must always exhibit itself in quanta, Einstein suggested the possibility that radiation may consist of discrete bundles of energy of amount  $h\nu$ , and that photoelectrons are produced when such radiation quanta, or "light darts" are absorbed by matter. From this hypothesis he predicted<sup>1</sup> that the kinetic energy with which photoelectrons are ejected from a metal by light, when corrected for the energy required to remove the electron from the metal, should be given by the expression,

$$\frac{1}{2}mv^2 = h\nu - w_0, \quad (8.01)$$

where  $w_0$  is the energy necessary to remove the electron, and  $h$  is again Planck's constant. It was seven years before experiments by Richardson and Compton<sup>2</sup> and by Hughes<sup>3</sup> showed that the energy of the emitted electrons was indeed proportional to the frequency less a constant, and that the factor of proportionality was close to the value of  $h$  calculated from Planck's radiation formula. Following this work came in rapid succession Bohr's remarkably successful quantum theory<sup>4</sup> of the spectrum of hydrogen, the discovery by Duane and Hunt<sup>5</sup> and others (p. 27) that the continuous X-ray spectrum has a sharp upper limit given accurately by

$$h\nu_{\max} = eV, \quad (8.02)$$

where  $V$  is the potential applied to the X-ray tube, and Millikan's precise determination of  $h$  from photoelectric experiments with the alkali metals.<sup>6</sup> That the constant  $h$  has a definite physical significance could no longer be denied.

The question confronting us is no longer the justification of the quantum postulate, but rather what is the relation of the quantum to the usual concepts of dynamics and electrodynamics. This question we are as yet unable to answer com-

<sup>1</sup> A. Einstein, *Ann. d. Phys.* **17**, 145 (1905).

<sup>2</sup> O. W. Richardson and K. T. Compton, *Phil. Mag.* **24**, 575 (1912).

<sup>3</sup> A. L. Hughes, *Phil. Trans. A.* **212**, 205 (1912).

<sup>4</sup> N. Bohr, 1913 (cf. p. I 30).

<sup>5</sup> W. Duane and F. L. Hunt, *Phys. Rev.* **6**, 166 (1915) (cf. p. 27).

<sup>6</sup> R. A. Millikan, *Phys. Rev.* **7**, 18 and 355 (1916).

pletely; but progress towards its solution may be made by studying the application of the quantum point of view to specific problems. Before reconsidering from this standpoint the problems which have been treated in earlier chapters on the basis of the classical theory, let us look into the properties of the photoelectrons ejected by X-rays, whose very existence is an anomaly when we consider X-rays as electromagnetic waves.

### 101. *Beta Rays Excited by X-rays*

It was observed by Perrin <sup>1</sup> and by Curie and Sagnac,<sup>2</sup> early in the history of X-rays, that when these rays fall on solid screens a type of secondary radiation is emitted which is nearly completely absorbed in 1 mm. of air. Dorn <sup>3</sup> showed that this radiation consisted of negatively charged corpuscles which could be deflected by a magnetic field; and assuming the same ratio of  $e/m$  as that of the cathode rays, he found that the velocities of these secondary particles were of the order of  $\frac{1}{10}$ th the velocity of light. We shall call these high speed electrons "beta rays" or "beta particles."

### 102. *Methods of Experimental Investigation*

The presence of beta rays can be detected by allowing X-rays to fall on a plate insulated in a good vacuum. The plate is then found to acquire a positive charge, due to the emission of the secondary electrons. The effect is thus strictly analogous to the photoelectric effect observed with light.

A second method of investigation is to make use of the ionization produced by the beta rays. Thus, it is found that if X-rays strike a solid substance placed in a gas, the ionization in the neighborhood of the solid is much more intense than that elsewhere in the gas. The region of intense ionization, being determined by the range of the beta rays, may

<sup>1</sup> Perrin, *Ann. de Chim. et Phys.* (7), vol. 2, p. 496 (1897).

<sup>2</sup> Curie and Sagnac, *Jour. de Phys.* (4), vol. 1, p. 13 (1902).

<sup>3</sup> Dorn, "Lorentz Jubilee Volume," p. 595 (1900).

be varied by changing the pressure of the gas. Thus, since the ionization due to the absorption of the X-rays in the gas is proportional to the pressure  $P$ , the total ionization  $I$ , if the second electrons are completely absorbed, is given by

$$I = CP + I_c,$$

where the constant of proportionality  $C$  can be determined by experiment, and  $I_c$  represents the ionization due to the photoelectrons from the solid. Thus

$$I_c = I - CP. \quad (8.03)$$

Theoretically this method is open to the objection that it does not distinguish between photoelectrons and secondary X-radiation of very soft type. Under ordinary conditions, however, the ionization due to the electrons is so much greater than that due to the very soft secondary X-rays that no confusion is apt to arise. This method is a convenient one, and has been much used.

In many respects the most satisfactory method of studying these secondary beta rays is the beautiful one devised by C. T. R. Wilson,<sup>1</sup> in which the tracks of the individual particles are rendered visible by condensing water droplets on the ions formed along their paths. By this means it is possible to count accurately the number of secondary electrons emitted, study their distribution, and make measurements of their range in air. If two simultaneous photographs are taken at right angles with each other, by the method described by Shimizu,<sup>2</sup> the exact shape and total length of the paths may also be determined.

A very useful method of counting the number of beta rays has been developed by Geiger<sup>3</sup> and others.<sup>4</sup> This device consists of a needle point which is surrounded by a conducting

<sup>1</sup> C. T. R. Wilson, Proc. Roy. Soc. **87**, 277 (1912).

<sup>2</sup> T. Shimizu, Proc. Roy. Soc. **90**, 425 (1921).

<sup>3</sup> H. Geiger, Verh. d. D. Phys. Ges. **15**, 534 (1913).

<sup>4</sup> A. F. Kovarik and L. W. McKeenan, Phys. Zeitschr. **15**, 434 (1914); Phys. Rev. **6**, 426, 1915; **8**, 574 (1916). A. F. Kovarik, Phys. Rev. **13**, 272 (1919). W. Bothe and H. Geiger, Zeits f. Phys. **32**, 639 (1925) *et al.*

envelope at about + 1800 volts or - 2400 volts (in air). When a beta particle traverses the enclosed air, producing ions, a sudden surge of current passes through the chamber, which is large enough to detect directly with a string electrometer, or to amplify by means of three electrode tubes.

For investigating the velocities of the beta rays excited by X-rays, the method of photographing their magnetic spectrum has given the best results. For this purpose, the arrangement employed first by Robinson and Rawlinson <sup>1</sup> is very satisfactory. This arrangement is illustrated in Fig. 94.

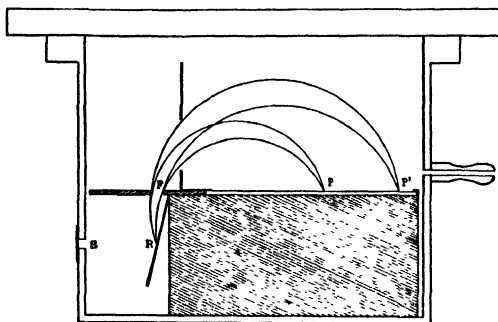

FIG. 94.

A flat, air-tight, brass box having a window  $S$  for the admission of the primary X-rays, is evacuated and placed between the poles of a large electromagnet. Secondary electrons from the radiator  $R$  go out in all directions, and those passing through the slit  $F$  have their paths bent around by the magnetic field to some point  $P$  on a photographic plate. The geometrical arrangement is such that all electrons emitted with the same speed from a certain point on  $R$ , and passing through the slit  $F$  will fall on the same line at  $P$ . From the position of this line the radius of curvature can be determined, and the velocity  $v$  of the electrons responsible for the line may be calculated from the formula,

$$v = RH \frac{e}{m}, \quad (8.04)$$

<sup>1</sup> Robinson and Rawlinson, *Phil. Mag.* 28, 277 (1914).

where  $R$  is the radius of curvature,  $H$  is the effective strength of the magnetic field, and  $e$  and  $m$  have their usual significance.

### 103. *Photoelectrons and Recoil Electrons*

When a study of the beta particles is made by the cloud expansion method, it is found that X-rays of a given frequency eject particles of two types, easily distinguishable from each other by the fact that the range of one type is much greater than that of the other.<sup>1</sup> Examples of these two types of beta rays are shown in Figs. 95, 96, and 97. In Fig. 95 there appear 4 long tracks of the first type, and also, originating in the path of the primary beam, 3 tracks of the second type which are so short that they appear as spheres. In obtaining Fig. 96, X-rays of somewhat shorter wave-length were used, so that both types of tracks are longer, some of those of the shorter type now being of measurable length. When X-rays of yet shorter wave-length are used, as in Fig. 97, the tracks of the second type rapidly increase in length, and greatly outnumber the longer ones.

Measurements of the range in air show<sup>2</sup> that the tracks of the longer type are produced by electrons ejected with an energy only slightly less than the quantum  $h\nu$ , as is to be expected according to Einstein's photoelectric equation (8.01). It is thus highly probable that their mode of origin is identical with that of the photoelectrons ejected from alkali metals by light. These long range particles are accordingly called *photoelectrons*, whether ejected by light, X-rays or  $\gamma$ -rays.

The lengths of the shorter tracks produced by X-rays correspond to electrons having energies usually less than 10 per cent of a whole quantum  $h\nu$ , so that they must originate in a different manner from the photoelectrons. It is found<sup>3</sup> that the number of these short beta rays is approximately equal to

<sup>1</sup> C. T. R. Wilson, Proc. Roy. Soc. 104, 1 (1923). W. Bothe, Zeits. f. Physik, 16, 319 (1923); 20, 237 (1923).

<sup>2</sup> C. T. R. Wilson, loc. cit.

<sup>3</sup> A. H. Compton and A. W. Simon, Phys. Rev. 25, 306 (1925).

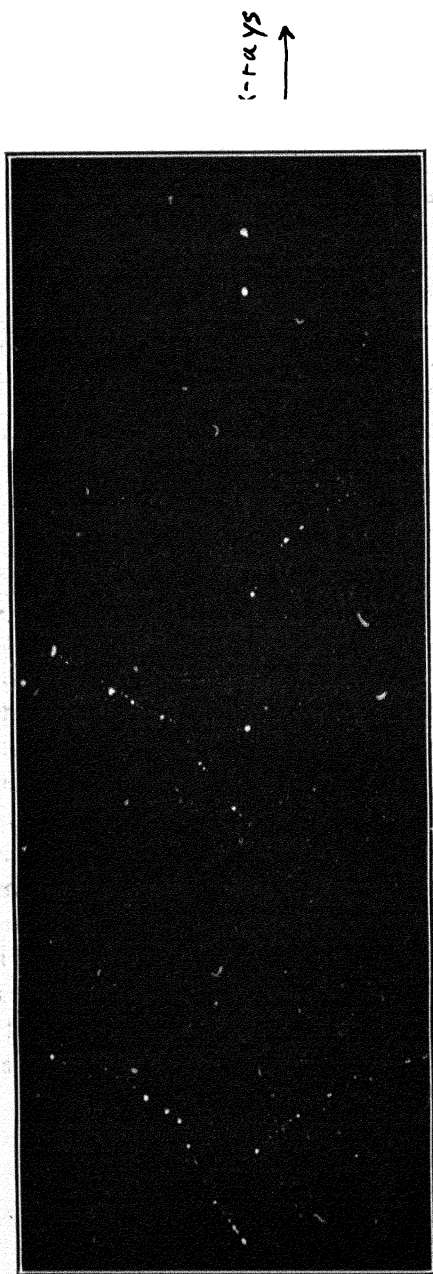

FIG. 95.

X-rays  
↑



FIG. 96.

X-rays  
↑



FIG. 97.

the number of quanta of X-ray energy scattered by the air in the expansion chamber, which means that they must be somehow associated with the scattering of X-rays. In the next chapter we shall show that we can accurately describe their properties on the assumption that when a quantum of X-rays is scattered it is deflected by a single electron. The change in momentum of the X-ray quantum due to its change in direction is balanced by a recoil of the electron which deflects the quantum, and which is itself ejected from the atom, forming a beta ray. We may therefore call beta particles of the shorter type, *recoil electrons*.

In this chapter we shall confine ourselves to a discussion of the properties of the beta rays of the photoelectron type.

#### 104. *Speed of the Photoelectrons*

We have mentioned above (pp. 223 and 226) the experiments which have shown that Einstein's equation (8.01) gives accurately the maximum speed of the photoelectrons ejected from metals by light. In the X-ray region the studies of Innes<sup>1</sup> Sadler,<sup>2</sup> Beatty,<sup>3</sup> Whiddington,<sup>4</sup> and Moseley<sup>5</sup> taken together showed<sup>6</sup> that the maximum energy of electrons ejected by X-rays of frequency  $\nu$  is very nearly equal to  $h\nu$ . This is evidently in accord with the photoelectric equation, since the fastest electrons will come from near the surface of the atom where  $w_0$  is negligible compared with  $h\nu$  for X-rays.

From measurements of the ionization of gases by X-rays, Barkla and Shearer<sup>7</sup> were led to the conclusion that all X-ray photoelectrons, from whatever part of the atom they are ejected, have on leaving the atom a speed corresponding to a whole quantum of the incident radiation. Richardson<sup>8</sup> called

<sup>1</sup> P. D. Innes, Proc. Roy. Soc. **79**, 442 (1907).

<sup>2</sup> C. A. Sadler, Phil. Mag. **19**, 337 (1910).

<sup>3</sup> R. T. Beatty, Phil. Mag. **20**, 320 (1910).

<sup>4</sup> R. Whiddington, Proc. Roy. Soc. **86**, 360 and 370 (1912).

<sup>5</sup> H. G. J. Moseley, Phil. Mag. **27**, 703 (1914).

<sup>6</sup> O. W. Richardson, "The Electron Theory of Matter," (1914) Chap. XIX.

<sup>7</sup> C. G. Barkla and G. Shearer, Phil. Mag. **30**, 745 (1915).

<sup>8</sup> O. W. Richardson, Proc. Roy. Soc. **94**, 269 (1918).

attention to the surprising nature of this conclusion, since if each photoelectron represents the absorption of energy  $h\nu$ , we should expect the kinetic energy of the photoelectron to be less than this by the very considerable amount of energy required to remove the electron from its parent atom. Some experiments by Simons<sup>1</sup> on the range of the X-ray photoelectrons in thin screens suggested that different groups of velocities were present, corresponding to different energy losses by the electrons ejected from different parts of the atom. The existence of beta rays of these energy groups was finally established in a series of beautiful experiments by de Broglie<sup>2</sup> in the X-ray region and by Ellis<sup>3</sup> in the region of  $\gamma$ -rays, both using the magnetic spectrometer.



FIG. 98.

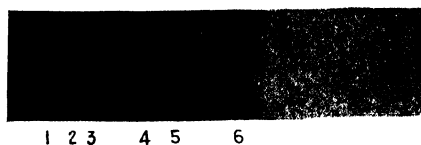

FIG. 99.

Two of de Broglie's photographs, showing the beta ray spectra from a silver screen traversed by X-rays from a tungsten target, are reproduced in Figs. 98 and 99. The two figures differ in that the magnetic field was stronger for Fig. 99. Each of the lines appearing in these photographs can be ascribed to electrons from some definite energy level of silver excited by some definite spectrum line. Thus the prominent double line

<sup>1</sup> I. Simons, *Phil. Mag.* **4**, 120 (1921).

<sup>2</sup> M. de Broglie, *C. R.* **172**, pp. 274, 527, 746 and 806 (1921); *Jour. de Phys. et Radium* **2**, 265 (1921).

<sup>3</sup> C. D. Ellis, *Proc. Roy. Soc.* **99**, 261 (1921).

4 is due to electrons ejected from the  $K$  level of silver by the  $K\alpha$  doublet of tungsten. De Broglie calculates the velocities to be expected in this case from Einstein's photoelectric equation written in the form

$$mc^2 \left( \frac{1}{\sqrt{1 - \beta^2}} - 1 \right) = h\nu - h\nu_p, \quad (8.05)$$

where  $\beta c$  is the velocity of the particle,  $\nu$  the frequency of the incident X-rays and  $\nu_p$  the critical frequency of the energy level from which the photoelectron is ejected. He finds that the relativity expression for the kinetic energy (see eq. (21), Appendix II) must be used for these high speed electrons instead of the approximate expression  $\frac{1}{2}mv^2$  which is satisfactory for the low speed electrons ejected by light. Combining equations (8.04) and (8.05) and solving for  $RH$  in terms of the known values of  $\nu$  and  $\nu_p$ , de Broglie finds that for the line produced by electrons from the silver  $K$  level excited by the tungsten  $K\alpha_1$  rays, i.e., for the  $K\alpha_1W - KAg$  line,  $RH$  is 630, where as the experimentally determined value of  $RH$  is 631. In a similar manner, line 1 of Fig. 98 is identified with the  $K\alpha Ag - LAg$  line, produced by electrons from the silver  $L$  level excited by the fluorescent  $K\alpha$  rays from silver.

### 105. Determination of Energy Levels

Having thus established the validity of equation (8.05), measurements of the electron speeds  $\beta c$  can be applied to determine the critical frequencies  $\nu_p$  of the energy levels if  $\nu$  is known, or to determine the unknown frequency  $\nu$  of the incident radiation if  $\nu_p$  is known. Robinson<sup>1</sup> has thus found the energy or critical frequency of the outer shells of many atoms. He uses the  $K$  line of copper to excite the photoelectrons from thin films of the substance under investigation, and obtains a large, comparatively uniform magnetic field by means of a pair of Helmholtz coils. The accuracy of his results probably exceeds

<sup>1</sup>H. R. Robinson, Proc. Roy. Soc. 104, 455 (1923); Phil. Mag. 50, 241 (1925). Cf. also R. Whiddington, Phil. Mag. 43, 1116 (1922).

in many cases that of the values calculated from the observed wave-lengths by help of the combination principle.

### 106. *Wave-lengths of $\gamma$ -rays*

In the hands of Ellis,<sup>1</sup> Thibaud<sup>2</sup> and others<sup>3</sup> the magnetic beta ray spectrometer has given important knowledge of wave-lengths of  $\gamma$ -rays, which can be measured only with difficulty if at all by the crystal spectrometer. The energy level from which the electrons are ejected can be determined by comparing the spectra of the photoelectrons from two different elements such as lead and tungsten. It is found that the difference of the beta ray energies in the two cases is equal to the difference in the energies of the corresponding  $K$  shells. Thus the frequency of the  $\gamma$ -rays is calculable from equation (8.05) if  $\nu_p$  is taken as the critical  $K$  frequency of the element from which the electrons are ejected. In Table VIII-1 are given some of the  $\gamma$ -ray wave-lengths which have thus been determined.

By comparing the velocities of the photoelectrons ejected by  $\gamma$ -rays from different elements, Thibaud (loc. cit.) has shown that the photoelectric equation (8.05) holds with precision even for electrons of the highest speed. This constitutes also an important test of the relativity expression for the kinetic energy of a rapidly moving particle.

### 107. *Compound Photoelectric Effect*

Wilson<sup>4</sup> and Auger<sup>5</sup> have recently shown by the cloud expansion method that very often not only one but a group of as many as four photoelectrons may be ejected simultaneously from a single atom. A photograph showing this remarkable phenomenon is reproduced in Fig. 100. It would seem that the initial action of the X-ray quantum is to eject an electron from

<sup>1</sup> C. D. Ellis, Proc. Roy. Soc. 100, 1 (1922); Proc. Camb. Phil. Soc. 22, 369 (1924).

<sup>2</sup> J. Thibaud, C. R. 178, 1706 (1924); 179, pp. 165, 1053 and 1322 (1924).

<sup>3</sup> Ellis and Skinner, Proc. Roy. Soc. 105, 165 and 185 (1924); L. Meitner, Zeits. f. Phys. 11, 35 (1922); Black, Proc. Roy. Soc. 106, 632 (1924).

<sup>4</sup> C. T. R. Wilson, Proc. Roy. Soc. 104, 192 (1923).

<sup>5</sup> P. Auger, C. R. 180, 65 (1925); J. de Phys. et Radium, 6, 205 (1925).

perhaps the *K* level of a krypton atom. The vacancy in the *K* level may be filled by an electron falling from an *L* level, and the resulting *K $\alpha$*  ray may eject from the same atom another

TABLE VIII-1  
 $\gamma$ -RAY LINE SPECTRA

Element	$\lambda$ in $10^{-11}$ cm.	Intensity	Element	$\lambda$ in $10^{-11}$ cm.	Element	$\lambda$ in $10^{-11}$ cm.
UX <sub>1</sub> <sup>1</sup>	136	. . . .	RaD <sup>1</sup>	265	AcX <sup>6</sup>	86
Ra <sup>2</sup>	66	. . . .	ThB <sup>3</sup>	67 3	. . .	80 4
RaB <sup>3</sup>	230 3	. . . .		52 6	. . .	79
	50 7	25	. . .	41 2	. . .	62
	47 5	6	ThC + C'' <sup>5</sup>	45 3	AcC'' <sup>5</sup>	46
	41 6	30	. . .	24 3		35
	34 6	40	. . .	21 2		27
	26 6 <sup>3</sup>	. . . .	. . .	15 5		25.7
RaC <sup>3</sup>	44 9	4	MsTh <sub>2</sub> <sup>5</sup>	37 2		
	37 1	2	. . .	26 8		
	31 7	6	. . .	13 5		
	28 8	3	. . . . .	12 75		
	20 2	30				
	16 5 <sup>5</sup>	. . . .	RaAc <sup>6</sup>	390		
	13 1	7	. . . . .	282		
	10 92	13	. . . . .	232		
	9 90	7	. . . . .	201		
	8 66	16	. . . . .	123		
	6 94	8	. . . . .	82.8		
5 56	3	. . . . .	63 0			
			48 6			
			43 8			
			41 1			

<sup>1</sup> L. Meitner, Zeits. f. Phys. 17, 54 (1923).

<sup>2</sup> O. Hahn and L. Meitner, Zeits. f. Phys. 26, 161 (1924).

<sup>3</sup> C. D. Ellis and W. A. Wooster, Proc. Camb. Phil. Soc. 22, 853 (1925).

<sup>4</sup> L. Meitner, Zeits. f. Phys. 11, 35 (1922).

<sup>5</sup> J. Thibaud, Thesis, Paris (1925).

<sup>6</sup> L. Meitner, Zeits. f. Phys. 34, 815 (1925).

electron from an *L* level. Two *L* rays may now be produced by electrons falling into the two vacancies in the *L* shell, and these may in turn eject two electrons from the *M* or outer levels of the same atom. Thus the single initial quantum produces 4

photoelectrons of varying velocities. From a study of their ranges, Auger has shown experimentally that the energy of all these beta rays taken together is no greater than that of the original quantum.

This compound photoelectric effect is perhaps the explanation of the small change observed in the ionization current of a Bragg spectrometer on the two sides of the absorption limit of iodine when the ionization chamber is filled with methyl iodide. It had been supposed that when the characteristic  $K$  rays of iodine are excited, they would carry with them into the walls of the chamber much of the energy of the primary beam. The

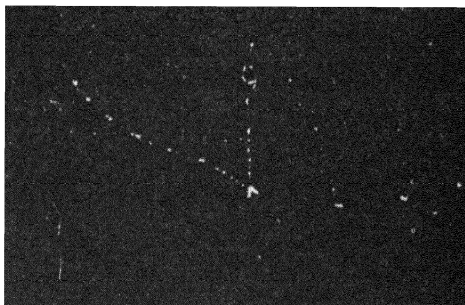

FIG. 100.

fact that experiment shows only a very small reduction in the ionization as the wave-length becomes shorter than the iodine  $K$  limit must mean that a large part of the resulting  $K$  radiation never escapes from the atom from which the photoelectron is ejected. A similar phenomenon occurs in the case of the beta rays from radioactive substances, where it is found that  $\gamma$ -ray starting from the nucleus of the atom very often spends itself in ejecting a photoelectron from the same atom.<sup>1</sup>

#### 108. *Spatial Distribution of the Photoelectrons*

Experiments by the cloud expansion method have shown<sup>2</sup> that the most probable direction in which the photoelectron is

<sup>1</sup> M. de Broglie and J. Thibaud, C. R. 180, 179 (1925).

<sup>2</sup> A. H. Compton, Bulletin National Res. Coun. No. 20, p. 25 (1922). C. T. R. Wilson, Proc. Roy. Soc. 104, 1 (1923). F. W. Bubb, Phys. Rev. 23, 137 (1924). P. Auger, C. R. 178, 1535 (1924).

ejected from an atom is nearly the direction of the electric vector of the incident wave, but with an appreciable forward component to its motion. There is, however, a very considerable variation in the direction of emission. If, for example, we plot the number of photoelectrons ejected at different angles with the primary beam we find, according to Auger,<sup>1</sup> the distribution shown in Fig. 101. Each of these three curves, taken at a different potential, represents the distribution of about 200 photoelectron tracks. It will be seen that as the potential on the X-ray tube or as the frequency of the X-rays is increased,

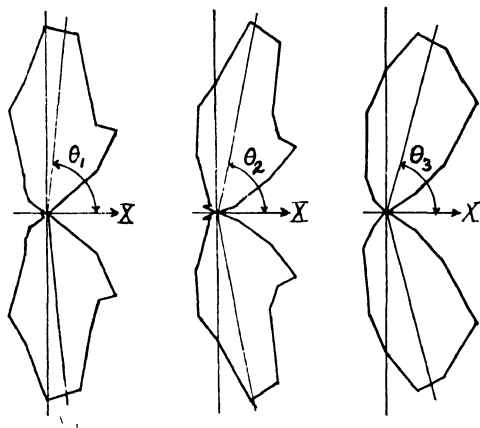

FIG. 101.

the average forward component of an electron's motion increases. Fig. 95 shows in a striking manner the fact that most of the photoelectrons initially have a forward component to their motion.

When polarized X-rays are used, there is a strong preponderance of the photoelectrons in or near the plane including the electric vector of the incident rays. Thus Fig. 102 shows the distribution found by Bubb<sup>2</sup> of the direction of the photoelectrons ejected from moist air when traversed by X-rays that have been polarized by scattering at right angles from a block of paraffin. Due to multiple scattering in the paraffin we have

<sup>1</sup> J. de Phys. et Rad. 6, 205 (1925).

<sup>2</sup> F. W. Bubb, loc. cit.

seen (p. 68) that the scattered rays are not completely polarized, and this is probably sufficient to account for the fact that some photoelectrons appear to start at right angles to the plane of the electric vector. This effect is doubtless similar in character to the "selective photoelectric effect," in which the number of electrons ejected by light from the liquid surface of sodium-potassium alloy is greater when the electric vector is in a plane perpendicular to the surface than when parallel to the surface.<sup>1</sup>

It was at one time supposed also that when light traverses thin films of metal the photoelectrons are given a motion with a forward component similar to that shown in Fig. 101 for the X-ray photoelectrons. Thus Stuhlman,<sup>2</sup> Kleeman<sup>3</sup> and others have found that if a thin metallic film is deposited on quartz more photoelectrons are ejected if the light passes from the quartz into the metal than if it passes from the metal into the quartz. It has been shown however by Partzsch and Hallwachs<sup>4</sup> that this effect is due largely and perhaps wholly to the fact that a greater part of the energy of the light is absorbed by the metal film when the light enters from the quartz side than when it enters from the free surface. The result is that the total number of electrons produced is greater when the light enters from the quartz into the metal. There is thus no convincing evidence that when ordinary light is absorbed by an atom the resulting photoelectron has any greater tendency to move forward than backward.

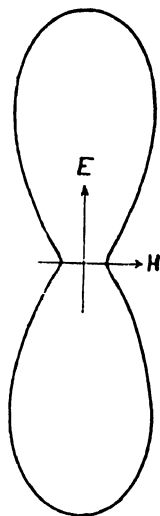

FIG. 102.

An effect analogous to this has long been known with the beta rays produced when matter is traversed by gamma rays.

<sup>1</sup> R. Pohl and P. Pringsheim, Verh. d. Deutsch. Phys. Ges. **13**, 474 (1911). H. F. Ives, Astrophys. J. **60**, 209 (1924).

<sup>2</sup> O. Stuhlman, Phil. Mag. **20**, 331 (1910); **22**, 854 (1911).

<sup>3</sup> R. D. Kleeman, Nature, May 19, 1910.

<sup>4</sup> A. Partzsch and W. Hallwachs, Ann. der Phys. **41**, 247 (1913).

Most of these beta rays are undoubtedly, however, electrons of the recoil type, and will be discussed in the next chapter under that head.

In the case of X-rays the longitudinal asymmetry was observed by ionization methods <sup>1</sup> before it was found in the cloud expansion photographs. Owen finds <sup>2</sup> that the degree of asymmetry does not differ for thin screens of different substances, and that the physical state has no appreciable effect.

#### HOW ARE THE PHOTOELECTRONS PRODUCED?

##### 109. *Inadequacy of Electromagnetic Waves*

Before discussing the production of photoelectrons from the standpoint of radiation quanta, let us see what success meets the attempt to account for them on the basis of electromagnetic waves. The fact that they are emitted approximately in the direction of the electric vector would suggest that the photoelectrons are ejected by the direct action of the electric field of the incident rays. If this were the case, however, we should expect the speed of the ejected electrons to be greater for greater intensity of radiation, whereas experiment shows that for the same wave-length intense sunlight ejects an electron no faster than does the feeble light from a star. Furthermore, the energy available from the electromagnetic wave is wholly inadequate. Thus in a recent experiment performed by Joffe and Dobron-sawov <sup>3</sup> X-rays were produced by the impact on a target of  $10^4$  to  $10^5$  electrons per second. Since an X-ray pulse is of the order of  $10^3$  waves in length (p. 55) or  $10^{-16}$  seconds in duration, the X-ray pulses must have followed each other at widely separated intervals. It was found, however, that photoelectrons were occasionally ejected from a bismuth particle which subtended a solid angle not greater than  $10^{-5}$ . It is clearly impossible that all the energy of an X-ray pulse which

<sup>1</sup> C. D. Cooksie, *Nature* **77**, 509 (1908); *Phil. Mag.* **29**, 37 (1912). R. T. Beatty, *Proc. Camb. Phil. Soc.* **15**, 492 (1910).

<sup>2</sup> E. A. Owen, *Proc. Phys. Soc.* **30**, 133 (1918).

<sup>3</sup> A. Joffe and N. Dobron-sawov, *Zeits. f. Phys.* **34**, 889 (1925).

has spread out in a spherical wave should spend itself on this bismuth particle. Thus on the wave theory the ejection of the photoelectron, which has almost as much energy as the original cathode electron, could not have been accomplished by a single pulse. It cannot therefore be the direct action of the electric vector of a wave, taken in the usual sense, which has thrown out the electron.

We may assume on the other hand that the energy is gradually absorbed in the bismuth particle of Joffe's experiment until an amount  $h\nu$  has accumulated, which is then spent in ejecting the photoelectron. Though it is difficult to imagine a mechanism whereby such energy storage could be accomplished, we can hardly call the process impossible. New difficulties however arise. Why do the photoelectrons tend to start in the direction of the electric field of the incident wave? If we suppose that it is the action of the wave which exerts the final force required to liberate the electron, we are unable to explain why there exists a tendency for the electron to start with a large component, in a *forward* direction. The accumulation hypothesis is thus also open to serious difficulties.

It is apparent that in order to account for the transfer of energy first from the cathode electron to the X-ray, and then from the X-ray to the photoelectron, we must either give up our old view that the X-ray consists of a spherical wave or abandon the doctrine of the conservation of energy. To Bohr, Kramers and Slater it at one time seemed the more probable view to suppose that energy was not conserved in the production of photoelectrons. They supposed<sup>1</sup> that on the average the energy absorbed from the beam of radiation would be equal to the average energy appearing as photoelectrons, but that any individual photoelectron would start as though it had suddenly received this energy without removing this energy from the remainder of the system. That is the energy would be conserved statistically, but not during the ejection of an individual electron. We see that with this assumption the motion of the photoelectrons may be the same as if they were

<sup>1</sup> N. Bohr, H. A. Kramers and J. C. Slater, *Phil. Mag.* 47, 785 (1923).

ejected by radiation quanta, while the idea of radiation in the form of spherical waves may still be retained. It is accordingly difficult to devise an experiment with photoelectrons which will distinguish between this view and that of radiation quanta.<sup>1</sup> We shall see, however, that such a crucial experiment can be performed with scattered X-rays and recoil electrons, and that the decision is in favor of the radiation quantum hypothesis.

### 110. *Photoelectrons and Radiation Quanta*

Let us consider what happens when a radiation quantum gives up its energy and its momentum to a system consisting of an electron and the remainder of the atom of which the electron is initially a part. We shall suppose that both the energy and momentum of the system are conserved, and for sake of simplicity shall imagine that the electron and the atom are initially at rest and that it requires no energy to free the electron from the atom. These conditions supply the following energy equation

$$h\nu = mc^2 \left( \frac{1}{\sqrt{1 - \beta^2}} - 1 \right) + \frac{1}{2}MV^2, \quad (8.06)$$

<sup>1</sup> Since this was written Bothe has performed an experiment based upon the photoelectric effect which favors the hypothesis of radiation quanta. *Phys. Zeits.*, 1926. Fluorescent  $K\alpha$  radiation from a thin copper foil is excited by the incident X-rays. The emitted rays are so feeble that only about 5 quanta of energy are radiated per second. Two Geiger point counting chambers are mounted one on either side of the copper foil, in each of which an average of 1 photoelectron is produced and recorded for about 20 quanta radiated by the foil. The experiment thus resembles that described on page IX. 23.

If we assume that the fluorescent radiation is emitted in quanta of energy but proceeds in spherical waves in all directions, there should thus be about one chance in 20 that the recording of a photoelectron in one chamber should be simultaneous with the recording of a photoelectron in the other. On the idea that each quantum of radiation proceeds in a definite direction, however, there is no reason to anticipate such coincidences.

The experiments showed no coincidences other than those which were explicable by such sources as high-speed beta particles which traverse both chambers. This is in accord with the directed quantum theory of radiation.

This experiment is not, however, by itself a decisive test of the theory of Bohr, Kramers and Slater. For they might consistently predict continuous "virtual radiation" from the copper foil, so that the photoelectrons should appear at random intervals in the counting chambers, just as the experiments indicate.

where  $\beta c$  is the final speed of the electron,  $M$  is the mass and  $V$  the final speed of the atom. Since the momentum of a radiation quantum is  $h\nu/c$  (cf. Appendix I, eq. 5), we have also three momentum equations, thus:

$$X \quad \frac{h\nu}{c} = pl_1 + Pl_2 \quad (8.07)$$

$$Y \quad 0 = pm_1 + Pm_2 \quad (8.08)$$

$$Z \quad 0 = pn_1 + Pn_2 \quad (8.09)$$

where  $p$  is the final momentum of the electron, and  $P$  is that of the atom, i.e.,

$$p = \frac{m\beta c}{\sqrt{1 - \beta^2}}, \quad (8.10)$$

and

$$P = MV. \quad (8.11)$$

Also for the direction cosines we have

$$l_1^2 + m_1^2 + n_1^2 = 1, \quad (8.12)$$

and

$$l_2^2 + m_2^2 + n_2^2 = 1. \quad (8.13)$$

We have here 10 quantities to be determined,  $B$ ,  $V$ ,  $p$ ,  $P$ ,  $l_1$ ,  $m_1$ ,  $n_1$ ,  $l_2$ ,  $m_2$ ,  $n_2$ , and 8 equations. To obtain a solution we need two more equations, which can only be supplied by making some further assumption regarding the manner in which the quantum acts on the atom. Probably the simplest such assumption that can be introduced is that used by Bubb<sup>1</sup> to account for the distribution of the photoelectrons shown in Fig. 102. We shall state it in the form that the impulse imparted to the *atom* is in the direction of the electric vector.<sup>2</sup> If

<sup>1</sup> F. W. Bubb, Phys. Rev. 23, 137 (1924).

<sup>2</sup> A consideration of the radiation pressure exerted according to the classical electromagnetic theory gives important suggestions as to the manner in which the forward impulse may be imparted to the electron. Take the simple case of a wave propagated along the X-axis whose electric vector is  $E_y = A \cos pt$  traversing an electron which though free moves against a frictional force  $2km \, dy/dt$ . The equation of motion is

$$m \frac{d^2y}{dt^2} + 2km \frac{dy}{dt} = Ae \cos pt. \quad (1)$$

we consider an incident ray which is polarized with its electric vector along the  $Y$  axis, this supplies the additional equations,

$$l_2 = 0 \quad \text{and} \quad n_2 = 0. \quad (8.14)$$

After the transient motion has died out, the displacement at any time is then

$$y = -A' \cos(pt + \delta), \quad (2)$$

where

$$A' = Ae/mp^2,$$

and

$$\delta = \tan^{-1} 2k/p = 2k/p,$$

$$\text{if } k \ll p.$$

The effect of the magnetic field is to exert a force of magnitude  $H_z \frac{e}{c} dy/dt$  along the  $X$ -axis, where  $H_z$  is in e.m.u. and is also equal to  $A \cos pt$ . Thus at any instant the magnetic vector exerts a force in the direction of propagation of the wave, of magnitude

$$F_x = A \cos pt \frac{e}{c} A' p \sin(pt + \delta),$$

using the value of  $dy/dt$  given by equation (2). But

$$\begin{aligned} \sin(pt + \delta) &= \sin pt \cos \delta + \cos pt \sin \delta \\ &= \sin pt + \delta \cos pt, \end{aligned}$$

since  $\delta \ll 1$ . Thus

$$\bar{F}_x = AA' \frac{pe}{c} (\sin pt \cos pt + \delta \cos^2 pt). \quad (3)$$

The average value of this force over a complete cycle is

$$\begin{aligned} \bar{F}_x &= AA' \frac{pe}{c} \cdot \frac{p}{2\pi} \left\{ \int_0^{2\pi/p} \sin pt \cos pt dt + \delta \int_0^{2\pi/p} \cos^2 pt dt \right\} \\ &= AA' \frac{pe\delta}{2c}. \end{aligned} \quad (4)$$

It will be seen from this that if there were no friction,  $\delta$  would be zero and the force due to the magnetic field would be half of the time forward and half of the time backward. It is only when the field does work on the electron, as against the frictional force, that an average forward force on the electron exists.

The rate at which work is done against the frictional force is

$$\begin{aligned} P &= F_y \frac{dy}{dt} = 2km \frac{dy}{dt} \cdot \frac{dy}{dt} \\ &= 2km \cdot A'^2 p^2 \sin^2(pt + \delta), \end{aligned}$$

With as many equations as unknowns the problem can now be completely solved.

Combining equations (8.13) and (8.14) we obtain  $m_2 = 1$ , which means that the atom proceeds along the  $Y$ -axis. From (8.09) and (8.14) it follows that  $n_1 = 0$ , whence the photoelectron is ejected in the  $XY$  plane. From equation (8.08), since  $m_2 = 1$ ,

$$p = -P/m_1, \quad (8.15)$$

that is,  $p$  is greater than, but of the same order of magnitude, as  $P$ . To find how the kinetic energy is distributed between the atom and the electron, let us write this energy in terms of the momentum. From (8.10) it follows that

$$\frac{1}{1 - \beta^2} = 1 + \frac{p^2}{m^2 c^2},$$

or if we write

$$b \equiv p/mc, \quad (8.16)$$

and the average ratio of work or power is

$$\begin{aligned} \bar{P} &= \frac{p}{2\pi} \cdot 2km p^2 A'^2 \int_0^{2\pi/p} \sin^2(pt + \delta) dt \\ &= A'^2 \cdot kmp^2. \end{aligned} \quad (5)$$

Expressing  $A'$  in terms of  $A$ , this becomes

$$\bar{P} = A^2 e^2 k / mp^2. \quad (6)$$

This is the average energy absorbed per unit time by the electron.

The impulse, or change in momentum, per unit time is identical with the average force, which is given by equation (4). Writing  $A'$  and  $\delta$  in terms of  $A$ ,  $k$  and  $p$ , this becomes

$$\bar{F} = A^2 e^2 k / mp^2 c. \quad (7)$$

Thus

$$\bar{F}/P = 1/c, \quad (8)$$

is ratio of the momentum to the energy imparted to the electron, in accord with equation 25 of Appendix I.

Regarding the positive nucleus, because of its large mass its motion is relatively sluggish, and the magnetic force is by equation (7) much less than that on the electron. Thus the impulse received by the positive nucleus will be negligible. It thus appears a reasonable assumption that the momentum imparted to the positive part of the atom by a radiation quantum is likewise negligible as compared with that imparted to the electron.

then

$$\frac{1}{1 - \beta^2} = 1 + b^2, \quad (8.17)$$

and the kinetic energy of the electron is

$$T_e = mc^2 \left( \frac{1}{\sqrt{1 - \beta^2}} - 1 \right) = mc^2 (\sqrt{1 + b^2} - 1) \quad (8.18)$$

$$= \frac{1}{2} mc^2 b^2 (1 - \frac{1}{4} b^2 + \dots). \quad (8.19)$$

Similarly the kinetic energy of the atom is

$$T_a = \frac{1}{2} M V^2 = \frac{1}{2} P^2 / M,$$

or if we define a quantity

$$B \equiv P / mc, \quad (8.20)$$

then

$$T_a = \frac{m}{M} \cdot \frac{1}{2} mc^2 B^2. \quad (8.21)$$

But from equation (8.15) it follows that  $B \approx b$ . Comparing (8.19) and (8.21) we see therefore that  $T_a$  is less than  $T_e$  by a ratio of the order of  $m/M$ . Since this is a ratio of the order of  $10^{-4}$ , we can without appreciable error neglect the second term on the right hand side of equation (8.06). We thus have

$$mc^2 \left( \frac{1}{\sqrt{1 - \beta^2}} - 1 \right) = h\nu, \quad (8.22)$$

which is the form that Einstein's equation (8.05) takes for this case, though we recognize that this expression neglects the small amount of energy spent in setting the atom in motion.

The direction of ejection of the photoelectron is given by equation (8.07) as

$$l_1 = \frac{h\nu}{pc},$$

since  $l_2 = 0$ . Writing  $p = bmc$  as before, this becomes

$$\begin{aligned} l_1 &= \frac{1}{b} \frac{h\nu}{mc^2} \\ &= \alpha/b, \end{aligned} \quad (8.23)$$

where we define

$$\alpha \equiv \frac{h\nu}{mc^2} = \frac{h}{mc\lambda}. \quad (8.24)$$

But from equation (8.22) it follows that

$$\frac{I}{\sqrt{1 - \beta^2}} = I + \alpha,$$

and comparing this with (8.17) we find that

$$b = \sqrt{2\alpha + \alpha^2}. \quad (8.25)$$

Expression (8.23) thus becomes<sup>1</sup>

$$l_1 = I/\sqrt{1 + 2/\alpha}. \quad (8.26)$$

If we call  $\theta$  the angle between the direction of propagation of the incident X-ray and the direction in which the photoelectron is ejected, we thus have

$$\left. \begin{aligned} \cos \theta = l_1 &= I/\sqrt{1 + 2/\alpha} \\ \tan \theta &= \sqrt{2/\alpha} \end{aligned} \right\}. \quad (8.27)$$

In calculating the angle from this expression it is convenient to note that  $\alpha$  may be written as

$$\alpha = \gamma/\lambda \quad (8.28)$$

where

$$\gamma \equiv \frac{h}{mc} = 0.0243\text{\AA}. \quad (8.29)$$

We see that  $\alpha$  is small compared with unity except for very hard X-rays and  $\gamma$ -rays. Thus equation (8.27) predicts for ordinary X-rays an expulsion at nearly 90 degrees. The following table shows the angles to be anticipated for different wavelengths.

<sup>1</sup>This expression has been derived from similar considerations by F. W. Bubb, Washington Univ. Studies, 11, 161 (1924); Phil. Mag. 48, 824 (1925). W. Bothe, Zeits. f. Phys. 26, 74 (1924). P. Auger C. R. 178, 929 (1924). Considerations of this character appear to have been applied to the problem first by O. W. Richardson, Phil. Mag. 25, 144 (1913). W. F. G. Swann, Phil. Mag. 25, 534 (1913).

TABLE VIII-2

THEORETICAL MAXIMUM EMISSION ANGLE FOR PHOTOELECTRONS

Radiation	Wave-length (Ångströms)	$\alpha$	$\theta$	$90^\circ - \theta$
Hard $\gamma$ -rays . . . . .	.0243	1	$55^\circ$	$35^\circ$
Hard X-rays . . . . .	.243	.1	$76^\circ 27'$	$13^\circ 33'$
Soft X-rays . . . . .	2 43	.01	$85^\circ 58'$	$4^\circ 2'$
	24 3	.001	$88^\circ 43'$	$1^\circ 17'$
Extreme ultraviolet . . . . .	243.	.0001	$89^\circ 35.7'$	$24 3'$
Ultraviolet . . . . .	2430.	.00001	$89^\circ 52.4'$	$7 6'$

### III. *Experimental Test*

In the case of ultraviolet light the fact that under certain conditions, as in the selective photoelectric effect, the photoelectrons are emitted most strongly along the electric vector is in support of this calculation. The very small component of forward motion indicated by Table VIII-2 for ultraviolet light would not be enough to give any measurable excess of forward over backward photoelectrons, and is thus also in accord with the rather uncertain data described above.

The only really significant test of this theory is in its applications to X-ray photoelectrons. In Fig. 101 I have drawn the lines  $\theta_1$ ,  $\theta_2$ , and  $\theta_3$ , for the three curves, as calculated by Auger from equation (8.27). It will be seen that they fall very satisfactorily in the direction of maximum emission of the photoelectrons. This may be taken as a proof that the quantum imparts not only its energy but also its momentum to the photoelectron.

### III.2. *Bubb's Theory of Spatial Distribution*

Several attempts have been made to account for the fact that the photoelectrons are emitted over a wide range of angles instead of in a definite direction as would be suggested by the calculation just given. Thus Bubb<sup>1</sup> has considered the effect

<sup>1</sup> F. W. Bubb, *Phil. Mag.* 40, 824 (1925).

of superposing on the electron's final motion as calculated above its momentum in its atomic orbit just before ejection from the atom, subject to the condition that the electron's final energy shall be that given by equation (8.05). His theory can be interpreted geometrically with the help of Fig. 103. We let  $OX$  represent the direction of propagation of the X-ray, and draw  $OY$  in the direction of its electric vector. About the origin  $O$  we draw a sphere whose radius  $p$  represents the final

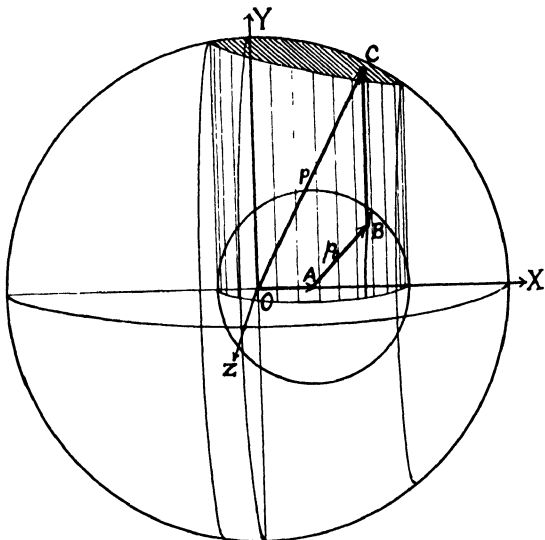

FIG. 103.

momentum of the electron according to Einstein's photoelectric equation, i.e.,  $p$  is given by the expression (cf. eq. 8.18),

$$h\nu - w = mc^2(\sqrt{1 + p^2/m^2c^2} - 1), \quad (8.30)$$

where  $w$  is the energy required to remove the electron from the atom. Along the  $X$ -axis we draw the vector  $OA = h\nu/c$ , which represents the momentum of the quantum which we suppose is all transferred to the electron, presumably by the action of the quantum's magnetic vector.<sup>1</sup> We now describe about  $A$  a sphere of radius  $AB = p_0$ , corresponding to the momentum of

<sup>1</sup> Cf. note, p. 22.

the electron in its orbit at the moment of interaction with the quantum. The direction of this vector is random, and we assume that the probability of interaction with the quantum is equally probable for all directions of the vector  $AB$ . The quantum is supposed to impart to the electron also a sideways impulse  $BC$ , corresponding to the action of the electric vector of the wave. The possible directions of emission of the photoelectrons then are represented by the projection on the outer sphere of the surface of the inner sphere, shown as the shaded portion of the outer sphere.

If the electrons are moving in circular Bohr orbits (as assumed in drawing Fig. 103), it can be shown that the momentum  $AB$  is

$$\begin{aligned} p_0 &= mc\sqrt{2\alpha_0 - \alpha_0^2}/(1 - \alpha_0), & (8.31) \\ &= mc\sqrt{2\alpha_0}, \text{ approx.,} \end{aligned}$$

where  $\alpha_0 = h\nu_0/mc^2$ ,  $\nu_0$  being the critical ionization or absorption frequency for the electron in the orbit considered. From equation (8.30), noting that  $w = h\nu_0$ , we find that

$$p = mc\sqrt{2(\alpha - \alpha_0) + (\alpha - \alpha_0)^2}, \quad (8.32)$$

which, when  $\alpha_0$  is small compared with  $\alpha$ , becomes

$$p = mc\sqrt{2\alpha}, \text{ approx.}$$

Thus for loosely bound electrons,

$$p_0/p = \sqrt{\alpha_0/\alpha} = \sqrt{\nu_0/\nu}. \quad (8.33)$$

In the case of electrons ejected from the  $K$  shell of argon by X-rays of wave-length .18A, corresponding to curve 3 of Fig. (8-08), we have  $\nu_0/\nu = \lambda/\lambda_0 = .18/3.9$  (see Table VI-7), whence  $p/p_0 = .22$ . Also we have  $OA = h\nu/c = \alpha.mc$ , so that  $OA/p = \sqrt{\alpha/2} = .258$ . Thus according to Bubb's theory, since  $OA > p_0$ , all the photoelectrons should be ejected at angles less than 90 degrees, and be distributed over a range of angles  $\theta$  of about  $2 \times .22$ , or 25 degrees. The angular distribution thus calculated is represented in Fig. 104 by the broken line. The experimental points are those of Auger's experimental

curve 3 of Fig. 101. It will be seen that the agreement with experiment is not very satisfactory. Moreover, the differences are even more prominent if we consider also the photoelectrons from the  $L$  orbits.

Another inherent difference between the results of Bubb's theory and the experiments is that whereas the theory indicates that the photoelectron directions should be more spread out as the ratio  $\nu_0/\nu$  increases (eq. 8.33), such an effect does not appear in Auger's experiments shown in Fig. 101. We have seen also (p. 18) that Owen's experiments show the same distribution for different elements used as sources of photoelectrons, though the values of  $\nu_0$  differ from element to element. If these experiments are reliable it is not possible to account for the spreading of the photoelectrons as due directly to their momenta before expulsion from the atom.

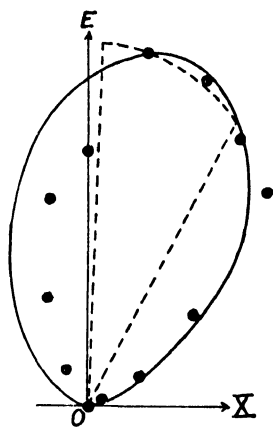

FIG. 104.

### 113. *Theory of Auger and Perrin*

Auger and Perrin have made the alternative hypothesis that the direction of ejection of the electron is that of the electron's velocity at the moment the quantum traverses the electron.<sup>1</sup> They assume however that the probability that the ejection will occur is proportional to  $\cos^2 \angle E\nu$ , where  $E$  is the direction of the electric vector of the X-ray and  $\nu$  is the direction of the electron's velocity. Thus in Fig. 105, if the  $X$ -axis is in the direction of propagation and the  $Y$ -axis is in the direction of the electric vector, and if  $OP$  is the direction of the electron's motion in its orbit,  $OP$  is also the direction in which the photoelectron will be ejected, and the probability of its ejection is proportional to

$$\cos^2 \zeta d\omega = \sin^3 \theta \cos^2 \Psi d\theta d\Psi. \quad (8.34)$$

<sup>1</sup> P. Auger and F. Perrin, C. R. 180, 1742 (1925). P. Auger, C. R. 180, 1939 (1925).

The probability of emission between  $\theta$  and  $\theta + d\theta$  is thus

$$P_{\theta}d\theta = \frac{\sin^3 \theta d\theta \int_0^{2\pi} \cos^2 \Psi d\Psi}{\int_0^{\pi} \sin^3 \theta d\theta \int_0^{2\pi} \cos^2 \Psi d\Psi} = \frac{3}{4} \sin^3 \theta d\theta. \quad (8.35)$$

Similarly, between  $\Psi$  and  $\Psi + d\Psi$  the probability of emission is

$$P_{\Psi}d\Psi = \frac{\cos^2 \Psi d\Psi \int_0^{\pi} \sin^3 \theta d\theta}{\int_0^{2\pi} \cos^2 \Psi d\Psi \int_0^{\pi} \sin^3 \theta d\theta} = \frac{1}{\pi} \cos^2 \Psi d\Psi \quad (8.36)$$

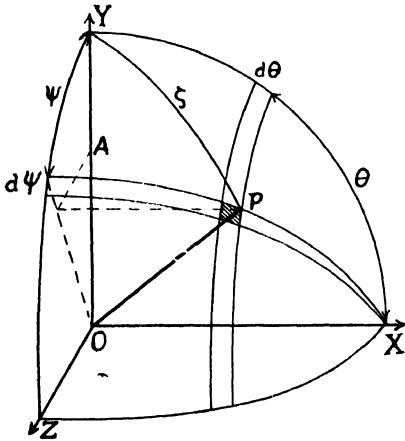

FIG. 105.

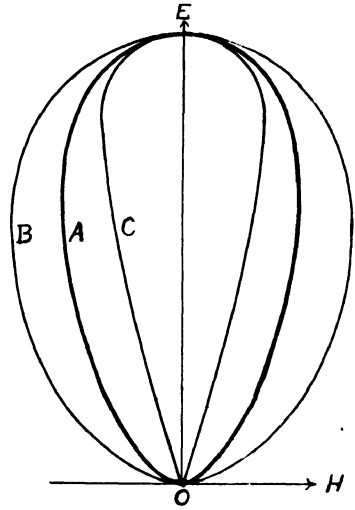

FIG. 106.

These expressions agree with the experiments in predicting a distribution which is the same for different elements used as sources of photoelectrons, but quantitatively they are not in much better accord with the observed distribution than are Bubb's equations. Thus in Fig. 106 are shown *A*, Bubb's experimental distribution curve for polarized X-rays, similar to Fig. 102 but corrected for the incompleteness of the polarization; *B*, the distribution calculated from (8.36), and *C*, the dis-

tribution calculated (approximately) from (8.33). It will be seen that Auger and Perrin's theory predicts greater spreading and Bubb's theory less spreading than is shown by the experiments.

Regarding the distribution for different angles  $\theta$ , equation (8.35) predicts no average forward component to the electron's motion. It would not be contrary to the spirit of the theory, however, to suppose that the photoelectron instead of proceeding in the direction of its original motion has an additional forward component to its momentum equal to  $h\nu/c$ , the momentum of the incident quantum. As this modified, the distribution predicted by equation (8.35) is shown as the solid line of Fig. 104. In this case the theory has fair success.

A third hypothesis for accounting for the spreading of the photoelectrons has been suggested by Bothe.<sup>1</sup> His assumptions are similar to those of Bubb, except that he supposes that an electron can be affected by the radiation quantum only when moving at right angles to the electric vector. The locus of the direction of emission is then a cone about the direction  $\theta = \tan^{-1} \sqrt{2/\alpha}$  as an axis, the apex angle of the cone being determined by the orbital momentum of the electron before ejection. According to Bothe's theory, as in Bubb's, the angular spreading of the photoelectrons should change with the source of photoelectrons and with the frequency of the X-rays.

#### 114. *Significance of the Experiments*

1. The fact that the electrons are ejected with an average forward component equal within experimental error to the momentum of the incident quantum means that no appreciable part of the momentum is spent on the remainder of the atom. This can only be the case if *the time of action of the quantum on the electron is short* compared with the time of revolution of the electron in its orbit.

2. If we retain the principle of momentum conservation, the direction of the photoelectron's motion must be that of the resultant of its original orbital momentum and of the impulse

<sup>1</sup> W. Bothe, *Zeits. f. Phys.* 26, 74 (1924).

imparted to it by the quantum. These experiments therefore afford direct information concerning the direction of the force exerted by a radiation quantum on an electron. By comparison with the classical concept of electromagnetic waves, we should look for something in the quantum analogous to an electric field which will exert a force perpendicular to the direction of propagation, and something analogous to the magnetic field which will give to the electron thus set in motion an impulse in the direction of propagation. The latter impulse we find—though since it is predicted also by the principle of conservation of momentum itself we can hardly draw from its existence any certain conclusion regarding a magnetic field in the quantum. The fact that there is at least a strong tendency for ejection of electrons in the direction of the electric vector seems at first sight to support the assumption of a force acting in the direction of the wave's electric field. But if it is true that the spreading of the photoelectrons is as great for atoms in which the electrons move slowly as for those in which they move at high speed, we cannot account for this equal spreading by assuming that the quantum imparts an impulse in the direction of the wave's electric vector. We must suppose rather, as Auger has done, that the direction of the impulse due to the quantum is determined jointly by the direction of the electric vector and some polarity (such as the direction of motion or acceleration or of magnetic moment) of the electron or the atom.

Such a complexity in the direction of the force on an electron in an electric field could not have been predicted by an extension of the classical electromagnetic theory. It would seem to complicate further our already difficult problem of interpreting the familiar concepts of electric and magnetic fields in terms of quanta. The difficulty follows directly from the experimental evidence that the spreading of the direction of the photoelectrons is independent of the wave-length and of the atom from which the electron is ejected. It is very desirable that these experiments be repeated under most varied conditions, for what is more fundamental in physics than a knowledge of the force exerted on an electron by a field of radiation?

115. *Number of Photoelectrons*

A series of experiments by W. H. Bragg,<sup>1</sup> Barkla,<sup>2</sup> and their collaborators suggested strongly that the true absorption (as opposed to scattering) of X-rays is due solely to the excitation of secondary beta rays. This conclusion was supported by C. T. R. Wilson's photographs<sup>3</sup> of the path of an X-ray beam through air, which showed no ionization along the path of the X-rays except that due to the action of the high speed electrons which were liberated. On this view, X-ray energy can be dissipated in only two ways, either by scattering or by the excitation of beta rays.

We have seen that there are two types of beta rays, those whose liberation excites the characteristic fluorescent radiation, and those which recoil after scattering a quantum of energy. According to the results of de Broglie and Ellis, each electron of the first type represents the absorption of one quantum of energy  $h\nu$  from the primary beam. The second type also probably represents a whole quantum of energy, the greater part of which appears as scattered radiation and the remainder as kinetic energy of the recoiling electron. The evidence is thus consistent with the view that each beta ray represents the removal of one quantum of energy from the primary beam, and that no other energy is lost except through true scattering.

It follows as a result of this conclusion that the energy "truly" absorbed per centimeter path of the X-ray beam should be

$$N h \nu = E_i \tau,$$

where  $N$  is the number of photoelectrons liberated,  $E_i$  is the energy of the X-rays incident upon the substance and  $\tau$  represents the true absorption coefficient (cf. *infra*, Appendix VI). Thus the number of photoelectrons liberated per centimeter path of the X-ray beam should be

$$N = E_i \tau / h \nu. \quad (8.37)$$

<sup>1</sup> W. H. Bragg, *Phil. Mag.* **20**, 385 (1910) *et al.*

<sup>2</sup> C. G. Barkla, *Phil. Mag.* **20**, 370 (1910) *et al.*

<sup>3</sup> C. T. R. Wilson, *Proc. Roy. Soc.* **87**, 288 (1912).

Partial support of this relation (20) is given by the fact that the number of electrons ejected from an atom is independent of its state of chemical combination,<sup>1</sup> as is also the energy absorbed by the atom. Moore has shown<sup>1</sup> also that the number of photoelectrons emitted by different light atoms traversed by X-rays is proportional to the fourth power of the atomic weight. This corresponds exactly with Owen's law (cf. *infra*, p. 192) that the true absorption per atom under similar circumstances is proportional to the fourth power of the atomic number. It follows therefore that the number of photoelectrons is proportional to the X-ray energy truly absorbed, as stated by equation (8.37). Although no direct experimental determination of the factor of proportionality has been made, there seems no reason to doubt that this factor is the energy quantum  $h\nu$ .

#### PASSAGE OF PHOTOELECTRONS THROUGH MATTER

##### 116. *Range*

The question of the range of a photoelectron is identical with that of any high speed electron traversing matter. The problem has been treated very simply by J. J. Thomson,<sup>2</sup> on the assumption that the energy lost by the beta particle is that spent in setting in motion the electrons near which it passes. If we suppose that  $\tau$  is the effective time during which the beta particle acts on the electron, and that  $\bar{F}$  is the mean force acting on the electron during that time, then the impulse imparted to the electron is

$$\bar{F}\tau = mv,$$

and the energy imparted is

$$\epsilon = \frac{m^2v^2}{2m} = \frac{\bar{F}^2\tau^2}{2m}.$$

<sup>1</sup> H. Moore, Proc. Roy. Soc. **91**, 337 (1915).

<sup>2</sup> J. J. Thomson, "Conduction of Electricity through Gases," 2d Ed., p. 378.

But the time of interaction  $\tau$  is inversely proportional to the velocity  $V$  of the beta particle, i.e.,  $\tau = A/V$ , whence

$$\epsilon = \frac{V^2 \cdot A^2}{2mV^2} = B/mV^2. \quad (8-38)$$

In each unit path there will be several collisions, for each of which the energy imparted is proportional to  $1/mV^2$ , whence the energy lost per unit path is also proportional to  $1/mV^2$ . That is,

$$-\frac{dT}{dx} = \frac{C}{mV^2},$$

where  $T$  is the kinetic energy of the beta particle and  $C$  is a new constant of proportionality. We may write approximately (for low velocities)  $T = \frac{1}{2}mV^2$ , and we have

$$TdT = -2Cdx,$$

which when integrated may be put in the form

$$T_x^2 = T_0^2 - bx, \quad (8.39)$$

or

$$V_x^4 = V_0^4 - ax, \quad (8.40)$$

where  $a$  and  $b$  are constants depending upon the number of electrons per unit volume in the material traversed. If the final velocity  $V_x$  is zero, we thus have for the range of the beta particle

$$x = V_0^4/a. \quad (8.41)$$

Equations (8.40) and (8.41) have been tested experimentally for beta rays of moderate speed by Whiddington,<sup>1</sup> Wilson,<sup>2</sup> and others,<sup>3</sup> who find them accurate within experimental error. Of course  $x$  must be measured along the path of the particle. The actual thickness of matter traversed is considerably less than the length of the path. Terrill<sup>3</sup> finds the value of the constant  $a$  for various metals to be as follows:

<sup>1</sup> R. Whiddington, Proc. Roy. Soc. **86**, 360 (1912).

<sup>2</sup> C. T. R. Wilson, Proc. Roy. Soc. **104**, 1 (1923).

<sup>3</sup> B. F. J. Shonland, Proc. Roy. Soc. **104**, 235 (1923). H. M. Terrill, Phys. Rev. **21**, 476 (1923); **22**, 107 (1923).

TABLE VIII-3  
VALUES OF THOMSON-WHIDDINGTON CONSTANT  $a$

Substance	Obs. (Terrill)	Calc. (Bohr, approx.)
Beryllium.....	$.94 \times 10^{43}$	$1.1 \times 10^{43}$
Aluminium.....	1.4	1.7
Copper.....	4.5	5.3
Silver.....	5.3	5.9
Gold.....	11.2	10
Density $\rho$ .....	$.505\rho$	$.6\rho$

These constants are approximately proportional to the densities of the metals, as should obviously be the case according to Thomson's theory.

Wilson has found that in moist air at 760 mm. and 18° C. an electron that has fallen through 21,000 volts has a range of 1 cm. From this it follows that for air,  $a = 5.5 \times 10^{-39}$ .

In Thomson's theory no account is taken of the motion or the binding forces on the electrons which are set in motion. This has been considered in detail, however, by Bohr,<sup>1</sup> who obtains an expression for the constant  $a$  which depends upon the characteristic (critical ionization) frequencies of the electrons in the atom. Bohr's formula may be written in the form:<sup>2</sup>

$$a = \frac{16\pi e^4 n}{m^2} \sum_1^Z \log \left( \frac{kV^3 m}{4\pi \nu_i e^2} \right), \quad (8.42)$$

where  $n$  is the number of atoms per unit volume,  $V$  is the velocity of the beta particle,  $\nu_i$  is the critical ionization frequency of the  $i$ th electron in the atom,  $k = 1.1$ , and  $Z$  is the atomic number. This may be written,

$$a = \frac{16\pi e^4 N}{m^2} \cdot \frac{n}{N} Zl = 1.96 \times 10^{42} \frac{n}{N} Zl, \quad (8.43)$$

where  $N$  is the number of molecules per gram molecules and  $l \equiv \log (kV^3 m / 4\pi \nu_i e^2)$ . Since it is a logarithm,  $l$  varies only

<sup>1</sup> N. Bohr, Phil. Mag. 25, 10 (1913); 30, 581 (1915).

<sup>2</sup> Cf. H. A. Kramers, Phil. Mag. 46, 868 (1923).

slightly with  $V$  and  $\nu_i$ . Thus, assuming  $\bar{\nu}_i = 10^{17}$ , if  $V$  corresponds to a potential of 10 kilovolts  $l = 6.6$ , while for  $V$  corresponding to 5 kilovolts  $l = 5.6$ . Hence  $a$  should be almost though not quite constant. In Table VIII-3 are shown the values of  $a$  thus calculated (taking  $l = 6.6$ ) compared with Terrill's experimental values. The agreement is rather satisfactory.

For beta rays whose velocity is so great that the kinetic energy is no longer given by  $\frac{1}{2}mV^2$  the range should, according to the ideas underlying the theory, increase more rapidly than stated by equation (8.41). The range should instead approach infinity as  $V$  approaches  $c$ .

### 117. Ionization due to Beta Rays

The cloud expansion photographs show that the ionization is more intense near the end of the track where the beta ray is moving slowly than along the initial portions of the track. This is in accord with equation (8.38), according to which the energy spent per unit path of the beta ray is inversely proportional to  $1/V^2$ . Since  $V$  cannot exceed  $c$ , the ionization per unit length of path does not approach zero even for the fastest beta rays. For this reason even the highest speed beta rays produce a visible track in the cloud expansion chamber.<sup>1</sup>

Theories by Thomson,<sup>2</sup> Bohr,<sup>3</sup> and Rosseland<sup>4</sup> of the ionization by beta rays are based on a calculation of the probability that a collision with an electron will give it energy greater than enough to remove it from the atom. Thomson's expression for the number of ions produced directly by the beta ray per unit path is

$$I = \frac{2\pi nZe^4}{mV^2W}, \quad (8.44)$$

<sup>1</sup> If the velocity of the beta particle is within a few meters per second of the velocity of light, radiation reactions become important, and the beta particle may produce no ions (cf. W. F. G. Swann, *Phil. Mag.* **47**, 306, (1924)). The energy of such particles is large, however, compared with even the fastest beta rays emitted by radioactive substances.

<sup>2</sup> J. J. Thomson, *Phil. Mag.* **23**, 449 (1912).

<sup>3</sup> N. Bohr, *Phil. Mag.* **30**, 581 (1915).

<sup>4</sup> S. Rosseland, *Phil. Mag.* **45**, 65 (1923).

where as before  $n$  is the number of atoms per unit volume,  $Z$  the atomic number, and  $W$  the energy required to free the electron. This expression agrees with those of Bohr and Rosse-land.

Wilson finds<sup>1</sup> that if  $V = 10^{10}$  cm./sec., a beta particle traversing moist air at 760 mm. and 20° C. ejects about 90 electrons per centimeter of its path. From this he calculates that  $W$  of equation (8.44) must correspond to about 7 volts. This value is less than half of the ionizing potential of oxygen and nitrogen as given by recent work, and is nearly equal to the "radiating" potential. Thus we cannot feel satisfied with the status of the theories designed to account for the ionization by high speed beta particles.

### 118. *Form of Beta Ray Tracks*

From a study of the electrom tracks photographed with his expansion apparatus, C. T. R. Wilson found, "The rays show two distinct kinds of deflection as a result of their encounters with the atoms of the gas—Rutherford's 'single' and 'compound' scattering. The gradual or cumulative deviation due to successive deflections of a very small amount is evidently, however, in this case much the more important factor in causing scattering, all the rays showing a large amount of curvature, while quite a small proportion show abrupt bends. When abrupt deflections occur they are frequently through large angles, 90° or more."<sup>2</sup>

In a later study<sup>3</sup> he distinguishes between abrupt deflections which result in a branched track, and are thus probably due to a collision with another electron, and nuclear collisions which result in no branches. From the number of nuclear deflections through an angle greater than 90 degrees he calculates according to Rutherford's theory of scattering<sup>4</sup> that the

<sup>1</sup> C. T. R. Wilson, Proc. Roy. Soc. 104, 192 (1923).

<sup>2</sup> C. T. R. Wilson, Proc. Roy. Soc. 87, 289 (1912).

<sup>3</sup> C. T. R. Wilson, Proc. Roy. Soc. 104, 205 (1923).

<sup>4</sup> E. Rutherford, Phil. Mag. 21, 668 (1911).

charge of the nucleus with which the collision occurs is  $6.5e$ , which is very near the charge  $7e$  of the nitrogen nucleus.

Many people have noticed that the photographs of the beta ray tracks seem to show a nearly uniform curvature<sup>1</sup> over distances greater than is to be expected if the deflections are fortuitous. The tracks sometimes appear to have the form of converging helices,<sup>2</sup> such as might be due to a motion in a strong magnetic field. None of the explanations of this effect, however, have seemed to be satisfactory,<sup>3</sup> and considerable doubt as to the reality of the phenomenon has been raised by Bothe.<sup>4</sup>

<sup>1</sup> C. T. R. Wilson, Proc. Roy. Soc. **104**, 206 (1923).

<sup>2</sup> A. H. Compton, Phil. Mag. **41**, 279 (1921).

<sup>3</sup> Explanations have been suggested by T. Shimizu and A. H. Compton, Phil. Mag. **41**, 279 (1921); J. L. Glasson, Nature, **108**, 421 (1921); C. T. R. Wilson, Proc. Roy. Soc. **104**, 208 (1923). These have been criticized by P. L. Kapitza, Proc. Camb. Phil. Soc. **21**, 129 (1922), and A. H. Compton, Bulletin Nat. Res. Council No. **20**, p. 30 (1922).

<sup>4</sup> W. Bothe, Zeits. f. Physik, **12**, 117 (1923).

## CHAPTER IX

### QUANTUM THEORY OF X-RAY SCATTERING

#### 119. *Scattered X-rays as Directed Quanta Instead of Waves*

In the discussion of the scattering of X-rays given in Chapter III, we found that many of the properties of the scattered rays could be accounted for on the basis of the classical theory as developed by Thomson and extended by Debye. The accuracy of Barkla's determination, from scattering experiments, of the number of electrons in an atom, and the success in extending the theory to cover the diffraction of X-rays by crystals, led physicists to class scattering phenomena with those of interference and refraction as completely explicable according to our classical ideas of electrons and electromagnetic waves. Within the last few years, however, new scattering phenomena have been observed which are so directly contrary to the usual electro-dynamics that we have been compelled to reverse our attitude almost completely. Far from explaining the scattering of X-rays on the assumption that radiation spreads in all directions as spherical waves, we seem driven by the recent experiments to consider X-rays as definitely directed quanta of radiant energy.

The evidence leading to this dramatic reversal of our ideas of the nature of X-rays—and hence of all radiation—will be presented in the first part of this chapter. In the latter part we shall consider the application of the quantum theory to such problems as the intensity of X-ray scattering, for which unique solutions have not as yet been found.

#### I. THE CHANGE OF WAVE-LENGTH OF SCATTERED X-RAYS

##### 120. *Early Experiments*

The earliest experiments on secondary X-rays and  $\gamma$ -rays showed a difference in the penetrating power of the primary

and the secondary rays.<sup>1</sup> In the case of X-rays, Barkla and his collaborators showed that the secondary rays from the heavy elements consisted largely of fluorescent radiations characteristic of the radiating element, and that it was the presence of these softer rays which was chiefly responsible for the greater absorption of the secondary rays.<sup>2</sup> When later experiments showed a measurable difference in penetration even for light elements such as carbon, from which no fluorescent *K* or *L* radiation appears, it was only natural to ascribe this difference to a new type of fluorescent radiation, similar to the *K* and *L* types, but of shorter wave-length.<sup>3</sup> Careful absorption measurements failed however to reveal any critical absorption limit for these assumed "J" radiations similar to those corresponding to the *K* and *L* radiations. Moreover, direct spectroscopic ob-

<sup>1</sup> For  $\gamma$ -rays, see A. S. Eve, *Phil. Mag.* **8**, 669 (1904); R. D. Kleeman, *Phil. Mag.* **15**, 638 (1908); J. P. V. Madsen, *Phil. Mag.* **17**, 423 (1909); D. C. H. Florance, *Phil. Mag.* **20**, 921 (1910); J. A. Gray, *Phil. Mag.* **26**, 611 (1913); D. C. H. Florance, *Phil. Mag.* **27**, 225 (1914); K. W. F. Kohlrausch, *Phys. Zeit.* **21**, 193 (1920); A. H. Compton, *Phil. Mag.* **41**, 749 (1921); et al.

In the case of X-rays scattered by light elements, the early experiments of Barkla and his collaborators indicated a slight softening of the secondary rays (C. G. Barkla, *Phil. Mag.* **7**, 550, 1904; R. T. Beatty, *Phil. Mag.* **14**, 604, 1907), but the difference seems to have been considered within the experimental error: "the scattered radiation differs inappreciably in penetrating power from the primary radiation, that is to say, there is no appreciable degradation<sup>4</sup> accompanying the process of scattering" (Barkla and Miss Ayers, *Phil. Mag.* **21**, 271, 1911). Experiments showing the softening of secondary X-rays have been performed by C. A. Sadler and P. Mesham, *Phil. Mag.* **24**, 138 (1912); J. Laub, *Ann. der Phys.* **46**, 785 (1915); J. A. Gray, *Franklin Inst. J.* Nov. 1920, p. 643; A. H. Compton, *Phys. Rev.* **18**, 96 (1921); *Nature*, **108**, 366 (1921); J. A. Crowther, *Phil. Mag.* **42**, 719 (1921).

<sup>2</sup> C. G. Barkla and C. A. Sadler, *Phil. Mag.* **16**, 550 (1908).

<sup>3</sup> J. Laub, *Ann. der Phys.* **46**, 785 (1915); J. A. Crowther, *Phil. Mag.* **42**, 719 (1921).

Barkla's "J-transformation" is an interpretation of the softening of secondary X-rays which is essentially different from that of fluorescence. It is supposed rather that the rays are scattered without change of wave-length, but are in some way modified as they traverse matter after being scattered. This suggestion has been developed in the following papers:

C. G. Barkla and R. Sale, *Phil. Mag.* **45**, 748 (1923); C. G. Barkla and S. R. Khastgir, *Phil. Mag.* **49**, 251 and **50**, 1113 (1925); C. G. Barkla, *Nature*, **112**, 723 (1923); Feb. 13, 1926.

For discussion of the "J-transformation," see A. H. Compton, *Nature*, **113**, 160 (1924); R. T. Dunbar, *Phil. Mag.* **49**, 210 (1925), and J. A. Gray, *Bull. Am. Phys. Soc.* **1**, No. 7, p. 15 (1926).

servations failed to reveal the existence of any spectrum lines under conditions for which the supposed J rays should appear.<sup>1</sup> It thus became evident that the softening of the secondary X-rays from the lighter elements was due to a different kind of process than the softening of the secondary rays from heavy elements where fluorescent X-rays are present.

It was at this stage that the first spectroscopic investigations of the secondary X-rays from light elements were made.<sup>2</sup>

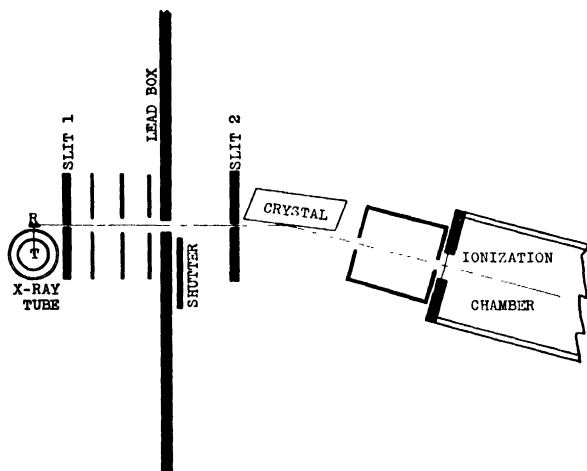

FIG. 107.

According to the usual electron theory of scattering it is obvious that the scattered rays will be of the same frequency as the forced oscillations of the electrons which emit them, and hence will be identical in frequency with the primary waves which set the electrons in motion. Instead of showing scattered rays of the same wave-length as the primary rays, however, these spectra revealed lines in the secondary rays corresponding to those in the primary beam but with each line displaced slightly toward the longer wave-lengths.

A diagram of the apparatus employed, such as Fig. 107,

<sup>1</sup> See p. 188.

<sup>2</sup> A. H. Compton, Bulletin Nat. Res. Council. No. 20, p. 16 (1922); Phys. Rev. 21, 715 and 22, 409 (1923).

may help in understanding the significance of the result. X-rays proceed from the molybdenum target  $T$  of the X-ray tube to the carbon radiator  $R$ , and are thence scattered at an angle  $\phi$  with the primary beam through the slits 1 and 2 to the crystal of a Bragg spectrometer. Thus is measured the wave-length of the X-rays that have been scattered at an angle  $\phi$ . This angle may be altered by shifting the radiator and the X-ray tube, and the spectrum of the primary beam may be obtained by merely shifting the X-ray tube without altering the slits or the crystal.

Spectra of the molybdenum  $K\alpha$  line after being scattered by carbon at different angles are shown in Fig. 108. The upper curve is the spectrum of the primary ray, and the curves below are the spectra, using the same slits, of the rays scattered at 45 degrees, 90 degrees and 135 degrees respectively. It will be seen that though in each case there is one line of exactly the same wave-length as the primary, there also occurs a second line of greater wave-length. These spectra show not only that the wave-length of the secondary ray differs from that of the primary, but also the fact that the difference increases rapidly at large angles of scattering.

In Fig. 110 is shown a similar spectrum of X-rays scattered at  $120^\circ$  by lithium, in which no appreciable line appears of the same wave-length as the primary beam.<sup>1</sup> We have seen (p. 61) that the energy of the whole secondary X radiation from light elements is very nearly equal to that calculated from

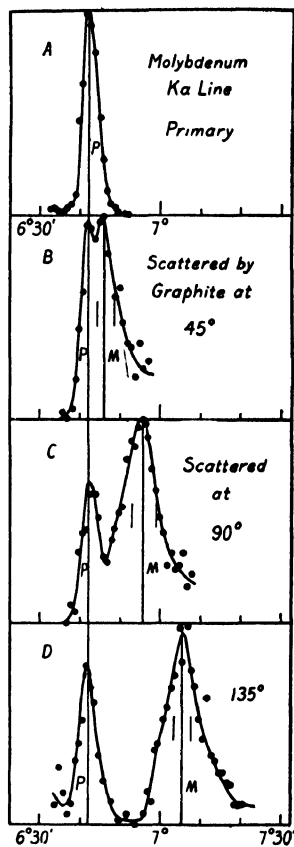

FIG. 108.

<sup>1</sup> Y. H. Woo, Phys. Rev. 27, 119 (1926).

Thomson's classical theory for the scattered rays. If there is any scattering from lithium it must therefore be the radiation which appears in the spectrum as the shifted line *M*. Similarly we must ascribe both lines in the spectrum of the secondary rays from carbon to scattered X-rays.<sup>1</sup>

The fact that the scattered rays are of greater wave-length when scattered at large angles with the primary beam suggests at once a Doppler effect as from particles moving in the direction of the primary radiation. This would be similar to the change in wave-length of the Fraunhofer lines in the sunlight reflected to us by Venus, because of the Doppler effect from the motion of the planet. According to the classical idea of the scattering process, however, every electron in the matter traversed by the primary X-rays is effective in scattering the rays. In order to account for such a Doppler effect on this view, therefore, all of the electrons in the radiating matter would have to be moving in the direction of the primary beam with a velocity comparable with that of light—an assumption obviously contrary to fact. It is clear that if any electrons move in this manner it can be only a very small fraction of the whole number in the scattering material, and that it must be this small fraction which is responsible for the scattering. The idea thus presents itself that an electron, if it scatters at all, scatters a complete quantum of the incident radiation; for thus the number of electrons which move forward would just be equal to the number of scattered quanta.

<sup>1</sup> The view has occasionally been defended that the shifted or modified line is due to a form of fluorescent radiation (A. H. Compton, *Phil. Mag.* **41**, 749, 1921; *Phys. Rev.* **18**, 96, 1921) or tertiary *X* radiation produced by the impact of photoelectrons (G. L. Clark and W. Duane, *Proc. Nat. Acad. Sci.* **9**, 422, 1923 and later papers). This hypothesis suggests no reason why the energy in the modified rays from lithium should be that calculated on Thomson's theory of the scattered rays. It also fails to account for the fact that the secondary X-rays at 90° are completely polarized (cf. p. 68)—a property characteristic of scattered rays.

In applying the name "scattered rays" to those here studied, we mean the rays which correspond most closely to those described by Thomson's original theory of scattering.

121. *Theory of Quanta Scattered by Free Electrons*<sup>1</sup>

This suggestion that each quantum of X-rays is scattered by a single electron supplies a simple means of accounting for the observed change of wave-length. For if we consider the primary rays to proceed in quanta so definitely directed that they can be scattered by individual electrons, along with their energy  $h\nu$  they will carry<sup>2</sup> momentum  $h\nu/c$ . The scattered quantum, however, proceeding in a different direction from the primary, carries with it a different momentum. Thus by the principle of the conservation of momentum, the electron which scatters the ray must recoil with a momentum equal to the vector difference between that of the primary and that of the scattered quantum (Fig. 109). But the energy of this recoiling

<sup>1</sup> A. H. Compton, Bulletin Nat. Res. Council No. 20, p. 19 (1922); Phys. Rev. 21, 207 and 483 (1923). P. Debye, Phys. Zeits. 24, 161 (1923).

A difficulty presents itself when we consider the action of radiation quanta on free electrons. In the last chapter we supposed that when a quantum acts on an electron in an atom it gives to the system both its energy  $h\nu$  and its momentum  $h\nu/c$  (eq. 8 06—8 09), and found that the photoelectric effect was thus rather adequately described. But if a quantum gives to a free electron its momentum,

$$\frac{h\nu}{c} = \frac{m\beta c}{\sqrt{1 - \beta^2}}, \quad (1)$$

it cannot at the same time give to the electron its energy, for which we should have

$$h\nu = mc^2 \left( \frac{1}{\sqrt{1 - \beta^2}} - 1 \right). \quad (2)$$

That is, if a quantum were to give its energy to a free electron, the momentum of the system could not be conserved. If then we adhere to the principles of the conservation of energy and momentum, it is impossible for a radiation quantum to impart its energy to a free electron. In other words, there can be no photo-electric effect with free electrons. This is in accord with Moore's observation (p. 254) that the number of photoelectrons produced per atom in an element of atomic number  $Z$  is proportional to  $Z^1$ , since for free electrons  $Z = 0$ .

Since equations (1) and (2) cannot be simultaneously satisfied, we might infer that a quantum could not affect a free electron. The possibility remains, however, of supposing that *only a part of the quantum's energy is spent on the electron*, the remainder escaping as a radiation quantum of less energy. It is this possibility which is developed in this chapter, and is found consistent with the energy and momentum principles.

<sup>2</sup> Cf. equation 25 of Appendix I.

electron is taken from that of the primary quantum, leaving a scattered quantum which has less energy and hence a lower frequency than has the primary quantum.

From the principle of the conservation of energy we have

$$h\nu = h\nu' + mc^2 \left( \frac{1}{\sqrt{1 - \beta^2}} - 1 \right), \quad (9.01)$$

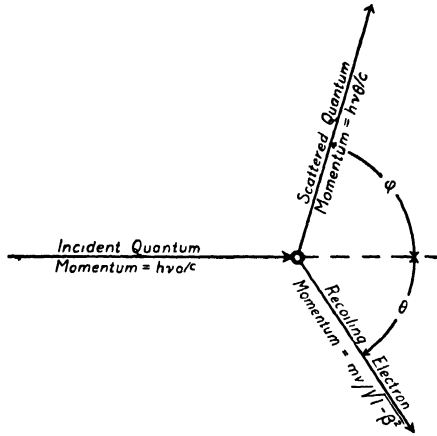

FIG. 109.

where  $\nu$  is the frequency of the incident ray,  $\nu'$  that of the ray scattered by the electron, and  $mc^2 \left( \frac{1}{\sqrt{1 - \beta^2}} - 1 \right)$  is the kinetic energy of the recoiling electron.<sup>3</sup> The principle of conservation of momentum supplies the additional equations,

$$\text{(X-component)} \quad \frac{h\nu}{c} = \frac{h\nu'}{c} \cos \phi + \frac{m\beta c}{\sqrt{1 - \beta^2}} \cos \theta \quad (9.02)$$

$$\text{(Y-component)} \quad 0 = \frac{h\nu'}{c} \sin \phi + \frac{m\beta c}{\sqrt{1 - \beta^2}} \sin \theta \quad (9.03)$$

For a definite angle of scattering  $\phi$  there are in these equations three unknown quantities,  $\nu'$ ,  $\beta$  and  $\theta$ , the angle of recoil of the electron. By a straightforward solution of the three

<sup>3</sup> Cf. equation 21 of Appendix II.

equations we can calculate these quantities. It is more convenient, however, to express the result in terms of the scattered wave-length  $\lambda' = c/\nu'$ , and the kinetic energy of the recoiling electron. We obtain,<sup>1</sup>

$$\lambda' = \lambda + \frac{h}{mc}(1 - \cos \phi),$$

or

$$\left. \begin{aligned} \delta\lambda &= \lambda' - \lambda = \frac{h}{mc}(1 - \cos \phi) \\ &= \gamma \text{ vers } \phi, \end{aligned} \right\} \quad (9.04)$$

where  $\gamma = h/mc = .0243\text{\AA}$ , and  $\text{vers } \phi = 1 - \cos \phi$ . Also

$$\left. \begin{aligned} E_{\text{kin}} &= h\nu \cdot \frac{\alpha \text{ vers } \phi}{1 + \alpha \text{ vers } \phi} \\ &= h\nu \cdot \frac{2\alpha \cos^2 \theta}{(1 + \alpha)^2 - \alpha^2 \cos^2 \theta} \end{aligned} \right\} \quad (9.05)$$

and

$$\cot \theta = - (1 + \alpha) \tan \frac{1}{2} \phi,$$

or

$$\cot \frac{1}{2} \phi = - (1 + \alpha) \tan \theta, \quad (9.06)$$

where

$$\alpha \equiv h\nu/mc^2 = \gamma/\lambda.$$

Equations (9.04) predict that the scattered ray should be of greater wave-length than its parent primary ray, and that this increase in wave-length should be greater at large scattering angles. The wave-length change should however be the same for short wave-length as for great wave-length primary rays, and should be the same for all substances. According to equations (9.05) there should exist a type of  $\beta$ -ray with energy less than  $h\nu$  by a factor of approximately  $2\alpha \cos^2 \theta$ . For all except very hard X-rays, these  $\beta$ -rays must thus possess much less energy than the photoelectrons described in the last chapter. They should also always proceed at angles less than 90 degrees, and those at the smaller angles should have the greater energy. It follows from equations (9.06) that for each electron ejected at

<sup>1</sup> Cf. Appendix VI.

an angle  $\theta$  there should be a quantum of X-rays scattered in a definite direction  $\phi$ . This is in sharp contrast with the classical electromagnetic theory, according to which the energy should be radiated in all directions. All of these predictions are subject to experimental test.

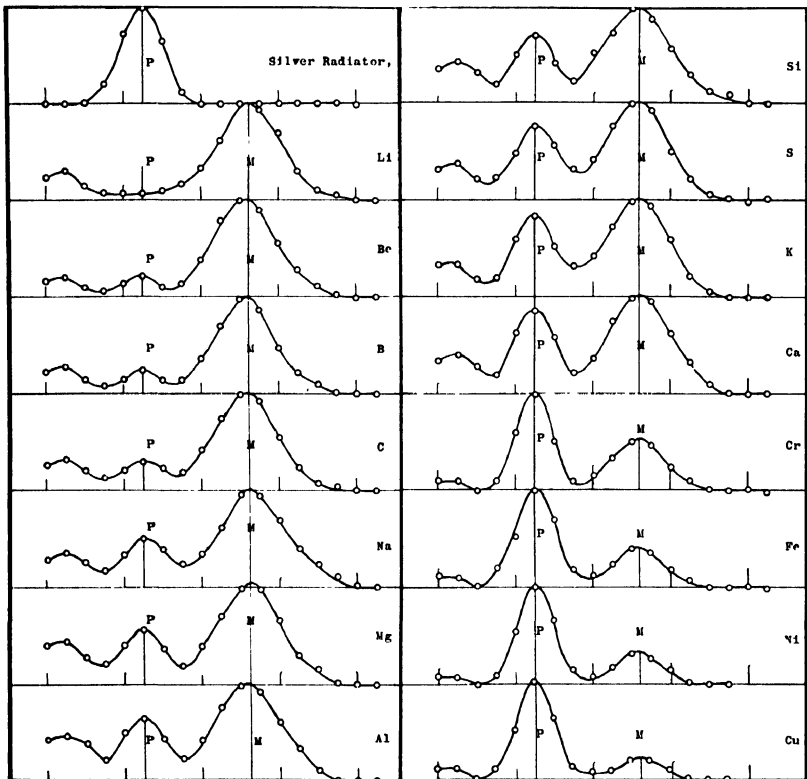

FIG. 110.

### 122. Measurements of the Change of Wave-length Accompanying the Scattering of X-rays

In Fig. 108 the line  $M$  is calculated in each case from the theoretical formula for the change in wave-length. That it is not accidental that for carbon the agreement with the theory is so satisfactory is evident from the spectra shown in Fig. 110,

which shows similar spectra from many different scattering elements, recently obtained by Dr. Woo.

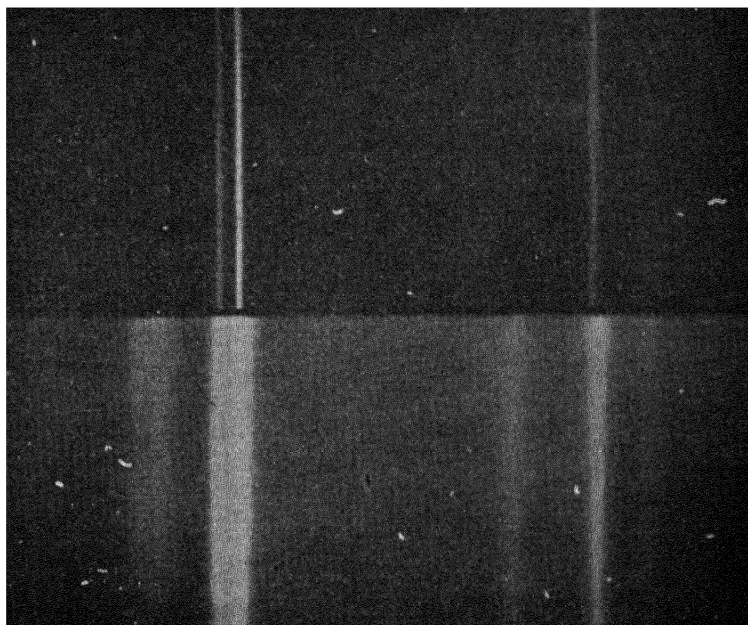

FIG. 111.

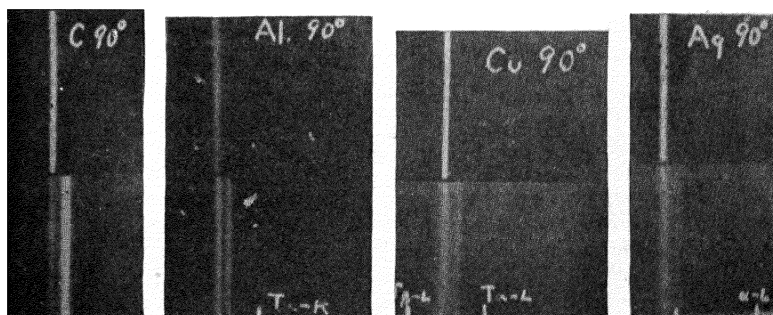

FIG. 112.

These ionization spectra are completely confirmed by photographic spectra. Fig. 111 shows a beautiful photographic spec-

trum obtained by P. A. Ross, which compares the spectrum of the  $K$  series lines from molybdenum with the spectrum of these rays after being scattered at 90 degrees by aluminium. One sees distinctly the  $\alpha_1$ ,  $\alpha_2$ ,  $\beta$  and  $\gamma$  lines as both shifted and unshifted lines. In Fig. 112 are shown a series of Ross's photographic spectra of the molybdenum  $K\alpha$  ray scattered by carbon, aluminium, copper and silver.<sup>1</sup> This figure shows in a striking manner the fact that the shift is independent of the scattering material.

~ Though in the experiments just cited the magnitude of the change in wave-length agrees satisfactorily with the theoretical value,<sup>2</sup> the precision of the experiments was not greater than

<sup>1</sup> P. A. Ross, Proc. Nat. Acad. **10**, 304 (1924).

<sup>2</sup> Not all of the measurements of the wave-length of scattered X-rays have given such satisfactory results. Especially disturbing for about a year was a series of experiments performed by various investigators at Harvard in which instead of the effect here described a different effect, called "tertiary radiation," was observed. See: G. L. Clark and W. Duane, Proc. Nat. Acad. **9**, 413 and 419 (1923); **10**, 41 and 92 (1924). G. L. Clark, W. Duane and W. W. Stifler, *ibid.* **10**, 148 (1924). S. K. Allison and W. Duane, *ibid.* **10**, 196 (1924). A. H. Armstrong, W. Duane and W. W. Stifler, *ibid.* **10**, 374, (1924). S. K. Allison, G. L. Clark and W. Duane, *ibid.* **10**, 379 (1924).

"The tertiary radiation" was never definitely observed by other investigators than those at Harvard (though suspected by some, e.g., J. A. Becker, *Ibid.* **10**, 342 (1924). Experiments showing the type of spectrum described above have been performed by: A. H. Compton, Bulletin National Research Council, No. 20, p. 15 (1922); Phys. Rev. **21**, 207, 483 and 715 (1923); **22**, 409 (1923); Phil. Mag. **46**, 897 (1923). A. H. Compton and Y. H. Woo, Proc. Nat. Acad. **10**, 271 (1924). A. H. Compton and J. A. Bearden, Proc. Nat. Acad. **11**, 117 (1925). P. A. Ross, Proc. Nat. Acad. **9**, 246 (1923); **10**, 304 (1924); Phys. Rev. **22**, 524 (1923). P. A. Ross and D. I. Webster, Proc. Nat. Acad. **11**, 56 (1925). B. Davis, Paper before the A. A. A. S. Dec. 28, 1923. J. A. Becker, Proc. Nat. Acad. **10**, 342 (1924). A. Müller, cf. W. H. and W. L. Bragg, X-Rays and Crystal Structure (1924) p. 297. M. de Broglie, Comptes Rendus, **178**, 908 (1924). A. Davillier, Comptes Rendus, **178**, 2076 (1924). M. de Broglie and A. Davillier, *ibid.* **179**, 11 (1924); J. de Physique, **6**, 369 (1925). S. K. Allison and W. Duane, Proc. Nat. Acad. **11**, 25 (1925); Phys. Rev. **26**, 300 (1925). H. Kallman and H. Mark, Naturwiss. **13**, 297 (1925). Y. H. Woo, Proc. Nat. Acad. **11**, 123 (1925). H. M. Sharp, Phys. Rev. **26**, 691 (1925).

In the latest experiments of Allison and Duane (*loc. cit.*) at Harvard they also fail to find the tertiary radiation and observe only the usual shift predicted by the quantum theory.

It appears that the experiments which led to the suggestion of the tertiary radiation were affected by an unfortunate combination of errors which produced spurious spectral lines. In many of the earlier Harvard experiments rays scattered over a wide

2 or 3 per cent. In order to make an exact test of the wave-length equation, it is necessary to scatter the X-rays at a definite and known angle  $\phi$ , as well as to measure precisely the change in wave-length. Perhaps the best experiment of this character is that of Sharp,<sup>1</sup> in which the rays were scattered almost directly backward, at an angle of  $\phi = 169^\circ$ . Thus not only was  $\delta\lambda$  made a maximum, but also the value of  $\text{vers } \phi$  was near a maximum and could change only slowly with variations in  $\phi$ . The spectrum was examined by a special form of photographic spectrometer, and was analyzed with the help of a microphotometer. It was found that the modified (shifted) line was broader than the unmodified line,<sup>2</sup> and the measurement was made to the peak of the line, with the result,

$$\delta\lambda_{169^\circ} = 0.04825 \pm .00017\text{A.}$$

It follows that

$$h/mc_{\text{c.mpt.}} = 0.02432 \pm .00009\text{A.} \quad (9.07)$$

If we take Duane's value of  $h = 6.556 \times 10^{-27}$  erg sec. and  $c = 2.9986 \times 10^{10}$  cm/sec., the theoretical magnitude of  $h/mc$  varies with the value assigned to  $m$ . Thus on the basis of Babcock's determination<sup>3</sup> of  $e/m = 1.761 \times 10^7$  e.m.u. from measurements of the Zeeman effect, we have

$$m = e/(e/m) = 9.04 \times 10^{-28}\text{g,}$$

range of angles  $\phi$  entered the X-ray spectrometer, so that the shifted rays were spread out into a broad, faint band instead of a sharp line. In the experiments with aluminium an impurity seems to have been present which gave a sharp line at the position in which the tertiary peak was anticipated. It is probable also that stray X-rays may have affected some of the readings. After precautions were taken to remove these sources of trouble, the Harvard apparatus gave some of the best measurements of the spectral shift that have been made (Allison and Duane's experiments, loc. cit.).

I believe it is agreed by all who have followed these experiments that there remains no evidence whatever for the existence of the supposed tertiary radiation. On the other hand, the evidence indicates that the wave-length change is given accurately by the quantum formula, and that the ratio of the intensities of the modified and unmodified lines depends only on the wave-length, the scattering material, and the angle of scattering.

<sup>1</sup> H. M. Sharp, *Phys. Rev.* **26**, 691 (1925).

<sup>2</sup> This fact had previously been noted by A. H. Compton, *Phys. Rev.* **22**, 409 (1923), S. K. Allison and W. Duane, *Phys. Rev.* **26**, 300 (1925); et al.

<sup>3</sup> H. D. Babcock, *Astrophys. J.* **58**, 149 (1923).

and

$$h/mc_1 = 0.02418\text{A}.$$

But if we take the value of  $e/m = 1.773 \times 10^7$  e.m.u., which Birge finds<sup>3</sup> as an average of the magnetic deflection determinations, we have  $m = 8.98 \times 10^{-28}$  g, and

$$h/mc_2 = 0.02435\text{A}.$$

It is probable from recent theoretical work on the Zeeman effect that Babcock's value of  $e/m$  is too low. In any case, it is clear from these experiments that the quantum formula (9.04) for the change of wave-length is as accurate as our knowledge of the constants  $h$ ,  $m$  and  $c$ .

### 123. *The Unmodified Line*

The simple theory outlined above accounts only for the existence of the line whose wave-length is modified. This is doubtless because we have considered only the interaction between quanta and electrons that are free. If an electron is so firmly bound within the atom that the impulse imparted by the quantum is insufficient to eject it, the atom in its final condition has the same energy as in the beginning, so that no energy is removed from the quantum. For the light atoms, in which all the electrons are loosely bound, the modified line should thus be relatively intense, whereas for the heavy atoms, in which most of the electrons are firmly held, the unmodified ray should have the greater energy. This is precisely what is shown by the figures reproduced above.

From this explanation of the unmodified line it would also follow that for ordinary light, for which the impulse imparted by a quantum is far too small to eject even the most loosely bound electron, all the energy should lie in the unmodified line. On the other hand, for  $\gamma$ -rays the impulse would be so great that almost every electron would be ejected, so that nearly all the scattered rays should be modified. This agrees exactly with Ross's observation that the light rays scattered by paraffin are

<sup>3</sup> R. T. Birge, *Phys. Rev.* 14, 262 (1919).

unmodified,<sup>1</sup> and the author's observation that there is no detectable scattered  $\gamma$ -radiation having the original wavelength.<sup>2</sup>

#### 124. *Recoil Electrons*

From the quantitative agreement between the theoretical and the observed wave-lengths of the scattered rays, we may look with some confidence for the recoil electrons which are predicted by the quantum theory of scattering. At the time that this theory was proposed there was no direct evidence for the existence of such electrons, though indirect evidence suggested<sup>3</sup> that the secondary beta rays ejected from matter by hard  $\gamma$ -rays are mostly of this type. Within a few months of their prediction, however, two investigators, C. T. R. Wilson<sup>4</sup> at Cambridge and W. Bothe<sup>5</sup> at Charlottenburg independently announced their discovery.

Photographs of the trails of these recoil electrons have been shown in Figs. 95, 96 and 97. It is the tracks of the shorter type in Figs. 95 and 96 that Wilson identified with the recoil electrons, and all those in Fig. 97 are of this kind. It will be seen that for the harder X-rays the tracks increase in number and in length and develop "tails" on the side of the incident X-rays. For this reason Wilson dubbed them "fish" tracks. It is a significant characteristic that all the "fishes" have their heads pointed in the direction of the incident X-ray beam, as is to be expected if they are due to recoil electrons. It will be seen also that the tracks which start directly forward are usually longer than those that move at an angle with the primary ray, corresponding to the difference in energy at different angles as predicted by equation (9.05).

<sup>1</sup> P. A. Ross, *Science*, **57**, 614 (1923).

<sup>2</sup> A. H. Compton, *Phil. Mag.* **41**, 760 (1921).

<sup>3</sup> A. H. Compton, *Bulletin Nat. Res. Coun. No. 20*, p. 27 (1922).

<sup>4</sup> C. T. R. Wilson, *Proc. Roy. Soc.* **104**, 1 (1923).

<sup>5</sup> W. Bothe, *Zeits. f. Phys.* **16**, 319 (1923). In this paper, not being aware of the prediction of the recoil electrons, Bothe ascribed his newly discovered rays to  $H$  particles. Soon afterward he showed that they had the characteristics of the predicted recoil electrons, *Zeits. f. Phys.* **20**, 237 (1923).

Probably the most convincing reason for associating these short tracks with the scattered X-rays comes from a study of their number. In the last chapter we saw that each track of the long kind is produced by a photoelectron, and represents a quantum of truly absorbed energy. If the short tracks are due to recoil electrons, each one should represent the scattering of a quantum. Thus if  $\sigma/\tau$  is the ratio of the energy scattered to that truly absorbed (see Chapter VI), we should have  $\sigma/\tau = N_R/N_P$ , where  $N_R$  is the number of short tracks and  $N_P$  the number of long tracks observed in the cloud expansion photographs.

An actual count of these numbers gave <sup>1</sup> the results shown in Table IX-I. Only those tracks were counted in the 3rd and

TABLE IX-I  
NUMBER OF TRACKS OF TYPES *R* AND *P*

Effective Wave-length	Total Tracks	<i>R</i> Tracks, $N_R$	<i>P</i> TRACKS, $N_P$	$\frac{N_R}{N_P}$	$\frac{\sigma}{\tau}$
.71A	58	5	49	0 10	0 27
.44	24	10	11	0 9	1 2
.29	46	33	12	2 7	3 8
.20	84	74	8	9	10
.17	73	68	4	17	17
.13	79	72	1	72	32

4th columns whose character could be distinguished with considerable certainty. For the shortest wave-length the recoil tracks were so long that it was impossible to distinguish in some cases whether a given track was an *R* or a *P* track. Similarly for the longest waves it was hard to tell an *R* track from a "sphere" track produced by the secondary *K* radiation from oxygen, nitrogen and argon. The values of  $\sigma$  and  $\tau$  are calculated from the absorption coefficients in air, remembering that  $\tau$  is proportional to  $\lambda^3$  (p. 192). Even for the extreme wave-lengths the agreement between  $N_R/N_P$  and  $\sigma/\tau$  is probably within experimental error, whereas for the intermediate wave-

<sup>1</sup> A. H. Compton and A. W. Simon, Phys. Rev. 25, 306 (1925).

lengths where the counting is more accurate the two ratios agree very well indeed.

Since we have seen that each  $P$  (photoelectron) track corresponds to the true absorption of a quantum of energy, this agreement means that on the average there is about one quantum of energy scattered for each  $R$  track that is produced. It follows that the  $R$  tracks are produced as an accompaniment of the *scattering* of X-rays.

This result is in itself contrary to the predictions of the classical electrodynamics, since on that basis *all* the energy spent on a free electron (except the insignificant effect of radiation pressure) reappears in the scattered rays. In these experiments on the contrary, 5 or 10 per cent as much energy appears in the motion of the  $R$  electrons as appears in the scattered X-rays.

That these  $R$  tracks, associated with the scattered X-rays, correspond to the recoil electrons predicted by the quantum theory of scattering, becomes clear when we compare their energy as shown by their range with that predicted by the theory. We have seen in the last chapter (eq. 8.41) that the range is approximately proportional to  $V^4$ , or to the square of the kinetic energy of the beta particle. Wilson finds<sup>1</sup> that  $R = V^2/44$  mm., where  $V$  represents the particle's initial energy expressed in kilovolts. Using this relation, we can calculate from equation (9.05) the range to be expected for the electrons recoiling at different angles  $\theta$ . For the maximum range, using X-rays of different wave-lengths, the following values were found<sup>2</sup> (column 2), as compared with those predicted (column 3). In the case of the hardest X-rays it was possible to compare the ranges of the tracks ejected at different angles, with the results shown in Table IX-3.

<sup>1</sup>This is the equivalent of the datum quoted on p. 256. C. T. R. Wilson, Proc. Roy. Soc. **104**, 1 (1923).

<sup>2</sup>A. H. Compton and A. W. Simon, loc. cit. In these experiments X-rays of approximate homogeneity were obtained by filtering. The calculations of Table IX-2 are based on the shortest wave-length present, while those of Table IX-3 are based on the average wave-length. Similar experiments, using the  $K_{\alpha}$  line of tungsten, have been performed by H. Ikeuti, Comptes Rendus **180**, 27 (1925), see Fig. 95.

TABLE IX-2  
MAXIMUM LENGTHS OF *R* TRACKS

Potential on X-ray Tube	Observed	Calculated Eq. 9-05
21 kv.	0 mm.	.06 mm.
34	0	.3
52	2 5	1 8
74	6	6
88	9	12
111	24	25

TABLE IX-3  
RANGE OF *R* TRACKS AT DIFFERENT ANGLES FOR 111 KV. X-RAYS

Angle of Emission	Average Range	
	Observed	Calculated
0°-30°	9 mm.	11 mm.
30°-60°	4	4
60°-90°	0 9	0 3

These results are typical of those obtained by a number of independent observers.<sup>1</sup> From their complete agreement with the predictions of the quantum theory, we are justified in identifying the *R* tracks with the recoil electrons. In view of the fact that electrons of this type were unknown at the time the quantum theory of scattering was presented, their existence and the close agreement with the predictions as to their number, direction and velocity, supplies strong evidence in favor of the fundamental hypotheses of the theory.

### 125. *Directed Quanta vs. Spreading Waves*

We thus find that the wave-length of the scattered rays is what it should be if a quantum of radiation bounced from an

<sup>1</sup> C. T. R. Wilson, Proc. Roy. Soc. 104, 1 (1923). W. Bothe, Zeits. f. Phys. 20, 237 (1923). A. H. Compton and J. C. Hubbard, Phys. Rev. 23, 439 (1924). H. Ikeuti, Comptes Rendus, 180, 27 (1925). D. Skobelczyn, Zeits. f. Phys. 28, 278 (1924).

electron, just as one billiard ball bounces from another. Not only this, but we actually observe the recoiling billiard ball, or electron, from which the quantum has bounced, and we find that it moves just as it should if a quantum had bumped into it. The obvious conclusion would be that X-rays, and so also light, consist of discrete units, proceeding in definite directions, each unit possessing the energy  $h\nu$  and the corresponding momentum  $h/\lambda$ .

### 126. *Waves vs. Conservation of Energy and Momentum*

If we wish to avoid this conclusion, and to retain the idea that energy proceeds in all directions from a radiating electron, we are presented with an alternative which is perhaps even more radical, namely, that when dealing with the interactions between radiation and electrons, the principles of the conservation of energy and momentum must be abandoned. It is indeed difficult to see how the idea of directed quanta can be reconciled with those experiments in which interference is secured between rays that have moved in different directions, as for example in the interferometer. The conviction of the truth of the spherical wave hypothesis produced by such interference experiments at one time led many physicists to choose rather the abandonment of the conservation principles.

The manner in which this alternative presents itself is very clearcut. If the energy radiated by an electron striking the target of an X-ray tube is distributed in all directions, only a very small fraction of it will fall upon any particular electron in the scattering material. But this minute fraction of the original radiated energy is sufficient to cause the ejection of a recoil electron with a considerable fraction of the energy of the initial cathode particle. Thus on the spherical wave hypothesis, when a recoil electron is ejected, it appears with many times as much energy as it receives from the incident radiation. In the corresponding case of the photoelectric effect, we have considered (Chapter VIII) the suggestion that energy is gradually accumulated and stored in the atom from which the photoelectron is

ejected. In the present case this view is even more difficult to defend than in the case of the photoelectric effect, for here the loosely bound electrons, and apparently even free electrons as well, would have to be able to store up energy as readily as those tightly bound within the atom.

The lack of conservation of momentum on the spherical wave view is even more clearly evident than is the sudden appearance of energy. For just as in the case of the energy received by the scattering electron, so also the impulse received by the electron from the incident radiation is on the wave theory insignificant. We find, however, that a recoil electron moves with a velocity comparable with that of light, suddenly acquiring a momentum in the forward direction which is incomparably greater than the impulse it receives from the incident ray on the usual wave theory. To retain the conservation of momentum, we might suppose that the remaining part of the atom recoils with a momentum equal and opposite to that of the scattering electron. But the experiments indicate that the momentum may be equally readily acquired whether the electron is loosely or tightly bound. It is thus clear that the momentum acquired depends only upon the scattering electron and the radiation, and has nothing to do with the remaining part of the atom. According to the spherical wave hypothesis, therefore, the electron does not receive an impulse as great as it is found to acquire.

If this work on the scattering of X-rays and the accompanying recoil electrons is correct, we must therefore choose between the familiar hypothesis that electromagnetic radiation consists of spreading waves, on the one hand, and the principles of the conservation of energy and momentum on the other. We cannot retain both.

The success of the applications of the conservation principles that have been made in this chapter to the problem of the scattering of radiation, inclines one to a choice of these principles even at the great cost of losing the spreading wave theory of radiation. Bohr, Kramers and Slater,<sup>1</sup> however, have shown

<sup>1</sup> N. Bohr, H. A. Kramers and J. C. Slater, *Phil. Mag.* **47**, 785 (1924); *Zeits. f.*

that both these scattering phenomena and the photoelectric effect may be reconciled with the view that radiation proceeds in spherical waves if the conservation of energy and momentum are interpreted as statistical principles.

### 127. *Scattering of Quanta by Individual Electrons*

The essential feature of this suggestion of Bohr, Kramers and Slater as applied to the present problem is the hypothesis that spherical electromagnetic waves are scattered by "virtual oscillators," one such oscillator corresponding to each electron in the scattering medium. These virtual oscillators scatter the radiation in spherical waves in a manner similar to that demanded by the classical theory; but to account for the change of wave-length, they are supposed to scatter as if moving with such a velocity that the Doppler effect will give the same effect as that predicted by the quantum theory. The radiation pressure, which on the classical theory would be uniformly distributed over all the scattering electrons, appears on this view as the momentum of a few recoil electrons. For no individual electron is the momentum conserved; but the momentum of all the recoil electrons is (over a long period of time) equal to the impulse imparted to the whole scattering block by the pressure of the radiation. Similarly, the difference between the energy spent on the virtual oscillators and that reappearing as scattered rays does not appear uniformly distributed among all the electrons, but rather as the kinetic energy of a small number of "recoil" electrons. Thus the energy, like the momentum, is conserved only statistically.

On this view, therefore, the radiation is continually being scattered, but only occasionally is a recoil electron emitted. This is in sharp contrast with the radiation quantum theory developed above, according to which a recoil electron appears every time a quantum is scattered. A crucial test between the two points of view is possible if one can detect individual recoil electrons and individual quanta of scattered X-rays. For on the quantum view a beta ray resulting from the scattered X-ray

should appear at the same instant as the recoil electron, whereas on the statistical view there should be no correlation between the time of production of the recoil electrons and the secondary beta rays due to the scattered radiation.

This experiment was devised and brilliantly performed by Bothe and Geiger.<sup>1</sup> X-rays were passed through hydrogen gas,

and the resulting recoil electrons and scattered rays were detected by means of two different point counters, arranged as shown in Fig. 113. Nothing was placed over the entrance to the chamber for counting the recoil electrons, but a window of thin platinum prevented recoil electrons from entering the chamber for counting the scattered quanta ("h $\nu$  counter"). Of course not every quantum entering the second counter will be noticed, for its detection depends upon the production of a  $\beta$ -ray. It was found that there were about 10 recoil electrons

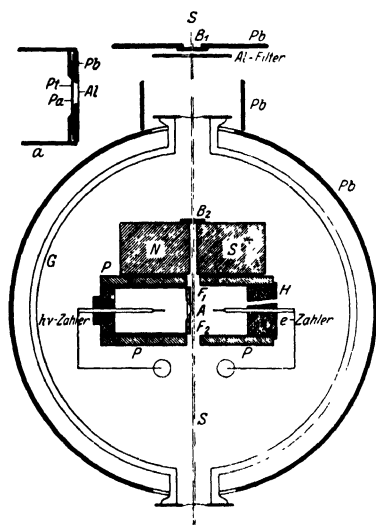

FIG. 113.

for every scattered quantum that recorded itself.

The impulses from the counting chambers were recorded on a moving photographic film, as shown in Fig. 114. Here the upper record is that of the recoil electron counter, and the lower one that of the quantum counter. The successive vertical lines represent intervals of .001 second. In this picture are shown *A*, an accurately simultaneous emission of electron and quantum, and *B*, a recoil electron for which no associated scattered quan-

<sup>1</sup> W. Bothe and H. Geiger, *Zeits. f. Phys.* **26**, 44 (1924); **32**, 639 (1925); *Naturwissenschaften*, **20**, 440 (1925).

A similar experiment, but with less definite results, has been performed also by R. D. Bennett, *Proc. Nat. Acad.* **11**, 601 (1925); cf. also A. H. Compton, *Proc. Nat. Acad.* **11**, 303 (1925).

tum was recorded. In observations over a total period of over five hours, 66 such coincidences were observed. Bothe and Geiger calculate that on the statistical theory of Bohr, Kramers and Slater the chance is only 1 in 400,000 that so many coincidences should have occurred.

We have found from the cloud expansion experiments that on the average there are about as many recoil electrons as there are scattered quanta. Combining this result with that of Bothe and Geiger's experiment, we see that there is a quantum of

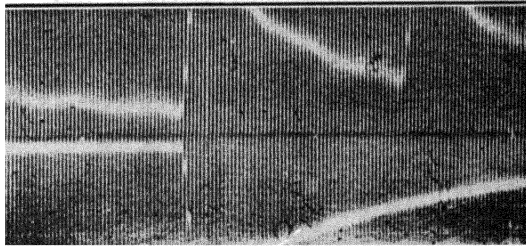

FIG. 114.

scattered X-rays associated with each recoil electron.<sup>1</sup> This is directly contrary to the suggestion made by Bohr, Kramers and Slater.

### 128. *Directed Quanta of Scattered X-rays*

Important information regarding the nature of the quantum associated with the recoil electron may be obtained by studying the relation between the direction of ejection of the recoil electron and the direction in which the associated quantum proceeds. According to equation (9.06) we should have the definite relation

$$\tan \frac{1}{2}\phi = - 1/(1 + \alpha) \tan \theta. \quad (9.08)$$

<sup>1</sup> In Table IX-1 we see that especially for the longer waves,  $N_R/N_P$  is somewhat less than  $\sigma/\tau$ , i.e., the number of recoil electrons is slightly less than the number of scattered quanta. This is probably due in part to the fact that for the unmodified scattered rays no recoil electrons should appear.

On the quantum theory, therefore, if the scattered ray produces a beta ray, the direction  $\phi$  in which the ray appears should be related to the angle  $\theta$  of the recoiling electron by the same expression. But according to any form of the spreading wave theory, including that of Bohr, Kramers and Slater, the scattered rays may produce effects in any direction whatever, and there should be no correlation between the directions in which the recoil electrons proceed and the directions in which the secondary beta rays are ejected by the scattered X-rays.

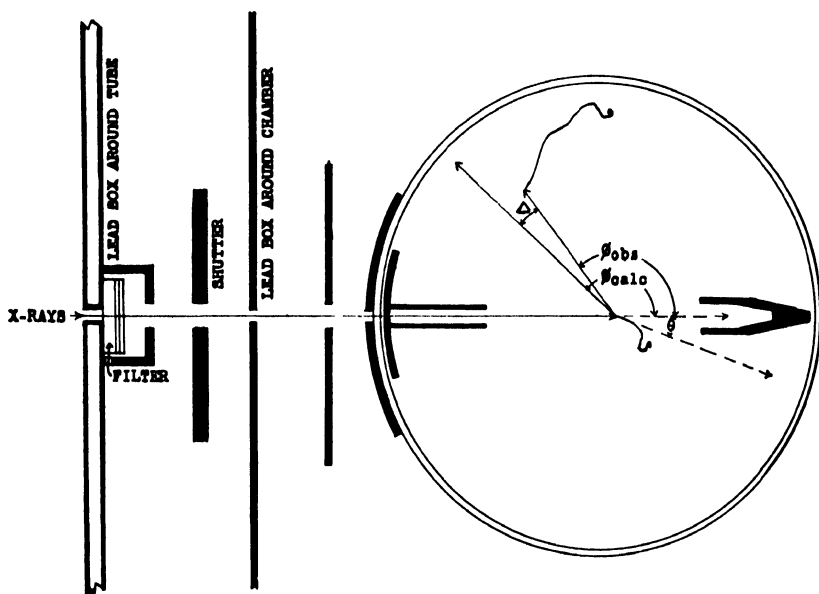

FIG. 115.

This test has been made by means of a Wilson cloud expansion apparatus,<sup>1</sup> in the manner shown diagrammatically in Fig. 115. Each recoil electron produces a visible track, and occasionally a secondary track is produced by the scattered X-ray, as in Fig. 116. When but one recoil electron appears on the same plate with the track due to the scattered rays, it is possible to tell at once whether the angles satisfy equation (9.08).

<sup>1</sup>This experiment was suggested by W. F. G. Swann, and performed by A. W. Simon and the author, *Proc. Nat. Acad. Sci.* 11, 303 (1925); *Phys. Rev.* 26, 289 (1925).

By the device of placing thin lead diaphragms in the expansion chamber, the probability that a scattered quantum would produce a beta ray inside the expansion chamber was made as great as 1 in 50. On the last 850 plates, 38 show both recoil tracks and secondary beta ray tracks. In 18 of these cases the observed angle  $\phi$  is within 20 degrees of the angle calculated from the measured value of  $\theta$ , while the other 20 tracks are distributed at random angles. This ratio 18 : 20 is about that to be expected for the ratio of the rays scattered by the part of

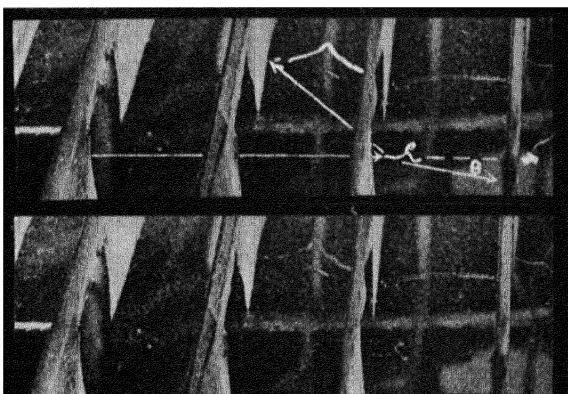

FIG. 116.

the air from which the recoil tracks could be measured to the stray rays from various sources.

Figure 117 shows graphically how the secondary beta rays are concentrated near the angle calculated from the direction of ejection of the recoil electrons.<sup>1</sup> The fact that so many of the

<sup>1</sup> When only one recoil electron and one secondary electron appeared on a photograph, the procedure was to record first the angle  $\theta$  at which the track of the recoil electron begins. Then the angle  $\phi$  between the incident ray and the line joining the origin of the recoil track and the origin of the secondary track was noted. The difference between this angle and the angle  $\phi$  calculated from  $\theta$  by equation (9.08) was called  $\Delta$ , and this value of  $\Delta$  was assigned a weight of unity. When a number  $n$  of recoil tracks appeared on the same plate with a secondary track, the value of  $\Delta$  was thus determined for each recoil track separately, and assigned a weight of  $1/n$ . Following this procedure there are values of  $\Delta$  which are distributed approximately at random

secondary tracks occur at angles for which  $\Delta$  is less than  $20^\circ$  means that equation 9.08 holds for each individual scattering event within experimental error. There is only about 1 chance in 250 that this agreement is accidental.

Since the only known effect of X-rays is the production of beta rays, and since the meaning of energy is the ability to produce an effect, this result means that there is scattered X-ray energy associated with each recoil electron sufficient to pro-

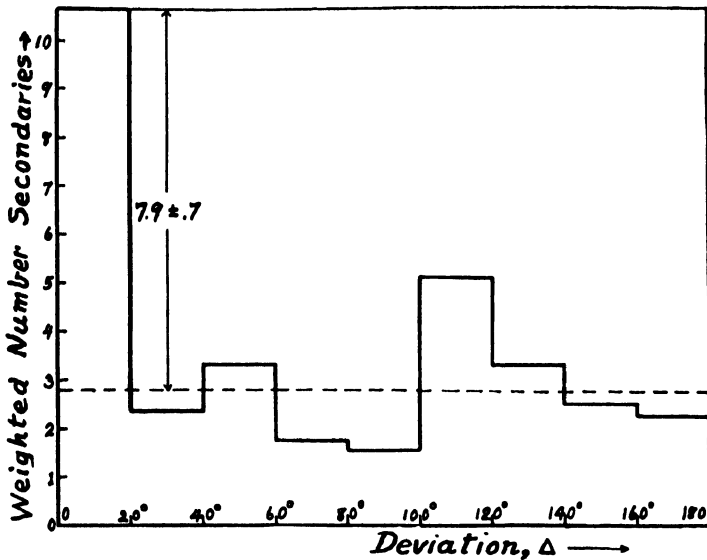

FIG. 117.

duce a beta ray and proceeding in a direction determined at the moment of ejection of the recoil electron. In other words, *the scattered X-rays proceed in directed quanta of radiant energy.*

Since other experiments show that these scattered X-rays can be diffracted by crystals, and are thus subject to the usual laws of interference, there is no reason to suppose that other

between 0 and  $180^\circ$  due to the  $n - 1$  recoil electrons which are not associated with the secondary track. This is in addition to the random values of  $\Delta$  resulting from the presence of stray X-rays. Plates on which more than three recoil tracks appeared were discarded.

forms of radiant energy have an essentially different structure. It thus becomes highly probable that all electro-magnetic radiation is constituted of discrete quanta proceeding in definite directions.

This result, like that of Bothe and Geiger, is irreconcilable with Bohr, Kramers and Slater's hypothesis of the statistical production of recoil and photoelectrons. On the other hand, we see that equations (9.04), (9.05) and (9.06) are completely verified.

Unless the experiments we have been considering have been affected by improbably large experimental errors, I can see no escape from the conclusion that the fundamental assumptions on which the quantum theory of scattering is based are valid. To be specific, (1) that the incident X-ray beam is divisible into discrete units possessing energy  $h\nu$  and momentum  $h\nu/c$ , and that these units, or quanta, may be scattered one at a time in definite directions by individual electrons, and (2) that when a quantum is scattered by an electron, energy and momentum are conserved in the process.

How these conclusions are to be reconciled with the experiments which have led to the wave theory of radiation is another and a difficult question. The very considerable success of the wave theory as applied in Chapters III, IV, and V to problems of the intensity of X-ray scattering gives confidence that such a reconciliation must be possible. The main point of this chapter has been, however, to show how existing evidence demands that we adjust our ideas to include the existence of directed quanta of electromagnetic radiation.

## II. QUANTA SCATTERED BY BOUND ELECTRONS

### 129. *Ejection of Bound Electrons by Scattered Quanta*

If we retain the conception used in the theory of scattering by free electrons, that each X-ray quantum is scattered by an individual electron, two cases are to be considered, that in which the electron is not ejected from its atom, and that in

which the scattering electron receives an impulse sufficient to eject it from the atom.

In the first case, evidence from X-ray spectra indicates that there is no resting place for the electron within the atom after it has scattered the quantum unless it returns to its original energy level. The final energy of the atomic system is thus the same after the quantum is scattered as it was before (the kinetic energy imparted by the deflected quantum to a body as massive as an atom being negligible), implying that the frequency of the scattered ray is unaltered. Scattering by this process would thus give rise to an unmodified line, as has been suggested above (p. 14). In the second case, however, part of the energy of the incident quantum is spent in removing the scattering electron from the atom, part is used in giving to the electron and the ionized atom their final motions, and the remainder appears as the scattered ray. It is clear that all the quanta scattered in this manner will be modified. We wish to determine what fraction of the rays will be modified, and to what extent the wave-length will be changed.

### 130. *Limits Imposed by Conservation of Energy*

Some information on these points is available from simple considerations of the conservation of energy.<sup>1</sup> The energy equation is,

$$h\nu = h\nu' + h\nu_s + mc^2\left(\frac{1}{\sqrt{1-\beta^2}} - 1\right) + \frac{1}{2}MV^2, \quad (9.09)$$

where, as compared with equation (9.01),  $h\nu_s$  is the energy required to remove the scattering electron from the atom, and  $\frac{1}{2}MV^2$  is the kinetic energy imparted to the remainder of the atom. The frequency  $\nu'$  will be a maximum when the kinetic energy of the electron is zero, in which case, since  $\frac{1}{2}MV^2$  is negligible compared with  $h\nu$ ,

$$h\nu'_{\max} = h\nu - h\nu_s,$$

or

$$\delta\lambda_{\min} = \lambda'_{\min} - \lambda = \lambda^2/(\lambda_s - \lambda). \quad (9.10)$$

<sup>1</sup> Cf. A. H. Compton, Phys. Rev. 24, 168 (1924).

There is no finite lower limit to the frequency, since equation (9.09) may be satisfied with  $\nu' = 0$ . Thus the wave-length of the scattered ray may have any value for which <sup>1</sup>

$$\lambda' > \lambda + \lambda^2/(\lambda_s - \lambda). \quad (9.11)$$

It is possible for the electron to be thrown from the atom, and hence for a modified ray to be produced, only if  $\nu > \nu_s$ . On the other hand, it is consistent with this equation and the corresponding momentum equations for the whole atom to take the impulse due to the quantum, in which case the energy lost by the quantum is negligible. Thus a modified ray is never definitely predicted when the momentum of the atom as well as that of the scattering electron is considered. Though these limiting conditions are very broad, they are nevertheless sufficient to rule out any modified ray in the case of the experiments by Ross in which ordinary light was scattered by paraffin and reflected from mirrors (see p. 272).

### 131. *Assumption of Instantaneous Action on Electron*

In order to obtain a more definite solution of the problem, we must make some assumption regarding the manner in which the X-ray quantum acts on the electron. Probably the simplest dynamical picture <sup>2</sup> is given by the assumption that the quantum's action is instantaneous and is applied to the electron. If the impulse is sufficient to eject the electron from the atom, we then calculate the wave-length change from the difference in kinetic energy of the scattering electron just before and just after impact; whereas if the impulse is insufficient to eject

<sup>1</sup> This is precisely the wave-length range predicted by Clark and Duane's hypothesis of "tertiary radiation" (see Note 1, p. 11). The present theory, however, does not demand a continuous spectral energy distribution over this range, as did theirs.

<sup>2</sup> Other typical assumptions that might be made are (a) when the electron is ejected the ionized atom remains at rest, and (b) that the atom absorbs from the incident quantum sufficient energy to free the electron, which then scatters the remainder of the quantum in a definite direction. These hypotheses have not been found to give as satisfactory agreement with experiment as the simpler hypothesis discussed here (cf. A. H. Compton, Phys. Rev. 24, 168 (1924)).

the electron we must suppose an unmodified ray to be produced. In the limiting case, in which the electron is ejected, but with zero final kinetic energy, it will be seen that equation (9.10) must give the wave-length of the modified ray. On this assumption, therefore, the wave-length of the modified ray is calculated from energy and momentum equations like those (9.01)–(9.03) used for free electrons, except that the initial momentum of the scattering electron is not zero but is the momentum of its orbital motion, noting, however, that only the wave-lengths included in equation (9.11) can occur. It is on this basis that Jauncey has developed his theory<sup>1</sup> of the broadening of the modified line and of the relative prominence of the modified and unmodified lines.

Let us write  $p$  as the momentum of the electron in its orbit immediately before it scatters the quantum, and  $l, m, n$  its direction cosines. Just after the impact but before the electron has moved appreciably from its orbit, the corresponding quantities are  $p', l', m', n'$ . We shall write also  $b \equiv p/mc$  and  $b' \equiv p'/mc$ . The kinetic energies before and after impact are then given by the equation (cf. eq. 4, Appendix VI).

$$\alpha + (\sqrt{1 + b^2} - 1) = \alpha' + (\sqrt{1 + b'^2} - 1), \quad (9.12)$$

where  $\alpha \equiv h\nu/mc^2$  and  $\alpha' \equiv h\nu'/mc^2$  as before. We have now 3 momentum equations (cf. eqs. 5 and 6, Appendix XI),

$$X \quad \alpha + bl = \alpha'l_1 + b'l' \quad (9.13)$$

$$Y \quad 0 + bm = \alpha'm_1 + b'm' \quad (9.14)$$

$$Z \quad 0 + bn = 0 + b'n', \quad (9.15)$$

where  $l_1, m_1, 0$  are the direction cosines of the scattered ray. Also, of course,

$$l'^2 + m'^2 + n'^2 = 1. \quad (9.16)$$

<sup>1</sup>G. E. M. Jauncey, *Phys. Rev.* **25**, 314 and 723 (1925). In an earlier paper he developed a less satisfactory theory on slightly different assumptions (*Phil. Mag.* **49**, 427, 1925).

132. *Theory for Circular Orbits*

In order from these 5 equations to determine  $\alpha'$ ,  $b'$ ,  $l'$ ,  $m'$  and  $n'$ , we must know the initial value of the electron's momentum, or  $b$ ,  $l$ ,  $m$ ,  $n$ . Jauncey takes the motion to be that of the electron in its Bohr orbit in the atom. For circular orbits, neglecting screening effects, this is given by equation (8.31) as

$$p = mc\sqrt{2\alpha_s - \alpha_s'^2}/(1 - \alpha_s),$$

where  $\alpha_s = h\nu_s/mc^2$  and  $\nu_s$  is the critical ionization frequency for the electron in its orbit. Thus

$$b = \sqrt{2\alpha_s - \alpha_s'^2}/(1 - \alpha_s). \quad (9.17)$$

Using this value, we find on solving the above equations,

$$\frac{\lambda'}{\lambda} = \frac{\alpha}{\alpha'} = \frac{u - (lv l_1 + mm_1)}{1 - vl}, \quad (9.18)$$

where

$$\left. \begin{aligned} u &= 1 + \alpha(1 - \alpha_s)(1 - l_1), \\ v &= \sqrt{2\alpha - \alpha_s'^2}. \end{aligned} \right\} \quad (9.19)$$

The maximum and minimum values of this ratio can be shown to be,

$$\frac{\lambda'}{\lambda} = \frac{u - v^2 l_1 \pm v\sqrt{1 + u^2 - 2ul_1 - v^2 m_1^2}}{1 - v^2}. \quad (9.20)$$

This means a change of wave-length of magnitude,

$$\begin{aligned} \delta\lambda \equiv \lambda' - \lambda &= \frac{\alpha\lambda(1 - l_1)}{1 - \alpha_s} - \lambda(1 - l_1)[1 - 1/(1 - \alpha_s)^2] \\ &\quad \pm \frac{\lambda v}{1 - v^2} \sqrt{1 + u^2 - 2ul_1 - v^2 m_1^2}. \end{aligned} \quad (9.21)$$

When  $\alpha$  is small and  $\alpha_s$  is very small this becomes approximately

$$\begin{aligned} \delta\lambda &= \alpha\lambda(1 - l_1) \pm 2\lambda\sqrt{\alpha_s(1 - l_1)} \\ &= \gamma \text{ vers } \phi \pm 2\lambda\sqrt{\alpha_s \text{ vers } \phi}. \end{aligned} \quad (9.22)$$

If we assume that the probability that an electron will scatter the quantum is independent of the electron's velocity, the intensity of the scattered rays should be nearly uniform over this range of wave-lengths.

In the case of the molybdenum  $K\alpha$  rays scattered at 90 degrees by electrons in the  $K$  orbits of carbon,  $\lambda = .710\text{A}$ ,  $\lambda_s = 49\text{A}$ ,  $\alpha_s = .00050$ , and  $\text{vers } \phi = 1$ , whence  $\delta\lambda = .0243 \pm .0317\text{A}$ , according to equation (9.22). This band due to the modified rays is represented in Fig. 118 by the rectangle extending from  $A$  to  $B$ . The line  $OP$  represents the wave-length of the primary ray, and  $M$  represents the modified ray according

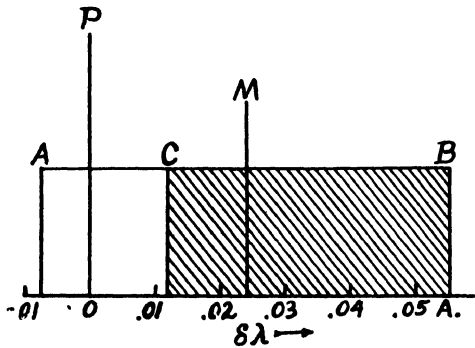

FIG. 118.

to equation (9.04). The breadth  $AB$  of this modified band may be thought of as due to the Doppler effect arising from the orbital motions of the scattering electrons.

According to equation (9.10), however, only those wave-lengths can occur in the modified line for which  $\delta\lambda > .012\text{A}$ ; that is in Fig. 118, only the shaded portion of the rectangle between  $C$  and  $B$  can be present. Those collisions between electrons and quanta which would have resulted in  $\delta\lambda$  between  $A$  and  $C$  cannot eject the recoiling electron, and so must give rise to unmodified rays. On this theory therefore if  $OA > OC$  no unmodified ray will be present, whereas if  $OC > OB$  all the rays scattered by electrons in such orbits should be unmodified. It is a significant fact that according to this criterion an un-

modified line due to the  $K$  electrons in carbon should occur in each curve of Fig. 108; but in the case of lithium, as shown in Fig. 110, using  $\lambda_s = 235\text{\AA}$  and  $\phi = 110^\circ$ ,  $OC = .002\text{\AA}$  while  $OA = +.017\text{\AA}$ , so that no unmodified ray should occur. The agreement of the experiments with these predictions gives some confidence in Jauncey's theory.

Regarding the relative intensities of the modified and the unmodified lines, Jauncey's theory is not so specific. The simplest assumption would be to suppose that the ratio of the number of unmodified to modified quanta is equal to the ratio of the unshaded to the shaded portion of the rectangle  $AB$ . It is very likely, however, that there is a greater *a priori* probability for an unmodified encounter than for one resulting in a modified ray. We have seen in Chapter III that there is good evidence that the electrons within an atom cooperate with each other through interference. It seems impossible that such cooperation should occur for the modified ray, whose interpretation rests upon the assumption that each quantum is scattered by a single electron. If this is correct, we must ascribe any existing cooperation to the unmodified ray. That is, to account for the fact that for great wave-lengths scattered at small angles the intensity is greater than calculated for independent electrons, we should have to assume that an encounter resulting in an unmodified ray, in which the whole atom may be effective, is intrinsically more probable than one that gives rise to a modified ray. Thus the ratio of the energy in the unmodified ray to that in the modified ray should be greater (by a factor which is undetermined) than the ratio of  $AC$  to  $CB$  of Fig. 118. This conclusion, though only qualitative, is in accord with the experiments.

### 133. *Case of Elliptic Orbits*

In the experimental spectra of the scattered rays shown in Figs. 108–112, though the modified line is always diffuse, it is not as broad as represented by the shaded area in Fig. 118. Jauncey ascribes this to the fact that most of the electrons

which scatter the X-rays are, in accord with current atomic theory, revolving in elliptic orbits, and are most of the time moving comparatively slowly in the outer parts of their orbits. The method of solving the problem<sup>1</sup> is the same as for the circular orbits, except that the result has to be averaged over the different possible velocities of the electron in its orbit.

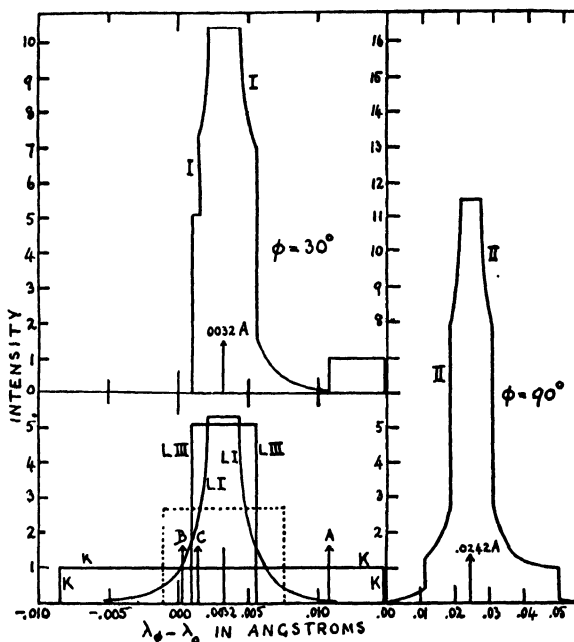

FIG. 119.

The results of such a calculation in the case of carbon are shown in Fig. 119, taken from Jauncey's paper. It is assumed that in the carbon atom there are:

2 electrons in circular  $K$  ( $I_1$ ) orbits for which  $\lambda_0 = 47A$ ,

2 electrons in circular  $L_{III}$  ( $2_2$ ) orbits for which  $\lambda_0 = 1200A$ ,

and

2 electrons in elliptical  $L_I$  ( $2_1$ ) orbits for which  $\lambda_0 = 350A$ .

<sup>1</sup> G. E. M. Jauncey, Phys. Rev. **25**, 723 (1926).

The lower left corner of the figure shows separately the contributions to be expected at  $\phi = 30^\circ$  from each electron group, the lines *A*, *B* and *C* representing the minimum wave-length change  $\lambda^2/(\lambda_s - \lambda)$  for the *K*, *L*<sub>III</sub> and *L*<sub>I</sub> electrons respectively. In the upper left figure the three curves are combined to show the calculated form of the modified band for  $\phi = 30^\circ$ . At the right is a similar curve for  $\phi = 90^\circ$ .

#### 134. *Partial Experimental Confirmation*

The general form of the calculated curves is rather similar to the observed ionization curves shown in Figs. 108 and 110. They agree also with Sharp's experiments (p. 12) in placing the peak of the modified line exactly at  $\delta\lambda = \gamma$  vers  $\phi$ . The observation of the discontinuous character of curves I and II is beyond our present experimental technique. On the whole, however, it seems that the width of the lines as thus calculated is greater than indicated by the experiments. This is shown in a striking manner by Ross' photograph reproduced in Fig. 111, in which the lines are sufficiently sharp to separate the modified  $K\alpha_1$  from the modified  $K\alpha_2$  lines, though these are separated by only .0043A. Fig. 111 represents the rays scattered from aluminium, but similar photographs by Ross using rays scattered by carbon also show these lines resolved.<sup>1</sup> In curve II of Fig. 119, the horizontal plateau at the top of the curve has a width of about .006A, which would make the resolution of these lines impossible. Unless this apparent resolution is due to some idiosyncrasy of the photographic plate, we must conclude that Jauncey's theory in its present form predicts too great a width for the modified lines.

If we grant that in the production of the modified rays single quanta are scattered by single electrons and that energy and momentum are conserved in the process, this means either that the time of interaction between the quantum and the electron is not negligible, or that the electrons are not moving

<sup>1</sup> These photographs using a carbon radiator are reproduced in a paper by the author in Franklin Inst. J., July, 1924, p. 64.

as fast inside the atom as the Bohr-Sommerfeld theory supposes. More experimental information is however needed regarding the shape of the modified line before we can give this part of the theory a really adequate test.

The most definite test of the present theory is afforded by measurements of the angle at which the unmodified line disappears for different wave-lengths and different scattering materials. This limit is determined by the most firmly bound, or  $K$ , electrons in the scattering material, and is given from equations (9.10) and (9.22) by,

$$\delta\lambda_{\min} = \frac{\lambda^2}{\lambda_s - \lambda} < \gamma \text{ vers } \phi - 2\lambda\sqrt{\alpha \text{ vers } \phi}. \quad (9.22a)$$

DeFoe<sup>1</sup> has recently measured the ratio of the modified to the unmodified scattering by comparing the absorption coefficients of the primary and scattered rays. His results are throughout in rather satisfactory accord with Jauncey's theory. On the other hand, Woo's recent spectra, such as those in Fig. 110, show unmodified lines in the rays scattered by beryllium and boron. This is contrary to the predictions of equation (9.22a).

A third test of the theory lies in a calculation of the ratio of the number of recoil to photoelectrons observed in the cloud expansion photographs. Jauncey and DeFoe<sup>2</sup> have attempted to account on this basis for the differences between the values of  $N_R/N_p$  and observed in the experiments of Simon and the author; but, as we have seen, systematic errors in the experimental values of  $N_R/N_p$  are so prominent for the wave-lengths at which these differences are observed that such a test is of little significance. As I am writing this, however, a paper by Nuttall and Williams<sup>3</sup> appears in which Jauncey's theory is applied to a set of their own experimental values of  $N_R/N_p$ , obtained with X-rays reflected from a crystal. Their data, shown in Table IX-4, seem to be free from the systematic errors which affect the data of Simon and the author for these wave-

<sup>1</sup> O. K. DeFoe, Phys. Rev. 1926.

<sup>2</sup> G. E. M. Jauncey and O. K. DeFoe, Phys. Rev. 26, 433 (1925).

<sup>3</sup> J. M. Nuttall and E. J. Williams, Manchester Memoirs, 70, 1 (1926).

lengths. It will be seen that their observed  $N_R/N_p$  values agree more exactly with the values in the last column calculated on the basis of Jauncey's theory than they do with the values of  $\sigma/\tau$ . Nuttall and Williams consider the agreement between the last two columns to be within the combined probable error of the experiments and the calculations.

TABLE IX-4  
NUMBER OF RECOIL AND PHOTOELECTRON TRACKS

Gas	$\lambda$ in $\text{Å}$	R Tracks, $N_R$	P Tracks, $N_P$	$\frac{\sigma}{\tau}$	$\frac{N_R}{N_P}$ Obs.	$\frac{N_R}{N_P}$ Calc.
Air.....	1 54	.....	.....	.02	.00	
Oxygen.....	.614	119	613	.28	.194	.227
Nitrogen.....	.614	116	406	.42	.286	.340
Air.....	.57	137	418	.41	.33	.34
Air.....	.35	153	97	1 75	1 58	1 61

It thus seems that when we take into consideration the effect of the electron's motions in their orbits, and the energy required to remove them from their atoms, we are able to account for the main departures from the simple theory. That is we account for the existence of the modified line and the fact that it increases in relative prominence with increasing wavelength and atomic number, we interpret the broadening of the modified line, and we explain the fact that for the softer rays the number of recoil electrons is somewhat less than the number of scattered quanta.

The evidence seems to show, however, that in its details the theory as developed by Jauncey does not accurately describe the width of the modified line, nor predict correctly the occurrence of the unmodified line. This partial failure may be due to an appreciable time of interaction between quanta and electrons, or it may be that the electrons do not move with as great velocity as the current form of atomic theory would lead us to expect.

## III. INTENSITY OF THE SCATTERED X-RAYS

135. *Unsatisfactory Status of Existing Intensity Formulas*

We are not in a position to develop a quantum theory of the intensity of the scattering of X-rays on the basis of principles sufficiently well established to give us confidence in the correctness of the solution at which we arrive. The problem is not however hopeless, as is indicated by the fact that the very first of the many quantum theories that have been presented gives results which, though perhaps somewhat arbitrary, are correct within the precision of our present experiments.

136. *Limiting Formulas Suggested by Correspondence Principle*

All forms of the quantum theory of X-ray scattering are based on the assumption that for long wave-lengths, where the motion imparted to the scattering electron is small, the intensity of the scattered rays approaches that assigned by Thomson's classical theory. That is, if  $\phi$  is the angle of scattering and  $I$  is in intensity of the primary rays, an electron scatters rays of intensity (eq. 3.04),

$$I_e = I \frac{e^4}{2m^2 r^2 c^4} (1 - \cos^2 \phi). \quad (9.23)$$

Similarly, the scattering coefficient per electron is (eq. 3.06),

$$\sigma_0 = \frac{8\pi}{3} \frac{e^4}{m^2 c^4}. \quad (9.24)$$

For the shorter wave-lengths, the scattering electron recoils away from both the primary ray and the scattered ray, and analogy with the classical Doppler effect would demand that the intensity be less than given by equation (9.23). It should, however, approach equality with this expression for  $\phi = 0$ , since at this angle the velocity of recoil is zero.

Following the ideas underlying Bohr's correspondence principle, we should expect to find an intensity which lies be-

tween the value assigned by equation (9.23) and that which one would calculate according to the classical theory for an electron moving with the final recoil velocity at the angle  $\theta$  given by equation (9.06). By use of Pauli's elegant method of "normal coordinates," Breit has shown <sup>1</sup> that this minimum limit for the intensity at the angle  $\phi$  is

$$I_{\phi \text{ min}} = I_e \cdot (\nu'/\nu)^4, \quad (9.25)$$

where  $\nu'$  and  $\nu$  are the scattered and incident frequencies respectively, and  $I_e$  is given by (9.23). From equation (9.04) this becomes,

$$I_{\phi \text{ min}} = I_e / (1 + \alpha \text{ vers } \phi)^4. \quad (9.26)$$

The true value of  $I_\phi$  should thus lie between that given by (9.23) and that assigned by equation (9.26). As we shall see, the experimental values for X-rays of short wave-length do seem to lie between these limits.

The assignment of such limits is as far as we have been able to carry the theoretical calculation with any considerable degree of assurance. We do not know what rule should guide us in taking the average between equations (9.23) and (9.26). We are, however, able definitely to rule out some formulas that have been suggested.

### 137. Proposed Intensity Formulas

1. *Debye*. In Debye's original presentation of the quantum theory of scattering <sup>2</sup> he suggested that the number of quanta scattered in any direction  $\phi$  might be that assigned by the classical theory, namely  $I_e/h\nu$ , but in view of the reduced frequency the energy in each quantum would be reduced in the ratio  $h\nu'/h\nu$ . This leads at once to the expression

$$I_\phi = I_e \cdot \frac{\nu'}{\nu} = I_0 \cdot \frac{I}{2} \frac{1 + \cos^2 \phi}{1 + \alpha \text{ vers } \phi}. \quad (\text{Debye}), \quad (9.27)$$

<sup>1</sup> G. Breit, Phys. Rev. 27, 242 (1926).

<sup>2</sup> P. Debye, Phys. Zeits. 24, 161 (1923).

where  $I_0 \equiv Ie^4/m^2r^2c^4$  is the intensity of the rays scattered at  $\phi = 0$  according to both limiting equations (9.23) and (9.26). Equation (9.27) obviously lies between (9.23) and (9.26), and is thus a kind of average between the two.

Though the intensity of the scattered rays is thus reduced, since the number of scattered quanta remains unchanged the energy removed from the primary beam is also unaltered. Thus *the scattering absorption* coefficient, or fraction of the primary energy removed by the scattering process, is the same as on the classical theory. That is,

$$\sigma = \sigma_0. \quad (\text{Debye}) \quad (9.28)$$

Whatever uncertainties may be present in the experiments, one thing which is definitely established is that the total absorption of hard X-rays and  $\gamma$ -rays is less than  $\sigma_0$  (see Fig. 31). Since  $\sigma$  cannot be greater than the total absorption, it follows that it is experimentally less than  $\sigma_0$ . This definite conflict with experiment excludes Debye's form of the theory of the intensity of scattered X-rays.

2. *A. H. Compton—Woo.* It is an interesting fact that the wave-length  $\lambda'$  represented by equations (9.04) varies with the angle just as one would expect from a Doppler effect due to electron moving in the direction of the primary beam. We have from equation (9.04),

$$\nu'/\nu = 1/(1 + \alpha \text{ vers } \phi); \quad (9.29)$$

but according to the Doppler principle, if the scattering electrons are moving with a velocity  $\beta c$  in the direction of the primary beam, the frequency of the scattered ray is given by

$$\nu'/\nu = 1/\left(1 + \frac{\beta}{1 - \beta} \text{ vers } \phi\right). \quad (9.30)$$

If  $\beta$  has the value

$$\bar{\beta} = \alpha/(1 + \alpha), \quad (9.31)$$

equations (9.29) and (9.30) become identical. Thus the change in frequency predicted by the quantum theory can be calcu-

lated also from the classical theory if we suppose that the scattering electrons are moving forward with the velocity  $\bar{\beta}c$ .<sup>1</sup>

It is natural to suppose, since when applied to such moving electrons the classical theory gives the correct wave-length, that it will give also the correct intensity. By a mixed classical and quantum treatment of the problem, the author showed<sup>2</sup> that if the scattering electron is moving in the direction of the primary beam with a velocity  $\bar{\beta}c$ , the ratio of the intensity at an angle  $\phi$  to that scattered in the forward direction is

$$\frac{I_{\phi}}{I_{\phi=0}} = \frac{1}{2} \frac{1 + \cos^2 \phi + 2\alpha(1 + \alpha) \text{vers}^2 \phi}{(1 + \alpha \text{vers} \phi)^5} \left\{ \begin{array}{l} \text{Compton} \\ \text{Woo} \end{array} \right\} \quad (9.32)$$

The solution of the problem was completed by Woo,<sup>3</sup> who applied Lorentz transformations to the electromagnetic field due to a scattering electron at rest. He found that the intensity scattered in the forward direction by an electron with the velocity  $\alpha c/(1 + \alpha)$  is

$$I_{\phi=0} = I \frac{e^4(1 + 2\alpha)}{m^2 r^2 c^4} = I_0(1 + 2\alpha). \quad (\text{Woo}) \quad (9.33)$$

<sup>1</sup> It so happens that this velocity  $\bar{\beta}c$  is just that which an electron would acquire by the absorption of the energy quantum  $h\nu$  or by scattering such a quantum (A. H. Compton and J. C. Hubbard, *Phys. Rev.* **23**, 442, 1924). This has led several writers to derive a semi-classical theory of the wave-length change, based on the idea that the electron scatters its energy in all directions after it has acquired the velocity  $\bar{\beta}c$ . Cf. C. R. Bauer, *C. R.* **177**, 1211 (1923); C. T. R. Wilson, *Proc. Roy. Soc.* **104**, 1 (1923); K. Forsterling, *Phys. Zeits.* **25**, 313 (1924); O. Halpern, *Zeits. f. Phys.* **30**, 153 (1924).

On this view, the recoil electrons should all move forward with the velocity  $\bar{\beta}c$ . The experiments of Simon and the author, described on p. 18, show, however, maximum velocities twice as great as this, and velocities varying in magnitude and direction in complete accord with the directed quantum theory. Thus  $\beta c$  represents merely an "effective" velocity, not a real velocity, of the recoil electrons.

<sup>2</sup> A. H. Compton, *Phys. Rev.* **21**, 493 (1923).

<sup>3</sup> Y. H. Woo, *Phys. Rev.* **25**, 444 (1925). Partial solutions of this problem have been offered also by, K. Forsterling, *Phys. Zeits.* **25**, 313 (1924); O. Halpern, *Zeits. f. Phys.* **30**, 153 (1924). A simple and complete solution is given by G. Wentzel, *Phys. Zeits.* **26**, 436 (1925), who also presents an excellent review of the whole subject.

It follows that

$$I_{\phi} = I_0 \frac{1}{2} \frac{1 + 2\alpha}{(1 + \alpha \text{vers } \phi)^5} \{1 + \cos^2 \phi + 2\alpha(1 + \alpha) \text{vers}^2 \phi\}. \quad (\text{Woo}) \quad (9.34)$$

We see at once that equation (9.33) does not agree with (9.23) and (9.26), according to which  $I_{\phi=0}$  should equal  $I_0$ . Thus equation (9.34) cannot be correct unless even the broad form of the correspondence principle used in deriving the two limiting equations is inapplicable.

The most significant experimental test is again obtained by evaluating the scattering absorption coefficient. The total number of scattered quanta is clearly

$$n_s = \int_0^{\pi} \frac{1}{h\nu'} I_{\phi} \cdot 2\pi r^2 \sin \phi d\phi.$$

But each of these quanta represents the removal of energy  $h\nu$  from the primary beam. The scattering absorption coefficient, or fraction of the incident energy which is scattered per electron, is therefore

$$\sigma = \frac{n_s h\nu}{I} = \int_0^{\pi} \frac{I_{\phi}}{I} \cdot \frac{\nu}{\nu'} 2\pi r^2 \sin \phi d\phi. \quad (9.35)$$

Substituting  $I_{\phi}$  from equation (9.34) and  $\nu/\nu'$  from (9.29) and integrating, we obtain

$$\sigma = \frac{8\pi}{3} \frac{e^4}{m^2 c^4} = \sigma_0. \quad (\text{Woo}) \quad (9.36)$$

We have already noticed the inconsistency of this result with the experimental fact that  $\sigma$  is for short wave-lengths very considerably less than  $\sigma_0$ . On this basis Woo concluded that the present method of calculating the intensity is unreliable.

3. *A. H. Compton.*<sup>1</sup> We have seen that equations (9.23) and (9.26) determine  $I_{\phi=0}$  as equal to  $I_0$ . If we assume also

<sup>1</sup> A. H. Compton, Phys. Rev. 21, 491 (1923).

that the relative intensity at different angles is given by equation (9.32), then

$$I_\phi = I_0 \frac{1 + \cos^2 \phi + 2\alpha(1 + \alpha) \text{vers}^2 \phi}{2(1 + \alpha \text{vers} \phi)^5}. \quad (\text{Compton}) \quad (9.37)$$

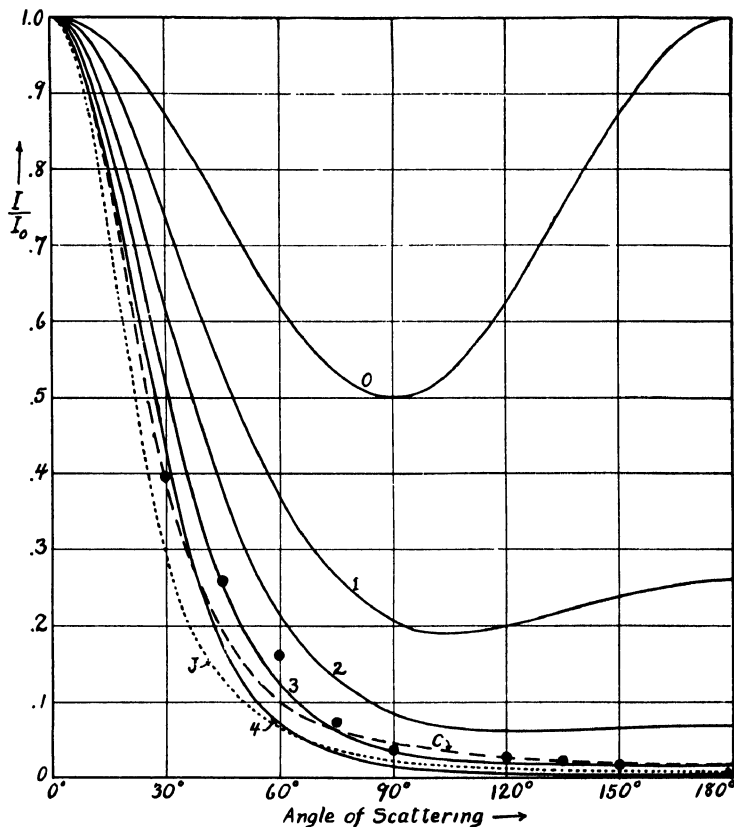

FIG. 120.

In Fig. 120 this value of  $I_\phi$  is plotted as the broken line  $C$  for  $\alpha = 1.42$ , while equations (9.23) and (9.26) are represented by curves 0 and 4 respectively. It will be seen that although the broken line lies between these two curves for the greater part of its length, at small angles  $\phi$  it falls below curve 4. At these angles, therefore, equation (9.37) predicts values of the in-

tensity less than the minimum limit (eq. 9.26) based on the correspondence principle. It therefore seems difficult to reconcile the present formula for the intensity with the correspondence principle.<sup>1</sup> On the other hand this formula is in surprisingly good accord with the experiments.

When we calculate the scattering absorption coefficient according to equation (9.35), using the value of  $I_\phi$  given by equation (9.37), we obtain

$$\sigma = \sigma_0 / (1 + 2\alpha). \quad (\text{Compton}) \quad (9.38)$$

This formula indicates a reduction in the scattering absorption with increasing frequency, which is in good accord with the experiments.

4. *Jauncey*. An interestingly novel solution of the problem has been presented by Jauncey.<sup>2</sup> He conceives of the scattering of X-ray quanta by electrons as analogous to the bounding of peas from a football. If  $a$  is the effective radius of an electron, the probability that it will be struck by a quantum of negligible size which traverses unit area surrounding the electron, is equal to the cross sectional area  $\pi a^2$  of the electron. But this is by definition the scattering coefficient per electron, i.e.,

$$\pi a^2 = \frac{8\pi}{3} \frac{e^4}{m^2 c^4}.$$

Thus

$$a = \sqrt{\frac{8}{3}} \frac{e^2}{mc^2},$$

which is of the same order of magnitude as the radius  $a = \frac{2}{3} e^2 / mc^2$  of the usual electron theory, calculated on the assump-

<sup>1</sup> It would be possible for the average value of the intensity to be less than the intensity from an electron with the final velocity if some of the intermediate velocities were greater than the final velocity. For example, an electron might be set in motion by receiving the initial quantum, and then be reduced to its final velocity by scattering the quantum in the forward direction. While such a process seems improbable, it makes one hesitate to rule equation (9.37) definitely out on the basis of the correspondence principle.

<sup>2</sup> G. E. M. Jauncey, *Phys. Rev.* **22**, 233 (1923).

tion that the electron is a spherical shell of electricity. Such an agreement as to order of magnitude is all that one could anticipate. If the electron, then, has the effective size assigned by this expression, the scattering coefficient will have the value  $\sigma_0$  assigned by the classical theory.

In order to calculate the distribution of the scattered rays, Jauncey assumes such a shape for the electron that if the quantum is of negligible mass (i.e., of great wave-length) the deflected quanta will be distributed according to the relation  $(1 + \cos^2 \phi)$ . For frequencies so high that the mass of the quantum is comparable with that of the electron, the electron will recoil from the scattered quantum, resulting in a greater probability for the quantum to move in a forward direction. Neglecting any change in the effective shape of the electron resulting from the high velocity acquired from impact with such a quantum, he is able to calculate in this way the relative intensity of the rays at different angles  $\phi$  for incident rays of any frequency. In order that  $I_{\phi=0}$  should remain equal to  $I_0$ , he finds it necessary to suppose that the effective radius of the electron is less for quanta of large frequency or large momentum, by the factor  $1/(1 + \alpha)$ . Since the scattering absorption coefficient per electron is equal to the electron's effective area, this is at once

$$\sigma = \sigma_0 \cdot \frac{1}{(1 + \alpha)^2} \quad (\text{Jauncey}) \quad (9.39)$$

The corresponding intensity of scattering is

$$I_{\phi} = I_0 \cdot \frac{1}{2} \frac{1 + \cos^2 \phi + \alpha(4 + 6\alpha + 4\alpha^2 + \alpha^3) \text{vers}^2 \phi}{(1 + \alpha \text{vers} \phi) \{1 + (\alpha + \frac{1}{2}\alpha^2) \text{vers} \phi\}^4} \quad (9.40)$$

Formulas (9.39) and (9.40) differ from (9.38) and (9.37) respectively only in the second and higher powers of  $\alpha$ . Due to the Fitzgerald contraction, the effective shape of the electron should be altered at high speeds by a term depending on  $\beta^2$  and hence on  $\alpha^2$ . No direct method of calculating this correction has been found; but Jauncey shows that if the shape is made a suitable function of  $\alpha^2$  equations (9.40) and (9.39) may be

changed into the form of (9.37) and (9.38). In the form (9.40), Jauncey's theory, as represented in the dotted line  $J$  of Fig. 120 also falls outside the limits assigned by the correspondence principle. It does not seem improbable, however, that by assuming a suitable alteration with velocity of the the electron's "shape" Jauncey's theory might give an expression falling within these limits.

5. *Breit.* Guided to a large extent by the form of his limiting equation (9.26), Breit has suggested the empirical expression,<sup>1</sup>

$$I_{\phi} = I_0 \frac{1}{2} \frac{1 + \cos^2 \phi}{(1 + \alpha \text{ vers } \phi)^3}. \quad (\text{Breit}) \quad (9.41)$$

This is obviously a kind of mean between (9.23) and (9.26).

The value of  $\sigma$ , calculated by equation (9.35) from Breit's formula for  $I_{\phi}$ , is given by the expression,

$$\left. \begin{aligned} \sigma &= \sigma_0 \cdot \frac{3}{4} \frac{1 + \alpha}{\alpha^3} \left\{ \frac{2\alpha(1 + \alpha)}{1 + 2\alpha} - \log(1 + 2\alpha) \right\} \\ &= \sigma_0 \cdot 3(1 + \alpha) \left\{ \frac{1}{3} - \frac{2}{3}(2\alpha) \right. \\ &\quad \left. + \frac{2}{3}(2\alpha)^2 - \frac{4}{3}(2\alpha)^3 + \dots \right\} \cdot [2\alpha < 1] \end{aligned} \right\} \quad (9.42)$$

To the first order of  $\alpha$  this is identical with equation (9.38), and the precision of the present experiments is probably insufficient to distinguish between the two.

6. *An Alternative Solution.* Breit has shown<sup>2</sup> that a calculation, based on the Doppler principle, of the frequency of the ray scattered in the direction  $\phi$  by an electron recoiling in the direction  $\theta$  with the velocity  $\beta c$  assigned by equation (9.05), gives

$$\frac{\nu''}{\nu} = \frac{1}{(1 + \alpha \text{ vers } \phi)^2} = \left( \frac{\nu'}{\nu} \right)^2.$$

Thus the true modified frequency  $\nu'$  is the geometric mean between the primary frequency  $\nu$  and the frequency  $\nu''$  calculated classically as from the recoiling electrons, i.e.,

$$\nu : \nu' = \nu' : \nu''.$$

<sup>1</sup> G. Breit, *Phys. Rev.* **27**, 242 (1926).

<sup>2</sup> G. Breit, *loc. cit.*

We might reasonably argue that the intensity should likewise be the geometric mean between the classical value  $I_e$  and the value  $I_{\min}$  calculated classically (eq. (9.26)) from the recoiling electrons. That is,

$$I_e : I_\phi = I_e : I_{\min}$$

or

$$\left(\frac{I_e}{I_\phi}\right)^2 = \frac{I_e}{I_{\min}}$$

Using the value of  $I_e/I_{\min} = (1 + \alpha \text{ vers } \phi)^4$  as given by (9.26), and recalling that  $I_e = I_0 \cdot \frac{1}{2}(1 + \cos^2 \phi)$ , we thus have at once,

$$I = I_0 \cdot \frac{1}{2} \frac{1 + \cos^2 \phi}{(1 + \alpha \text{ vers } \phi)^2} \tag{9.43}$$

This represents the simplest possible average of the two limiting values of the intensity assigned by the correspondence principle.

The scattering absorption coefficient calculated from this expression according to equation (9-35) is

$$\sigma = \sigma_0 \cdot \frac{3}{4} \frac{1 + \alpha}{\alpha^2} \left\{ \left( 1 + \frac{1}{2(1 + \alpha)} \right) \log (1 + 2\alpha) - 1 \right\} \tag{9.44}$$

The results of these various methods of calculating the intensity of the scattered X-rays can be grouped in the following manner:

TABLE IX-5

Method	Ratio $I_\phi/I_e$ (Neglecting $\alpha^2, \alpha^3, \dots$ )	Ratio $\sigma/\sigma_0$ (Neglecting $\alpha^2, \alpha^3, \dots$ )
Classical.....	1	1
1. Debye.....	$(1 + \alpha \text{ vers } \phi)^{-1}$	1
6. ....	$(1 + \alpha \text{ vers } \phi)^{-2}$	$(1 + \alpha)^{-1}$
3. Compton } .....	$(1 + \alpha \text{ vers } \phi)^{-2}$ (approx.)	$(1 + 2\alpha)^{-1}$
4. Jauncey } .....		
5. Breit } .....		
Correspondence limit.....	$(1 + \alpha \text{ vers } \phi)^{-4}$	$(1 + 3\alpha)^{-1}$

138. *Experimental Tests*

The most direct test of these various formulas for the intensity of the scattered X-rays is a comparison with experimental values of  $I_\phi$ . Unfortunately it is very difficult to obtain experimental values of this quantity which are sufficiently reliable to be of value for such a test. In the early measurements of Barkla and Ayers,<sup>1</sup> as well as in the more recent ones of Hewlett,<sup>2</sup> comparatively long wave-length X-rays were used, so that departures from the predictions of the classical theory are necessarily small. In a series of experiments performed by the author<sup>3</sup> X-rays of wave-length as short as .13Å were used, for which the departure from the classical values of  $I_\phi$  should have been very appreciable. These measurements are difficult to interpret, however, because of the change in wave-length at different angles. If only a small fraction of the X-rays is absorbed in the ionization chamber, the ionization will be nearly proportional to the absorption coefficient and hence to  $\lambda^3$ , or according to equation (9.04) to  $(1 + \alpha \text{ vers } \phi)^3$ . But this is just the reciprocal (to the first order of  $\alpha$ ) of the reduction in intensity according to theories 3, 4 and 5. It is thus necessary to apply a correction to the measurements of about the same magnitude as the differences in which we are interested. At the present writing no experiments on the intensity of scattered X-rays have been published in which the effect of the change of wave-length has been allowed for with sufficient certainty to make a valuable comparison with the quantum theories.

When hard  $\gamma$ -rays are used the same difficulty remains, but is less prominent because in this region of the spectrum the ionization produced varies only slowly with the wave-length. Experiments by Florance,<sup>4</sup> Kohlrausch<sup>5</sup> and others including the author<sup>6</sup> have shown very prominently the rapid reduction

<sup>1</sup> C. G. Barkla and T. Ayers, *Phil. Mag.* **21**, 275 (1911).

<sup>2</sup> C. W. Hewlett, *Phys. Rev.* **20**, 688 (1922).

<sup>3</sup> A. H. Compton, *Phil. Mag.* **46**, 897 (1923).

<sup>4</sup> D. C. H. Florance, *Phil. Mag.* **20**, 921 (1910).

<sup>5</sup> K. W. F. Kohlrausch, *Phys. Zeits.* **21**, 193 (1920).

<sup>6</sup> A. H. Compton, *Phil. Mag.* **41**, 749 (1921).

in intensity of the scattered  $\gamma$ -rays with increasing angles  $\phi$  in accord with the quantum formulas given above. The quantitative agreement between the results of the different experimenters is not very satisfactory. Perhaps, however, my own measurements are as reliable as any, since an ionization chamber was used that absorbed a large fraction of even the primary  $\gamma$ -rays. The intensities thus measured at different angles are plotted as the dots in Fig. 120.

In accord with the discussion given in Appendix V, we may assume the effective wave-length of these hard  $\gamma$ -rays from radium C to be  $0.017\text{\AA}$ . Thus  $\alpha = 1.42$ . Using this value, curves 0, 1, 2, 3, and 4, represent the 0, 1, 2, 3 and 4th powers respectively of  $1/(1 + \alpha \text{vers } \phi)$ , corresponding to the 5 groups of formulas listed in Table IX-5. The dotted line *J* represents Jauncey's formula (9.40), and the broken line *C* the author's formula (9.37). It will be seen that curves 3 and *C* represent the data in a satisfactory manner, that curves 2, 4 and 5 do not fit so well, and that curves 0 and 1 are wholly out of agreement with the observed intensities.

*The Scattering Absorption Coefficient* affords a more reliable test of the various theories. Its experimental value is the difference between the measured total absorption coefficient and the "true" photoelectric absorption  $\tau$ . The total absorption coefficient is determined by the relative intensities of two beams of the same wave-length, and is measurable with precision. In the case of a light element, for the short wave-lengths with which we are concerned, the photoelectric absorption is responsible for only a small part of the total absorption. For carbon, Hewlett has shown (cf. p. 61, 5) that when  $\lambda = 0.710\text{\AA}$ ,  $\sigma = \sigma_0$ , the value assigned by the classical theory. From the measured value of  $\mu$  for this wave-length, we thus obtain  $\tau_{.710} = \mu_{.710} - \sigma_0$ , and its value for other wave-lengths is given by Owen's rule that  $\tau \propto \lambda^3$ . The scattering absorption coefficient for any wave-length is then given by  $\sigma = \mu - \tau$  (see Appendix VI).

In Fig. 121 are plotted such values of the scattering absorption coefficient in terms of the classical coefficient  $\sigma_0$  as unity.

The dots are taken from data by Hewlett,<sup>1</sup> the open circles from Allen,<sup>2</sup> while + and × refer to measurements of the total absorption of hard  $\gamma$ -rays by Ahmad<sup>3</sup> and by Owen, Fleming and Fage.<sup>4</sup> The solid lines 1, 2 and 3 are the graphs of  $1/(1+\alpha)$ ,

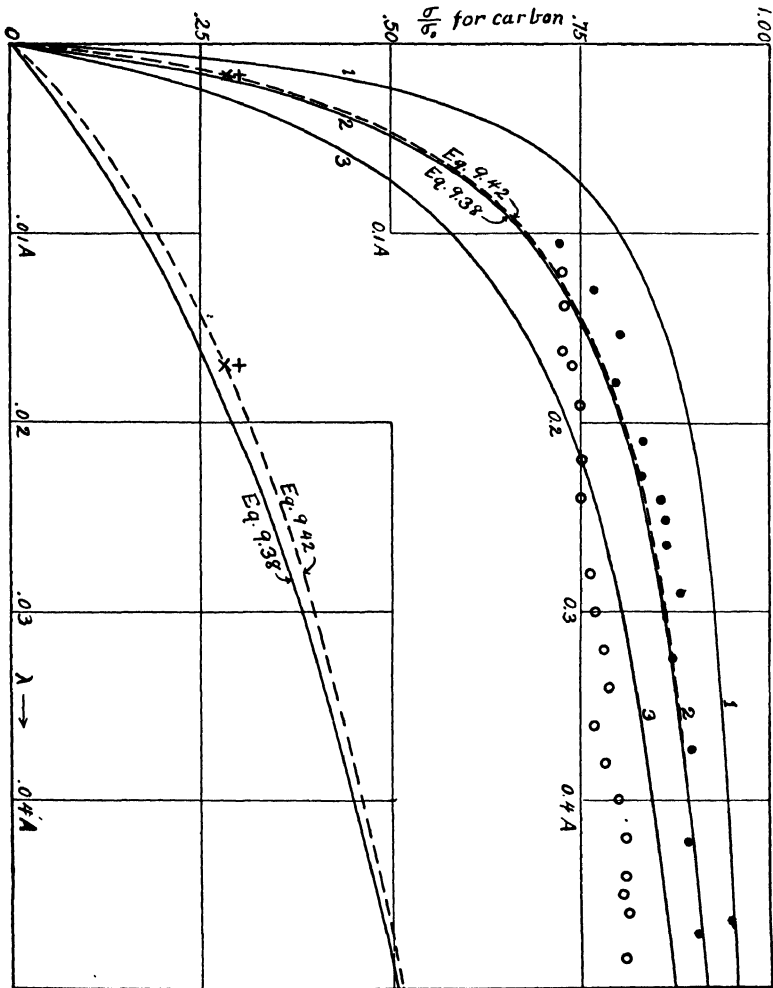

FIG. 121.

<sup>1</sup> C. W. Hewlett, Phys. Rev. 17, 284 (1921).

<sup>2</sup> S. J. M. Allen, Phys. Rev. 24, 1 (1924).

<sup>3</sup> N. Ahmad, Proc. Roy. Soc. 105, 507 (1924); 109, 206 (1925). The datum for carbon is that given in Table VI-3, using  $\lambda = .017\text{A}$  as found in Appendix III.

<sup>4</sup> E. A. Owen, N. Fleming and W. E. Fage, Proc. Phys. Soc. 36, 355 (1924).

$1/(1+2\alpha)$ , and  $1/(1+3\alpha)$ , representing the different theories as classified in table IX-5, page 305. Curve 1 is unquestionably too high, and curve 3 is too low, especially for the shorter wavelengths at which the values of  $\sigma/\sigma_0$  are determined most reliably. The solid curve 2 represents equation (9.38), and the broken curve just above it is plotted from equation (9.42). Throughout the X-ray region these curves are so close together that they are almost indistinguishable on the scale of this figure, and they both fit the experiments within the probable experimental error. In the  $\gamma$ -ray region these two curves are separated farther. This portion of the curves is plotted on a larger wavelength scale in the lower part of the figure, to show more clearly their comparison with Ahmad's and Owen's data. We see that equation (9.42) represents the data somewhat more precisely, though the experimental variations are of the same order of magnitude as the difference between the two curves.

On the basis of the experimental evidence shown in Figs. 9.15 and 9.16 we may accordingly select the two formulas (9.38) and (9.42) as representing most accurately the intensity of the scattered X-rays and the coefficient of absorption due to scattering. The experiments are not sufficiently accurate to distinguish between these two expressions, though they seem to favor the latter. From the theoretical side also the latter formula is preferable, because of the difficulty of reconciling equation (9.37) with the correspondence principle.

### 139. *True Scattering and True Absorption Associated with Scattering*

The intensity of the scattered X-rays and the absorption of X-rays due to scattering which we have been discussing do not afford very significant tests of the quantum hypothesis of the nature of the scattering process. This was to be expected, since in the first place the quantum theory in its present form does not assign a definite value to the intensity of the scattered

rays,<sup>1</sup> and in the second place, we have seen in Chapter III that the departures of the observed intensities from the values predicted by the usual electron theory can be accounted for almost within experimental error by assuming electrons of special form without introducing any quantum concepts. The fact that the experimental intensities fall within the limits assigned by the quantum theory is thus not crucial evidence in favor of this theory.<sup>2</sup>

The quantum theory is however unique in that it predicts a type of *true absorption* associated with the scattering process. Energy spent in setting the recoil electrons in motion does not reappear as X-rays, and hence is truly absorbed; whereas on the classical theory, the only energy spent in the scattering process is that which reappears in the scattered beam. When the quantum theory of scattering was proposed, no such true absorption had been found associated with scattering in the case of X-rays. Ishino had, however, demonstrated the exist-

<sup>1</sup> It is to be hoped that an application of Heisenberg and Born's new quantum mechanics may afford a unique expression for the intensity of the scattered X-rays. Since this hope was expressed, P. A. M. Dirac has successfully attacked the problem of scattering of radiation by free electrons, using the new quantum dynamics (Proc. Roy. Soc., 1926). He obtains equations for the change of wave-length, etc., identical with expression (9.04). For the intensity he finds, apparently as a unique solution, precisely the result suggested by Breit (equation 9.41) from considerations of the correspondence principle. As we note in the text above, this formula agrees very satisfactorily with the experimental results.

Dirac calls attention to a possible crucial test between the type of theory on which his formula (9.41) is based and that leading to such equations as (9.37) and (9.40), since the former theory predicts complete polarization of the scattered rays at  $\phi = 90^\circ$ , whereas the latter theories predict complete polarization at an angle given approximately by  $\cos \phi = \alpha / (1 + \alpha)$ . Dr. Bearden and Mr. Barrett, working in the author's laboratory, have just completed measurements of the angle of maximum polarization. Using X-rays of effective wave-length less than  $.2\lambda$ , which on the earlier forms of quantum theory should give a polarizing angle of about  $83^\circ$ , the experiments gave the maximum polarization at  $90^\circ + 1^\circ$ , in complete accord with the theories of Dirac and Breit.

<sup>2</sup> On page 74, equation 3.12 we showed that diffraction considerations lead to  $I_\phi/I_e = F(\sin \frac{1}{2}\phi/\lambda)$ . Since  $\alpha$  vers  $\phi = 2\alpha \sin^2 \frac{1}{2}\phi = \frac{2h}{mc}(\sin^2 \frac{1}{2}\phi/\lambda)$ , the limiting quantum expression (9.26) gives  $I_\phi/I_e = F'(\sin^2 \frac{1}{2}\phi/\lambda)$ . Experiments sufficiently precise to distinguish between these two functions would afford a more decisive test between the interference and the quantum theories of the X-ray intensities.

ence of true absorption in the case of  $\gamma$ -rays,<sup>1</sup> and there was a strong tendency to associate this true absorption with the scattering.<sup>2</sup> The recent discovery of recoil electrons associated with the scattered rays requires the existence of such true absorption for both X-rays and  $\gamma$ -rays.

Fortunately the quantum theory predicts a rather definite value for this type of true absorption. If  $2\pi r^2 I_\phi \sin \phi d\phi$  is the energy per second scattered between  $\phi$  and  $\phi + d\phi$ , we have seen above (eq. (9-35)) that the energy removed from the primary beam to produce these scattered rays is

$$\frac{\nu}{\nu'} \cdot 2\pi r^2 I_\phi \sin \phi d\phi.$$

The difference between these two quantities,

$$\left( \frac{\nu}{\nu'} - 1 \right) \cdot 2\pi r^2 I_\phi \sin \phi d\phi,$$

is therefore the energy spent in setting in motion the recoil electrons associated with these scattered rays. The coefficient of true absorption due to scattering is thus,

$$\begin{aligned} \sigma_a &= \int_0^\pi \left( \frac{\nu}{\nu'} - 1 \right) \cdot 2\pi r^2 I_\phi \sin \phi d\phi \\ &= 2\pi r^2 \alpha \int_0^\pi I_\phi \text{vers } \phi \sin \phi d\phi. \end{aligned} \quad (9.45)$$

Similarly the coefficient of true scattering may be defined as

$$\sigma_s = 2\pi r^2 \int_0^\pi I_\phi \sin \phi d\phi. \quad (9.46)$$

If we use the value of  $I_\phi$  given by equation (9.37), we obtain from (9.45),

$$\sigma_a = \sigma_0 \cdot \frac{\alpha}{(1 + 2\alpha)^2}, \quad (\text{Compton}) \quad (9.47)$$

<sup>1</sup> M. Ishino, *Phil. Mag.* 33, 140 (1917).

<sup>2</sup> Cf. e.g., A. H. Compton, *Bulletin Nat. Res. Coun. No. 20*, p. 45 (1922). The connection between the true absorption and the scattering of  $\gamma$ -rays had been emphasized earlier by Prof. Rutherford.

and from (9.46),

$$\sigma_s = \sigma_0 \cdot \frac{1 + \alpha}{(1 + 2\alpha)^2}. \quad (\text{Compton}) \quad (9.48)$$

The corresponding expressions using the value of  $I_\phi$  given by equation (9.42) are:

$$\sigma_a = \sigma_0 \cdot \frac{3}{8} \left\{ \frac{2(3 + 7\alpha + 4\alpha^2 - 4\alpha^3)}{\alpha^2(1 + 2\alpha)^2} - \frac{3 + 2\alpha}{\alpha^3} \log(1 + 2\alpha) \right\},$$

(Breit) (9.49)

and

$$\sigma_s = \sigma_0 \cdot \frac{3}{8} \left\{ \frac{1}{\alpha^3} \log(1 + 2\alpha) - \frac{2(1 + 3\alpha - \alpha^3)}{\alpha^2(1 + 2\alpha)^2} \right\}. \quad (\text{Breit}) \quad (9.50)$$

The value of  $\sigma_a$  calculated from the various other quantum formulas for  $I_\phi$  is the same to the first order of  $\alpha$  as equation (9.47), which makes possible a significant test of the quantum theory of scattering.

An experimental test of equation (9.47) in the X-ray region has been made by Fricke and Glasser,<sup>1</sup> by a study of the ionization produced in small ionization chambers by the recoil electrons. They have determined the ratio of the photoelectric absorption  $\tau$  to the scattering true absorption  $\sigma_a$  for two different wave-lengths, and for various materials. The second column of Table IX-6 gives their results for carbon. The agreement with the values in the last column, which they calculate from equation (9.47) with the help of Hewlett's and Allen's absorption data, is rather satisfactory.

TABLE IX-6

RATIO OF PHOTOELECTRIC TO SCATTERING TRUE ABSORPTION BY CARBON  
(Fricke and Glasser)

$\lambda$ , A. U., (Effective)	$\frac{\tau}{\sigma_a}$ Obs.	$\frac{\tau}{\rho}$ $\left\{ \begin{array}{l} \text{Hewlett} \\ \text{Allen} \end{array} \right\}$	$\frac{\sigma_a}{\rho}$ (Eq. 9.47)	$\frac{\tau}{\sigma_a}$ Calc.
0.180	.28	.0065	.0170	.38
0.115	.094	.00172	.0202	.085

<sup>1</sup>H. Fricke and O. Glasser, *Zeits. f. Phys.* **29**, 374 (1924).

In the case of hard  $\gamma$ -rays, the photoelectric absorption, being proportional to  $\lambda^3$ , is negligible compared with the scattering except for the heavy elements. The total scattering absorption  $\sigma$  is measured directly, as described in Chapter VI; the coefficient of true scattering  $\sigma_s$  is determined by measuring with an ionization chamber the fraction of the incident rays that reappear as scattered  $\gamma$ -rays, and the coefficient of true absorption  $\sigma_a$  is given by

$$\sigma_a = \sigma - \sigma_s. \quad (9.53)$$

According to any wave theory of scattering,  $\sigma_s = \sigma$ , and  $\sigma_a = 0$ .

Measurements of  $\sigma$ ,  $\sigma_s$  and  $\sigma_a$ , using the hard  $\gamma$ -rays from RaC, have been made by Ishino,<sup>1</sup> and by Owen, Fleming and Fage.<sup>2</sup> The refinements in experimental technique introduced by the latter investigators make their results deserve greater weight than the earlier experiments of Ishino. The data for carbon are shown in Table IX-7. The agreement between the values of  $\sigma_a/\sigma$ , shown in the last column, is of especial significance, since the theoretical value of  $\sigma_a/\sigma$  is almost independent of the form

TABLE IX-7

MASS SCATTERING COEFFICIENTS OF ALUMINIUM FOR HARD  $\gamma$ -RAYS FROM RaC

Authority	Total Scattering Absorption, $\sigma$	True Scattering $\sigma_s$	True Absorption, $\sigma_a$	$\frac{\sigma_a}{\sigma}$
Ishino*	.066	.045	.021	.32
O. F. & F.	.0559	.0352	.0207	.370
Eqs. 9.38, 9.48 and 9.47 ( $\lambda = .017$ )	.0500	.0325	.0185	.370
Eqs. 9.42, 9.50 and 9.49 ( $\lambda = .017$ )	.0545	.0364	.0171	.333

\* Ishino's values have been corrected for a slight error in calculation.

<sup>1</sup> M. Ishino, *Phil. Mag.* **33**, 140 (1917).

<sup>2</sup> E. A. Owen, N. Fleming and W. E. Fage, *Proc. Phys. Soc.* **36**, 355 (1924).

of the quantum theory adopted, but differs widely from the value 0 predicted by any form of wave theory.

Our investigation of the intensity of X-ray scattering from the standpoint of the hypothesis of radiation quanta therefore gives results which, as far as they go, are completely confirmed by experiment. It is true that in the present form of the quantum theory the intensity of the scattered X-rays is defined only by rather wide limits. But the experimental intensities are found to fall within these limits, and the quantum theory predicts just the kind of departures from the classical theory that are observed. Where the theory does make quantitative predictions differing from the predictions of the wave theory, as in the case of the true absorption associated with scattering, the predictions are completely confirmed by experiment. *Thus regarding intensities as well as regarding wave-lengths the quantum theory of scattering finds itself established on a firm experimental basis.*

Further experiments on the intensities of scattered X-rays of short wave-length are however much to be desired, in order to enable us to select the appropriate form of the correspondence principle to apply to the scattering problem.

## CHAPTER X

### QUANTUM THEORY OF X-RAY DIFFRACTION

#### 140. *The Quantum Conditions*

In Chapter I we introduced the assumption, made first by Bohr, that the angular momentum of a revolving electron is an integral multiple of  $h/2\pi$ , where  $h$  is Planck's constant. This is an example of a more general statement of the quantum conditions,<sup>1</sup> that

$$\int_{q_0}^{q_1} p dq = nh. \quad (10.01)$$

Here  $q$  is the "displacement" along the coordinate used to define the motion,  $p$  is the momentum along this coordinate, and  $n$  is an integer. The limits of integration are so chosen that the condition of the system at  $q_1$  is indistinguishable regarding its  $q$  coordinate from its condition at  $q_0$ . Thus for a rotating system,  $q$  is the angle through which the system has turned,  $p$  is the angular momentum, and  $q_0$  and  $q_1$  may be taken as 0 and  $2\pi$ . If the angular momentum is a constant, we have,

$$\int_0^{2\pi} p dq = p \int_0^{2\pi} dq = 2\pi p,$$

or by equation (10.01),

$$p = nh/2\pi, \quad (10.02)$$

which was Bohr's assumption.

<sup>1</sup>This statement of the quantum conditions is developed by Sommerfeld in his "Atomic Structure and Spectral Lines" (English edition, p. 193). The rule as thus stated gives the correct results only when the proper coordinates (usually the most obvious ones) are chosen to describe the motion. An alternative statement of the standard quantum conditions which avoids the difficulty of selecting the proper coordinates has been proposed by Schwarzschild and developed by Bohr. The formulation of the quantum conditions is discussed thoroughly by J. H. VanVleck in his "Quantum Principles of Line Spectra," Bulletin of the National Research Council, 1926.

Imagine an infinite succession of points arranged along the  $X$  axis, spaced at equal distances  $D$  and moving with constant momentum  $p$ . Then in expression (10.01),  $q = x$ , and, since after moving through a distance  $D$  the position of the system is indistinguishable from its original position, we may take the limits of integration as 0 and  $D$ . Thus,

$$\int_{q_0}^{q_1} p dq = p \int_0^D dx = pD = nh,$$

whence the momentum is defined by

$$p = nh/D. \quad (10.03)$$

#### 141. *Bohr's Frequency Condition*

Let us apply this result to an infinite train of plane waves of wave-length  $\lambda$ , propagated with velocity  $c$  along the  $X$  axis. Equation (10.03) then becomes at once,  $p = nh/\lambda$ , or since the energy of the wave train is  $W = pc$ ,

$$W = nhc/\lambda = nh\nu. \quad (10.04)$$

Thus changes in the energy of the wave train must occur in integral multiples of  $h\nu$ . If we suppose that for a simple sine wave, with no harmonics,  $n$  is always 1, we have at once for the energy of the wave train,

$$W = h\nu, \quad (10.05)$$

which expresses Bohr's frequency condition, and is the basis of Einstein's photoelectric equation. In terms of momentum instead of energy, this is, as we have seen before,

$$p = W/c = h/\lambda. \quad (10.06)$$

In view of the evidence, presented in the last chapter, that when a quantum of radiation is emitted it proceeds in a definite direction, it is unnecessary to consider any type of wave other than a long train of plane waves. For the only form of wave which transmits energy in a definite direction is a plane wave,

and in order that the wave shall have a definite frequency it must occur in long trains. Thus a directed quantum of definite energy or momentum corresponds on the classical theory to a long train of plane waves, such as we have considered. There is apparently no way in which such a long wave train can give up a whole quantum of energy to an atom in a time interval short compared with the period of the wave, as has seemed necessary (Chapter VIII) in order to account for the unsymmetrical emission of photoelectrons, unless the energy and momentum of the wave are localized in certain points of the wave train. Such a conception, however, departs radically from the characteristics of the classical electromagnetic waves.

#### 142. *Diffraction by a Crystal*<sup>1</sup>

Consider now a crystal as in infinite succession of similar atomic layers, perpendicular to the  $Y$  axis, and spaced at

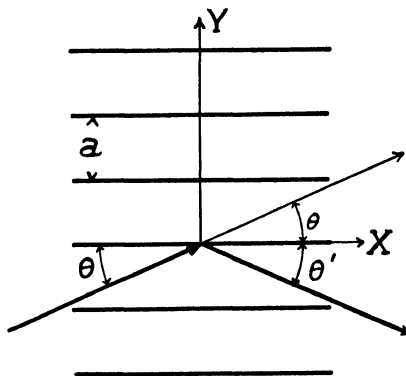

FIG. 122.

distances  $a$  apart, as illustrated in Fig. 122. If this crystal moves along the  $Y$  axis, its position after moving a distance  $a$  is indistinguishable from its original position. For uniform linear motion along the  $Y$  axis,  $p$  is the constant momentum,

<sup>1</sup> W. Duane, Proc. Nat. Acad. Sci. 9, 159 (1923). A. H. Compton, Ibid. 9, 359 (1923).

and  $\int dq = a$ , as we have just seen. As in equation (10.03),  $p$  is then defined by the relation

$$p = nh/a. \quad (10.07)$$

Consider the motion of the crystal illustrated in Fig. 122 when it is traversed by an X-ray quantum whose momentum is  $h/\lambda$ . Let  $\theta$  be the glancing angle of incidence and  $\theta'$  that of the diffracted beam. We shall first take the case in which the only impulse imparted to the crystal is along the  $Y$  axis. Then conservation of momentum along the  $X$  axis gives,<sup>1</sup>

$$\frac{h}{\lambda} \cos \theta = \frac{h}{\lambda'} \cos \theta',$$

whence

$$\theta' = \pm \theta.$$

The case  $\theta' = +\theta$  represents a ray traversing the crystal without deviation, so that no momentum is imparted to the crystal. The case  $\theta' = -\theta$  is that pictured in Fig. 122. According to equation (10.07) the impulse given the crystal along the  $Y$  axis is  $\pm nh/a$ , and the expression for the conservation of momentum along this axis becomes

$$\frac{h}{\lambda} \sin \theta = -\frac{h}{\lambda} \sin \theta \pm \frac{nh}{a},$$

whence

$$n\lambda = 2a \sin \theta, \quad (10.08)$$

which is Bragg's law as stated in equation (1.03).

### 143. Diffraction by an Infinite Simple Cubic Crystal<sup>2</sup>

If  $a$  is the distance between the layers of atoms as measured along the  $X$ ,  $Y$  or  $Z$  axes, we obtain, just as in deriving equation

<sup>1</sup> The wave-length of the quantum is unchanged, since the energy gained by so massive a body as a crystal, due to the impulse imparted by the quantum, is negligible compared with the energy of the quantum. Thus, according to equation 9.04, the change of wave-length is inversely proportioned to the mass of the system which deflects the ray.

<sup>2</sup> W. Duane, loc. cit., A. H. Compton, loc. cit., and P. Epstein and P. Ehrenfest, Proc. Natl. Acad. 10, 133 (1924).

(10.03), that the impulses imparted to the crystals along these axes will be respectively,

$$\Delta p_x = n_x h/a, \quad \Delta p_y = n_y h/a, \quad \Delta p_z = n_z h/a. \quad (10.09)$$

Let  $\alpha, \beta, \gamma$ , be the direction cosines of the incident ray, and  $\alpha', \beta', \gamma'$ , those of the diffracted ray. The increase in the  $X$  component of the momentum of the quantum of radiation when diffracted is  $\frac{h}{\lambda}\alpha' - \frac{h}{\lambda}\alpha$ . This change in the momentum must be balanced by the change in the momentum of the crystal, i.e.,

$$\frac{h}{\lambda}\alpha' - \frac{h}{\lambda}\alpha + \frac{h}{a}n_x = 0.$$

Thus for the three different axes we obtain

$$\alpha - \alpha' = n_x \frac{\lambda}{a}, \quad \beta - \beta' = n_y \frac{\lambda}{a}, \quad \gamma - \gamma' = n_z \frac{\lambda}{a}. \quad (10.10)$$

These expressions for the angles at which the ray of wavelength  $\lambda$  may be diffracted by a crystal are exactly those obtained much less simply on the theory of interference.

Equations (10.10) may be put in a more familiar form by noting that if  $\theta$  is half the angle between the incident and the diffracted ray, we have from trigonometry,

$$\sin \theta = \frac{1}{2} \sqrt{(\alpha - \alpha')^2 + (\beta - \beta')^2 + (\gamma - \gamma')^2},$$

whence by equation (10.10),

$$2 \sin \theta = \frac{\lambda}{a} \sqrt{n_x^2 + n_y^2 + n_z^2}.$$

But the integers  $n_x, n_y, n_z$  are components of a vector in the direction of the momentum imparted to the crystal, and hence of a vector normal to the atomic layers which "reflect" the ray. We have seen above (eq. (4.03a)) that the Miller indices ( $h, k, l$ ) of these atomic layers are the smallest integers propor-

tional to the direction cosines of their normal. It follows that

$$\frac{n_x}{h} = \frac{n_y}{k} = \frac{n_z}{l} = n, \text{ where } n \text{ is some integer. Thus}$$

$$2 \sin \theta = \frac{n\lambda}{a} \sqrt{h^2 + k^2 + l^2}.$$

Now the distance between successive  $(h, k, l)$  planes is given by equation (4.06) as

$$D = a/\sqrt{h^2 + k^2 + l^2}.$$

We thus have for this more general case,

$$n\lambda = 2D \sin \theta,$$

which is again Braggs' law.

#### 144. *Other Diffraction Problems*

When a crystal grating of finite dimensions is considered, both the wave theory and the quantum theory may proceed by treating the crystal as a Fourier integral of infinite gratings. The diffraction by each grating may be determined by the method used above for the infinite cubic grating. In order, however, to calculate on the quantum basis the relative intensity of the rays diffracted by the different component gratings, some additional assumption is necessary. This additional assumption is supplied by Bohr's "correspondence principle," according to which the intensity predicted by the quantum theory should be an average of the intensities predicted by the classical theory for the initial and final states. In the present case, to avoid Doppler effects, we choose the initial state as the diffraction by the crystal at rest, and the final state is then the diffraction by the crystal moving with the momentum  $nh/D$ . This means a velocity so slow that the intensity is practically the same as that for a crystal at rest. According to the correspondence principle, therefore, the intensities of the diffracted rays should be those calculated from the classical theory.

When considering the intensity of crystal diffraction from the classical standpoint, we found it proportional to the

square of the structure factor  $F$  (see eq. 5-16). But for any given order of diffraction  $n$ ,  $F_n$  was found to be (eq. 5-42) proportional to the amplitude of the  $n$ th harmonic of the Fourier series (eq. 5-41) that represents the density of the crystal. It follows, on the quantum theory, that the probability that a quantum shall be diffracted in the  $n$ th order (i.e., impart momentum  $nh/D$  to the crystal) is proportional to the square of the amplitude of the  $n$ th term of the series expressing the crystal density. On this basis Breit<sup>1</sup> and Epstein and Ehrenfest<sup>2</sup> have shown that the predictions of the present form of quantum theory of crystal diffraction are identical with those of the wave theory.<sup>3</sup> In fact, the latter authors show that with the help of this consequence of the correspondence principle *all problems of Fraunhofer diffraction may be solved according to the present form of quantum theory.*

#### 145. *What is the "Frequency" of a Quantum?*

In accounting for photoelectrons, recoil electrons, the diffraction of X-rays by crystals, etc., the only properties that we have assigned to the radiation quantum are energy, momentum and a characteristic direction or axis along which it may act on an electron. Nothing has been said about its frequency, except that its energy and momentum are stated in terms of the frequency of the corresponding wave. It is, however, open to question whether there is anything that can properly be called a wave when we consider radiation so feeble that quanta are emitted only at infrequent intervals.

The use of the terminology of the wave theory is not at all necessary in discussing spectroscopic phenomena. When a hydrogen atom radiates an  $H\alpha$  line, we say with Bohr in terms of waves that the atom has changed from the stationary state for which  $n = 3$  to that for which  $n = 2$ , and that the energy re-

<sup>1</sup> P. Breit, Proc. Nat. Acad. 9, 238 (1923).

<sup>2</sup> P. Epstein and P. Ehrenfest, Proc. Nat. Acad. 10, 133 (1924).

<sup>3</sup> It was by this method also that Duane, following the results of Epstein and Ehrenfest, originally derived equation 5.48, which we have obtained from classical calculations.

leased is radiated in waves of frequency  $\nu = W/h$ . This *frequency* we may determine by measuring the angle at which the ray is diffracted by a transmission grating of known grating space, calculating from the simple formula,

$$\nu = nc/D \sin \theta,$$

which follows from the fact that the wave-length is  $\lambda = c/\nu$ , and the result of interference principles that

$$n\lambda = D \sin \theta.$$

The event may however be described equally well in the language of the quantum theory. When the hydrogen atom changes from state 3 to state 2, the difference in energy  $W$  is radiated as a single quantum. This *energy* we may determine by measuring the angle at which the ray is diffracted by a transmission grating of known grating space, calculating from the simple formula,

$$W = nhc/D \sin \theta,$$

which follows from the fact that the momentum of the quantum is  $p = W/c$ , and the result of the quantum postulate and the conservation of momentum that,

$$p \sin \theta = nh/D.$$

This example illustrates the fact that for spectroscopic work the term "frequency" is merely a convenient abbreviation for the ratio  $W/h$ , and that nothing essential is missed if we omit the term. Such a point of view avoids the very serious difficulty, inherent in the wave theory, of explaining how a wave of definite frequency  $\nu$  is radiated when there is no oscillator of this frequency within the atom. It is the radiated *energy* which is of importance; there is no evidence that *frequency* in the strict sense is a property of individual radiation quanta.

There is nothing incompatible between this conclusion and the suggestion that intense radiation of quanta of small energy

may assume a wave form. It is reasonable to think of such radiation as consisting of successive sheets of quanta. A simple calculation shows that even a comparatively feeble electric wave of the type used in wireless communication would have a large number of energy quanta per cubic centimeter. We are thus led to suggest that intense radiation consists of waves composed of successive layers of corpuscular quanta, whereas feeble radiation consists of isolated quanta so far apart that no wave structure is apparent.

## CHAPTER XI

### X-RAY SPECTRA

#### 146. *X-ray Spectra as a Test of Bohr's Theory*

It was fortunate for the progress of Physics that when Bohr proposed his theory of atomic structure a method had been developed for the study for X-ray spectra. The remarkable agreement of Moseley's original X-ray spectra with the predictions of Bohr's theory was probably largely responsible for the almost universal favor with which that theory was received. We have seen in the introductory chapter of this book how Moseley's spectra, when interpreted in the light of Bohr's theory, showed that as one goes from one atom to the next in the order of atomic weights the charge on the nucleus increases by one electronic unit. Probably the most essential part of Bohr's theory is, however, the introduction of the concept of stationary states, and the hypothesis that each spectrum line is due to the quantum of energy radiated when the atom changes from one stationary state to another of lower energy. Similarly when the atom absorbs energy it takes up just enough to raise it to a new stationary state with higher energy. Through whatever vicissitudes Bohr's theory may pass, it seems that this conception of stationary states must persist. When studying X-ray spectra we are able in many cases to measure directly the energy of these stationary states, and hence to compare the energy of the emitted quanta with the energy differences between these states. The success of this test justifies confidence in Bohr's view of the origin of the spectral lines.

## MEASUREMENTS OF X-RAY WAVE-LENGTH

147. *The Grating*

In order to serve as an adequate test of spectral theories, it is often important that the wave-length of a spectral line be measured with great precision. We have seen that the wave-length may be measured either by reflection from a crystal, or by reflection from a grating ruled on a polished surface of glass or metal. At the present writing, the measurements that have been made of X-ray wave-lengths with a ruled grating are not as precise as the crystal determinations. They serve only to show that the crystal measurements are reliable to within about a per cent. This is however important in that it establishes the correctness of the crystal lattice on which is based our calculation of its grating space.

The wave-length of the X-rays is usually calculated from the crystal measurements by use of Bragg's equation,

$$n\lambda = 2D \sin \theta, \quad (11.01)$$

where  $n$  is the order of reflection,  $D$  is the distance between successive layers of atoms, and  $\theta$  is the complement of the angle of incidence. As we noticed in Chapter VII, a more precise expression for the wave-length is

$$n\lambda = 2D \sin \theta \left( 1 - \frac{\delta}{\sin^2 \theta} \right), \quad (11.02)$$

where  $\delta = 1 - \mu$ , and  $\mu$  is the index of refraction of the X-rays in the crystal. When the X-rays used are of considerably higher frequency than the  $K$  absorption frequency of the heaviest atom in the crystal we may write equation (11.02) in the simple form (cf. eq. 7.20),

$$n\lambda = 2D' \sin \theta, \quad (11.03)$$

where  $D'$  has the value

$$D' = D \left( 1 - \frac{b}{n^2} \right), \quad (11.04)$$

and  $b$  is approximately a constant, with the value

$$b = \frac{2se^2D^2}{\pi mc^2}, \quad (11.05)$$

$s$  being the number of electrons per unit volume.

Using the present spectroscopic technique, it is possible to measure  $\theta$  and  $\delta$  with accuracy that by far the greater part of the error in determining the absolute wave-length of a beam of X-rays is due to the uncertainty of  $D$ .

From very fundamental considerations of crystal structure it can be shown that the grating space of a rhombohedral crystal is given by

$$D = \left\{ \frac{nM}{\rho N \phi(\beta)} \right\}^{1/2}, \quad (11.06)$$

where  $n$  is the number of molecules in each elementary rhombohedron,  $M$  is the molecular weight,  $\rho$  the density,  $N$  the number of molecules per gram molecule, and  $\phi(\beta)$  is the volume of a rhombohedron the distance between whose opposite faces is unity and the angle between whose edges,  $\beta$ , is that between the axes of the crystal. It can be shown that

$$\phi(\beta) = \frac{(1 + \cos \beta)^2}{(1 + 2 \cos \beta) \sin \beta}. \quad (11.07)$$

The values of the grating spaces of calcite and rock-salt, the two crystals most commonly used for absolute wave-length determinations, can be calculated from equation (11.06), using the following values of the constants:

For calcite,	For rock-salt,
$n = \frac{1}{2}$ <sup>1</sup>	$n = \frac{1}{2}$ <sup>1</sup>
$M = 100.70 \pm .02$ <sup>2</sup>	$M = 58.455 \pm .02$ <sup>2</sup>
$\rho = 2.7102 \pm .0004$ at $20^\circ$ <sup>3</sup>	$\rho = 2.1632 \pm .0004$ at $20^\circ$ C. <sup>3</sup>
$N = (6.061 \pm .006) \times 10^{23}$ <sup>4</sup>	$N = (6.061 \pm .006) \times 10^{23}$ <sup>4</sup>
$\beta = 101^\circ 55'.1 \pm .2'$ <sup>5</sup>	$\beta = 90^\circ$
$\phi(\beta) = 1.09630 \pm .00007$ <sup>5</sup>	$\phi(\beta) = 1.$

We thus obtain,

$$D_{(\text{CaCO}_3)} = (3.0288 \pm .0010) \times 10^{-8} \text{ cm. at } 20^\circ \text{ C.}$$

$$D_{(\text{NaCl})} = (2.8144 \pm .0009) \times 10^{-8} \text{ cm. at } 20^\circ \text{ C.}$$

<sup>1</sup> W. H. Bragg and W. L. Bragg, "X-Rays and Crystal Structure" (1915).

<sup>2</sup> International Critical Tables, v. 1, p. 43 (1926). The estimates of the accuracy are based chiefly upon the data collected by F. W. Clarke, "A Recalculation of Atomic Weights" (1920).

<sup>3</sup> O. K. DeFoe and A. H. Compton, Phys. Rev. 25, 618 (1925).

<sup>4</sup> International Critical Tables, v. I, p. 18 (1926).

<sup>5</sup> H. N. Beets, Phys. Rev. 25, 621 (1925).

The thermal expansion coefficient of these crystals, though not large, are sufficient to make corrections necessary for precise measurements. Perpendicular to the cleavage faces this coefficient is for calcite<sup>1</sup> 0.0000104 and for rock-salt<sup>2</sup> 0.0000404 per degree centigrade. If we use the value 3.02880 as the value of the grating space of calcite, and 2.81440 as that of rock-salt at 20° C., their values at other temperatures are given in the following table.

TABLE XI-1

GRATING SPACE OF CALCITE AND ROCK-SALT AT DIFFERENT TEMPERATURES

<i>T</i>	<i>D</i> (CaCO <sub>3</sub> )	<i>D</i> (NaCl)
15° C.	3.02864 <i>A</i>	2.81383 <i>A</i>
16	868	395
17	871	406
18	874	417
19	877	429
20	(3.02880)	(2.81440)
21	883	451
22	886	463
23	889	474
24	893	485
25	3.02896	2.81497

Siegbahn has made a precise comparison of the grating spaces of these two crystals by comparing the angles at which they reflect certain spectrum lines.<sup>3</sup> He finds for the value of  $D(\text{CaCO}_3)/D(\text{NaCl})$  at 18° C., 1.076417. This comes almost within the probable error of the ratio of the two calculated values, taken from Table XI-1,  $1.0762 \pm .0002$ .

For measurements of X-rays of wave-lengths greater than 3A, crystals of larger grating space are usually used. Some of the more common ones are:

<sup>1</sup> M. Siegbahn, "Spektroskopie der Roentgenstrahlen," p. 86 (1924).

<sup>2</sup> Fizeau. Cf. Landolt, Bornstein, Roth, "Tabellen," p. 336 (1912).

<sup>3</sup> M. Siegbahn, Phil. Mag. 37, 601 (1919).

TABLE XI-2

Crystal	Grating Space	Authority
Gypsum.....	7 578A	Hjalmar Stenstrom
Sugar.....	10 57	Pauling and Bjorksen
$\beta$ Alumina.....	11.23	Thoraues and Siegbahn
Palmitic Acid....	35 595	

148. *Typical X-ray Spectra*

In an earlier chapter we have described briefly the construction of the X-ray spectrometer, and have given examples of the ionization and the photographic spectra obtained. For pre-

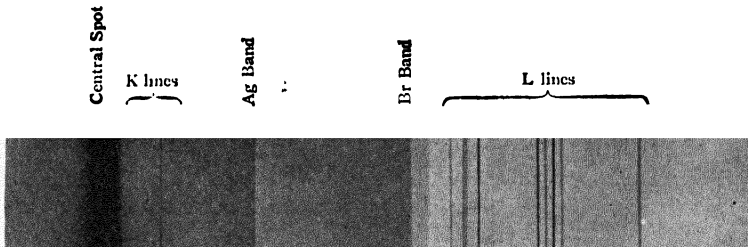

FIG. 123.

cision wave-length measurements either the ionization or the photographic method may be used, though the photographic method is better adapted for use with the greater wave-lengths. An excellent description of various forms of precision spectrometers and of X-ray tubes designed especially for spectroscopic work may be found in Siegbahn's "The Spectroscopy of X-Rays." As typical spectra, we may show de Broglie's beautiful photograph<sup>1</sup> of the complete spectrum of the *K* and *L* series of tungsten (Fig. 123), and the author's ionization spectrum of tungsten, showing two orders of the *L* series.<sup>2</sup>

<sup>1</sup> M. de Broglie, *J. de Phys.*, 1916.

<sup>2</sup> A. H. Compton, *Phys. Rev.* 7, 646 (1916).

Siegbahn gives the following interesting summary of determinations of the wave-length of the  $K_1$  line of copper, to illustrate the increase in precision of measurements of X-ray spectra:

TABLE XI-3

Moseley (1913).....	1.549 A	.012
Siegbahn-Stenstrom (1916).....	1.539	.002
Siegbahn (1918).....	1.53736	.0001
Siegbahn (1922).....	1.53730	.00004
Siegbahn (1924).....	1.53726	.....

From this table we see that the probable error in the measurement of X-ray wave-lengths can be reduced to about 1 part in

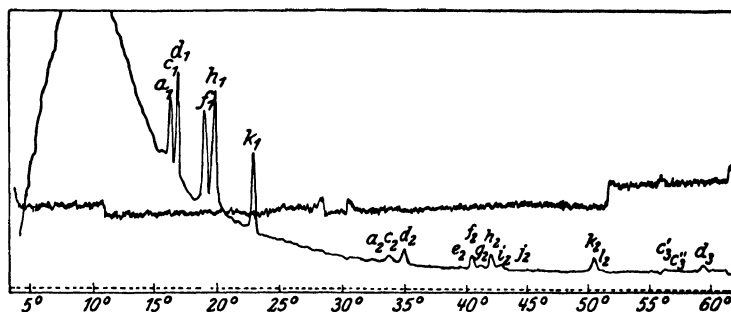

FIG. 124.

a hundred thousand. This is however only the "relative" error. A much larger probable error is present in the absolute value of the wave-length because of the uncertainty of the crystalline grating space. Siegbahn and his coworkers have assumed as a standard, 2,81400A for the grating space of rock-salt, from which, by spectrometric comparison, he has obtained 3.02904A (at 18°) for the grating space of calcite. Many other investigators, including Duane, use as the standard 3.02800A for the grating space of calcite.

Tables of the wave-lengths of the various emission lines that have been measured are given in Appendix IV.

149. *Classification of X-ray Spectra*

Perhaps the two most prominent properties of the X-ray spectra are the fact that for any one element the lines group themselves into distinct series, such as the *K* and *L* series shown so well in de Broglie's photograph of Fig. 123, and the regular decrease in wave-length of each spectrum line as one proceeds to elements of higher atomic number, as expressed by Moseley's law. Fig. 125, drawn using the data shown in Table VI-7, exhibits both of these properties. Here has been plotted  $\sqrt{\nu/R}$  against *Z*, where  $\nu$  is the frequency  $c/\lambda$  of the various critical absorption limits, *R* is the Rydberg constant,  $3.2775 \times 10^{15}$  sec.<sup>-1</sup>, and *Z* is the atomic number. The different absorption limits mark the positions of the various series, while the fact that the lines joining the experimental wave-lengths are almost straight is in accord with Moseley's law,

$$\nu^{1/2} = K(Z - k) \quad (11.08)$$

(see eq. 1.04).

According to Bohr's theory, as described in Chapters I and X, a quantum of X-rays is emitted when an atom changes from one stationary state to another with less energy. Rather direct evidence that within the atom exist electrons with various definite amounts of energy is afforded by the fact that photoelectrons ejected by homogeneous X-rays occur in definite velocity groups, differing from each other according as the work differs in removing the electrons from different parts of the atom. We have seen that the energies of the various levels estimated from the velocities of the photoelectrons agree with the energies calculated from the critical absorption wave-lengths. It is thus natural to assume that the energy levels between which an electron moves when a quantum of X-rays is emitted also have the values corresponding to the critical absorption wave-lengths.

As a test of this suggestion, we may consider the *K $\alpha$*  lines of tungsten. These lines we suppose are due to atoms whose electrons fall into the *K* energy level from the next higher, or *L*

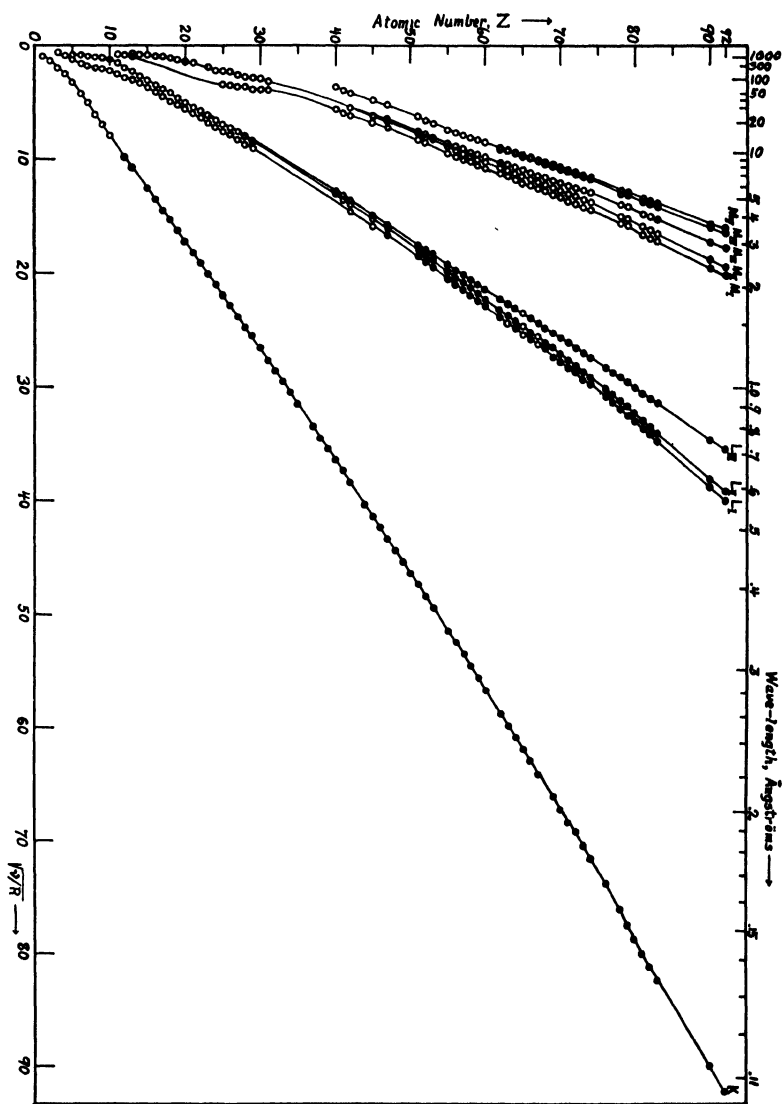

FIG. 125.

energy levels. If  $\lambda_K$  is the wave-length of the critical  $K$  absorption,  $\lambda_{L_{III}}$  that of the critical  $L_{III}$  absorption, etc., the corresponding energies of the levels are  $h \times c/\lambda_K$ ,  $hc/\lambda_{L_{III}}$ , etc. Thus the wave-length of the resulting  $K\alpha_1$  line is given by

$$-\frac{hc}{\lambda_{K\alpha_1}} = hc \left\{ \frac{1}{\lambda_{L_{III}}} - \frac{1}{\lambda_K} \right\},$$

the minus sign occurring because the energies of the orbits are negative, or

$$\frac{1}{\lambda_{K\alpha_1}} = \frac{1}{\lambda_K} - \frac{1}{\lambda_{L_{III}}}. \quad (11.09)$$

In terms of the *wave-number*, or reciprocal of the wave-length, this result becomes merely,

$$\nu_{K\alpha_1} = \nu_K - \nu_{L_{III}}. \quad (11.10)$$

Using the wave-lengths determined by Duane and his collaborators,<sup>1</sup> we find the following results.

TABLE XI-4

CALCULATED AND OBSERVED WAVE-LENGTHS OF THE TUNGSTEN  $K$  LINES

$K$ absorption	$L$ absorption	$K$ calculated	$K$ observed
.17806A	III. 1.2136A	$a_1$ .20867A	.20860A
	II. 1.0726A	$a_2$ .21350	.21341
	I. 1.024	$a_3$ .2155	.215

It will be seen that within the probable accuracy of the experiments the experimental values of the wave-lengths agree with those calculated from the observed energy levels.

### 150. Energy Level Diagrams

In a similar way, it is found that the wave-numbers of the other lines of the  $K$  series, and those of the  $L$  and  $M$  series of tungsten as well, can be calculated from relation (11.10) as the

<sup>1</sup> W. Duane, Bulletin Nat. Res. Council No. 1, November, 1920.

difference between the wave-numbers of two energy levels. This is illustrated graphically by the energy level diagram for the element uranium, shown in Fig. 126. The line drawn from  $N_{III}$  to  $L_{III}$  represents for example the passage of an electron from the  $N_{III}$  to the  $L_{III}$  energy level, and giving rise to the  $L_2$  line.

It is found that nearly all of the observed X-ray spectrum lines can be described as due to transfers between  $1K$  energy

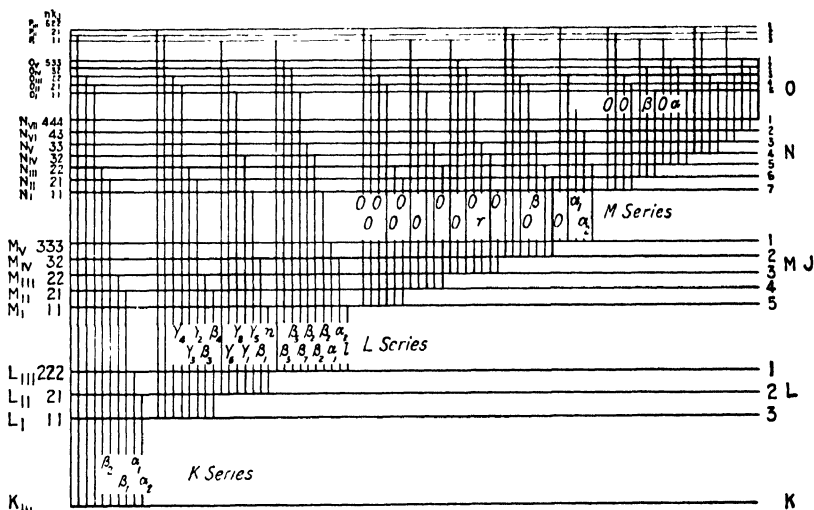

FIG. 126.

level, 3L levels, 5M levels, 7N levels, 5O levels and 1P level.<sup>1</sup> For the lighter elements the number of outer levels is reduced.

### 151. The Selection Rule

We do not, however, find spectrum lines whose wave-numbers correspond to all possible transfers. Thus, for example, we find  $K\alpha_1$  and  $K\alpha_2$  lines, resulting from transfers from the  $L_{III}$  and the  $L_{II}$  levels respectively to the  $K$  level; but except

<sup>1</sup> The few faint lines which are not thus described are explicable as due either to electrons which start from levels in which electrons are not found in the normal atom, or to changes of the energy of the levels due to multiple ionization of the atom.

under unusual conditions no  $K\alpha_3$  line, corresponding to a transfer from the  $L_I$  to the  $K$  level, is observed. It is found possible to state a rule in terms of three numbers according to which transfers occur. These three numbers are frequently called the *principle quantum number*  $n$ , the *auxiliary quantum number*  $k$ , and the *inner quantum number*  $j$ . For the  $K$  levels  $n = 1$ , for the  $L$  levels  $n = 2$ , etc. The auxiliary number  $k$  may have any integral value between 1 and  $n$ . The inner quantum number  $j$  may be equal either to  $k$  or to  $k-1$ . Each level thus has its own characteristic value of  $n$ ,  $k$  and  $j$ . The *selection rule* may then be stated as follows:  $n$  changes from a larger to a smaller number,  $k$  changes by  $\pm 1$ , and  $j$  changes by  $\pm 1$  or 0 whenever an electron is transferred from one energy level to another. The lines drawn in Fig. 126 are based on this rule, those transfers marked by letters indicating observed lines. Occasionally, however, faint lines are observed, such as the tungsten  $K\alpha_3$  line, which are not permitted by this selection rule.

### 152. Regular and Irregular Doublets

From the form of the energy level diagram it is evident that many of the spectrum will occur as doublets. Thus corresponding to the energy difference between the  $L_{II}$  and the  $L_{III}$  levels we have the following doublets, all of which are separated by the same difference in energy, and hence the same difference in wave-number:  $K\alpha_1-K\alpha_2$ ;  $L_{II}-L_I$ ,  $L\beta_1-L\alpha_2$ ,  $L\gamma_5-L\beta_2$ ,  $L\gamma_8-L\beta_7$ . The observed values of the differences of these wave-numbers are found to be identical within experimental error. Doublets of this type are due to the difference in energy between two levels having the same principle quantum number and the same auxiliary quantum number, but differing in the inner quantum number by 1. They are sometimes described as "regular" doublets, in view of the fact that the wave-length difference between the two lines in such doublets is very nearly the same for all elements.

There is another type of doublet corresponding to the difference in energy between two levels which differ only in their

auxiliary quantum number. The  $L_{II}$  and  $L_I$  absorption limits represent such a doublet. Because of the fact that these doublets differ in wave-length as one goes from one element to another, they have been called "irregular" doublets. It was noticed by Hertz, however, that for these doublets the difference between the square roots of the wave-numbers of the two lines is nearly the same for all elements. Their appellation "irregular" is thus rather a misnomer.

### 153. *Interpretation of the X-ray Spectra*

We noticed in the first chapter that many of the major characteristics of the X-ray spectra, as observed by Moseley, follow at once from a simple form of Bohr's theory of atomic structure. Thus not only did we derive Moseley's law (p. 25), but we calculated also the absolute value of the wave-length to a close approximation. Bohr's interpretation of the regular increase in frequency of the spectrum lines observed by Moseley is that the electric charge of the nucleus increases by one electronic unit as we pass from one element to that next higher in the scale of atomic numbers. As we have seen in earlier chapters, this postulate of Bohr's theory is amply supported by independent evidence.

The assumption of electronic orbits, though it thus made possible the calculation of energy levels agreeing approximately with those that are found, has, however, met various vicissitudes. It will nevertheless be of value to review briefly some of the attempts that have been made to account for the details of the spectra in terms of the properties of the electronic orbits.

### 154. *Sommerfeld's Theory of the Origin of the Doublets*<sup>1</sup>

Sommerfeld introduced the suggestion that the electronic motions, instead of being circular, might have radial as well as angular momentum. In accord with the general quantum rules

<sup>1</sup> A. Sommerfeld, *Atombau u. Spektrallinien* (1924).

discussed in the last chapter, and using Newtonian dynamics, he showed that the energy of the orbital motion depends only upon the sum of the number of quanta of angular momentum and of radial momentum. This sum he identifies with the principal quantum number. Since the law of force which governs the electron's motion is the inverse square law, the orbit is an ellipse. The ratio of the minor to the major axis of the ellipse is calculated to be equal to the ratio of the angular to the total quantum number. This accounts for the existence of *K*, *L*, *M* and *N* orbits of the following forms: (Fig. 127)

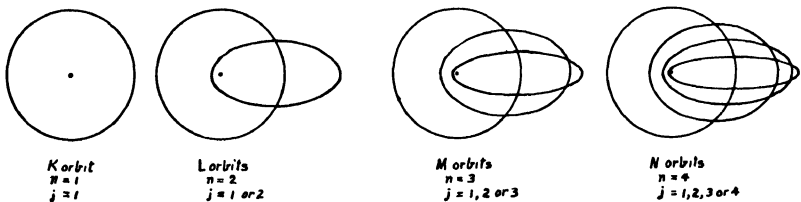

FIG. 127.

On this basis, one identifies the “inner” quantum number of energy level with the angular or azimuthal quantum number of the corresponding orbit.

When calculated according to Newtonian mechanics, Sommerfeld finds for the total energy of an electron revolving about a nucleus in an ellipse, neglecting the screening effect due to other electrons,

$$W = \frac{2\pi^2 e^4 Z^2 m}{n^2 h^2} = Rh \frac{Z^2}{n^2}, \quad (\text{II. 11})$$

where *R* is Rydberg's constant. This is the same as that found in equation (I.09) for circular orbits, and depends only on the total quantum number. When the dynamics of the special relativity theory are employed, however, Sommerfeld finds for the energy

$$W = Rh \left\{ \frac{Z^2}{n^2} + \alpha^2 \frac{Z^4}{n^4} \left( \frac{n}{j} - \frac{3}{4} \right) \right\}, \quad (\text{II. 12})$$

neglecting higher powers of  $\alpha$ , where  $\alpha$  is a small constant having the value

$$\alpha = \frac{2\pi e^2}{hc} = 7.29 \times 10^{-3}. \quad (11.13)$$

The term in  $\alpha^2$  occurs because of the relativity increase in mass due to the high velocity of the electron.

For circular orbits  $n = j$ , and the second term within the brackets becomes  $\frac{1}{4}\alpha^2 \frac{Z^4}{n^4}$ . Neglecting higher powers of  $\alpha$  than the second, this makes  $W$  a parabolic function of  $Z^2$ , instead of a linear function as in Moseley's equation (11.08). It is this term which is used to account for the fact that the line in Fig. 126 which connects the points representing the  $K$  absorption frequencies is not straight but is slightly curved. This prediction of the relativity theory is subject to a quantitative test. In accord with equation (11.12) we may write for the energy of the  $K$  level of an atom the expression,

$$W = Rh \left\{ \frac{(Z - s)^2}{n_K^2} + \frac{1}{4}\alpha^2 \frac{(Z - s)^4}{n_K^4} \right\} = \frac{hc}{\lambda_K}, \quad (11.14)$$

where we have written  $Z-s$  instead of  $Z$ ,  $s$  being the screening constant (cf. p. 340). In the case of calcium, Fricke has found  $\lambda_K = 3.0633\text{\AA}$ . Using the experimental values,  $R = 3.2775 \times 10^{15} \text{ sec}^{-1}$ ,  $Z = 20$ ,  $n_K = 1$  for the  $K$  series and  $\alpha = 7.29 \times 10^{-3}$ , we can solve this expression for  $s$ , obtaining  $s = 2.76$ . For an element of so low an atomic number, the value of the screening constant thus calculated depends only slightly on the value assigned to  $\alpha$ . We may now calculate  $\alpha$  for an element of high atomic number, such as uranium, assuming that this element has the same value of the screening constant as does calcium. Thus, using in the above expression  $s = 2.76$ , and Duane's value  $\lambda_K = .1075\text{\AA}$  for uranium, we obtain  $\alpha = 5.9 \times 10^{03}$ , which is to be compared with the theoretical value  $7.3 \times 10^{-3}$ .

This agreement as to order of magnitude must be considered a strong confirmation of Sommerfeld's theory of the relativity

change of mass of the electron in its orbit. That the agreement is not exact is not surprising, in view of the fact that we have neglected terms in  $a$  of higher power than 2, and also since the electrons in the outer shells of uranium probably affect to some extent the value of the screening constant.

The second term of expression (11.12) takes different values for different values of  $n/j$ . Thus for each value of the principal quantum number  $n$  there are  $n$  slightly different values of the energy of the orbits corresponding to the  $n$  different values that  $j$  may have. Keeping the value of  $n$  constant it will be seen from equation (11.12) that the energy difference between two orbits of angular quantum numbers  $j_1$  and  $j_2$  is,

$$\Delta W = Rh\alpha^2 \frac{(Z-s)^4}{n^3} \left( \frac{1}{j_1} - \frac{1}{j_2} \right), \quad (11.15)$$

if the screening constant has the same value  $s$  in both cases. This means a change of frequency

$$\Delta \nu = \frac{\Delta W}{h} = R\alpha^2 \frac{(Z-s)^4}{n^3} \left( \frac{1}{j_1} - \frac{1}{j_2} \right). \quad (11.16)$$

If we solve equation (11.16) for the screening constant  $s$ , it is found that the experimental value of  $\Delta \nu$  for the  $L_{III}$ - $L_{II}$  doublet, is obtained if  $s$  has a value of about 3.5. In fact Sommerfeld has shown that, if the expression corresponding to (11.16) but retaining the higher powers of  $\alpha$  is used, the appropriate value of  $s$  lies between 3.42 and 3.56 for all the elements for which the doublet has been precisely measured. The fact that the screening constant is thus the same for all elements seems at first sight a strong confirmation of the theory.

If, however, one uses the value of  $s$  required to calculate  $\nu = \frac{W}{h}$  for the  $L_{III}$  orbit according to equation (11.14), we have for the value of  $s$  approximately 18, which leads to a value of  $\Delta \nu$  in equation (11.16) about  $\frac{1}{3}$  that found by experiment. It might be supposed that the value of  $s$  appropriate for equation (11.16) should be smaller than that required in equation (11.14), since the former equation depends chiefly upon the

electron's motion near the perihelion where its velocity is greatest and where the screening effect due to other electrons is least. But this would be difficult to reconcile with the assumption underlying equation (11.15), that the screening constant has the same value for an elliptic orbit with  $j = 1$  as it has for a circular orbit with  $j = 2$ . We are thus unjustified in interpreting the constancy of  $s$  in equation (11.16) as a quantitative support of Sommerfeld's conception of quantized elliptic orbits.

It is nevertheless apparent that the order of magnitude of the frequency difference predicted by this theory is in agreement with that of the observed regular doublets. If the screening constant is neglected altogether, we have from (11.16),

$$\begin{aligned} \Delta\lambda &= -\frac{c}{\nu^2}\Delta\nu = \frac{c}{R^2\frac{Z^4}{n^4}}R\alpha^2\frac{Z^4}{n^3}\left(\frac{1}{j_1} - \frac{1}{j_2}\right) \\ &= \frac{cn\alpha^2}{R}\left(\frac{1}{j_1} - \frac{1}{j_2}\right), \end{aligned} \quad (11.17)$$

neglecting higher powers of  $\alpha$ . Thus to a first approximation the wave-length difference of the "relativity" doublet is independent of the atomic number, which is the distinguishing feature of the "regular" doublet. At least the major characteristics of this doublet are thus adequately accounted for by Sommerfeld's theory.

If in (11.17) we substitute

$$\alpha^2 = 4\pi^2e^4/h^2c^2$$

and

$$R = 2\pi^2me^4/h^3,$$

we have at once

$$\begin{aligned} \Delta\lambda &= \frac{h}{mc} \times 2n\left(\frac{1}{j_1} - \frac{1}{j_2}\right) \\ &= \gamma \times 2n\left(\frac{1}{j_1} - \frac{1}{j_2}\right), \end{aligned} \quad (11.18)$$

where

$$\gamma = h/mc = .0243A.$$

This is the same quantity  $\gamma$  which entered so prominently in our discussion of the change of wave-length of scattered X-rays. It is interesting to note that the wave-length separation of the limiting doublet of the Balmer series of hydrogen is

$$\Delta\lambda_H = 2\gamma = .0485A, \quad (11.19)$$

which is precisely the maximum wave-length shift that can occur due to scattering.

Several alternative suggestions have recently been made regarding the origin of the regular doublet. One of these interprets it as due to the difference in energy of the orbit at different orientations relative to the magnetic axis of the remainder of the atom. Another ascribes the doublet to a magnetic field arising from a rotation of the electron itself. Both hypotheses may be shown to lead to expressions for the magnitude of the doublet of the same type as that given by Sommerfeld's relativity elliptic orbit theory.

*The Irregular Doublet.* To account for the regular doublets, we imagined that the screening constant of two orbits was the same, but that only the angular quantum number was altered. Let us now suppose that the angular momentum remains constant, but that the screening constant  $s$  differs for the two orbits. If we neglect the small terms in  $\alpha$ , the frequency associated with an orbit of energy  $W$  is, according to equation (11.12),

$$\nu = \frac{W}{h} = R \frac{(Z - s)^2}{n^2}$$

or

$$\sqrt{\frac{\nu}{R}} = \frac{Z - s}{n}.$$

If for two orbits otherwise alike  $s$  has different values, we thus have

$$\Delta\sqrt{\frac{\nu}{R}} = \frac{1}{n}(s_2 - s_1). \quad (11.20)$$

This corresponds exactly to the "irregular" doublets, as indeed Hertz noticed in his original investigation of these doublets.

For this reason the irregular doublets are frequently called "screening" doublets.

The  $L_{II}-L_I$  doublet is one of this type. Thus for three typical elements we have the following values,

TABLE XI-5

Element	$\frac{\Delta\lambda}{L_2 - L_3}$	$\frac{\Delta\sqrt{\nu/R}}{L_3 - L_2}$	$s_2 - s_1$
51 Sb	.1983A	.66	1.32
74 W	.0486	.68	1.36
90 Th	.0242	.76	1.52

Though  $\Delta\lambda$  varies widely,  $\Delta\sqrt{\nu/R}$  is almost constant. The increase in  $s_2 - s_1$  for the heavy elements is due at least in part to our neglect of the terms in  $\alpha^2$ .

If the doublet  $L_{II}-L_I$  is a screening doublet, we must assume that the ellipticity is the same for both orbits. The suggestion has been made that the difference  $s_2 - s_1$  in the screening constant may be due to a difference in the orientation of the plane of the two orbits, which might well give rise to slightly different forces on the electrons. Experimentally it is found that there are only  $2n - 1$  levels of principle quantum number  $n$ . It would thus appear that the circular orbit assumes only one value of the screening constant, whereas each elliptic orbit may have 2. Thus we account for, or rather describe, the fact that there are 1 *K* orbit, 3 *L* orbits, 5 *M* orbits, etc.

### 155. *Difficulties with Sommerfeld's Theory*

In spite of these successes of Sommerfeld's explanation of the origin of the regular and irregular doublets, there seem to be insuperable objections to accepting this interpretation. Of these difficulties we may mention the following:

1. It is very difficult to explain why an elliptic orbit in an atom containing many electrons should differ from a circular or-

bit of the same principle quantum number only by the relativity correction. For the forces on an electron in the two orbits, due to the neighboring electrons, will differ, and this must give rise to different screening constants. It would thus seem impossible to vary the azimuthal quantum number without altering the screening constant, as Sommerfeld assumes to explain the regular doublets.

2. The selection rules governing the transfers from one level to another do not agree with those found to hold for optical spectra, if we take Sommerfeld's interpretation of the significance of the quantum numbers  $k$  and  $j$ . Thus in optical spectra (both band and line spectra) there is very good evidence that transfers occur only when the azimuthal quantum number changes by  $\pm 1$ . This corresponds precisely with the transfers shown in Fig. 126 if  $k$  is identified with the azimuthal quantum number. In order to account for the regular doublets as relativity doublets, however, it is necessary to suppose that  $j$  instead of  $k$  represents the azimuthal quantum number.

3. Recent experiments by Millikan and Bowen<sup>1</sup> have demonstrated the fact that the regular doublets of X-ray spectra have the same origin as certain types of optical doublets (such as the  $D$  lines of sodium), which are ordinarily attributed to differences in the inner rather than the azimuthal quantum number. Thus, for example, the  $2p_1$  and the  $2p_2$  levels, from which the electrons start that give rise to the sodium  $D$  lines, are supposed to have the same *azimuthal* quantum number,  $K = 2$ . This is in accord with the general evidence that the *azimuthal* quantum number is

$$\begin{aligned} k &= 1 \text{ for sharp series terms} \\ k &= 2 \text{ for principal series terms} \\ k &= 3 \text{ for diffuse series terms} \\ k &= 4 \text{ for Bergmann series terms.} \end{aligned}$$

Thus, unless there is some fundamental error in the assign-

<sup>1</sup> R. A. Millikan and I. S. Bowen, *Phys. Rev.* **23**, 1; 244, pp. 1, 209; 223 (1924); **25**, pp. 295, 591; **26**, pp. 150, 310 (1925); **27**, 144 (1926).

ment of the quantum numbers to optical spectra, we must conclude that there is no physical significance in the numerical agreement with experiment of Sommerfeld's relativity doublets.

This does not mean that the relativity effect is absent. Its presence we have seen is confirmed by the curvature of the line connecting the  $K$  series limits in the Moseley diagram. But in the doublets the effect of such relativity differences must be masked by the effects of interactions between the different electrons in the atoms. We can only conclude that no adequate explanation of the origin of the X-ray doublets has as yet been presented.

### 156. *Electron Distributions Determined by X-ray Spectra*

We have seen that the number of electrons in an atom is equal to the atomic number. This means that the numbers of electrons in the noble gases, helium, neon, argon, krypton, xenon and radon are respectively, 2,  $2 + 8$ ,  $2 + 8 + 8$ ,  $2 + 8 + 18 + 8$ ,  $2 + 8 + 18 + 18 + 8$  and  $2 + 8 + 18 + 32 + 18 + 8$ . From a consideration of the periodic table it has long been recognized that a group of 8 electrons at the surface of an atom must correspond to a very stable or inert atom. From our study of X-ray absorption, also, we have found support for the assignment of 2 electrons to the  $K$  shell and 8 electrons to the  $L$  shell. It is thus natural to suppose that these numbers represent the number of electrons in the different shells in the atom. For radon, as an example, this would mean there are 2  $K$  electrons, 8  $L$  electrons, 18  $M$  electrons, 32  $N$  electrons, 18  $O$  electrons and 8  $P$  electrons. A discussion of the evidence for such a grouping has been presented by Bohr and Coster.<sup>1</sup>

Stoner<sup>2</sup> has called attention to the fact that the number of electrons in each of the completed electron shells as thus assigned is just twice the sum of the inner quantum numbers  $j$

<sup>1</sup> N. Bohr and D. Coster, *Zeits. f. Physik*, **12**, 342 (1922); N. Bohr, "The Theory of Spectra and Atomic Constitution" (Cambridge, 1922); also, *Supplement to Nature*, July 7, 1923.

<sup>2</sup> E. C. Stoner, *Phil. Mag.* **48**, 719 (1924).

for this shell. Thus for the completed  $M$  shell we have the quantum numbers,

$$\begin{array}{cccccc} n & 3 & 3 & 3 & 3 & 3 \\ k & 1 & 2 & 2 & 3 & 3 \\ j & 1 + 1 + 2 + 2 + 3 & = 9 \times 2 = 18 = 2\Sigma j_m, \end{array}$$

which is the number 18 suggested for the electrons in the  $M$  shell.

Evidence from a study of the multiplicity of the lines observed in the Zeeman effect with optical spectra indicates, however, that in a weak magnetic field the number of possible states of the atom is equal to twice this inner quantum number. These  $2j$  states are equally probable and always possible, but it is only in the presence of an external magnetic field that they differ in energy in such a manner that their separate existence becomes evident. The inner quantum number is usually taken to be the azimuthal quantum number of the atom as a whole (that of the individual electron orbit being  $k$ ) and hence as a measure of the atom's magnetic moment. The suggestion has been made by Sommerfeld<sup>1</sup> that the angular momentum about any axis such as that supplied by the direction of an external magnetic field should be an integral multiple of  $h/2\pi$  (space quantization). That is, if the atom's total angular momentum is  $j\hbar/2\rho$ , the possible orientations of the atom would be such that the angular momentum about the direction of the magnetic field would be  $\pm 1 \cdot h/2\pi$ ,  $\pm 2 \cdot h/2\pi$ , . . .  $\pm j\hbar/2\pi$ , or  $2j$  orientations altogether (the omission of the orientation  $0 \cdot h/2\pi$  has no obvious theoretical justification).

Of course these optical spectra come from electrons in incomplete shells. But the inference is strongly suggested that an energy level becomes complete when there is an electron in every possible orbit consistent with this idea of space quantization. This suggestion results at once in assigning  $2\Sigma j_K = 2$  electrons to the  $K$  level,  $2\Sigma j_L = 8$  to the  $L$  level, etc. But it goes further, assigning also the numbers of electrons to each of

<sup>1</sup> A. Sommerfeld, "Atomic Structure and Spectral Lines," p. 242.

TABLE XI-6  
NUMBER OF ELECTRONS IN VARIOUS ORBITS (STONER)

Element	K		L	M	N	O	P
	n	1	2	3	4	5	6
	k	1	1 2	1 2 3	1 2 3 4	1 2 3	1 2
	j	1	1 1 2	1 1 2 2 3	1 1 2 2 3 3 4	1 1 2 2 3	1 1 2
1 H	1						
2 He	2						
3 Li	2	1					
4 Be	2	2					
5 B	2	2 1					
6 C	2	2 2					
---	---	---					
10 Ne	2	2 2 4					
11 Na	2	2 2 4	1				
---	---	---	---				
18 A	2	2 2 4	2 2 4				
19 K	2	2 2 4	2 2 4	1			
20 Ca	2	2 2 4	2 2 4	2			
21 Sc	2	2 2 4	2 2 4 1	2			
---	---	---	---	---			
29 Cu	2	2 2 4	2 2 4 4 6	1			
---	---	---	---	---			
36 Kr	2	2 2 4	2 2 4 4 6	2 2 4			
37 Rb	2	2 2 4	2 2 4 4 6	2 2 4	1		
38 Sr	2	2 2 4	2 2 4 4 6	2 2 4	2		
39 Y	2	2 2 4	2 2 4 4 6	2 2 4 1	2		
---	---	---	---	---	---		
47 Ag	2	2 2 4	2 2 4 4 6	2 2 4 4 6	1		
---	---	---	---	---	---		
54 X	2	2 2 4	2 2 4 4 6	2 2 4 4 6	2 2 4		
55 Cs	2	2 2 4	2 2 4 4 6	2 2 4 4 6	2 2 4	1	
56 Ba	2	2 2 4	2 2 4 4 6	2 2 4 4 6	2 2 4	2	
57 La	2	2 2 4	2 2 4 4 6	2 2 4 4 6 1	2 2 4	2	
---	---	---	---	Rare Earths	---	---	---
71 Lu	2	2 2 4	2 2 4 4 6	2 2 4 4 6 6 8	2 2 4 1	2	
79 Au	2	2 2 4	2 2 4 4 6	2 2 4 4 6 6 8	2 2 4 4 6	1	
---	---	---	---	---	---	---	---
86 Rn	2	2 2 4	2 2 4 4 6	2 2 4 4 6 6 8	2 2 4 4 6	2 2 4	

the various sub-levels as equal to  $2j$ , as indicated in Table XI-6. It is obvious that in the outermost orbits these electrons have been distributed in such a way as to correspond to the chemical properties of the atoms.

Confirmatory evidence has been found for certain parts of this suggested distribution. Thus the observed fact<sup>1</sup> that the ratio of intensity of the  $K\alpha_1$  line to the  $K\alpha_2$  line is 2 : 1 is in accord with Stoner's assignment of twice as many electrons to to the  $2_{22}$  orbits as to the  $2_{21}$  orbits. Similarly, for the other lines whose intensities afford a test of the electron distributions, Stoner shows that the agreement is satisfactory.

According to the theory of the absorption of X-rays developed in Chapter VI, it follows that the absorption due to any electron group should be proportional to  $N_K/\lambda_K^2$ , where  $N_K$  is the number of electrons of this type per atom, and  $\lambda_K$  is the critical absorption wave-length for these electrons. Dauvillier<sup>2</sup> finds for the relative absorption due to the  $L_{III} : L_{II} : L_I$  electron groups of gold the values 62:41 : 35. Considering the different critical wave-lengths of the different levels, these values lead to a ratio of electron numbers, 4.04 : 2 : 1.56, which is probably as near to the ratio 4 : 2 : 2 as the accuracy of the experiments would warrant.

In like manner the experiments of Robinson in studying the various photoelectron groups with the magnetic spectrograph, as discussed in Chapter VIII, give intensities of the different groups in reasonably good agreement with the electron numbers assigned in Table XI-6.

On the whole it may be said that the evidence at present available offers some support to this electron distribution, and that no evidence has as yet appeared which would seem to require its modification.

It would not be fair to leave the impression that this electron distribution has been assigned as a result of studies of X-ray spectra alone. Through the work of Lewis, Langmuir and others, considerations of the chemical properties of the atoms

<sup>1</sup> Cf. e.g., Siegbahn, "The Spectroscopy of X-Rays," p. 97 (1925).

<sup>2</sup> A. Dauvillier, *Comptes Rendus* 178, 476 (1924).

have played an important part in determining the number of electrons in the various shells, whereas Bohr, Stoner, Sommerfeld and others have brought to bear physical evidence from a wide variety of sources, such as optical spectra and magnetic properties.

Regarding the dimensions of the electron orbits it is difficult to make definite statements, because the dynamical problem of the interpenetrating orbits is exceedingly complicated. Hartree<sup>1</sup> has made approximate calculations of the electron distances from the center, however, from a consideration of the known energies of the various orbits. In general the distances of the electrons from the atomic centers as thus calculated are of the same order, but somewhat smaller than those estimated in Chapter V from the intensity of the reflection of X-rays from crystals. It would be premature to discuss whether this difference is due to inaccurate calculations from the spectroscopic data, or to a failure in the laws of diffraction as applied to the intensity of X-ray reflection from crystals.

<sup>1</sup> Hartree, D. R., *Camb. Phil. Soc. Proc.* Vol. 22, pp. 464-474, 1924.

## CHAPTER XII

### QUANTUM THEORY OF X-RAY PRODUCTION AND ABSORPTION

#### 157. *Relation between the Emission and Absorption of X-rays*

The X-rays which are produced when cathode rays strike the target of an X-ray tube presumably occur when a cathode electron is deflected by an atomic nucleus. This cathode electron cannot remain in an inner orbit of a normal atom since the possible inner orbits are already occupied. It must either escape with a part of its initial energy or it must eject one of the electrons originally a part of the atom. If the emergent electron has a final velocity zero, all the energy of the incident electron reappears in the quantum of radiation that is emitted, whence according to Bohr's frequency condition,

$$\frac{1}{2}mv^2 = h\nu_{\max}, \quad (12.01)$$

a formula which expresses the maximum frequency that is experimentally observed. If the emergent electron carries with it an appreciable part of the incident electron's kinetic energy, the energy and hence the frequency of the resulting quantum will be reduced. Thus it is possible to account for a continuous spectrum with a definite upper limit to the frequency.

According to Kirchhoff's law, when matter and radiation are in equilibrium with each other, at any temperature, the matter must emit as much radiation of each frequency as it absorbs. That is, there must be some mechanism capable of emitting each frequency that is absorbed. It follows that there must be an emission band in every region of the spectrum in which an absorption band is found to occur. Kirchhoff's law is not concerned with the type of mechanism whereby the emis-

sion and absorption take place; but if we think of the absorption of X-rays as resulting in the ejection of a photoelectron, we see that the corresponding emission process is the binding of a rapidly moving electron by an ionized atom with the resulting emission of a quantum of radiation. The application of such considerations to the problem of the absorption of X-rays was first made by L. de Broglie.<sup>1</sup>

It is true that in our experiments, though absorption bands are found to appear in the X-ray region, no emission bands have been observed. This is however in no way contradictory to Kirchhoff's law, since the target of the X-ray tube is not in thermal equilibrium with the radiation it is emitting. The temperature would have to be of the order of  $10^8$  degrees within the X-ray tube for equilibrium to occur between the emitted and the absorbed X-rays. At such a temperature an appreciable fraction of the atoms would have their inner orbits ionized, and radiation due to the binding of high speed electrons in the inner orbits would give rise to emission bands in the same region of the spectrum as the absorption bands. At ordinary temperatures, however, there is no appreciable number of atoms whose inner orbits are ionized, so the reverse process does not occur.

### 158. *L. de Broglie's Theory of X-ray Absorption*

In applying Kirchhoff's law to the absorption of X-rays, de Broglie assumes that Wien's energy distribution law holds for black body radiation for such high frequencies as X-rays, and he makes use of Bohr's frequency condition. Following a thermodynamical argument he thus finds that the true atomic absorption coefficient should be

$$\tau_a = \frac{1}{8\pi k C T} \sum \eta_p A_{ip}^n W_p \cdot \lambda^3. \quad (12.02)$$

Here  $k$  is Boltzmann's constant,  $T$  the absolute temperature,

<sup>1</sup> L. de Broglie, Journ. de Phys. 3, 33 (1922).

$A_{ip}^n$  the probability that an atom ionized by the loss of an electron from the  $p$ th shell will return to its normal condition in unit time,  $W_p$  is the energy required to remove an electron from the  $p$ th orbit, and  $n_p$  is an undetermined constant of the order of unity.

In view of the soundness of his assumptions, the theoretical basis for the  $\lambda^3$  law of absorption for this region of the spectrum seems very strong. While some experiments have seemed to throw doubt on the exact validity of the third power relation, those in the neighborhood of the critical wave-lengths are performed under adverse conditions, and those at short wave-lengths are difficult to interpret because of the unknown value of the scattering. When one considers the various possible sources of error in determining the experimental values of  $\tau_a$ , it is doubtful whether the experiments have established any real departure from the cube law in the region of ordinary X-rays.

De Broglie extends this result by making some rather arbitrary assumptions, which seem to be verified by their consequences, obtaining finally,

$$\tau_a = \frac{\pi e^2}{mc^2} \lambda^3 \left\{ \left( \eta_K \frac{N_K}{\lambda_K^2} \right)_{\lambda < \lambda_K} + \left( \eta_L \frac{N_L}{\lambda_L^2} \right)_{\lambda < \lambda_L} + \dots \right\}, \quad (12.03)$$

where  $N_K$  is the number of electrons in the  $K$  orbits, and  $\lambda_K$  is the critical  $K$  absorption wave-length. Except for a factor  $\eta/2$ , or approximately  $\frac{1}{2}$ , this is precisely the same expression as equation (6.30), which was derived from classical considerations. In view of the approximate Bohr-Moseley relation that  $1/\lambda_K = (2\pi^2 e^4 m / n_K^2 c h^3) Z^2$ , where  $n_K$  is the quantum number of the  $K$  orbits, this result is also approximately equivalent to Owen's empirical law (eq. 6.06).

$$\tau_a = KZ^4 \lambda^3. \quad (12.04)$$

The value of the constant  $K$  for the absorption due to the  $K$  electrons is, on this theory,

$$K_K = \frac{8\pi^5 m e^{10}}{c^4 h^6} = .021. \quad (12.05)$$

Within the errors of experiment and computation, this is equal to the experimental value  $K_K = .019$ , as given in equation (6.07).

### 159. *Kramers' Theory of Emission and Absorption*<sup>1</sup>

Kramers has also approached the problem of absorption through its relation to emission, but has developed the theory in a widely different and somewhat less arbitrary manner. The atomic absorption coefficient  $\tau_a$  has been defined as the fraction of the energy of a beam of unit cross section which is absorbed by an atom. We may accordingly use  $\tau_a$  to represent the area of cross section of a sphere associated with each atom, such that the radiation which traverses this sphere is absorbed while that which does not strike the sphere passes on unaffected.  $\tau_a$  is thus the effective absorptional cross section of the atom. On the other hand, if an electron approaches an ionized atom with a certain velocity, the probability that it will be bound by the atom with the resultant emission of a quantum may be described in terms of another effective cross section of the atom,  $\beta$ , such that the free electron will be bound by the atom if, and only if, it strikes within this area. The condition for equilibrium used by Kramers is that the probability that an atom will absorb radiation with the resultant expulsion of a photoelectron from any energy level with a velocity  $v$  is equal to the probability that a free electron with velocity  $v$  will be bound by an atom which lacks an electron in this level with the resultant emission of a quantum of radiation.

By making use of Boltzmann's relation for the relative probability of states having different energies, Bohr's conclusion that the a priori probability for an electron to be bound to an atom in an orbit of quantum number  $n$  is  $ah^3$ , where  $h$  is Planck's constant and  $a$  is the "statistical weight"  $n(n+1)$  of the electron's orbit, and introducing Wien's form of the law of heat radiation as appropriate for the high frequency end of the

<sup>1</sup> H. A. Kramers, *Phil. Mag.* 46, 836 (1923).

spectrum, Kramers shows that equilibrium will occur if the two effective radii bear the following relation to each other:

$$\tau_a = \frac{m^2 v^2 c^2}{2 a h^2 \nu^2} \beta. \quad (12.06)$$

The importance of this relation lies in the fact that if it is found possible by any means to calculate the emission probability,  $\beta$ , we can immediately calculate the absorption coefficient  $\tau_a$ .

### 160. *The Intensity of the Radiation*

In order to estimate the intensity of the X-rays emitted, Kramers calculates according to the classical electrodynamics the radiation produced at an encounter between an electron and

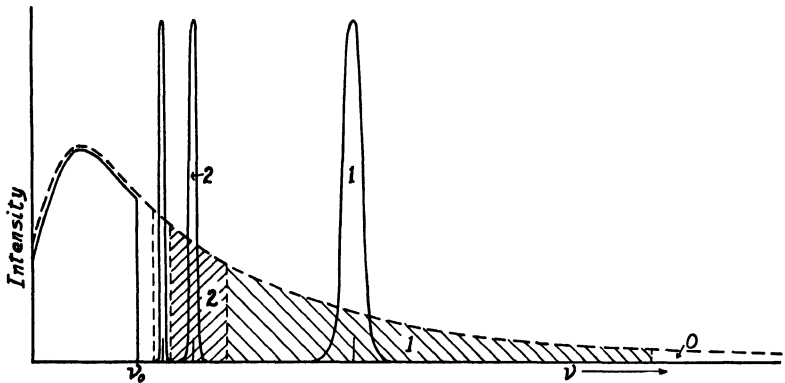

FIG. 128.

an atomic nucleus. The broken line of Fig. 128 shows the energy distribution for different frequencies resulting from this calculation. Radiation is predicted for all frequencies from zero to infinity.

Experiments show, however, in accord with the quantum theory, that when electrons strike a neutral atom the spectrum stops sharply at the frequency  $\nu_0 = \frac{1}{2}mv^2/h$ . In general accord with Bohr's correspondence principle, Kramers therefore assumes that when the electrons strike a neutral atom the energy distribution for frequencies less than  $\nu_0$  is approximately

the same as that calculated on the classical theory for an electron approaching a nucleus, but that for higher frequencies no radiation is produced. Thus in Fig. 128 the predicted continuous radiation is represented by the solid line to the left of  $\nu_0$ .

When the electron strikes a bare atomic nucleus, the quantum theory predicts, however, that the electron may be bound by the atom in some one of its possible electron orbits. If the electrons approach the atomic nucleus with a definite speed, such captures must result in definite spectral lines of frequency higher than  $\nu_0$ , since the energy lost is greater than the original kinetic energy of the electrons. Thus there should appear the spectral lines 1, 2, . . . , due to capture of the electrons in orbits of quantum number 1, 2, . . . . Such lines of frequency greater than  $\nu_0$  are never observed in the radiation from an X-ray tube because the relative number of ionized atoms is at any instant small. But it is the production of such lines that is the reverse process of photoelectric absorption.

In order to estimate the intensity of these lines, Kramers assumes that "a certain frequency interval in the radiation emitted on the classical theory corresponds with a process by which the electron is bound in a certain stationary state." He takes this frequency interval to be that corresponding to the range of quantum numbers from  $n - \frac{1}{2}$  to  $n + \frac{1}{2}$ . There is thus a finite probability, corresponding to the shaded areas 1, 2, . . . of Fig. 128, that when an electron moving with a velocity  $v$  passes by an atomic nucleus (or an appropriately ionized atom) it will be bound to the nucleus in an orbit of quantum number  $n$ . This probability, represented by the effective capturing cross section of the nucleus  $\beta$ , Kramers calculates to be approximately

$$\beta = \frac{128\pi^4}{3\sqrt{3}} \frac{Z^4 e^{10}}{mc^3 h^4 v^2 n^3 \nu}, \quad (12.07)$$

where  $Z$  is the atomic number of the nucleus and  $\nu$  is the frequency of the emitted quantum of radiation. .

In order to calculate the intensity of the radiation emitted from an X-ray tube, Kramers takes account of the decrease in

velocity of the electrons traversing the metal by applying the Thomson-Whiddington law, using Bohr's theoretical value of the constant. For the energy between frequencies  $\nu$  and  $\nu + d\nu$  radiated per electron impact he thus finds,

$$I_\nu d\nu = \frac{8\pi}{3\sqrt{3}l} \frac{e^2 h}{mc^3} Z(\nu_0 - \nu) d\nu, \quad (12.08)$$

approximately, where  $l$  is a numerical factor of the order of magnitude of 6. This result is in good accord with Kulenkampff's empirical formula <sup>1</sup>

$$I_\nu = CZ(\nu_0 - \nu) + BZ^2, \quad (12.09)$$

in which the first term is ordinarily much more important than the second.

A quantitative test of the theory is afforded by the calculation of the efficiency of production of X-rays. The formula obtained is,

$$\begin{aligned} \text{Eff.} &= \frac{2\pi}{3\sqrt{3}l} \frac{e^2 v^2}{ch^3} Z \\ &= 2.34 \times 10^{-4} Z \left(\frac{v}{c}\right)^2. \end{aligned} \quad (12.10)$$

Equation (12.10) differs from the efficiency calculated in equation (2.14) by an extension of the Stokes pulse theory only by a factor of

$$\frac{\sqrt{3\pi}}{4l} Z,$$

but has the important advantage that the efficiency is here found to be proportional to  $Z$ , in accord with experiment. Recalling that the atomic weight is equal to about twice the atomic number, Beatty's experimental formula (2.15) for the efficiency may be written,

$$\text{Eff.} = 5 \times 10^{-4} Z \left(\frac{v}{c}\right)^2,$$

which differs from the theoretical relation by a factor of about

<sup>1</sup> H. Kulenkampff, *Ann. d. Phys.* **69**, 548 (1922)

2. In view of the many approximations that are made in Kramers' theory, as well as the very considerable probable error of the experimental coefficient, this agreement is on the whole satisfactory.

### 161. *The Absorption Coefficient*

The value of  $\beta$  given in equation (12.07) represents the effective area of a bare atomic nucleus for capturing electrons. Assuming that when applied to capturing an electron in an orbit of quantum number  $n$  this is the same as the effective area of an ionized atom whose  $n$  orbit lacks an electron, we can at once substitute this value of  $\beta$  in equation (12.06) and calculate the contribution of this  $n$  orbit to the atomic absorption coefficient. The result is that the absorption due to an electron in an  $n$  quantum orbit is

$$\tau_n = \frac{64\pi^4}{3\sqrt{3}} \frac{e^{10}m}{c^4 h^6} \frac{Z^4 \lambda^3}{a_n n^3}. \quad (12.11)$$

If we take "the statistical weight" of the atom in its  $n$  quantum state, to be  $a = n(n + 1)$ , the absorption due to the  $2K$  electrons, thus becomes,

$$\left. \begin{aligned} \tau_K &= \frac{64\pi^4}{3\sqrt{3}} \frac{e^{10}m}{c^4 h^2} \cdot \frac{2}{2} Z^4 \lambda^3 \\ &= .0104 Z^4 \lambda^3. \end{aligned} \right\} \quad (12.12)$$

Here again the experiments (eq. (6.07)) differ from the theoretical result by a factor of about 2, showing that

$$\tau_K = .019 Z^4 \lambda^3.$$

If we assume as usual that there are 8  $L$  electrons ( $n = 2$ ), 18  $M$  electrons ( $n = 3$ ), etc., the absorption by the whole atom is thus calculated to be,

$$\tau_a = \tau_K (1 + \frac{1}{8} + \frac{1}{8} + \dots). \quad (12.13)$$

It will be seen that this method of calculation gives directly an atomic absorption proportional to  $Z^4$ , in exact agreement

with Owen's law. Previous theories that we have examined lead directly to an absorption proportional to  $1/\lambda_K^2$ , which is only approximately proportional to  $Z^4$  through the Bohr-Moseley relation. This difference between the theories, however, appears to be only superficial, since the  $Z^4$  comes into the present expression by neglecting the effect of the electrons surrounding the nucleus, in which case the proportionality between  $Z^4$  and  $\frac{1}{\lambda_K^2}$  becomes exact. If the effect of these electrons is taken into account, the absorption should doubtless be given more accurately by substituting for  $Z^4$  its approximate equivalent

$$\left\{ \frac{n_K^2 c h^3}{2\pi^2 e^4 m \lambda_K} \right\}^2,$$

in which case the absorption coefficient due to the  $K$  electrons becomes,

$$\tau_K = \frac{16}{3\sqrt{3}(n_K + 1)} \frac{e^2}{mc^2} \lambda^3 \frac{N_K}{\lambda_K^2}. \quad (12.14)$$

Corresponding to this expression, de Broglie's theory gives eq. (12.03)

$$\tau_K = \pi \frac{e^2}{mc^2} \lambda^3 \frac{N_K}{\lambda_K^2},$$

while from the classical electron theory we calculated (6.30)

$$\tau_K = 2\pi \frac{e^2}{mc^2} \lambda^3 \frac{N_K}{\lambda_K^2}.$$

The most significant difference between equation (12.14) and the other two equations is in the factor  $1/(n_K + 1)$ , which has the effect of reducing the relative absorption by the electrons in higher quantum orbits. Comparison with the experimental values collected in Chapter VI indicates that this factor makes Kramers' formula agree less satisfactorily with the experiments than if it were omitted. De Broglie's absorption formula undoubtedly fits the experimental data better than the others that have been proposed. Nevertheless in calculating the

numerical coefficient of the formula the method followed by Kramers seems fundamentally to be the more sound. It is probable that the lack of complete agreement between his formula and the experiments is due to the various approximations and arbitrary minor assumptions that he has found it necessary to introduce.

### 162. *Emission of X-rays as Directed Quanta*

We have seen in Chapter II that if we adopt Stokes' pulse hypothesis of the nature of the X-rays we arrive at an explanation of both the polarization of the X-rays coming from the target of an X-ray tube and also of the fact that the X-rays emitted in the general direction of the cathode ray stream are of higher frequency and more intense than those emitted backwards. Though Kramers' theory does not discuss these problems specifically, his calculation of the radiation emitted as an electron passes an atomic nucleus gives a result closely analogous to a Stokes radiation pulse, and a complete classical treatment of this case would undoubtedly likewise predict polarization and asymmetry effects. From the manner in which he has applied the correspondence principle, however, it is not at all obvious that there should be any difference in frequency between the rays emitted forward and backward. For though the classical theory would predict relatively more energy in the higher frequencies for the rays emitted in the forward than for those in the backward direction, Kramers has supposed that in both directions the continuous spectrum is cut off sharply at the frequency limit given by  $h\nu = eV$ .

Definite predictions of the degree of asymmetry in the frequency of the radiation in different directions and of the amount of polarization of the primary X-rays are made by a suggestive theory of F. W. Bubb.<sup>1</sup> This theory assumes that the X-rays are emitted as directed quanta, and applies to them the principles of the conservation of energy and momentum. In common with de Broglie and Kramers, Bubb thinks of the

<sup>1</sup> F. W. Bubb, *Phys. Rev.* **24**, 177 (1924).



where  $\beta_i c$  is the initial velocity. After the collision the quantum proceeds in some direction  $\overline{OP}$  with a momentum

$$\overline{OA} = h\nu/c,$$

and the momentum of the atom, being due wholly to the impulse imparted at the origin of the quantum, lies in a plane  $\Omega$  drawn perpendicular to  $OP$ . It is represented in the figure by

$$\overline{BC} = MV,$$

$M$  being the mass and  $V$  the final velocity of the atom. Then for the momentum to be conserved, the momentum of the electron after the collision must be represented by

$$\overline{AB} = m\beta_f c / \sqrt{1 - \beta_f^2}.$$

We then have the vector equation

$$\overline{OC} = \overline{OA} + \overline{AB} + \overline{BC}. \quad (12.15)$$

The magnitude of the vector  $\overline{OC}$  is set by the initial conditions, and if we assign a definite value to the frequency  $\nu$  of the emitted radiation, the magnitude of the vector  $\overline{OA}$  is determined. The length of the vector  $\overline{AB}$  may then be calculated from the principle of energy conservation. From this principle we have directly,

$$mc^2 \left( \frac{1}{\sqrt{1 - \beta_f^2}} - 1 \right) = h\nu + mc^2 \left( \frac{1}{\sqrt{1 - \beta_i^2}} - 1 \right) + \frac{1}{2} MV^2. \quad (12.16)$$

Since the final momentum of the atom is of the same order of magnitude as the momentum of the electron, and since its mass is of the order of  $10^5$  times as great, its kinetic energy  $\frac{1}{2} MV^2$  will be negligible compared with that of the electron. Dropping this term, equation (12.16) may be written,

$$\frac{mc^2}{\sqrt{1 - \beta_f^2}} = h\nu + \frac{mc^2}{\sqrt{1 - \beta_i^2}}.$$

Solving for the final momentum of the electron, we have

$$\overline{AB} = \frac{m\beta_j c}{\sqrt{1 - \beta_j^2}} = \sqrt{\frac{m^2\beta_i^2 c^2}{\sqrt{1 - \beta_i^2}} - \frac{2mh\nu}{\sqrt{1 - \beta_i^2}} + \frac{h^2\nu^2}{c^2}}. \quad (12.17)$$

Since  $A$  is an assigned point,  $\overline{AB}$  a definite length, and  $\Omega$  a fixed plane, the locus of  $B$  is a circle on the plane  $\Omega$  with its center at  $P$ . The radius of this circle may be shown to be given by,

$$\overline{PB}^2 = \frac{m^2\beta_i^2 c^2}{\sqrt{1 - \beta_i^2}} \sin^2 \phi - \frac{2mh\nu}{\sqrt{1 - \beta_i^2}} (1 - \beta \cos \phi). \quad (12.18)$$

### 163. Frequency of the Emitted Quanta

It is apparent from equation (12.16) that the emitted quantum has its greatest energy when the final energy of the electron is zero. In this case,

$$mc^2 \left( \frac{1}{\sqrt{1 - \beta_i^2}} - 1 \right) = h\nu, \quad (12.19)$$

which expresses the law of Duane and Hunt, and is the inverse of Einstein's photoelectric equation. It will be seen from Fig. 129 that in this case  $AB = 0$ , which means that the point  $A$  coincides with  $P$  and the line  $BC$  with  $PC$ . Since  $PC$  is drawn perpendicular to  $OA$ , this means that

$$\phi = \cos^{-1} \frac{OA}{OC} = \cos^{-1} \frac{h\nu/c}{m\beta_i c / \sqrt{1 - \beta_i^2}},$$

or

$$\cos \phi = (1 - \sqrt{1 - \beta_i^2}) / \beta_i. \quad (12.20)$$

This means that there is only one angle at which the rays of the limiting frequency can be emitted, and that this angle is somewhat less than  $90^\circ$  with the cathode ray beam.

The maximum frequency at any other angle with the cathode ray beam will be emitted when the radius  $PB$  is equal to

zero. On solving equation (12.18) for the frequency we then obtain

$$\nu_0 = \frac{m\beta_i^2 c^2}{2h\sqrt{1-\beta_i^2}} \frac{\sin^2 \phi}{1-\beta_i \cos \phi}. \quad (12.21)$$

In Fig. 130 is shown a polar diagram of this equation for various different values of  $\beta$ . From this figure it is clear that the average frequency in the forward direction should be greater than that at large angles with the cathode rays.

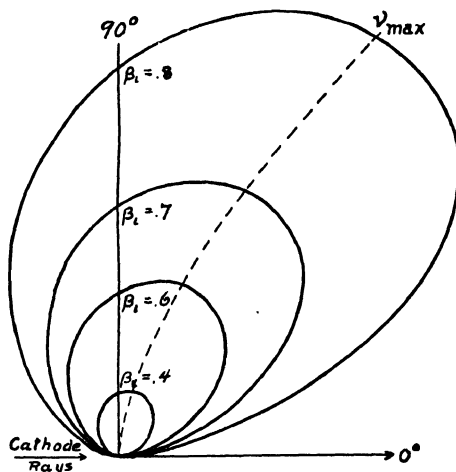

FIG. 130.

Wagner's experimental spectra (Fig. 26), show, on the other hand, the same limiting frequency at large and small angles. It does not seem impossible that this may be due to the fact that many of the cathode electrons have their paths bent before they have lost any appreciable amount of energy. Bubb's theory of course applies directly only to the passage of electrons through very thin targets, and as yet no experimental data with thin targets are available to make a satisfactory test.

164. *Polarization*

From the standpoint of radiation quanta, Bubb adopts in effect the definition of a polarized ray as one which will produce an impulse on an atomic nucleus in a definite direction. Since when a cathode electron generates an X-ray quantum the impulse imparted to the nucleus is along  $BC$ , it is natural to suppose also that the quantum born in the process will have its "electric vector" in the direction  $-BC$ . On this view, the electric vector of the quantum must point within an angle  $2\theta$  defined by the tangents drawn through  $C$  to the circle  $\Omega$ . This angle  $\theta$  is given by

$$\cos^2 \theta = \frac{2h\nu\sqrt{1 - \beta_i^2(1 - \beta_i \cos \phi)}}{m\beta_i^2 c^2 \sin^2 \phi}. \quad (12.19)$$

The theory thus predicts partial polarization of the X-rays of all frequencies, but a greater polarization for the rays of higher frequency. For low frequencies the electric vector may be in almost any direction, whereas for high frequencies it is confined within a very acute angle. This prediction is in excellent agreement with the experiments, which show that by filtering out the soft rays from the primary beam the polarization can be considerably increased.

In considering the inverse theory of Bubb which deals with the direction of emission of the photoelectrons, we found a qualitative, but not a quantitative, agreement with the experiments. If the present theory is likewise found not to be in exact accord with the experiments it will probably mean that the impulse imparted to the atomic nucleus is not exactly in the direction assumed by Bubb. In any case his theory shows in a striking way the power of the concept of radiation quanta as applied to problems of the emission of radiation.

## APPENDICES



## APPENDIX I

### RADIATION FROM AN ELECTRON MOVING WITH A VELOCITY APPROACHING THAT OF LIGHT

(References: E. Cunningham, "The Principle of Relativity," Chapters IV, V and VI; A. Sommerfeld, "Atomic Structure and Spectral Lines," English translation, pp. 452-466.)

In view of the fact that we shall have frequent use throughout this work for the results of the special theory of relativity, it will be valuable to outline briefly the derivation of these results.

#### A. THE LORENTZ TRANSFORMATION EQUATIONS

##### 1. *Einstein's Derivation of the Fundamental Transformations.*

The relativity method of solving a problem relating to a body in motion is to solve first the problem for such a body when at rest, and then by the application of certain "transformation equations" find the corresponding solution for a body in motion. In deriving these transformation equations, Einstein imagines two similar systems,  $S$  and  $S'$ , the system  $S$  remaining at rest while the system  $S'$ , which was coincident with the system  $S$  at the instant  $t = 0$ , moves along the  $X$  axis with a velocity  $v$ . The equations are then derived by the use of two assumptions: (1) that the velocity of light has the same value  $c$  in both systems, and (2) that the changes between the variables  $x$ ,  $y$ ,  $z$  and  $t$  are linear, i.e., that the space is homogeneous and that the motion is unaccelerated.

The mathematical formulation of the second assumption is that

$$\begin{aligned}x' &= k(x - vt), & y' &= ly, \\z' &= lz, & t' &= \alpha x + \beta y + \gamma z + \delta t, \end{aligned} \quad (2)$$

where the primed coordinates refer to the moving system  $S'$ , the unprimed ones to the stationary system, and the coefficients  $k, l, \alpha, \beta, \gamma, \delta$  are functions only of the velocity. The coefficients of  $y$  and  $z$  are taken to be the same by symmetry, since the motion is perpendicular to both the  $Y$  and  $Z$  axes. An expression of the first assumption is that for a particle moving from the origin with the velocity of light,

$$x^2 + y^2 + z^2 = c^2 t^2 \quad (1)$$

is equivalent to

$$x'^2 + y'^2 + z'^2 = c^2 t'^2.$$

It is from these assumptions, equations (1) and (2), that all the transformation equations are derived.

If in the second of equations (1) we introduce the values of the primed coordinates given in equations (2), we obtain

$$k^2(x - vt)^2 + l^2 y^2 + l^2 z^2 = c^2(\alpha x + \beta y + \gamma z + \delta t)^2,$$

or on expanding and collecting coefficients,

$$\begin{aligned} (k^2 - c^2 \alpha^2)x^2 + (l^2 - c^2 \beta^2)y^2 + (l^2 - c^2 \gamma^2)z^2 \\ - 2c^2 \alpha \beta \cdot xy + 2c^2 \alpha \gamma \cdot xz - 2c^2 \beta \gamma \cdot yz \\ = (c^2 \delta^2 - k^2 v^2)t^2 + 2(k^2 v + c^2 \alpha \delta)xt + 2c^2 \beta \delta \cdot yt + 2c^2 \gamma \delta \cdot zt. \end{aligned}$$

But by our first assumption this is equivalent to

$$x^2 + y^2 + z^2 = c^2 t^2.$$

Since the particle may be assumed to move in any direction, the coordinates may be varied independently of each other, so that the coefficients of  $x, x^2, y, y^2$ , etc., in the two expressions must be equivalent to each other except for an arbitrary factor  $m^2$  by which both sides of the latter expression may be multiplied without changing its significance. Thus we have,

$$\begin{aligned} \alpha \beta = \alpha \gamma = \beta \gamma = \beta \delta = \gamma \delta = 0, & \quad k^2 v + c^2 \alpha \delta = 0, \\ k^2 - c^2 \alpha^2 = m^2, & \quad l^2 - c^2 \beta^2 = m^2, \\ l^2 - c^2 \gamma^2 = m^2, & \quad c^2 \delta^2 - k^2 v^2 = m^2 c^2. \end{aligned}$$

It follows that

$$\begin{aligned}\beta &= \gamma = 0, & \alpha &= -kv/c^2, & \delta &= k, \\ k &= \left(1 - \frac{v^2}{c^2}\right)^{-1/2} m, & & & l &= m.\end{aligned}$$

Our simplest assumption is that  $m = 1$ , which merely means that we are measuring distances on the same scale in the two systems. For at the instant at which the  $Y'Z'$  plane of the system  $S'$  is coincident with the  $YZ$  plane of the system  $S$ , the corresponding points in the two planes coincide, that is,

$$y' = y \quad \text{and} \quad z' = z.$$

Introducing this value of  $m$ , therefore,

$$\begin{aligned}k &= \left(1 - \frac{v^2}{c^2}\right)^{-1/2}, \quad l = 1, \quad \alpha = -\frac{v}{c^2}k, \\ \beta &= \gamma = 0, & \delta &= k.\end{aligned} \quad (3)$$

Consequently by equations (2),

$$x' = (x - vt)k, \quad y' = y, \quad z' = z, \quad t' = k(t - vx/c^2). \quad (4)$$

On solving for  $x$ ,  $y$ ,  $z$  and  $t$ , we find conversely,

$$x = (x' + vt')k, \quad y = y', \quad z = z', \quad t = k(t' + vx'/c^2). \quad (4')$$

## 2. Displacement, Velocity and Acceleration

Consider two points whose coordinates at the instant  $t$  in the stationary system are  $x_1, y_1, z_1$  and  $x_2, y_2, z_2$ . In the moving system the distance between the two points, as measured along the three axes, is by equation (4),

$$\left. \begin{aligned}x_2' - x_1' &= k(x_2 - vt) - k(x_1 - vt) = k(x_2 - x_1) \\ y_2' - y_1' &= y_2 - y_1 \\ z_2' - z_1' &= z_2 - z_1\end{aligned} \right\} \quad (5)$$

To an observer moving with the system  $S'$ , though the distances along the  $Y$  and  $Z$  axes remain unchanged, the distance along the direction of motion thus appears to be shortened by the factor  $k$ . Conversely, if two points in the moving system

are a distance  $x_2' - x_1'$  apart, application of equation (4') shows that in the system at rest their separation is  $x_2 - x_1 = k(x_2' - x_1')$ . This apparent contraction in the direction of motion is that postulated originally by Fitzgerald to account for the results of the Michelson Morley experiment.

*Addition of Velocities.*—Imagine a particle which is moving with a velocity whose components, as measured in the stationary system, are  $u_x, u_y$  and  $u_z$ . The  $X$  component of the velocity in the system  $S'$  is then  $dx'/dt'$ , where

$$dx' = dk(x - vt) = k(dx - vdt),$$

and

$$dt' = dk\left(t - \frac{vx}{c^2}\right) = k\left(dt - \frac{vdx}{c^2}\right).$$

Thus

$$\begin{aligned} u_x' &= \frac{dx'}{dt'} = \frac{dx - vdt}{dt - \frac{v}{c^2}dx} = \frac{\frac{dx}{dt} - v}{1 - \frac{v}{c^2}\frac{dx}{dt}} \\ &= \frac{u_x - v}{1 - \frac{v}{c^2}u_x}. \end{aligned} \quad (6)$$

Similarly we find,

$$u_y' = \frac{u_y}{k\left(1 - \frac{v}{c^2}u_x\right)} \quad \text{and} \quad u_z' = \frac{u_z}{k\left(1 - \frac{v}{c^2}u_x\right)}. \quad (7)$$

Conversely we can show that if as measured in system  $S'$  the particle's velocity components are  $u_x', u_y'$  and  $u_z'$ , in system  $S$  its velocity is given by

$$u_x = \frac{u_x' + v}{1 + \frac{v}{c^2}u_x'} \quad (6')$$

$$u_y = \frac{u_y'}{k\left(1 - \frac{v}{c^2}u_x'\right)} \quad \text{and} \quad u_z = \frac{u_z'}{k\left(1 - \frac{v}{c^2}u_x'\right)}. \quad (7')$$

From equation (6') we see that the velocity  $u_x$  of a particle moving with a velocity  $u_x'$  relative to the system  $S'$ , which itself is moving with a velocity  $v$ , is less than  $u_x' + v$ , and is always less than  $c$  if both  $u_x'$  and  $v$  are less than  $c$ . For velocities comparable with that of light, therefore, the simple rules of vector addition cannot be applied. We also see that  $c$  represents a limiting velocity which cannot be exceeded by a particle which gains velocity in increments less than  $c$ . An interesting and important confirmation of this result is that whereas  $\beta$ -particles ejected by radioactive materials have been found to have velocities up to  $0.998c$ , none have ever been observed with velocities greater than  $c$ .

*Accelerations.*—We define the acceleration of the particle as measured in the stationary system as the vector having the components  $a_x = du_x/dt$ ,  $a_y = du_y/dt$  and  $a_z = du_z/dt$ . As measured from the moving axes,

$$\begin{aligned} du_x' &= d \left\{ \frac{u_x - v}{1 - \frac{vu_x}{c^2}} \right\} \\ &= \frac{du_x}{k^2 \left( 1 - \frac{vu_x}{c^2} \right)^2} \end{aligned}$$

But we have seen that

$$\begin{aligned} dt' &= k \left( dt - \frac{v}{c^2} dx \right) = k \left( dt - \frac{v}{c^2} u_x dt \right) \\ &= dt \cdot k \left( 1 - \frac{vu_x}{c^2} \right). \end{aligned}$$

Thus

$$a_x' = \frac{du_x'}{dt'} = \frac{du_x}{dt} \cdot \frac{1}{k^2 \left( 1 - \frac{vu_x}{c^2} \right)^3}.$$

If we write

$$\phi = k \left( 1 - \frac{vu_x}{c^2} \right),$$

then

$$a_x' = \frac{1}{\phi^3} a_x. \quad (8)$$

In a similar manner we can show that

$$\begin{aligned} a_y' &= \frac{1}{\phi^2} a_y + \frac{kvu_y}{\phi^3 c^2} a_x, \\ a_z' &= \frac{1}{\phi^2} a_z + \frac{kvu_z}{\phi^3 c^2} a_x. \end{aligned} \quad (9)$$

### 3. *The Electromagnetic Field*

In the stationary system the equations of the electromagnetic field are:

$$\frac{1}{c} \frac{\partial E_x}{\partial t} + 4\pi\rho \frac{u_x}{c} = \frac{\partial H_z}{\partial y} - \frac{\partial H_y}{\partial z}, \quad (A)$$

$$\frac{1}{c} \frac{\partial E_y}{\partial t} + 4\pi\rho \frac{u_y}{c} = \frac{\partial H_x}{\partial z} - \frac{\partial H_z}{\partial x}, \quad (B)$$

$$\frac{1}{c} \frac{\partial E_z}{\partial t} + 4\pi\rho \frac{u_z}{c} = \frac{\partial H_y}{\partial x} - \frac{\partial H_x}{\partial y}, \quad (C)$$

$$-\frac{1}{c} \frac{\partial H_x}{\partial t} = \frac{\partial E_z}{\partial y} - \frac{\partial E_y}{\partial z}, \quad (D)$$

$$-\frac{1}{c} \frac{\partial H_y}{\partial t} = \frac{\partial E_x}{\partial z} - \frac{\partial E_z}{\partial x}, \quad (E)$$

$$-\frac{1}{c} \frac{\partial H_z}{\partial t} = \frac{\partial E_y}{\partial x} - \frac{\partial E_x}{\partial y}, \quad (F)$$

$$\frac{\partial E_x}{\partial x} + \frac{\partial E_y}{\partial y} + \frac{\partial E_z}{\partial z} = 4\pi\rho, \quad (G)$$

$$\frac{\partial H_x}{\partial x} + \frac{\partial H_y}{\partial y} + \frac{\partial H_z}{\partial z} = 0.$$

In these equations  $E$  is the electric intensity expressed in e.s.u.,  $H$  is the magnetic intensity in e.m.u., and  $\rho$  is the volume density of electrification. In order to express the corresponding relations as referred to the moving system  $S'$ , let us consider the partial derivatives of any function  $\Psi$  of the coordinates  $x, y, z$  and  $t$ . By virtue of equations (4) and (4') we have:

$$\begin{aligned}\frac{\partial \Psi}{\partial x} &= \frac{\partial \Psi}{\partial x'} \frac{dx'}{dx} + \frac{\partial \Psi}{\partial t'} \frac{dt'}{dx} = \frac{\partial \Psi}{\partial x'} k - \frac{\partial \Psi}{\partial t'} k \frac{v}{c^2} \\ &= k \left( \frac{\partial \Psi}{\partial x'} - \frac{v}{c^2} \frac{\partial \Psi}{\partial t'} \right); \\ \frac{\partial \Psi}{\partial y} &= \frac{\partial \Psi}{\partial y'}; \quad \frac{\partial \Psi}{\partial z} = \frac{\partial \Psi}{\partial z'}; \\ \frac{\partial \Psi}{\partial t} &= \frac{\partial \Psi}{\partial t'} \frac{dt'}{dt} + \frac{\partial \Psi}{\partial x'} \frac{dx'}{dt} = k \left( \frac{\partial \Psi}{\partial t'} - v \frac{\partial \Psi}{\partial x'} \right).\end{aligned}$$

Expressing equations (A), (B), and (C) in terms of  $x', y', z'$  and  $t'$  by the use of these relations we obtain,

$$\frac{k}{c} \frac{\partial E_x}{\partial t'} - \frac{kv}{c} \frac{\partial E_x}{\partial x'} + 4\pi\rho \frac{u_x}{c} = \frac{\partial H_z}{\partial y'} - \frac{\partial H_y}{\partial z'}, \quad (a)$$

$$\frac{k}{c} \frac{\partial E_y}{\partial t'} - \frac{kv}{c} \frac{\partial E_y}{\partial x'} + 4\pi\rho \frac{u_y}{c} = \frac{\partial H_x}{\partial z'} - k \frac{\partial H_z}{\partial x'} + \frac{kv}{c^2} \frac{\partial H_x}{\partial t'}, \quad (b)$$

$$\frac{k}{c} \frac{\partial E_z}{\partial t'} - \frac{kv}{c} \frac{\partial E_z}{\partial x'} + 4\pi\rho \frac{u_z}{c} = k \frac{\partial H_y}{\partial x'} - \frac{kv}{c^2} \frac{\partial H_y}{\partial t'} - \frac{\partial H_x}{\partial y'}. \quad (c)$$

It is an essential assumption of the theory of relativity that physical laws have the same form whether expressed in the coordinates of system  $S'$  or in those of system  $S$ . For if this were not true, by the form of the physical law it should be possible to determine the state of motion of the system. It will be seen that our assumption (I) is a special case of this more general principle. We accordingly seek for quantities  $E', H'$  and  $\rho'$  which will be related to  $E, H$  and  $\rho$  in such a way that when substituted in equations (a), (b), (c), etc., these will

be of the same form as equations (A), (B), (C), etc. The desired values are:

$$\left. \begin{aligned} E_x' &= E_x; & E_y' &= k\left(E_y - \frac{v}{c}H_z\right); & E_z' &= k\left(E_z + \frac{v}{c}H_y\right); \\ H_x' &= H_x; & H_y' &= k\left(H_y + \frac{v}{c}E_z\right); & H_z' &= k\left(H_z - \frac{v}{c}E_y\right); \end{aligned} \right\} \quad (10)$$

and the equivalent reciprocal expressions are,

$$\left. \begin{aligned} E_y &= k\left(E_y' + \frac{v}{c}H_z'\right); & E_z &= k\left(E_z' - \frac{v}{c}H_y'\right); \\ H_y &= k\left(H_y' - \frac{v}{c}E_z'\right); & H_z &= k\left(H_z' + \frac{v}{c}E_y'\right); \end{aligned} \right\} \quad (10')$$

also

$$\rho' = k\rho\left(1 - \frac{vu_x}{c^2}\right); \quad \rho = k\rho'\left(1 + \frac{vu_x'}{c^2}\right). \quad (11)$$

When these values for  $E$ ,  $H$  and  $\rho$  are inserted in equations (b) and (c), using the values of  $u_y$  and  $u_z$  given by equations (7'), we obtain, after some reduction,

$$\frac{1}{c} \frac{\partial E_y'}{\partial t'} + 4\pi\rho' \frac{u_y'}{c} = \frac{\partial H_x'}{\partial z'} - \frac{\partial H_z'}{\partial x'}, \quad (B')$$

$$\frac{1}{c} \frac{\partial E_z'}{\partial t'} + 4\pi\rho' \frac{u_z'}{c} = \frac{\partial H_y'}{\partial x'} - \frac{\partial H_x'}{\partial y'}. \quad (C')$$

These are of precisely the same form as equations (B) and (C).

The substitution in equation (a) is somewhat complex. Introducing the new values for  $E$  and  $H$  we obtain directly

$$\frac{k}{c} \left\{ \frac{\partial E_x'}{\partial t'} - v \left( \frac{\partial E_x'}{\partial x'} + \frac{\partial E_y'}{\partial y'} + \frac{\partial E_z'}{\partial z'} \right) \right\} + 4\pi\rho \frac{u_x}{c} = k \left( \frac{\partial H_z'}{\partial y'} - \frac{\partial H_y'}{\partial z'} \right).$$

But from equation (G) we get,

$$\frac{kv}{c} \left( \frac{\partial E_x'}{\partial x'} + \frac{\partial E_y'}{\partial y'} + \frac{\partial E_z'}{\partial z'} \right) - \frac{kv^2}{c^2} \frac{\partial E_x'}{\partial t'} - \frac{kv^2}{c^2} \left( \frac{\partial H_y'}{\partial z'} - \frac{\partial H_z'}{\partial y'} \right) = 4\pi\rho \frac{v}{c}.$$

Thus

$$\frac{\partial E_x'}{\partial t'} \frac{k}{c} \left(1 - \frac{v^2}{c^2}\right) - 4\pi\rho \frac{v}{c} + 4\pi\rho \frac{u_x}{c} = k \left(1 - \frac{v^2}{c^2}\right) \left(\frac{\partial H_z'}{\partial y'} - \frac{\partial H_y'}{\partial z'}\right),$$

or

$$\frac{1}{c} \frac{\partial E_x'}{\partial t'} - k \frac{4\pi\rho}{c} (v + u_x) = \frac{\partial H_z'}{\partial y'} - \frac{\partial H_y'}{\partial z'},$$

since  $(1 - v^2/c^2) = 1/k^2$ . Introducing the values of  $\rho$  and  $u_x$  given by equations (11) and (6') we then have at once,

$$\frac{1}{c} \frac{\partial E_x'}{\partial t'} + 4\pi\rho' \frac{u_x'}{c} = \frac{\partial H_z'}{\partial y'} - \frac{\partial H_y'}{\partial z'}, \quad (A')$$

which is identical in form with equation (A).

In a similar manner it can be shown that, using the values of  $E$ ,  $H$  and  $\rho$  given by equations (10) and (11), equations (D) (E), (F), (G) and (H) transform into precisely similar equations in the system  $S'$ . Thus expressions (10) and (11) are the desired transformation equations for the electromagnetic field.

*Constancy of Electric Charge.*—If we consider a volume element moving with system  $S'$  with a velocity  $u_x = v$ , whose edges are  $x'$ ,  $y'$ ,  $z'$ , and which contains an electric charge of volume density  $\rho'$ , the total charge within the element as measured in system  $S'$  is  $\rho' \delta x' \delta y' \delta z'$ . From equation (4) and (11), however,

$$\begin{aligned} \rho' \delta x' \delta y' \delta z' &= k\rho \left(1 - \frac{v^2}{c^2}\right) \cdot k \delta x \delta y \delta z \\ &= \rho \delta x \delta y \delta z \\ &= \text{charge measured in system } S, \end{aligned} \quad (12)$$

since

$$(1 - v^2/c^2) = 1/k^2.$$

Thus an electric charge has the same value whether referred to axes at rest or to axes moving with the charge.

4. *Variation of Mass with Velocity*

Let us consider a particle, whose mass when at rest is  $m_0$ , moving in the  $XY$  plane, with a velocity which at the instant  $t = 0$  is the same as that of the moving system  $S'$ . In this system the components of the force acting on the particle are let us say  $X'$ ,  $Y'$ , whence by Newton's second law of motion,

$$\frac{d}{dt'}\left(m' \frac{dx'}{dt'}\right) = X', \quad \text{and} \quad \frac{d}{dt'}\left(m' \frac{dy'}{dt'}\right) = Y'. \quad (13)$$

At the initial instant  $m' = m_0$ , and  $dx'/dt' = dy'/dt' = 0$ , so that

$$m_0 \frac{d^2x'}{dt'^2} = X' \quad \text{and} \quad m_0 \frac{d^2y'}{dt'^2} = Y'. \quad (14)$$

But from equations (8) and (9), noting that  $u_x = v$ ,  $u_y = 0$ , and  $\phi = 1/k$  where  $k = 1/\sqrt{1 - v^2/c^2}$ , we find

$$\frac{d^2x'}{dt'^2} = k^3 \frac{d^2x}{dt^2}, \quad \text{and} \quad \frac{d^2y'}{dt'^2} = k^2 \frac{d^2y}{dt^2}. \quad (15)$$

Let us suppose that the force  $X'$ ,  $Y'$  is that due to an electric field of components  $E_x'$  and  $E_y'$  acting on a charge  $e$  on the particle. Then noting that the charge  $e$  has the same value in both systems, whereas by equations (10)  $E_x' = E_x$  and  $E_y' = E_y$ , since  $H_x = 0$ , the components of the force are

$$X' = E_x' e = E_x e = X,$$

and

$$Y' = E_y' e = k E_y e = k Y. \quad (16)$$

Substituting from equations (15) and (16) in equation (14) we get

$$k^3 m_0 \frac{d^2x}{dt^2} = X \quad \text{and} \quad k m_0 \frac{d^2y}{dt^2} = Y. \quad (17)$$

The quantities  $k^3 m_0$  and  $k m_0$  are (or have been) frequently though incorrectly referred to respectively as the longitudinal and the transverse mass. The fundamental definition of mass is however not the coefficient of the acceleration in the expres-

sion for the force, as this would imply, but rather the coefficient of the velocity in the expression for the momentum, or what Newton calls the "quantity of motion." That is, the mass is correctly defined by relations similar to equation (15), namely,

$$\frac{d}{dt}\left(m\frac{dx}{dt}\right) \equiv X, \quad \text{and} \quad \frac{d}{dt}\left(m\frac{dy}{dt}\right) \equiv Y. \quad (18)$$

If in equations (18) we use  $m = km_0$ , we get

$$X = \frac{d}{dt}\left(km_0\frac{dx}{dt}\right) = km_0\frac{d^2x}{dt^2} + m_0\frac{dx}{dt}\frac{dk}{dt},$$

$$Y = \frac{d}{dt}\left(km_0\frac{dy}{dt}\right) = km_0\frac{d^2y}{dt^2} + m_0\frac{dy}{dt}\frac{dk}{dt}.$$

But

$$\frac{dk}{dt} = \frac{d}{dt}\left(1 - \frac{v^2}{c^2}\right)^{-1/2} = \frac{v}{c^2}\left(1 - \frac{v^2}{c^2}\right)^{-3/2}\frac{dv}{dt} = k^3\frac{v}{c^2}\frac{d^2x}{dt^2}, \quad (19)$$

also  $dx/dt = v$ , and  $dy/dt = 0$ . Thus,

$$X = km_0\frac{d^2x}{dt^2} + k^3m_0\frac{v^2}{c^2}\frac{d^2x}{dt^2} = k^3m_0\frac{d^2x}{dt^2}\left\{\left(1 - \frac{v^2}{c^2}\right) + \frac{v^2}{c^2}\right\}$$

$$= k^3m_0\frac{d^2x}{dt^2},$$

$$Y = km_0\frac{d^2y}{dt^2}.$$

These expressions are identical with equations (17), showing that the mass, as defined by equation (18), is given by

$$m = km_0 = m_0/\sqrt{1 - \beta^2}, \quad (20)$$

where  $\beta = v/c$ .

*Kinetic Energy.*—Imagine a particle of rest mass  $m_0$  moving along the  $X$  axis with a velocity  $v = \beta c$ , and acted on by a force of magnitude  $X$ . The rate at which this force does work, increasing the kinetic energy  $T$  of the particle, is

$$X\frac{dx}{dt} = \frac{dT}{dt}.$$

Using the value of  $X$  given by equation (17), this expression becomes,

$$\begin{aligned}\frac{dT}{dt} &= \frac{dx}{dt} \cdot k^3 m_0 \frac{d^2x}{dt^2} \\ &= m_0 c^2 k^3 \beta \frac{d\beta}{dt}.\end{aligned}$$

But by (19)

$$\frac{dk}{dt} = k^3 \frac{v}{c^2} \frac{d^2x}{dt^2} = k^3 \beta \frac{d\beta}{dt}.$$

Thus

$$\frac{dT}{dt} = m_0 c^2 \frac{dk}{dt},$$

whence

$$T = km_0 c^2 + \text{const.}$$

Since  $T = 0$  when  $v = 0$  or when  $k = 1$ ,  $\text{const} = -m_0 c^2$ . Therefore

$$\begin{aligned}T &= m_0 c^2 (k - 1) \\ &= m_0 c^2 \left( \frac{1}{\sqrt{1 - \beta^2}} - 1 \right).\end{aligned}\quad (21)$$

If this is expanded into a series, recalling that  $\beta = v/c$ , we obtain

$$T = \frac{1}{2} m v^2 \left( 1 + \frac{3}{4} \beta^2 + \frac{5}{8} \beta^4 + \dots \right). \quad (22)$$

For small velocities, this calculation therefore gives the same value  $\frac{1}{2} m v^2$  as is employed in the usual mechanics.

*The Inertia of Energy.*—Equation (21) may be written, since  $km_0 = m$ , as

$$T = c^2 (m - m_0), \quad \text{or} \quad m - m_0 = T/c^2.$$

That is, the increase in the mass of the body due to its motion is equal to the energy due to its motion divided by  $c^2$ .

This is one example of a general principle propounded by Einstein as the result of an extensive application of the principles of special relativity to a large variety of problems. His

conclusion is: every quantity of energy, of any kind whatever, has associated with it an amount of mass

$$M = W/c^2, \quad (23)$$

where  $W$  is the amount of energy.

A corollary to this proposition is that, since momentum is defined as mass  $\times$  velocity, if a quantity of energy is moving with a velocity  $v$ , it carries with it an amount of momentum

$$p = Wv/c^2. \quad (24)$$

An important application of this corollary is to the case of radiant energy, propagated in a definite direction with a velocity  $c$ . In this case the momentum  $p$  carried by the radiant energy  $W$  is

$$p = W/c, \quad (25)$$

a result identical with that required according to electromagnetic theory to account for radiation pressure.

In the following table are collected the more important transformation equations.

TABLE I

Transformation equations from system  $S$  at rest to system  $S'$  moving along  $X$  axis with velocity  $v = \beta c$ , and vice versa:

$$\beta \equiv \frac{v}{c}; \quad k \equiv (1 - \beta^2)^{-1/2}; \quad \phi \equiv k \left(1 - \frac{v u_x}{c^2}\right); \quad \phi' \equiv k \left(1 + \frac{v u_x'}{c^2}\right).$$

Displacement:

$$\begin{aligned} x' &= k(x - vt), & x &= k(x' + vt'), \\ y' &= y, & z' &= z, \\ t' &= k \left(t - \frac{vx}{c^2}\right), & t &= k \left(t' + \frac{vx'}{c^2}\right). \end{aligned} \quad (4)$$

Velocity:

$$u_x' = \frac{k}{\phi}(u_x - v), \quad u_x = \frac{k}{\phi'}(u_x' + v), \quad (6)$$

$$\begin{aligned} u_y' &= u_y/\phi, & u_y &= u_y'/\phi', \\ u_z &= u_z/\phi, & u_z &= u_z'/\phi'. \end{aligned} \quad (7)$$

Acceleration:

$$\begin{aligned}
 a_x' &= a_x / \phi^3, & a_x &= a_x' / \phi'^3, \\
 a_y' &= \frac{a_y}{\phi^2} + \frac{kvu_y}{\phi^3 c^2} a_x, & a_y &= \frac{a_y'}{\phi'^2} - \frac{kvu_y'}{\phi'^3 c^2} a_x', \\
 a_z' &= \frac{a_z}{\phi^2} + \frac{kvu_z}{\phi^3 c^2} a_x, & a_z &= \frac{a_z'}{\phi'^2} - \frac{kvu_z'}{\phi'^3 c^2} a_x'.
 \end{aligned} \tag{9}$$

Electromagnetic Field:

$$\begin{aligned}
 E_x' &= E_x, & E_x &= E_x', \\
 E_y' &= k(E_y - \beta H_z), & E_y &= k(E_y' + \beta H_z'), \\
 E_z' &= k(E_z + \beta H_y), & E_z &= k(E_z' - \beta H_y'),
 \end{aligned} \tag{10}$$

$$\begin{aligned}
 H_x' &= H_x, & H_x &= H_x', \\
 H_y' &= k(H_y + \beta E_z), & H_y &= k(H_y' - \beta E_z'), \\
 H_z' &= k(H_z - \beta E_y), & H_z &= k(H_z + \beta E_y). \\
 \rho' &= \phi \rho, & \rho &= \phi' \rho',
 \end{aligned} \tag{11}$$

$$e = e' \tag{12}$$

Dynamics:

$$\begin{aligned}
 m &= km_0 \quad (20); & T &= m_0 c^2 (k - 1) \quad (21); & M &= W / c^2 \quad (23); \\
 p &= Wv / c^2 \quad (24); & p_{\text{radiation}} &= W / c \quad (25).
 \end{aligned}$$

## B. FIELD DUE TO ELECTRON ACCELERATED IN DIRECTION OF MOTION

In Chapter II we showed that if an electron moving with negligible velocity is accelerated along the  $X$  axis, an electric field results whose intensity is

$$E = H = \frac{ae}{rc^2} \sin \theta. \tag{2.05}$$

In order to calculate the radiation from this electron when moving with a velocity  $v$ , we imagine the system  $S'$  moving with the electron at the moment  $t = 0$  with the uniform velocity  $v$ . Referred to this system the electron is at this instant at rest, so that the field due to the radiation is,

$$E' = H' = \frac{a'e \sin \theta'}{r'c^2}. \tag{26}$$

Referring to Fig. 131, it will be seen that

$$\begin{aligned} E_x' &= -E' \sin \theta'; & E_y' &= E' \cos \theta'; & E_z' &= 0; \\ H_x' &= 0; & H_y' &= 0; & H_z' &= H'. \end{aligned} \quad (27)$$

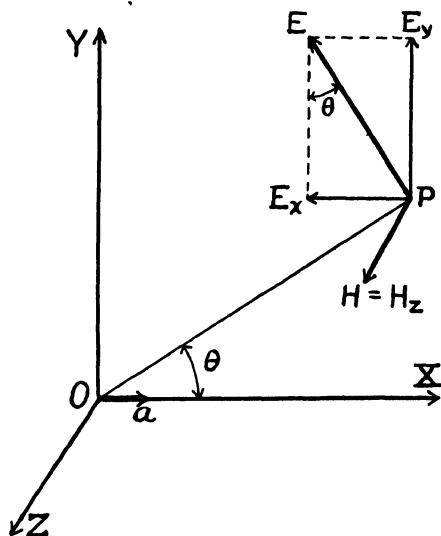

FIG. 131.

By equations (10), therefore,

$$\begin{aligned} E_x &= E_x' = -\frac{e}{c^2} \frac{a'}{r'} \sin^2 \theta', \\ E_y &= k \left( \frac{e}{c^2} \frac{a'}{r'} \sin \theta' \cos \theta' + \beta \frac{e}{c^2} \frac{a'}{r'} \sin \theta' \right), \\ E_z &= 0, & H_x &= 0, & H_y &= 0, \\ H_z &= k \left( \frac{e}{c^2} \frac{a'}{r'} \sin \theta' + \beta \frac{e}{c^2} \frac{a'}{r'} \sin \theta' \cos \theta' \right). \end{aligned} \quad (28)$$

To complete the transformation, we note from equation (8), since  $u_x = v$  and thus  $\phi = 1/k$ , that

$$a' = a_x' = k^3 a_x = k^3 a. \quad (29)$$

Also, from equation (4),

$$r' = \sqrt{x'^2 + y'^2} = \sqrt{k^2(x^2 - 2vxt + v^2t^2) + y^2},$$

where  $t$ , the time at which the field is evaluated at  $P$  (Fig. 1) is  $r/c$ . Thus

$$\begin{aligned} r' &= \sqrt{k^2(x^2 - 2xv\frac{r}{c} + v^2r^2/c^2) + y^2}, \\ &= k\sqrt{x^2 - 2\beta xr + \beta^2r^2 + y^2 - \beta^2y^2}, \\ &= k(r - \beta x). \end{aligned} \quad (30)$$

$$\sin \theta' = \frac{y'}{r'} = \frac{y}{k(r - \beta x)} = \frac{\sin \theta}{k(1 - \beta \cos \theta)}, \quad (31)$$

$$\cos \theta' = \sqrt{1 - \sin^2 \theta'} = \frac{\cos \theta - \beta}{1 - \beta \cos \theta}. \quad (32)$$

Substituting these values in equations (28) we get

$$E_x = -\frac{e a}{c^2 r} \frac{\sin^2 \theta}{(1 - \beta \cos \theta)^3},$$

$$E_y = \frac{e a}{c^2 r} \frac{\sin \theta \cos \theta}{(1 - \beta \cos \theta)^3},$$

or

$$\left. \begin{aligned} E &= \sqrt{E_x^2 + E_y^2} = \frac{ea}{rc^2} \frac{\sin \theta}{(1 - \beta \cos \theta)^3}; \\ \text{and} \\ H &= H_x = \frac{ea}{rc^2} \frac{\sin \theta}{(1 - \beta \cos \theta)^3}. \end{aligned} \right\} \quad (33)$$

The equations (33), representing the field due to a charge in accelerated motion along the axis, are those employed in Chapter II as equations (2.08). They were used by Sommerfeld ("Atomic Structure and Spectral Lines," pp. 33 and 532) in discussing the pulse theory of X-rays.

## APPENDIX II

### EXPRESSION OF A PULSE AS A FOURIER INTEGRAL

(Cf. page 48)

In textbooks on mathematics (cf. e.g., W. E. Byerly, *An Elementary Treatise on Fourier Series*, J. W. Mellor, *Higher Mathematics*, etc., p. 479, or R. A. Houstoun, *Introduction to Mathematical Physics*, p. 99), it is shown that a function of  $x$  may be expressed as a double integral, known as Fourier's integral, thus:

$$y = f(x) = \frac{1}{\pi} \int_0^{\infty} d\omega \int_{-\infty}^{\infty} f(u) \cos \omega(u - x) du. \quad (1)$$

On page 48 we considered an electric pulse which had a value  $E$  for a time  $2t$  or for a thickness  $l = 2ct$ , and which was zero at other times. If in equation (1) we allow  $x$  to represent the time  $t$ , we may represent this pulse as

$$\begin{aligned} y = f(t) &= E \text{ for } -\tau < t < \tau \\ &= 0 \text{ for } t < -\tau \text{ and } t > \tau. \end{aligned}$$

Equation (1) then becomes,

$$y = \frac{1}{\pi} \int_0^{\infty} d\omega \int_{-\tau}^{\tau} E \cos \omega(u - x) du.$$

Integrating with respect to  $u$  this becomes,

$$y = \frac{E}{\pi} \int_0^{\infty} d\omega \cdot \frac{2}{\omega} \sin \omega \tau \cos \omega t. \quad (2)$$

If we write  $\omega = 2\pi\nu$ , this becomes

$$y = \frac{2E}{\pi} \int_0^{\infty} d\nu \frac{\sin 2\pi\nu\tau}{\nu} \cos 2\pi\nu t. \quad (3)$$

It will be seen that this equation expresses  $y$  as an integral of waves whose frequencies vary continuously from  $\nu = 0$  to  $\nu = \infty$ .

The amplitude of the wave of frequency  $\nu$ , according to equation (3), is proportional to

$$\frac{\sin 2\pi\nu\tau}{\nu},$$

and since the intensity of the wave is proportional to the square of the amplitude, we have for the intensity of the radiation of frequency between  $\nu$  and  $\nu + d\nu$ ,

$$I_\nu d\nu \propto \frac{\sin^2 2\pi\nu\tau}{\nu^2} d\nu. \quad (4)$$

Writing  $\nu = c/\lambda$ , and  $d\nu = -cd\lambda/\lambda^2$ , we obtain

$$I_\lambda d\lambda \propto \sin^2 (2\pi c\tau/\lambda) d\lambda,$$

or

$$I_\lambda d\lambda = K \sin^2 \pi \frac{l}{\lambda} d\lambda, \quad (5)$$

where  $K$  is a constant of proportionality and  $2ct$  is written as  $l$ , the thickness of the pulse. This is the expression used in the text as equation (2.12).

## APPENDIX III

### ATOMIC AND ELECTRONIC CONSTANTS <sup>1</sup>

Quantity	Value	Uncertainty
$c$ Velocity of light.....	$2.9986 \times 10^{10}$ cm. sec <sup>-1</sup>	.0003
$e$ Electronic charge.....	$4.774 \times 10^{-10}$ e.s.u.	.005
$e/m$ Electronic ratio.....	$1.769 \times 10^7$ e.m.u.g. <sup>-1</sup>	.003
$h$ Planck's constant.....	$6.554 \times 10^{-27}$ erg sec	.006
$N$ Avogadro's number.....	$6.061 \times 10^{23}$ mole. <sup>-1</sup>	.006
$k$ Boltzmann's gas constant.....	$1.372 \times 10^{-16}$ erg deg. <sup>-1</sup>	
$m$ Electronic mass.....	$8.999 \times 10^{-28}$ g.	.01
$hc/e$ Photoelectric constant.....	$1.234 \times 10^4$ volt Ångströms	
$R_{\infty}$ Rydberg frequency.....	$3.2775 \times 10^{15}$ sec <sup>-1</sup>	
$h/mc$ Quantum constant.....	$2.421 \times 10^{-10}$ cm.	
$e^2/mc^2$ Electron constant.....	$2.816 \times 10^{-13}$ cm.	
$\sigma_0$ Thomson scattering per electron	$6.65 \times 10^{-26}$ cm. <sup>2</sup>	
$\alpha$ Sommerfeld's constant.....	$7.29 \times 10^{-3}$	
$D_{NaCl}$ Grating space rock-salt.....	$2.8144 \times 10^{-8}$ cm.	.0009
$D_{CaCO_3}$ Grating space calcite.....	$3.0288 \times 10^{-8}$ cm.	.0010

<sup>1</sup>The values of the basic constants here given have been taken from *The International Critical Tables* (1926).

## APPENDIX IV

### SCATTERING BY A PAIR OF ELECTRONS

Imagine, as in Fig. 132, that a beam of X-rays, of wavelength  $\lambda$  and frequency  $\nu = p/2\pi$ , is moving in the direction  $OX$ , and traverses two electrons  $e_1$  and  $e_2$  separated by a dis-

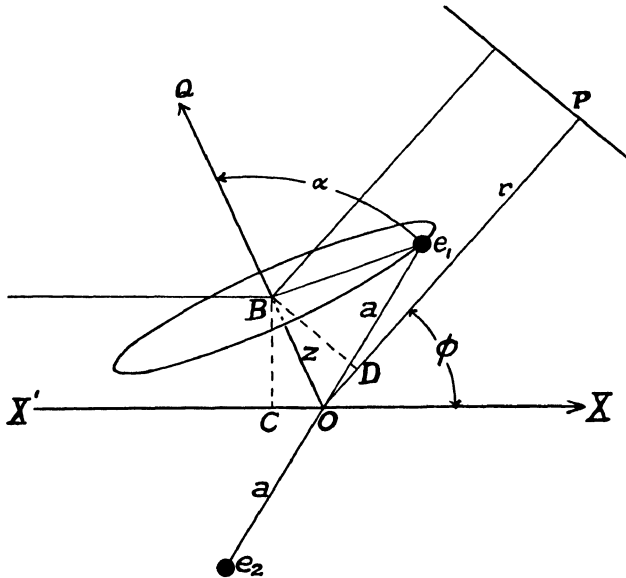

FIG. 132.

tance  $s = 2a$ . Take the point  $O$ , midway between these electrons, and let  $OP$  be the direction of the scattered beam which we are considering. The plane  $POX$  is in the plane of the paper, but in general the line  $e_1Oe_2$  does not lie in this plane. Its position can be defined with sufficient precision by stating that it is at an angle  $\alpha$  with the line  $OQ$  which bisects the angle  $X'OP$ .

Suppose the electric intensity at  $O$  of the component of the incident wave which lies in the plane  $XOP$  is

$$E_{II} = A \cos (pt + \delta).$$

If an electron were at  $O$ , its acceleration would be  $E_{II}/m$ , and the electric intensity at  $P$  at the time  $t$  would be, by equation (2-16),

$$E_{p0} = \frac{e \cos \phi}{rc^2} \cdot \frac{Ae}{m} \cos \left\{ p \left( t - \frac{r}{c} \right) + \delta \right\}$$

where, as compared with equation (2-16),  $\phi = \frac{\pi}{2} - \theta$ , and  $Ae/m = Ap^2 =$  the maximum acceleration of the electron. Since  $pr/c$  is the constant phase difference between  $O$  and  $P$ , we may write  $\delta - pr/c = \Delta$ , and our expression becomes,

$$E_{p0} = \frac{Ae^2 \cos \phi}{rmc^2} \cos (pt + \Delta). \tag{1}$$

If a plane is described through  $e_1$  perpendicular to  $OQ$  and intersecting this line at  $B$ , it will be seen from Huyghen's principle that wherever in this plane the electron lies, the phase of the wave scattered to the plane  $P$  will be the same. Thus the phase is the same as if the electron were at  $B$ . But from  $B$  the total length of the path of the ray reaching  $P$  is greater than that from  $O$  by the distance  $COD$ . Since  $\angle CBO = \angle OBD = \phi/2$ , and writing  $OB = Z$ , this difference in path is

$$COD = 2z \sin \frac{\phi}{2}.$$

The phase difference at  $P$  between rays scattered from these two points is therefore  $\frac{2\pi}{\lambda} \cdot 2z \sin \frac{\phi}{2}$ . The electric intensity at  $P$  due to the electron  $e$ , is accordingly

$$E_{p1} = A\phi \cos \left( pt + \Delta + \frac{4\pi z}{\lambda} \sin \frac{\phi}{2} \right), \tag{2}$$

$\lambda \phi$

where, as compared with equation (1) we have written

$$A_\phi = \frac{Ae^2 \cos \phi}{rmc^2}.$$

But the path of the ray scattered from  $e_2$  is obviously greater than that from  $O$  by the same amount that the path from  $O$  is greater than that from  $e_1$ . Thus the electric intensity at  $P$  due to the ray scattered from  $e_2$  is

$$E_{p2} = A_\phi \cos \left( pt + \Delta - \frac{4\pi z}{\lambda} \sin \frac{\phi}{2} \right). \quad (3)$$

Putting  $a = pt + \Delta$  and  $b = \frac{4\pi z}{\lambda} \sin \frac{\phi}{2}$ , since

$$\cos(a + b) + \cos(a - b) = 2 \cos a \cos b,$$

we have for the total electric intensity at  $P$ ,

$$E_p = E_{p1} + E_{p2} = 2A_\phi \cos b \cos(pt + \Delta).$$

This is a harmonic function, whose maximum occurs when  $\cos(pt + \Delta) = 1$ , so that its amplitude is

$$A_p = 2A_\phi \cos b. \quad (4)$$

We may now write the general principle that the energy or intensity of a wave is proportional to the square of its amplitude in the form,<sup>1</sup>

$$I = \beta A^2.$$

The intensity of the beam scattered to  $P$  is thus

$$I_p = 4\beta A_\phi^2 \cos^2 b. \quad (5)$$

In order to obtain the average value of this intensity for all possible orientations of the line  $e_1 O e_2$ , let us express  $I_p$  as a

<sup>1</sup> In the present case, where  $A$  is the amplitude of the electric vector and  $I$  is the energy in the wave per cm.<sup>2</sup> per second,  $I = c \frac{A^2}{8\pi}$ , whence  $\beta = c/8\pi$ ,  $c$  being the velocity of light.

function of  $\alpha$ . Referring again to Fig. 132, we notice that  $z = a \cos \alpha$ , where  $a$  is the distance  $Oe_1$ , whence

$$b = \frac{4\pi a}{\lambda} \sin \frac{\phi}{2} \cos \alpha,$$

or writing

$$k = \frac{4\pi a}{\lambda} \sin \frac{\phi}{2}, \quad (6)$$

$$b = k \cos \alpha.$$

Then

$$I_p = 4\beta A_\phi^2 \cos^2 (k \cos \alpha).$$

But the probability that  $\alpha$  will lie between  $\alpha$  and  $\alpha + d\alpha$  is  $2\pi \sin \alpha d\alpha / 4\pi$ , or  $\frac{1}{2} \sin \alpha d\alpha$ . The average value of  $I_p$  is thus

$$\begin{aligned} I_p &= \int_0^\pi 4\beta A_\phi^2 \cos^2 (k \cos \alpha) \cdot \frac{1}{2} \sin \alpha d\alpha \\ &= 2\beta A_\phi^2 \int_0^\pi \cos^2 (k \cos \alpha) \sin \alpha d\alpha \\ &= 2\beta A_\phi^2 \left( 1 + \frac{\sin 2k}{2k} \right), \end{aligned}$$

or substituting the value of  $A_\phi$ ,

$$I_p = \frac{2\beta A^2 e^4 \cos^2 \phi}{r^2 m^2 c^4} \left( 1 + \frac{\sin 2k}{2k} \right). \quad (7)$$

Since  $A$  is the amplitude of the component of the electric vector of the primary beam lying in the plane  $XOP$ , it follows from our definition of  $\beta$  that the intensity of this component is  $I_{\pi} = \beta A^2$ , whence equation (2-26) becomes

$$I_p = 2 \frac{I_{\pi} e^4 \cos^2 \phi}{r^2 m^2 c^4} \left( 1 + \frac{\sin 2k}{2k} \right). \quad (8)$$

If the component of the primary beam had been considered whose electric vector is perpendicular to the plane  $XOP$ , equation (1) would have been modified only by the omission of the factor  $\cos \phi$ , since the scattered beam would always be

at right angles with the electron's acceleration. The analysis for this component would have been otherwise the same, leading to an intensity of the scattered beam at  $P$ , corresponding to expression (8),

$$I_p' = 2 \frac{I_1 e^4}{r^2 m^2 c^4} \left( 1 + \frac{\sin 2k}{2k} \right).$$

Thus the intensity at  $P$  due to an unpolarized primary ray is

$$I_\phi = \frac{1}{2}(\bar{I}_p + \bar{I}_p') = \frac{I e^4 (1 + \cos^2 \phi)}{r^2 m^2 c^4} \left( 1 + \frac{\sin 2k}{2k} \right) \quad (9)$$

Since the intensity of the ray scattered by a single independent electron is (3.04),

$$I_s = \frac{I e^4 (1 + \cos^2 \phi)}{2r^2 m^2 c^4},$$

this result may be written,

$$I_\phi = 2I_s \left( 1 + \frac{\sin x}{x} \right), \quad (10)$$

where

$$x = 2k = \frac{8\pi a}{\lambda} \sin \frac{\phi}{2} = \frac{4\pi s}{\lambda} \sin \frac{\phi}{2} \quad (11)$$

$s$  being the distance between the two electrons. Equations (10) and (11) are quoted in the text as equations (3.10) and (3.11).

## APPENDIX V

### THE WAVE-LENGTH OF GAMMA RAYS FROM RADIUM C

#### 1. *Crystal Method*

The  $\gamma$ -rays from radioactive elements are distributed over a wide range of wave-lengths. Experiments by Rutherford and Andrade,<sup>1</sup> using reflection from a crystal of rock-salt, revealed spectrum lines from  $\lambda = 1.365\text{A}$  to  $\lambda = .070\text{A}$  from a mixture of RaB and RaC, and Kovarik<sup>2</sup> using a counting chamber to detect the reflected rays, has observed  $\gamma$ -ray lines from RaC as short as  $.028\text{A}$ . For still shorter wave-lengths the intensity of reflection becomes too low to make measurements.

#### 2. *From Magnetic Beta Ray Spectra*

From the magnetic spectra of the  $\beta$ -rays from the radioactive elements, Ellis,<sup>3</sup> de Broglie<sup>4</sup> and Thibaud<sup>5</sup> have estimated the wave-length of  $\gamma$ -rays. For this purpose Einstein's photoelectric equation,  $T = h\nu - W_p$ , is assumed to hold, where  $T$  is the kinetic energy of the  $\beta$ -ray,  $\nu$  the frequency of the  $\gamma$ -rays, and  $w_p$  the energy required to remove the electron which forms the  $\beta$ -ray from its parent atom (cf. Chapter VIII). The wave-lengths thus calculated for RaC vary from  $0.209\text{A}$  to  $0.00557\text{A}$ .

<sup>1</sup> E. Rutherford and E. N. C. Andrade, *Phil. Mag.* **27**, 854; **28**, 263 (1914).

<sup>2</sup> A. F. Kovarik, *Phys. Rev.* **19**, 433 (1922).

<sup>3</sup> C. D. Ellis and H. W. B. Skinner, *Proc. Roy. Soc.* **105**, 60 (1924); C. D. Ellis, *Proc. Roy. Soc.* **101**, 1 (1922).

<sup>4</sup> M. de Broglie and J. Cabrera, *Comptes Rendus*, **176**, 295 (1923).

<sup>5</sup> J. Thibaud, *Comptes Rendus*, **178**, 1706 (1923); **179**, 165 (1924).

Ellis gives the following table of short  $\gamma$ -ray wave-lengths from RaC determined by this method: <sup>1</sup>

TABLE I  
 $\gamma$ -RAYS OF RaC

$\lambda$ (A.U.)	Intensity	(A.U.)	Intensity
.0453	4	.01095	13
.0375	2	.00991	7
.0320	6	.00867	16
.0290	3	.00695	8
.02023	30	.00557	3
.01315	7		

Weighting the different lines according to their estimated intensity we thus find for the mean wave-length,

$$\lambda_{\text{eff.}} = 0.0167A.$$

### 3. From Absorption Measurements

Of the methods for estimating the "effective wave-length" of the  $\gamma$ -rays from RaC, perhaps that depending upon absorption is the most reliable. This method consists in measuring the absorption coefficient in an element of high and an element of low atomic weight, such as lead and aluminium.<sup>2</sup> We may write the empirical formula (6-04) for the absorption per atom as

$$\mu_a = KZ^4\lambda^3 + kZ, \quad (1)$$

where the first term represents true absorption, and the second term that spent in the scattering process. If instead of the absorption per atom we consider the absorption per electron, we have

$$\mu_e = \frac{\mu_a}{Z} = KZ^3\lambda^3 + k. \quad (2)$$

Since the wave-length of  $\gamma$ -rays is less than the critical  $K$  absorption wave-length, the constants  $K$  and  $k$  are the same for

<sup>1</sup> C. D. Ellis, Proc. Camb. Phil. Soc. 22, 374 (1924).

<sup>2</sup> A. H. Compton, Washington University Studies, 8, 126 (1921); N. Ahmad, Proc. Roy. Soc. (1925).

all absorbing elements. An approximate calculation shows that for  $\gamma$ -rays  $KZ^3\lambda^3$  is negligible for a light element such as aluminium. Thus if  $\mu_{ePb}$  is the absorption per electron for lead and  $\mu_{eAl}$  that for aluminium, we have,

$$\mu_{ePb} - \mu_{eAl} = KZ_{Pb}^3\lambda^3,$$

or

$$\lambda = \{(\mu_{ePb} - \mu_{eAl})/KZ_{Pb}^3\}^{1/3}. \quad (3)$$

Taking  $K = 2.24 \times 10^{-2}$  (Richtmyer, cf. p. 189),  $Z_{Pb} = 82$ , and taking  $\mu_{ePb} = 2.80 \times 10^{-25}$  and  $\mu_{eAl} = 2.00 \times 10^{-25}$  (Table (6.3)), we thus find

$$\lambda_{eff.} = .0186A.$$

It will be seen that the reliability of this method depends upon the correctness of the assumption that the true absorption varies as  $\lambda^3$ . In addition to the experimental evidence summarized in Chapter VI, the theories of de Broglie and Kramers (Chapter XII) predict such variation for all wave-lengths.

#### 4. *From Diffraction of Gamma Rays by Atoms*

This method, described in Chapter III, depends upon the interference between the rays scattered by the electrons grouped close together in a heavy atom. Using lead as this heavy atom, we have found above (loc. cit.),

$$\lambda_{eff.} = 0.025A.$$

Since the rays of greater wave-length are more subject to interference effects than those of shorter wave-length, this "effective" wave-length should be somewhat longer than the center of gravity of the spectral energy distribution curve.

#### 5. *From the Wave-length of Scattered Gamma Rays*

The quantum formula,  $\delta\lambda = .0242 (1 - \cos \phi)$  (eq. (9.04)) for the change of wave-length of X-rays due to scattering has been so completely verified for ordinary X-ray wave-lengths that we can apply it to the  $\gamma$ -rays with considerable confidence. When  $\phi = 135^\circ$ , the scattered rays are increased in wave-length by .0413A, and it is consequently possible to

calculate the wave-length from the absorption coefficient of these scattered rays with a much shorter extrapolation than is necessary for the primary  $\gamma$ -rays.

From Table (6-4) we have for the rays scattered at 135 degrees,  $\mu_{eAl} = 2.4 \times 10^{-25}$  and  $\mu_{ePb} = 21 \times 10^{-25}$ . It follows from equation (3) that  $\lambda_{\text{eff.}}$  for 135 degrees is .057A, whence the effective wave-length of the primary rays is

$$\lambda_{\text{eff.}} = .016A.$$

### 6. From the Intensity of Scattered $\gamma$ -rays

Various forms of the quantum theory of X-ray scattering give different formulas for the absolute intensity of the scattered rays, and at present we are not in a position to select the correct formula. All of these theories predict, however, approximately the same ratio of true absorption to total absorption due to scattering (cf. Chapter IX). By equation (9.50) and (9.39), the ratio of the true absorption to the total absorption due to scattering is

$$\frac{\sigma_a}{\sigma} = \frac{\alpha}{1 + 2\alpha}. \quad (5)$$

Owen, Fleming and Fage<sup>1</sup> have measured this ratio for  $\gamma$ -rays filtered through 2.3 cm. of lead and absorbed in aluminium as 0.370. It follows that  $\alpha = 1.42$ , whence

$$\lambda_{\text{eff.}} = .0171A.$$

TABLE II  
EFFECTIVE WAVE-LENGTH OF THE HARD  $\gamma$ -RAYS FROM RaC  
By the More Reliable Methods

$\lambda$ (A.U.)	Method
0.0167	2. $\beta$ -ray spectra
0.0186	3. Absorption coefficient
0.016	5. Wave-length of scattered $\gamma$ -rays
0.0171	6. Ratio of true to total absorption
0.0171	Mean

<sup>1</sup> E. A. Owen, N. Fleming and W. E. Fage, Proc. Phys. Soc. 36, 365 (1924).

## APPENDIX VI

### CALCULATION OF THE CHANGE OF WAVE-LENGTH AND THE ENERGY OF RECOIL

We have from the text (eqs. (9.01), (9.02), and (9.03)),

$$h\nu = h\nu' + mc^2 \left( \frac{1}{\sqrt{1 - \beta^2}} - 1 \right), \quad (1)$$

$$\frac{h\nu}{c} = \frac{h\nu'}{c} \cos \phi + \frac{m\beta c}{\sqrt{1 - \beta^2}} \cos \theta, \quad (2)$$

$$0 = \frac{h\nu'}{c} \sin \phi + \frac{m\beta c}{\sqrt{1 - \beta^2}} \sin \theta. \quad (3)$$

Let us write the following abbreviations:

$$\alpha = h\nu/mc^2 \quad = \text{momentum of primary quantum}/mc,$$

$$\alpha' = h\nu'/mc^2 \quad = \text{momentum of scattered quantum}/mc,$$

$$b = \beta/\sqrt{1 - \beta^2} = \text{momentum of electron}/mc, \text{ whence}$$

$$1/\sqrt{1 - \beta^2} = \sqrt{1 + b^2}.$$

$$l_1 = \cos \phi, \quad m_1 = \sin \phi, \quad l_2 = \cos \theta, \quad m_2 = \sin \theta.$$

These equations then become,

$$\alpha = \alpha' + \sqrt{1 + b^2} - 1 \quad (4)$$

$$\alpha = \alpha'l_1 + bl_2, \quad (5)$$

$$0 = \alpha'm_1 + bm_2. \quad (6)$$

From equation (5),

$$b^2 l_2^2 = \alpha^2 - 2\alpha\alpha'l_1 + \alpha'^2 l_1^2,$$

and from (6),

$$b^2 m_2^2 = \alpha'^2 m_1^2.$$

Adding, and noting that

$$\begin{aligned} l^2 + m^2 &= 1, \\ b^2 &= \alpha^2 - 2\alpha\alpha'l_1 + \alpha'^2. \end{aligned} \quad (7)$$

But from equation (4),

$$b^2 = \alpha^2 - 2\alpha\alpha' + \alpha'^2 + 2\alpha - 2\alpha'.$$

Subtracting this from equation (7),

$$\begin{aligned} 0 &= 2\alpha\alpha'(1 - l_1) - 2\alpha + 2\alpha', \\ 0 &= \alpha(1 - l_1) - \left(\frac{\alpha}{\alpha'} - 1\right), \\ \frac{\alpha}{\alpha'} - 1 &= \alpha(1 - l_1). \end{aligned} \quad (8)$$

This means, since  $\alpha = h/mc\lambda$ ,

$$\left. \begin{aligned} \lambda' - \lambda &= \frac{h}{mc}(1 - \cos \phi) \\ \delta\lambda &= \gamma \text{ vers } \phi. \end{aligned} \right\} \quad (9.04)$$

or

From equation (8)

$$\alpha' = \alpha / \{1 + \alpha(1 - l_1)\}, \quad (9)$$

and by 4,

$$\begin{aligned} (\sqrt{1 - b^2} - 1) &= \alpha - \alpha / \{1 + \alpha(1 - l_1)\} \\ &= \frac{\alpha^2(1 - l_1)}{1 + \alpha(1 - l_1)}. \end{aligned}$$

Thus

$$E_{\text{kin.}} = mc^2(\sqrt{1 + b^2} - 1) = h\nu \frac{\alpha \text{ vers } \phi}{1 + \alpha \text{ vers } \phi}. \quad (9.05)$$

From equations (5) and (6) we see that

$$\frac{l_2}{m_2} = -\frac{\alpha - \alpha'l_1}{\alpha'm_1} = -\frac{1}{m_1} \left( \frac{\alpha}{\alpha'} - \frac{l_1}{1} \right),$$

which, using equation (9), becomes

$$\begin{aligned}\frac{l_2}{m_2} &= -\frac{1}{m_1}\{1 + \alpha(1 - l_1) - l_1\} \\ &= -(1 + \alpha)\frac{1 - l_1}{m_1},\end{aligned}$$

or

$$\cot \theta = -(1 + \alpha)\frac{1 - \cos \phi}{\sin \phi}.$$

Thus

$$\left. \begin{aligned}\cot \theta &= -(1 + \alpha) \tan \frac{1}{2} \phi, \\ \cot \frac{1}{2} \phi &= -(1 + \alpha) \tan \theta.\end{aligned}\right\} \quad (9.06)$$

Combining (9-5) and (9-6) we get

$$E_{\text{kin}} = h\nu - \frac{2\alpha \cos^2 \theta}{(1 + \alpha)^2 - \alpha^2 \cos^2 \theta} \quad (9.05)$$

# APPENDIX VII

## WAVE-LENGTHS OF X-RAY SPECTRUM LINES

Expressed in Ångströms, on the basis of  $D_{\text{CaCO}_3} = 3.0904\text{Å}$ .

### I. LINES OF THE K SERIES

Element	$\alpha_2$	$\alpha_1$	$\beta_2$	$\beta_1$	$\gamma_1$	$\gamma_2$	Authority
9 F	18.37			absent			1
11 Na	11.8836			11.591			2
12 Mg	9.86775			9.5345			2
13 Al	8.31940			7.9405			2
14 Si	7.10917			6.7393			2
15 P	6.14171			5.7890			2
16 S	5.36375	5.36090		5.0213			2
17 Cl	4.72136	4.71821		4.3946			2
19 K	3.73706	3.73368		3.44680			2
20 Ca	3.35495	3.35169		3.08343			2
21 Sc	3.02840	3.02503		2.77394			2
22 Ti	2.74681	2.74317		2.50898	2.4937		2
23 Va	2.50213	2.49835		2.27972	2.2046		2
24 Cr	2.28895	2.28484		2.08045	2.0670		2
25 Mn	.....	2.09732		1.90591	1.8932		2
26 Fe	1.93651	1.93230		1.75272	1.7406		2
27 Co	1.78956	1.78528		1.61713	1.6054		2
28 Ni	1.65854	1.65461		1.49703	1.4854		2
29 Cu	1.54116	1.53730		1.38933	1.3780		2
30 Zn	1.43587	1.43206		1.29260	1.28097		3
31 Ga	1.34161	1.33785		1.20591	.....		4
32 Ge	1.25521	1.25130		1.12671	1.11463		3
33 As	1.17741	1.17344		1.05518	1.04290		3
34 Se	1.10642	1.10241		.99027	.99792		3
35 Br	1.04160	1.03756		.93085	.91827		3
37 Rb	.92772	.92360		.82703	.81484		3
38 Sr	.87754	.87360		.78151	.76917		3
39 Y	.83118	.82700		.73932	.72663		3
40 Zr	.78850	.78429		.70048	.68835		3
41 Nb	.74882	.74457		.66449	.65255		3
42 Mo	.71208	.70780	.63163	.63124	.61969	.61825	3
	.712078	.707768	.631571	.631009	.619737		8
44 Ru	.64015	.64181		.57143	.56048		3
45 Rh	.61637	.61201		.54470	.53313		3
46 Pd	.58858	.58419	.52010	.51972	.50963	.50790	3
47 Ag	.56264	.55821	.49668	.49630	.48607		3
48 Cd	.53829	.53386	.47463	.47428	.46438		3
49 In	.51546	.51103	.45410	.45373	.44409		3
50 Sn	.49396	.48948	.43476	.43439	.42485		3
51 Sb	.47386	.46933		.41624	.40711		3
52 Te	.45491	.45037		.39924	.39035		3
53 I	.43703	.43249		.38341	.37483		3
55 Cs	.402	.398		.352	.....		5
56 Ba	.393	.388		.343	.....		5
57 La	.376	.372		.329	.....		5
58 Ce	.360	.355		.314	.....		5
59 Pr	.347	.342		.301	.....		5
60 Nd	.335	.330		.292	.....		5
73 Ta	.21973	.21488		.18991	.18452		6
74 W	.21345	.20862		.18422	.17898		6
76 Os	.20131	.19645		.17361	.16875		6
77 Ir	.19550	.19065		.16850	.16376		6
78 Pt	.19004	.18523		.16370	.15887		6
79 Au	.18483	.17996		.15902	.15426		6
81 Tl	.17466	.16980		.15011	.14539		6
82 Pb	.17004	.16516		.14606	.14125		6
83 Bi	.16525	.16041		.14205	.....		6
	.16573	.16091		.14220	.13621		7
92 U	.13095	.12640		.11187	.10842		7

In addition, there are groups of faint lines associated with the *K* series for elements of lower atomic number than 30 (see Siegbahn<sup>2</sup>).

2. THE MORE PROMINENT LINES OF THE *L* SERIES

Element	$\alpha_2$	$\alpha_1$	$\beta_1$	$\beta_2$	$\gamma_1$	Authority
24 Cr	21.69		21.35	.....	.....	I
25 Mn	19.48		19.17	.....	.....	I
26 Fe	17.60		17.27	.....	.....	I
29 Cu	13.309		.....	.....	.....	2
30 Zn	12.222		11.951	.....	.....	2
32 Ge	10.413		.....	.....	.....	2
33 As	9.6503		9.3940	.....	.....	2
34 Se	8.9706		8.7172	.....	.....	2
35 Br	8.3566		8.1076	.....	.....	2
37 Rb	7.3027		7.0604	.....	.....	2
38 Sr	6.8478		6.6092	.....	.....	2
39 Y	6.4349		6.1984	.....	.....	2
40 Zr	6.0559		5.8228	5.5734	5.3730	2
41 Nb	5.717	5.7113	5.4796	5.2253	5.0241	2
42 Mo	5.400	5.3943	5.1658	4.9092	4.7111	2
44 Ru	4.84367	4.83567	4.61100	4.3619	4.17282	2
45 Rh	4.59556	4.58778	4.36400	4.1221	3.9357	2
46 Pd	4.36660	4.35850	4.13730	3.9007	3.71636	2
47 Ag	4.15382	4.14564	3.92664	3.69383	3.51485	2
48 Cd	3.95636	3.94782	3.73008	3.5064	3.32800	2
49 In	3.77242	3.76367	3.54783	3.3312	3.15529	2
50 Sn	3.60108	3.59218	3.37792	3.1679	2.99493	2
51 Sb	3.44075	3.43177	3.21836	3.0166	2.84507	2
52 Te	3.29100	3.28199	3.06997	2.8761	2.70647	2
53 I	3.15087	3.14166	2.93093	2.74608	2.57748	2
55 Cs	2.89560	2.88610	2.67784	2.5064	2.34252	2
56 Ba	2.77904	2.76064	2.56224	2.3993	2.23660	2
57 La	2.66893	2.65968	2.45330	2.2980	2.13720	2
58 Ce	2.56511	2.55600	2.35100	2.2041	2.04433	2
59 Pr	2.46763	2.45770	2.25390	2.1148	1.95681	2
60 Nd	2.37563	2.36531	2.16221	2.0314	1.87383	2
62 Sm	2.20568	2.19501	1.99357	1.8781	1.72309	2
63 Eu	2.12733	2.11633	1.91631	1.8082	1.6543	2
64 Gd	2.05262	2.04193	1.84246	1.7419	1.58863	2
65 Tb	1.98231	1.97149	1.77268	1.6790	1.5266	2
66 Dy	1.91564	1.90460	1.70658	1.6198	1.4697	2
67 Ho	1.85206	1.84098	1.64350	1.5637	1.4142	2
68 Er	1.79140	1.78040	1.58344	1.5106	1.3623	2
69 Tm	1.7339	1.7228	1.5268	1.4602	1.3127	2
70 Yb	1.6789	1.66779	1.4725	1.4128	1.2648	2
71 Lu	1.62636	1.61551	1.4207	1.3672	1.2203	2
72 Hf	1.57704	1.56607	1.3711	1.3235	1.1765	2
73 Ta	1.5294	1.51825	1.32354	1.2810	1.13471	2
74 W	1.48452	1.47348	1.27917	1.24191	1.09553	2
76 Os	1.3982	1.38816	1.19459	1.16838	1.02247	2
77 Ir	1.35939	1.34834	1.15495	1.13287	0.98841	2
78 Pt	1.32121	1.31008	1.11722	1.09950	0.95545	2
79 Au	1.28489	1.27355	1.08093	1.06775	0.92437	2
80 Hg	1.2497	1.2385	1.0458	.....	8935	2
81 Tl	1.21603	1.20471	1.01266	1.00786	0.86529	2
82 Pb	1.18352	1.17202	0.97990	0.97990	0.83708	2
83 Bi	1.1533	1.14115	0.94930	0.95293	0.81065	2
90 Th	0.96524	0.95342	0.76259	0.79108	0.65103	2
92 U	0.92014	0.90833	0.71807	0.75268	0.61283	2

3. COMPLETE L SPECTRUM OF Mo, Pr AND W<sup>2</sup>

Element	$\alpha_1$	$\alpha_2$	$\alpha_3$	$\eta$	$\beta_4$	$\beta_8$
42 Mo	.....	5.400	5.3943	5.3721	5.835	5.0358
59 Pr	2.7781	2.46763	2.45770	.....	2.507	2.2501
74 W	1.67505	1.48452	1.47348	.....	1.4177	1.29874
	$\beta_1$	$\beta_3$	$\beta_{14}$	$\beta_2$	$\beta_{11}$	$\beta_{12}$
42 Mo	5.1658	5.0002	.....	4.9092	4.8597	4.8417
59 Pr	2.25390	2.2124	2.1220	2.1148	.....	.....
74 W	1.27917	1.26000	.....	1.24191	I 2354	.....
	$\beta_9$	$\beta_8$	$\beta_7$	$\beta_5$	$\gamma_5$	$\gamma_9$
42 Mo	.....	.....	.....	.....	4.8190	.....
59 Pr	2.0958	.....	2.0874	.....	2.0161	1.9622
74 W	1.2021	1.2354	1.2208	1.2125	1.1292	.....
	$\gamma_6$	$\gamma_7$	$\gamma_8$	$\gamma_{10}$	$\gamma_2$	$\gamma_3$
42 Mo	.....	.....	.....	.....	4.3613	.....
59 Pr	.....	1.9422	1.9322	1.8811	1.8750	I 8699
74 W	1.0720	.....	1.079	.....	1.06584	I 05965
						$\gamma_4$
						.....
						I 8153
						I 02647

## 4. THE MORE PROMINENT LINES OF THE M SERIES

Element	$\alpha_1$	$\alpha''$	$\alpha'$	$\beta$	$\beta''$	$\gamma$	$\gamma'$	Authority
66 Dy	.....	.....	.....	9.323	.....	.....	.....	2
67 Ho	9.150	.....	.....	8.943	8.919	.....	.....	2
68 Er	8.783	.....	.....	8.573	.....	.....	.....	2
70 Yb	8.125	8.011	8.090	7.891	7.870	.....	.....	2
71 Lu	7.820	7.803	7.787	7.582	7.560	.....	.....	2
72 Hf	7.521	.....	.....	7.286	.....	.....	.....	II
73 Ta	7.238	.....	.....	7.001	.....	6.301	.....	2
74 W	6.973	6.952	.....	6.745	6.726	6.085	6.066	2, 9, 10
76 Os	6.481	6.459	.....	6.250	6.233	5.672	5.652	2
77 Ir	6.250	6.223	.....	6.030	6.011	5.484	.....	2
78 Pt	6.041	6.020	.....	5.820	5.797	5.303	.....	2
79 Au	5.831	5.812	.....	5.619	.....	5.131	.....	2
81 Tl	5.443	5.427	.....	5.233	5.210	4.806	4.798	2
82 Pb	5.273	5.250	5.242	5.065	5.042	4.666	.....	2
83 Bi	5.107	5.078	.....	4.804	4.875	4.513	4.497	2
90 Th	4.129	4.097	.....	3.931	3.925	3.657	3.645	2
92 U	3.901	3.885	.....	3.709	3.696	3.472	3.462	2

5 LINES OF THE N SERIES (HJALMAR<sup>2</sup>)

Element					
83 Bi	.....	.....	.....	.....	I3 208
90 Th	13.805	13.149	11.046	10.030	9.307
92 U	12.874	12.250	10.385	9.619	8.691

## REFERENCES:

- 1 R. Thoraues and M. Siegbahn, Ark. f. Mat. Ast. och Fysik **19**, 12 (1925).
- 2 M. Siegbahn, "The Spectroscopy of X-Rays" (1925).
- 3 A. Leide, C. R. **180**, 1203 (1925).
- 4 H. S. Uhler and C. D. Cooksey, Phys. Rev. **10**, 645 (1917).
- 5 J. Malmer, Dissertation, Lund (1915).
- 6 B. R. Stephensen and J. M. Cork, Phys. Rev. **27**, 138 (1926).
- 7 G. Rechou, C. R. **180**, 1107 (1925).
- 8 S. K. Allison and A. H. Armstrong, Phys. Rev. **26**, 701 (1925).
- 9 R. Thoraues, Z. f. Phys. **26**, 396 (1924).
- 10 R. V. Zumstein, Phys. Rev. **25**, 747 (1925).
- 11 D. Coster, Phil. Mag. **46**, 956 (1923).

## INDEX

- Absorption*, coefficients, 7, 177, 355  
 critical, 186, 190, 191  
 due to scattering, 194, 307  
 empirical formula for, 189  
 experimental test of classical theory,  
     204  
 long wave trains, 198  
 mass, 7, 8  
 tables of coefficients, 180-185  
 total, 175  
 true, 309
- Ahmad, N., 308
- Allen, S. J. M., 308
- Andrade, E. N. C., 389
- Atomic and electron constants*, 383
- Atomic number and Moseley's law*, 25
- Atoms*, distances apart in crystals, 92, 93,  
     116  
 distribution of electrons in, 79  
 regularity of grouping in liquids, 75-77
- Auger, P., 249
- Ayres, T., 306
- Babcock, G. D., 271
- Bache, A., 176
- Backhurst, I., 169
- Balmer's series*, 34
- Barkla, C. G., 13, 25, 35, 47, 62, 68, 81,  
     178, 186, 230, 261, 306
- Barlow, 91
- $\beta$  ray, excited by X-rays, 224  
 ionization by, 257  
 tracks, 4, 258
- Bearden, J. A., 132, 147, 167
- Beatty, R. T., 230
- Bohr, N., 29, 35, 239, 257, 278, 282, 315,  
     316, 343
- Bohr's theory*, 29-35, 315-317, 324
- Bothe, W., recoil electrons, 259, 273
- Bosanquet, C. H., 117, 135, 144, 147, 149,  
     153, 161, 165, 167
- Bowen, I. S., 342
- Bragg, W. H., 21, 115, 117, 118, 135, 137,  
     138, 144, 147, 149, 151, 153, 161,  
     165, 167, 169, 253
- Bragg, W. L., 20, 115, 117, 137, 138
- Bragg's formula*, 23, 96, 318  
 corrected for refraction, 212  
 derived by use of quanta, 317
- Brandes*, effect of X-rays on the retina, 1
- Bravais, 91
- Broglie, L. de, theory of absorption, 349
- Broglie, M. de, 172, 231, 253, 328, 389
- Breit, G., intensity of scattered radiation,  
     297, 304, 321
- Bubb, F. W., 236, 241, 357, 358
- Bubb's theory of distribution of photo-  
 electrons*, 246, 358
- Cabrera, J., 389
- Characteristic radiations*, 13, 26-27, 396-  
     398
- Clark, H., 74
- Coefficient*, absorption, 7, 177, 180-185,  
     355  
 scattering, 60
- Collins, E. H., 169
- Compton, A. H., 33, 67, 69, 70, 75, 81,  
     88, 133, 173, 262, 264, 265, 274,  
     275, 282, 298, 306, 390
- Compton, K. T., 173, 223
- Continuous spectrum*, 27  
 short-wave limit, 27  
 intensity and voltage, 28
- Coolidge tube*, 3
- Correspondence principle and scattered  
 energy*, 296
- Cosmic rays*, 57

- Coster, D., 343  
 Crowther, J. A., 188  
*Crystals*, analysis by powder method, 102  
   diffuse scattering by, 170  
   infinite, simple cubic, 318  
   lattices, 92, 93  
   Miller, indices, 94  
   perfect and irregular, 119, 126  
   reflection, 18-25, 95  
   reflecting power, 117  
   reflection and temperature, 169  
   reflection from very small crystals, 121  
   table of structure of the elements, 116  
  
*Damping and width of lines*, 54  
 Darwin, C. G., 74, 119, 139, 140, 142, 169, 212  
 Dauvillier, A., 188, 346  
 Davis, Bergen, 134, 142, 143, 214, 219  
 Debye, P., 74, 75, 76, 102, 169, 172, 297  
 DeFoe, O. K., 294  
 Dershem, E., 8  
*Diffraction of X-rays*, 16-25  
   by crystal, 18-25, 126-129, 318  
   by liquids, 75-77  
   by ruled grating, 17, 325  
   by slit, 16  
 Doan, R. L., 215  
 Dobronawow, N., 238  
*Doppler effect and scattering*, 264, 279  
 Dorn, E., 1  
*Doublets*, relativity, 337, 339  
   irregular, 340  
 Drude, P., 205  
 Duane, W., 36, 115, 151, 158, 161, 172, 188, 213, 223, 271, 317, 332, 337  
  
 Ehrenfest, P., 77, 161, 321  
 Einstein, A., 222  
*Electromagnetic energy*, 42  
*Electromagnetic field due to slow electron*, 39  
*Electromagnetic field due to accelerated electron*, 40  
*Electromagnetic radiation of energy*, 43  
*Electromagnetic theory*, 38-57, 365-380  
*Electrons and atomic constants*, 383  
  
*Electrons*, binding of, and scattered quanta, 285-295  
   complex, effect on scattering, 87  
   cooperation in scattering, 65  
   density in atomic layers, 152, 159  
   distribution in atoms, 79, 161, 165, 343  
   distribution and "structure factor," 148  
   free, and scattered quanta, 265-285  
   in Bohr orbits, and scattered quanta, 289  
   large, and scattering, 88  
   mass and velocity, 374  
   number per atom, 61  
   photo-electrons, 14, 230, 235-259  
   moving, radiation from, 38-50, 365-380  
   recoil, 227, 273, 393  
 Ellis, C. D., 231, 233, 253, 389  
*Energy levels*, 232  
 Epstein, P., 161, 321  
 Ewald, P., 110, 140, 212  
*Extinction in crystals*, 134, 135, 143, 146  
  
 Fage, E. W., 308, 313  
 Faxen, H., 169, 172  
 Fleming, N., 308, 313  
 Florance, D. C. H., 306  
*Flourescent rays*, 11, 12  
*Fourier series applied to a pulse*, 48  
*Fourier series*, electron distribution, 151  
 Fricke, H., 312, 337  
 Friedrich, W., 7  
   ray wave lengths, 233, 234, 389, 392  
  
*Gases*, ionization of, 4  
 Geiger, H., 225  
*General radiation*, form of energy curve, 27  
   polarization, 47  
   pulse, theory of production, 38-52  
   short-wave limit, 51  
 Glasser, O., 312  
 Glocker, R., 74  
*Gnomonic projection*, 110  
 Grant, 188  
*Grating*, crystal, 18-25, 327  
   ruled, 17, 325  
  
 Haga, 16, 47  
 Hagenow, C. T., 69

- Hallwachs, W., 237  
 Hatley, C. C., 37, 214  
 Hartree, D. R., 347  
 Havighurst, R. J., 147, 151, 161, 165  
 Herweg, J., 47  
 Hewlett, C. W., 61, 62, 66, 76, 172, 306, 308  
 Hjalmar, E., 213  
 Houstoun, R. A., 202  
 Hughes, A. L., 223  
 Hull, A. W., 102, 115  
 Hunt, F. L., 223
- Inertia and energy*, 376  
 Innes, P. D., 230  
*Intensity*, distribution about cathode stream, 46  
   Kramer's theory, 352  
   long wave trains, 53  
   scattered radiation, 296-314  
*Inter-atomic distances*, 75, 92, 93, 116  
*Ionization due to  $\beta$  rays*, 257  
*Ionization produced by X-rays*, 4  
*Irregular doublets*, 390
- J radiation*, 188, 261  
 James, B. W., 117, 135, 144, 147, 149, 153, 161, 167, 169, 171  
 Jauncey, G. E. M., 48, 169, 172, 288-295, 302-304  
*Jauncey's theory of scattering*, 288-295  
*Jauncey's formula for scattered intensity*, 302  
 Jeans, J. H., 221  
 Joffe, A., 238
- K radiation*, 26, 261, 333, 396  
 Kaye, G. W. C., 45  
 Keeson, W. H., 76  
*Kirchhoff's law and X-ray absorption*, 349  
 Kleeman, R. D., 237  
 Kohlrausch, K. W. F., 306  
 Kovarik, A. F., 389  
 Kramers, H. A., 239, 278, 282, 351, 352, 391  
*Kramer's theory of emission and absorption*, 349
- L radiation*, 26, 261, 333, 397  
 Lande, 74  
 Larsson, A., 37, 217  
 Laub, J., 188  
 Laue, M., 18, 90  
*Levels*, energy, 332  
*Lines*, characteristic, 13, 26-27, 396-398  
   width due to damping, 54  
*Liquids and X-ray diffraction*, 75-77  
 Löbe, W. W., 45  
 Lorentz, H. A., 205, 209  
*Lorentz transformation*, 365  
*Lyman series*, 34
- M radiation*, 333, 398  
*Magnesium*, crystal structure, 109  
*Magnesium oxide*, crystal structure, 113  
*Magnetisation and reflection*, 173  
*Mass absorption*, 7, 8, 180-185  
 Maizlish, I., 87  
 Maxwell, displacement currents, 38  
*Miller indices*, 94, 111  
 Millikan, R. A., 5, 223, 342  
*Molybdenum*, crystal structure, 107  
*Momentum of radiation*, 265  
 Moseley, H. G. J., 25, 35, 337, 343  
*Moseley's diagram*, 343  
*Moseley's law*, 25, 35, 337
- Nardroff, R. von, 37, 214, 220  
 Nernst, E., 222  
 Nuttall, J. M., 294
- Olmstead, P. S., 33  
 Olson, A. R., 8  
*Optical and X-ray doublets*, 342  
 Owen, E. A., 188, 194, 238, 308, 313  
*Owen's law*, 192, 254
- Partzsch, A., 237  
 Patterson, R. A., 213  
 Peirce, S. E., 178  
 Perrin, F., 249  
*Photo-electric effect*, 14  
   compound, 233  
   method of production, 238

- Photo-electrons*, 13  
 and quanta, 248  
 maximum emission angle, 246  
 number, 253  
 range in matter, 254  
 spatial distribution, 235, 246, 249  
 speed, 230
- Planck's constant*, 13, 90
- Planck's quantum hypothesis*, 221
- Pohl, R., 16
- Poincare, 221
- Polarization*, general radiation, 15, 47, 362  
 scattered radiation, 69
- Principle of correspondence*, 296
- Pulse theory*, 38-52, 195-198, 381-382  
 and absorption, 195  
 difficulties with, 50  
 efficiency of production of X-rays, 48  
 Fourier integral, 381  
 intensity of radiation, 43
- Quanta*, directed, and scattered X-rays,  
 281  
 directed, vs. spreading waves, 27, 35  
 energy of, 222, 265  
 "frequency," 321-323, 358  
 instantaneous action of, 287  
 momentum of, 265  
 scattered by free electrons, 264, 279
- Quantum theory*, origin of, 221
- Rabinov, I. I., 17
- Raman, C. V., 77
- Ramanathan, H. R., 77
- Rawlinson, W. F., 227
- Rayleigh, 221
- Read, H. S., 8
- Recoil electrons*, 227
- Reflection of X-rays*, 18-25  
 and magnetisation, 173  
 effect of temperature on, 169  
 from perfect crystals, 140  
 integrated, 118, 128  
 total, 18, 215
- Refraction of X-rays*, 35  
 and electron frequencies, 205, 206  
 by a prism, 217  
 by crystal wedge, 214
- Refraction of X-rays—Continued*  
 by total reflection, 217  
 deviation from Bragg's law, 211  
 significance of index less than unity, 210  
 table of indices, 218
- Regular and irregular doublets*, 334
- Relativity doublets*, 337, 339
- Richardson, O. W., 223, 230
- Richtmyer, F. K., 188, 194, 219, 391
- Robinson, H. R., 227, 232, 346
- Roentgen, W. C., 1, 21, 35, 217
- Rognley, O., 173
- Ross, P. A., 270, 272, 273, 293
- Rosseland, S., 257
- Rutherford, E., 29, 258, 389
- Sadler, C. A., 13, 25
- Scattered X-radiation*, 11, 12  
 absorption coefficient, 194, 307  
 and quanta, 260, 265  
 Breit's formula for intensity, 304  
 change of wave length in, 69, 261-272,  
 393  
 coefficient of, 60  
 Compton's formula for intensity, 300  
 conservation of energy, 266, 286  
 cooperation of electrons, 64, 384  
 Debye formula for intensity, 297  
 distribution of electrons in atoms and,  
 61, 79  
 Doppler effect, 264  
 early experiments on, 261  
 failure of wave theory, 83  
 from bound electrons, 84, 285  
 from complex electrons, 87  
 from electrons in Bohr orbits, 289  
 from groups of electrons, 79  
 hard, 62, 83  
 intensity and scattering angle, 66, 67  
 interference effects, 64, 72, 384  
 Jauncey's formula for intensity, 302  
 method of computing wave length  
 from, 80  
 Thomson theory, 58  
 unmodified line, 272
- Scheerer, P., 76, 102
- Schoenflies, 91
- Schoenke, 91

Schott, G. A., 74  
*Secondary rays*, 8  
*Selection rule*, 333  
 Sharp, H. M., 271  
 Shearer, G., 230  
 Shimizu, T., 188  
 Siegbahn, M., 26, 36, 37, 329, 346  
*Silicon*, crystal structure, 109  
 Simon, L., 231, 294  
 Slack, C. M., 219  
 Slater, J. C., 239, 278, 282  
 Smedt, J. de, 76  
*Space lattice*, 91-93, 116  
 Stark, J., 45  
 Stempel, W. M., 134, 142, 143  
 Stenström, W., 26, 217  
 Stoker, G., 38, 43  
 Stoner, E. C., 343, 345  
 Storch, H. H., 8  
 "Structure factor," 122, 137, 148  
 Stuhlman, O., 237  
 Summerfeld, A., 335, 336, 339, 341, 342

*Tables*, absorption coefficients, 180-185  
 atomic and electron constants, 383  
 centered cubic, 107  
 crystal structure of the elements, 116  
 crystals with large space lattice, 328  
 damping of electron by radiation, 55  
 grating space and temperature, 327  
 indices of refraction for X-rays, 218  
 lattice simple cubic, 95  
 lengths of Wilson tracks, 276  
 mass, scattering coefficients, 313  
 maximum emission angle for photo-electrons, 246  
 molecular distances in liquids, 77  
 number and type of Wilson tracks, 276  
 number of recoil electrons, 295  
 ray wave lengths, 234, 392  
 reflection and absorption by rock salt,

137

*Tables—Continued*

refractive index by deviations from  
 Bragg's law, 213  
 structure factor, 156  
 test of classical theory of absorption,  
 204  
 Thomson-Whiddington constant, 256  
 wave-lengths of spectrum lines, 396-398  
 Terrill, H. M., 255  
 Thibaud, J., 389  
*Thin target radiation*, 45  
 Thomson, J. J., 38, 58, 74, 254, 257  
*Thomson's pulse theory*, 38  
*Total reflection*, 18, 215  
 Ulrey, C. T., 27  
 Vegard, L., 47  
 Wagner, E., 46  
 Waller, L., 37, 169, 217  
 Walter, B., 16, 17, 217  
 Warburton, F. W., 194  
*Wave-length*, minimum set by damping, 56  
 of characteristic lines, 16-24, 396-398  
*Wave trains*, energy and intensity, 53  
 necessity for long, 52  
 number of waves in, 55  
 Webster, D. L., 35, 52, 54, 74, 186  
 Whiddington, R., 230, 255  
 White, M. P., 188  
 Williams, F. J., 188, 294  
 Wilson, C. T. R., 4, 225, 253, 255, 258,  
 273, 275  
*Wind*, 47  
 Woo, Y. H., 178, 269, 294, 298  
 Wyckoff, R. W. G., 110, 113, 115  
*X-ray spectra*, 328  
 classification, 330







