

UNIVERSAL  
LIBRARY

**OU\_148543**

UNIVERSAL  
LIBRARY

OSMANIA UNIVERSITY LIBRARY

Burkhardt, H.

Theory of Functions of a  
Complex variable.





# THEORY OF FUNCTIONS

## OF A COMPLEX VARIABLE

BY

DR. HEINRICH BURKHARDT

O. PROFESSOR, TECHNICAL SCHOOL, MUNICH

AUTHORIZED TRANSLATION FROM THE FOURTH GERMAN EDITION  
WITH THE ADDITION OF FIGURES AND EXERCISES

BY

S. E. RASOR, M.Sc.

PROFESSOR OF MATHEMATICS, THE OHIO STATE UNIVERSITY

REVISED

D. C. HEATH & CO., PUBLISHERS  
BOSTON            NEW YORK            CHICAGO

**COPYRIGHT, 1913, BY  
D. C. HEATH & Co.**

**2 F O**

## TRANSLATOR'S PREFACE

FOR a number of years there has been a feeling among many teachers of mathematics that students would accomplish more if they had an introductory treatise on the Theory of Functions of a Complex Variable written in English and adapted in other ways to the use of students beginning their graduate work. Professor Burkhardt's book *Einführung in die Theorie der analytischen Funktionen einer komplexen Veränderlichen* has seemed admirably suited to this purpose both in the matter of material and arrangement. The translation of this text into English was undertaken at the suggestion and encouragement of prominent American mathematicians, since there is no book in the English language treating the subject from the point of view adopted here.

The translation preserves the same arrangement of material as the original book, even to the numbering of sections and theorems. Footnotes not in the original text are always signed. All of the exercises, which include a number of additional figures and which follow various sections and each of the chapters, are added by the translator. It is hoped that they will prove of assistance not only in illustrating and fixing the ideas contained in the text but as well in stimulating the reader to independent attack and further study in larger treatises. It seemed best not to give the sources from which many of these exercises were obtained—some of them being original, some the results of courses with the late Professor Maschke of the

University of Chicago, some furnished by Professor Osgood of Harvard University, and others seeming by this time to have become common property.

In any case, the aim has been to place at the disposal of students such a book as will be of greater service in obtaining a knowledge of the fundamental principles underlying the theory of functions.

I wish to acknowledge my indebtedness and gratitude to Professor N. J. Lennes of the University of Montana for his interest and help in reading much of the manuscript; to Professor E. G. Bill and Dr. F. M. Morgan of Dartmouth College for reading the proof-sheets and making use of them in class-work; and especially to Professor J. W. Young of Dartmouth College for valuable counsel and criticism.

In the second edition, minor corrections have been made in the text and a few changes, rearrangements, and minor additions made in the lists of examples.

S. E. RASOR.

THE OHIO STATE UNIVERSITY,  
April, 1920.

## FROM THE PREFACE TO THE FIRST EDITION

NEARLY all\* of the numerous present German textbooks on the theory of functions treat the subject from a single point of view—either that of WEIERSTRASS or that of RIEMANN. More recent French and English textbooks (PICARD, FORSYTH, HARKNESS and MORLEY) have endeavored to close the gap between the two methods; in Germany, too, lectures and scientific works have gradually sought to unify the two theories. But we are yet in need of a book of moderate extent . . . suitable to introduce beginning students to both methods. I appreciated very much the need of such a book as I undertook to write . . . this introduction to the theory of functions. RIEMANN'S geometrical methods are given a prominent place throughout the book; but at the same time an attempt is made to obtain, under suitable limitations of the hypotheses, that rigor in the demonstrations which can no longer be dispensed with when once the methods of WEIERSTRASS are known.

The extended account of the theory of functions from RIEMANN'S standpoint is in reality a preparation for his theory of integrals of algebraic functions. This was entirely relevant while this theory was the only part of RIEMANN'S plans concerning the theory of functions which had been carried out. In the meantime the linear differential equations and the automorphic functions have come into prominence through the work of POINCARÉ and KLEIN. In an elementary book we must consider this most important change; the conception of the *fundamental region* must have a prominent place in such a book and must be fully explained in connection with the simplest examples, such as  $z^n$  and  $e^z$ . To make room for this I have omitted a part of the usual material, the first of which is the general analysis situs of the RIEMANN'S surface with a finite number of sheets.

\* A possible exception is HARNACK'S *Outlines of the Differential and Integral Calculus*; but this cannot be recommended to beginners.

The details in the arrangement of the material may be seen from the table of contents; however, we mention the following particulars.

In the *first* chapter, I have introduced the algebra of complex numbers as an algebra of number-pairs without giving a general theory of number systems of two (or more) units; I have rather assumed without discussion the hypotheses characteristic of the theory of "ordinary complex numbers."

The *second* chapter contains a detailed geometrical theory of the elementary rational functions of a complex variable and the conformal representations determined by them. The transition from the plane to the sphere by stereographic projection is also considered; it is used at various places in the following chapters. The chapter closes with a discussion of the symmetric invariants of four points as a function of their double ratio; this takes the place of an example (in itself unimportant) of a rational function of a more general character.

The *fourth* chapter gives the theory of single-valued functions of a complex argument essentially according to CAUCHY and RIEMANN. After deriving the properties of such functions in domains in which they are regular, a special discussion of the sine and the cosine and the exponential functions is added. Then follows the theory of isolated singular points in connection with LAURENT'S theorem; FOURIER'S series are studied at the same time. The discussion of MITTAG-LEFFLER'S theorem is limited to the simple case for which the degree of the additional polynomial does not become infinite. The chapter closes with the applications of this theorem to singly periodic functions.

In the *fifth* chapter, which treats of many-valued functions, I have ventured a change in the usual arrangement which may not meet with general approval: I have put the logarithm and the infinitely-sheeted RIEMANN'S surface accompanying it first and then used its properties in the investigation of even the simplest irrationalities. It is possible to do this without in any way making use of transcendental functions; but to be consistent we must then avoid the trigonometric form of a complex number, which is nothing else than introducing its logarithm, and prove the existence of the  $n$  roots of complex numbers by the fun-

damental theorem of algebra. This appeared to be too cumbersome for an elementary book. Moreover, the general theory of algebraic functions is entirely omitted from this chapter and in its place a detailed discussion of the simplest cases is given. At the close of the chapter the properties of the logarithm are used to obtain the representation of a transcendental integral function by means of an infinite product from the division into partial fractions of its logarithmic derivative.

I have named the *sixth* and last chapter "General Theory of Functions." The general conception of analytic continuation, the analytic function, the RIEMANN'S surface, the natural boundary, are first treated. Besides this the chapter contains a discussion of the principle of reflection.

Statements as to the authorities for the definitions and theorems are omitted. At particular places as they happen to occur in the text I have given references to the literature for such readers as wish to study any of the questions further; in this, original sources have not always been named but where possible just such references have been given as seem suitable for the beginner. . . .

ANSBACH, March 26, 1897.

---

## PREFACE TO THE SECOND EDITION

SINCE the first two and the last three chapters have met with general approval outside of the strict disciples of WEIERSTRASS, I have no occasion to make essential changes in these chapters. I have given the proof of CAUCHY'S fundamental theorem in the simple form made possible by the researches of PRINGSHEIM, GOURSAT, and MOORE; this necessitated a few other changes and rearrangements. Besides, I hope to have gained in clearness at a few places by minor additions.

On the contrary, the third chapter is entirely remodeled: elementary things are put in my algebraic analysis which has appeared in the meantime as part one of these lectures, while a few other theorems which were not in their place there but which are needed here now

viii      PREFACE TO THIRD AND FOURTH EDITIONS

appear with proofs. Since the idea of the double integral is no longer required in the proof of CAUCHY'S theorem, the space thus required is kept within moderate bounds. . . .

ZURICH, October 12, 1903.

---

PREFACE TO THE THIRD AND FOURTH EDITIONS

IN the third edition I have further added a few examples of conformal representation and in connection with them a discussion of the cyclometric functions of a complex argument. . . . In the fourth edition the theorem of MORERA (XIII, § 38) and the proof of the theorem of WEIERSTRASS (§ 50) based upon it are added, besides many improvements in details.

H. BURKHARDT.

MUNICH, May 11, 1912.

# CONTENTS

## CHAPTER I

### COMPLEX NUMBERS AND THEIR GEOMETRICAL REPRESENTATION

SECTION	PAGE
1. On the General Arithmetic of Real Numbers . . . . .	1
2. Introduction of Number-pairs ; their Addition and Subtraction	3
3. Multiplication of Number-pairs ; Number-pairs as Complex Numbers . . . . .	7
4. Geometrical Representation of Complex Numbers by the Points of the Plane . . . . .	12
5. Geometrical Representation of Addition and Subtraction of Complex Numbers . . . . .	16
6. Geometrical Representation of Multiplication of Complex Numbers . . . . .	18
7. Division of Complex Numbers . . . . .	20
Examples . . . . .	23

## CHAPTER II

### RATIONAL FUNCTIONS OF A COMPLEX VARIABLE AND THE CONFORMAL REPRESENTATIONS DETERMINED BY THEM

8. General Introduction ; the Function $z + a$ and the Parallel Translation . . . . .	28
9. The Function $az$ . . . . .	30
10. The Linear Integral Function and the General "Similarity" Transformation . . . . .	32
Examples . . . . .	37
11. The Function $1/z$ and the Transformation by Reciprocal Radii . . . . .	38
Examples . . . . .	43
12. Division by Zero ; Infinite Value of a Complex Variable . . . . .	45

SECTION	PAGE
13. Transition from the Plane to the Sphere by Stereographic Projection . . . . .	47
Examples . . . . .	53
14. The General Linear Fractional Function and the Circle Transformation . . . . .	54
Examples . . . . .	63
15. The Double Ratio Invariant under the Linear Transformation . . . . .	65
Examples . . . . .	73
16. Significance of the Linear Transformation on the Sphere; Collineations of Space corresponding to it . . . . .	77
17. The Function $z^2$ . . . . .	82
18. The Function $w = z^n$ , $n$ a Positive Integer . . . . .	87
Examples . . . . .	93
19. Rational Integral Functions . . . . .	98
Examples . . . . .	101
20. Rational Fractional Functions . . . . .	102
Examples . . . . .	104
21. Behavior of Rational Functions at Infinity . . . . .	104
21 <i>a</i> . The Function $w = \frac{1}{2}(z + z^{-1})$ . . . . .	106
22. A somewhat more complicated Example of an Automorphic Rational Function . . . . .	113
22 <i>a</i> . Example of a Rational Integral Function which is not Linear Automorphic . . . . .	119
Miscellaneous Examples . . . . .	125

### CHAPTER III

#### DEFINITIONS AND THEOREMS ON THE THEORY OF REAL VARIABLES AND THEIR FUNCTIONS

23. Sets of Points on a Straight Line . . . . .	127
Examples . . . . .	130
24. Application of the previous Theorems; Continuity on an Interval . . . . .	131
Examples . . . . .	135
25. Sets of Points in the Plane . . . . .	135
Examples . . . . .	142
26. Continuity of Functions of two Real Variables . . . . .	143

SECTION	PAGE
27. Derivatives . . . . .	148
28. Integration . . . . .	151
29. Curvilinear Integrals . . . . .	156
Miscellaneous Examples . . . . .	162

## CHAPTER IV

SINGLE-VALUED ANALYTIC FUNCTIONS OF A  
COMPLEX VARIABLE

30. Introduction . . . . .	167
30 <i>a</i> . Limits of Convergent Sequences of Complex Numbers . . . . .	168
31. Continuity of Rational Functions of a Complex Variable . . . . .	170
32. Derivative of a Rational Function of a Complex Argument . . . . .	174
33. Definition of Regular Functions of a Complex Argument . . . . .	178
Examples . . . . .	180
34. Conformal Representation . . . . .	182
Examples . . . . .	187
35. The Integral of a Regular Function of a Complex Argument . . . . .	188
36. CAUCHY'S THEOREM . . . . .	195
Examples . . . . .	197
37. Development of a Regular Function in a Power Series . . . . .	199
38. Properties of Complex Power Series . . . . .	201
39. TAYLOR'S, MACLAURIN'S DEVELOPMENT IN A POWER SERIES FOR Complex Variables . . . . .	206
Examples . . . . .	211
40. The Exponential Function and the Trigonometric Functions, Sine and Cosine . . . . .	216
Examples . . . . .	219
41. Periodicity of the Trigonometric and the Exponential Func- tions . . . . .	222
42. Conformal Representations Determined by Singly Periodic Functions . . . . .	224
43. Poles or Non-essential Singular Points . . . . .	227
44. Behavior of a Function of a Complex Argument at Infinity; the Fundamental Theorem of Algebra . . . . .	229
Examples . . . . .	235
45. CAUCHY'S THEOREM ON RESIDUES . . . . .	236
Examples . . . . .	239

SECTION	PAGE
46. The Theorem concerning the Number of Zeros and of Poles. Second Proof of the Fundamental Theorem of Algebra .	240
47. LAURENT'S Series . . . . .	247
Examples . . . . .	251
48. Behavior of a Regular Function in the Neighborhood of a Critical Point . . . . .	254
Examples . . . . .	256
49. FOURIER'S Series . . . . .	257
50. Sums of an Infinite Number of Regular Functions . . . . .	260
51. MITTAG-LEFFLER'S Theorem . . . . .	262
52. Decomposition of Singly Periodic Functions into Partial Fractions . . . . .	268
53. General Theorems concerning Singly Periodic Functions . . . . .	273
Miscellaneous Examples . . . . .	277

## CHAPTER V

### MANY-VALUED ANALYTIC FUNCTIONS OF A COMPLEX VARIABLE

54. Preliminary Investigation of the Change of Amplitude of a Continuously Changing Complex Quantity . . . . .	284
55. The RIEMANN'S Surface of the Amplitude . . . . .	289
56. The Logarithm . . . . .	294
Examples . . . . .	301
57. Conformal Representation Determined by the Logarithm . . . . .	304
Examples . . . . .	307
57 <i>a</i> . The Function $\tan^{-1} z$ . . . . .	311
58. The Square Root . . . . .	316
59. The RIEMANN'S Surface for the Square Root . . . . .	319
Examples . . . . .	324
60. Connectivity of this Surface . . . . .	328
60 <i>a</i> . Rational Functions of $z$ and $s = \sqrt{z}$ . . . . .	331
61. Application of CAUCHY'S Theorems to Functions which are single-valued on the RIEMANN'S Surface for $\sqrt{z}$ . . . . .	333
62. The Functions $\sqrt{(z-a)/(z-b)}$ and $\sqrt{(z-a)(z-\nu)}$ . . . . .	342
62 <i>a</i> . Rational Functions of $z$ and $\sigma = \sqrt{(z-a)(z-b)}$ . . . . .	344

SECTION	PAGE
62 <i>b</i> . Integrals of Rational Functions of $z$ and the Square Root of a Rational Integral Function of $z$ of the Second Degree . . . . .	351
62 <i>c</i> . The Function $z = w + i\sqrt{1 - w^2}$ . . . . .	355
62 <i>d</i> . The Function $\sin^{-1} w$ . . . . .	360
Examples . . . . .	364
63. The Function $\sqrt[n]{z}$ . . . . .	365
64. The Equation $s^2 = 1 - z^2$ . . . . .	368
Examples . . . . .	373
65. Transition from MITTAG-LEFFLER'S Division into Partial Fractions to WEIERSTRASS'S Development in a Product . . . . .	373
Miscellaneous Examples . . . . .	377

CHAPTER VI

GENERAL THEORY OF FUNCTIONS

66. The Principle of Analytic Continuation . . . . .	382
67. General Construction of the RIEMANN'S Surface determined by an Analytic Function . . . . .	385
68. Singular Points and Natural Boundaries of single-valued Functions . . . . .	389
Examples . . . . .	392
69. Singular Points and Natural Boundaries of many-valued Functions . . . . .	393
Examples . . . . .	397
70. Analytic Functions of Analytic Functions . . . . .	397
71. The Principle of Reflection . . . . .	399
72. Conformal Representation of a Triangle bounded by Straight Lines upon a Half-plane . . . . .	403
73. Generalization of the Principle of Reflection; Reflection on a Circle . . . . .	407
74. Conformal Representation of a Triangle bounded by Arcs of Circles upon the Half-plane . . . . .	409
Miscellaneous Examples . . . . .	414
INDEX . . . . .	422



# THEORY OF FUNCTIONS OF A COMPLEX VARIABLE

## CHAPTER I

### COMPLEX NUMBERS AND THEIR GEOMETRICAL REPRESENTATION

#### § 1. On the General Arithmetic of Real Numbers

ELEMENTARY ARITHMETIC is concerned with *integers* as its primary elements or objects. It shows how a third number can be found by simple *combinations* (addition, subtraction, multiplication, etc.) of any two numbers. It then derives *laws* by which the result of a certain series of combinations taken in order, for example  $a(b + c)$ , can also be found by another series of combinations, in this example by  $ab + ac$ . It finally makes use of these laws to determine how a quantity, which is to be combined in definite ways with other quantities, must be chosen, so that the result of these combinations shall be a value previously determined. The *proofs* of these laws and rules given in arithmetic are of two entirely different kinds (cf. A. A.\* § 1). In deducing the *fundamental* laws it makes use of the *real* significance of these objects (or numbers) and the operations to which they are to be subjected. Farther on this real significance is not considered, but manipulations are performed

\* In this way BURKHARDT'S *Algebraic Analysis* (2d edition) will be designated. It is the first part of Vol. I of BURKHARDT'S (1908) *Vorlesungen über Funktionentheorie*.

merely with the *symbols* for the objects and the operations on the basis of the doctrines of *formal logic* and those laws of arithmetic already deduced. This distinction is later of much importance. Originally the name *number* was given only to "*positive integers*." But the needs of geometry require that still other elements be regarded as numbers (negative, fractional, irrational) and as objects of the "*general arithmetic*." For these more general numbers combinatory operations are then defined. They are quite analogous to the operations with integers and receive the names applied to the latter operations. It is shown on the basis of the definitions that these operations with the more general numbers satisfy the fundamental laws mentioned above; hence it follows at once that the derived theorems are also true for them. The earlier proofs given only for positive integers are valid here word for word, since we no longer make use of the properties of the objects, but rely only upon the characteristics of the operations already established (A. A. § 1, § 9).

That it is *permissible* to introduce these more general numbers is based upon the *freedom of scientific thought* to choose its own objects; that it is *desirable* to introduce such numbers is shown by the *result*. The negative and fractional numbers represent relations between objects of daily experience in a broader sense than can be done by the exclusive use of positive integers. The irrational numbers arise from the desire to conceive, for scientific purposes, as absolutely exact those laws of space which enter only approximately into our experience. This desire cannot be satisfied by relations between integers alone.

In what follows, we shall suppose the negative and the fractional numbers to be introduced; on the contrary, the irrational number will be used at only a few places in the first two chapters.

## § 2. Introduction of Number-pairs ; their Addition and Subtraction

From the algebra of the *simple number* we pass next to an algebra of the *number-pair*—the so-called “double algebra.” It deduces a new number from two number-pairs and seeks the laws which underlie these combinations of number-pairs. The algebra of simple numbers finds its counterpart in the geometry of one-dimensional configurations in so far as it is possible to assign a definite number to each point of such configurations, a straight line for example, and one definite point to each number.\* We shall see that the double algebra is represented geometrically by the relations between the points of two-dimensional configurations or surfaces, and in particular upon the simplest of these, the plane and the sphere.

*What kind* of combinations of number-pairs we are to consider is arbitrary with us; whether the choice we make is adapted to our purposes is a question which can be answered in the affirmative when and only when results have been obtained which could not be obtained at all by other methods, or at least not so easily. But we have two requirements to govern our choice. We shall seek first those combinations which obey the same or nearly the same laws as those of simple numbers; and besides, we shall always keep in mind the relations to geometrical configurations. We shall not raise the question as to what might be the most general combinations which satisfy the first requirement and are also adapted to the second; but we shall begin with the definition of the combinations to be considered and then prove that they obey the above laws and show how they are represented geometrically. In this manner we follow the historical development. Number-pairs first appear in the form of “im-

\* Known as the CANTOR-DEDEKIND axiom; cf. PIERPONT, *The Theory of Functions of Real Variables*, Vol. I, p. 79, — S. E. R.

imaginary" numbers  $a + b\sqrt{-1}$  in the solution of algebraic equations of the second, third, and fourth degrees. Any hesitation on first using these "imaginary" numbers was easily overcome by being able to operate with them as with real numbers, even without justifying the process or without knowing what such an imaginary symbol in general signified. The following definitions are all given with the understanding that we operate with the imaginary number  $a + bi$  as with a real binomial and reduce higher powers of  $i$  to the first power by the relation  $i^2 + 1 = 0$ .

To operate with number-pairs it is necessary to define when two number-pairs are equal to each other. Definition:

I. *Two number-pairs*  $(a, b)$  *and*  $(c, d)$  *are equal to each other when and only when*

$$a = c \text{ and } b = d$$

(but not when  $a = d$  and  $b = c$ ). One equation between number-pairs therefore represents *two* equations between simple numbers. The concepts "larger" and "smaller" are not immediately applicable to number-pairs.

II. *From the two number-pairs*  $(a, b)$  *and*  $(c, d)$  *a third number-pair*

$$(a + c, b + d)$$

*can be formed in the simplest manner. A name and a symbol are needed for this operation. We shall not introduce new ones, but we shall borrow the name* *addition* *with its symbol*  $+$  *from the algebra of simple numbers. Accordingly the third number-pair is called the sum of the other two and is written:*

$$(I) \quad (a, b) + (c, d) = (a + c, b + d).$$

A new meaning is thus attached to these terms and symbols (addition, sum,  $+$ ,  $=$ ).

This combination of number-pairs is a definite operation,

*possible* and *unique* in every case. Moreover, this operation obeys the *commutative law* (A. A. IV, § 2):

$$(2) \quad (a, b) + (c, d) = (c, d) + (a, b);$$

and the *associative law* (A. A. III, § 2):

$$(3) \quad [(a, b) + (c, d)] + (e, f) = (a, b) + [(c, d) + (e, f)].$$

The first of these laws is proved by applying definition (II) to the operations indicated by each side of equation (2). The resulting number-pairs  $(a + c, b + d)$  and  $(c + a, d + b)$  are equal to each other according to definition (I), since  $a + c = c + a$  and  $b + d = d + b$  according to the commutative law for the addition of simple numbers. Equation (3) is proved in a similar manner.

The further theorems in elementary algebra about the rearrangement of the terms in a sum of three or more summands, can be proved by purely logical deduction from the commutative and associative laws without returning to the fundamental meaning of the operation of addition. It therefore follows that these extended theorems are valid for the operations with number-pairs just as for ordinary numbers (cf. the general remarks of § 1). Hence we may state the following general theorem of which equations (2) and (3) are special cases:

III. *In a sum of any number of number-pairs, the separate summands may be combined into a smaller number of other summands by an arbitrary selection and arrangement.*

We define further:

IV. *The number-pair  $(-a, -b)$  is called the opposite of the number-pair  $(a, b)$ .*

V. *The difference of two number-pairs is that number-pair which, when added to the subtrahend, gives the minuend.*

From this definition, the definition of sum (II), and the properties of addition and subtraction of simple numbers we obtain

*Theorem VI*, which is expressed by the equation :

$$(4) \quad (a, b) - (c, d) = (a - c, b - d);$$

also *Theorem VII*: *Subtraction of a number-pair is the same as addition of the opposite number-pair, and hence is a definite operation, possible and unique in every case.*

In elementary algebra the sum of ( $m$ ) (a positive integer) equal summands  $a$

$$a + a + a + \cdots + a + a$$

is called "the product of the number  $a$  by the positive integer  $m$ ." This definition has a definite meaning in consequence of *Theorem III* when applied to number-pairs; we say :

VIII. *The product of an integer  $m$  and a number-pair  $(a, b)$  is the sum of  $m$  equal number-pairs  $(a, b)$ .*

If we form this sum according to definition II and *Theorem III* we obtain a

*Theorem IX*, which is expressed by the equation :

$$(5) \quad m(a, b) = (ma, mb).$$

X. *In case  $m$  is a negative number, equation (5) is the definition of the product of  $m$  and the number-pair  $(a, b)$ .*

XI. *Division of a number-pair by an integer is defined as the inverse of multiplication.* Therefore, in consequence of equation (5):

$$(6) \quad \frac{(a, b)}{m} = \left( \frac{a}{m}, \frac{b}{m} \right).$$

XII. *Multiplication of a number-pair by a fraction* is defined as, "Multiplication by the numerator and division by the denominator" (A. A. § 15); and thus, from the equations (5) and (6), it follows that :

$$(7) \quad \frac{m}{n}(a, b) = \left( \frac{m}{n}a, \frac{m}{n}b \right).$$

XIII. *On the basis of the definitions II and XII, every number-pair can be represented in the form*

$$(8) \quad (a, b) = ae_1 + be_2$$

*as the algebraic sum of multiples of the two special number-pairs :*

$$e_1 = (1, 0),$$

$$e_2 = (0, 1),$$

*which are accordingly named UNITS.*

### § 3. Multiplication of Number-pairs ; Number-pairs as Complex Numbers

In elementary arithmetic *multiplication* is considered, after addition, as a second kind of combination of two numbers to produce a third number. Among the properties characteristic of this operation are the *commutative* law (A. A. III, § 4) expressed by the equality

$$(1) \quad ab = ba,$$

and its *distributive* relation with respect to addition (A. A. VI, § 4) expressed by the equality

$$(2) \quad a(b+c) = ab + ac.$$

We now inquire whether there exists also a combination of number-pairs which obeys both of these laws, that is, which is in itself commutative and which obeys the distributive law for addition of number-pairs stated in § 2. If such a combination exists, we name it *multiplication* and designate it by juxtaposition of the factors, with or without the point to connect them.

In accordance with the representation of number-pairs given by equation (8), § 2 and in accordance with the requirements of the commutative and the associative laws, the result of the

multiplication of any two number-pairs is determined when we have determined the product of the two units each by itself and each by the other (the result being, of course, a number-pair). We shall not attempt to answer the questions as to what are the most general assumptions we are here able to make consistent with the above hypotheses or which of these different assumptions lead to essentially different "double algebras"; but we shall introduce directly those hypotheses which characterize the theory of the so-called "*ordinary complex numbers*."

I. *The products of the units are accordingly defined by the equations:*

$$(3) \quad (1, 0) \cdot (1, 0) = (1, 0),$$

$$(4) \quad (0, 1) \cdot (1, 0) = (1, 0) \cdot (0, 1) = (0, 1),$$

$$(5) \quad (0, 1) \cdot (0, 1) = (-1, 0).$$

The meanings of these equations must be made clear.

From equation (3) and from the results of the previous paragraphs it follows that all computation with number-pairs, whose second elements are equal to 0, is to be performed just as if the second elements were entirely absent and that therefore we are to operate only with the first elements just as with simple numbers. Equation (4) and the distributive law tell us that the number-pair  $(a, 0)$  is to be treated as a simple number when multiplying it by another number-pair. We identify these special number-pairs directly with simple numbers as follows:

II. *Since we may put*

$$(6) \quad (1, 0) = 1,$$

*it follows according to equation (5), § 2, that in general*

$$(7) \quad (a, 0) = a.$$

Finally, equation (5), on account of equation (7), can be written

$$(8) \quad (0, 1) \cdot (0, 1) = -1.$$

Accordingly, it follows that:

III. *While there does not exist a simple number which multiplied by itself gives  $-1$ , there is a number-pair, viz.  $(0, 1)$  which has this property.*

The problem, to find a number which multiplied by itself produces a given number, is called in elementary algebra "Extraction of the square root" and is designated by  $\sqrt{\quad}$  (A. A. § 46). If we apply this symbol (provisionally without further discussion) to operations with number-pairs we can formulate Theorem III as follows:

IV. *The operation indicated by  $\sqrt{-1}$  is impossible in the field of simple numbers, but has  $(0, 1)$  for a solution with number-pairs.*

(Whether there are other number-pairs which satisfy this operation, remains temporarily undecided; but cf. § 58.)

Moreover, we shall put

$$(9) \quad (0, 1) = \sqrt{-1} = i,$$

thus using the symbol generally accepted since the time of GAUSS.

V. *Therefore according to equation (8), § 2, every number-pair can be written in the form*

$$(10) \quad (a, b) = a + bi.$$

We shall henceforth use a different terminology as follows:

VI. *What was heretofore named merely "a number" will hereafter be called "a real number"; and what we heretofore called a number-pair will henceforth be named "a number," or where a more explicit statement is desired, "a complex number" (a complex quantity).*

We therefore enlarge the custom of representing an indeterminate number by a letter, by *designating an arbitrary complex number by a letter* when the limitation to real numbers (or any other limitation) is not expressly stated or is not evident from the context.

VII. In the complex number  $a+bi$ ,  $a$  is called the *real part* and  $bi$  the *imaginary part*. A complex number whose real part is 0 is called a *pure imaginary* number.

One must not be led to a wrong conception by this *name*; as we shall soon see, complex numbers are very well suited to represent definite relations between real objects.

The symbols thus introduced will be used at once to state explicitly the following result:

VIII. For the *multiplication of any two complex numbers* we have, by applying formulas (1) to (5):

$$(11) \quad (a+bi)(c+di) = ac - bd + i(ad+bc).$$

The multiplication of complex numbers defined by this equation is thus possible in every case and the result is unique. That the methods for the multiplication of real numbers hold for these complex numbers is not self-evident, but must be proved (just as we proved the corresponding property for addition). In this it is sufficient to prove that the *fundamental laws* are valid permanently, in order to show that the laws derived from them remain valid; this has been so completely discussed in A. A. §§ 1, 9 as well as here, §§ 1, 2, that further discussion is not now necessary. Multiplication possesses three such fundamental laws, viz., the two stated at the beginning of this paragraph and the following:

$$(12) \quad (ab)c = a(bc),$$

which is called the *associative law* (A. A. IV, § 4). To verify the fact that these three laws hold also for the multiplication of

complex numbers as defined by equation (11), it is only necessary to carry out the indicated operations; this is left to the reader, and we state at once the theorem:

IX. *The three laws (1), (2), (12), as well as all the laws deduced from them, hold for multiplication as defined by equation (11).*

All deductions from equations are naturally again equations. But there is another important property of multiplication of real numbers which is not expressed by an equation, but by an *inequality*, and on this account cannot be deduced from the above three fundamental laws alone. We refer to the theorem that a product cannot be zero unless one of the factors is zero (A. A. § 13). We must then show in particular that this same theorem holds for complex numbers. If the right side of equation (11) is to be equal to zero, then, according to the definition of equality of two complex numbers given in I, § 2, we must have

$$\begin{array}{l} ac - bd = 0 \\ ad + bc = 0 \end{array} \quad \left| \begin{array}{l} c \\ d \end{array} \right| \begin{array}{l} -d, \\ c. \end{array}$$

It follows from these equations by multiplying by the adjoining factors that

$$(13) \quad \begin{array}{l} a(c^2 + d^2) = 0, \\ b(c^2 + d^2) = 0. \end{array}$$

The equation  $(c^2 + d^2) = 0$  can be satisfied by real values of  $c, d$ , only when  $c = 0$  and  $d = 0$ . But if  $c^2 + d^2 \neq 0$  then it follows from equations (13) that  $a$  must  $= 0$  and  $b$  must  $= 0$ , since the theorem just cited holds for real numbers. If therefore

$$(a + bi)(c + di) = 0,$$

either  $a + bi$  must  $= 0$  or  $c + di$  must  $= 0$ , that is, the following theorem holds for complex numbers:

X. *A product cannot be zero unless one of the factors is zero.*

#### § 4. Geometrical Representation of Complex Numbers by the Points of the Plane

At the beginning of our investigation (in § 2) we recalled a one-to-one correspondence between the totality of real numbers and the totality of points of a straight line, that is, an arrangement such that to each point there corresponds a definite number (the "abscissa" of the point) and to each number there corresponds a definite point. We have likewise pointed out that number-pairs can be arranged in correspondence with the points of a surface as a two-dimensional configuration. The simplest arrangement of this kind for the points of the plane is the following one due to DESCARTES: let us draw through a given point, the "origin" of coördinates, two straight lines, "the  $x$ - and the  $y$ -axis," perpendicular to each other; drop perpendiculars from any point of the plane on these axes, and designate the lengths cut off on the axes by these perpendiculars, measured from the origin and taken with the proper sign,\* as the "coördinates"  $x, y$  of the given point (Fig. 1). In this representation we need only to replace the number-pair  $(x, y)$  by the complex number  $x + iy$ ; we have thus the relation of the complex numbers to the points of the plane due to GAUSS and ARGAND:

I. *We associate with each complex number  $x + iy$  that point of the plane which has, in reference to a fixed rectangular system, the coördinates  $x, y$ ; and conversely, to each point with the coördinates  $x, y$  we associate the complex number  $x + iy$ .*

\* In general we shall take the positive  $x$ -axis to the right and the positive  $y$ -axis in front of the observer. But in any case let us think of the positive directions of the axes as so chosen that they can be brought into the position just indicated by mere turning in the plane without reflection. Whether we use this or the opposite arrangement is entirely immaterial. However, it is often convenient for the form of certain expressions to use a particular arrangement and at times, when the designation of signs is important, to use the usual arrangement. (Cf. A. A. §§ 11, 14.)

In this way there corresponds to each complex number one and only one point of the plane; and conversely, to each point of the plane there corresponds one and only one complex number. Accordingly, to each definite relation between points of the plane there must be a

corresponding definite relation between complex numbers, and conversely. From each theorem about complex numbers there follows a geometrical theorem about points of the plane; and conversely, to each geometrical theorem concerning points of the plane

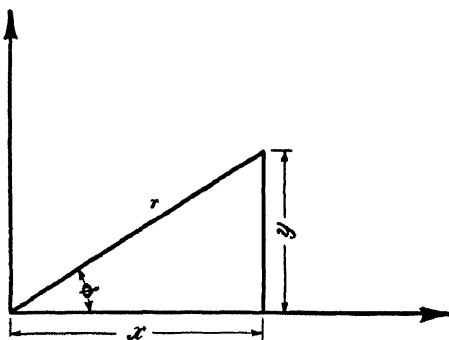

FIG. 1

there is a corresponding theorem about complex numbers. Of course, every such theorem must be proved "purely" by methods which belong only to each particular case; but powerful aids to investigation are furnished us by the application of known geometrical theorems to our function theory. This procedure is justifiable from the standpoint of rigor, whenever we are certain of the one-to-one correspondence between the objects analytically related and the geometrical picture, and whenever we use only rigorous geometrical theorems.

In particular, the points of the  $x$ -axis correspond to the real numbers (VI, § 3). It will therefore be called the *axis of real numbers*; to the pure imaginary numbers (VII, § 3) correspond the points of the  $y$ -axis (*axis of pure imaginary numbers*).\*

From the rectangular coördinates of a point we obtain its well-known polar coördinates, radius vector  $r$  and polar angle  $\phi$ , by

\* Also called "real axis" and "imaginary axis."

the equations (cf. Fig. 1):

$$(1) \quad \begin{aligned} x &= r \cos \phi, \\ y &= r \sin \phi, \end{aligned}$$

whose solution is:

$$(2) \quad r = \sqrt{x^2 + y^2}, \quad \phi = \tan^{-1} \frac{y}{x}.$$

The formulas (1) are also correct in sign if the positive direction of the angle be so chosen that the positive  $y$ -axis makes an angle of  $+\frac{\pi}{2}$  with the positive  $x$ -axis\* and if  $r$  is always taken as positive. The foundation for these statements from the theory of trigonometric functions of a real angle (A. A. § 76) is supposed to be known here.

II. *On the basis of equations (1) every complex number can be written in the form:*

$$(3) \quad z = x + iy = r(\cos \phi + i \sin \phi).$$

III. *Here  $r$  is the positive square root*

$$\sqrt{x^2 + y^2};$$

*it is called the ABSOLUTE VALUE † of the complex number  $z = x + iy$  and is designated by*

$$|z|.$$

*The square of the absolute value is called the NORM.*

The absolute value of a positive real number is the number itself. The absolute value of a negative real number is the same number with the opposite sign (A. A. § 10).

\* And thus with the usual arrangement for positive direction of axes, "counterclockwise" (A. A. § 11).

† Also called "modulus"; but this word has also other meanings.

IV. There is no definite name for the angle  $\phi$ . We find it designated as argument, declination, arcus, anomalie, *amplitude*.\* We shall use the last-named term.

V. *The factor*  $\cos \phi + i \sin \phi$   
(direction factor of the complex number) *has the property that its absolute value = 1.*

VI. *All the points corresponding to the numbers of absolute value 1 lie upon the unit circle, that is, upon the circle whose center is at the origin and whose radius is unity.*

Whether it is possible to put a complex number in the form (3) in only one way is quite an essential question. We notice in this connection that :

VII. *The absolute value  $r$  is uniquely defined, but there is an infinite number of values of  $\phi$  (as shown in goniometry) which satisfy the conditions; all these values can be obtained from any one of them by the addition and subtraction of arbitrary integral multiples of  $2\pi$  (A. A. § 76).* We must continually give attention to this many-valued character of the amplitude when using complex numbers in the form (3). It will be discussed again more completely in § 54.

VIII. *The number*

$$(4) \quad a - bi = r[\cos(-\phi) + i \sin(-\phi)] = r(\cos \phi - i \sin \phi)$$

*is called the complex number conjugate to  $a + bi$ .* Its geometrical representation is (cf. Fig. 2) the *reflection* of the point  $a + bi$  on the real axis. The number conjugate to the conjugate is the original number. The conjugate of the opposite (IV, § 2) is the opposite of the conjugate.

\* *Amplitude* is used by the translator instead of *arcus* and is denoted when convenient by am. — S. E. R.

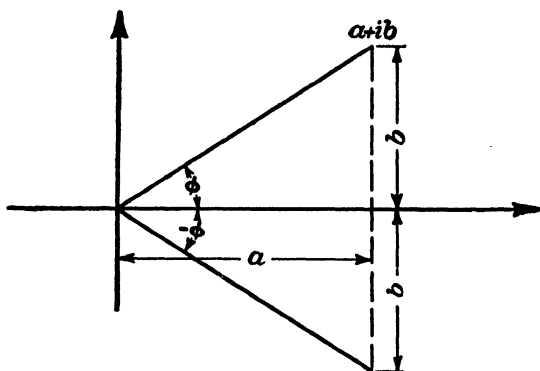

FIG. 2

### § 5. Geometrical Representation of Addition and Subtraction of Complex Numbers

From the points which represent geometrically the two complex numbers  $a + bi$  and  $c + di$ , we construct as follows the point which represents their sum :

I. *Connect the two given points with the origin by straight lines and complete the parallelogram thus determined; the fourth vertex is the point required.*

The proof is obtained from Fig. 3, in which the necessary auxiliary lines are drawn. That it also holds when the points do not both lie in the first quadrant follows from the agreements made in § 4 about the signs.

Another form of the rule is the following :

II. *Draw a line segment from the point  $a + bi$  in the same direction, of the same length, and parallel to the one from  $o$  to  $c + di$ ; its end point is then  $(a + bi) + (c + di)$ .*

The commutative law for addition, the properties of which were discussed in § 2, follows from the first form of the above rule and the associative law from the second form. Moreover

we obtain from this the first example of using a geometrical theorem for the purposes of analysis. We refer to the elementary geometrical theorem that in any triangle any side is not greater \*

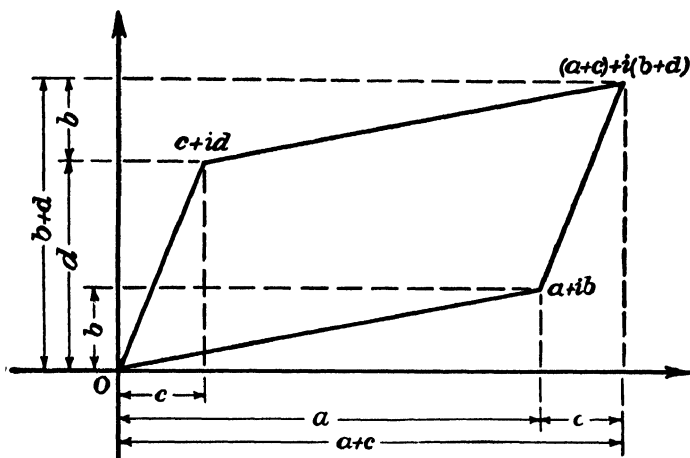

FIG. 3

than the sum (and not less than the difference) of the other two sides. The following important theorem having particular application in convergence proofs is obtained from this on the basis of definition III, § 4 :

III. *The absolute value of the sum of two complex numbers is not greater than the sum (and not less than the difference) of their absolute values.†*

\* This form of expressing the theorem brings to mind a limiting case which must not be excluded here, viz. where the triangle degenerates to a straight line.

† An algebraic proof of this theorem is the following :

$$\text{Since } |a + bi| = \sqrt{a^2 + b^2}, \quad |c + di| = \sqrt{c^2 + d^2},$$

$$|a + bi + c + di|^2 = (a + c)^2 + (b + d)^2,$$

then

$$\begin{aligned} & (|a + bi| + |c + di|)^2 - |a + bi + c + di|^2 \\ &= 2\sqrt{(a^2 + b^2)(c^2 + d^2)} - 2ac - 2bd \\ &= 2[\sqrt{a^2c^2 + b^2c^2 + a^2d^2 + b^2d^2} - \sqrt{a^2c^2 + 2abcd + b^2d^2}]. \end{aligned}$$

Repeated application of the first half of this theorem gives the following more general one:

IV. *The absolute value of the sum of an arbitrary number of complex numbers is not greater than the sum of their absolute values.*

The geometrical representation of *subtraction* is obtained by reversing the construction given in Fig. 3:

V. *To construct geometrically the point which represents the difference  $(a + bi) - (c + di)$ , connect the points  $(a + bi)$  and  $-(c + di)$  with the origin by straight lines and complete the parallelogram thus determined; its fourth vertex is the point required.*

Or:

Let  $a + bi$  be the origin of a line segment which is parallel and equal in length but oppositely directed to the one drawn from  $o$  to  $c + di$ ; its end point is then the required point.

### § 6. Geometrical Representation of Multiplication of Complex Numbers

The definition of the product of two complex numbers given in § 3, equation (11) may, according to the results of § 4, be put in a form by means of which the product can be constructed geometrically. Let

$$a + bi = r_1(\cos \phi_1 + i \sin \phi_1),$$

$$c + di = r_2(\cos \phi_2 + i \sin \phi_2),$$

But

$$(ad - bc)^2 \geq 0,$$

and accordingly

$$a^2d^2 + b^2c^2 \geq 2abcd;$$

therefore the expression in [ ] is not negative since the first root is to be taken as positive (the second root might be taken positive or negative).

Hence

$$|a + bi| + |c + di| \geq |a + bi + c + di|.$$

Q.E.D.

and therefore

$$(a + bi)(c + di) = r_1 \cdot r_2 [(\cos \phi_1 \cos \phi_2 - \sin \phi_1 \sin \phi_2) \\ + i(\sin \phi_1 \cos \phi_2 + \cos \phi_1 \sin \phi_2)].$$

But by the addition theorem for trigonometric functions (A. A. § 74) this is

$$(1) \quad = r_1 r_2 [\cos(\phi_1 + \phi_2) + i \sin(\phi_1 + \phi_2)].$$

The following theorem is thus evident :

I. *The absolute value of a product is equal to the product of the absolute values of the factors, the amplitude is equal to the sum of the amplitudes of the factors.*

We have seen in § 3 that the product of two complex numbers is single-valued ; then the value of this product must be the same whichever ones of the infinitely many values of the amplitude of the separate factors (VII, § 4) we select. In fact this is evident directly : if we increase the amplitude of a factor by an arbitrary multiple of  $2\pi$ , the amplitude of the product increases by the same multiple of  $2\pi$ , and hence the value of the product itself is not changed.

A special case worthy of notice is that for which  $r_2 = r_1$  and  $\phi_2 = -\phi_1$ , viz.,

$$(2) \quad (a + bi)(a - bi) = a^2 + b^2;$$

in other words :

II. *The product of two conjugate complex numbers is real and equal to their common norm.*

That the associative and the commutative laws hold for a product is at once evident from equation (1). Furthermore, this equation enables us to construct a product geometrically. In Fig. 4, let  $c$  be the point which represents the product  $ab$

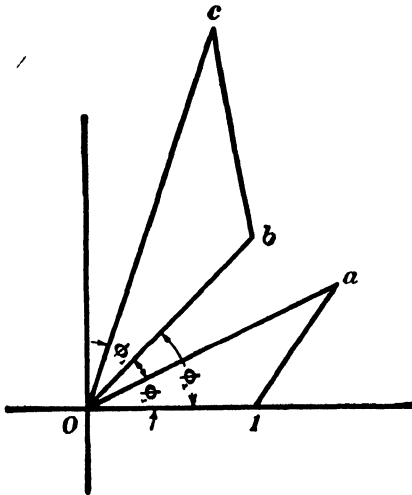

FIG. 4

geometrically; and if

$$\sphericalangle IOa = \phi_1,$$

$$\sphericalangle IOb = \phi_2,$$

$$\overline{oa} = r_1,$$

$$\overline{ob} = r_2,$$

then, in accordance with equation (1),

$$\sphericalangle IOc = \phi_1 + \phi_2,$$

$$\overline{oc} = r_1 \cdot r_2,$$

and thus

$$\sphericalangle boc = \phi_1 = \sphericalangle IOa;$$

$$\text{and } \overline{OI} : \overline{oa} = \overline{ob} : \overline{oc}.$$

Hence the triangles  $oia$  and  $obc$  are similar to each other in all respects and the required construction is the following:

III. *If  $a, b$  are the points which represent geometrically the numbers to be multiplied, construct the triangle  $obc$  similar in all respects to the triangle  $oia$ ; the third vertex  $c$  of this triangle represents the product  $ab$ .*

In this construction we use in addition to the origin the unit point on the  $x$ -axis; this was not the case for the construction of a sum in Fig. 3.

## § 7. Division of Complex Numbers

I. *The quotient of two complex numbers  $a : b$  is defined as that complex number  $c$  which, when multiplied by  $b$ , gives  $a$ .*

Following the method of representing a product as given in I, § 6, the solution of the problem indicated by this definition is

at once evident; thus

$$(1) \quad \frac{a}{b} = \frac{r_1}{r_2} [\cos(\phi_1 - \phi_2) + i \sin(\phi_1 - \phi_2)],$$

and hence

II. *The absolute value of the quotient of two complex numbers is equal to the quotient of their absolute values; its amplitude is equal to the difference of their amplitudes (equal to the angle  $\text{boa}$ ).*

Here also the many-valuedness of the amplitude has no effect upon the result. For, if we increase the value first selected for the amplitude of the dividend or of the divisor by  $2\pi$ , the amplitude of the quotient increases or decreases, respectively, by  $2\pi$  according to the above rule for determining the amplitude of a quotient. Neither the one nor the other changes the value of the result. Therefore,

III. *The division of two complex numbers is always a possible, single-valued, definite operation excepting the case where the divisor is equal to zero.*

Returning now from this trigonometrical representation of complex numbers to the original, we find

$$(2) \quad \frac{\alpha + \beta i}{\gamma + \delta i} = \frac{(\alpha\gamma + \beta\delta) + (-\alpha\delta + \beta\gamma)i}{\gamma^2 + \delta^2}.$$

On investigation of the special case where  $r_1 = r_2$ ,  $\phi_2 = -\phi_1$ , we find that

IV. *The quotient of two conjugate complex numbers is a number whose absolute value is 1.*

V. *The quotient of 1 by a complex number  $a$  is called (as with real numbers) the reciprocal of  $a$ .*

If  $a = \alpha + \beta i = r(\cos \phi + i \sin \phi)$   
then

$$(3) \quad \frac{1}{a} = \frac{\alpha - \beta i}{\alpha^2 + \beta^2} = \frac{1}{r}(\cos \phi - i \sin \phi).$$

From these formulas it is evident that, as with real numbers, the following theorem holds :

VI. *A complex number is divided by another when it is multiplied by the reciprocal of the latter.*

It therefore follows for division of complex numbers, that all the rules for manipulating are valid just as with real numbers. This result and the results of the preceding paragraphs are stated in the following theorem :

VII. *In the field of the four fundamental operations we may operate with complex numbers as with real numbers.*

It is important that we make the meaning of this statement entirely clear. It contains at once the *proposition* that there *are* combinations of number-pairs, which obey the same rules as the combinations of single, real numbers designated by the names addition, subtraction, etc. It contains further the *conventional agreement* that we shall retain for these combinations the same name and the same symbol which are already used for such combinations of single numbers.

There are *no* corresponding theorems for triple numbers, quadruple numbers, etc. It is possible to give combinations of these — and indeed in many ways — which obey *nearly* all the laws for operating with real numbers ; but there are no such numbers which can be combined according to *all* of these laws. The proof of this theorem is not within the scope of this book.\* We cannot even discuss the question whether or not it is desirable from certain points of view to introduce such “higher complex

\* Cf. D. HILBERT, *Gött. Nach.*, 1896, or O. STOLZ and A. GMEINER, *Theoretische Arithmetik*, Lpz. 1902, Chap. X.

numbers"\* and whether they would at once obey the laws of general arithmetic.†

If the order in elementary algebra is to be followed in the development of these numbers, we should take up next the so-called operations of the third grade, raising to powers, extraction of roots, and the finding of logarithms; but we shall postpone the discussion of them to later chapters (§§ 18, 56, 63) and at present seek new results in the field of the four fundamental operations by applying to the conceptions of algebra the notions of a variable quantity and of function belonging to analysis (A. A. § 19).

#### EXAMPLES

1. Show that  $(\cos \theta + i \sin \theta)^n = \cos n\theta + i \sin n\theta$  for  $n$  positive or negative, integral or fractional.

2. Put the following expressions in the form  $r(\cos \theta + i \sin \theta)$ :

$$1 + i; \quad \frac{1 + i\sqrt{3}}{2}; \quad 1 + \sqrt{2} + i; \quad \frac{(\cos A + i \sin A)^4}{(\cos B + i \sin B)^5};$$

$$\left( \frac{1 + \sin \theta + i \cos \theta}{1 + \sin \theta - i \cos \theta} \right)^n.$$

3. Find all the values of

$$(a) 1^{\frac{1}{3}}; \quad (c) (-i)^{\frac{1}{3}}; \quad (e) (\sqrt{3} - i)^{\frac{2}{3}};$$

$$(b) i^{\frac{1}{2}}; \quad (d) (1 + i\sqrt{3})^{\frac{1}{2}}; \quad (f) 32^{\frac{1}{5}}.$$

Find the values of  $\sqrt{i}$  in the form  $x + iy$ ,  $x$  and  $y$  real, and represent them graphically.

4. Find and represent graphically the cube roots of unity. Show that their sum is zero and that they form a geometrical series.

Show also that the  $n$ th roots of unity form a geometrical series.

\* An article by CHAPMAN, *Bulletin N.Y. Math. Society*, Vol. I, p. 150, entitled "Weierstrass and Dedekind on higher complex numbers," may be of interest to the reader from the point of view of the general theory. — S. E. R.

† Cf. H. HANKEL, *Theorie der complexen Zahlensysteme*, Lpz. 1867; also S. LIE, *Kontinuierliche Gruppen*, edited by G. Scheffers, Lpz. 1893, chap. 21.

5. Show that the two lines joining the points  $z = a$ ,  $z = b$  and  $z = c$ ,  $z = d$  will be perpendicular if

$$\text{am}\left(\frac{a-b}{c-d}\right) = \pm \frac{\pi}{2},$$

that is, if  $\left(\frac{a-b}{c-d}\right)$  is purely imaginary. Find the condition that these two lines shall be parallel. (Cf. I, § 9 and following.)

6. Show that if  $M$  is the middle point of  $CD$ ,  $OM = \frac{1}{2}(OC + OD)$  in which  $O$  is the origin in the complex plane.

7. Let  $A$  and  $B$  be any two points in the complex plane; we wish to find the complex quantity represented by  $AB$ . Connect each point with the origin  $O$ . Then, according to the definition and construction of the difference of two complex quantities,  $AB$  is equal to  $OB - OA$  (where  $AB$  means *from A to B*).

8. Given four points  $A, B, C, D$  on the axes at unit distance from the origin. Find the complex quantities which represent the distances  $AB, BC, CD, DA$ .

9. What complex quantities represent the vertices of the hexagon inscribed in the unit circle about the origin? What complex quantities represent the sides of this hexagon?

10. Given any three points  $A, B, C$  in the plane such that  $OA, OB, OC$  are non-collinear. To prove that it is always possible to express the relation between them in the form

$$OC = a \cdot OA + b \cdot OB \quad (a \text{ and } b \text{ are real});$$

and further that this representation is *unique*.

PROOF. — Draw  $MC$  parallel to  $OB$ . In the triangle  $OMC$ ,  $OM + MC = OC$  by addition. But  $OM = a \cdot OA$  since  $OM$  and  $OA$  differ only in absolute value; likewise  $MC = b \cdot OB$ . It follows that

$$OC = a \cdot OA + b \cdot OB.$$

Next, suppose a second representation

$$OC = a' \cdot OA + b' \cdot OB.$$

Therefore

$$(a - a') \cdot OA + (b - b') \cdot OB = 0;$$

but this means that  $O, A, B$  are collinear, contrary to the hypothesis, since then  $OA$  is equal to a constant times  $OB$ . Hence the representation is unique.

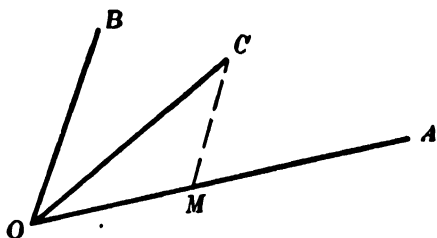

11. Construct  $w = 1/z$ , i.e.  $w : 1 = 1 : z$ .

12. Multiply 2 times 3 graphically. Illustrate WEIERSTRASS' definition of multiplication that to multiply  $a$  by  $b$ , operate on  $b$  as was done on unity to get  $a$ .

13. Prove geometrically that  $\left| \frac{a + ib}{b + ia} \right| = 1$ .

14. Find the points which divide the line segment from  $o$  to  $1$  in the ratios  $\pm (1 + i)$ .

15. Show by expanding  $(\cos \theta + i \sin \theta)^n$  and equating reals and imaginaries that

$$\cos n\theta = \cos^n \theta - \frac{n \cdot n - 1}{2} \cos^{n-2} \theta \sin^2 \theta + \dots$$

$$\sin n\theta = n \cos^{n-1} \theta \sin \theta - \frac{n \cdot n - 1 \cdot n - 2}{1 \cdot 2 \cdot 3} \cos^{n-3} \theta \sin^3 \theta + \dots$$

16. Show that

$$(a) \sin 3\theta = 3 \sin \theta \cos^2 \theta - \sin^3 \theta = 3 \sin \theta - 4 \sin^3 \theta;$$

$$(b) \cos 3\theta = \cos^3 \theta - 3 \cos \theta \sin^2 \theta = 4 \cos^3 \theta - 3 \cos \theta;$$

$$(c) \cos 4\theta = \cos^4 \theta - 6 \cos^2 \theta \sin^2 \theta + \sin^4 \theta.$$

Find similar expressions for  $\sin 4\theta, \cos 5\theta, \cos 6\theta, \sin 7\theta$ .

17. If  $\cos \theta + i \sin \theta = x$ , show that  $2 \cos n\theta = x^n + \frac{1}{x^n}$ ,

$2i \sin n\theta = x^n - \frac{1}{x^n}$ . Show also that

$$\begin{aligned} (2 \cos \theta)^n &= \left(x + \frac{1}{x}\right)^n = \left(x^n + \frac{1}{x^n}\right) + n \left(x^{n-2} + \frac{1}{x^{n-2}}\right) + \dots \\ &= 2 \cos n\theta + 2n \cos(n-2)\theta + \dots \end{aligned}$$

Derive a similar expression for  $\sin^n \theta$ , discussing the cases for  $n$  even and odd.

**18.** Expand  $\cos^5 \theta$  in a series of cosines of multiples of  $\theta$ .

HINT. — Put  $(2 \cos \theta)^5 = \left(x + \frac{1}{x}\right)^5 = \left(x^5 + \frac{1}{x^5}\right) + \dots$   
 $= 2 \cos 5\theta + \dots$

Expand similarly the following expressions:

$$\sin^5 \theta, \cos^7 \theta, \sin^8 \theta, \cos^5 \theta \cdot \sin^7 \theta.$$

**19.** Show that

$$(x + y\omega_3 + z\omega_3^2)(x + y\omega_3^2 + z\omega_3) = x^2 + y^2 + z^2 - yz - zx - xy.$$

**20.** Prove that  $(x^{2n} - 2x^n a^n \cos \theta + a^{2n}) = \left(x^2 - 2xa \cos \frac{\theta}{n} + a^2\right)$   
 $\left(x^2 - 2xa \cos \frac{\theta + 2\pi}{n} + a^2\right) \dots \left(x^2 - 2xa \cos \frac{\theta + 2(n-1)\pi}{n} + a^2\right).$

HINT. — Make use of the formula

$$(x^{2n} - 2x^n a^n \cos \theta + a^{2n}) = \{x^n - a^n (\cos \theta + i \sin \theta)\} \{x^n - a^n (\cos \theta - i \sin \theta)\},$$

resolving each of the last two expressions into  $n$  factors.

**21.** Show that the triangle  $xyz$  is equilateral if

$$x^2 + y^2 + z^2 - xy - yz - zx = 0.$$

HINT. — If  $ABC$  be the triangle, the line segment  $CA$  is  $BC$  turned through an angle  $\frac{2\pi}{3}$ ; and, since  $\cos \frac{2\pi}{3} + i \sin \frac{2\pi}{3} = \omega_3$  and  $\cos \frac{2\pi}{3} - i \sin \frac{2\pi}{3} = \frac{1}{\omega_3} = \omega_3^2$ , we have  $x - z = (z - y)\omega_3$  or  $(x - z) = (z - y)\omega_3^2$ . Hence  $x + y\omega_3 + z\omega_3^2 = 0$ , etc., and the result follows from Ex. 19.

**22.** Show that  $|a + b|^2 + |a - b|^2 = 2|a|^2 + |b|^2$ . How is this related to the geometrical theorem that, if  $M$  is the middle point of  $PQ$  and  $O$  is the origin,  $\overline{OP}^2 + \overline{OQ}^2 = 2\overline{OM}^2 + 2\overline{MP}^2$ ?

23. Show that the roots of  $8x^3 - 4x^2 - 4x + 1 = 0$  are

$$\cos \frac{\pi}{7}, \cos \frac{3\pi}{7}, \cos \frac{5\pi}{7}.$$

HINT. — Put  $(\cos \theta + i \sin \theta)^7 = -1$ , *i.e.*  $\cos 7\theta = -1$ . From this

$$\theta = \frac{\pi}{7}, \frac{3\pi}{7}, \frac{5\pi}{7}, \frac{7\pi}{7}, \frac{9\pi}{7}, \frac{11\pi}{7}, \frac{13\pi}{7}.$$

Expand  $(\cos \theta + i \sin \theta)^7 = -1$  by the binomial theorem and equate the real parts on each side. This gives

$$\cos^7 \theta - 21 \cos^5 \theta \sin^2 \theta + 35 \cos^3 \theta \sin^4 \theta - 7 \cos \theta \sin^6 \theta + 1 = 0, \quad \textit{i.e.}$$

$$(1) \quad 64 \cos^7 \theta - 112 \cos^5 \theta + 56 \cos^3 \theta - 7 \cos \theta + 1 = 0,$$

and its roots are

$$\cos \frac{\pi}{7}, \cos \frac{3\pi}{7}, \cos \frac{5\pi}{7}, \cos \frac{7\pi}{7}, \cos \frac{9\pi}{7}, \cos \frac{11\pi}{7}, \cos \frac{13\pi}{7}.$$

since (1) is the original equation  $\cos 7\theta = -1$ . But

$$\cos \frac{7\pi}{7} = -1, \quad \cos \frac{9\pi}{7} = \cos \frac{5\pi}{7}, \quad \cos \frac{11\pi}{7} = \cos \frac{3\pi}{7}, \quad \cos \frac{13\pi}{7} = \cos \frac{\pi}{7}.$$

The roots of (1) are thus:  $-1$ , and  $\cos \frac{\pi}{7}$ ,  $\cos \frac{3\pi}{7}$ ,  $\cos \frac{5\pi}{7}$  repeated twice.

Now put  $x = \cos \theta$  and (1) becomes

$$(x + 1)(8x^3 - 4x^2 - 4x + 1)^2 = 0.$$

Thus  $\cos \frac{\pi}{7}$ ,  $\cos \frac{3\pi}{7}$ ,  $\cos \frac{5\pi}{7}$  are the roots of

$$8x^3 - 4x^2 - 4x + 1 = 0.$$

24. Show that the two sets of points  $a, b, c$  and  $x, y, z$  in the complex plane form similar triangles if

$$\begin{vmatrix} a, & x, & 1 \\ b, & y, & 1 \\ c, & z, & 1 \end{vmatrix} = 0.$$

25. If the points  $x, y, z$  are collinear, show that *real* numbers  $p, q, r$  can be found such that

$$p + q + r = 0 \quad \text{and} \quad px + qy + rz = 0.$$

HINT. — Use the condition for the similarity of the triangle  $xyz$  and a certain other triangle on the real axis.

## CHAPTER II

### RATIONAL FUNCTIONS OF A COMPLEX VARIABLE AND THE CONFORMAL REPRESENTATIONS DETERMINED BY THEM

#### § 8. General Introduction; the Function $z + a$ and the Parallel Translation

IN this and the following paragraphs we discuss the case where one of the two complex numbers to be combined by our elementary operations is regarded as *fixed (constant)*, the other as *variable*, that is, as a symbol which is supposed to take different values throughout the course of the investigation. We state more definitely that we consider this variable as a number of *unlimited variation*, that is, as a symbol which may be regarded as representing *any* complex quantity whatever.\* We exhibit this distinction in the notation in that we follow the usual custom of designating constant quantities by the first and variables by the last letters of the alphabet.

This difference between constants and variables is clearly displayed in the form of an equation between two different variables. To begin with the simplest example, let us put

$$(1) \quad z' = z + a;$$

thus  $z$  and  $z'$  are both quantities which vary together. The variation of  $z'$ , however, depends in a definite way upon the variation of  $z$  according to the equation (1); on this account it

\* Thus a *variable* is a symbol which represents any one of a set of numbers while a *constant* is a special case of a variable where the set consists of but one number. For this and the definition and history of a *function*, cf. VEULEN and LENNES, *Infinitesimal Analysis* (Wiley and Sons), p. 44. — S. E. R.

is called a function \* of  $z$  and in fact a rational function. We define as follows :

I. A complex variable  $z'$  is called a RATIONAL FUNCTION of another variable,  $z$ , when it is possible to deduce it from  $z$  and constants by a finite number of additions, subtractions, multiplications, and divisions.

II. If there are no quotients † in this function it is called a rational INTEGRAL function.

If we represent  $z$  and  $z'$  geometrically in two different planes, then an equation of the form :

$$(2) \quad z' = f(z)$$

determines a representation ‡ (a map) of the  $z$ -plane on the  $z'$ -plane in such a manner that to each point  $z$  of the first plane, there corresponds a point  $z'$  of the second. If, however, we represent  $z$  and  $z'$  on the same plane and refer them to the same axes, then by such an equation each point  $z$  of the plane is set in correspondence with a definite point  $z'$  of the same plane. It represents, as we say, a transformation of the plane into itself.

In regard to equation (1) in particular, it is shown in Fig. 3 that each point  $z'$  is obtained from the corresponding point  $z$  by moving the whole plane parallel to itself in the direction and the length of the line segment  $\overline{oa}$  :

\* We shall later (in § 33) define the phrase "Function of a Complex Variable" in a sense more restricted than the one given here. It will then be shown that the rational functions to be treated in this chapter are also in that restricted sense "Functions" of their arguments. For this reason it is allowable to define "Rational Function of  $z$ " without giving a previous formal definition of what is in general understood by "Function of  $z$ ."

† Only such divisions are to be excluded for which the denominator depends upon  $z$ . Division by a constant is multiplication by its reciprocal, *that is*, by a constant (A. A. § 20).

‡ This idea of the geometrical representation of the dependence of  $z'$  on  $z$  as a transformation or a mapping of the  $z'$ -plane on the  $z$ -plane is due to RIEMANN, *Grundlagen für eine allgemeine Theorie der Funktionen*, Werke, p. 5.—S. E. R.

III. *The transformation of the plane into itself determined by equation (1) is a parallel displacement (a translation) in direction and distance equal to  $\overline{oa}$ .*

In particular,

IV. *When the relation between  $z$  and  $z'$  is represented by equation (1), any figure formed by  $z'$ -points is congruent to the one formed by the corresponding  $z$ -points.*

### § 9. The Function $az$

The next simple rational function of  $z$  to be considered is the product of  $z$  and a constant  $a$ , viz. :

$$(1) \quad z' = az.$$

We ask now what kind of transformations of the plane into itself, that is, what kind of mappings of the  $z$ -plane on the  $z'$ -plane, are possible by means of this equation? We exclude first of all the case

$$a = 0,$$

since in this case  $z' = 0$  whatever the value of  $z$  may be, and consequently there is no proper transformation. We now consider two important special cases :

*First:* let  $a$  be a number whose absolute value is 1; then (V, § 4)

$$(2) \quad a = \cos \alpha + i \sin \alpha,$$

in which  $\alpha$  is a real angle. The graphical construction of a product given in Fig. 4, § 6, shows that the line segment  $\overline{oz'}$  is equal in length to the line segment  $\overline{oz}$ , but that it makes with the  $x$ -axis an angle increased by the constant  $\alpha$ . Each point  $z'$  will then be obtained from its corresponding point  $z$  by rotating the whole plane about the origin through the angle  $\alpha$ ; in other words:

I. *The transformation of the plane into itself by means of the equation*

$$z' = (\cos \alpha + i \sin \alpha)z \quad (\alpha \text{ real})$$

*is effected by rotating it about the origin through the angle  $\alpha$ .*

(In particular,  $z' = iz$  determines a rotation through a right angle,  $z' = -z$  a rotation through two right angles.)

Moreover,

II. *In this case (as in § 8), the figures formed from the  $z'$ -points are congruent to the ones formed by the corresponding  $z$ -points.*

*Second:* let  $a$  be a real positive number  $r$ . Then any point  $z$  and its corresponding point  $z'$  lie on a straight line through the origin (cf. Fig. 4) and are so related that the length of the line segment  $\overline{oz'}$  has a constant ratio to that of  $\overline{oz}$ . We say:

III. *The transformation of the plane into itself by means of the equation*

$$z' = rz$$

*(in which  $r$  is real and positive) is effected by stretching it from the origin.*

(If  $r < 1$ , the distance from the origin is *shortened* instead of *lengthened*; the word "stretching" will include both cases.)

IV. *Any figure formed by the  $z'$ -points by means of this transformation is not congruent to the one formed by the corresponding  $z$ -points, but is similar to it.*

Having thus disposed of these two special cases, let us consider the general case of the transformation (1). Multiplication by  $a$ ,

$$a = r(\cos \alpha + i \sin \alpha),$$

obeys the associative law for products (equation (12), § 3); we may therefore first multiply by  $r$  and then by  $(\cos \alpha + i \sin \alpha)$ . Consequently,

V. *The general transformation (1) is effected by a rotation about the origin through the angle  $\alpha$  (= the amplitude of  $a$ ) and a stretching from this point in the ratio  $|a| : 1$ . It is a "similarity" transformation with the origin as center of the similarity (that is, figures are transformed into similar figures).\**

Moreover, from the commutative law for multiplication we have the theorem that the result is independent of the order of the operations of stretching and rotating. It is customary to express it in this way:

VI. *Stretching from a point and rotating about it are permutable operations.*

### § 10. The Linear Integral Function and the General "Similarity" † Transformation

I. *If a complex variable  $z'$  depends upon another,  $z$ , according to the relation*

$$(1) \quad z' = az + b,$$

*in which  $a, b$  are arbitrary complex constants, then we say that  $z'$  is a linear integral function of  $z$ .*

As in § 9 we exclude the case  $a = 0$ ; for, in this case equation (1) represents no proper transformation of the plane into itself, since the fixed point  $z' = b$  corresponds to an arbitrary point  $z$  (that is, the  $z$ -plane is transformed into the fixed point  $z' = b$ ).\* But if

$$(2) \quad a \neq 0,$$

transformation (1) can be compounded in various ways from the simpler transformations already discussed. We can, for

\* Words in the parenthesis inserted by the translator.

† Cf. V, § 9, and V, § 10.—S. E. R.

example, introduce the auxiliary variable  $z''$  by the equation

$$(3) \quad z'' = az;$$

it then follows that

$$(4) \quad z' = z'' + b.$$

II. *The transformation determined by (1) is therefore obtained by stretching from the origin and rotating about it (equation 3), following with a translation (equation 4).*

But we might also introduce first an auxiliary variable  $z'''$  (always assuming equation 2) by the equation

$$(5) \quad z''' = z + \frac{b}{a};$$

in consequence of this

$$(6) \quad z' = az''.$$

III. *Therefore, the general transformation (1) is also performed by first displacing the plane parallel to itself, then stretching and rotating.*

In this connection we notice that the coefficient of stretching and rotating in (6) is the same as in (3), but that the coefficients of the parallel translations in (4) and (5) agree only for  $a = 1$ , that is, when there is no stretching and rotating. We now state this explicitly as follows (cf. Theorem VI, § 9):

IV. *Parallel translation on the one hand, stretching and rotating on the other, are not permutable operations.*

We come now to a third important representation of the transformation of the plane into itself by means of (1) by discussing the question whether there are definite points which remain fixed for this transformation, that is, expressed analytically, whether there are values  $z$  which coincide with the values  $z'$  corresponding to them according to (1). For every such value,

$$(7) \quad z = az + b;$$

for  $a \neq 1$ , this equation has one and only one root; denote it by  $\zeta$  and we obtain:

$$(8) \quad \zeta = \frac{b}{1-a} \quad \text{and} \quad \zeta(1-a)$$

By substituting the value of  $b$  from equation (8) in equation (1), it becomes:

$$(9) \quad z' - \zeta = a(z - \zeta).$$

Transformation (1) can therefore be performed by applying successively the three simpler transformations:

$$z'' = z - \zeta, \quad z''' = az'', \quad z' = z''' + \zeta;$$

in other words, we so translate the plane parallel to itself that the fixed point  $z = \zeta$  coincides with the origin; we then apply a stretching from this point and a rotation about it; and finally return this point to its first position  $z = \zeta$ . But, as is evident geometrically, we obtain the same result if we stretch from the point  $z = \zeta$  and rotate about it. Hence the following theorem:

V. *If  $a \neq 1$  the transformation of the plane into itself according to (1) is performed by rotating through the amplitude of  $a$  about the point:*

$$z = \frac{b}{1-a},$$

*and stretching from this point in the ratio  $|a|:1$ . In this way each figure is transformed into a similar one.*

We can also obtain the same result in a somewhat different manner. An equation of the form

$$(10) \quad Z = f(z)$$

can be given a different interpretation from that in § 8. Instead of regarding  $Z$  and  $z$  as complex numbers which belong to *two different points* of the plane in reference to the *same sys-*

tem of coördinates, we can look upon this equation as assigning another complex number  $Z$  to that point which, for a definite system of coördinates, represents the complex number  $z$ . For a particular form

$$(11) \quad Z = z - \zeta$$

of equation (10), this number  $Z$  can be defined as follows: By making the point called  $\zeta$  in the old system the origin of a new system of coördinates, whose axes are parallel to the old and whose unit of length is the same as in the old system, we obtain the point which is called  $z$  in the old [ $Z$  in the new] system of coördinates. The point called  $z'$  in the old coördinates is, in the new system, assigned to the number:

$$(12) \quad Z' = z' - \zeta.$$

The relation between the points  $z$  and  $z'$ , expressed in the old system of coördinates by equations (1), (9), is expressed in the new system by the equation:

$$(13) \quad Z' = aZ,$$

that is, it is a "similarity" transformation whose center of similarity is called  $o$  in the new system and  $\zeta$  in the old. We have thus deduced Theorem V in a new way.

But we can also prove the converse of this theorem. For, a "direct" similarity transformation of the plane is determined whenever the points  $z_1'$ ,  $z_2'$  corresponding to two different points  $z_1$ ,  $z_2$  are given; every third point  $z_3$  then has its corresponding point  $z_3'$  fixed uniquely from the fact that the triangles  $z_1z_2z_3$  and  $z_1'z_2'z_3'$  must be similar throughout, including the sense of corresponding angles. But we can always determine a transformation of the form (1) which transforms  $z_1$ ,  $z_2$  respectively into  $z_1'$ ,  $z_2'$ . For this purpose it is only necessary that  $a$  and  $b$  satisfy the equations:

$$(14) \quad z_1' = az_1 + b, \quad z_2' = az_2 + b;$$

but from these equations the values :

$$(15) \quad a = \frac{z_2' - z_1'}{z_2 - z_1}, \quad b = \frac{z_1'z_2 - z_2'z_1}{z_2 - z_1}$$

are finite and determinate providing  $z_2 \neq z_1$ ; we can say :

VI. *Every transformation of the plane into itself, which transforms any figure of the plane into a similar one, including the sense of corresponding angles, is expressed in the form (1).\**

For the purposes of later applications we express the conditions for the similarity of two triangles, including the sense of corresponding angles, in terms of the complex numbers representing their vertices. If the triangles  $z_1z_2z_3$  and  $z_1'z_2'z_3'$  are similar, then the values of  $a$  and  $b$  in (15) must also satisfy the equation :

$$z_3' = az_3 + b;$$

this is true if and only if

$$(16) \quad \frac{z_3' - z_1'}{z_3 - z_1} = \frac{z_2' - z_1'}{z_2 - z_1}.$$

In this equation we can put the letters with primes on one side and those without primes on the other side of the equality sign and formulate the theorem as follows :

VII. *The necessary and sufficient condition for the similarity in all of their parts of two triangles  $z_1z_2z_3$  and  $z_1'z_2'z_3'$  is, that the quotient*

$$(17) \quad \frac{z_3 - z_1}{z_2 - z_1} = \frac{z_3' - z_1'}{z_2' - z_1'}.$$

We can obtain the same result geometrically. For, the absolute value of the difference  $z_2 - z_1$  is, according to V, § 5, equal

\* As an example of how geometrical theorems result from operations with complex numbers, we cite the theorem following from V and VI :

Every direct similarity transformation of the plane which is not merely a parallel translation can be considered as a rotation about a point which is fixed by the transformation, and a stretching from this point.

to the length of the line segment from  $z_1$  to  $z_2$ , its amplitude is equal to the angle which this segment makes with the positive half of the real axes; and similarly for the difference  $z_3 - z_1$ . The absolute value of the quotient on the left side of equation (17) is then equal to the ratio of the lengths of two sides of the triangle  $z_1z_2z_3$ , its amplitude is equal to the angle inclosed by these lengths; and since corresponding interpretations can be made for the right side of (17), the equation expresses the similarity of the two triangles  $z_1z_2z_3$  and  $z_1'z_2'z_3'$ . That the sense of corresponding angles is also the same follows from the fact that, in this kind of investigation, the amplitude of a complex number has a definite sign.

Occasionally equation (17) is used in the determinant form:

$$(18) \quad \begin{vmatrix} z_1' & z_1 & 1 \\ z_2' & z_2 & 1 \\ z_3' & z_3 & 1 \end{vmatrix} = 0.$$

### EXAMPLES

1. Given  $z' = iz$ : Determine the change effected by this transformation in the following figures (*that is*, determine the figure in the  $z'$ -plane which corresponds by this transformation to the following figures in the  $z$ -plane, the two planes regarded either as coincident or as separate).

- (a) The square whose vertices are the points  $\pm 1 \pm i$ ;
- (b) The unit circle whose center is at the origin;
- (c) The triangle whose vertices are the points  $0, 1 + i, 1 + 2i$ .

2. Apply each of the following transformations to the configurations of Ex. 1 and note the change:

- (a)  $z' = z + i$ ;
- (b)  $z' = z + 3i$ ;
- (c)  $z' = z + (1 + \sqrt{3})i$ .

3. Discuss the transformation  $z' = z + (1 + \sqrt{3}i)$  by putting

$$z' = x' + iy' \text{ and } z = x + iy.$$

4. Regarding the  $z'$ -plane and the  $z$ -plane as coincident, determine the configuration corresponding to each of the configurations of Ex. 1 for each of the following transformations:

$$(a) z' = 2z;$$

$$(b) z' = (i/2)z;$$

$$(c) z' = (1 + i)z;$$

$$(d) z' = (1 + i)z + (1 + \sqrt{3}i).$$

5. Determine the linear integral transformations of the form  $z' = az + b$  which transform:

(a) The point  $-1$  into the point  $0$  and the point  $0$  into the point  $+2$ ;

(b) The point  $-1$  into the point  $0$  and the point  $0$  into the point  $-2$ ;

(c) The points  $i$  and  $-i$  respectively into the points  $+2$  and  $-2$ ;

6. *Perform geometrically* the transformations in Ex. 5.

7. Perform the transformation

$$z' = (1 + i)z + (1 + \sqrt{3}i).$$

1st. By stretching and turning and then rotating.

2d. By translating and then stretching and turning.

3d. By reducing the equation to the form  $z' - G = a(z - G)$ ,  $G$  being the invariant point, transferring the origin to the point  $G$ , stretching and rotating, etc.

### § 11. The Function $\frac{1}{z}$ and the Transformation by Reciprocal Radii

The investigation of the quotient, considered as a function of the dividend, resolves itself, on account of theorem VI, § 7, into the investigation of a product discussed in § 9; considered

as a function of the divisor its investigation may be referred, on account of the same theorem, to the case in which the numerator is 1. The question then is: What transformation of the plane into itself is determined by the function:

$$(1) \quad z' = \frac{1}{z} ?$$

To investigate this, put

$$z = x + iy = r (\cos \phi + i \sin \phi),$$

$$z' = x' + iy' = r' (\cos \phi' + i \sin \phi');$$

according to equation (3), § 7, we therefore obtain:

$$(2) \quad r' = \frac{1}{r}, \quad \phi' = -\phi$$

and therefore 
$$x' = \frac{x}{x^2 + y^2}, \quad y' = \frac{-y}{x^2 + y^2}.$$

The transformation determined by these equations may be regarded as compounded from two simpler geometric transformations, each of which considered by itself is not determined by rational functions of a complex variable. Let us first introduce the auxiliary transformation:

$$(4) \quad \bar{r} = r, \quad \bar{\phi} = -\phi, \quad \left. \begin{array}{l} \text{or} \\ (5) \quad \bar{x} = x, \quad \bar{y} = -y. \end{array} \right\}$$

And therefore to obtain transformation (1), we must after this put

$$(6) \quad r' = 1/\bar{r}, \quad \phi' = \bar{\phi},$$

or

$$(7) \quad x' = \frac{\bar{x}}{x^2 + y^2}, \quad y' = \frac{\bar{y}}{x^2 + y^2}.$$

I. Equations (4), (5) (cf. VIII, § 4) effect the transition from any complex number to its conjugate, thus determining geometrically a reflection on the axis of reals.

II. The transformation determined by equations (6) is called (on account of the first one of them) the transformation by reciprocal radii with reference to the unit circle — also called reflection\* on the unit circle. It is important that we investigate its most essential properties.

III. Transformation (6) is involutonic; that is, by means of it pairs of points correspond mutually to each other; (or more explicitly, if  $P$  be transformed into  $P'$  and by the same transformation  $P'$  goes into  $P$ , the transformation is involutonic).† Equations (6) are unchanged if  $r'$  is interchanged with  $\bar{r}$  and  $\phi'$  with  $\bar{\phi}$ . This same property does not follow so directly from

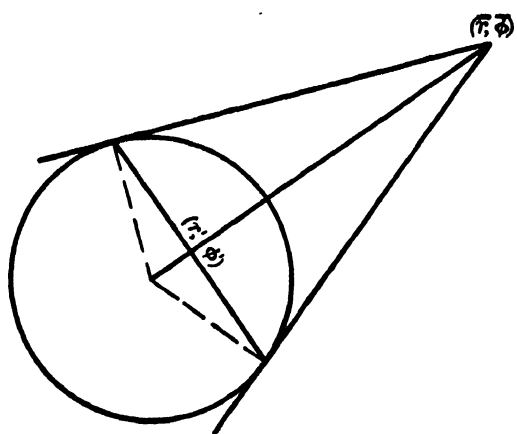

FIG. 5

equations (7), but is easily deduced.

IV. If the point  $(\bar{r}, \bar{\phi})$  lies outside of the unit circle, the point  $(r', \phi')$  is the intersection of the chord of contact of tangents from  $(\bar{r}, \bar{\phi})$  to the unit circle with the diameter prolonged through  $(\bar{r}, \bar{\phi})$  (cf. Fig. 5).

The point which corresponds to a point lying inside of the unit circle is obtained (on account of III) by reversing this construction. Every point on the unit circle corresponds to itself.

A further important property of this transformation is that

\* In an applied sense the law of reflection in optics is different. On the other hand, the transformation treated here is important in electrostatics. When used there it is spoken of as "The Principle of the Thomson Images."

† Words in the parenthesis added by the translator.

circles transform into circles, that is, all the points on a given circle are transformed into points which lie again on a circle. For if the coördinates  $\bar{x}$ ,  $\bar{y}$  of a point satisfy the equation :

$$(8) \quad a(\bar{x}^2 + \bar{y}^2) + b\bar{x} + c\bar{y} + d = 0,$$

which represents any arbitrary circle for suitably chosen coefficients, then, according to (7),  $x'$ ,  $y'$  satisfy the equation :

$$(9) \quad d(x'^2 + y'^2) + bx' + cy' + a = 0,$$

which in general again represents a circle except for  $d=0$  when it is a straight line. The above statement is therefore correct if a straight line is regarded as a special case of a circle. The following are more precise statements of these facts :

*V. To a circle which does not go through the origin ( $a \neq 0$ ,  $d \neq 0$ ) there corresponds a circle which does not go through the origin; to a circle through the origin ( $a \neq 0$ ,  $d = 0$ ) there corresponds a straight line which does not go through the origin; a straight line through the origin ( $a = 0$ ,  $d = 0$ ) corresponds to itself.*

We also add :

*Va. To parallel straight lines correspond circles with a common tangent at the origin.*

Further, the transformation by reciprocal radii has the property that angles are preserved, that is, that the angle of intersection of two curves is equal to the angle of intersection of the corresponding curves. The correctness of this statement can be shown best by considering first the special case in which one of the two curves is a straight line through the origin. Thus if  $PP'$  and  $QQ'$  are two pairs of corresponding points (Fig. 6), it then follows according to equation (6) that

$$\overline{OP} \cdot \overline{OP'} = \overline{OQ} \cdot \overline{OQ'} = 1;$$

and hence

$$\Delta OPQ \sim \Delta OQ'P';$$

and in particular :

$$(10) \quad \sphericalangle OPQ = \sphericalangle OQ'P'.$$

If we allow the point  $Q$  to approach the point  $P$  along a given curve, then the point  $Q'$  approaches the point  $P'$  upon the cor-

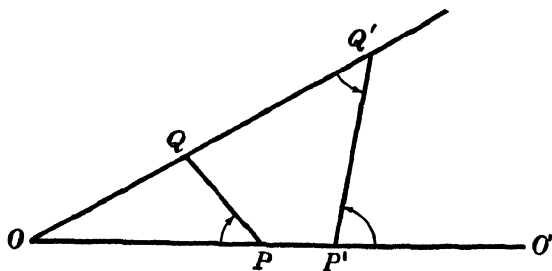

FIG. 6

responding curve;  $PQ$ ,  $P'Q'$  become the directions of the tangents to the curves,  $\sphericalangle OQ'P'$  in the limit will be equal to  $\sphericalangle O'P'Q'$ , and it therefore follows that in the limit

$$(11) \quad \sphericalangle OPQ = \sphericalangle O'P'Q'. \quad \text{Q.E.D.}$$

We notice further in this connection that the equality sign refers only to the *absolute value* of the angle; the two angles corresponding to each other are opposite in *sense*, and the resulting theorem is completely formulated as follows :

Two curves corresponding to each other form with any straight line corresponding to itself, angles which are equal but of opposite sense.

Moreover, since the angle between any two lines is equal to the sum (difference respectively) of the two angles which the two lines make with a third, it follows that :

VI. *The angle in which any two curves intersect is equal in the opposite sense to the angle of intersection of the two curves which correspond to the first two by the transformation by reciprocal radii.*

Since this transformation is of frequent occurrence, a name is given to it as in the following definition :

VII. *A transformation, under which the angle between any two curves is equal to the angle between the corresponding curves, is called a conformal representation\* (also isogonal representation, or a mapping with preservation of angles, or one "similar in infinitesimal parts").*

Therefore, according as the sense of the angle obtained is preserved or changed, we speak of the representation as conformal "*without*" or "*with inversion of angles.*" With this terminology Theorem VI is stated as follows :

VIII. *The transformation by reciprocal radii is a conformal representation with inversion of angles.*

Reflection on the  $x$ -axis determined by equations (4) or (5) is a representation of the same kind. If we now combine transformations (4) and (6) in order to obtain the original transformation (1), the two changes in the sense of the angle, being opposites, mutually disappear. We can then say — and it is the most important result of this paragraph :

IX. *The transformation effected by  $z' = 1/z$  is a conformal representation without inversion of angles.*

### EXAMPLES

1. Prove *analytically* that every circle which cuts the unit circle orthogonally is transformed into itself by the transformation by reciprocal radii.
2. Prove Ex. 1 *geometrically*.

\* *Konforme Abbildung* was the term used by GAUSS, *Ges. Werke*, Vol. IV, p. 262, and adopted universally by German mathematicians. CAYLEY used the term *orthomorphosis* or *orthomorphic transformation*. In general it is the process of establishing the infinitesimal similarity of two planes by means of a functional relation between the variables of the planes. Cf. also § 34. — S. E. R.

3. Prove the converse of Ex. 1 for the same transformation,
4. Transform by reciprocal radii a given system of parallel straight lines. Do the same for the system of straight lines orthogonal to the given system. Compare the two systems of circles obtained.
5. Transform by reciprocal radii the system of straight lines through a fixed point  $(a + bi)$ . Discuss four cases according as this fixed point is
- (a) At the origin ;
  - (b) On the unit circle ;
  - (c) Inside of the unit circle ;
  - (d) Outside of the unit circle.
6. Transform by reciprocal radii the system of circles with their centers at  $(a + bi)$  and orthogonal to the system of Ex. 5, discussing the same four cases as in Ex. 5. Draw carefully the accompanying diagrams for both Exs. 5 and 6.

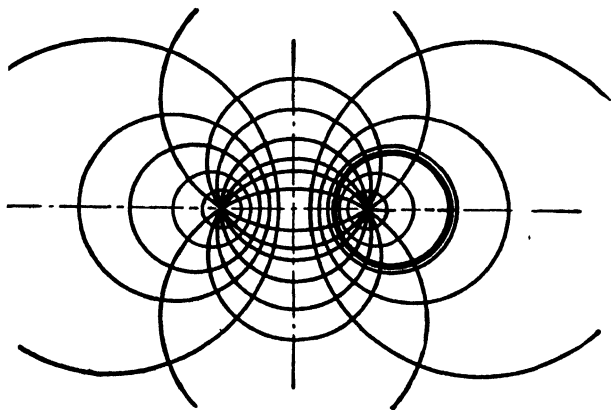

HINT.—The lines through  $P(a + bi)$  transform into circles through the origin and through  $P'$  (the transform of  $P$ ), while the circles with their centers at  $(a + bi)$  are transformed into circles orthogonal to the first set.

### § 12. Division by Zero; Infinite Value of a Complex Variable

While addition, subtraction, and multiplication in the field of complex numbers are, as we have seen, without exception possible operations, this is not the case with division. Among the numbers introduced by us so far there are none which, when multiplied by zero, give a definite number  $a$  different from zero, and hence none which could be the result of the division indicated by

$$\frac{a}{0}$$

as this operation is defined in § 7. The function  $z' = 1/z$  discussed in the above paragraph is accordingly not defined for  $z = 0$ . We may express it otherwise in this way: when the  $z$ -plane is represented conformally upon the  $z'$ -plane, the origin in the  $z$ -plane is an exceptional point in the representation since there is no point in the  $z'$ -plane which corresponds to it.

But it is customary in mathematics to remove such exceptions by suitable agreements. We make such an agreement here in the following definition:

I. *In addition to the complex numbers and their symbols already introduced we introduce now a new one, "infinity," with the symbol  $\infty$ , which is to be regarded as the result of the division  $1/0$ .*

This analytic definition is parallel to the following geometrical one:

II. *In addition to the points of the plane at finite distances from the origin let us assign to the plane an infinitely distant point which may be regarded as the one corresponding to the origin in the transformation by reciprocal radii.*

It is necessary now to determine the application of these terms and symbols. Analytically, we state the following definitions:

$$(1) \quad \text{III. } a + \infty = \infty + a = \infty,$$

$$(2) \quad \text{IV. } a \cdot \infty = \infty \cdot a = \infty, (a \neq 0),$$

from which it is evident that the fundamental laws of addition and multiplication spoken of in §§ 2 and 3 are satisfied. From these we get the following definitions for the inverse operations :

$$(3) \quad \infty - a = \infty,$$

$$(4) \quad a - \infty = \infty,$$

$$(5) \quad \frac{a}{\infty} = 0,$$

$$(6) \quad \frac{\infty}{a} = \infty, (a \neq 0).$$

The symbols  $\infty \pm \infty$ ,  $0 \cdot \infty$ ,  $\frac{0}{0}$ ,  $\frac{\infty}{\infty}$

remain completely undetermined, inasmuch as any number satisfies the operations demanded by them. Thus it is evident that the desire to remove by these definitions the exceptions to the theorems has been very imperfectly attained. For, while we have no additional case for which one of our operations would be impossible, yet we now have five indeterminate forms instead of the one,  $0/0$ .

Geometrically, we shall be content for the present to observe that the expression "A circle through two points in the finite part of the plane and the point at infinity" signifies the same thing as "A straight line through these two points." Thus Theorem V, § 11 takes the following simple form: *A circle through three points corresponds to the circle through the three corresponding points*; further details are postponed to later paragraphs.

According to conventions of this kind, certain words and symbols previously defined are assigned a wider meaning. That this procedure is permissible we have repeatedly stated in the first chapter; that it is useful is justified by results. We cannot object to this on the ground that in another province of

plane geometry, the projective, another convention (infinitely many infinitely distant points, which lie on a straight line at infinity) proves to be of practical value; we cannot expect that one and the same convention will suffice for all our purposes.

In elementary analysis the word "infinite" is used only in theorems in a qualified sense (cf. A. A. § 63). We speak here of infinite as a fixed value. The relation of these two ideas will be determined at our convenience (§ 31) after we have fixed upon the elementary meaning of infinity as applied to complex numbers.

### § 13. Transition from the Plane to the Sphere by Stereographic Projection

Up to this time we have represented the complex numbers by the points of the plane, but in introducing this representation (in § 4) we called attention to the fact that any surface could be used. In particular, the *sphere* lends itself readily to this purpose. We therefore wish to apply to it the representation of complex numbers by the points in the plane, which we have already introduced. We proceed as follows:

I. *Place a sphere\* of unit diameter on the  $xy$ -plane (considered horizontal) so that it touches the plane at the origin  $O$ . The highest point of the sphere—that one which lies diametrically opposite to  $O$ —will be called  $O'$ . From this point  $O'$ , project the points of the plane on the sphere by straight lines.*

This kind of projection has been used since the earliest times in cartography under the name of *stereographic projection*. Its most important properties are the following:

\* This sphere is called NEUMANN'S sphere. In following out one of RIEMANN'S ideas Neumann chose the sphere instead of the plane as the field of the complex variable. It is used by Neumann throughout his treatise, *Vorlesungen über Riemann's Theorie der Abelschen Integrale* (Leipzig, Teubner, 2d ed., 1884). —S. E. R.



$\pi P$ ) \* and cut it accordingly in the same angle. Hence, the two angles under comparison are equal. Q.E.D.

In this projection, points of the plane indefinitely near each other are transformed into points indefinitely near each other on the sphere, and hence curves in the plane tangent to each other are transformed into curves tangent to each other on the sphere. Consequently, the following generalization of Theorem V is at once possible :

VI. *Any two curves of the sphere cut each other at each of their points of intersection in the same angle as the corresponding curves of the plane at the corresponding points of intersection.*

We deduce further theorems with the aid of analytical geometry. We introduce the  $\xi, \eta, \zeta$  rectangular space coördinates of which the  $\xi$ - and the  $\eta$ -axes coincide respectively with the  $x$ - and the  $y$ -axes of the  $(x + iy)$ -plane, while the positive direction of the  $\zeta$ -axis is that of  $OO'$ . In this system of coördinates the equation of the sphere is

$$(1) \quad \xi^2 + \eta^2 = \zeta(1 - \zeta).$$

The point  $(\xi, \eta, \zeta)$  of the sphere corresponds to the point of the plane whose coördinates are  $x, y$  and radius vector  $r = \sqrt{x^2 + y^2}$ . To obtain the  $\zeta$ -coördinate of this point on the sphere and its distance  $\rho$  from the  $\zeta$ -axis, the similar triangles  $O'\phi\pi, \pi\phi O, O'OP$  in Fig. 7 furnish the following double proportion :

$$(1 - \zeta) : \rho = \rho : \zeta = 1 : r.$$

From this it follows that

$$(2) \quad r = \frac{\zeta}{\rho} = \frac{\rho}{1 - \zeta},$$

and from these further :

$$(3) \quad r^2 = \frac{\zeta}{1 - \zeta}, \quad 1 + r^2 = \frac{1}{1 - \zeta},$$

\* Words in the parenthesis added by the translator.

and conversely :

$$(4) \quad \zeta = \frac{r^2}{1+r^2}, \quad \rho = \frac{r}{1+r^2}.$$

By construction it follows that

$$x : y : r = \xi : \eta : \rho.$$

We find therefore that

VII. *The coördinates of a point of the sphere are expressed as follows in terms of the coördinates of the corresponding point of the plane :*

$$(5) \quad \xi = \frac{x}{1+r^2}, \quad \eta = \frac{y}{1+r^2}, \quad \zeta = \frac{r^2}{1+r^2}.$$

VIII. *Conversely, the coördinates and radius vector of a point of the plane are expressed as follows in terms of the coördinates of the corresponding point of the sphere :*

$$(6) \quad x = \frac{\xi}{1-\zeta}, \quad y = \frac{\eta}{1-\zeta}, \quad r^2 = \frac{\zeta}{1-\zeta}.$$

The following theorem is obtained at once from these formulas :

IX. *To any circle of the plane there corresponds a circle of the sphere, and conversely.*

For, to the points of the plane satisfying the equation of the circle

$$(7) \quad ar^2 + bx + cy + d = 0,$$

there correspond the points of the sphere whose coordinates satisfy the equation

$$(8) \quad a\zeta + b\xi + c\eta + d(1-\zeta) = 0.$$

But this is the equation of a plane and it cuts the sphere in a circle. This converse theorem, however, supposes the word "circle" (in the plane) to be taken, as in the previous paragraph, in its extended sense to include the straight line.

We now transfer the geometrical representation of complex numbers from the plane to the sphere:

X. *We assign to each point of the sphere the same complex number  $z = x + iy$  which heretofore belonged to its stereographic projection on the plane.*

Thus to the real numbers and the pure imaginaries, for example, there correspond on the sphere the points on the "meridians"  $\eta = 0$  and  $\xi = 0$  respectively; to the points of absolute value 1, there correspond the points on the "equator"  $\zeta = 1/2$ . To opposite complex numbers (IV, § 2) correspond points of the sphere which are symmetrical to the  $\zeta$ -axis, and to conjugate complex numbers (VIII, § 4) correspond points symmetrical to the  $\xi\zeta$ -plane. To the number  $\infty$  introduced in § 12 there corresponds on the sphere, just as to any other complex number, one and only one point, viz.  $O'$ .

By means of this interpretation of complex numbers on the sphere we can now answer the question as to what transformations of the sphere (instead of the plane) into itself are represented by the functions heretofore investigated. The functions discussed in §§ 8-10 furnish nothing simpler for the sphere than for the plane. However, it is different with the function  $z' = \frac{1}{z}$  of § 11. Let  $(x, y)$  and  $(x', y')$  be two points of the plane which correspond to each other by the transformation by reciprocal radii in reference to the unit circle; and let  $(\xi, \eta, \zeta)$  and  $(\xi', \eta', \zeta')$  be respectively their stereographic projections on the sphere. Then substitute in equations (2), § 11, the values of  $x, y, r^2$  and  $x', y', r'^2$  respectively from equations (6) of the present paragraph and from the corresponding equations with accented letters, and we obtain:

$$\frac{\xi'}{1 - \zeta'} = \frac{\xi}{\zeta}; \quad \frac{\eta'}{1 - \zeta'} = \frac{\eta}{\zeta}; \quad \frac{\zeta'}{1 - \zeta'} = \frac{1 - \zeta}{\zeta};$$

from these it follows that

$$(9) \quad \xi' = \xi, \eta' = \eta, \zeta' - \frac{1}{2} = -(\zeta - \frac{1}{2}),$$

that is :

XI. *The transformation by reciprocal radii in reference to the unit circle in the plane corresponds, by stereographic projection on the sphere, to a reflection on the equatorial plane  $\zeta - 1/2 = 0$ .*

The transformation of the plane into itself by means of  $z' = z^{-1}$  is performed by first transforming by reciprocal radii in reference to the unit circle and then reflecting on the axis of real numbers. The corresponding transformation of the sphere into itself is thus performed by two reflections, one on the equatorial plane and the other on the meridian plane  $\eta = 0$ . Now these two reflections on the two planes perpendicular to each other are compounded by merely "Reflecting on the line of intersection of the two planes," that is, by taking for each point another one symmetrical to the first in reference to the line of intersection. This transformation is performed also by rotating the sphere through  $180^\circ$  about this line of intersection as an axis. Hence, we state the following theorem :

XII. *The transformation  $z' = z^{-1}$  determines a rotation of the sphere through  $180^\circ$  about the diameter passing through the points  $z = 1$  and  $z = -1$ .*

In the plane the origin was an exception to the transformation in that there was no proper point corresponding to it. On the sphere, as we have seen, it is different, since the origin corresponds to its opposite pole  $O'$ . Hence we say :

XIII. *The transformation  $z' = z^{-1}$  is reversibly unique for all points of the sphere ; to any point  $z$  there corresponds one and only one point  $z'$ , and conversely.*

From the geometrical representation given in XII we infer further that :

XIV. *For the transformation  $z' = z^{-1}$  there are two and only two points  $z$  which coincide with their corresponding points  $z'$ , viz.  $z = 1$  and  $z = -1$ .*

We return now to the question postponed in a previous paragraph as to how the theorems of plane geometry appear in reference to the convention introduced there; it is evident that this convention amounts to regarding the plane as an infinitely large sphere and transforming the theorems of ordinary spherical geometry to the plane. We shall not go into further details here except to remark that the circles of the plane corresponding to great circles of the sphere are then characterized by the property that they cut the unit circle in the end points of a diameter.

Further: If we combine with the transformation (XII) that reflection on the  $\eta\xi$ -plane perpendicular to the diameter, which puts  $x + iy$  into  $-x + iy$ , we find:

XV. *The transformation, which replaces every point of the sphere by the one lying diametrically opposite to it, is expressed analytically by the equation:*

$$x' + iy' = -\frac{1}{x - iy}$$

or,

$$(10) \quad x' = \frac{-x}{x^2 + y^2}, \quad y' = \frac{-y}{x^2 + y^2}.$$

Two complex numbers having the relation to each other expressed in equations (10) are called *diametral*.

#### EXAMPLES

1. The sphere may be projected *stereographically* upon a plane as follows: Let the center of the sphere be taken as the origin of coördinates  $\xi, \eta, \zeta$  of a point on the sphere. Let the points of the sphere be projected from the south pole (whose coördinates are  $0, 0, -1$ ) upon the tangent plane at the north

pole and take the Cartesian axes  $ox$  and  $oy$  on the tangent plane, parallel to the axes  $\xi$  and  $\eta$  respectively. Show that the coordinates of the projected point are

$$x = \frac{2\xi}{1+\zeta}, \quad y = \frac{2\eta}{1+\zeta},$$

and that  $x + iy = 2 \tan \frac{\theta}{2} (\cos \phi + i \sin \phi)$ , where  $\phi$  is the longitude measured from the plane  $\eta = 0$  and  $\theta$  the north polar distance of the point on the sphere.

2. A circle  $4x^2 + 4y^2 - 4x - 4y + 1 = 0$  is projected upon the sphere as in Ex. 1; find the equation of the plane whose intersection with the sphere represents this projection.

3. A circle, the equation of whose plane of intersection with the sphere is

$$\xi + \eta + \zeta - 5/4 = 0,$$

is projected upon the plane as in Ex. 1; find the equation of the projection.

4. Solve Ex. 2 according to the method of projection in I, § 13.

5. Find the equation of the projected circle of Ex. 4 for the plane and sphere as in I, § 13.

#### § 14. The General Linear Fractional Function and the Circle Transformation\*

In the process of investigating rational functions of a complex variable by proceeding from simpler to more complicated forms we consider next the general linear fractional function:

$$(1) \quad z' = \frac{az + b}{cz + d}.$$

\* The transformation determined by the linear fractional function, that is, by the *linear substitution*, is called *bilinear* by some authors. On *Kreisverwandtschaft*, that is, circle transformation between the planes, see MÖBIUS: *Abhandlung der Sächs. Gesellsch. der Wissensch.*, 1855, and earlier notices on the same subject in *Gesammelte Werke*, Vol. II, p. 243. — S. E. R.

We take up first the case

$$(2) \quad ad - bc = 0, *$$

or  $a : b = c : d.$

In this case the transformation becomes

$$(3) \quad z' = \frac{a(z + b/a)}{c(z + b/a)};$$

all points  $z$ , except  $z = -b/a$ , correspond then to the one point  $z' = a/c$ , and all points  $z'$ , except  $z' = a/c$ , correspond to the one point  $z = -b/a$ . We are thus dealing with a degenerate transformation; this case is therefore excluded in what follows. We shall discuss two additional cases:

I. *In case*  $c = 0, d \neq 0,$

$z'$  reduces to the linear integral function:

$$(4) \quad z' = \frac{a}{d} \cdot z + \frac{b}{d}.$$

Since the discussion of this case is already disposed of in § 10, we omit it here.

II. *In case*

$$(5) \quad c \neq 0,$$

transformation (1) can be compounded from the following three simpler ones; we first put

$$(6) \quad z'' = z + \frac{d}{c},$$

then

$$(7) \quad z''' = \frac{1}{z''},$$

and finally

$$(8) \quad z' = \frac{a}{c} + \frac{bc - ad}{c^2} \cdot z''.$$

\* That is, the *determinant of the transformation* equals zero. — S. E. R.

The second of these is disposed of in § 11, while the first and third are similarity transformations (§ 10). All three of these relations have the property that they transform circles into circles. Hence the same property must belong to the transformation (1) compounded from them. By definition, therefore :

III. *Two planes having a one-to-one correspondence are said to be circularly transformed into each other if every circle of one plane corresponds to a circle of the other ;*

and hence the theorem :

IV. *The  $z$ -plane is transformed circularly into the  $z'$ -plane by the linear fractional function (1).*

Since each of the three transformations (6)–(8) preserves angles, the same will be true for the transformation resulting from their combination. We therefore add (cf. VII, § 11) :

V. *The representation is conformal without inversion of the angle.*

We shall call the circle transformation “direct” or “inverted” according as the sense of the angle remains the same or is changed. In the present case we are dealing with a direct circle transformation. An inverted circle transformation between the  $z$ - and the  $z'$ -planes is obtained by putting  $z'$  equal to a linear function of the value  $\bar{z}$  conjugate to  $z$ .

The set of all transformations (1) possesses an important property which must be discussed. If in addition to (1) we put also

$$(9) \quad z'' = \frac{a'z' + b'}{c'z' + d'},$$

it follows that

$$(10) \quad z'' = \frac{a''z + b''}{c''z + d''},$$

where the doubly accented coefficients are related as follows to the unaccented and singly accented ones :

$$(11) \quad \begin{array}{ll} a'' = ad' + cb' & b'' = ba' + db' \\ c'' = ac' + cd' & d'' = bc' + dd'. \end{array}$$

The conclusion therefore is that

VI. *A linear function of a linear function is itself a linear function.* But it is desirable to formulate this theorem somewhat differently by making use of an important general concept stated in the following definition :

VII. *A set of transformations is called A GROUP when the combination of any two transformations selected from the set gives always a transformation which is itself contained in the set.\**

Theorem VI therefore reads :

VIII. *The set of all linear transformations forms a group.*

(The special sets of linear transformations treated in §§ 8, 9, 10 each form a group. All these groups are contained as “sub-groups” in the group of all linear transformations.)

It is to be noticed too that the transformation (1) can be compounded in various other ways from simpler transformations. (Cf. the corresponding results of § 10.) Considering the  $z$ - and the  $z'$ -planes coincident, let us next inquire about the *fixed points of transformation (1)*, that is, those points which corre-

\* Present usage insists *further* that the set must also contain the *inverse* of every transformation of the set in order that it may be a group. ( $z' = z + a$ ,  $a$  real and  $> 0$ , satisfies the definition according to VII, but is not a group.) The inverse transformation is defined as follows: Given a transformation  $A$  and suppose  $A'$  another transformation such that when  $A$  and  $A'$  are performed successively *each point is transformed into itself*, that is, the *identical transformation* is obtained, then  $A'$  is called the *inverse* of  $A$ . This is denoted symbolically by  $A \cdot A^{-1} = A^{-1} \cdot A = I$  where  $I$  is the identical and  $A^{-1}$  is the inverse transformation of  $A$ . Cf. IIa, § 22.  
—S. E. R.

spond to themselves by this transformation and in the determination of which we put  $z = z'$ . We thus obtain the following equation of the second degree :

$$(12) \quad cz^2 + (d - a)z - b = 0.$$

If the roots of this equation,  $\zeta_1, \zeta_2$ , are different, we form the following linear function of  $z'$  :

$$(13) \quad Z = \frac{z' - \zeta_1}{z' - \zeta_2}.$$

According to VI this is a linear function of  $z$  which can be computed. We shall effect our purpose more directly, however, as follows: For  $z = \zeta_1$ , we have  $z' = \zeta_1$  and  $Z = 0$ ; for  $z = \zeta_2$ ,  $z' = \zeta_2$  and  $Z = \infty$ . But a linear function of  $z$  which becomes zero for  $z = \zeta_1$  and infinite for  $z = \zeta_2$  must be of the form

$$Z = k \cdot \frac{z - \zeta_1}{z - \zeta_2},$$

where  $k$  is a factor to be determined. This may be done by noticing that for  $z = 0$ ,  $z' = b/d^*$  and therefore

$$\frac{b - d\zeta_1}{b - d\zeta_2} = k \cdot \frac{\zeta_1}{\zeta_2};$$

hence

$$(14) \quad k = \frac{\zeta_2}{\zeta_1} \cdot \frac{b - d\zeta_1}{b - d\zeta_2} = \frac{a - c\zeta_1}{a - c\zeta_2}.$$

(The last form of this result is obtained from the fact that  $\zeta_1$  and  $\zeta_2$  both satisfy equation (12).) We have thus found that

IX. If the roots of equation (12) are unequal, relation (1) between  $z$  and  $z'$  may be put in the form :

$$(15) \quad \frac{z' - \zeta_1}{z' - \zeta_2} = \frac{a - c\zeta_1}{a - c\zeta_2} \cdot \frac{z - \zeta_1}{z - \zeta_2}.$$

\* Any other pair of corresponding values of  $z$  and  $z'$  must naturally give the same result; thus for  $z = -d/c$ ,  $z' = \infty$ .

But if the roots of equation (12) are equal, both =  $\zeta$ , we form the function

$$(16) \quad Z = \frac{1}{z' - \zeta}.$$

This is then a linear function of  $z$  which is infinite for  $z = \zeta$  and hence must be of the form :

$$\frac{\alpha z + \beta}{z - \zeta}.$$

The coefficients  $\alpha, \beta$  may be determined from the fact that the equation :

$$(\alpha z + \beta - 1)(z - \zeta) = 0,$$

resulting from

$$\frac{1}{z' - \zeta} = \frac{\alpha z + \beta}{z - \zeta}$$

for  $z' = z$ , must be identical with equation (12), and likewise that  $\zeta$  must be a double root ; therefore

$$(\alpha \zeta + \beta - 1) = 0,$$

and  $Z$  takes the form :

$$\frac{1}{z - \zeta} + \alpha.$$

Here again  $\alpha$  is determined from any two corresponding values of  $z$  and  $z'$ , the simplest of which are  $z = \infty, z' = a/c$ . Thus

$$\alpha = \frac{c}{a - c\zeta},$$

or, since  $\zeta = \frac{a-d}{2c}$  in this case,

$$(17) \quad \alpha = \frac{2c}{a+d}.*$$

\*  $\alpha$  may also be obtained as follows :

$$\frac{1}{z' - \zeta} = \frac{1}{\frac{\alpha z + \beta}{c\alpha + d} - \zeta} = \frac{\frac{c}{a - c\zeta}z + \frac{d}{a - c\zeta}}{z + \frac{b - d\zeta}{a - c\zeta}}; \text{ but this is of the form } \frac{\alpha z + \beta}{z - \zeta},$$

since  $\frac{b - d\zeta}{a - c\zeta} = -\zeta$  from (12). It follows that  $\alpha = \frac{c}{a - c\zeta} = \frac{2c}{a + d}$ . — S. E. R.

Therefore,

X. If the roots of equation (12) are equal, both =  $\zeta$ , the relation (1) between  $z$  and  $z'$  may be put in the form

$$(18) \quad \frac{1}{z' - \zeta} = \frac{1}{z - \zeta} + \frac{2c}{a + d}.$$

The equations (15) and (18) permit of a simple geometrical interpretation. To interpret equation (15), put

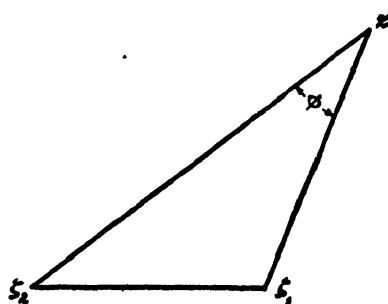

FIG. 8

$$\frac{z - \zeta_1}{z - \zeta_2} = \rho(\cos \phi + i \sin \phi)$$

$$\frac{z' - \zeta_1}{z' - \zeta_2} = \rho'(\cos \phi' + i \sin \phi')$$

$$k = m(\cos \psi + i \sin \psi).$$

It therefore follows from equation (15) that

$$(19) \quad \rho' = m\rho, \quad \phi' = \phi + \psi.$$

Now (cf. II, § 7)  $\rho$  is the ratio of the two lengths  $\overline{z\zeta_1}$  and  $\overline{z\zeta_2}$ ,  $\phi$  is the angle  $\zeta_2 z \zeta_1$ . From elementary geometry, the geometrical locus of the points for which

$$(20) \quad \rho = \text{const.}$$

is a circle whose center lies on the line connecting  $\zeta_1$  and  $\zeta_2$  and which has the property that  $\zeta_1$  and  $\zeta_2$  can be obtained from each other by the transformation by reciprocal radii in reference to this circle. The locus of the points for which

$$(21) \quad \phi = \text{const.}$$

is a circle through  $\zeta_1$  and  $\zeta_2$ . Therefore,

XI. Transformation (15) transforms each of the two systems of circles (20) and (21) into itself. All points of a circle  $\rho = a$  (or of

a circle  $\phi = \alpha$ ) are transformed respectively into points of the circle  $\rho' = ma$  (or  $\phi' = \alpha + \psi$ ) belonging to the same system.

Let us notice the two special cases  $m = 1$  (that is,  $|k| = 1$ ) and  $\psi = 0$  or  $= \pi$  (that is,  $k$  real).

XII. *In the first of these special cases each circle of the first system is transformed into itself, and in the second case each circle of the second system is transformed into itself.*

An important property of the two systems (20) and (21) is that

XIII. *Every circle of the one system cuts every circle of the other system at right angles.*

This is proved either by elementary geometry or as follows:

The two given systems are transformed respectively by the linear transformation

$$Z = \frac{z - \zeta_1}{z - \zeta_2},$$

into the system  $|Z| = \text{const.}$ , that is, into the system of concentric circles about the origin, and into the system  $amZ = \text{const.}$ , that is, into the system of straight lines through the origin. But both of these systems are orthogonal to each other; and since by (V) a linear transformation leaves angles unchanged, the two first-named systems are also orthogonal to each other.

The special case (X) follows from the general one (IX) by a suitable limiting process. If we allow the point  $\zeta_1$  to approach the point  $\zeta_2$  in a given direction, then the system of circles through  $\zeta_1$  and  $\zeta_2$  goes over into the system of circles through  $\zeta_2$  and having at this point the given direction for the direction of the tangents; the system of circles which have their centers on the line  $\overline{\zeta_1\zeta_2}$  and divide the line segment  $\overline{\zeta_1\zeta_2}$  harmonically are transformed into the system of circles which pass through  $\zeta_2$  and whose centers lie on the common tangent of the circles of the

first system, and which have also at  $\zeta_2$  a common tangent perpendicular to the common tangent of the first system.

Analytically, this limit is determined as follows: put

$$\zeta_2 = \zeta, \quad \zeta_1 = \zeta - \delta, \quad \frac{c}{a - c\zeta} = \alpha;$$

equation (15) now takes the form:

$$(22) \quad 1 + \frac{\delta}{z' - \zeta} = (1 + \alpha\delta) \left( 1 + \frac{\delta}{z - \zeta} \right).$$

Multiply out, cancel 1 on each side, divide by  $\delta$ , and then let  $\delta$  approach zero; equation (18) is the result. In this process the direction in which  $\zeta_1$  approaches  $\zeta_2$  is left entirely undetermined. Therefore (as an indirect result from the first geometrical process) we always obtain the same special transformation (18) from the general one (15) in whatever direction  $\zeta_1$  approaches  $\zeta_2$ . It is to be noticed also that while we found for each such limit process just two systems of circles which are transformed into themselves by (18), there are others having this property; in fact the conclusion is evident that *every* system of circles through  $\zeta$  having a common tangent is transformed into itself by (18).

To show this analytically let us again put

$$\begin{aligned} \frac{1}{z - \zeta} &= Z = X + iY, \\ \frac{1}{z' - \zeta} &= Z' = X' + iY', \\ \alpha &= \beta + i\gamma, \end{aligned}$$

so that equation (18) reduces to the two following ones:

$$(23) \quad X' = X + \beta, \quad Y' = Y + \gamma;$$

from these it follows that

$$(24) \quad (\lambda X' + \mu Y') = (\lambda X + \mu Y) + (\lambda\beta + \mu\gamma),$$

that is, every system of straight lines

$$(25) \quad \lambda X + \mu Y = \text{const.}$$

is transformed into itself by (18). But, in the  $Z$ -plane, equation (25) represents a system of parallel straight lines; by the transformation

$$z - \zeta = \frac{1}{Z},$$

this system is transformed, according to Va, § 11, into circles with a common tangent at the point  $\zeta$ . Consequently all systems of this kind are transformed into themselves by (18). It follows therefore that:

XIV. *There are infinitely many systems of circles each of which is transformed into itself by the special transformation (18): that is, every system of circles through  $\zeta$  with a common tangent has this property.*

However:

XV. *Among these systems there is one such that any circle belonging to it is transformed into itself.*

We obtain this last system by choosing  $\lambda$  and  $\mu$  in (24) so that

$$\lambda\beta + \mu\gamma = 0.$$

#### EXAMPLES

1. Prove that the general linear fractional transformation transforms circles into circles starting from the fact that  $(z - \alpha)/(z - \rho) = \lambda$  is the  $z$ -circle and then substituting for  $z$  its value in terms of  $z'$ .

2. What is the condition that the transformation

$$z' = \frac{az + b}{cz + d}$$

transforms the unit circle in the  $z'$ -plane into a straight line?

*Ans.*  $|a| = |c|$ .

3. If the invariant points for the transformation

$$z' = \frac{az + b}{cz + d}$$

are  $\alpha, \beta$  show that it can be put in the form

$$\frac{z' - \alpha}{z' - \beta} = k \frac{z - \alpha}{z - \beta}.$$

4. Find the invariant points for the transformation

$$z' = \frac{1 + z}{1 - z}.$$

Put it in the form given in Ex. 3.

5. Prove the statement in the text which says that the geometrical locus of the points for which  $\rho = \text{const.}$  (equation 20, § 14) is a circle.

6. Discuss the transformation (1) by putting it in the form

$$z' - \frac{a}{c} = - \frac{(ad - bc)}{c^2 \left( z + \frac{d}{c} \right)}.$$

Transform the origins in the  $z'$ - and the  $z$ -planes into the points  $a/c$  and  $-d/c$  respectively. A  $z'$ -locus is therefore obtained from a  $z$ -locus by transferring the origin to  $-d/c$ , turning the plane through two right angles about the line  $z = \frac{1}{2} \text{am} \left( \frac{bc - ad}{c^2} \right)$ , inverting the locus in the new position with a constant of inversion equal to  $\left| \frac{bc - ad}{c^2} \right|$ , and finally moving the origin to the point  $-a/c$ .

7. Show by the process in Ex. 6 that a circle is transformed into a circle by the transformation (1).

8. Show from the particular form used in Ex. 6 that the bilinear transformation is equivalent to two inversions in space.

9. Show *geometrically* that the bilinear transformation is equivalent to two inversions in space.

[HARKNESS AND MORLEY, *Introduction*, etc. p. 42.]

10. Prove that the determinant of the product of two linear transformations equals the product of the determinants of the two transformations (understanding the product of two transformations to be the result of performing them successively).

### § 15. The Double Ratio Invariant under the Linear Transformation

In § 10 we saw that two given  $z$ -points can be transformed into two given  $z'$ -points by a "similarity" transformation  $z' = az + b$ ; the two constants  $a$ ,  $b$  at our disposal are determined according to the conditions of the problem.

The general type of linear fractional transformation (I, § 14) appears at first to contain four arbitrary constants, but there are really only three. For,

I. *If we multiply the four coefficients  $a$ ,  $b$ ,  $c$ ,  $d$  by the same factor  $m$ , the linear transformation remains unchanged; it depends therefore not upon four, but upon three arbitrary constants independent of each other.*

(If we put  $m$  equal to the reciprocal of one of the coefficients, unity takes the place of this coefficient, and the formula appears with only three constants in it. But in so doing we must exclude that transformation for which this coefficient is equal to zero.)

It is therefore always possible to determine the coefficients of a linear transformation to satisfy three given conditions. In particular cases we should investigate whether or not these conditions are contradictory among themselves. If, for example, it is required to determine the linear transformation

which transforms three given distinct points  $z_1, z_2, z_3$  into three other given points, we have the three equations

$$(1) \quad z_i' = \frac{az_i + b}{cz_i + d}, \quad (i = 1, 2, 3),$$

$$\text{or,} \quad cz_i'z_i + dz_i' - az_i - b = 0, \quad (i = 1, 2, 3).$$

These three equations are sufficient to determine the three ratios of the four coefficients. As shown in the theory of determinants (A. A. § 31) it is always possible to determine these ratios for equations (1), and in fact in only one way, provided that not all of the four third order determinants of the matrix :

$$\begin{vmatrix} z_1z_1', & z_1', & z_1, & 1 \\ z_2z_2', & z_2', & z_2, & 1 \\ z_3z_3', & z_3', & z_3, & 1 \end{vmatrix}$$

are zero. But, according to equation (18), § 10,

$$\begin{vmatrix} z_1', & z_1, & 1 \\ z_2', & z_2, & 1 \\ z_3', & z_3, & 1 \end{vmatrix} = 0,$$

means that the triangles  $(z_1z_2z_3)$  and  $(z_1'z_2'z_3')$  are similar to each other; and if

$$\begin{vmatrix} z_1z_1', & z_1, & 1 \\ z_2z_2', & z_2, & 1 \\ z_3z_3', & z_3, & 1 \end{vmatrix} = 0 \quad \text{or} \quad \begin{vmatrix} z_1', & 1, & 1/z_1 \\ z_2', & 1, & 1/z_2 \\ z_3', & 1, & 1/z_3 \end{vmatrix} = 0,$$

then the  $\Delta(z_1'z_2'z_3') \sim \Delta\left(\frac{1}{z_1} \quad \frac{1}{z_2} \quad \frac{1}{z_3}\right)$ . If both are true the

$\Delta\left(\frac{1}{z_1} \quad \frac{1}{z_2} \quad \frac{1}{z_3}\right) \sim \Delta(z_1z_2z_3)$  and therefore

$$\begin{vmatrix} 1/z_1, & z_1, & 1 \\ 1/z_2, & z_2, & 1 \\ 1/z_3, & z_3, & 1 \end{vmatrix} = 0 \quad \text{or} \quad \begin{vmatrix} 1, & z_1^2, & z_1 \\ 1, & z_2^2, & z_2 \\ 1, & z_3^2, & z_3 \end{vmatrix} = 0,$$

that is,  $(z_1 - z_2)(z_2 - z_3)(z_3 - z_1) = 0$ ;

in other words, two of the  $z$ -points then coincide.\* The following theorem is therefore true:

II. *There is always one and only one linear transformation which transforms three given distinct points  $z$  into three given points  $z'$ .*

Of course, if the transformation is not degenerate ((2), § 14), the three  $z'$ -points must be distinct.

As an example of theorem II we will treat the problem to map the inside of the unit circle of the  $z$ -plane conformally upon that half of the  $z'$ -plane whose points represent complex numbers with the coefficients of  $i$  positive. For this purpose let us associate three arbitrary points of the unit circle of the  $z$ -plane with three arbitrary real values of  $z'$ ; it then follows that if, in passing over the series of values  $z_1, z_2, z_3$  upon the unit circle, we have the area of this circle to our left, then in passing over the corresponding series of values  $z_1', z_2', z_3'$  upon the real axis the given half-plane (called briefly the "positive half-plane") lies also to our left. This, for example, is the case when we set the points

$$z_1 = 1, \quad z_2 = i, \quad z_3 = -1$$

respectively in correspondence with the points

$$z_1' = 0, \quad z_2' = 1, \quad z_3' = \infty.$$

We thus obtain the equations:

$$(2) \quad \frac{a+b}{c+d} = 0, \quad \frac{ai+b}{ci+d} = 1, \quad \frac{a-b}{c-d} = \infty,$$

or,  $(a+b) = 0, \quad (b-d) = i(c-a), \quad (c-d) = 0.$

\* In this discussion  $z_1, z_2, z_3$  are understood to be different from zero. The case where one of these numbers = 0 can be brought under the general case by an auxiliary transformation of some such simple form as  $z' = z + f$ .

Since we may put  $d=1$ , it follows that  $a=-i$ ,  $b=i$ ,  $c=1$ , that is,

$$(3) \quad z' = i \cdot \frac{1-z}{1+z} \quad \text{and hence} \quad z = \frac{i-z'}{i+z'}$$

We investigate further the mapping of the  $z$ -plane upon the  $z'$ -plane by means of these formulas. To the values

$$z = 0, \quad 1, \quad i, \quad -1, \quad -i, \quad \infty$$

correspond the values

$$z' = i, \quad 0, \quad 1, \quad \infty, \quad -1, \quad -i.$$

To the  $z$ -axis of real numbers corresponds the  $z'$ -axis of pure imaginaries; to the  $z$ -axis of pure imaginaries corresponds the unit circle of the  $z'$ -plane (cf. IV, § 7). By means of these

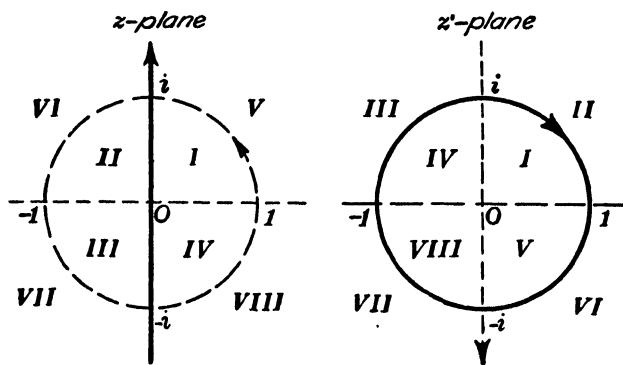

FIG. 9

given lines the two planes are each divided into eight regions (to which the octants of the sphere correspond). These regions correspond to each other as in Fig. 9.

But if *four*, instead of three, given  $z$ -points are to be transformed into four given  $z'$ -points by a linear substitution, an additional condition must be satisfied. This condition is found briefly as follows; The function of three points  $(z_1 - z_2)/(z_3 - z_2)$

already considered in § 10, equation (16), becomes, by the linear transformation (1),

$$\frac{z'_1 - z'_2}{z'_3 - z'_2} = \frac{cz_3 + d}{cz_1 + d} \cdot \frac{z_1 - z_2}{z_3 - z_2},$$

that is, it is in its original form multiplied by a factor which does not contain  $z_2$ . If we now form the quotient of this function and a corresponding one in which  $z_4$  is used instead of  $z_2$ , this factor disappears. We thus find :

$$(4) \quad \frac{z'_1 - z'_2}{z'_3 - z'_2} : \frac{z'_1 - z'_4}{z'_3 - z'_4} = \frac{z_1 - z_2}{z_3 - z_2} : \frac{z_1 - z_4}{z_3 - z_4}.$$

The following definition enables us to state this result more conveniently :

III. *The double ratio of four points  $(z_1, z_2, z_3, z_4)$  — taken in this order — is understood to be the quotient :*

$$(5) \quad \frac{z_1 - z_2}{z_3 - z_2} : \frac{z_1 - z_4}{z_3 - z_4} = (z_1, z_2, z_3, z_4);$$

therefore,

IV. *The condition for the existence of a linear transformation which transforms four given  $z$ -points into four given  $z'$ -points is, that the double ratio of the  $z$ -points shall be equal to the double ratio of the  $z'$ -points taken in the same order.*

And further :

V. *This condition is necessary and sufficient providing the four given points are distinct.*

For, when that linear transformation which puts the points  $z_1, z_2, z_3$  respectively into  $z'_1, z'_2, z'_3$  is found by II, it has the property of transforming the point  $z_4$  into  $z'_4$  providing the double ratios  $(z_1, z_2, z_3, z_4)$  and  $(z'_1, z'_2, z'_3, z'_4)$  are equal. But there is only one such point since equation (4) is of the first degree in  $z'_4$ . It must therefore be the given one, Q.E.D.

The double ratio of four complex points is of course in general complex; but more precisely:

VI. *The double ratio of four points is real when, and only when, the four points lie on a circle.*

The amplitude of  $(z_1 - z_2)/(z_3 - z_2)$  is the angle  $z_3z_2z_1$  and the amplitude of  $(z_1 - z_4)/(z_3 - z_4)$  is the angle  $z_3z_4z_1$ . If the quadrilateral  $z_1z_2z_3z_4$  is inscribable in a circle, then these two angles are inscribed angles measured by the same arc or by arcs whose sum is a whole circumference. In the first case these angles have the same sense, in the second case opposite sense. Moreover, in the first case  $\sphericalangle z_3z_4z_1 = \sphericalangle z_3z_2z_1$ , in the second case it  $= \sphericalangle z_3z_2z_1 - \pi$ . Therefore the amplitude of the double ratio is zero in the first case and  $\pi$  in the second, and the double ratio itself is real in both cases. But if the four points do not lie on a circle, then  $\sphericalangle z_3z_4z_1$  is different from  $\sphericalangle z_3z_2z_1$ , and from  $\sphericalangle z_3z_2z_1 - \pi$ , and therefore the double ratio is not real.\*

If, in particular,  $z_2 = 0$ ,  $z_3 = 1$ ,  $z_4 = \infty$ , we find that

$$(z_1, 0, 1, \infty) = z_1,$$

that is:

VII. *The double ratio of an arbitrary point  $z_1$  with the three points  $0, 1, \infty$  is equal to  $z_1$  itself.*

As already stated, the double ratio of four points depends upon the order in which the points are taken. But four points can be arranged in twenty-four different ways. Of these the following four

$$(z_1, z_2, z_3, z_4), (z_2, z_1, z_4, z_3), (z_3, z_4, z_1, z_2), (z_4, z_3, z_2, z_1)$$

\* To students acquainted with projective geometry we remark, without proving, that the double ratio of four points of a circle as here defined is exactly equal to the double ratio of four such points as defined in projective geometry: the complex double ratio defined here for four given points of the plane is equal to their double ratio upon that imaginary conic section determined by them and one of the "circular points at infinity."

give the same double ratio, as a glance at formula (5) shows; thus only six different double ratios can be formed from the same four points. However, there are simple relations connecting these six ratios. If we put

$$(6) \quad (z_1, z_2, z_3, z_4) = \lambda,$$

it follows at once that

$$(7) \quad (z_1, z_4, z_3, z_2) = 1/\lambda.$$

Simple calculation shows further that

$$(8) \quad (z_1, z_3, z_2, z_4) = 1 - \lambda;$$

and, by combination of these two results,

$$(9) \quad (z_1, z_3, z_4, z_2) = 1 - (z_1, z_4, z_3, z_2) = 1 - \frac{1}{\lambda} = \frac{\lambda - 1}{\lambda},$$

$$(10) \quad (z_1, z_2, z_4, z_3) = \frac{1}{(z_1, z_3, z_4, z_2)} = \frac{\lambda}{\lambda - 1},$$

$$(11) \quad (z_1, z_4, z_2, z_3) = 1 - (z_1, z_2, z_4, z_3) = \frac{1}{1 - \lambda}.$$

It thus follows that :

VIII. *Each of the six double ratios which can be formed from four points is a linear function of each of the others.*

The six values (6)-(11) are in general all different from each other. Two or more of them can be made equal only for particular values of  $\lambda$ . Closer investigation shows that all the possible cases can be made to depend upon the two following types by a change of symbol :

$$(12) \quad \lambda = \frac{1}{\lambda} = -1, \quad \frac{1}{1 - \lambda} = \frac{\lambda}{\lambda - 1} = \frac{1}{2}, \quad 1 - \lambda = \frac{\lambda - 1}{\lambda} = 2$$

and

$$(13) \quad \begin{cases} \lambda = \frac{1}{1 - \lambda} = \frac{\lambda - 1}{\lambda} = \frac{1 + i\sqrt{3}}{2} \\ \frac{1}{\lambda} = 1 - \lambda = \frac{\lambda}{\lambda - 1} = \frac{1 - i\sqrt{3}}{2} \end{cases}$$

IX. In case (12) we call the four points "harmonic," in (13) they are called "equianharmonic."\*

For example,  $-1, 0, 1, \infty$  are four harmonic points; also the four vertices of a square; the three vertices of an equilateral triangle and the center of its circumscribed circle are four equianharmonic points (or upon the sphere, the vertices of a regular tetraedron).†

Equation (4) may now be expressed by means of a term which is important in other respects. For this purpose we define:

X. A function of one or more points which remains unchanged when one and the same arbitrary transformation of a given group is applied to all of the points is called an invariant of the group.

Thus equation (4) expresses the fact that

XI. The double ratio of four points is an invariant of the group of linear transformations.‡

We can assert further that it is the *only* invariant of this group. This is to be understood as follows: *Three* points can have no invariant of this group on account of theorem II. The equality of the double ratio of two sets of *four* points each is a sufficient condition for the existence of a linear transformation which transforms the one set into the other. Any other function of four points, invariant under the linear transformation, must therefore have for all sets the same value for the same double ratio. Hence it is expressed only by this double ratio

\* That is, if  $\lambda = 1$  the six ratios reduce to  $1, 0, \infty$ ; if  $\lambda = -1$  they reduce to  $-1, 1/2, 2$ ; if  $\lambda = \omega$  they reduce to  $\omega$  or  $\omega^2$  where  $\omega$  is a primitive cube root of unity. — S. E. R.

† Also the four points  $OPQR$  are harmonic when made by any chord of a conicoid drawn through a point  $O$  to intersect the surface in  $P$  and  $Q$  and the polar plane of  $O$  in  $R$ . — S. E. R.

‡ The theorem that a double ratio is unchanged by a bilinear transformation was stated by MÖBIUS, *Ges. Werke*, Vol. II. — S. E. R.

and accordingly is not counted as a new invariant. But there is no new invariant for *more than four* points. That is, suppose  $F(z_1, z_2, \dots, z_n)$  to be a function of  $n$  ( $\geq 4$ ) points invariant under the group of linear transformations. In place of  $n - 3$  points,  $z_4, z_5, \dots, z_n$ , let us put the  $n - 3$  double ratios which are formed by the remaining three points,  $z_1, z_2, z_3$ , with each of these  $n - 3$  points.  $F$  is then a function of the  $n - 3$  double ratios and of  $z_1, z_2, z_3$ . If now it is an invariant, it must take on the same value for pairs of sets of  $n$  points:  $z_1, z_2, \dots, z_n$  and  $z_1', z_2', \dots, z_n'$  which are set in correspondence by the linear transformation (1). But since the  $n - 3$  double ratios take on the same value for every pair of sets, either a relation between  $z_1, z_2, z_3$  and  $z_1', z_2', z_3'$  must remain or  $F$  must be a function of the  $n - 3$  double ratios alone. The first is impossible on account of theorem II, and hence  $F$  is expressed by the  $n - 3$  double ratios.

### EXAMPLES

1. What is the most general algebraic relation between  $z$  and  $z'$  which gives a one-to-one correspondence between the points of the  $z$ - and the  $z'$ -planes?
2. Determine the linear fractional transformation which puts the points  $z = -1, 0, 2$  respectively into the points  $z' = 0, 1, \infty$ .
3. Determine as in Ex. 2 the relation which transforms  $1, i, 3$  respectively into  $0, 1, \infty$ .
4. What relation between  $z$  and  $z'$  will transform the cube roots of unity  $1, \omega, \omega^2$  respectively into  $0, 1, \infty$ ?
5. Where is the point  $z'$  corresponding to  $z = -d/c$  by the transformation  $z' = (az + b)/(cz + d)$ ?
6. Let  $z' = (2z + 3)/(3z - 2)$ . Show that the center of the  $z'$ -circle passing through the points corresponding, by this trans-

formation, to the points  $z = 0, i, -i$  is at the point  $z' = -\frac{5}{12}$  and its radius is  $\frac{1}{2}$ . Find also the center and radius of the  $z'$ -circle corresponding to the points  $z = 0, 2i, -2i$ ; also to  $z = i, -i, 2i$ .

7. Determine the function  $z' = f(z)$  which maps the rectangular triangle whose vertices are  $z = 0, z = 1, z = 1 + i$  on the half-plane, these three points going over respectively into the points  $z' = \infty, z' = 0, z' = 1$ . To which half-plane does this triangle correspond?

8. Determine the linear fractional transformation which transforms the points  $z = 1, z = -1, z = i$  respectively into the points  $z' = 2, z' = 0, z' = \infty$ .

9. A circle of radius  $r$  and center  $(h, k)$  in the  $z$ -plane is transformed into a circle in the  $z'$ -plane by the substitution

$$z' = (az + b)/(cz + d);$$

show that the radius of the new circle is

$$\frac{r}{\lambda} \left| \frac{ad - bc}{c^2} \right|,$$

where  $\lambda = (\rho \cos \theta + h)^2 + (\rho \sin \theta + k)^2 - r^2$  and  $\rho, \theta$  are the modulus and the amplitude respectively of  $d/c$ . Find also the coördinates of the center of this new circle.

The equation of a circle whose center is at  $(h, k)$  and radius  $r$  can be put in the form  $(z - h - ki)(\bar{z} - h + ki) = r^2$  or  $z\bar{z} + \Delta z + \bar{\Delta} \cdot \bar{z} + \gamma = 0$  where  $\Delta = -h + ki, \bar{\Delta} = -h - ki$  and  $\gamma = \Delta \cdot \bar{\Delta} - r^2$  and dashes indicate conjugate imaginaries. This equation, conversely, represents a circle when  $\Delta, \bar{\Delta}$  are conjugate imaginaries and  $\gamma$  is real. Its center is  $\left[ -\frac{(\Delta + \bar{\Delta})}{2}, i\frac{(\Delta - \bar{\Delta})}{2} \right]$  and its radius is  $(\Delta\bar{\Delta} - \gamma)^{\frac{1}{2}}$ . Now subject this circle to the transformation

$$z' = (az + b)/(cz + d)$$

01,  $z = (-dz' + b)/(cz' - a)$  and  $\bar{z} = (-\bar{d}\bar{z}' + \bar{b})/(\bar{c}\bar{z}' - \bar{a})$   
and we get the relation

$$\delta'z'\bar{z}' + \Delta'z' + \bar{\Delta}'\bar{z}' + \gamma' = 0.$$

Determine these coefficients  $\delta'$ ,  $\Delta'$ ,  $\bar{\Delta}'$ , and  $\gamma'$  and show that  $\Delta'$ ,  $\bar{\Delta}'$  are conjugate imaginaries and that  $\delta'$ ,  $\gamma'$  are real. It therefore represents a circle whose center and radius can be determined.

10. Divide the  $z$ -plane into eight regions by means of the axes and the unit circle. Find the regions in the  $z'$ -plane which correspond by the transformation  $z' = (1+z)/(1-z)$  to each of these regions. Is this transformation involutonic? Compare the unit circle and the axis of imaginaries.

11. In VI, § 15 it is shown that four points lie upon a circle *when and only when* their double ratio is real. Another form of this condition is that it is possible to choose real quantities  $a, b, c$  such that

$$\begin{vmatrix} 1 & , & 1 & , & 1 \\ a & , & b & , & c \\ z_1z_4 + z_2z_3 & , & z_2z_4 + z_3z_1 & , & z_3z_4 + z_1z_2 \end{vmatrix} = 0.$$

Observe that the transformation  $z' = 1/(z - z_4)$  is equivalent to an inversion with respect to the point  $z_4$  together with a certain reflection. If  $z_1, z_2, z_3$  lie on a circle through  $z_4$  the corresponding points  $z_1' = 1/(z_1 - z_4)$ ,  $z_2' = 1/(z_2 - z_4)$ ,  $z_3' = 1/(z_3 - z_4)$  lie on a straight line. Hence, by Ex. 23, Chap. I, we can find real quantities  $a', b', c'$  such that  $a' + b' + c' = 0$  and

$$\frac{a'}{z_1 - z_4} + \frac{b'}{z_2 - z_4} + \frac{c'}{z_3 - z_4} = 0,$$

and it follows easily that this is the given condition.

12. The set of all linear fractional transformations forms a group, since the compound of any two of them is again one of

the same kind. What is the relation between this group and the set of all the transformations represented by  $z' = z + \beta$  where  $\beta$  has all positive and negative values? Discuss in the same way  $z' = \alpha z$ , and  $z' = \alpha z + \beta$ .

13. Find the six double ratios of the points  $o, 1, \infty, z$ .

14. If the double ratio of  $z, z_1, z_2, z_3 = -\omega$ , find  $z$  ( $\omega$  is a primitive cube root of unity).

15. Prove the theorem that in inversion in space *lengths of double ratios* are preserved, that is, that the length  $(A, B, C, D)$  or  $\frac{AB}{CB} \cdot \frac{CD}{AD}$  is equal to the length  $(A', B', C', D')$  or  $\frac{A'B'}{C'B'} \cdot \frac{C'D'}{A'D'}$ .

Invert the points with reference to a sphere. Since  $OA \cdot OA' = OB \cdot OB'$ , the triangles are similar and hence  $OA : OB : AB = OB' : OA' : A'B'$ . Therefore

$$A'B' = AB \cdot \frac{OB'}{OA} = AB \cdot \frac{OA' \cdot OB'}{OA \cdot OA' = r^2}.$$

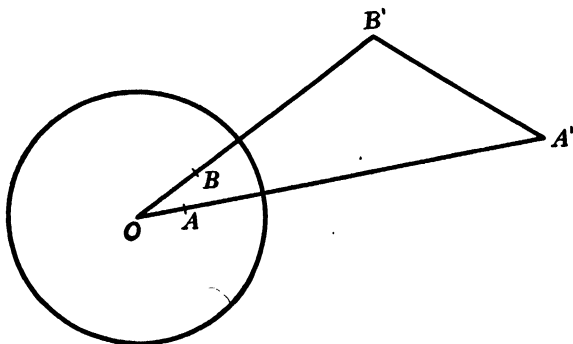

Similarly for  $A'D', C'B'$ , and  $C'D'$ ; then substitute these values in the expression for the length  $(A', B', C', D')$ , reducing finally to the expression for the length  $(A, B, C, D)$ .

**16.** Prove that any rotation of NEUMANN'S sphere about any diameter as an axis corresponds to a linear fractional transformation in the plane tangent at the origin.

Consider four points projected stereographically before and after the rotation; consider also the double ratio of these four points, using the theorem of Ex. 15. Let the points  $a, b, c, z$  project into  $a', b', c', z'$  and  $A, B, C, Z$  into  $A', B', C', Z'$ ; at the conclusion solve for  $z'$  as a linear fractional function of  $z$ .

**17.** In IX, § 15, the double ratio of four points  $z_1, z_2, z_3, z_4$  is called "harmonic" when it is equal to  $-1$ . Show that in this case  $z/(z_1 - z_3) = 1/(z_1 - z_2) + 1/(z_1 - z_4)$ . Why is it called "harmonic"?

**§ 16. Significance of the Linear Transformation on the Sphere; Collineations of Space Corresponding to It**

We will interpret the results of § 14 further by stereographic projection on the sphere. The circles of the plane which pass through the points  $\zeta_1, \zeta_2$  correspond to the circles through the corresponding points on the sphere, or otherwise expressed: they correspond to the curves of intersection made by the planes of a sheaf of planes whose axis cuts the sphere in these two points. But there are also circles on the sphere cut out by a sheaf of planes that correspond to the system of circles represented by equation (20), § 14 (the difference being merely that in this case the axis of the sheaf does not cut the sphere). This is evident from the following:

Let us draw planes tangent to the sphere at all points of a circle of the sphere; they thus envelop a right circular cone; the vertex of this cone is called the pole of the plane of this circle with respect to the sphere. Any element of the cone is at right angles to the tangent to this circle at its point of contact and thus coincides with the tangent to those circles of the

sphere which cut the first at right angles at this point. Thus the plane of each such circle must contain this element of the cone and thus, too, the vertex of the cone, the pole of the first circle. The plane of every circle which cuts two given circles of the sphere at right angles contains accordingly the poles of the planes of both circles and thus, too, the line connecting them. The proof thus follows in consideration of XIII, § 14. Hence we may say :

I. *Every linear transformation whose fixed points are distinct transforms into themselves two systems of circles on the sphere, each of which results from the intersection of a sheaf of planes with the sphere.*

We can now think of a definite transformation of space into itself as corresponding to every such transformation of the sphere into itself, by which every plane which intersects the sphere (of course in a circle) is transformed into another plane which intersects the sphere in the circle corresponding to the first. Since all the circles through two points  $z_1, z_2$  correspond to the circles through the corresponding points  $z_1', z_2'$ , it follows that: to all the planes which intersect in a straight line cutting the sphere, correspond the planes of a second such sheaf. Further, since all the circles which intersect two given circles at right angles correspond to circles which intersect the two corresponding circles at right angles (from V, § 14), it follows also as was just proved that: to all the planes of a sheaf whose axis does not intersect the sphere, correspond the planes of a second such sheaf. In this way, therefore, all the straight lines in space are arranged in pairs. And since the theorem holds that, when several straight lines not all in the same plane are arranged in pairs, they all go through the same point, it follows that all straight lines through a point correspond again to straight lines

through a point. By this transformation the planes of space, and thus the points of space as well, are set in a correspondence reversibly unique. A transformation of this kind is called a collineation; accordingly, we can write:

II. *To each linear transformation of the complex variable  $z$  on the sphere there corresponds a collineation of space, which transforms the points of the sphere precisely in the same way.*

According to theorem I, this collineation in the general case belongs to that particular kind which transforms into themselves two straight lines, two real points of one of these straight lines (viz. its points of intersection with the sphere), and two real planes through the other straight line (the planes through it tangent to the sphere). In the special case (XIV, XV, § 14) a real point of the sphere, each tangent at this point and each plane through a definite one of these tangents, is transformed into itself.

On the basis of the formulas of §§ 13 and 14 it would not be difficult (even though cumbersome), to carry out this process analytically and thus to find the equations of the corresponding collineation for each linear transformation of  $z$ . We will do this only for that transformation which corresponds to a translation in the plane parallel to the  $x$ -axis. For this

$$z' = z + \alpha \quad (\alpha \text{ is real}), \quad \text{that is,} \quad x' = x + \alpha, \quad y' = y.$$

Accordingly we have the following results from the formulas (6), § 13, and those which are obtained from (5) by accenting all the letters:

$$(1) \begin{cases} \xi' = \frac{x'}{1+r'^2} = \frac{x+\alpha}{1+r^2+2\alpha x+\alpha^2} = \frac{\xi+\alpha(1-\xi)}{2\alpha\xi+(1+\alpha^2)(1-\xi)+\zeta'} \\ \eta' = \frac{y'}{1+r'^2} = \frac{y}{1+r^2+2\alpha x+\alpha^2} = \frac{\eta}{2\alpha\xi+(1+\alpha^2)(1-\xi)+\zeta'} \\ \zeta' = \frac{r'^2}{1+r'^2} = \frac{r^2+2\alpha x+\alpha^2}{1+r^2+2\alpha x+\alpha^2} = \frac{2\alpha\xi+\alpha^2(1-\xi)+\zeta}{2\alpha\xi+(1+\alpha^2)(1-\xi)+\zeta'} \end{cases}$$

(There are of course an infinite number of transformations of space which transform the points of the sphere as desired. The process shows that we obtain the required collineation if we do not make explicit use of the equations of the sphere, but use the formulas of § 13 exactly as found there.)

A particular case of collineation is found in the "Motions in Space," that is, in those transformations which transform each figure into one congruent to it. If we take for granted at the outset that any movement which puts a sphere into itself can be replaced, so far as the result is concerned, by a rotation of the sphere on a diameter as an axis, we can then easily determine all such movements and the linear transformations corresponding to them. To this end we return to equation (15), § 14. If this is to represent a rotation of the sphere about a diameter as an axis then first,  $\zeta_1$  and  $\zeta_2$  must be *diametral* points (XV, § 13); and second, if each of the circles  $\rho = \text{const.}$  from equation (20), § 14, which in this case are parallel circles, are to be transformed into themselves, it follows that  $m$  must = 1, that is,  $k$  must be an expression of absolute value 1. Hence if  $\alpha$  and  $\lambda$  are quantities of absolute value 1 and  $r$  a positive real number, we can put

$$\zeta_1 = r\alpha, \quad \zeta_2 = -r^{-1}\alpha, \quad \text{and } k = \lambda^2.$$

The solution of equation (15), § 14 for  $z'$  thus takes the form:

$$z' = \frac{z(r\alpha + r^{-1}\alpha\lambda^2) + \alpha^2(1 - \lambda^2)}{z(1 - \lambda^2) + (r^{-1}\alpha + r\alpha\lambda^2)};$$

or, by multiplying numerator and denominator by  $\alpha^{-1}\lambda^{-1}$ :

$$= \frac{z(r\lambda^{-1} + r^{-1}\lambda) + \alpha(\lambda^{-1} - \lambda)}{z\alpha^{-1}(\lambda^{-1} - \lambda) + (r^{-1}\lambda^{-1} + r\lambda)}.$$

Here the coefficients, apart from the sign of one of them, are conjugate to each other in pairs (for  $\lambda^{-1}$  is conjugate to  $\lambda$ ,  $\alpha^{-1}$

to  $\alpha$ , and  $r$  is real); if  $A, B, C, D$  are real numbers, we can therefore write :

$$(2) \quad z' = \frac{(A + iB)z - C + iD}{(C + iD)z + A - iB}.$$

III. Therefore a linear transformation of  $z$  can always be put in the general form (2) when it represents a rotation of the sphere about its center.\*

\* EULER'S representation of rotation about a fixed point is obtained from equation (2) of the text by introducing the space coördinates  $\xi, \eta, \zeta$ , and  $\xi', \eta', \zeta'$  by means of formulas (5) and (6) of § 13. We thus obtain :

$$x' + iy' = \frac{(Ax - By - C) + i(Bx + Ay + D)}{(Cx - Dy + A) + i(Dx + Cy - B)},$$

$$(a) \quad r^2 = \frac{(A^2 + B^2)r^2 + 2(-AC + BD)x + 2(BC + AD)y + C^2 + D^2}{(C^2 + D^2)r^2 + 2(AC - BD)x + 2(-AD - BC)y + A^2 + B^2},$$

$$1 + r^2 = \frac{(A^2 + B^2 + C^2 + D^2)(1 + r^2)}{(C^2 + D^2)r^2 + 2(AC - BD)x + 2(-AD - BC)y + (A^2 + B^2)}.$$

If we put

$$(b) \quad A^2 + B^2 + C^2 + D^2 = N,$$

it follows that

$$\frac{x' + iy'}{1 + r^2} = \frac{[(Ax - By - C) + i(Bx + Ay + D)][(Cx - Dy + A) + i(-Dx - Cy + B)]}{N(1 + r^2)}.$$

The numerator on the right-hand side is :

$$\begin{aligned} & [(AC + BD) + i(BC - AD)]r^2 + [(A^2 - B^2 - C^2 + D^2) + 2i(AB + CD)]x \\ & + [2(-AB + CD) + i(A^2 - B^2 + C^2 - D^2)]y \\ & + [-AC - BD + i(-BC + AD)]. \end{aligned}$$

Now introduce the coördinates  $\xi, \eta, \zeta$  and we obtain :

$$\begin{aligned} N(\xi' + i\eta') &= [(AC + BD) + i(BC - AD)](2\zeta - 1) \\ &+ [(A^2 - B^2 - C^2 + D^2) + 2i(AB + CD)]\xi \\ &+ [2(-AB + CD) + i(A^2 - B^2 + C^2 - D^2)]\eta, \end{aligned}$$

and by dividing into real and imaginary parts :

$$(y) \quad N\xi' = (A^2 - B^2 - C^2 + D^2)\xi + 2(-AB + CD)\eta + 2(AC + BD)(\zeta - 1/2),$$

$$(b) \quad N\eta' = 2(AB + CD)\xi + (A^2 - B^2 + C^2 - D^2)\eta + 2(BC - AD)(\zeta - 1/2).$$

And from (a) it then follows that

$$\frac{1 - r^2}{1 + r^2} = \frac{(A^2 + B^2 - C^2 - D^2)(1 - r^2) + 4(AC - BD)x - 4(AD + BC)y}{N(1 + r^2)}$$

§ 17. The Function  $z^2$ 

In the preceding paragraphs we investigated in detail linear functions of  $z$ . We now turn our attention to the function

$$(1) \quad w = z \cdot z = z^2.$$

We express  $w$  and  $z$  first in rectangular and then in polar coördinates; accordingly:

$$(2) \quad z = x + iy = r(\cos \phi + i \sin \phi),$$

$$(3) \quad w = u + iv = \rho(\cos \psi + i \sin \psi),$$

and therefore from (1), § 3, we obtain:

$$(4) \quad u = x^2 - y^2, \quad v = 2xy,$$

and from (1), § 6,

$$(5) \quad \rho = r^2, \quad \psi = 2\phi.$$

The formulas (4) determine one and only one pair of real values ( $u, v$ ) for each pair of real values ( $x, y$ ); we say:

*I. The function  $w = z^2$  is hence said to be single-valued over the entire plane.*

The construction of a point  $w$  corresponding to a definite point  $z$  is most conveniently obtained by using formulas (5); the radius vector of such a point  $w$  is to the radius vector of  $z$  as that of  $z$  is to unity, while the amplitude of  $w$  is double the amplitude of  $z$ .

To each circle ( $r = \text{const.}$ ) about the origin of the  $z$ -plane corresponds a circle ( $\rho = \text{const.}$ ) about the origin of the  $w$ -plane.

and then

$$(\epsilon) \quad N(\zeta' - 1/2) = -2(AC - BD)\xi + 2(AD + BC)\eta + (A^2 + B^2 - C^2 - D^2)(\zeta - 1/2).$$

The formulas ( $\beta$ )-( $\epsilon$ ) are precisely those due to EULER.

It is sufficient to say without proving that every linear transformation of  $x + iy$  determines a movement in space considered not from the standpoint of Euclidean geometry but from that non-Euclidean geometry for which the sphere is the fundamental surface.

If the radius of the first circle increases continuously from 0 to  $\infty$ , then the radius of the  $w$ -circle takes on all values continuously increasing from 0 to  $\infty$  (as is known from the real function  $r^2$  of the real variable  $r$ , A. A. §§ 46, 61). To each straight line  $\phi = \text{const.}$  through the origin of the  $z$ -plane, there corresponds a straight line  $\psi = \text{const.}$  through the origin of the  $w$ -plane. But the amplitude of the latter line (on account of the second one of equations (5)) takes on all values from 0 to  $2\pi$  continuously, while the amplitude of the first takes on only the values from 0 to  $\pi$ . These two results are stated in the following theorem:

II. *The positive half of the  $z$ -plane (that is, that part of the plane which includes the points  $z = x + iy$  where  $y$  is positive) is mapped continuously and uniquely upon the  $w$ -plane by means of the function  $w = z^2$ .*

And this mapping is reversely unique. For,  $\rho = r^2$  and  $\psi = 2\phi$  take on each of the above pair of values,  $\rho$  between 0 and  $+\infty$ ,  $\psi$  between 0 and  $2\pi$ , *only once* while  $r$  increases from 0 to  $+\infty$  and  $\phi$  from 0 to  $\pi$ . On the contrary, the continuity in

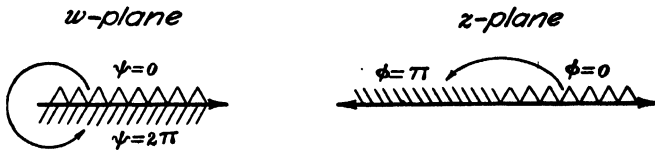

FIG. 10

this case is interrupted along the positive half of the real axis of the  $w$ -plane, inasmuch as the two sides of this positive half-axis correspond to the positive and negative parts of the real axis in the positive half of the  $z$ -plane as indicated in Fig. 10.

If  $\phi$  increases further from  $\pi$  to  $2\pi$ , then  $\psi$  takes on the values from  $2\pi$  to  $4\pi$ ; that is, the ray  $\psi = \text{const.}$  sweeps over the whole plane again so that the negative  $z$ -half-plane is also

mapped continuously and uniquely upon the  $w$ -plane. From this we therefore conclude that :

III. *The function  $w = z^2$  takes on each complex value  $w$  different from 0 and  $\infty$ , in two and only two points of the  $z$ -plane.*

Moreover, two such points are connected by the relation  $z_2 = -z_1$ ; this follows easily from the left side of the equation  $z_2^2 - z_1^2 = 0$ , the factors of which are  $z_2 - z_1$  and  $z_2 + z_1$ . We are interested in this relation particularly because it is *linear*; we define as follows :

IV. *A function  $w = f(z)$  which remains unaltered when we substitute in it a definite linear function of  $z$  in place of  $z$  is called a function with a linear transformation into itself or an automorphic function.\**

Part of theorem III may thus be stated more precisely :

V. *The function  $w = z^2$  is an automorphic function. It remains unchanged when subjected to the linear transformation of the variable :*

$$(6) \quad z' = -z.$$

Further, let us now introduce the following definition :

VI. *A region in which a single-valued function  $w$  of  $z$  takes on all of its values once and only once is called a † fundamental region for this function.*

It therefore follows from the definition of an automorphic function and of a fundamental region that :

VII. *If a fundamental region of an automorphic function is known and if it is mapped on a second region by one of the transformations of the function into itself, then this second region can*

\* A special kind of automorphic functions are the *periodic* functions. Cf. § 41, also Ex. 4 at the end of § 18, and Ex. 31 at the end of Chap. IV. — S. E. R.

† Not however "the."

nowhere overlap the first; it is also a fundamental region of the automorphic function.

Thus each of the two half-planes separated by the axis of real numbers are fundamental regions for the function  $z^2$ .

We shall continue somewhat in detail the mapping of the  $z$ -plane on the  $w$ -plane by the function  $w = z^2$ . For this purpose let us determine what curves of the  $w$ -plane correspond to the lines parallel to the axes of the  $z$ -plane. If we put  $y = c$ , equations (4) express  $u$  and  $v$  in terms of the auxiliary variable  $x$ , the elimination of which gives

$$(7) \quad u + c^2 = \left(\frac{v}{2c}\right)^2.$$

For every definite value of  $c$  this is the equation of a parabola which has the  $u$ -axis for major axis and the line  $u = -c^2$  for the tangent at the vertex. Putting the equation in the form

$$(8) \quad u^2 + v^2 = (u + 2c^2)^2,$$

we see that the origin is the focus and the line  $u + 2c^2 = 0$  is the directrix. Since  $c$  is essentially real and  $c^2$  therefore positive, the directrix crosses the negative half of the  $u$ -axis, and the parabola stretches to infinity toward the right. The focus and the major axis are independent of  $c$ . Parabolas with the same focus and the same major axis are called confocal. We put these results in the following form:

VIII. *The straight lines of the  $z$ -plane parallel to the  $x$ -axis are transformed by the function  $w = z^2$  into a system of confocal parabolas which have the origin for focus and the  $u$ -axis for major axis and which open in the direction of positive  $u$ .*

Moreover, if we put  $x = c$  in equations (4) and eliminate  $y$ , we obtain:

$$(9) \quad (c^2 - u) = \left(\frac{v}{2c}\right)^2,$$

or,

$$(10) \quad u^2 + v^2 = (u - 2c^2)^2,$$

that is :

IX. *The parallels to the  $y$ -axis are transformed into parabolas which have the same focus and the same major axis as those in VIII, but which open in the direction of negative  $u$ .*

In general, it can be shown that any straight line of the  $z$ -plane which does not go through the origin is transformed into a parabola of the  $w$ -plane which has the origin for focus.

The converse question: *What curves of the  $z$ -plane map into straight lines of the  $w$ -plane?* — will be answered as follows: Let the equation of such a straight line be

$$(11) \quad au + bv + c = 0;$$

replace  $u$  and  $v$  in this equation by their values from (4); we thus obtain :

$$(12) \quad a(x^2 - y^2) + 2bxy + c = 0.$$

X. *This is the equation of a conic section, and in fact an equilateral hyperbola (since the coefficients of  $x^2$  and  $y^2$  are equal but opposite in sign) whose center is at the origin (since the terms of first degree in  $x$  and  $y$  are absent).*

Parallel straight lines (whose equations differ only in the value of  $c$ ) thus correspond to hyperbolas with the same asymptotes. Parallels to the  $u$ -axis ( $v$ -axis) correspond to hyperbolas which are asymptotic to the coördinate axes (to the bisectors of the angle between the coördinate axes, resp.).

It is important also to notice that the map determined by the function  $w = z^2$  is conformal (VII, § 11). We shall prove this most easily by using the equations (5). If

$$\phi = f(r)$$

is the equation of a curve in the  $z$ -plane in polar coördinates,

then the tangent of the angle between the curve and the radius vector is

$$r \frac{d\phi}{dr}.$$

For the corresponding curve of the  $w$ -plane we obtain

$$(13) \quad \rho \frac{d\psi}{d\rho} = r^2 \cdot \frac{2}{2} \frac{d\phi}{r dr} = r \cdot \frac{d\phi}{dr},$$

from equations (5). Thus the two angles are equal to each other\*; we conclude from this, as in VI, § 11, that the angles between any two corresponding curves are equal to each other. We say:

XI. *The function  $w = z^2$ , just as the linear functions investigated in §§ 8–16, determines a conformal representation without inversion of the angle.*

However, there is one exception to be made. Equation (13) proves nothing for the corresponding origins of the two planes, since the expressions lose their meaning at these points. As a matter of fact, we have seen at the beginning of this paragraph that the angle at the origin is doubled. Hence we must supplement theorem XI by the following corollary:

XII. *The representation is not conformal at the origin, since to each angle which has its vertex at the origin in the  $z$ -plane there corresponds an angle twice as large at the origin in the  $w$ -plane.*

### § 18. The Function $w = z^n$ , $n$ a Positive Integer

After the detailed discussion of the function  $z^2$ , the investigation of powers with arbitrary integral exponents presents no new difficulties. Let such a function be represented by

$$(1) \quad w = z^n.$$

\* Equation (13) shows only that  $\tan \psi = \tan \phi$ . — S. E. R.

As in elementary algebra this is understood to be *the product of  $n$  factors each equal to  $z$* . Introduction of rectangular coördinates furnishes convenient formulas only for small values of  $n$ . We may conclude at once from the method of formation without actual calculation that :

I. *The function  $w = z^n$  is by definition single-valued over the entire plane.*

Retaining the notation of § 17, we obtain by repeated application of (1), § 6, in polar coördinates :

$$(2) \quad \rho = r^n, \quad \psi = n\phi.$$

To each circle about the origin of the  $z$ -plane ( $r = \text{const.}$ ) there corresponds a circle about the origin of the  $w$ -plane ( $\rho = \text{const.}$ ). If we allow the radius of the former circle to increase continuously from 0 to  $\infty$ , then the radius of the latter takes on all values, continuously increasing from 0 to  $\infty$ . To each straight line  $\phi = \text{const.}$  through the origin of the  $z$ -plane, there corresponds a straight line  $\psi = \text{const.}$  through the origin of the  $w$ -plane; but the amplitude of the latter line runs continuously through all values from 0 to  $2\pi$  while that of the former takes on only the values from 0 to  $2\pi/n$ . It therefore follows that :

II. *The sector of the  $z$ -plane limited by the rays  $\phi = 0$  and  $\phi = \frac{2\pi}{n}$  is mapped continuously and uniquely upon the  $w$ -plane by the function  $w = z^n$ .*

This mapping is also reversely unique; but in this case the continuity is interrupted along the positive real axis of the  $w$ -plane in that the two sides of this axis correspond to the two lines which delimit the sector (Fig. 11).

If we let  $\phi$  further increase from  $2\pi/n$  to  $4\pi/n$ , from  $4\pi/n$

to  $6\pi/n, \dots$ , finally from  $\left(\frac{2n-2}{n}\right)\pi$  to  $2\pi$ , then the corresponding positive half of the straight line  $\psi = \text{const.}$  sweeps over the  $w$ -plane the second, third,  $\dots$ ,  $n$ th time. The  $z$ -plane can then

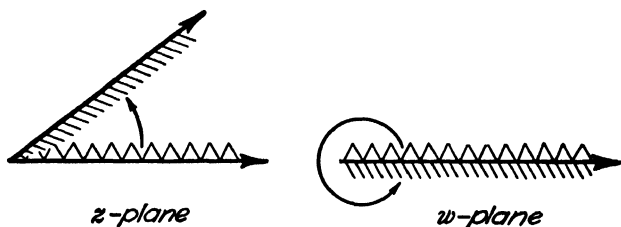

FIG. 11

be divided into sectors, each of which is mapped continuously and uniquely on the whole  $w$ -plane. It therefore follows that:

III. *The function  $w = z^n$  takes on each complex value  $w$  at exactly  $n$  points of the  $z$ -plane.*

The values  $w = 0$  and  $w = \infty$  form the only exceptions; each has an exception at just one point, viz.  $z = 0$  and  $z = \infty$  respectively. All the sectors of the  $z$ -plane have these two points in common.

There is a simple relation connecting the different points  $z$  which give the same value of  $w$ . To exhibit this relation, let us designate by  $\epsilon$  the (definite) complex number

$$(3) \quad \epsilon = \cos(2\pi/n) + i \sin(2\pi/n),$$

which has the property (cf. I, § 6) that

$$(4) \quad \epsilon^n = 1,$$

while the lower powers  $\epsilon, \epsilon^2, \epsilon^3, \dots, \epsilon^{n-1}$  are all different from each other and from 1. It then follows from the commutative law of multiplication that:

$$(5) \quad (\epsilon^k \cdot z)^n = z^n,$$

in which  $k = 1, 2, \dots, n-1$ . This result, on the basis of definition IV, § 17 is stated as follows:

IV. *The function  $w = z^n$  is an automorphic function; it remains unchanged when subjected to the linear transformations of the variable:*

$$(6) \quad z' = \epsilon^k \cdot z \quad \text{where } k = 1, 2, \dots, n.$$

Since the following theorem, resulting directly from the definition of an automorphic function, is entirely general, we can find relations connecting these  $n$  transformations:

V. *When an automorphic function  $f(z)$  remains unchanged under two linear transformations of the variable,  $z' = \phi_1(z)$  and  $z' = \phi_2(z)$ , it also remains unchanged under the linear transformations  $z' = \phi_1[\phi_2(z)]$  and  $z' = \phi_2[\phi_1(z)]$  compounded from them.*

By means of the definition of a group of transformations (VII, § 14), this theorem is stated as follows:

VI. *The linear transformations of the variable under which an automorphic function remains unchanged always form a group.*

The application of this to our example is simple: If we put  $z' = \epsilon^k \cdot z$  and  $z'' = \epsilon^l \cdot z'$ , it follows that  $z'' = \epsilon^{k+l} \cdot z$ , which likewise comes under (6) on account of (4). Moreover, we can make a still more precise statement about the structure of this group; we see that all the linear transformations belonging to the group can be obtained by repetition of the first transformation. Hence the definition:

VII. *A group, all of whose operations can be formed by repetition of a definite one of them, is called cyclic;\**

and we have thus the theorem:

VIII. *The function  $w = z^n$  determines a cyclic group of linear transformations.*

\* A cyclic group of transformations is a transformation with all of its powers, positive and negative.—S. E. R.

Theorem II may also be stated as follows :

IX. *The sector of the  $z$ -plane limited by the rays  $\phi = 0$  and  $\phi = 2\pi/n$  is a fundamental region for the  $w$ -plane.*

We shall next take up the question passed by in the above paragraphs as to how far such a fundamental region is really arbitrary. Evidently we can take away an arbitrary section from one of its borders, providing we add the corresponding section to the other border. The origin must always remain on the boundary since each transformation of the group transforms it into itself and thus the  $n$  fundamental regions have this point in common in whatever way the first fundamental region is chosen. Moreover, the fundamental region must always extend to infinity. But we can bound it on one side by an arbitrary curve running from the origin to infinity providing this curve is not intersected by the curve obtained from the first one by turning it about the origin through the angle  $2\pi/n$  (cf. Fig. 12). Among all such curves which ones shall we now choose as the best suited to bound the fundamental region?

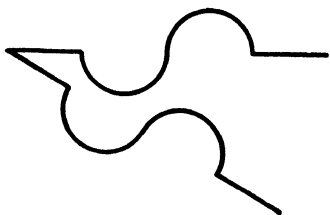

FIG. 12

There is in fact no general answer to this question for all automorphic functions. But the function  $w = z^n$  belongs to a special class of such functions for which this question can be definitely answered. It has the property that *two conjugate complex values of the function belong to every pair of conjugate complex values of the argument; in particular, real values of the function belong to real values of the argument.* Thus, when we take a region in the  $z$ -plane which is mapped by the function  $w = z^n$  on that  $w$ -half-plane with imaginary part positive, or “the

positive  $w$ -half-plane," then a region symmetrical to that one with reference to the  $x$ -axis is mapped on "the negative  $w$ -half-plane." Hence we can construct a fundamental region in the following manner: locate first all those lines to which the parts of the  $w$ -axis of reals correspond; for the present case they are the  $2n$  rays  $\phi = k\pi/n$  (where  $k = 0, 1, 2, \dots, 2n - 1$ ); these lines divide the  $z$ -plane into a certain number of regions. In each such region the sign of the imaginary part of  $w$  is constant. For, on account of the continuity,\* it can only change its sign when it passes through zero, and this according to hypothesis is the case only on the boundary of the region. Moreover, every such region for which, for example, the imaginary part of  $w$  is positive, is mapped on

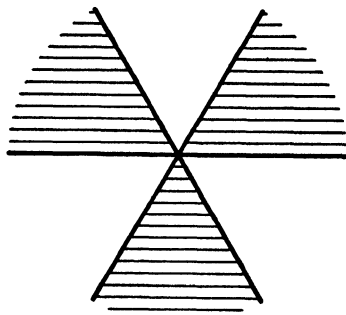

FIG. 13

the whole positive half-plane of  $w$ . For, if it were mapped on only a part of this half-plane, its boundaries, on account of the continuity, would have to be mapped on the boundaries of this part, which is contrary to the hypothesis. The  $z$ -plane, then, is divided into  $2n$  half-regions. In the case at hand these are alternately congruent and symmetrical; in more general cases direct and inverted circle transformation is used resp. in place of congruent and symmetrical. Any two of these regions adjacent to each other make up a fundamental region answering all of the conditions. Accordingly:

X. *An automorphic function which takes on conjugate values of the function at conjugate points is called a symmetric automorphic function.*

\* The question of continuity is taken up again in detail in § 31.

XI. To a symmetric automorphic function corresponds a division of the  $z$ -plane into alternate regions determined resp. by direct and inverted circle transformations. These regions are such that any two of them adjacent to each other form a fundamental region for the function.

XII. In the case of the function  $w = z^n$ , these half-regions are sectors bounded by straight lines making angles of  $\pi/n$  with each other.

### EXAMPLES

1. The function  $f(z) = (z^2 - z + 1)^3 / (z^2 - z)^2$  is unaltered by any of the transformations of its variable given by the six substitutions of the group  $z, 1/z, 1-z, 1/(1-z), (z-1)/z, z/(1-z)$ . It is therefore an automorphic function. This group is also finite discontinuous (cf. § 22).

2. Show that  $1, A(z) = \omega(z), B(z) = \omega^2(z)$  (where  $\omega$  is a primitive cube root of unity) form a cyclic group of order 3 (where the *order* of the group is defined as the number of transformations contained in the group).

3. Show that the following transformations form a group:

$$A_k(z) = z + k, \quad A_k^2(z) = z + 2k, \quad A_k^3(z) = z + 3k, \\ \dots, \quad A_k^n(z) = z + nk, \text{ etc.,}$$

where  $n = 0, \pm 1, \pm 2, \dots, \pm \infty$ .

Is this group cyclic and what is its order?

4. A transformation is called *periodic* with the period  $n$  if the identical transformation is obtained after applying the transformation  $n$  (but not less than  $n$ ) times.

5. If a linear transformation is of the form

$$\frac{w - \zeta_1}{w - \zeta_2} = e^{i\theta} \cdot \frac{z - \zeta_1}{z - \zeta_2},$$

where  $\zeta_1, \zeta_2$  are the *fixed points* of the substitution, it is periodic.

If the fixed points of the linear substitution *coincide*, it is called *parabolic*. If the fixed points are *distinct*, there are three classes of substitution as follows: when the multiplier

$$\frac{a - c\zeta_1}{a - c\zeta_2} = k \text{ (cf. § 14, § 15, § 14)}$$

is a real positive quantity, the substitution is called *hyperbolic*. When this multiplier has its modulus equal to unity and its amplitude different from zero, it is called *elliptic*. If the multiplier has its modulus different from unity and its amplitude not zero, it is called *loxodromic*. For the substitutions with real coefficients only the first three classes occur. These substitutions are often called *real*.

The quadratic equation (12), § 14, which determines the common points of a real substitution has real coefficients; according as the roots of this quadratic are *real*, *equal*, or *imaginary* the real substitution is found to be *hyperbolic*, *parabolic*, or *elliptic*. (These names are due to KLEIN, *Math. Ann.*, Vol. XIV, p. 122.)

In discussing the different cases we put  $(a - d)^2 + 4bc = M$  from the solution of (12), § 14. Thus

$$k = \frac{a - c\zeta_1}{a - c\zeta_2} = \frac{a + d - \sqrt{M}}{a + d + \sqrt{M}}$$

and take  $ad - bc = 1$  (without loss of generality).

For real *elliptic* substitutions,  $\zeta_1$  and  $\zeta_2$  are conjugate imaginaries; hence  $M = (a - d)^2 + 4bc < 0$  or

$$(a + d)^2 < 4(ad - bc) < 4.$$

Therefore  $k$ , using  $ad - bc = 1$ , becomes

$$k = \frac{1}{2}[(a + d)^2 - 2 - i(a + d)\sqrt{4 - (a + d)^2}].$$

The amplitude of  $k$  is thus  $\cos^{-1}[\frac{1}{2}(a + d)^2 - 1]$  and  $|k| = 1$ ; denoting this angle by  $\alpha$  we now obtain

$$k = e^{i\alpha}.$$

If then  $w_p$  be the variable after  $p$  applications of this substitution, we have,

$$\frac{w_p - \zeta_1}{w_p - \zeta_2} = e^{i\theta p} \cdot \frac{z - \zeta_1}{z - \zeta_2}.$$

When  $\theta$  is commensurable with  $2\pi$  so that

$$\frac{\theta}{2\pi} = \frac{s}{r},$$

we have, taking  $p = r$ ,

$$\frac{w_r - \zeta_1}{w_r - \zeta_2} = \frac{z - \zeta_1}{z - \zeta_2};$$

that is,

$$w_r = z;$$

that is, the substitution is *periodic*.

But if  $\theta$  is not commensurable with  $2\pi$ , then, by a proper choice of  $p$ , the amplitude  $p\theta$  can be made to differ from an integral multiple of  $2\pi$  by a very small quantity and leads to an infinitesimal substitution.

6. It is now evident that for the elliptic substitution a  $z$ -circle through  $\zeta_1$  and  $\zeta_2$  and its center therefore on the  $x$ -axis transforms into a  $w$ -circle through  $\zeta_1$  and  $\zeta_2$  cutting the  $z$ -circle at an angle  $\alpha$ .

7. As an illustration of the periodic character of the elliptic transformation let us take the unit circle  $ACBDA$  having its center at the origin. Draw the diameter  $AB$  along the  $y$ -axis. Then the semi-circle  $ACB$  can be regarded as a plane crescent of angle  $\pi/2$  and the semi-circle  $ABD$  as another of the same

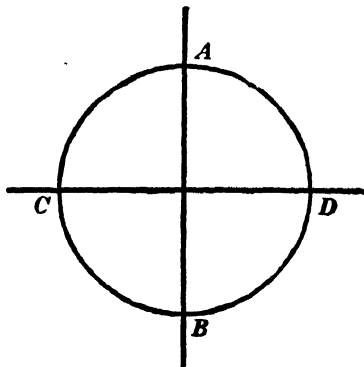

angle. Hence they can be transformed into each other according to a result due to KIRCHHOFF, *Vorlesungen über mathematische Physik*, Vol. I, p. 286.

The transformation can be most simply performed by taking  $A(=i)$  and  $B(=-i)$  as the fixed points of the substitution, which then takes the form

$$\frac{w-i}{w+i} = k \cdot \frac{z-i}{z+i}.$$

The line  $AB$  for the  $w$ -curve is transformed from the  $z$ -circular arc  $ACB$ ; these curves cut at an angle  $\pi/2$ , which is therefore the amplitude of  $k$ . Considerations of symmetry show that the  $z$ -point  $C$  on the  $x$ -axis can be transformed into the  $w$ -origin so that

$$-1 = k \cdot \frac{-1-i}{-1+i},$$

giving  $k=i$  and the substitution

$$\frac{w-i}{w+i} = i \frac{z-i}{z+i}.$$

It is periodic of order 4 as expected: it takes the simple form

$$w = \frac{z+1}{-z+1}.$$

Four applications of the transformation must now give the original region. The first application changes the interior of  $ACBA$  into the interior of  $ABDA$ ; a second application changes this latter region into the region on the positive side of the  $y$ -axis outside of the semi-circle  $ADB$ ; a third application transforms this latter region into the region on the negative side of the  $y$ -axis outside of the semi-circle  $ACB$ ; a fourth transformation completes the period and changes the latter region into the interior of the semi-circle  $ACB$ —the initial region.

8. Show that, if the plane crescent of the preceding example has an angle of  $\frac{\pi}{n}$  instead of  $\frac{\pi}{2}$  and  $+i$  and  $-i$  for its angular points, then the substitution

$$w = \frac{z + \tan \frac{\pi}{2n}}{1 - z \tan \frac{\pi}{2n}},$$

is periodic of order  $2n$ , and if it be applied through a period to the region of the crescent, will divide the plane into  $2n$  regions all but two of which must be crescent in form.

9. For real *parabolic* substitutions the quadratic (12), § 14 has equal roots; the fixed points of the substitution,  $\zeta$  say, thus necessarily coincide on the  $x$ -axis. Thus  $M$  above is zero and  $(d+a)^2 = 4$  and  $d+a = 2$  without loss of generality. Now move both origins to  $\zeta$ , and zero becomes a double root of the quadratic so that  $b = 0$  and  $a - d = 0$ . Hence  $a = d = 1$  and we obtain

$$w = \frac{z}{cz + 1},$$

or,

$$\frac{1}{w} = \frac{1}{z} + c.$$

If the origins are not moved to the point  $\zeta$ , then the substitution is

$$\frac{1}{w - \zeta} = \frac{1}{z - \zeta} + c.$$

Show that the equations of transformation in real coördinates are

$$\frac{x}{u - c(u^2 + v^2)} = \frac{y}{v} = \frac{x^2 + y^2}{u^2 + v^2} = \frac{1}{(1 - cu)^2 + c^2v^2}.$$

10. Show that a  $z$ -circle passing through the origin is transformed by a real parabolic substitution with the origin for its

fixed point into a  $w$ -circle passing through the origin and touching the  $z$ -circle; and a  $z$ -circle touching the  $x$ -axis at the origin is transformed into itself.

11. For real *hyperbolic* substitutions the quadratic has real and unequal roots; the fixed points for the transformation are thus two different points on the  $x$ -axis;  $M$  is thus positive and  $(a+d)^2 > 4$  and we may take  $(a+d) > 2$ . Thus  $k$  is real and positive and the substitution is hyperbolic.

Take the origin as one of the fixed points and  $g$  the distance of the other;  $o$  and  $g$  are then the roots of (12), § 14 with the conditions that  $(ad - bc) = 1$  and  $(a+d) > 2$ . Therefore  $b = 0$ ,  $a - d = cg$ ,  $ad = 1$ ,  $k = a/d$ , and  $k$  is greater or less than 1 according as  $cg$  is positive or negative. Take  $k > 1$  and we obtain

$$w = \frac{az}{cz + d},$$

where  $a > 1 > d$ ,  $(a+d) > 2$ , and  $ad = 1$ .

12. Show, therefore, that a  $z$ -curve, drawn through either of the fixed points of a real hyperbolic substitution, touches the  $w$ -curve into which it is transformed by the substitution.

13. Hence show from Ex. 12 that any  $z$ -circle through the two fixed points of the hyperbolic substitution is transformed into itself.

NOTE. — The above results and many others are due to POINCARÉ, *Acta Math.*, Vol. 1, p. 1 and following.

14. Discuss the transformation

$$w = -\frac{z+1}{z}.$$

### § 19. Rational Integral Functions

We have already defined at the beginning of this chapter (II, § 8) what is in general to be understood by a rational

integral function of a complex variable. If, in the general expression for such a function of a complex variable, we carry out the indicated multiplication of sums or differences according to the distributive law ((2), § 3), and finally collect into one expression all the terms which contain the same power of  $z$  multiplied by a constant, the result may be stated as in analysis of real numbers (A. A. § 20) in the following theorem :

I. *Every rational integral function of  $z$  can be put in the form :*

$$(1) \quad f(z) = a_0 z^n + a_1 z^{n-1} + a_2 z^{n-2} + \cdots + a_{n-1} z + a_n.$$

*The integer  $n$  is called the degree of the function, provided  $a_0 \neq 0$ .*

By using such rational integral functions the following theorem (A. A. § 24) in the field of real numbers may be proved by means of elementary operations :

II. *An equation of the  $n$ th degree has no more than  $n$  roots — unless it is an identity, that is, unless all of the coefficients are each equal to zero. A  $v$ -fold root is counted as  $v$  simple roots in this theorem.*

Since all of the theorems used in the proof of this theorem are valid for complex numbers as well as for real, it follows that *Theorem II is also valid if we extend it to include complex as well as real roots.* But the explicit theorem that every equation of the  $n$ th degree in the field of complex numbers has  $n$  roots is not proved in such a simple manner. We shall obtain it later (VII, § 44, and VIII, § 46) in other ways.

But it is possible to assign limits between which the zeros\* of  $f(z)$  are included. Let  $M$  be a number for which

$$(2) \quad \left| \frac{a_m}{a_0} \right| \leq M \text{ for } m = 1, 2, \dots, n;$$

\* Cf. the paragraph following II, § 20. — S. E. R.

it then follows that

$$\left| \frac{f(z) - a_0 z^n}{a_0} \right| \leq M \{ |z|^{n-1} + |z|^{n-2} + \dots + |z|^2 + |z| + 1 \},$$

that is, 
$$\leq M \frac{|z|^n - 1}{|z| - 1}.$$

For all values of  $z$  whose absolute value is  $\geq M + 1$ , this last fraction is  $\leq |z|^n - 1 < |z|^n$ ; it therefore follows that for all such values of  $z$

$$(3) \quad |f(z) - a_0 z^n| < |a_0 z^n|.$$

In other words it is true that :

III. *The absolute value of the term of highest degree in the rational integral function  $f(z)$  is greater than the absolute value of the sum of all the remaining terms, for all values of  $z$  whose absolute value is greater by at least 1 than the number  $M$  determined by the inequalities (2).*

In particular, it therefore follows that :

IV. *No root of the equation  $f(z) = 0$  can lie outside of the circle described about the origin with the radius  $M + 1$ .*

If, on the other hand,  $a_{n-\nu} z^\nu$  is the term of lowest degree in the rational integral function  $f(z)$  which has one coefficient different from zero, we can put

$$(4) \quad f(z) = z^n \cdot \phi\left(\frac{1}{z}\right),$$

in which

$$(5) \quad \phi\left(\frac{1}{z}\right) = a_{n-\nu} \left(\frac{1}{z}\right)^{n-\nu} + a_{n-\nu-1} \left(\frac{1}{z}\right)^{n-\nu-1} + \dots + a_0$$

is a rational integral function of  $(1/z)$  of degree  $(n - \nu)$ . If we wish to apply Theorem III to this, we must define a number  $m$

by the inequality:

$$\left| \frac{a_k}{a_{n-\nu}} \right| \leq m \text{ for } k = 0, 1, 2, \dots, n - \nu - 1.$$

When  $z$  and  $f$  are again introduced it follows that:

V. *The absolute value of the term of lowest degree in the rational integral function  $f(z)$  is greater than the absolute value of the sum of all the remaining terms, for all values of  $z$  different\* from zero whose absolute value is less than  $(1 + m)^{-1}$ .*

Just as we obtained IV from III, we have here from V:

VI. *No root, except possibly  $z = 0$ , of the equation  $f(z) = 0$  can lie inside of the circle described about the origin with a radius equal to  $(1 + m)^{-1}$ .*

#### EXAMPLES

1. Find the limits of the roots of

$$x^4 - x^3 - 7x^2 + 15x = 0,$$

by making use of Theorems III-VI.

Take  $M = 15$ ; the greatest ratio preceding and up to this one is  $7/15$ . Therefore take  $m = 7/15$ . Hence there is no root outside of the circle of radius  $M + 1 = 16$ , and no root inside the circle of radius  $1/(1 + 7/15) = 15/22$ . This is correct since the roots are  $-3, 2 + i, 2 - i, 0$ .

2. Find the limits of the roots as in Ex. 1 for the equation

$$x^4 - 3x^3 - 14x^2 + 48x - 32 = 0.$$

3. Show that  $4 \cos^2(\pi/7)$  is a root of  $z^3 - 5z^2 + 6z - 1 = 0$  and find the other roots. (*Math. Trip.* 1898.)

\* This limitation is necessary since, in going from  $\phi$  to  $f$  (equation (4)), we multiply by  $z^n$ .

## § 20. Rational Fractional Functions

If all the terms of a rational fractional function (I, § 8) are reduced to a common denominator, we obtain the following theorem:

I. *Every rational fractional function of  $z$  can be represented as the quotient of two rational integral functions:*

$$(1) \quad r(z) = \frac{g(z)}{h(z)} = \frac{a_0 z^n + a_1 z^{n-1} + \dots + a_{n-1} z + a_n}{b_0 z^m + b_1 z^{m-1} + \dots + b_{m-1} z + b_m}.$$

II. *The larger of the two numbers  $m, n$ , or their common value when they are equal to each other, is called the degree of the rational function  $r(z)$ .*

At a point  $z_1$  at which  $g(z)$  and  $h(z)$  are different from zero,  $r(z)$  has a definite finite value different from zero. At a point  $z_1$  at which  $h(z)$  is different from zero but  $g(z) = 0$ ,  $r(z)$  is also zero; and in this case when  $z_1$  is a  $\nu$ -fold zero\* of  $g(z)$  we say also that  $z_1$  is a  $\nu$ -fold zero of  $r(z)$ . At a point at which  $g(z)$  is not zero and  $h(z) = 0$ ,  $r(z) = \infty$  in the sense of § 12. We define further:

III. *A point  $z_1$  which is a  $\nu$ -fold zero of  $h(z)$  and not at the same time a zero of  $g(z)$  is called a  $\nu$ -fold infinity (a  $\nu$ -fold pole)† of  $r(z)$ .*

It is sometimes convenient to use the following form of expression instead of II and III:

IV. *When  $r(z)$  can be put in the form*

$$(2) \quad r(z) = (z - z_1)^\nu \cdot r_1(z),$$

*in which  $r_1$  denotes a function which is finite and different from zero for  $z = z_1$ , then  $\nu$  is called the order of  $r(z)$  at the point  $z_1$ .*

\* Or zero point of the function, that is, such a value of the variable which makes the function vanish. — S. E. R.

† There are other infinities besides poles. Poles are the simplest infinities. Cf. also § 43. — S. E. R.

Accordingly, at a pole the order is negative, at a zero it is positive; if the function at a point is finite and different from zero, then its order at that point is 0.

We have finally to consider an additional case, viz. where  $g(z)$  and  $h(z)$  have a common zero; it may occur after the reductions indicated in Theorem I. *At such a point the value of the rational function itself is completely undetermined (§ 12).* But, by rational operations which do not necessitate a knowledge of the zeros of  $g$  and  $h$  (A. A. § 23), we can find the greatest common divisor  $k(z)$  of  $g(z)$  and  $h(z)$  and thus put  $r(z)$  in the form

$$(3) \quad r(z) = \frac{k(z) \cdot g_1(z)}{k(z) \cdot h_1(z)},$$

in which  $g_1$  and  $h_1$  designate rational integral functions which have no common divisor and therefore (A. A. VI, § 22) have no common zero. If therefore we put

$$(4) \quad \frac{g_1(z)}{h_1(z)} = r_1(z),$$

the equation

$$(5) \quad r(z) = r_1(z)$$

is true for all points except the zeros of  $k(z)$ . Moreover, it is now permissible to add as a definition that:

V. *The function  $r(z)$  takes on the values of  $r_1(z)$  even at the zeros of  $k(z)$  which values may be zero or  $\infty$ .*

With this understanding we state the following theorem:

VI. *The order (IV) of a rational function at any point is equal to the difference of the orders of the numerator and denominator at this point.*

It follows further from II, § 19 that:

VII. *A rational fractional function takes on no value oftener than its degree indicates.*

## EXAMPLES

1. If we divide

$$F(z, w) = (az + bw)(cz + dw) + ew^2 + fw + g$$

by  $G(z, w) = (az + bw), \quad (|a| > 0, |b| > 0),$

both considered as functions of  $z$ , we obtain of course as quotient and remainder

$$Q(z) = (cz + dw), \quad G_1(z) = ew^2 + fw + g.$$

If  $F(z, w)$  and  $G(z, w)$  are both considered as functions of  $w$ , what are the quotient and remainder for this division?

2. Perform the division as in Ex. 1 for the functions

$$F(z, w) = azw + bw^2 + cw + d,$$

$$G(z, w) = zw + e.$$

3. When the real axis is transformed into itself by a linear transformation, it is sufficient that the coefficients of the transformation are all real. Is this condition always *necessary*?

### § 21. Behavior of Rational Functions at Infinity

There are two meanings to be attached to the equation  $z' = f(z)$ . We have usually regarded it as establishing a relation between two *different* points of the same or different planes. But another interpretation was made in (10), § 10, according to which such an equation is used to attach another complex number to the *same* point.

We shall make particular use of this latter idea to investigate *the behavior of any proposed function at infinity*. We put:

$$(1) \quad z' = \frac{1}{z} \text{ and thus } z = \frac{1}{z'},$$

so that the new complex number  $z' = 0$  corresponds to that point of the sphere to which the complex number  $z = \infty$  intro-

duced in § 12 has been heretofore attached. Thus when a definite value is attached to every point of the sphere by the function  $f(z)$ , we can interpret these values as a function of  $z'$  and as such designate them by  $\phi(z')$ . If  $f(z)$  be rational, we need only to replace  $z$  by its value as a function of  $z'$  from (1). We thus obtain a rational function of  $z'$ :

$$(2) \quad f\left(\frac{1}{z'}\right) = \phi(z');$$

this can be represented according to I, § 20 as the quotient of two rational integral functions. The necessary multiplication of numerator and denominator by a power of  $z'$  presupposes of course  $z' \neq 0$ . But since  $f(z)$  for  $z = \infty$  appears in the undetermined form  $\infty/\infty$ , we may write as a *definition* (cf. V, § 20) that:

I. *The value of the rational function  $f(z)$  for  $z = \infty$  shall be understood to be the value of the function  $f(1/z') = \phi(z')$  for  $z' = 0$ .*

This leads to the following result:

If the numerator of a rational function

$$(3) \quad f(z) = \frac{a_0 z^n + \dots + a_n}{b_0 z^m + \dots + b_m}$$

is of higher degree than the denominator, then will

$$(4) \quad \phi(z') = \frac{a_n z'^n + \dots + a_0}{b_m z'^n + \dots + b_0 z'^{n-m}};$$

and  $z' = 0$  is an  $(n - m)$ -fold pole of  $\phi(z')$ ; and therefore, according to the definition I,  $f(\infty) = \infty$  and we say that  $z = \infty$  is an  $(n - m)$ -fold pole of  $f(z)$ .

If  $m = n$ , then

$$(5) \quad \phi(z') = \frac{a_n z'^n + \dots + a_0}{b_n z'^n + \dots + b_0},$$

and  $f(\infty) = \phi(0) = a_0/b_0$  which is finite and different from zero.

If, finally,  $m > n$ , then

$$(6) \quad \phi(z') = \frac{a_n z'^m + \dots + a_0 z'^{m-n}}{b_m z'^m + \dots + b_0},$$

and  $f(\infty) = \phi(0) = 0$ ; and since in this case  $z' = 0$  is an  $(m-n)$ -fold zero of  $\phi(z')$ , we say also that  $z' = \infty$  is an  $(m-n)$ -fold zero of  $f(z)$ .

By extending the definition of order of a function (IV, § 20) to  $z = \infty$ , we find in all three cases that:

II. *The rational function (3) is of order  $m - n$  at  $z = \infty$ ;*

and further (granting the existence of the fundamental theorem of algebra, §§ 44, 46):

III. *The sum of all the orders of any rational function is equal to zero.*

$$\text{§ 21 a. The Function } w = \frac{1}{2}(z + z^{-1})$$

As the first example of a rational fractional function we consider the function:

$$(1) \quad w = \frac{1}{2} \left( z + \frac{1}{z} \right) = \frac{z^2 + 1}{2z}.$$

Since it is of the second degree, it takes on each value at two and only two points of the plane. The relation between any pair of points at which  $w$  takes on the same value can be easily determined here — just as for any function of the second degree: if

$$(2) \quad \frac{1}{2} \left( z' + \frac{1}{z'} \right) = \frac{1}{2} \left( z + \frac{1}{z} \right),$$

it follows readily that either  $z' = z$  or  $z' = z^{-1}$ . *The function  $w$  therefore remains unchanged when subjected to the linear transformation of the variable:*

$$(3) \quad z' = 1/z;$$

*it is an automorphic function.*

This transformation is reducible to a normal form by the methods of § 14. For this purpose it is only necessary to put

$$a = d = 0, \quad b = c = 1.$$

Equation (12), § 14 thus reduces to

$$(4) \quad z^2 - 1 = 0;$$

its roots are  $\pm 1$ , the multiplier  $k$  takes the value  $-1$ , and the transformation (3) can be written in the normal form

$$(5) \quad \frac{z' - 1}{z' + 1} = -\frac{z - 1}{z + 1}.$$

An auxiliary variable  $Z$  may therefore be introduced by the following equations:

$$(6) \quad Z = \frac{z - 1}{z + 1}, \quad z = \frac{1 + Z}{1 - Z}.$$

Therefore

$$(7) \quad w = \frac{1}{2} \left( \frac{1 + Z}{1 - Z} + \frac{1 - Z}{1 + Z} \right) = \frac{1 + Z^2}{1 - Z^2},$$

and conversely:

$$(8) \quad Z^2 = \frac{w - 1}{w + 1}.$$

Moreover if we put

$$(9) \quad W = \frac{w - 1}{w + 1}, \quad w = \frac{1 + W}{1 - W},$$

we obtain:

$$(10) \quad W = Z^2.$$

*Relation (1) between  $w$  and  $z$  can therefore be replaced by the three simpler ones (6), (10), (9), all of which are functions which we have already investigated.*

Since all of these representations are in general conformal, it follows further that:

*The  $z$ -plane is mapped conformally on the  $w$ -plane by the relation (1), particular points excepted.*

We obtain most easily a conception of the conformal representation determined by the function  $w$  by starting with the relation between the  $Z$ -plane and the  $W$ -plane defined by equation (10). The mapping on the  $z$ -plane is then effected by means of equation (6) and on the  $w$ -plane by means of equation (9). We saw in § 17 that the two half-planes of  $Z$  separated by the real axis may be regarded as fundamental regions of the function  $W = Z^2$ . Each of these regions is mapped by this function on the entire  $W$ -plane. If we divide the  $W$ -plane into two half-planes by its real axis, the positive half then corresponds to the first and third quadrants of the  $Z$ -plane and the negative half to the second and fourth quadrants.

Moreover, equation (6) in connection with § 15 shows that real values of  $Z$  correspond to real values of  $z$  and that pure imaginary values of  $Z$  correspond to those values of  $z$  whose absolute value is equal to 1; and from equation (9) it is evident that the  $W$ -axis of reals corresponds to the  $w$ -axis of reals. The corresponding relation of the four planes to each other is therefore shown in the following figures; each plane is divided by the given curves into a number of regions, and those regions which correspond to each other are designated by the same letters. Hence the regions of the  $W$ -plane and of the  $w$ -plane must each contain two letters, since each of these regions corresponds to two different regions of the  $z$ -plane and the  $Z$ -plane.

To carry out the representation more in detail, we map other lines of the  $z$ -plane, according to previous theorems, in turn upon the  $Z$ -plane, the  $W$ -plane, and finally upon the  $w$ -plane. Thus, for example, to the axis of pure imaginaries in the  $z$ -plane corresponds the unit circle of the  $Z$ -plane, to this corresponds the unit circle of the  $W$ -plane, and to this the axis of pure imaginaries of the  $w$ -plane. Accordingly, each of the regions already mentioned are again divided into two subregions which

must correspond separately to each other. In order to determine which regions correspond to each other, we need only to consider that moving along a curve, in the  $z$ -plane, for example, in a certain direction on that curve corresponds to moving along the corresponding curve in the  $w$ -plane in a fixed direction on that curve; and then, since the sense of the angle remains unchanged in this representation, a region which lies to the left when moving along a curve in a certain direction must

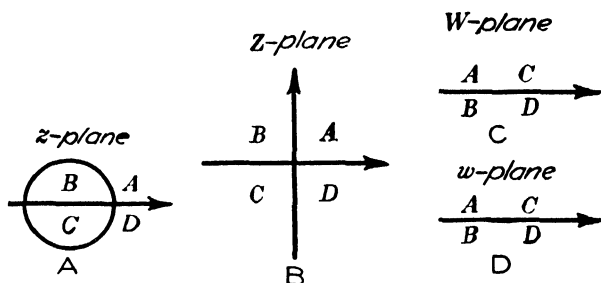

FIG. 13 a-d

respond to a region which lies to the left when moving along the corresponding curve in a definite direction. If, therefore, the correspondence is found for a pair of subregions, no choice remains for the remaining ones, since neighboring regions must have neighboring regions corresponding to them. If the correspondence for all the regions up to the last is determined in this way, we obtain a final check on the problem, since the last one must again border on a preceding one. In this way we obtain the accompanying Figs. 13 e-h.

To go still further into details, let us choose a definite system of curves of one plane such that a curve goes through each point of the plane, and find the corresponding system of curves of the other plane. We might fix in mind, for instance, the straight lines through the origin in the  $z$ -plane and, at the same

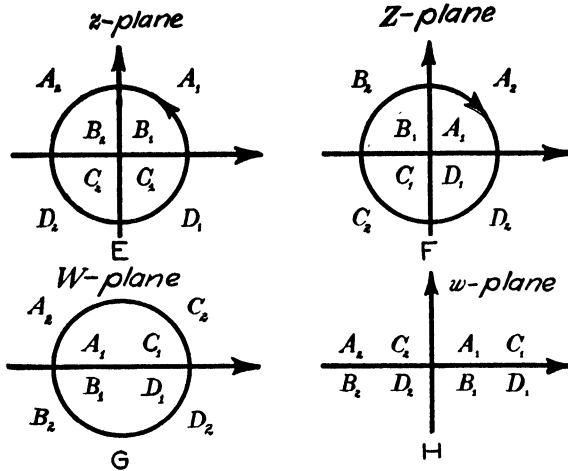

FIG. 13 e-h

time, the circles about the origin perpendicular to them. The relations appear simplest by using polar coördinates in the  $z$ -plane and cartesian coördinates in the  $w$ -plane. Accordingly,

$$(11) \quad z = r(\cos \phi + i \sin \phi), \quad z^{-1} = r^{-1}(\cos \phi - i \sin \phi),$$

and

$$(12) \quad w = u + iv,$$

and therefore

$$(13) \quad u = \frac{1}{2}(r + r^{-1})\cos \phi; \quad v = \frac{1}{2}(r - r^{-1})\sin \phi.$$

If, in these equations,  $\phi$  is regarded as a constant and  $r$  is allowed to take on all values from 0 to  $\infty$ , we obtain the parametric representation of that curve of the  $w$ -plane which corresponds to the rays of amplitude  $\phi$  through the origin of the  $z$ -plane. The equation of this curve is obtained by eliminating the variable parameter  $r$  by squaring and subtracting; we find in this way:

$$\frac{u^2}{\cos^2 \phi} - \frac{v^2}{\sin^2 \phi} = 1.$$

This is the equation of an hyperbola which has the  $u$ -axis as major axis and the  $v$ -axis as minor axis. Its foci are the two points  $+1$  and  $-1$ .

But if we now regard  $r$  in equation (13) as constant and let  $\phi$  take on all values from 0 to  $2\pi$ , we obtain the parametric representation of that curve of the  $w$ -plane which corresponds to the circle of radius  $r$  about the origin of the  $z$ -plane. By eliminating  $\phi$ , we obtain the equation of this curve in the standard form:

$$(15) \quad \frac{4u^2}{(r+r^{-1})^2} + \frac{4v^2}{(r-r^{-1})^2} = 1.$$

This is the equation of an ellipse which has its center, foci, and direction of axes in common with the hyperbola (14). Ellipses and hyperbolas with the same foci are called confocal (cf. VIII, § 17); therefore:

*The circles about the origin and the straight lines through the origin of the  $z$ -plane correspond in the  $w$ -plane to confocal ellipses and hyperbolas with foci at the points  $+1$  and  $-1$ .*

The length of the real semi-axis of the hyperbola (14) is equal to

$$(16) \quad |\cos \phi|.$$

As  $\phi$  increases from 0 to  $\pi$ ,  $|\cos \phi|$  first decreases from 1 to 0 and then increases from 0 to 1. Each of the hyperbolas above thus corresponds in the  $z$ -plane to two different straight lines symmetrical about the  $y$ -axis.

The length of the semi-major axis of the ellipse (15) is equal to

$$(17) \quad \frac{1}{2}(r+r^{-1});$$

each of these ellipses corresponds, therefore, to two different circles of the  $z$ -plane whose radii are reciprocals of each other.

For  $r = 1$ ,  $v = 0$ . But it is not to be inferred from this that the unit circle of the  $z$ -plane corresponds to the entire real axis of the  $w$ -plane; for, it follows from the first of equations (13) that for  $r = 1$  there can be only such values of  $u$  whose absolute value is not greater than 1. The portion of the axis between the common foci of these ellipses and hyperbolas corresponds, therefore, to the unit circle of the  $z$ -plane; it can be regarded as a degenerate ellipse.

But  $v = 0$  when  $\phi = 0$ ; the corresponding values of  $u$  are positive and at least equal to 1, as is shown by an examination of the real function  $u = \frac{1}{2}(r + r^{-1})$  of the real positive variable  $r$ . The positive half of the real axis of the  $z$ -plane corresponds, then, to that part of the positive half of the real axis of the  $w$ -plane from the point  $w = 1$  to  $\infty$ . Likewise, the negative half of the real  $z$ -axis ( $\phi = \pi$ ) corresponds to that part of the negative real  $w$ -axis which extends from the point  $w = -1$  to  $\infty$ . These two parts of the real  $w$ -axis can together be regarded as a degenerate hyperbola.

For  $\phi = \pm \pi/2$ ,  $u = 0$ ;  $v$  takes on all real values from  $-\infty$  to  $+\infty$  ( $+\infty$  to  $-\infty$  resp.) when  $r$  takes on the real positive values from 0 to  $+\infty$ : the  $w$ -axis of imaginaries corresponds to the two  $z$ -half-axes of positive and negative imaginaries; it can also be regarded as a degenerate hyperbola.

Since the mapping is conformal, it follows that these ellipses and hyperbolas always intersect in the same angle as the corresponding circles and straight lines of the  $z$ -plane; that is, in a right angle. We have therefore proved the geometrical theorem that an ellipse and an hyperbola with common foci intersect at right angles.

However, the mapping is not conformal at the points  $z = \pm 1$  to which the points  $w = \pm 1$  resp. correspond. An angle  $2\pi$  of the  $w$ -plane corresponds at these points to an angle  $\pi$  of the  $z$ -plane.

§ 22. A Somewhat More Complicated Example of an Automorphic Rational Function

We have already defined an automorphic function in IV, § 17. If the function is to be *rational* also, then the group of transformations under which the function remains unchanged (VI, § 18) can have only a finite number of transformations (VII, § 20).

Definition :

I. A group which is composed of only a finite number of transformations is called a *finite discontinuous* \* group.

Let  $z' = \lambda(z)$  be a transformation of such a group; then the transformations :

$$(1) \quad \lambda^2(z) \equiv \lambda[\lambda(z)], \quad \lambda^3(z) \equiv \lambda[\lambda^2(z)], \quad \dots$$

compounded from it also belong to the group, according to V, § 18. If it is to be finite and discontinuous, then the transformations (1) cannot all be different from each other; by putting, therefore,

$$\lambda^{n+k}(z) \equiv \lambda^k(z),$$

or, what is the same thing,

$$\lambda^n[\lambda^k(z)] \equiv \lambda^k(z),$$

we introduce a new variable  $Z$  by the equation

$$\lambda^k(z) \equiv Z.$$

If  $\lambda(z)$  is a linear transformation, then  $\lambda^k(z)$  is also a linear transformation according to VI, § 14; hence for any value of  $Z$  there is a corresponding value of  $z$ , and it follows that the resulting equation

$$\lambda^n(Z) \equiv Z$$

\* The term "discontinuous" is necessary here, since we speak of "finite continuous" groups in which the word "finite" does not refer to the number of transformations.

is true for all values of  $Z$ ; in other words, it follows that:

II. *Every transformation of a finite discontinuous group of linear transformations has the property that it gives the original transformation after a finite number of repetitions.*

If, for example (cf. (8), § 15),

$$\lambda(z) = (1 - z),$$

it follows that  $\lambda^2(z) = 1 - \lambda(z) = 1 - (1 - z) = z$ ,

and therefore  $n = 2$  in this case. But if (cf. (9), § 15)

$$\lambda(z) = \frac{z - 1}{z},$$

it follows that

$$\lambda^2(z) = \frac{\lambda(z) - 1}{\lambda(z)} = \frac{(z - 1) - z}{z - 1} = \frac{1}{1 - z},$$

and  $\lambda^3(z) = \frac{\lambda^2(z) - 1}{\lambda^2(z)} = \frac{1 - (1 - z)}{1} = z$ ,

and therefore  $n = 3$ .

Writing the resulting equation in one of the forms

$$\lambda^{n-1}[\lambda(z)] = z \quad \text{or} \quad \lambda[\lambda^{n-1}(z)] = z,$$

shows further that:

IIa. *For each transformation  $z' = \lambda(z)$  of a finite discontinuous group of linear transformations there is another  $z'' = \mu(z)$  having the property that*

$$(2) \quad \mu[\lambda(z)] = z \quad \text{and} \quad \lambda[\mu(z)] = z,$$

or, in other words, such that  $z = \mu(z')$  is the solution of  $z' = \lambda(z)$  for  $z$ . We call  $\mu$  the transformation inverse to  $\lambda$  and designate it by  $\lambda^{-1}$ .

Suppose now that

$$(3) \quad \lambda_0(z) = z, \quad \lambda_1(z), \quad \lambda_2(z), \quad \dots \quad \lambda_{n-1}(z)$$

are the  $N$  different linear transformations of a finite discontinuous group. If  $\lambda_k(z)$  be any one of them, then the  $N$  values

$$(4) \quad \lambda_0[\lambda_k(z)], \lambda_1[\lambda_k(z)], \dots, \lambda_{N-1}[\lambda_k(z)]$$

are all, on account of the character of the group, contained among the  $N$  values (3). But otherwise they are all different from each other. For if, for example,  $\lambda_1[\lambda_k(z)] = \lambda_2[\lambda_k(z)]$ , this relation must remain true if we substitute the value  $\mu_k(z)$  in place of  $z$  in it, understanding  $\mu_k$  to be the transformation inverse to  $\lambda_k$ . From the equation

$$\lambda_1\{\lambda_k[\mu_k(z)]\} = \lambda_2\{\lambda_k[\mu_k(z)]\}$$

thus formed, it would then follow that

$$\lambda_1(z) = \lambda_2(z),$$

since  $\lambda_k[\mu_k(z)] = z$  according to the definition of the transformation inverse to a given one. But that would be a contradiction of the hypothesis that the  $N$  transformations (3) are all different from each other. The  $N$  values (4) are therefore all different from each other; and since they are all contained among the  $N$  values (3), as already shown, we can distinguish them from these  $N$  values only by their arrangement. Let us now form any rational symmetric function of the  $N$  values (3), for example, the sum  $\sum_i \lambda_i(z)$  or the product  $\prod_i \lambda_i(z)$ , and apply to it a transformation of the group (3); that is, replace  $z$  in it by  $\lambda_k(z)$ . It is transformed in this way into the corresponding function of the  $N$  values (4). But since these  $N$  values, as proved above, are different from the  $N$  values (3) only in their arrangement, and since the function is symmetric, it follows that it is entirely unchanged by this transformation; and since this is equally true for every transformation of the group, it follows that it is an automorphic function belonging to the group. We have therefore proved the theorem:

III. *Every symmetric function of the  $N$  values (3) is an automorphic function belonging to the group (3), except when it reduces to a constant. This exception might arise for some known symmetric functions, but not in general (since the values (3) must then be constant). Thus actual automorphic rational functions belong to every finite discontinuous group of linear transformations.*

Such particularly simple functions are obtained as follows: Let  $z_0$  be a fixed point of one or more ( $k$  say) of the transformations (3); that is, let

$$(5) \quad z_0 = \lambda_0(z_0) = \lambda_1(z_0) = \lambda_2(z_0) \cdots = \lambda_{k-1}(z_0);$$

it then follows that

$$(6) \quad \lambda_r(z_0) = \lambda_r[\lambda_1(z_0)] = \cdots = \lambda_r[\lambda_{k-1}(z_0)].$$

Since  $\lambda_r, \lambda_r\lambda_1, \dots, \lambda_r\lambda_{k-1}$  themselves belong to the transformations of the group, these equations tell us that the points into which  $z_0$  is transformed by the transformations of the group are coincident for *each*  $k$  (from which it also follows that  $k$  must be a divisor of  $N$ ). If now  $\phi(z)$  is a linear function of  $z$  for which  $z_0$  is a zero, then  $\lambda_r^{-1}(z_0)$  is a zero of  $\phi[\lambda_r(z_0)]$ ; and since by (II) the set of all the transformations inverse to the transformations of the group is identical with this group itself, it follows that the zeros of

$$\prod_{r=0}^{N-1} \phi[\lambda_r(z)]$$

are coincident for each  $k$ , and that the numerator of this function is the  $k$ th power of an integral function of degree  $(N/k)$ .\* If  $\phi(z)$  is further determined so that also its pole coincides with a fixed point (different from  $z_0$  and its transformed points) of

\* We set aside the case where one of the points  $\lambda_r(z_0)$  lies at infinity; in that case the degree would be depressed. Cf. the example following.

one of the substitutions (1), then the denominator of the product is a power of an integral function.

Let us now apply this to the special case of the group of six transformations which transforms one value of the double ratio of four points into the other five. The substitution  $z' = 1/z$  has  $z_0 = -1$  for a fixed point; the substitution  $z' = z - 1$  has one at infinity. A linear function for which the first is a zero and the latter a pole is  $z + 1$ . It is transformed by the substitutions of the group into

$$(7) \quad \frac{z+1}{z}; \quad z-z; \quad \frac{2z-1}{z}; \quad \frac{2z-1}{z-1}; \quad \frac{2-z}{1-z}.$$

The product of the six values, viz.

$$(8) \quad -\left(\frac{2z^3 - 3z^2 - 3z + 2}{z(z-1)}\right)^2$$

is therefore a function of the double ratio of four  $z$  points which remains unchanged for any permutation of the four points.

To construct a *fundamental region* for this function, we start from the fact that it is a *symmetric* automorphic function. We determine, as in XI, § 18, those curves along which  $F(z)$  is real. The  $z$ -axis of reals is of course one of these; but besides there are those curves along which two and therefore every pair of the six factors are complex conjugates. Now  $z + 1$  is conjugate to  $z - z$  along the line  $x = 1/2$ ; to  $(z + 1)/z$  along the unit circle; to  $(2z - 1)/(z - 1)$  along the circle with its center at 1 and radius 1; on the contrary, it is conjugate to each of the two remaining factors at only certain points. But these three curves and the real axis divide the  $z$ -plane into twelve regions; it is sufficient to use any adjacent pair of these regions on which to map the  $w$ -plane, and since the function  $w$  can take

no value more than six times, further division lines are unnecessary; and thus, as shown in Fig. 14, we have the complete

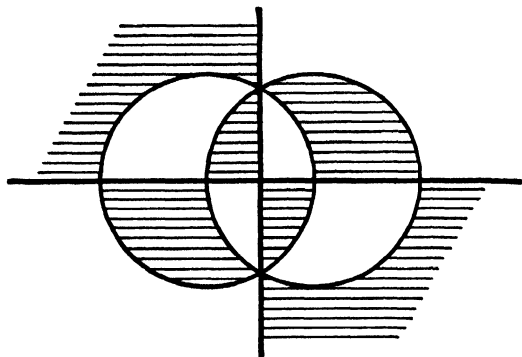

FIG. 14

division of the  $z$ -plane into fundamental regions for the automorphic function  $w$ . It takes on each complex value once and only once in each such region, as will be shown in later theorems (§ 38; § 46).

This figure appears particularly obvious if we transform it stereographically upon the sphere so that the points of intersection of the two circles fall on two points of the sphere diametrically opposite to each other. If we take these points as poles of a system of spherical coordinates, the two circles and their common chord transform into three meridians of the sphere, and since the angle of intersection is unchanged in this transformation (cf. § 34), these three meridians intersect in equal angles. Moreover, the transform of the axis of real numbers must cut these three meridians at right angles; we can so determine the constants at our disposal in the function determining this transformation that this transform becomes the equator of the sphere. The twelve subregions thus become alternately congruent and symmetrical.

To perform analytically the process indicated above, we find the substitution  $z = \phi(\zeta)$  which determines this transformation on the sphere, then replace  $\lambda$  by  $\phi(\zeta)$  and the new variable  $\lambda'$  by  $\phi(\zeta')$  in the equations (7)-(11) of § 15, and finally solve the

resulting equations for  $\zeta'$ . Very simple formulas thus determine the group; the invariant function (8) also takes on a simple form.

The scope of this book does not permit of a more detailed investigation of finite discontinuous groups of linear substitutions.\*

**§ 22 a. An Example of a Rational Integral Function which is not Linear Automorphic**

As an example of a simple rational integral function which is not transformed into itself by any linear transformation, we shall treat the following:

$$(1) \quad w = (z^3 - 3z) = z(z - \sqrt{3})(z + \sqrt{3}).$$

By dividing the function and the independent variable into real and imaginary parts:

$$z = x + iy, \quad w = u + iv,$$

we obtain:

$$(2) \quad \begin{aligned} u &= x^3 - 3xy^2 - 3x = x(x^2 - 3y^2 - 3), \\ v &= 3x^2y - y^3 - 3y = y(3x^2 - y^2 - 3). \end{aligned}$$

Let us now give to  $z$  the values on the axis of real numbers; that is, put  $y = 0$  and let  $x$  take on all values from  $-\infty$  to  $+\infty$ . For such values  $w$  is also real, since  $y = 0$  gives  $v = 0$ . The variable  $w$ , however, takes on some of the values on the real  $w$ -axis more than once, since for  $y = 0$ , the following equation:

$$(3) \quad \frac{\partial u}{\partial x} = 3x^2 - 3 = 3(x - 1)(x + 1)$$

shows that  $w$  is an increasing function for  $z$  increasing only

\* For a detailed account of this theory, see F. KLEIN, *Vorl. über das Ikosaeder*, Lpz., 1884.

while  $-1 > z > 1$ . For  $z = -1$ ,  $w = +2$ , and for  $z = +1$ ,  $w = -2$ ; therefore:

*If  $z$  increases for real values from  $-\infty$  through  $-2$  to  $-1$ , then the real values of  $w$  run, continuously increasing, from  $-\infty$  through  $-2$  to  $+2$ . And if  $z$  increases again from  $-1$  to  $+1$ ,  $w$  remains real, but decreases to  $-2$ . Finally, if  $z$  increases from  $+1$  through  $+2$  to  $+\infty$ ,  $w$  increases from  $-2$  through  $+2$  to  $+\infty$ .*

Therefore, only one real value of  $z$  belongs to each real value of  $w$  whose absolute value is greater than  $+2$ ; on the contrary, for each real value of  $w$  between  $-2$  and  $+2$ , there are three different real values of  $z$  which belong respectively to the three intervals  $(-2, -1)$ ,  $(-1, +1)$ ,  $(+1, +2)$ .

But there are real values of  $w$  for other values of  $z$ . For, according to the second of equations (2),  $v$  is equal to 0 if

$$(4) \quad 3x^2 - y^2 - 3 = 0;$$

and this means geometrically that  $z$  lies on the curve represented by this equation. This curve is an hyperbola whose vertices are the points  $x = -1$  and  $x = +1$ , and whose asymptotes cut the  $x$ -axis at angles of  $\pm 60^\circ$ . To study the points of this hyperbola,  $u$  may be expressed in terms of  $x$  alone; to find this expression we merely take the value of  $y$  from equation (4) and introduce it in the first of equations (2), avoiding in this way the extraction of roots. We obtain:

$$(5) \quad u = x(x^2 - 9x^2 + 9 - 3) = -2x(4x^2 - 3).$$

Two points of the hyperbola with the same abscissa furnish the same real  $w$ . The equation also shows that when  $z$  takes on the values on the left branch of the hyperbola from infinity to its intersection with the  $x$ -axis,  $w$  or  $u$  decreases from  $+\infty$  to  $+2$ ; but if  $z$  takes on the values on the right branch of the

hyperbola from infinity to the vertex,  $w$  increases from  $-\infty$  to  $-2$ . Thus for any real value of  $w$  for which equation (1) has only one real root, there are also two conjugate complex roots. But this exhausts all the values of  $z$  which furnish real values of  $w$ . Hence equation (1) has either three real or one real and two complex roots for real values of  $w$  excepting  $-2$  or  $+2$ .

The  $z$ -plane is divided into six regions, shown in Fig. 14 a, by the three curves whose points furnish real values of  $w$ . All the

points  $z$  belonging to one of these regions have corresponding values of  $w$  for which the imaginary part  $iv$  has the same sign; or briefly: the positive or the negative  $w$ -half-plane corresponds to each of these regions.\* For,  $v$  as a continuous function of  $x$  and  $y$  cannot pass from positive to negative values without going through zero. But, as we have seen, it is zero only when  $z$  crosses one of the curves which bound adjacent regions. To

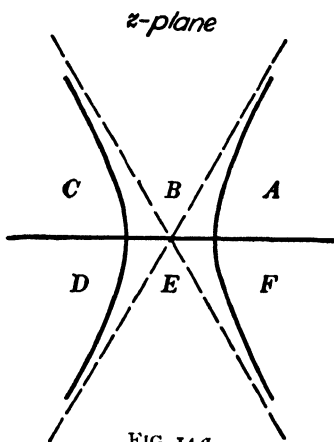

FIG. 14 a

determine whether a certain region corresponds to the positive or to the negative  $w$ -half-plane, we consider merely the corresponding directions in which we move along the curves that bound this region and the corresponding half-plane. For example, if we move along the boundary of the region designated by  $C$  from  $z = -\infty$  along the  $z$  real axis to  $z = -1$  and then return to infinity along the hyperbola, the region  $C$  thus re-

\* From the preceding it has been proved only that one of the given regions of the  $z$ -plane corresponds to a region lying entirely in the positive or entirely in the negative  $w$ -half-plane. That this region covers the corresponding  $w$ -half-plane completely will be first taken up in a later theorem (VIII, § 38).

mains on our *left*; the region corresponding to it in the  $w$ -plane must then also remain on our left when we move along the corresponding curve. But this corresponding curve runs from  $-\infty$  to  $+2$  and then from there to  $+\infty$ . On the left of this path lies that  $w$ -half-plane for which the imaginary part of  $w$  is

$w$ -plane

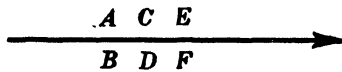

FIG. 14 b

positive. This therefore corresponds to the region  $C$  and is accordingly designated by  $C$  in Fig. 14 b.

We can treat in the same way each of the six regions into which the  $z$ -plane is divided; but this is not necessary, since  $v$  changes sign in crossing either the real  $z$ -axis or the hyperbola; and thus any two regions adjacent to each other in the  $z$ -plane correspond to the two different  $w$ -half-planes. Therefore, whenever the region corresponding to  $C$  is found, the  $w$ -half-planes corresponding to the remaining regions can be determined successively; we obtain a check on the result when at the conclusion we shall have returned to  $C$ .

Further details are obtained by dividing each of the  $w$ -half-planes into two quadrants by the  $w$ -axis of pure imaginaries. We inquire as to what curves of the  $z$ -plane correspond to this line of division; that is, for those values of  $z$  for which  $w$  is pure imaginary, in other words, for which  $u = 0$ . The first of equations (2) shows that this is true for  $x = 0$ , that is, for pure imaginaries in the  $z$ -plane, and also for

$$(6) \quad x^2 - 3y^2 - 3 = 0,$$

that is, for the points of a second hyperbola whose vertices are the points  $x = \pm\sqrt{3}$  and whose asymptotes are inclined at angles of  $\pm 30^\circ$  to the  $x$ -axis. These curves divide each of the six first-mentioned regions of the  $z$ -plane into two subregions, each of

which corresponds to a quadrant of the  $w$ -plane. To determine the quadrant to which each subregion belongs we consider merely the bounding curve and use results already obtained. For example, if the region designated by  $A_1$  borders upon a part of the positive real axis of the  $z$ -plane to which the positive real axis of the  $w$ -plane corresponds, then the region  $A_1$  can only correspond to the first quadrant of the  $w$ -plane. When

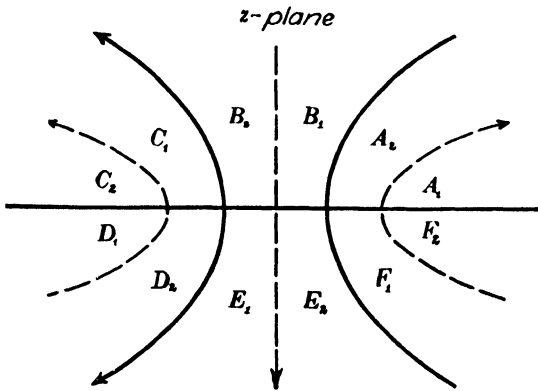

FIG. 14 c

this one is determined we can find, as before, the quadrant to which each of the remaining regions of the  $z$ -plane belongs; we have here, too, several checks on the process, inasmuch as regions with which we end border on some already considered.

To find the curves of the  $w$ -plane which correspond to other curves of the  $z$ -plane, it is found best to express  $x$  and  $y$  in the equation of the curve as functions of a parameter (eventually one of the coördinates itself might be taken as a parameter). If this expression is then introduced in equations (2), we obtain a parametric representation of the corresponding curve in the  $w$ -plane.

Conversely, to find the curve of the  $z$ -plane corresponding to

a given curve of the  $w$ -plane, we merely substitute the expressions (2) for  $u$  and  $v$  in the equation of the first curve given in cartesian coördinates; the equation of the desired curve in  $x$

and  $y$  is thus obtained. But we must also investigate whether *all* points on this curve have corresponding points on the given curve in the  $w$ -plane.

But, very little information concerning the map of one plane upon the other is obtained by the study of such curves. For, apart from the above examples discussed in detail, we obtain in the simplest cases curves whose

properties are not known from elementary analytical geometry. On the contrary, the map determined by the function can be used to facilitate the study of the properties of such curves. It gives direct information as to how a curve of one plane behaves with respect to the regions indicated by letters in our figures just as soon as we know the curve of the other plane corresponding to it.

At this point we discontinue the investigation of rational functions of a complex variable and take up the study of the transcendental functions. Just as in the first chapter the elementary operations on real numbers were applied to complex quantities, we now inquire whether there are not also functions of a complex variable which share the fundamental properties of the elementary transcendental functions of a real variable. The following chapter will serve as a preparation for the answer to this question.

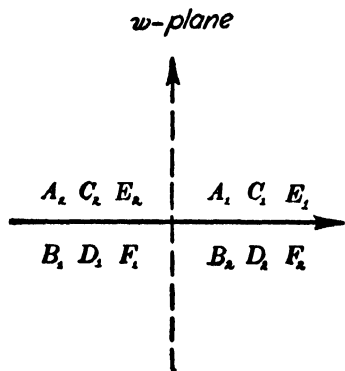
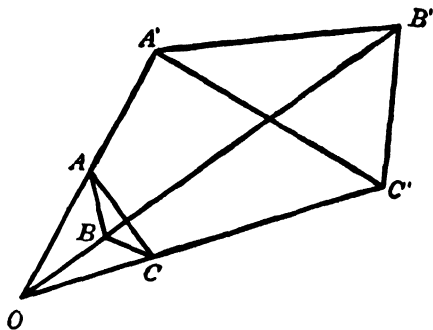

FIG. 14 d

MISCELLANEOUS EXAMPLES

1. Determine the linear fractional transformation which maps the points  $z = z_1, z_2, z_3$ , respectively, into the points  $z' = 0, 1, \infty$ .

2. By means of the accompanying figure in which  $A$  and  $A'$ , etc., are corresponding points, show that angles are inverted in the transformation by reciprocal radii.



3. What are the invariant circles for the transformation  $z' = 1/z$ ? Discuss this example both analytically and geometrically.

[Consider circles with their centers on the  $y$ -axis and through the points  $\pm 1$ ; also circles with their centers on the  $x$ -axis and orthogonal to the unit circle.]

4. Discuss the effect on the systems of straight lines  $x' = \text{const.}$ ,  $y' = \text{const.}$ , by the transformation

$$z' = \frac{1}{z - \zeta}.$$

5. Show that the system of real numbers forms a group with respect to addition.

6. If  $z^2 + w^2 = 1$ , show that  $z, w$  are ends of conjugate radii of an ellipse whose foci are  $\pm 1$ .

7. Show that two fixed points on a circle subtend at any two inverse points angles whose sum is constant.

8. Into what curves is the unit circle  $z \cdot \bar{z} = 1$  (where  $z$  and  $\bar{z}$  are conjugates) transformed by the successive application of the substitution  $z' = (z - 1)/z$ ?

9. Determine the general form of the transformation that transforms  $z \cdot \bar{z} = 1$  into itself (where  $z$  and  $\bar{z}$  are related as in Ex. 8).

10. Describe two kinds of maps of the earth's surface which are conformal.

11. Show that the function  $w = 1/z$  has a simpler geometric interpretation on the sphere than in the plane.

12. The equation

$$\frac{x'^2}{a^2} + \frac{y'^2}{b^2} = 1,$$

which represents an ellipse with semi-axes  $a$ ,  $b$ , is satisfied identically by  $x' = a \cos \phi$ ,  $y' = b \sin \phi$  in which  $\phi$  is the eccentric angle. Show that if  $r$ ,  $r'$  are focal radii of an ellipse having  $x$ ,  $y$  as rectangular coördinates,  $a$  and  $b$  semi-major and semi-minor axes resp., and  $e = \frac{\sqrt{a^2 - b^2}}{a}$  its eccentricity; this ellipse, described in the positive sense, is represented by the equation

$$z = \frac{r + r'}{2} + \frac{r - r'}{2e} \cdot (a \cos \phi + ib \sin \phi), \quad -\pi \leq \phi \leq \pi.$$

If we put

$$\frac{a}{e} = \frac{1}{2} \left( \rho + \frac{1}{\rho} \right), \quad \frac{b}{e} = \frac{1}{2} \left( \rho - \frac{1}{\rho} \right), \quad \cos \phi + i \sin \phi = t,$$

$\rho$  is  $> 1$  and the last equation takes the form

$$z = \frac{r + r'}{2} + \frac{r - r'}{4} \left( \rho t + \frac{1}{\rho t} \right).$$

13. Find the equations for the hyperbola corresponding to those for the ellipse in Ex. 12.

## CHAPTER III

### DEFINITIONS AND THEOREMS ON THE THEORY OF REAL VARIABLES AND THEIR FUNCTIONS

IF the elements of the theory of one real variable and its functions are regarded as known, as in particular the conception of irrational numbers and limits (A. A. chap. VI) and also the idea of continuity (A. A. chap. IX), we can then apply this theory in various ways and show the transition to functions of two real variables.

#### § 23. Sets of Points on a Straight Line; their Upper and Lower Bounds and their Limit Points

It frequently happens that a finite or an infinite number of the real numbers (points)\* of a finite interval † are distinguished by some property not belonging to the others. We then say: *A set of numbers (points) is defined on that interval.* Such a set of points is then, and only then, regarded as defined when it can be determined whether or not any point on the interval belongs to the points of the set; it is not necessary that we should be in possession of methods to determine for each point on the interval whether or not it belongs to the set.‡

\* The numbers being, of course, simply a notation for points. This notation is complete in view of the scheme by which the system of real numbers is set into one-to-one correspondence with the points of a straight line. Cf. VI, § 3 and I, § 4.—S. E. R.

† We call attention here to the usual distinction between *interval* and *segment*. A *segment* ( $a, b$ ), for example, is understood to be the set of all numbers greater than  $a$  and less than  $b$ ; that is, exclusive of the end-points  $a$  and  $b$ ; and an *interval* ( $a, b$ ) is the *segment* ( $a, b$ ) together with  $a$  and  $b$ .—S. E. R.

‡ The terms class, collection, aggregate, assemblage, etc., are synonyms of set.—S. E. R.

I: *The number  $\alpha$  is said to be the upper bound of a set of numbers (points) if the number  $\alpha$  has the property that every number  $\alpha - \epsilon$  but no number  $\alpha + \epsilon$  ( $\epsilon > 0$ ) is exceeded by a number of the set.\* For example,  $\sqrt{2}$  † is the upper bound of all positive numbers whose square is  $< 2$ , and 1 is the upper bound of proper fractions. Similarly, for the lower bound of the set. Then we have the theorem:*

II. *A set of points belonging to an interval always has an upper and a lower bound.*

For, we can divide the rational numbers on the interval into two classes such that every number  $a$  of the one class will be exceeded by at least one number of the set and every number  $A$  of the other class will be exceeded by no number of the set. If there is a smallest one in class  $A$  or a largest one in class  $a$  it is the upper bound, the existence of which has been affirmed. If neither of these is true, then the division ‡  $a | A$  defines an irrational number  $\alpha$  (A. A. § 33), and this is then the upper bound.

If, among the numbers of the set, there is a largest one (as is always the case with a finite set), it is then the upper bound. Otherwise the upper bound does not belong to the set.

For the lower bound, corresponding statements hold.

We shall also make use of the following expression :

III. *A point  $\alpha$  is called a limit point § of a set of points || of the set always lie between  $\alpha - \epsilon$  and  $\alpha + \epsilon$  for every positive  $\epsilon$ .*

\* Of course, as thus defined  $\alpha$  is the *least* upper bound; that is, the least number which is an upper bound. — S. E. R.

† With the understanding that  $\sqrt{2}$  is a number. — S. E. R.

‡ Known as the DEDEKIND Cut or the DEDEKIND Partition. Cf. PIERPONT, *The Theory of Functions of Real Variables*, Vol. I, p. 82. — S. E. R.

§ Synonyms of limit point are accumulation point, cluster point, limiting point, condensation point. — S. E. R.

|| The plural is essential here.

For example, the limiting value of a convergent sequence of numbers is a limit point for the numbers belonging to the sequence. As this example shows, a limit point of a set of points may or may not belong to the set.

A set of points is not necessarily arranged as a convergent sequence of numbers (A. A. § 37); but if it contains a limit point  $\alpha$ , there are then contained in the set sequences which converge to  $\alpha$  and whose numbers all belong to the set.

We now introduce the theorem of WEIERSTRASS:

IV. *An infinite set of points on a finite interval has at least one limit point on this interval.*

The proof of this theorem depends simply upon the definition of an irrational number by a partition in the system of rational numbers. We can divide the rational numbers on the interval into two classes such that every  $a$  of the one class is exceeded by an infinite number of the set, every  $A$  of the other class by only a finite number or by none. The lower end-point certainly belongs to the class  $a$ , the upper end-point without doubt to the class  $A$ , and thus both classes really exist. There is then a number  $\alpha$ , rational or irrational, such that every number smaller than it belongs to  $a$ , every number larger than it belongs to  $A$ . For any positive number  $\epsilon$ , therefore,  $\alpha - \epsilon$  is exceeded by an infinitude of numbers of the set,  $\alpha + \epsilon$  by only a finite number, and hence infinitely many numbers of the set lie between  $\alpha - \epsilon$  and  $\alpha + \epsilon$ ; in other words,  $\alpha$  is a limit point of the set.

Of course, the limit point, the existence of which is proved above, is not necessarily the only limit point of the set; it may have more than one, in fact an infinite number of them; and each point on the interval may be a limit point of the set. This latter, for example, is the case for the set composed of all rational numbers and also for the set made up of all the finite decimal fractions on the interval.

Moreover, as a consequence of the above proof no limit point of the set can be larger than  $\alpha$  designated above. We therefore state the theorem:

V. *Among all the limit points of the set there is always a largest one (and likewise a smallest one); we call that largest one the upper limit (superior limit or  $\bar{L}$ ), the smallest one the lower limit (inferior limit or  $\underline{L}$ ) for the numbers of the set.*

The theorem that a sequence of numbers, which increase continually but not beyond every bound, must be convergent (A. A. § 40) is a special case of the one proved here. The proof of the latter theorem — as also Theorem II — shares with that special case the property that it presents no means to actually specify the numbers whose existence is proved.

If the upper bound of an infinite set does not belong to the set, it is a limit point of the set and is then of course the superior limit  $\bar{L}$ . If however it belongs to the set, it is not necessarily a limit point, and if it is not a limit point, then the superior limit is different from the upper bound.

#### EXAMPLES

1. Recall carefully now the precise definitions of upper (lower) bound, limit point, superior (inferior) limit  $\bar{L}$  ( $\underline{L}$ ). Illustrate each by using the following sets of numbers:

(1) 1, 2, 3.

(2) 1, 1/2, 1/3, ..., 1/n.

(3) 1, 0, 1/2, 1/4, 1/8, ..., 1/2<sup>n-2</sup>.

(4) 2, 4, 6, ..., 2k.

(5) All rational numbers less than unity.

(6) All rational numbers whose square is less than 2.

2. Given the set  $P = \left[ \frac{1}{m} + \frac{1}{n} \right]$ ,  $m$  and  $n$  positive integers.

The limit points of this set form the infinite set 0, 1, 1/2, 1/3, ...,

$1/m$ ; determine which of these limit points belong to the original set. This new set, that is, all the limit points of  $P$ , is called the *derived* set of  $P$  and is denoted by  $P'$ . (The notion of the derived set was introduced by CANTOR, *Math. Annalen*, Vol. V (1872), p. 128.)

3. Consider the set of all positive proper fractions, that is, the set  $P = \left[ \frac{q}{r} \right]$ ,  $q < r$ . What are its limit points? Its upper (lower) bound? Determine the derived set  $P'$ .

4. Write a set of points whose limit points do not belong to the set.

5. Has every infinite set of points a limit point? An upper (lower) bound?

#### § 24. Applications of the preceding Theorems: Continuity on an Interval

A function of a variable is called *continuous* at a point  $x_0$  if to every assigned number  $\epsilon > 0$ , there exists another,  $\delta$ , such that

$$(1) \quad |f(x) - f(x_0)| < \epsilon \text{ whenever } |x - x_0| < \delta,$$

(A. A. § 62); or otherwise expressed (A. A. § 61), if

$$(2) \quad \lim_{x \rightarrow x_0} * f(x) = f(x_0).$$

If this condition is satisfied for all points  $x_0$  on the interval, we consider the question: Is it possible for an assigned  $\epsilon > 0$ , to determine a  $\delta$  so that the inequality

$$(3) \quad |f(x_1) - f(x_0)| < \epsilon$$

\* That is, as  $x$  approaches  $x_0$ , and denoted here by the symbol  $x \rightarrow x_0$ . Cf. also VEULEN and LENNES, *Introduction to Infinitesimal Analysis* (Wiley and Sons, New York), (1907), p. 60.—S. E. R.

is true for *all* pairs of numbers  $x_0, x_1$  of the interval which satisfy the inequality

$$(4) \quad |x_1 - x_0| < \delta?$$

When attention was first called to the concept of uniform approach to a limit of a function (A. A. § 66), it was thought necessary to distinguish between "continuity at each point on the interval" and "uniform continuity on the entire interval." But it soon became evident that a distinction of that kind is not necessary here; rather, the following theorem holds:

I. *When an equation of the special kind (2) is valid for all points on the interval, it necessarily holds uniformly for the entire interval.\**

Assuming that it were not the case, we could then choose any sequence of numbers converging to zero as

$$(5) \quad \delta_1, \delta_2, \delta_3, \dots; \lim \delta_n = 0,$$

and, for each number of the sequence, find two points  $x_{n_0}, x_{n_1}$  on the interval such that

$$(6) \quad |f(x_{n_1}) - f(x_{n_0})| > \epsilon \text{ and } |x_{n_1} - x_{n_0}| < \delta_n.$$

Two possibilities would then arise:

*Either* there would be only a finite number of the points  $x_{n_0}$  which are different from each other. In this case then at least one of these points — call it  $X$  — is such that the inequality (6) is valid for infinitely many values of  $n$ . Since by hypothesis

\* That is, *Every function continuous on an interval is uniformly continuous on that interval.* This is the so-called uniform continuity theorem and is due to E. HEINE, *Crelle*, Vol. 74 (1872), p. 188. Notice also that this theorem does not hold if "segment" is substituted for "interval," as is shown by the function  $1/x$  on the segment  $(0, 1)$ , which is continuous but not uniformly so. The function is defined and continuous for every value of  $x$  on this *segment*, but not for every value of  $x$  on the *interval*  $(0, 1)$ . — S. E. R.

the  $\delta_n$  converge to zero, we can, for the given value of  $\epsilon$  and for each  $\delta$ , so assign another point  $x_{n_1}$  that

$$(7) \quad |f(x_{n_1}) - f(X)| > \epsilon \text{ and } |x_{n_1} - X| < \delta.$$

But this is contrary to the hypothesis that  $f(x)$  is continuous for each value on the interval and hence for  $X$ .

Or there would be infinitely many of the points  $x_{n_0}$  which are different from each other. They must then have at least one limit point according to IV, § 23. Let  $X$  be such a point and then for the given  $\epsilon$  we can find a point  $x_{n_0}$  of this kind and with it another point  $x_{n_1}$  such that

$$(8) \quad |f(x_{n_1}) - f(x_{n_0})| > \epsilon, \quad |x_{n_1} - x_{n_0}| < \delta/2, \quad |x_{n_0} - X| < \delta/2,$$

$$\text{and} \quad |x_{n_1} - X| < \delta.$$

But on that account the two inequalities :

$$(9) \quad |f(x_{n_1}) - f(X)| < \epsilon/2 \text{ and } |f(x_{n_0}) - f(X)| < \epsilon/2$$

cannot be true at the same time, and this means that  $f(x)$  for  $x = X$  is not continuous, contrary to the hypothesis.

Since there is a contradiction in each case Theorem I is proved.

A second application of the theorem on limit points is the proof of the following theorem :

II. *A function  $f(x)$  which is continuous on an interval actually assumes the value of its upper (lower) bound\* at least once on that interval.*

Let  $Y$  be this upper bound. Assuming that  $Y$  itself does not belong to the numbers of the set considered here (that is, to the values taken by the function), then, by the latter part of § 23,

\* As defined in I, § 23.—S. E. R.

it must be a limit point of the set. We can then assign an infinite sequence of values of the function

$$(10) \quad f(x_0), f(x_1), f(x_2), \dots$$

such that

$$(11) \quad \lim_{n \rightarrow \infty} f(x_n) = Y.$$

The corresponding values of the arguments  $x_0, x_1, x_2, \dots$  need not form a convergent sequence. But we can form from them an infinite sequence  $\xi_0, \xi_1, \xi_2, \dots$  which converges to a limit point  $X$  of the set composed of these arguments. Then the functions

$$(12) \quad f(\xi_0), f(\xi_1), f(\xi_2), \dots$$

would also have at least one limit point; but since they are all contained among the numbers (10) and these have only the one limit point  $Y$ , it must follow that

$$(13) \quad \lim_{n \rightarrow \infty} f(\xi_n) = Y.$$

But on account of the assumed continuity of the function  $f(x)$ , it then follows that

$$(14) \quad f(X) = Y. \quad \text{Q.E.D.}$$

Finally, the theorems of the previous paragraphs can be used as follows to free from the assumption of monotony the theorem "A continuous and monotonic function takes on each value lying between its initial and final values" (A. A. II, § 65). If  $f(a) < 0$ ,  $f(b) > 0$ , and if it is to be shown that the function actually takes on the intermediate value 0, we reason as follows: among the values of the argument for which  $f(x)$  is negative, there can be no largest one; for, if  $f(c) < 0$ ,  $\delta$  can be chosen so small that also  $f(c + \delta) < 0$  (cf. A. A. IV, § 64). The upper bound  $\alpha$  of the values  $x$ , for which  $f(x) < 0$ , must then be necessarily a limit point for them, since it does not itself belong to these values; there are then, among the numbers between  $\alpha - \epsilon$

and  $\alpha$  where  $\epsilon$  is arbitrarily small, always numbers for which  $f(x) < \epsilon$ , while for all larger numbers  $f(x) > \epsilon$ . The first, in view of the assumed continuity, makes it impossible (cf. A. A. III, § 39) that  $f(\alpha)$  be  $> \epsilon$ ; the second in view of the continuity makes it impossible that  $f(\alpha)$  be  $< \epsilon$ . Therefore  $f(\alpha)$  must  $= \epsilon$ .

Q.E.D.

We have accordingly the theorem .

III. *A function  $f(x)$  continuous on an interval  $(a, b)$  takes on every value lying between  $f(a)$  and  $f(b)$  at least once for some value of  $x$  lying between  $a$  and  $b$ ,*

even without the limitation of monotony.

We may also mention here a theorem valid under the results of § 20 (cf. A. A. I, § 64):

IV. *A rational function is everywhere continuous where it is finite.*

#### EXAMPLES

1. Consider the function  $y = x^2$  on the segment  $(0, 1)$ . What is the upper (lower) bound, the superior (inferior) limit of  $y$  on this segment? Are these points also limit points for the set of values of  $y$ ?

2. Consider the function  $y = \lim_{n \rightarrow \infty} \frac{x^n}{x^n + 1}$  where  $0 < x < 2$ .

Here  $y = x$  for  $0 \leq x < 1$ ;

$y = 1/2$  for  $x = 1$ ; and  $y = 0$  for  $1 < x \leq 2$ . Answer, for this function, the questions of Ex. 1.

#### § 25. Sets of Points in the Plane

In considering two independent real variables (A. A. § 19) the most convenient geometrical interpretation is to regard them as the rectangular cartesian coördinates of a variable point in the plane. Restrictions on the variation of the two variables are

suitably imposed geometrically; thus, for example, we speak of the point representing the variable as situated on a *surface* or on a *curve*. And too, for example, instead of saying: "We consider only values of  $x$  and  $y$  for which  $(x^2 + y^2) < 1$ ," we say: "We consider only those points within the circle of radius 1 about the origin."

But then it is essential that we define exactly what we mean by the words curve, surface, in order that there may be no uncertainty about the region of validity for the theorems; as we already have the conception of a point as the representative of a number-pair, we must necessarily proceed from that point of view (and not, whatever else might also be possible, from solid to surface and from this to the curve and to the point). We therefore define at present regions\* and curves as sets of points.

The theorems can be stated more briefly by means of the following terminology: †

I. *All of the points whose distance from a given point  $A$  is less than a given number  $\delta$  is called a neighborhood of this point.*

Instead of saying: "We can so determine  $\delta$  that all points in the neighborhood of  $A$  determined by  $\delta$  have a given property," we say more briefly: "All points in the neighborhood (or in a sufficiently small neighborhood) of  $A$  have this property." Thus, for example, the statement: "All points of the neighborhood of the point  $(a, b)$  belong to a given set of points" means the same as: "We can so determine  $\delta$  that all points  $(x, y)$  for which

$$(1) \quad \sqrt{(x-a)^2 + (y-b)^2} < \delta$$

belong to that set of points."

\* In German "Flächenstücke."—S. E. R.

† For bibliography and an exposition in English, the reader is referred to the treatise by W. H. Young and G. C. Young, *The Theory of Sets of Points*, Cambridge, The University Press.—S. E. R.

We define also a "rectangular neighborhood of  $(a, b)$ " by the two inequalities:

$$(2) \quad |x - a| < \delta, \quad |y - b| < \delta.$$

It is evident then geometrically as well as analytically that all points which satisfy inequality (1) also satisfy inequalities (2); and conversely, all points which satisfy (2) also satisfy the inequality.

$$(3) \quad \sqrt{(x - a)^2 + (y - b)^2} < \delta \sqrt{2},$$

which differs from (1) only in having  $\delta \sqrt{2}$  in place of  $\delta$ . Thus, whenever certain properties apply to all the points of a circular neighborhood of  $(a, b)$ , they belong also to all the points of a rectangular neighborhood; and conversely. On that account, this difference is immaterial in many cases; we can use that one of the two ideas which is the more convenient.

By means of this idea of neighborhood, we can now apply the concept, limit point of a set of points, to sets of points in the plane as follows:

II. *A point is called a limit point of a set of points if, in any neighborhood of it (arbitrarily small), there are always other points.\**

III. *A point is called an inner point of a set if a neighborhood of the point belongs entirely to the set.*

IV. *A point is called a boundary point of a set if, in every neighborhood of the point, there are points of the set and also at least one point which does not belong to the set. (It is thus undetermined whether or not the point itself belongs to the set.) Every limit point of the set, which does not belong to it, is a boundary point of the set.*

V. *A point of a set of points, which is not a limit point of the set, is called an isolated point of the set.*

\* The plural is essential here as in III, § 23.

VI. *A set of points which contains no isolated points (that is, a set whose points are all limit points) is called dense in itself.\**

VII. A set of points may have the following property: *Given any two points  $A, B$  of the set and a number  $\epsilon$  (arbitrarily small); if we can always select a finite number of other points OF THE SET so that each of the distances.*

$$AA_1, A_1A_2, \dots, A_{n-1}A_n, A_nB$$

*is smaller than  $\epsilon$ , the set is then said to be connected.*

Examples of such connected sets of points are the lines and surfaces of elementary geometry. But the set is also connected if particular points are excluded from all the points of the set, for example, from all the points inclosed by a circle; and too we obtain connected sets by considering only those points of such a surface whose coördinates are rational numbers, or only those whose coördinates are finite decimal fractions. To pass therefore from the conception of sets of points to that of the curve or the surface, we must exclude such possibilities. For this purpose we define as follows:

VIII. *A set of points which includes all of its boundary points is called closed.*

For "closed and dense," the one word *perfect* is sometimes used.

The two last-named properties — that of being connected and closed — belong to those sets of points which, in elementary geometry, we call curves and also to those which we call surfaces (for example, to the set of points on the circumference of a circle, as also to the set of points inclosed by this, the circumference being part of the last set; without the circumference the interior is not a closed set). The difference is, that

\* In German "in sich dicht." — S. E. R.

the curve contains no inner points in the sense of definition III. From this point of view, we therefore give the following most general definitions of curves and surfaces :

IX. *A connected and closed set of points is called a region if it contains inner points, an arc of a curve if it contains no inner points (composed only of boundary points).*

And too, there are sets of points containing boundary points whose separation from the set leaves it open (that is, not closed) and others having boundary points which may be separated from it and still leave it closed (as, for example, a set consisting of a circular surface with one radius extended). In such cases it is usual, when possible, to so change the definition of a set of points that such points are excluded.

On the other hand, there are points which are naturally inner points but which for special reasons we discuss not as such but as boundary points ; for example, a circular surface " cut open " along a radius. This must be considered separately.

But these previous definitions are much too broad for our purpose : not all sets of points which come under the one or the other of these definitions, have for every curve and surface those properties which we have been accustomed all along to attribute to the curves and surfaces of elementary geometry. We must therefore add further suitable limitations.

For this purpose we start from an entirely different point of view. The curves of elementary geometry can be determined by a so-called *parametric representation* ; that is, if such a curve or an arc of it is given, two continuous functions  $\phi(t)$ ,  $\psi(t)$  of a third variable  $t$  can be chosen in many ways so that all the points of this arc of the curve and only these are obtained when we put

$$(4) \quad x = \phi(t), \quad y = \psi(t),$$

and allow the variable  $t$  to take on the values on a given interval. And too, this representation may always be so arranged that each simple point of the curve is obtained only once.

X. *We can therefore in general regard any set of points defined by two equations with these properties as a curve.*

This definition of a curve is, in one sense narrower, in another, broader than the one given in IX. For, while a set of points defined by equations of this form may have inner points if no further limitations are applied to the functions  $\phi$  and  $\psi$ , yet such a pair of functions is not always sufficient to represent a connected and closed set of points without inner points.

But a formulation at least sufficient for our next purpose is the following :

XI. *In the following, only those sets of points which satisfy at the same time both definitions IX and X are designated as curves.*

XII. *In particular, we designate as a simple curve that one which has no double points, that is, one on which there are always distinct points corresponding to different values of the parameter in equation (4).*

Analogous to this we stipulate further :

XIII. *In what follows we designate as surfaces only those sets of points which satisfy definition IX, and whose boundary points form one or a finite number of simple curves (XI) not intersecting in pairs.*

Further limitations, while not essential, are at all events useful for most of the theorems deduced later. We therefore define further :

XIV. *If the functions  $\phi(t)$ ,  $\psi(t)$  are continuous and partitively monotonic,\* the curve is called a path; and a surface bounded by a path is called a domain.*

\* In German "abteilungsweise monoton." In this connection cf. VEULEN and LENNES, *l.c.*, p. 50. —S. E. R.

In the discussion of later theorems we will be limited mostly to paths and domains. To be sure, we thus exclude a number of cases which are of interest in the theory of functions. In many cases it is possible to discuss such curves and surfaces by regarding them as the limiting cases of paths and domains, resp. But the mere assumption of the limiting process is not usually sufficient; on the contrary, it is necessary in drawing conclusions to pass uniformly to the limit (A. A. § 66). Hence the following definition:

XV. *If the functions  $\phi_n(t)$ ,  $\psi_n(t)$  satisfy the conditions of XIV for every value of  $n$ , and further, if*

$$(5) \quad \lim_{n \rightarrow \infty} \phi_n(t) = \phi(t), \quad \lim_{n \rightarrow \infty} \psi_n(t) = \psi(t)$$

*UNIFORMLY for all values of  $t$  under consideration inclusive of the end-values, then the curve represented by equations (4) is called an improper path, and a surface bounded by a finite number of such curves is called an improper domain.*

XVI. *The theorem on limit points (IV, § 23) is valid also for sets of points in the plane.* For, if we disregard the second coördinate of the points of the set, the results are as in § 23; that is, a number  $\alpha$  can always be found such that infinitely many points of the set have a first coördinate lying between  $\alpha - \epsilon$  and  $\alpha + \epsilon$  for  $\epsilon$  arbitrarily small. Let us now keep in mind only these points, and consider their second coördinate: there is then at least one number  $\beta$  such that infinitely many of the points just determined have a second coördinate lying between  $\beta - \epsilon$  and  $\beta + \epsilon$ . Together these two statements tell us that infinitely many points lie in every neighborhood of the point  $(\alpha, \beta)$ . Q.E.D.

The conclusion in this form assumes that not only the number of points themselves but also the number of different values of their first or their second coördinate is infinite. But this is always

the case excepting only when infinitely many of the points have the same first or the same second coördinate; but in this exceptional case they must lie on a straight line and then the existence of a limit point follows at once from § 23.

XVII. *A domain is called simply connected when any closed curve in it can be contracted to a point by continuous deformation without, in so doing, going outside of the domain.\** For example, the surface of a circle or of a square is simply connected; but not the surface between two concentric circles, since a circle on this surface concentric to the two bounding circles cannot be contracted to a point without going outside of the surface.

#### EXAMPLES

1. Is the surface of a sphere, considered as the stereographic projection of the points of the plane, simply connected? Do two non-intersecting spheres, not bound or joined together in any way, make up a connected surface?

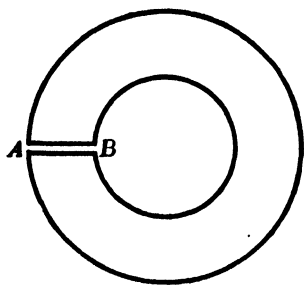

2. Let us consider the area enclosed between and completely bounded by two concentric circles. It is *connected* but not *simply*. We can make it simply connected by setting an impassable barrier. The most effective way to do this is to suppose the surface actually cut along the line of the barrier as *AB* in the adjoining figure. The surface is now a simply connected one.

3. Again, the surface of an anchor ring, not simply connected, can be made so by two barriers. As actual cuts they

\* For a more complete treatment of connectivity see OSGOOD, *Lehrbuch der Funktionentheorie*, Vol. I, p. 144, and FORSYTH, *Theory of Functions*, p. 313.—S. E. R.

would appear as in the accompanying figure.

[This method of resolving surfaces into simply connected ones by the establishment of barriers is that adopted by RIEMANN, *Gesammelte Werke*, pp. 9-12 and 84-89.]

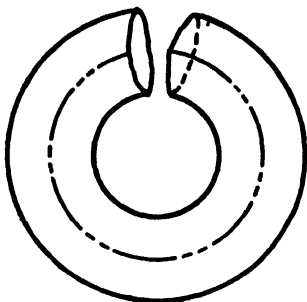

4. Consider the set of points  $P = [0, 1]$ , that is, all the points on the interval  $(0, 1)$ . What are its limit points, upper (lower) bounds? Is it dense; closed? Is the set of Ex. 3 at the end of § 23 dense, closed?

5. Are the following sets dense in itself, closed, perfect?
- (a) A segment not including its end-points.
  - (b) A segment with its end-points.
  - (c) The set of rational numbers.

§ 26. Continuity of Functions of two Real Variables

I. (Definition.) *An equation of the form*

$$(1) \quad \lim_{x \rightarrow a} \lim_{y \rightarrow b} f(x, y) = c$$

*signifies the same as*  $\lim_{x \rightarrow a} \{ \lim_{y \rightarrow b} f(x, y) \} = c,$

in other words, the inner limit is to be evaluated first.

The order of evaluating two successive limits of a function of two real variables is not interchangeable even in simple cases; for example, since

$$(2) \quad \lim_{y \rightarrow 0} \frac{x + y + x^2 + y^2}{x - y - x^2 + y^2} = \frac{1 + x}{1 - x}, \quad \text{the } \lim_{x \rightarrow 0} \lim_{y \rightarrow 0} \frac{x + y + x^2 + y^2}{x - y - x^2 + y^2} = 1;$$

but

$$(3) \quad \lim_{y \rightarrow 0} \lim_{x \rightarrow 0} \frac{x + y + x^2 + y^2}{x - y - x^2 + y^2} = -1.*$$

\* It is interesting to note that  $(x + y)/(x - y)$  would be sufficient here, viz.

$\lim_{y \rightarrow 0} \frac{x + y}{x - y} = \frac{x}{x}$  and  $\lim_{x \rightarrow 0} \frac{x}{x} = 1$ ; but  $\lim_{y \rightarrow 0} \lim_{x \rightarrow 0} \frac{x + y}{x - y} = -1.$  — S. E. R.

II. (Definition.) *The equation*

$$(4) \quad \lim_{\substack{x \rightarrow a \\ y \rightarrow b}} f(x, y) = c$$

means that for every assigned number  $\epsilon > 0$ , there exists another,  $\delta$ , such that

$$(5) \quad |f(x, y) - c| < \epsilon$$

for EVERY pair of numbers  $x, y$  which are different from  $a, b$  and which satisfy the inequality

$$(6) \quad \sqrt{(x-a)^2 + (y-b)^2} < \delta.$$

According to the terminology of § 25, this definition is stated as follows: equation (4) signifies that  $f(x, y)$  is infinitesimally different from  $c$  in the neighborhood of  $(a, b)$  — the point itself excepted.

If equation (4) holds, equation (1) also holds, and too the equation

$$(7) \quad \lim_{t \rightarrow 0} f(a+t, b+\lambda t) = c$$

for every  $\lambda$ . But the converse is not true; for example, while

$$(8) \quad \lim_{x \rightarrow 0} \lim_{y \rightarrow 0} \frac{x^2 - y^2 + x^4}{x^2 + y^2 + y^4} = 1,$$

the following

$$(9) \quad \lim_{t \rightarrow 0} \frac{t^2 - \lambda^2 t^2 + t^4}{t^2 + \lambda^2 t^2 + \lambda^4 t^4} = \frac{1 - \lambda^2}{1 + \lambda^2},$$

which is a function of  $\lambda$ . This would not be the case if we had here an equation like (4).

III. (Definition.) *If the equation*

$$(10) \quad \lim_{\substack{x \rightarrow a \\ y \rightarrow b}} f(x, y) = f(a, b)$$

holds for a function of two variables, then  $f(x, y)$  is a continuous function of  $x$  and  $y$  at the point  $(a, b)$ .

As the example above shows, a function of  $x$  and  $y$  may be a continuous function of  $x$  and also a continuous function of  $y$  for every value of  $x$  and  $y$ , and yet not necessarily be a continuous function of  $x$  and  $y$  in the sense of definition III.

On the contrary, the following theorem holds as for functions of a single variable (§ 24):

IV. *If a function of two variables is a continuous function of these two variables at every point of a finite domain, it is also (uniformly) continuous in the entire domain; that is, for every assigned  $\epsilon > 0$ , there exists another,  $\delta$ , such that,*

$$(11) \quad |f(x_2, y_2) - f(x_1, y_1)| < \epsilon$$

for every pair of points  $(x_1, y_1)$ ,  $(x_2, y_2)$  of the domain which satisfies the inequality

$$(12) \quad \sqrt{(x_2 - x_1)^2 + (y_2 - y_1)^2} < \delta.$$

From this it follows further that:

V. *If  $x, y$  are continuous functions of  $u, v$ , and if  $z$  is a continuous function of  $x, y$ , then  $z$  is a continuous function of  $u, v$ .*

If

$$(13) \quad u = \phi(x, y), \quad v = \psi(x, y)$$

are defined as (single-valued) functions of  $x$  and  $y$  in a domain  $B$  of the  $xy$ -plane, we can interpret  $u, v$  as coördinates of points of another plane. Each point  $(x, y)$  of  $B$  will then have a definite point of the  $uv$ -plane corresponding to it by equation (13); the set of all the points which correspond in this manner to the points of  $B$ , determine a set of points in the  $uv$ -plane. But whether this set of points also determines a region is known only when more details concerning the functions  $\phi, \psi$  are given. It is sufficient here to investigate cases where  $\phi, \psi$  are not merely

continuous functions of the two variables  $x$  and  $y$  but have other limitations given in the course of the investigation.

We proceed indirectly from  $(x, y)$  to  $(u, v)$  by introducing an auxiliary plane  $(\xi, \eta)$  whose points have for coördinates one of the old and one of the new variables; thus:

$$(14) \quad \xi = x, \quad \eta = v = \psi(x, y).$$

We now give to  $x$  a definite value  $a$  (found in  $B$ ); geometrically, this amounts to considering a line parallel to the  $y$ -axis. If this parallel has only one closed and connected segment  $(y_0, y_1)$  (VII, § 25) in common with the domain  $B$ , then  $\eta$  is defined on the corresponding interval as a continuous function of  $y$  by equation (14); for, if  $\psi$  is a continuous function of both variables, it is a continuous function of each separately. Moreover, if  $\psi$  as a function of  $y$  is monotonic on this interval, then to the interval  $(y_0, y_1)$  there corresponds an interval  $(\psi(a, y_0), \psi(a, y_1))$  such that on it, conversely,  $y$  can be regarded as a continuous and monotonic function of  $\eta$ . The interval we are considering on the line parallel to the  $y$ -axis then has a *reversibly unique* correspondence with a definite interval on a line parallel to the  $\eta$ -axis, that is, such that not merely one and only one point  $(\xi, \eta)$  corresponds to each point  $(x, y)$  but, conversely, one and only one point  $(x, y)$  corresponds to each point  $(\xi, \eta)$ .

But if the straight line has two different intervals  $(y_0, y_1)$  and  $(y_2, y_3)$  in common with  $B$ , and if, for example,  $\psi$  is monotonic increasing on each of these intervals, it does not follow from this alone that  $\psi(a, y_2)$  must be  $> \psi(a, y_1)$ . For, each of these intervals has an interval on a line parallel to the  $\eta$ -axis corresponding to it in a reversibly unique manner; but these two latter intervals may overlap so that a part of the interval thus determined is "*doubly covered*." There are therefore *two* points of the  $xy$ -plane corresponding to each point of this last part.

But under the first supposition let us now consider a neighboring straight line  $x = a + h$ . If this too has only one interval in common with  $B$ , there is then an interval on the straight line  $\xi = a + h$  corresponding to it. The end-points  $y_0, y_1$  of this interval take on values for  $x = a + h$  other than those of the corresponding interval for  $x = a$ . But since  $B$  is by supposition a domain,  $y_0(a + h)$  and  $y_1(a + h)$  differ infinitesimally from  $y_0(a)$  and  $y_1(a)$  respectively, for  $h$  sufficiently small; and, on account of the prescribed continuity,  $\psi[(a + h), y_0(a + h)]$  and  $\psi[(a + h), y_1(a + h)]$  differ infinitesimally from  $\psi[a, y_0(a)]$  and  $\psi[a, y_1(a)]$  respectively.

We suppose that these hypotheses hold for *all* values of  $x$  under consideration. Then two *continuous* functions of  $\xi$ , and thus two curves in the  $\xi\eta$ -plane are defined, according to the last proof, by the equations:

$$(15) \quad \eta_0 = \psi[\xi, y_0(\xi)], \quad \eta_1 = \psi[\xi, y_1(\xi)].$$

These curves have no point in common, when we suppose  $\psi$ , as above, to be a monotonic function of its second argument, since for every  $\xi$

$$y_0(\xi) < y_1(\xi).$$

The set of all the points  $(\xi, \eta)$  for which

$$(16) \quad \eta_0(\xi) \leq \eta \leq \eta_1(\xi)$$

forms in the  $\xi\eta$ -plane a region  $C$  which has a reversibly unique correspondence with the domain  $B$ . Moreover, the function

$$(17) \quad y = \theta(\xi, \eta) = \theta(x, v)$$

obtained by reverting the second equation in (14) is, for all  $\xi\eta$  of this region, a continuous function of its two variables and, for  $x$  fixed, is a monotonic function of  $v$ . (The continuity with reference to the two variables is deduced from the corresponding

property of  $\psi$ , as for functions of one variable (A. A. III, § 65)).

If we pass now from the  $\xi\eta$ -plane to the  $uv$ -plane by means of the equations:

$$(I8) \quad u = \phi(x, y) = \phi[\xi, \theta(\xi, \eta)] = f(\xi, \eta), \quad v = \eta$$

we can draw corresponding conclusions if the functions satisfy corresponding hypotheses. In doing so it is only necessary to notice the following conditions: When any parallel to the  $x$ -axis has only one connected interval in common with the domain  $B$ , corresponding conclusions for the  $\xi\eta$ -plane cannot be drawn, since there may be in common with the region  $C$  several distinct intervals on a line parallel to the  $\xi$ -axis. Parts of the  $uv$ -plane could then be multiply covered by the points defined by (I3). This possibility must be excluded, and we have then the following formulation of the results:

VI. *If the functions (I3) are continuous in the domain  $B$  and such that to two different points  $(x, y)$  of this domain there are always two different pairs of values  $(u, v)$ ; if, further,  $\psi$ , for a given  $x$ , is a monotonic function of  $y$  and if the function  $f$  defined by (I8) is, for a given  $\eta$ , a monotonic function of  $\xi$ : then the points of the  $uv$ -plane corresponding to the points of  $B$  by (I3) cover a region  $C$  of this plane uniquely without gaps; and, conversely, in this region  $x, y$  are also continuous functions of  $u, v$ .*

We thus say: *The domain  $B$  is mapped continuously on the region  $C$  by means of the functions (I3).*

### § 27. Derivatives

I. *The derivative of a function  $f(x)$  at a given point  $x$  is defined by the equation:*

$$(I) \quad \frac{dy}{dx} = \lim_{h \rightarrow 0} \frac{f(x+h) - f(x)}{h},$$

*provided, of course, that this limit exists.* If it exists for every value of  $x$ , at least on a given interval, then its values on this interval form a definite function of  $x$ ,  $f'(x)$ , which is called the *derived function* or the *derivative* of  $f(x)$ .

If  $f(x)$  is a rational function of  $x$ , then the function on the right side of equation (1) is a rational function of both the variables  $x$  and  $h$ . Then, according to IV, § 24, for a given value of  $x$ , only two cases can arise, viz.: either the function increases beyond all bounds as  $h$  approaches zero, or the limit exists; but the first case as shown in elementary differential calculus occurs only when the given value of  $x$  makes the denominator of  $f(x)$  zero. Hence the theorem:

II. *A rational function of a real variable always has a definite derivative wherever the function is finite.*

It is not always necessary to apply the definition I directly to the function in order to find its derivative, since, as in the differential calculus, the differentiation of more complicated functions can be made to depend upon the differentiation of simpler ones. Methods for this purpose and the derivatives of the simplest functions are supposed to be known here.

We suppose it known too that a function of a real variable represented by a *power series* has a definite derivative at each inner point on its interval of convergence and that this derivative can be found by differentiation of the given series term by term (A. A. § 81).

Finally, we also suppose it to be known that the derivative, provided it exists at an inner point on the interval, cannot be negative (positive), if the function at that point is increasing (decreasing) for  $x$  increasing, and that it must be equal to zero if the function has at that point a maximum or a minimum.

III. *The partial derivative of a function  $f(x, y)$  with respect to  $x$ , for  $y$  constant, is defined by the equation:*

$$(2) \quad \frac{\partial f}{\partial x} = \lim_{h \neq 0} \frac{f(x+h, y) - f(x, y)}{h}.$$

Two things are necessary for its complete determination, viz.: the determination of the variable with respect to which it is to be differentiated and the variables which are for the process regarded as constant.

Rules for transforming such partial derivatives when passing to new variables are easily established arithmetically, provided we grant the existence and the continuity of the partial derivatives which occur in the process. Under these conditions we suppose such rules to be known.

The hypotheses of Theorem VI, § 26, in which the occurrence of the unknown function  $f$  is somewhat troublesome, can be replaced by simpler but less general ones. For, according to those rules, we have,

$$\left(\frac{\partial u}{\partial \xi}\right)_{\eta=\text{const.}} = \left(\frac{\partial u}{\partial x}\right)_{y=\text{const.}} + \left(\frac{\partial u}{\partial y}\right)_{x=\text{const.}} \cdot \left(\frac{\partial y}{\partial \xi}\right)_{\eta=\text{const.}},$$

$$\text{and} \quad \left(\frac{\partial v}{\partial \xi}\right)_{\eta=\text{const.}} = 0 = \left(\frac{\partial v}{\partial x}\right)_{y=\text{const.}} + \left(\frac{\partial v}{\partial y}\right)_{x=\text{const.}} \cdot \left(\frac{\partial y}{\partial \xi}\right)_{\eta=\text{const.}},$$

and therefore

$$(3) \quad \left(\frac{\partial v}{\partial y}\right)_{x=\text{const.}} \cdot \left(\frac{\partial u}{\partial \xi}\right)_{\eta=\text{const.}} = \frac{\partial u}{\partial x} \cdot \frac{\partial v}{\partial y} - \frac{\partial v}{\partial x} \cdot \frac{\partial u}{\partial y},$$

providing  $y$  is regarded as constant on differentiating with respect to  $x$ , and  $x$  constant on differentiating with respect to  $y$  on the right-hand side of the equations. But since continuous functions can change sign only in passing through zero, it follows that, if the "functional determinant" on the right-hand

side of (3) is different from zero in the entire domain  $B$ , then  $\psi$  for  $x$  constant is a monotonic function of  $y$ , and  $f$  for  $\eta$  constant is a monotonic function of  $\xi$ . From VI, § 26, it therefore follows :

IV. *If  $u, v$  in the domain  $B$  are continuous functions of  $x$  and  $y$  with continuous first partial derivatives and if the functional determinant (3) is different from zero everywhere in  $B$ , then this domain is mapped continuously by  $u, v$  on a region  $C$  of the  $uv$ -plane; in fact, this region of the  $uv$ -plane is thus covered everywhere uniquely, providing that different points of  $B$  always correspond to different pairs of values  $u, v$ .*

Conversely,  $x, y$  inside of  $C$  are therefore continuous functions of  $u, v$  with continuous first partial derivatives which are found by known rules.

### § 28. Integration

We must go somewhat more into detail concerning the arithmetical definition of the definite integral of a function of a real variable. Let  $(a, b)$  be an interval, and let a function  $f(x)$  be given on it. Divide this interval into any number of subintervals by the points  $x_1, x_2, \dots, x_n$ ,\* let  $M_v$  represent the *upper* bound of the values of the function belonging to each of these subintervals, and form the sum :

$$(1) \quad M_0(x_1 - a) + M_1(x_2 - x_1) + M_2(x_3 - x_2) + \dots \\ + M_{n-1}(x_n - x_{n-1}) + M_n(b - x_n).$$

This sum has different values according to the choice of the points determining the partition. But when the values which the function takes on on the given interval all lie between two

\* That is, let  $x_0 = a, x_1, x_2, \dots, x_{n+1} = b$  be a set of points lying in order from  $a$  to  $b$ . Such a set of points is called a *partition* of the interval  $(a, b)$ . The intervals  $(x_k, x_{k+1})$  ( $k = 1, 2, \dots, n$ ) are intervals of  $(a, b)$ . — S. E. R.

finite limits  $m$  and  $M$ , then all possible values of the sum (1) lie on the finite interval  $[m(b-a), M(b-a)]$  and therefore have a lower bound according to II, § 23.

I. *This lower bound of the values of the sum (1) is called the upper integral\* of the function  $f(x)$  between the limits  $a$  and  $b$ .*

Under the same assumptions there is an upper bound to the values of the sum

$$(2) \quad m_0(x_1 - a) + m_1(x_2 - x_1) + m_2(x_3 - x_2) + \dots \\ + m_{n-1}(x_n - x_{n-1}) + m_n(b - x_n),$$

in which  $m_\nu$  designates the lower bound of the values of the function on the interval  $(x_\nu, x_{\nu+1})$ .

II. *This upper bound is called the lower integral of  $f(x)$  between the limits  $a$  and  $b$ .*

No value of (2) is greater than any value of (1) even when intermediate points are used for the formation of (2) other than those used for (1); we see this by further partitioning every subinterval used for (1) by the points used for (2). Thus the lower integral cannot be greater than the upper integral, but at most equal to it.

III. *When the upper integral is equal to the lower, we call their common value simply the integral of  $f(x)$  between  $a$  and  $b$ ; and the function  $f(x)$  is then said to be integrable on the interval  $(a, b)$ .*

But this is always the case if  $f(x)$  is continuous on the interval. For then according to I, § 24, for every assigned number  $\epsilon > 0$  another,  $\delta$ , can be so determined that, for any two points

\*The terms *upper integral* (*oberes integral*) and *lower integral* (*unteres integral*) were introduced by DARBOUX, *Annales de l'école normale*, ser. 2, Vol. IV, and also by THOMAE, *Einleitung*, etc., p. 12. JORDAN, *Cours d'Analyse*, Vol. I, p. 34, called them "l'intégrale par excès" and "l'intégrale par défaut."—S. E. R.

$x_1, x_2$  of the interval,

$$|f(x_2) - f(x_1)| < \frac{\epsilon}{b-a} \text{ whenever } |x_2 - x_1| < \delta.$$

But then

$$(3) \quad |M_\nu - m_\nu| \leq \frac{\epsilon}{b-a},$$

whenever  $|x_{\nu+1} - x_\nu| < \delta$ . If the points of partition are therefore chosen so that these inequalities hold for each subinterval, we obtain two values of the sums (1) and (2) which are different from each other by  $\epsilon$  at most. But that would not be possible if the upper bound of the smaller sum was different from the lower bound of the larger sum by more than  $\epsilon$ . Since this is true for any value of  $\epsilon$ , these two bounds must be equal to each other (A. A. Cor. to II, § 39). We have thus proved the theorem:

IV. *A function is integrable on every interval on which it is continuous.*

It may be mentioned here without proving, that the converse of this theorem does not hold.

The following theorem also arises from the same proof:

V. *If  $f(x)$  is integrable on the interval  $(a, b)$ , then for each assigned degree of approximation  $\epsilon$  we can determine another,  $\delta$ , so that the difference between the value of the sum*

$$(4) \quad (x_1 - a)f(\xi_0) + (x_2 - x_1)f(\xi_1) + \cdots + (b - x_n)f(\xi_n)$$

*and the value of the integral*

$$(5) \quad \int_a^b f(x) dx$$

*is less than  $\epsilon(b-a)$ , however the subintervals  $(x_\nu, x_{\nu+1})$  and on them the intermediate values  $\xi_\nu$  may be chosen, provided only that each of these subintervals is smaller than  $\delta$ .*

There arises thus the possibility of computing the integral of a continuous function to an arbitrary approximation pre-assigned.

The elementary theorems about the integral of a sum, etc., about partitions of the interval of integration, about the introduction of a new variable of integration all follow without fundamental difficulties from the definition of an integral used here.

If  $a$ , one of the two limits of integration of a continuous function, is kept fixed, while the other,  $b$ , is considered as a variable and as such denoted by  $x$ , then the value of the integral appears as a function of this variable; let this function be denoted by  $F(x)$ . If  $m$  and  $M$  are upper and lower bounds of the values of the function  $f$  on the interval  $(x, x+h)$ , then  $F(x+h) - F(x) = \int_x^{x+h} f(\xi) d\xi$  lies between  $mh$  and  $Mh$ ; hence

$$(6) \quad m < \frac{F(x+h) - F(x)}{h} < M,$$

and from this it follows in any case that

$$(7) \quad \lim_{h \neq 0} F(x+h) = F(x)$$

and also, on account of A. A. IV, § 39 when  $f(x)$  is in addition to this continuous, that

$$(8) \quad \lim_{h \neq 0} \frac{F(x+h) - F(x)}{h} = f(x);$$

that is,

VI. *The value of the integral of a continuous function is a continuous and, when the integrand is continuous, also a differentiable function of its upper limit; and, in fact, its derivative is in the latter case equal to the given function itself.*

Differentiation and integration are thus reciprocal operations.

Therefore methods for the integration of rational integral functions or of functions represented by convergent power series are deduced by reversing the corresponding formulas for differentiation; these too are supposed to be known here.

The following theorem now enables us to obtain the integrals of more complicated functions.

VII. *If on the interval  $(a, b)$*

$$(9) \quad \lim_{n \rightarrow \infty} f_n(x) = f(x) \text{ uniformly as to } x,$$

then is

$$(10) \quad \lim_{n \rightarrow \infty} \int_a^b f_n(x) dx = \int_a^b f(x) dx.$$

For, hypothesis (9) about the uniformity of approaching the limit means that, for every  $\epsilon$  we can find an  $N$  such that for every  $x$  on the interval

$$(11) \quad |f(x) - f_n(x)| < \epsilon \text{ where } n > N.$$

But by one of the elementary methods concerning integration just mentioned, the integral of a difference is equal to the difference of the integrals of minuend and subtrahend and the absolute value of an integral is at most equal to the integral of the absolute value of the integrand; it follows therefore from (11) that

$$(12) \quad \left| \int_a^b f(x) dx - \int_a^b f_n(x) dx \right| < \epsilon(b-a) \text{ whenever } n > N.$$

Since  $\epsilon(b-a)$  becomes arbitrarily small as  $\epsilon \doteq 0$ , the proof of equation (10) is complete.

VIII. *In particular, an infinite series which is uniformly convergent can be integrated term by term.*

There are no corresponding theorems for differentiation: from the hypothesis alone that on a given interval the absolute

value of a function remains less than a given number, nothing can be concluded as to the value of its derivative on this interval. But by the application of VII and VIII to the functions  $\frac{df_n(x)}{dx}$  we can at least obtain the two following theorems :

IX. *If in the neighborhood of a given point  $x$*

$$\lim_{n \rightarrow \infty} f_n(x) = f(x),$$

*IF, FURTHER, THE FUNCTIONS  $\frac{df_n(x)}{dx}$  ARE CONTINUOUS AND APPROACH UNIFORMLY TO A DEFINITE FUNCTION IN THE LIMIT AS  $N$  INCREASES, THEN  $f(x)$  HAS A DEFINITE DERIVATIVE AT THAT POINT WHICH IS EQUAL TO THIS DEFINITE FUNCTION.*

X. *A convergent series of functions with continuous derivatives may be differentiated term by term, WHEN THE SERIES SO FORMED IS UNIFORMLY CONVERGENT.*

The extension of Theorems VII–X to the case where the general limiting process is employed (A. A. § 62) presents no new difficulties.

### § 29. Curvilinear Integrals

I. *If in the plane a path  $C$  from a point whose abscissa is  $a$  to a point whose abscissa is  $b$  is given by the monotonic and continuous function*

$$(1) \quad y = f(x),$$

*and if there is also given a function  $P(x, y)$ , continuous at least along this path, then we shall understand the CURVILINEAR INTEGRAL.*

$$(2) \quad \int_{(C)} P(x, y) dx$$

*along the path  $C$  to be the integral*

$$(3) \quad \int_a^b P(x, f(x)) dx.$$

II. *A curvilinear integral changes its sign if we change the sense of the direction in which the path is taken.*

Similarly  $\int Q(x, y)dy$  is defined; \* instead of  $\int Pdx + \int Qdy$  we may write more briefly  $\int (Pdx + Qdy)$ .

The curvilinear integral along any path (XIV, § 25) can therefore be defined as that integral which is equal to the sum of its values along the separate parts into which the path is divided, provided that for each of these parts  $y$  is a monotonic function of  $x$  and  $x$  is a monotonic function of  $y$ .

If the functions  $x = \phi(t)$ ,  $y = \psi(t)$  defining the path are differentiable, then

$$(4) \quad \int (Pdx + Qdy) = \int [P\phi'(t) + Q\psi'(t)] dt.$$

But if this is not the case, the curvilinear integral can be computed to an arbitrary approximation by a summation of the form :

$$(5) \quad \Sigma [P(\xi_\nu, \eta_\nu)(x_{\nu+1} - x_\nu) + Q(\xi_\nu, \eta_\nu)(y_{\nu+1} - y_\nu)].$$

The following theorem, as also Theorems VII, VIII, § 28 are valid for curvilinear integrals :

III. *If the functions  $P, Q$  are continuous in a domain of the plane and if, in this domain, there is given a set of paths  $C_n$  which approach UNIFORMLY to a definite path  $C$  of the domain as  $n$  increases, then is*

$$(6) \quad \lim_{n \rightarrow \infty} \int_{(C_n)} (Pdx + Qdy) = \int_{(C)} (Pdx + Qdy).$$

The proof rests upon the fact that  $P[x, f(x)]dx$  is a continuous function of  $x$  when  $P(x, y)$  is a continuous function of  $x$

\* It is only necessary to assume  $f$  monotonic here in order that  $x$  may be a single-valued function of  $y$ .

and  $y$ , and  $f(x)$  is a continuous function of  $x$ , and upon VII, § 28.

IV. *And, if  $C = \lim C_n$  is not a proper but an improper path, we conclude from the premises that the limit on the left side of (6) exists and that it depends only upon  $C$  and not upon the set of curves  $C_n$  used to approximate to  $C$ . It can therefore be used to DEFINE the curvilinear integral for this case.*

V. *In particular, we can approximate uniformly and arbitrarily to any path of integration by a so-called "RECTANGULAR CONTOUR,"\* that is, by a path composed of straight line segments which are alternately parallel to each of the coördinate axes.*

For, 1: If  $y$  is a continuous and monotonic function of  $x$  along the path and conversely, and if the degree of approximation  $\epsilon$  is preassigned, we can then find a finite number of points  $x_\nu, y_\nu$  on the path such that none of the differences  $|x_{\nu+1} - x_\nu|, |y_{\nu+1} - y_\nu|$  is greater than  $\epsilon/\sqrt{2}$ . Then, on account of the presupposed monotony, the piece ( $\nu \dots \nu + 1$ ) of the path lies entirely within the rectangle whose vertices are the four points  $(x_\nu, y_\nu), (x_{\nu+1}, y_\nu), (x_{\nu+1}, y_{\nu+1}), (x_\nu, y_{\nu+1})$ ; and none of the points of the path are more than the distance  $\epsilon$  from any one point of the sides of the rectangle. Hence the part of the curve connecting  $(x_\nu, y_\nu)$  and  $(x_{\nu+1}, y_{\nu+1})$  can be replaced, with an approximation  $\epsilon$ , by a pair of intersecting sides of this rectangle.

2. If the path is a proper one (XIV, § 25), we can divide it into a finite number of pieces, for each of which the hypotheses of the first case above are fulfilled.

3. If, finally, the path is improper, it can be replaced with an approximation  $\epsilon/2$ , by a proper path which is then replaceable, with an approximation  $\epsilon/2$ , by a "rectangular contour." There-

\* In German "Treppenweg." — S. E. R.

more this improper path is replaceable by a "rectangular contour" with an approximation  $\epsilon$ .

It is also possible to approximate to a given curve by a "rectangular contour" whose vertices have *rational* coördinates.

VI. If  $Pdx + Qdy$  is the total differential  $dF$  of a uniform and continuous function  $F(x, y)$  in the domain under consideration, then

$$(7) \quad \int_{(x_0, y_0)}^{(x_1, y_1)} (Pdx + Qdy) = F(x_1, y_1) - F(x_0, y_0),$$

however the path of integration from  $(x_0, y_0)$  to  $(x_1, y_1)$  is chosen in this domain. This is evident at once if  $\phi(t)$ ,  $\psi(t)$  are differentiable along the path; for then, by introducing  $t$  as variable of integration, the integrand on the left side of (7)

becomes: 
$$\frac{\partial F}{\partial x} \cdot \frac{dx}{dt} \cdot dt + \frac{\partial F}{\partial y} \cdot \frac{dy}{dt} \cdot dt = \frac{dF}{dt} \cdot dt.$$

The same result is obtained for other paths by means of Theorems III and IV.

In the general case, on the contrary, the value of the curvilinear integral, taken along a path connecting two given points of the plane, depends not only upon those two points, but essentially upon the path, since two paths which connect the same two points give, in general, different values of the integral. In particular, the value of the integral taken along a closed path is not necessarily zero. For our purpose it is not necessary to investigate the most general conditions under which this occurs; it is sufficient to deduce the following theorems:

If we connect two points  $BD$  of a closed path of integration  $ABCD$  by a path  $BED$  which does not intersect the first one, we obtain two closed paths of integration  $ABEDA$  and  $BCDEB$ . Then, in general,

$$\int_{ABEDA} = \int_{BED} + \int_{DAB}, \quad \int_{BCDEB} = \int_{BCD} + \int_{DEB}$$

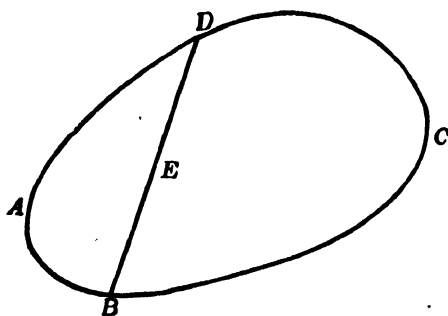

FIG. 15

and

$$\int_{ABCDA} = \int_{DAB} + \int_{BCD}$$

but

$$\int_{DEB} = -\int_{BED};$$

therefore:

$$\int_{ABCDA} = \int_{ABEDA} + \int_{BCDEB}$$

Repetition of this result gives the following theorem:

VII. *If a domain is divided by paths into an arbitrary number of subdomains, then a given integral, taken along the boundary of the entire domain, is equal to the sum of the corresponding integrals taken in the same direction along the boundaries of the separate subdomains.*

From this we conclude at once that if the integral is zero for every closed path of integration sufficiently small within a simply connected domain,\* it is also zero for any closed path of integration which lies entirely within this domain. However, the following theorem is more important:

VIII. *If an integral, taken along the boundary of any square the length of whose side is  $\delta$  and which lies entirely within a domain  $B$ , is smaller than  $\delta^2\epsilon$  for  $\delta$  sufficiently small, then it is zero for every closed path of integration belonging entirely to this domain (where  $\epsilon$  is understood to be a number independent of the selection of this square, and which approaches zero as  $\delta$  approaches zero).*

\* The hypothesis of simple connectivity cannot, as a matter of fact, be dispensed with here; the curves given as examples in XVII, § 25 cannot be replaced by paths of integration arbitrarily small if they traverse the entire ring between two concentric circles.

For, if we have given a domain bounded by a closed "rectangular contour," which may be entirely filled in by such squares, the value of the integral around it is smaller than  $\epsilon \Sigma \delta^2$ . But  $\Sigma \delta^2$  is the surface  $F$  inclosed by the "rectangular contour" and is therefore a definite number. The value of the integral must then be smaller than the product of this number  $F$  and a number  $\epsilon$  which can be taken arbitrarily small. That is only possible when it is zero.

The same theorem is valid for any other arbitrary closed path of integration, as we perceive by approximating to it by a "rectangular contour" whose vertices have rational coördinates.

But in the application of this theorem it is not convenient to suppose  $\epsilon$  independent of the selection of the square.

IX. *But the same result is obtained by supposing that to any point of  $B$  there belongs an  $\epsilon$  such that the conditions of VIII are satisfied for every square belonging to the neighborhood of this point.*

For, suppose the integral around any such a domain were in absolute value  $> A$ ; we then divide the path into two parts; for at least one of these the integral must therefore be  $> \frac{A}{2}$ . We divide this one again; for at least one of the new parts the integral must then be  $> \frac{A}{4}$ . Continuing thus we arrive after  $n$  divisions at a domain of the surface  $F/2^n$  for whose boundary that integral would be  $> A/2^n$ . But we can carry the division so far that one of the subdomains thus obtained, and all the following ones, would belong entirely to the neighborhood of one of its points; for, the set of its vertices must have at least one limit point. For one such subdomain, the integral along the boundary would therefore on the one hand be  $< \epsilon F/2^n$  and on the other hand  $> A/2^n$ . But this leads to a contradiction,

since  $\epsilon$  can be chosen arbitrarily small; the contradiction disappears only for  $A = 0$ .\*

### MISCELLANEOUS EXAMPLES

1. Discuss the sets  $P = \frac{3}{2}, \frac{4}{8}, \frac{5}{4}, \frac{6}{8} \dots$ ; that is,  $\left[ \frac{n+1}{n} \right]$ ,

$$P = \frac{1}{2}, \frac{3}{2}, \frac{1}{8}, \frac{4}{8}, \frac{1}{4}, \frac{5}{4} \dots; \text{ that is, } \left[ \frac{1}{n}, \frac{n+1}{n} \right], n > 1$$

and integral, as to upper (lower) bound, limit points, superior (inferior) limit  $\bar{L}$  ( $\underline{L}$ ), derived sets, and whether dense, closed.

2. The positive rational numbers can be arranged in the form of a simple sequence as follows:

$$\frac{1}{1}, \frac{2}{1}, \frac{1}{2}, \frac{3}{1}, \frac{2}{2}, \frac{1}{3}, \frac{4}{1}, \frac{3}{2}, \frac{2}{3}, \frac{1}{4}, \dots$$

Show that  $p/q$  is the  $\left[ \frac{1}{2}(p+q-1)(p+q-2) + q \right]^{\text{th}}$  term of the series.

Discuss for continuity the functions:

3.  $y = 1/x^2$  at  $x = 0$ .

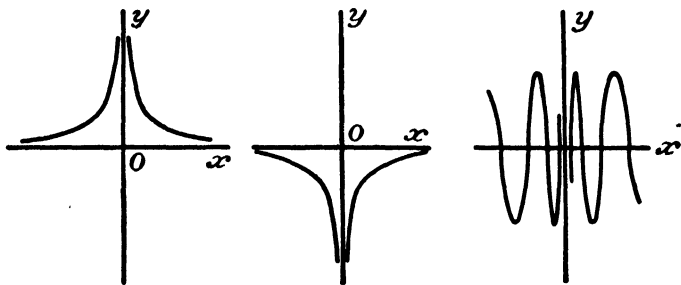

4.  $y = \frac{-1}{|x|}$  at  $x = 0$ .      5.  $y = 1/x$  at  $x = 0$ .

\* For this and many similar arguments the HEINE-BOREL theorem is of direct use. For an exposition of this theorem see VEULEN AND LENNES, *l. c.*, p. 34. —S. E. R.

6.  $y = \sin \frac{1}{x}$  at  $x = 0$ . In this case discuss also the oscillations of  $y$  and find its value as  $x \doteq 0$  from the left; from the right.

7.  $y = x \cdot \sin \frac{1}{x}$  at  $x = 0$ . Discuss as in Ex. 6.

8.  $y = \frac{1}{x^2} + x \cdot \sin \frac{1}{x}$  at  $x = 0$ . Here  $y$  oscillates about the curve  $y = 1/x^2$ . Show that the amplitude of these oscillations converges to zero as  $x \doteq 0$ .

9.  $y = \frac{1}{x} \cdot \sin \frac{1}{x}$  at  $x = 0$ . Here  $y$  oscillates between the two hyperbolas  $y = \pm 1/x$ . Show that as  $x \doteq 0$  the amplitude of these oscillations increases indefinitely.

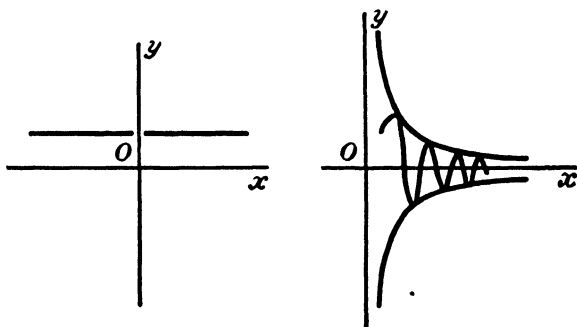

10. Let  $y = 1$  for  $x \neq 0$  and  $y = 0$  for  $x = 0$ . The analytic expression of  $y$  is then

$$y = \lim_{n \rightarrow \infty} \left( \frac{nx}{1 + nx} \right).$$

In what respect is the discontinuity in this case different from that in the other examples just studied?

The two following are examples of *continuous* functions for which progressive or regressive derivatives at certain points do not exist.

11. Let 
$$y = x \cdot \sin \frac{\pi}{x} \text{ for } x \neq 0 \text{ and}$$

$$= 0 \text{ for } x = 0.$$

Here  $y$  oscillates infinitely often between the lines  $y = \pm x$  as  $x \rightarrow 0$ . Now for  $x \neq 0$ ,  $y$  is certainly continuous; but it is also continuous for  $x = 0$  since  $\lim_{x \rightarrow 0} \left( x \cdot \sin \frac{\pi}{x} \right) = 0$ . At the origin there is no tangent at all to the curve since a secant at the origin oscillates between the two lines and approaches no fixed position.

Analytically, this is shown as follows:

$$\frac{\Delta y}{\Delta x} = \sin \frac{\pi}{\Delta x} \text{ at } x = 0.$$

As  $\Delta x \rightarrow 0$ ,  $\sin \frac{\pi}{\Delta x}$  oscillates infinitely often between  $\pm 1$ . Cf. Ex. 6.

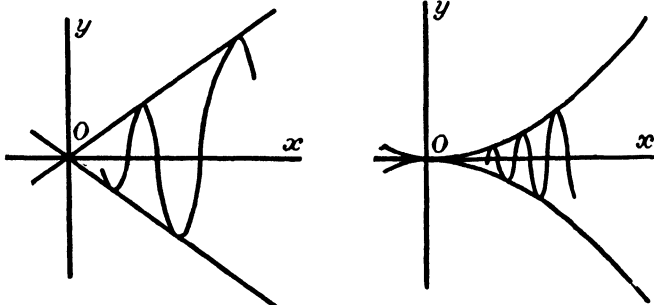

12. Let 
$$y = x^2 \cdot \sin \frac{\pi}{x} \text{ for } x \neq 0 \text{ and}$$

$$= 0 \text{ for } x = 0.$$

Here  $y$  is continuous everywhere, even at  $x = 0$ , and oscillates between the two parabolas  $y = \pm x^2$  and increasingly often as  $x \rightarrow 0$ . As a point on the curve approaches zero, a secant through this point and the origin oscillates between narrower

and narrower limits. These limits converge on both sides toward the  $x$ -axis. The tangent therefore at the origin is the  $x$ -axis.

Analytically:

$$\frac{\Delta y}{\Delta x} = \Delta x \cdot \sin \frac{\pi}{\Delta x} \text{ at } x = 0 \text{ and } \lim_{\Delta x \neq 0} \left[ \Delta x \cdot \sin \frac{\pi}{\Delta x} \right] = 0.$$

13. The function defined by  $f(x) = x \left\{ 1 + \frac{1}{3} \sin(\log x^2) \right\}$  and  $f(0) = 0$  is everywhere continuous and monotonic.

[PRINGSHEIM, *Encyklopädie der Math. Wissen.*, II A. 1, p. 22.]

Investigate whether this function has at  $x = 0$  a progressive or a regressive derivative or both, and, if both exist, whether they are the same.

14. Discuss Exs. 3–9 for progressive and regressive derivatives as in Ex. 13.

15. Given a rational function of  $x$ ,  $r(x) = \frac{g(x)}{h(x)}$  where  $g(x)$  and  $h(x)$  are polynomials. Show that in no case can the denominator of  $r'(x)$  be a *simple* factor as  $(x - a)$ .

Hence show that no rational function (such as  $1/x$ ) whose denominator contains any simple factor can be the derivative of another rational function.

16. The functions  $u, v$ , of  $x$  and their derivatives  $u', v'$  are continuous throughout a certain interval of values of  $x$ , and  $uv' - u'v$  never vanishes at any point of the interval. Show that between any two roots of  $u = 0$  occurs one of  $v = 0$ , and conversely.

[If  $v$  does not vanish between two roots of  $u = 0$ , say  $\alpha$  and  $\beta$ , the function  $u/v$  is continuous throughout the interval  $(\alpha, \beta)$  and vanishes at its extremities. Hence  $(u/v)' = (u'v - uv')/v^2$  must vanish between  $\alpha$  and  $\beta$ , which contradicts the hypotheses.]

17. The constituents' of an  $n$ th order determinant  $\Delta$  are functions of  $x$ . Show that its derivative is the sum of  $n$  determinants each of which is obtained from  $\Delta$  by substituting the derivatives of the elements of a row for the elements themselves.

18. If  $f_1, f_2, f_3, f_4$  are polynomials of degree not greater than 4, then

$$\begin{vmatrix} f_1 & f_2 & f_3 & f_4 \\ f_1' & f_2' & f_3' & f_4' \\ f_1'' & f_2'' & f_3'' & f_4'' \\ f_1''' & f_2''' & f_3''' & f_4''' \end{vmatrix}$$

is also a polynomial of degree not greater than 4. [Differentiate five times, using the result of Ex. 17 and rejecting vanishing determinants.]

19. If  $f(x), \phi(x), \psi(x)$  have derivatives for  $a \leq x \leq b$ , there is a value of  $\xi$ , lying between  $a$  and  $b$  and such that

$$\begin{vmatrix} f(a) & \phi(a) & \psi(a) \\ f(b) & \phi(b) & \psi(b) \\ f'(\xi) & \phi'(\xi) & \psi'(\xi) \end{vmatrix} = 0.$$

[Consider the function formed by replacing the constituents of the third row by  $f(x), \phi(x), \psi(x)$ .]

## CHAPTER IV

### SINGLE-VALUED ANALYTIC FUNCTIONS OF A COMPLEX VARIABLE

#### § 30. Introduction

WE have already introduced and investigated in part in Chapter II a series of elementary functions of a complex variable  $z$ . But at that time we postponed the discussion of the concept, "Function of a Complex Variable"; this will now be considered.

We can, to be sure, call  $X + iY$  in the most general sense a function of  $x + iy$  if the real expressions  $X, Y$  are functions of the real variables  $x$  and  $y$ . The theory of functions of a complex variable would then be nothing else than the theory of pairs of functions of two real variables. It is, however, customary to use the word in a narrower sense, so that the "Theory of Functions of a Complex Variable" represents only a particularly important and interesting chapter in the theory of pairs of functions of two real variables. The following considerations form a basis for this point of view:

The particular phrase, *rational function of a complex quantity*  $x + iy$ , has already been given a definite meaning in Chapter II on the basis of the definition of the elementary operations with complex quantities given in Chapter I. One might now be tempted to take as the basis for the definition of a transcendental function of a complex argument that definition of a

transcendental real function based on limits of rational functions — for example,

$$e^x = \lim_{n \rightarrow \infty} \left( 1 + \frac{x}{n} \right)^n.$$

But there are serious objections to this: it may happen that such limits exist for all real but for no complex values of  $x$ ; it may further happen that two such limits, which represent the same transcendental function when  $x$  is real, are different when  $x$  is complex. But, as a matter of fact, we shall soon see (§ 38) that such difficulties do not appear in a certain class of such functions, that is, for sums of infinite power series. Accordingly, WEIERSTRASS\* took the theory of power series as the basis of his theory of functions. CAUCHY and RIEMANN, on the contrary, began in general, not with an *analytical expression*, but with a definite *property* which belongs to every rational function of a complex variable but not to every expression  $X + iY$  whose members are rational functions of the real variables  $x, y$ . We shall follow the latter point of view here. It is essential therefore that we become acquainted with this distinctive property of rational functions of a complex variable; the following paragraphs are a preparation to that end.

### § 30 a. Limits of Convergent Sequences of Complex Numbers

The application of the conception of a convergent sequence of numbers to complex numbers raises no essential difficulties.

For, if

$$|x + iy| < \epsilon$$

then (cf. also I, § 25)

$$|x| < \epsilon \text{ and } |y| < \epsilon.$$

\* An authentic publication of the lectures of WEIERSTRASS has been promised for years. The work by J. THOMAE, *Elementare Theorie der analytischen Funktionen einer complexen Veränderlichen* (Halle, 1880, 2d ed. 1898), and that of Ch. MERAY, *Leçons nouvelles sur l'analyse infinitésimale* (Paris, 1894–1895), are written from the same point of view.

If therefore a sequence of complex numbers

$$z_0 = x_0 + iy_0, z_1 = x_1 + iy_1, z_2 = x_2 + iy_2, \dots z_n = x_n + iy_n, \dots$$

is so arranged that for every given degree of approximation  $\epsilon$  we can so determine an integer  $n$  that

$$(1) \quad |z_{n+p} - z_n| < \epsilon$$

for every  $p > 0$ , then

$$(2) \quad |x_{n+p} - x_n| < \epsilon, |y_{n+p} - y_n| < \epsilon$$

for the same value of the integer  $n$  and for every  $p > 0$ . Therefore the real and the pure imaginary parts of  $z$  form convergent sequences of numbers and the limits

$$(3) \quad \lim_{n \rightarrow \infty} x_n = a, \quad \lim_{n \rightarrow \infty} y_n = b$$

exist. Conversely, if inequalities (2) exist for a definite  $n$  and all values of  $p > 0$ , then the following inequality

$$(4) \quad |z_{n+p} - z_n| < \epsilon\sqrt{2}$$

exists under the same conditions. By putting  $a + ib = c$  we may combine the two limits (3) into one and define:

$$I. \text{ The limit} \quad \lim_{n \rightarrow \infty} z_n = c$$

shall be taken to signify the system of equations (3).

We extend this at once and write the definition (cf. A. A. § 53):

II. *An infinite series of complex quantities*

$$z_0 + z_1 + z_2 + \dots + z_n + \dots$$

is called convergent and the complex quantity  $S$  is called the sum of the series, when the limit

$$\lim_{n \rightarrow \infty} (z_0 + z_1 + z_2 + \dots + z_n)$$

exists and is equal to  $S$ .

The following is another formulation of the same definition :

III. *The necessary and sufficient condition for the convergence of an infinite series of complex quantities is, that the series of real parts and the series of imaginary parts respectively converge.*

We define further :

IV. *A series of complex quantities is called absolutely\* convergent when the series formed by its absolute values converges.*

On the basis of III, § 5 of this text and § 40, A. A., we then have the following theorem :

V. *If a series of complex quantities converges absolutely, then the series formed respectively from its real parts and from its imaginary parts converge absolutely ;*

and from this, on the basis of I, § 58, A. A., we state the more general theorem that :

VI. *The sum of an absolutely convergent series of complex quantities is independent of the arrangement of the terms.*

### § 31. Continuity of Rational Functions of a Complex Variable

For the sake of completeness we begin with the definition :

I. *A complex function of one or more real variables is a complex variable  $Z = X + iY$  whose components  $X, Y$  are functions of those variables.*

If there are two independent variables, say  $x, y$ , we can combine them as one complex variable  $z = x + iy$  and write

$$(1) \quad Z = f(z).$$

As a matter of fact we shall do this provisionally ; later this terminology will be used only in a more restricted sense.

\* Also called *unconditionally* convergent. The terms *absolutely* convergent and *unconditionally* convergent are co-extensive. — S. E. R.

The conception of *continuity* (§ 24; A. A. § 61) is applicable directly to complex functions on the basis of the definitions of § 30 a.

II. *A complex function is called continuous at a definite point  $z = a$  if the equation*

$$(2) \quad \lim_{n \rightarrow \infty} f(z_n) = f(a)$$

*exists for EVERY sequence of numbers for which*

$$(3) \quad \lim_{n \rightarrow \infty} z_n = a.$$

Comparison with § 26 shows this definition to be synonymous with the following:

*A function of a complex variable  $z = x + iy$  is said to be a continuous function of  $z$  only when it is, in the sense defined in § 26, III, a continuous function of the two real variables  $x$  and  $y$  (not, however, when it is a continuous function of  $x$  and a continuous function of  $y$ ).*

We proceed accordingly to apply the general conception of limits (A. A. § 62) to complex functions; thus:

III. *The equation*

$$(4) \quad \lim_{z \rightarrow a} f(z) = b$$

*means the same as*

$$(5) \quad \lim_{n \rightarrow \infty} f(z_n) = b$$

*for EVERY sequence of numbers converging to  $a$ .*

Therefore, a complex function is said to have at a certain point a definite value in the limit, only when this value is reached by the use of *arbitrary* values of approximation for the argument, or geometrically, if we approach the same value of the function by allowing the argument to approach its value along any curve whatever. To be sure, we have frequently to

consider approaching a limiting point not along arbitrary curves but only along particular ones, for example, approaching the origin along only such curves which do not encircle it an infinite number of times, or along only such as remain entirely in the positive half of the plane. Such limitations must then be expressly stated each time.

IV. *The theorem that the sum, difference, product, and quotient, providing the denominator is not zero, of two continuous functions are themselves continuous functions is true for complex variables as well as for real.*

For, the proof of this theorem rests only upon the two theorems (A. A. § 64) that the absolute value of a sum or difference is not greater than the sum of the absolute values of the separate parts, and that the absolute value of a product or of a quotient is equal respectively to the product or the quotient of their absolute values. But these two theorems hold for complex numbers as well as for real (III, § 5; I, § 6; II, § 7).

Since it follows directly from definition II that  $z$  itself is a continuous function of  $z$ , we obtain the theorem (cf. IV, § 26):

V. *A rational function of a complex variable is everywhere continuous where it is finite.*

We have therefore to consider only the results of § 20 by which a rational function can always be put in such a form that the denominator is zero only where the function is infinite.

It follows further from the results of § 20 that:

VI. *At the poles, at which a rational function itself is not continuous, its reciprocal at least is continuous.*

Theorems V and VI are understood to hold for finite values of the independent variables; but they are valid also for the value  $\infty$  according to §§ 12 and 21; that is,

VII. *Either a rational function or its reciprocal (or both) are continuous for  $z = \infty$ .*

Equations of the form

$$(6) \quad f(z_0) = \infty, f(\infty) = w_0, f(\infty) = \infty$$

were regarded in a purely conventional way in §§ 20 and 21 according to the meaning given to the symbol " $\infty$ " in § 12. However, such equations can be interpreted in a different way (A. A. § 63) which is applicable to complex variables as follows:

VIII.  *$f(z_0) = \infty$  means that for every given number  $M > 0$  another number  $\delta$  can be determined such that*

$$|f(z_0 + \zeta)| > M, \text{ whenever } |\zeta| < \delta.$$

IX.  *$f(\infty) = w_0$  means that for every given number  $\epsilon > 0$  another number  $N$  can be determined such that*

$$|f(z) - w_0| < \epsilon, \text{ whenever } |z| > N.$$

X.  *$f(\infty) = \infty$  means that for every given number  $M > 0$  another number  $N$  can be determined such that*

$$|f(z)| > M, \text{ whenever } |z| > N.$$

Theorems VI and VII then assert that:

XI. *These two views of the symbol  $\infty$  as applied to rational functions are not contradictory; and every such equation (6) which is true from the one point of view is also true from the other.*

Geometrically, the theorems of this paragraph assert that:

XII. *The map of the  $z$ -sphere upon the  $w$ -sphere determined by a rational function  $w = f(z)$  is everywhere continuous, even in the vicinity of the point  $\infty$  of both spheres.*

Further, we are always to understand that also the second and third of equations (6) are valid when the point of the sphere representing the independent variable approaches the point  $\infty$  of the sphere along any *arbitrary* curve. When specially considering such curves it must be so stated each time, as, for example, when it is to be merely affirmed that a definite value is reached in the limit as the independent variable increases through positive real values beyond all bounds.

### § 32. Derivative of a Rational Function of a Complex Argument

To pursue further the investigation spoken of at the close of § 30, we study the quotient

$$(1) \quad \frac{f(z_0 + \zeta) - f(z_0)}{\zeta} = \psi(\zeta),$$

as a function of  $\zeta$  and for a definite value  $z_0$  of  $z$  for which the rational function  $f(z)$  is finite. It is a rational function of  $\zeta$  which takes the indeterminate form  $\frac{0}{0}$  for  $\zeta = 0$ . But it has already been shown in § 20 that such an indeterminate form of a rational function of  $\zeta$  can always be evaluated by a suitable reduction. In other words, we can always find another rational function  $\psi_1(\zeta)$  which agrees with  $\psi(\zeta)$  for all those values of  $\zeta$  for which  $\psi(\zeta)$  is determinate, but which for  $\zeta = 0$  either has a definite value or is definitely infinite in the sense defined there. Now it is shown in the differential calculus (cf. also § 27) that, restricting  $z_0$  and  $\zeta$  to real values, this function  $\psi_1(\zeta)$  under the given assumptions does have a definite value for  $\zeta = 0$  and that this value is a rational function of  $z_0$  which is designated by

$$f'(z_0)$$

and which is customarily called the derivative of  $f(z)$ . But in this way  $f(z)$  is supposed real at the outset; however, the same

process is applicable here by dividing  $\psi(\zeta)$  into its real and imaginary parts :

$$(2) \quad \psi(\zeta) = \phi(\zeta) + i\chi(\zeta)$$

and treating each of these parts separately. It then follows that the quotient  $\psi(\zeta)$ , under the assumption that  $f(z_0) \neq \infty$  for  $\zeta = 0$ , has a definite value  $f'(z_0)$  in the limit (and dependent upon  $z_0$ ) when  $\zeta$  is restricted to real values. But we have seen in the preceding paragraphs that a *rational* function of a complex variable  $\zeta$  is everywhere continuous where it is finite; if therefore

$$\lim_{\zeta \neq 0} \frac{f(z_0 + \zeta) - f(z_0)}{\zeta} = f'(z_0)$$

whenever  $\zeta$  approaches zero through real values, it follows for *rational* functions  $f$ , that this equation must hold *in whatever manner*  $\zeta$  converges to zero. These results are stated in the following theorem :

I. *A rational function  $f(z)$  of a complex variable has at every point  $z$  at which it is finite a definite derivative,*

$$(3) \quad \frac{df(z)}{dz} = f'(z),$$

*independent of the manner in which  $dz$  approaches zero and which can be found by the methods of the differential calculus for real variables and functions.*

It is now easy to see that this property does not belong to every expression  $u + iv$ , whose members are rational functions of  $x$  and  $y$ . For, the total variation of such an expression is, according to elementary theorems of the differential calculus for functions of two variables,

$$\Delta u + i\Delta v = \left( \frac{\partial u}{\partial x} + i \frac{\partial v}{\partial x} + \epsilon_1 \right) \Delta x + \left( \frac{\partial u}{\partial y} + i \frac{\partial v}{\partial y} + \epsilon_2 \right) \Delta y$$

where  $\epsilon_1, \epsilon_2$  designate quantities that approach zero with  $\Delta x$  and  $\Delta y$ . The quotient

$$\frac{\Delta u + i\Delta v}{\Delta x + i\Delta y}$$

can then be written

$$\frac{\left(\frac{\partial u}{\partial x} + i\frac{\partial v}{\partial x} + \epsilon_1\right) + \left(\frac{\partial u}{\partial y} + i\frac{\partial v}{\partial y} + \epsilon_2\right)\frac{\Delta y}{\Delta x}}{1 + i\frac{\Delta y}{\Delta x}}$$

If we now allow  $\Delta x$  and  $\Delta y$  to approach zero in such a way that  $\frac{\Delta y}{\Delta x}$  converges to a definite value\*  $\frac{dy}{dx}$  in the limit, that is, geometrically, if we allow the point  $(x + \Delta x, y + \Delta y)$  to approach the point  $(x, y)$  along a curve which has a definite tangent at  $(x, y)$ , then the above quotient converges in the limit to

$$\frac{\left(\frac{\partial u}{\partial x} + i\frac{\partial v}{\partial x}\right) + \left(\frac{\partial u}{\partial y} + i\frac{\partial v}{\partial y}\right)\frac{dy}{dx}}{1 + i\frac{dy}{dx}}$$

In general this expression depends essentially upon  $\frac{dy}{dx}$  in the limit; it will be independent of  $\frac{dy}{dx}$  when and only when the term free from  $\frac{dy}{dx}$  in the numerator (as in the denominator) has the ratio  $1 : i$  to the coefficient of  $\frac{dy}{dx}$ , in other words, when

$$(4) \quad \frac{\partial u}{\partial y} + i\frac{\partial v}{\partial y} = i\left(\frac{\partial u}{\partial x} + i\frac{\partial v}{\partial x}\right).$$

But this equation is true (I, § 2) when and only when

$$(5) \quad \begin{cases} \frac{\partial u}{\partial y} = -\frac{\partial v}{\partial x} \text{ and} \\ \frac{\partial v}{\partial y} = \frac{\partial u}{\partial x}. \end{cases}$$

\* Which may also be  $\infty$ .

We have thus the result :

II. *An expression of the form  $u + iv$ , in which  $u, v$ , are rational functions of  $x$  and  $y$ , can only be put in the form of a rational function of  $z = x + iy$  when  $u$  and  $v$  satisfy the partial differential equations (5).*

On the other hand, it is to be noticed that the formal rules for the differentiation of *rational* functions are simple consequences of fundamental theorems of elementary algebra. Since we have shown in the first chapter that these fundamental theorems hold for complex expressions as well as for real, it follows that we may also apply these rules of differentiation to *rational* functions of a complex variable. Thus, for example, in such a function, considered as a function of  $x$  and  $y$ , we can introduce  $z = x + iy$  in place of  $x$  as independent variable along with  $y$ ; let us then distinguish the partial derivatives taken with respect to these independent variables from those taken with respect to  $x$  and  $y$  as independent variables by inclosing them in parenthesis. Thus, according to these rules :

$$(6) \quad \frac{\partial f}{\partial x} = \left(\frac{\partial f}{\partial z}\right); \quad \frac{\partial f}{\partial y} = \left(\frac{\partial f}{\partial y}\right) + i\left(\frac{\partial f}{\partial z}\right).$$

If now we have a complex expression  $u + iv$ , whose members are rational functions of  $x$  and  $y$  and which satisfies equation (4) and if we replace  $f$  in (6) by it, it follows that

$$\left(\frac{\partial(u + iv)}{\partial y}\right) = \frac{\partial(u + iv)}{\partial y} - i \frac{\partial(u + iv)}{\partial x} = 0.$$

When, therefore,  $z = x + iy$  is introduced in place of  $x$  along with  $y$  as a new independent variable in a complex expression of the given form satisfying equation (4),  $y$  itself drops out; in other words :

III. *If  $u$  and  $v$  are rational functions of  $x$  and  $y$ , then the existence of equations (5) is not only a necessary but is also a sufficient condition that  $u + iv$  can be put in the form of a rational function of  $z$  alone.*

### § 33. Definition of Regular Functions of a Complex Argument

The property of *rational* functions of a complex variable deduced in the last paragraph will now be taken as the starting point for the determination of a general definition of a function of a complex argument :

I.  *$w = f(z)$  shall be called a (regular) function of a complex argument  $z$  in a given domain, only when the limit*

$$(1) \quad \lim_{\xi \rightarrow 0} \frac{f(z + \xi) - f(z)}{\xi}$$

*exists in the sense defined in III, § 31 for every point  $z$  of this domain.*

The symbol  $f(z)$  will be used exclusively hereafter for such regular functions of  $z$ , and the limit (1) will be designated by  $\frac{df(z)}{dz}$  or  $f'(z)$  just as for real variables and functions.\*

If the function  $w = u + iv$

be separated into its real and imaginary parts and if the functions  $u, v$  have continuous partial derivatives, then the results of § 32 show that the limit (1) is independent of the manner in which  $z$  approaches zero only when these partial derivatives satisfy equations (5), § 32. Conversely, reviewing these results starting with the last, it follows that these equations together

\* To indicate that a function  $w = f(z)$  has the property that  $\frac{\Delta w}{\Delta z}$  tends, in general, to a unique finite limit, that is, that it satisfies (5), § 32, CAUCHY employed the term *monogenic*, while RIEMANN dispensed with the adjective altogether. Cf. RIEMANN, *Ges. Werke*, pp. 5, 81. — S. E. R.

with the assumption of continuity of the partial derivatives appearing in them are sufficient to infer the existence of limit (1) in the established sense. On this account CAUCHY and RIEMANN made use of these differential equations as the definition of functions of a complex argument.

Besides, we notice that, in passing from the differential equations to the limit (1) and conversely, it was necessary to assume the continuity of the partial derivatives which appeared; on the contrary we shall see that in the further application of the limit (1), we need only assume its existence for each point of the domain, not its continuity as a function of  $z$ . This continuity follows rather as a consequence of the above assumptions.

An example of a regular, but not rational function of a complex argument is obtained by putting

$$u = e^x \cos y, \text{ and } v = e^x \sin y;$$

for, from these equations, we find

$$\frac{\partial u}{\partial x} = \frac{\partial v}{\partial y} = e^x \cos y, \quad \frac{\partial u}{\partial y} = -\frac{\partial v}{\partial x} = -e^x \sin y.$$

Thus,  $e^x(\cos y + i \sin y)$  is a function of  $z = x + iy$ , regular over the whole plane.

Definition I does not in general require the existence or continuity of *higher* derivatives (but we shall see later that they can be inferred from this definition). But if this result is assumed repeated differentiation of the differential equations (5), § 32, leads to the following results:

$$(2) \quad \frac{\partial^2 u}{\partial x^2} + \frac{\partial^2 u}{\partial y^2} = \frac{\partial^2 v}{\partial x \partial y} - \frac{\partial^2 v}{\partial y \partial x} = 0,$$

$$(3) \quad \frac{\partial^2 v}{\partial x^2} + \frac{\partial^2 v}{\partial y^2} = -\frac{\partial^2 u}{\partial x \partial y} + \frac{\partial^2 u}{\partial y \partial x} = 0;$$

hence the following theorem :

II. *Neither the real nor the pure imaginary part of an analytic function of a complex argument can be assumed to be arbitrary functions of  $x$  and  $y$ ; on the contrary, each must satisfy the corresponding "LAPLACE" differential equation :*

$$\frac{\partial^2 u}{\partial x^2} + \frac{\partial^2 u}{\partial y^2} = 0; \quad \frac{\partial^2 v}{\partial x^2} + \frac{\partial^2 v}{\partial y^2} = 0.$$

#### EXAMPLES

1. An example exhibiting a function whose derivative at a point is not independent of the manner of approaching this point is the following :

Let  $w = u + iv = 2x + 3iy$  be the function, and let us examine it at a point  $(x, y)$ . At a neighboring point we obtain

$$w + \Delta w = u + \Delta u + i(v + \Delta v) = 2(x + \Delta x) + i3(y + \Delta y).$$

$$\therefore \Delta u = 2 \Delta x, \quad \Delta v = 3 \Delta y.$$

The derivative at a point  $(x, y)$  therefore becomes

$$\lim_{\substack{\Delta x \neq 0 \\ \Delta y \neq 0}} \left[ \frac{\Delta u + i\Delta v}{\Delta x + i\Delta y} \right] = \lim_{\substack{\Delta x \neq 0 \\ \Delta y \neq 0}} \left[ \frac{2 \Delta x + i3 \Delta y}{\Delta x + i\Delta y} \right] = \frac{2 + 3i \frac{dy}{dx}}{1 + i \frac{dy}{dx}}.$$

The value of this derivative can be made to assume any arbitrary value by suitably choosing  $\frac{dy}{dx}$ . This process does *not* therefore define a derivative independent of the manner of approaching the given point.

Show directly that  $w = 2x + 3iy$  is not a regular function.

2. If  $u = (x - 1)^3 - 3xy^2 + 3y^2$ , determine  $v$  so that  $u + iv$  is a regular function of  $x + iy$ .

$$\text{Ans. } v = 3y(x - 1)^2 - y^3, \text{ that is, } w = (z - 1)^3.$$

3. If  $u = x^3$ , is it possible to determine  $v$  so that the function is regular?

4. Given  $v = 2y(x + 1)$ ; determine the corresponding  $u$  so that  $u + iv$  shall be a regular function.

5. Given  $u = x^3 - 3xy^2$ ; find the corresponding  $v$  as in Ex. 3.

6. Given  $u = e^{x^2-y^2} \cdot \cos 2xy$ ; find  $v$  and the resulting function of  $z$  as in Ex. 3.

7. Prove by passing directly to the limit that in polar coördinates the CAUCHY-RIEMANN differential equations take the form:

$$\begin{cases} \frac{\partial u}{\partial r} = \frac{1}{r} \cdot \frac{\partial v}{\partial \phi}, \\ \frac{\partial v}{\partial r} = -\frac{1}{r} \cdot \frac{\partial u}{\partial \phi}. \end{cases}$$

Also, show that

$$\frac{dw}{dz} = e^{-\phi i} \cdot \frac{\partial w}{\partial r} = \frac{e^{-(\phi + \frac{\pi}{2})i}}{r} \cdot \frac{\partial w}{\partial \phi}.$$

8. Show that the function

$$w = \log r + i\phi,$$

where  $z = r(\cos \phi + i \sin \phi)$ , is regular at every point  $z$  different from 0 and  $\infty$ . (Cf. § 56.)

9. If a function

$$f(x + iy) = R(\cos \theta + i \sin \theta)$$

is regular in a definite domain, then

$$\frac{\partial R}{\partial x} = R \cdot \frac{\partial \theta}{\partial y}, \quad \frac{\partial R}{\partial y} = -R \cdot \frac{\partial \theta}{\partial x},$$

and

$$\frac{f'(z)}{f(z)} = \frac{\partial \log R}{\partial x} + i \cdot \frac{\partial \theta}{\partial x}.$$

Derive also the corresponding relations for the case where  $z$  is expressed in the form  $z = r \cdot e^{i\theta}$ .

## § 34. Conformal Representation

We have already investigated in § 27 the mapping of a domain of the  $xy$ -plane continuously on a region of the  $uv$ -plane. A particular class of such transformations are those for which  $w + iv$  is a regular function of  $x + iy$  in the sense defined in the previous paragraph; we wish to characterize this class of transformations geometrically.

For this purpose we rearrange the preceding results somewhat. Let  $z_1, z_2, z_3$  be three values of  $z = x + iy$ ,  $w_1, w_2, w_3$  the corresponding values of  $w = u + iv$ , and form the quotients

$$\frac{w_2 - w_1}{z_2 - z_1} \quad \text{and} \quad \frac{w_3 - w_1}{z_3 - z_1}.$$

As  $z_2$  and  $z_3$  approach  $z_1$ , these two quotients differ by an infinitesimal\*; for, each of them differs by an infinitesimal from the definite, unique value of the derivative:

$$\frac{dw}{dz}$$

at the point  $z = z_1$ . Accordingly,

$$(1) \quad \frac{w_2 - w_1}{z_2 - z_1} = \frac{w_3 - w_1}{z_3 - z_1} + \epsilon,$$

where  $\epsilon$  becomes infinitesimal with  $z_2 - z_1$  and  $z_3 - z_1$ . Conversely, when such an equation exists, in whatever way  $z_2$  and  $z_3$  may approach the point  $z_1$ , it follows that the derivative  $\frac{dw}{dz}$  is independent of the direction of the differential  $dz$ .

Apart from an exception to be spoken of presently (VI), we can draw the general conclusion from equation (1), that also in

\* We shall understand that no constant, however small, if not zero, is an infinitesimal; the essence of the infinitesimal is that it varies so as to approach zero as a limit. Cf. GOURSAT-HEDRICK, *Mathematical Analysis*, Vol. 1, p. 19. — S. E. R.

the equation

$$(2) \quad \frac{w_2 - w_1}{w_3 - w_1} = \frac{z_2 - z_1}{z_3 - z_1} + \epsilon'$$

$\epsilon'$  becomes infinitesimal with  $z_2 - z_1$  and  $z_3 - z_1$ . If  $\epsilon'$  is omitted in this equation, we obtain (except for the symbols) equation (17) of § 10, whose geometrical significance was discussed there. We thus have an answer to the proposed question; it can be formulated as follows:

I. *If  $w$  is a regular function of  $z$ , then every triangle of the  $z$ -plane whose sides are infinitesimals of the same order, is similar to the corresponding triangle of the  $w$ -plane up to infinitesimals of higher order, that is, ratio of sides and angles of the one differ only by infinitesimals from the corresponding parts of the other.*

In particular, if we apply the results of § 10 for the finite triangles discussed there to the infinitesimal triangles just mentioned, it follows that:

II. *The absolute value of the derivative  $\frac{dw}{dz}$  at a point of the  $z$ -plane gives the scale of similarity\* at that point, that is, gives the factor by which the length of an infinitesimal arc of the  $z$ -plane must be multiplied in order to obtain the length of the corresponding arc of the  $w$ -plane.*

III. *The amplitude  $\alpha$  of  $\frac{dw}{dz}$  gives the angle through which each element of arc at the point  $z$  must be turned in order to be made parallel to the corresponding element of arc of the  $w$ -plane.*

Since this angle depends only upon the point  $z$ , and not upon the direction of the element of arc, it follows that

IV. *Any two curves of the  $z$ -plane form with each other at each of their points of intersection, the same angle as the corresponding curves of the  $w$ -plane at the corresponding points of intersection;*

\* Sometimes called the *cartographic modulus*.—S. E. R.

or (by using the terminology introduced in VII, § 11):

V. *A domain of the  $z$ -plane in which a regular function  $w$  with a complex argument  $z$  is defined, is mapped conformally by means of this function on a region of the  $w$ -plane.*

We have already become acquainted with a large number of such representations in Chapter II; in what follows we shall find many others.

The inference from (1) to (2) is only permissible when the limit of  $\left(\frac{z_2 - z_1}{w_3 - w_1}\right)$  is finite, and hence that of  $\left(\frac{w_3 - w_1}{z_2 - z_1}\right)$  is different from zero. Since we have to do here only with triangles all of whose sides are infinitesimals of the same order, this inference is true when and only when

$$\lim_{z_2 \rightarrow z_1} \left(\frac{w_2 - w_1}{z_2 - z_1}\right) = \left(\frac{dw}{dz}\right)_{z=z_1}$$

is different from zero. Consequently, the following corollary must be added to Theorem II:

VI. *The conformality of the representation is not established at those places at which*

$$\frac{dw}{dz} = 0.$$

The relation which the angle at such a point in the one plane bears to the corresponding angle in the other plane will be discussed in § 69.

In many cases it is of interest to notice what curves of the  $w$ -plane correspond to the parallels to the coördinate axes of the  $z$ -plane. The equations of these curves are obtained if we put  $w = f(z) = \phi(x, y) + i\psi(x, y)$  and then eliminate  $x$  and  $y$  respectively from the equations:

$$(3) \quad \phi(x, y) = u, \quad \psi(x, y) = v.$$

Conversely, the equations

$$(4) \quad \phi(x, y) = \text{const.}$$

and

$$(5) \quad \psi(x, y) = \text{const.}$$

represent those systems of curves of the  $z$ -plane, to which the parallels to the coördinate axes of the  $w$ -plane correspond. Since the representation is conformal, every curve of the system (4) intersects every curve of system (5) at right angles. The two systems of curves are *orthogonal* to each other.

Further, if we choose from the systems of parallels to the coördinate axes in the  $w$ -plane such a distinct set, the lines of which are at the same constant distance from each other in both systems, they will divide the  $w$ -plane into squares; these correspond to divisions of the  $z$ -plane, which differ less and less from squares, the smaller that constant distance is chosen. This property of the systems (4) and (5) is usually expressed more briefly by saying: *They divide the  $z$ -plane into indefinitely small squares.* A system of curves, for which a second system can be found such that the two together divide the plane (or in general any surface) into indefinitely small squares, is called an *isometric* or an *isothermal* system.

This latter terminology is well suited to the physical interpretation of such a system of curves which we must at least mention. Let us suppose a (ponderable or imponderable) fluid flowing in the  $xy$ -plane, and let  $\xi$ ,  $\eta$  be the  $x$ - and  $y$ -components of its velocity at some point  $(x, y)$ . Let us fix in mind a rectangle whose sides are parallel to the coördinate axes and having the distances  $x$ ,  $x + dx$ ,  $y$ ,  $y + dy$  respectively from them. In the time  $dt$ , the mass  $\xi dt dy$  will flow in over the side  $(x)$ , and during the same time there flows out over the opposite side the mass of liquid  $\left(\xi + \frac{\partial \xi}{\partial x} dx\right) dt dy$ . Likewise over the side  $(y)$ , the mass

$\eta dt dx$  comes in; over the opposite side  $(\eta + \frac{\partial \eta}{\partial y} dy) dt dx$  goes out. Therefore, in the time  $dt$  the mass of liquid contained in the rectangle  $dx dy$  is increased by

$$-\left(\frac{\partial \xi}{\partial x} + \frac{\partial \eta}{\partial y}\right) dt dx dy.$$

If the liquid be regarded as incompressible, an increase or a decrease in the mass of the liquid contained in the rectangle cannot take place and hence it must follow that

$$(6) \quad \frac{\partial \xi}{\partial x} + \frac{\partial \eta}{\partial y} = 0.$$

And if  $\xi$ ,  $\eta$  are the derivatives of one and the same function  $v(x, y)$  (the "velocity potential")\* with respect to the co-ordinates, that is,

$$\xi = \frac{\partial v}{\partial x}, \quad \eta = \frac{\partial v}{\partial y},$$

it follows that

$$(7) \quad \frac{\partial \xi}{\partial y} - \frac{\partial \eta}{\partial x} = 0.$$

The two equations (6) and (7) together tell us that  $\zeta = \eta + i\xi$  is a function of the complex argument  $z = (x + iy)$ ; and that  $i v$  is the imaginary part of the function  $\int \zeta dz$  (defined in the next section). If  $u$  be taken as the real part of this function, it follows that

$$(8) \quad \xi = -\frac{\partial u}{\partial y}, \quad \eta = \frac{\partial u}{\partial x};$$

in other words, the direction of the velocity at any point coincides with the tangent to the curve  $u = \text{const.}$  going through this point. These curves are then the lines of flow. We thus find that:

\* Cf. HARKNESS AND MORLEY, *Introduction*, etc. p. 315; OSGOOD, *Lehrbuch der Funktionentheorie*, Vol. I, chap. 13. — S. E. R.

The "lines of level" (lines of equipotential)  $v = \text{const.}$  and the "lines of flow"  $u = \text{const.}$  for a constant current of an incompressible fluid in the plane, which has a velocity potential, together divide the plane into indefinitely small squares.

Conversely, if we have given a regular function  $w = u + iv$  of the complex variable  $z = x + iy$ , we can always look upon the curves  $u = \text{const.}$ ,  $v = \text{const.}$  as lines of flow and lines of level for a constant non-rotating current of an incompressible fluid in this part of the plane.

For transmission of heat, temperature takes the place of velocity potential; for the transmission of electricity, the term electrical potential is used.

#### EXAMPLES

1. The lines of flow and lines of level are sometimes called path-curves and niveau lines respectively. We may define a *path-curve* of a linear transformation to be any curve in the plane which is transformed into itself by the transformation. This does not imply that the points on the curve remain fixed.

A system of *niveau lines* is a set of lines each of which is transformed into the next of the set. The niveau lines are usually but not necessarily chosen so as to meet the path-curves at right angles.

For the transformation  $z' = z + a$ , the path-curves are the lines parallel to  $\overline{oa}$  ( $o$  is the origin), and a set of niveau lines is the line through  $o$  perpendicular to  $\overline{oa}$  and the lines parallel to it, at distances  $|oa|$  from each other.

For  $z' = az$ , first let  $a$  be real. The path-curves are then the lines through  $o$  and a system of niveau lines is the set of circles with  $o$  as center and radii  $k, ka, ka^2, ka^3, \dots, ka^n$ , where  $k$  has any real value. Second, let  $|a| = 1$ . The figure in the preceding case is reversed, path-curves becoming niveau lines and *vice versa*.

*Third*, let  $|a| \neq 1$  and  $\text{am } a \neq 0$ . In this case the path-curves are logarithmic spirals with centers at  $o$  whose equations are

$$\theta = \frac{\text{am } a}{\log |a|} \cdot \log r + n,$$

where  $n$  has any real value. The corresponding niveau lines are the log spirals

$$- \theta = \frac{\log |a|}{\text{am } a} \cdot \log r + n.$$

Cf. HARKNESS AND MORLEY, *Introduction*, pp. 55, 56.

2. What curves of the  $w$ -plane correspond by the transformation  $w = \frac{z+1}{z}$  to the lines  $x=0, \pm 1, y=0, \pm 1$ , and to the unit circle of the  $z$ -plane?

### § 35. The Integral of a Regular Function of a Complex Argument

I. *The integral of a complex function  $u + iv$  with respect to a real variable  $t$  between the real limits  $a, b$*

$$(1) \quad \int_a^b (u + iv) dt,$$

*we understand to be* (cf. § 28);

$$\int_a^b u dt + i \int_a^b v dt.$$

But what is to be understood by an integral between complex limits requires some explanation. A *real* variable of integration can pass from its lower to its upper limit (through *one* sequence of intermediate values) along only *one* path (providing the path does not pass through infinity and that it is not retraced anywhere along it). On the contrary, we can pass from

one value of a *complex* variable to another through many different sequences of intermediate values; we can connect two points of the plane, upon which they are represented geometrically, by many different curves. Therefore, in speaking of an integral between complex limits, we must necessarily fix upon a *path of integration* and regard the integral as a curvilinear integral of the kind defined in § 29. Accordingly,

II. *If there is given a path  $\Gamma$  connecting the points  $z_0 = x_0 + iy_0$  and  $z_1 = x_1 + iy_1$ , and if upon this path  $w = u + iv$  is a continuous complex function of  $x$  and  $y$ , then we understand*

$$(2) \quad \int_{\Gamma} w dz$$

to be the integral

$$\int_{\Gamma} (u + iv)(dx + idy) = \int_{\Gamma} (u dx - v dy) + i \int_{\Gamma} (v dx + u dy).$$

The question frequently arises whether there is an upper limit to the absolute value of a complex integral. In this connection Theorem IV of § 5 will aid us; it follows from it that

$$(3) \quad \left| \int w dz \right| \leq \int |w| |dz|,$$

in which  $|dz|$  is the element of arc of the path of integration; the right-hand side is therefore  $\leq ML$ ,

where  $M$  is the maximum of  $w$  on the path of integration and  $L$  the length of this path.

For example, between the limits  $z_0$  and  $z$  (cf. VI, § 29),

$$\begin{aligned} \int dz &= \int dx + i \int dy = x - x_0 + i(y - y_0), \\ \int z dz &= \int (x dx - y dy) + i \int (x dy + y dx) \\ &= \frac{1}{2}(x^2 - y^2) + ixy - \left[ \frac{1}{2}(x_0^2 - y_0^2) + ix_0 y_0 \right] \end{aligned}$$

for any arbitrary path of integration. These two integrals are thus independent of the path. As a direct consequence of VI, § 29, the following general theorem holds:

III. *If  $f(z)$  is the derivative of a function  $F(z)$  of  $z$  regular in a simply connected domain  $B$ , then*

$$\int_{z_0}^{z_1} f(z) dz = F(z_1) - F(z_0)$$

*however the path from  $z_0$  to  $z_1$  inside this domain may be chosen.*

Further, the following theorem holds:

IV. *If a function  $f(z)$  of a complex argument is regular in a simply connected domain  $B$ , then*

$$(4) \quad \int_{\Gamma} f(z) dz = 0$$

*for every closed curve which lies entirely inside of  $B$ .\**

For, according to hypothesis,

$$\lim_{\zeta \neq 0} \frac{f(z_0 + \zeta) - f(z_0)}{\zeta} = f'(z_0)$$

for every point  $z_0$  of the domain; a neighborhood about every such point can then be so chosen that

$$\left| \frac{f(z_0 + \zeta) - f(z_0)}{\zeta} - f'(z_0) \right| < \epsilon$$

for all points  $z_0 + \zeta$  of this neighborhood; hence if we put

$$f(z_0 + \zeta) = f(z_0) + \zeta f'(z_0) + \zeta \eta,$$

$\eta$  is a function of  $z$  and  $\zeta$  respectively, whose absolute value is smaller than  $\epsilon$  for all points of the neighborhood of  $z$ . Inte-

\* Many proofs have been given of this fundamental theorem in the theory of functions. The reader will be interested in comparing the proof given here with the one due to GOURSAT, *Acta Math.*, Vol. IV, p. 197. — S. E. R.

grating now about a square whose length of side is  $\delta$  and which belongs entirely to this neighborhood, introducing  $\zeta$  as variable of integration, we obtain :

$$\int f(z) dz = f(z_0) \int d\zeta + f'(z_0) \int \zeta d\zeta + \int \zeta \eta d\zeta.$$

The first two integrals on the right-hand side are equal to zero and the last is in absolute value less than  $\delta \cdot \sqrt{2} \cdot \epsilon \cdot 4 \delta$ , that is,

$$< 4 \sqrt{2} \delta^2 \epsilon.$$

But from this according to IX, § 29, it follows that the integral taken over any closed curve lying entirely inside of  $B$  is zero.

Q.E.D.

If, therefore, we have two paths  $ABC$  and  $ADC$  inside of this domain  $B$  and between the same two points  $A$  and  $C$  (cf. Fig. 15), it follows that

$$\int_{ABC} f(z) dz + \int_{CDA} f(z) dz = 0$$

or (by II, § 29) :  $\int_{ABC} f(z) dz = \int_{ADC} f(z) dz,$

that is, the following form of Theorem III is also true :

V. *If we consider only such paths of integration which lie entirely within a simply connected domain  $B$  in which the function  $f(z)$  is regular, then the value of the integral*

$$(5) \quad \int_{z_0}^{z_1} f(z) dz$$

*is independent of the path, dependent only upon the initial- and end-points  $z_0$  and  $z_1$ .*

If we keep the end-point fixed, we can regard the value of the integral in the sense of definition I, § 31, as a complex function of the upper limit and as such designate it by  $F(z_1)$ . To obtain then the value of this function for a neighboring argument  $z_1 + \zeta$

(which also belongs to this domain), we can take as the path of integration from  $z_0$  to  $z_1 + \zeta$  any suitable path from  $z_0$  through  $z_1$  since the value of the integral is independent of the path; we thus obtain :

$$F(z_1 + \zeta) = \int_{z_0}^{z_1} f(z) dz + \int_{z_1}^{z_1 + \zeta} f(z) dz = F(z_1) + f(z_1) \int_{z_1}^{z_1 + \zeta} dz \\ + \int_{z_1}^{z_1 + \zeta} [f(z) - f(z_1)] dz.$$

Since  $f(z)$  is by hypothesis continuous,  $\zeta$  can be taken so small that

$$|f(z) - f(z_1)| < \epsilon$$

for all points of the path from  $z_1$  to  $z_1 + \zeta$ ; then, according to (3):

$$(6) \quad |F(z_1 + \zeta) - F(z_1) - \zeta f(z_1)| < \epsilon |\zeta|$$

and, therefore, in whatever manner  $\zeta$  converges to zero,

$$(7) \quad \lim_{\zeta \rightarrow 0} \frac{F(z_1 + \zeta) - F(z_1)}{\zeta} = f(z_1),$$

that is, according to I, § 33 :

VI. *Under the hypotheses of Theorem V, the value of an integral is a regular function of its upper limit: and its derivative is the function to be integrated.*

We add further the corollary :

VII. *If two curves  $\Gamma, \gamma$  inclose an annular domain  $B$  in which the function  $f(z)$  satisfies the conditions of Theorem III, then*

$$(8) \quad \int_{\Gamma} f(z) dz = \int_{\gamma} f(z) dz$$

*provided we pass along the curves so that the area inclosed by each of them always lies to the left.*

To prove this theorem let us think of the domain  $B$  cut along a line  $C$  which connects a point  $a$  of  $\gamma$  with a point  $A$  of  $\Gamma$ . By this means we obtain a simply connected domain  $B$ . To pass now around these boundaries keeping the domain  $B$  always to our left, we proceed as follows along

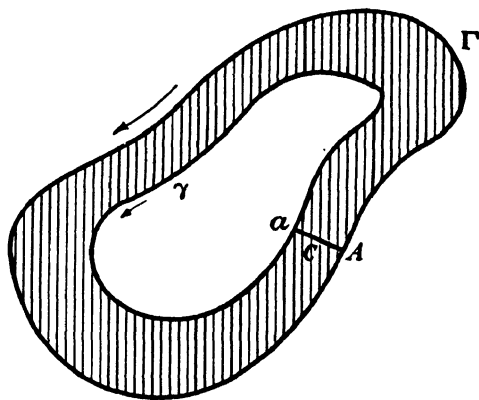

FIG. 16

1. The curve  $\Gamma$  in the direction of the arrow;
2. The curve  $C$  from  $A$  to  $a$ ;
3. The curve  $\gamma$  opposite to the direction of the arrow;
4. The curve  $C$  from  $a$  to  $A$ .

The sum of the integrals taken along these four curves is, according to Theorem V, equal to zero. But since the second of these four integrals is equal but opposite in sign to the fourth, it follows that :

$$\int_{\Gamma} f(z) dz + \int_{\gamma} f(z) dz = 0$$

when the integral is taken along the two curves as above indicated. But in Theorem VII the direction on  $\gamma$  was opposite to this, on account of which we must there use the opposite sign.

As an example of the methods of this paragraph, let us treat the problem to determine the value of the integral :

$$\int_{\Gamma} (z - \zeta)^n dz$$

taken along any curve  $\Gamma$  inclosing the point  $\zeta = \xi + i\eta$ , when  $n$  is a positive or negative integer. Let us draw about  $\zeta$  a circle  $C$

with a radius so small that it lies entirely inside of  $\Gamma$ . In the domain between  $C$  and  $\Gamma$ , the function  $(z - \zeta)^n$  (even if  $n$  is negative) is regular, and, therefore, according to VI :

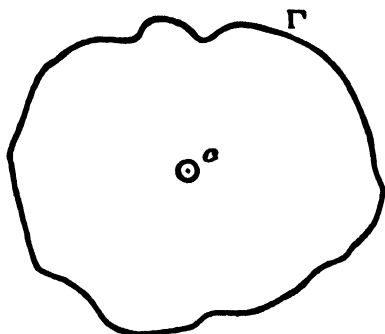

FIG. 17

$$\int_{\Gamma} (z - \zeta)^n dz = \int_C (z - \zeta)^n dz.$$

But the value of the integral taken over the circle can be found from definition I ; let us put :

$$x - \xi = r \cos t$$

and  $y - \eta = r \sin t,$

whence

(8a)  $z - \zeta = r(\cos t + i \sin t),$

(9)  $dz = r(-\sin t + i \cos t)dt$

$$= ir(\cos t + i \sin t)dt = i(z - \zeta)dt,$$

and therefore the point passes around the circle exactly once as  $t$  increases from 0 to  $2\pi$ . We then obtain :

$$\int_C (z - \zeta)^n dz = r^{n+1} \cdot i \cdot \int_0^{2\pi} [\cos (n + 1)t + i \sin (n + 1)t] dt.$$

But in the theory of integrals between real limits it is shown that

$$\int_0^{2\pi} \sin mtdt = 0$$

for every integral value of  $m$ , including zero, and that

$$\int_0^{2\pi} \cos mtdt = \begin{cases} 2\pi & \text{for } m = 0, \\ 0 & \text{for } m \neq 0. \end{cases}$$

We therefore obtain the following results :

VIII. If  $n$  is any integer (positive, negative, or zero), and if  $\Gamma$  is a curve inclosing the point  $\zeta$ , then

$$(10) \quad \int_{\Gamma} (z - \zeta)^n dz = 0 \text{ for } n \neq -1,$$

but

$$(11) \quad \int_{\Gamma} (z - \zeta)^{-1} dz = 2\pi i.$$

### § 36. Cauchy's Theorem

Again let  $f(z)$  be a function of a complex argument  $z$  regular in a domain  $B$ ; let  $\zeta$  be a point of this domain and  $\Gamma$  a curve bounding the domain. The function

$$\frac{f(z)}{z - \zeta}$$

is then regular in the domain  $B_1$ , which is the part remaining when the inside of a circle  $C$  with center  $\zeta$  and radius  $r$  is taken from  $B$ . By VII, § 35, therefore:

$$(1) \quad \int_{\Gamma} \frac{f(z)}{z - \zeta} dz = \int_C \frac{f(z)}{z - \zeta} dz.$$

The radius  $r$  of the circle  $C$  however is arbitrary: on account of the presupposed continuity of the function  $f(z)$ , we can take  $r$  so small that the inequality:

$$|f(z) - f(\zeta)| < \epsilon$$

is true for all points of the circle,  $\epsilon$  signifying a preassigned quantity arbitrarily small. If we now put:

$$\int_C \frac{f(z)}{z - \zeta} dz = f(\zeta) \int_C \frac{dz}{z - \zeta} + \int_C \frac{f(z) - f(\zeta)}{z - \zeta} dz,$$

then the first integral on the right-hand side, according to VIII, § 35, is

$$= 2\pi i f(\zeta);$$

and if in the second integral we put likewise :

$$(2) \quad \begin{aligned} z - \zeta &= r(\cos t + i \sin t), \\ dz &= ir(\cos t + i \sin t)dt, \\ \frac{dz}{z - \zeta} &= idt, \end{aligned}$$

we find ((3), § 35) that its absolute value is

$$\leq \epsilon \int_0^{2\pi} dt, \text{ that is, } \leq 2\pi\epsilon,$$

that is, it can be made smaller than any arbitrary, previously assigned quantity by taking  $r$  sufficiently small. But the value of the left side of equation (1), as also  $2\pi i f(\zeta)$ , is independent of  $r$ ; if the difference of these two quantities were different from zero, it could not be made smaller than any limit by making  $r$  smaller. It follows accordingly that

$$(3) \quad f(\zeta) = \frac{1}{2\pi i} \int_{\Gamma} \frac{f(z)}{z - \zeta} dz.$$

I. *By means of this formula stated by CAUCHY, the value which a regular function of a complex argument  $z$  has at any point  $\zeta$  of a domain  $B$ , is expressed by the value of the same function on the bounding curve  $\Gamma$  of the domain.*

The conclusion from this theorem is not that we can assign arbitrarily the values of such a function  $f(z)$  on the boundary: of course formula (3) would then always furnish a function  $f(\zeta)$  regular in the interior of the domain, but this function would not in general converge to the value preassigned at a point on the boundary as  $\zeta$  approaches this point.

If the curve  $\Gamma$  is a circle whose center is  $\zeta$ , and if we put  $f(z) = u + iv$  and  $f(\zeta) = u_0 + iv_0$ , introduce substitution (2) in

equation (3) and equate real and imaginary parts, it follows that:

$$u_0 = \frac{1}{2\pi} \int_0^{2\pi} u dt \quad \text{and} \quad v_0 = \frac{1}{2\pi} \int_0^{2\pi} v dt.$$

The first one of these equations expresses the fact that:

II. *The value of the real part of a regular function of a complex argument at the center of a circle, is equal to the mean of its values taken along the circumference.*

Thus it can neither be greater than all these values nor less than all of them. It therefore follows, provided the radius of the circle is taken sufficiently small, that:

III. *The real part of a function of a complex argument regular in a domain  $B$ , can never have a maximum nor a minimum at an inner point of this domain.*

The same theorems hold of course for  $v$ .

#### EXAMPLES

1. Evaluate the integral

$$\int \frac{dz}{z^2}$$

extended around any closed curve in the  $z$ -plane which does not pass through the point  $z = 0$ .

2. Compute  $\int_P z dz$  where  $P$  is a straight line from  $z = 0$  to  $z = a + bi$ .

HINT.—  $\int_P z dz = \int_P (x + iy)(dx + idy)$ ; express  $x$  and  $dy$  in terms of  $x$  and  $dx$  and take the limits on the integration from 0 to  $a$ .

3. Find the value of  $\int_C z dz$  where  $C$  is a circle whose center is at the origin and whose radius = 1.

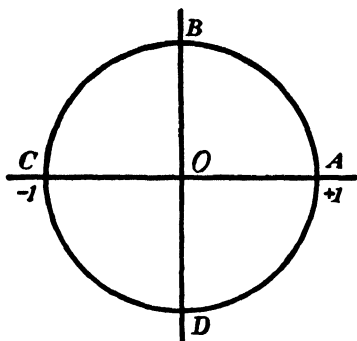

4. Show that  $\int_{\Gamma} \frac{dz}{z} = \pi i$  where  $\Gamma$  is  $ABC$  in the accompanying figure.

Show also that  $\int \frac{dz}{z} = -\pi i$  when taken along  $ADC$ .

Compute  $\int \frac{dz}{z}$  along  $ABCOA$ . What is its value if the curve does not inclose the point  $z=0$ ? Why?

5. Compute  $\int \frac{dz}{z}$  along  $ABCOA$  by polar coordinates.

Put  $z = r(\cos \phi + i \sin \phi)$ ,  $dz =$  etc.

6. Show by reducing all integrals in terms of the parameter  $t$ , that  $\int \frac{dz}{z}$  taken along the upper half of the ellipse  $x = a \cos t$ ,  $y = b \sin t$  is equal to  $\pi i$ .

7. Find the value of  $\int z^m dz$  along a unit square whose center is at the origin. For what values of  $m$  does the result hold?

8. Evaluate  $\int \frac{dz}{z - 2i}$  along a square having opposite vertices at  $0$  and  $2 + 2i$ .

9. Evaluate  $\int (z - a)^m dz$  along the circumference of a circle with center at  $a$  and with any radius. For what values of  $m$  is this integral equal to zero? What is its value when  $m = -1$ ?

10. What theorems are illustrated by examples 1-9?

11. Find the value of  $\int_C \frac{dz}{cz^2 - 1}$ ,  $\int_C \frac{dz}{cz^3 - 1}$ ,  $\int_C \frac{dz}{cz^4 - 1}$ , where  $C$  is any circle with its center at the origin and radius  $> 1$ . Discuss it when the radius is  $< 1$ .

HINT.—Put  $\frac{dz}{z^2 - 1} = \frac{\frac{dz}{z+1}}{z-1}$  and apply CAUCHY'S theorem.

### § 37. Development of a Regular Function in a Power Series

From his formula (3), § 36, CAUCHY deduced a general theorem concerning the development of a regular function in a power series. To prove the validity of this theorem, we begin with the series:

$$(1) \quad 1 + z + z^2 + \dots + z^n + \dots$$

already known in elementary analysis (A. A. § 54). The sum of the first  $n$  terms of this series is

$$s_n = \frac{1 - z^{n+1}}{1 - z};$$

if  $|z| < 1$ , we can make

$$(2) \quad \left| \frac{z^{n+1}}{1 - z} \right| < \epsilon,$$

for every positive quantity  $\epsilon$  however small provided that  $n$  be taken sufficiently large. Therefore

$$\lim s_n = \frac{1}{1 - z}$$

in accordance with the definition of convergence of an infinite series (IV, § 30 a), that is:

I. *Inside of the unit circle series (1) converges to  $(1 - z)^{-1}$ .*

But we can speak more precisely about the manner of convergence. If condition (2) is satisfied by a definite value of  $n$  for a definite positive quantity  $z = r$  and for a given  $\epsilon$ , then it

will be satisfied by the *same* value of  $n$  (and all larger values) for the same  $\epsilon$  and for every value of  $z$  whose absolute value is  $\leq r$ ; for,  $|z^n| \leq r^n$  and  $|1 - z| \geq 1 - r$  for all such values. We can then state the following theorem on the basis of the definition of uniform convergence (A. A. § 66):

II. *The series (1) converges uniformly in every circle about the origin with radius  $< 1$ .*

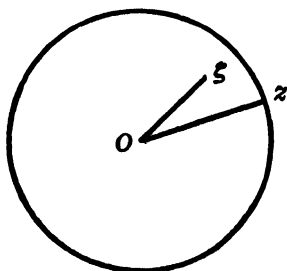

FIG. 18.

After proving this introductory theorem, we return now to equation (3), § 36. Let us suppose for the sake of simplicity that the origin lies on the inside of the domain defining the function  $f(z)$ ; we can then choose for the curve  $\Gamma$  a circle about the origin with a sufficiently small radius. Then

$$|\zeta| < |z|$$

for all points  $\zeta$  within this circle and for all points  $z$  upon it; accordingly, by I and II, the series

$$\frac{1}{z} + \frac{\zeta}{z^2} + \frac{\zeta^2}{z^3} + \dots + \frac{\zeta^n}{z^{n+1}} + \dots$$

converges uniformly to  $\frac{1}{z - \zeta}$

for all these values of  $\zeta$  and  $z$ . Moreover, the uniformity of the convergence holds if we multiply all the terms by  $f(z)$ . Therefore, by VIII, § 28, we may integrate the series thus formed, term by term, along the circumference of the circle. We obtain accordingly:

$$(4) \quad 2\pi i f(\zeta) = \int_{\Gamma} \frac{f(z) dz}{z} + \zeta \int_{\Gamma} \frac{f(z) dz}{z^2} + \zeta^2 \int_{\Gamma} \frac{f(z) dz}{z^3} + \dots \\ + \zeta^n \int_{\Gamma} \frac{f(z) dz}{z^{n+1}} + \dots$$

and along with this the theorem :

III. *If a function of a complex argument is regular in a circle about the origin, it can then be developed, for all points  $\zeta$  WITHIN this circle, in a convergent series of powers of  $\zeta$  with positive, integral, increasing exponents.*

The theorem, however, says nothing about the behavior of the series upon the circumference of the circle.

In evaluating the integrals in (4), the circle  $\Gamma$  can be replaced, according to VII, § 35, by any other curve about the origin provided that inside of this curve the function  $f(z)$  is regular.

### § 38. Properties of Complex Power Series

In connection with the results of the previous paragraph the converse question arises, whether a “*Power Series*” of the kind considered there always represents a regular function of the argument. Let such a series be represented by

$$(1) \quad \sum_{n=0}^{\infty} a_n z^n \equiv a_0 + a_1 z + a_2 z^2 + \cdots + a_n z^n + \cdots;$$

we inquire first about its convergence. It converges of course for  $z = 0$ ; if it converges for no other value, it could not be used as the definition of a function.

It is quite possible for a power series to converge “*permanently*”; that is, to converge for *all* finite values of  $z$  (examples of which will be found in § 40). It then represents a function regular over the whole plane; conversely, every function regular over the whole plane may be represented by such a permanently converging power series.

According to WEIERSTRASS, such a function is called a *transcendental integral function*.

If the series converges for any value  $z = c$  different from zero,

we can then prove the following theorems exactly as if the variables were restricted to real values (A. A. § 67):

I. *If a power series converges for any value  $z=c$  different from zero, it converges absolutely for every value of  $z$  whose absolute value is less than that of  $c$ , or geometrically: it converges absolutely everywhere within a circle having its center at the origin and its radius equal to  $|c|$ .*

II. *A power series which converges for values of  $z$  other than  $z=0$  but not for all values of  $z$ , always has a definite circle of convergence such that the series converges everywhere within it, diverges everywhere without it.*

But the theorem says nothing about the behavior of the series for the circle of convergence itself. There are examples for each of the three conceivable cases where the series converges for none, some, or all of the points on this circle.

The investigation of the uniform convergence of a power series must be carried out somewhat differently for complex values of the argument than for real values only. If  $c$  be a point within the circle of convergence, then all the terms of the series must be less than an assignable quantity  $g$ ; that is,

$$|a_n c^n| < g$$

for  $m = 0, 1, 2, \dots$ . If therefore  $z$  is any quantity whose absolute value is smaller than that of  $c$  and if we put

$$|z| = \lambda |c|,$$

we obtain:

$$\begin{aligned} |a_n z^n| + |a_{n+1} z^{n+1}| + \dots + |a_{n+p} z^{n+p}| &< g \lambda^n (1 + \lambda + \dots + \lambda^p) \\ &< \frac{g \lambda^n}{1 - \lambda}. \end{aligned}$$

If the fraction on the right-hand side is less than a given quantity  $\epsilon$  for definite values of  $\lambda (< 1)$  and  $n$ , then it is also smaller

than  $\epsilon$  for the same  $n$  and all smaller values of  $\lambda$ . But from this it follows that :

III. *Every power series converges uniformly in any domain which lies entirely within its circle of convergence.\**

Accordingly (cf. A. A. § 66), the sum of such a series is a *continuous* function of  $x$  and  $y$  everywhere within the true circle of convergence; but on the basis of the theorems of § 28, we can draw other conclusions concerning this series. For this purpose we shall need the theorem (A. A. 5, § 60; 5, § 70) that the series

$$1 + 2\lambda + 3\lambda^2 + \dots + (n+1)\lambda^n + \dots$$

converges for  $\lambda < 1$  [and to  $(1-\lambda)^{-2}$ ]. With the aid of this theorem it follows, by conclusions exactly parallel to those heretofore drawn, that :

IV. *The series*

$$(2) \quad f'(z) = a_1 + 2a_2z + 3a_3z^2 + \dots + (n+1)a_{n+1}z^n + \dots$$

*also converges uniformly and represents accordingly a continuous function of  $x$  and  $y$  in every domain which lies entirely within the true circle of convergence of series (1).*

But series (2) is the series formed by taking the derivative of series (1) term by term; from X, § 28, it follows then that :

V. *Every power series of the form (1) has a definite derivative with respect to  $z$  everywhere within its circle of convergence and accordingly represents there a regular function of a complex argument  $z$  in the sense of § 33.*

\* By making use also of Theorem IV, § 67, A. A., it can be shown that a power series converges uniformly in every triangle which, with the exception of one vertex, lies entirely within the circle of convergence, provided only that it converges at this vertex. But this theorem will not be needed.

¶ This theorem is the converse of CAUCHY'S Theorem III, § 37.

Since we represented the derivative of the above function by a power series, we can apply the same methods to it and in this way prove the existence of a second derivative, etc. We therefore state the following general theorem :

VI. *Every power series has an unlimited number of successive derivatives continuous inside of its circle of convergence.*

This result, in connection with CAUCHY'S theorem, enables us to state the following fundamental theorem :

VII. *Every function of a complex argument, which is regular in a given domain, has an unlimited number of successive derivatives continuous within this domain; and these derivatives are regular functions.*

If instead of the expression "regular function of a complex argument," we use only its meaning in terms of real functions, this theorem is stated as follows :

VIIa. *If  $u$  and  $v$  are two real functions of  $x, y$  which are continuous in a given domain and which have continuous first derivatives satisfying the differential equations*

$$\frac{\partial u}{\partial x} = \frac{\partial v}{\partial y}, \quad \frac{\partial v}{\partial x} = -\frac{\partial u}{\partial y},$$

*it follows at once from this that they have an unlimited number of successive derivatives continuous within this domain.*

With the aid of these results the theorems deduced in § 34 may be supplemented at important places. If  $w = u + iv$  is a regular function of  $z = x + iy$ , then the functional determinant

$$\frac{\partial u}{\partial x} \cdot \frac{\partial v}{\partial y} - \frac{\partial v}{\partial x} \cdot \frac{\partial u}{\partial y} = \left(\frac{\partial u}{\partial x}\right)^2 + \left(\frac{\partial v}{\partial x}\right)^2 = \left|\frac{dw}{dz}\right|^2,$$

and hence is not negative. Since we have proved (VII) the continuity of the derivatives which appear, we can apply Theorem IV of § 27 and conclude that:

VIII. *If  $w = f(z)$  is a function which is regular and single-valued in a domain  $B$  and which has a derivative different from zero everywhere in this domain, then the values which  $w$  takes on in  $B$  cover once without gaps a definite region  $C$  of the  $w$ -plane.*

Since the value of the limit  $\frac{dz}{dw}$  is the reciprocal of the value of the limit  $\frac{dw}{dz}$ , it follows further that:

IX.  *$z$  is also a function of  $w$  regular within the region  $C$ .*

Besides:

X. *If the function  $w = f(z)$  satisfies the provisions of Theorem VIII and if  $W = \phi(w)$  is a function of  $w$  regular in  $C$ , then  $W = \phi(f(z))$  is also a function of  $z$  regular within  $B$ .*

For, from the existence of the limits  $\frac{dw}{dz}$  and  $\frac{dW}{dw}$  we infer the existence of the limit  $\frac{dW}{dz}$  as with functions of real variables.

Finally, the following theorems are proved just as if the variables were restricted to real values (A. A. I, II, § 77):

XI. *If a given power series converges for other values in addition to  $z = 0$ , then a limit  $\rho$  can be so chosen for the absolute value of  $z$  that for all  $|z| < \rho$ , the first term of the series whose coefficient is not zero is greater in absolute value than the sum of all the remaining terms.*

XII. *For every function  $f(z)$  regular in the neighborhood of the point  $z = 0$ , a circle can be drawn about  $z = 0$  with a radius so small that no zero of  $f(z)$  lies in it, except possibly  $z = 0$  itself.*

With the aid of Theorem VII we may prove also the following converse of Theorem IV, § 35 :

XIII. *If the function  $f(z)$  is continuous inside of a simply connected domain  $B$ , and if*

$$\int_{\Gamma} f(z) dz = 0$$

*for every closed line  $\Gamma$  which lies entirely inside of this domain, then  $f(z)$  is regular inside of this domain.*

That is to say (cf. the proof of V, § 35),

$$\int_{z_0}^z f(z) dz$$

is then independent of the path (considering only paths inside of  $B$ ), and therefore, by keeping  $z_0$  fixed is by definition a single-valued function of  $z$ . This function has a definite derivative, viz.  $f(z)$  at every point of  $B$  (cf. the proof of VI,\* § 35). It is accordingly regular ; and therefore according to VII,  $f(z)$  is also regular.

### § 39. Taylor's, Maclaurin's Development in a Power Series for Complex Variables

If we put  $z=0$  in the development of the derivatives of  $f(z)$  in series obtained successively in the previous paragraphs, the following series of equations result :

$$(1) \quad \begin{aligned} f(0) &= a_0, \\ f'(0) &= a_1, \\ f''(0) &= 2 a_2, \\ &\cdot \quad \cdot \quad \cdot \\ f^n(0) &= n! a_n. \end{aligned}$$

\* We notice that that proof makes use only of the continuity of  $f(z)$  and the fact that the integral is independent of the path, and not of the existence of  $f'(z)$ .

These show that the coefficients of the proposed development of  $f(z)$  in a series are expressible (cf. A. A. § 68; § 81) uniquely by the values of the derivatives of  $f(z)$  for  $z = 0$ . We call attention to only one feature of this result, viz., that these coefficients are definite whenever the values of  $f(z)$  satisfy any indefinitely small arc of a curve through the origin [or when the values of  $f(z)$  determine a set of points which has the origin for a limit point (III, § 23)]; for, this is at once sufficient to determine the values of the derivatives. This theorem is expressible in a different form; viz.:—

I. *When two series in powers of  $z$  with positive integral exponents have the same value along an indefinitely small arc of a curve through the origin, then the two series must coincide term for term, or;*

II. *A regular function of  $z$  can be developed in such a power series in only one way.*

Therefore when it is possible to develop a function of a complex argument in such a power series, we may write the series with undetermined coefficients and then determine these coefficients by any suitable relation which we know the function satisfies. We call this procedure *the method of undetermined coefficients*. (Cf. A. A. § 78.) It is of considerable service in many cases; however, in its application, we must always keep in mind that in itself it never contains a proof of the possibility of the development of a function in a series of a specified form. It is supposed at the outset that such a development is possible.

Further, if the values of the coefficients so determined are introduced in series (1) of the previous paragraph, we obtain the

III. MACLAURIN'S series :

$$(2) \quad f(z) = f(0) + z f'(0) + \frac{z^2}{1 \cdot 2} f''(0) + \dots + \frac{z^n}{n!} f^n(0) + \dots$$

Moreover, we obtain from 4, § 37, on the basis of Theorem II, the following

IV. *Expressions for the value of the function and its derivatives at the origin in the form of definite integrals:*

$$(3) \quad \left\{ \begin{array}{l} f(0) = \frac{1}{2\pi i} \int \frac{f(z) dz}{z}, \\ f'(0) = \frac{1}{2\pi i} \int \frac{f(z) dz}{z^2}, \\ \vdots \\ f^{(n)}(0) = \frac{n!}{2\pi i} \int \frac{f(z) dz}{z^{n+1}}. \\ \vdots \end{array} \right.$$

All these integrals are to be taken along a circle which belongs entirely to the interior of the domain in which the function is regular, and which surrounds the origin once; according to VII, § 35, they can be taken along any other curve of the domain inclosing the origin instead of this circle.

From Theorem I and the representation by integrals in (3) we may obtain inequalities for the coefficients of a power series which we shall need later, and on this account we deduce them at this point. If  $M$  is the upper limit of the absolute values which a function takes on, on a circle of radius  $r$  and on which the series is convergent, it then follows that:

$$|a_n| \leq \frac{1}{2\pi} \int \frac{|f(z)|}{|z^n|} \left| \frac{dz}{z} \right| < \frac{Mr^{n-1}}{2\pi} \int \left| \frac{dz}{z} \right|.$$

But  $\left| \frac{dz}{z} \right| = d\phi$ , if we put  $z = r(\cos \phi + i \sin \phi)$  (cf. 8, 9, § 35);

and therefore:

$$(4) \quad |a_n| < Mr^{n-1}.$$

We thus obtain the following theorem :

V. *If  $r$  and  $M$  have the meaning given them above for a power series, then the coefficients of this power series satisfy inequality (4); in other words, their absolute values are smaller than the corresponding coefficients of the development of\**

$$\frac{M}{1 - \frac{z}{r}}$$

in a series.

This may also be written

$$(5) \quad f(z) \ll \frac{M}{1 - \frac{z}{r}} \quad (\text{argument } z).$$

The results of the last paragraphs permit a simple generalization to the case for which another point of the plane is used in place of the origin. If, therefore,  $f(z)$  is a function which is regular in the neighborhood of  $z=a$ , it is transformed by the substitution

$$(6) \quad z - a = \zeta$$

into a function  $\phi(\zeta)$  of  $\zeta$ , which is regular in the neighborhood of the origin, and hence by IV can be developed in the MACLAURIN'S series :

$$\phi(\zeta) = \phi(0) + \zeta \phi'(0) + \frac{\zeta^2}{1 \cdot 2} \phi''(0) + \dots$$

If we again introduce  $z$  and  $f$  in place of  $\zeta$  and  $\phi$ , we obtain

VI. *The TAYLOR series :*

$$(7) \quad f(z) = f(a) + (z-a)f'(a) + \frac{(z-a)^2}{1 \cdot 2} f''(a) + \dots \\ + \frac{(z-a)^n}{n!} f^{(n)}(a) + \dots$$

\* The number  $M$  is definitely defined by this equation just as it is when restricted to real numbers (A. A. I, § 79); we notice also that the  $M$  thus defined need not be the smallest of the numbers  $M$  for which a system of inequalities of the form (4) exists.

It converges inside of a circle drawn about the point  $z = a$  as a center, in which the function  $f(z)$  is regular.

In place of the formulas (3) we have in this case :

$$\begin{aligned}
 f(a) &= \frac{1}{2\pi i} \int \frac{f(z) dz}{(z-a)}, \\
 f'(a) &= \frac{1}{2\pi i} \int \frac{f(z) dz}{(z-a)^2}, \\
 f''(a) &= \frac{2!}{2\pi i} \int \frac{f(z) dz}{(z-a)^3}, \\
 f^{(n)}(a) &= \frac{n!}{2\pi i} \int \frac{f(z) dz}{(z-a)^{n+1}}, \\
 &\vdots \\
 &\vdots
 \end{aligned}
 \tag{8}$$

These integrals are to be taken along a curve which makes a simple circuit about the point  $z = a$  and which belongs entirely to the domain in which the function is regular. The first of these formulas is identical with (3), § 36; the remaining ones can be obtained by replacing the function  $f(z)$  in that formula by its derivatives and then repeating partial integration.

By means of these results Theorem I may be generalized further as follows :

VII. *When two functions of  $z$  regular inside of a domain  $B$  coincide along an arc of a curve however small belonging to this domain, they coincide everywhere in the domain.*

For, if  $a$  be a point on an arc of this curve, we can, for the circle of convergence  $K$ , prove the coincidence of the developments of both functions arranged according to powers of  $z - a$ . If there are points of  $B$  outside of  $K$ , we can then find a point  $b$  in  $K$  which is farther distant from all points of the bound-

ary of  $B$  than from the nearest point of  $K$ . Therefore, the development of the two functions in powers of  $z - b$  converges also in points outside of  $K$ ; and we obtain accordingly their coincidence for these points. In this way the coincidence of the two developments can be proven for all inner points; *for the boundary points, it follows from the continuity*. Moreover, corresponding conclusions can also be drawn when the coincidence of the two functions is known only for the points of a set which has a limit point *on the inside* of the domain in which the functions are regular.

We return at this point to Theorem XII of the previous paragraph, which is at once applicable to series in powers of  $z - a$ . But in consideration of VI it can be expressed as follows:

VIII. *If a point  $z_0$  be given inside the domain in which a regular function of  $z$ ,  $f(z)$ , is defined, then every zero of this function different from  $z_0$  is distant from  $z_0$  by more than an assignable quantity.*

Therefore, the zeros of a regular function can have a limit point nowhere within the domain in which it is defined (but at most on its boundary). Accordingly, on account of XVI, § 25, it follows:

IX. *In every domain which lies entirely within the domain in which a regular function is defined, there are only a finite number of zeros of this function.*

#### EXAMPLES

1. The series  $1 + az + a^2z^2 + \dots$ , ( $a > 0$ ), has a circle of convergence whose radius is equal to  $\frac{1}{a}$ . How does the series behave inside of, upon, and outside of this circle of convergence?

NOTE.— Let  $z = r_1$  be any point on the positive real axis. If the power series converges when  $z = r_1$ , it converges absolutely for all points inside the circle  $|z| = r_1$  and, in particular, for all real values of  $z$  less than  $r_1$ .

2. What is the radius of convergence for the series

$$\frac{z}{1^2} + \frac{z^2}{2^2} + \frac{z^3}{3^2} + \dots$$

and how does it behave at all points on its circle of convergence?

3. The series  $z - \frac{z^2}{2} + \frac{z^3}{3} - \dots$  has its radius of convergence equal to unity. It diverges for  $z = -1$ , but is convergent (though not absolutely) for all other points on the circle of convergence, since its real and imaginary parts are  $\cos \theta - \frac{\cos 2\theta}{2} + \dots$  and  $\sin \theta - \frac{\sin 2\theta}{2} + \dots$ . Give the proof.

4. If  $|z|$  is less than the radius of convergence of either of the series  $\sum a_n z^n$ ,  $\sum b_n z^n$ , then the product of the two series is  $\sum c_n z^n$  when  $c_n = a_0 b_n + a_1 b_{n-1} + a_2 b_{n-2} + \dots + a_n b_0$ . Prove.

5. What is the condition for the convergence of the product of two series? (That they be absolutely convergent, since this permits of a rearrangement of the terms in any order. However, two series *not* absolutely convergent may be multiplied *provided only that the product is convergent*. This result is known as ABEL'S theorem on the multiplication of series.)

6. If the radius of convergence of  $\sum a_n z^n$  is  $r$  and  $f(z)$  is the sum of the series when  $|z| < r$  and  $|z|$  is less than either  $r$  or unity, then  $\frac{f(z)}{1-z} = \sum s_n z^n$  where  $s_n = a_0 + a_1 + a_2 + \dots + a_n$ .

7. Show by squaring the series for  $\frac{1}{1-z}$  that

$$\frac{1}{(1-z)^2} = 1 + 2z + 3z^2 + \dots \text{ if } |z| < 1.$$

8. Prove in the same way that  $\frac{1}{(1-z)^3} = 1 + 3z + 6z^2 + \dots$ , the general term being  $\frac{1}{2}(n+1)(n+2) \cdot z^n$ .

9. If  $f(z) = 1 + z + \frac{z^2}{1 \cdot 2} + \dots$  show that  $f(z)f(y) = f(z + y)$ .

[The series for  $f(z)$  is absolutely convergent for all values of  $z$ : and if  $u_n = \frac{z^n}{n!}$  and  $v_n = \frac{y^n}{n!}$ , it follows that  $w_n = \frac{(z + y)^n}{n!}$ .]

10. Expand the function  $\log(1 + e^z)$  to five terms by TAYLOR'S theorem, and determine the radius of convergence of the series.

11. When and where did CAUCHY first publish his theorem about the extension of TAYLOR'S theorem to functions of a complex variable?

12. Given  $\int \frac{z^3 dz}{(z - a)(z - b)}$ : determine the domain such that the value of this integral taken along its boundary shall be equal to zero.

HINT.  $-\int \frac{z^3 \cdot dz}{(z - a)(z - b)} = \int \frac{z^3 \cdot dz}{z - a} = f(b) \cdot 2\pi i = \frac{b^3}{b - a} \cdot 2\pi i$  for a circle center at  $b$ , and a similar expression for a circle center at  $a$ . Their sum  $= \frac{a^3 - b^3}{a - b} \cdot 2\pi i$  and this  $= 0$  for certain solutions,  $a = b$  excluded, and therefore the configuration may be obtained accordingly.

13. Find the value of  $\int \frac{dz}{z^2 - 1}$  taken along a circle whose center is  $z = 1$  and radius  $< 2$ . Why not take the radius of the circle  $> 2$ ?

14. Evaluate  $\int \frac{z^3 \cdot dz}{z^2 - 1}$  for a circle having its center at 1 and radius  $< 1$ : also for a circle having its center at 1 and radius  $> 1$  and  $< 2$ : also its value for a circle having its center at 1 and radius  $> 2$ .

15. Evaluate  $\int \frac{\cos \pi z dz}{(z-1)^5}$  taken along a circle whose center is the origin and radius  $> 1$ . *Ans.*  $-\frac{\pi^5 \cdot i}{12}$ .

HINT. — Apply the formula  $f^n(a) = \frac{n!}{2\pi i} \int \frac{f(z) dz}{(z-a)^{n+1}}$  along any contour including the point  $a$ .

16. Give examples of power series which converge on some, none, and all points of their circles of convergence.

17. Determine the circle of convergence for the series

$F(\alpha, \beta, \gamma, z) =$

$$1 + \sum_{n=1}^{\infty} \frac{\alpha(\alpha+1)\cdots(\alpha+n-1)}{1 \cdot 2 \cdots n} \cdot \frac{\beta(\beta+1)\cdots(\beta+n-1)}{\gamma(\gamma+1)\cdots(\gamma+n-1)} \cdot z^n$$

where  $\alpha, \beta, \gamma$  are not negative integers and  $\gamma \neq 0$ . This series is known as GAUSS'S series and belongs to the class of hypergeometric series. See GAUSS, *Ges. Werke*, Vol. III, p. 125, RIEMANN, *Werke*, 1876, p. 79, PIERPONT, *Functions of a complex Variable*, p. 54.

HINT. — By the ratio test, the series converges absolutely where  $|z| < 1$  and diverges for  $|z| > 1$ . If  $|z| = 1$ , it converges for  $\alpha + \beta - \gamma < 0$ , diverges for  $\alpha + \beta - \gamma \geq 0$ .

The series is one of very great generality and includes as particular examples many well-known series, as

$$\log(1+z) = z \cdot F(1, 1, 2, -z), \quad (1+z)^n = F(-n, \beta, \beta, -z).$$

18. If the absolute values of the coefficients of the integral power series

$$\sum_{n=0}^{\infty} a_n z^n$$

are finite, the circle of convergence has at least the radius 1; when is it exactly 1?

19. If in the convergent power series

$$f(z) = a_0 + a_1z + \dots$$

the constant term  $a_0$  is not zero, a number  $k$  can be found such that  $f(z)$  vanishes for no value of  $z$  whose absolute value is less than  $k$ .

20. Develop the following functions of  $z$  in an integral power series in  $z$ :

$$(1) \quad \frac{1 - z \cos \alpha}{1 - 2z \cos \alpha + z^2}; \quad (2) \quad \frac{\sin \alpha}{1 - 2z \cos \alpha + z^2}.$$

The circle of convergence of these power series has the radius unity since the denominator of both functions vanishes in the points  $z = \cos \alpha \pm i \sin \alpha$ .

21. The FRESNEL integrals are

$$C(z) = \frac{1}{\sqrt{2\pi}} \int_0^z \frac{\cos z}{\sqrt{z}} dz; \quad S(z) = \frac{1}{\sqrt{2\pi}} \int_0^z \frac{\sin z}{\sqrt{z}} dz.$$

Obtain power series in  $z$  for  $C(z)$  and  $S(z)$ . Calculate

$$C(1) = .7217, \quad C(3) = .5610, \quad S(1) = .0924.$$

22. Show that  $\int_0^{\frac{\pi}{2}} \sin^{\frac{5}{2}}(z) dz = .9309+$ .

$$\begin{aligned} 23. \quad K &= \int_0^{\frac{\pi}{2}} \frac{1}{\sqrt{1 - k^2 \sin^2 \phi}} \cdot d\phi \\ &= \frac{\pi}{2} \left[ 1 + \left(\frac{1}{2}\right)^2 k^2 + \left(\frac{1 \cdot 3}{2 \cdot 4}\right)^2 k^4 + \left(\frac{1 \cdot 3 \cdot 5}{2 \cdot 4 \cdot 6}\right)^2 k^6 + \dots \right]. \end{aligned}$$

Obtain this result. The time of swing of a simple pendulum of length  $l$  through an angle  $\alpha$  is  $4\sqrt{\frac{l}{g}} \cdot K$  where  $k = \sin\left(\frac{\alpha}{2}\right)$ . Compute this time when  $\alpha = 60^\circ$ .

### § 40. The Exponential Function and the Trigonometric Functions, Sine and Cosine

In the first chapter we inquired about combinations of complex numbers which follow the same fundamental laws as the combinations of real numbers considered in elementary arithmetic and to which we accordingly applied the same names, designated them by the same symbols, and regarded them as generalizations of elementary algebraic operations. In the same way we inquire now about a generalization of the *transcendental* functions of real argument treated in elementary analysis; for the simplest of these functions, the methods already deduced are sufficient to answer this question.

What is, for example,  $e^z$  (or  $\sin z$ ) for complex values of  $z$ ? In itself it has no logical meaning whatever. To give it such a meaning, we inquire whether there exists a function of a complex argument  $z$  which has the same properties as the function of a real variable  $x$ , designated by  $e^x$  in the elementary theory, and which reduces to this function when a real value  $x$  is given to  $z$ . This cannot at once be answered in the affirmative; for, properties which are consistent with each other for real values of  $z$  may be contradictory for complex values (cf. § 30). We see that a certain freedom is unavoidable here: we are compelled to retain some of the properties of a function of real argument in order to use them as the basis for the definition of its generalization for complex values; the object of the investigation then is to find out which of the remaining properties of the given function of real argument are valid for such generalization.

Whatever specially concerns the functions  $e^z$ ,  $\sin z$ ,  $\cos z$ , they are represented in elementary analysis (A. A. II, § 71; 6, § 75) by the power series:

$$(1) \quad e^z = 1 + z + \frac{z^2}{1 \cdot 2} + \dots + \frac{z^n}{n!} + \dots$$

$$(2) \quad \sin z = z - \frac{z^3}{1 \cdot 2 \cdot 3} + - + \dots + (-1)^n \frac{z^{2n+1}}{(2n+1)!} + \dots$$

$$(3) \quad \cos z = 1 - \frac{z^2}{1 \cdot 2} + - + \dots + (-1)^n \frac{z^{2n}}{(2n)!} + \dots$$

It is easily shown that these series converge for all real finite values of  $z$ . According to I, § 38, they then converge for all finite complex values of  $z$  and represent (§ 38) transcendental integral functions of  $z$ . Accordingly:

I. *There are three transcendental integral functions of a complex argument  $z$  represented by the series (1)–(3), whose values for real values of the argument coincide with the values of the functions  $e^z$  or exponential  $z$ ,  $\sin z$ ,  $\cos z$ , defined in elementary analysis; we retain here the names and the symbols of these functions of a real argument.*

We find directly from the definition by means of the series (1)–(3) that:

II. *The following relations due to EULER hold between these functions:*

$$(4) \quad e^{iz} = \cos z + i \sin z,$$

$$(5) \quad e^{-iz} = \cos z - i \sin z$$

with their solutions:

$$(6) \quad \cos z = \frac{1}{2}(e^{iz} + e^{-iz}),$$

$$(7) \quad \sin z = \frac{1}{2i}(e^{iz} - e^{-iz}),$$

or what is the same thing:

$$(8) \quad \cos iz = \frac{1}{2}(e^z + e^{-z}),$$

$$(9) \quad \sin iz = \frac{i}{2}(e^z - e^{-z}).$$

III. *We shall make particular use of equation (4) in order to represent a complex number in terms of its absolute value and amplitude (II, § 4) in the following shorter form :*

$$(10) \quad z = re^{i\phi}.$$

A fundamental property of the exponential function of real argument is expressed in the

IV. *Addition theorem :*

$$(11) \quad e^{z_1+z_2} = e^{z_1} \cdot e^{z_2};$$

we may verify its existence for complex arguments by multiplying together the series on the right (A. A. § 60) with the aid of elementary properties of the binomial coefficients. By repeated application of this theorem and putting all arguments equal to each other, it follows that the equation :

$$(12) \quad e^{nz} = (e^z)^n$$

is true for integers  $n$ , understanding the exponents on the right-hand side to be positive integers as in § 18. If  $z_2 = -z_1$ , it follows from (11) that :

$$(13) \quad e^{-z} = \frac{1}{e^z}.$$

If, further, we express the sine and the cosine of a sum in terms of the exponential functions by (6) and (7), apply the addition theorem (11) to them, and then introduce the trigonometric functions again by means of (4) and (5), we obtain :

V. *The addition theorems for the trigonometric functions, sine and cosine :*

$$(14) \quad \sin(z_1 + z_2) = \sin z_1 \cdot \cos z_2 + \cos z_1 \cdot \sin z_2,$$

$$(15) \quad \cos(z_1 + z_2) = \cos z_1 \cdot \cos z_2 - \sin z_1 \cdot \sin z_2.$$

From the second of these equations it follows for  $z_2 = -z_1$ , that :

$$(16) \quad \cos^2 z + \sin^2 z = 1.$$

By differentiation of the series (1)–(3) term by term, which is permissible according to IV, V, § 38, we obtain :

VI. *The differential equations :*

$$(17) \quad \frac{de^z}{dz} = e^z, \quad \frac{d \sin z}{dz} = \cos z, \quad \frac{d \cos z}{dz} = -\sin z.$$

We have thus established a generalization of the fundamental properties of the real functions  $e^z$ ,  $\sin z$ ,  $\cos z$  to the functions of a complex argument which are similarly designated.

### EXAMPLES

1. Solve the equation  $\cos z = a$ , where  $a$  is real.

Put  $z = x + iy$  and equate real and imaginary parts. Thus  $\cos x \cdot \cosh y = a$ ;  $\sin x \cdot \sinh y = 0$  (where  $\cos(iy) = \cosh y$  and  $\sin(iy) = i \sinh y$  by definition, § 40, II). Therefore either  $y = 0$  or  $x$  is a multiple of  $\pi$ . If, *first*,  $y = 0$  then  $\cos x = a$ , which is impossible unless  $-1 \leq a \leq 1$ . This leads to the solution :

$$z = 2k\pi \pm \cos^{-1}a$$

where  $\cos^{-1} a$  lies between zero and  $\pi$ .

If, *second*,  $x = m\pi$  then  $\cosh y = (-1)^m a$ , so that either  $a \geq 1$  and  $m$  is even, or  $a \leq -1$  and  $m$  is odd. If  $a = \pm 1$  then  $y = 0$  and this is the first case. If  $|a| > 1$ , then  $\cos iy = |a|$  and we obtain the solutions

$$z = 2k\pi \pm i \operatorname{Log} \{a + \sqrt{a^2 - 1}\}, \quad (a > 1),$$

$$z = (2k+1)\pi \pm i \operatorname{Log} \{-a + \sqrt{a^2 - 1}\}, \quad (a < -1).$$

2. The solution of  $\cos z = -5/3$  is  $z = (2k+1)\pi \pm i \operatorname{Log} 3$ .

3. Solve  $\sin z = a$  where  $a$  is real.

4. Solve the equation  $\tan z = a$  where  $a$  is real. (The roots are all real.)

5. Solve the equation  $\cos z = a + ib$  ( $b \neq 0$ ). Let us take  $b > 0$  since the results for  $b < 0$  may be obtained by merely changing the sign of  $b$ . For this case, therefore,

$$(1) \quad \cos x \cdot \cosh y = a; \quad \sin x \cdot \sinh y = -b,$$

and

$$(a/\cosh y)^2 + (b/\sinh y)^2 = 1 \text{ (using the notation of Ex. 1).}$$

The solution of this last equation gives

$$\cosh^2 y = (A_1 \pm A_2)^2,$$

where  $A_1 = \frac{1}{2}\sqrt{(a+1)^2 + b^2}$ ,  $A_2 = \frac{1}{2}\sqrt{(a-1)^2 + b^2}$ .

Suppose now  $a > 0$ . Then  $A_1 > A_2 > 0$  and  $\cosh y = A_1 \pm A_2$ .  
Moreover  $\cos x = a/\cosh y = A_1 \mp A_2$ ,

and since  $\cosh y > \cos x$  we must take

$$\cosh y = A_1 + A_2 \text{ and } \cos x = A_1 - A_2.$$

The general solutions of these equations are

$$(2) \quad x = 2k\pi \pm \cos^{-1} M, \quad y = \pm \text{Log} \{L + \sqrt{L^2 - 1}\}$$

where  $L = A_1 + A_2$ ,  $M = A_1 - A_2$  and  $\cos^{-1} M$  lies between zero and  $\frac{\pi}{2}$ .

The values of  $x$  and  $y$  thus found include the solutions of the equations

$$(3) \quad \cos x \cdot \cosh y = a, \quad \sin x \cdot \sinh y = b$$

as well as those of equations (1), since we have used only the second of equations (3) after squaring it. To distinguish the two sets of solutions we observe that the sign of  $\sin x$  is the same as the ambiguous sign in the first of equations (2), and the sign of  $\sinh y$  is the same as the ambiguous sign in the second. Since  $b > 0$  these two signs must be different. Hence the general solution required is

$$z = 2k \pm [\cos^{-1} M - i \text{Log} \{L + \sqrt{L^2 - 1}\}].$$

6. Study the cases of the last problem where  $a < 0$  and  $a = 0$ .

7. Show as in Ex. 5 that, if  $a$  and  $b$  are positive, the general solution of  $\sin z = a + ib$  is

$$z = k\pi + (-1)^k [\sin^{-1} M + i \operatorname{Log} \{L + \sqrt{L^2 - 1}\}],$$

where  $\sin^{-1} M$  lies between  $0$  and  $\frac{\pi}{2}$ .

8. Show that the general solution of  $\tan z = a + ib$ ,  $b \neq 0$ , is

$$z = k\pi + \frac{\theta}{2} + \frac{i}{4} \operatorname{Log} \left\{ \frac{a^2 + (1+b)^2}{a^2 + (1-b)^2} \right\}$$

where  $\theta$  is the numerically least angle such that

$$\cos \theta : \sin \theta : 1 :: 1 - a^2 - b^2 : 2a : \sqrt{(1 - a^2 - b^2)^2 + 4a^2}.$$

9. Calculate  $\cos i$ ,  $\sin(1+i)$ ,  $\sin(\pi - 1 - i)$  to two places of decimals by means of the power series for  $\cos z$  and  $\sin z$ .

10. Prove that  $|\cos z| \leq \cosh |z|$  and  $|\sin z| \leq \sinh |z|$ .

11. Show that  $|\cos z| < 2$  and  $|\sin z| < 6/5 |z|$  if  $|z| < 1$ .

12. Since  $\sin 2z = 2 \sin z \cdot \cos z$  we have

$$(2z) - \frac{(2z)^3}{3!} + \frac{(2z)^5}{5!} - \dots = 2 \left( z - \frac{z^3}{3!} + \frac{z^5}{5!} - \dots \right) \left( 1 - \frac{z^2}{2!} + \dots \right).$$

Prove by multiplying the two series on the right-hand side and equating coefficients that

$$\binom{2n+1}{1} + \binom{2n+1}{3} + \dots + \binom{2n+1}{2n+1} = 2^{2n}$$

for which the notation  $\binom{n}{r}$  means  $\frac{n \cdot n-1 \cdot \dots \cdot n-r+1}{1 \cdot 2 \cdot \dots \cdot r}$ . Verify the result by the binomial theorem.

### § 41. Periodicity of the Trigonometric and the Exponential Functions

The sine and the cosine of a real argument are *periodic\** functions with the period  $2\pi$ ; that is, the following equations:

$$(1) \quad \sin(z + 2\pi) = \sin z, \quad \cos(z + 2\pi) = \cos z,$$

are identically true for all real values of  $z$  (A. A. § 76). We can at once conclude from this and from Theorem I, § 39, that these equations must also hold for all complex values of  $z$ .

(Periodic functions are a special kind of automorphic functions (IV, § 17)).

It then follows from the relations due to EULER that:

$$(2) \quad e^{z+2\pi i} = e^z,$$

that is,

I. *The exponential function is a periodic function with the period  $2\pi i$ .*

It is further shown in the theory of trigonometric functions of real arguments (A. A. VI, § 76) that  $2\pi$  is a *primitive* period of the cosine and of the sine; that is, that no aliquot part of  $2\pi$  is a period of these functions. It thus follows indirectly from equation 8, § 40, that:

II.  *$2\pi i$  is a primitive period of the exponential function.*

We shall now investigate whether the exponential function has other primitive periods besides  $2\pi i$  and  $-2\pi i$ . For this purpose we deduce the following theorems from its definition and from equations (13) and (17) of § 40 (cf. also A. A. § 52):

III. *The exponential function increases continuously from 0 to  $+\infty$ , while its argument continuously increasing takes on all real values from  $-\infty$  to  $+\infty$ .*

\* Cf. Ex. 4, following § 18, and Ex. 31 at the end of chap. IV.—S. E. R.

IV. *It takes on therefore each real positive value for one and for only one real value of its argument.*

Assume now that  $a$  is a period of the exponential function and that  $z_1$  and  $z_2$  are two values differing by  $a$  so that

$$(3) \quad z_2 - z_1 = a;$$

then

$$(4) \quad e^{z_1} = e^{z_2}.$$

By means of (4) and (11) of § 40 we can separate the real and imaginary parts of the exponential function; thus

$$(5) \quad e^{x+iy} = e^x \cos y + i e^x \sin y.$$

If we then put  $z_1 = x_1 + iy_1$ ,  $z_2 = x_2 + iy_2$ ,

it follows from (4) that

$$(6) \quad e^{x_1} \cos y_1 = e^{x_2} \cos y_2, \quad e^{x_1} \sin y_1 = e^{x_2} \sin y_2,$$

and from both equations on account of (16), § 40:

$$e^{2x_1} = e^{2x_2}.$$

But from this it follows according to IV, that

$$x_1 = x_2,$$

and from the properties of trigonometric functions of real arguments (A. A. p. 167, line 7):

$$y_2 = y_1 + 2k\pi.$$

We thus obtain the theorem:

V. *Every period of the exponential function is an integral multiple of  $2\pi i$  and every period of the sine or the cosine is an integral multiple of  $2\pi$ .*

We add also the following definition :

VI. *A periodic function, all of whose periods are integral multiples of a primitive period, is called a singly periodic function.*

We can therefore state the theorem :

VII. *The exponential function, the sine, and the cosine are singly periodic functions.*

#### § 42. Conformal Representations Determined by Singly Periodic Functions

The conformal representations determined by the functions  $e^z$ ,  $\sin z$ ,  $\cos z$  can now be investigated in detail by means of the results of the preceding paragraph. For the first of these functions it therefore follows from those results that :

I. *The function  $w = e^z$  takes on every finite value  $w$ , different from zero, at an infinite number of points of the  $z$ -plane, all of which follow from any one of them by addition and subtraction of arbitrary integral multiples of  $2\pi i$ .*

Let us draw then in the  $z$ -plane two parallels to the  $x$ -axis at a distance  $2\pi$  from each other and regard one of these lines as belonging to the strip bounded by them, the other not; in this way each point of any such set of points occurs just once in the strip. Hence every such strip is mapped exactly upon the whole  $w$ -plane by the function  $w = e^z$ ; by the general theorem of § 34 the representation is conformal. Thus, in the terminology introduced in VI, § 17, we say :

II. *Every strip bounded by two lines parallel to the  $x$ -axis and drawn at a distance  $2\pi$  from each other can be looked upon as a fundamental region of the function  $e^z$ . We shall call such a strip a period strip of the function.*

Besides, it follows from its definition in terms of a permanently converging power series with real coefficients, that the function  $e^z$

has the property that it takes on real values for real values of  $z$ , and conjugate imaginary values for conjugate imaginary values of  $z$ ; it is therefore a *symmetric* automorphic function in the sense of the definition given in X, § 18. Accordingly, we can regard two pieces of the period strip symmetrical to each other with reference to the  $x$ -axis as its fundamental region. This is seen to

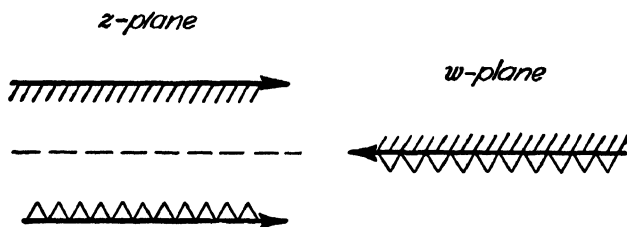

FIG. 19

be true in this case if we bound the strip by the two straight lines  $y = \pi$  and  $y = -\pi$ . If we map this strip upon the  $w$ -plane by  $w = e^z$ , it will have a cut along the negative real axis and the two "banks" of this cut will correspond to the two borders of the strip. This is shown in Fig. 19 and in the former figures 10, 11.

We determine also the curves of the  $w$ -plane which correspond to the parallels to the axes of the  $z$ -plane:

III. *From the conformal representation determined by  $w = e^z$  we obtain the following results: To the parallels to the  $y$ -axis ( $x = \text{const.}$ ) correspond the circles of the  $w$ -plane:*

$$(1) \quad u^2 + v^2 = e^{2x}$$

*whose radii increase in geometrical progression while the abscissas of the straight lines increase in arithmetical progression; to the parallels to the  $x$ -axis ( $y = \text{const.}$ ) correspond the rays of the  $w$ -plane:*

$$(2) \quad u \sin y - v \cos y = 0$$

*which form equal angles with each other providing the straight lines parallel to the  $x$ -axis follow each other at equal distances.*

For the functions sine and cosine, we also have period strips of breadth  $2\pi$ ; however, in this case, the strips are bounded by parallels to the  $y$ -axis as for  $e^{iz}$ . But while  $e^{iz}$  takes on every value in such a strip once, sine and cosine take on every value in it *twice*. This follows from the fact that these functions have transformations into themselves other than their periodicity as the following equations show :

$$(3) \quad \sin(\pi - z) = \sin z$$

$$(4) \quad \cos(-z) = \cos z.$$

But they cannot take on this same value oftener, since, for example:

$$(5) \quad \cos z = \frac{e^{2iz} + 1}{2e^{iz}}$$

is a rational function of the second degree in  $e^{iz}$  and hence (VII, § 20) cannot take on one and the same value for more than two values of  $e^{iz}$ .

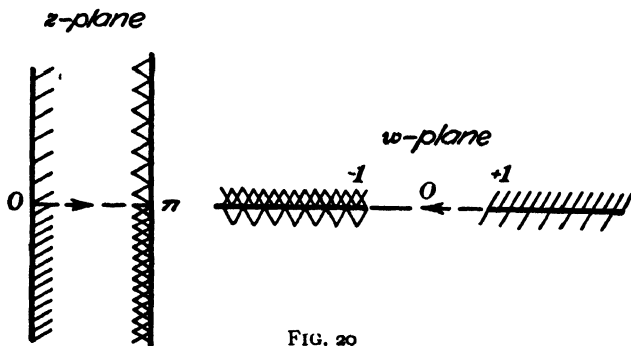

FIG. 20

The period strip is in this case, therefore, not a fundamental region; but, since sine and cosine are symmetric automorphic functions, we obtain such a fundamental region for the cosine according to XI, § 18, by bounding it by  $x=0$  and  $x=\pi$ ; cf. Fig. 20. The *w-plane* in this representation has a cut from  $-1$

to  $-\infty$  and from  $+1$  to  $+\infty$ . The strip bounded by  $x = -\frac{\pi}{2}$  and  $x = +\frac{\pi}{2}$  is a fundamental region for the sine.

If we put

$$(6) \quad u + iv = \cos(x + iy),$$

we obtain

$$(7) \quad u = \frac{e^y + e^{-y}}{2} \cdot \cos x, \quad v = -\frac{e^y - e^{-y}}{2} \cdot \sin x,$$

and hence

$$(8) \quad \left( \frac{2u}{e^y + e^{-y}} \right)^2 + \left( \frac{2v}{e^y - e^{-y}} \right)^2 = 1,$$

$$\left( \frac{u}{\cos x} \right)^2 - \left( \frac{v}{\sin x} \right)^2 = 1; \quad \text{that is,}$$

IV. In the map determined by  $w = \cos z$ , parallels to the axes of the  $z$ -plane correspond in the  $w$ -plane to confocal ellipses and hyperbolas whose foci are at the points  $\pm 1$ .

### § 43. Poles or Non-essential Singular Points

Up to this time we have limited the investigation of functions of a complex argument to such domains in which the function to be investigated was regular; we proceed now to the investigation of the case for which there are, in the domain under consideration, *particular points to be excepted*, at which there is either no value of the function given originally, or the given value of the function in its relation to the adjacent values no longer satisfies all the hypotheses. Let us fix in mind then one such exceptional point; without loss of generality we may suppose that it is the point  $z = 0$ .

The simplest case would be where the function can be made to satisfy all the conditions in the neighborhood of the origin, itself included, *by changing the value which the function takes on*

at the origin (or by selecting such a value when according to the original definition the function has no definite value for the value  $z = 0$  of the argument). We then say: *the given value of the function exhibits a removable discontinuity at the origin.*

An example\* of this is furnished by the rational function of § 20, which was given in such form that numerator and denominator had an additional factor dependent on  $z$ . We may exclude such removable discontinuities, and will do so in what follows, by supposing the original definition, if it included such singularities, to be already modified or supplemented accordingly.

Furthermore, we have already become acquainted with a definite kind of singular points of rational integral functions to which we gave the name pole. Hence the following general definition:

I. *When a function  $f(z)$  of a complex variable is regular in the neighborhood of a point  $z = 0$ , the point itself excluded; and when further an integer  $n$  can be found such that the product:*

$$(1) \quad \dots \quad z^n \cdot f(z) = f_1(z)$$

*can be made a function regular at  $z = 0$  BY ASSIGNING TO IT AT  $z = 0$  A DEFINITE FINITE VALUE DIFFERENT FROM ZERO, then we say that  $z = 0$  is a pole† of  $f(z)$  of order  $n$ .*

The reciprocal of such a function is in general not defined at the point  $z = 0$ ; but it follows that:

II. *If we assign the value zero to the reciprocal function  $\frac{1}{f(z)}$  at the point  $z = 0$ , there is defined in this way a function regular in a certain neighborhood about the point  $z = 0$ , this point itself included.*

\* For other illustrations of removable discontinuities see examples 8 and 9, at the end of § 47. — S. E. R.

† According to WEIERSTRASS "ausserwesentlich singulärer Punkt," that is, "non-essential singular point."

According to XII, § 38, we can assign a neighborhood about the point  $z = 0$  in which  $f_1(z)$  is everywhere different from zero and therefore  $\frac{1}{f_1(z)}$  is regular. Accordingly,

$$\frac{1}{f(z)} = z^n \cdot \frac{1}{f_1(z)}$$

is regular there.

Since  $f_1(z)$  can be developed, according to III, § 37, in a series of the form :

$$f_1(z) = a_0 + a_1z + \dots + a_nz^n + \dots$$

it follows that :

III. *A function  $f(z)$ , which has a pole of order  $n$  at  $z = 0$ , has a development in this neighborhood of the form :*

$$(2) f(z) = a_0z^{-n} + a_1z^{-n+1} + \dots + a_{n-1}z^{-1} + a_n + a_{n+1}z + \dots$$

Further, from this and XII, § 38, we have :

IV. *About every pole of a function  $f(z)$ , we can draw a circle of so small a radius that neither another pole nor a zero of the function lies in it.*

**§ 44. Behavior of a Function of a Complex Argument at Infinity.  
The Fundamental Theorem of Algebra**

In order to investigate the behavior of a function  $f(z)$  of a complex argument  $z$  at infinity, let us transfer the neighborhood of the point  $\infty$  of the  $z$ -sphere to the neighborhood of the zero-point of the  $z'$ -sphere by means of the substitution  $z' = \frac{1}{z}$ ,  $z = \frac{1}{z'}$  as in the special case of rational functions (§ 21), and consider  $f(z) = f\left(\frac{1}{z'}\right) = \phi(z')$  as a function of  $z'$ . Thus :

I. *The expression, "A function  $f(z)$  has such and such a property at infinity" means that  $\phi(z') = f\left(\frac{1}{z'}\right)$ , considered as a function of  $z'$ , has this property in the neighborhood of the point  $z' = 0$ .*

For  $z' = 0$  itself, this does not yet define the symbol  $\phi(z')$ , but when it is possible to make  $\phi(z')$  regular in the neighborhood of the origin by a suitable selection of a value for  $\phi(0)$  (cf. the previous paragraphs), then we say,  $f(z)$  is regular at infinity. From this definition and from III, § 37, it follows directly that:

II. *A function regular at infinity can be developed in a series:*

$$(1) \quad f(z) = a_0 + a_1z^{-1} + a_2z^{-2} + \dots + a_nz^{-n} + \dots$$

*of powers of  $z$  with negative, integral, decreasing exponents, which converges absolutely outside of a certain circle with  $z=0$  as a center. Conversely, such a series always represents a function regular at infinity.*

Likewise, we obtain the following theorem from III, § 43:

III. *If a function has a pole at infinity, it can be developed in a series of the form:*

$$(2) \quad f(z) = a_{-n}z^n + a_{-n+1}z^{n-1} + \dots + a_{-2}z^2 + a_{-1}z + \\ a_0 + a_1z^{-1} + a_2z^{-2} + \dots + a_nz^{-n} + \dots$$

We now take up a theorem due to LIOUVILLE which is fundamental for all further detailed investigations in function theory:

IV. *A function of a complex argument regular over the entire sphere is necessarily a constant.*

If  $f(z)$  is regular at infinity, there is then a quantity  $M_1$  having the property that  $|f(z)| < M_1$ , whenever  $|z|$  is greater than a definite number  $R$ . If  $f(z)$  is regular everywhere except at infinity, then Theorem V of § 39 is applicable. But the number  $M$  appearing in that theorem is  $< M_1$ , whenever  $r > R$ ; the coefficients  $a_n$  of the development of  $f(z)$  in a MACLAURIN'S series must then be smaller than  $M_1 \cdot r^{-n}$  for any value of  $r$  how-

ever large. But that is not possible for any positive value of  $n$  while  $a_n$  is not equal to 0. Therefore  $f(z)$  must reduce to  $a_0$ .

Theorem IV is thus important in connection with functions of which only the properties but no analytic expressions are known, since we are frequently able to find such expressions with the help of this theorem. The two following theorems are the first examples of this :

V. *A function, which is regular everywhere except at infinity and has an  $n$ -fold pole at infinity, is a rational integral function of the  $n$ th degree.*

If it has an  $n$ -fold pole at infinity, a development of the form (2) is possible there. Thus if we put

$$(3) \quad \psi(z) = a_{-n}z^n + a_{-n+1}z^{n-1} + \dots + a_{-1}z + a_0$$

and form the difference  $f(z) - \psi(z)$ , it is regular everywhere except at infinity ; for,  $f(z)$  is regular according to hypothesis and  $\psi(z)$  according to § 31. But it is regular also at infinity according to II and is therefore a constant according to IV, and in fact = 0, since it is equal to zero for  $z = \infty$ . Therefore  $f(z)$  is equal to the rational integral function  $\psi(z)$ . Q.E.D.

VI. *A function  $f(z)$  which is regular everywhere over the whole sphere with the exception of a finite number of poles is a rational function.*

Let  $a_\nu$  ( $\nu = 1, 2, \dots, n$ ) be the poles of  $f(z)$  on the finite part of the sphere,  $k_\nu$  their order ; let

$$(4) \quad \psi_\nu(z) = \sum_{m=1}^{k_\nu} \frac{a_\nu}{(z - a_\nu)^m}$$

be the terms with negative exponents in the development in a series valid for the neighborhood of  $a_\nu$  (III, § 43). If we form

then the rational function :

$$(5) \quad \psi(z) = \sum_{v=1}^n \psi_v(z),$$

the difference  $f(z) - \psi(z)$  is regular everywhere except at infinity, even at the points  $a_1, a_2, \dots, a_n$ ; at infinity, it has a pole or is regular according as  $f(z)$  has the one or the other. It is, therefore, a rational integral function  $\chi(z)$  according to V or a constant (a rational integral function of zero degree) according to IV. Therefore,  $f(z)$  is equal to the rational function

$$\psi(z) + \chi(z). \quad \text{Q.E.D.}$$

If we apply this theorem to the reciprocal of a rational integral function of the  $m$ th degree  $g(z)$ ,  $\chi(z)$  is in any case a constant; and if we next reduce  $\psi(z) + \chi(z)$  to a common denominator, a quotient of two polynomials  $\frac{h_1(z)}{h_2(z)}$  is obtained whose denominator  $h_2(z)$  is of the degree  $k = k_1 + k_2 + \dots + k_n$  and whose numerator  $h_1(z)$  is at most of this degree. From the equation :

$$(6) \quad \frac{1}{g(z)} = \frac{h_1(z)}{h_2(z)},$$

or

$$h_2(z) = h_1(z) \cdot g(z),$$

it follows then that  $k$  must be  $\geq m$ . Thus the number of poles of  $\frac{1}{g(z)}$ , that is, the number of zeros of  $g(z)$  (each counted as often as its order indicates), is at least equal to  $m$ ; and since it cannot also be greater than  $m$  according to II, § 19, we have proved the *fundamental theorem of algebra* :

VII. *Every algebraic equation of the  $m$ th degree has exactly  $m$  roots in the field of complex numbers of the form  $a + bi$ , where multiple roots are counted according to their order of multiplicity.\**

\* Cf. GORDAN'S proof, *Invarianten*, Vol. I, p. 166; also OSGOOD, *Lehrbuch der Funktionentheorie*, Vol. I, p. 185; BOCHER, *Am. Jour. of Math.*, Vol. 17 (1895), p. 260, and *Bull. Amer. Math. Soc.*, 2d Series, Vol. I (1895), p. 205; GOURSAT-HEDRICK, *Mathematical Analysis*, Vol. I, pp. 3, 131, 291.—S. E. R.

Let us inquire now how a transcendental integral function behaves at infinity. We can at present answer this question in part from the behavior of the singly periodic functions investigated in §§ 40-42. If we draw about the origin a circle with a radius however large, an infinite number of parallel strips will always remain entirely outside of it; therefore a periodic function takes on every value which it takes on at all, an infinite number of times in any arbitrary neighborhood of the point  $\infty$ . For example,  $e^z$  takes on every value an infinite number of times in any arbitrary neighborhood of the point  $\infty$ , excepting alone the two values 0 and  $\infty$ . But it also approaches arbitrarily near to these two values in any neighborhood of the point  $\infty$ , however small.

We show now that the behavior of every transcendental integral function at infinity is similar to that of  $e^z$ ; and that every such function takes at infinity values arbitrarily large in addition to other values; or more precisely:

VIII. *Given a transcendental integral function  $f(z)$  and a positive number  $M$  (however large), there are then always values of  $z$  outside of every circle (with a radius arbitrarily large), for which  $|f(z)| > M$ .*

If that were not the case outside of a circle of radius  $R$ , then, by applying Theorem V, § 39, for a circle of radius  $r > R$ , we could prove that the coefficients in the MACLAURIN development of  $f(z)$  are respectively smaller than  $Mr^{-n}$ . But from that it would follow as in the proof of IV, that they must all be zero.

The transcendental integral functions thus share this property with the rational integral functions; but they differ from them as follows:

IX. *Given a transcendental integral function  $f(z)$  and a positive number  $\epsilon$  (however small), then there are always points outside of*

every circle (with a radius arbitrarily large), at which  $f(z)$  is SMALLER than  $\epsilon$ .

This is self-evident if there are always zeros of  $f(z)$  outside of every circle. But if all the zeros of  $f(z)$  lie inside of a circle of radius  $R$ , there can be only a finite number of them according to IX, § 39, and we designate them then by  $a_1, a_2, \dots, a_n$ . These points are poles of the function  $\frac{1}{f(z)}$ ; as in the proof of VI (equation 4), let  $\psi_\nu(z)$  be the sum of the terms with negative exponents in the development of this function in a series valid for the neighborhood of  $a_\nu$ . It then follows here as there, that

$$(7) \quad \frac{1}{f(z)} - \sum_{\nu=1}^n \psi_\nu(z)$$

is everywhere regular except at infinity. This difference is then a transcendental integral function which cannot be reduced to a constant since otherwise  $f(z)$  would be a rational function, contrary to the hypothesis.\* According to VIII, therefore, this difference takes on values arbitrarily large outside of every circle; since every  $\psi^\nu(z)$ , and therefore their sum, becomes indefinitely small at infinity, it follows that  $\frac{1}{f(z)}$  becomes arbitrarily large there; that is,  $f(z)$  takes on values arbitrarily small at infinity. Q.E.D.

If Theorem IX be applied to  $f(z) - c$ , where  $c$  designates an arbitrary constant, we have the following general theorem:

X. *A transcendental integral function approaches arbitrarily near to every value in the neighborhood of the point  $\infty$ .*

We must not understand this theorem to mean that such a function *actually takes on* every value in the neighborhood of  $z = \infty$ .

\* That a rational fractional function cannot at the same time be a transcendental integral function follows from Theorem VII.

This is shown by the exponential function, which is neither 0 nor  $\infty$  at any assignable point.\*

The definition of a transcendental integral function fails for  $f(z) = \infty$ . On account of Theorem X there is no object in trying to complete this definition to conform with I, § 21, by giving it a definite value even at  $z = \infty$ . On the contrary, it is possible at times to obtain a definite value in the limit when the variable  $z$  is allowed to approach the point  $\infty$  *along an assigned path*. Thus, for example,  $e^z$  converges to  $\infty$  when  $z$  approaches  $\infty$  along the axis of positive real numbers and converges to zero when  $z$  approaches  $\infty$  along the axis of negative real numbers. On the other hand, its real part as well as its imaginary part fluctuates continually between  $-1$  and  $+1$  when  $z$  approaches infinity through purely imaginary values, positive or negative.

#### EXAMPLES

1. Expand  $\frac{1}{z-1}$  for the domain at infinity; that is, in powers of  $\frac{1}{z}$  valid for the domain outside of the circle whose center is at  $z = 0$  and radius 1. (Cf. III, § 43, II, § 44.)

2. Expand  $\frac{(z+1)}{(z+2)(z+3)}$ ,  $\frac{(z+1)(z+2)}{(z+3)(z+4)}$  for the domain at infinity.

3. What are the poles of  $\frac{1}{z^2(z-1)^3}$ ? Expand this function in a circle about the point  $z = 0$ . Also in a circle about  $z = 1$ .

4. Expand  $\frac{z(z+1)}{z+2}$  as in III, § 44.

\* PICARD has shown (Par. C. R. 90, 1879) that there is never more than one finite value which will not really be assumed by a transcendental integral function in the neighborhood of  $z = \infty$ . A proof of this theorem by elementary means is given by E. BOREL, Par. C. R. 122, 1896, and *Leçons sur les fonctions entières*, Paris, 1900, p. 103.

5. Give the domain of convergence for the expansion of  $\frac{\sin z}{z+1}$ . Find this expansion.

6. What is the domain of convergence for the expansion of  $\frac{\sin z}{z+2}$  in powers of  $z+2$ ? Give the expansion.

### § 45. Cauchy's Theorem on Residues

We became acquainted in IV, § 35, with the theorem that the value of the integral

$$\int f(z) dz$$

is always equal to zero if it is taken along the boundary of a domain in which the function  $f(z)$  is regular; we now inquire as to the value of this integral when a finite number of poles lie in the domain.

Let us consider first a domain in which there is only one pole, and let it be at the point  $z = 0$ . According to VII, § 35, we can then deform the path of integration into a circle about the point  $z = 0$  with a radius arbitrarily small without changing the value of the integral. But, according to III, § 43, in the neighborhood of the point  $z = 0$ ,

$$f(z) = a_{-n}z^{-n} + a_{-n+1}z^{-n+1} + \cdots + a_{-2}z^{-2} + a_{-1}z^{-1} + f_1(z),$$

where  $f_1(z)$  designates a function regular in the neighborhood of the point  $z = 0$ ; we thus obtain:

$$\int f(z) dz = a_{-n} \int z^{-n} dz + \cdots + a_{-1} \int z^{-1} dz + \int f_1(z) dz$$

all of these integrals being taken along the given small circle. The last one of these integrals is zero according to a previous theorem (IV, § 35), the others have already been evaluated in

VIII, § 35. Introducing here the values so found, we obtain :

$$(1) \quad \int f(z) dz = 2 \pi i \cdot a_{-1}.$$

Definition :

I. *The coefficient of the  $(-1)^n$  power of  $(z - a)$  in the development of a function in the neighborhood of the pole  $z = a$  is called the residue of the function at this pole.*

Accordingly, equation (1) can be stated as follows :

II. *The integral  $\int f(z) dz$ , taken around a domain in which the function is regular with the exception of a pole, is equal to  $2 \pi i$  times the residue of the function at this pole.*

But if we have a domain in which several poles lie, we divide it into a number of subdomains such that each of them contains only one pole, apply Theorem II to each of these subdomains, and add the results. We thus integrate twice along each dividing line between subdomains but in opposite directions (and always so that the subdomain under consideration lies to the left). The

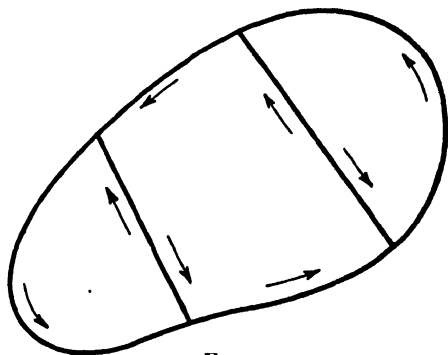

FIG. 21

integrals taken along the inner boundaries accordingly cancel out entirely (cf. VII, § 29) and only the integral along the outside boundary of the given domain remains. We have thus the theorem :

III. *The integral  $\int f(z) dz$ , taken along the boundary of a domain in which the function is regular except at a finite number*

of poles, is equal to  $2\pi i$  times the sum of the residues of the function at these poles.

Up to this time we have tacitly assumed that the domain under consideration excluded entirely the point at infinity; in considering also domains which contain the point  $\infty$  as an inner point, we must first determine what is to be understood by the residue of a function at the point  $\infty$ . We must therefore observe that when  $z$  is replaced by  $z'^{-1}$  (cf. § 21),  $dz$  is replaced by  $-z'^{-2}dz'$ ; the integral  $\int f(z)dz$  is then replaced by  $-\int z'^{-2}\phi(z')dz'$ ; and this integral taken along a closed curve is then zero if  $z'^{-2}\phi(z')$ , that is,  $z^2 \cdot f(z)$  is regular inside of this curve. The fundamental theorem of § 35 must, therefore, be modified as follows for a domain which contains the point  $\infty$  within it:

IV. *The integral  $\int f(z)dz$ , taken along a closed curve which incloses the point  $\infty$ , is equal to zero if  $z^2 \cdot f(z)$  is regular inside of the domain inclosed by this curve and containing the point  $\infty$ .*

But if  $z^2 \cdot f(z)$  is not regular inside of this curve, it follows in consideration of the integral  $\int f(z)dz = -\int \phi(z') \cdot z'^{-2} \cdot dz'$  that:

V. *In the application of Theorems II and III to a domain which contains the point  $\infty$  within it, we are to take as the residue at this point the coefficient of  $z^{-1}$ \* with the opposite sign in the development (III, § 44).*

Every closed curve on a sphere divides it into two parts and can be looked upon as the boundary of each of these parts. If a function be regular in each of these parts except for particular poles — which is only the case for rational functions according

\* Not of  $z+1$ .

to VI, § 44 — we can apply Theorem III to each of the parts. The same integral appears both times, but the direction of integration is opposite (that is, taken each time so that the domain considered lies to the left). If we now add the two results, the integrals disappear, and we have the following theorem:

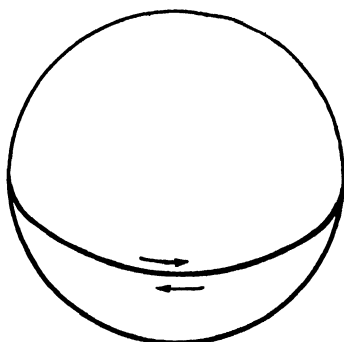

FIG. 22

VI. *The sum of all the residues of a rational function is always equal to zero.*

**EXAMPLES**

1. Consider the function  $\frac{1}{(z^3 + 1)^2}$ . What are its poles? Find its residues at the points  $-1, -\omega, -\omega^2$ . ( $=\frac{2}{3}, \frac{2}{3}\omega, \frac{2}{3}\omega^2$ , respectively.) Find the value of  $\int \frac{1}{(z^3 + 1)^2} dz$  taken along a semicircle and its diameter, having its center at the origin and including the two points  $-\omega, -\omega^2$  ( $\omega$  is a primitive 3d root of unity).

*Ans.*  $-\frac{4}{3}\pi i$ .

2. If in the CAUCHY formula  $f(a) = \frac{1}{2\pi i} \int_{\Gamma} \frac{f(z) dz}{z - a}$ ,  $z - a$  is replaced by  $(z - a_1) \cdot (z - a_2) \cdots (z - a_v)$ , prove that

$$\frac{1}{2\pi i} \int_{\Gamma} \frac{f(z) dz}{(z - a_1)(z - a_2) \cdots (z - a_v)} = \sum_{\lambda=1}^v \frac{f(a_{\lambda})}{f'(a_{\lambda})} \cdot \frac{1}{(z - a_{\lambda})}$$

3. If  $f(z)$  has a simple zero  $z = a$  but no pole in the finite domain  $S$  bounded by  $C$ , then

$$a = \frac{1}{2\pi i} \int_C z \cdot \frac{f'(z) dz}{f(z)}$$

4. Show that the residue of

$$\frac{A}{(z-a)(x-z)}$$

at the point  $z = a$  is  $\frac{A}{(x-a)}$ .

Show also that the residue of the function

$$\frac{A}{(z-a)^m(x-z)}$$

at this same point is  $\frac{A}{(x-a)^m}$ .

5. Determine the residue, also the logarithmic residue of the function

$$\frac{z}{(z-a)(z-b)^2}$$

at the point  $z = b$ .

#### § 46. The Theorem concerning the Number of Zeros and of Poles.

##### A Second Proof of the Fundamental Theorem of Algebra

If  $f(z)$  is a function of a complex argument  $z$  and  $f'(z)$  its first derivative, we shall call  $\frac{f'(z)}{f(z)}$  the *logarithmic derivative* of  $f(z)$ ; the reason for this nomenclature will appear later. Other theorems concerning the function  $f(z)$  may be obtained if we use the logarithmic derivative instead of  $f(z)$  itself in the application of the theorems of the above paragraph; for this purpose a few theorems concerning the logarithmic derivative are needed:

I. If  $f(z)$  is regular in the neighborhood of the point  $z_0$  and different from zero at that point, then  $\frac{f'(z)}{f(z)}$  is regular there.

For, in that case,  $\frac{1}{f(z)}$  (according to X, § 38) and also  $f'(z)$  (according to VII, § 38) are regular in the neighborhood of  $z_0$ .

II. *If  $f(z)$  is regular in the neighborhood of a point  $z_0$  and has an  $m$ -fold zero at that point, then  $\frac{f'(z)}{f(z)}$  has a simple pole at  $z_0$  and its residue there is  $m$ .*

For then we can put (A. A. § 24)

$$(I) \quad f(z) = (z - z_0)^m \cdot f_1(z)$$

where  $f_1(z)$  is understood to be a function regular in the neighborhood of  $z_0$  and different from zero at  $z_0$ ; it follows from this that:

$$(2) \quad \frac{f'(z)}{f(z)} = \frac{m}{z - z_0} + \frac{f_1'(z)}{f_1(z)}.$$

Since  $\frac{f_1'(z)}{f_1(z)}$  is regular in the neighborhood of  $z_0$  according to I, the correctness of Theorem II is evident from this equation. It is proven in the same way that:

III. *If  $f(z)$  has an  $m$ -fold pole at  $z = z_0$ ,  $\frac{f'(z)}{f(z)}$  has a simple pole with the residue  $-m$  at that point.*

The proof of Theorems I to III is understood to be valid for a point situated in the finite part of the plane. For the point at infinity Theorem I is unchanged, but in Theorems II and III only the statements relating to the values of the residues remain true, not the statement that  $\frac{f'(z)}{f(z)}$  has a simple pole. On the contrary, the logarithmic derivative is regular at infinity even in these cases. This is however irrelevant in the application which we now wish to make since we are concerned only with the residues.

By applying Theorem III, § 45, to  $\frac{f'(z)}{f(z)}$  we obtain the following theorem :

IV. *The integral* 
$$\frac{1}{2\pi i} \int \frac{f'(z)}{f(z)} dz$$

*taken in the positive sense along the boundary of a domain in which the function  $f(z)$  is everywhere regular except at poles, is equal to the number of zeros of  $f(z)$  in this domain diminished by the number of poles; every zero and every pole is to be counted here as often as its order of multiplicity indicates.*

Further, we find from Theorem VI of § 45 that :

V. *Every rational function becomes zero as often as infinite upon the sphere* (which is only another formulation of Theorem III, § 21);

and if we apply it to  $f(z) - c$  instead of  $f(z)$ , we find that :

VI. *A rational function takes on any arbitrary value  $c$  just as often as it becomes infinite.*

In these theorems too, multiple zeros or poles are to be counted according to their order of multiplicity; the expression " $f(z)$  takes on the value  $f(z) = c$   $n$  times at the point  $z = a$ ," means that  $c$  is the first term in the development of  $f(z)$  in powers of  $z - a$ , for which terms with 1, 2,  $\dots$ ,  $(n - 1)$ <sup>th</sup> powers of  $(z - a)$  do not appear, but the term  $(z - a)^n$  is present.

In particular, a rational integral function of the  $n$ th degree is everywhere regular except at infinity and has an  $n$ -fold pole at infinity; it therefore follows from Theorem V that :

VII. *Every rational integral function of the  $n$ th degree has  $n$  zeros; or, expressed otherwise :*

VIII. *Every algebraic equation of the  $n$ th degree has  $n$  roots.*

We thus have a second proof of the *fundamental theorem of algebra* (cf. VII, § 44).

It follows further from this that a rational fractional function has as many poles as its degree indicates (II, § 20). For, if the degree  $m$  of the numerator is not greater than the degree  $n$  of the denominator, its degree is  $n$ ; it is then regular at infinity and has  $n$  poles in the finite part of the plane. But if  $m > n$ , its degree is equal to  $m$  and it has an  $(m - n)$ -fold pole at infinity in addition to the  $n$  poles in the finite part of the plane. From Theorem VI it thus follows that :

IX. *Every rational function takes on any arbitrary complex value as often as its degree indicates.*

We make further use of Theorem IV in order to deduce an important extension of Theorem VIII of § 38. Let  $w = f(z)$  be a function regular in a circle about the origin and  $f'(0) \neq 0$ ; without loss of generality, we may assume that  $w = 0$  for  $z = 0$ , since this can always be obtained by a parallel translation of the  $w$ -plane. We can then take  $r$  so small, according to VIII, § 39, that no other zeros of  $f(z)$  lie inside or upon the circumference of a circle  $\Gamma$  of radius  $r$ , and thus, according to IV :

$$(3) \quad \frac{1}{2\pi i} \int_{\Gamma} \frac{f'(z)}{f(z)} dz = 1.$$

If therefore  $m$  be the smallest value which  $|f(z)|$  assumes on  $\Gamma$ , and  $w_1$  any value of  $w$  whose absolute value is smaller than  $m$ , then the number of roots which the equation

$$f(z) = w_1$$

has inside of  $\Gamma$  is :

$$(4) \quad n = \frac{1}{2\pi i} \int_{\Gamma} \frac{f'(z)}{f(z) - w_1} \cdot dz.$$

If we put

$$(5) \quad 1 - \frac{w_1}{f(z)} = \psi(z) = t,$$

it follows that

$$\psi'(z) = \frac{w_1 \cdot f'(z)}{[f(z)]^2}$$

$$\frac{\psi'(z)}{\psi(z)} = \frac{w_1 \cdot f'(z)}{f(z)[f(z) - w_1]} = -\frac{f'(z)}{f(z)} + \frac{f'(z)}{f(z) - w_1}.$$

Equations (3) and (4) therefore give:

$$n - 1 = \frac{1}{2\pi i} \int_{\Gamma} \frac{\psi'(z)}{\psi(z)} dz = \frac{1}{2\pi i} \int_C \frac{dt}{t},$$

the last integral taken along that curve  $C$  of the  $t$ -plane which corresponds by means of equation (5) to the circle  $\Gamma$  of the  $z$ -plane. But since  $|f(z)| \geq m > |w_1|$  on  $\Gamma$  according to the hypothesis,  $C$  can never be so far from the point  $t = 1$  that it could inclose the point  $t = 0$ ; this integral is then zero,  $n = 1$ , and the equation  $f(z) = w_1$  has one and only one root inside of  $\Gamma$ . But it follows from VIII, § 39, that we can also describe in the  $z$ -plane a circle about the origin of so small a radius  $\rho$  ( $< r$ ) that  $|f(z)|$  in it takes on only values which are  $< m$ . The theorem is therefore as follows:

X. *If  $w = f(z)$  is a function of  $z$  regular in the neighborhood of the point  $z = 0$  and  $f'(0) \neq 0$ , a circle of so small a radius can then be drawn about this point that  $w$  takes on different values at different points in it, and that (VIII, § 38) the values which  $w$  takes on in this circle cover a region  $U$  of the  $w$ -plane inside of which, conversely,  $z$  is a regular function of  $w$ .*

For the actual construction of this function in individual cases, we can make use of the method of undetermined coefficients (A. A. § 78, § 79); or we could use a theorem, also useful otherwise, obtained by applying Theorem III of § 45 to  $\frac{z \cdot f'(z)}{f(z)}$ .

This function is regular where  $f(z)$  is regular and different from

zero; at an  $m$ -fold zero  $a$  of  $f(z)$  it has the residue  $ma$ , at an  $m$ -fold pole  $b$ , the residue  $mb$ . (Both are true for  $a = 0$ ,  $b = 0$ , respectively but not for  $a = \infty$ , or  $b = \infty$ .) Therefore, we obtain :

XI. *The integral* 
$$\frac{1}{2\pi i} \int \frac{z \cdot f'(z)}{f(z)} dz,$$

*taken in the positive sense along the boundary of a domain lying in the finite part of the plane in which  $f(z)$  is everywhere regular except at poles, is equal to the sum of the zeros of  $f(z)$  in this domain diminished by the sum of the poles, multiple zeros or poles being counted as often as their orders of multiplicity indicate.*

If, instead of using the function  $f(z)$  itself, we apply this theorem to the function  $f(z) - w$  and to the domain in which this function has only one zero and no poles, we obtain the following theorem :

XII. *The integral* 
$$\frac{1}{2\pi i} \int \frac{z \cdot f'(z)}{f(z) - w} dz,$$

*taken in the positive sense along the circle defined in Theorem X, represents the solution of the equation*

$$f(\zeta) = w \quad .$$

*for  $\zeta$ ; and in fact that solution which belongs to the region  $U$  defined in Theorem X.*

If we expand here under the integral sign in increasing powers of  $w$  and then integrate term by term, we obtain for this solution a development in powers of  $w$  which converges inside of the largest circle that can be drawn about the zero point of the  $w$ -plane and which belongs entirely to the region  $U$ .

In connection with these conclusions we discuss another theorem which appeared earlier in a different discussion of this theory. The integral

$$\int u dv$$

taken along the boundary of a domain in the  $uv$ -plane, represents, as will be taken for granted here, the area of this domain; and it has the positive or the negative sign according as the boundary is described in the positive or in the negative sense in the process of integration. If we introduce  $x$  and  $y$  as variables of integration in this integral, regarding  $u$  and  $v$  as functions of  $x$  and  $y$ , we obtain the integral:

$$\int \left( u \frac{\partial v}{\partial x} dx + u \frac{\partial v}{\partial y} dy \right)$$

taken along the corresponding curve of the  $xy$ -plane. If this curve incloses a domain whose map upon the corresponding domain of the  $uv$ -plane is reversibly unique, then the value of the integral is positive when taken around the domain of the  $xy$ -plane in the positive sense, and negative in the opposite case if the sense of the angle remains unchanged throughout the mapping. The first is always the case according to the last theorems if  $u + iv$  is an analytic function of  $x + iy$  and the domain is sufficiently small. But since an integral taken over an arbitrary curve can always be replaced as in § 29 by a sum of integrals over sufficiently small curves, it follows that:

XIII. *If  $u + iv$  is a regular function of  $x + iy$  over the whole domain inclosed by a curve  $\Gamma$ , then the integral*

$$\int u dv$$

*taken in the positive sense along  $\Gamma$ , is always positive.*

The only exception to this theorem occurs when the function  $u + iv$  maps the domain under consideration in the  $x + iy$ -plane not in general upon a domain, but upon a single point, that is, when it is constant. (The conceivable case of mapping the domain of the  $x + iy$ -plane upon a curve of the  $u + iv$ -plane is

not possible on account of the Theorems V, § 26; VIII, § 38; X, § 46.) To include this exception in the formulation of Theorem XIII, we must say "never negative and only zero when  $u + iv$  is constant" instead of "positive."

By means of this theorem we may obtain a second proof of the fundamental Theorem IV, § 44. Theorem XIII is also valid for a part of the sphere which includes the point  $\infty$  as an inner point, provided that the function  $u + iv$  is regular in this domain in the sense of definition I of § 44. However, we must in this case take for positive direction of integration that one for which the domain under consideration, as also the point at infinity, lies to the left.

If now we have a function which is regular over the whole sphere, we can divide the sphere into two parts by any curve which does not go through the point infinity, and we can then apply Theorem XIII to each of these two parts. It then follows first, that the integral cannot be negative when we take the part lying on the finite part of the sphere always to the left; and second, that it cannot be negative when the part containing infinity lies to the left. These two conditions are together possible only when the integral is zero. But then the function  $u + iv$  is constant, Q. E. D.

### § 47. The LAURENT'S Series

In § 36 we studied CAUCHY'S theorem for a domain  $S$  which had *one* bounding curve. We return now to this theorem, studying it for a domain  $S$  in which the function  $f(z)$  is known to be regular and which has *two* bounding curves  $\Gamma, \gamma$  (cf. Fig. 16). Equation (3) of § 36 also holds in this case; but the integration is performed along each of the curves  $\Gamma, \gamma$  in such direction that the domain  $S$  lies to the left. To evaluate this integral in the positive sense along each of the two curves, we must change

the sign of the integral taken along  $\gamma$ ; the given equation then takes the form:

$$(1) \quad f(\zeta) = \frac{1}{2\pi i} \int_{\Gamma} \frac{f(z) dz}{z - \zeta} - \frac{1}{2\pi i} \int_{\gamma} \frac{f(z) dz}{z - \zeta}.$$

Let us study in particular the case for which  $\Gamma, \gamma$  are concentric circles about the origin, and  $S$  the annular domain bounded by these two circles. Then, since  $\zeta$  is understood to be a point within  $S$ ,  $|\zeta| < |z|$  for all elements of the first integral, which can therefore be developed, just as in § 37, in powers of  $\zeta$  with increasing, positive, integral exponents. But for all elements of the second integral and for all points  $\zeta$  within  $S$

$$|\zeta| > |z|;$$

accordingly, the series

$$(2) \quad \frac{1}{z - \zeta} = -\frac{1}{\zeta} - \frac{z}{\zeta^2} - \dots - \frac{z^{n-1}}{\zeta^n} - \dots$$

converges uniformly for all such pairs of values  $(z, \zeta)$ . It may therefore be integrated term by term, and a development is obtained for  $f(\zeta)$  of the form:

$$(3) \quad \begin{aligned} f(\zeta) = & a_0 + a_1\zeta + a_2\zeta^2 + \dots + a_n\zeta^n + \dots \\ & + a_{-1}\zeta^{-1} + a_{-2}\zeta^{-2} + \dots + a_{-n}\zeta^{-n} + \dots \end{aligned}$$

the coefficients of which are expressed by integrals as follows:

$$(4) \quad a_n = \frac{1}{2\pi i} \int_{\Gamma} \frac{f(z) dz}{z^{n+1}}, \quad n = 0, 1, 2, \dots,$$

$$(5) \quad a_{-n} = \frac{1}{2\pi i} \int_{\gamma} z^{n-1} \cdot f(z) dz, \quad n = 1, 2, 3, \dots$$

The two formulas (4) and (5) can be combined into one by making use of Theorem VII, § 35. In consequence of this theorem  $\Gamma$  and also  $\gamma$  can be replaced by any curve  $C$  lying in

this ring, which has the property that it divides the ring into two parts, each of which is annular (one part bounded by  $\Gamma$  and  $C$ , the other by  $C$  and  $\gamma$ ). We then state the resulting theorem as follows, making use of a generally accepted notation for writing series of the form (3):

I. *If a function  $f(z)$  is regular in a ring bounded by two circles concentric about the origin, it can then be developed inside of this annular domain in a convergent series of the form:*

$$(6) \quad f(\zeta) = \sum_{n=-\infty}^{+\infty} a_n \zeta^n$$

*which contains an infinite number of terms in powers of  $\zeta$  with positive as well as negative exponents. The coefficients of this series are expressed by the integrals:*

$$(7) \quad a_n = \frac{1}{2\pi i} \int f(z) z^{-n-1} dz,$$

*taken along any curve  $C$  which surrounds the origin once and lies entirely inside the circular ring.*

Such a series is called a **LAURENT'S Series**.

Particular attention should be given the cases where the radius of  $\Gamma$  is increased indefinitely or that of  $\gamma$  decreased indefinitely, providing the function always satisfies the conditions of the theorem in the domain thus enlarged. Both cases appear at the same time

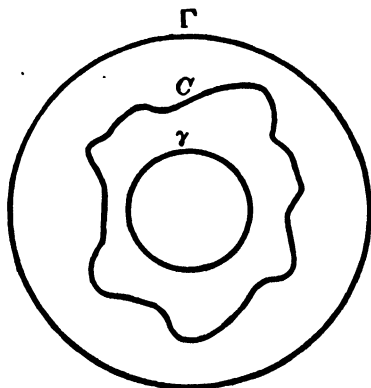

FIG. 23

if we consider a function which is regular over the whole sphere with the single exceptions of the points  $z = 0$  and  $z = \infty$ .

Conversely, let us suppose that for a function  $f(\zeta)$  a development of the form (3) is found which converges inside of the annular domain between two circles  $\Gamma$ ,  $\gamma$ ; and in fact, to fix this hypothesis more precisely, let each of the two series

$$(8) \quad \sum_{n=0}^{\infty} a_n \zeta^n, \quad \sum_{n=1}^{\infty} a_{-n} \zeta^{-n}$$

be convergent inside of the annular domain. Then the first series, according to III, § 38, converges uniformly in every domain which lies entirely inside of  $\Gamma$ , the second converges uniformly in every domain which lies entirely outside of  $\gamma$ . Hence both series converge uniformly on a curve such as  $C$  in Fig. 23, and hence they may be integrated term by term along this curve. Let us do this after first multiplying by  $\zeta^{-m-1}$ ; then, in connection with equations (10) and (11) of § 35, we find:

$$(9) \quad \int_C f(\zeta) \zeta^{-m-1} d\zeta = 2\pi i a_m,$$

and this coincides with (7); that is, therefore,

II. *When a function can be developed in a series of the form (3) which converges in the given sense inside of the circular ring between  $\Gamma$  and  $\gamma$ , then the coefficients have the values given by (7); this development is therefore unique.*

The last statement requires some explanation in order that it may have only the intended meaning. A function may be regular inside of different circular rings, e.g., between  $\gamma_1$  and  $\gamma_2$  between  $\gamma_2$  and  $\gamma_3$ , while upon  $\gamma_2$  there are, for example, poles of the function. Theorem I is then applicable to each of these two rings and two LAURENT'S expansions are thus obtained, one of which converges between  $\gamma_1$  and  $\gamma_2$  and the other between  $\gamma_2$  and  $\gamma_3$ ; and we are, therefore, not to understand Theorem II to

mean that these two expansions must have the same coefficients. On the contrary, Theorem II is applicable only to the expansion inside of one and the same ring.

Thus, for example, we obtain for the expansion

$$\frac{1}{z^2 - 3z + 2} = \frac{1}{z - 2} - \frac{1}{z - 1}$$

inside of the circle of unit radius about the point  $z = c$

$$\frac{1}{2} + \frac{3}{4}z + \frac{7}{8}z^2 + \frac{15}{8}z^3 + \dots;$$

between this circle and the circle of radius 2 :

$$\dots - \frac{1}{z^3} - \frac{1}{z^2} - \frac{1}{z} - \frac{1}{2} - \frac{z}{4} - \frac{z^2}{8} - \dots;$$

outside of the latter:  $+\frac{1}{z^2} + \frac{3}{z^3} + \frac{7}{z^4} + \dots$

The generalization of the theorems of this paragraph to the case where the two concentric circles have not the point  $z = 0$  but any other arbitrary point as center is treated as in VI, § 39, and requires no further explanation.

### EXAMPLES

1. Develop  $\frac{1}{z-3} - \frac{1}{z-1}$  in a series of integral powers of  $z$  valid for the domain in which this function is regular.
2. Expand  $\frac{1}{1-z}$  inside a circle whose center is  $O$ ; that is, expand in powers of  $z$ . How large may the circle of convergence be?
3. Expand  $\frac{1}{z}$  inside a circle whose center is the point  $i$ ; that is, in powers of  $z - i$ .

4. Expand  $\frac{1}{z^2}$  inside a circle whose center is the point  $-1$ ; that is, in powers of  $z + 1$ .

5. Expand  $\frac{1}{z^2}$  inside a circle whose center is the point  $-i$ ; that is, in powers of  $z + i$ .

6. Expand  $\frac{1}{(z + 1)^3}$  in powers of  $z$ . Locate the circle of convergence.

7. Expand  $\frac{1}{(z + 1)^3}$  in powers of  $(z - 1)$ . Locate the circle of convergence.

8. Given the function  $f(z) = \frac{e^z}{z^2 - 1}$ . It has singular points at  $z = \pm 1$  because  $e^z$  is *holomorphic*\* over the whole finite part of the plane. Let us put  $\frac{e^z}{z^2 - 1} = \frac{C_1}{z - 1} + \frac{C_2}{z + 1} + H(z)$  where  $H(z)$  denotes a function holomorphic over the whole finite part of the plane; in other words, it is a function for which *the discontinuities of the original function are removed*. It is required to

- I. Determine  $C_1$  and  $C_2$  and  $H(z)$ ;
- II. Expand  $H(z)$  for a circle whose center is the point  $z = 0$ ;
- III. Expand  $H(z)$  for a circle whose center is the point  $z = 1$ ;
- IV. Expand  $H(z)$  for a circle whose center is the point  $z = -1$ .

$$\begin{aligned} \text{HINT. — } f(z) &= \frac{e^z}{z^2 - 1} = (z - 1)^{-1} \cdot \left\{ \frac{e^z}{z + 1} \right\} \\ &= (z - 1)^{-1} \cdot \{ \text{a series in powers of } (z - 1) \} \\ &= (z - 1)^{-1} \cdot \left\{ \frac{e}{2} + \frac{e}{4}(z - 1) + \frac{e}{2^3}(z - 1)^2 + \dots \right\} \\ &= \frac{e}{2} \cdot \frac{1}{z - 1} + \frac{e}{4} + \frac{e}{2^3}(z - 1) + \dots \end{aligned}$$

\* The term *holomorphic* is used in reference to such functions which are *single-valued, regular (monogenic), and continuous* in the given domain. — S. E. R.

$\therefore \frac{e^z}{z^2 - 1} - \frac{e}{2(z-1)}$  is a function having no singularity at  $z = +1$ .

Thus  $C_1 = \frac{e}{2}$ .

In the same way eliminate also the singularity at  $z = -1$  and find  $C_2$ .

Hence  $\frac{e^z}{z^2 - 1} - \frac{C_1}{z-1} - \frac{C_2}{z+1}$  must be  $H(z)$ .

9. A function having poles of order one at  $a_1$ , of order two at  $a_2$ , and of order three at  $a_3$ , etc., in a domain  $A$ , is generally of the type

$$\frac{C_1}{z-a_1} + \frac{C_2}{(z-a_2)^2} + \frac{C_3}{(z-a_2)^3} + \frac{C_4}{(z-a_3)^3} + \frac{C_5}{(z-a_3)^2} + \frac{C_6}{(z-a_3)} + \dots + H(z),$$

where  $H(z)$  is a function holomorphic in the domain  $A$  containing  $a_1, a_2, a_3, \dots$ , and is thus a function for which the discontinuities of the original function are removed. The constants  $C_1, \dots$ , may be found as in the previous example.

10. Expand  $f(z) = \frac{(z-2) \cdot (z+2)}{(z+1)(z+4)}$

- I. Inside a circle whose center is the point 0 ;
- II. Inside a circle whose center is the point  $\infty$  ;
- III. Inside a circle whose center is the point 2 ;
- IV. In the circular ring which excludes the points  $-1, -4$ .

HINT. — To expand  $f(z)$  in  $B$  put  $f(z) = 1 - \frac{1}{z+1} - \frac{4}{z+4}$ .  
 For  $\frac{1}{z+1}$ ,  $B$  is in the domain at infinity since it is outside of the domain in which  $\frac{1}{z+1}$  is regular; hence  $\frac{1}{z+1}$  is expanded in powers of  $\frac{1}{z}$ . For  $\frac{1}{z+4}$ ,  $B$  is in the domain in

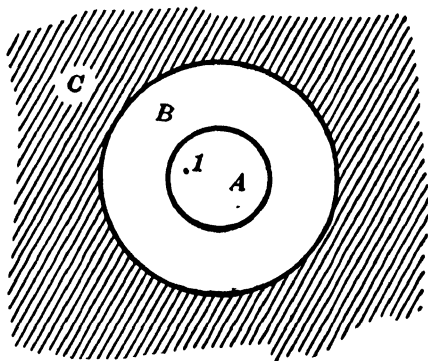

which it is regular; hence expand for a circle with center at  $o$ , that is, in powers of  $z$ . Substitute these in  $f(z)$  and the expansion for the domain  $B$  is obtained.

11. Suppose  $f(z)$  and  $\phi(z)$  have at the point  $z = a$  poles of order  $m$  and  $n$  respectively. What can be said of the behavior of the functions

$$f(z) \cdot \phi(z), f(z) + \phi(z), \frac{f(z)}{\phi(z)}$$

at this point? Discuss all cases.

12. Suppose  $f(z)$  has an  $m$ -fold zero at  $z = a$ . Show that the integral

$$F(z) = \int_a^z f(z) dz$$

has an  $(m + 1)$ -fold zero there.

State the analogous proposition for the integral

$$F(z) = \int_{z_0}^z f(z) dz$$

in the neighborhood of a pole  $a$ .

#### § 48. Behavior of a Regular Function in the Neighborhood of a Critical Point

We may frequently prove that a function is *in general* regular in a domain, but the proof may fail for *particular* points of this domain, so that the question as to the behavior of the function at these critical points remains undetermined. A certain amount of information is furnished in such cases by the LAURENT'S series.

Let the origin be such a point, that is, let the function  $f(z)$  to be investigated be regular at every point of a certain neighborhood of the origin with the exception of the origin itself, concerning which nothing is known. The circle  $\gamma$  used in connection with LAURENT'S theorem can then be taken arbitrarily small.

And when  $|f(z)|$  always remains less than an assignable limit however near  $z$  may approach the origin, it follows that the coefficients  $a_{-n}$  (5, § 47) must all be equal to zero. But then the LAURENT'S expansion of  $f(z)$  represents a function regular at the origin; and if removable discontinuities be excluded as agreed upon in § 43, it follows that this function must coincide with  $f(z)$  even at the origin. Hence the following theorem :

I. *When a function of a complex argument is regular in the neighborhood of the origin, this point itself excepted, and when, in arbitrarily approaching the origin, it remains in absolute value always less than any assignable limit, then the function is regular at the origin itself provided that removable discontinuities are excluded.*

This may be expressed more briefly but less exactly as follows :  
 "A function of a complex argument is everywhere continuous where it is finite."

But if in the LAURENT'S expansion of the function in the neighborhood of the point  $z = 0$  terms with negative exponents appear, we must determine whether there are an infinite or only a finite number of such terms. In the first case the function behaves at the point  $z = 0$  just as a transcendental integral function at infinity (X, § 44); that is, it approaches arbitrarily near to every value in every neighborhood of this point. For, the sum of the terms with positive exponents becomes arbitrarily small in a sufficiently small neighborhood of the point  $z = 0$  and it is only a question of the terms with negative exponents. In the second case the function is *definitely infinite* at  $z = 0$  in the following sense :

*When a positive number  $M$  however large is given, we can always draw a circle about the point  $z = 0$  with a radius sufficiently small (but  $> 0$ ) so that  $|f(z)| > M$  for all points inside of it. But, if in*

this second case the pole is  $n$ -fold, the limit

$$(1) \quad \lim_{z \rightarrow a} \{(z - a)^n \cdot f(z)\}$$

exists and is finite and different from zero; on the contrary for every positive  $\epsilon$  (however small)

$$\lim_{z \rightarrow a} \{(z - a)^{n+\epsilon} \cdot f(z)\} = 0$$

and  $\lim_{z \rightarrow a} \{(z - a)^{n-\epsilon} \cdot f(z)\}$  is definitely infinite.

By means of the following general definition:

II. *A function is said to be definitely infinite and of the  $\mu$ th order at  $z = a$  when the limit*

$$\lim_{z \rightarrow a} \{(z - a)^\mu f(z)\}$$

*exists and is finite and different from zero — we may state the theorem:*

III. *When a function of a complex argument is regular and single-valued in the neighborhood of a point  $a$ , the point itself excepted, and becomes definitely infinite at  $a$ , it is always infinite at  $a$  of an assignable integral order.*

#### EXAMPLES

1. Expand  $\sqrt{(z - a)(z - b)}$  in powers of  $z$  for the neighborhood of the point  $z = \infty$  (cf. equations 8, 9, § 62).
2. Write the power series which represents the function  $f(z)$  in the neighborhood of the point  $z = \infty$ ,
  - 1st. If the point  $z = \infty$  is an ordinary point for the function;
  - 2d. If the point  $z = \infty$  is a zero of order  $m$ ;
  - 3d. If the point  $z = \infty$  is a pole of order  $m$  for the function.

3. Expand  $\frac{(z-1)(z-2)}{(z-3)(z-4)}$ ,  $\frac{(z-1)^3}{(z-2)(z-3)}$ ,  $\frac{(z-1)}{(z-2)(z-3)^2}$  each in the neighborhood of the point  $z = \infty$ .

4. Expand the functions of the previous example in the neighborhood of the point  $z = 3$ .

§ 49. FOURIER'S Series

From the LAURENT'S expansion valid in a ring between two concentric circles, we can derive an expansion valid in a strip bounded by two parallel lines by making use of §§ 40-42. Let  $r$  and  $R$  be the radii of the two circles between which a function  $f(z)$  satisfies the conditions of LAURENT'S theorem. Without loss of generality, we may suppose  $r < 1$  and  $R > 1$ ; when this is not originally the case it can be obtained by introducing  $cz$  in place of  $z$  where  $c$  is understood to be a suitably chosen real constant. We can then put:

(1) 
$$r = e^{-m_1}, \quad R = e^{m_2}$$

where  $m_1, m_2$  denote positive real constants.

By means of the function

(2) 
$$z = e^t$$

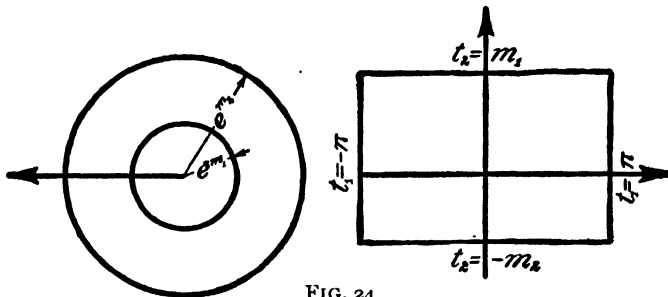

FIG. 24

we can then map a rectangle of the  $t$ -plane upon the circular ring of the  $z$ -plane; we are to think of this ring as having a cut (or

slit) along the negative real axis; and if we put  $t = t_1 + t_2 i$ , the equations of the sides of this rectangle become:

$$(3) \quad t_1 = -\pi, \quad t_1 = +\pi, \quad t_2 = -m_2, \quad t_2 = m_2.$$

Now  $\frac{dz}{dt}$  exists and is finite and different from zero everywhere inside of this rectangle, and therefore  $f(z) = \phi(t)$  is a regular function of  $t$ ; and the LAURENT'S series:

$$f(z) = \sum_{n=-\infty}^{+\infty} c_n z^n,$$

becomes:

$$(4) \quad \phi(t) = \sum_{n=-\infty}^{+\infty} c_n e^{nt_1};$$

or, by introducing the trigonometric instead of the exponential functions:

$$(5) \quad \phi(t) = c_0 + \sum_{n=1}^{\infty} (c_n + c_{-n}) \cos nt + i \sum_{n=1}^{\infty} (c_n - c_{-n}) \sin nt.$$

Conversely, if a function of  $t$  is regular inside of the rectangle, it is transformed by substitution (2) into a function of  $z$  regular inside of the circular ring *opened along the cut*. But in the application of LAURENT'S theorem it is necessary that  $f(z)$  be regular inside of a circular ring *not opened along the cut*. This is the case when, and only when,  $\phi(t)$  is also regular at least in narrow strips beyond the sides of the rectangle parallel to the  $t_2$ -axis and besides when  $\phi(t)$  takes on the same values at pairs of points on these sides which have the same coördinates  $t_2$ . For then the transference of the neighborhood of these two sides to the  $z$ -plane gives two functions of  $z$  regular in the neighborhood of the cut, which coincide along the cut, and are therefore in general identical according to I, § 39. In particular\* this is

\* When a function satisfies the foregoing conditions, we can always look upon it as a piece of a periodic function regular in the parallel strip.

the case when the function  $\phi(t)$  is periodic with period  $2\pi$  and is regular in the entire parallel strip bounded by the straight lines  $t_2 = -m_2$  and  $t_2 = m_1$ . We can therefore state the following theorem:

I. *A periodic function with the period  $2\pi$  which is regular in a strip having a finite breadth along both sides of the real axis, can be developed in a series (a "FOURIER'S Series") of the form:*

$$\phi(t) = a_0 + \sum_{n=1}^{\infty} a_n \cos nt + \sum_{n=1}^{\infty} b_n \sin nt$$

*which is uniformly convergent and admits term by term derivatives of all higher orders.*

The coefficients of this series are determined by introducing  $t$  as variable of integration by means of substitution (2) in the representation of the coefficients of the LAURENT'S series:

$$c_n = \frac{1}{2\pi i} \int f(z) z^{-n-1} dz$$

given in 7, § 47. It is thus found that

$$a_0 = c_0 = \frac{1}{2\pi} \int \phi(t) dt$$

$$(6) \quad a_n = c_n + c_{-n} = \frac{1}{\pi} \int \phi(t) \cos nt dt \quad (n > 0)$$

$$b_n = i(c_n - c_{-n}) = \frac{1}{\pi} \int \phi(t) \sin nt dt,$$

where these integrals are to be taken along any curve which connects a point of the side  $t_1 = -\pi$  with the point lying opposite on the side  $t_1 = \pi$ , the simplest way of connecting them being then to use the real values between  $t = -\pi$  and  $t = +\pi$ .

## § 50. Sums of an Infinite Number of Regular Functions

Let

$$(1) \quad f_1(z), f_2(z), \dots, f_n(z) \dots$$

be an infinite sequence of functions of  $z$  which are all regular inside of a definite domain  $B$  of the  $z$ -plane; let it be assumed further that the series

$$(2) \quad \sum_{n=1}^{\infty} f_n(z)$$

converges at every point of this domain. Its sum is then a complex function (I, § 31) of the real coördinates  $x$  and  $y$  of  $z = x + iy$ . Nothing more can be asserted concerning this sum unless we make additional assumptions concerning the functions  $f_n(z)$ .

But if we assume further that series (2) converges *uniformly* in the entire domain under consideration, we can show as follows that its sum represents a function  $F(z)$  of a complex argument  $z$  regular inside of this domain. If  $\Gamma$  is the bounding curve of this domain, we may integrate series (2) *term by term* along this curve, since according to hypothesis it converges uniformly along  $\Gamma$ . Moreover, this remains true if we divide by  $z - \zeta$  before integrating, providing the denominator does not become indefinitely small at any point on the path of integration; this provision is satisfied when  $\zeta$  is an inner point of the domain (not a point on the boundary). If therefore the sum of series (2) be designated provisionally by  $S(z)$ , we obtain:

$$(3) \quad \frac{1}{2\pi i} \int \left( \frac{S(z)}{z - \zeta} \right) dz = \sum_{n=1}^{\infty} \frac{1}{2\pi i} \int \frac{f_n(z)}{z - \zeta} dz.$$

When the origin belongs to the domain and  $\zeta$  is nearer to it than all of the boundary points, we can expand in increasing powers of  $\zeta$  under the integral sign on the left-hand side of this

equation and integrate term by term as in § 37; we thus see that this left-hand side is in the neighborhood of the origin a regular function,  $F(\zeta)$ , of  $\zeta$ , from which, to be sure, we cannot conclude merely on the basis of this representation by integrals that it is identical with  $S(\zeta)$ . However, the right-hand side is

$$= \sum_{n=1}^{\infty} f_n(\zeta) = S(\zeta)$$

since the separate functions  $f_n$  are by hypothesis regular in  $B$ . Hence  $S(\zeta) = F(\zeta)$ . Since the origin can be put at an arbitrary point of the domain we state the theorem:

I. *The sum of a series of regular functions uniformly convergent in a connected domain is itself a regular function inside of this domain.*

This theorem follows also from XIII, § 38: if the integrals of the separate terms are equal to zero for every closed path of integration inside of  $B$ , the same is true for the integral of the sum on account of the uniform convergence.

A sum of the form (2) may under certain conditions be uniformly convergent in each of several domains not connected among themselves. It will then represent a regular function in each of these domains; but this does not warrant the conclusion that these functions are connected with each other in any manner whatever. As a matter of fact, simple examples\* show that such connection does not necessarily exist.

Moreover, we can draw further conclusions from equation (3). If  $a$  be any point inside of the domain  $S$ , we obtain:

$$(4) \quad F(\zeta) = \frac{1}{2\pi i} \sum_{m=0}^{\infty} (\zeta - a)^m \int_{\Gamma} \frac{F(z)}{(z - a)^{m+1}} dz$$

\* Cf., for example, WEIERSTRASS, *Ges. Werke*, Vol. II, pp. 213, 231. Also FORSYTHE, *Theory of Functions*, p. 138.—S. E. R.

and therefore, according to (8), § 39 :

$$(5) \quad F^{(m)}(a) = \frac{m!}{2\pi i} \int_{\Gamma} \frac{F(z) dz}{(z-a)^{m+1}} = \frac{m!}{2\pi i} \int_{\Gamma} \frac{\sum f_n(z) dz}{(z-a)^{m+1}}.$$

On account of the uniform convergence of the series we may here interchange summation and integration, and thus obtain :

$$F^{(m)}(a) = \sum_{n=1}^{\infty} \frac{m!}{2\pi i} \int_{\Gamma} \frac{f_n(z) dz}{(z-a)^{m+1}} = \sum_{n=1}^{\infty} f_n^{(m)}(a);$$

that is, the following theorem is true :

II. *A series of regular functions, uniformly convergent in a definite domain (not merely along a curve), admits term by term derivatives of all higher orders inside of its domain of convergence.*

From this theorem it then follows further that :

III. *In order to obtain, according to TAYLOR'S theorem, the expansion of a regular function which is defined by a series of regular functions uniformly convergent in the neighborhood of  $z = a$ , we may expand each term of the series in powers of  $z - a$  and then collect all terms having the same powers of  $z - a$ .*

### § 51. MITTAG-LEFFLER'S Theorem

A function  $F(z)$  which is everywhere regular over the finite part of the plane except for a finite number of poles  $a_1, a_2, \dots, a_n$ , can always be represented, according to VI, § 44, in the form :

$$(1) \quad \sum_{\nu=1}^n f_{\nu}(z) + g(z),$$

in which  $g(z)$  represents a transcendental integral function of  $z$  and  $f_{\nu}(z)$  a rational function having no poles other than  $a_{\nu}$ . Closely allied to this is the investigation of the question

whether a function with an infinite number of poles can also be represented in the form of an *infinite series of partial fractions* :

$$(2) \quad \sum_{\nu=1}^{\infty} f_{\nu}(z) + g(z).$$

For this purpose it is necessary and, according to the results of § 50, also sufficient that the series be uniformly convergent. We can see from simple examples that such is not always the case when the poles  $a_{\nu}$  and the functions  $f_{\nu}(z)$ , which determine how  $F(z)$  becomes infinite, are arbitrarily prescribed. The difficulty arising in this way was surmounted by MITTAG-LEFFLER by demonstrating that rational integral functions  $g_{\nu}(z)$  can always be so determined that the series :

$$(3) \quad \sum_{\nu=1}^{\infty} (f_{\nu}(z) - g_{\nu}(z))$$

converges uniformly. We shall not give here a proof for the most general case, but concern ourselves only with a generalization \* sufficing for most applications.

It is to be noticed in the first place that when the function is regular everywhere over the finite part of the plane except at poles, then the set of points  $a_{\nu}$  cannot have a limit point in the finite part of the plane (IV, § 43). Therefore an infinite number of the points  $a_{\nu}$  cannot lie in a finite domain (XVI, § 25); in other words, we must have

$$(4) \quad \lim_{\nu \rightarrow \infty} |a_{\nu}| = \infty.$$

We shall now *first*, suppose that  $|a_{\nu}|$  increases so rapidly as  $\nu$  increases that an integer  $n$  can be determined which has the property that the series :

$$(5) \quad \sum_{\nu=1}^{\infty} |a_{\nu}|^{-n}$$

\* For the general case cf. WEIERSTRASS, *Ges. Werke*, Vol. II, p. 189.

converges. *Second*, let us suppose that the above poles are all of the same order  $\lambda$  and that the decomposition into partial fractions of each of the functions  $f_n$  consists of only one term with coinciding coefficients, all of which may then be taken equal to 1; let then

$$(6) \quad f_\nu(z) = (z - a_\nu)^{-\lambda}.$$

*First*, let  $\lambda = n$ : let any finite domain be given which contains none of the points  $a_\nu$ ; let  $M$  be the largest value which  $|z|$  takes in this domain,  $\mu$  any positive number greater than 1. We then divide the points  $a_\nu$  into two classes according as  $|a_\nu| \leq \mu M$  or  $|a_\nu| > \mu M$ . According to hypothesis there are only a finite number of the points of the first class, say  $k$ ; for every point  $a_\nu$  of the second class and for every point  $z$  of the given domain

$$(7) \quad \left| \frac{a_\nu}{z - a_\nu} \right| = \left| 1 - \frac{z}{a_\nu} \right|^{-1} < \frac{\mu}{\mu - 1},$$

that is, smaller than a finite number independent of  $z$  and  $\nu$ . Let us now subtract the finite sum:

$$(8) \quad \sum_{\nu=1}^k \frac{1}{(z - a_\nu)^n}$$

from the series to be investigated and there will remain the infinite series

$$(9) \quad \sum_{\nu=k+1}^{\infty} \frac{1}{(z - a_\nu)^n}.$$

Each term of this series arises from the corresponding term of series (5) by multiplication by the  $n$ th power of the factor (7), from which it appears that for all terms it is less than one and the same finite limit. Since series (5) according to hypothesis converges absolutely, series (9) also converges absolutely (A. A. § 56); and, in fact, converges uniformly since the above-

mentioned limit is independent of  $z$ . Let us again add the first terms (8) and thus obtain the theorem :

I. *If the series (5) converges, then the series*

$$(10) \quad \sum_{\nu=1}^{\infty} \frac{1}{(z - a_{\nu})^{\lambda}}$$

*converges absolutely and uniformly in every domain which lies in the finite part of the plane and which contains none of the points  $a_{\nu}$ .*

*Second:* if  $\lambda > n$ , then the terms of the series :

$$(11) \quad \sum_{\nu=1}^{\infty} \frac{1}{(z - a_{\nu})^{\lambda}}$$

arise from the corresponding terms of series (10) by multiplication by the factors :

$$(12) \quad (z - a_{\nu})^{-\lambda+n}$$

If small circles of radius  $\rho$  be described about the points  $a_{\nu}$  and if  $z$  be limited to a domain containing none of these circles, then each of the factors (12) for all points  $z$  of this domain is in absolute value less than the finite number

$$\rho^{-\lambda+n}$$

independent of  $z$  and  $\nu$ . But since series (10) converges absolutely, it follows that :

II. *If series (5) converges, then for  $\lambda > n$  series (11) also converges uniformly and absolutely in every domain which lies in the finite part of the plane and which contains none of the points  $a_{\nu}$ .*

But *third:* if  $\lambda < n$ ,  $-\lambda + n$  is positive and we cannot draw the conclusion as above ; for then  $|z - a_{\nu}|^{-\lambda+n}$  is not smaller but is larger than  $\rho^{-\lambda+n}$ . But in this case we may proceed as follows : By integrating term by term between two arbitrary

limits  $z_0, z$  along an arbitrary path inside the domain of uniform convergence—which is allowable according to VIII, § 28—we obtain the following uniformly convergent series from series (10):

$$(13) \quad -(n-1) \int_{z_0}^z \left\{ \sum_{\nu=1}^{\infty} \frac{1}{(z-a_{\nu})^n} \right\} dz = \sum_{\nu=1}^{\infty} \left\{ \frac{1}{(z-a_{\nu})^{n-1}} - \frac{1}{(z_0-a_{\nu})^{n-1}} \right\}.$$

In this series each term becomes infinite for  $z = a_{\nu}$  as  $\frac{1}{(z-a_{\nu})^{n-1}}$  does; the problem is thus solved for  $\lambda = n - 1$ . We can apply the same conclusion to this series when  $n > 2$ , and so continue until the exponents in the denominator are depressed to  $\lambda$ . We state this result explicitly only under the simple supposition that the point  $z = 0$  is not one of the points  $a_{\nu}$ ; we may then put  $z_0 = 0$  and thus obtain the following theorem:

III. *If series (5) converges and if  $\lambda < n$ , then the series*

$$(14) \quad \sum_{\nu=1}^{\infty} \left\{ \frac{1}{(z-a_{\nu})^{\lambda}} - \frac{1}{(-a_{\nu})^{\lambda}} \left[ 1 + \frac{\lambda}{1} \cdot \frac{z}{a_{\nu}} + \frac{\lambda(\lambda+1)}{1 \cdot 2} \cdot \frac{z^2}{a_{\nu}^2} + \dots + \binom{n-2}{\lambda-1} \frac{z^{n-\lambda-1}}{a_{\nu}^{n-\lambda-1}} \right] \right\}$$

*converges uniformly and absolutely in every domain which lies in the finite part of the plane and which contains none of the points  $a_{\nu}$  in its interior, provided that the whole expression under the summation sign be considered as one term of the series and is not separated.*

Moreover, the law of formation for series (14) can be stated thus: To  $(z-a_{\nu})^{-\lambda}$  must be added a rational integral function of  $z$  such that every term of the series is zero of order  $n - \lambda$  at the point  $z = 0$ .

It therefore follows from the general theorem of § 50 that each of the series (10), (11), (14) represents a function of  $z$

regular in the domain of its uniform convergence. Its behavior at one of the points  $a_\nu$  may be obtained by taking out of the series that term which is relevant at this point; the remaining part of the series also converges uniformly in the neighborhood of  $a_\nu$ , it is then regular there, and the function has therefore a pole at  $z = a_\nu$  of the kind prescribed.

IV. *The most general function, which has poles of the prescribed kind at all these points, is obtained by adding the most general transcendental integral function to the sum of the series.*

If it is a question of developing a *preassigned* function in a series of partial fractions of the kind here considered, the determination of this complementary integral function presents a certain difficulty which can be disposed of in some cases by the following procedure due to CAUCHY.

Let us suppose an infinite sequence of closed lines  $C_\nu$  ( $\nu = 1, 2, 3, \dots$ ) having the property that each time  $C_{\nu-1}$  lies entirely inside of  $C_\nu$  and the point  $a_\nu$  lies inside of  $C_\nu$  but outside of  $C_{\nu-1}$ . If, therefore, small circles are drawn about the points  $a_1, a_2, \dots, a_k$ , Theorem II, of § 45 is applicable to the domain between  $C_k$  and these circles; we obtain accordingly:

$$(15) \quad f(\zeta) = \sum_{\nu=1}^k f_\nu(\zeta) + \frac{1}{2\pi i} \int_{C_k} \frac{f(z) dz}{z - \zeta}.$$

The problem is then solved if by any suitable choice of the curves  $C_k$  we succeed in determining the value of the limit to which the integral standing on the right converges as  $k \doteq \infty$ .\* In the application to individual cases this method may be modified in various ways; for example, inside each of the curves  $C_\nu$  we may take two poles more than in the preceding instead of one.

\* For further investigations cf. E. PICARD, *Traité d'analyse*, Vol. II (Paris, 1893), chap. VI, No. 5 *et seq.*

### § 52. Decomposition of Singly Periodic Functions into Partial Fractions

We return now to the investigation of singly periodic functions discontinued at § 42 having in the meantime obtained additional methods. The theorem of the last paragraph enables us to form a priori such functions.

By introducing  $cz$  instead of  $z$  as the argument, 1 can be made the primitive period for the function. It is required to form a function having this period and having a pole at  $z = 0$ ; it must then necessarily have poles at all those points which arise from the point  $z = 0$  by the addition and subtraction of periods; that is, in the points:

$$z = 1, 2, 3, \dots, \infty, \quad z = -1, -2, -3, \dots, \infty.$$

Let us form now a function which has these points (and no others) for poles; and, in order to apply the theorems of the previous paragraph, we inquire whether there is any value of  $n$  for which the series

$$\sum_{\nu=1}^{\infty} \frac{1}{\nu^n}$$

converges. The reader will readily recall that this series is not convergent for  $n = 1$ , but does converge for  $n = 2$  (A. A. § 55). There is then according to (10), § 51, a function:

$$(1) \quad f_1(z) = \sum_{\nu=-\infty}^{+\infty} \frac{1}{(z - \nu)^2}$$

which has all of the points named above for a twofold pole. In forming from it, according to (14), § 51, another function for which these points are only simple poles, we observe that the hypothesis made there does not apply here, viz. that the point  $z = 0$  is not to be among the points  $a_\nu$ . Therefore, in applying

that theorem here, we must do so not to  $f_1(z)$  but to  $f_1(z) - z^{-2}$ ; the following function is thus obtained :

$$(2) \quad f_2(z) = \frac{1}{z} + \sum_{\nu=-\infty}^{+\infty} \left( \frac{1}{z-\nu} + \frac{1}{\nu} \right).$$

(The accent on the summation sign signifies here and in what follows that the value  $\nu = 0$  is omitted from the values over which the summation is taken.)

We can now show that these two functions constructed in this way really have 1 for a period. That the first function has the period 1 follows directly from the representation (1). For, if we replace  $z$  in this representation by  $z + 1$ , we obtain in full the following :

$$\sum_{\nu=1}^{\infty} \frac{1}{(z+1-\nu)^2} + \frac{1}{(z+1)^2} + \sum_{\nu=-1}^{-\infty} \frac{1}{(z+1-\nu)^2}.$$

Replacing now the summation letter  $\nu$  in this expression by  $\mu + 1$ , we obtain :

$$\sum_{\mu=0}^{\infty} \frac{1}{(z-\mu)^2} + \frac{1}{(z+1)^2} + \sum_{\mu=-2}^{-\infty} \frac{1}{(z-\mu)^2};$$

and this is the original series, except that the term  $z^{-2}$  is combined with the first sum and the term  $(z+1)^{-2}$  is omitted from the second sum. It therefore follows that :

$$(3) \quad f_1(z+1) = f_1(z).$$

But the same conclusion for the function  $f_2(z)$  cannot be drawn since the parenthesis in (2) is not to be removed : however, since

$$(4) \quad f_1(z) = -\frac{df_2(z)}{dz}$$

it follows from equation (3) by integration that

$$(5) \quad f_2(z+1) = f_2(z) + C.$$

In this equation  $C$  signifies a constant of integration which can be determined whenever we evaluate both sides of the equation for some particular value of  $z$ . We could also use a value of  $z$  for which the two sides become infinite; for this purpose we compare the first terms of the expansions valid for the neighborhood of this value of  $z$ . Thus, for example, we obtain for the neighborhood of  $z = 0$ :

$$\frac{1}{z-\nu} + \frac{1}{\nu} = -\frac{z}{\nu^2} + (z^2),$$

and therefore:

$$(6) \quad f_2(z) = \frac{1}{z} - z \sum' \frac{1}{\nu^2} + (z^2);$$

also:

$$\frac{1}{z+1} = 1 - z + (z^2),$$

$$\frac{1}{z+1-\nu} + 1 = \frac{1}{z} + 1,$$

$$\frac{1}{z+1-\nu} + \frac{1}{\nu} = \frac{1}{1-\nu} + \frac{1}{\nu} - \frac{z}{(1-\nu)^2} + (z^2), \quad (\nu \neq 0, 1),$$

and accordingly

$$(7) \quad f_2(z+1) = \frac{1}{z} + 2 + \sum_{\nu=2}^{\infty} \frac{1}{(1-\nu)\nu} + \sum_{\nu=-1}^{-\infty} \frac{1}{(1-\nu)\nu} + (z).$$

Comparison of the coefficients of  $z^0$  gives

$$C = 2 + \sum_{\nu=2}^{\infty} \frac{1}{\nu(1-\nu)} + \sum_{\nu=-1}^{-\infty} \frac{1}{\nu(1-\nu)}.$$

If  $\nu$  be replaced by  $1-\mu$  in the second summation, we obtain:

$$\sum_{\mu=2}^{\infty} \frac{1}{\mu(1-\mu)}.$$

The two summations are therefore equal to each other, and in fact each is equal to  $-1$ ; for,

$$\sum_{\mu=2}^m \frac{1}{\mu(\mu-1)} = \left(1 - \frac{1}{2}\right) + \left(\frac{1}{2} - \frac{1}{3}\right) + \dots + \left(\frac{1}{m-1} - \frac{1}{m}\right) = 1 - \frac{1}{m}.$$

Accordingly  $C = 0$ ; that is:

*I. Not only  $f_1(z)$  but also  $f_2(z)$  is a periodic function of  $z$  with the period  $1$ .*

We inquire next about the relation of these functions to the periodic functions investigated in §§ 40-42; to answer this question, we make use of the method due to CAUCHY mentioned at the end of the previous paragraph. We observe that in equation (2) the terms may be arranged in pairs of values of  $\nu$  that are equal but opposite in sign; accordingly then

$$(8) \quad f_2(z) = \frac{1}{z} + \sum_{\nu=1}^{\infty} \left( \frac{1}{z-\nu} + \frac{1}{z+\nu} \right)$$

(where as before the parenthesis must not be removed). If the cotangent function is now defined as for real variables by the equation:

$$(9) \quad \cot z = \frac{\cos z}{\sin z},$$

it follows from the results of § 41 that the function  $\pi \cot(\pi z)$  has the same (simple) poles and the same residues as  $f_2(z)$ . If we then take as the line  $C_k$  a rectangle whose sides have the equations:

$$x = \pm \frac{2k+1}{2} \text{ and } y = \pm \eta,$$

the poles:  $0, \pm 1, \pm 2, \dots, \pm k$

lie inside of it; we therefore obtain:

$$(10) \quad \pi \cot(\pi \zeta) = \frac{1}{\zeta} + \sum_{\nu=1}^k \left( \frac{1}{\zeta-\nu} + \frac{1}{\zeta+\nu} \right) + \frac{1}{2\pi i} \int_{C_k} \frac{\pi \cot(\pi z)}{z-\zeta} dz.$$

But:

$$(11) \quad \int_{C_k} \frac{\pi \cot(\pi z)}{z} dz = 0,$$

since the cotangent is an odd\* function and the line  $C_k$  is symmetrical about the point  $z = 0$ ; we can then replace the integral appearing in (10) by

$$\pi \zeta \int_{C_k} \frac{\cot(\pi z)}{z(z - \zeta)} dz.$$

To evaluate this integral let us start from the equation:

$$(12) \quad |\cot(\pi z)|^2 = \frac{e^{2\pi y} + e^{-2\pi y} + 2 \cos 2\pi x}{e^{2\pi y} + e^{-2\pi y} - 2 \cos 2\pi x};$$

it follows from this that, upon the two vertical sides of the rectangle:

$$(13) \quad |\cot(\pi z)| = \left| \frac{e^{\pi y} - e^{-\pi y}}{e^{\pi y} + e^{-\pi y}} \right| \leq 1,$$

and upon the two horizontal sides:

$$(14) \quad |\cot(\pi z)| \leq \left| \frac{e^{\pi \eta} + e^{-\pi \eta}}{e^{\pi \eta} - e^{-\pi \eta}} \right|; \text{ that is, } \leq \left| \frac{1 + e^{-2\pi \eta}}{1 - e^{-2\pi \eta}} \right|.$$

Therefore, along all of the lines  $C_k$ ,  $|\cot(\pi z)| < M$ , where  $M$  denotes a number independent of  $k$ . If we designate the shortest distances of the points  $0$  and  $\zeta$  from  $C_k$  by  $r_k$  and  $\rho_k$ , and the length of  $C_k$  by  $S_k$ , it then follows that:

$$(15) \quad \left| \int_{C_k} \frac{\cot(\pi z)}{z(z - \zeta)} dz \right| \leq \frac{M \cdot S_k}{r_k \cdot \rho_k}.$$

\* An odd function may be defined as one for which  $f(x) = -f(-x)$  and an even function one for which  $f(x) = +f(-x)$ . Particular cases are those for which the odd function contains only odd powers of the variable and an even one only even powers, as  $\sin x$  and  $\cos x$ . — S. E. R.

As  $\eta$  increases,  $M$  decreases; we are thus at liberty to allow  $\eta$  to increase to infinity with  $k$ . It follows, therefore, that  $S_k = 8 r_k$  and  $\rho_k$  (for a given  $\zeta$ ) increases to infinity with  $k$ . Then the limit of the integral as  $k \doteq \infty$  is equal to 0 and it follows from (10) that:

$$(16) \quad f_2(z) = \pi \cot \pi z$$

(cf. A. A. (11), § 84) and from this it follows further that:

$$(17) \quad f_1(z) = \frac{\pi^2}{\sin^2 \pi z}.$$

II. *The functions represented by these partial fractions are then rational functions of  $\cos \pi z$  and  $\sin \pi z$ .*

If in equations (16) and (2),  $a$  and  $a + z$  are substituted successively for  $z$  and the results subtracted, the following formula is obtained:

$$(18) \quad \pi [\cot \pi (a + z) - \cot (\pi a)] = \sum_{\nu=-\infty}^{+\infty} \left( \frac{1}{z + a - \nu} - \frac{1}{a - \nu} \right).$$

### § 53. General Theorems concerning Singly Periodic Functions

We derive here another general theorem concerning singly periodic functions for which Theorem II of the previous paragraph is a special case. Let us again suppose that 1 is the primitive period, since it may be obtained by multiplying the argument by a constant, and that then a strip bounded by the lines  $x = -\frac{1}{2}$  and  $x = +\frac{1}{2}$  can be used as the period strip; and we study singly periodic functions  $f(z)$ , which have the following properties:

1.  $f(z)$  is everywhere regular in the finite part of the plane except at poles.

2. When  $z = x + iy$  passes to infinity where  $y$  is positive without going outside of the period strip, at least one of the two limits  $\lim_{y \rightarrow +\infty} f(z)$  or  $\lim_{y \rightarrow +\infty} \left( \frac{1}{f(z)} \right)$  exists.

3. When  $z = x + iy$  goes to infinity in the same manner where  $y$  is negative, we have analogous results; however, it is not supposed that  $\lim_{y \rightarrow -\infty} f(z) = \lim_{y \rightarrow +\infty} f(z)$ .

By means of the substitution:

$$(1) \quad \zeta = e^{2\pi iz}$$

we can map (cf. §§ 42 and 49) the parallel strip of the  $z$ -plane conformally on the  $\zeta$ -sphere cut along a meridian (apart from the neighborhoods of the points  $\zeta = 0$  and  $\zeta = \infty$ ). In this way the function  $f(z)$  is transformed into a function  $\phi(\zeta)$  which has the following properties:

1. Since  $f(z)$  is periodic,  $\phi(\zeta)$  is single-valued; its values (as also those of its derivative) on one side of the cut pass continuously into the values on the other side of the cut.

2. Since  $f(z)$  is regular everywhere in the finite part of the plane except at poles,  $\phi(\zeta)$  is regular, with the exception of poles, over the whole sphere except at  $\zeta = 0$  and  $\zeta = \infty$ .

3. If  $\zeta$  is allowed to converge to zero along any path, then the corresponding  $z$ -path runs to infinity where  $y$  is positive; and if the  $\zeta$ -path does not encircle the point  $\zeta = 0$  infinitely often, then the  $z$ -path first crosses a finite number of period strips and finally remains within one of them. It follows therefore from hypothesis (2) that at least one of the two limits

$$(2) \quad \lim_{\zeta \rightarrow 0} \phi(\zeta), \quad \lim_{\zeta \rightarrow \infty} \frac{1}{\phi(\zeta)}$$

exists (for every such kind of approach of  $\zeta$  to zero), and that then (I, III, § 48)  $\phi(\zeta)$  is either regular at  $\zeta = 0$  or has a pole there. But even when the  $\zeta$ -path does encircle the point  $\zeta = 0$  an infinite number of times, the  $z$ -path crosses an infinite number of period strips and we obtain the same result; for, since  $f(z)$  is supposed to be periodic, we can transfer to the first strip all parts of the  $z$ -path which lie in strips other than the first one.

4. In an analogous manner, it follows from hypothesis (3) that  $\phi(\zeta)$  is either regular at infinity or has a pole there.

Thus  $\phi(\zeta)$  is regular over the whole sphere except at poles, and is therefore, according to VI, § 44, a rational function of  $\zeta$ ; that is, we have the theorem :

I. *Every periodic function which satisfies the hypotheses (1)–(3), is a rational function of the exponential function  $e^{2\pi iz}$ .*

A series of further theorems follow from this one. Let  $f(z)$  be such a function; with the aid of equation (11), § 40, we can then eliminate the exponential functions from the expressions for  $f(z_1)$ ,  $f(z_2)$ ,  $f(z_1 + z_2)$  formed according to Theorem I, and obtain an algebraic equation between  $f(z_1 + z_2)$ ,  $f(z_1)$ ,  $f(z_2)$ , whose coefficients are independent of  $z_1$  and  $z_2$ . Such an equation is called an algebraic addition theorem; hence the theorem:

II. *Every function of the kind described has an algebraic addition theorem.*

Further, if we had two such functions, we could eliminate the exponential function and find that:

III. *Between pairs of such functions there is an algebraic equation with coefficients independent of  $z$ .*

In particular this is true of such a function and its first derivative; accordingly, we have:

IV. *Every such function satisfies an algebraic differential equation of the first order in which the independent variable does not appear explicitly;*

or otherwise expressed:

IV a. *Every such function is the inverse of the integral of an algebraic function.*

The following equations, for real values of  $u$  and  $z$ , are examples of this theorem :

$$(3) \quad u = \int_0^z \frac{dz}{1+z^2}, \quad z = \tan u;$$

$$(4) \quad u = \int_0^z \frac{dz}{\sqrt{1-z^2}}, \quad z = \sin u.$$

Theorem III introduces us to a class of algebraic equations between two variables  $z$  and  $s$ , which are satisfied identically by putting *single-valued* singly periodic functions of an auxiliary variable  $u$  (a "uniformizing\* variable" one may say) equal to  $s$  and  $z$ ; as, for example, in the equation :

$$(5) \quad s^2 + z^2 - 1 = 0$$

where

$$(6) \quad s = \sin u, \quad z = \cos u.$$

But we recall that these equations (on account of Theorem I) are none other than those which are satisfied identically by putting *rational* functions of an auxiliary variable equal to  $z$  and  $s$ , for example, in equation (5) :

$$(7) \quad s = \frac{2t}{1+t^2}; \quad z = \frac{1-t^2}{1+t^2}.$$

We will not introduce here the proof that this property does not belong to every algebraic equation between two variables. On the contrary, the investigation of single-valued functions of a complex variable is discontinued at this point and the discussion of many-valued functions is taken up in the next chapter.

\* Cf. WHITTAKER, *Modern Analysis*, p. 338. — S. E. R.

## MISCELLANEOUS EXAMPLES

1. Determine all the roots of the equations:

(a)  $\sin z = 2$ , (b)  $\cos z = -5i$ .

2. Show that the functions  $\sin z$ ,  $\cos z$ , have no other zeros or no other periods than those of the real functions  $\sin x$ ,  $\cos x$ .

3. If  $C(x) = 1 - \frac{x^2}{2!} + \frac{x^4}{4!} - \dots$  and  $S(x) = x - \frac{x^3}{3!} + \frac{x^5}{5!} - \dots$

show that  $C(x+y) = C(x) \cdot C(y) - S(x) \cdot S(y)$

and  $S(x+y) = S(x) \cdot C(y) + C(x) \cdot S(y)$ .

4. Prove that a function which has a derivative that vanishes at every point of a finite region is constant in that region.

5. How is a definite integral defined for a complex variable? From the definition, show that

$$\left| \int f(z) dz \right| \leq ML$$

where  $L$  is the length of the path of integration and  $M$  is the maximum of  $|f(z)|$  on this path.

6. State and prove CAUCHY'S theorem on residues.

7. Calculate  $\int_{-\infty}^{+\infty} \frac{x^2 - x + 2}{(x^2 + 1)(x^2 + 9)} dx$ ;

also  $\int_{-\infty}^{+\infty} \frac{x^2 - 5}{(x^2 + 1)(x^2 + 9)} dx$ .

Cf. also Ex. 35 of this list and the reference given there.

7 a. An integral appearing in the theory of probability is the following one:

$$\int_0^{\infty} e^{-x^2} dx.$$

The following method of evaluation (cf. PICARD, *Traité d'analyse*, Vol. 1, p. 104) is particularly simple and elegant. Let us begin with the real double integral :

$$\iint e^{-x^2-y^2} dS$$

taken over the first quadrant. This integral converges since the following limit exists :

$$\lim_{x \rightarrow \infty, y \rightarrow \infty} r^k e^{-r^2-y^2}, \quad r^2 = x^2 + y^2, \quad k > 2.$$

We now obtain the desired formula by putting the double integral in the form :

$$\int_0^{\infty} \int_0^{\infty} e^{-x^2-y^2} dx dy = \left( \int_0^{\infty} e^{-y^2} dy \right) \left( \int_0^{\infty} e^{-x^2} dx \right) = \left( \int_0^{\infty} e^{-x^2} dx \right)^2$$

and evaluate it by means of polar coördinates in the form :

$$\int_0^{\infty} \int_0^{\frac{\pi}{2}} r e^{-r^2} d\theta dr = \frac{\pi}{4}.$$

Thus 
$$\int_0^{\infty} e^{-x^2} dx = \frac{\sqrt{\pi}}{2}.$$

8. By taking  $\int e^{-z^2} dz$  along the rectangle  $y = 0, y = \alpha, x = \pm \beta$ , prove that

$$\int_{-\infty}^{+\infty} e^{-x^2} \cdot \cos 2 \alpha x \cdot dx = \sqrt{\pi} \cdot e^{-\alpha^2}$$

given that 
$$\int_{-\infty}^{+\infty} e^{-x^2} \cdot dx = \sqrt{\pi}.$$

9. What are the poles of the function  $\frac{e^{az}}{1 + e^z}$ ?

10. Prove that any two simply connected plane regions can be mapped conformally on each other, stating accurately the theorems used in the proof.

11. If the functions  $f_i(z)$  can be developed about the point  $z = 0$  as follows :

$$f_1(z) = a_0 + a_1z + a_2z^2 + \dots$$

$$f_2(z) = b_0 + b_1z + b_2z^2 + \dots$$

$$f_3(z) = c_0 + c_1z + c_2z^2 + \dots$$

and if the series :

$$F(z) = f_1(z) + f_2(z) + f_3(z) + \dots$$

is uniformly convergent throughout the neighborhood of the point  $z = 0$ , prove that the series :

$$k_0 = a_0 + b_0 + c_0 + \dots$$

$$k_1 = a_1 + b_1 + c_1 + \dots$$

$$k_2 = a_2 + b_2 + c_2 + \dots$$

are convergent and that the development of  $F(z)$  is

$$F(z) = k_0 + k_1z + k_2z^2 + \dots$$

12. Establish the relation between the convergence of a series of complex terms and the convergence of the series of their absolute values.

13. If a polynomial in  $(x, y)$  with real coefficients satisfies LAPLACE'S equation, prove that it is the real part of a polynomial in  $z = x + iy$ .

14. Prove that a necessary and sufficient condition that a homogeneous polynomial of the  $n$ th degree in  $(x, y)$  satisfies LAPLACE'S equation is, that the equation formed by setting the polynomial equal to zero represents  $n$  real straight lines making angles  $\frac{\pi}{n}$  with one another.

15. Define the exponential function for complex values of the argument, pointing out the chief characteristics which must be preserved in order that the new function may be regarded as a generalization of the original one.

16. Prove that a rational function can be represented by means of partial fractions.

17. What functional properties characterize completely the rational functions? (Cf. also Ex. 6 at the end of § 68.)

18. Discuss the theory of the system of partial differential equations

$$\frac{\partial \phi}{\partial x} = P(x, y)$$

$$\frac{\partial \phi}{\partial y} = Q(x, y)$$

where  $P$  and  $Q$  are given functions of  $x$  and  $y$ , and show how this system of equations is connected with the theory of the line integral

$$\int (Pdx + Qdy).$$

What connection has this with functions of a complex variable?

19. What is the condition that a function  $f(z)$ , having the period  $\omega$ , be expressible as a rational function  $e^{\frac{2\pi i}{\omega} z}$ ?

20. Define the terms: Singular Point; Pole; Order of a Pole; Critical Point; Order of a Critical Point.

State and prove the geometrical property of a critical point of the  $n$ th order.

21. Define GREEN'S theorem for two dimensions and explain its physical meaning. (Cf. HARKNESS AND MORLEY, *Introduction*, etc., p. 322.)

Show how GREEN'S theorem may be applied to a simply connected region to effect the conformal mapping of the region on the interior of a circle.

22. Give a direct proof that in the transformation by means of  $w = e^z$  angles are preserved.

23. Suppose a function holomorphic in a region  $A$  with the exception of poles at  $c_1, c_2, \dots, c_p$  of order, respectively,  $n_1, n_2, \dots, n_p$ . Discuss the general type of the function which is holomorphic everywhere in the region  $A$ ; that is, find the function for which

the discontinuities of the original function are removed. (Cf. Exs. 8, 9, at the end of § 47.)

**24.** Prove that for sufficiently large values of  $|z|$ , the absolute value of the last term in

$$a_r z^r + a_{r+1} z^{r+1} + \dots + a_n z^n$$

where  $r$  is an integer which is less than  $n$  and greater than 0, is greater than the sum of the absolute values of the remaining terms.

**25.** Prove that the sum of two functions, both continuous at  $a$ , is continuous at  $a$ . Prove the same for their product, and also for their quotient if the denominator is not zero.

**26.** Calculate the residues of the function  $\frac{1}{(1+z^2)^{n+1}}$ , and then show that

$$\int_{-\infty}^{+\infty} \frac{dx}{(1+x^2)^{n+1}} = \frac{1 \cdot 3 \cdot 5 \cdots (2n-1)}{2 \cdot 4 \cdot 6 \cdots 2n} \cdot \pi;$$

and derive from the latter result the value of the integrals

$$\int_{-\infty}^{+\infty} \frac{dx}{[(x-\alpha)^2 + \beta^2]^{n+1}} \quad \text{and} \quad \int_{-\infty}^{+\infty} \frac{dx}{(Ax^2 + Bx + C)^{n+1}}.$$

HINT. —  $f^n(a) = \frac{n!}{2\pi i} \int \frac{f(z) \cdot dz}{(z-a)^{n+1}}$ , where  $f(z)$  is regular throughout the region bounded by the curve along which the integral is taken. In this case  $a$  is  $i$  and  $f(z)$  is  $\frac{1}{(z+i)^{n+1}}$ .

**27.** If  $f(z)$  is single-valued and regular in a region  $S$ , show that  $1/f(z)$  is in general regular in this region. Discuss the singularities of the latter function.

**28.** When is a function  $f(z)$  said

(a) to be “analytic about” or “regular at” \* the point  $z = \infty$ ,

(b) to have a root,

(c) to have a pole,

(d) to have an essential

} at the point  $z = \infty$ ?

singular point

\* Cf. BÔCHER, *Bull. Am. Math. Soc.*, Vol. III, p. 89. — S. E. R.

29. If the functions  $f(z)$ ,  $\phi(z)$  each have an essential singular point at the point  $z = \infty$ , what can be said about the function

$$F(z) = \frac{f(z)}{\phi(z)} ?$$

Give the reasons for your answer.

30. If  $F(z)$  and  $G(z)$  are rational integral functions of  $z$  of degree  $n$  and  $p$  respectively, show directly that there is one and only one pair of rational integral functions of  $z$  :

$$Q(z) = q_0 z^{n-p} + q_1 z^{n-p-1} + \cdots + q_{n-p},$$

$$G_1(z) = r_0 z^{p-1} + r_1 z^{p-2} + \cdots + r_{p-1}$$

which satisfies the identity

$$F \equiv QG + G_1.$$

Develop the right side in powers of  $z$  and equate coefficients of like powers on both sides of the equation. This gives  $n + 1$  linear equations for the determination of the  $n + 1$  coefficients :

$$q_0, \cdots, q_{n-p}, r_0, \cdots, r_{p-1}.$$

31. A single-valued function  $w = f(z)$  of  $z$  is called *periodic* when there is a constant  $p \neq 0$  such that  $f(z + p) = f(z)$  for every value of  $z$ . Show directly from the fundamental theorem of algebra that *every periodic single-valued monogenic function of  $z$  is transcendental*.

Suppose  $w$  satisfies an irreducible algebraic equation  $F(z, w) = 0$ , that is, an equation which cannot be decomposed into the product of several factors of a similar kind but of lower degree in the variables. Let this equation be of the  $m$ th degree in  $z$  and of the  $n$ th degree in  $w$  and let us consider the equation  $F(z, w_0) = 0$ . This equation cannot hold for every value of  $z$  since the function  $F(z, w)$  is not divisible by  $w - w_0$ . Thus at most can  $m$  values of  $z$  belong to the value  $w_0$  of  $f(z)$ . But this contradicts the condition that the equation  $w_0 = f(z)$  has innumerable roots, namely, all of the form  $z = z_0 + kp$  where  $k$  is any arbitrary integer. Thus  $f(z)$  cannot be an algebraic function of  $z$ .

32. Interpret geometrically the following limit :

$$\lim_{h \rightarrow 0} \left[ \frac{f(z_0 + h) - f(z_0)}{h^\mu} \right] = \text{const.} \neq 0,$$

assuming for the function  $w = u + iv = f(z)$  that  $u$  and  $v$  are continuous and have continuous first derivatives and that  $\mu$  is real and positive.

HINT. — Take two points  $z_1 = z_0 + h$  and  $z_0$  on a curve in the  $z$ -plane and two points  $w_1$  and  $w_0$  in the  $w$ -plane corresponding to them by the function  $w = f(z)$ . Show that a geometrical interpretation of the above limit is, that the angle between any two curves in the  $z$ -plane has the ratio  $1 : \mu$  to its corresponding angle in the  $w$ -plane.

33. Compute  $\int_C \frac{-y dx + x dy}{x^2 + y^2}$  and  $\int_C \frac{x dx + y dy}{x^2 + y^2}$

in the parameter form for the ellipse  $C$  about the origin,  $x = a \cos t$ ,  $y = b \sin t$ .

34. Show by the CAUCHY process that

$$\int_0^{2\pi} \cos^n t dt = \begin{cases} 0 & \text{if } n \text{ is odd,} \\ \frac{1 \cdot 3 \cdot 5 \cdots n - 1}{2 \cdot 4 \cdot 6 \cdots n} 2\pi & \text{if } n \text{ is even.} \end{cases}$$

HINT. — Put  $\cos t = \frac{e^{it} + e^{-it}}{2} = \frac{w + \frac{1}{w}}{2}$  where  $w = e^{it}$  and evaluate the integral along the unit circle in the  $w$ -plane.

35. Show by evaluation along suitable contours that

$$\int_{-\infty}^{+\infty} \frac{e^{mx}}{1 + x^2} dx = \pi e^{-m},$$

$$\int_{-\infty}^{+\infty} \frac{\cos mx}{1 + x^2} dx = \frac{\pi}{2} e^{-m}, \text{ and}$$

$$\int_0^{-\infty} \frac{\sin x}{x} dx = \frac{\pi}{2}.$$

Cf. GOURSAT, *Cours d'analyse*, Vol. II, p. 112.

## CHAPTER V

### MANY-VALUED ANALYTIC FUNCTIONS OF A COMPLEX VARIABLE

#### § 54. Preliminary Investigation of the Change of Amplitude of a Continuously Changing Complex Quantity

Before studying many-valued functions of a complex variable, some attention must be given, as suggested in § 4, to an expression which has several values corresponding to one value of the argument but which is not a regular function of this argument. We recall from § 4 that every complex number

$$(1) \quad z = x + iy = r(\cos \phi + i \sin \phi)$$

has infinitely many values of the amplitude  $\phi$ , all of which are obtained from any one of them by the addition or subtraction of arbitrary, integral multiples of  $2\pi$ . From these infinitely many values, the principal value of the amplitude is now defined as follows:

I. *The principal value\* of the amplitude of a complex number is that one of its values which satisfies the conditions*

$$(2) \quad -\pi < \phi \leq \pi.$$

It is essential here to make clear that this principal value of the amplitude is in general, but not without exception, a continuous function of the real variables  $x$  and  $y$ . Thus let  $(x_1, y_1)$  be a point,  $\phi_1$  the principal value of its amplitude, and let

\*The principal value of the amplitude is indicated by a capital, as  $\text{Am}z$ .  
—S. E. R.

$(x_1 + \xi, y_1 + \eta)$  be a neighboring point. If we now put

$$(3) \quad \frac{x_1 + \xi + i(y_1 + \eta)}{x_1 + iy_1} = \frac{r_1 + \rho}{r_1} (\cos \theta + i \sin \theta),$$

and if  $\theta$  is understood to be the principal value of the amplitude of the expression on the left, then as  $\xi$  and  $\eta$  vanish  $\theta$  also vanishes. One value of the amplitude of  $x_1 + \xi + i(y_1 + \eta)$  is then  $\phi_2 = \phi_1 + \theta$ . If  $\phi_1$  is not  $= \pi$ , then  $\theta$  can be taken so small that  $\phi_2$  also satisfies the inequality (2);  $\phi_2$  is therefore a principal value, and the difference of the principal values  $\phi_2$  and  $\phi_1$  is only indefinitely small; in other words:

II. *The principal value of the amplitude of a complex number is a continuous function of its components in every domain of the plane which is not intersected by the half-axis of negative real numbers.*

But if  $\phi_1 = \pi$ , then  $\phi_1 + \theta$  satisfies the inequality (2) for indefinitely small negative values of  $\theta$ , and is therefore a principal value; but for  $\theta$  positive and indefinitely small,  $\phi_1 + \theta$  is not a principal value, but  $\phi_1 + \theta - 2\pi = -\pi + \theta$  is such a value. Theorem II is therefore extended by the addition of the following corollary:

III. *The continuity of the principal value of the amplitude is interrupted along the half-axis of negative real numbers in so far as its value at a point of this half-axis coincides with the limit of its values at points adjacent to it in the "upper" half-plane, but is greater by  $2\pi$  than the limit of the values which it has at points adjacent to it in the "lower" half-plane.*

However, these latter values follow continuously from those values of the amplitude of the negative real numbers which  $= -\pi$ , and consequently are less by  $2\pi$  than the principal value  $+\pi$ .

What was said about the principal value in Theorems II and III is at once applicable to the other values of the amplitude. Naming that value which is greater than the principal value by  $2k\pi$ , the value of order  $k$  (the principal value being thus of order zero), we have the following theorem :

IV. *The value of order  $k$  of the amplitude of a complex number is a continuous function of its components outside of the half-axis of negative real numbers ; but its values along this axis in the lower half-plane follow continuously the values of order  $(k - 1)$  at the same place.*

Further :

V. *A continuous transition from the value of order  $k$  to that of any other, say to the value of order  $l$ , is possible at no other place than along this half-axis.*

For, when the value of order  $k$  at  $z_2$  differs infinitesimally from the value of order  $k$  at a point  $z_1$  indefinitely near, it cannot at the same time differ infinitesimally from the value of order  $l$  at  $z_1$ , which is different from it by the finite quantity  $(l - k) 2\pi$ .

(All values of the amplitude are completely undetermined at  $z = 0$  ; the point  $z = 0$  does not belong to the domain for which the amplitude function is defined.)

The conclusion from all of this is,—and it is the most important result of this investigation :

VI. *To make the amplitude a continuous function of position in the plane, we give up the notion that it is single-valued and combine its totality of values into an infinitely many-valued function.*

If two points  $z_0 z_1$  of the plane are connected by a given curve, we state the following problem :

*Some one of the values of the amplitude belonging to  $z_0$  is selected ; we wish to determine that value of the amplitude belonging to  $z_1$*

when a variable  $z$  is allowed to take on continuously all the values on the given curve and its amplitude, starting with the given initial value, changes continuously as a result of this.

The previous results give a solution of this problem, which is most simply exhibited if we assign a definite direction from  $0$  to  $-\infty$ , to the half-axis of negative real numbers, so that the upper half-plane (in which the coefficient of  $i$  is positive) lies to the right, the lower half-plane to the left, of this axis. Therefore:

VII. *Provided the assigned path does not cross the half-axis of negative real numbers, the value of the amplitude always has the same order: but whenever the curve crosses this axis once, the value of the amplitude passes to the next higher or to the next lower order according as the path crosses from right to left or from left to right.*

The special case of this theorem in which  $z_1$  coincides with  $z_0$  merits particular attention; it is stated in the following form:

VIII. *If  $z$  changes its amplitude continuously in describing a closed path, then the amplitude is finally greater by  $(p - q) 2\pi$  than before, provided the path crossed the half-axis of negative real numbers  $p$  times from right to left and  $q$  times from left to right.*

But this formulation is not yet general, inasmuch as it embodies the consideration of the half-axis of negative real numbers which in itself has nothing at all to do with the problem and which has been introduced only by our arbitrary definition of principal value. However, this limitation is removed by the following geometrical considerations. Let two non-intersecting lines  $L_1, L_2$  be drawn from zero to infinity; together they completely delimit a region which, as shown in the figure, lies to the left of  $L_1$  and to the right of  $L_2$ . Let a closed path  $\Gamma$ , definitely described, cross  $L_1$  in  $p_1$  points  $A$  from right to left, in  $q_1$  points  $B$  from left to right; and  $L_2$  in  $p_2$  points  $D$  from

right to left, and in  $q_2$  points  $C$  from left to right. At the points  $A$  and  $C$ , the curve goes into this bounded domain, at the points

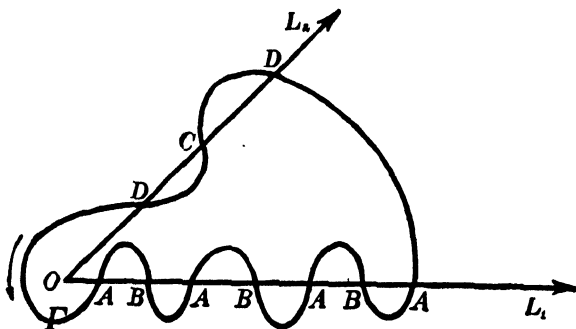

FIG. 25

$B$  and  $D$  it goes out of it. But it must go out of the domain as often as it has gone into it; hence,

$$(4) \quad \begin{cases} p_1 + q_2 = p_2 + q_1, \\ \text{or: } p_1 - q_1 = p_2 - q_2, \end{cases}$$

which leads to the theorem:

IX. *The number  $(p - q)$  appearing in Theorem VIII has the same value for all lines running from the origin to infinity.*

(The limitation made in the proof of this theorem, that  $L_1$  and  $L_2$  shall not intersect, can also be removed. For, the theorem can be proved as above for two curves  $L_1$  and  $L_2$ , which first coincide for a distance from the origin and then separate. For two such intersecting curves  $L_1$  and  $L_2$ , a third one can then be assigned which has with each of them at least one point of intersection less than  $L_1$  and  $L_2$  have with each other.)

X. *We call this number the number of circuits of the path  $\Gamma$  about the origin.*

Theorem VIII is then formulated as follows :

XI. *If  $z$  changes its amplitude continuously in describing a closed bath, then the amplitude is finally  $2\pi c$  greater than before where  $c$  is the number of circuits of the path about the origin.*

From this special case treated in the Theorems VIII–XI, it is now easy to return to the general case of Theorem VII; for, we can replace any *arbitrary* path  $z_0\alpha z_1$ , connecting a point  $z_0$  to another  $z_1$  by:

1. A *definite* path  $z_0\beta z_1$ , for example, such a one which does not cut the half-axis of negative real numbers;

2. The closed path  $z_1\beta z_0\alpha z_1$ , which is composed of this definite path (1) running in the opposite direction and the given path  $z_0\alpha z_1$ . These remarks are not limited to

the investigation of the amplitude but are true in general; they are formulated as follows :

XII. *The change in value which a many-valued function of a point undergoes while this point changes continuously in tracing an ARBITRARY PATH FROM  $Z_0$  TO  $Z_1$ , can be determined whenever the change in value of the function for a DEFINITE PATH FROM  $Z_0$  TO  $Z_1$  and for an ARBITRARY CLOSED path is known.*

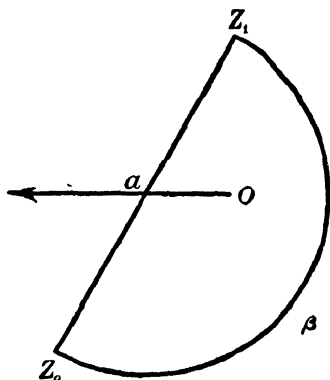

FIG. 26

### § 55. The RIEMANN'S Surface of the Amplitude

A clear geometrical representation of the relations treated in the previous paragraph is obtained by using the values of the amplitude at every point of the  $(x + iy)$ -plane as ordinates perpendicular to this plane; the end-points of these ordinates

determine a definite surface. We call the third coördinate  $\zeta$ , in a system of space coördinates of which two axes coincide with our  $x$ - and  $y$ -axes; then the coördinates of the points of this surface are expressed by two parameters as follows:

$$(1) \quad x = r \cos \phi, \quad y = r \sin \phi, \quad \zeta = \phi.$$

These are the equations of a surface well known in analytic geometry; it is called the *ordinary straight line helicoid*;\* but these equations are understood at present in a sense somewhat different from that in analytic geometry. There  $r$  and  $\phi$  are regarded as unlimited, real variables; all of the straight lines whose equations are obtained from equations (1) by giving a certain value to  $\phi$  and allowing  $r$  only to vary lie entirely on this helicoid. But in the present case  $r$  is essentially *positive*; our surface, therefore, contains only one of the two rays into which each of these straight lines is divided by their point of intersection with the  $\zeta$ -axis. However, we shall retain the name "helicoid" for the surface in the present case.

The amplitude  $\phi$  is thus a *single-valued function of position* on this surface since there is one and only one value of  $\phi$  for each point of the surface. Moreover, there is a continuous change of amplitude corresponding to a continuous progression upon the surface. To determine what final value of the amplitude is obtained at  $z_1$ , when we follow a definite curve starting from  $z_0$  with a certain initial value  $\phi_0$  and when the amplitude thus changes continuously, it is only necessary to erect a cylinder † on this curve and extend it to intersect the surface. If the curve of the  $z$ -plane does not go through the origin, and if it has no double point, then the curve of intersection of the cylinder with this surface is divided into separate branches

\* Sometimes called screw surface. — S. E. R.

† Whose element is parallel to the  $\zeta$ -axis — here a right cylinder. — S. E. R.

which have no point in common and are everywhere separated from each other by vertical distances equal to  $2\pi$ . If we then follow on the surface the branch of the curve starting from  $(x_0, y_0, \zeta_0 = \phi_0)$ , we shall never trespass on another branch of the curve if we always proceed (not by bounds but) *continuously* along the curve. We arrive finally at a definite point of the surface lying over  $z_1$ ; its ordinate represents then the desired final value of the amplitude. If the given curve of the  $z$ -plane intersects itself, then the parts of the curve made by the intersection of the cylinder with the surface intersect; moreover, the correspondence of the branches is at once evident if we notice how the separate branches of the curve starting from the point of intersection on the surface correspond to the separate branches in the plane.

This method of representation is now developed further. Complex variables were first interpreted in the plane; later, in § 13, chapter two, the sphere was used; in the same way the surface known as the helicoid may be used. For this purpose we merely attach to each point of the helicoid the same complex value which belongs to its perpendicular projection on the  $xy$ -plane; and therefore to each complex value  $z$  there belongs not one definite point of the surface as in the earlier representations, but an infinite number of points (lying in a straight line perpendicular to the  $xy$ -plane). Every function of  $x$  and  $y$ , whether it is single- or many-valued, is now considered as a function of position on the helicoid in that the values of the function belonging to a certain  $z$  are assigned to the points of the surface belonging to the same  $z$ . These results are then expressed as follows:

I. *If the amplitude of  $z$  is considered as a function of position on the helicoid, this function becomes single-valued and continuous by assigning to each point of the surface that value of the amplitude which is equal to its ordinate.*

And finally: in formula (1) the pitch of the helicoid is taken equal to  $2\pi$ . But the size of the pitch is evidently arbitrary; it can be decreased by decreasing the ordinates of all the points of the surface in the same ratio. It can finally be made indefinitely small; the entire surface is then composed of an infinite number of flat, thin sheets placed one upon the other indefinitely close and connected at the origin in the same manner as the sheets of the helicoid first considered.

II. *Such a surface, composed of a number of smooth, flat sheets connected in a definite manner, is called a plane RIEMANN'S surface.* The one considered here has an infinite number of sheets extended over the whole  $z$ -plane. Its sheets are all connected with each other at the point  $z=0$ ; this point  $z=0$  is therefore for this surface a *branch-point\** of infinitely high order. Over every other point of the  $z$ -plane (even over the points of the half-axis of negative real numbers) the sheets remain separate and are arranged simply one upon another.

The same surface is also obtained in another way as follows: we cut the  $z$ -plane along the half-axis of negative real numbers from  $0$  to  $-\infty$ . Let us consider an infinite number of such  $z$ -planes cut in this way, and let us number them by an index  $k$  which takes all integral values from  $-\infty$  to  $+\infty$ . Let us now arrange them one upon another, so that the  $(k+1)$ th sheet is the next above the  $k$ th. Finally let us connect the right bank of the cut in the  $k$ th sheet with the left bank of the cut in the  $(k+1)$ th sheet.

III. *Upon this surface, constructed in either manner, the values of the amplitude are thus arranged as a single-valued and*

\* That is, if a point  $z$  makes a complete circuit of a point  $P$  in the  $z$ -plane and returns to its original position, and in so doing the value of  $w$  (the function) is always changed, then the point  $P$  is called a *branch-point*. As an illustration of how the function-values pass into one another on describing closed paths around a branch-point, cf. Exs. 1, 3, 5, end of § 59. — S. E. R.

*continuous function of position*; and this is the final result of the discussion.

We shall frequently have occasion in what follows to use such "*RIEMANN'S surfaces*" to represent graphically the relation between the different values of a many-valued function. In this connection it seems most practical to think of the surface as extended over the sphere and not over the plane; such a representation is obtained by projecting the plane, that is, the surface spread out upon it, stereographically (§ 13) upon the sphere. This is of no particular use in the case just considered; however, in this transformation from the plane to the sphere we observe that the half-axis of negative real numbers corresponds to a half-meridian which connects the points  $O$  and  $O'$ . We notice too that the sheets are connected at the latter point just as at the former, with this difference however, that if we regard the sheets about  $O$  as "wound right-handed,"\* then those about  $O'$  are "wound left-handed." For, a line upon the sphere which encircles the point  $z=0$  in the positive sense, that is, so that this point always lies to the left in passing along the curve, has at the same time the point at infinity to the right and encircles it therefore in the negative sense.

A further explanation is necessary in order to avoid misunderstandings that might otherwise arise. In the above paragraphs we have frequently spoken of "sheets" of the surface; this was due chiefly to the way in which the surface was constructed from planes cut along the half-axis of negative real numbers; and therefore upon the arbitrary, fixed definition of the principal value of the amplitude. The joining of the sheets at the cut is not visible on the completed surface; but such connection and the resulting individual sheets become evident by supposing an arbitrary, vertical cut through all the sheets

\* As is customary in technics but different in botany.

running from 0 to  $\infty$ . We notice too that two points which are vertical to the same point in the plane and which lie in different sheets for *one* such cut lie in different sheets for *any* such cut. But, given two points of the surface which are situated above different points of the plane, we can then choose the position of the cut so that these points lie in the same sheet or in different sheets of the surface. *Hence the expression "two points of the same sheet" always has a definite meaning only with regard to a definite cut previously chosen (cf. end § 59).*

### § 56. The Logarithm

The value of the integral

$$(1) \quad \int_1^z \frac{d\xi}{\xi},$$

according to VI, § 35, is a regular function of its upper limit inside of every simply connected domain which contains within it the point  $z = 1$  but neither the origin nor the point at infinity, — provided that the path of integration also lies entirely in the domain. (The origin and the point at infinity must here be excluded, since the function to be integrated has a pole in the first case, and while the function remains regular in the second case it is not zero of order higher than the first; cf. IV, § 45.)

If  $z$  is real and positive, and if the axis of positive real numbers is chosen as the path of integration, then the value of integral (1) is, as is well known, equal to the natural logarithm of  $z$ . We retain here this name and the corresponding symbol for the function for the case where  $z$  is a complex number; we define accordingly:

I. *The natural logarithm of a complex number  $z$ ,  $\log z$ , is any one of the values which integral (1) takes on when the path of integration is arbitrary.*

The determination of the values of the logarithm of a complex number is made to depend upon functions of real variables known in elementary analysis, by representing the complex numbers in terms of their absolute values and amplitudes as in § 4. For this purpose we put

$$(2) \quad z = r(\cos \phi + i \sin \phi)$$

$$(3) \quad \zeta = \rho(\cos \psi + i \sin \psi).$$

To discuss the simplest case let us take as the required path of integration a piece of the axis of real numbers from 1 to  $|z|$  and an arc of a circle whose center is at the origin and which connects the points  $|z|$  and  $z$  (Fig.

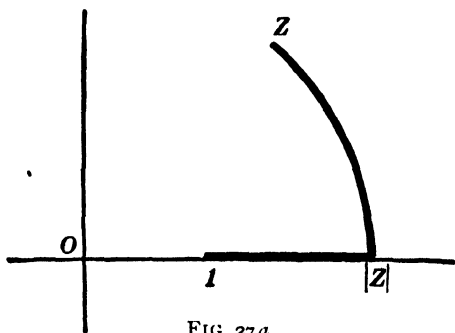

FIG. 27a

27). Along the first part of this path  $\psi = 0$ ,  $\zeta = \rho$ ,  $d\zeta = d\rho$  and  $\rho$  takes on all the values from 1 to  $|z|$ . For this part of the path the following integral,

$$(4) \quad \int_1^{|z|} \frac{d\rho}{\rho} = \text{Log } |z| *$$

taken along the real path between the real limits is, therefore, a special case of the integral (1); and  $\text{Log } |z|$  is here understood to be

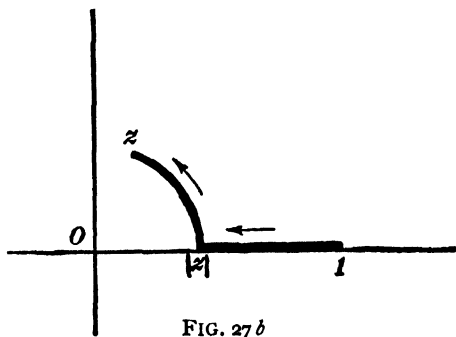

FIG. 27b

\* The capital here indicates, as in Ex. 3 at the end of § 56, a definite "branch" of the logarithm called the principal value of the logarithm (cf. IV). In what follows it will be so written. — S. E. R.

the real natural logarithm of the real positive number  $|z|$ , defined in elementary mathematics. If  $\rho$  is constant and  $\rho = |z|$  along the second part of the path of integration, then,

$$(5) \quad d\xi = |z| (-\sin \psi + i \cos \psi) d\psi = i\xi d\psi,$$

and  $\psi$  takes on all the real values from 0 to  $\phi$ . For the second part of the path we therefore have a special case of the integral (1) equal to  $i$  times the integral

$$(6) \quad \int_0^\phi d\psi = \phi$$

taken along the real path. This integral defines  $\phi$ ; for  $\phi$  we therefore take that value of the amplitude of  $z$  which, according to § 54, is obtained when  $z$ , starting from  $|z|$ , traces the prescribed arc of a circle, and when the amplitude thus starting from 0 changes continuously. Every value of the amplitude can therefore be obtained by allowing the prescribed arc of a circle to include more than a whole circumference.

The result thus found for this special kind of path of integration is true generally. For, every arbitrary preassigned path from  $\mathfrak{r}$  to  $z$  may be deformed, without passing through the origin or through infinity, to a path of the kind just considered. It therefore follows, according to V, § 35, that the values thus found represent the totality of the values of  $\log z$  determined by definition (1). The results of the investigation are expressed completely as follows :

II. *The totality of values of the logarithm of the complex number  $z = r \cdot e^{i\phi}$  is given by the formula*

$$(7) \quad \log z = \text{Log } r + i\phi$$

*in which  $\text{Log } r$  is the real logarithm of the absolute value of  $z$ , and  $\phi$  is an arbitrary value of its amplitude.*

III. *The logarithm of a complex variable, as it is defined by (1), is thus an infinitely many-valued function, the totality of whose values is obtained from any one of them by the addition of arbitrary integral multiples of  $2\pi i$ .*

IV. *By using the principal value of the amplitude a definite "branch" of this infinitely many-valued function is obtained; it is called the principal value of the logarithm.\**

A real positive number is a particular case of a complex variable. As such it therefore has infinitely many logarithms in the sense defined here; of these the principal value is identical with the real logarithm defined in an elementary way, the others have imaginary parts which are even multiples of  $\pi i$ . The imaginary parts of logarithms of negative real numbers are odd multiples of  $\pi i$ .

V. *As the basis for representing the logarithm as a single-valued function of position we use, therefore, the RIEMANN'S surface studied in the previous paragraph.*

It is essential that we study now the most important properties of the logarithmic function as defined. The first of these properties is that each of its branches is regular, according to VI, § 35, in every domain which lies entirely in the finite part of the plane, which is simply connected, and which does not contain the origin within it; it can then be developed in a TAYLOR'S series in the neighborhood of every point excepting only  $0$  and  $\infty$ . The coefficients of this development are determined from the defining equation (1) by successive differentiation; it thus follows that

$$(8) \quad \frac{d^n \log z}{dz^n} = (-1)^{n-1} \frac{(n-1)!}{z^n}$$

\* Thus, that value of  $\log [z = r(\cos \phi + i \sin \phi)]$  for which  $-\pi < \phi \leq \pi$  is written  $\text{Log } z = \text{Log}(r = |z|) + i \text{Am } z$ . — S. E. R.

just as when  $z$  is real. We observe in particular:

VI. *The development of the principal value in powers of  $(z - 1)$  is*

$$(9) \quad \text{Log } z = (z - 1) - \frac{(z - 1)^2}{2} + \frac{(z - 1)^3}{3} - \frac{(z - 1)^4}{4} + \dots$$

The elementary logarithm of a positive real number has also the fundamental property that

$$(10) \quad \log(z_1 z_2) = \log z_1 + \log z_2.$$

In order to investigate whether and in what sense this property also holds for the infinitely many-valued function of complex argument designated here by the name logarithm, we start from the fact that each preassigned path from 1 to  $z_1 z_2$  can be so deformed as to make it pass through the point  $z_1$  without in this way changing the value of the integral:

$$(11) \quad \int_1^{z_1 z_2} \frac{d\zeta}{\zeta} = \log z_1 z_2.$$

This integral, for all of its values, can now be written in the form of the sum:

$$(12) \quad \int_1^{z_1} \frac{d\zeta}{\zeta} + \int_{z_1}^{z_1 z_2} \frac{d\zeta}{\zeta}$$

by suitably choosing the two paths of integration. The first one of these integrals is a value of  $\log z_1$ ; let us introduce a new variable of integration  $\eta$  in the second by the substitution:

$$(13) \quad \zeta = z_1 \eta.$$

We have investigated this substitution in § 9; it is reversibly unique over the whole plane. To the path from  $z_1$  to  $z_1 z_2$  previously determined in the  $\zeta$ -plane, there corresponds then point for point in the  $\eta$ -plane a definite path from  $\eta = 1$  to  $\eta = z_2$ ;

and therefore the second integral of (12) may be replaced by

$$\int_1^{z_2} \frac{d\eta}{\eta} = \text{a value of } \log z_2.$$

Thus the validity of (10) for complex arguments is proven in the sense that if any value is assigned to the left-hand side we can always so choose the values of the logarithms on the right-hand side that the equation is satisfied. We can even choose arbitrarily the value of one of the two logarithms on the right-hand side and then determine the other so that the equation remains true. For, when a path from 1 to  $z_1 z_2$  and one from 1 to  $z_1$  are agreed upon, another path from  $z_1$  to  $z_1 z_2$  can always be so determined that all three paths together form a closed curve which encircles the origin zero times (X, § 54).

Conversely each value of the right-hand side of (10) is equal to a value of the left-hand side. For, suppose arbitrary paths from 1 to  $z_1$  and from 1 to  $z_2$  are given; by means of the substitution (13) a definite path from  $z_1$  to  $z_1 z_2$  corresponds to the path from 1 to  $z_2$ , and this then combined with the path from 1 to  $z_1$  gives a definite path from 1 to  $z_1 z_2$ . On this account therefore,

VII. *Equation (10) is true for complex arguments  $z$  in the sense that every value of the right-hand side is equal to a value of the left-hand side and conversely, and that then the totality of values of the two sides coincide.\**

Having once determined the equality of any values whatever of the two sides, we might have derived therefrom that both sides of the equation have the same degree of many-valuedness, since for both sides the transition from one value to any other takes place by the addition of arbitrary integral multiples of

\* That is, it is a *complete* equation, or one which is *completely true*. — S. E. R.

$2\pi i$ . The method pursued shows further *how* the third path is to be chosen, when two paths of integration are given, in order to satisfy the equation.

In other equations between many-valued functions the conditions may be entirely different. If, for example, we put  $z_1 = z_2 = z$  in equation (10), we conclude that the two paths on the right-hand side should coincide (or at least encircle the origin equally often), and it then follows from the first proof of Theorem VII that in the resulting equation

$$(14) \quad \log(z^2) = 2 \log z$$

every value of the right-hand side is equal to a value of the left-hand side. But if we prescribe the path from 1 to  $z^2$  and one of the paths from 1 to  $z$  we can *not* conclude that the path from  $z$  to  $z^2$ , compounded from the return path from  $z$  to 1 and the path from 1 to  $z^2$ , is transformed by the inverse of substitution (13) into a second path from 1 to  $z$  which coincides with the prescribed one from 1 to  $z$  or which may be reduced to it without going through the origin. From the second method we see that the left-hand side of (14) is determined only for integral multiples of  $2\pi i$ , the right-hand side only for such multiples of  $4\pi i$ . We find accordingly that:

VIII. *In equation (14) every value of the right-hand side is equal to a value of the left-hand side, but the left-hand side may have the values of  $2 \log z + 2\pi i$  in addition to this.*

It is important to notice also that equations (10) and (14) are not always true if we use only the principal values of all the logarithms in them, as simple values show (put, for example,  $z = e^{\frac{3\pi i}{4}}$  in (14)).

## EXAMPLES

1. Any value of  $\log z$  is a continuous function of both  $x$  and  $y$ , except when  $x = 0$ ,  $y = 0$ . Prove.

2. Show that in the equation

$$\log(z_1 z_2) = \log z_1 + \log z_2$$

every value of either side is *one* of the values of the other side.

HINT. — Put  $z_1 = r_1(\cos \theta_1 + i \sin \theta_1)$  and  $z_2 = r_2(\cos \theta_2 + i \sin \theta_2)$ , and apply the formula.

3. Show that  $\text{Log}(z_1 z_2) = \text{Log } z_1 + \text{Log } z_2$ , is not true in all cases.

For example if  $z_1 = z_2 = 1/2(-1 + i\sqrt{3}) = \cos \frac{2\pi}{3} + i \sin \frac{2\pi}{3}$ , then  $\text{Log } z_1 = \text{Log } z_2 = \frac{2}{3}\pi i$  and  $\text{Log } z_1 + \text{Log } z_2 = \frac{4}{3}\pi i$ , which is one of the values of  $\log(z_1 z_2)$ , but not the principal value.

What is the value of  $\text{Log}(z_1 z_2)$  for the special value of  $z_1$  and  $z_2$ ?

*Ans.*  $(-2/3)(\pi i)$ .

4. Show that in the equation

$$\log z^m = m \log z, \quad m \text{ being an integer,}$$

every value of the right-hand side is a value of the left-hand side, but that the converse is not true. What values belong to the left-hand side of this equation that are *not* values of the right-hand side?

5. Is the equation of Ex. 3 above true if the line from  $z_1$  to  $z_2$  cuts the negative half of the real axis?

6. Show that the equation

$$\text{Log}\left(\frac{z-a}{z-b}\right) = \text{Log}(z-a) - \text{Log}(z-b)$$

is true if  $z$  lies outside of the domain bounded by the line joining the points  $z = a$  and  $z = b$  and lines through these points

parallel to the  $x$ -axis and extending to infinity in the negative direction.

7. The equation

$$\operatorname{Log} \left( \frac{a-z}{b-z} \right) = \operatorname{Log} (1 - a/z) - \operatorname{Log} (1 - b/z)$$

is true if  $z$  lies outside the triangle formed by the three points  $o$ ,  $a$ ,  $b$ . Prove.

8. If  $z = x + iy$ , then  $\log \log z = \operatorname{Log} R + (\theta + 2k'\pi)i$  where

$$R^2 = (\operatorname{Log} r)^2 + (\theta + 2k\pi)^2$$

and  $\theta$  is the least positive angle determined by the equations,

$$\cos \theta : \sin \theta : 1 :: \operatorname{Log} r : \theta + 2k\pi : \sqrt{(\operatorname{Log} r)^2 + (\theta + 2k\pi)^2}.$$

Plot roughly the doubly infinite set of values of  $\log \log (1 + i\sqrt{3})$ , indicating which of them are values of  $\operatorname{Log} \log (1 + i\sqrt{3})$  and which of  $\log \operatorname{Log} (1 + i\sqrt{3})$ .

9. Is the equation  $a^b = (a^2)^3$  a complete equation? Show by use of logarithms.

10. Are the equations

$$\operatorname{am} \left( \frac{z_1}{z_2} \right) = \operatorname{am} z_1 - \operatorname{am} z_2 \text{ and } \operatorname{Am} \left( \frac{z_1}{z_2} \right) = \operatorname{Am} z_1 - \operatorname{Am} z_2$$

complete equations?

11. Show that the exponential function  $\exp z$  or  $e^z$  is a single-valued function of  $z$ .

12. When  $x$  is negative, how does  $\log x$  differ from  $\log |x|$  or from  $(1/2) \log x^2$ ?

13. We know that  $\lim_{w \neq 0} \left\{ \frac{\log (1+w)}{w} \right\} = 1$  when  $w$  is real.

This result may be extended to complex values of  $w$ . For,

$$\log (1+w) = \int_1^{1+w} dz/z,$$

§ 56. THE LOGARITHM

the path of integration being the straight line from 1 to  $1 + w$ . This line is represented by the equations

$$x = 1 + t\rho \cos \phi, \quad y = t\rho \sin \phi, \quad 0 \leq t \leq 1,$$

$\rho$  being the modulus and  $\phi$  the amplitude of  $w$ . Thus

$$\log(1 + w) = \int_0^1 \frac{\rho(\cos \phi + i \sin \phi) dt}{1 + t\rho(\cos \phi + i \sin \phi)},$$

and

$$\begin{aligned} (1/w) \log(1 + w) &= \int_0^1 \frac{dt}{1 + t\rho(\cos \phi + i \sin \phi)} \\ &= 1 - \rho \int_0^1 \frac{t(\cos \phi + i \sin \phi) dt}{1 + t\rho(\cos \phi + i \sin \phi)}. \end{aligned}$$

The modulus of the last term is less than

$$\rho \int_0^1 \frac{t dt}{\sqrt{1 + 2t\rho \cos \phi + t^2\rho^2}} < \rho \int_0^1 \frac{t dt}{1 - t\rho} < \frac{\rho}{1 - \rho} \int_0^1 t dt = \frac{\rho}{2(1 - \rho)}$$

which approaches zero with  $\rho$ , and hence  $\lim_{w \neq 0} \left\{ \frac{\log(1 + w)}{w} \right\} = 1$ .

If  $w = u + iv$ , and  $u$  and  $v$  each approach zero, then  $w$  approaches the origin along a path the nature of which depends upon the way in which  $u$  and  $v$  approach zero, or on the relations which hold between them in the process. Thus if  $u$  were always equal to  $v$ , the path would be a straight line bisecting the angle between the axes. Thus  $\frac{\log(1 + w)}{w}$  approaches 1 as  $w$  approaches zero.

**14.** Show that the formula  $\frac{d}{dt} \log \phi(t) = \phi'(t)/\phi(t)$  holds generally when  $\phi$  is a complex function of the real variable  $t$ . Put  $\phi = u + iv$  and  $\log \phi = (1/2) \log(u^2 + v^2) + i \tan^{-1}(v/u)$  and differentiate according to the usual formulas.

### § 57. Conformal Representation Determined by the Logarithm

We investigate now the conformal mapping of the  $z$ -plane upon the  $w$ -plane determined by the function :

$$(1) \quad w = \log z;$$

in this connection we keep in mind the principal value of the logarithm. In the theory of the real logarithm of a real positive number  $|z|$  it is known that such a logarithm takes on real values continually increasing from  $-\infty$  to  $+\infty$  as  $|z|$  increases from 0 to  $\infty$ . Further,  $\phi$  continually increasing passes from  $-\pi$  to  $+\pi$  as  $z$  describes a circle about the origin in the positive sense, starting at its intersection with the negative  $x$ -axis and returning to that place. Since a circle about the origin and a radius vector starting at the origin can intersect in only one point, it follows that :

#### I. The principal value

$$(2) \quad w = u + iv$$

of the logarithm takes on each finite complex value at one and only one point of the plane providing the imaginary part  $v$  satisfies the inequality :

$$(3) \quad -\pi < v \leq +\pi.$$

But, expressed geometrically, this means that :

II. The  $z$ -plane cut along the half-axis of negative real numbers is mapped conformally by the principal value of the logarithm upon the parallel strip of the  $w$ -plane bounded by the lines  $v = -\pi$  and  $v = +\pi$ .

Thus the parallels to the  $u$ -axis correspond to the rays of the  $z$ -plane starting at the origin, the parallels to the  $v$ -axis correspond to the concentric circles about the origin in the  $z$ -plane.

Going now from the principal value to the other values of the logarithm, we find that :

III. *The  $z$ -plane cut along the half-axis of negative real numbers is mapped by the  $k$ th value of the logarithm upon that strip of the  $w$ -plane bounded by the parallels :*

$$v = (2k - 1)\pi, \quad v = (2k + 1)\pi.$$

The maps of the  $z$ -plane upon the  $w$ -plane determined by the different branches of the logarithmic function are therefore contiguous throughout the  $w$ -plane and finally cover the whole of it once without gaps. From this it follows that :

IV. *There is always one, and only one, value of  $z$  (finite and different from zero), for which one of the values of  $\log z$  is equal to an arbitrary, preassigned finite complex number  $w$ .*

Let us, therefore, consider  $z$  as a function of  $w$ , that is, the problem “to revert the logarithm.” We find that this function is single-valued over the whole plane. It is further *continuous* over the whole plane, as is seen from the definition of the logarithm by means of the definite integral ; moreover, the continuity is not broken at the boundaries of the parallel strips, as we see from the results of §§ 54, 55 relative to the continuous connection between the different branches of the logarithm (or amplitude). Finally, this function has a definite first derivative over the whole plane :

$$(4) \quad \frac{dz}{dw} = 1 / \frac{dw}{dz} = z ;$$

and thus  $z$  is finite and different from zero for all finite values of  $w$ . In consequence of Theorem IX, § 38, and the definition of a regular function, we therefore have :

V. *The inverse of the logarithm is a function regular over the whole plane and is therefore a transcendental integral function.*

Having obtained this result we may now use the method of undetermined coefficients to determine the coefficients of the corresponding series by substituting

$$z = \sum_{n=0}^{\infty} A_n w^n$$

in the differential equation (4). The following recursion formula for  $A_n$  is thus obtained:

$$nA_n = A_{n-1};$$

and as  $A_0$  must be equal to 1 (since  $z = 1, w = 0$  is a pair of corresponding values), we use this formula to determine the coefficients  $A_n$  successively. We thus obtain:

$$(5) \quad z = 1 + \sum_{n=1}^{\infty} \frac{w^n}{n!}, \text{ that is:}$$

VI. *The inverse of the logarithm is the exponential function of complex argument discussed in § 40.*

We might also have obtained this result in many other ways, for example, by reverting the series (9), § 56, in the sense of  $X$ , § 46, or by showing that the conformal mapping determined by the logarithm is exactly the inverse of the conformal mapping determined by the exponential function. The method used here is important, since it can be used in complicated cases to determine whether a proposed problem of inversion can be solved in terms of a single-valued function. To avoid misunderstandings, we state further that it is not sufficient in the proof of Theorem V to show that the inverse function is regular in the neighborhood of every point of the domain for which it is defined; it is much more essential that we obtain a clear conception of the form of this defining domain; this is most easily done by investigating the conformal mapping.

EXAMPLES

1. For the transformation  $w = \log z$  find the curves in the  $z$ -plane which correspond respectively to the lines  $u = \text{const.}$  and  $v = \text{const.}$

$$\begin{aligned} \text{If} \quad & z = x + iy = r(\cos \theta + i \sin \theta) \\ \text{and} \quad & w = u + iv = \rho(\cos \phi + i \sin \phi), \\ \text{then} \quad & x = e^u \cos v, \quad u = \log r, \\ & y = e^u \sin v, \quad v = \theta + 2k, \end{aligned}$$

where  $k$  is any integer. Describe the motion of  $z$  while  $w$  describes the whole of a line parallel to the  $v$ -axis.

2. Show that to a straight line in the  $w$ -plane corresponds, by the transformation  $w = \log z$ , an equiangular spiral in the  $z$ -plane.

2 *a.* If, in the stereographic projection defined in Ex. 1, at the end of § 13, we introduce a new complex variable

$$w = u + iv = -i \cdot \log(z/2) = -i \cdot \log [(1/2)(x + iy)]$$

so that  $u = \phi$ ,  $v = \log \cot \frac{\theta}{2}$ , we obtain another map of the surface of the sphere usually called *MERCATOR'S Projection*. On this map parallels of latitude and longitude are represented by straight lines parallel to the axes of  $u$  and  $v$  respectively.

NOTE.—The problem of making maps of the earth's surface by applying the principles of stereographic projection and conformal representation is of great interest. The discovery of the compass brought with it the idea of steering a course making with all meridians a constant angle. This course was a spiral and was called a rhumb line or loxodrome. If the earth's surface (regarded as a sphere) be inverted from any point of the surface, say the north pole, into a plane, for example into the plane tangent at the south pole, the meridians become a pencil of rays through the origin in the plane and the loxodromes are then, by isogonality, curves cutting this pencil at a constant angle, that is, equiangular spirals. But the map so formed by stereo-

graphic projection was not sufficiently simple since the loxodromes were the important lines. A map was wanted on which the loxodromes would appear as straight lines. This was accomplished by mapping the inverse of the sphere by means of  $w = \log z$ . And this, then, is the principle of MERCATOR'S *Projection*.

Of the memoirs which treat of the construction of maps of surfaces as a special question, the most important are those of LAGRANGE, *Collected Works*, Vol. IV, pp. 635-692, and GAUSS, *Ges. Werke*, Vol. IV, pp. 189-216. Also a treatise by HERZ, *Lehrbuch der Landkartenprojectionen*, Teubner, 1885.

2 *b*. Discuss the map determined by the equation

$$z = \log \{(w - a)/(w - b)\},$$

showing that the straight lines for which  $x$  and  $y$  are constant correspond to two orthogonal systems of coaxial circles in the  $w$ -plane.

3. Find all the values of  $i^i$ .

By definition  $i^i = \exp(i \log i)$ .

But  $i = \cos \frac{\pi}{2} + i \sin \frac{\pi}{2}$ ,  $\log i = \left(2k\pi + \frac{\pi}{2}\right)i$ ,

where  $k$  is any integer. Thus,

$$i^i = \exp \{ -(2k + 1/2)\pi \} = e^{-(2k+1/2)\pi}.$$

The values of  $i^i$  are, therefore, all real and positive.

4. Find all the values of  $(1 + i)^i$ ,  $i^{(1+i)}$ ,  $(1 + i)^{(1+i)}$ .

5. Find the general value of  $a^z$ . Let

$$z = x + iy, \quad a = \rho(\cos \theta + i \sin \theta)$$

where  $-\pi < \theta \leq \pi$ .

By definition  $a^z = \exp(z \log a)$ .

But  $z \log a = (x + iy)\{\text{Log } \rho + (\theta + 2m\pi)i\} = L + iM$ ,

where  $L = x \log \rho - y(\theta + 2m\pi)$ ,  $M = y \log \rho + x(\theta + 2m\pi)$

and  $a^z = \exp(z \log a) = e^L(\cos M + i \sin M)$ .

Therefore the general value of  $a^z$  is

$$e^{z \log \rho - y(\theta + 2m\pi)} [\cos \{y \log \rho + x(\theta + 2m\pi)\} + i \sin \{y \log \rho + x(\theta + 2m\pi)\}].$$

This is in general an infinitely many-valued function corresponding to the different values of  $m$  unless  $y = 0$ . But even if  $y = 0$  and  $z$  irrational, there are an infinite number of values each of which have the same modulus.

6. Find the *principal value* of  $a^z$ . (Put  $m = 0$  in the general formula.)

7. There are two particular cases in Ex. 5 that are of interest: (I) if  $a$  is real and positive and  $z$  real, then  $\rho = a$ ,  $\theta = 0$ ,  $x = z$ ,  $y = 0$ , and the principal value of  $a^z$  is  $e^{z \log a}$ ; but (II) if  $|a| = 1$  and  $z$  is real, then  $\rho = 1$ ,  $x = z$ ,  $y = 0$  and the principal value of  $(\cos \theta + i \sin \theta)^z$  is  $(\cos z\theta + i \sin z\theta)$ , — a generalization of DE MOIVRE'S theorem.

8. Find the general value and also the principal value of  $e^z$ . (For the general value put  $e$  for  $a$  in the general formula so that  $\log \rho = 1$ ,  $\theta = 0$ . The principal value of  $e^z$  is  $e^z (\cos y + i \sin y)$ .)

9. Show that  $\log(e^z) = (1 + 2m\pi i)z + 2n\pi i$ ,  $m$  and  $n$  being any integers, and that in general  $\log(a^z)$  has a double infinity of values.

10. In what cases are any of the values of  $x^z$ , where  $x$  is real, themselves real?

If  $x > 0$ , then

$x^z = \exp(x \log x) = \{\exp(x \operatorname{Log} x)\} (\cos 2m\pi x + i \sin 2m\pi x)$  the first factor of which is real. The principal value, for which  $m = 0$ , is always real.

If, however,  $x$  is a rational fraction of the form  $\frac{p}{2q+1}$ , or is irrational, there is no other real value. But if  $x$  is of the form

$p/2 q$  there is one other value, viz.:  $\exp(x \operatorname{Log} x)$  given by  $m = q$ .

If  $x = -h (< 0)$ , then

$$x^x = \exp \{ -h \log(-h) \} = [\exp(-h \operatorname{Log} h)](\cos \theta + i \sin \theta)$$

where  $\theta = -(2m + 1)\pi h$ . The only case in which any value is real is that for which  $h = \frac{p}{2q + 1}$ , whence  $m = q$  gives the real value,

$$\exp(-h \operatorname{Log} h) \{ \cos(-p\pi) + i \sin(-p\pi) \} = (-1)^p h^{-h}.$$

The cases of reality are illustrated by the following examples:

$$(1/3)^{\frac{1}{3}} = 1/\sqrt[3]{3}, \quad (1/2)^{\frac{1}{2}} = \pm 1/\sqrt{2}, \quad (-2/3)^{-\frac{2}{3}} = \sqrt[3]{(3/2)^2}, \\ (-1/3)^{-\frac{1}{3}} = -\sqrt[3]{3}.$$

11. Show that the real part of  $i^{1 \cdot \log(1+i)}$  is

$$e^{-\frac{1}{8}(4k+1)\pi^2} \cdot \cos \left\{ \frac{1}{4}(4k+1)\pi \log 2 \right\},$$

where  $k$  is any integer. How does this differ from the real part of  $i^{\log(1+i)}$ ?

12. The values  $a^z$  when plotted on the ARGAND diagram are the vertices of an equiangular polygon inscribed in an equiangular spiral whose angle is independent of  $a$ . (*Math. Trip.*, 1899.)

If  $a^z = r(\cos \theta + i \sin \theta)$ ,

then  $r = e^{x \log \rho - y(A + 2m\pi)}$ ,  $\theta = y \log \rho + x(A + 2m\pi)$ ,  $-\pi < A \leq \pi$ ,

and all the points lie on the spiral  $r = \rho^{\frac{(x^2+y^2)}{x}} \cdot e^{-y\theta/x}$ .

13. Explain the fallacy in the following argument: since  $e^{2m\pi i} = e^{2n\pi i} = 1$ , where  $m$  and  $n$  are any integers, therefore raising each side to the power  $i$  we obtain  $e^{-2m\pi} = e^{-2n\pi}$ .

14. How is the theory of logarithms, as laid down here, harmonized with the elementary notion of a logarithm such as  $\log_{10} 100 = 2$ , and such as  $\int_1^x dt/t = \log x$ ?

We may define  $w = \log_a z$  in two different ways: (I) we may put  $w = \log_a z$  if the *principal* value of  $a^w$  is equal to  $z$ ; (II) we may say that  $w = \log_a z$  if *any* value of  $a^w$  is equal to  $z$ .

Hence if  $a = e$ , then  $w = \log_e z$  according to the first definition if the principal value of  $e^w$  is equal to  $z$ , or if  $\exp w = z$ ; and thus  $\log_e z$  is identical with  $\log z$ . But, by the second definition,  $w = \log_e z$  if

$$e^w = \exp(w \log e) = z, \quad w \log e = \log z,$$

or  $w = \frac{\log z}{\log e}$ , any values of the logarithms being taken. Thus

$$w = \log_e z = \frac{\text{Log}|z| + (\text{Am } z + 2 m\pi)i}{1 + 2 n\pi i},$$

so that  $w$  is a doubly infinitely many-valued function of  $z$ . And generally, according to this definition,  $\log_a z = \frac{\log z}{\log a}$ .

15. Show that  $\log_e (1) = 2 m\pi i / (1 + 2 n\pi i)$ ,  $\log_e (-1) = (2 m + 1)\pi i / (1 + 2 n\pi i)$ ,  $m$  and  $n$  being any integers.

### § 57 a. The Function $\tan^{-1}z$

In § 56 we defined the logarithmic function for a complex argument by the integral

$$(1) \quad \log z = \int_1^z \frac{d\zeta}{\zeta}.$$

We now introduce a new variable of integration  $\mathbf{Z}$  in this integral by the following substitution already investigated in § 15;

$$(2) \quad \zeta = \frac{1 + i\mathbf{Z}}{1 - i\mathbf{Z}}, \quad \mathbf{Z} = i \frac{1 - \zeta}{1 + \zeta}, \quad d\zeta = \frac{2 i d\mathbf{Z}}{(1 - i\mathbf{Z})^2}.$$

The integral is thus transformed into

$$(3) \quad 2i \int_0^z \frac{dZ}{1+Z^2};$$

the new upper limit is connected with the old one by the same equation as the new variable of integration is with the old variable; that is,

$$(4) \quad z = \frac{1+iZ}{1-iZ}, \quad Z = i \frac{1-z}{1+z}.$$

But when an integral between complex limits is to be transformed by the introduction of a new variable of integration we must be careful, in general and hence here, that the limits of the two integrals correspond to each other and also that the paths of integration correspond—at least whenever we are dealing with an integral which is not completely independent of the path. The logarithm has infinitely many values according to the choice of the path of integration; we have arbitrarily chosen one of these values as principal value. We shall obtain the best notions concerning the new integral by using the principal value. In defining the principal value of the amplitude and subsequently the principal value of the logarithm, we drew a cut in § 54 along the half-axis of negative reals and prohibited the path of integration from crossing this cut. It is essential, therefore, to determine first what lines of the  $Z$ -plane correspond to this cut in the  $z$ -plane. From the results of §§ 14 and 15 we know already that a straight line of the  $z$ -plane corresponds to a circle or again to a straight line of the  $Z$ -plane; since a circle is completely determined by three of its points, it will only be necessary to find the points of the  $Z$ -plane corresponding to three points of this cut. As in § 15, following (3), we have the following pairs of corresponding values :

$$\begin{array}{ccc} z = 0 & -1 & \infty \\ Z = i & \infty & -i. \end{array}$$

The cut in the  $z$ -plane thus corresponds in the  $Z$ -plane to that part of the axis of pure imaginaries which runs from  $Z = i$  through infinity to  $Z = -i$ . We obtain accordingly the principal value of the logarithm when we so choose the path of integration for the integral (3) that it does not cross this part of the  $Z$ -axis. The remaining values then follow from this principal value by the addition of arbitrary integral multiples of  $2\pi i$ .

Integral (3) without the factor  $2i$  receives a specific name based upon the usual terminology in the theory of functions of a real variable; we define:

I. The symbol  $\tan^{-1}Z$

also denotes for complex values of  $Z$  any one of the values of the integral

$$(5) \quad \int_0^Z \frac{dZ}{1+Z^2}$$

which is obtained when the path of integration is chosen arbitrarily (excepting of course that this path cannot be taken through one of the points  $+i$  or  $-i$ , since this symbol of integration would then have no meaning).

II. From this totality of values we then select as the principal value that one which is obtained when the path of integration is not allowed to cross the cut described above.

We have then the theorems:

III. All the remaining values of the function  $\tan^{-1}Z$  are obtained from the principal value of this function by the addition of arbitrary integral multiples of  $\pi$ .

Also (on account of Theorem I, § 57):

IV. The principal value of the inverse tangent takes on each complex value  $w$ , whose real part  $u$  satisfies the inequality

$$(6) \quad -\frac{\pi}{2} < u \leq \frac{\pi}{2}$$

at one and only one point of the plane;

or geometrically :

V. *The  $Z$ -plane cut in the manner specified above is mapped conformally by the principal value of the function  $\tan^{-1}Z$  upon the parallel strip of the  $w$ -plane bounded by the straight lines*

$$(7) \quad u = -\pi/2, \quad u = +\pi/2.$$

In this transformation the parallels to the  $v$ -axis correspond to the circles through the two points  $Z = +i$  and  $Z = -i$ , the parallels to the  $u$ -axis to the circles which cut those through  $i$  and  $-i$  at right angles ; in particular the  $u$ -axis corresponds to the  $X$ -axis, the  $v$ -axis to that part of the  $Y$ -axis from  $Z = -i$  to  $Z = +i$ .

We get likewise from the corresponding theorem on the logarithm :

VI. *There is always one and only one value of  $Z$  for which one of the values of  $\tan^{-1}Z$  is equal to an arbitrary preassigned complex number  $w$ .*

It thus follows, as in § 57, that the inverse of the function  $w = \tan^{-1}Z$  is a function of  $w$  which is single-valued in the whole plane. But it is not regular in the whole plane. For, by means of the principal value of the function  $\tan^{-1}Z$  a point of the  $Z$ -plane at infinity corresponds to a point of the  $w$ -plane at a finite distance from the origin, viz. to the point  $w = \pi/2$ . Conversely, for the inverse function not a finite but an infinitely great value corresponds to the point  $w = \pi/2$ ; and the same is then true for all those values which are obtained from  $w = \pi/2$  by the addition of integral multiples of  $\pi$ .

To investigate the behavior of the inverse function in the neighborhood of such a point, we use the process of inverting the series. Thus let us put

$$(8) \quad w = \tan^{-1}Z = \frac{\pi}{2} + \int_{\infty}^Z \frac{dZ}{1+Z^2}.$$

For values of  $Z$  sufficiently large we can develop the function under the sign of integration in a series of decreasing powers of  $Z$  and then integrate; this gives: \*

$$(9) \quad w - \frac{\pi}{2} = \int_{\infty}^Z \left( \frac{1}{Z^2} - \frac{1}{Z^4} + \frac{1}{Z^6} - + \dots \right) dZ$$

$$= -\frac{1}{Z} + \frac{1}{3Z^3} - \frac{1}{5Z^5} + - + \dots$$

On inverting this series we obtain  $1/Z$  represented by a series of powers of  $w - \pi/2$  with positive integral exponents, the first term being

$$(10) \quad -\left(w - \frac{\pi}{2}\right).$$

By division of series (A. A. § 77) we obtain then a development for  $Z$  in powers of  $w - \frac{\pi}{2}$  with increasing integral exponents; the first term is

$$(11) \quad \frac{-1}{w - \frac{\pi}{2}}.$$

We thus have the theorem:

VII. *The inverse of the function  $\tan^{-1} Z$  has as simple poles the point  $w = \frac{\pi}{2}$  and the points*

$$(12) \quad w = \frac{(2k + 1)\pi}{2},$$

*where  $k$  is an arbitrary integer; at each of these points its residue is equal to  $-1$ .*

\* We notice that this development does not give the principal value of  $\tan^{-1} Z$  for all values of  $Z$  for which it converges, but for only those values whose real part is positive.

All these properties of the function inverse to  $\tan^{-1} Z$  belong also to the function

$$(13) \quad \tan w = \cot\left(\frac{\pi}{2} - w\right),$$

as is easily shown from the properties of the cotangent function discussed in § 52. As a matter of fact, we have already noticed in § 53 that the integral (5) represents the inverse of the function  $\tan w$ . But it is important, especially in considering complicated cases, to know directly that *all* solutions of the equation  $\tan w = Z$  can be represented by means of the integral (5) when the corresponding path of integration is entirely arbitrary.

Moreover, the equation

$$(14) \quad \tan^{-1} Z = \frac{1}{2i} \log \frac{1+iZ}{1-iZ} \text{ or } \log z = 2i \tan^{-1} \left( \frac{i-iz}{1+z} \right)$$

is entirely in harmony with the EULERIAN relations II, § 40; in fact, if we put

$$(15) \quad Z = \tan w$$

we obtain :

$$(16) \quad \frac{1}{2i} \log \frac{1+iZ}{1-iZ} = \frac{1}{2i} \log \frac{\cos w + i \sin w}{\cos w - i \sin w} = \frac{1}{2i} \log e^{2iw} = w$$

as it should be.

### § 58. The Square Root

By means of the logarithmic function we can now answer the question mentioned at the end of the first chapter about the meaning of the roots of complex numbers; that is, about the inverse of the function  $z^n$  investigated in § 18. To be sure, Theorems III and IX of § 18 would suffice to answer this question; but we notice that these theorems were obtained only by representing a complex number in terms of its absolute value and amplitude, and this is equivalent with the determination of the logarithm, in so far as we are concerned with the essential point

of the question, viz. the many-valuedness. Of course we can also derive those theorems purely algebraically if we assume the fundamental theorem of algebra ; but this is much less direct.\* In general an algebraic function is not necessarily simpler in itself than a transcendental function. With the aid of the logarithmic and exponential functions, we now study in this paragraph the function "square root" as the simplest example of how to obtain an insight into the nature of the algebraic dependence between two variables, by representing both of them as single-valued, transcendental functions of an auxiliary variable.

Definition :

I. *The square root of a complex number  $z$ ,*

$$(1) \quad s = \sqrt{z},$$

*is a complex number  $s$  which satisfies the equation :*

$$(2) \quad s^2 = z.$$

If we introduce an auxiliary variable  $\eta$  by the relation :

$$(3) \quad z = e^\eta,$$

that is, if we put  $\eta$  equal to one of the values of the function  $\log z$ , already discussed in § 56,  $s$  is also expressible as a single-valued function of  $\eta$  as follows. Since equation (2) is to be preserved, any value of the logarithm of one side must be equal to a value of the logarithm of the other side ; hence it follows that

$$(4) \quad \eta = \text{one of the values of } \log (s^2).$$

But these values separate (VIII, § 56) into two classes : the values of one class are equal to  $2 \log s$ , the others differ from these by uneven multiples of  $2 \pi i$ . It then follows that every

\* Cf., for example, H. WEBER, *Lehrbuch der Algebra* (Braunschweig, 1895), Vol. 1, page 107.

value of  $\log z$  must be representable either in the form :

$$\frac{\eta}{2} + k 2\pi i, \quad k = 0, \pm 1, \pm 2, \dots$$

or in the form :

$$\frac{\eta}{2} + \frac{2k+1}{2} 2\pi i, \quad k = 0, \pm 1, \pm 2, \dots$$

Both of these are represented in the one form :

$$\frac{\eta}{2} + k\pi i, \quad k = 0, \pm 1, \pm 2, \dots$$

We thus obtain the following result :

II. *If the given value of  $z$  be put in the form (3), then every value of  $s$  belonging to it is representable in the form*

$$(5) \quad s = e^{\frac{\eta}{2} + k\pi i}$$

*in which  $k$  is any integer.*

Conversely, it follows from the equations (I1), (I2) of § 40 :

III. *However the integer  $k$  in (5) may be chosen, this formula always gives a value of  $s$  which satisfies equation (2), and therefore, according to the definition, is a value of  $\sqrt{z}$ .*

This is also expressible in another manner. We understood  $\eta$  above to be a definite one of the values of  $\log z$ ; all the others are then of the form  $\eta + 2k\pi i$  where  $k$  is an integer. We therefore obtain all the values (5) directly, if  $\eta$  in

$$(6) \quad s = e^{\frac{\eta}{2}} = e^{\frac{1}{2} \log z}$$

is now understood to be any arbitrary, not a fixed value of  $\log z$ . Accordingly we may state theorems II and III as follows :

IV. We obtain all the pairs of corresponding values  $s$ ,  $z$  which satisfy equation (2) if we put

$$(7) \quad s = e^{\frac{\eta}{2}}, \quad z = e^{\eta}$$

and regard  $\eta$  as the independent variable.

V. If we take the principal value for  $\log z$  in (6), we obtain a definite value of  $s$ ; we call it the principal value of the square root. Its characteristic property is that its amplitude  $\psi$  satisfies the conditions

$$(8) \quad -\frac{\pi}{2} < \psi \leq \frac{\pi}{2};$$

in other words, that its real part is not negative.\*

Since the logarithm is an infinitely many-valued function, it might appear from (6) that the square root could also have an infinite number of values. But that is not the case. All the values of the logarithm follow from the principal value by the addition of  $2k\pi i$  where  $k$  is an arbitrary integer. If this integer be even, we obtain from (6) the same value  $s = s_0$  as when the principal value of the logarithm is used; if it be uneven, we obtain  $s = s_0 \cdot e^{\pi i} = -s_0$ . It follows accordingly that for the square root there is only one value beside the principal value; or:

VI. To every value (different from 0 and  $\infty$ ) of the complex number  $z$ , there belong two and only two values of  $s$  which satisfy equation (2).

### § 59. The RIEMANN'S Surface for the Square Root

In order to make the square root a single-valued function of position on a surface, we do not need, according to the last theorem, the infinitely many-sheeted helicoid surface upon which the logarithm is represented, but it is sufficient to use a

\* If the real part of the square root is zero, then the positive imaginary value is the principal value.

*two-sheeted surface* arising from two circuits on the helicoid (Fig. 28). In this connection we notice that the "second value" of the logarithm (in the sense of definition IV, § 54) again furnishes the principal value of the square root. Thus at the place on the surface of the logarithm where the second sheet is joined to the third, the first sheet in the surface representing the square root is joined to the second, provided that to every continuous connection between the values of the function there

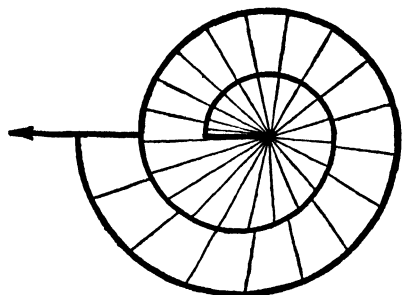

FIG. 28

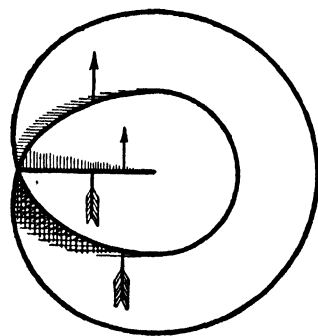

FIG. 29

shall correspond a continuous connection between the parts of the surface. But this cannot be represented otherwise in space than to allow the generating border of the second sheet to pierce the part of the surface lying under it, in order that it may return to its initial position in the first sheet which lies under the second, thus uniting the two sheets (Fig. 29).

The form of such a surface is most easily obtained by constructing it step by step. Let us think of a radius in the plane unlimited in length and beginning at the origin which, starting from a definite initial position (say  $\phi = -\pi$ ), turns about the origin in the positive sense and by such a movement describes part of a surface. When this radius has returned to its initial position after one revolution, the surface thus generated has

two borders lying adjacent to each other. But these are not yet to be united with each other; on the contrary, let the moving boundary be pushed beyond the fixed one, and let the turning movement continue over the first sheet in the same sense as before and so that the part of the surface thus continually generated trails behind this moving radius. When this moving boundary completes a second revolution, it is allowed to pierce the surface lying under it and to be combined with the initial boundary lying still deeper.

Figure 30 represents a section of the surface made by a plane perpendicular to the half-axis of negative real numbers. It shows how the left part of the first sheet is bridged or connected along this negative axis with the right part of the second sheet, and how the right part of the first is bridged to the left part of the second.

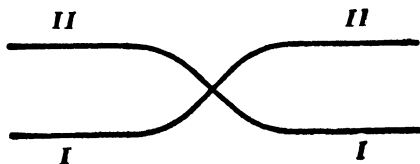

FIG. 30

The point  $z = 0$ , about which the sheets are regarded as hanging together so that we must change from one sheet to the other in making a circuit about this point, is called a *branch-point* of the surface (cf. II, § 55); it is in fact a simple branch-point, or one of the first order. In the same way the point  $\infty$  is a simple branch-point. The lines along which the two sheets pierce each other are called *bridges* (or simply cuts or *branch-cuts*).\*

\* In Fig. 30 we referred to the sheets of the surface as having a bridge between them. What is thus called (provisionally) the bridge between the sheets will serve as a cut in the  $z$ -plane to determine two branches of the function; in this case the branches are assigned to the upper and lower sheets respectively. And, conversely, when a cut has been employed to locate branches, it is often convenient to use that cut as a bridge on the RIEMANN'S surface and to call it a *branch-cut*. Thus in the case above when  $\sqrt{z}$  and  $-\sqrt{z}$  are the two branches the axis of negative real numbers is a branch-cut for the corresponding RIEMANN'S surface.  
—S. E. R.

*Therefore upon this surface the square root is a single-valued function of position; not only a definite value of  $z$  but also a definite value of  $s = \sqrt{z}$  is assigned to each of its points. Hence  $s$  is also a continuous function of position on this surface; if a point, progressing continuously, takes on all the values on a closed curve on the surface itself (not merely on its projection on the  $z$ -plane), then the corresponding values of the square root also change continuously. Conversely, only ONE point of the surface corresponds to each pair of values  $(z, s)$ , which satisfies equation (2), § 58. In order that this may be true without exception we stipulate further; the branch-point is counted as only one point of the surface corresponding to the pair of values  $(0, 0)$ . But every other point of the bridge or branch-cut represents two points of the surface, one of which belongs to one part, the other to the other part, of the surface divided at this cut.*

It is important that we have a clear notion of what is essential and what is not essential in this geometrical representation of the connection between the values of the function by means of the RIEMANN'S surface. The branch-points  $z = 0$  and  $z = \infty$  are essential; to change them would mean to change the function  $s = \sqrt{z}$  to some other function, not merely to give another form to the geometrical picture. On the other hand, the form of the branch-cut is entirely unessential; it must only connect the points  $0$  and  $\infty$ . That it coincides with the axis of negative real numbers is only a consequence of the manner in which we defined the principal value of the amplitude, and thereby of the logarithm in I, § 54. We might make some other arbitrary assumption in order to define a first sheet of our surface. Such an assumption is formulated geometrically as follows: Let us draw a definite line from  $0$  to  $\infty$  not intersecting itself; then let us choose for a definite point  $z_0$ , not lying upon this line, one of the two values belonging to  $s$ , say  $s_0$ , and take at any other

point  $z_1$  that value for  $s$  which is obtained when a  $z$ -path is drawn from  $z_0$  not intersecting the line and when in this way  $s$  changes continuously from  $s_0$ . Let us then take two such sheets and connect them crosswise along the cut. We thus obtain a surface upon which  $\sqrt{z}$  is a single-valued and continuous function of position.

If we wish to take into account in this geometrical representation the arbitrary manner of choosing the cut, we must regard the sheets as movable over each other in such a way that the cut can be shifted without breaking the connectivity. To be sure this supposes that the one sheet is partially shoved through the other without tearing them (that is, if the old cut be  $V$  and the new one be  $V'$ , the part of the lower sheet between  $V$  and  $V'$  becomes part of the upper sheet, and *vice versa*);\* but there is no necessity whatever of ascribing the property of impenetrability to the sheets, since they are only geometrical and not physical creations. In general, this cut is only a necessary makeshift; a continuous transition from one value of the function to the other belonging to the same value of the argument, does not take place at the cut just as it does not at other places on the surface (with the exception of the branch-points). In the application of this idea it is convenient to make the following stipulations — and, in fact, once for all, since we shall frequently be concerned with similar relations :

*It is assumed that there is no connection along a line between two parts of a surface which is divided by such a line. A point which moves upon a surface of this kind must, when it comes to such a line (or cut), never cross the cut to the other part of the surface.*

(In Fig. 30 the left half of the lower and the right half of the upper "sheet" represents the one part, the right half of the lower and the left half of the upper represent the other one of the two "parts of the surface," mention of which has just been made in the above statement.)

\* The sentence in parenthesis inserted by the translator.

## EXAMPLES

1. For the function  $s = \sqrt{z}$  put  $z = r(\cos \phi + i \sin \phi)$ ; that is,  $s = \sqrt{r} \left( \cos \frac{\phi}{2} + i \sin \frac{\phi}{2} \right)$  (where  $r$  may be put equal to 1) and construct a table of corresponding values of  $\phi$ ,  $z$ , and  $s$  using for this purpose  $\phi = 0, \frac{\pi}{2}, \pi$ , etc.; show in this way that the values of  $s$  will not *repeat* until  $\phi$  makes two circuits about the origin.

That  $z = 0$  is here a branch-point is shown by describing closed paths around it. (Cf. footnote following II, § 55.) Let the variable start from the point  $z = 1$  and describe a circle about the origin; let the function  $s = \sqrt{z}$  start from the point  $z = 1$  with the value  $s = +1$  and thus  $r = 1, \phi = 0$ . As  $z$  now describes a circle in the positive direction,  $r$  remains  $= 1$  and  $\phi$  increases from 0 to  $2\pi$ . When the variable has returned to  $z = +1$ , we have

$$z = \cos 2\pi + i \sin 2\pi,$$

and hence

$$s = \sqrt{z} = \cos \pi + i \sin \pi = -1;$$

the function has now not the original value  $+1$ , but the other value  $-1$ . The same thing takes place when the variable starting from  $z = 1$  describes any other closed path around the origin, since this path can be gradually deformed into the circle without thereby passing through the origin.

And, in general, if  $s$  start with the value  $s_0$  at any point  $z_0$  at which

$$z_0 = r_0(\cos \phi_0 + i \sin \phi_0)$$

$$s_0 = r_0^{1/2}(\cos \frac{1}{2} \phi_0 + i \sin \frac{1}{2} \phi_0),$$

and if  $z$  describe a closed path around the origin once in the positive direction, then, on returning to  $z_0$ , we have

$$z = r_0[\cos(\phi_0 + 2\pi) + i \sin(\phi_0 + 2\pi)]$$

and hence

$$\begin{aligned} s &= r_0^{1/2}[\cos(\frac{1}{2} \phi_0 + \pi) + i \sin(\frac{1}{2} \phi_0 + \pi)] \\ &= -s_0. \end{aligned}$$

If the variable describe the closed path twice, or any other closed path around the origin twice, then the amplitude of  $z$  increases by  $4\pi$ , that of  $s$  by  $2\pi$ , and hence the function again takes on its original value.

2. Show by means of the transformation

$$z = \frac{1}{t}$$

that  $z = \infty, t = 0$  is a branch-point for  $s = \sqrt{z}$ .

3. A case very similar to that of Ex. 1 is the function

$$s = (z - 1)\sqrt{z}.$$

Here  $z = 0$ , but not  $z = 1$  is a branch-point. For, let us consider the point  $z = 1$  for which  $s = 0$ , and let  $z$  describe around it a circle with radius  $r$ , starting at  $c = 1 + r$  on the real axis (cf. Fig.). If we put

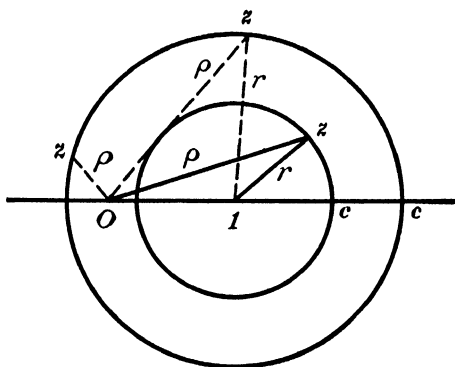

$$z - 1 = r(\cos \phi + i \sin \phi),$$

then  $s = r(\cos \phi + i \sin \phi)\sqrt{1 + r \cos \phi + ri \sin \phi}$ .

As  $r$  remains constant and  $\phi$  increases from 0 to  $2\pi$  the factor  $r(\cos \phi + i \sin \phi)$  does not change its value. To study the behavior of the second factor, let us put

$$\begin{aligned} 1 + r \cos \phi &= \rho \cos \psi \\ r \sin \phi &= \rho \sin \psi; \end{aligned}$$

thus  $\rho$  is the straight line  $oz$  and  $\psi$  the angle it makes with the real axis, and we have

$$s = r(\cos \phi + i \sin \phi)\rho^{\frac{1}{2}}(\cos \frac{1}{2}\psi + i \sin \frac{1}{2}\psi).$$

Therefore, if the circle does not inclose the origin,  $\psi$  passes through a series of values beginning with 0 and ending with 0, and hence  $s$  does not change its value. But if the circle be so large that the origin also lies within it,  $\psi$  increases from 0 to  $2\pi$ , and hence in this case the original value  $s = r\rho^{\frac{1}{2}}$  passes into  $-r\rho^{\frac{1}{2}}$ . We thus confirm the statement that only the point  $z = 0$  and not the point  $z = 1$  is a branch-point.

4. It is sometimes desirable to consider the function  $(z-1)\sqrt{z}$  of the previous example as derived from

$$s' = \sqrt{(z-1)(z-a)}z$$

by making  $a = 1$ . A line inclosing the point  $z = 1$  can then be regarded as having at first inclosed the two points  $z = 1$  and  $z = a$  which were subsequently made to coincide. Now  $z = 1$ ,  $z = a$ , and  $z = 0$  are all branch-points of the function  $s'$ . A closed path which, starting from  $z_0$ , makes a circuit around both points 1 and  $a$ , can be replaced by closed paths, each of which incloses only one of these points. And if  $s'$  start from  $z_0$  with the value  $s'_0$ , on encircling the point  $a$  it passes into  $-s'_0$ , and then on encircling the point 1,  $-s'_0$  passes into  $s'_0$  again. The function returns therefore to  $z_0$  with its original value. This is true as  $a$  approaches the point 1, and when these branch-points coincide the common point obviously ceases to be a branch-point.

5. Discuss next the function

$$s = \sqrt{\frac{z-a}{z-b}}, \quad a, b \text{ complex.}$$

Here  $z = a$  and  $z = b$  are both branch-points. For, if we first let  $z$  describe a closed path around the point  $a$  starting from any point  $z_0$  say, but not inclosing the point  $b$ , and if we accordingly put

$$\begin{aligned} z - a &= r(\cos \phi + i \sin \phi), \\ z_0 - a &= r_0(\cos \phi_0 + i \sin \phi_0), \end{aligned}$$

then the initial value of  $s$ , denoted here by  $s_1$ , is

$$s_1 = \frac{r_0^{\frac{1}{3}}(\cos \frac{1}{3} \phi_0 + i \sin \frac{1}{3} \phi_0)}{[a - b + r_0(\cos \phi_0 + i \sin \phi_0)]^{\frac{1}{3}}}.$$

After the closed path is described once in the positive direction,  $\phi_0$  has increased by  $2\pi$  and hence the resulting value of  $s$ , denoted here by  $s_2$ , is

$$s_2 = \frac{r_0^{\frac{1}{3}}[\cos(\frac{1}{3}\phi_0 + \frac{2}{3}\pi) + i \sin(\frac{1}{3}\phi_0 + \frac{2}{3}\pi)]}{[a - b + r_0(\cos \phi_0 + i \sin \phi_0)]^{\frac{1}{3}}}.$$

Here the denominator, and therefore the quantity  $\sqrt[3]{z-b}$  cannot have changed its value because for it  $z=b$  and not  $z=a$  is a branch-point;  $z$  has thus described a closed path which does not include the branch-point of this expression. Let

$$\alpha = \cos \frac{2}{3}\pi + i \sin \frac{2}{3}\pi = \frac{-1 + i\sqrt{3}}{2}$$

be a root of the equation  $\alpha^3 = 1$ ; then, since

$$\begin{aligned} \cos(\frac{1}{3}\phi_0 + \frac{2}{3}\pi) + i \sin(\frac{1}{3}\phi_0 + \frac{2}{3}\pi) &= (\cos \frac{1}{3}\phi_0 + i \sin \frac{1}{3}\phi_0) \\ &\quad (\cos \frac{2}{3}\pi + i \sin \frac{2}{3}\pi), \end{aligned}$$

we can write

$$s_2 = \alpha s_1.$$

Now let  $z$  describe a second closed path around the point  $a$ ; then  $s$  starts at  $z_0$  with the value  $s_2 = \alpha s_1$  and acquires after completing the circuit the value

$$s_3 = \alpha s_2 = \alpha^2 s_1.$$

After a third circuit  $s$  acquires the value  $\alpha^3 s_1$ ; that is, the original value  $s_1$  since  $\alpha^3 = 1$ . If we had started from  $z_0$  with the value  $s_2$  instead of  $s_1$ , we should have obtained  $s_3$  and  $s_1$  after one and two circuits respectively; and if  $s_3$  had been the original value, it would have changed into  $s_1$  and  $s_2$  successively.

Show now that similar results are obtained when  $z$  is made to describe a closed path including only the point  $b$ ; and further

that repeated circuits around a branch-point interchange the function-values in cyclical order.

Discuss also what takes place when  $z$  describes a closed path including both points  $a$  and  $b$ .

### § 60. Connectivity of this Surface

One frequently encounters the problem to apply the general theorems of Chapter IV concerning single-valued functions of  $z$  to such functions which are single-valued functions of position on any RIEMANN'S surface other than the plane, or the sphere. Now those theorems depend upon the fundamental theorem of integration in § 36 due to CAUCHY, and this again depends upon the substitution of an integral taken along a closed curve for a sum of integrals taken around sufficiently small regions of the surface. If, therefore, these theorems are to be applied to any other surface, we must first determine whether any closed curve on this surface also completely bounds a region of the surface; we shall see that this is by no means the case for all surfaces.

The problem is, as we see, a *qualitative* one; it has nothing to do with comparing the dimensions of the surfaces, but is to be answered in the same manner for all surfaces which can be transformed into each other by continuous deformation (stretching and bending) without tearing. It thus belongs to a chapter in geometry which is customarily called *analysis situs* or *topology*, and which in general treats of those properties of geometrical forms common to all forms which can be transformed into each other by stretching and bending without tearing. Moreover, in the treatment of this question the geometrical forms may be supposed to be penetrable or to be impenetrable. But according to previous assumptions it is quite necessary for our purpose to regard them as impene-

rable. We can then deform\* our surface into a sphere in the following manner:

Let us first draw out the inner sheet further through the branch-cut (Fig. 31 *a*). This process is continued until the

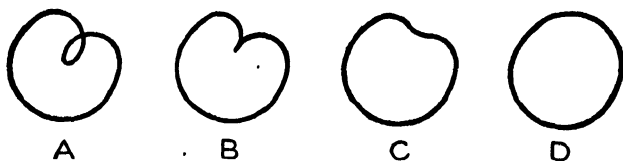

FIG. 31

entire inner spherical sac is drawn out; a sharp edge (*b*) now appears at the place at which the cut had been made. Let us next smooth this off (*c*) and the sphere (*d*) is the final result.

We can also arrange this deformation process somewhat differently. We can think of the inner sphere as flattened out more and more until it finally becomes a doubly covered circular flat disc. It is then evident that, by pulling the two sheets of this disc through each other, a sphere with a pocket sunk in it results (Fig. 32 *b*). If this pocket be gradually flattened out, we obtain finally a sphere.

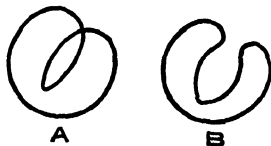

FIG. 32

The question as to the possibility of a *continuous* deformation of one surface into another need not be emphasized

here. After all, two surfaces are equivalent for the present investigation merely when they are so related that a continuous path on one surface corresponds in the deformation to a continuous path on the other. For then every closed line on the one surface which completely bounds a part of the surface, corre-

\* A large number of figures explaining such processes of deformation are to be found in the work by FR. HOFMANN, *Methodik der stetigen Deformation zweiblättriger RIEMANN'SCHER Fläche*, Halle, 1888.

sponds on the other to a closed line with the same property (otherwise a continuous path on the one surface, which connects two points on opposite sides of this closed line, could not correspond to a continuous path on the second surface, contrary to the hypothesis). But such a correspondence between two surfaces is obtained also as follows :

Let us divide the given surface into any number of parts, taking care that we know in what manner they are connected at the new borders. We then deform each of the parts so obtained without tearing and without uniting the parts just divided. Next lay the deformed parts side by side so that they will join in pairs with such parts of their borders as originally belonged together ; and finally unite these borders.

In the case under discussion the deformation takes place as follows : Mark the right bank (that is, the one lying on the side of positive  $y$ ) of the branch-cut in each sheet by hatching

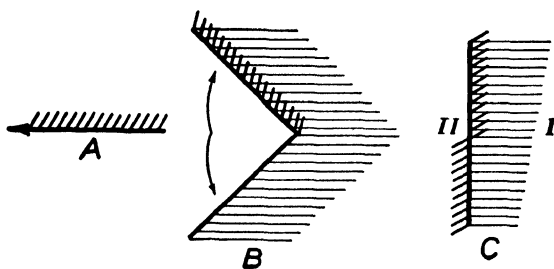

FIG. 33

(Fig. 33, A). Then make an incision along the branch-cut through both sheets, each sheet thus appearing as a sphere, or as a plane, respectively, with a cut—the latter representation being the more convenient here. By turning the two sides of the cut apart-around the origin in opposite directions, we contract the surface ; continue this way until the angle at the origin, which is  $2\pi$ , is reduced to  $\pi$ . Proceed the same way with the

other sheet. When both sheets are deformed in this way, place them in the plane close together and in such a way that the smooth bank of the cut in one sheet lies adjacent to the hatched bank of the cut in the other sheet, just as they were originally. (It can also be so arranged by suitably stretching the banks that the points of the banks that were originally side by side are exactly so placed after deformation.) Finally let us unite these banks. We obtain in this way a smooth plane, or a sphere, respectively (Fig. 33 *c*).

In accordance with all these methods of deformation, we therefore obtain the theorem :

*The two-sheeted RIEMANN'S surface with two branch-points has the same connectivity as the sphere.*

§ 60 a. Rational Functions of  $z$  and  $s = \sqrt{z}$

In the investigation of any algebraic function of  $z$ — called  $s$  for example — it is appropriate to consider at the same time all the functions which can be expressed rationally in terms of  $z$  and  $s$ . Every such function has only one definite value at any point of the RIEMANN'S surface on which  $s$  is single-valued ; this value is obtained by giving to  $s$  in the corresponding expression exactly that value which belongs to this point of the surface.

For the case  $s = \sqrt{z}$  then,  $z = s^2$  becomes a single-valued function of  $s$ ; we can therefore transform at once every rational function of  $s$  and  $z$  into a rational function of the one variable  $s$ . But when a complicated algebraic relation exists between  $z$  and  $s$ , it is not in general possible, the proof of which will not be given here, to introduce an auxiliary variable, by which  $z$  and  $s$  can both be represented as rational functions. We shall therefore make no use of the possibility of such reduction in the above simple case, but shall investigate the rational functions of  $s$  and  $z$  directly as such.

We can reduce every such function to a certain simple normal form. We can represent it for the present as the quotient of two rational integral functions of  $s$  and  $z$ , and then remove all higher powers of  $s$  occurring in numerator and denominator by means of the equations:

$$(1) \quad s^2 = z, \quad s^3 = sz, \quad s^4 = z^2, \quad s^5 = sz^2, \dots;$$

in this way, the fraction reduces to the form

$$(2) \quad \frac{g_1(z) + sg_2(z)}{g_3(z) + sg_4(z)},$$

in which the  $g$ 's are rational integral functions of  $z$  alone. Multiplying numerator and denominator by  $g_3(z) - sg_4(z)$  gives the form:

$$(3) \quad \frac{g_1g_3 - zg_2g_4 + s(g_2g_3 - g_1g_4)}{g_3^2 - zg_4^2}$$

or

$$(4) \quad r_1(z) + sr_2(z)$$

in which  $r_1$  and  $r_2$  are rational (fractional) functions of  $z$  alone. *Therefore every rational function of  $z$  and  $s$  given above may be put in this form.*

Common zeros of numerator and denominator can eventually be removed by this arrangement or new ones could be introduced; this is to be treated as in § 20.

To express the variable  $\sigma$  as a rational function of  $z$  and  $s$ , we write:

$$(5) \quad \sigma = R(z, s).$$

Then the value of the function  $R(z, s)$  belongs to one of the two points which lie on the RIEMANN'S surface over a point  $z$  of the plane, and the value of the function  $R(z, -s)$  belongs to the other one of the two points, provided that a definite one of the two values of  $\sqrt{z}$  corresponding to a given  $z$  is denoted by  $s$ .

However, this symbolism is somewhat tedious, and on this account we frequently write simply  $\sigma = f(z)$ , and agree that the symbol  $z$  is always to designate a definite point of the surface, no matter which of the two points it is that corresponds to the same value of the complex variable  $z$ . The other one could then be designated by  $\bar{z}$  say (different from the meaning of this symbol as used in § 111).

Conversely, if a function of a complex variable  $z$  be so defined that the two values of this function belong to each value of  $z$ , and that these values are so arranged on the two sheets of our two-sheeted RIEMANN'S surface that only one of these values belongs to each point of the surface, and that in this way values of the function differing by an indefinitely small amount correspond to points of the surface indefinitely near each other, then we call such a function single-valued on the RIEMANN'S surface. But not every function single-valued on our RIEMANN'S surface is a rational function of  $s$  and  $z$ ; this is as improbable as that every single-valued function of  $z$  alone is a rational function of  $z$ . In § 44 we became acquainted with functions of  $z$  alone by means of which we could determine whether or not a given function is a rational function of  $z$ : we could draw conclusions about the nature of the function in general from its behavior in the neighborhood of any individual point. This was possible on account of the fundamental theorems on integration due to CAUCHY; to obtain corresponding theorems for the functions on a RIEMANN'S surface, we must apply those theorems of CAUCHY to functions which are first defined to be single-valued, not in the  $z$ -plane but on such a surface.

### § 61. Application of CAUCHY'S Theorems to Functions which are single-valued on the RIEMANN'S Surface for $\sqrt{z}$

To properly attack this problem we must be clear at the start as to the meaning of such terms as regular, pole, essential

singularity when applied to this surface; this is necessary, since the former definitions of these terms apply only to functions which are single-valued on the  $z$ -plane itself.

No difficulty whatever presents itself in a domain of the surface which contains no branch-point. Every such domain can be constructed from parts of the surface each of which lies entirely in one sheet of the surface; we can then apply the former definitions and theorems directly to each such part of the surface.

It is different in the neighborhood of a branch-point: the former definitions do not apply to such a point. But we can map the neighborhood of the branch-point reversely and uniquely upon the neighborhood of the origin of an auxiliary plane by the substitution \*

$$(1) \quad z = t^2, \quad dz = 2t \, dt,$$

and then study in this plane all the functions to be investigated. It is therefore essential to so determine all definitions that they depend upon the former definitions for their meaning in the auxiliary plane. Accordingly, we define:

I. *A function  $f(z)$  of  $z$  is called "regular on the RIEMANN'S surface" in the neighborhood of the branch-point  $O$ , when it is transformed by the substitution (1) into a function  $\phi(t)$  of the auxiliary variable  $t$ , which is regular in the neighborhood of the origin of the  $t$ -plane in the sense of the former definition.*

\* Since the inverse of the function  $s = \sqrt{z}$ , by which we have defined this RIEMANN'S surface, is a single-valued function of  $s$ , we could use this  $s$  itself as an auxiliary variable *here* and thus obtain a single-valued representation on the  $t$ -plane not only of the neighborhood of the branch-point but also of the entire surface. But since it is not in general possible, as we have seen in § 60 a, to find an auxiliary variable having this property for complicated algebraic functions, we must be satisfied with mapping the neighborhood of the branch-point and then use a particular auxiliary variable for each branch-point.

In this connection it is to be noticed that it is not true that a function, regular only upon the surface and not at the same time in the  $z$ -plane, has everywhere a definite, finite derivative with respect to  $z$ . An example is the function  $s = \sqrt{z}$ ; its derivative:

$$(2) \quad \frac{ds}{dz} = \frac{1}{2\sqrt{z}}$$

is not finite for  $z = 0$ .

If, in the further study with substitution (1), we obtain a function of  $t$  which is regular at all points of a certain neighborhood of the origin, this point itself excepted, we define:

II. *According as this function of  $t$  has a pole (non-essential singularity) or an essential singularity at the point  $t = 0$ , we say that the branch-point is a pole or an essential singularity for the assigned function.*

And further:

III. *In the case of a pole at the branch-point, the order of the infinity of the function is to be determined from  $t$  and not from  $z$ ;* thus, for example, the function  $1/z$  considered as a function of the surface has a pole of the second order at the origin.

Corresponding to this we say of a function which is regular at a branch-point, that it has a zero of the  $m$ th order at this branch-point when the function into which it is transformed by substitution (1) has a zero of the  $m$ th order at the origin. This is also expressed as follows:

IV. *In the neighborhood of a branch-point we consider  $\sqrt{z}$ , not  $z$ , as an infinitesimal of the first order.*

In accordance with the terminology thus defined, we state the following theorem:

V. *The integral*

$$(3) \quad \int f(z) dz,$$

*taken along any curve which completely bounds a part of the surface, is equal to zero when the function  $f(z)$  is regular over this part.*

For, if this part contains no branch-point within it, we can divide it into a number of pieces each of which lies entirely in one sheet of the surface. For each such piece the earlier proof is then valid; and if we subsequently unite these pieces, the integrals taken along the lines between the pieces drop out as in § 29 (Fig. 15), and only the integral taken along the given curve remains.

But when the integral is to be taken along a curve which incloses the branch-point at the origin, we map the neighborhood of the branch-point on the neighborhood of the origin of the  $t$ -plane by substitution (1); integral (3) is thus transformed into  $\int \phi(t)t dt$ . A curve which completely incloses this branch-point on the surface, is projected on the  $z$ -plane into a curve which there encircles the branch-point twice; this curve is mapped in the  $t$ -plane into a curve making just one circuit about the origin; according to hypothesis the function  $\phi(t)$ , as also the function  $t\phi(t)$  is regular inside of this curve; the integral is therefore zero in the  $t$ -plane, and this result is applicable to the given integral on the surface.

We treat the neighborhood of the branch-point at infinity in a similar manner with the aid of the substitution  $z = t^{-2}$ .

Finally, if we are considering a domain which contains one or both branch-points in its interior, we separate it in the neighborhood of the branch-points into pieces each of which lies entirely in one sheet of the surface; then the theorem holds for each of these separate pieces, and on combining the integrals those taken along the paths between the pieces again disappear.

Moreover, in passing from CAUCHY'S theorem on integration to the expansion in series according to the CAUCHY-TAYLOR

theorem, we encounter no difficulty whatever if we remain away from the branch-points. In particular, when  $a$  is a value different from 0 and  $\infty$ , the binomial expansion

$$(4) \quad \sqrt{z} = \sqrt{a} \left\{ 1 + \frac{1}{2} \left( \frac{z-a}{a} \right) - \frac{1}{8} \left( \frac{z-a}{a} \right)^2 + \frac{1}{16} \left( \frac{z-a}{a} \right)^3 - + \dots \right\}$$

converges, providing  $z$  remains inside of a circle which goes through the branch-point; or, analytically, if (cf. Fig. 34)

$$(5) \quad |z - a| < |a|$$

(cf. the corresponding theorem for real variables, A. A. § 70). In fact, this expansion gives the one or the other branch of the function according as the factor  $\sqrt{a}$  standing in front of the brackets takes the one or the other value (only single-valued functions of  $z$  itself are inside of the brackets).\*

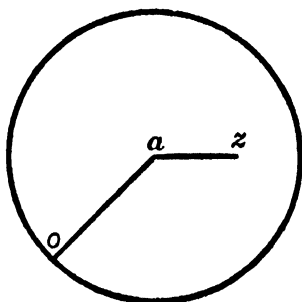

FIG. 34

But to apply the former conclusions to the integral

$$(6) \quad \frac{1}{2\pi i} \int \frac{f(z) dz}{z - \zeta},$$

taken along a circle of radius  $r$  encircling the branch-point twice, understanding that  $\zeta$  is here a quantity whose absolute value is smaller than  $r$ , we must observe that inside of the domain which is bounded by the curve of integration, the function to be integrated now becomes infinite not in one point but in two; viz., in the two points  $\zeta$  and  $\bar{\zeta}$  of the surface which lie one

\* We are not to conclude that series (4) must always furnish the principal value of  $z$  when we use the principal value of  $\sqrt{a}$ . That is the case only when the straight line connecting  $a$  and  $z$  does not cross the half-axis of negative real numbers.

above the other and belong to the same value of the argument. Accordingly, that integral—and the series obtained by expanding it in powers of  $\zeta$ —does not furnish either one of the two values  $f(\zeta)$  and  $f(\bar{\zeta})$  which the function  $f(z)$  takes on at these two points, but their sum  $f(\zeta) + f(\bar{\zeta})$ . To expand the one or the other of these two values in the neighborhood of the branch-point, we introduce the substitution (1); instead of integral (6) we then investigate the integral

$$(7) \quad \frac{1}{2\pi i} \int \frac{\phi(t) dt}{t - \tau},$$

in which  $\tau$  is to be understood as that value of  $t$  which corresponds to  $z = \zeta$ . In this way we obtain the expansion of  $\phi(\tau)$  in powers of  $\tau$  with positive integral exponents; if we then express  $\tau$  in terms of  $\zeta$  and again write  $z$  for  $\zeta$ , we obtain the theorem:

VI. *A function regular in the neighborhood of the branch-point  $z = 0$  on the RIEMANN'S surface for  $s = \sqrt{z}$ , may be expanded for values of  $z$  sufficiently small, in a convergent series of powers of  $\sqrt{z}$  with positive integral exponents—therefore in powers of  $z$  itself with positive exponents which are integral multiples of  $1/2$ .*

Since this series is obtained by substituting  $\sqrt{z}$  for  $t$  in the series first obtained, it is evident that the same value of the root is to be used in all of its terms; that is, we are to understand  $\frac{m}{z^2}$  to be the  $m$ th power of that value of  $\sqrt{z}$  which we have selected. According as the one or the other of the two values of  $\sqrt{z}$  is taken, we obtain then the corresponding one of the two values of the function at the points which are situated in the two sheets of the surface, one vertically over the other, and which belong to the same value of  $z$ .

The domain of convergence of this series is always bounded by

a circle; for, a circle about the origin in the  $t$ -plane is mapped by substitution (1) into a circle about the origin in the  $z$ -plane.

In the same way, LAURENT'S theorem (§ 47) is applicable to functions which are regular on this surface in the neighborhood of a branch-point, this point itself excepted. We obtain series arranged according to powers of  $\sqrt{z}$  with positive and negative integral exponents. According as the function has a pole or an essential singularity at a branch-point, its expansion contains a finite or an infinite number of terms with negative exponents.

Conclusions entirely analogous to these are valid for the neighborhood of the branch-point of this surface lying at infinity. We can map it upon the neighborhood of the origin of a simple auxiliary plane by the substitution:

$$(8) \quad z = \frac{1}{t^2}, \quad dz = -\frac{2}{t^3} dt;$$

and we then regard  $t$  as a suitable infinitesimal of the first order by which the order of the zero or the infinity of other functions is measured. In this way  $z$  itself is an infinity of the second order at infinity.

And Theorem XIII of § 46 is also valid for every curve which completely bounds a domain of this two-sheeted surface, inside of which the function  $u + iv$  is regular on the surface. Accordingly the second proof of Theorem IV of § 44, which follows Theorem XIII, § 46, is also valid for this surface, and hence the theorem:

VII. *A function everywhere regular on this two-sheeted surface is necessarily a constant.*

To apply further the conclusions by which we obtained Theorems V and VI from IV in § 44, we would first try to form functions which are regular everywhere on the surface, with the

exception of a single pole, for which the terms with negative exponents in the expansion in series valid for its neighborhood would be preassigned. As a matter of fact, this is possible for the surface we are considering but is not possible for the surfaces determined by more complicated irrationalities; in the application here we therefore introduce another method which is suitable for arbitrary irrationalities.

For this purpose we consider the sum

$$(9) \quad f(z) + f(\bar{z}),$$

in which we make use of a symbol already introduced (§ 60 *a*) and where  $f(z)$ , the function to be investigated, is single-valued on our surface. But while this sum is single-valued on our RIEMANN'S surface, we can prove that it must also be single-valued in the plane. For, if we allow  $z$  to describe a closed path in the plane, for which there is also a corresponding closed path on the surface, then the point  $z$  on the surface returns to  $z$  and the point  $\bar{z}$  to  $\bar{z}$ . But if we allow the point  $z$  to describe a closed path only in the plane and not on the surface, then  $z$  does not return to  $z$  but just to  $\bar{z}$ . If we start on the same path with  $\bar{z}$ , we must return to  $z$ ; for, we must necessarily arrive at one of the two points  $z$  or  $\bar{z}$ : we cannot return to  $\bar{z}$  as is evident if we trace the path backwards; it cannot, therefore, lead from  $\bar{z}$  to  $z$  and to  $\bar{z}$  at the same time.

In both cases the sum (9) returns to its initial value and is therefore a single-valued function of  $z$ . As a matter of fact, in the expansion valid for the neighborhood of a branch-point, the terms with uneven powers of  $t$  disappear because these terms in the expansion of  $f(z)$  have coefficients exactly opposite to those in the expansion of  $f(\bar{z})$ .

If we suppose further that  $f(z)$  is regular except at poles, the same supposition holds for  $f(\bar{z})$ , and then also for the sum (9);

this sum is thus a rational function of  $z$  alone :

$$(10) \quad f(z) + f(\bar{z}) = r_1(z).$$

If we apply to the product  $s \cdot f(z)$  the conclusions which were here applied to the function  $f(z)$ , we obtain a second equation

$$(11) \quad s \cdot f(z) - s \cdot f(\bar{z}) = r_2(z),$$

in which  $r_2(z)$  is also a rational function of  $z$  alone. From these two equations it then follows that :

$$(12) \quad f(z) = \frac{1}{2} r_1(z) + \frac{r_2(z)}{2s}.$$

We have thus proved the theorem :

VIII. *A function which is regular on our surface except at poles is a rational function of  $z$  and  $s$ .*

To apply also the theorem on residues to regions of this two-sheeted surface, which contain branch-points in their interior, we must observe that  $f(z) dz$  is transformed by the substitution (1) not simply into  $\phi(t) dt$  but into  $2 \phi(t)t dt$ ; and by means of substitution (8) into  $-2 \phi(t)t^{-3} dt$ . It therefore follows that :

IX. *The theorem on the sum of the residues (III, § 45) is also valid for functions on this two-sheeted surface, if, in the corresponding expansion in series, we consider the double coefficient of  $t^{-2}$ , and therefore of  $z^{-1}$ , as the residue at the branch-point in the finite part of the plane, and the double coefficient of  $t^2$  with the opposite sign, and thus again of  $z^{-1}$ , as the residue at the branch-point at infinity.*

X. *But no such modifications appear if we apply Theorems IV, V, and VI of § 46 to this surface; for the substitution (1) and for the substitution (8) we have simply :*

$$(13) \quad \frac{f'(z)}{f(z)} dz = \frac{\phi'(t)}{\phi(t)} dt,$$

and we have already agreed that the order of the function at a branch-point is to be determined from the auxiliary variable.

§ 62. The Functions  $\sqrt{(z-a)/(z-b)}$  and  $\sqrt{(z-a)(z-b)}$ .

We study next the function :

$$(1) \quad s = \sqrt{(z-a)/(z-b)}.$$

We have just studied the function  $\sqrt{z}$  somewhat in detail in the last paragraphs and the discussion of this apparently more general function can be made to depend upon that of  $\sqrt{z}$  by means of the reversibly unique substitution

$$(2) \quad z' = \frac{z-a}{z-b}, \quad z = \frac{bz' - a}{z' - 1}$$

discussed in §§ 14-16. The function

$$(3) \quad s = \sqrt{z'}$$

determines a certain surface upon the  $z'$ -sphere; by means of the substitution (2) we now transform this  $z'$ -sphere together with the surface spread out over it into the  $z$ -sphere and the corresponding two-sheeted surface covering it; this latter surface is now sufficient to represent geometrically function (1) and its branches, since this function is a single-valued and continuous function of position on this surface. The branch-points  $z' = 0$  and  $z' = \infty$  of the first surface correspond to the branch-points  $z = a$  and  $z = b$  of the latter surface; the half-axis of negative real numbers according to IV, § 14, corresponds to an arc of a circle connecting these two points and passing also through the point  $z = \frac{1}{2}(a+b)$  (corresponding to  $z' = -1$ ); that is, to the straight line  $\overline{ab}$ .

The function :

$$(4) \quad \sigma = \sqrt{(z-a)(z-b)}$$

is also single-valued on the surface thus constructed; this is

evident when it is put in the form :

$$(5) \quad \sigma = (z-b)s^*$$

This form shows that  $\sigma$  is a rational function of  $z$  and  $s$ ; and conversely that :

$$(6) \quad s = \frac{\sigma}{(z-b)}$$

is a rational function of  $z$  and  $\sigma$ . This is equivalent to saying that :

I.  $\sqrt{(z-a)/(z-b)}$  and  $\sqrt{(z-a)(z-b)}$  are irrationalities of the same class.

We can, of course, construct the RIEMANN'S surface for  $\sigma$  directly without making use of  $s$ . For this purpose we start from the fact that the equation

$$(7) \quad \sqrt{z_1 \cdot z_2} = \sqrt{z_1} \cdot \sqrt{z_2}$$

is a *complete* equation between many-valued functions, in the sense explained in VII, § 56 that every value of the right-hand side is equal to a value of the left-hand side and conversely; it follows from this simply that, for given values of  $z_1$  and  $z_2$  each side has two and only two values (not the possibility that the right side has four values). Consequently the change of value of  $\sqrt{(z-a)(z-b)}$  as  $z$  varies continuously is made clearer by observing the change in value of each of the two factors  $\sqrt{z-a}$  and  $\sqrt{z-b}$ . But that is simply the question treated in §§ 58-61 only that the point  $a$  (and  $b$ ) now appears in place of the origin:  $\sqrt{z-a}$  changes its sign if  $z$  makes a circuit about the

\* The reader is already familiar with this idea in connection with integration, for it is used to reduce  $\int \sqrt{(z-a) \cdot (z-b)} dz$  to the integral of a rational function. The transformation  $\sqrt{(z-a) \cdot (z-b)} = (z-b)s$  leads to  $\int (a-b)^2 \cdot \frac{s^2}{(1-s^2)^3} ds$ .  
— S. E. R.

point  $a$ ,  $\sqrt{z-b}$  so changes if  $z$  encircles the point  $b$ . The product then changes its sign or remains unchanged according as the path of  $z$  makes a *total*\* of an odd or an even number of circuits about the points  $a$  and  $b$ . If this number is uneven, we could stop the corresponding paths by connecting  $a$  and  $b$  by a line and not allowing  $z$  to cross this line; for then it can describe only such paths which encircle one of these two points as often as the other. If therefore we make an incision in the plane along this line, a branch of the function is defined to be single-valued on the plane cut in this way; let us now take two planes (or spheres), each of which has been cut in this manner, and fasten them together crosswise along this cut. We thus obtain a RIEMANN'S surface, on which the function under consideration is a single-valued and continuous function of position—exactly the same surface which was obtained above in other ways.

(It remains to be mentioned that the point  $z = \infty$  is *not* a branch-point of the surface; to be sure, if we encircle it, each of the factors changes its sign and hence the function itself does not change its sign. The expansion of the function for the neighborhood of the point  $z = \infty$  is, in one sheet,

$$(8) \quad \sigma = z - \frac{a+b}{2} - \frac{a^2 - 2ab + b^2}{8z} + \dots;$$

in the other sheet,

$$(9) \quad \sigma = -z + \frac{a+b}{2} + \frac{a^2 - 2ab + b^2}{8z} - \dots.$$

### § 62 a. Rational Functions of $z$ and $\sigma = \sqrt{(z-a)(z-b)}$ .

By solving equation (1) of § 62 for  $z$  we obtain

$$(1) \quad z = \frac{bs^2 - a}{s^2 - 1}.$$

\* Italics by the translator.

Thus  $z$  is a rational function of  $s$ , and accordingly every rational function of  $z$  and  $s$  may be expressed here, as in § 60 a, as a rational function of  $s$  alone. It follows from equation (5), § 62, that every rational function of  $\sigma$  and  $z$  can be represented as a rational function of a single variable  $s$ , or, as we are accustomed to saying, can be "rationalized by introducing  $s$ ." But we will investigate these rational functions directly without making use of this method of reduction since it cannot be applied to complicated algebraic functions.

We can now put, as in § 60 a, every rational function of  $z$  and  $\sigma$  in the form :

$$(2) \quad R(z, \sigma) = \frac{g_0(z) + \sigma g_1(z)}{g_2(z)}$$

in which  $g_0, g_1, g_2$  signify rational integral functions of  $z$  alone; we suppose also, that  $g_0, g_1, g_2$  have no common divisor.

We wish to investigate how such a function behaves in the neighborhood of any point on the RIEMANN'S surface of  $\sigma$ . *First*, let  $z = z_0$  be an ordinary point on the surface; that is, one lying at a finite distance from the origin and not a branch-point, and  $\sigma_0$  the corresponding value of  $\sigma$ . We can then expand  $\sigma$  by the binomial theorem in the following series of powers of

$$(3) \quad t = z - z_0,$$

convergent in a sufficiently small neighborhood of  $z_0$ :

$$(4) \quad \sigma = \sigma_0 \left\{ 1 + \frac{1}{2} t \left( \frac{1}{z_0 - a} + \frac{1}{z_0 - b} \right) + \dots \right\}.$$

If we expand  $g_0(z), g_1(z), g_2(z)$  in the same way in powers of  $t$ , replace them in the expression and rearrange,  $R$  is represented as follows as the quotient of two power series :

$$(5) \quad R = \frac{\alpha_0 + \alpha_1 t + \alpha_2 t^2 + \dots}{\beta_0 + \beta_1 t + \beta_2 t^2 + \dots}.$$

The following cases present themselves :

1. If  $\beta_0 \neq 0$ ,  $R$  is a function of  $t$ , and therefore of  $z$ , regular in the neighborhood of  $t=0$ .

2. If  $\beta_0 = 0$ , but  $\alpha_0 \neq 0$ , let  $\beta_k$  be the first coefficient different from zero in the denominator. Then  $R(z, \sigma)$  is equal to  $t^{-k}$  times a function which is regular at  $t=0$ ; we say therefore that in this case the function  $R$  has a pole of the  $k$ th order at  $z = z_0$ ,  $\sigma = \sigma_0$ .

3. If  $\alpha_0$  and  $\beta_0$  are both equal to zero,  $R$  is indeterminate at  $t=0$ . But we can remove this ambiguity as in § 20 by dividing numerator and denominator by a suitable power of  $t$ ; in this way this case reduces to one of the cases (1) or (2) already discussed.

*Second*, let the point be a branch-point and we investigate the behavior of  $R$  in the neighborhood of such a point, say  $z = a$ . Put

$$(6) \quad z - a = t^2, \quad \sqrt{z - a} = t;$$

in this way the neighborhood of the branch-point in both sheets of the surface is mapped upon the simple neighborhood of the origin of the  $t$ -plane. The representation is determined whenever the sign of the root is fixed in (6) for one value of  $z$  in the given neighborhood. For two values of  $t$  which are equal but opposite in sign, there are points of the surface which lie exactly vertical to each other in the two sheets.

Then

$$(7) \quad \sigma = t \sqrt{a - b} \left\{ 1 + \frac{1}{2} \frac{t}{a - b} + \dots \right\},$$

and  $R$  is thus represented for this case also as the quotient of two power series in powers of this auxiliary variable  $t$  with integral exponents. In this connection corresponding conclusions can then be made; and, too, it is suitable, as in § 61, to deter-

mine whether a function  $R(z, \sigma)$  is regular at a branch-point when it is a regular function of  $t$  at such a point and, in other cases, to determine the order of the infinity from the exponent of  $t$  (not from the exponent of  $z - a$  itself).

*Third.* In order to investigate the behavior of  $R(z, \sigma)$  for indefinitely large values of  $z$ , let us put

$$(8) \quad z = t^{-1}.$$

This gives the two expansions (8) and (9) of § 62, corresponding to the two points of the RIEMANN'S surface at infinity; there is an expansion of  $R$  in powers of  $t$  for each of these points, and the order of the infinity is again determined from the lowest exponent of  $t$  appearing in the expansion. Thus, for example,  $z$  and  $\sigma$  become infinite of the first order in both sheets of the surface.

The result of the investigation is therefore that :

*I. A rational function of  $z$  and  $\sigma$  is regular over the entire RIEMANN'S surface of  $\sigma$  except at poles.*

(That there can be only a finite number of poles, follows from the fact that they can only, but not necessarily must, appear where  $g_2(z) = 0$ .)

The converse of Theorem I is proved as in § 61.

There is a certain interest in the question whether there are rational functions of  $z$  and  $\sigma$  which become infinite at only one point of the surface, and of the first order at this point; and further whether this point can be chosen arbitrarily. This question is answered at once by "rationalizing" the function, but we shall attack the problem directly. In order to simplify the process let us put  $a = 1, b = -1$ ; we can at once reduce the more general case to this one by means of a reversibly unique transformation of the  $z$ -plane according to II, § 15.

If we wish to find a rational function of  $z$  and  $\sigma = \sqrt{z^2 - 1}$  which has an infinity at only one finite point  $z = \alpha$  distinct

from the branch-points, and in fact, only in one sheet and only of the first order, it follows that the denominator  $g_2(z)$  in (2) can have no factors of the first degree other than  $z - \alpha$ . For, if the denominator were divisible by  $z - \beta$ , then the function  $\mathcal{R}$  for  $z = \beta$  would become infinite at one or the other of these points of the surface, provided that the numerator would not also become zero for both values of  $\sigma$ . But since  $\sigma$  does not by hypothesis become zero for  $z = \beta$ , the numerator is zero only when  $g_0(z)$  and  $g_1(z)$  are both zero for  $z = \beta$ , that is, when both are divisible by  $z - \beta$ . But, then  $g_0, g_1, g_2$  would all three have the same common divisor  $z - \beta$  contrary to hypothesis.

In the same way it can be shown that  $g_2(z)$  is not divisible by powers of  $(z - \alpha)$  higher than the first, when the function  $\mathcal{R}$  for  $z = \alpha$  does not become infinite of higher order than the first in either one of the two sheets of the surface.

We can, therefore, take  $g_2(z) = z - \alpha$ , since a constant factor can be divided out in the numerator.

For  $z = \alpha$  there are two values of  $\sigma$ ; if we call  $\sigma_\alpha$  a certain one of them,  $-\sigma_\alpha$  will be the other one. And if  $\mathcal{R}$  becomes infinite for  $(\alpha, \sigma_\alpha)$ , but not for  $(\alpha, -\sigma_\alpha)$ , then the numerator of (2) must be zero for  $(\alpha, -\sigma_\alpha)$ , and thus

$$(9) \quad g_0(\alpha) - \sigma_\alpha \cdot g_1(\alpha) = 0.$$

This is a linear homogeneous equation between the coefficients of  $g_0$  and  $g_1$ . If it is satisfied,  $\mathcal{R}$  will not become infinite at the point  $(z = \alpha, \sigma = -\sigma_\alpha)$  as is shown by a procedure similar to the one at the beginning of this section.

Finally, we must also be certain that our function remains finite at infinity in both sheets. The denominator has an infinity there of the first order; and hence we must be careful that the numerator does not become infinite of higher order. Accordingly,  $g_0 + \sigma g_1$  and  $g_0 - \sigma g_1$  must not become infinite of

higher order than the first, where  $\sigma$  represents one and  $-\sigma$  represents the other of the two expansions (8), (9), § 62. Addition and subtraction shows that  $g_0$  and  $\sigma g_1$  must not become infinite of higher order than the first and therefore  $g_1$  in general must not. That is,  $g_0$  must be a linear function of  $z$ , and  $g_1$  a constant; accordingly we put

$$(10) \quad g_0 = (Az + B)\sigma_\alpha, \quad g_1 = C.$$

Between these three constants the relation

$$(11) \quad A\alpha + B - C = 0$$

must exist on account of (9); one of these constants is expressible in terms of the other two by (11). In this way we obtain the result:

II. *Every rational function of  $z$  and  $\sigma$  which becomes infinite at only the one point ( $z = \alpha$ ,  $\sigma = \sigma_\alpha$ ) of the surface, and only of the first order at this point, has the form*

$$(12) \quad \frac{(Az + B)\sigma_\alpha + (A\alpha + B)\sigma}{z - \alpha}.$$

*Conversely, every function of this form has the required property, omitting, of course, the trivial case  $A\alpha + B = 0$ , in which it reduces to a constant.*

Further, if we wish to form a function which becomes infinite only at the branch-point  $z = -1$ , and only of the first order there, we see as in the previous case that  $g_0(z)$  must equal  $z + 1$ . But this function becomes zero of the second order at the branch-point; we must therefore make provision that the numerator becomes zero and of the first order there. This requires that  $g_0(z)$  be divisible by  $z + 1$ ; and if we consider as before the behavior of the function at infinity, we find:

III. *Every rational function of  $z$  and  $\sigma$ , which becomes infinite only at the branch-point  $z = -1$  and there only of the first order, has the form :*

$$(13) \quad \frac{A(z+1) + C\sigma}{z+1};$$

or, by using  $\sqrt{z+1}$ , it takes the form

$$(14) \quad A + C \cdot \sqrt{(z-1)/(z+1)}.$$

Finally, to form a function which becomes infinite only at infinity but there only in one sheet and only of the first order, corresponding conclusions as in the first two cases show that  $g_2(z)$  reduces to a constant, that  $g_0(z)$  is a linear function and that  $g_1z$  must also be a constant. If, therefore,  $R$  is to become infinite when we use the expansion (8), § 62 for  $\sigma$ , but not when (9), § 62 is so used, a linear equation between the constants exists.

Hence the theorem :

IV. *Every rational function of  $z$  and  $\sigma$ , which becomes infinite only at infinity and there only in one sheet and only of the first order, has the form :*

$$(15) \quad A(z + \sigma) + B.$$

Moreover, the constants at our disposal in (12), (14), (15) can be so chosen that the function under consideration becomes zero at a preassigned point. Particular interest attaches to the function

$$(16) \quad s = \sqrt{(z-1)/(z+1)},$$

which becomes zero at one branch-point and infinite at the other ; to the function

$$(17) \quad u = z + \sigma,$$

which at infinity becomes zero in one sheet and infinite in the other; and then also to the function

$$(18) \quad \lambda = \frac{1 + i\sigma}{z},$$

which at  $z = 0$  becomes zero in one sheet and infinite in the other. The first is precisely the function designated by  $s$  in § 62.

According to Theorem VI, § 46, which also holds here (cf. X, § 61), each of the functions considered has the property that it takes on in general each value on the surface once and only once. It follows from this that each of them is a single-valued analytic function of each of the others, which takes on each value once and only once. And from this it follows further that each of these functions is a linear fractional function of each of the others. For example:

$$(19) \quad u = \frac{1+s}{1-s}, \quad s = \frac{u-1}{u+1}, \quad \lambda = \frac{1-is}{1+is} = i \cdot \frac{1-iu}{1+iu}.$$

And it follows further that any function of the surface is a single-valued function of each of these auxiliary variables. We have thus returned to that starting point which was intentionally avoided at the outset.

**§ 62 b. Integrals of Rational Functions of  $z$ , and the Square Root of a Rational Integral Function of  $z$  of the Second Degree**

Since all rational functions of  $z$  and  $\sigma$  used above may be represented as rational functions of an auxiliary variable, it follows that every integral of such a function can be transformed into an integral of a rational function and therefore can be expressed in terms of rational functions and the logarithms of such functions. In this any of the functions, which were considered in the latter part of the previous paragraph and which take on

any value once and only once on the surface, can be used as auxiliary variable. In the elements of the integral calculus we prefer to use the three functions (16), (17), (18) of § 62 *a*, since they enable us to perform the processes most conveniently.

But we will also consider the application of these integrals of rational functions of  $z$  and  $\sigma$  directly to the surface. It follows from IX, § 61, that:

I. *Such an integral is a single-valued function of its upper limit, provided that the path of integration lies entirely in a simply connected part of the surface which contains no point at which the residue of the function is different from zero.*

But if the path of integration taken in the positive sense encircles such a point, a new value of the integral is obtained which is greater than the former value by  $2\pi i$  times the corresponding residue. Hence:

II. *If the path of integration for such an integral is entirely arbitrary, we obtain an infinitely many-valued function; all of its values follow from one of them by the addition of integral multiples of a certain "modulus of periodicity." Each such modulus of periodicity is equal to  $2\pi i$  times the residue of the function to be integrated.*

We now classify the integrals according to the kind and number of their points of discontinuity. In this connection we notice that: at each finite point at which the function to be integrated is finite, the integral is also finite; at each finite point which is not a branch-point and at which the function becomes infinite, the integral also becomes infinite; but at a branch-point the integral can remain finite even if the function to be integrated becomes infinite. For, from the substitution (6), § 62 *a*, we obtain

$$(1) \quad dz = 2t dt.$$

If we then use  $t$  as the variable of integration, an additional factor  $t$  is obtained under the sign of integration, and the integral remains finite provided that the infinity of the function to be integrated is not of order higher than the first. Corresponding considerations show that at an infinitely distant point, the integral remains finite when the function to be integrated becomes zero of order higher than the first.

We ask next whether there are integrals of rational functions of  $z$  and  $\sigma$  which are nowhere infinite. (Theorem IV, § 44 would not contradict this statement, since it only treats of single-valued analytic functions of  $z$ .) If  $\int R(z, \sigma) dz$  remains finite everywhere,  $R(z, \sigma)$  must

1st. Be everywhere finite, except at the branch-points where it might become infinite of the first order ;

2d. Become zero of higher order than the first at infinity in both sheets.

The product

$$(2) \quad \sigma \cdot R(z, \sigma)$$

must then be finite everywhere and zero at infinity. But from § 62 *a* it follows that there is no rational function of  $z$  and  $\sigma$  which is finite everywhere. It then follows that :

III. *There is no integral which is finite everywhere on the RIEMANN'S surface of  $\sigma = \sqrt{z^2 - 1}$ .*

We discuss next integrals which have only logarithmic discontinuities. Since the sum of the residues on the whole surface must be equal to zero (the proof of Theorem VI, § 45, is applicable here without change), such an integral must have at least two points of discontinuity ; we wish to form an integral having such discontinuities at only two ordinary points  $(z_1, \sigma_1)$  and  $(z_2, \sigma_2)$  on the surface. If  $\int R(z, \sigma) dz$  is such an integral, the function  $R$  must have the following properties :

It must be finite everywhere, except at the two given points and at the branch-points, where it may be infinite of the first order ;

It must be zero of an order higher than the first at infinity in both sheets.

The product  $\sigma\mathcal{R}$  must therefore have the following properties :

It must be finite everywhere on the finite part of the surface except at the two points  $(z_1, \sigma_1)$  and  $(z_2, \sigma_2)$  where it may be infinite of the first order ;

It must be zero at infinity.

We can represent such a function as the sum of two functions, each of which becomes infinite at one of the given points and both become zero at infinity in the same sheet ; therefore, according to (12), § 62 *a*, the function takes the form :

$$(3) \quad A \left\{ 1 - \frac{\sigma + \sigma_1}{z - z_1} \right\} + B \left\{ 1 - \frac{\sigma + \sigma_2}{z - z_2} \right\} ;$$

and the constants  $A, B$  can be so determined that the sum becomes zero at infinity in the other sheet also. We thus obtain

$$(4) \quad A \int \left\{ \frac{\sigma + \sigma_1}{z - z_1} - \frac{\sigma + \sigma_2}{z - z_2} \right\} \frac{dz}{\sigma}$$

as the desired form of an integral having only two logarithmic discontinuities.

The constant  $A$  can also be so determined that the residue at one point of discontinuity is equal to  $+1$ , at the other equal to  $-1$  ; for this purpose we must take  $A = 1/2$ .

If we then introduce as the variable of integration the function designated by  $u$  in (17), § 62 *a*, and call  $u_1$  and  $u_2$  the values which this function takes on at the two points  $(z_1, \sigma_1)$  and  $(z_2, \sigma_2)$ , we obtain :

$$(5) \quad \int \left\{ \frac{1}{u - u_1} - \frac{1}{u - u_2} \right\} du = \log \frac{u - u_1}{u - u_2} + C.$$

If we assume the two points  $(z_1, \sigma_1)$  and  $(z_2, \sigma_2)$  to be coincident and then divide by  $u_1 - u_2$ , we can obtain from (5) the following integral which becomes infinite at only one place but algebraically of the first order at this place:

$$\int \frac{du}{(u - u_1)^2} = -\frac{1}{u - u_1} + C.$$

Repetition of this process leads then to integrals which become infinite of the second, third, etc., order at a preassigned place and which have coefficients preassigned.

In this process it is assumed that the singular points are different from the branch-points and lie on the finite part of the surface; in fact, we would encounter no fundamental difficulties in a corresponding treatment of the cases thus excluded. But it is unnecessary to enter into a discussion of this point since the whole investigation can be arranged here (except for more complicated irrationalities) to depend upon rational functions at the beginning by introducing  $u$  as independent variable.

The most general integral of a rational function of  $z$  and  $\sigma$  can then be represented as a sum of integrals of the special form considered, with suitable numerical coefficients. This follows from the fact that the difference of two integrals, which become infinite in the same manner, is an integral which never becomes infinite and is therefore a constant according to III.

### § 62 c. The Function $z = w + i\sqrt{1 - w^2}$

According to the definition of the square root of a complex number, the solution of a quadratic equation with complex coefficients is found just as we obtained the solution of the quadratic equation with real coefficients in elementary algebra. Thus, for example, if we solve for  $z$  the equation discussed in § 21 a,

$$(1) \quad w = \frac{1}{2}(z + z^{-1}),$$

or

$$(2) \quad z^2 - 2zw + 1 = 0,$$

we obtain :

$$(3) \quad z = w + \sqrt{w^2 - 1}.$$

This function is complex for real values of  $w$  whose absolute value is less than 1; this is more evident by writing

$$(4) \quad z = w + i\sqrt{1 - w^2};$$

but we must keep in mind that the principal value of the square root in (3) does not also furnish the principal value of the square root in (4) for all values of  $w$ .

As a special case of the results of § 62, it follows that the RIEMANN'S surface extended over the  $w$ -plane and determined by this function, consists of two sheets which are united at the two branch-points  $w = +1$  and  $w = -1$ . We connect these two branch-points by a cut; this is, perhaps, most conveniently done by drawing the cut from both of these points along the  $w$ -axis of real numbers to infinity. The origin is, therefore, not on the cut; consequently we distinguish between the two sheets of the surface by determining what value  $w$  shall take on at the origin in each of the two sheets. Thus we name arbitrarily the first sheet that one for which  $z = i$  and  $w = 0$ , the second sheet that one for which  $z = -i$  and  $w = 0$ . The values of  $z$  at the remaining points of both sheets are obtained by proceeding continuously; that is to say, in the neighborhood of the origin the principal value of the square root in (4) will be taken in the first sheet, but the opposite value in the second sheet. But we can by no means yet conclude that this is true throughout the whole extent of both sheets.

The investigation of this function is very much simplified from the fact that its inverse is a single-valued function of  $z$  and that we have already investigated this inverse function in

detail in § 21 a. We need only to make the results thus known still clearer by employing the RIEMANN'S surface introduced in the meantime.

We notice next that real values of  $z$  correspond to the points of the branch-cut; and, in fact, to each such value of  $w$  correspond two values of  $z$ , one of which lies inside of the unit circle and the other outside of it, since the product of the roots of equation (2) is equal to 1. Only one value of  $z$  corresponds to each of the branch-points; to  $w = +1$  corresponds  $z = +1$  and for  $w = -1$ ,  $z = -1$ . Conversely, one point of the branch-cut corresponds to each real value of  $z$ . Therefore, one sheet of the surface corresponds to the positive, the other sheet to the negative,  $z$ -half-plane. But which sheet corresponds to which half-plane is not now an arbitrary arrangement, since we have already disposed of this question by giving to  $z$  the value  $+i$  at the origin in the first sheet; in this way the first sheet must correspond to the positive half-plane, and, therefore, the other sheet to the negative half-plane. And thus, too, it is determined how the two letters which are assigned to one region in Figure

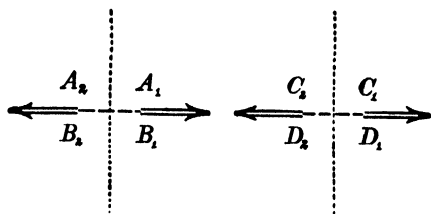

FIG. 35 a  
First sheet over the  $w$ -plane.

FIG. 35 b  
Second sheet over the  $w$ -plane.

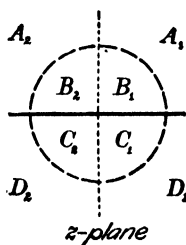

FIG. 13 e

13 h are arranged on the two sheets. Figure 13 e is repeated here in connection with the two other figures for the purpose of better comparison.

The relations in the neighborhood of the point at infinity in both sheets of the  $w$ -plane are of interest; developing the radical in decreasing powers of  $w$ , we obtain:

$$(5) \quad \sqrt{w^2 - 1} = w\sqrt{1 - 1/w^2} = \pm w \left\{ 1 - \frac{1}{2w^2} + \frac{1}{8w^4} - \dots \right\};$$

the one value of  $z$  is therefore equal to

$$(6) \quad \frac{1}{2w} - \frac{1}{8w^3} + \dots,$$

and the other value of  $z$  is equal to

$$(7) \quad 2w - \frac{1}{2w} + \frac{1}{8w^3} - \dots.$$

The first one of these values becomes zero at infinity and the other one is infinite there; as the figures show, the first development holds for that "part of the surface" (cf. end of § 59) which consists of the lower half-plane of the first sheet and the upper half-plane of the second, while the other development holds for the remaining part of the surface.

If we had made the branch-cut along the shortest line connecting the branch-points instead of along the two segments of the real  $w$ -axis external to these points, the regions  $A_1, A_2, D_1, D_2$ , would have represented the one sheet of the surface, the regions  $B_1, B_2, C_1, C_2$ , the other sheet; and therefore the one sheet would have corresponded to the inside of the unit circle of the  $z$ -plane, the other sheet to the outside of this circle.

To go further into details we would introduce in the figures the circles and straight lines, the confocal ellipses and hyperbolas which were used for a similar purpose in § 21 *a*.

According to § 62,  $z$  may be rationalized by the substitution

$$(8) \quad s = \sqrt{\frac{w-1}{w+1}};$$

we find :

$$(9) \quad z = \frac{1-s}{1+s}.$$

This is a fractional function of the first degree ; conversely,  $s$  is also expressible rationally in terms of  $z$  :

$$(10) \quad s = \frac{1-z}{1+z},$$

and  $s$  could be chosen instead of  $z$  as that function of the surface by which all other functions of the surface are expressed rationally. We find, as a matter of fact, that

$$(11) \quad \sqrt{1-w^2} = \frac{2is}{1-s^2} = i \cdot \frac{1-z^2}{2z}.$$

It is now easy to answer the question heretofore postponed concerning the region of this surface to which the principal value of the square root belongs. This region must be bounded by the line or lines along which the square root is purely imaginary. This is true along the  $z$ -axis of reals and along no other lines ; the branch-cut in the  $w$ -plane corresponds to it. Therefore the principal value is attached to the entire first sheet.

Since we have already discussed the exponential and the trigonometric functions of complex argument, the relation between  $z$  and  $w$  can now be made clear by the introduction of other auxiliary variables than the  $Z$  and  $W$  which were used in § 21 a. Thus if we put

$$(12) \quad w = \cos \eta,$$

it follows from (4) and (16), § 40, that

$$(13) \quad z = e^\eta.$$

In fact, by means of these equations the concentric circles about the origin and the rays through the origin in the  $z$ -plane

correspond respectively, according to III, § 42, to the parallels to the axes in the  $\eta$ -plane, and, according to IV, § 42, these parallels correspond to the confocal ellipses and hyperbolas in the  $w$ -plane.

#### § 62 d. The Function $\text{Sin}^{-1} w$

We wish now to define the function  $\text{sin}^{-1} w$  just as for real variables by the integral

$$(1) \quad J = \text{sin}^{-1} w = \int_0^w \frac{d\omega}{\sqrt{1 - \omega^2}};$$

to do this two additional specifications are necessary; we must make provision concerning the path of integration to be chosen and concerning the value to be given to the square root.

We specify the path of integration to be entirely arbitrary, except that it must not go through one of the branch-points since doing so would lead into difficulties. However, we need not exclude the case where the upper limit takes on one of these values, since it can be shown just as for real variables that the integral approaches in this case a definite finite limit. We must not suppose however that the value of the integral is entirely independent of the path of integration; the symbol  $\text{sin}^{-1} w$  is defined by equation (1) to be many-valued, but we will consider all the values which it takes on according to the definition as belonging to one and the same many-valued function of  $w$ .

The sign to be given the root can be fixed arbitrarily; and we agree that the value  $+1$  shall be attached to it at the lower limit of integration. But in so doing its value is fixed for the whole of the remainder of the path of integration, provided the values change continuously along the path. Any doubt concerning the value of the root could only arise when the path of integration goes through one of the points  $\omega = +1$  or  $\omega = -1$ ; but this possibility is already excluded. We determine most

simply what value of the square root obtains at any point of the path of integration, if we make use of the RIEMANN'S surface already introduced in the previous paragraphs upon which this square root is a single-valued and in general continuous function of position, and transfer the path of integration to this surface; at any point of the path we are then to take that value of the root which belongs to this point on the surface.

With the foregoing provisions we are prepared to answer the question whether integral (1) is expressible in terms of functions already introduced. As a matter of fact, it can be expressed in this way if we introduce, by means of the equations of the previous paragraph, the function  $z$  of  $w$  (and  $\zeta$  of  $\omega$ ) defined in that paragraph, as the variable of integration; it transforms accordingly into:

$$(2) \quad i \int_1^z \frac{d\zeta}{\zeta} = i(\log z - \log i) = i \log \frac{zw + i\sqrt{1-w^2}}{i} = i \log(-iz) \\ = i \log(-iz + \sqrt{1-w^2}).$$

(According to the stipulations just made we attached the value  $+1$  to the square root at the lower limit. We therefore take  $z = +i$  as the lower limit of the transformed integral, not  $z = -i$ , since only the first of these values, viz.  $z = +i$ , belongs to that one of the two points of the surface lying over the origin of the  $w$ -plane at which the square root has the value  $+1$ .)

In order, therefore, to investigate what value of the logarithm to take for a preassigned path of integration, or how, conversely, to select the path of integration to obtain a definite value of the logarithm, for example, the principal value, we must only determine how the paths in the  $z$ -plane and on the surface over the  $w$ -plane correspond to each other. But this is easily obtained from the figures of the previous paragraph.

If we limit the  $w$ -path of integration to the first sheet, that

of  $z$  remains above the real  $z$ -axis, therefore that of  $(-iz)$  to the right of the axis of pure imaginaries  $(-iz)$ , and the logarithm of  $(-iz)$  takes on its principal value. We will designate the corresponding value of the inverse sine as its principal value in the first sheet of the RIEMANN'S surface; its real part lies between  $-\pi/2$  and  $+\pi/2$ . In particular, it takes on continuously increasing the real values from  $-\pi/2$  to  $+\pi/2$ , while  $w$  continuously increasing takes on the real values from  $-1$  to  $+1$ .

Therefore crossing the part of the branch-cut lying to the right in going from  $A_1$  to  $D_1$ , or from  $B_1$  to  $C_1$ , corresponds in the  $z$ -plane to crossing the half-axis of positive reals, and therefore in the plane of  $(-iz)$  to crossing the negative half-axis of pure imaginaries  $(-iz)$ . If we then remain in the second sheet, without again crossing a cross-cut, the imaginary part of the logarithm remains between  $-\pi i/2$  and  $-3\pi i/2$ , and therefore the real part of the inverse sine between  $\pi/2$  and  $3\pi/2$ . We designate this value as the "principal value of the inverse sine in the second sheet of the RIEMANN'S surface."

Two points of the surface which are situated in the two sheets one vertically above the other, correspond to two values of  $z$  whose product is equal to  $1$ , and therefore to two values of  $(-iz)$  whose product is equal to  $-1$ . The sum of a logarithm of the first and a logarithm of the second of these values is an uneven multiple of  $\pi i$ ; the sum of the two principal values of the inverse sine is exactly equal to  $\pi$ .

But if, coming from the first sheet, we cross the part of the branch-cut lying to the left, considerations exactly parallel to the foregoing show that corresponding to this in the plane of  $(-iz)$ , we cross the positive half-axis of pure imaginaries  $(-iz)$ , and that therefore a value of the inverse sine is obtained in this way whose real part lies between the limits  $-\pi/2$  and  $-3\pi/2$ .

Let us go from the first sheet over the part of the branch-cut lying to the right into the second, and return to the first sheet over the part of the branch-cut lying to the left; corresponding to this in the plane of  $(-iz)$ , we shall then start in the half-plane lying to the right, cross the negative half-axis of pure imaginaries into the half-plane lying to the left, and from there cross the positive half-axis of pure imaginaries again into the half-plane lying to the right. But this is making a circuit about the origin in this plane in the negative sense; it necessitates an increase of the logarithm by  $-2\pi i$ , and an increase of the inverse sine by  $2\pi$ .

Such a closed curve upon the surface can be transformed by a continuous deformation into a curve which surrounds the point at infinity in one "part of the surface." In fact the residue at the point at infinity of the function of  $\omega$  to be integrated is  $+1$  in one "part" of the surface and is  $-1$  in the other "part"; the value of the integral taken along a curve which encircles the one or the other of these points in the positive sense is accordingly equal to  $\pm 2\pi i$ .

It is now possible to construct the most general path upon the surface from the processes heretofore considered and their converses. The following is therefore a résumé of the results:

*The function  $\text{sin}^{-1} w$  defined by equation (1) is an infinitely many-valued function. Its values fall into two classes corresponding to the two values of the square root. In each of these classes all the values are obtained from the principal value by the addition or subtraction of arbitrary integral multiples of  $2\pi$ . The relation between the principal value of the first class and the principal value of the second class is that their sum is always equal to  $\pi$ .*

One value of this integral is found to be equal to  $\frac{\pi}{2} - \eta$  by introducing  $\eta$  as the variable of integration by means of equa-

tion (12), § 62 *c*. In this way the connection with the EULERIAN relations of § 40 is also set up here. Nevertheless this way of considering the problem to its ultimate conclusion would require a discussion of the different paths of integration. But in any case it is evident that integral (1) represents the complete inverse of the sine function in the sense that it has for values all the solutions of the equation  $\sin J = w$  and only these.

### EXAMPLES

1. The equation

$$\int \frac{dx}{x^2 - a^2} = \frac{1}{2a} \cdot \log \frac{x-a}{x+a}$$

holds when  $a$  is real and  $(x-a)/(x+a)$  is positive. If we could write  $ia$  instead of  $a$  in this equation, the following formula would be obtained:

$$\tan^{-1}\left(\frac{x}{a}\right) = \frac{1}{2i} \cdot \log\left(\frac{x-ia}{x+ia}\right) + \text{const.}$$

The question arises whether, now that the logarithm of a complex number is defined, this equation is not actually true.

Since

$$\log(x \pm ia) = \frac{1}{2} \log(x^2 + a^2) \pm (\theta + 2k\pi)i$$

where  $k$  is an integer and  $\theta$  the numerically least angle such that  $\cos \theta = x/\sqrt{x^2 + a^2}$  and  $\sin \theta = a/\sqrt{x^2 + a^2}$ , we have at once

$$\frac{1}{2i} \log\left(\frac{x-ia}{x+ia}\right) = -(\theta + l\pi),$$

where  $l$  is an integer, and this does differ by a constant from any value of  $\tan^{-1}\left(\frac{x}{a}\right)$ .

2. The standard *formula connecting the logarithmic and inverse circular functions* is

$$\tan^{-1}(x) = \frac{1}{2i} \log \left( \frac{1+ix}{1-ix} \right), \quad x \text{ real.}$$

Verify this formula by putting  $x = \tan y$ , showing that it is “completely” true, the right-hand side reducing to

$$\frac{1}{2i} \log \left( \frac{\cos y + i \sin y}{\cos y - i \sin y} \right) = \frac{1}{2i} \log (\exp 2iy) = y + k\pi,$$

where  $k$  is any integer.

3. Verify the formulas

$$\cos^{-1} x = -i \log (x \pm i\sqrt{1-x^2}), \quad \sin^{-1} x = -i \log (ix \pm \sqrt{1-x^2}),$$

where  $-1 \leq x \leq 1$ , each of which is also “completely” true.

### § 63. The Function $\sqrt[n]{z}$

We shall find no particular difficulty in the study of the  $n$ th root of  $z$  after the investigation of the special case of the square root given in detail in the last paragraphs. We define again:

I. *The  $n$ th root of a complex number  $z$*

$$(1) \quad s = \sqrt[n]{z}$$

( $n$  a positive integer) is a complex number  $s$  which satisfies the equation

$$(2) \quad s^n = z.$$

If we introduce

$$(3) \quad \eta = \log z$$

as the independent variable as in § 58, we find just as we did before that:

II. We obtain all the pairs of corresponding values of  $z$  and  $s$  which satisfy the equation (2), if we put

$$(4) \quad z = e^\eta, \quad s = e^{\eta/n}$$

and consider  $\eta$  as the independent variable.

III. If we take the principal value  $\eta_0$  for  $\log z$  in (3), we obtain the "principal value  $s_0$  of the  $n$ th root" from (4); it is characterized by the fact that its amplitude  $\psi$  satisfies the conditions

$$(5) \quad -\pi/n < \psi \leq \pi/n.$$

All the other values of the logarithm follow from its principal value by the addition of  $2k\pi i$ , where  $k$  is an integer. If  $\alpha$  is the smallest positive remainder of this integer according to the modulus  $n$ , we obtain

$$(6) \quad s = \epsilon^\alpha \cdot s_0$$

by substituting  $\eta = \eta_0 + 2k\pi i$  in (4); in this equation  $\epsilon$  signifies (cf. (3), § 18) the definite complex number:

$$(7) \quad \epsilon = e^{\frac{2\pi i}{n}} = \cos \frac{2\pi}{n} + i \sin \frac{2\pi}{n}.$$

The  $n$  powers of this number

$$(8) \quad \epsilon^0 = 1, \epsilon^1, \epsilon^2, \epsilon^3, \dots, \epsilon^{n-1}$$

are all different from each other; for suppose

$$\epsilon^\alpha = \epsilon^\lambda,$$

it would then follow that  $\epsilon^{\alpha-\lambda} = 1$ ,

which is not true. It follows accordingly that in addition to the principal value there are  $n - 1$  other values of the  $n$ th root; we say:

IV. There are  $n$  and only  $n$  different values of  $s$  which satisfy equation (2) for each value of the complex number  $z$  different from 0 and  $\infty$ .

Therefore to represent the  $n$ th root as a single-valued function of position on a surface, we need only  $n$  sheets of the infinitely many-sheeted surface of the logarithm. To make the function also continuous on the surface, the  $n$ th sheet must be attached to the first one: to do this the final border of the  $n$ th sheet must penetrate all of the parts of the surface lying under it, in order to reach and then be united with the initial border of the first sheet lying lowest.

We can best obtain an idea of this surface by thinking of its gradual formation. This is done as in § 59 for the special case where  $n = 2$ ; we have now only to let the moving radius make

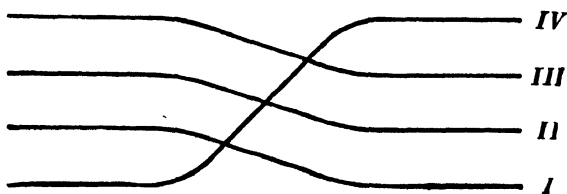

FIG. 36

$n$  circuits instead of 2, and immediately after completing the  $r$ th circuit pierce the parts of the surface lying under this radius and then be combined with the initial border. For  $n = 4$ , Fig. 36 represents a section through the surface perpendicular to the half-axis of negative real numbers, looking at the section from the origin. The origin is a branch-point of the surface of order  $(n - 1)$ ; transforming from the plane to the sphere shows the point  $\infty$  also to be a branch-point of order  $(n - 1)$ .

V. *The connectivity of this surface is the same as that of the sphere even in the general case when  $n$  is arbitrary.* This may be shown by any of the methods spoken of in § 60. If we wish to make a continuous deformation of the surface, we must think of the sheet farthest inside as drawn out of the one next to it, and then think of the sphere thus generated from these two sheets as

drawn out of the sheet third from the inside, etc. Let us make a provisional dissection of the surface with the understanding that it be subsequently combined ;

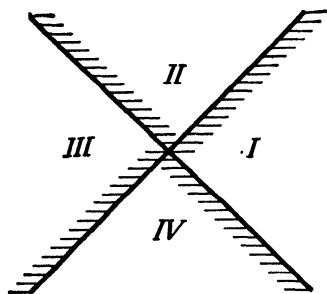

FIG. 37

we now deform each individual sheet according to the process given at the end of § 60 until the angle at the origin is reduced to  $2\pi/n$ , and then place the sheets adjacent to each other. It is scarcely necessary to mention that the sphere arranged in this way can be mapped conformally upon

the  $n$ -sheeted surface by the equation  $s^n = z$ .

The functions which are regular on this surface with the exception of certain poles are rational functions of  $s = \sqrt[n]{z}$  and may be treated as in § 60 *a*.

The discussion of the function

$$\sqrt[n]{\frac{z-a}{z-b}},$$

only apparently more general, may be referred to that of  $\sqrt[n]{z}$ , as was done for  $n = 2$  in § 62. On the other hand the function

$$\sqrt[n]{(z-a)(z-b)}, \quad (n > 2)$$

belongs to another class of irrationalities ; it has a branch-point at infinity in addition to those at  $a$  and  $b$ .

#### § 64. The Equation $s^2 = 1 - z^3$

As an example of a somewhat less simple algebraic relation exhibiting the dependence between  $z$  and  $s$ , we call attention to the equation :

$$(I) \quad s^2 = 1 - z^3.$$

The equation shows that  $s$  is a double-valued function of  $z$ ; the factors:

$$(2) \quad (1 - z^3) = (1 - z)(\epsilon - z)(\epsilon^2 - z), \quad \epsilon = e^{\frac{2\pi i}{3}}$$

show that  $s$  changes its sign when  $z$  makes a circuit about one of the points  $1, \epsilon, \epsilon^2$ , and that therefore these points are branch-points in the  $z$ -plane. In addition to this the point  $z = \infty$  is also a branch-point as is shown by the development:

$$is = z^{3/2} - \frac{1}{2} z^{-3/2} + \dots$$

To separate out a single-valued branch of  $s$ , we connect these four points by cuts in such a way that it is not possible to make a circuit around any one of them without crossing a cut. This can be done symmetrically by drawing three cuts from the three points to infinity in such a way that when prolonged in the opposite direction they pass through the origin. To obtain now a surface on which  $s$  can be represented as a single-valued and continuous function of position, we take two  $z$ -planes, each treated in this way, and fasten them together crosswise along the cuts.

Conversely, 
$$z = \sqrt[3]{(1 - s)(1 + s)}$$

is a triple-valued function of  $s$ . If  $s$  encircles one of the points  $+1$  or  $-1$  of its plane in the positive sense,  $\epsilon$  enters each time as a factor of  $z$ ; these two points are therefore branch-points in the  $s$ -plane. In addition  $s = \infty$  is a branch-point. We must therefore connect one of these three branch-points by cuts with the other two; this is obtained symmetrically when a cut is made in the  $s$ -plane along the real  $s$ -axis with the exception of the part between  $-1$  and  $+1$ . We then take three  $s$ -planes cut in this way and connect them along the cuts. Let us define the sheets in such a way that, for  $s = 0, z = 1$  in the first sheet,  $z = \epsilon$  in the second sheet and  $z = \epsilon^2$  in the third sheet; a positive circuit about each of the two branch-points lying on the

finite part of the surface therefore leads from the first sheet into the second, from this one into the third and from this one again into the first sheet; accordingly we must connect the positive half-plane of the  $\begin{Bmatrix} 1 \\ 2 \\ 3 \end{Bmatrix}$  sheet with the negative half-plane of the  $\begin{Bmatrix} 2 \\ 3 \\ 1 \end{Bmatrix}$  sheet along the cut from  $\infty$  to  $-1$ , but the positive half-plane of the  $\begin{Bmatrix} 1 \\ 2 \\ 3 \end{Bmatrix}$  sheet connects with the negative one of the  $\begin{Bmatrix} 3 \\ 1 \\ 2 \end{Bmatrix}$  sheet along the cut from  $1$  to  $\infty$ . We thus have two branch-cuts from the point at infinity along which the sheets are connected differently; a check on these results is the fact that one circuit about this point in the positive sense (that is, so that the point lies to the left) transfers us from the first to the second sheet as it should be. (The development

$$z = -s^{2/3} + \frac{1}{3}s^{-4/3} + \dots$$

holds in the neighborhood of  $s = \infty$ ; and if we encircle  $s = \infty$  in the positive sense,  $\epsilon^2$  enters as a factor of  $s^{1/3}$  and consequently  $\epsilon$  as a factor of each term of the given development.)

The above two-sheeted surface over the  $z$ -plane and this three-sheeted surface over the  $s$ -plane are mapped by equation (1) reversibly and uniquely and in general conformally upon each other (that is, excepting the branch-points of the two surfaces and their images). To carry out this representation in detail we first determine what lines of each surface correspond to the branch-cuts of the other surface. For this purpose let us put

$$z = x + iy, \quad s = u + iv,$$

and separate equation (1) into its real and imaginary parts; we obtain:

$$\begin{aligned} (3) \quad & u^2 - v^2 = 1 - x^2 + 3xy^2, \\ (4) \quad & 2uv = -3x^2y + y^3. \end{aligned}$$

Hence the line  $u = 0$  (in the three sheets of the surface over the  $s$ -plane) corresponds to the branch-cuts:

$$\left. \begin{aligned} y = 0, & \quad x > 1, \\ y = x\sqrt{3} \\ y = -x\sqrt{3} \end{aligned} \right\}, \quad x < -\frac{1}{2};$$

and the lines

$$\left. \begin{aligned} y = 0, & \quad x < 0, \\ y = x\sqrt{3} \\ y = -x\sqrt{3} \end{aligned} \right\}, \quad x > 0,$$

in the two sheets of the surface over the  $z$ -plane, correspond to the branch-cuts:

$$v = 0, \quad u < -1 \quad \text{and} \quad v = 0, \quad u > 1.$$

Construction of these lines divides each of the two surfaces into six parts; these parts correspond to each other as shown

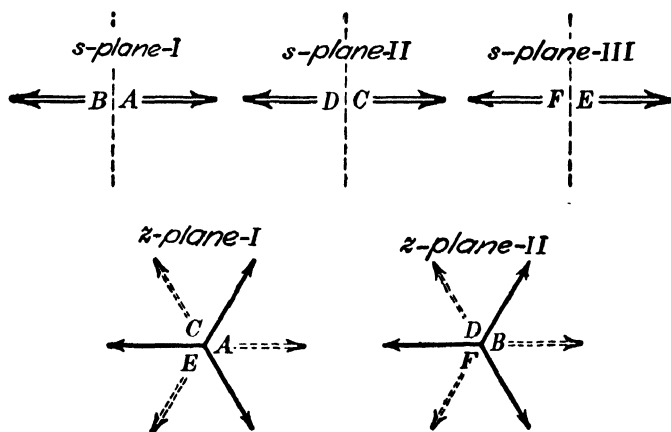

FIG. 38

in Fig. 38. To further determine this correspondence, we must distinguish also between the two sheets of the surface over the  $z$ -plane (as was unnecessary above); this is done by arranging that  $s$  should = 1 at zero of the first sheet, and that

$s$  should be  $-1$  at zero of the second sheet. Thus, for example, the region  $A$  is defined from the fact that it contains the points  $(z=0, s=1)$  and  $(z=1, s=0)$ ; and  $B$  is likewise defined, containing  $(z=0, s=-1)$  and  $(z=1, s=0)$ , etc.

To investigate still further the mapping of the region  $A_s$  upon the region  $A_z$ , we find from a study of the formulas (3) and (4) that the following lines of the two regions correspond:

$$u^2 - v^2 = 1, u > 0, v > 0 \dots x + y\sqrt{3} = 0, y < 0$$

$$u^2 - v^2 = 1, u > 0, v < 0 \dots x - y\sqrt{3} = 0, y > 0$$

$$v = 0, \quad 0 < u < 1 \dots y = 0, \quad 0 < x < 1.$$

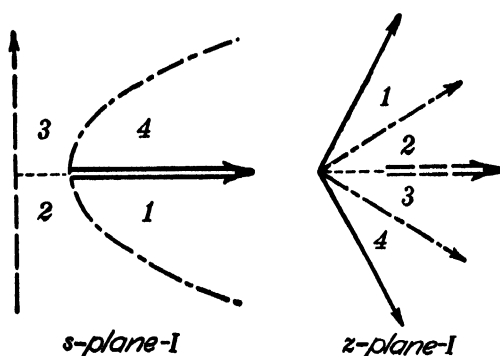

FIG. 39

We thus obtain just four subregions which correspond to each other as shown in Fig. 39.

A study of the curves which correspond to the parallels to the axes in each of the planes would be

of no aid in obtaining further details here. On the contrary we find from equations (3) and (4) that the hyperbolas of the  $s$ -plane:

$$u^2 - v^2 = C_1, \quad 2uv = C_2,$$

correspond to curves of the  $z$ -plane whose properties are obtained from their equations in polar coordinates:

$$\rho^3 \cos 3\phi = 1 - C_1, \quad \rho^3 \sin 3\phi = -C_2.$$

**EXAMPLES**

1. Show, for  $w = z^2 - 1$ , that as  $w$  describes the circle  $|w| = k$ , the two corresponding positions of  $z$  each describe the Cassinian oval  $\rho_1 \cdot \rho_2 = k$  ( $\rho_1, \rho_2$  being the distances from the points  $\pm 1$ ). Trace the ovals for different values of  $k$ .

2. If  $w = 2z + z^2$ , show that the circle  $|z| = 1$  corresponds to a cardioid in the plane of  $w$ .

3. If  $(w + 1)^2 = 4/z$ , the unit circle in the  $w$ -plane corresponds to a parabola  $r \cos^2 \frac{\theta}{2} = 1$  in the  $z$ -plane, and the inside of the circle to the outside of the parabola.

4. Show, for the transformation  $w = \{(z - ia)/(z + ia)\}^2$ , that the upper half of the  $w$ -plane may be made to correspond to the interior of a certain semi-circle in the  $z$ -plane.

5. If  $w = az^m + bz^n$ , where  $m, n$  are positive integers and  $a, b$  real, show that as  $z$  describes the unit circle,  $w$  describes a hypocycloid or an epicycloid.

6. Discuss the mapping of parallels to the  $z$ -axes by means of  $\cot z$ .

7. Show that a cut along a complete hyperbola separates branches of  $\sin^{-1} w$ .

8. If  $w = \cos z$ ,  $z = w + \frac{1}{\eta}$  where  $\eta = e^{i\alpha}$ . Hence when  $z$  moves horizontally or vertically determine the map on the  $\eta$ -plane and then on the  $w$ -plane.

**§ 65. Transition from MITTAG-LEFFLER'S Division into Partial Fractions to WEIERSTRASS'S Development in a Product**

Suppose we have a given function of the kind considered in § 51, all of whose poles are simple and all of whose residues

= 1, and which consequently may be represented by a series of the form :

$$(1) \quad \phi(z) = \sum_{\nu=0}^{\infty} \left\{ \frac{1}{z - a_{\nu}} + a_{\nu_0} + a_{\nu} z + \cdots a_{\nu k} z^k \right\},$$

we can then show (as the converse of Theorem II, § 46) that this function is the logarithmic derivative of a transcendental integral function  $f(z)$ ; that is, that

$$(2) \quad \phi(z) = \frac{d \log f(z)}{dz} = \frac{f'(z)}{f(z)}.$$

According to VI, § 35,  $\int_0^z \phi(z) dz$  is regular in every simply connected domain which contains none of the points  $a_{\nu}$  in its interior; if  $z$  encircles one of the points  $a_{\nu}$ , this integral is increased by  $2\pi i$ . Consequently if  $b$  is not one of the points  $a_{\nu}$ ,

$$\exp \left( \int_b^z \phi(z) dz \right)$$

is a regular function over the whole plane apart from the points  $a_{\nu}$ ; in the neighborhood of  $a_{\nu}$  it is equal to the product of  $z - a_{\nu}$  by a regular function. It can therefore be made a regular function in the whole plane, that is, a transcendental integral function, by assigning to it the value zero at the points  $a_{\nu}$ . Thus  $\phi(z)$  is the logarithmic derivative of this transcendental integral function.

On account of its uniform convergence, the series (1) may be integrated term by term along an arbitrary path which does not contain any of the points  $a_{\nu}$ . Without loss of generality\* we may suppose that zero is not one of the  $a_{\nu}$ ; we can then use zero as the lower limit of the integral and so obtain the following series which is absolutely and, in the same domain as (1),

\* If zero belongs to the  $a_{\nu}$ , we need only to investigate  $\phi(z) - 1/z$  instead of  $\phi(z)$ .

uniformly convergent :

$$(3) \quad \int_0^1 \phi(z) dz = \sum_{\nu=1}^{\infty} \left\{ \log \left( 1 - \frac{z}{a_{\nu}} \right) + a_{\nu_0} z + \dots + \frac{a_{\nu k}}{k+1} z^{k+1} \right\}.$$

Since the exponential function is a continuous function of its argument (A. A. 7, § 50) the lemma that

$$(4) \quad \exp \left( \lim_{n \neq \infty} s_n \right) = \lim_{n \neq \infty} \left( \exp s_n \right)$$

is true (provided  $\lim_{n \neq \infty} s_n$  exists); from it and from the definition of the infinite series and of the infinite product, it follows that

$$(5) \quad \exp \left( \sum_{\nu=1}^{\infty} u_{\nu} \right) = \prod_{\nu=1}^{\infty} e^{u_{\nu}},$$

that is :

I. *When the series  $\sum_{\nu=1}^{\infty} u_{\nu}$  converges, the product  $\prod_{\nu=1}^{\infty} e^{u_{\nu}}$  also converges, and in fact to a value different from zero in the limit.*

Consequently we can deduce from equation (3) the following :

$$(6) \quad f(z) = e^{\int_0^z \phi(z) dz} = \prod_{\nu=1}^{\infty} \left\{ \left( 1 - \frac{z}{a_{\nu}} \right) e^{a_{\nu_0} z + \dots + \frac{a_{\nu k}}{k+1} z^{k+1}} \right\}.$$

II. *The transcendental integral function  $f(z)$  for which the points  $a_{\nu}$  are simple zeros may be represented analytically in the form of the infinite product (6), provided that the points  $a_{\nu}$  satisfy the conditions of § 51 and that the coefficients  $a_{\nu\rho}$  are determined according to the rules given there.*

If now we have given any transcendental integral function  $F(z)$  for which also the points  $a_{\nu}$  are simple zeros, the quotient  $F(z)/f(z)$  will be a function regular over the whole plane, and consequently a transcendental integral function  $E(z)$  which in addition is nowhere zero. The logarithm of such a function is

also regular over the whole plane (cf. X, § 38); consequently, we have

$$(7) \quad E(z) = e^{g(z)}$$

in which  $g(z)$  is also a transcendental integral function. Hence the theorem:

III. *The most general transcendental integral function for which the points  $a_\nu$  are simple zeros is represented in the form*

$$(8) \quad F(z) = f(z)e^{g(z)}$$

in which  $f(z)$  is the product (6), and  $g(z)$  is any transcendental integral function.

As an illustration of Theorem II we cite the following two *product forms of the sine* which are obtained from the developments of the cotangent in partial fractions, (2) and (18), § 52:

$$(9) \quad \sin \pi z = \pi z \cdot \prod' \left\{ \left( 1 - \frac{z}{\nu} \right) \cdot e^{z/\nu} \right\}$$

and

$$(10) \quad \sin \pi(a+z) = \sin(\pi a) \cdot e^{\pi z \cot(\pi a)} \prod_{\nu=-\infty}^{+\infty} \left\{ \left( 1 - \frac{z}{\nu-a} \right) \cdot e^{z/(\nu-a)} \right\};$$

in particular for  $a = 1/2$ :

$$(11) \quad \cos \pi z = \prod_{\nu=-\infty}^{+\infty} \left\{ \left( 1 - \frac{2z}{2\nu-1} \right) \cdot e^{2z/(2\nu-1)} \right\}.$$

The accent on the product sign in (9) has a meaning analogous to that given earlier to the accent on the summation sign.

If in the products (9) and (11) we take together in pairs those factors which belong to oppositely equal values of  $\nu$  and  $2\nu-1$  respectively, we obtain the elementary product-forms for these functions (A. A. § 83)\*.

\* That is,  $\sin z = m \prod_{k=1}^{\infty} \left( 1 - \frac{z^2}{k^2 \pi^2} \right)$ ,  $\cos z = \prod_{k=1}^{\infty} \left( 1 - \frac{4z^2}{(2k-1)^2 \pi^2} \right)$ . — S. E. R.

## EXAMPLE

Write down an infinite product which defines a transcendental integral function of  $z$  having simple roots in the points

$$z = n + i/n, \quad n = 1, 2, \dots,$$

but not vanishing elsewhere. Prove that the product has the desired property.

## MISCELLANEOUS EXAMPLES

1. Show that if  $\theta$  is real and  $\sin \theta \sin \phi = 1$ , then

$$\phi = (k + 1/2)\pi + i \cdot \log \cot \frac{1}{2}(k\pi + \theta)$$

where  $k$  is any even or any odd integer, according as  $\sin \theta$  is positive or negative. Cf. examples following § 40 and § 62 *d*.

2. If  $a \cos \theta + b \sin \theta + c = 0$ , where  $a, b, c$  are real and  $c^2 > a^2 + b^2$ , then

$$\theta = m\pi + \alpha \pm i \log \left\{ \frac{|c| + \sqrt{c^2 - a^2 - b^2}}{\sqrt{a^2 + b^2}} \right\}$$

where  $m$  is any odd or any even integer, according as  $c$  is positive or negative, and  $\alpha$  is the least angle whose cosine and sine are  $a/\sqrt{a^2 + b^2}$  and  $b/\sqrt{a^2 + b^2}$ .

3. Show that if  $x$  is real, then

$$\begin{aligned} \frac{d}{dx} \exp \{(a + ib)x\} &= (a + ib) e^{(a+ib)x}, \quad \int \exp \{(a + ib)x\} dx \\ &= \frac{\exp (a + ib)x}{(a + ib)}. \end{aligned}$$

4. Prove that, for  $a > 0$ ,  $\int_0^\infty \exp \{-(a + ib)x\} dx = \frac{1}{a + ib}$ .

5. Determine the number and the approximate positions of the roots of the equation  $\tan z = az$ , where  $a$  is real.

It is easily shown that this equation has infinitely many real roots. Next let  $z = x + iy$  and equate real and imaginary parts.

Thus

$$(\sin 2x)/(\cos 2x + \cosh 2y) = ax,$$

$$(\sinh 2y)/(\cos 2x + \cosh 2y) = ay,$$

and therefore, if  $x$  and  $y$  are not zero, we have

$$(\sin 2x)/2x = (\sinh 2y)/2y.$$

But this is impossible, since the left-hand side is numerically less, and the right-hand side numerically greater, than unity. It follows that  $x = 0$  or  $y = 0$ . But if  $y = 0$ , we come back to the real roots of the equation. If  $x = 0$ ,  $\tanh y = ay$ . It may be shown graphically that this equation has no real root other than zero if  $a \leq 0$  or  $a \geq 1$ , and two such roots if  $0 < a < 1$ . Thus there are two purely imaginary roots if  $0 < a < 1$ ; otherwise all the roots are real.

6. The equation  $\tan z = az + b$ ,  $a$  and  $b$  real and  $b \neq 0$ , has no complex roots if  $a \leq 0$ . If  $a > 0$  the real parts of all the complex roots are numerically greater than  $|b/2a|$ . Prove.

7. The equation  $\tan z = a/z$ ,  $a$  real, has no complex roots but has one purely imaginary root if  $a < 0$ . Prove.

8. Discuss the transformation  $z = c \cdot \cosh(\pi w/a)$ , showing in particular that the whole  $z$ -plane corresponds to any one of an infinite number of strips in the  $w$ -plane each parallel to the  $u$ -axis and of breadth  $2a$ . Show also that to the line  $u = u_0$  corresponds the ellipse

$$\left\{ \frac{x}{c \cosh\left(\frac{\pi u_0}{a}\right)} \right\}^2 + \left\{ \frac{y}{c \sin\left(\frac{\pi u_0}{a}\right)} \right\}^2 = 1,$$

and that for different values of  $u_0$  these ellipses form a confocal system; and that the lines  $v = v_0$  correspond to the associated

system of confocal hyperbolas. Trace the variation of  $z$  as  $w$  describes the whole of a line  $u = u_0$  or  $v = v_0$ . How does  $w$  vary as  $z$  describes the degenerate ellipse and hyperbola formed by the segment between the foci of the confocal system and the remaining segments of the axis of  $x$ ?

9. Verify that the transformation  $z = c \cosh (\pi w/a)$  can be compounded from the transformations

$$z = cz_1, \quad z_1 = \frac{1}{2}(z_2 + 1/z_2), \quad z_2 = c \exp(\pi w/a).$$

10. Discuss similarly the transformation  $z = c \tanh (\pi w/a)$ , showing that to the lines  $u = u_0$  correspond the coaxial circles

$$\{x - c \coth (\pi u_0/a)\}^2 + y^2 = c^2 \operatorname{cosech}^2 (\pi u_0/a),$$

and to the lines  $v = v_0$  correspond the orthogonal system of coaxial circles.

11. Discuss the transformation

$$z = \log \left\{ \frac{\sqrt{w-a} + \sqrt{w-b}}{\sqrt{b-a}} \right\}.$$

showing that the straight lines for which  $x$  and  $y$  are constant correspond to sets of confocal ellipses and hyperbolas whose foci are the points  $w = a$  and  $w = b$ .

$$\begin{aligned} \text{Here } \sqrt{w-a} + \sqrt{w-b} &= \sqrt{b-a} \exp(x+iy) \\ \sqrt{w-a} - \sqrt{w-b} &= \sqrt{b-a} \exp(-x-iy), \end{aligned}$$

and it is readily found that

$$\begin{aligned} |w-a| + |w-b| &= |b-a| \cdot \cosh 2x, \\ |w-a| - |w-b| &= |b-a| \cdot \cos 2y. \end{aligned}$$

12. Prove that if neither  $a$  nor  $b$  is real then

$$\int_0^\infty \frac{dx}{(x-a)(x-b)} = \frac{\operatorname{Log} a - \operatorname{Log} b}{a-b}.$$

each logarithm having its principal value. Verify the result if  $a = ci$ ,  $b = -ci$  where  $c$  is positive. Discuss the cases where  $a$  or  $b$  or both are real and negative.

13. Show that if  $a$  and  $\beta$  are real, and  $\beta > 0$ ,

$$\int_0^{\infty} \frac{dx}{x^2 - (\alpha + i\beta)^2} = \frac{\pi i}{2(\alpha + i\beta)}.$$

What is the value of the integral when  $\beta < 0$ ?

14. If an algebraic plane curve has a double point with distinct tangents neither of which is vertical, what can be said of the corresponding RIEMANN'S surface?

15. Of a certain function  $f(z)$  I know that it is single-valued and regular in the region of the  $z$ -plane lying between the ellipses

$$\frac{x^2}{4} + \frac{y^2}{9} = 1, \quad \frac{x^2}{25} + \frac{y^2}{36} = 1,$$

and that along the arc of the circle of radius 4, with its center at the point  $z = 0$ , which lies in the first quadrant  $f(z)$  has the value  $3 \cdot 5 - 8 \cdot 3 i$ . What can you say about  $f(z)$ ?

16. Find all the values of  $\tan^{-1}(1 + i)$  to three figures.

17. The function of the real variable  $x$  defined by

$$\pi f(x) = p\pi + (q - p) I(\log x)$$

(where  $I(u)$  denotes the imaginary part of  $u$ ) is equal to  $p$  when  $x$  is positive, and equal to  $q$  when  $x$  is negative.

18. The function of  $x$  defined by

$$\pi f(x) = p\pi + (q - p) I\{\log(x - 1)\} + (r - q) I(\log x)$$

is equal to  $p$  for  $x > 1$ , to  $q$  for  $0 < x < 1$ , to  $r$  for  $x < 0$ .

19. Draw the graph of the function  $I(\log x)$  of the real variable  $x$ . (The graph consists of the positive halves of the lines  $y = 2k\pi$  and the negative halves of the lines  $y = (2k + 1)\pi$ .)

20. Show that  $\exp (1+i)z = \sum_0^{\infty} 2^{\frac{1}{2}n} \cdot \exp \left( \frac{1}{4} n\pi i \right) \cdot \frac{z^n}{n!}$ .

21. Expand  $\cos z \cosh z$  in powers of  $z$ .

We have  $\cos z \cosh z - i \sin z \sinh z = \cos (1+i)z$

$$\begin{aligned} &= \frac{1}{2} [\exp (1+i)z + \exp \{-(1+i)z\}] \\ &= \frac{1}{2} \sum_0^{\infty} 2^{\frac{1}{2}n} \{1 + (-1)^n\} \cdot \exp \left( \frac{1}{4} n\pi i \right) \cdot \frac{z^n}{n!}. \end{aligned}$$

Similarly  $\cos z \cosh z + i \sin z \sinh z = \cos (1-i)z$

$$= \frac{1}{2} \sum_0^{\infty} 2^{\frac{1}{2}n} \{1 + (-1)^n\} \cdot \exp \left( -\frac{1}{4} n\pi i \right) \cdot \frac{z^n}{n!}.$$

$$\begin{aligned} \text{Hence } \cos z \cosh z &= \frac{1}{2} \sum_0^{\infty} 2^{\frac{1}{2}n} \{1 + (-1)^n\} \cdot \cos \frac{1}{4} n\pi \cdot \frac{z^n}{n!} \\ &= 1 - \frac{2^2 z^4}{4!} + \frac{2^4 z^8}{8!} - \dots \end{aligned}$$

22. Expand  $\sin z \sinh z$ ,  $\sin z \cosh z$ ,  $\cos z \sinh z$  each in powers of  $z$ .

## CHAPTER VI

### GENERAL THEORY OF FUNCTIONS

#### § 66. The Principle of Analytic Continuation

WE have already investigated a series of many-valued functions of a complex variable in the previous chapter; the question of prime importance in this connection is the following: When several values of one complex variable are associated with each value of another, under what conditions are these first values, taken together, to be regarded as a many-valued function of the latter (and not as different single-valued functions)? In the investigation of this question we begin with the following considerations:

Let a bounded domain  $S$  and a function of  $z$ , regular in this domain, be given in the plane (or on the sphere). We consider then a domain  $S'$  of which  $S$  is a part, and inquire whether a function exists which is regular and, by definition, single-valued everywhere inside of  $S'$  and which is identical with the first named function inside of  $S$ . (That only one such function can exist in any case, when one exists at all, follows from theorem VII, § 39.)

I. *If such a function is found then we say, according to WEIERSTRASS: we have continued the given function analytically beyond the given domain for which it is defined.*

The question concerning the existence of such a function may be regarded as belonging to the subject of linear partial differential equations. The real and the imaginary parts of a regular

function of a complex argument satisfy, as we know, the CAUCHY-RIEMANN differential equations; another formulation of the problem is therefore the following: Given the values of two functions  $\bar{u}$ ,  $\bar{v}$  along a line  $L$  (a piece of the boundary of the original domains); we desire to find two functions  $u$ ,  $v$  which satisfy the differential equations:

$$\frac{\partial u}{\partial x} = \frac{\partial v}{\partial y}, \quad \frac{\partial v}{\partial x} = -\frac{\partial u}{\partial y}$$

in the neighborhood of this curve and which reduce to  $\bar{u}$ ,  $\bar{v}$  respectively along this curve. But this formulation of the problem leads into difficulties when we attempt to state precisely what continuity properties are presupposed for the curve  $L$  and the assigned values along  $L$ , and what properties of this kind we may require of the functions to be determined. On this account the problem is not discussed here from this standpoint, but we use, as did WEIERSTRASS, the development of the regular functions in power series.

Let a regular function  $f(z)$  be defined in a domain  $S$ , and let  $a$  be an inner point of this domain. The TAYLOR'S series

$$(1) \quad f(a) + (z-a)f'(a) + \frac{(z-a)^2}{2!}f''(a) + \dots + \frac{(z-a)^n}{n!}f^n(a) + \dots,$$

then converges (III, § 37) at any rate inside of the largest circle  $\Gamma$  with center  $a$  which belongs entirely to the domain  $S$ , and in fact converges to  $f(z)$ . *But it is altogether possible that it converges outside of  $\Gamma$  and inside of a circle  $\Gamma'$  concentric with  $\Gamma$ .* The surface of this circle  $\Gamma'$  has at least one continuous domain  $\Sigma$  in common with the given domain  $S$  of which the surface of  $\Gamma$  is a part; it is also possible (cf. Fig. 40) that it has in common with  $S$  another or several other domains  $\Sigma'$  which are not connected with  $\Sigma$ ; for these however the following theorems do not hold. But inside of  $\Sigma$  the value of series (1) is, according

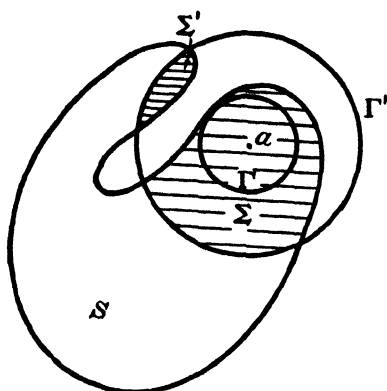

FIG. 40

to V, § 38, a single-valued, regular function of  $z$  which may be designated provisionally by  $\phi(z)$ . The difference

$$\phi(z) - f(z)$$

is therefore regular everywhere inside of  $\Sigma$  and is everywhere  $= 0$  in a part of  $\Sigma$ , viz. inside of  $\Gamma$ . Hence it is zero in the whole domain  $\Sigma$  according to VII, § 39; that is, we have the theorem :

II. *When series (1) converges also at points which do not belong to the original domain for which the function  $f(z)$  is defined, then the two functions coincide in the whole continuous domain  $\Sigma$ , which is common to the domains defining the function and the series and which contains the point  $a$ .*

Definition :

III. *Series (1) represents an "analytic continuation" of the given "element of the function"  $f(z)$  in all parts of its domain of convergence  $S_1$  not belonging to  $\Sigma$ ; the domain for which this function was defined, originally limited to  $S$ , is in this way enlarged.*

IV. *All the elements obtained from a given element of the function by repeated analytic continuation together constitute an analytic function.\**

The many-valued functions investigated in the previous chapter satisfy this definition as is easily shown. We can go

\* The analytic function is thus defined by a power series, whose radius of convergence is not zero, together with all possible continuations of that series. Cf. HARKNESS AND MORLEY, *Introduction*, etc., pp. 154, 314; OSGOOD, *Lehrbuch*, Vol. 1, pp. 89, 189. — S. E. R.

from one branch of the function to any other branch by analytic continuation; but such continuation cannot lead to values other than those that are each time under consideration. This latter statement follows from the following general theorem:

*V. If a function  $f(z)$  is by definition regular in a domain  $S$  and if it satisfies an equation:*

$$G(z, f(z), f'(z)) = 0$$

*at all points of this domain, where  $G$  is understood to be a rational integral function, then the same equation holds for all analytic continuations of  $f(z)$ .*

To prove this theorem we develop  $G$  in powers of  $z - a$ ; since this development is by hypothesis zero everywhere inside of  $\Sigma$ ,  $G$  must be zero everywhere inside of  $S_1$  according to VII, § 39.

The analytic continuation of the integral of a single-valued function is particularly simple; such an integral is defined at present as a single-valued function of its upper limit, in a simply connected domain which contains the lower limit but no singular point of the function to be integrated; that is, while the path of integration remains entirely in this domain (VI, § 35). If the path of integration then reaches beyond this domain, we obtain an analytic continuation of the element of the function first defined: and different continuations of this kind lead to different values of the function when the path of integration considered encloses a singular point at which the residue is not zero. Examples of this are found in §§ 56, 57 *a*, 62 *d*.

### § 67. General Construction of the RIEMANN'S Surface determined by an Analytic Function

As in the previous paragraph, let an element of the function  $f(z)$  be given in a domain  $S_1$ ; suppose we have found a con-

tinuation  $f_1(z)$  of  $f(z)$  in a domain  $S_2$  which has a continuous domain  $\Sigma_1$  in common with  $S_1$ ; then suppose a second continuation  $f_2(z)$  in a domain  $S_3$  which has a continuous domain  $\Sigma_2$  in common with  $(S_1 + S_2 - \Sigma_1)$ ; then a third continuation, etc.; finally an  $n$ th continuation in a domain  $S_{n+1}$  which has a continuous domain  $\Sigma_n$  in common with

$$(S_1 + S_2 - \Sigma_1 + S_3 - \Sigma_2 + \dots + S_n - \Sigma_{n-1}).$$

It is now possible that  $S_{n+1}$  has in common with  $S_1$  a domain  $\Sigma_{n+1}$  which is not connected with  $\Sigma_1$ . (Fig. 40 shows this possibility for  $n=1$ , Fig. 41 shows it for  $n=5$ .) In this domain,

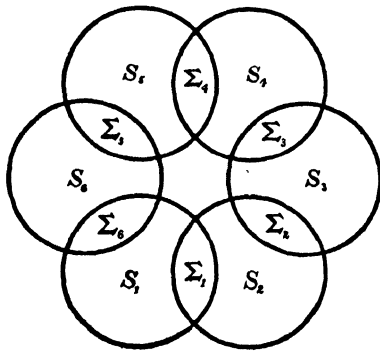

FIG. 41

therefore, two elements of the function are defined, viz.  $f$  and  $f_n$ ; but we have yet no basis for the statement that these elements must always be the same. We have accordingly two cases to dispose of.

I. *When all the continuations which are obtainable directly or indirectly from a given element of the function, always furnish the same values of the function for the same values of the argument, we say: the element of the function first given generates a single-valued analytic function.*

But when that is not the case, the existing relations are made clear by the following geometrical representation. We think of the defining domain of the function as increasing step by step by adding in turn to the original domain  $S_1$ , first  $S_2 - \Sigma_1$ , then  $S_3 - \Sigma_2$ , etc. When finally  $S_{n+1} - \Sigma_n$  has a part  $\Sigma_{n+1}$  extending over a part of the original domain, as in Figs. 40 and 41, and when  $f_n$  coincides with  $f$  in this part, then we add, not the whole

of  $S_{n+1} - \Sigma_n$  but only  $S_{n+1} - \Sigma_n - \Sigma_{n+1}$ ; removing the bounding curve between the newly added piece and  $\Sigma_{n+1}$ , we have a doubly connected domain (eventually multiply connected). *This domain is momentarily the defining domain of the function; it is by definition single-valued in this domain.* But when

$f_n$  does not coincide with  $f$  in  $\Sigma_{n+1}$ , then we add on all of  $S_{n+1} - \Sigma_n$  to the existing domain which may be regarded as a material, flat sheet. This added piece will then extend over  $S_1$  in such a way that the part of the plane designated by  $\Sigma_{n+1}$  is doubly covered by our domain, that

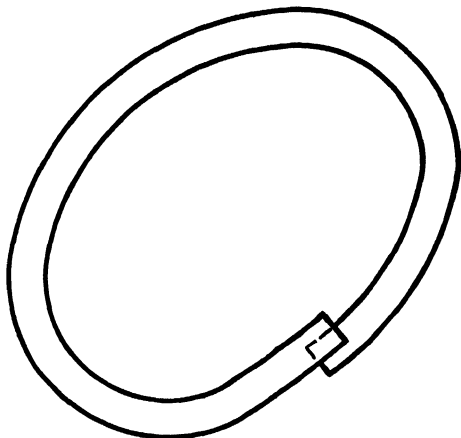

FIG. 42

is, is covered by two "sheets." We think of these sheets as completely separated from each other — perhaps by supposing space between them. *The domain momentarily defining the function has therefore in the simplest case the form of a flat strip bounded by curved lines, the ends of the strips extending partly one over the other (Fig. 42).*

Of course one case then the other can appear according to the direction in which we proceed with the continuation. But by proceeding with each new continuation in the prescribed manner for the case at hand, we obtain finally the entire RIEMANN'S surface which belongs to the function generated by the given element of the function. We say :

II. *The totality of analytic continuations of an element of a function forms in general a many-valued function of  $z$ , which however*

*can be regarded as a single-valued function of position on a suitably constructed RIEMANN'S surface.*

To be sure it is possible that after a series of continuations which have led to different values of the function for the same  $z$  — for example after a series of circuits of the band shown in Fig. 42 — we may come again to values, or more exactly to developments, which were already obtained there. In this case we will have to fuse the newly generated sheet of the RIEMANN'S surface with one already formed. We encounter difficulties here in the geometrical representation when the two sheets under consideration do not lie directly over each other; we must then imagine that one of these two sheets pierces the intermediate ones at bridges (cuts) in order to be combined with the other. But the bridges arising in this way are not essential for the surface; they may be shifted in the most varied way, and we are to keep in mind in this connection that two parts of the surface crossing in a cut are not to be looked upon as having a continuous connection with each other. We were acquainted with all these details in treating the individual functions in the previous chapter so that further study is unnecessary here. Only one possibility, of which we have had as yet no example, remains to be mentioned: Bridges (cuts) may also intersect in the most varied manner. Of course we seek to avoid this possibility when it occurs, but it is not always possible to do so.

We may also think of the RIEMANN'S surface as spread out over the sphere instead of over the plane. For this purpose we map the neighborhood of the point at infinity upon the neighborhood of the origin of the  $z'$ -plane by the substitution:

$$z' = 1/z$$

by which the given function  $f(z)$  transforms into a function  $\phi(z')$ ; we then study this function  $\phi(z')$  in the  $z'$ -plane. If the origin

of the  $z'$ -plane can be reached by an analytic continuation of the function  $\phi(z')$  in this plane, we regard the point  $\infty$  of the  $z$ -sphere as belonging to the domain defining the function  $f(z)$  upon that sphere.

**§ 68. Singular Points and Natural Boundaries of Single-valued Functions**

When the analytic continuations of an element of a function cover the whole sphere uniquely, this element of the function generates a function which is single-valued over the whole sphere. But such a function is necessarily a constant according to IV, § 44. Hence :

I. *The domain for which a single-valued function not a constant is defined, never covers the entire sphere.*

A series of further possibilities thus arise for discussion.

The case is at once conceivable that there are one or more points which lie upon the boundary of the domains of convergence of certain continuations, but which do not lie in the interior of any one of these domains. Let us consider the extreme case where we have only one such point. This point itself can therefore not be reached by the continuations of the function but any other point of its neighborhood can be so reached. Thus the definition :

II. *A point such that it cannot be reached by any continuation of the function, but that any other point of its neighborhood can be so reached, is called an isolated singular point of the function.*

The behavior of a function in the neighborhood of such a point has already been investigated in §§ 43, 47, 48; the following is a recapitulation of that investigation :

III. *An isolated singular point of a single-valued function is either a pole or an essential singularity, — a pole being a point at*

*which the function has an infinity of an assignable integral order and an essential singularity, a point in whose neighborhood the function approaches arbitrarily near to any arbitrary value an infinite number of times.\**

It is further conceivable that the function has an infinite number of poles. The totality of these poles considered as an infinite set of points must necessarily have, therefore, at least one limit point according to XVI, § 25. In such a case the limit point itself cannot belong to the domain for which the function is regular; for then the function would have to be regular also in a neighborhood of this point. Moreover, it cannot be a pole; for, according to IV, § 43 a circle of so small a radius can be drawn about a pole such that no other singular point of the function lies in it. Consequently, we say:

IV. *We designate as an isolated essential singular point of the function such a point in whose neighborhood, arbitrarily small, infinitely many poles, but no other singularity of the function lie, provided that this point is isolated not from poles, but from other essential singular points of the function; and it is classed with the essential singular points of Theorem III as the "first kind" of such points.*

It may be mentioned without proving that for these singular points also, the theorem holds that the function comes infinitely often arbitrarily near to any arbitrary value in a neighborhood as small as we please about one of these points.

V. *Further, infinitely many essential singular points of the first kind may "accumulate" about such a point of the "second kind," infinitely many such points of the "second kind" about such a point of the "third kind," etc.*

These possibilities will not be discussed further.

\* Cf. Exs. 1-6 at the end of § 68. — S. E. R.

However, a few words must be given to another possibility, viz. where all the points of a line are such that they never lie in the inside of the domain of convergence of the continuation of a given element of the function; and we are to understand the word line here in the most general sense defined in IX, § 25. Such a line is called, therefore, a line of singularities of the function. Its points may lie in part (to be sure not inside, but) upon the boundary of the domain of convergence of the analytic continuation of the original, given element of the function; but the case can also arise where such a point does not lie upon the boundary of such a domain of convergence. By many authors only the points of the first kind, not the points of the second kind, are designated as singular points of the function.

The case where such a line of singularities is closed is of particular interest. It delimits then a region of the surface beyond which the function cannot be continued; it is not possible on the basis of our previous agreements, to enlarge the domain for which the function is defined beyond this region of the surface; and it appears, moreover, that such enlargement of the domain cannot be obtained by changing or supplementing these stipulations. On the contrary, we define:

VI. *A closed line of singularities of a function is a natural boundary for the function.*

Such functions with natural boundaries do not appear in the elementary parts of the theory of functions, but examples of such functions are found in the theory of elliptic functions.

Moreover, these natural boundaries of analytic functions are always to be distinguished from the artificial cuts which we have used at times to separate the totality of values of a many-valued function into distinct branches for the purpose of better studying them; beyond such a cut the analytic continuation takes place in another branch.

## EXAMPLES

1. The essential singularity may be contrasted as follows: If the reciprocal of the function has a point for an ordinary point, *this point is a pole*, that is, it is, to be sure, *a zero for the reciprocal* of the function; but when the value of the reciprocal of the function is not determinate at the point, then the point is an *essential singularity for the function as well as the reciprocal*.

2. Consider the function  $e^{1/z}$ . Show that as  $z$  approaches zero, this function, elsewhere one-valued, may be made to approach any arbitrary value, that is,  $z = 0$  is an "essential singularity."

$$\text{HINT: } e^z = 1 + z + \frac{z^2}{2!} + \dots$$

$$e^{1/z} = 1 + \frac{1}{z} + \frac{1}{(z')^2 \cdot 2!} + \dots$$

Therefore,  $z' = 0$  or  $z = \infty$  is an essential singular point, that is, there is no number  $m$  such that  $z^m$  times a power series in  $z$  is holomorphic, that is,  $z' = 0$  gives an infinite number of infinities. Thus  $z' = 0$ ,  $z = \infty$  is an essential singularity.

3. Show by using Ex. 2 that in the vicinity of an essential singular point an infinite number of poles exist.

4. Discuss  $e^{\frac{1}{z-a}}$  for its poles and essential singular point.

5. Discuss  $\sin z$ ,  $1/\sin z$ ,  $1/\sin(1/z)$  as in Ex. 4.

6. Rational functions have a finite number of poles; transcendental functions are everywhere holomorphic except they have at least one essential singular point. Rational integral functions and transcendental integral functions are holomorphic everywhere in the finite part of the plane, but one has poles at infinity while the other has an essential singularity at infinity. Give illustrations.

7. If  $f_1(z)$  and  $f_2(z)$  are any two one-valued analytic functions of  $z$  with a finite number of singular points, then the expression

$$\frac{f_1(z) + f_2(z)}{2} + \frac{f_1(z) - f_2(z)}{2} \cdot \phi(z)$$

defines, inside and out of the unit circle about the origin, parts of two distinct analytic functions,  $f_1(z)$ ,  $f_2(z)$ . Show that the circle itself is not a natural boundary for either of these functions.

### § 69. Singular Points and Natural Boundaries of Many-valued Functions

If we are studying a many-valued function, then considerations analogous to those carried out in the previous paragraph for the plane are to be made for the RIEMANN'S surface upon which the many-valued functions to be investigated is a single-valued function of position. We must then speak of singular points and lines in a distinct sheet; it is not at all necessary that such points and lines which appear in the different sheets be situated vertically over each other. In particular it is not necessary that all parts of the  $z$ -plane be covered by the same number of sheets of the surface.

But many-valued functions have other singular points of a different kind, viz., the *branch-points*. We have already had a number of examples of such singularities in the previous chapter; according to present considerations we obtain them in general as follows: Let a point  $a$  be given and a circle about it as center with a sufficiently small radius; let  $b$  be a point inside of this circle and different from  $a$ . Let an element of the function be given about  $b$ ; we limit the discussion to such continuations of this element which can be obtained without going outside of this circle. It is then possible that *none of these con-*

tinuations reach the point  $a$ , that they reach every other point inside of the circle, but that continuation along a smaller circle concentric to the first only leads to the original element after  $n$  circuits ( $n > 1$ ). In this case  $n$  sheets of our RIEMANN'S surface are connected at  $a$  exactly as is exhibited in § 63 in the investigation of the function

$$(1) \quad w = \sqrt[n]{z - a}$$

(studied for  $a = 0$ ). If we map the parts of the  $n$  sheets lying inside of the first named circle upon the  $w$ -plane by means of this function, then the images of these sheets are arranged smoothly and contiguously in this plane and cover the neighborhood of the origin uniquely. The function  $f(z)$  to be investigated is thus transformed into a function of  $w$ ,  $\phi(w)$ , whose particular branch under consideration is regular at each point of the neighborhood of the origin, excepting the origin itself, and which returns into itself after one circuit about the origin.

If we can now show that the value of  $f(z)$  remains less than an assignable limit however near  $z$  may approach  $a$  in any direction, then  $\phi(w)$  also remains less than this limit when  $w$  approaches the origin arbitrarily. But then the origin cannot be a singular point of  $\phi(w)$  according to I, § 48; on the contrary  $\phi(w)$  is regular at the origin, and can be developed in a MACLAURIN'S series. Expressing  $w$  in this series in terms of  $z$  we obtain :

$$(2) \quad f(z) = a_0 + a_1(z - a)^{\frac{1}{n}} + a_2(z - a)^{\frac{2}{n}} + \dots + a_m(z - a)^{\frac{m}{n}} + \dots$$

Here, as follows from the derivation, any one of the values of this  $n$ -valued function can be chosen for  $(z - a)^{\frac{1}{n}}$ ; the values of the remaining terms of the series are then no longer arbitrary, since in general we are to take for  $(z - a)^{\frac{m}{n}}$  the  $m$ th power of the value chosen for  $(z - a)^{\frac{1}{n}}$ . For every value of  $z$  considered,

the series (2) therefore represents  $n$  values of the function in accordance with the  $n$  values of  $(z-a)^{\frac{1}{n}}$ ; together they constitute the  $n$  branches of the function  $f(z)$  which are connected cyclically about  $a$ . Such a point is called a *branch-point* or *winding-point* of order  $(n-1)$ : we assign it to the domain in which we have defined the function, and ascribe to the function at this point the value  $a_0$ .

But if we cannot show that  $f(z)$  and  $\phi(w)$  remain less than a finite limit in the neighborhood of  $z=a$  and  $w=0$  respectively, we cannot apply MACLAURIN'S theorem for the development of  $\phi(w)$ ; but we can use LAURENT'S theorem for this purpose. In this way  $f(z)$  is developed in a series of powers of  $z-a$  whose exponents are positive and negative fractions with  $n$  as denominator. Such a point is said to be a *branch-point* and a *singular point* at the same time; it is, in fact, a pole or an essential singular point according as the development just mentioned contains a finite or an infinite number of terms with negative exponents.

We may also have branch-points at which infinitely many sheets are joined together; we have had an example of this in studying the logarithm. But we shall not enter here into further discussion of such points, as also points in whose neighborhood infinitely many branch-points are accumulated.

We now take up a question postponed in § 34, viz., the question as to the conformality of the representation determined by a regular function in the neighborhood of a point at which  $dw/dz=0$ . Without loss of generality we may suppose the point we are considering to be the origin of the  $z$ -plane and that the origin of the  $w$ -plane corresponds to it; let the development of  $w$  in powers of  $z$  have the form:

$$(3) \quad w = a_n z^n + a_{n+1} z^{n+1} + \dots, \quad (n > 1),$$

and let  $a_0$  be different from zero. If we then introduce an auxiliary variable  $s$  by the equation :

$$(4) \quad w = s^n,$$

we obtain

$$(5) \quad s = \sqrt[n]{a_n} z \left\{ 1 + \frac{a_{n+1}}{a_n} z + \dots \right\}^{\frac{1}{n}}.$$

The principal value of the  $n$ th root of the quantity in parenthesis is regular in the neighborhood of the origin (cf. I, § 61) ; hence in the neighborhood of  $z = 0$ ,  $s$  is a regular function of  $z$  whose derivative for  $z = 0$  is not zero but is equal to  $\sqrt[n]{a_n}$ . The relation between the  $s$ -plane and the  $z$ -plane is therefore conformal at the origin ; but on account of equation (4) and § 18 the angle at the origin in the  $w$ -plane is  $n$  times as large as the angle at the origin in the  $s$ -plane. And therefore the angle at the origin in the  $w$ -plane is  $n$  times as large as the corresponding angle at the origin in the  $z$ -plane ; in other words we have the theorem :

*If a function is regular at a point in the  $z$ -plane and if the first  $(n - 1)$ st derivatives of this function are equal to zero at this point, but the  $n$ th derivative is different from zero, then in the transformation from this plane to the  $w$ -plane, the angle at this point increases  $n$ -fold.*

According to X, § 46,  $z$  is then a regular function of  $s = w^{1/n}$  in the neighborhood of  $s = 0$  in whose development the coefficient of the first term is not equal to zero ; thus  $w = 0$  is a branch-point of order  $n - 1$  for the inverse function  $z(w)$ . Since these considerations are reversible, it follows that :

*If the development of a function  $z(w)$  in the neighborhood of an  $(n - 1)$ -fold branch-point  $\alpha$  begins with  $(w - \alpha)^{1/n}$  following a constant term  $a_0$ , then the angle at this point is reduced to its  $n$ th part in the transformation from the  $w$ -plane to the  $z$ -plane.*

To a line of the  $w$ -plane which has a definite tangent at the point  $w = \alpha$ , corresponds then a line of the  $z$ -plane, which has the point  $z = \alpha_0$  as an  $n$ -fold point with  $n$  separate tangents; these tangents form angles  $\pi/n$  with each other.

**EXAMPLES**

1. State the theorem concerning isolated singular points of analytic functions at which the function remains finite.

2. Assuming the theorem in Ex. 1, establish other facts about isolated singular points, and deduce the form of development of a function about a pole.

3. Given the function  $f(z) = \sum_{n=1}^{\infty} z^{n!}$ , show that the circle of convergence, that is, the unit circle about the origin, is a natural boundary.

HINT. — If  $q$  and  $r$  are integers, the point  $e^{\frac{2q\pi i}{r}}$  on the circle of convergence is an obstacle to the continuation. For, put  $z = \rho \cdot e^{\frac{2q\pi i}{r}}$  ( $\rho < 1$ ) and let  $\rho$  increase; then as  $\rho$  approaches 1, the part of the series from the  $r$ th term onwards, namely  $\sum_{n=r}^{\infty} \rho^{n!}$  approaches infinity. This would be impossible if the point  $e^{\frac{2q\pi i}{r}}$  were situated inside of any immediate continuation of the power series. It is thus clear that there are infinitely many obstacles on the circle of convergence and too that on any arc there are infinitely many obstacles.

**§ 70. Analytic Functions of Analytic Functions**

If  $z'$  is an analytic function of  $z$ :

(1) 
$$z' = \phi(z)$$

and if  $w$  is an analytic function of  $z'$ :

(2) 
$$w = f(z'),$$

the question arises whether

(3) 
$$w = F(z) = f[\phi(z)]$$

is an analytic function of  $z$  and in what sense it is such a function.

We have already disposed of the simplest case in X, § 38. If  $\phi$  is single-valued and regular in a domain  $S$  of the  $z$ -plane, and if all the values of  $\phi$  which belong to points of this domain fall in a domain  $S'$  of the  $z'$ -plane in which domain  $f$  is regular, then  $w$  is also regular in  $S$ .

But if  $\phi$  or  $f$  or both are many-valued functions, the question arises: When we give all their values to these two functions in (3), will the totality of values of  $w$  so obtained belong to one and the same analytic function of  $z$ , or to different functions of this kind? and in both cases: will this function (or these functions) be obtained completely in this way, or are there still other values belonging to it (or to them)? To answer this question we must follow the analytic continuation somewhat in detail; and according to XII, § 54, it will be sufficient to limit ourselves to closed paths in doing so.

Let then  $z_0$  be a value of  $z$  for which the function  $\phi$  takes on a value  $z'_0$  (along with other values). Let the function  $f(z')$  be defined for  $z'_0$  and let its value or one of its values be  $w_0$ . Let the corresponding elements of the function be denoted by  $(z'_0), (w_0)$ . The function-symbol  $f(z')$  includes then besides  $w_0$ , all the values which are obtained by allowing  $z'$  to take on all the values on arbitrary closed paths in its plane and continuing  $w$ , beginning with  $w_0$ , analytically as a function of  $z'$ ; on the contrary the function-symbol  $F(z)$  includes the values which are obtained by allowing  $z$  to take on the values on closed paths in its plane and in this way continuing  $w$  analytically as a function of  $z$ . The question as to whether the two functions are identical or different is thus reduced to the two following cases:

I. Can  $z'$  be continued along all the  $z$ -paths upon which  $F(z)$  can be continued? This is then and only then *not* the case

when  $\phi(z)$  has natural boundaries which are not such boundaries for  $F(z)$ .\* The function-symbol  $F(z)$  has then a wider meaning than  $f[\phi(z)]$ .

II. Can any closed  $z'$ -path be obtained by allowing  $z$  to describe a suitable, closed path in its plane? This is then not the case when  $z = \psi(z')$ , the inverse of the function  $z' = \phi(z)$ , is not single-valued. In this case the analytic function  $F(z)$  can include perhaps † only a part of the values of  $f[\phi(z)]$ . We have had an example of this in  $\log z^2$  in § 56;  $\sqrt[m]{z^{np}}$  is a second example.

The remaining values of  $f[\phi(z)]$  are classified as other analytic functions  $F_1(z)$ ,  $F_2(z)$ , ... so that  $f[\phi(z)]$  is thus divided into a (finite or an infinite) number of such functions.

(Cases I and II may both apply to the same function; then only a part of the values of  $f[\phi(z)]$  are identical with a part of the values  $F(z)$ .)

The relations become more complicated if we assume  $f$  to depend not upon one but upon two (or more) functions of  $z$ ,  $\phi(z)$ ,  $\chi(z)$ . But the discussion of functions of several complex variables is excluded from this book; let it be said, however, that in this case  $\phi$ ,  $\chi$  are to be continued *simultaneously* in order to obtain values of  $F(z)$  and thus we are not always free to associate two arbitrary values of  $\phi$  and  $\chi$ .

### § 71. The Principle of Reflection

The general method of analytic continuation developed in § 67 is not suited for actual application in investigating particular functions. It is best in such cases to resort to special

\* That this can happen is shown by the trivial example that  $f$  is the inverse of  $\phi$  and thus  $F(z) = z$ .

† This is not necessarily the case; the values of  $F$  considered can perhaps be obtained when  $z$  describes other paths;  $\sqrt[m]{z^n}$ , where  $m$ ,  $n$  are prime, is an example of this.

methods: an important method of this kind is discussed in this and the following paragraphs.

Let us fix in mind a very special case. Let a function  $f(z)$  be by definition regular in the interior of a domain  $A$  of the  $z$ -plane, a part of whose boundary is a piece of the axis of real numbers. If the function is also regular and real on this piece of the axis and if  $z_0$  is a point on this piece, its development in powers of

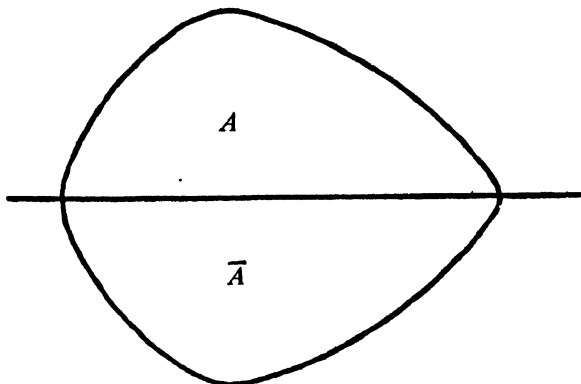

FIG. 43

$z - z_0$  has real coefficients, and therefore it takes on conjugate complex values at pairs of conjugate complex  $z$ -points. But we will not assume from the start that the function is regular on this piece of the axis nor even on only a part of this piece; we suppose only that as  $z$  approaches arbitrarily to a definite point  $x$  of this piece of the axis,  $f(z)$  converges to a definite *real* value  $f(x)$  in the limit, and that these values of  $f(x)$  together with the values of the function  $f(z)$  at interior points of  $A$  form a continuous function of the real variables  $x$  and  $y$ .\*

Let us now determine the points  $\bar{z}$  conjugate to the points  $z$

\* We do not discuss here whether this second supposition is a consequence of the first: concerning this see P. PAINLEVÉ, *Ann. de la fac. de Toulouse*, Vol. II (1888), p. 19.

of the domain  $A$ ; all these  $\bar{z}$ -points thus form a domain  $\bar{A}$  which is the *reflection* of  $A$  in reference to the axis of real numbers. Then by assigning to each point  $\bar{z}$  that value which is conjugate to the value of  $f(z)$  at  $z$ , we define a function which is regular in  $\bar{A}$ , viz.:

$$(1) \quad f_1(\bar{z}) = \overline{f(z)}.$$

Let  $\zeta$  be a point in the interior of  $A$ : it then follows according to the theorem of CAUCHY\* that:

$$(2) \quad \frac{1}{2\pi i} \int_{(A)} \frac{f(z)}{z - \zeta} \cdot dz = f(\zeta)$$

but that:

$$(3) \quad \frac{1}{2\pi i} \int_{(\bar{A})} \frac{f_1(\bar{z})}{\bar{z} - \zeta} \cdot d\bar{z} = 0.$$

We now add these two equations member by member. The parts of the two integrals taken along the piece of the axis of reals thus drop out since  $z = \bar{z}$ ,  $f(z) = f_1(\bar{z})$  along this piece of the axis, and the direction of integration is in the one case opposite to that in the other;  $f(\zeta)$  remains; it is expressed by an integral taken along the boundary of the domain  $(A + \bar{A})$ , viz.,

$$\frac{1}{2\pi i} \int_{(A+\bar{A})} \frac{f_2(\zeta)}{(\zeta - \zeta)} d\zeta$$

where  $\zeta = z$ ,  $f_2(\zeta) = f(z)$  along the part of the boundary belonging to  $A$  and  $\zeta = \bar{z}$ ,  $f_2(\zeta) = f_1(\bar{z})$  along that part belonging to  $\bar{A}$ . † This integral has the exact form of the CAUCHY'S integral; but such an integral represents a function regular in the whole domain and designated here temporarily by  $\phi(\zeta)$  (cf. cor. to I,

\* In order to apply CAUCHY'S theorem here we must apply it to a curve which lies entirely inside of  $A$ , and then pass from this to the boundary of the domain with the aid of III, § 29.

† The symbol for the variable of integration can be selected arbitrarily.

§ 36, also the first proof of I, § 50). The process thus shows that  $f(\zeta) = \phi(\zeta)$  in the domain  $A$ .

But if  $\zeta$  is a point in  $\bar{A}$  we have

$$(4) \quad \frac{1}{2\pi i} \int_{(A)} \frac{f(z)}{z - \zeta} dz = 0$$

and

$$(5) \quad \frac{1}{2\pi i} \int_{(\bar{A})} \frac{f_1(\bar{z})}{\bar{z} - \zeta} d\bar{z} = f_1(\zeta).$$

Proceeding as in the case above we find that this same regular function  $\phi(\zeta)$  is identical with  $f_1(\zeta)$  in the domain  $(\bar{A})$ . There is therefore a function regular in the whole domain  $(A + \bar{A})$ , which is identical with  $f(\zeta)$  inside of  $(A)$  and identical with  $f_1(\zeta)$  inside of  $\bar{A}$ ; but this means precisely that  $f_1(\zeta)$  is the analytic continuation of  $f(\zeta)$ . Hence the theorem:

I. *The analytic continuation of  $f(z)$  across this piece of the real axis is always possible under the given assumptions; it is performed by assigning conjugate values of the function to conjugate values of the argument.\**

The theorem may be easily generalized to the case where any other straight line of the plane is used instead of the axis; hence:

II. *If an analytic function takes on real values (in the sense defined at the beginning of the paragraph) along a piece of a straight line, it takes on conjugate complex values at such points which are reflections of each other in reference to that line.*

\* This particular continuation, important in investigations concerning conformal representation, is contained in a proposition due to SCHWARZ, *Crelle*, Vol. 70 (1869), pp. 106, 107, *Ges. Math. Abh.* Vol. II, pp. 66-68. Cf. also DARBOUX, *Theorie générale des surfaces*, Vol. I, § 130. — S. E. R.

§ 72. Conformal Representation of a Triangle bounded by Straight Lines on a Half-plane

The theorems of the previous paragraph may be applied to the solution of the following problem: to map a triangle bounded by straight lines in the  $w$ -plane conformally on a  $z$ -half-plane (or on a  $z$ -hemisphere). Let us suppose the possibility of the solution and designate by

$$(1) \quad z = \phi(w)$$

the function desired for the mapping. Primarily the problem implies that this function be regular inside of the triangle, that it remains continuous in approaching the sides of the triangle, and that it assumes real values on them. But these properties are sufficient according to II,

§ 71 to continue the function analytically beyond the sides of the triangle over the three other triangles, which are the reflections of the given triangle in reference to its sides. The same conclusion can then be applied to each side of each of the new triangles, etc., so that finally the whole RIEMANN'S surface of  $\phi(w)$  is constructed entirely from

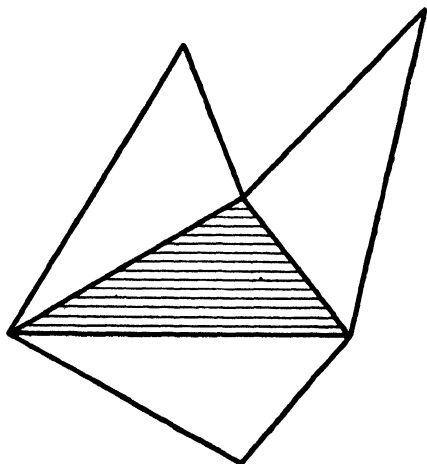

FIG. 44

triangles which are alternately congruent and symmetrical to the given one. In this way the triangles formed later overlap those formed earlier, even the original triangle, and the RIEMANN'S surface so formed will in general be composed of an infinite number of sheets. In order that the surface be one-

sheeted it is necessary that one vertex of the triangle shall not be a branch-point, and that therefore we shall again obtain the original triangle after an even number of reflections on the sides of the triangle intersecting at such a vertex. For this purpose it is necessary and sufficient that *each angle of the triangle be an aliquot part of  $\pi$* .

But when this condition is satisfied the plane is always covered uniquely by the alternately congruent and symmetrical repetitions of the original triangle. This is best illustrated by examining the possible, individual cases of which there are only a small number. For, if the angles of a triangle are  $\pi/l, \pi/m, \pi/n$ , where  $l, m, n$  are integers  $> 1$ , these integers must satisfy the equation

$$(2) \quad 1/l + 1/m + 1/n = 1.$$

This is at once the case when each  $= 3$  and the triangle is therefore equilateral. But if they are not all equal to 3, one must be smaller and hence  $= 2$ . Let  $l = 2$ ;  $1/m + 1/n$  is then  $= 1/2$ , and thus  $(m-2)(n-2) = 4$ , and therefore either  $m = 4, n = 4$ , or  $m = 3, n = 6$  ( $m = 6, n = 3$  is the same case). Therefore:

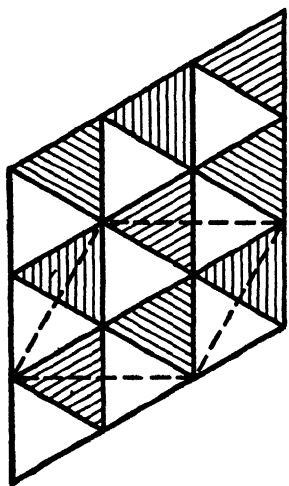

FIG. 45

1. *The surface of a triangle bounded by straight lines can be mapped conformally upon a half-plane in only three cases by means of a function which is single-valued in the whole plane, viz.: when the triangle is either equilateral, or right-angled isosceles, or half of an equilateral triangle.*

We notice now that a parallelogram is formed from eighteen of these alter-

nately congruent and symmetrical triangles in the first case, from eight of them in the second case, and from twelve in the third case; this parallelogram is such that further continuation always leads\* to congruent † parallelograms. That the plane is covered once without gaps by congruent parallelograms is only an elementary theorem.

The functions which determine the representation can be obtained as follows in every case (not merely for the three special cases mentioned above):

Let  $w = f(z)$  be the solution of

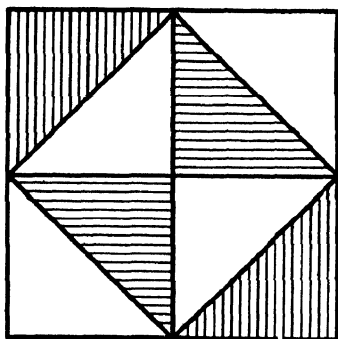

FIG. 46

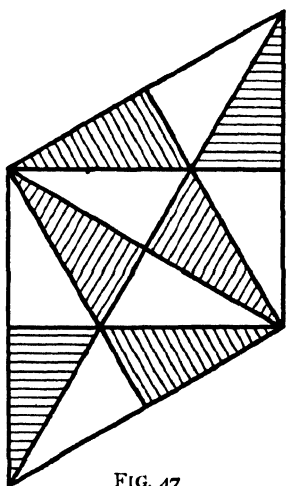

FIG. 47

equation (1): then the half-plane is mapped on a triangle similar to the given one by the function  $C_1w + C_2$  where  $C_1, C_2$  are arbitrary constants (cf. § 10). The indefiniteness arising in this way is eliminated by considering the function

$$(3) \quad \frac{d}{dz} \cdot \log \frac{dw}{dz}$$

instead of the function  $w$ ; this function (3) remains unchanged when  $C_1w + C_2$  is substituted for  $w$ . Without loss of generality we may further

\* The number eighteen of the first case can be reduced to six by constructing the parallelogram from parts of different triangles. This is designated in Fig. 45 by the dotted lines.

† Congruent also in reference to the position of the individual triangles in them which are indicated in the figures by hatching.

suppose that the three points  $0$ ,  $1$ ,  $\infty$  of the sphere taken in order correspond to the three vertices of the triangle; for, according to § 15 this can always be done previously by a linear transformation of the  $z$  variables. Then  $w$  must be a function of  $z$  which is regular in the neighborhood of every point of the  $z$ -sphere with the exception of the three points just named and which has a derivative different from zero (VI, § 34). The angle  $\pi$  of the  $z$  half-plane must be mapped upon the angle  $\alpha\pi$  of the triangle of the  $w$ -plane at the point  $z = 0$ ; hence at this point we must have

$$\begin{aligned} w - w_0 &= z^\alpha \cdot f(z) \\ \frac{dw}{dz} &= \alpha \cdot z^{\alpha-1} \cdot f_1(z), \\ (4) \quad \frac{d}{dz} \log \frac{dw}{dz} &= \frac{\alpha - 1}{z} + f_2(z), \end{aligned}$$

where  $f(z)$ ,  $f_1(z)$ ,  $f_2(z)$  are understood to be functions regular in the neighborhood of the origin. Similarly, in the neighborhood of the point  $1$ :

$$(5) \quad \frac{d}{dz} \log \frac{dw}{dz} = \frac{\beta - 1}{z - 1} + \text{a regular function};$$

and in the neighborhood of the point  $\infty$ :

$$(6) \quad \frac{d}{dz} \log \frac{dw}{dz} = -\frac{\gamma - 1}{z} + z^{-2} \cdot \text{a regular function}.$$

Therefore the function (3) has poles of the first order at the singular points  $0$  and  $1$ , it is otherwise regular over the whole sphere, and is zero at infinity; it is consequently a *rational* function according to VI, § 44, and is, in fact,

$$(7) \quad = \frac{\alpha - 1}{z} + \frac{\beta - 1}{z - 1}.$$

(The development of this function in the neighborhood of  $z = \infty$  takes the form (6) since  $\alpha + \beta + \gamma = 1$ .) Integrating (7) twice we obtain :

$$(8) \quad C_1 z w + C_2 = \int^z \frac{dz}{z^{1-\alpha} \cdot (z-1)^{1-\beta}}$$

as the solution of the problem; further discussion of this solution is beyond the bounds set for our purpose.

The limiting case  $\alpha = \frac{1}{2}$ ,  $\beta = \frac{1}{2}$  (and thus  $l = 2$ ,  $m = 2$ ,  $n = \infty$ ) leads, if we put  $z = \zeta + 1$ , to the mapping of a half-strip on the half-plane by the function  $w = \sin^{-1} \zeta$  investigated in §§ 42 and 62 *d*.

### § 73. Generalization of the Principle of Reflection; Reflection on a Circle

The theorem of § 71 is capable of a very wide generalization as worked out by H. A. SCHWARZ. Let the two equations

$$(1) \quad x = \phi(t), \quad y = \psi(t),$$

in which  $\phi, \psi$  signify at present real regular functions of the real variable  $t$  (limited to a definite interval), determine a "regular arc of a curve"; we can then, according to I, § 38, give complex values to this variable  $t$  without affecting the convergency of the series for  $\phi$  and  $\psi$ . Therefore by the equation

$$(2) \quad z = x + iy = \phi(t) + i\psi(t),$$

a domain of the  $t$ -plane which lies on both sides of a definite piece of the real  $t$ -axis, is mapped on a domain of the  $z$ -plane which lies on both sides of the given regular arc of a curve; and we can restrict the first domain in such a way that the latter one does not overlap itself, (X, § 46). If the  $z$ -points are now arranged in pairs corresponding to conjugate values of  $t$  by means of (2), we define in this way in the last named domain a reversibly unique arrangement of the points  $z$  in pairs.

I. *This arrangement is only dependent upon the given arc of a curve itself, and independent of the way it is represented by equations of the form (1).*

In order to obtain another way of representing the same arc of a curve, we replace  $t$  in equation (1) by a real, regular function of another real variable  $\tau$ , and then give to  $\tau$  complex values also; in this way conjugate complex values of  $t$  correspond to conjugate complex values of  $\tau$  according to § 71. Accordingly we define as follows:

II. *Two points of the  $z$ -plane which correspond to conjugate points of the  $t$ -plane are called reflected images of each other in reference to the given regular arc of a curve.*

Hence the following more general theorem is obtained from the special one I, of § 71:

III. *Let  $f(z)$  be a function regular by definition inside of a domain of the  $z$ -plane, to whose boundary a regular arc of a curve*

$$x = \phi(t), \quad y = \psi(t)$$

*belongs; let it be further known that  $f(z)$  converges to a definite real value  $\chi(t)$  in the limit as  $z$  approaches arbitrarily to a definite point  $t$  of this arc, and that these limits together with the given values of the function form a continuous function of  $x$  and  $y$ . Then the function  $f(z)$  may be continued analytically beyond that arc of the curve, and in so doing it takes on conjugate complex values at points which are reflected images of each other in reference to that arc.*

If in particular the given arc is an arc of the unit circle, we can put

$$\phi(t) = \frac{1-t^2}{1+t^2}, \quad \psi(t) = \frac{2t}{1+t^2}$$

and hence (cf. 3, § 15):

$$x + iy = \frac{(1+it)^2}{1+t^2} = \frac{1+it}{1-it}$$

If we now give to  $t$  in this equation two conjugate values  $u + iv$  and  $u - iv$  and designate the corresponding values of  $x + iy$  by  $x_1 + iy_1$  and  $x_2 + iy_2$  respectively, we obtain :

$$x_1 + iy_1 = \frac{1 - v + iu}{1 + v - iu},$$

$$x_2 + iy_2 = \frac{1 + v + iu}{1 - v - iu},$$

and therefore :

$$x_2 - iy_2 = \frac{1 + v - iu}{1 - v + iu} = \frac{1}{x_1 + iy_1}.$$

But that is exactly the relation between the two points  $(x_1, y_1)$  and  $(x_2, y_2)$ , which we designated earlier as reflection on the unit circle (cf. equation (7), § 11); hence we say :

IV. *The reflection on the unit circle investigated earlier is a special case of the reflection on an arbitrary regular arc of a curve defined by III.*

**§ 74. Conformal Representation of a Triangle bounded by Arcs of Circles upon the Half-plane**

In § 72 we made use of the special theorem of § 71 to investigate the conformal mapping of a triangle bounded by straight lines upon the half-plane; the more general theorem of § 73 is now used to discuss the same problem for a triangle bounded by arcs of circles. However, the present problem is treated less exhaustively than the other one; we limit the discussion to emphasizing a few particular points and solving an easy example.

If the converse of the function used for the mapping is to be single-valued, the angles of the triangle must be aliquot parts of  $\pi$  in this case also. But the relation (2), § 72 is not necessarily satisfied here; we have, consequently, three cases to discuss, viz. :

I. If  $1/l + 1/m + 1/n = 1$ , we show geometrically (cf. Fig. 48) that the three circles to which the arcs bounding the triangle belong intersect in a point. If by means of a linear transformation we pass from the  $w$ -plane to a  $w'$ -plane in which the point  $w' = \infty$  corresponds to this point of intersection, a triangle bounded by straight lines in the  $w'$ -plane will then correspond to the given triangle of the  $w$ -plane; but this is simply the previous case already discussed.

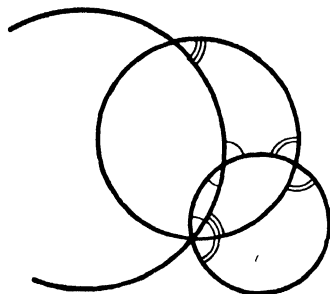

FIG. 48

II. If  $1/l + 1/m + 1/n > 1$ , we transfer the triangle to the sphere by stereographic projection; it can then be shown geometrically that the planes of the three bounding circles intersect in a point *inside* of the sphere. We can now find infinitely many collineations of space of the kind spoken of in § 16, determined by linear transformations of the  $w$ -variables, which transfer the above point of intersection to the *center* of the sphere; if we assume any one of these, the triangle under consideration is transformed into a "spherical triangle" (in the ordinary sense of that word) which is bounded by arcs of three *great* circles of the sphere, and the reflections on the sides of the triangle defined in the previous paragraph are thus converted into reflections with reference to the planes of these sides (cf. XI, § 13) in the usual, optical sense of the word reflection. Two successive reflections of this kind are together equivalent to a rotation of the sphere about the line of intersection of the two planes through twice the angle which these planes make with each other. *Therefore the figure formed from the alternately symmetric and congruent repetitions of the original triangle must have the property that it is trans-*

formed into itself by a definite rotation of the sphere about its center.

The inequality (II) is satisfied by integral values of  $l, m, n$  in only the following ways :

1.  $l = m = 2, n$  arbitrary,
2.  $l = 2, m = 3, n = 3, 4, \text{ or } 5$  ;

the case  $l = 2, m = 3, n = 3$

will be discussed somewhat in detail.

The spherical excess of a triangle having the angles,  $\pi/2, \pi/3, \pi/3$  is

$$(I) \quad \pi/2 + \pi/3 + \pi/3 - \pi = \pi/6 ;$$

its area is accordingly equal to one twenty-fourth of the total surface of the sphere. When it is therefore possible to cover the whole surface of the sphere once without gaps by alternately symmetric and congruent repetitions of the given triangle, we shall need exactly twenty-four such triangles for this purpose. In fact the sphere is so covered by dividing each face of a regular tetrahedron into six triangles by drawing the medians in each face, and then projecting the triangles so obtained from the center of the tetrahedron upon the surface of the circumscribing sphere. When such a triangle is mapped upon a half-plane in such a way that its vertices correspond to the points  $z = 0, 1, \infty$  respectively, the function  $z$  of  $w$  by which the mapping is accomplished must have the following properties (its existence always presupposed) :

1. At all points  $w$  which are not vertices of the triangle, the function must be regular and have a derivative different from zero.

2.  $w - w_0$  must be a regular function of  $\sqrt{z}$  at the vertices of the triangle  $w_0$  which correspond to the point  $z = 0$ , since an angle  $\pi/2$  on the  $w$ -sphere here corresponds to an angle  $\pi$  of

the  $z$ -sphere;  $z$  is therefore a regular function of  $w$  which has a zero of order two at  $w_0$ .

3.  $w - w_1$  must be a regular function of  $\sqrt[3]{z-1}$  at the vertices of the triangle  $w_1$  which correspond to the point  $z = 1$ , and therefore  $z - 1$  is a regular function of  $w$  which has a zero of order three at  $w_1$ .

4.  $w - w_\infty$  must be a regular function of  $z^{-\frac{1}{3}}$  at the vertices of the triangle  $w_\infty$  which correspond to the point  $z = \infty$ , and therefore  $z$  is a function of  $w$  which has a pole of order three at  $w_\infty$ .

Accordingly,  $z$  is a function of  $w$  which is regular over the whole  $w$ -sphere with the exception of particular poles, that is, according to VI, § 44 it is a *rational* function of  $w$ . As such it is already determined by the properties 1, 3, 4, except as to a constant factor; the problem is then solved when we have so determined this constant factor that the property 2 is also satisfied.

The middle points of the edges of a tetrahedron are the vertices of a regular octahedron; we can then think of them as so arranged that the points  $w_0$  corresponding to them on the sphere fall at

$$0, \infty, +1, +i, -1, -i,$$

and are therefore (excepting  $w = \infty$ ) the roots of the equation:

$$(2) \quad f_1(w) \equiv w(w^4 - 1) = 0.$$

The vertices and the middle points of the sides of the tetrahedron give then points on the sphere all three of whose space coördinates  $\xi, \eta, \zeta - \frac{1}{2}$  (cf. § 13) have the absolute value  $\frac{1}{2\sqrt{3}}$ ; we may

suppose that the former have an even number of negative coördinates and that the latter have an uneven number of such coördinates. Then the arguments  $w_1$  of the first [(6), § 13] become:

$$\frac{1+i}{\sqrt{3}-1}, \quad -\frac{1+i}{\sqrt{3}-1}, \quad \frac{1-i}{\sqrt{3}+1}, \quad -\frac{1-i}{\sqrt{3}+1},$$

that is, the roots of the equation :

$$(3) \quad f_2(w) \equiv w^4 - 2i\sqrt{3}w^2 + 1 = 0;$$

the arguments  $w_\infty$  of the last become :

$$\frac{1-i}{\sqrt{3}-1}, \quad -\frac{1-i}{\sqrt{3}-1}, \quad \frac{1+i}{\sqrt{3}+1}, \quad -\frac{1+i}{\sqrt{3}+1},$$

that is, the roots of the equation :

$$(4) \quad f_3(w) \equiv w^4 + 2i\sqrt{3}w^2 + 1 = 0.$$

A rational function  $z - 1$  of  $w$  which satisfies the conditions 1, 3, 4 is therefore :

$$(5) \quad z - 1 = a \frac{(f_2(w))^3}{f_3(w)} = a \frac{w^4 - 2i\sqrt{3}w^2 + 1}{w^4 + 2i\sqrt{3}w^2 + 1};$$

in order to satisfy also the relation (2) we must have two coefficients  $a, b$  satisfying the identity :

$$f_3^3 + af_2^3 = bf_1^2.$$

We find :

$$(6) \quad \begin{aligned} f_3^3 - f_2^3 &= 6(w^4 + 1)^2 2i\sqrt{3}w^2 + 2(2i\sqrt{3}w^2)^3 \\ &= 12\sqrt{3}iw^2[(w^4 + 1)^2 - 4w^4] = 12\sqrt{3}if_1^2. \end{aligned}$$

Hence, the desired function by which the given triangle bounded by arcs of circles is mapped upon the half-plane is :

$$(7) \quad z = 12\sqrt{3}i \cdot \frac{f_1^2}{f_3^3} = 1 - \frac{f_2^3}{f_3^3};$$

further, this function has a two-fold zero at infinity also (which was not considered).\*

\* Concerning the case II cf. F. KLEIN, *Vorlesungen über das Ikosaeder*, Leipzig, 1884.

III. The third case  $1/l + 1/m + 1/n < 1$  leads to transcendental automorphic functions; we cannot enter into a further discussion of this case since the object of this introduction has been obtained, coming as we now have to the threshold of that province in the theory of functions where some of the most appreciated present-day problems are to be found.

### MISCELLANEOUS EXAMPLES

1. Prove that every function  $w = f(z)$  determines a transformation which leaves angles unchanged over any region throughout which  $f(z)$  is regular. What peculiarity occurs in the neighborhood of a branch-point of  $f(z)$ ?

2. Construct the RIEMANN'S surface for the inverse of the function  $w = z^4 + z^2$  and find the images of its sheets.

3. If  $f(z)$  is analytic throughout a certain simply connected region, prove that

$$F(z) = \int_a^z f(\xi) d\xi$$

is also analytic there,  $a$  being a fixed point of the region.

4. Show that if  $f(z)$  is analytic in a certain region  $S$  and if  $f'(z)$  vanishes at every point of  $S$ , then  $f(z)$  is a constant.

5. By taking the integral  $\int \frac{e^{iz}}{z} dz$

along a suitable contour and applying CAUCHY'S integral theorem, obtain the formula

$$\int_0^{\infty} \frac{\sin x^2}{x} dx = \frac{\pi}{4},$$

and hence

$$\int_0^{\infty} \frac{\sin x}{x} dx = \frac{\pi}{2}.$$

6. By means of the integral

$$\int \frac{e^{iz}}{\sqrt{z}} dz$$

taken along a suitable path, show that

$$\int_0^{\infty} \frac{\cos x}{\sqrt{x}} dx = \int_0^{\infty} \frac{\sin x}{\sqrt{x}} dx;$$

and hence by means of the same integral taken along another path, show that the value of these integrals is  $\sqrt{\frac{\pi}{2}}$ .

7. Prove that, if  $f(z)$  is analytic at the point  $z = a$  and  $f'(a)$  does not vanish, then the equation

$$w = f(z)$$

can be solved for  $z$ , and establish the essential properties of the solution.

8. If  $\phi(t)$  is a function of  $t$  defined along a regular curve  $C$  in the complex  $t$ -plane, and if  $\phi(t)$  is continuous along this curve, discuss the function of  $z$  defined by the integral:

$$\int_C \frac{\phi(t) dt}{t - z}.$$

9. Deduce CAUCHY'S integral formula. Name some of the most important theorems that are proven by means of this formula, and also some that follow indirectly from it.

10. Obtain an expression for  $|\sin z|$  in terms of  $x$  and  $y$ , where

$$z = x + iy.$$

Hence, discuss the convergence of the series

$$\frac{\sin z}{5} + \frac{\sin 2z}{5^2} + \frac{\sin 3z}{5^3} + \dots$$

For what values of  $z$  does this series represent an analytic function?

**11.** Regarding the function  $f(z)$  it is known that its pure imaginary part is never negative when  $z$  lies in the neighborhood of the point  $a$ ; while the function  $\phi(z)$  is in absolute value greater than  $1/2$  for such values of  $z$ . Both functions are single-valued and analytic near  $a$  with the exception of the point  $a$  itself, at which they are not defined. What can you say about the character of the function

$$\frac{f(z)}{\phi(z)}$$

in this neighborhood?

**12.** If a function is analytic in the entire plane and becomes infinite at infinity, will it necessarily vanish for some value of  $z$ ?

**13.** Discuss the linear transformation of the ARGAND plane into itself when the fixed points are distinct and finite.

**14.** Show that to every rotation of a sphere about a diameter, corresponds a linear transformation of the plane of stereographic projection.

**15.** What singularities may an algebraic function have? Prove your answer to be correct.

**16.** State carefully a sufficient condition that an analytic function be algebraic.

**17.** Discuss the function defined by the integral

$$w = \int_0^z \frac{dz}{z^{2/3}(1-z)^{2/3}}.$$

On what region of the  $w$ -plane does this function map the upper half of the  $z$ -plane?

**18.** How would you prove that every algebraic equation has a root?

**19.** Give two definitions of the function  $e^z$  for complex values of the exponent.

Restricting yourself to one of these definitions, show that the function is analytic and satisfies the functional relation :

$$f(z_1 + z_2) = f(z_1) \cdot f(z_2).$$

**20.** State and prove the theorem about the inverse of an analytic function being an analytic function.

**21.** Prove that a function  $f(z)$  which is analytic in all finite points of the  $z$ -plane, and which remains finite for the whole plane is a constant.

**22.** The functions  $f_1(z), f_2(z)$  are both analytic throughout a region  $T$  having an isolated boundary point  $z = a$ , and they have poles at the point  $a$ . What can you say concerning the order of the poles of the function

$$F(z) = f_1(z) + f_2(z)$$

at the point  $z = a$ ?

**23.** Show that, if a function  $f(z)$  is analytic throughout a region  $T$ , one of whose boundary points is the isolated point  $z = a$ , and if  $f(z)$  remains finite in the neighborhood of  $a$ , then  $f(z)$  approaches a limit when  $z$  approaches  $a$ .

**24.** A regular hexagon is reflected on its sides; show that  $a + bv + cv^2$  represents the vertices of the resulting configuration; if  $a + b + c = \pm 1$  ( $a, b, c$  integers), what particular hexagon is it? Discuss the case for  $a + b + c = \pm \alpha$ . Is the plane covered simply or multiply?

**25.** What does 
$$\begin{vmatrix} 1 & 1 & 1 \\ a & b & c \\ x & y & z \end{vmatrix} = 0$$
 mean if  $a, b, c; x, y, z$  are sets

of points in the plane?

**26.** Prove that if a function is analytic throughout a region, and its vanishing points there are not isolated from one another, the function must vanish at every point of the region.

What is the importance of this theorem when we come to the question of extending the definition of functions from real to complex values of the argument? Illustrate by means of the functions  $e^z$ ,  $\sin z$ .

**27.** State accurately the three definitions of analytic functions which depend respectively on the process of differentiation, integration, and development in series.

Adopting whichever of these definitions you choose, state accurately and prove the theorem which says that a uniformly convergent series represents an analytic function.

**28.** If  $f(z)$  has at each point of a simply connected region  $n$  distinct values, each of which varies continuously with  $z$ , prove that if the point  $z$  describes any closed contour in this region, none of the values of  $f(z)$  will be interchanged.

What information does this theorem give us concerning the RIEMANN'S surface of the two-valued functions

$$\sqrt{\sin z}, \quad \sqrt{\csc z}, \quad \sqrt{e^z}?$$

**29.** Construct the RIEMANN'S surface for the inverse of the function

$$z = 3w^4 + 4w^3.$$

**30.** Let  $a$  be a point within a certain two-dimensional region  $B$ , and let  $f(z)$  be a function single-valued and continuous at every point of  $B$ , which vanishes at  $a$ . Prove that if  $f(z)$  is known to be analytic at every point of  $B$  except  $a$ , it must also be analytic at  $a$ .

HINT.—Use that definition of an analytic function which depends upon the process of integration.

If  $\phi(z)$  is analytic at every point of  $B$  except  $a$ , at which point it is not defined, and if  $\phi(z)$  does not become infinite as

we approach  $a$ , prove that it is possible to define  $\phi$  at the point  $a$  in such a way that  $\phi(z)$  is analytic at  $a$ .

HINT.—Consider the function  $(z - a)\phi(z)$ .

**31.** Is  $z = 0$  a branch-point for the function  $w$  of  $z$  defined by the equation

$$w^{10} = z^{11} - z^{10}?$$

Is  $z = \infty$  a branch point? Construct the RIEMANN'S surface for the function.

**32.** The function  $f(z)$  has a branch-point of the  $(q - 1)$ st order in  $z = a$ . When is  $f(z)$  said to have a pole in  $a$ ? Define the order of the pole.

Will the integral

$$\int_{z_0}^z f(z) dz$$

necessarily have a pole in  $a$ ? State precisely the condition.

**33.** If the analytic function  $w = f(z)$  has a branch-point of finite order in  $z = a$ , what is the condition that the neighborhood of  $a$  be mapped on a single-leaved neighborhood of the point  $w = f(a)$ ? Discuss both the case that  $f(a)$  is finite and the case  $f(a) = \infty$ .

**34.** Prove that if  $z = x + iy$ , the function

$$f(z) = e^z (\cos y + i \sin y)$$

is an analytic function of  $z$ . Has this function any singular points? If so, what are they? Are there any points of the  $z$ -plane where, in the transformation to the  $w$ -plane,  $w = f(z)$  fails to be conformal? If so, what are they?

What are the images in the  $w$ -plane

(a) of the lines parallel to the axis of reals in the  $z$ -plane;

(b) of the lines parallel to the axis of imaginaries in the  $z$ -plane?

What happens to the image of a strip in the  $z$ -plane, bounded by two lines parallel to the axis of reals, as the breadth of this strip increases indefinitely?

What can be inferred from the result you have just found concerning the inverse of the function  $f(z)$ ?

The following four are *simple examples of conformal representation* due to SCHWARZ, *Werke*, Vol. II, p. 148.

35. A region bounded by two arcs of circles through the points  $z_1, z_2$  in the  $z$ -plane is mapped on half of the  $w$ -plane by the function

$$w = \left( \frac{z - z_1}{z - z_2} \right)^{1/\lambda}$$

where  $\lambda\pi$  is the angle at which the arcs intersect.

36. A region bounded by three arcs of circles which intersect at angles  $\pi/2, \pi/2, \lambda\pi$  is transformed by

$$w = [(z - z_1)/(z - z_2)]^{1/\lambda}$$

into a semi-circle, where  $z_1, z_2$  are the points of intersection of those two arcs which include the angle  $\lambda\pi$  ( $\lambda \neq 0$ ).

A special case of the above region is the sector of a circle. For this  $z_2 = \infty$ , and the transformation is replaced by

$$w = (z - z_1)^{1/\lambda}.$$

37. If in the preceding example  $\lambda$  vanishes, the transformations which convert the triangle bounded by arcs of circles into a sector are of a different character. Let  $z_1$  be the point at which the two arcs touch; the remaining arc produced will pass through  $o$ . If  $\lambda\pi$  be the angle which the real axis makes with the tangent at  $z_1$ , the transformation

$$w = e^{\lambda\pi i}/(z - z_1)$$

is equivalent to a turn of the tangent through an angle  $\lambda\pi$  (thus becoming parallel to the axis) followed by a quasi-inversion with

regard to  $z_1$  (that is, a combination of reflection and inversion—a term due to CAYLEY). The resulting region is bounded by two lines parallel to the real axis in the  $w$ -plane, and by part of a line parallel to the axis of imaginaries. The further transformation

$$w' = e^{-w}$$

changes the two parallel straight lines into two straight lines through a point, and the remaining straight line into an arc of a circle with this point as center. The resulting region is a circular sector.

**38.** The transformation  $w = (z - i)/(z + i)$  determines a conformal representation of the positive half of the  $z$ -plane upon a circle in the  $w$ -plane whose center is at the origin and whose radius is unity.



# INDEX

(The numbers refer to pages.)

- $A^z$ , principal value of, 309.  
ABEL'S theorem on multiplication of series, 212.  
Abscissa, 12.  
Absolute convergence of a series, 170; of a power series, 202.  
Absolutely convergent series, sum of an, 170.  
Absolute value, definition of, 14; of a sum, 17.  
Absolute value and amplitude of a complex number, 218; of an integral, 155; of a product, 19; of a quotient, 21.  
*Ableitungsweise monoton*, 140.  
Accumulation point, 128.  
Addition, geometrical representation of, 16.  
Addition and subtraction of number-pairs, 3.  
Addition theorem for exponential functions, 218; for trigonometric functions, 218.  
Aggregate of points, 127.  
Algebra, an, of number-pairs, 3; double, 3; geometrical representation of double algebra, 3.  
Algebraic addition theorem, 275.  
Amplitude, definition of, 15; change in value of, 284; and absolute value of a complex number, 218; many-valuedness of the, 21; of a product, 19; of a quotient, 21; of the double ratio, 70; principal value of the, 284; the, a continuous and a single-valued function of position, 286, 290, 291, 293; of the logarithm, 296.  
Analysis situs, 328.  
"Analytic about," "regular at," 282.  
Analytic continuation, 382, 384; across a line, 402; of an integral, 385.  
Analytic function, an, definition of, 384, 386.  
Analytic functions of analytic functions, 397; single-valued, 167.  
Angles, preserved, 41, 43; in stereographic projection, 48; opposite: in sense, 42, 43.  
Approximation, degree of, 153, 169.  
ARGAND, 12.  
Arithmetic, general, of real numbers, 1, 2.  
Assemblage of points, 127.  
Associative law, the, 5, 10, 16.  
Automorphic function, definition of, 84; symmetric, 92; example of, 106, 113.  
Axis, of real numbers, 13; of pure imaginary numbers, 13; of reals, reflection on, 39.  
Behavior of a function at infinity, 229.  
Bilinear transformation, substitution, 54.  
Binomial theorem, the, 221.  
BOCHER, 232, 282.  
BOREL, 235.  
BOREL, theorem, the HEINE-, 162.  
Boundary, natural, and singular points, 389, 393; a natural, a line of singularities is, 391; natural, not a cut, 391; point of a set of points, 137.  
Bounds, upper, lower, 127, 128; least upper, 128.  
Branch-cut, cut, bridge, 321.  
Branch-point, definition of, 292, 321, 395; examples of, 324-326; of many-valued functions, 393; when a pole, zero, essential singularity, 335; when a singular point, 395.  
Bridge, branch-cut, cut, 321.  
CANTOR, 131; DEDEKIND axiom, 3.  
Cartographic modulus, 183.

- Cartography, 47.  
 Cassinian oval, 373.  
 CAUCHY, 168, 178, 179, 199, 203, 213, 267, 271, 401.  
 CAUCHY-RIEMANN differential equations, 176, 179, 181.  
 CAUCHY'S theorems on integration, 190, 195, 199, 247; on residues, 236; applied to Riemann's surfaces, 333.  
 CAYLEY, 43, 421.  
 Change of amplitude, 284.  
 CHAPMAN, 23.  
 Circle of convergence, 199, 201; of a power series, 202.  
 Circle transformation, 54, 56; unit circle, 15.  
 Circuits about the origin, 288.  
 Circular points at infinity, 70.  
 Class of points, 127.  
 Classification of integrals by discontinuities, 352.  
 Closed segment, 138; set of points, 138.  
 Cluster point, 128.  
 Coefficients, of a power series, 206-210; method of undetermined, 207.  
 Coincidence of two power series, 207; of two functions, 208, 384.  
 Collection of points, 127.  
 Collinear points, three, 26.  
 Collineations of space, 77, 79, 80, 410.  
 Commutative law, 5, 7, 16.  
 "Complete" equation, definition of a, 299.  
 Conformal function, 170; continuity of a, 171.  
 Complex numbers, conjugate, 15, 19; geometrical representation of,  $r$ , 12; multiplication of, 10; on the helicoid, 291; on the sphere, 51; real, pure imaginary parts of, 10; units of, 8.  
 Complex quantity, 9.  
 Condensation point, 128.  
 Confocal parabolas, 85.  
 Conformal representation, 28, 41, 43, 182; breaks down, 184; by singly periodic functions, 224; by the logarithm, 304; by  $\tan^{-1} z$ , 314; of a triangle on the half-plane, 403, 409; of the half-plane on a circle, 421; where  $dw/dz = 0$ , 395.  
 Congruent figures, 30, 31.  
 Conjugate complex numbers, 15, 19.  
 Connected, domain, simply, 142; segment, 138; set of points, 138.  
 Connectivity of the surface for  $\sqrt{z}$ , 328.  
 Constant, definition of a, 28; when a function is, 230.  
 Construction of the RIEMANN'S surface, general, 385.  
 Continuation, analytic, 382, 384.  
 Continuity, 127; at infinity, 173; at a point, 131; at a pole, 172; in a domain, 145; of complex functions, 171; of functions of two variables, 143, 144; of a rational function, 133, 170, 172; on an interval, 131; uniform, 132.  
 Continuous function, a = a power series, 203; continuous mapping, 148, 151.  
 Contour, rectangular, 158.  
 Convergence, absolute, of a series, 170; absolute, of a power series, 202; circle of, 199, 201; of an infinite series, 169, 170; of a power series, 201; of a product of two series, 212; permanent, of a power series, 201; unconditional, 170; uniform, 155, 156, 200, 202, 203.  
 Convergent sequence, limit of a, 168.  
 Coördinates of a point, 12; polar, 13.  
 Correspondence, one-to-one, 12, 13, 29, 127.  
 Cosine, 216-221; a symmetric automorphic function, 226; period of the, 222.  
 Cube roots of unity, 25, 72.  
 Curve, 136; = a set of points, 136, 138, 139; general definition of a, 139, 140; parametric representation of a, 139; simple, 140.  
 Curvilinear integral, 156, 158, 189.  
 Cut, 321; Dedekind, partition, 128; not a natural boundary, 391.  
 DARBOUX, 152, 402.  
 Decomposition into partial fractions, 268.  
 DEDEKIND-CANTOR axiom, 3.  
 DEDEKIND cut, partition, 128.  
 Definitely infinite, 255, 256.  
 Deformation of the surface for  $\sqrt{z}$ , 329.  
 Degenerate transformation, 55.

- Degree of approximation, 153, 169; of a function, 99, 102; of a rational function, 102.
- DE MOIVRE'S theorem, generalization of, 309.
- Dense in itself, a set of points, 138.
- Derivatives, definition, 148; higher, successive, 179; independent of approach, 175, 176, 178; logarithmic, 240, 374; of a determinant, 166; of a rational function, 174; of an integral, 206; of a power series, 149, 203; partial, 150; progressive, regressive, 163, 165; successive, of a power series, 204; successive, of a regular function, 204; term by term, 149, 156.
- Derived, function, 149; sets of points, 131.
- DESCARTES, 12.
- Determinant, derivative of a, 166; of a transformation, 55, 65.
- Development, in a circular ring, 249, 253; near a pole, 229; in a strip, 257; in a power series, 199, 206; in a power series, unique, 207.
- Diametral, two complex numbers, 53, 80.
- Differential equations, CAUCHY-RIEMANN, 176, 179, 181; partial, 280.
- Differentiation, the inverse of integration, 155, 192.
- Direct similarity transformation, 35; direct circle transformation, 56.
- Discontinuity, removable, 103, 228, 252.
- Discontinuous, finite group, 113.
- Displacement (a translation), 30, 33.
- Distributive law, 7.
- Division by zero, 45; of complex numbers, 20, 21; of a line segment, harmonic, 61; of number-pairs, 6.
- Domain, 140; improper, 141; mapped continuously, 148, 151; simply connected, 142.
- Double algebra and its geometrical representation, 3.
- Double ratio, amplitude of, 70; invariant, 65, 72; of four points, 69, 70.
- $e^z$ , 216; is a symmetric automorphic function, 225; fundamental region of, 225.
- Electrical potential, 187.
- "Element" of the analytic function, 384.
- Elliptic linear substitution, 94, 95.
- Equation, a complete, 299; of  $n$ th degree has  $n$  roots, 242; has no more than  $n$  roots, 99.
- Equator on sphere, 51.
- Equatorial plane, reflection on, 51.
- Equianharmonic points, 72.
- Equipotential, lines of, 187.
- Essential singularity, definition of, 389, 390, 392; at a branch-point, 335.
- EULER, 81, 217.
- EULER'S relations, 217, 316.
- Even, odd functions, 272.
- Expansion (cf. also development); in a circular ring, 249, 253; in a power series, 199; in a strip, 257.
- Exponential function, 216-221, 279; addition theorem for, 218; periodicity of, 222.
- Finite discontinuous group, 113.
- Fixed (invariant) points of a transformation, 33; of the linear fractional transformation, 57, 64.
- Flächenstücke (region), 136.
- Flow, lines of, 187; of a fluid, 185.
- FORSYTH, 142, 261.
- FOURIER'S series, 257.
- Fractional numbers, 2.
- FRESNEL integrals, 215.
- Function, automorphic, 84; example of automorphic, 106, 113.
- Function, behavior at infinity, 104, 229.
- Function, complex, 170.
- Function, constant, when, 230.
- Function, continuity of a rational, 133, 170, 172.
- Function, continuous where finite, 255.
- Function, continuous = a power series, 203.
- Function, definition and history of, 28, 29, 178.
- Function, definition of an analytic, 384, 386.
- Function, definition of a rational, 28, 29, 167, 231, 392.
- Function, definition of a regular, 178.
- Function, degree of a rational, 103.
- Function, derivative of a rational, 174.

- Function, "element" of the, 384.  
 Function, even, odd, 272.  
 Function, exponential, 216-221, 279.  
 Function, generalization of the transcendental, 216.  
 Function, holomorphic, 252.  
 Function, infinite value of  $a$ , 173.  
 Function, linear fractional, 54.  
 Function, linear integral, 32-38.  
 Function, map of a rational, 173.  
 Function, mapping with a regular, 182.  
 Function, monogenic, 178.  
 Function,  $n$ -valued at a point, 242.  
 Function, order of the rational, 102, 103.  
 Function, periodic, 84, 222, 284.  
 Function, rational, the, indeterminate, 45, 103, 174, 228.  
 Function, rational integral, 29, 98, 231, 233, 392.  
 Function, rational, of  $z$  and  $s = \sqrt{z}$ , 331.  
 Function, reciprocal of a rational, 172, 173.  
 Function, regular = a power series, 203.  
 Function, regular, expanded in a power series, 199.  
 Function, regular, near a singular point, 227, 247, 254.  
 Function, regular, on the RIEMANN'S surface, 335.  
 Function, single-valued analytic, 167.  
 Function, single-valued on the RIEMANN'S surface, 333.  
 Function, single-valued on the sphere, 389.  
 Function, singly periodic, 224, 268, 273.  
 Function, successive derivatives of a regular, 204.  
 Function, sum of all orders of a rational, 106, 242.  
 Function, symmetric automorphic, 92.  
 Function, transcendental, 124, 167, 282, 392.  
 Function, transcendental integral, 201, 392.  
 Function, transcendental integral, at infinity, 233.  
 Function, trigonometric, 216-221.  
 Function, value of a periodic, 233.  
 Function, value of a rational at infinity, 105, 173.  
 Function, value of a regular in a domain, 106.  
 Function, when  $\infty$  is a pole of a rational, 105.  
 Function, when  $\infty$  is a zero of a rational, 106.  
 Function, with removable discontinuity, 228.  
 Functions, zeros and poles of a rational, 242.  
 Function,  $\sqrt[n]{z}$ , the, 365;  $s^2 = 1 - z^3$ , the, 368.  
 Function,  $w = z^2$ , the, 82.  
 Function,  $w = z^n$ , the, 87; is automorphic, 88; determines a cyclic group, 90; fundamental region for, 92.  
 Function,  $z = w + i\sqrt{1 - w^2}$ , the, 355.  
 Functions, analytic, of analytic functions, 397.  
 Functions, coincidence of, 208, 384.  
 Functions, hyperbolic, 217, 219-221.  
 Functions, many-valued, 284.  
 Functions, of a real variable, 127.  
 Functions, of  $\sqrt{(z-a)/(z-b)}$  and  $\sqrt{(z-a)(z-b)}$ , 342, 368.  
 Functions, rational, of  $z$  and  $\sigma = \sqrt{(z-a)(z-b)}$ , 344.  
 Fundamental laws, the, 1, 5, 7, 10.  
 Fundamental operations, 22, 23.  
 Fundamental region, definition of, 84.  
 Fundamental region, for  $e^z$ , 225.  
 Fundamental region for  $w = z^n$ , 91.  
 Fundamental theorem of algebra, 229, 232, 240.  
 GAUSS, 9, 12, 43, 308.  
 GAUSS'S series, 214.  
 Generalization of transcendental functions, 216.  
 Generalization of DE MOIVRE'S theorem, 309.  
 Geometrical representation of addition, 16; of complex numbers on the sphere, 51; of subtraction, 18; of multiplication, 18-20.  
 GMEINER, A., and O. STOLZ, 22.  
 GORDAN, 232.  
 GOURSAT, 190.  
 GOURSAT-HEDRICK, 182, 232.

- GREEN'S theorem, 280.
- Group, cyclic, 90; definition of, 57; finite discontinuous, 93, 113; invariant of  $a$ , 72.
- HANKEL, H., 23.
- HARKNESS and MORLEY, 186, 188, 280, 384.
- Harmonic, division of a line segment, 61; points, 72.
- HEINE, 132.
- HEINE-BOREL theorem, 162.
- Helicoidal surface, 290; complex numbers on,  $a$ , 291; pitch of the, 292.
- HERZ, 308.
- Higher derivatives (cf. also successive derivatives), 179.
- HOFFMAN, FR., 329.
- Holomorphic function, 252.
- Hyperbolic functions, 217, 219-221.
- Hyperbolic linear substitution, 94-98.
- Hypergeometric series, 214.
- Images, reflected, 408.
- Imaginary axis, 13; imaginary numbers as number-pairs, 3; imaginary part of complex numbers, 10.
- Improper domain, 141; path, 141.
- Independent of the path, the derivative is, 175, 176, 178; the integral is, 191.
- Indeterminate value of a function, 45, 103, 174, 228.
- Inferior limit, 130.
- Infinite, definitely, 255, 256.
- Infinite series, convergence of, 169, 170; sum of, 169; of partial fractions, 263.
- Infinite value, fundamental laws for, 46; of a complex variable, 45, 47; of a function, 173; on the sphere, 51.
- Infinitesimal, definition of, 182; triangle, 183.
- Infinity, as an inner point, 238; behavior of a function at, 229; circular points at, 70; corresponds to zero, 45, 104;  $v$ -fold of a rational function, 102; point at, 45, 48; regarded as  $1/0$ , 45; two views of, 173; value of a function at, 105, 173.
- Inner point of a set, 137.
- Integers of arithmetic, 1, 2.
- Integral, absolute value of, 155; along a closed curve, 190, 195, 196; analytic continuation of an, 385; classified by discontinuities, 352; curvilinear, 156, 158, 189; definition of a definite, 151; derivative of an, 206; equal to zero, 190, 191, 193, 195.
- Integral function, linear, 32-38.
- Integral function, rational, 29, 98, 231, 233.
- Integral function, transcendental, definition, 201, 392.
- Integral function, transcendental, as a product, 375.
- Integral function, transcendental, at infinity, 233.
- Integral, independent of the path, 191; of a rational function, 351; of a regular function, 188; transformation, linear, 32-38; upper limit of an, 189; upper, lower, 152; with logarithmic discontinuities, 353.
- Integrals, FRESNEL, 215.
- Integrand, 154.
- Integration, arithmetic definition of, 151; between complex limits, 188; CAUCHY'S theorem on, 190, 199; inverse of differentiation, 155, 192; of a series term by term, 155, 200; path of, 189.
- Interval, partition of an, 151; segment, 127.
- Invariant, double ratio is, 65; of a group, 72; (fixed) points, 33, 57, 64.
- Inverse circular and the logarithmic functions, 365.
- Inverse of the logarithm, 305, 306.
- Inverse sine, defn., 360.
- Inverse tangent, defn., 313; poles of the, 315.
- Inverse transformation, the, 57, 114.
- Involutoric transformation, 38, 40, 75.
- Irrational numbers, 2, 127, 128.
- Isogonal representation, 43.
- Isolated point of a set, 137; isolated singular point, 227, 247, 254, 389.
- Isometric, isothermal system of curves, 185.
- JORDAN, 152.

- KIRCHHOFF**, 96.  
**KLEIN**, 94, 119, 413.
- LAGRANGE**, 308.  
**LAPLACE**, 180.  
**LAURENT'S** series, 247-251, 254.  
**LAURENT'S** theorem applied to the surface for  $\sqrt{z}$ , 339.  
**Law**, the associative, 5, 10; the commutative, 5, 7; the distributive, 7.  
**Laws**, the fundamental, 1, 5, 7, 10.  
**Least upper bound**, 128.  
**LENNES, VEULEN** and, 28, 131, 140, 162.  
**Level**, lines of, 187.  
**LIE**, S., 23.  
**Limit** of a convergent sequence, 168; of a complex function, 167, 171; of a function of two real variables, 144; superior, inferior, 130; upper, of an integral, 189; uniform approach to, 132, 141, 155.  
**Limit points**, 127, 128; in the plane, 137.  
**Line** of singularities, 391; is a natural boundary, 391.  
**Linear fractional transformation**, 54.  
**Linear integral function**, transformation, 32-38.  
**Linear substitution**, transformation, 54.  
**Linear transformation** into itself, a, 84; on the sphere, 77.  
**Lines**, as sets of points, 138; niveau, 187; of equipotential, 187; of flow, 187; of level, 187.  
**Logarithm**, amplitude of the, 296; a many-valued function, 297; a regular function, 297; conformal representation by the, 304; definition of the, 294; expansion of the, in a **TAYLOR'S** series, 297, 298; inverse of the, 305, 306; natural, 294; of a real positive, negative number, 297; principal value of the, 295, 297, 304; real, 296, 304; **RIEMANN'S** surface of the, 297.  
**Logarithmic**, derivative, 240, 374; discontinuities of integrals, 353; and inverse circular functions, 365; residue, 354.  
**Lower bound** = upper integral, 152; lower integral, 152; lower limit, 130; lower, upper bounds, 127, 128.
- Loxodrome** or rhumb line, 307.  
**Loxodromic linear substitution**, 94.
- Maclaurin's development** in a power series, 206, 207.  
**Many-fold root**, 99.  
**Many-valued functions**, 284.  
**Many-valuedness** of the amplitude, 21.  
**Map**, of a rational function, 173; of a rectangle upon a circular ring, 257; of surfaces, construction of, reference, 308; of the  $z$ -plane, 29; of a triangle on the half-plane, 403, 409.  
**Mapping**, general continuous, 148, 151, 182; with preservation of angles, 43; with a regular function, 182; with  $w = z^2$ , 83, 85-87; with  $w = z^n$ , 88.  
**MERAY**, Ch., 168.  
**MERCATOR'S** projection, 307.  
**Meridians** on the sphere, 51.  
**Method** of undetermined coefficients, 207.  
**MITTAG-LEFFLER'S** partial fractions, 373; theorem, 262.  
**MÖBIUS**, 54, 72.  
**Modulus**, 14; cartographic, 183; of periodicity, 352.  
**Monogenic function**, 178.  
**Monotonic**, 134; partitively, 140.  
**MORLEY, HARKNESS** and, 186, 188, 280, 384.  
**Motions** in space as a collineation, 80.  
**Multiplication**, geometrical representation of, 18-20; of complex numbers, 10; of number-pairs, 6; of series, 212.
- Natural boundaries**, a line of singularities, 391; and singular points, 389, 393.  
**Natural logarithm**, 294.  
**Negative numbers**, 2.  
**Neighborhood**, circular, rectangular, 137; of a point, 136.  
**NEUMANN'S** sphere, 47, 77.  
**Niveau lines**, 187.  
**Non-collinear**, three points, 24.  
**Non-essential singular point** or pole, 227, 228, 247, 254, 389, 392.  
**Norm**, 14, 19.  
 **$n$ th root** of  $z$ , the, 365.  
 **$n$ -valued function** at a point, 242.  
**Number** of zeros and poles, 240-242.

- Number-pairs, addition and subtraction of, 3-6; as complex numbers, 7; as "imaginary" numbers, 3; division of, 6; equality of, 4; in the form  $(a + bi)$  9; multiplication of, 6, 7; opposite, 5; units for, 7.
- Numbers, a notation for points, 127.
- Numbers, complex, geometrical representation of, 1, 12; multiplication of, 10; units of, 8.
- Numbers, "imaginary," as number-pairs, 3, 7.
- Numbers, irrational, 127, 128.
- Numbers, negative, fractional, irrational, 2.
- Numbers, opposite complex, 15.
- Numbers, real, general arithmetic of, 1, 2; combinations of, 1.
- Odd, even function, 272.
- One-to-one correspondence, 12, 13, 29, 127.
- Opposite complex numbers, 15.
- Order of a rational function, 102, 103; sum of all, 106, 242.
- Order at a pole, at a zero, 103.
- "Origin" of coördinates, the, 12.
- Orthomorphic transformation, 43.
- OSGOOD, 25, 142, 186, 232, 384.
- PAINLEVE, P., 400.
- Parabolic linear substitution, 94-97.
- Parallel displacement, 30.
- Parallel translation in the plane, 28, 30.
- Parametric representation of a curve, 139.
- Partial derivative, 150.
- Partial differential equations, 280.
- Partial fractions, decomposition into, 268.
- Partial fractions, infinite series of, 263.
- Partial fractions, MITTAG-LEFFLER'S, 373.
- Partition, DEDEKIND, 128.
- Partition of an integral, 151.
- Partitively monotonic, 140.
- "Parts" of the RIEMANN'S surface, 323.
- Path, 140; improper, 141.
- Path-curves, 187.
- Path of integration, 189.
- Perfect set of points, 138.
- Period of trigonometric and exponential functions, 222, 223.
- Period, primitive, 222; strip, 224-226.
- Periodic function, 84, 222, 282; singly, 224, 268, 273; values of, 233.
- "Periodicity, modulus of," 352; of the trig. and exp. functions, 222.
- Permanently convergent power series, 201.
- PICARD, 235, 267, 278.
- PIERPONT, 3, 128.
- Pitch of the helicoid, 292.
- Plane RIEMANN'S surface, 292.
- POINCARÉ, 98.
- Point, at infinity, 45, 48; boundary, 137; inner, of a set, 137; isolated, 137; limit, 127, 128.
- Points, aggregate, assemblage, class, collection of, 127; diametral, 53, 80; equianharmonic, harmonic, 72; of the plane, 12; sets of, on a straight line, 127; sets of, in the plane, 135.
- Polar coördinates, 13.
- Pole, at a branch-point, 335; at infinity, 105; continuity at a, 172; many-fold, 102; or nonessential singular point, 227, 247, 254, 389, 392; residue at a, 237.
- Poles and zeros, 242, 243; number of, 240-242; of the inverse of  $\tan^{-1} z$ , 315.
- Positive half-plane, 67.
- Potential, electrical, 187; velocity, 186, 187.
- Power series, 168; absolute convergence of, 202; a continuous function, 203; a regular function, 203; coefficients of a, 206-210; coincidence of, 207; convergence of, 201; circle of convergence of, 202; derivative of, 149, 203; development in, 199, 207; permanently convergent, 201; properties of, 201; successive derivatives of, 204; TAYLOR'S, MACLAURIN'S, 206; uniform convergence of, 202, 203.
- Primitive period, 222.
- Principle of reflection, the, 399.
- Principal value of the amplitude, 284; of the logarithm, 295, 297, 304; of the square root, 319.
- PRINGSHEIM, 165.

- Product, absolute value of, 19; amplitude of, 19; form for the sine, 376; form for a transcendental integral function, 375; of two complex numbers, unique, 10; of two series, convergence of, 212; WEIERSTRASSIAN, 373; when zero, 11.
- Progressive, regressive derivatives, 163, 165.
- Projection, MERCATOR'S, 307; stereographic, 47, 53, 307; angles preserved in stereographic, 48.
- Pure imaginary numbers, 10.
- Quadruple numbers, 22.
- Quantity, complex (a complex number), 9.
- Quotient, 20; of two conjugate complex numbers, 21.
- Radius vector, 13.
- Rational function, behavior of  $a$ , at infinity, 104; continuity of  $a$ , 133, 170, 172; definition of  $a$ , 28, 29, 167, 231, 392; degree of, 102; derivative of  $a$ , 174; indeterminate, 45, 103; many-fold pole of  $a$ , 102; many-fold zero of  $a$ , 102; map of  $a$ , 173; order of  $a$ , 102, 103; pole of  $a$ , 242; reciprocal of  $a$ , 172, 173, 228; sum of all the orders of  $a$ , 106, 242; value of  $a$ , at infinity, 105; when infinity is a pole, a zero of  $a$ , 105, 106; zero of  $a$ , 242.
- Rational functions of  $z$  and  $s = \sqrt{z}$ , 331; of  $z$  and  $\sigma = \sqrt{(z-a)(z-b)}$ , 344.
- Rational integral function, 29, 98, 231, 233, 292, 392; has  $n$ -fold pole at  $\infty$ , 242, 392; has  $n$  zeros, 242.
- "Rationalizing," 345.
- Real axis, 13.
- Real logarithm, 296.
- Real numbers, combinations of, 1; general arithmetic of, 1, 2.
- Real part of complex numbers, 10.
- Real variable, functions of  $a$ , 127.
- Reciprocal of a complex number, 21.
- Reciprocal of a rational function, 172, 173, 228.
- Reciprocal radii, transformation by, 38, 41; on the sphere, 51.
- Rectangular contour, 158.
- Reflected images, 408.
- Reflection on axis of reals, 39; on a circle, 407; on equatorial plane, 52; on a straight line, 402; on unit circle, 40; principle of, 399.
- Regressive, progressive derivatives, 163, 165.
- "Regular at," "analytic about," 282.
- Regular function, definition, 178; expanded in a power series, 199; mapping with  $a$ , 182; near a singular point, 227, 247, 254; on the RIEMANN'S surface, 334; successive derivatives of, 204; value in a domain, 196.
- Regular functions, sums of, 260.
- Removable discontinuities, 103, 228, 252.
- Representation, conformal, 28, 41, 43, 182, 184.
- Representation, geometrical, of addition and subtraction, 16; of complex numbers, 1, 12; of double algebra, 3; of multiplication, 18-20.
- Representation, isogonal, 43; of  $z$ -plane, 29; parametric, 139; similar in infinitesimal parts, 43.
- Residue at a logarithmic discontinuity, 354; at a pole, 237, 241.
- Residues, 237-239; CAUCHY'S theorem on, 236.
- Rhumb line or loxodrome, 307.
- RIEMANN, 29, 47, 168, 178, 179, 214.
- RIEMANN'S surface, general construction of the, 385; of the amplitude, 289; of the logarithm, 297; of the square root, 319; plane, 292, 293; "sheets" of the, 293.
- Root of a number-pair, square, 9.
- Roots, limits of the, 100, 101; many-fold, 99; of unity, 25, 72.
- Rotating and stretching, 32, 33.
- Rotating the plane into itself, 31.
- Scale of similarity, 183.
- SCHWARZ, H. A., 402, 407, 420.
- Screw surface, 290.
- Segment, 127; closed, connected, 138.
- Sequence, convergent, 129; increasing, 130; limit of convergent, 168.

- Series, absolute convergence of, 170; convergence of, 169, 170, 201; convergence of a product of two, 212; FOURIER'S, 257; GAUSS'S, 214; hypergeometric, 214; of partial fractions, infinite, 263; LAURENT'S, 247-251, 254; power (cf. power series); sum of an infinite, 169.
- Set of points, closed, connected, perfect, 138; as lines, surfaces, 138.
- Sets of points, dense, 138; derived, 131; inner point of a, 137; on a straight line, 127.
- "Sheets" of a RIEMANN'S surface, 293, 323.
- Similar figures transformed into each other, 36.
- Similar triangles, condition for, 36.
- Similarity, scale of, 183; transformation, 32, 35.
- Simple curve, 140.
- Simply connected domain, 142.
- Sine, 216-221; is a symmetric automorphic function, 226; inverse, 360; period of, 222; product for the, 376.
- Single-valued analytic functions, 167.
- Single-valued function on the RIEMANN'S surface, 333.
- Singly periodic function, 224; conformal representation by, 224; general theorems on, 273; partial fractions of, 268.
- Singularities, branch-points are, when, 393, 395; line of, 391; line of, as a natural boundary, 391; and natural boundaries, 389, 393; removable, 103, 228, 252.
- Singular point, essential, 389, 390, 392; isolated, 227, 247; 254, 389; non-essential or pole, 227, 228, 389, 392; regular function near a, 227, 247, 254.
- $\text{Sin}^{-1} w$ , 360.
- Situs, analysis, 328.
- Sphere, 47; NEUMANN'S, 47, 77.
- Square root, 316-319; branch-points of, 322; definition, 317; connectivity of its surface, 328; deformation of its surface, 329; expansion in a power series, 337; of a number-pair, 9; principal value of, 319; RIEMANN'S surface of, 319; a single-valued function of position, 322.
- Squares, indefinitely small, 185, 187.
- Stereographic projection, 47, 53, 307.
- Stretching and rotating, 32, 33.
- Stretching the plane into itself, 31.
- STOLZ, O., and A. GMEINER, 22.
- Strip, period, 224-226.
- Subgroup, 57.
- Substitution, linear (= bilinear), 54; elliptic, hyperbolic, loxodromic, parabolic, 94-98.
- Subtraction, geometrical representation of, 18.
- Successive derivatives of a power series, of a regular function, 204.
- Sum, absolute value of a, 17.
- Sum of an absolutely convergent series, 170; of an infinite series, 169; of regular functions, 260.
- Superior limit, 130.
- Surface, 136; as a set of points, 138; general definition of, 139, 140; helicoid, screw, 290; plane, RIEMANN'S, 292, 293; RIEMANN'S (cf. RIEMANN'S surface).
- $\text{Tan}^{-1} z$ , definition, 313; mapping with, 314; poles of the inverse of, 315; principal value of, 313.
- TAYLOR'S series, 206, 209, 213, 383; for the logarithm, 297, 298.
- Term by term differentiation, 149, 156.
- Term by term integration, 155, 200.
- Theorem, addition, for trigonometric and exponential functions, 218; binomial, 221; DE MOIVRE'S, a generalization of, 309; fundamental, of algebra, 229, 232, 240; GREEN'S, 280; LAURENT'S, 247, 254; LIOUVILLE'S, 230; MITTAG-LEFFLER'S, 262; on integration, CAUCHY'S, 190, 195, 199, 247; on residues, CAUCHY'S, 236.
- Theorems, general, on singly periodic functions, 273.
- THOMAE, 152, 168.
- THOMSON images, 40.
- Topology, 328.
- Total variation of a quantity, 175.
- Transcendental functions, 124, 167, 282, 392; generalization of, 216.

- Transcendental integral function, definition, 201; as a product, 375; at infinity, 233, 255.  
 Transformation, bilinear, 54.  
 Transformation, by rotating the sphere, 52.  
 Transformation, circle, 54, 56.  
 Transformation, degenerate, 55.  
 Transformation, determinant of the, 55.  
 Transformation, "direct" similarity, 35.  
 Transformation, identical, 57.  
 Transformation, into itself, linear, 84.  
 Transformation, inverse, 57, 114.  
 Transformation, involutoric, 38, 40, 75.  
 Transformation, linear (cf. substitution, linear).  
 Transformation, linear fractional, 54.  
 Transformation, linear integral, 32-38.  
 Transformation of the sphere into itself, 51.  
 Transformation of the plane, 29; by reciprocal radii, 38; by rotation, 31; by stretching, 31; by a translation, 30.  
 Transformation on the sphere, linear, 77.  
 Transformation, orthomorphic, 43.  
 Transformation, periodic, 93, 95.  
 Transformation, reciprocal radii, 38, 41; on the sphere, 51.  
 Transformation, similarity, 32, 35.  
 Transformations, group of, 90, 113.  
 Translation, parallel, 28, 30, 33.  
 Transmission of electricity, 187; of heat, 187.  
 Triangles, infinitesimal, 183; similar, 136.  
 Trigonometric functions, 216-221; addition theorem for, 218; periodicity of, 222.  
 Triple numbers, 22.  
 Unconditional convergence, 170.  
 Undetermined coefficients, method of, 207.  
 Uniform approach to a limit, 132, 141, 155.  
 Uniform convergence, 155, 156, 200, 202, 203.  
 Uniform continuity, 132.  
 "Uniformizing" variable, 276.  
 Unique development in a power series, 207.  
 Unit circle, 15, 40; mapped on  $z$ -half-plane, 67; reflection on, 40.  
 Units for complex numbers, 8; for number-pairs, 7.  
 Upper, lower bounds, 127, 128.  
 Upper bound = low integral, 152.  
 Upper bound, least, 128.  
 Upper integral, 152.  
 Upper limit of an integral, 189.  
 Value of a function, at  $\infty$  and  $=\infty$ , 173; in a domain, 106; indeterminate, 45, 103, 174.  
 Values of a periodic function, 233.  
 Variable, definition of complex, 28; uniformizing, 276.  
 Variation of a quantity, total, 175.  
 WEBER and LENNES, 28, 131, 140, 162.  
 Velocity potential, 186, 187.  
 WEBER, 317.  
 WEIERSTRASS, 129, 168, 201, 228, 261, 263, 382, 383; expansion in a product, 373.  
 WHITTAKER, 276.  
 Winding-point, 395.  
 YOUNG, W. H. and G. C., 136.  
 Zero, 205, 211, 241; at  $\infty$ , 106; corresponds to  $\infty$ , 45, 104; division by, 45; many-fold, 102; point, 102.  
 Zeros and poles, 242; at a branch-point, 335; number of, 240-242.







