

UNIVERSAL
LIBRARY

OU_168074

UNIVERSAL
LIBRARY

OSMANIA UNIVERSITY LIBRARY

Call No. 668.5

Acc. No. 29676

693E

Genethex Ernest -

The Essential will.

OSMANIA UNIVERSITY LIBRARY

Call No. 668.5/693 E Accession No. 29676

Author Quenther, E. v. 2

Title Essential oils

This book should be returned on or before the date
last marked below.

The Essential Oils

BY

ERNEST GUENTHER, PH.D.

*Vice President and Technical Director
Fritzsche Brothers, Inc., New York, N. Y.*

VOLUME TWO
THE CONSTITUENTS OF
ESSENTIAL OILS

Co-author

DARRELL ALTHAUSEN, PH.D.

*Manager, Clifton Factory
Fritzsche Brothers, Inc., Clifton, N. J.*

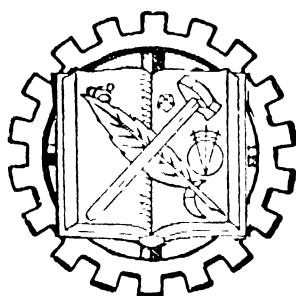

1949

D. VAN NOSTRAND COMPANY, INC.

TORONTO

NEW YORK

LONDON

NEW YORK

D. Van Nostrand Company, Inc., 250 Fourth Avenue, New York 3

TORONTO

D. Van Nostrand Company (Canada), Ltd., 228 Bloor Street, Toronto

LONDON

Macmillan & Company, Ltd., St. Martin's Street, London, W.C. 2

COPYRIGHT, 1949, BY

D. VAN NOSTRAND COMPANY, INC.

Published simultaneously in Canada by

D. VAN NOSTRAND COMPANY (Canada), LTD.

All Rights Reserved

This book, or any parts thereof, may not be reproduced in any form without written permission from the authors and the publishers.

PRINTED IN THE UNITED STATES OF AMERICA

Dedicated

to MR. FREDERICK H. LEONHARDT,
President of
Fritzsche Brothers, Inc.,
whose vision and generosity made this
work possible

AUTHORS OF CHAPTERS

ERNEST GUENTHER, Ph.D.

Vice President and Technical Director of Fritzsche Brothers, Inc., New York, N. Y.

DARRELL ALTHAUSEN, Ph.D.

Manager, Fritzsche Brothers, Inc., Clifton Factory, Clifton, N. J.

FRANCES S. STERRETT, Ph.D.

Research Chemist, Fritzsche Brothers, Inc., New York, N. Y.

PREFACE

In the course of the last century, hundreds of organic compounds have been identified among the natural compounds of essential oils. Some of these compounds are extremely rare, having been found in only one oil; others are common, and have been observed in a number of oils.

The task of the scientist in the field, whether he be a research worker or a laboratory analyst, has naturally increased in difficulty as the number of such compounds has mounted and information about them has swelled the literature on the subject. More and more of the chemist's time must now be spent on preliminary searches of such literature before he can undertake his own creative work.

The present volume, the second in a series on THE ESSENTIAL OILS, represents an attempt to eliminate at least some of the tedious "spade-work" necessarily performed by the essential oil chemist. To this end, data on several hundred of the most important natural constituents of essential oils have been assembled into one volume, in the form of monographs, and brought as nearly up-to-date as possible. The structural formulas, occurrence, methods of isolation and identification, and physico-chemical properties of these compounds have been described. Succeeding volumes of this series will deal with individual essential oils and their chemical composition, and frequent reference will be made to the monographs contained in this volume.

A secondary aim of the present work is to stimulate further research in the field, particularly on essential oils of which the chemical composition is, so far, either only partially elucidated or entirely unknown.

The task of writing this book has been a complicated one, requiring years of work—a result, among other things, of the confusion existing in older literature, particularly in regard to stereoisomeric compounds. The difficulties of compiling material for the volume were further increased by the fact that during the Second World War scientific literature from continental Europe, the U.S.S.R., Japan and other parts of the world was not available. Even today much of it is accessible only in abstract form—through "Chemical Abstracts," for example.

For some of the older data presented in this work, the authors are indebted to Gildemeister and Hoffmann's classical work, "Die Ätherischen Öle," Third Edition, as a point of departure. Even where this is so, however, original references quoted in their work have been verified, and the material has been carried up-to-date.

Chemical research in scientific and industrial laboratories goes on without interruption, so that there is, unfortunately, no particular moment at which an author may lay down his manuscript with a happy sense of having covered every important aspect of his field right up to that moment. The printing of such a work as the present one has alone required more than a year, during which time new discoveries have been made, some of them of fundamental importance. The authors have endeavored, where it was possible, to incorporate such new material into their work. Some deadline had finally to be set, however!

ERNEST GUENTHER
DARRELL ALTHAUSEN

September, 1948
New York, N. Y.

ACKNOWLEDGMENT

The authors of the present volume are deeply grateful to a number of co-workers on the staff of Fritzsche Brothers, Inc., New York, N. Y., and to several friends and prominent experts in the essential oil field—abroad as well as in the United States—who willingly and diligently helped them in the difficult task of preparing this work. May the authors, therefore, express their profound gratitude to:

Dr. Frances S. Sterrett, Research Chemist of Fritzsche Brothers, Inc., New York, N. Y., for her chapter, "The Preparation of Derivatives of Essential Oil Constituents."

Mr. Edward E. Langenau, Director of Analytical Laboratories, Fritzsche Brothers, Inc., New York, N. Y., for his numerous suggestions on many points in the text.

Mr. W. P. Leidy, Chief Librarian, and Mr. Anthony Hansen, Jr., Librarian of Fritzsche Brothers, Inc., New York, N. Y., for their thorough bibliographic work.

Mrs. Ann Blake Hencken, Miss Catherine McGuire, and Mrs. Agnes Clancy Melody, Secretarial Staff of the authors in New York, for their intense interest in, and most diligent execution of, their tedious task.

Without the untiring efforts of all these co-workers and friends this work could not have been accomplished.

The authors are indebted, further, to Dr. A. J. Haagen-Smit, Professor, Bio-organic Chemistry, California Institute of Technology, Pasadena, California; Dr. T. F. West, Research Laboratories of Drug Houses of Australia, Ltd., Melbourne; Dr. Yves-René Naves, Research Laboratories of Givaudan & Cie, Geneva, Switzerland; and Dr. H. Schinz, Research Laboratories of Firmenich et Cie., Successeurs de Chuit, Naef et Cie., Geneva, Switzerland, who offered valuable suggestions and contributions to several monographs on newly discovered essential oil compounds.

Sincere thanks are also due to the staff of the New York Public Library, and of the Libraries of the Bronx Botanical Garden and the Chemists' Club, New York, N. Y.

ERNEST GUENTHER
DARRELL ALTHAUSEN

NOTE

All temperatures given in this work are expressed in degrees Centigrade unless otherwise specified in the text.

CONTENTS

THE CONSTITUENTS OF ESSENTIAL OILS

	PAGE
INTRODUCTION	1
I. HYDROCARBONS	
A. ALIPHATIC HYDROCARBONS	7
(a) Paraffins	7
(b) Olefins	7
(c) Olefinic Terpenes	7
B. AROMATIC HYDROCARBONS	12
C. CYCLIC TERPENES	18
(a) Monocyclic Terpenes	18
(b) Bicyclic Terpenes	49
(c) Series of Lower Terpene Homologues	79
D. SESQUITERPENES	81
(a) Aliphatic Sesquiterpenes	83
(b) Monocyclic Sesquiterpenes	84
(c) Bicyclic Sesquiterpenes	91
(d) Tricyclic Sesquiterpenes	112
E. DITERPENES	125
F. AZULENES	127
II. ALCOHOLS	
A. ALIPHATIC ALCOHOLS	141
(a) Saturated Aliphatic Alcohols	141
(b) Unsaturated Aliphatic Alcohols	158
(c) Aliphatic Terpene Alcohols	166
B. CYCLIC TERPENE ALCOHOLS	184
(a) Monocyclic Terpene Alcohols	184
(b) Bicyclic Terpene Alcohols	229
(c) Tricyclic Terpene Alcohols	257
C. SESQUITERPENE ALCOHOLS	258
(a) Aliphatic Sesquiterpene Alcohols	258
(b) Monocyclic Sesquiterpene Alcohols	261
(c) Bicyclic Sesquiterpene Alcohols	263

	PAGE
(d) Tricyclic Sesquiterpene Alcohols.....	280
(e) Sesquiterpene Alcohols of Doubtful Constitution.....	281
D. AROMATIC ALCOHOLS.....	290
E. MISCELLANEOUS ALCOHOLS.....	299
 III. ALDEHYDES	
A. ALIPHATIC ALDEHYDES.....	305
(a) Saturated Aliphatic Aldehydes.....	307
(b) Unsaturated Aliphatic Aldehydes.....	318
(c) Aliphatic Terpene Aldehydes.....	326
B. CYCLIC TERPENE ALDEHYDES.....	342
C. AROMATIC ALDEHYDES.....	350
D. HETEROCYCLIC ALDEHYDES.....	367
 IV. KETONES	
A. ALIPHATIC KETONES.....	373
(a) Saturated Aliphatic Ketones.....	373
(b) Unsaturated Aliphatic Ketones.....	381
B. CYCLIC TERPENE KETONES.....	388
(a) Monocyclic Terpene Ketones.....	388
(b) Bicyclic Terpene Ketones.....	418
C. SESQUITERPENE KETONES.....	448
D. THE IONONES.....	458
E. THE IRONES.....	466
F. AROMATIC KETONES.....	474
G. MISCELLANEOUS KETONES.....	480
H. LARGE RING KETONES.....	489
I. KETONES OF DOUBTFUL CONSTITUTION.....	494
 V. PHENOLS AND PHENOL ETHERS.....	
499	
 VI. QUINONES.....	
549	
 VII. ACIDS	
A. ALIPHATIC ACIDS.....	560
(a) Saturated Aliphatic Acids.....	560
(b) Unsaturated Aliphatic Acids.....	583
(c) Dibasic Aliphatic Acids.....	592
(d) Aliphatic Hydroxy Acids.....	593
B. AROMATIC ACIDS.....	596
C. MISCELLANEOUS ACIDS.....	606
D. ACIDS OF DOUBTFUL CONSTITUTION.....	612
E. ANHYDRIDES.....	613

	PAGE
VIII. ESTERS	
A. ALIPHATIC ESTERS	618
B. TERPENE ESTERS	620
C. AROMATIC ESTERS	635
D. ESTERS CONTAINING NITROGEN	651
IX. LACTONES, COUMARINS, AND COUMARONES	659
X. FURAN DERIVATIVES	699
XI. OXIDES	707
XII. COMPOUNDS CONTAINING NITROGEN AND SULFUR	
A. CYANIDES	721
B. AMINO AND IMINO COMPOUNDS	725
C. SULFIDES	729
D. MUSTARD OILS	734
 <i>TERPENES, SESQUITERPENES, AND DERIVATIVES OF UNKNOWN CONSTITUTION</i> 	
I. HYDROCARBONS	
A. TERPENES	745
B. SESQUITERPENES	747
(a) Bicyclic	747
(b) Tricyclic	749
(c) Unknown	750
C. AROMATIC HYDROCARBONS	753
II. ALCOHOLS	
A. TERPENE ALCOHOLS	754
B. SESQUITERPENE ALCOHOLS	755
(a) Monocyclic	755
(b) Bicyclic	755
(c) Tricyclic	759
(d) Unknown	760
III. KETONES	765
IV. PHENOLS	766
V. LACTONES	767
VI. MISCELLANEOUS COMPOUNDS	768

**THE PREPARATION OF DERIVATIVES OF ESSENTIAL
OIL CONSTITUENTS**

by Frances S. Sterrett, Ph.D.

	PAGE
INTRODUCTION	771
I. HYDROCARBONS	774
A. OXIDATION	774
1. Dehydrogenation	776
B. ADDITION PRODUCTS	776
1. Addition of Water (Hydration)	776
2. Addition of Hydrogen (Hydrogenation)	777
3. Addition of Hydrogen Halide	778
4. Addition of Halogen (Halogenation)	780
5. Addition of Nitrogen-containing Compounds	781
6. Addition of Maleic Anhydride	786
7. Addition of Sulfuric Acid (Sulfonation)	787
8. Addition of Picric Acid and Related Substances	788
II. ALCOHOLS	791
1. Dehydration Products	791
2. Calcium Chloride Addition Products	792
3. Esters	792
4. Urethanes	798
5. Xanthates (Xanthogenates)	802
III. ALDEHYDES AND KETONES	804
A. REACTIONS AND REACTION PRODUCTS OF HELP IN THE DIFFERENTIATION OF ALDEHYDES FROM KETONES, AS WELL AS IN THE IDENTIFICATION OF ALDEHYDES	805
1. Oxidation	805
2. Condensation	805
B. REACTIONS AND REACTION PRODUCTS OF HELP IN THE IDENTIFICATION OF ALDEHYDES AND KETONES	808
1. Reactions Typical Only of Aldehydes and Certain Ketones (Methyl Ketones and Ketomethylene Compounds)	808
2. Reactions Characteristic of Both Aldehydes and Ketones	809
(a) Reactions with Hydroxylamine (Oximation)	809
(b) Reactions with Hydrazine Compounds	810
(c) Reactions with Sodium (or Potassium) Cyanide and Ammonium Carbonate (to Form Hydantoin Derivatives)	820

CONTENTS

xiii

PAGE

IV. PHENOLS AND PHENOL ETHERS.....	823
V. ACIDS.....	827
VI. ESTERS.....	831
VII. LACTONES AND ANHYDRIDES.....	833
VIII. OTHER CONSTITUENTS.....	833
INDEX.....	835

INTRODUCTION

The treatises on essential oils published by Semmler in 1907, Wallach in 1914, Parry in 1919, Simonsen in 1931,* and Gildemeister and Hoffmann in the years 1928–1931, for a long time composed an invaluable source of information on the constituents of these oils, and on numerous synthetic aromatic compounds.

The chemical literature of the last two decades has added much material to that mentioned above, however, and has enriched our knowledge of the structural formulas and properties of essential oil constituents, with the result that a more up-to-date presentation—such as that undertaken in this work—is indicated.

It has been the authors' aim to be as comprehensive as possible; to present both old and new data where they appear to be reliable and important. Some editing has been necessary, of course, for chemical literature abounds with references to compounds which are either of obvious impurity or derived from oils of dubious botanical origin. Where such has been the case, the authors have preferred to do no more than briefly describe the compound, with indicative reference to the original literature in which it is more fully discussed.

In this volume, special emphasis has been laid upon the natural constituents of essential oils. Nevertheless, a limited number of synthetic products structurally related to certain natural isolates, and of interest to the essential oil chemist, have been added.

In the main, the nomenclature followed here is that employed in "Chemical Abstracts." In certain instances, however, well-established common names have been preferred for compounds, since they may serve to identify such compounds more easily both in the trade and in the literature.

The following abbreviations have been used (the reader should bear in mind that temperatures given are in degrees centigrade, unless otherwise specified):

- m. Melting point.
- cong.pt. Congealing point.
- f.p. Freezing point.
- b. Boiling point at atmospheric pressure (about 760 mm.); for example: b. 150° would mean that a liquid boils at 150° C., at atmospheric pressure.

* A new edition of volume I of this work was published in 1947.

- b_x Boiling point at "x" mm. pressure; for example: $b_{10} 100^\circ$ would mean that a liquid boils at 100° C. if the pressure is reduced to 10 mm. Hg.
- d Specific gravity, without indication of temperature. Wherever possible, the temperature of measurement is recorded as given in the original literature. For example: d_4^{15} would mean a specific gravity determined at 15° C. and referred to water at 4° C.
In most cases the older literature omits the temperature of the water; for instance, d_{15} would mean that the specific gravity of the compound was determined at 15° C., without indicating the temperature of the water. Often this is written as d^{15} .
- α_D Optical rotation of a compound in a 10-cm. tube and in sodium light. α_D^{20} would mean that the measurement was made at a temperature of 20° C. In most cases (except for certain citrus oils) the temperature does not exercise a marked influence upon the optical rotation of an essential oil.*
- $[\alpha]_D$ Specific optical rotation.* In many instances the literature—and especially the older literature—does not distinguish clearly between optical rotation and specific optical rotation. Where no clear distinction has been made, the authors have copied the symbol as originally reported.
- n_D Refractive index as determined for the D-line of the sodium spectrum. n_D^{20} would include a temperature of 20° C. at which the determination was carried out in this example.*

With a view to aiding the research worker by presenting him with the most reliable old and recent data on essential oil constituents, the authors have adopted the following scheme of arrangement:

- (a) Occurrence
- (b) Isolation
- (c) Identification
- (d) Properties
- (e) Use.

Wherever it has been established, or postulated upon good authority, the structural formula for a compound is included. This may be followed by a brief introduction, before the section on "Occurrence." In most cases, the authors have not listed all the oils in which a constituent is known to occur, as such listing would have carried the monographs to inordinate length. Only the most important sources are cited, in certain cases including very recently discovered ones. It should be remembered that these compounds will be further discussed in succeeding volumes, in the monographs on individual oils.

* For further information see Vol. I, Chapter 4, "The Examination and Analysis of Essential Oils, Synthetics, and Isolates."

Detailed procedures on "isolation" are included where the data lend themselves to the separation of a pure isomer or where special precautions must be exercised due to sensitivity of the compound.

Whereas the older works in the field did not pay too much attention to identifying a particular stereo form by characteristic derivatives, a definite attempt has been made in the following text to describe these isomers in their purest form.

In respect to the derivatives of compounds enumerated in this work: for purposes of identification, derivatives of high-melting point are in general preferable to those of low-melting point. Wherever possible, derivatives distinct for each form, and special methods of characterizing stereoisomers are included. In some cases a state of dynamic equilibrium may exist between stereo forms in the fraction isolated, or the fraction may consist merely of a mixture of isomers.

Color tests have, in the main, proved unreliable; they have, therefore, been largely excluded from this text.

Not much emphasis is placed in this work upon spectro-photometric data as they are still too meager to be of much practical use. However, the reader will find numerous literature references to publications in this field, which deal with the elucidation of structure.

Wherever possible, data and references have been checked against the original literature. This has resulted in the correction of many errors carried in previous works.

Quantitative methods of assaying the more important constituents of essential oils are given in Vol. I, Chapter 4, "The Examination and Analysis of Essential Oils, Synthetics, and Isolates."

I. HYDROCARBONS

A. ALIPHATIC HYDROCARBONS

(a) **Paraffins.**—The lowest member of the paraffin group C_nH_{2n+2} identified so far in essential oils, according to Gildemeister and Hoffmann,¹ is *n-heptane* C_7H_{16} , b. 98.5° – 99° , d_{15} 0.6880, which has been found in a few pine needle oils.*

The higher members of the paraffin and probably also of the olefin series occur quite frequently in plants, usually in the form of wax-like secretions or coatings of leaves, flowers, and seeds. Because of their low solubility, and low volatility, these waxes are rare in essential oils as obtained by steam distillation. In the case of some oils, the wax content, usually a mixture of homologues, is so high that the oil congeals at room temperature as, for example, in the case of rose and chamomile oils. Waxes occur also in the evaporation residues of expressed citrus oils and, in large percentages, in the concrete natural flower oils, as obtained by extracting flowers with volatile solvents such as petroleum ether or benzene.

When purified, these waxes consist of odorless, white, often laminated, crystalline masses, almost insoluble in cold alcohol but readily soluble in hot alcohol and other organic solvents. They are highly resistant to concentrated acids and oxidizing agents.

(b) **Olefins.**—The only olefinic hydrocarbon, C_nH_{2n} , so far found in volatile oils (in lemon oil and in bergamot oil), according to Gildemeister and Hoffmann,² is *octylene*, b. 123° – 124° , d 0.7275, n_D 1.4060. Octylene probably occurs also in linaloe oil.

The hemiterpene *isoprene* C_5H_8 , genetically related to the terpenes, has been observed as a decomposition product of natural rubber and turpentine oil. According to several authorities, the terpenes, sesqui-, di-, and triterpenes, also natural rubber, originate in plant metabolism by a joining of isoprene molecules.

(c) **Olefinic Terpenes.**—Open-chain hydrocarbons of the general formula C_nH_{2n-4} , and containing three ethylenic linkages, occur in some essential oils. Although complying with the empirical molecular formulas of alicyclic (hydroaromatic) hydrocarbons as cyclic terpenes, these open-chain olefinic terpenes may be distinguished from the former by their lower specific gravity and refractive index. The olefinic terpenes, as they were named by Semmler, are very prone to resinify, especially on distillation at atmospheric pressure.

¹ "Die Ätherischen Öle," 3d Ed., Vol. I, 301.

² *Ibid.*

* Haagen-Smit, Redemann and Mirov [*J. Am. Chem. Soc.* **69** (1947), 2014] recently identified heptane, nonane and *n*-undecane in the gum turpentine from Torrey pine.

SUGGESTED ADDITIONAL LITERATURE

Arthur I. Vogel, "Physical Properties and Chemical Constitution. Aliphatic Hydrocarbons," *J. Chem. Soc.* (1946), 133. *Chem. Abstracts* **40** (1946), 3390.

β-Myrcene

C₁₀H₁₆

Mol. Weight 136.23

2-Methyl-6-methylene-2,7-octadiene

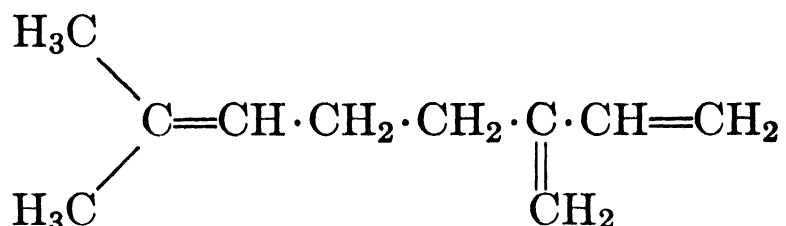

Myrcene possesses the same carbon skeleton as linaloöl. The structural formula of β-myrcene was definitely established by Ruzicka and Stoll,¹ and by Dupont and Desreux.²

Occurrence.—Power and Kleber³ found substantial quantities of myrcene in bay oil (*Myrcia acris* D.C.); myrcene occurs also in oil of hops,⁴ verbena oil (*Lippia citriodora*),⁵ galbanum oil, Formosan and West Indian lemongrass oil, etc.

Isolation.—According to Power and Kleber,⁶ bay oil is treated with sodium hydroxide solution and the remaining undissolved portion repeatedly fractionated *in vacuo*.

Identification.—(1) Reduction with sodium and alcohol yields dihydromyrcene C₁₀H₁₈ which is identical with linaloölene, only two hydrogen atoms thus being taken up. According to Semmler⁷ and Enklaar,⁸ dihydromyrcene on bromination gives tetrabromodihydromyrcene m. 88°. For the hydrogenation of β-myrcene with hydrogen and platinum as catalyst to tetrahydromyrcene, see Dupont and Desreux.⁹

(2) By heating to 250°–260° in a sealed tube, myrcene is converted into a diterpene C₂₀H₃₂, viz., α-camphorene, which occurs also in blue camphor oil. α-Camphorene tetrahydrochloride melts at 129°–130°, according to Semmler and Jonas.¹⁰

For this purpose, myrcene is heated for 4 hr. and the content of the sealed tube fractionated *in vacuo*. The fraction b₈ 175°–195° is dissolved in absolute ether and saturated with dry hydrogen chloride at low temperature. The separating crystals of α-camphorene tetrahydrochloride after several hours are filtered off under suction, washed with cold alcohol, rubbed on a clay plate and recrystallized from absolute alcohol.

(3) Myrcene forms an addition compound with α-naphthoquinone, m. 80°–81.5°, according to Arbusov and Abramov.¹¹

(4) Diels and Alder,¹² Ruzicka¹³ and Lindsay, Briggs and Sutherland¹⁴ prepared the adduct of myrcene and maleic anhydride and described the melting points of several derivatives of this addition compound:

Adduct	34°–35° ^{12, 13}
Dicarboxylic acid	122°–123° ^{12, 13, 14}
Dicarboxylic acid anhydride	206°–207° ¹² and 215° ¹³

(5) Sulfone di- and tetrabromides have been prepared by Backer, Strating and Kool;¹⁵ the sulfone dibromide (C₁₀H₁₆Br₂O₂S) m. 105°, the tetrabromide m. 131°.

Properties.—Due to the ease of polymerization of this unsaturated hydrocarbon, variations in the physicochemical data recorded to date are not to be considered too seriously. The most definitive constants seem to be those reported by Palkin and Wells,¹⁶ and Dupont and Desreux¹⁷ as listed here. However, myrcene has also been characterized by Semmler and Mayer,¹⁸ Lebedev,¹⁹ Chapman,²⁰ Enklaar,²¹ Eijkman,²² Schimmel & Co.,²³ and Petrov and Chel'tsova.²⁴

b.	166°–167° ¹⁶	d_4^{20}	0.791 ¹⁷
b ₂₅	72°–73° ¹⁷	$d_4^{15.5}$	0.7966 ¹⁶
b ₂₀	65°–66° ¹⁶	n_D^{21}	1.470 ¹⁷
		n_D^{20}	1.4650 ¹⁶

Myrcene, in general, is considerably more stable than its isomer ocimene. On standing myrcene undergoes polymerization both to a dimyrcene C₂₀H₃₂ and also to a polymyrcene (C₁₀H₁₆)_x. According to Harries,²⁵ both these polymerides form nitrosites, the latter melting at 163°.

When treated with aqueous potassium permanganate, myrcene is oxidized to succinic acid, according to Power and Kleber.²⁶

Polymerization of myrcene causes a lowering of its solubility in alcohol; this is the chief reason that, on aging, West Indian lemongrass oils lose their originally good solubility in alcohol. East Indian lemongrass oils contain no myrcene and retain their solubility better.

Delaby and Dupin²⁷ oxidized myrcene with selenium dioxide to myrcenol, myrcenal, and myrcenic acid.

Use.—β-Myrcene has not found any noteworthy use in the perfume and flavor industries.

¹ *Helv. Chim. Acta* **7** (1924), 272.

² *Bull. soc. chim.* [5], **4** (1937), 422.

³ *Pharm. Rundschau* New York **13** (1895), 60.

⁴ Chapman, *J. Chem. Soc.* **83** (1903), 506. *J. Inst. Brew.* **35** (1929), 247. Semmler and Mayer, *Ber.* **44** (1911), 2009.

⁵ Barbier, *Bull. soc. chim.* [3], **25** (1901), 691.

⁶ *Pharm. Rundschau* New York **13** (1895), 61.

⁷ *Ber.* **34** (1901), 3126.

⁸ "Over Ocimeen en Myrceen," *Inaug. Diss. Utrecht* (1905).

⁹ *Compt. rend.* **203** (1936), 733.

¹⁰ *Ber.* **46** (1913), 1566.

¹¹ *Ber.* **67** (1934), 1944.

¹² *Liebigs Ann.* **470** (1929), 81.

¹³ *Helv. Chim. Acta* **19** (1936), 423.

¹⁴ *J. Organic Chem.* **7** (1942), 397.

¹⁵ *Rec. trav. chim.* **58** (1939), 783.

¹⁶ *J. Am. Chem. Soc.* **55** (1933), 1554.

¹⁷ *Bull. soc. chim.* [5], **4** (1937), 425.

¹⁸ *Ber.* **44** (1911), 2009.

¹⁹ *J. Russ. Phys. Chem. Soc.* **45** (1913), 1324.

²⁰ *J. Chem. Soc.* **83** (1903), 506.

²¹ *Rec. trav. chim.* **26** (1907), 166.

²² *Chem. Weekblad* **3** (1906), 653, 685, 701; **4** (1907), 41.

²³ *Ber. Schimmel & Co.*, April (1895), 11.

²⁴ *Bull. acad. sci. U.R.S.S. Classe sci. chim.* (1940), 267. *Chem. Abstracts* **35** (1941), 4730.

²⁵ *Ber.* **35** (1902), 3264.

²⁶ *Pharm. Rundschau* New York **13** (1895), 60.

²⁷ *Atti X^o congresso intern. chim.* **3** (1939), 120. *Chem. Abstracts* **33** (1939), 8194.

SUGGESTED ADDITIONAL LITERATURE

W. J. Runckel and L. A. Goldblatt, "Inhibition of Myrcene Polymerization During Storage," *Ind. Eng. Chem.* **38**, No. 7 (1946), 749.

Ocimene

C₁₀H₁₆

Mol. Weight 136.23

2,6-Dimethyl-1,5,7-octatriene

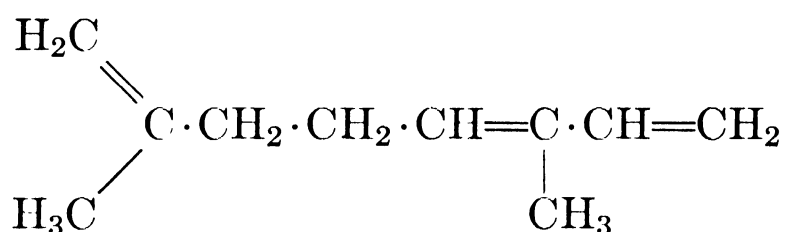

According to Dupont and Desreux,¹ this structural formula of α -ocimene, established by Enklaar,² does not apply to ocimene as it occurs in nature. Studying the Raman spectrum of an ocimene of van Romburgh,³ these authors suggested the following structural formula of β -ocimene:

2,6-Dimethyl-2,5,7-octatriene

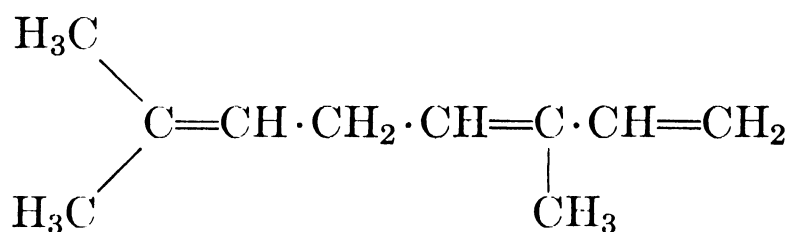

The divergent configurations of the α - and β - structure of this hydrocarbon, however, might possibly be a result of the method of isolation.

Occurrence.—First isolated by van Romburgh⁴ from the Javanese oil of *Ocimum basilicum* L. var. *Selasih besar*, ocimene occurs also in *Ocimum gratissimum*.⁵ Lahey and Jones⁶ reported it in *Evodia littoralis*, Huzita⁷ in oil of *Orthodon linaloöliferum* Fujita, and Penfold⁸ in the ethereal oil from the leaves and twigs of *Eriostemon myoporoides* D.C. It also occurs in a few other oils, probably in estragon oil. Crabalona⁹ reported the presence of ocimene in the first fractions of French lavender oil.

Isolation.—The essential oil distilled from the fresh leaves of *Ocimum basilicum* var. *Selasih besar* is treated with sodium hydroxide solution, whereby the eugenol (30% to 46% of the oil) is removed. From the undissolved portions of the oil, and by repeated vacuum fractionation, van Romburgh¹⁰ thus obtained ocimene as a main constituent.

Identification.—Ocimene does not yield any characteristic crystalline compounds. Identification is, therefore, accomplished:

(1) By reduction with sodium and alcohol to dihydromyrcene, and bromination. Tetrabromodihydromyrcene *m.* 88° (Enklaar).

(2) By hydration with sulfuric acid (50%) in glacial acetic acid solution, according to Bertram and Walbaum,¹¹ an alcohol, *viz.*, ocimenol, is obtained. Ocimenol phenylurethane *m.* 72° (Enklaar).

(3) Oxidation of ocimene with potassium permanganate either in alkaline or in acetone solution results in very complete degradation and in the formation of acids, the lead salts of which crystallize in rhombic form; whereas myrcene, if treated in the same manner, yields a lead salt crystallizing in needle form. Myrcene can thus be identified in the presence of ocimene.

Properties.—Van Romburgh¹² and Enklaar¹³ reported the following properties:

b.	176°–178° ¹² (with decomposition)	d_{22}	0.794 ¹²
b_{30}	81° ¹³	d_{15}	0.8031 ¹³
b_{21}	73°–74° ¹²	n_D^{18}	1.4857 ¹³

These properties have been confirmed in the recent work of Asahina¹⁴ on an α -ocimene obtained from the fruit of *Evodia rutacarpa* Hook.

Ocimene oxidizes most readily and, on short exposure to air, forms a yellow resin. In the absence of oxygen, however, ocimene can be preserved unaltered.

Enklaar¹⁵ found that, on heating for a few hours in a neutral atmosphere, ocimene is converted into an isomeric hydrocarbon, *viz.*, *allo*-ocimene.

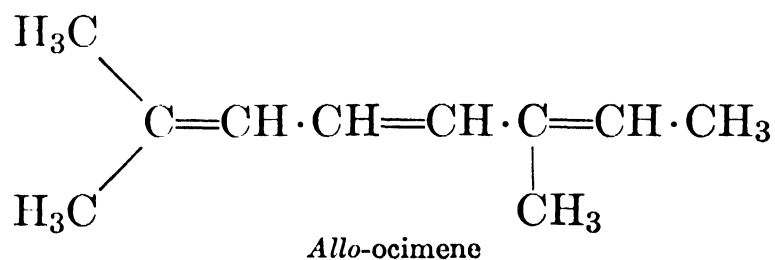

b_{12}	81°
d_{15}	0.8182
n_D^{16}	1.5296

Enklaar's structural formula for *allo*-ocimene was confirmed by Dupont and collaborators¹⁶ through Raman spectra determinations.

Two of the four possible stereoisomers of *allo*-ocimene have been described by Hopfield, Hall and Goldblatt¹⁷ as follows:

<i>m.</i>	b_{20}	d_4^{20}	n_D^{20}
–21° to –20.6°	89.0°	0.8060	1.5446
–35.4° to –34.0°	91.0°	0.8118	1.5446

Both yield an adduct with maleic anhydride melting at 83°–84°.

Use.—Ocimene has not found any noteworthy use in the perfume or flavor industries.

- ¹ *Bull. soc. chim.* [5], **5** (1938), 337.
- ² *Rec. trav. chim.* **26** (1907), 157; **27** (1908), 422; **36** (1917), 215; **45** (1926), 337.
- ³ *Proc. K. Acad. Wetensch. Amsterdam* **3** (1900), 446. *Ber. Schimmel & Co.*, April (1901), 11.
- ⁴ *Ibid.*
- ⁵ Roberts, *J. Soc. Chem. Ind.* **40** (1921), 164 T. Chiris, *Parfums France* **7** (1929), 186.
- ⁶ *Univ. Queensland Papers, Dept. Chem.* **1**, No. 13 (1939). *Chem. Abstracts* **34** (1940), 2133.
- ⁷ *J. Chem. Soc. Japan* **62** (1941), 424. *Chem. Abstracts* **36** (1942), 6743.
- ⁸ *J. Proc. Roy. Soc. N. S. Wales* **59** (1925), 208.
- ⁹ *Recherches* **2** (1938), 155. *Chem. Abstracts* **33** (1939), 4374.
- ¹⁰ *Proc. K. Acad. Wetensch. Amsterdam* **3** (1900), 446. *Ber. Schimmel & Co.* April (1901), 11.
- ¹¹ *J. prakt. Chem.* [2], **49** (1894), 1.
- ¹² *Proc. K. Acad. Wetensch. Amsterdam* **3** (1900), 446. *Ber. Schimmel & Co.* April (1901), 11.
- ¹³ *Rec. trav. chim.* **26** (1907), 161; **27** (1908), 422; **36** (1917), 215; **45** (1926), 337.
- ¹⁴ *Acta Phytochim. Japan* **1** (1922), 67. *Chem. Zentr.* III (1923), 248.
- ¹⁵ *Rec. trav. chim.* **26** (1907), 157; **27** (1908), 422; **36** (1917), 215; **45** (1926), 337.
- ¹⁶ *Bull. soc. chim.* [5], **5** (1938), 322.
- ¹⁷ *J. Am. Chem. Soc.* **66** (1944), 115.

∨ Cryptotaenene

$C_{10}H_{16}$

Mol. Weight 136.23

The structural formula of this terpene remains uncertain, and further research is indicated before any formula may be acceptable. Investigations in the past suggest either 2-methyl-2,4,8- or 2,6,8-nonatriene as a tentative structure.

Occurrence.—First observed by Hirano ¹ in the steam-distilled oil of *Cryptotaenia japonica* Hassk. fam. *Umbelliferae*.

Properties.—

b_{15}	$67^{\circ}-68^{\circ}$	$[\alpha]_D^{19.8}$	$+2^{\circ} 40'$
d_4^{25}	0.8128	n_D^{25}	1.47476

Use.—Cryptotaenene has not found any use in the perfume or flavor industries.

¹ *J. Soc. Chem. Ind. Japan* **29** (1926), 48. *Chem. Abstracts* **20** (1926), 1070.

B. AROMATIC HYDROCARBONS

Naphthalene

$C_{10}H_8$

Mol. Weight 128.16

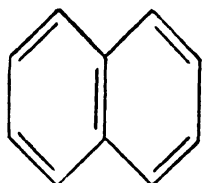

Occurrence.—Naphthalene has been found in oil of clove stems, orris root, and styrax.

Isolation.—By fractional distillation. (See also next section.)

Identification.—Naphthalene forms molecular addition compounds with a large number of compounds. These are useful as a means of identifying this hydrocarbon and include the following recommended derivatives:

- (a) 1,1-Complex with 3,5-dinitrobenzoic acid, m. 182° (Sinomiya ¹).
- (b) 1,3-Complex with α -dinitroaniline, m. 154° (Sinomiya ²).
- (c) Complex with 3,5-dinitro-*o*-cresol, m. 94° (Dermer and Smith ³).
- (d) Complex with ethyl-3,5-dinitrosalicylate, m. 78° (Dermer and Smith ⁴).
- (e) Complex with 2,4,6-trinitrobenzaldehyde, m. 136.5° (Dermer and Smith ⁵).
- (f) Complex with styphnic acid, m. 168°–169° (Ma, Hsia and Sah ⁶).
- (g) Complex with picric acid, m. 150.5° (Huntress and Mulliken ⁷).
- (h) Complex with sym-trinitrobenzene, m. 155.2°–155.8° (Jones and Neuworth ⁸).

These and similar addition compounds are also quite often useful as a means of isolating and purifying naphthalene.

Properties.—The following properties have been reported in the course of careful studies on naphthalene by Burriel,⁹ Timmermans and Burriel,¹⁰ Michel,¹¹ Mortimer and Murphy,¹² Marti,¹³ deBeule,¹⁴ Eppley,¹⁵ von Steiger,¹⁶ and Deffet and Vlerick:¹⁷

m.	80.06° ⁹
	80.10° ^{10, 11, 12, 13}
	80.21°–80.23° ¹⁴ (from ether)
b.	217.96° ^{9, 10, 13}
	217.973° ¹⁵
$d_4^{85.3}$	0.9757 ¹⁶
$d^{80.01}$	0.97865 ¹⁷ (liquid)
	(variation per degree 82° \rightarrow 115° 0.000811)
d^{60}	1.141 \pm 0.004 ¹⁷ (solid)
$n_D^{85.3}$	1.58996 ¹⁶

The values recorded by Eppley ¹⁸ for t over a wide range of vapor pressures were determined from this equation: $\log t_p = 0.20248 \log p + 1.755102$.

Illari ¹⁹ reported the initial temperature of sublimation at 762 mm. as 50° and that at 7 mm. as 22°.

Naphthalene is easily volatile with steam. According to Mitchell,²⁰ 0.022 g. of the hydrocarbon will dissolve per 100 g. of water at 15°. The solubility in hexane is reported by Ward ²¹ as

0.2 g. in 2.035 g. of hexane at 8.7°,
3.0 g. in 0.367 g. of hexane at 72.5°.

Naphthalene is sparingly soluble in cold petroleum ether; moderately soluble in methyl alcohol and in cold ethyl alcohol; and readily soluble in most other organic solvents.

Use.—Naphthalene as such is not used in the perfume or flavor industries.

- ¹ *J. Chem. Soc. Japan* **59** (1938), 922. *Chem. Abstracts* **33** (1939), 563.
- ² *Ibid.*
- ³ *J. Am. Chem. Soc.* **61** (1939), 748.
- ⁴ *Ibid.*
- ⁵ *Ibid.*
- ⁶ *Science Repts. Natl. Tsing Hua Univ.* **2** (1933), 151. *Chem. Abstracts* **28** (1934), 3692.
- ⁷ "Identification of Pure Organic Compounds," Order I, 507. See also Mulliken "Identification of Pure Organic Compounds," Method I (1904), 201.
- ⁸ *J. Am. Chem. Soc.* **66** (1944), 1499.
- ⁹ *Anales soc. españ. fís. quím.* **29** (1931), 89.
- ¹⁰ *Chimie & industrie*, Spec. No. 25 (1931), 196.
- ¹¹ *Bull. soc. chim. Belg.* **48** (1939), 135.
- ¹² *Ind. Eng. Chem.* **15** (1923), 1140.
- ¹³ *Bull. soc. chim. Belg.* **39** (1930), 591.
- ¹⁴ *Ibid.* **40** (1931), 195.
- ¹⁵ *J. Franklin Inst.* **205** (1928), 392.
- ¹⁶ *Ber.* **55** (1922), 1972.
- ¹⁷ *Bull. soc. chim. Belg.* **51** (1942), 237. *Chem. Abstracts* **38** (1944), 4500.
- ¹⁸ *J. Franklin Inst.* **205** (1928), 391.
- ¹⁹ *Ann. chim. applicata* **21** (1931), 127.
- ²⁰ *J. Chem. Soc.* (1926), 1336.
- ²¹ *J. Phys. Chem.* **30** (1926), 1326.

SUGGESTED ADDITIONAL LITERATURE

Iserman, "The Relationship of the Chemistry of Perfumes to Other Branches of the Organic Chemical Industry," *Prog. Perfumes and Cosmetics* (1938), 37.

Styrene

C₈H₈

Mol. Weight 104.14

Styrol. Styrolene. Vinylbenzene. Phenylethylene

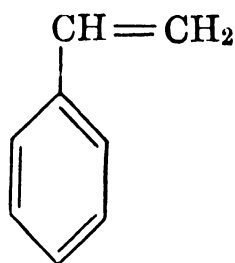

Occurrence.—This simple aromatic hydrocarbon probably originates in essential oils by the degradation of cinnamic acid. It occurs in various styrax oils and in the oil from Honduras balsam.

Isolation.—By fractional distillation *in vacuo*.

Identification.—By the preparation of the dibromide C₆H₅CHBr·CH₂Br, m. 74°–75° (from 80% alcohol), according to van Duin,¹ and Reed and Reid.²

In order to prepare this dibromide, Evans and Morgan,³ using a modified Zincke⁴ method, recommended:

"To a solution of 48.5 g. (1 mol.) of freshly distilled styrene in 400 cc. of pure ether were added 126.8 g. of bromine dissolved in 600 cc. of ether. The solution of styrene was placed in an open beaker surrounded by ice water and it was kept in

constant motion by a mechanical stirrer. The rate of flow of the bromine solution was regulated by the discharge of color, from red to a very light yellow. The whole operation was most advantageously carried on in direct sunlight."

The crude product obtained by distilling off the ether is purified by recrystallization from alcohol.

Steinkopf and Kühnel⁵ prepared the pseudonitrosite m. 133° by action of nitrosyl chloride on styrene. Alder, Pascher and Vagt⁶ condensed styrene with dimethyl ester of acetylene dicarboxylic acid. These authors report that a tetramethyl ester m. 107°–108° is derived from this reaction, and a dianhydride m. 260°.

Properties.—Styrene is a colorless, strongly refractive liquid possessing a characteristic and peculiar odor, reminiscent of illuminating gas.

The properties of a highly reliable sample of styrene have been reported by Waterman and deKok.⁷

f.p.	−33°	d_4^{20}	0.9090
m.	−33°	$n_D^{20.05}$	1.54633
b.	145°–145.8°		
b_{20}	48°		

A publication by Wood and Higgins⁸ at the U. S. National Bureau of Standards summarizes reliable data recently gathered on this hydrocarbon. These authors report:

f.p.	−30.6°	d_{20}	0.9056 *
b.	145.2°	n_D^{25}	1.5443

On storing outside the refrigerator and especially on heating or on contact with acids, styrene polymerizes to metastyrene (C_8H_8)_n, a transparent, colorless, and odorless mass. According to Stobbe,⁹ an equilibrium is finally reached: styrene \rightleftharpoons metastyrene.

Use.—Styrene is not much used in the perfume or flavor industries.

¹ *Rec. trav. chim.* **45** (1926), 354.

² *J. Chem. Soc.* (1928), 1488.

³ *J. Am. Chem. Soc.* **35** (1913), 56.

⁴ *Liebigs Ann.* **216** (1883), 288. Radziszweski, *Ber.* **6** (1873), 493.

⁵ *Ber.* **75B** (1942), 1327.

⁶ *Ber.* **75B** (1942), 1514.

⁷ *Rec. trav. chim.* **53** (1934), 1134.

⁸ *India Rubber World* **107** (1943), 475. See Letter Circular LC-710 U. S. Dept. of Commerce, National Bur. Stds., Washington, D. C., Dec. 9, 1942.

⁹ *Ber.* **47** (1914), 2701.

SUGGESTED ADDITIONAL LITERATURE

Rolf E. Schneider (to the Lummus Co.), "Styrene Distillation," U. S. Patent No. 2,385,235, September 18, 1945. *Chem. Abstracts* **40** (1946), 359.

* Values for d are given from 0° to 145° C. Cf. Patnode and Scheiber, *J. Am. Chem. Soc.* **61** (1939), 3449.

Agropyrene

C₁₂H₁₂

Mol. Weight 156.22

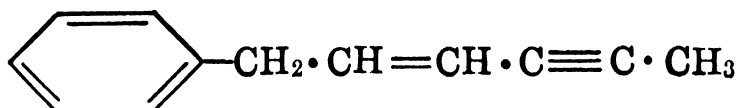

Occurrence.—Agropyrene is the first hydrocarbon with an ethylenic and an acetylenic linkage observed in nature. According to Treibs¹ the volatile oil derived from the root of *Agropyrum repens* (*Triticum repens*) consists almost entirely (95 per cent) of agropyrene.

Isolation.—By fractional distillation *in vacuo*.

Identification.—By determination of the physicochemical properties, and by hydrogenation to hexahydroagropyrene C₁₂H₁₈ (= *n*-phenylhexane).

Properties.—

b ₁₀	140°–143°
d ₂₀	0.9744
n _D ²⁰	1.5695

When freshly distilled, agropyrene is a light-yellowish liquid, which on standing and on exposure to light, rapidly assumes a deep yellow color. The odor is characteristic, lasting and sweetish, reminiscent of methyl chavicol and isochavibetol. When heated to boiling temperature at atmospheric pressure, agropyrene polymerizes rapidly to a viscous brown mass.

Use.—Agropyrene is not used in our industries.

¹ *Chem. Ber.* **80**, No. 2 (1947), 97.

∨ *p*-Cymene

“Cymol”

C₁₀H₁₄

Mol. Weight 134.21

1-Methyl-4-isopropylbenzene

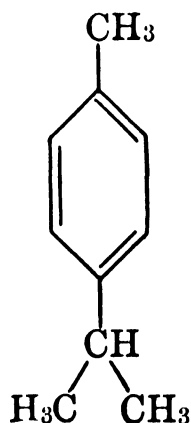

Occurrence.—*p*-Cymene occurs in numerous volatile oils—for example, in Swedish and Russian turpentine oil, in oil of lemon, sage, thyme, origanum, savory, coriander, ajowan, angelica, cumin, olibanum, nutmeg, star anise,

cinnamon, etc. In many cases where *p*-cymene has been reported in an oil, it may have been formed by conversion from cyclic terpenes such as pinene, terpinene, or from terpene derivatives, for instance, carvone, dihydrocarvone, carvenone, thujone, citral, sabinol, cuminyl alcohol, etc.

The so-called commercial "thymene" consists mainly of *p*-cymene.

Isolation.—By fractional distillation. The *p*-cymene fraction can be freed from terpenes of similar boiling point by oxidation with dilute potassium permanganate solution in the cold, *p*-cymene being quite resistant to this oxidizing agent. Any cineole present in the same fraction is removed through its hydrobromide.

Identification.—*p*-Cymene may be characterized by several methods:

(1) Oxidation with a hot and concentrated solution of potassium permanganate yields *p*-hydroxyisopropylbenzoic acid m. 155°–156°. Wallach¹ recommended this procedure:

"Reflux on the steam bath 2 g. of the purified hydrocarbon with a solution of 12 g. of potassium permanganate in 330 g. of water and shake frequently. After completion of the oxidation, evaporate the solution, freed from MnO₂, to dryness and extract the salt residue with boiling alcohol. Decompose the alcohol-soluble potassium salt with dilute aqueous sulfuric acid and recrystallize the separating acid from alcohol."

Meyer and Rosicki² found that, on heating with dilute hydrochloric acid, the *p*-hydroxyisopropylbenzoic acid loses water and forms *p*-isopropenylbenzoic acid m. 160°–161°.

(2) Schorger³ reported that *p*-cymene, when treated with fuming sulfuric acid, yields simultaneously 1,2,4- and 1,3,4-cymenesulfonic acid and a disulfonic acid. From the 1,2,4-sulfonic acid isolated first from the reaction mixture, a sulfamide m. 115°, may be prepared and carvacrol on melting with alkali. The 1,3,4-sulfonic acid gives a sulfamide m. 149.9°, and on melting with alkali, thymol, according to Phillips.⁴

Properties.—*p*-Cymene is a colorless liquid, optically inactive, possessing an odor typical of the aromatic hydrocarbons.

Bert⁵ reported for a pure *p*-cymene prepared from thymol:

b.	175°–176°
d_4^{20}	0.857
n_D^{20}	1.4917

International Critical Tables⁶ report b. 175.9°.

Richter and Wolff⁷ prepared *p*-cymene by various methods and observed these properties:

<i>p</i> -Cymene from	m.	b. (corr.)	d_4^{20}	n_D^{20}
Camphor	−72.3°	177.3°–177.4°	0.8570	1.4904
Finnish cellulose	(−67.7°)	177.3°	0.8570	1.4904
German cellulose	...	177.4°–177.6°	0.857	1.4894
Ajowan oil	...	177.4°–177.5°	0.856	1.4899

The cymene from camphor is to be regarded as the most nearly pure.⁸

On treatment with dilute nitric acid and with chromic acid mixture, *p*-cymene is oxidized to *p*-toluic acid and finally to terephthalic acid.

Use.—*p*-Cymene is widely used for the scenting of soaps and all kinds of technical preparations where it serves to overcome undesirable odors. *p*-Cymene also forms an important constituent in the compounding of certain imitation essential oils.

¹ *Liebigs Ann.* **264** (1891), 10.

² *Ibid.* **219** (1883), 282.

³ *J. Ind. Eng. Chem.* **10** (1918), 258. Cf. Claus, *Ber.* **14** (1881), 2140.

⁴ *J. Am. Chem. Soc.* **46** (1924), 686.

⁵ *Bull. soc. chim.* [4], **37** (1925), 1251.

⁶ Vol. III, 347.

⁷ *Ber.* **63** (1930), 1721.

⁸ Refer also to the statement of Timmermans, *Bull. soc. chim. Belg.* **30** (1921), 65; Perkin, *J. Chem. Soc.* **69** (1896), 1194; and Karvonen, *Ber.* **56** (1923), 1824.

SUGGESTED ADDITIONAL LITERATURE

E. Boedtker, "Cymene, a By-product in the Manufacture of Sulfite Cellulose," *J. pharm. chim.* [8], **9** (1929), 417. *Chem. Abstracts* **24** (1930), 78.

Irvin W. Humphrey (to Hercules Powder Co.), "Cymene," U. S. Patent No. 1,746,532, February 11, 1930. *Chem. Abstracts* **24** (1930), 1653.

C. E. Senseman and J. J. Stubbs, "Catalytic Oxidation of *p*-Cymene in the Liquid Phase," *Ind. Eng. Chem.* **24** (1932), 1184. *Chem. Abstracts* **26** (1932), 5924.

Yasuji Fujita and Saburo Ohashi, "Oxidation of *p*-Cymene with Hydrogen Peroxide," *J. Chem. Soc. Japan* **63** (1942), 93. *Chem. Abstracts* **41** (1947), 3174.

Brun, "Preparation of Cymenes," *Bull. soc. chim.* **12** (1945), 452. *Chem. Abstracts* **40** (1946), 847.

Washington Hull (to American Cyanamid Co.), "Preparation of *p*-Cymene by the Vapor-Phase, Dehydrogenation of Monocyclic Terpenes," U. S. Patent No. 2,388,359, November 6, 1945. *Chem. Abstracts* **40** (1946), 1879.

Chas. T. Lester and Carroll F. Bailey, "Studies in *p*-Cymene. The Saponification Rate of Isomeric Benzoates Derived from *p*-Cymene," *J. Am. Chem. Soc.* **68** (1946), 375.

C. CYCLIC TERPENES

(a) MONOCYCLIC TERPENES.

Introduction.—Structurally, these terpenes have as their parent substances homologues of cyclohexane from which they are derived by varying degrees of dehydrogenation. Usually, a methyl-isopropylcyclohexanol is described as the parent molecule, and the monocyclic terpenes are thus theoretically derived from one of the three isomeric menthanes (*ortho*, *meta* or *para*).

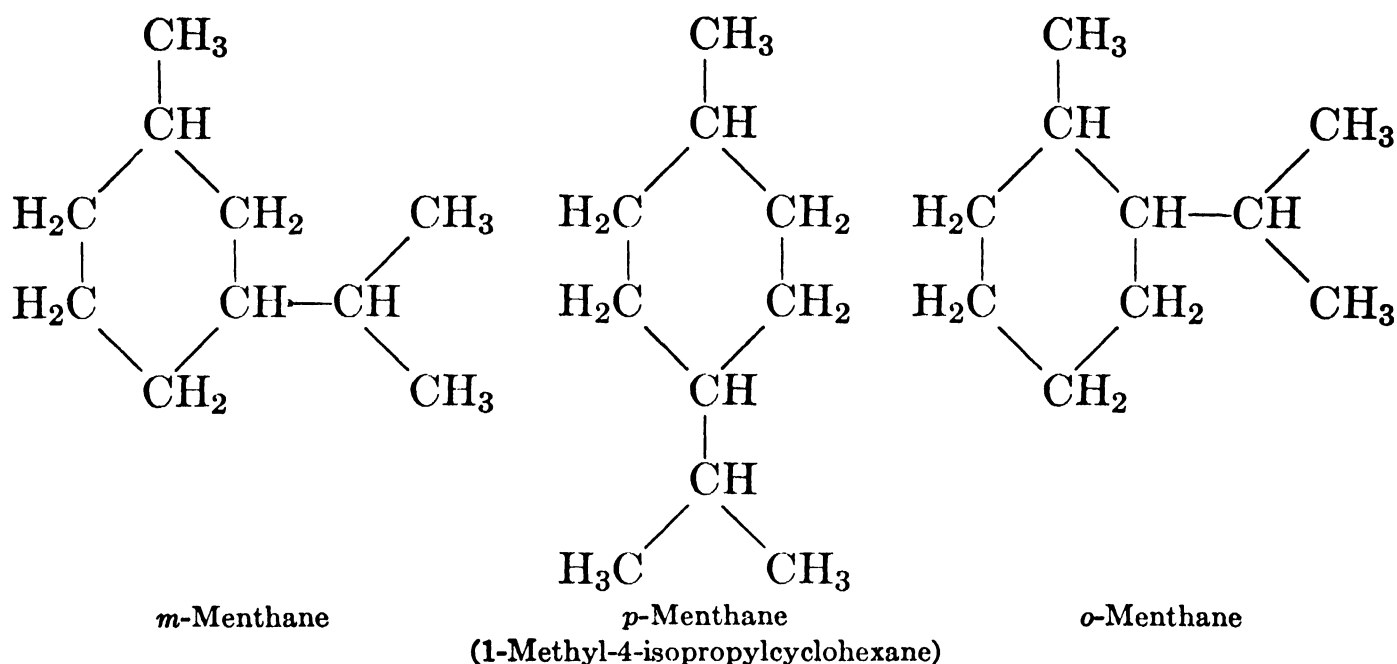

For convenience, our description will be confined to the *p*-isomer, as it is architecturally related to several important natural terpenes. However, parallel conclusions may often be drawn for the *ortho* and *meta* compounds, which are primarily synthetic.

Theoretically, then, various degrees of dehydrogenation of the *para* menthane will yield the menthenes, the menthadienes and *p*-cymene or rare trienes, some of which, either in themselves or as derivatives, are found as important ingredients in many natural products. Several skeletal isomers are illustrated here.

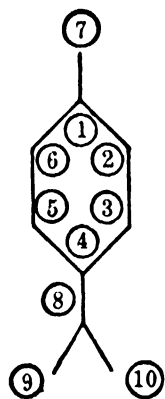
*p*-Menthane

(1-Methyl-4-isopropylcyclohexane)

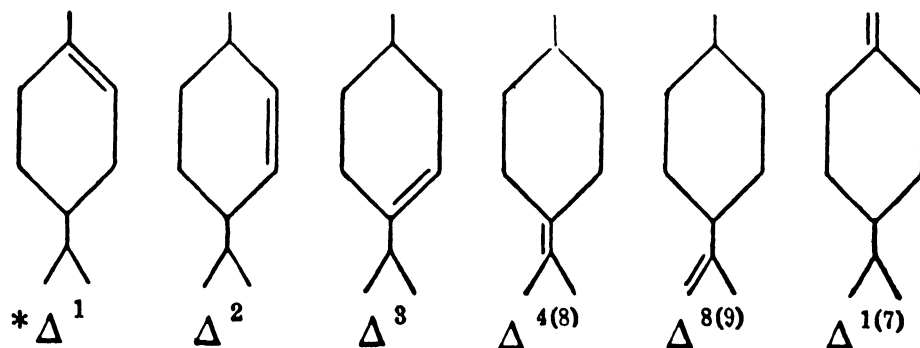
*p*-Menthenes

* Although the use of " Δ " to illustrate the existence of a double bond in the carbon system is still recognized, and pictured here only for convenience, this practice is lately generally discouraged, and thus will not be further encountered in these pages on the *monocyclic* terpenes.

All members of this group have been synthetically characterized but the most important, as related to the essential oils, is Δ^3 -menthene which is a natural constituent of thyme oil and closely related to menthol, principal constituent of peppermint oil.

The second degree of dehydrogenation of *p*-menthane produces the dihydro-*p*-cymenes or *p*-menthadienes. Only a few of the many theoretically possible isomers have been encountered in natural products but these few belong to some of the most important constituents of essential oils. Moreover, many of their derivatives, too, are of major importance—for example, the menthols, terpineols, and piperitols. The following represent plane figure compounds of this group, illustrating isomers by shifting of the double bonds:

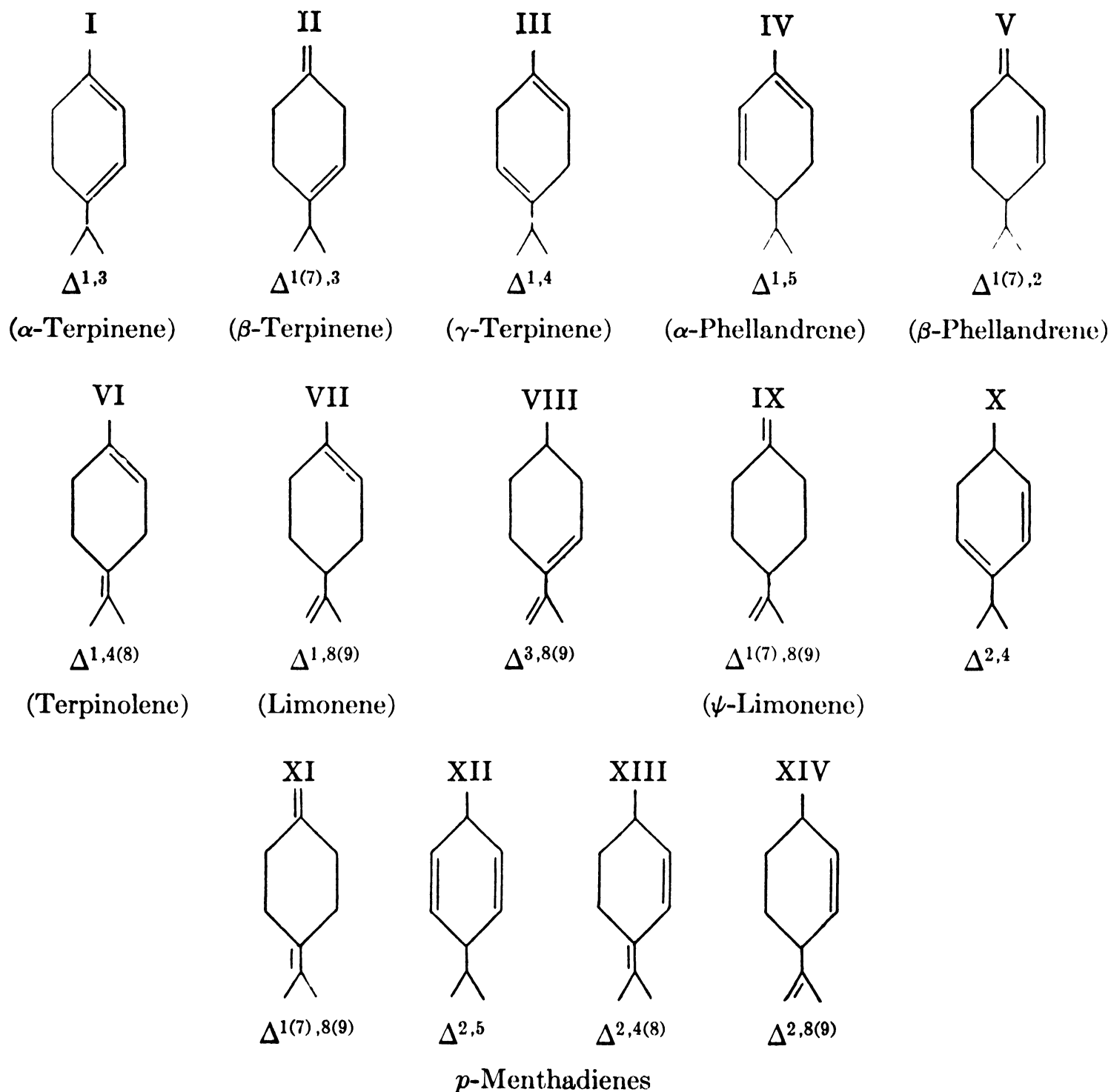

Of this group, α - and γ -terpinene, α - and β -phellandrene, terpinolene, and limonene are most frequently encountered in essential oils. They will be described in detail later for purposes of identification in essential oils.

One important feature should be considered in any diagnostic study undertaken in connection with monocyclic terpenes, i.e., some configurations allow for the existence of isomers. Such molecules theoretically permit several forms.

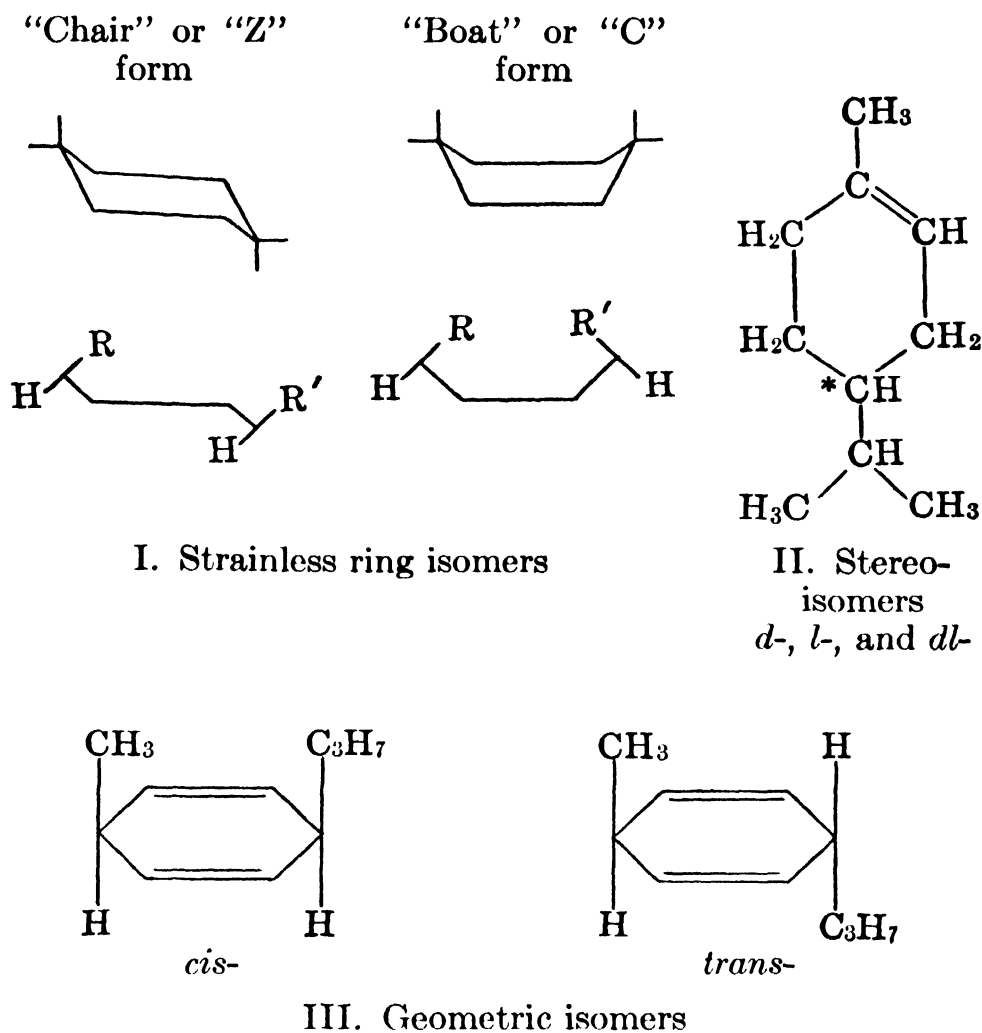

The worker, therefore, should ever be on the alert for complications that may beset his work of identifying menthanes, menthenes, or menthadienes.

Although cyclic hydrocarbons are generally more stable than the corresponding acyclic substances, the monocyclic terpenes isomerize, oxidize, and polymerize quite readily,¹ especially when distilled at atmospheric pressure. Thus, it remains questionable whether any of these terpenes have ever been prepared in absolutely pure form.

¹ In this connection, see Dupont, *Ind. chim. belge* **11** (1940), 3. *Chem. Abstracts* **34** (1940) 2353.

SUGGESTED ADDITIONAL LITERATURE

Arne Fredga and Esa Leskinen, “Configuration of Terpenes,” *Arkiv. Kemi, Mineral. Geol.* **B19**, No. 1 (1944), 6. *Chem. Abstracts* **41** (1947), 1616.

Theo Lennartz, “Biogenesis of Terpenes,” *Z. Naturforsch.* **1** (1946), 684. *Chem. Abstracts* **41** (1947), 5175.

∨ **Limonene**

C₁₀H₁₆

Mol. Weight 136.23

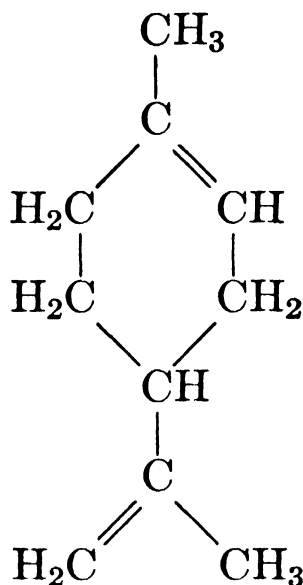
1,8(9)-*p*-Menthadiene. 1-Methyl-4-isopropenyl-1-cyclohexene

Occurrence.—Limonene is one of the most widely distributed terpenes, occurring in many volatile oils, in some as the main constituent, especially in the citrus oils.

d-Limonene (formerly called carvene or citrene) has been identified in oil of orange (about 90 per cent), lemon, mandarin, lime, grapefruit, bergamot, neroli, petitgrain, elemi, caraway (40 per cent), dill, fennel, celery (60 per cent), erigeron, orthodon oils, etc.

l-Limonene occurs in several pine needle oils, the cone oil of *Abies alba*, Russian turpentine oil, star anise, American wormseed, peppermint, spearmint, cajuput, *Eucalyptus staigeriana*, Congo copal resin, etc.

In many cases in which limonene has been recorded as a constituent of essential oils, the optical rotation is not given.

Isolation.—Limonene may be isolated from volatile oils by fractional distillation and by redistillation over metallic sodium. The crude limonene is finally purified, according to Godlevski,¹ by the preparation of its tetrabromide and by the reduction of the tetrabromide with zinc dust in alcoholic solution.

Another method for bromination is that of Gaponenkov² (see below), whereas for reduction the technique of von Braun and Lemke³ with metallic magnesium in ether may be employed. This latter procedure has been used by Rule and Chambers⁴ to prepare a pure sample of limonene.

Where the isolation is complicated by the presence of conjugated dienes, the technique of Johnston⁵ may be helpful through a fumaric acid reaction at 160°–185°. Conjugated hydrocarbons are thereby removed from the nonconjugated products.

An entirely different method, but yielding only 35% limonene, is that of Peleato⁶ which treats the limonene fraction in ether solution with mercuric acetate for 48 hr. The precipitate formed is then decomposed with aluminum and sodium carbonate, and the limonenes fractionated.

Identification.—In order to identify limonene, Wallach⁷ suggested preparing its tetrabromide. However, only oily products are obtained if the reagents used are not

M.P. OF THE DERIVATIVES IN °C.

Derivative	<i>d</i>	<i>l</i>	<i>dl</i>
Dihydrochloride	~25 (<i>cis</i>) ²¹ 49-50 (<i>trans</i>) ^{20,21}
Dihydrobromide	38-40 (<i>cis</i>) ²¹ 64 (<i>trans</i>) ^{20,21}
Dihydroiodide	<50 (<i>cis</i>) ²² 81 (<i>trans</i>) ²²
Tetrabromide	104-105 ¹⁷	104-105 ^{16,18}	125-126 ¹⁹
Nitrosochloride	(α) 103-104 ¹² (β) 105-106 ¹²	(α) 103-104 ^{12,13,16} (β) 105-106 ¹³ (β) 100 ¹²	(I) 78 ¹⁵ (II) 104 ¹⁵
Nitrosate	84 ¹⁴ (Decomp.)
Nitrolaniline	(α) 112-113 ^{12,15} (β) 153 ^{12,15}	(α) 112-113 ^{12,15} (β) 153 ^{12,15}	(α) 125 ^{12,15} (β) 149 ^{12,15}
Nitrolpiperidine	(α) 93-94 ¹² (β) 110-111 ¹²	(α) 93-94 ¹² (β) 110-111 ¹²	(α) 154 ¹² (β) 152 ¹²
Nitrolbenzylamine	(α) 93 ¹² ...	(α) 93 ¹² ...	(α) 110 ¹² ...
Adduct with (=CHCO) ₂ O	147 ²³	147 ²³	...

completely anhydrous. Baeyer⁸ obtained crystalline tetrabromides by brominating the terpene fraction in a solution of equal parts of amyl alcohol and ether and by evaporating the ether slowly. Godlevski⁹ recommended adding the solution of the terpene fraction in a mixture of equal parts of amyl alcohol and ether, drop by drop, to an ice-cold solution of bromine in ether. The mixture must be kept ice-cold throughout the reaction. Gaponenkov¹⁰ has recently stated that the reaction is best carried out by reversing this order of addition, using the same solvents.

The optically active tetrabromides m. 104°–105° crystallize best from ethyl acetate; $[\alpha]_D \pm 73^\circ 0'$ (in chloroform solution). The tetrabromide is either dextro- or laevorotatory, depending upon the optical rotation of the parent hydrocarbon.

Limonene gives a positive reaction with Bezssonoff's reagent¹¹ [$\text{MoO}_3 \cdot \text{WO}_3 \cdot (\text{P}_2\text{O}_5)_{17} \cdot 2\text{H}_2\text{O}$ dissolved in 5% H_2SO_4], whereby a blue color results in the presence of very small concentrations and serves to differentiate this terpene from many others.

The nitrosochlorides are also useful and have been amply described.

With organic primary or secondary bases the limonene nitrosochlorides yield monomolecular crystalline nitrolamines which are very well adapted for the identification of limonene. There exist six nitrosochlorides of limonene, viz., *d*-, *l*-, *dl*- α -nitrosochloride and *d*-, *l*-, *dl*- β -nitrosochloride. Thus each corresponding nitrolamine should also exist in six modifications. A number of these suitable derivatives are summarized below (Wallach,¹² Wallach and Conrady,¹³ Wallach,^{14,15} DuPont and Barraud,¹⁶ Wallach,^{17,18,19} Hell and Ritter,²⁰ Baeyer,²¹ Wallach,²² and Hultzsch²³):

Properties.—Apparently it has been difficult to prepare limonene free from isomers, for which reason the observations made by several authors are not always in good agreement. Limonene has been the subject of several important investigations, having their inception in the Born-Gans theory,^{24,25} relative to the determination of rotatory power.^{26,27,28} Naves and Angla²⁹ have already applied the principle of solvent effect on rotation in a method aiming at identifying terpenes, in particular limonene.

Properties listed below have been reported, after careful studies of both natural and synthetic isolates, by Lecat,³⁰ von Braun and Lemke,³¹ Pigulevski,³² Padmanabhan and Jatkar,³³ Staudinger and Geiger,³⁴ Pickett and Peterson,³⁵ Timmermans,³⁶ Auwers, Roth and Eisenlohr,³⁷ Richter and Wolff,³⁸ von Rechenberg,³⁹ Perkin,⁴⁰ Bruhl,⁴¹ Godlevski and Roshanovitch,⁴² Rule and Chambers,⁴³ and Peleato.⁴⁴

After experimenting on the oxidation of limonene with ozone, Escourrou⁴⁵ expressed the opinion that limonene always contains some terpinolene and α -terpinene; in other words, that limonene is a mixture of isomeric hydrocarbons difficult to separate. Thus the product examined by Escourrou consisted of 80 per cent limonene, 12 per cent terpinolene, and 8 per cent α -terpinene. The later work of Richter and Wolff,⁴⁶ however, would seem to indicate that, after elimination of the terpinolene contaminant, a limonene of high purity can be prepared.

Limonene is a colorless oil possessing a pleasant orange-like odor. When protected against access of air and light, limonene is comparatively stable; otherwise it oxidizes readily. It can be distilled at atmospheric pressure without decomposition.

Constant	<i>l</i>	<i>d</i>	<i>dl</i>
b.			
b ₇₆₀	...	177.6°–178° ^{30,36,37}	177.6°–178° ^{38,39,44}
b ₇₅₅	177.6°–177.8° ³⁸	177.6°–177.8° ³⁸	...
b ₂₀	...	71° ³³	...
b ₁₅	64.4° ³⁸	64.4° ³⁸	64.4° ³⁸
b ₁₃	...	60.5°–61° ⁴³	...
b ₁₀	54.5°–55.5° ³⁴
d			
	d ₄ ^{20.6} 0.8417 ³⁸	d ₄ ²⁵ 0.8409 ³³	d _{20.85} 0.8402 ⁴¹
	d ₄ ^{20.5} 0.8407 ⁴¹	d ₄ ²⁰ 0.8403 ⁴³	d ₁₅ ¹⁵ 0.8481 ³⁵
	d ₄ ¹⁴ 0.8472 ³⁸	d ₁₅ ¹⁵ 0.8498 ⁴⁰	...
	...	d ₄ ^{7.8} 0.8526 ³²	...
	...	d ₄ ⁴ 0.8576 ⁴⁰	...
	...	d ₀ 0.8584 ⁴²	...
[α] _D	[α] _D ²⁰ –122° 6' ³¹ [α] _D –121° ³⁸	[α] _D ²⁰ +126° 8' ³¹ [α] _D ¹⁶ +125° 6' ⁴²	
n _D	n _D ^{20.5} 1.47468 ⁴¹ n _D ^{17.2} 1.4727 ³⁸ n _D ¹⁴ 1.4740 ³⁸	n _D ²⁵ 1.4725 ³³ n _D ²¹ 1.47428 ⁴¹ n _D ²⁰ 1.4750 ³¹ n _D ¹⁷ 1.473 ³⁸ n _D ¹⁸ 1.4727 ³⁸ n _D ¹⁵ 1.4750 ⁴⁴

Mixing of *d*- and *l*-limonene yields the optically inactive dipentene. The latter is formed also if optically active limonenes are heated or treated with acids. Thus, limonene or dipentene, when treated with hydrogen chloride in the presence of moisture, yields dipentene dihydrochloride m. 50°–51° (from methyl alcohol). This dihydrochloride is best prepared by saturating a well-cooled solution of the terpene in glacial acetic acid, with hydrogen chloride. The action of acids in the cold may cause hydration, and formation of terpineol and terpin hydrate, but on heating these alcohols may be dehydrated again to hydrocarbons. On heating with mineral acids, limonene is converted to terpinene and some *p*-cymene. Oxidizing limonene with very dilute potassium permanganate solution, Wagner⁴⁷ obtained *p*-menthane-1,2,8,9-tetrol (limonetrine), m. 191.5°–192°. Milas and Sussman⁴⁸ later obtained this same tetraol, in 35 per cent yields, by oxidation with hydrogen peroxide in tertiary butyl alcohol in the presence of perosmic acid. Blumann and Zeitschel⁴⁹ showed that oxidation of limonene by moist air yields *dl*-carveol and *dl*-carvone, and, according to Sword,⁵⁰ 8(10)-*p*-menthene-1,2-diol, m. 67.5°.

Autoxidation of limonene to carvone and carveol under the influence of air and moisture most probably is one of the principal factors in the spoilage of poorly stored oils that contain a high percentage of limonene—citrus oils,

for example. This is particularly noticeable in old orange oils by a peculiar caraway-like by-note, whereas in lemon oil this off-note is masked by an odor of *p*-cymene originating perhaps from the oxidation of isocitral (see "Citral").*

Stronger oxygen concentrations, e.g., ozone, yield a solid ozonide m. 60°–65°, according to Neresheimer,⁵¹ but Spencer and co-workers⁵² find both mono- and diozonides of *d*-limonene and dipentene to be liquids.

Use.—Limonene is widely employed for the scenting of cosmetics, soaps and all kinds of technical goods, as well as for the flavoring of pharmaceuticals. A very important use is in imitation citrus oils, and generally in imitation essential oils.

In any contemplated use of limonene, however, the manufacturer should be aware that certain preliminary investigations are recommended since this product has been reported as the cause of dermatitis^{53, 54} and should be handled and compounded properly.

- ¹ *J. Russ. Phys. Chem. Soc.* **31** (1899), 203. *Chem. Zentr.* I (1899), 1241.
- ² *J. Gen. Chem. U.S.S.R.* **7** (1937), 994. *Chem. Abstracts* **31** (1937), 5340.
- ³ *Ber.* **56** (1923), 1562.
- ⁴ *J. Chem. Soc.* (1937), 152.
- ⁵ U. S. Patent to Amer. Cyan. Co. No. 2,290,054, July 14, 1942.
- ⁶ *Trabajos lab. bioquim. quim. apl.* [2], **1** (1940), 121. *Chem. Abstracts* **38** (1944), 2329.
- ⁷ *Liebigs Ann.* **225** (1884), 318; **239** (1887), 3; **252** (1889), 145.
- ⁸ *Ber.* **27** (1894), 448.
- ⁹ *Chem. Ztg.* **22** (1898), 827.
- ¹⁰ *J. Gen. Chem. U.S.S.R.* **7** (1937), 994. *Chem. Abstracts* **31** (1937), 5340.
- ¹¹ *Riechstoff Ind.* **13** (1938), 84.
- ¹² *Liebigs Ann.* **252** (1889), 111, 116, 118, 121, 126, 146. Cf. Wallach, "Terpene und Campher," Leipzig (1914), 271–282.
- ¹³ *Ibid.* **252** (1889), 111, 145. Cf. Wallach, "Terpene und Campher," Leipzig (1914), 271–282.
- ¹⁴ *Ibid.* **245** (1888), 270. Cf. Wallach, "Terpene und Campher," Leipzig (1914), 271–282.
- ¹⁵ *Ibid.* **270** (1892), 175, 181–188. Cf. Wallach, "Terpene und Campher," Leipzig (1914), 271–282.
- ¹⁶ *Bull. soc. chim.* [4], **35** (1924), 630.
- ¹⁷ *Liebigs Ann.* **227** (1885), 278.
- ¹⁸ *Ibid.* **246** (1888), 224.
- ¹⁹ *Ibid.* **225** (1884), 318.
- ²⁰ *Ber.* **17** (1884), 1978, 2610.
- ²¹ *Ibid.* **26** (1893), 2863.
- ²² *Liebigs Ann.* **281** (1894), 144 Anm.
- ²³ *Ber.* **72B** (1939), 1181.
- ²⁴ Born, *Physik. Z.* **16** (1915), 251. *Ann. Physik* [4], **55** (1918), 177.
- ²⁵ Gans, *Z. Physik.* **27** (1924), 164. *Ann. Physik* [4], **79** (1926), 547.
- ²⁶ Wolf and Volkmann, *Z. physik. Chem. Abt.* **B3** (1929), 139.
- ²⁷ Beckmann and Cohen, *J. Chem. Physics* **4** (1936), 784.
- ²⁸ Rule and Chambers, *J. Chem. Soc.* (1937), 145.
- ²⁹ *Compt. rend.* **213** (1941), 570.
- ³⁰ *Rec. trav. chim.* **45** (1926), 623.
- ³¹ *Ber.* **56B** (1923), 1563.
- ³² *J. Russ. Phys. Chem. Soc.* **54** (1924), 299.
- ³³ *J. Am. Chem. Soc.* **57** (1935), 334.
- ³⁴ *Helv. Chim. Acta* **9** (1926), 555.
- ³⁵ *Ind. Eng. Chem.* **21** (1929), 325.

* This theory, recently advanced by Strausz (*Perfumery Essential Oil Record* **38** (1947), 260), requires experimental proof, however. *The authors.*

- ³⁶ *Bull. soc. chim. Belg.* **27** (1913), 334. *Chem. Zentr.* I (1914), 618.
³⁷ *Liebigs Ann.* **373** (1910), 271.
³⁸ *Ber.* **63** (1930), 1724.
³⁹ "Einfache und Fraktionierte Destillation," 2nd Ed. (1923), 249.
⁴⁰ *J. Chem. Soc.* **81** (1902), 315.
⁴¹ *Ibid.* **91** (1907), 121.
⁴² *J. Russ. Phys. Chem. Soc.* **31** (1899), 209.
⁴³ *J. Chem. Soc.* (1937), 152.
⁴⁴ *Trabajos lab. bioquim. quim. apl.* [2], **1** (1940), 121. *Chem. Abstracts* **38** (1944), 2329.
⁴⁵ *Bull. soc. chim.* [4], **43** (1928), 1204.
⁴⁶ *Ber.* **63B** (1930), 1721.
⁴⁷ *Ber.* **23** (1890), 2315.
⁴⁸ *J. Am. Chem. Soc.* **59** (1937), 2345.
⁴⁹ *Ber.* **47** (1914), 2623.
⁵⁰ *J. Chem. Soc.* **127** (1925), 1632.
⁵¹ *Chem. Zentr.* II (1916), 993. Harries and Adam, *Ber.* **49** (1916), 1035.
⁵² *J. Organic Chem.* **5** (1940), 610.
⁵³ Schwartz, *Arch. Dermatol. Syphilol.* **37** (1938), 631.
⁵⁴ Riedel, *Klin. Wochschr.* **19** (1940), 1034. *Rev. Current Lit. Paint Colour Varnish and Allied Ind.* **15** (1942), 164. *Chem. Abstracts* **36** (1942), 7127.

SUGGESTED ADDITIONAL LITERATURE

Audrican, "Chemical Properties of Limonene," *Bull. inst. pin* (1927), 33-34, 55-56, 91-92, 183-190. A survey.

Yasuji Fujita and Saburo Ohashi, "Dehydrogenation of Limonene with Chloranil," *J. Chem. Soc. Japan* **63** (1942), 1443. *Chem. Abstracts* **41** (1947), 3175.

Morris S. Kharasch and Wm. B. Reynolds (to Research Corp.). "Limonene," U. S. Patent No. 2,382,641, August 14, 1945. *Chem. Abstracts* **40** (1946), 607.

V. N. Ipatieff, Herman Pines, Vladimir Dvorkovitz, R. C. Olberg, and Michael Savoy, "Studies in the Terpene Series. Cyclic Isomerization of Limonene," *J. Org. Chem.* **12** (1947), 34.

Dipentene

(dl-Limonene)

Occurrence.—Dipentene, the optically inactive (racemic) form of limonene, does not seem to be as widely distributed in nature as limonene. Also dipentene, wherever reported in an essential oil, may not be present as such, but may have been converted, by heating, fractionating, or by chemical action, from limonene or pinene.

Dipentene occurs in the following essential oils: in turpentine oils of various origin, in Siberian pine needle oil, and in oil of lemongrass, citronella, palmarosa, cardamom, pepper, cubeb, star anise, nutmeg, cinnamon leaves, camphor, bergamot, neroli, myrrh, olibanum, elemi, coriander, cumin, fennel, and many others.

Isolation.—When trying to separate dipentene from a mixture with limonene by the preparation of derivatives, it should be kept in mind that the dipentene derivatives usually separate first. When fractionating a mixture of hydrocarbons, or a volatile oil, dipentene, according to Wallach,¹ will be found in the fraction boiling slightly higher than limonene.

Dipentene can be isolated—for example, from Manila elemi oil—by fractional distillation. A good grade of dipentene is obtained by heating dipentene dihydrochloride with aniline or by treating dipentene tetrabromide with zinc dust and glacial acetic acid. For this purpose Wallach ² suggests heating 10 g. of dipentene dihydrochloride with 20 g. of aniline above a low flame until the reaction starts and, at the most, 2 or 3 min. longer. Add 20 cc. of glacial acetic acid and steam distill the mixture. Free the distillate from aniline by shaking repeatedly with oxalic acid solution and by steam distillation. Dry the product over anhydrous potassium carbonate and rectify over metallic sodium.

Other findings relevant to the isolation of this compound will be found in connection with limonene.

Identification.—The compound most suitable for the identification of dipentene is its (optically inactive) tetrabromide m. 124°–125° which may be prepared as described under limonene tetrabromide. Characteristic also is the nitrosochloride ³ m. 78° which, on further heating, may solidify and melt again at 103°–104°. When treated with alcoholic potassium hydroxide, the nitrosochloride yields *dl*-carvoxime m. 93°. When treated with benzylamine and alcohol, the nitrosochloride gives α -nitrobenzylamine m. 110°. ⁴ For details, see "Limonene." The derivatives of dipentene are optically inactive; they differ from those of limonene by a slight variation in the melting points.

Properties.—In regard to its physicochemical properties, dipentene differs from limonene only by its optical inactivity. The odor of dipentene is orange-lemon-like.

Comparative summary of the properties of dipentene may be observed in connection with limonene. Those reported by Richter and Wolff ⁵ are given here and represent a carefully prepared sample:

b.	178°
b ₁₅	64.4°
n _D ¹⁸	1.4727

Dipentene is relatively stable but heating causes polymerization. When heated with sulfuric acid in alcohol solution, dipentene is converted into terpinene. The action of 55 per cent sulfuric acid (1 part dipentene plus 6 parts sulfuric acid) at –6° yields terpin; whereas concentrated sulfuric acid gives *p*-cymene. When acted upon with halogen acids, dipentene and limonene form the same dihydrohalide compounds. (For the preparation, see "Limonene.") Dihydrochloride m. 49°–50°, dihydrobromide m. 64°, dihydroiodide m. 77°–81°. By removal of hydrogen halide, dipentene may be regenerated. When shaking the dihydrohalide compounds with dilute alkali solutions, α -terpineol and terpin hydrate are obtained.

Use.—The use of dipentene is similar to that of limonene.

¹ *Liebigs Ann.* **286** (1895), 138. *Ber.* **40** (1907), 600.

² *Ber.* **40** (1907), 603.

³ *Liebigs Ann.* **245** (1888), 267; **270** (1892), 175.

⁴ *Ibid.* **252** (1889), 126.

⁵ *Ber.* **63** (1930), 1724.

Isolimonene

C₁₀H₁₆

Mol. Weight 136.23

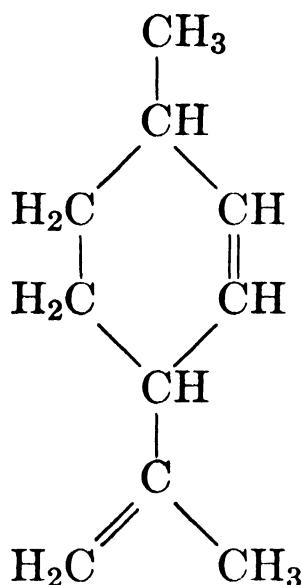
2,8(9)-*p*-Menthadiene. 1-Methyl-4-isopropenyl-2-cyclohexene

Occurrence.—This laevorotatory terpene was first observed in American wormseed oil *Chenopodium ambrosioides* var. *anthelminticum* by Kremers¹ and later investigated by Nelson,² and by Henry and Paget.³

Isolation.—By fractional distillation.

Identification.—By the preparation of the tetrabromide m. 117° which is optically inactive.

Properties.—The wide difference in the physicochemical characteristics as noted below indicates that the terpene has not been obtained in pure form by some of the workers. This compound has been studied by Henry and Paget,⁴ Slobodin,⁵ Tschugaev,⁶ Mereshkovski,⁷ Pigulevskii, et al.⁸ The variant properties recorded by these authors follow:

b.	177°–178° ⁴	[α] _D	–140° 35' ⁶
b.	173°–174° ⁸	[α] _D	–5° 55' ⁸
b.	172.5°–173.5° ⁶	[α] _D ¹⁵	–57° 0' ⁴
b _{758.6}	171°–173° ⁷	n _D ²⁰	1.484 ⁴
d ₄ ²⁰	0.8230 ⁷	n _D ²⁰	1.4606 ⁷
d ₄ ²⁰	0.8370 ⁶	n _D ²⁰	1.46693 ⁵
d _{19.5}	0.8390 ⁸	n _D ²⁰	1.47043 ⁶
d ₁₅	0.847 ⁴	n _D ^{19.5}	1.4750 ⁸

Use.—As such, isolimonene has not found any use in the perfume or flavor industries.

¹ *Pharm. Rev.* **25** (1907), 155.

² *J. Am. Chem. Soc.* **42** (1920), 1204.

³ *J. Chem. Soc.* **119** (1921), 1714; **127** (1925), 1649.

⁴ *Ibid.*, 1723.

⁵ *J. Gen. Chem. (U.S.S.R.)* **6** (1936), 129. *Chem. Abstracts* **30** (1936), 4828.

⁶ *J. Russ. Phys. Chem. Soc.* **36** (1904), 993.

⁷ *Bull. soc. chim.* IV, **37** (1925), 1184.

⁸ *J. Gen. Chem. (U.S.S.R.)* **7** (1937), 873. *Chem. Abstracts* **31** (1937), 5756.

SUGGESTED ADDITIONAL LITERATURE

G. V. Pigulevskii and I. Gorbunova, "The Isolimonene of Tschugaev," *Compt. rend. acad. sci. (U.S.S.R.)* **54** (1946), 499 (in French). *Chem. Abstracts* **41** (1947), 6551.

Terpinolene

$C_{10}H_{16}$

Mol. Weight 136.23

1,4(8)-*p*-Menthadiene. 1-Methyl-4-isopropylidene-1-cyclohexene

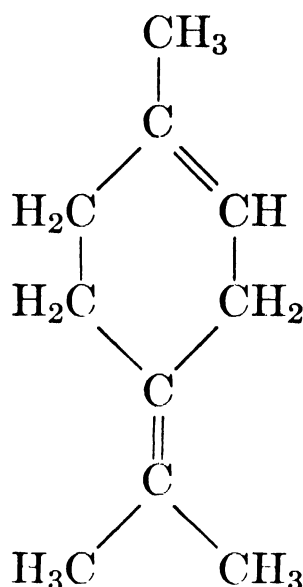

Occurrence.—In Manila elemi oil, according to Clover;¹ probably in coriander oil; in orange oil (?); and in the oil derived from Monterey cypress (*Cupressus macrocarpa*, Hartweg [syn. *C. Lambertiana*, Carr]), according to Briggs and Sutherland.²

Isolation.—By fractional distillation.

Identification.—(1) According to Wallach,³ terpinolene on treatment with bromine yields a dibromide m. 69°–70°, and a tetrabromide, viz., 1,2,4,8-tetrabromo-*p*-menthane m. 116° (119° and 122°, according to Henry and Paget⁴).

(2) Wallach⁵ found that terpinolene, on cautious oxidation with ice-cold potassium permanganate solution, is oxidized to an erythritol, viz., *p*-menthane-1,2,4,8-tetrol m. 149°–150°. These findings have been confirmed by Briggs and Sutherland.⁶

For the preparation of the erythritol 7 g. of the hydrocarbon are shaken in a copper still with 33 g. of crystalline potassium permanganate, 14 g. of potassium hydroxide, 400 g. of ice, and 400 cc. of water. The undigested hydrocarbon is distilled off, the oxidation liquid filtered from MnO_2 , and on the steam bath evaporated to dryness in a current of carbon dioxide. The residue is then extracted with alcohol and, after removal of the alcohol, dissolved in a little water and repeatedly extracted with ethyl acetate. The ester thereby extracts a neutral product which separates from the solvent, first in syrup form, but which may be brought to congealing by agitating

with cold ethyl acetate. After repeated recrystallization from ethyl acetate and water containing solvents, the product has a melting point ranging from 90° to 100° (with gas development). If dried slowly at 145°, the product has a melting point ranging from 149° to 150°.

(3) Hultsch⁷ found that the adduct with maleic anhydride (C₁₄H₂₀O₄) melts at 182° after numerous recrystallizations from ethyl acetate.

Properties.—The properties of this terpene have been reported by Semmler and Schossberger,⁸ Krestinski and Szolodki,⁹ Pickett and Peterson,¹⁰ Baeyer,¹¹ Wallach¹² and Zelinsky and Lewina:¹³

b.	186°–187° ⁹	d ₄ ²⁰	0.8628 ¹³
b.	183°–185° ¹¹	n _D ²²	1.4802 ¹³
b ₁₄	75° ^{8,13}	n _D ²⁰	1.4809 ¹⁰
b ₁₀	67°–68° ⁸		

At atmospheric pressure, terpinolene cannot be distilled without polymerization to high boiling compounds and, therefore, without considerable losses.

In the presence of mineral acids, terpinolene is very unstable and isomerized to terpinene; when treated in the cold with halogen acids in glacial acetic acid, dipentene dihydrohalides are obtained, according to Wallach.¹⁴

Use.—As a mixture with other terpenes, synthetic terpinolene, a secondary product in the manufacture of terpineol, is used for the scenting of all kinds of technical preparations.

¹ *Am. Chem. J.* **39** (1908), 613.

² *J. Org. Chem.* **7** (1942), 399.

³ *Liebigs Ann.* **227** (1885), 283.

⁴ *J. Chem. Soc.* (1931), 25.

⁵ *Liebigs Ann.* **368** (1909), 10, 13.

⁶ *J. Org. Chem.* **7** (1942), 397.

⁷ *Ber.* **72** (1939), 1182.

⁸ *Ber.* **42** (1909), 4644.

⁹ *Zhur. Prikladnoi Khim.* **2** (1929), 337. *Chem. Zentr.* II (1929), 2383.

¹⁰ *Ind. Eng. Chem.* **21** (1929), 325.

¹¹ *Ber.* **27** (1894), 448.

¹² *Liebigs Ann.* **291** (1896), 361.

¹³ *Ber.* **62** (1929), 341.

¹⁴ *Liebigs Ann.* **239** (1887), 24.

Sylvestrene

(dl-Sylvestrene = Carvestrene) $C_{10}H_{16}$

Mol. Weight 136.23

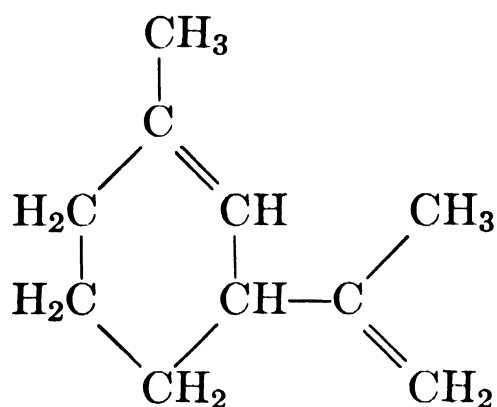
1,8(9)-*m*-Menthadiene. 1-Methyl-3-isopropenyl-1-cyclohexene6,8(9)-*m*-Menthadiene. 1-Methyl-3-isopropenyl-6-cyclohexene

and

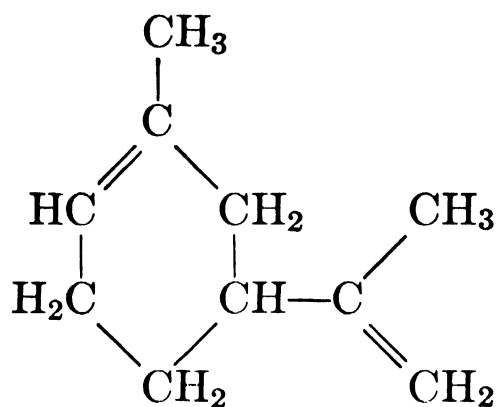

The numerous investigations of several workers, especially Haworth and Perkin,¹ prove conclusively that sylvestrene must be regarded as a mixture of the two hydrocarbons described above, in which either the one or the other form predominates. Sylvestrene exists in a dextro- and laevorotatory modification. The optically inactive (*dl*-) form is also called carvestrene.

Occurrence.—Sylvestrene was formerly believed to occur in Swedish pine needle oil, in Finnish oil of turpentine, in the oil from the roots of various pine species, and in cypress oil. Later Rao and Simonsen² proved that sylvestrene, as such, did not exist in nature, but that it is formed from either Δ^3 - or Δ^4 -carene during the process of isolation through the dihydrochloride. When passing gaseous hydrochloride through carene or a carene-containing fraction, sylvestrene dihydrochloride is formed. Sylvestrene, therefore, can no longer be regarded as a natural plant product.

Isolation.—According to Wallach,³ sylvestrene may be isolated in fairly pure form by preparing the dihydrochloride from a carene-containing fraction and by decomposing the dihydrochloride through boiling with aniline, with diethylaniline, or with sodium acetate and glacial acetic acid. For this purpose the fraction should first be diluted with an equal volume of anhydrous ether and saturated with absolutely dry gaseous hydrogen chloride. After two days of standing, the ether is driven off and the residue brought to crystallization at low temperature. The crystalline mass may be freed from adhering oil on porous clay plates. After recrystallization in the same weight of alcohol, the dihydrochloride is submitted to fractional crystallization. It is less soluble in ether than the corresponding dipentene compound. Dihydrochloride m. 72° . It should be kept in mind, in this connection, that the presence of dipentene or other terpenes yielding dipentene dihydrochloride with gaseous hydrochloride causes the formation of dihydrochloride mixtures. Their melting points will be lower, the higher the content of dipentene dihydrochloride. The sylvestrene separated through its dihydrochloride closely resembles limonene in regard to physicochemical properties.

Identification.—Sylvestrene forms, with solutions of glacial acetic acid—hydrogen halides, the following compounds:

<i>Derivative</i>	<i>Melting Points, Isomers</i>		
	<i>d</i>	<i>l</i>	<i>dl</i>
Dihydrochloride	72°	72°	52°
Dihydrobromide	72°	...	48°–50°
Dihydroiodide	66°–67°

Unlike dipentene dihydrochloride, which is optically inactive, the dihydrochloride of sylvestrene shows dextrorotation. On elimination of hydrogen chloride, the regenerated sylvestrene is optically active. The dihydrobromide cannot be obtained readily in crystalline form if other terpenes are present.

On addition of a drop of concentrated sulfuric acid, the terpene dissolved in acetic acid anhydride gives a very characteristic and intense methylene blue coloration.

The nitrosochloride m. 106°–107° which, according to Wallach,⁴ can be obtained by the action of amyl nitrite and hydrochloric acid on pure sylvestrene, is bimolecular, like limonene nitrosochloride, and dextrorotatory.

Properties.—Sylvestrene is a colorless mobile oil possessing an agreeable limonene-like odor. The following table summarizes properties of the different stereoisomeric forms as reported by Wallach,⁵ and Haworth, Perkin and Wallach;⁶ for *d*-sylvestrene regenerated from its hydrochloride by Schimmel & Co.,⁷ all applying to the dextroisomer. The laevo-form has been investigated by Haworth and Perkin,⁸ and a particular type regenerated from its dihydrochloride by Schimmel & Co.⁹ The *dl*-isomer or carvestrene has been the subject of work by Baeyer.¹⁰

Constants of the Isomers

<i>Property</i>	<i>d</i>	<i>l</i>	<i>dl</i>
b.	...	172°–180° ⁹	178° ¹⁰
b.	178°–182° ⁷	176°–178° ⁸	...
b ₇₅₁	175° ⁶
d ₂₀	0.848 ⁵
d ₁₉	...	0.848 ⁸	...
d ₁₅ ¹⁵	0.8659 ⁷	0.8604 ⁹	...
α _D	...	–68° 12' ⁸	...
[α] _D	+66° 19' ⁵ (in CHCl ₃)
[α] _D	+83° 11' ⁶
n _D ²⁰	1.47936 ⁷	1.47838 ⁹	...

Sylvestrene is one of the most stable terpenes; when heated to 250° it polymerizes but is not isomerized by heating or by the action of alcoholic sulfuric acid.

Use.—Sylvestrene, as such, has not found any noteworthy use in the perfume or flavor industries.

¹ *J. Chem. Soc.* **103** (1913), 2225. Cf. Baeyer, *Ber.* **27** (1894), 3490.

² *Ibid.* **127** (1925), 2494.

³ *Liebigs Ann.* **230** (1885), 241; **239** (1887), 25.

⁴ *Ibid.* **245** (1888), 272.

⁵ *Ibid.* **252** (1889), 149.

⁶ *Ibid.* **399** (1913), 159.

⁷ *Ber. Schimmel & Co.*, April (1914), 48.

⁸ *J. Chem. Soc.* **103** (1913), 2234.

⁹ *Ber. Schimmel & Co.*, April (1914), 48.

¹⁰ *Ber.* **27** (1894), 3491.

The Terpinenes

$C_{10}H_{16}$

Mol. Weight 136.23

The term "terpinene" refers to three monocyclic terpenes which, on treatment with hydrogen chloride, yield 1,4-dichloro-*p*-menthane (terpinene dihydrochloride). It is true that sabinene and thujene, too, give terpinene dihydrochloride but these terpenes are bicyclic and can easily be distinguished from the terpinenes. Of the three terpinenes, viz., α -, β -, and γ -terpinene only the α - and γ - isomer have been found in nature. Neither the α - nor the γ - form has been isolated in absolutely pure form as any terpinene fraction consists of a mixture of α - and γ -terpinene which are very difficult to separate.

Terpinene can be obtained artificially with great ease and by a multitude of reactions, from cyclic terpenes such as pinene, dipentene, phellandrene, sabinene, etc., or from oxygenated compounds like geraniol, linalool, terpineol, terpinenol, terpinene terpin, terpin hydrate, dihydrocarveol, cineole, etc. The resulting terpinene is always a mixture of several (usually α - and γ -) isomers, the composition of which varies with the method of preparation.

Terpinene possesses a great similarity to dipentene—for example, in regard to their halogen derivatives. Of the existing *cis*- and *trans*- modifications, only the latter are useful for identification, the former being liquid.

Isolation and Identification.—The fraction best suited for the identification of terpinene is that boiling from 175°–185° at 760 mm. The presence of terpinene suggests itself by the formation of terpinene dihydrochloride m. 52° when gaseous hydrogen chloride is passed into the hydrocarbon dissolved in glacial acetic acid. Thujene, sabinene, terpinenols, and terpinene terpin yield the same hydrochloride, but the boiling points of these compounds are partly lower, partly higher than those of the terpinenes.

Use.—The terpinenes are used in the compounding of certain synthetic essential oils, and in conjunction with other aromatics for the scenting of all kinds of technical preparations.

No comment about the use of the terpinenes would be complete without mention of the interest displayed by industry in its polymers formed with

α - and β - unsaturated compounds. Numerous patents ¹ have been granted on the use of complexes, from "terpinene" and maleic anhydride or fumaric acid, etc., for plasticizers, rubber substitutes, lacquers and varnishes, resins, and many other technical products.

¹ For example see: Hercules Powder Co., German Patent No. 625,903, Feb. 20, 1936. Hercules Powder Co., German Patent No. 633,420, July 27, 1936. Hercules Powder Co., German Patent No. 627,783, Mar. 23, 1936. Hercules Powder Co., U. S. Patent No. 1,993,025, Mar. 5, 1935. E. I. duPont de Nemours, U. S. Patent No. 2,144,464, Jan. 17, 1939.

 *α -Terpinene*C₁₀H₁₆

Mol. Weight 136.23

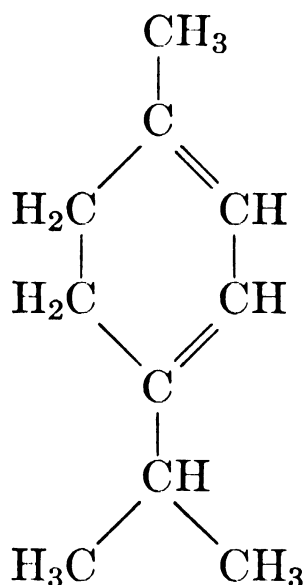
1,3-*p*-Menthadiene. 1-Methyl-4-isopropyl-1,3-cyclohexadiene

Occurrence.— α -Terpinene is the main constituent of "terpinene." It occurs in oil of savin, American wormseed, coriander, *Ocimum viride*, Ceylon cardamom, etc.

Isolation.— α -Terpinene can be isolated by fractional distillation—for example, from Ceylon cardamom oil—and by the preparation of terpinene dihydrochloride m. 52°. This is obtained, according to Wallach,¹ by treating the fraction b. 170°–220° with hydrogen chloride in ether solution. The dihydrochloride may be decomposed by heating with aniline as follows:

Heat 10 g. of terpinene dihydrochloride with 20 cc. of aniline until the reaction starts. Add 20 cc. of glacial acetic acid and steam distill the mixture. Shake the distillate, which contains considerable quantities of aniline, with oxalic acid solution. Drive off the hydrocarbon from the acid solution by steam distillation, shake the distillate once more with oxalic acid, and repeat the process until the distillate is absolutely free from aniline. Separate the hydrocarbon, dry, and distill over metallic sodium. The product thus obtained will also contain some γ -terpinene.

Another method of isolation that has yet to be tested upon a diverse number of mixtures but seems to be worthy of careful consideration is recommended by Tishchenko and Bogomolov ² who report that the adduct of α -terpinene and maleic anhydride may be converted to the barium salt and decomposed by heating to recover all but 7% of the original hydrocarbon; the residue is lost as *p*-cymene. These authors suggest that this reaction be used to separate α -terpinene from other mixtures and

other terpinenes. They have pointed out also the possibilities of the acrolein addition product b_{10} 116° – 119° , d_4^{20} 0.9691, which is decomposed completely into the original substances by distillation at ordinary pressures.

Gascoigne ³ has further confirmed the usefulness of the diene synthesis as a means of separation. He observed that the α -terpinene-maleic anhydride reaction proceeds quantitatively at room temperature, and thus may be used specifically to detect and characterize this hydrocarbon.

Alder and Richert ⁴ earlier suggested the acetylene dicarboxylic acids as a general method of analysis of conjugated cyclohexadienes.

Identification.—(1) Treatment of α -terpinene with nitrous acid yields a nitrosite m. 155° . In fact, the designation α -terpinene is reserved for that terpene which gives this nitrosite. The percentage of α -terpinene present in a mixture can be estimated approximately by the yield of the nitrosite which, however, may fail to form if the percentage of α -terpinene is low, or in mixtures with γ -terpinene. In such cases, the presence of α -terpinene can be proved by oxidation (see below), as the substituted adipic acid may be isolated and readily identified.

Modifying the procedure of Wallach,⁵ the nitrosite can be prepared as follows:

Mix 3 cc. of the corresponding hydrocarbon fraction b. 175° – 185° with 1.5 cc. of glacial acetic acid and 4.5 cc. of water. Add to this mixture a concentrated aqueous solution of 1.5 g. of sodium nitrite in small portions and at a low temperature. A reddish-yellow color will appear when the nitrous acid has been completely absorbed. Inoculate with a small crystal of pure nitrosite. Wash the crystals, which separate after a short time, with petroleum ether and water, and finally recrystallize from alcohol.

Treatment of the terpinene nitrosite with bases such as piperidine and benzylamine yields nitrolamines: nitrolpiperidine m. 153° – 154° , nitrolbenzylamine m. 137° . The benzoyl derivative of the nitrosite melts at 77° – 78° .

(2) A positive method of distinguishing α -terpinene from γ -terpinene is by oxidation with potassium permanganate to α,α' -dihydroxy- α -methyl- α' -isopropyladipic acid m. 188° – 189° . The lactone of this acid melts at 72° – 73° . Wallach ⁶ suggested the following procedure:

Place a mixture of 7 g. of the hydrocarbon, 33 g. of potassium permanganate, 14 g. of potassium hydroxide, 400 g. of ice, and 400 cc. of water in a copper flask and shake on a machine for an hour. Distill off the excess of hydrocarbon, separate the manganese oxide by filtration, and saturate the filtrate with carbon dioxide while it is being evaporated to dryness. Extract the residue with alcohol, evaporate the alcoholic filtrate to dryness, dissolve this residue with a small quantity of hot water, and set the solution aside for crystallization. Separate the crystalline mass, wash with a little cold water, dry on porous plates, and recrystallize from 15 to 20 times its weight of 25% alcohol. The erythritol $C_{10}H_{16}(OH)_4$ thus formed by the oxidation of γ -terpinene melts at 235° – 236° , or at 237° – 238° if heated rapidly. The erythritol is sparingly soluble in ether, ligroine, ethyl acetate and chloroform; not readily soluble in cold alcohol or water, but more readily in hot alcohol or water. In order to identify α -terpinene, the mother liquor from the erythritol is extracted with ethyl acetate and supersaturated with sulfuric acid at low temperature. Extract this acid liquid once with ether and exhaust it by extracting with ethyl acetate. This will take up an acid which crystallizes on proper concentration of the solvent. After recrystallization from about 6 times its own weight of water, the α,α' -dihydroxy- α -methyl- α' -isopropyladipic acid will melt at 189° with elimination of water.

Recently Diels, Koch and Frost ⁷ questioned this oxidative step with potassium permanganate as a method of structure proof for α -terpinene, and attempted the use of the diene synthesis as a corroborative reaction. However, they found the action with maleic anhydride complex and, according to Alder,⁸ unnecessary.

A characteristic of α -terpinene which distinguishes it from γ -terpinene is the fact that, upon oxidation with Beckmann's chromic acid reagent, brown resinous flakes separate immediately, whereas with γ -terpinene this is a delayed reaction. This feature was first observed by Baeyer⁹ and later confirmed by Richter and Wolff.¹⁰ The capability of complete oxidation in the cold with Beckmann's chromic acid mixture may be used to remove terpinene from a mixture with pinene, camphene, limonene, terpinolene, cineole, and pinol, as these compounds are quite resistant against the action of Beckmann's chromic acid mixture in the cold.

Elson, Gibson and Simonsen¹¹ obtained 1,4-oxido- Δ^2 -*p*-menthene and 30% *p*-cymene by action of benzoyl hydroperoxide on α -terpinene.

(3) With halogen acids α -terpinene, according to Wallach,¹² readily forms crystalline derivatives:

Dihydrochloride	m. 51°–52°
Dihydrobromide	m. 58°–59°
Dihydroiodide	m. 76°

These melting points are somewhat higher than those of the corresponding dipentene derivatives.

(4) The adduct with maleic anhydride should be a characteristic derivative; this is true also of the derived acid compounds. However, the variant properties thus far reported suggest that the nature of starting products remains questionable. (Littman,¹³ Diels, Koch and Frost,¹⁴ Sfiras,¹⁵ Goodway and West,¹⁶ Gascoigne,¹⁷ Briggs and Sutherland,¹⁸ and Ipatieff and Pines.¹⁹)

	<i>Adduct with Maleic Anhydride</i>	<i>Derived Dicarboxylic Acids</i>
m.	60°–61° ¹⁷	158° (<i>cis</i>) ¹⁴ 203° (<i>trans</i>) ¹⁴
	61°–62° ¹⁸	147°–148° ¹⁸
	62° ¹⁶	134° ¹⁶
	64°–65° ¹⁹	127°–128° ¹⁹
	65°–66° ¹⁵	
	66°–67° ¹⁴	
b ₁₂	195° ¹⁴	
b ₅	155°–165° ¹⁸	
b ₁	152°–154° ¹³	
d ₄ ⁶⁷	1.100 ¹³	
n _D ⁶⁷	1.4913 ¹³	

(5) An addition compound with benzoquinone in alcohol is formed in 2 hr. Gascoigne²⁰ reports m. 87°–88°.

Properties.— α -Terpinene is a colorless oil possessing a somewhat lemon-like odor. As stated, α -terpinene has probably never been obtained in absolutely pure form, as it always contains at least a small portion of the γ -isomer. Thus, the observed properties of α -terpinene have naturally varied.

Wallach²¹ reported these properties:

b.	174°–179° and 179°–181°
d ₂₂	0.842
d ₂₀	0.846
n _D	1.4719 and 1.4789

Schimmel & Co.²² found the following properties for a fraction of coriander oil, consisting of α - and γ -terpinene:

b.	177°–178°
d_{15}^{15}	0.8485
n_D^{20}	1.47650

Auwers²³ recorded for a carefully prepared α -terpinene:

b.	180°–182°
d_4^{15}	0.8484
$n_D^{15.6}$	1.48133

Richter and Wolff²⁴ prepared α -terpinene by the action of aniline on terpinene dihydrochloride and found these somewhat different properties:

b_{755}	173.5°–174.8°
$d_4^{19.6}$	0.8375
$n_D^{19.7}$	1.477

α -Terpinene resembles dipentene in many ways—for example, in regard to the hydrogen halide derivatives. It polymerizes and resinifies quickly, especially when exposed to air and sunlight. α -Terpinene is easily converted into *p*-cymene—for instance, by dehydrogenation with sulfur, according to Ruzicka, Meyer and Mingazzini.²⁵

- ¹ *Liebigs Ann.* **350** (1906), 148.
² *Byull. Vsesoyuz. Khim. Obshchestva im. D. I. Mendeleeva* (1939), No. 3–4, 35. *Khim. Referat. Zhur.* (1939), No. 7, 26. *Chem. Abstracts* **34** (1940), 4386.
³ *J. Proc. Roy. Soc. N. S. Wales* **74** (1940), 353.
⁴ *Ber.* **70B** (1937), 1364.
⁵ *Liebigs Ann.* **239** (1887), 35.
⁶ *Ibid.* **362** (1908), 297. See also Henry and Paget, *J. Chem. Soc.* **123** (1923), 1878.
⁷ *Ber.* **71B** (1938), 1163.
⁸ *Ber.* **71B** (1938), 2210.
⁹ *Ber.* **27** (1894), 815.
¹⁰ *Ber.* **60** (1927), 477.
¹¹ *J. Chem. Soc.* (1929), 2732.
¹² *Liebigs Ann.* **350** (1906), 145; **356** (1907), 198.
¹³ *J. Am. Chem. Soc.* **57** (1935), 586.
¹⁴ *Ber.* **71B** (1938), 1168.
¹⁵ *Recherches* (Roure-Bertrand fils and Jules DuPont) **2**, No. 7 (1938), 111. *Chem. Abstracts* **35** (1941), 8210.
¹⁶ *J. Chem. Soc.* (1940), 702.
¹⁷ *J. Proc. Roy. Soc. N. S. Wales* **74** (1940), 363.
¹⁸ *J. Org. Chem.* **7** (1942), 402.
¹⁹ *J. Am. Chem. Soc.* **66** (1944), 1120.
²⁰ *J. Proc. Roy. Soc. N. S. Wales* **74** (1940), 357.
²¹ *Liebigs Ann.* **350** (1906), 149; **362** (1908), 301.

²² Gildemeister and Hoffmann, "Die Ätherischen Öle," 3d Ed., Vol. I, 332.

²³ *Ber.* **42** (1909), 2428.

²⁴ *Ber.* **63** (1930), 1720.

²⁵ *Helv. Chim. Acta* **5** (1922), 356.

β-Terpinene

C₁₀H₁₆

Mol. Weight 136.23

1(7),3-*p*-Menthadiene. 1-Methylene-4-isopropyl-3-cyclohexene

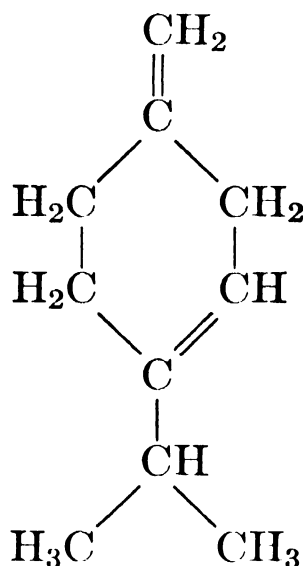

Occurrence.—This terpene has not been found in nature.

Identification.—*β*-Terpinene differs from both *α*- and *γ*-terpinene in yielding a crystalline tetrabromide which is formed on addition of bromine to a well-cooled ether-alcohol solution of the terpene. The tetrabromide crystallizes from ethyl acetate in prisms m. 154°–155°.

Properties.—Wallach¹ reported these physicochemical properties for *β*-terpinene:

b.	173°–174°
d ₂₂	0.838
n _D ²²	1.4754

The molecular refraction of *β*-terpinene, as can be expected from its constitution, shows a marked exaltation (observed 45.72, calculated 45.24).

β-Terpinene oxidizes very easily and, on exposure to air and sunlight, forms dihydrocuminaldehyde and cuminaldehyde.

¹ *Liebigs Ann.* **357** (1907), 69; **362** (1908), 288, 292.

γ -TerpineneC₁₀H₁₆

Mol. Weight 136.23

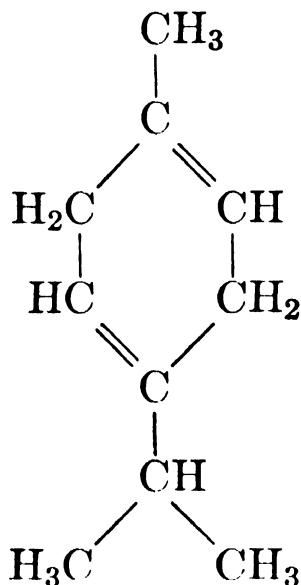
1,4-*p*-Menthadiene. 1-Methyl-4-isopropyl-1,4-cyclohexadiene

Occurrence.— γ -Terpinene forms a minor constituent of ordinary “terpinene.” (See “ α -Terpinene.”)

γ -Terpinene has been found in oil of coriander, lemon, cumin, and *Ocimum viride*. Probably free from admixture with its α - isomeride, γ -terpinene occurs in oil of ajowan, thyme, *Eucalyptus dives*,¹ *Crithmum maritimum* (oil of samphire or seafennel), and *Mosla japonica*.

When first observed in the two last-named oils, γ -terpinene was not identified as such, but was mistaken for other terpenes, and named crithmene and moslene, respectively. However, Richter and Wolff² proved conclusively that both *crithmene* and *moslene* are identical with γ -terpinene. Richter and Wolff also showed that the terpene fraction from ajowan oil, commercially known as “thymene,” consists mainly of γ -terpinene.

This hydrocarbon is reported to predominate in the earlier stages of development in *Trachyspermum copticum*,³ and a small percentage has recently been identified in orthodon oils,⁴ and those from *Cupressus macrocarpa*.⁵

Isolation.—By fractional distillation.

Identification.—(1) According to Richter and Wolff,⁶ γ -terpinene may be characterized by the preparation of a nitrosate m. 116°, a nitrosochloride m. 111°, a nitrolpiperidine m. 149°, a crystalline tetrabromide m. 128°, a dihydrochloride m. 52°.

(2) In the presence of other terpenes, especially α -terpinene, γ -terpinene can be identified more definitely by the oxidation with potassium permanganate to the erythritol C₁₀H₁₆(OH)₄, *p*-menthantetrol (1,2,4,5), m. 237°–238°, according to Wallach⁷ (see “ α -Terpinene”). In case γ -terpinene is present in quantity, the identification through the nitrosate or nitrosochloride should prove more convenient.

Most of these derivatives have been confirmed in the recent work of Briggs and Sutherland.⁸

Properties.— γ -Terpinene has not yet been obtained in absolutely pure form.

Richter and Wolff⁹ reported these properties for a characteristic γ -terpinene isolated from "thymene":

b.	183°	d_4^{20}	0.849
b_{18}	72.5°	d_4^{15}	0.853
		$n_D^{14.5}$	1.4765

γ -Terpinene oxidizes very easily on exposure to air, with accompanying liberation of hydrogen peroxide and formation of *p*-cymene.

Beckmann's chromic acid solution reacts upon γ -terpinene only slowly, thus differentiating it from its α - isomer.

¹ *Ber. Schimmel & Co.* (1930), 42.

² *Ber.* **60** (1927), 477; **63** (1930), 1714.

³ Nilov, *Bull. App. Bot. Genetic Plant Breeding, U.S.S.R.*, Ser. II, No. 13 (1936), 5. *Chem. Abstracts* **31** (1937), 3102.

⁴ Huzita, *J. Chem. Soc. Japan* **61** (1940), 729. *Chem. Abstracts* **36** (1942), 6753.

⁵ Briggs and Sutherland, *J. Organic Chem.* **7** (1942), 397.

⁶ *Ber.* **60** (1927), 477; **63** (1930), 1719.

⁷ *Liebigs Ann.* **362** (1908), 297.

⁸ *J. Organic Chem.* **7** (1942), 397.

⁹ *Ber.* **63** (1930), 1714.

α -Phellandrene

$C_{10}H_{16}$

Mol. Weight 136.23

1,5-*p*-Menthadiene. 1-Methyl-4-isopropyl-1,5-cyclohexadiene

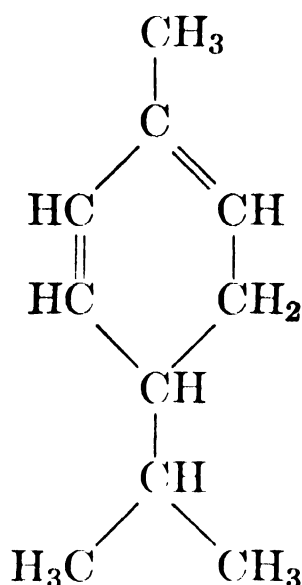

Occurrence.—*d*- α -Phellandrene occurs in oil of cinnamon, gingergrass, Manila elemi, bitter fennel, *Schinus mollé*, Spanish dill herb (wild growing), etc.

Its optical enantiomorph *l*- α -phellandrene has been found in oil of *Eucalyptus dives*, *E. phellandra*, star anise, pimento, bay, pepper, etc.

Isolation.—A fraction containing principally α -phellandrene may be isolated from essential oils—for example, from *Eucalyptus dives* oil—by fractional distillation *in*

vacuo. The fractions so obtained are most often contaminated with closely related isomers whose removal is not readily effected by distillation. Thus it seems unlikely that absolutely pure α -phellandrene has so far been isolated from essential oils. A crystalline derivative from which this terpene may be regenerated unchanged is as yet unknown. Moreover, the nitrosites, ordinarily used in the past to characterize α -phellandrene, have been shown to have dubious value as criteria of purity.

Identification.—Wallach and Gildemeister¹ developed a rapid test for determining the presence of phellandrene:

Dissolve 5 cc. of the oil or of the fraction in question in 10 cc. of petroleum ether. At the same time, prepare a solution of 5 g. of sodium nitrite in 8 cc. of water. Carefully layer the second solution beneath the first one in a test tube, and add gradually with shaking the quantity (5 cc.) of glacial acetic acid necessary for the development of nitrous acid. Under suction, filter off the precipitated voluminous crystalline mass consisting of a mixture of both α - and β -nitrosites, wash first with water, then with methyl alcohol, and finally purify by repeatedly dissolving in chloroform and precipitating with methyl alcohol. However, by this method the most soluble of the nitrosites is lost.

Modified methods for detecting the presence of phellandrene, by the nitrosite formation, have also been offered by Baker and Smith,² Smith, Hurst and Read,³ and the U.S.P. XIII (p. 217). All of these tests, however, are concerned merely with the demonstration of the presence or absence of nitrosite crystals, not with the separation and characterization of the α - and β - forms of the nitrosite.

Wallach⁴ himself suggested a method of differential separation of these isomers by means of acetone and water. Smith, Carter and Read⁵ also developed a technique of distinguishing these α - and β -nitrosites by taking advantage of their marked difference in solubility in carbon bisulfide. It is, however, only recently that the proper procedure for isolation of the untransformed α - and β - forms has been published by Berry, Macbeth and Swanson.⁶ This method is based upon the fact that the β - form is thermo-sensitive.

The α - and β -nitrosites of α -phellandrene were early described by Schreiner,⁷ and Wallach.⁸ Read⁹ and collaborators studied their preparation and mutarotatory characteristics in some detail. It remained, however, for Berry et al.¹⁰ to show that the β - compound is sufficiently labile to undergo transmutation into the α - compound, under conditions ordinarily used for purification in the past. From these investigations, it appears that the properties of the nitrosites of *d*- and *l*- α -phellandrene, isolated under conditions of maximum stability and purity, are:

	<i>d</i> - α		<i>l</i> - α	
	(α)	(β)	(α)	(β)
m.	119° 10	100° 10	120°–121° 9	96° 10
$[\alpha]_D^{20}$	–133° 48' 10	+211° 10	+142° 36' 8,9	–260° 6' 10
in CHCl ₃	(c = 1.265)	(c = 1.15)	(c = 1.25) *	(c = 1.25)

$[\alpha]_D^{20}$ for *d*- and *l*- α -Phellandrene- α -nitrosites
in Different Solvents

	$\overbrace{d-\alpha}^{10}$	$\overbrace{l-\alpha}^{9,10}$
Chloroform	–133° 48' (c = 1.265)	+142° 36' (c = 1.25) +141° 36' (c = 1.264)
Acetone	–168° 24' (c = 1.253)	+165° 54' (c = 1.25) +175° 36' (c = 1.247)
Benzene	–217° (c = 1.255)	+234° 24' (c = 1.25) +240° 48' (c = 1.171)

* Wallach reported $[\alpha]_D^{19}$ + 142° 36' (c = 12.2, chloroform).

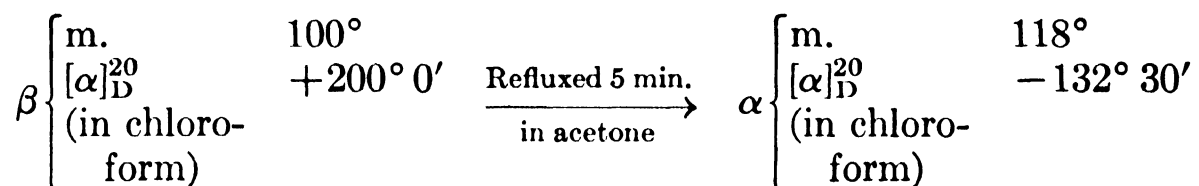
*Transmutation of d- α -Phellandrene- β -nitrosite into - α -nitrosite*¹⁰

Read and Storey¹¹ (1930) reported the melting point of α -nitrosite of *dl*- α -phellandrene as 113°. Carter¹² (1926) writes "the α - and β -nitrosite of *dl*- α -phellandrene have melting points almost identical with those of the respective nitrosites derived from the optically active forms of α -phellandrene." One may thus conclude that $\sim 113^\circ$ and $\sim 105^\circ$ are the melting points to be assigned to these derivatives. It should not be overlooked, however, that these findings precede the observation of Berry and co-workers¹³ (1939) regarding the lability of the β -form.

Unlike terpinene nitrosite, the phellandrene nitrosites cannot be converted, with bases, to nitrolamines. When treated with sodium alcoholate, α -phellandrene nitrosite yields nitro- α -phellandrene which, by reduction with zinc and glacial acetic acid, gives carvotanacetone and dihydrocarvylamine. Wallach and Lauffer¹⁴ showed that both nitrosites are bimolecular.

A new method for identifying α -phellandrene by means of its maleic anhydride adduct has been developed in the last few years. Diels and Alder¹⁵ first prepared this addition compound (m. 126°–127°) from the active isomers. Birch¹⁶ utilized this reaction to develop a neat method for the determination of relative amounts of *d*- and *l*-isomers as well as to establish the presence of the racemic form by means of mixed melting points of the adduct.

	<i>l</i>	<i>dl</i>					<i>d</i>
% <i>d</i>	0	20	40	50	60	80	100
% <i>l</i>	100	80	60	50	40	20	0
m. °	127	113	100	93	100	113	127

Kaufman, Baltés and Josephs,¹⁷ and Goodway and West¹⁸ describe the determination of the "diene number" for the phellandrenes, which may be a most useful index of purity, as it has been found that this figure and the optical rotation are linear variants.¹⁹

Goodway and West²⁰ also determined the proper conditions under which only the α -phellandrenes would react with maleic anhydride while the β -compound would not; they were thus able to prepare separative derivatives for this terpene. These authors recommend:

Reflux 10 g. of *l*- α -phellandrene with 5 g. of maleic anhydride in 20 cc. of ether for 30 min. Recrystallize the adduct from methyl alcohol, m. 126°, $[\alpha]_D^{25} -8^\circ 54'$ in CHCl_3 ($c = 12.59$).

The *d*- α -compound is prepared in the same way, m. 126°, $[\alpha]_D^{22} +9^\circ 24'$ in CHCl_3 ($c = 8.655$).

The racemic mixture melts at 91°–94°.

A characteristic gold complex m. 158°–163° has been prepared by Nakatsuchi²¹ from the sulfur derivative of α -phellandrene.

Fawsitt²² developed an empirical equation in terms of specific constants for mixtures of cineole, pinene, and *l*- α -phellandrene that may be useful in analyzing mixtures of these components where they are known to occur as impurities in a solution with *l*- α -phellandrene.

Where β -phellandrene may be a contaminant, and for purposes of removing this

isomer from a phellandrene system, West ²³ recommends a method for preparation of the nitrosochloride wherein the α -phellandrene does not form; the conditions are:

Dissolve the mixture in methyl alcohol and ethyl nitrite, cool to -5°C ., add dropwise, over a period of 40 min., a well-cooled mixture of 5N HCl in methyl alcohol. The nitrosochloride of β -phellandrene forms under these conditions and may be removed.

A compound of the formula $\text{C}_{20}\text{H}_{20}\text{O}$, m. 139° – 140° , unique to α -phellandrene, has been prepared by Salfeld ²⁴ who condensed β -naphthol with this terpene. This condensate yields a characteristic *p*-nitrobenzoate m. 164° – 165° .

Properties.— α -Phellandrene is a colorless mobile oil possessing a somewhat peculiar, but not unpleasant, odor.

As pointed out, α -phellandrene has been observed in the dextro- and laevo-rotatory, and also in the optically inactive forms. Gildemeister and Hoffmann ²⁵ recorded the following properties for *l*- α - and *d*- α -phellandrene:

l- α -Phellandrene (from oil of *Eucalyptus amygdalina* and *E. dives*)

b_{754}	173° – 175°	$[\alpha]_{\text{D}}^{20}$	$-112^{\circ} 46'$
b_{22}	67° – 68°	$[\alpha]_{\text{D}}^{15}$	$-140^{\circ} 25'$ ²⁶
b_5	50° – 52°	n_{D}^{25}	1.4725
d_4^{20}	0.8425	n_{D}^{20}	1.4769
d_{15}^{15}	0.8480		

These characteristics were, in a large measure, confirmed in the work of Smith, Hurst and Read ²⁷ on a very carefully purified *l*- α -phellandrene obtained from *Eucalyptus dives* oil.

A sample of this type of oil was exhaustively fractionated by Hancox and Jones ²⁸ to obtain an optically pure product for which they report:

d_{20}	0.8324	n_{D}^{20}	1.4724
$[\alpha]_{\text{D}}^{20}$	$-177^{\circ} 24'$	Diene No. found	186.3
		Diene No. calc.	186.6

d- α -Phellandrene (from oil of gingergrass and elemi) as reported by Gildemeister and Hoffmann does not seem to have been obtained in as high a state of purity as *l*- α -phellandrene.

b_{754}	175° – 176°	d_{19}	0.844
b_{11}	61°	d_{15}^{15}	0.8565, 0.847 ²⁹
b_4	44° – 45°	$[\alpha]_{\text{D}}^{15}$	$+115^{\circ} 0'$ ²⁹
		n_{D}^{19}	1.4732

dl- α -Phellandrene is described by Wallach, ³⁰ and by Read and Storey ³¹ as follows:

$b.$	175° – 176° ³⁰	d_{22}	0.841 ³⁰
$b_{15.5}$	63° – 65° ³¹	n_{D}^{22}	1.4760 ³⁰
		$n_{\text{D}}^{19.5}$	1.4772 ³¹

The molecular refraction of α -phellandrene shows little exaltation (observed 45.61, calculated 45.24), which quality tends to confirm the accepted constitution of this terpene.

Phellandrene is a rather unstable compound, except when stored under conditions that exclude air and light. It polymerizes and resinifies readily, especially when heated to its boiling point at atmospheric pressure. On exposure to air its rotatory power diminishes rapidly. With acids, phellandrene is converted into optically inactive isomers; with hydrogen halides into dipentene; with alcoholic sulfuric acid into terpinene.

Investigating the terpenes contained in oil of *Eucalyptus cneorifolia*, Berry³² observed that on treatment with bromine α -phellandrene formed a heavily brominated mixture of unknown composition, but containing considerably more bromine than was required to form the dibromide. Simultaneously cymene was formed, together with large amounts of hydrogen bromide, the latter accounting for about 25 per cent of the bromine used.

Use.— α -Phellandrene is used in scents which serve to overcome objectionable odors in technical products. It is also employed for the compounding of artificial essential oils or oil imitations.

- ¹ *Liebigs Ann.* **246** (1888), 282.
- ² "A Research on the Eucalypts," 2d Ed., Sydney (1920), 413.
- ³ *J. Chem. Soc.* **123** (1923), 1657.
- ⁴ *Liebigs Ann.* **336** (1904), 13.
- ⁵ *J. Chem. Soc.* **125** (1924), 930.
- ⁶ *Ibid.* (1939), 466, 1418.
- ⁷ *Pharm. Arch.* **4** (1901), 90. *Ber. Schimmel & Co.*, April (1901), 66.
- ⁸ *Liebigs Ann.* **336** (1904), 9.
- ⁹ *J. Chem. Soc.* **123** (1923), 1657 (Smith, Hurst and Read). *Ibid.* **125** (1924), 930 (Smith, Carter and Read).
- ¹⁰ *J. Chem. Soc.* (1939), 466, 1418 (Berry, Macbeth and Swanson).
- ¹¹ *J. Chem. Soc.* (1930), 2781.
- ¹² Dissertation St. Andrews (1926).
- ¹³ *J. Chem. Soc.* (1939), 466, 1418.
- ¹⁴ *Liebigs Ann.* **287** (1895), 384; **313** (1900), 345.
- ¹⁵ *Liebigs Ann.* **460** (1928), 98.
- ¹⁶ *J. Proc. Roy. Soc. N. S. Wales* **71** (1937), 54; **71** (1938), 261.
- ¹⁷ *Ber.* **70** (1937), 908.
- ¹⁸ *J. Soc. Chem. Ind.* **57** (1938), 37T.
- ¹⁹ Hancox and Jones, *Univ. Queensland Papers*, Dept. Chem. **1**, No. 14 (1939). *Proc. Roy. Soc. Queensland* **50** (1938), 14.
- ²⁰ *J. Soc. Chem. Ind.* **56** (1937), 472T.
- ²¹ *J. Soc. Chem. Ind. Japan* **38** (1935), Suppl. bind. 617. *Chem. Abstracts* **30** (1936), 1372.
- ²² *J. Chem. Soc.* **115** (1919), 790.
- ²³ *J. Soc. Chem. Ind.* **58** (1939), 122T.
- ²⁴ *Ber.* **73** (1940), 382.
- ²⁵ "Die Ätherischen Öle," 3d Ed., Vol. I, 338.
- ²⁶ *Ber. Schimmel & Co.* (1930), 165.
- ²⁷ *J. Chem. Soc.* **123** (1923), 1657.
- ²⁸ *Univ. Queensland Papers*, Dept. Chem. **1**, No. 14 (1939). *Proc. Roy. Soc. Queensland* **50** (1939), 14.
- ²⁹ *Ber. Schimmel & Co.* (1930), 165.
- ³⁰ *Liebigs Ann.* **359** (1908), 283. ³¹ *J. Chem. Soc.* (1930), 2781.
- ³² *Australian Chem. Inst. J. and Proc.* **14** (1947), 373.

β -Phellandrene $C_{10}H_{16}$

Mol. Weight 136.23

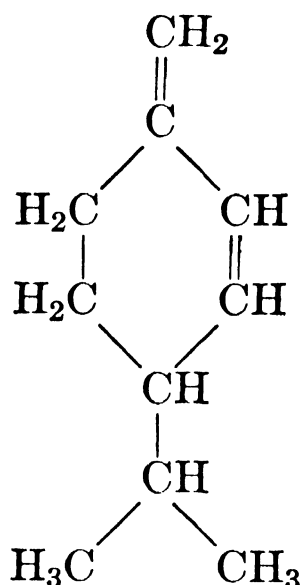
1(7),2-*p*-Menthadiene. 1-Methylene-4-isopropyl-2-cyclohexene

Occurrence.—Like α -phellandrene, β -phellandrene occurs in dextro- and laevorotatory form: *d*- β -phellandrene in oil of star anise, water fennel, angelica, African ginger, etc.; *l*- β -phellandrene in Japanese pepper oil, in the turpentine oil of *Pinus contorta*, Canada balsam, etc.

β -Phellandrene of unknown rotation has been observed in oil of lemon, Seychelles cinnamon, *Schinus mollé* L., *Eucalyptus amygdalina*, and Italian seafennel; it may occur also in coriander and cumin oil, etc.

Isolation.—By fractional distillation *in vacuo*.

Identification.— β -Phellandrene may be characterized by the preparation of various derivatives:

(1) The nitrosites occur in two (α - and β -) crystalline forms and may be prepared according to the method described under α -phellandrene. Investigating the nitrosite reaction of β -phellandrene, Gaponenkov¹ obtained the best yields in the cold, with petroleum ether and ether (1 + 1) as solvent, and without an excess of glacial acetic acid. Thus, 2.0 g. of β -phellandrene dissolved in 4.0 cc. of the petroleum ether-ether mixture, and treated with 2.0 g. of sodium nitrite in 4.0 cc. of water and 1.65 cc. of glacial acetic acid, after cooling to -10° , yielded 0.95 g. of nitrosite.

β -Phellandrene- α -nitrosite m. 102° , $[\alpha]_D^{18.5} -159^\circ 18'$ (in chloroform solution).
 β -Phellandrene- β -nitrosite m. 97° – 98° , optically almost inactive.

Berry, Macbeth and Swanson² reported that, unlike the mutarotation of α -phellandrene nitrosite, that of *d*- β -phellandrene- α -nitrosite is not wide. Similar observations were made by Smith and West³ who reported for *l*- β -phellandrene-nitrosite (3.85% sol. in $CHCl_3$) an original rotation of $+157^\circ 54'$; after one day $+110^\circ$; after three days $+83^\circ$; and after four days $+60^\circ$.

When treating either the α - or β -nitrosite of β -phellandrene with sodium ethylate at 30° – 40° , Wallach⁴ obtained nitro- β -phellandrene. This on reduction with zinc dust in glacial acetic acid solution yielded the nitro compound of dihydrocumaldehyde and dihydrocuminyamine, whereas reduction with sodium and alcohol gave tetrahydrocuminyamine and cuminyamine.

(2) According to Francesconi and Sernagiotto,⁵ β -phellandrene, on treatment with ethyl nitrite in alcoholic solution and in presence of alcoholic hydrochloride, gives a nitrosochloride, the yield percentage of which is inverse to the rotatory power of the terpene. By fractional crystallization the nitrosochloride, $\alpha_D -206^\circ 0'$, can be separated into two isomers:

α -nitrosochloride	m. 101° – 102° , $\alpha_D -175^\circ 0'$;
β -nitrosochloride	m. 100° , $\alpha_D -285^\circ 0'$.

The discovery of the nitrosochloride has provided a valuable method for distinguishing between α - and β -phellandrene, the former yielding a liquid nitrosochloride; the latter, crystalline compounds as described above. West⁶ was able to use this derivative to differentiate between the α - and β - forms. This author reported that β -phellandrene, methyl alcohol, and ethyl nitrite mixed and cooled below -5° and a 5 normal solution of hydrochloric acid in methyl alcohol, added dropwise with constant stirring, yielded a crystalline nitrosochloride, whereas no crystalline material could be obtained under the same conditions from α -phellandrene.

(3) According to Wallach,⁷ β -phellandrene on oxidation with a 1% potassium permanganate solution at 0° yields a viscid glycol $b_{10} 150^\circ$. When heated with dilute sulfuric acid, the glycol gives dihydrocumin alcohol and tetrahydrocumaldehyde (phellandral). This aldehyde may be identified by the preparation of its semicarbazone m. 204° – 205° .

(4) According to Goodway and West,⁸ the Kaufman method may be employed to characterize the phellandrenes which yield a particular diene value when heated in a sealed tube with maleic anhydride dissolved in toluene, followed by addition of potassium iodide and potassium iodate, and titration of the liberated iodine with sodium thiosulfate.

(5) The active tetrabromides, according to Berry and Macbeth.⁹

l- β -Phellandrene yields *d*-tetrabromide (recrystallized from ethyl alcohol):

$$\text{m. } 118^\circ\text{--}119^\circ, [\alpha] +54^\circ \text{ (in ethyl acetate)}$$

d- β -Phellandrene yields *l*-tetrabromide:

$$\text{m. } 118^\circ\text{--}119^\circ, [\alpha] -53^\circ.$$

Properties.— β -Phellandrene is a liquid possessing a peculiar, but not disagreeable, odor. Wallach¹⁰ and Pesci¹¹ reported the following properties for the *d*- modification:

b_{766}	171° – 172° ¹¹	$[\alpha]_D$	$+14^\circ 45'$ to $+18^\circ 32'$ ¹⁰
b_{11}	57° ¹⁰	$[\alpha]_D$	$+17^\circ 38'$ ¹¹
d_{20}	0.8520 ¹⁰	n_D^{20}	1.4788 ¹⁰
d_{18}	0.848 ¹⁰	n_D^{18}	1.4759 ¹⁰
d_{10}	0.8558 ¹¹		

Francesconi and Sernagiotto¹² expressed the opinion that pure β -phellandrene has an optical rotation of about $\alpha_D + 65^\circ 0'$, the much lower values usually reported being caused by admixture of *dl*- β -phellandrene.

Smith and West¹³ reported *l*- β -phellandrene derived from Canada balsam oil as having the following properties:

b_{758}	178°–179°	$[\alpha]_D^{20}$	–50° 36'
b_{24}	78°	n_D^{20}	1.480
d_{15}^{15}	0.8497		

Berry,¹⁴ investigating the terpenes contained in the oil of *Eucalyptus neo-rifolia*, debrominated the tetrabromide of β -phellandrene and prepared this terpene in a state of purity higher than previously obtained:

b.	172°–174°		
$d_{15.5}^{15.5}$	0.843		
$[\alpha]_D^{20}$	–74° 24'		
n_D^{20}	1.4826		
	46.3	} Obs. Calc. This marked exalta- tion was to be expected.	
Mol. refr.	45.24		

The nitrosochloride m. 109° exhibited mutarotation.

On distillation under atmospheric pressure, the β -phellandrene underwent polymerization which was accompanied by inversion of the optical activity.

β -Phellandrene is quite unstable; on prolonged boiling and even on distilling at atmospheric pressure, it polymerizes to diphellandrene. On aerobic oxidation in the presence of sunlight, β -phellandrene gives 4-isopropyl-2-cyclohexen-1-one. When acted upon with hydrogen chloride in alcoholic solution, β -phellandrene, according to Francesconi and Sernagiotto,¹⁵ is converted into terpinene dihydrochloride.

Use.—Not being easily available, β -phellandrene is rarely used in the perfume and flavor industry.

¹ *J. Gen. Chem. U.S.S.R.* **5** (1935), 1485. *Chem. Abstracts* **30** (1936), 3587.

² *J. Chem. Soc.* (1937), 1448.

³ *J. Soc. Chem. Ind.* **56** (1937), 300.

⁴ *Liebigs Ann.* **336** (1904), 44; **340** (1905), 1; **343** (1905), 39.

⁵ *Gazz. chim. ital.* **46**, I (1916), 119.

⁶ *J. Soc. Chem. Ind.* **58** (1939), 122T.

⁷ *Liebigs Ann.* **340** (1905), 12.

⁸ *J. Soc. Chem. Ind.* **57** (1938), 38T.

⁹ *Nature* **156**, No. 3954 (1945), 175.

¹⁰ *Liebigs Ann.* **340** (1905), 2; **336** (1904), 43.

¹¹ *Gazz. chim. ital.* **16** (1886), 225.

¹² *Ibid.* [2], **44** (1914), 456; **46**, I (1916), 119.

¹³ *J. Soc. Chem. Ind.* **56** (1937), 300T.

¹⁴ *Australian Chem. Inst. J. and Proc.* **14** (1947), 388.

¹⁵ *Gazz. chim. ital.* **44**, II (1914), 456; **46**, I (1916), 119.

SUGGESTED ADDITIONAL LITERATURE

P. A. Berry and A. K. Macbeth, " β -Phellandrene Tetrabromide," *J. Chem. Soc.* (1947), 1039.

(b) BICYCLIC TERPENES.

Introduction.—This group of hydrocarbons comprises some of the most important terpenes—for example, α - and β -pinene. The bicyclic monoterpenes have a tendency to undergo molecular rearrangement; shifting of the double bonds may take place; oxidation, dehydrogenation, and hydrogenation occur quite readily; treatment with acid may open the rings. α - and β -Pinene may thus pass, by ring fission, into dipentene and, by molecular rearrangement, into borneol.

$C_{10}H_{16}$ Δ^3 -Carene Mol. Weight 136.23
Isodiprene

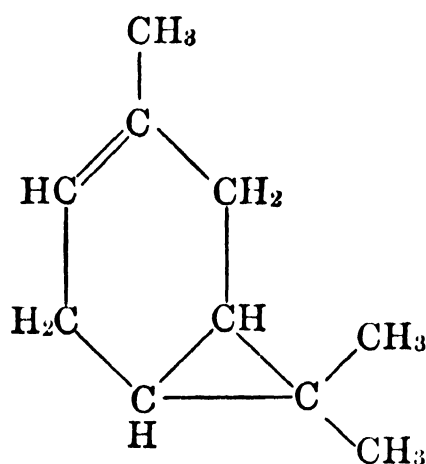

Occurrence.—The investigations of Simonsen and collaborators¹ have shown that Indian turpentine oil (*Pinus longifolia* Roxb.) does not contain *d*-sylvestrene, as formerly believed, but a bicyclic hydrocarbon, *d*- Δ^3 -carene, which, when treated with hydrogen chloride, yields a mixture of *d*-sylvestrene dihydrochloride and dipentene dihydrochloride. Later Joffre² contributed further to this information by the report that Δ^3 -carene not only constitutes 38 per cent of Indian oil of turpentine from *Pinus longifolia* but that it is a mixture of α - and β - isomers with the following formulas:

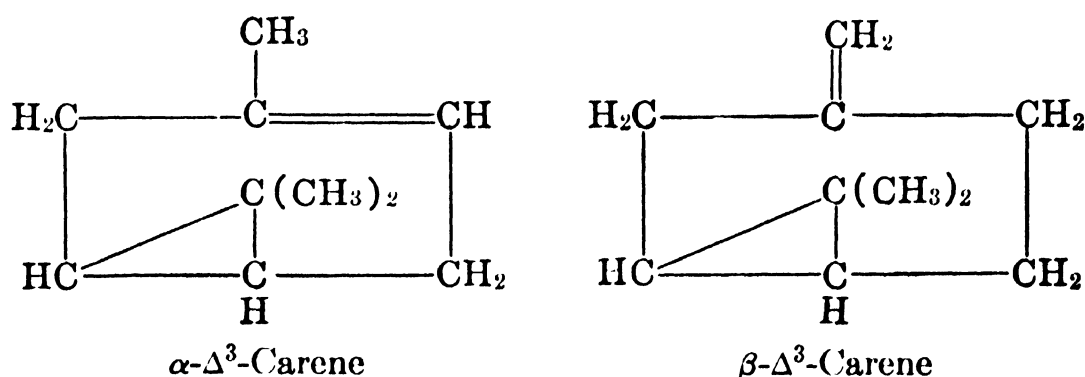

(See "Sylvestrene")

d- Δ^3 -Carene has been identified in many volatile oils—for instance, in Swedish and Finnish turpentine oils, in German pine needle oils such as *Pinus pumilio*, *P. sylvestris*, etc.

l- Δ^3 -Carene has been identified in galanga root oil (*Kaempferia galanga*), in oil of *Pinus sylvestris*, and other *pinus* oils.

The 5,6-epoxide of the *l*- isomer has been recognized in oil from *Zieria smithii*.³

Isolation.—By fractional distillation.

Identification.— Δ^3 -Carene may be identified by the following means:

(1) The preparation of the sparingly soluble carene nitrosate m. 147.5° (with decomposition). This compound readily forms and separates even if Δ^3 -carene is present only in small quantities.

(2) Its nitrosochloride m. 101°–102° (with decomposition). Lagache⁴ suggested that the nitrosochloride be prepared by adding, drop by drop, 4 to 5 cc. of hydrochloric acid to a cooled (+5°) mixture of 5 cc. of carene, 5 cc. of acetic acid, 5 cc. of 95% alcohol, and 10 cc. of ethylnitrite. The very instable nitrosochloride will separate after 1 to 2 hr. The nitrosochloride can be further characterized by the preparation of the nitrolmethyamine m. 180°, the nitroethylamine m. 155°, and the nitrolaniline m. 143°–144°. When heated on the steam bath with sodium carbonate and 95% alcohol, the nitrosochloride is converted into nitrosocarene m. 89°–90°.

(3) A characteristic adduct has been prepared by Diels, Koch and Frost,⁵ with maleic anhydride in the ratio of 1:1 of the hydrocarbon and acid anhydride. The boiling point recorded by these authors at 10 mm. is 195° and the derived dicarboxylic acid has a melting point of 184°. Hultsch⁶ reported a maleic anhydride addition product of m. 183° and formula C₁₄H₂₀O₄. Goodway and West⁷ point out, however, that addition products at variance with these findings may be due to differences in the isomeric nature of the products investigated by different workers.

Properties.— Δ^3 -Carene is a colorless oil possessing a peculiar, sweet odor. Simonsen,⁸ Lagache,⁹ Dupont,¹⁰ and Panicker, Rao and Simonsen¹¹ reported these characteristic properties:

	<i>d</i> - Isomer	<i>l</i> - Isomer
b.	170° ¹⁰	
b ₇₀₅	168°–169° ⁸	
b ₆₈₅		166°–167° ¹¹
b ₂₀₀	123°–124° ⁸	
b ₁₀	70° ¹⁰	
d ₃₀ ³⁰	0.8586 ⁸	0.8606 ¹¹
d ₂₅	0.8635 ⁹	
d ₁₅	0.8668 ¹⁰	
α_D	+7° 41' ⁸	
$[\alpha]_{578}$	+17° 6' ⁹	
$[\alpha]_D^{30}$		–5° 43' ¹¹
n _D ³⁰	1.469 ⁸	1.4684 ¹¹
n _D ²⁵	1.4678 ⁹	

Δ^3 -Carene oxidizes with remarkable ease and resinifies quite rapidly on exposure to air.¹² Oxidation may be inhibited, at least for a time, by the addition of a trace of pyrogallol.

According to Simonsen and Rau,¹³ oxidation of Δ^3 -carene with potassium permanganate in acetone solution or with Beckmann's chromic acid mixture yields a complex mixture of acids, among them *cis*- and *trans*-caronic acids m. 174°–175° (with decomposition) and 213°, respectively, and a dibasic acid C₈H₁₂O₄, viz., *cis*-homocaronic acid m. 136°–137°.

When treated with anhydrous hydrogen chloride, Δ^3 -carene yields sylvestrene dihydrochloride, but when treated with aqueous hydrochloric acid, Δ^3 -carene gives dipentene dihydrochloride.

Use.—Due to the difficulty of preparing quantities of Δ^3 -carene, this terpene, as such, has not found any noteworthy use.

¹ *J. Chem. Soc.* **117** (1920), 570; **121** (1922), 2292; **123** (1923), 549; **127** (1925), 2494; (1928), 359; (1929), 305.

² *Bull. inst. pin* [2], **13** (1931), 79.

³ Penfold, Ramage and Simonsen, *J. Chem. Soc.* (1939), 1496.

⁴ *Bull. inst. pin* (1927), 233, 255.

⁵ *Ber.* **71B** (1938), 1163.

⁶ *Ber.* **72B** (1939), 1173.

⁷ *J. Chem. Soc.* (1940), 702.

⁸ *Ibid.* **117** (1920), 570; **127** (1925), 2494.

⁹ *Bull. inst. pin* (1927), 233.

¹⁰ *Ann. chim.* [10], **1** (1924), 268.

¹¹ *J. Indian Inst. Sci.* [A], **9** (1926), 137. *Chem. Zentr.* I (1927), 653.

¹² See also Owen and Simonsen, *J. Chem. Soc.* (1931), 3001.

¹³ *J. Chem. Soc.* **123** (1923), 549. See also Gibson and Simonsen, *J. Chem. Soc.* (1929), 305, 909.

Δ^4 -Carene

(Δ^2 -Carene)

C₁₀H₁₆

Mol. Weight 136.23

Pinonene

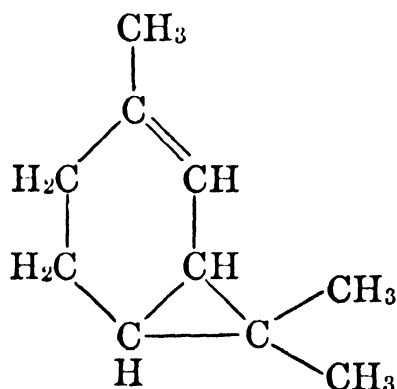

Occurrence.—*d*- Δ^4 -Carene occurs in many volatile oils, for example, in Swedish and Finnish turpentine oil, also in German pine needle oil (*Pinus sylvestris* L.). Simonsen¹ found that the oil distilled from the grass *Andropogon iwarancusa* contains about 24 per cent Δ^4 -carene. This hydrocarbon

has also been reported by Rao, Shintre and Simonsen ² in the ethereal oil from the fruit of *Piper cubeba* L.

Neither the laevo-rotatory nor the optically inactive Δ^4 -carene has been detected in plant oils. On the other hand, both have been synthetically derived and characterized. The compound suggested as *l*- Δ^4 -carene was obtained by Menon and Simonsen ³ in the distillation of *l*-caryl methyl xanthogenate. This work was questioned by Ruzicka ⁴ and needs further study. The *dl*- isomer was prepared by the Wolff-Kishner reduction of piperitenone hydrazone and described by Naves and Papazian.⁵

Isolation.—By fractional distillation.

Identification.—(1) When oxidized with potassium permanganate in acetone solution, Δ^4 -carene, according to Simonsen,⁶ gives in good yield a liquid ketonic acid $C_{10}H_{16}O_3$, viz., *d*-1,1-dimethyl-2- γ -ketobutylcyclopropane-3-carboxylic acid. This acid can be characterized by the preparation of its oxime, m. 124° – 125° , and its semicarbazone m. 119° – 120° .

(2) Oxidation with Beckmann's chromic acid mixture, according to Gibson and Simonsen,⁷ yields mainly *l-trans*-caronic acid m. 202° – 203° .

(3) By the action of hydrogen chloride in glacial acetic acid, Δ^4 -carene is converted into dipentene dihydrochloride m. 48° – 50° , and sylvestrene dihydrochloride m. 72° , the cyclopropane ring undergoing fission.

If present only in small quantities, Δ^4 -carene is somewhat difficult to identify, as it yields no crystalline derivative.

Properties.—*d*- Δ^4 -Carene is a colorless mobile oil possessing a rather pleasant odor suggestive of *p*-cymene. Simonsen ⁸ reported these properties:

b_{707}	165.5° – 167°	$[\alpha]_D^{30}$	$+62^\circ 12'$
d_{30}^{30}	0.8552	n_D^{30}	1.474

Δ^4 -Carene shows a marked exaltation (+0.5) due to the conjugation of the ethylenic linkage with the cyclopropane ring.

By oxygen or on exposure to air, Δ^4 -carene is much more slowly oxidized than Δ^3 -carene.

Use.—Due to the difficulty of preparing quantities of Δ^4 -carene, this terpene, as such, has not found any noteworthy use.

¹ *J. Chem. Soc.* **119** (1921), 1644; **121** (1922), 2292. *J. Soc. Chem. Ind.* **42**, (1923), 29A.

² *J. Soc. Chem. Ind.* **47** (1928), 93T. *Chem. Zentr.* I (1928), 2414.

³ *J. Indian Inst. Sci.* [A], **10** (1927), 2, 4. *Chem. Zentr.* II (1927), 1473.

⁴ *Helv. Chim. Acta* **15** (1932), 957.

⁵ *Ibid.* **25** (1942), 984. *Chem. Abstracts* **37** (1943), 1709.

⁶ *J. Chem. Soc.* **119** (1921), 1644; **121** (1922), 2292. *J. Soc. Chem. Ind.* **42** (1923), 29A.

⁷ *J. Chem. Soc.* (1929), 909.

⁸ *Ibid.* **121** (1922), 2292.

$C_{10}H_{18}$

Thujane

Mol. Weight 138.24

Sabinane

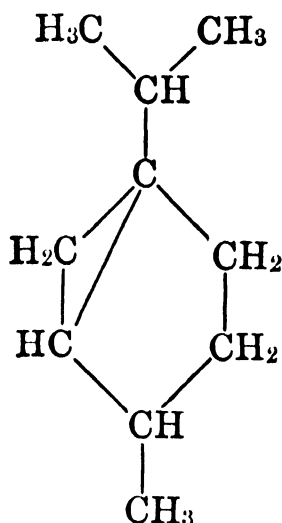

Years ago, Seyler¹ isolated from sage oil a terpene b. 142° – 145° which he named “salvene”; he assigned to it the formula now known to be that of thujane. The actual constitution of Seyler’s “salvene” has not been elucidated.

d-Thujane (tanacetane or dihydrosabinene) was first prepared synthetically by Tschugaev and Fomin.² More recently Guha and co-workers³ have effected a total synthesis of this terpene.

Occurrence.—In oil of sage (?).

Isolation.—By fractional distillation.

Identification.—The identification of thujane is difficult as this hydrocarbon yields no characteristic crystalline derivatives from which it may be regenerated.

Properties.—*d*-Thujane is a colorless, mobile oil possessing a faint odor.

Tschugaev and Fomin⁴ reported these properties for *d*-thujane prepared from *d*- α -thujene and *d*- β -thujene by catalytic hydrogenation:

<i>Derived from d-α-Thujene</i>		<i>Derived from d-β-Thujene</i>	
b ₇₅₈	157°	b ₇₅₉	157°
d ₄ ²⁰	0.8139	d ₄ ¹⁶	0.8191
d ₄ ¹⁶	0.8161	[α] _D	+34° 43'
[α] _D	+62° 2'	n _D ¹⁶	1.44102
n _D ²⁰	1.43759		

In other literature on this compound, similar discrepancies regarding optical rotation appear, depending on the source of the production. Products obtained by the reduction of sabinene seem to be particularly erratic. These have been critically investigated by Richter, Wolff and Presting,⁵ who recommend care in drawing conclusions as to the nature of the compound obtained

by catalytic reduction. Tschugaev and Fomin ⁶ and the above-mentioned authors observed for the dihydrosabinenes:

b.	157°–158° ⁶	α_D^{100}	+12° 40' ⁵
b ₁₈	50.4°–50.7° ⁵	$[\alpha]_D$	+18° 34' ⁶
d ₄ ¹⁸	0.8150 ⁵	n _D ¹⁸	1.4409 ⁵
d ₄ ¹⁷	0.8190 ⁶	n _D ¹⁷	1.44393 ⁶

Thujanes produced from β -thujone by Kishner,⁷ Richter, Wolff and Presting,⁸ and Guha and Nath ⁹ yielded these characteristics:

b.	155°–156° ⁹	$[\alpha]_D$	+48° 0' ⁸
b ₇₅₆	157.2°–157.7° ⁸		+42° 3' ⁷
b ₇₅₃	157° ⁷	$[\alpha]_D^{26}$	+49° 24' ⁹
b ₁₅	46.2°–46.8° ⁸	n _D ²⁰	1.4435 ⁹
d ₀ ²⁰	0.8171 ⁷		1.440 ⁷
	0.8120 ⁹	n _D ¹⁶	1.442 ⁸
d ₄ ¹⁵	0.820 ⁸		

The completely synthetic preparation of Guha and Nath had these properties:

b.	156°–157°	$[\alpha]_D^{20}$	+8° 29'
d ₄ ²²	0.8140	n _D ²⁰	1.4410

Use.—Thujane is not used in our industries.

¹ *Ber.* **35** (1902), 550.

² *Compt. rend.* **151** (1910), 1058. See also Richter, Wolff and Presting, *Ber.* **64** (1931), 876.

³ *Ber.* **70B** (1937), 931, 2112.

⁴ *Compt. rend.* **151** (1910), 1060.

⁵ *Ber.* **64** (1931), 876.

⁶ *Compt. rend.* **151** (1910), 1061.

⁷ *J. Russ. Phys. Chem. Soc.* **43** (1911), 586; **44** (1912), 1760.

⁸ *Ber.* **64** (1931), 876.

⁹ *Ber.* **70** (1937), 935.

α -Pinene

C₁₀H₁₆

Mol. Weight 136.23

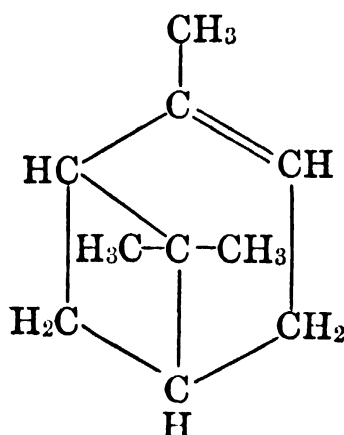

This parent hydrocarbon occupies a focal position among the terpenes and has been the subject of many investigations, the discussion of which would

lead too far for our purpose. α -Pinene is also of great commercial interest as it forms the starting material for synthetic camphor, borneol, terpineol, etc. However, we shall confine ourselves, in these pages, to only the most important reactions connected with the isolation and identification of this hydrocarbon. The reader interested in further details is referred to Simonsen's treatise: "The Terpenes," Vol. II (1932), p. 88.

Occurrence.—Several stereoisomeric forms of this terpene are found in natural products. α -Pinene is present in many oils distilled from leaves, barks, and woods. It forms the principal constituent of the turpentine oils distilled from the oleoresin of several genera and species belonging to the family *Pinaceae*.

d- α -Pinene occurs in Greek turpentine oil (*Pinus halepensis* Mill.) (about 95 per cent), in Russian turpentine oil (*Pinus sylvestris*) (about 81 per cent), in hinoki wood oil (about 70 per cent), in the oil distilled from the wood of *Chamaecyparis lawsoniana* Parl. (about 60 per cent); smaller quantities are found in American turpentine oil, and in numerous other essential oils.

l- α -Pinene occurs in Spanish turpentine oil (*Pinus laricio monspeliensis* Hort.) (about 90 per cent), in Austrian turpentine oil (*Pinus laricio* var. *austriaca* Endl.) (about 96 per cent), in French and American turpentine oil, in *Pinus pumilio* oil, in the leaf oil from *Abies alba*, and in many other essential oils.

dl- α -Pinene has been found in oil of lemon, olibanum, coriander seed, cumin seed, American peppermint, etc.

α - and β -Pinene probably occur as mixtures in many pinene-containing oils, the rotatory power of the fractions most likely being determined by the preponderance of the *d*- or *l*-modification. This feature is important in the isolation of the optically active forms from essential oils or from their fractions.

Isolation.— α -Pinene can be isolated from essential oils by fractional distillation and subsequent further purification.

d- α -Pinene may be obtained, for example, from Greek turpentine oil by first warming the oil with solid potassium hydroxide, steam distilling, and then refractionating the terpene over metallic sodium.

l- α -Pinene may be obtained from French turpentine oil by treating the oil with alkali carbonate, and then further purifying it by fractional distillation, collecting the main fraction that distills near 156° at 760 mm.

α -Pinene is one of the few terpenes which can be obtained in relatively, but not optically, pure form. To obtain the inactive α -pinene resort should first be made to the nitrosochloride derivative (cf. Tilden¹). This *dl*-product can be decomposed, according to Wallach,² by boiling with aniline in alcoholic solution, whereby the terpene is regenerated. For this purpose, reflux 10 g. of pinene nitrosochloride, 30 cc. of aniline, and 80 cc. of alcohol and steam distill after the violent reaction has subsided. Free the cold distillate from aniline by repeated extraction with an excess of aqueous acetic acid. The α -pinene thus obtained will always be optically inactive.

Optically inactive α -pinene can also be prepared by decomposition of the methylpinocamphylxanthate m. 60.5°–61°, through heating to 170°–190°, according to Tschugaev.³

Methods for the preparation of the active nitrosochlorides of this terpene and subsequent isolation of the active forms of the hydrocarbon have been successfully worked out. As several details influence the success and yield of the reaction, the final procedure adapted by Thurber and Thielke ⁴ is described below:

"To 40 cc. of *l*- α -pinene, 40 cc. of methyl alcohol (containing 10 per cent water by volume) and 40 cc. ethyl nitrite were added. The mixture was placed in a wide-mouthed bottle closed with a stopper bearing thermometer and mechanical stirrer, and was kept at a temperature of -20° during the addition of the theoretical amount of hydrochloric acid. The hydrochloric acid solution was prepared by passing hydrogen chloride gas into 90 per cent methyl alcohol until an approximately 5N solution was obtained. It was found to be advisable to introduce the cold alcohol-acid solution below the surface of the liquid and to cool the addition tube through which the acid flowed in order to prevent local superheating. A period of approximately two and one-half hours was required for the addition. After all of the acid had been added the reaction mixture was allowed to stand for a short time and was then filtered to remove the inactive derivative which had precipitated. The filtrate was immediately cooled to -20° and another 200 cc. of cold 90 per cent methyl alcohol added to it. The mixture was then allowed to stand for twenty-four hours, the temperature being maintained at -20° , to insure complete precipitation of the active nitrosochloride. Some crystals usually appeared almost immediately after the addition of the cold 90 per cent alcohol. The crystals were removed by filtration and purified by recrystallization from 1:2 mixture of chloroform and methyl alcohol."

The dextro compound was obtained by a similar type of reaction. These authors obtained the following constants on the nitrosochlorides of the α -pinenes:

	<i>dl</i> -	<i>d</i> -	<i>l</i> -
m.	115°	89.5°	90°
$[\alpha]_D^{20}$ (in benzene)	0°	+396° 12'	-366° 48'

Lynn ⁵ had earlier investigated these products and reported the *d*- and *l*- modifications with m. 81°-81.5° and $\alpha_D \pm 322^{\circ} 0'$ (in chloroform solution). These variations may be explained if an analogy is drawn from the findings of Berry, Macbeth and Swanson ⁶ relative to the effect of heat and solvent on the α - and β - forms of the nitrosochlorides of α -phellandrene. In this latter case, solution in benzene yields a much higher optical rotation than solution in chloroform. Furthermore, certain methods of purification used serve to separate an unstable and stable form. Other peculiarities in connection with α -pinene nitrosochloride preparations have been observed by many authors besides those cited above, among them Kremers,⁷ Tilden,⁸ Schimmel & Co.,⁹ Gildemeister and Kohler,¹⁰ and Fuzita.¹¹ Much study is still necessary to interpret the significance of the data on these compounds and their derivatives, in the opinion of Earl and Hazelwood,¹² Leach,¹³ Wallach,¹⁴ Lynn,¹⁵ Briggs and Sutherland,¹⁶ and Earl and Kenner.¹⁷

The method of Tilden ¹⁸ or Wallach ¹⁹ serves for regenerating the *d*- and *l*- α -pinene from these optically active nitrosochlorides.

In order to isolate the optically active modifications of α -pinene, it is advisable to start with an α -pinene fraction possessing a high optical rotation, taking into consideration, however, the possibility that the high rotation may be caused by the presence of camphene. The portions boiling below 160° at 760 mm. are purified by fractional distillation over metallic sodium until the boiling point and the other properties of the hydrocarbons thus obtained coincide with those of optically inactive α -pinene.

For the purification of this terpene from β -pinene as a contaminant, the worker is referred to the data of Austerweil²⁰ who recommends the use of differential solubility in alcohol, in addition to rectification as a means of separating the β -isomer.

Solubility in 100 Volumes Ethyl Alcohol

% Alc. Concentration	Volumes Soluble	
	β -	α -
95	35.8	30.4
90	13.0	9.75
85	8.25	5.1
80	6.0	2.3
70	1.6	0.2
60	0.5	trace

Identification.— α -Pinene can be characterized by several methods:

(1) The preparation of the optically inactive nitrosochloride.

Wallach²¹ suggested the following method for preparing the optically inactive nitrosochloride:

Cool a mixture of 50 g. each of turpentine oil (dextro- or laevorotatory, but not with too high a rotation), 50 g. of glacial acetic acid and 50 g. of ethyl nitrite (or preferably amyl nitrite) in a freezing mixture and gradually add 15 cc. of crude, 33% hydrochloric acid. The nitrosochloride soon separates in crystalline form and may be obtained in a fairly pure state by filtering it off with a suction pump and by washing it thoroughly with alcohol. From the filtrate more nitrosochloride separates on standing in the cold.

Tilden²² also prepared this compound later and found a melting point of 115° for an apparently stable form after a thorough washing with alcohol and recrystallization from chloroform. This has been confirmed by subsequent investigators.

The ethyl nitrite necessary for this reaction is easily obtained by allowing a mixture of 200 g. of concentrated sulfuric acid, 1.5 liters of water, and 100 g. of alcohol to flow into a solution of 250 g. of sodium nitrite in 1 liter of water and 100 g. of alcohol. The ethyl nitrite which forms and volatilizes at once during this reaction must be condensed in a well-cooled receiver. In order to obtain a good yield of nitrosochloride, it is advisable to work with small quantities only. It will thus be possible to keep the temperature low, a feature important for the success of the reaction. As a by-product, large quantities of pinol $C_{10}H_{16}O$ are formed.

A better yield of nitrosochloride is obtained, according to Ahlström and Aschan,²³ if the mixture of turpentine oil, glacial acetic acid, and ethyl nitrite is saturated, at very low temperature, with a current of dry hydrochloric acid.

Another method well suited for the preparation of terpene and sesquiterpene nitrosochlorides is that of Ehestädt.²⁴ A quantity of oil of turpentine is diluted with an equal volume of petroleum ether, glacial acetic acid, or ether. The nitrosyl chloride gases are conducted into this solution, well cooled with a freezing mixture. Prepare them by permitting a concentrated sodium nitrite solution to drop slowly into (32%) crude hydrochloric acid. The quantity of hydrochloric acid should be $1\frac{1}{2}$ times the theoretically necessary quantity. The hydrochloric acid must not flow into the sodium nitrite solution as this will give a very low yield. After about one-third of the sodium nitrite solution is consumed, the pinene nitrosochloride will separate in the form of

crystals, but toward the end of the reaction the mixture will consist of a mash. The contributions by Thurber and Thielke ²⁵ may also be helpful in this connection. (See previous section.)

(2) A further confirmatory derivative is the chloride. The preparation of the *d*-, *l*-, and *dl*- compounds with normal behavior has been reported by Thurber and Thielke.²⁶ They noted these properties:

	<i>m.</i> °C. (<i>corr.</i>)	$[\alpha]_D^{20}$ (1% alcohol solution)
<i>dl</i> - α -pinene hydrochloride	132	0°
<i>d</i> - α -pinene hydrochloride	132	+33° 31'
<i>l</i> - α -pinene hydrochloride	132	-33° 14'

(3) α -Pinene forms a crystalline adduct with maleic anhydride that Hultzsch ²⁷ describes as *m.* 169°.

(4) The presence of α -pinene may be established by oxidation of the terpene with potassium permanganate to pinonic acid.

For this purpose Thurber and Roll ²⁸ recommend an economical and convenient method:

“An emulsion of 50 g. of pinene in 300 cc. of water was gradually added to 120 g. of potassium permanganate contained in a liter of water. The mixture was cooled in an ice bath and stirred continuously during the addition. After completion of the oxidation the manganese sludge was removed by filtration; the filtrate saturated with carbon dioxide gas and distilled with steam to remove unoxidized products. The liquid was evaporated in a current of carbon dioxide to a volume of 400 cc. and then extracted with two 50 cc. portions of ether. The pinonic acid was set free from the potassium salt by the addition of dilute sulfuric acid. After extraction with ether and recrystallization from petroleum ether the acid melted at 68° C.”

Oxidation of *d*- and *l*- α -pinene thus yields the optically active pinonic acids *m.* 67°–69°, $[\alpha]_D^{25} +89^\circ 0'$ and $[\alpha]_D^{20} -90^\circ 33'$ (in chloroform solution), according to Barbier and Grignard ²⁹; whereas the oxidation of *dl*-pinene, according to Dupont and Brus,³⁰ yields *dl*-pinonic acid in very good yield. The *dl*- acid *m.* 103°–104° (Briggs and Sutherland ³¹ *m.* 104°–105°, *b*₅ 155°–161°) is the *cis*- acid, while the liquid acids that are always obtained simultaneously are a mixture of the *cis*- and *trans*- modifications, according to Perkin and Simonsen.³² Komppa and Beckmann ³³ expressed the opinion that pinonic acid is actually α -campholonic acid.

For the definite identification of the pinonic acid, it is advisable to prepare the characteristic semicarbazone which was first described by Tiemann and Kerschbaum.³⁴ The *d*- and *l*-semicarbazone melts at 204°, the *dl*-semicarbazone at 206°–207°.

For the identification of α -pinene, it suffices to oxidize the terpene to pinonic acid and to prepare the semicarbazone of the latter. But if optically active and inactive α -pinene must be identified side by side, it will be necessary to fractionate the acids *in vacuo*, *b*₁₂ 168°, to isolate them in pure form, and to characterize the isomers as described above.

(5) For the identification of small quantities of α -pinene, Agnew and Croad ³⁵ suggested oxidizing it with mercuric acetate to sobrerol *m.* 131°, and to 8-hydroxycarvotanacetone, which may in turn be characterized by the preparation of its semicarbazone *m.* 175°.

Lead tetracetate on pinene also gives *dl*-sobrerol (pinol hydrate) *m.* 130°–130.5°, according to Ward.³⁶ The active forms: *m.* 150°, $[\alpha]_D \pm 150^\circ 0'$.

Properties.— α -Pinene is a colorless, mobile oil which, like most terpenes, partly resinifies on exposure to air.

This hydrocarbon has a tendency to isomerize under the influence of heat, acids, or catalysts. Certain data of Thurber and Johnson,³⁷ and Brus³⁸ indicate that varied natural sources yield α -pinene fractions of varied physical properties. These factors may in part account for the inability of investigators to obtain concordant results in measurements made on preparations of α -pinene. Nevertheless the following properties of α -pinene appear to have been substantiated in recent investigations. The pinenes were obtained by fractionation over sodium in some cases, and by regeneration from the nitrosochlorides in others, and from various sources (Thurber and Roll,³⁹ Schorger,^{40, 41} Thurber and Thielke,⁴² Frankforter and Frary,⁴³ Conant and Carlson,⁴⁴ Brus,⁴⁵ Darmois,⁴⁶ Waterman, van't Spijker and van Westen,⁴⁷ Austerweil,⁴⁸ and Ross and Somerville⁴⁹):

	<i>d</i>	<i>l</i>	<i>dl</i>
b.	156°–156.5° ^{39, 40, 44}	156°–157° ⁴¹	156.2° ⁴⁷
	155°–156° ⁴²	155°–156° ⁴²	155°–156° ⁴²
m.	–57° ^{45, 48}	–55° ⁴⁶	–120.2° ⁴⁹
d_{20}	0.8584–0.8600 ^{39, 42, 44}	0.8590–0.8598 ^{41, 42, 43}	...
d_4^{20}	0.8582–0.8592 ^{42, 47}
d_{15}	0.8631 ⁴⁰
$[\alpha]_D^{20}$	+51° 8' ⁴²	–51° 17' ⁴²	...
n_D^{20}	1.4658–1.4663 ^{42, 44}	1.4662–1.4670 ^{41, 42}	1.4658–1.4664 ^{42, 47}
n_D^{15}	1.4684 ⁴⁰

Although higher optical rotations on pinenes from American sources ranging up to +53° 55' and –54° 2' have been reported by Lynn,⁵⁰ Thurber et al.,⁵¹ and Schorger,⁵² nevertheless there remains a question whether these exalted values for $[\alpha]_D$ may not be due to solvent effects. It has been shown in the work of Thurber and Thielke,⁵³ and of Naves,⁵⁴ that solutions of pinene in certain solvents display higher rotations than the homogeneous compound. This apparent exaltation is especially true of alcohols, the type of solvent reported to have been used in several of the above determinations. These optimum optical values appear to have been obtained from pinenes of varied natural origin and by diverse methods of purification. Competent workers abroad continue to record values near $\pm 48^\circ 0'$, the maximum figures reported on several natural α -pinenes being of similar magnitude (Brus⁵⁵ for α -pinene from Greek turpentine oil +48° 51', and Smith⁵⁶ for α -pinene from Australian eucalyptus oil $[\alpha]_D^{19}$ –48° 38').

Like other bicyclic terpenes, α -pinene shows a marked tendency toward molecular rearrangement leading to substances with a different ring structure,

this may be caused by oxidation, hydrogenation, hydration, or by the action of acids, catalysts, or heat, etc. These reactions have become of great technical importance in the synthesis of borneol, camphor, and other products. Interesting as they are, unfortunately they cannot be discussed in these restricted pages. A number of literature references to them, however, have been appended to this section.

Use.—The principal use of α -pinene is in the manufacture of synthetic borneol, camphor, and terpineol. α -Pinene also serves as an important constituent in many artificial (imitation) essential oils.

Fractions containing α - and β -pinene are widely used as solvents, and as odor adjuncts in many technical preparations—bath salts, room sprays, disinfectants, insecticides, etc. Lately α - and β -pinene are being used for the synthesis of artificial white pine oil.

- ¹ *J. Chem. Soc.* **28** (1875), 514; **85** (1904), 760.
- ² *Liebigs Ann.* **252** (1889), 132; **258** (1890), 343.
- ³ *J. Russ. Phys. Chem. Soc.* **39** (1907), 1330.
- ⁴ *J. Am. Chem. Soc.* **53** (1931), 1030.
- ⁵ *Ibid.* **41** (1919), 364.
- ⁶ *J. Chem. Soc.* (1939), 466, 1418.
- ⁷ *Proc. Wis. Pharm. Asscn.* (1891), 39; (1892), 66, 72.
- ⁸ *J. Chem. Soc.* **85** (1904), 759.
- ⁹ *Ber. Schimmel & Co.*, April (1910), 164.
- ¹⁰ *Wallach Festschrift* (1909), 432.
- ¹¹ *J. Chem. Soc. Japan* **57** (1936), 578. *Chem. Abstracts* **30** (1936), 7560.
- ¹² *J. Chem. Soc.* (1937), 374.
- ¹³ *Ibid.* **91** (1907), 1.
- ¹⁴ *Liebigs Ann.* **245** (1888), 253; **252** (1889), 130, 132; **258** (1890), 343; **268** (1892), 216.
- ¹⁵ *J. Am. Chem. Soc.* **41** (1919), 361.
- ¹⁶ *J. Org. Chem.* **7** (1942), 402.
- ¹⁷ *J. Chem. Soc.* (1927), 1269.
- ¹⁸ *Ibid.* **85** (1904), 759.
- ¹⁹ *Liebigs Ann.* **252** (1889), 132; **258** (1890), 343.
- ²⁰ *Chimie & industrie*, Spec. No. 603, Sept. (1926). *Chem. Abstracts* **21** (1927), 818.
- ²¹ *Liebigs Ann.* **245** (1888), 251. Wallach and Otto, *ibid.* **253** (1889), 251.
- ²² *J. Chem. Soc.* **85** (1904), 761.
- ²³ *Ber.* **39** (1906), 1445, footnote.
- ²⁴ *Ber. Schimmel & Co.*, April (1910), 165.
- ²⁵ *J. Am. Chem. Soc.* **53** (1931), 1030.
- ²⁶ *Ibid.* 1032.
- ²⁷ *Ber.* **72B** (1939), 1181.
- ²⁸ *Ind. Eng. Chem.* **19** (1927), 739.
- ²⁹ *Bull. soc. chim.* [4], **7** (1910), 551, 556.
- ³⁰ *Ann. chim.* IX, **19** (1923), 186.
- ³¹ *J. Org. Chem.* **7** (1942), 402.
- ³² *J. Chem. Soc.* **95** (1909), 1174.
- ³³ *Ber.* **69** (1936), 2783.
- ³⁴ *Ber.* **33** (1900), 2664. Cf. Gildemeister and Hoffmann, "Die Ätherischen Öle," 3d Ed., Vol. I, 352.
- ³⁵ *Analyst* **37** (1912), 295.
- ³⁶ *J. Am. Chem. Soc.* **60** (1938), 325. Cf. Armstrong and Pope, *J. Chem. Soc.* **59** (1891), 317.
- ³⁷ *Ibid.* **52** (1930), 786.
- ³⁸ *Bull. inst. pin* (1929), 271.

- ³⁹ *Ind. Eng. Chem.* **19** (1927), 740.
⁴⁰ *Ibid.* **6** (1914), 631.
⁴¹ *J. Am. Chem. Soc.* **39** (1917), 1042.
⁴² *Ibid.* **53** (1931), 1030.
⁴³ *Ibid.* **28** (1906), 1461.
⁴⁴ *Ibid.* **51** (1929), 3467.
⁴⁵ *Bull. inst. pin* (1929), 276.
⁴⁶ *Compt. rend.* **149** (1909), 732.
⁴⁷ *Rec. trav. chim.* **48** (1929), 1195.
⁴⁸ *Chimie & industrie*, Spec. No. 603, Sept. (1926). *Chem. Abstracts* **21** (1927), 818.
⁴⁹ *J. Chem. Soc.* (1926), 2777.
⁵⁰ *J. Am. Chem. Soc.* **41** (1919), 361.
⁵¹ *Ibid.* **53** (1931), 1030. *Ind. Eng. Chem.* **19** (1927), 740.
⁵² *Ind. Eng. Chem.* **6** (1914), 631.
⁵³ *J. Am. Chem. Soc.* **53** (1931), 1030.
⁵⁴ *Compt. rend.* **213** (1941), 570.
⁵⁵ *Bull. inst. pin* (1929), 276.
⁵⁶ *J. Proc. Roy. Soc. N. S. Wales* **32** (1898), 203.

SUGGESTED ADDITIONAL LITERATURE

- Prilezhaev and Vershuk, "The Composition of Turpentine Oil: Oxides of α - and β -Pinene," *Chem. Zentr.* II (1929), 2556.
 N. Prilezhaev and V. Vershuk, "The Oxide of α -Pinene in the Grignard Reaction," *J. Russ. Phys. Chem. Soc.* **61** (1929), 473.
 Georges Dupont and Jean Crouzet, "The Oxidation of Pinenes in Presence of Catalysts," *Bull. inst. pin* (1929), 101.
 P. Lipp (with H. Witgert), "Pinane. The Determination of Nopinene," *Ber.* **63B** (1930), 411.
 Marcel Delépine, Jean Reisman and Edouard Suau, "The Action of Several Organic Acids on *d*- α -Pinene," *Bull. soc. chim.* [4], **47** (1930), 966.
 Paul Adrien Mulcey, "Isomerization of Pinene in Presence of Alumina," *Bull. inst. pin* (1931), 177, 201.
 B. A. Arbusov, "Isomerization of α -Pinene to Aliphatic Terpene," *Chem. Zentr.* II (1933), 2125.
 G. Dupont, J. Allard, and R. Dulou, "Oxidations by Selenium Oxide in the Terpene Series," *Bull. soc. chim.* [4], **53** (1933), 599.
 T. Mochida, "Terpenes and Camphors. Isomerization of α -Pinene by Activated Charcoal," *J. Pharm. Soc. Japan* **53** (1933), 936; *Abstracts* (in German), 172.
 Hans Meerwein and Julius Vorster, "Pinene Hydrochloride," *J. prakt. Chem.* **147** (1937), 83.
 Ralph W. Charlton and Allan R. Day, "Hydration and Isomerization of Pinene," *Ind. Eng. Chem.* **29** (1937), 92.
 Donald H. Sheffield (to Hercules Powder Co.), "Recovery of Terpenes from Mixtures," U. S. Patent No. 2,097,743, November 2, 1938.
 G. Dupont and R. Dulou, "The Pyrolysis of Pinene. I. The Pyronenes," *Atti X^o Congr. intern. chim.* **3** (1939), 123 (in French). *Chem. Abstracts* **33** (1939), 9312.
 L. A. Goldblatt and S. Palkin, "Vapor Phase Thermal Isomerization of α - and β -Pinene," *J. Am. Chem. Soc.* **22** (1941), 3517. P. C. Guha and A. N. Roy, "II. Conversion of α - and β -pinenes into bornyl acetate by acetic acid in presence of catalysts." "III. (a) Catalytic isomerization of α -pinene and β -pinene to camphene. (b) Synthesis of camphor from pinene and pinene-camphene mixture," *J. Indian Inst. Sci.* **23A** (1941), 208, 217. *Chem. Abstracts* **36** (1942), 4967.

Wm. J. Kirkpatrick (to Hercules Powder Co.), "Isomerization of Pinene to Camphene," U. S. Patent No. 2,385,711, September 25, 1945. *Chem. Abstracts* **40** (1946), 607.

G. A. Rudakov, "Catalytic Transformation of Terpenes. Catalytic Transformations of α -Pinene in the Presence of Activated Clays." *J. Gen. Chem. U.S.S.R.* **16** (1946), 261. *Chem. Abstracts* **41** (1947), 114.

V. M. Nikitin (Arkhangel Forest Inst.), "Products of Thermal Isomerization of α -Pinene. Influence of Temperature on the Isomerization Process," *J. Gen. Chem. U.S.S.R.* **16** (1946), 1041 (in Russian). *Chem. Abstracts* **41** (1947), 2712.

V. M. Nikitin, "Products of Thermal Isomerization of α -Pinene. Mechanism of the Isomerization," *J. Gen. Chem. U.S.S.R.* **16** (1946), 1475 (in Russian). *Chem. Abstracts* **41** (1947), 5487.

R. Lombard, "The Autoxidation-polymerization of Pinene," *Bull. Soc. Chim. France* (1947), 251. *Chem. Abstracts* **41** (1947), 6550.

β -Pinene

(Nopinene)

$C_{10}H_{16}$

Mol. Weight 136.23

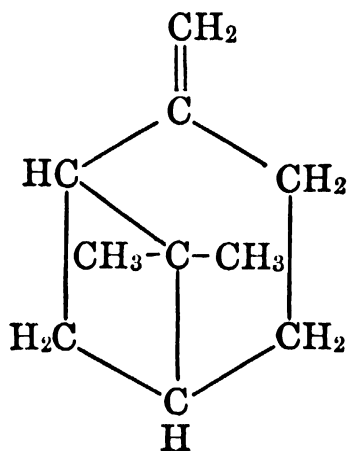

Occurrence.— β -Pinene often accompanies α -pinene in turpentine oils, although usually only in small quantities. French turpentine oil is especially rich in β -pinene, which occurs also in other essential oils—for example, lemon, nutmeg, hyssop, coriander and cumin seed, etc.

d- β -Pinene has been identified in sulfaturpentine oil and in the oil distilled from the ripe fruit of *Ferula galbaniflua*.

l- β -Pinene is present in Oregon balsam, in the needle oil of the Douglas fir (48 per cent) and of various *abies* and *pinus* species, in the oil of petitgrain, etc.

dl- β -Pinene has been reported by Rutovskii and Vinogradova,¹ as associated with the racemic form of the α - isomer, in *Ferula galbaniflua*.

Isolation.—Fractional distillation continues to be the recommended method of separation from α -pinene. Dupont² prepared very pure β -pinene by fractionating French turpentine oil in a column 2 m. high.

Austerweil³ suggested separating β -pinene from α -pinene by taking advantage of the greater solubility of β -pinene in alcohol. One hundred volumes of alcohol of 80% strength dissolve only 2.3 volumes of α -pinene, but 6 volumes of β -pinene. In alcohol of 70% strength, the solubility is 0.2 and 1.6 volumes, respectively, at 15°.

Otherwise, β -pinene resembles α -pinene closely in its general reactions, for which reason the separation of the two hydrocarbons is difficult.

Identification.—The methods developed so far for the identification of β -pinene cause a substantial change in the molecule, and do not lend themselves to small quantities. Low yield and the separation of numerous by-products increase the difficulties connected with the chemical identification of this terpene. The worker may be faced with products of oxidative degradation such as pinocarvone, nopinic acid, myrtenols, etc. (Dupont,⁴ Rutovskii and Vinogradova,⁵ Lipp,⁶ Dupont, Allard and Dulou,⁷ Dupont, Zacharewicz and Dulou,⁸ and Schmidt.⁹) Therefore, it is preferable, for qualitative identification simply to isomerize the hydrocarbon and to characterize it by derivatives of the isomer. For instance, the isomerization of 38.5 g. of β -pinene b_{758} 164.5°–165.8°, α_D $-21^\circ 36'$, n_D^{20} 1.4790, by a palladium catalyst and hydrogen, gives 37 g. of the α -isomer b_{758} 156.6°–156.8°, α_D $-40^\circ 0'$, n_D^{20} 1.4647 (Richter and Wolff¹⁰). The α -pinene yields several derivatives in which contaminants are not so frequent, nor the yields so low as is the case in chemical treatment of the β -compound *per se*. (See “ α -Pinene” and Addenda to this section.)

Gasopoulos¹¹ suggested distinguishing β -pinene from α -pinene by the following reaction:

If α - or β -pinene is added to an alcoholic solution of mercuric acetate, the mixture containing β -pinene will remain clear even after 2–3 days, whereas the mixture containing α -pinene will separate mercurous acetate, with oxidation of α -pinene to sobrerol and hydroxyhydrocarvone.

Properties.—Dupont et al.¹² characterized *l*- β -pinene obtained by fractional distillation of French turpentine oil:

m.	-50°	α_D	$-22^\circ 6'$
b.	164°	n_D^{20}	1.4872
d_{15}	0.8740		

Isolating *l*- β -pinene from hyssop oil, Schimmel & Co.¹³ found the following properties:

b.	164° – 166°	α_D	$-19^\circ 29'$
d_{15}^{15}	0.8650	n_D^{20}	1.47548

The *d*- β -pinene of Rutovskii and Vinogradova¹⁴ was observed to boil at 162° – 163° , confirming findings of both Austerweil¹⁵ and Wallach¹⁶ on the *l*-isomer. The *dl*- β -form has not been characterized.

Use.—(See “ α -Pinene.”)

¹ *J. prakt. Chem.* **120** (1929), 41.

² *Chimie & industrie* **8** (1922), 549. *Ann. chim.* [10], **1** (1924), 184.

³ *Chimie & industrie* Spec. No. 603, Sept. (1926).

⁴ *Bull. inst. pin* (1929), 269.

⁵ *Trans. Sci. Chem. Pharm. Inst. Moscow* No. 22 (1930), 72. *Chem. Abstracts* **24** (1930), 5932.

⁶ *Ber.* **63** (1930), 411.

⁷ *Bull. soc. chim.* [4], **53** (1933), 599.

⁸ *Compt. rend.* **198** (1934), 1699.

⁹ *Ber. Schimmel & Co.* (1941), 70. *Chem. Abstracts* **37** (1943), 4715.

¹⁰ *Ber.* **59** (1926), 1736. See also Lipp, *Ber.* **63** (1930), 411.

¹¹ *Ber.* **59** (1926), 2184.

¹² *Bull. soc. chim.* [4], **53** (1933), 602. See also *Bull. inst. pin* (1932), 110.

¹³ *Ber. Schimmel & Co.*, April (1908), 119.

¹⁴ *Trans. Sci. Chem. Pharm. Inst. Moscow*, No. 22 (1930), 72.

¹⁵ *Chimie & industrie Spec.* No. 603, Sept. (1926).

¹⁶ *Liebigs Ann.* **363** (1908), 10.

SUGGESTED ADDITIONAL LITERATURE

N. D. Zelinskii and R. J. Levina, "Irreversible Catalysis of Unsaturated Cyclic Hydrocarbons. Contact Transformations of Nopinene, Terpinene and Terpinolene," I. Univ. Moskau. *Ber.* **62** (1929), 339.

G. Austerweil, "Quelques Notes sur l'Hydratation du Nopinène. Hydratation par des Acides à l'État naissant," *Bull. soc. chim.* [4], **47** (1930), 1157.

Sabinene

$C_{10}H_{16}$

Mol. Weight 136.23

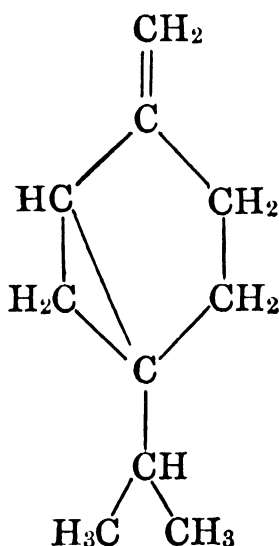

Occurrence.—*d*-Sabinene occurs as the main constituent (about 30 per cent) in oil of savin (*Juniperus sabina* L.). It is present also in Ceylon cardamom, marjoram, and orthodon oils.

l-Sabinene is found in the oil distilled from the seeds of *Xanthoxylum budrunga* Wall., in savin oil, and *Vitex negundo*, Linn.

dl-Sabinene occurs in cubeb oil, and in the oil from the leaves of *Murraya koenigii* Spreng.

Isolation.—By fractional distillation—of savin oil, for example.

Identification.—Sabinene cannot be purified through any crystalline derivative. It is best characterized by:

(1) Its very low specific gravity.

(2) Oxidation with potassium permanganate, in the presence of free sodium hydroxide, yielding the sparingly soluble sodium salt of sabinenic acid. According to Wallach,¹ the free acid melts at 57° and can be oxidized to sabinaketone $C_9H_{14}O$, the semicarbazone of which melts at 141°–142°.

According to Semmler² *d*-sabinene glycol $C_{10}H_{18}O_2$, too, may be used for the characterization of sabinene. This dextrorotatory glycol m. 54°, b_{15} 148°–150°, is obtained

by the oxidation of sabinene with potassium permanganate under carefully controlled conditions.

(3) Formation of a hydrate, characterized by Semmler ² and Wallach ³ as follows: m. 38°–39°, b. 195°–201°, $[\alpha]_D^{15} +53^\circ 40'$ (in ether).

Properties.—The physical properties of sabinene, as recorded in literature, vary considerably. Simonsen ⁴ recorded the following average values:

<i>d</i> -Sabinene			
b.	163°–165°	[α] _D	+80° 10'
d ₂₀	0.842	n _D ²⁰	1.465
<i>l</i> -Sabinene			
b ₇₀₅	161.5°–163°	[α] _D	–46° 11'
d ₃₀ ³⁰	0.8407	n _D ³⁰	1.465

Subsequent publications by Huzita,⁵ and Padmanabhan and Jatkar ⁶ note certain comparable properties for the active forms and report as optima:

b ₃₀	66° ⁶	[α] _D	+89° 4' ⁶
b ₂₀	57°–58° ⁵	n _D ³⁰	1.4460 ⁶
d ₄ ³⁰	0.8430 ⁶		

The exaltation of the molecular refraction (+1.34) is one of the highest observed in the terpene group. It must be ascribed to the conjugation of the exocyclic bond with the cyclopropane ring.

Sabinene has a tendency to pass into derivatives of α -terpinene; for example, on shaking with dilute sulfuric acid in the cold, sabinene is transformed into optically active terpinen-4-ol and 1,4-terpin. On boiling with dilute sulfuric acid, sabinene passes into terpinene. With hydrohalogens, sabinene forms terpinene dihalogenides.

Use.—Sabinene, as such, is not used in our industries.

¹ *Liebigs Ann.* **359** (1908), 270. Cf. Semmler, *Ber.* **33** (1900), 1465.

² *Ber.* **33** (1900), 1463.

³ *Liebigs Ann.* **357** (1907), 64, 77.

⁴ "The Terpenes," Vol. II (1932), 17, Cambridge, The University Press.

⁵ *J. Chem. Soc. Japan* **62** (1940), 431. *Chem. Abstracts* **36** (1942), 6754.

⁶ *J. Am. Chem. Soc.* **57** (1935), 336.



Camphene

Mol. Weight 136.23

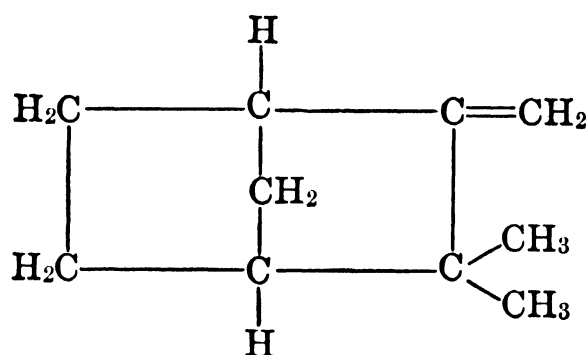

Camphene is the only $C_{10}H_{16}$ crystalline hydrocarbon found so far in essential oils. Due to its crystalline nature it has been obtained in pure form and free from isomers, which cannot be claimed of other hydrocarbons. However, in only a few cases has it been possible to isolate camphene from essential oils in crystalline form—for example, from Siberian pine needle oil.

Camphene is a bicyclic terpene of considerable interest and capable of many reactions as it tends to undergo intramolecular rearrangements. Camphene, therefore, has been the subject of numerous investigations, the discussion of which would lead too far in these pages. Suffice it to mention only that camphene can be prepared synthetically by the elimination of hydrogen chloride from bornyl chloride, or from isobornyl chloride, or even more conveniently by dehydration of isoborneol with zinc chloride. However, in this case a mixture of several hydrocarbons will be obtained.

Occurrence.—*d*-, *l*- and *dl*-Camphene occur in nature quite widely distributed:

d-Camphene has been identified in Siberian pine needle oil, in oil of cypress, camphor, lemon, orange, spike lavender, *Eucalyptus globulus*, nutmeg, ginger, etc.

l-Camphene is also found in Siberian pine needle oil, in the oil distilled from the needles of *Abies concolor*, of *Pinus palustris*, in American and Russian turpentine oil, in Ceylon citronella oil, valerian oil, etc.

dl-Camphene, too, has been found in numerous volatile oils.

Isolation.—As pointed out, the isolation of camphene from essential oils by mere crystallization has been possible only in a few instances. In most cases it will be necessary to resort to fractional distillation, or to employ an indirect method of isolation from the corresponding camphene fraction of an essential oil by converting the hydrocarbon into its chloride (with the theoretical amount of hydrogen chloride in ethereal solution), and by regenerating the camphene with alkali (see "Identification").

Identification.—Camphene may be identified by several methods.

(1) If the essential oil contains sufficient quantities of camphene, this terpene may be separated in crystalline form, the crystals melting at 51° – 52° . It is, however, always advisable to confirm the identity of camphene by hydrating it to isoborneol m. 212° , whereby some borneol is also formed. The isoborneol can be further characterized by the preparation of its bromal compound m. 71° – 72° , its phenylurethane m.

138°–139°, and its *p*-nitrobenzoate m. 129°. (See "Isoborneol" and "Borneol," and their identification.)

For the hydration of camphene to isoborneol, Bertram and Walbaum¹ recommended the following procedure:

Heat 100 parts of the camphene fraction for 2 to 3 hr. and at 50°–60° with 250 parts of glacial acetic acid and 10 parts of 50% sulfuric acid, and shake frequently. The mixture will first separate into two layers but finally become homogeneous and develop a slightly reddish color. After completion of the reaction add water, separate the acetate, wash it repeatedly with water, and saponify the acetate by heating with a solution of 50 g. of potassium hydroxide in 250 g. of alcohol. Remove the alcohol and add water. The isoborneol will precipitate as a crumbly mass. Purify by recrystallization from petroleum ether. The determination of the melting point of isoborneol (about 212°) must be undertaken in a sealed capillary tube, as otherwise the isoborneol would sublime.

When following Bertram and Walbaum's procedure, it should be kept in mind that, in addition to isoborneol, some borneol is formed. According to Aschan,² the isoborneol prepared by this reaction contains about 20% of borneol. The phenylurethanes of both borneol and isoborneol melt at 138°–139°; therefore other derivatives should be used for their identification (see above).

(2) Meerwein and van Emster³ found that, on treatment with the theoretical quantity (but no excess) of hydrochloric acid in methyl alcoholic or ethereal solution, camphene forms true camphene hydrochloride in the form of snow-white crystals m. 125°–127°. The true camphene hydrochloride possesses a strong, menthol-like odor and is extremely unstable: it cannot be recrystallized without profound change.

If camphene is further treated with hydrochloric acid, in other words, with excess hydrochloric acid, the resulting product will be isobornyl chloride m. 150°–158°, in somewhat impure form.

Camphene can be regenerated from true camphene hydrochloride and from isobornyl chloride by the action of alkali. Both true camphene hydrochloride and isobornyl chloride are optically active in the opposite sense to the camphene from which they had been prepared. This method of identifying or isolating camphene will be successful only if the corresponding fraction of the oil contains a high percentage of camphene.

(3) If only small quantities of camphene are present in an essential oil, its identification may be difficult. The best method in this case is to oxidize the hydrocarbon with potassium permanganate solution in acetic acid to camphenilone C₉H₁₄O which can be characterized through its semicarbazone m. 224°. (See "Camphenilone.")

(4) Lipp,⁴ and Hückel et al.⁵ have used the ω -nitrocamphenes satisfactorily to characterize this hydrocarbon. Lipp reported the *dl*- ω -nitrocamphene as m. 64° and the *l*- as m. 84°–85°, $[\alpha]_D -146^\circ 24'$ (in benzene), whereas Hückel and co-workers in their studies on an optically homogeneous camphene recently prepared *d*- ω -nitrocamphene with these properties (after recrystallization from petroleum ether): m. 85°; $[\alpha]_D^{21.8} +153^\circ 24'$ (in benzene), $[\alpha]_D^{23.5} +184^\circ 24'$ (in alcohol); a sample (purified in methyl alcohol) m. 85°–86° gave rotational values of $+149^\circ 36'$ (in benzene) and $+176^\circ 0'$ (in alcohol).

Properties.—Camphene is a white, crumbly, crystalline mass possessing a faint camphoraceous odor. It sublimes and is more resistant against the influence of air and light than the other terpenes.

As camphene may be obtained crystalline and free from adhering impurities by solution in alcohol and precipitation with water, this hydrocarbon should lend itself to isolation in a high state of purity. However, inspection

of the several widely variant physical properties reported by many authors (including Pariselle,⁶ Lecat,⁷ Ross and Somerville,⁸ Kachler and Spitzer,⁹ Tschugaev,¹⁰ and Eijkman¹¹) for this hydrocarbon encourages a disbelief in the purity as well as optical homogeneity of most of the compounds studied. Although the *d*-, *l*-, and *dl*- stereoisomers derived from various sources have been described, the constants reported on the natural isolates are not as high as those observed on the synthetically derived hydrocarbons. In the table below the optical rotation of the isomers exhibits a fair degree of homogeneity. The other properties may, therefore, also be considered optima.

PROPERTIES

Constants	Isomers		
	<i>d</i>	<i>l</i>	<i>dl</i>
b.	160° ^{8,14} 158.5° ¹²	159°–160° ^{16,15} ...	158°–160° ^{7,20,18} ...
b ₇₄₅	157.6° ¹³
b ₇₁₂	156.3°–156.7° (corr.) ¹⁹
b ₁₇	52° ⁶
m.	51.2° (corr.) ⁹ 50° ¹⁴	51°–52° ²¹ 49°–50° ¹⁵	50° ^{14,18,19} ...
d ₇₈	0.8223 ¹¹
d ₄ ⁵⁴	...	0.84224 ²¹	...
d ₄ ⁵⁰	0.8486 ¹²
d ₄₀	...	0.8555 ¹⁴	...
[α] _D ²⁰	+107° 42' ¹⁷ (in benzene) +99° 36' ¹⁷ (in alcohol)	–95° 34' ¹⁰ (c = 17.87 in toluene)
[α] _D ¹⁹	...	–92° 24' ¹⁵ (c = 2.2 in alcohol)	...
[α] _D ¹⁷	+103° 54' ¹⁴ (p = 9.67 in ether)
[α] _D	...	–94° 37' ¹⁶	...
n _D ⁵⁴	...	1.45514 ²¹	...
n _D ⁵⁰	1.46048 ¹²
n _D ⁴⁰	...	1.46207 ¹⁴	...

Aschan¹² studied the properties of *d*-camphene derived from American turpentine oil, while Tsakalotos and Papaconstantinou¹³ gave constants on the hydrocarbon from Greek turpentine; the *l*-camphene reported by Wallach and Gutmann,¹⁴ Golubev,¹⁵ and Schindelmeiser¹⁶ were obtained from Siberian pine needle oil. The sample of hydrocarbon examined by Hückel et al.¹⁷ was described as optically homogeneous. This is proved by its high optical

rotation as workers have reported $[\alpha]_D$ values on the optical enantiomorphs from $+52^\circ$ to $+104^\circ$, and melting points from 39° to 52° . *dl*-Products of Bertram and Walbaum,¹⁸ and Lipp¹⁹ were derived from isoborneol; those of Langlois²⁰ from ω -camphene carbonic acid, and the *l*-isomer of Brühl²¹ from *l*-bornyl chloride.

When calculated upon a temperature of 20° , the value of d would be about 0.870, and that of n_D about 1.470.

As pointed out, camphene shows a marked tendency to undergo intramolecular rearrangements. Although camphene contains an ethylenic linkage it does not react easily or smoothly with chlorine or bromine. The action of halogen acids, especially hydrochloric acid, has been discussed under "Identification." Hydration under usual conditions yields the secondary alcohol isoborneol and some borneol, an intermediate product of the hydration being the tertiary alcohol camphene hydrate m. 150° – 151° , b. 206° – 207.5° , phenylurethane m. 89° .

According to Wagner,²² the oxidation of camphene with dilute potassium permanganate yields camphene glycol $C_{10}H_{16}(OH)_2$, m. 199.5° – 200° , and several acids, among them camphenic acid $C_{10}H_{16}O_4$ (dibasic and isomeric with camphoric acid), and an α -hydroxy acid, viz., camphenylic acid, m. 170° – 172° , this acid giving on further oxidation camphenilone $C_9H_{14}O$. For details, see Simonsen's "The Terpenes," Vol. II (1932), 240.

One of the most interesting of the properties of this terpene is its tendency to form azeotropic binary mixtures with numerous compounds, which characteristic may be used to advantage in connection with identification (cf. Vol. V, Beilstein E II, 106).

Use.—Synthetic camphene and camphene-containing fractions of essential oils are quite widely used in low-priced mixtures serving for the scenting of all kinds of technical preparations.

¹ *J. prakt. Chem.* II, **49** (1894), 1.

² *Ber.* **40** (1907), 4923.

³ *Ber.* **53** (1920), 1824; **55** (1922), 2500.

⁴ *Liebigs Ann.* **382** (1911), 296; **399** (1913), 241; **402** (1914), 343.

⁵ *Ibid.* **549** (1941), 186. *Chem. Abstracts* **37** (1943), 1907.

⁶ *Compt. rend.* **180** (1925), 1832.

⁷ *Rec. trav. chim.* **46** (1927), 243.

⁸ *J. Chem. Soc.* (1926), 2775.

⁹ *Liebigs Ann.* **200** (1880), 350.

¹⁰ *Z. physik. Chem.* **76** (1911), 471.

¹¹ *Chem. Zentr.* II (1907), 1210.

¹² *Liebigs Ann.* **398** (1913), 301.

¹³ *Chem. Zentr.* II (1916), 1015. *J. pharm. chim.* [VII], **14** (1916), 97.

¹⁴ *Liebigs Ann.* **357** (1907), 80.

¹⁵ *J. Russ. Phys. Chem. Soc.* **36** (1904), 1107; **41** (1909), 1004.

¹⁶ *Ibid.* **35** (1903), 76. *Chem. Zentr.* I (1903), 835.

¹⁷ *Liebigs Ann.* **549** (1941), 186. *Chem. Abstracts* **37** (1943), 1907.

¹⁸ *J. prakt. Chem.* II, **49** (1894), 8.

¹⁹ *Liebigs Ann.* **382** (1911), 282.

²⁰ *Ann. chim.* [9], **12** (1919), 334.

²¹ *Ber.* **25** (1892), 147, 162.

²² *Ber.* **23** (1890), 2311. See Tiemann, *Ber.* **29** (1896), 124. Aschan, *Liebigs Ann.* **375** (1910), 336; **383** (1911), 52.

SUGGESTED ADDITIONAL LITERATURE

Otto Diels and Kurt Alder with Siegfried Beckmann, "Syntheses in the Hydroaromatic Series. Diene Syntheses of Anthracene. Anthracene Formula," *Liebigs Ann.* **486** (1931), 191. *Chem. Abstracts* **25** (1931), 3646.

P. Lipp and G. Stutzinger, "Racemization Phenomena with Camphene and Their Mechanism," *Ber.* **65** (1932), 241.

Morizo Ishidate, Noboru Inouye, and Hiroyuki Fukushima, "Oxidation of Camphene with Lead Tetracetate," *Bull. Chem. Soc. Japan* **17** (1942), 491. *Chem. Abstracts* **41** (1947), 4474.

Hirokichi Kumagae, "The Oxidation of Camphene," *J. Chem. Soc. Japan* **65** (1944), 337. *Chem. Abstracts* **41** (1947), 4474.

G. A. Rudakov and L. I. Gulyaeva, "Catalytic Transformation of Terpenes. Catalytic Transformations of Camphene in the Presence of Activated Clays," *J. Gen. Chem. U.S.S.R.* **16** (1946), 251. *Chem. Abstracts* **41** (1947), 114.

Walter Hückel and Hans Günter Kirschner, "Ring Expansion in the Oxidation of Camphene," *Ber.* **80** (1947), 41. *Chem. Abstracts* **41** (1947), 3078.

The Fenchenes

$C_{10}H_{16}$

Mol. Weight 136.23

The occurrence of fenchene in nature has been reported but not definitely proved, although it may be present in some essential oils. Bouchardat and Tardy¹ claimed that they isolated from oil of *Eucalyptus globulus* a terpene which, on heating with benzoic acid, yielded fenchyl alcohol. Later Austerweil² showed that α - and β -pinene, too, on heating with organic acids give fenchene and fenchene derivatives. Both α - and β -pinene on hydration yield fenchyl alcohol. It is, therefore, quite possible that the formation of fenchyl alcohol, as observed in the above-mentioned case of *Eucalyptus globulus* oil, was due to α - and β -pinene and not to fenchene.

The chemistry of fenchene and its isomers, especially their nomenclature, is quite complicated and confused. Since space does not permit a discussion, the reader is referred to the excellent account of Simonsen in his work "The Terpenes," Vol. II, page 437, Cambridge, The University Press, 1932.

It is possible to prepare from fenchone four isomeric bicyclic hydrocarbons and a tricyclic hydrocarbon:

- I. α -Fenchene (Wallach's D-*l*-fenchene or L-*d*-fenchene).
- II. β -Fenchene (Wallach's D-*d*-fenchene or L-*l*-fenchene).
- III. γ -Fenchene.
- IV. δ -Fenchene.
- V. Cyclofenchene (Aschan's β -pinolene).

The fenchenes can be prepared by three general methods, viz.:

- (a) Direct dehydration of fenchyl or isofenchyl alcohol.
- (b) Distillation of methyl fenchyl or isofenchylxanthates.
- (c) Cleavage of hydrogen chloride from fenchyl or isofenchyl chlorides.

The reactions, however, do not proceed smoothly and are accompanied by molecular rearrangement which results in the formation of several hydrocarbons. Thus it seems quite possible that none of the fenchenes has ever been obtained in pure form. According to the method of preparation, various isomers will be formed which possess different physicochemical properties.

¹ *Compt. rend.* **120** (1895), 1418.

² *Chem. Ztg.* **50** (1926), 5, 33.

I. α -Fenchene

$C_{10}H_{16}$

Mol. Weight 136.23

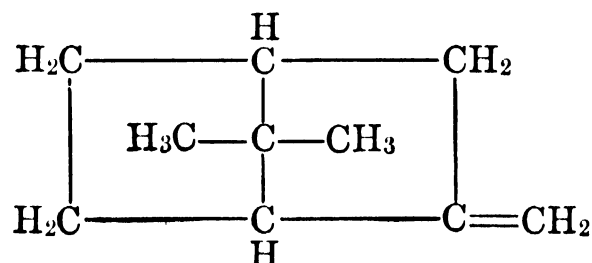

α -Fenchene is known both in the dextro- and laevorotatory forms and is probably the fenchene originally prepared by Wallach.¹

Identification.— α -Fenchene can be characterized:

(1) According to Wallach and Virck,² by the preparation of its crystalline dibromide. The *d*- and *l*- forms melt at 87° – 88° , $[\alpha]_D +42^\circ 50'$ (in ethyl acetate). The *dl*- form melts at 62° .

(2) According to Bertram and Helle,³ α -fenchene, on hydration with glacial acetic acid and sulfuric acid, yields isofenchyl acetate. The free alcohol melts at 61.5° – 62° , its phenylurethane at 106° – 107° .

Properties.— α -Fenchene possesses a camphor-like odor. The following properties have been reported:

l- α -Fenchene (prepared from *l*-fenchyl alcohol), according to Ruzicka and Liebl:⁴

b_{720}	153° – 154°	$[\alpha]_D$	$-38^\circ 0'$
d_4^{13}	0.870	n_D^{13}	1.4750

d- α -Fenchene (prepared from *d*-fenchylamine), according to Wallach and Virck:⁵

b.	155° – 156°
α_D^{14}	$+29^\circ 0'$

dl- α -Fenchene [Isopinene] (dehydration of 3,7,7-trimethyl-bicyclo-[2,2,1]-heptan-3-ol), according to Komppa and Roschier: ⁶

b.	154°–156°
d_4^{20}	0.8660
n_D^{20}	1.4705

The hydrochloride melts at 35°–37°. This product isomerizes, according to Komppa and Nyman,⁷ to the β - and γ - form when heated with potassium bisulfate for a few minutes.

Use.— α -Fenchene, as such, is not used in our industries.

¹ *Liebigs Ann.* **263** (1891), 129.

² *Ibid.* **362** (1908), 182, 190. Cf. Quist, *ibid.* **417** (1918), 299.

³ *J. prakt. Chem.* II, **61A** (1900), 293. *Ber. Schimmel & Co.*, Oct. (1898), 55; April (1900), 57.

⁴ *Helv. Chim. Acta* **6** (1923), 270.

⁵ *Liebigs Ann.* **362** (1908), 199.

⁶ *Chem. Zentr.* I (1917), 751.

⁷ *Liebigs Ann.* **543** (1940), 111.

II. β -Fenchene

$C_{10}H_{16}$

Mol. Weight 136.23

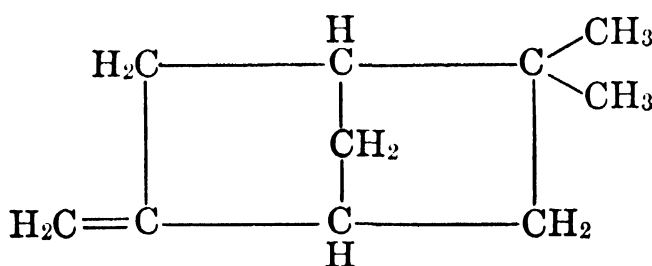

d- β -Fenchene was first prepared by Bertram and Helle ¹ by dehydration of *l*-isofenchyl alcohol.

Identification.—*d*- β -Fenchene can be characterized by the preparation of its crystalline dibromide m. 81°–82°, or its nitrosochloride m. 120°, according to Quist.²

Properties.—When prepared by the cleavage of hydrogen chloride from *l*-isofenchyl chloride with *o*-toluidine, *d*- β -fenchene had these properties according to Quist: ³

b.	150.5°–153.5°	α_D^{25}	+62° 27'
d_4^{20}	0.8599	n_D^{23}	1.4645

On hydration β -fenchene yields isofenchyl alcohol.

The racemic form has also been prepared but its purity remains questionable inasmuch as it has been derived by destructive distillation methods (Komppa and Roschier ⁴):

b.	151°–153°
d_4^{20}	0.8596
n_D^{20}	1.4658

Use.— β -Fenchene, as such, is not used in our industries.

¹ *J. prakt. Chem.* II, **61** (1900), 303.

² *Liebigs Ann.* **417** (1918), 315.

³ *Ibid.*

⁴ *Ibid.* **470** (1929), 139. *Chem. Zentr.* I (1918), 622.

III. γ -Fenchene

$C_{10}H_{16}$

Mol. Weight 136.23

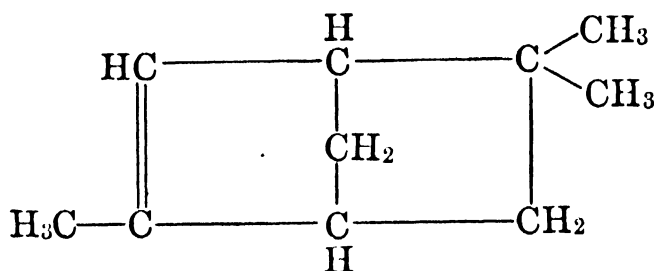

Identification.—According to Komppa and Beckmann,¹ γ -fenchene yields a nitrosochloride m. about 150° , and a nitrosate m. 146° – 147° (with decomposition).

One of the most useful derivatives for diagnosing the γ - or δ -fenchenes in mixtures is that of the phenylazide. With this reagent Alder et al.² have reported:

α -fenchene	fails to react
β -fenchene	?
γ -fenchene	adducts: I m. 148° – 149° , II m. 177°
δ -fenchene	adducts: I m. 122° , II m. 128° – 129°

Properties.—On dehydrating α -fenchyl alcohol with potassium hydrogen sulfate, a hydrocarbon fraction b. 145° – 147° , d_4^{17} 0.8547, n_D^{17} 1.46072, is obtained which contains γ -fenchene as main constituent.

Use.— γ -Fenchene, as such, is not used in our industries.

¹ *Liebigs Ann.* **503** (1933), 130.

² *Ibid.* **501** (1933), 28; **515** (1935), 177.

IV. δ -Fenchene

(Fenchylene or Isofenchene)

$C_{10}H_{16}$

Mol. Weight 136.23

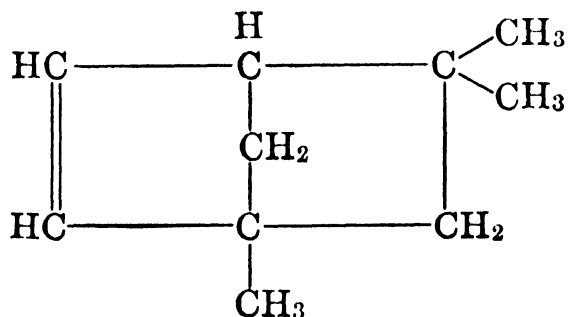

δ -Fenchene is also known as fenchylene and isofenchene. It has not been prepared in pure form.

Identification.— δ -Fenchene can be characterized by the preparation of a nitrosochloride m. 142° , and a nitrosate m. 163° . (See " γ -Fenchene" re phenylazide.)

Properties.—When obtained by the distillation of *l*-isofenchylxanthate, δ -fenchene had these properties, according to Nametkin and Ruschentzev:¹

b.	139°–140°	$[\alpha]_D$	–68° 46' (in alcohol)
d_4^{20}	0.8381	n_D^{20}	1.4494

Use.— δ -Fenchene, as such, is not used in our industries.

¹ *J. prakt. Chem.* II, **106** (1923), 35.

V. Cyclofenchene

$C_{10}H_{16}$

Mol. Weight 136.23

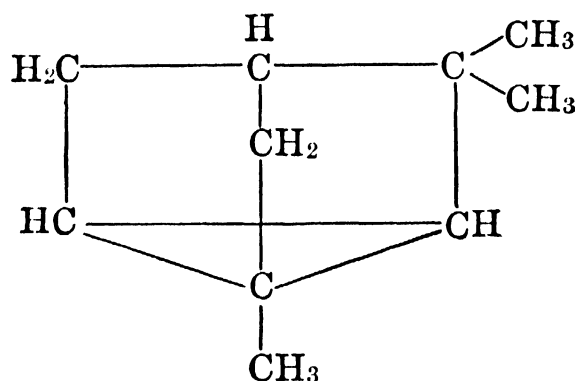

Cyclofenchene (Aschan's β -pinolene) is usually found in the lowest boiling fractions of the fenchene mixture obtained by any of the methods mentioned in the introduction to this section on fenchenes.

Identification.—When treated with bromine, cyclofenchene yields α -fenchene dibromide m. 86°–87°; with hydrogen chloride cyclofenchene forms a hydrochloride m. 26°–29° which is somewhat unstable.

Properties.—Cyclofenchene is the only one of the fenchene isomers which has been prepared in pure form because it is very slowly attacked by potassium permanganate. By shaking it with this oxidizing agent for several hours, at 60°–80°, cyclofenchene may thus be freed from unsaturated hydrocarbons.

According to Nametkin and Bryusov,¹ cyclofenchene has these properties:

b_{754}	143.0°–143.5°
d_4^{20}	0.8603
n_D^{20}	1.4515

On hydration, cyclofenchene yields isofenchyl alcohol.

Use.—Cyclofenchene, as such, is not used in our industries.

¹ *Liebigs Ann.* **459** (1927), 166. *J. Russ. Phys. Chem. Soc.* **60** (1928), 290.

SUGGESTED ADDITIONAL LITERATURE

Gust. Komppa and R. H. Roschier, "Fenchene Series. Ozonization and Constitution of the Fenchenes," *Liebigs Ann.* **470** (1929), 129. *Chem. Abstracts* **23** (1929), 3693.

Gust. Komppa and G. A. Nyman, "Fenchene Series. The Reaction Mechanism in the Dehydration of Fenchyl Alcohol," *Liebigs Ann.* **535** (1938), 252. *Chem. Abstracts* **32** (1938), 8396.

N. J. Toivonen, V. Alfthan, L. H. Böök, M. I. Erich and E. K. Heino, "Chemistry of Synthetic Diterpenes. Dimerization of Fenchene with Clay Catalysts: β -Difenchene," *J. prakt. Chem.* **159** (1941), 70. *Chem. Abstracts* **37** (1943), 4064.

W. R. Littlejohn, "The Fenchenes," *Perfumery Essential Oil Record* **39** (1948), 220.

$C_{10}H_{16}$

α -Thujene

Mol. Weight 136.23

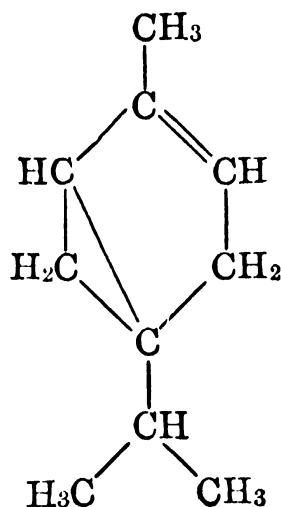

Occurrence.—According to Simonsen,¹ *d*- α -thujene is the main constituent in the terpene fraction of the oil distilled from the gum-oleoresin of *Boswellia serrata* Roxb., and in the oil from the leaves of the Formosa Hinoki tree. It has also been reported by Huzita² in orthodon oils. Birch and Earl³ proved that the "origanene" found by Birch⁴ in oil of *Eucalyptus dives* is actually a mixture of *d*- and *dl*- α -thujene.

Isolation.—By fractional distillation.

Identification.— α -Thujene may be characterized:

(1) By its low specific gravity.

(2) By its conversion into terpinene dihydrochloride through the action of hydrogen chloride.

(3) According to Wallach,⁵ and Kondakov and Skvorzov,⁶ α -thujene, on oxidation with potassium permanganate (and depending upon the conditions), yields either α -thujaketonic acid m. 75°–76° (semicarbazone m. 182°–183°, oxime m. 174°–176°), the stable *d*- α -thujadicarboxylic acid m. 141°–142°, or *d*- β -thujadicarboxylic acid m. 116°–118°. On oxidation with dilute permanganate solution and at low temperature, only α -thujaketonic acid is obtained (but this in quantitative yield).

Properties.—*d*- α -Thujene is a colorless oil possessing a somewhat sharp odor, quite different from that of α -pinene.

According to Simonsen,⁷ natural *d*- α -thujene has these properties:

b_{699}	152.0°–152.5°	$[\alpha]_D^{30}$	+37° 41'
d_{30}^{30}	0.8314	n_D^{30}	1.4502

These observations confirm the earlier findings of Tschugaev and Fomin,⁸ and Ostling.⁹

The laevorotatory form has also been derived from decomposition of certain synthetic thujyl derivatives, according to Tschugaev.¹⁰

The cyclopropane ring of α -thujene is unstable and readily undergoes fission. The action of hydrogen chloride and hydrogen bromide in acetic acid solution yields the corresponding terpinene dihalogenides. α -Thujene is only very slowly attacked by oxygen.

Use.— α -Thujene is not used in our industries.

¹ *Indian Forest Records* **9** (1923), 289.

² *J. Chem. Soc. Japan* **61** (1940), 729. *Chem. Abstracts* **36** (1942), 6753.

³ *J. Proc. Roy. Soc. N. S. Wales* **72** (1938), 55.

⁴ *Ibid.* **71** (1938), 330.

⁵ *Liebigs Ann.* **350** (1906), 166. See also Tiemann and Semmler, *Ber.* **30** (1897), 431.

⁶ *J. prakt. Chem.* II, **69** (1904), 181. See also Thomsen, *J. Chem. Soc.* **97** (1910), 511. Tschugaev, *Ber.* **37** (1904), 1484.

⁷ *Indian Forest Records* **9** (1923), 298.

⁸ *Ber.* **45** (1912), 1297.

⁹ *J. Chem. Soc.* **101** (1912), 471.

¹⁰ *Ber.* **34** (1901), 2279; **37** (1904), 1482.

$C_{10}H_{16}$

β -Thujene

Mol. Weight 136.23

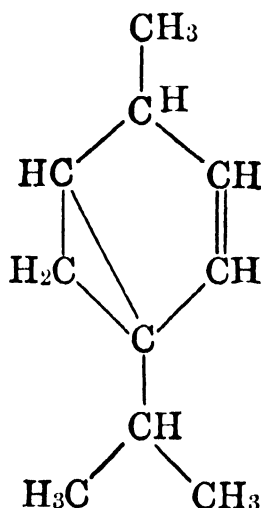

β -Thujene was described by Tschugaev,¹ and by Kondakov and Skvorzov.²

Occurrence.— β -Thujene has not yet been reported to occur in nature, but Huzita³ recently identified the α - isomer in oil of *Orthodon hirtum* Hara and 75 per cent “thujene” in *Orthodon punctulatum* Ohwi. Therefore, the presence of β -thujene in the orthodon oils seems likely.

Properties.—Tschugaev and Fomin⁴ reported these properties:

b_{739}	147°	$[\alpha]_D$	+110° 47'
d_4^{20}	0.8208	n_D^{20}	1.44708

On oxidation, β -thujene yields *dl*-homothujadicarboxylic acid $C_{10}H_{16}O_4$, m. 146°–147°.

Use.— β -Thujene is not used in our industries.

¹ Ber. **37** (1904), 1483.

² J. prakt. Chem. II, **67** (1903), 574; II, **69** (1904), 176.

³ J. Chem. Soc. Japan **61** (1940), 729; **62** (1941), 134. Chem. Abstracts **36** (1942), 6752.

⁴ Ber. **45** (1912), 1297.

Bornylene

C₁₀H₁₆

Mol. Weight 136.23

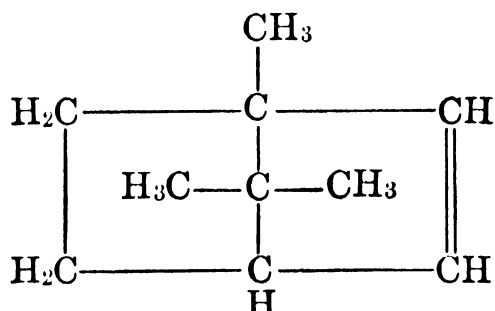

This unsaturated bicyclic hydrocarbon was prepared synthetically by Wagner and Brickner,¹ and by Tschugaev.²

Occurrence.—Bornylene does not occur in nature. However, it is an important isomerization product in diagnostic reactions of the borneols (cf. Shavrygin³ and Kharasch, Engelmann and Urry⁴).

Identification.—According to Henderson and Heilbron,⁵ bornylene can be characterized by its nitrosite m. 163°, prepared by the action of nitrous acid on bornylene.

Achmatowicz⁶ has prepared the halogen acid addition products of bornylene. These are best obtained, according to this author, by reaction of the hydrohalide with the hydrocarbon in chloroform at 0° C.

C ₁₀ H ₁₇ Cl	m. 149°–149.5°	[α] _D +15° 26'
C ₁₀ H ₁₇ Br	m. 124°–125°	[α] _D +6° 31'
C ₁₀ H ₁₇ I	m. 22°–25°	[α] _D +55° 11'

Properties.—Although crystalline, bornylene is readily volatile. The following properties have been reported:

d-Bornylene, according to McAlpine:⁷

m.	113°
b ₇₅₀	146.5° (Tschugaev and Budrick ⁸)
[α] _D ¹⁷	+23° 56' (in benzene, c = 8.23)

l-Bornylene (Bredt and Hilbing⁹)

m.	113°
b _{745.5}	146°
[α] _D ¹⁹	–23° 56' (in benzene, c = 8.23)

dl-Bornylene does not seem to have been described in literature.

Use.—Bornylene, as such, is not used in our industries.

- ¹ *Ber.* **33** (1900), 2121.
² *J. Russ. Phys. Chem. Soc.* **32** (1900), 332.
³ *J. Gen. Chem. U.S.S.R.* **10** (1940), 807.
⁴ *J. Am. Chem. Soc.* **66** (1944), 365.
⁵ *J. Chem. Soc.* **99** (1911), 1896.
⁶ *Roczniki Chem.* **8** (1928), 55.
⁷ *J. Chem. Soc.* (1932), 545.
⁸ *Liebigs Ann.* **388** (1912), 288.
⁹ *J. prakt. Chem.* [2], **84** (1911), 782.

SUGGESTED ADDITIONAL LITERATURE

Stotherd Mitchell and S. B. Cormack, "Rotation Dispersion and Circular Dichroism of Bornylene Nitrosite," *J. Chem. Soc.* (1932), 415. *Chem. Abstracts* **26** (1932), 3729.

Orthodene

$C_{10}H_{16}$ Mol. Weight 136.23

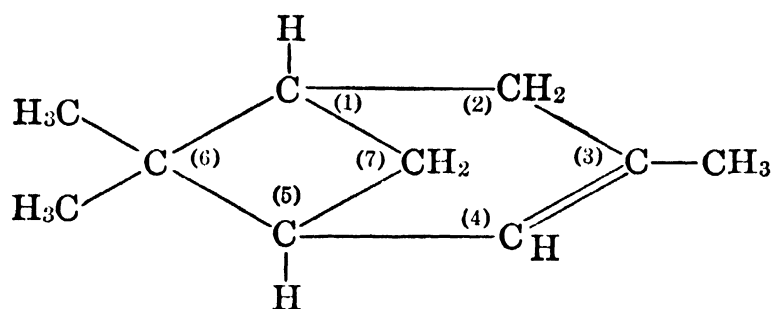

Occurrence.—Fujita¹ found that the oil distilled from the herb *Orthodon lanceolatum* Kudo (fam. *Labiatae*) contains 7 per cent of a dicyclic terpene which Fujita named orthodene.

Isolation.—By fractional distillation.

Identification.—Through its properties. Oxidation with permanganate gave a keto acid $C_{10}H_{16}O_3$ m. 129° – 130° , semicarbazone m. 116° – 118° ; further reaction with sodium hypobromite yielded bromonorpinic acid m. 76° – 77° . Guha and Rao,² in the course of investigating Fujita's acid, concluded that this product was the *cis*- compound.

Properties.—Fujita³ reported these properties of orthodene:

b_{757}	168° – 170° (corr.)	α_D^{29}	$+32^{\circ} 36'$
d_4^{30}	0.8430	n_D^{30}	1.4670

Use.—Orthodene is not used in our industries.

- ¹ *J. Chem. Soc. Japan* **54** (1933), 1181.
² *Ber.* **71** (1938), 1591.
³ *J. Chem. Soc. Japan* **54** (1933), 1184.

Camphane

 $C_{10}H_{18}$

Mol. Weight 138.24

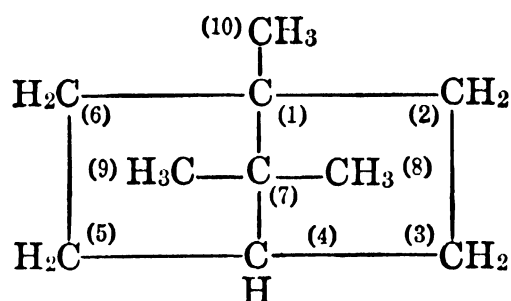

Being the parent hydrocarbon of the camphor group, this saturated bicyclic terpene merits a brief description in these pages.

Camphane has been prepared synthetically by several workers, among them Semmler,¹ Aschan,² Kishner,³ and Wolff.⁴

Occurrence.—Camphane does not occur in nature.

Properties.—Camphane possesses a faint odor similar to that of borneol, and is very volatile even at room temperature. Optically inactive, m. 156° – 157° , b. 157° – 159° (Biilmann, Jensen and Bak⁵). Camphane is extremely resistant to the action of reagents, except to dilute nitric acid at 145° – 150° whereby nitro derivatives are formed, according to Konovalov and Kikina,⁶ and Nametkin.⁷

Use.—Camphane has not found any practical use in our industries.

¹ *Ber.* **33** (1900), 777, 3424.

² *Ber.* **33** (1900), 1009; **45** (1912), 2395. *Liebigs Ann.* **316** (1901), 234.

³ *J. Russ. Phys. Chem. Soc.* **43** (1911), 582.

⁴ *Liebigs Ann.* **394** (1912), 95.

⁵ *Ber.* **69B** (1936), 1947.

⁶ *J. Russ. Phys. Chem. Soc.* **34** (1902), 935.

⁷ *Ibid.* **47** (1915), 409.

(c) SERIES OF LOWER TERPENE HOMOLOGUES.

Santene

(Norcamphene)

 C_9H_{14}

Mol. Weight 122.20

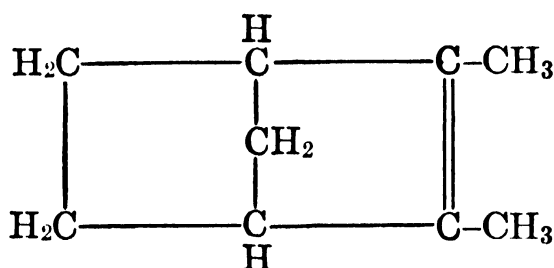

Occurrence.—Santene occurs in East Indian sandalwood oil, also in Siberian, German and Swedish pine needle oil, in the oil distilled from the needles of *Abies alba* and a few other volatile oils.

Isolation.—By fractional distillation.

Identification.—Santene can be identified, according to Müller,¹ and Aschan:²

(1) By the preparation of its α -nitrosochloride which crystallizes in the form of blue needles m. 109° – 110° . On exposure to the air the α - form passes into the colorless β - form. The latter is possibly bimolecular since, on heating to 90° , it is converted into the blue α - modification.

(2) By the preparation of the nitrosite which crystallizes in the form of blue prisms m. 123° – 126° and which, according to Deussen,³ with alcoholic potassium hydroxide yields the colorless form m. 104° .

(3) With hydrogen chloride in ethereal solution, santene forms a crystalline hydrochloride m. about 80° . On digestion with aniline, santene may be reconverted from this hydrochloride. When treated with milk of lime at 70° – 80° , the hydrochloride yields santene hydrate $C_9H_{16}O$ (see "Santene Hydrate").

(4) On treatment with bromine, santene yields a tribromide m. 62° – 63° according to Müller,⁴ but m. 77° – 78° according to Aschan⁵ who expressed the opinion that the melting point of the tribromide varies according to the origin of the santene.

(5) On careful oxidation of santene with potassium permanganate in acetone solution, Semmler and Bartelt⁶ obtained a diketone $C_9H_{14}O_2$, b_{10} 119° – 124° ; disemicarbazone m. 216° .

(6) Santene, according to Deussen,⁷ reacts with mercury salts to form characteristic derivatives. With the acetate, a hydroxy mercuric acetate m. 126° – 127° is obtained, while the iodide yields the corresponding derivative melting at 130° – 131° .

(7) Deussen⁸ reports that catalytic reduction yields a dihydro derivative boiling at 150° – 152° , $d_{18.5}$ 0.8712, $n_D^{18.6}$ 1.4636.

Properties.—Santene is an oil of somewhat unpleasant odor. It is difficult to obtain in pure form and resinifies quite readily.

Aschan,⁹ Semmler,¹⁰ Schimmel & Co.,¹¹ and Müller¹² all appear to be in good agreement on the following range of properties reported for santene:

b_{770}	140° – 141° ¹¹	α_D	$\pm 0^{\circ}$
$b.$	139° – 140° ^{12, 9}	n_D^{20}	1.46436 ¹¹
b_{15}	35° – 37° ¹²	$n_D^{19.2}$	1.46960 ⁹
b_9	31° – 33° ¹⁰	n_D	1.46878 ⁹
d_{20}	0.863 ¹⁰		1.46658 ¹⁰
d_{15}^{15}	0.869 ¹¹		
d_{15}	0.8710 ¹²		
d_4^{15}	0.8735 ⁹		

Santene is not affected by the action of alkali, but it can easily be hydrated either with acetic acid–sulfuric acid (Bertram-Walbaum method), by treatment with formic acid, or with sulfuric acid in ethereal solution. The product of hydration will be santenol $C_9H_{16}O$ (see "Santenol").

Use.—Santene as such is not used in our industries.

¹ *Arch. Pharm.* **238** (1900), 369, 380.

² *Ber.* **40** (1907), 4920.

³ *J. prakt. Chem.* **114** (1926), 116.

- ⁴ *Arch. Pharm.* **238** (1900), 372.
⁵ *Ber.* **40** (1907), 4920.
⁶ *Ber.* **41** (1908), 128. Cf. Semmler, *Ber.* **40** (1907), 4596.
⁷ *J. prakt. Chem.* **114** (1926), 112, 114.
⁸ *Ibid.*
⁹ *Oversikt Finska Vetenskaps-Soc. Förh.* **53A**, 8 (1910–11), 5.
¹⁰ *Ber.* **40** (1907), 4595.
¹¹ *Ber. Schimmel & Co.*, Oct. (1910), 98.
¹² *Arch. Pharm.* **238** (1900), 369, 380.

D. SESQUITERPENES

Introduction.—Many essential oils contain in the fractions b. 250°–280° hydrocarbons of the empirical molecular formula C₁₅H₂₄ which have been named sesquiterpenes. Hundreds of sesquiterpenes are described in literature but only in the case of relatively few has it been possible to declare them homogeneous substances and to identify them by derivatives. Being unsaturated hydrocarbons, the sesquiterpenes form halogen compounds, hydrogen halides, nitrosochlorides, nitrosites and nitrosates, some of them crystalline and therefore helpful in the identification of the parent sesquiterpene. Most of these hydrocarbons are of faint odor, more viscous than the terpenes, sparingly soluble in alcohol, b. 250°–280°, d 0.84–0.93 (usually above 0.90). Like the terpenes C₁₀H₁₆, they resinify quite readily.

Semmler,¹ and Schreiner and Kremers² classified the sesquiterpenes into four main groups, each group characterized by considerable constancy in the specific gravity of its members.

	d_{15}	n_D^{15}	$[R_L]_D$
Acyclic (four ethylenic linkages)	0.84	1.53	69.5
Monocyclic (three ethylenic linkages)	0.89–0.87	1.51–1.49	67.8
Bicyclic (two ethylenic linkages)	0.92–0.90	1.51–1.50	66.1
Tricyclic (one ethylenic linkage)	0.935–0.91	1.50–1.49	64.4

The first general formula for the sesquiterpenes was advanced by Wallach³ who suggested that a sesquiterpene molecule is composed of three isoprene nuclei, but real progress in the chemistry of the sesquiterpenes was made only about twenty-five years ago when Ruzicka and collaborators⁴ provided an experimental basis for work on the elucidation of the structure of the sesquiterpenes. In the course of their investigations Ruzicka and Meyer⁵ were able to show that cadinene, on dehydrogenation with sulfur, yields a naphthalene hydrocarbon, viz., cadalene (1,6-dimethyl-4-isopropyl-naphthalene). The same is true of calamene, zingiberene, isozingiberene, and a few other sesquiterpenes. Ruzicka, Meyer and Mingazzini⁶ proved that selinene on dehydrogenation with sulfur yields another naphthalene hydrocarbon, viz., eudalene (1-methyl-7-isopropyl-naphthalene). The same is true of eudesmol,

eudesmene, and a few other sesquiterpenes. These reactions take place according to the following equation:

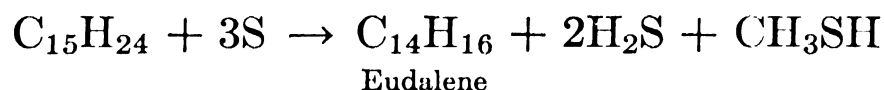
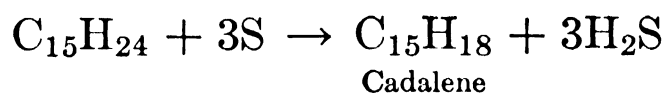

The formation of eudalene thus entails the cleavage of one methyl group from the parent sesquiterpene molecule.

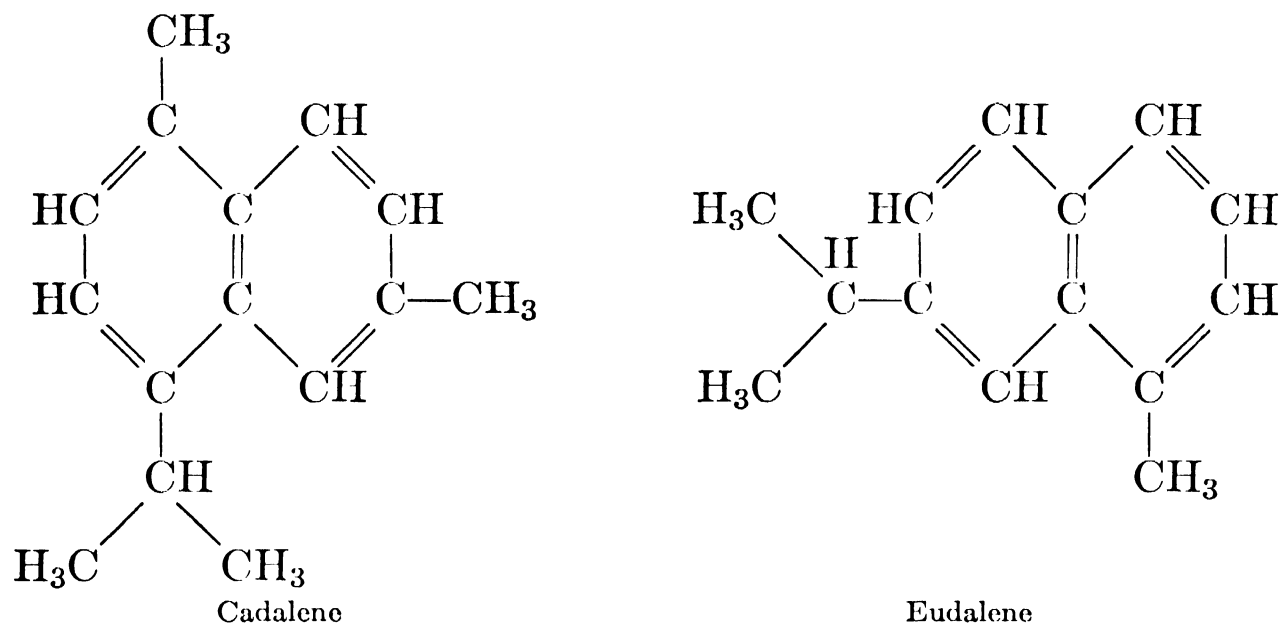

These two naphthalene hydrocarbons have the following properties:

	<i>b.</i>	<i>d</i>	<i>n_D</i>	Mol. Refr.
Cadalene	b_{720} 291°–292°	d_4^{19} 0.9792	n_D^{19} 1.5851	67.7
Eudalene	b_{720} 280°–281°	d_4^{17} 0.9734	n_D^{17} 1.5847	63.31

Both cadalene and eudalene can be characterized by the preparation of crystalline addition compounds: picrates may be prepared by adding the naphthalene hydrocarbon to a hot saturated alcoholic solution of 1 mol of picric acid. Styphnates precipitate in the form of yellow needles if an alcoholic solution of 1 mol of trinitroresorcinol is added to the naphthalene hydrocarbon.

Cadalene picrate	m. 115°
Eudalene picrate	m. 90°–91°
Cadalene styphnate	m. 138°
Eudalene styphnate	m. 119°–120°

Cadalene and eudalene are the only naphthalene hydrocarbons obtained by dehydrogenation of sesquiterpenes and sesquiterpene derivatives. This reaction, however, does not represent a general method of determining the ring structure of the sesquiterpenes. It is of limited use with monocyclic

and bicyclic sesquiterpenes, and useless with tricyclic sesquiterpenes and sesquiterpene derivatives. In these cases other methods have to be resorted to in order to determine the ring structure of the parent sesquiterpene.

¹ *Ber.* **36** (1903), 1037.

² "The Sesquiterpenes," Milwaukee, 1904. Cf. Simonsen, "The Terpenes," Vol. II (1932), 486.

³ *Liebigs Ann.* **238** (1887), 78; **239** (1887), 49.

⁴ See Ruzicka, "Über Konstitution und Zusammenhänge in der Sesquiterpenreihe" (1928).

⁵ *Helv. Chim. Acta* **4** (1921), 505, 508.

⁶ *Ibid.* **5** (1922), 345, 363.

SUGGESTED ADDITIONAL LITERATURE

Pl. A. Plattner, A. Fürst und K. Jirasek, "Zur Kenntnis der Sesquiterpene. Über das Bicyclo-[0,3,5]-decan," *Helv. Chim. Acta* **29** (1946), 730.

Pl. A. Plattner, A. Fürst, and J. Hellerbach, "Sesquiterpenes. The Stereochemistry of 1,3-Dimethyl-2-Cyclohexanols," *Helv. Chim. Acta* **30** (1947), 100 (in German). *Chem. Abstracts* **41** (1947), 3768.

(a) ALIPHATIC SESQUITERPENES.

Sesquicitronellene

C₁₅H₂₄

Mol. Weight 204.34

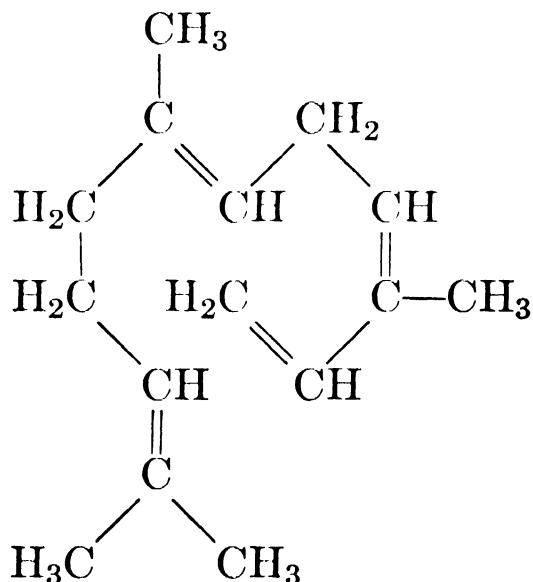

Sesquicitronellene is an acyclic sesquiterpene containing four ethylenic linkages. This type of structure suggests the hydrocarbon to be one of the four possible geometric isomers of the farnesenes.

Occurrence.—In the sesquiterpene fraction of Java and Ceylon citronella oil, according to Schimmel & Co.,¹ and Semmler and Spornitz.²

Isolation.—The fraction b. 268°–270° of Java citronella oil is extracted several times with 60–70% alcohol (in order to remove the isoeugenol), and repeatedly fractionated over metallic sodium at reduced pressure.

Identification.—Reduction with sodium and alcohol yields dihydrosesquicitronellene C₁₅H₂₆, b₁₂ 131°–133°, d₂₀ 0.8316, α_D ±0°, n_D 1.4800.

Although the original workers did not prepare further derivatives of this dihydro compound, subsequent investigators have obtained dihydrogenated farnesenes that yield characteristic derivatives. Jones and Haenke³ obtained a hexabromide m. 131° from the dihydrofarnesene isolated from the nerolidol fraction in Queensland oils, whereas Farmer and Sutton⁴ obtained a trihydrochloride salt m. 52° from a synthetic dihydrofarnesene. However, this hydrocarbon did not yield a crystallizable bromide. The physical properties of the dihydrofarnesenes thus far isolated do not agree with those observed by Semmler and Spornitz. However, the two types of derivatives, i.e., the hexabromide and trihydrochloride, are recommended for diagnostic purposes in the case of sesquicitronellene.

Properties.—The following properties have been reported by Semmler and Spornitz:

b_g	138°–140°	$[\alpha]_D$	+0° 36'
d_{20}	0.8489	n_D	1.53252

On digestion with concentrated formic acid, sesquicitronellene yields a monocyclic compound b_{15} 129°–132°, d_{20} 0.8892, α_D +56° 0', n_D 1.5069, which should consist mainly of bisabolene, if sesquicitronellene is actually identical with farnesene. However, literature does not mention that a crystalline trihydrochloride was prepared.

Use.—Sesquicitronellene, as such, is not used in our industries except as part of certain high boiling citronella oil fractions which serve as fixatives in the scenting of soaps and technical preparations.

¹ *Ber. Schimmel & Co.*, Oct. (1899), 19.

² *Ber.* **46** (1913), 4025.

³ *Proc. Roy. Soc. Queensland* **48** (1937), 44.

⁴ *J. Chem. Soc.* (1942), 116.

(b) MONOCYCLIC SESQUITERPENES.

Bisabolene

(Limene)

$C_{15}H_{24}$

Mol. Weight 204.34

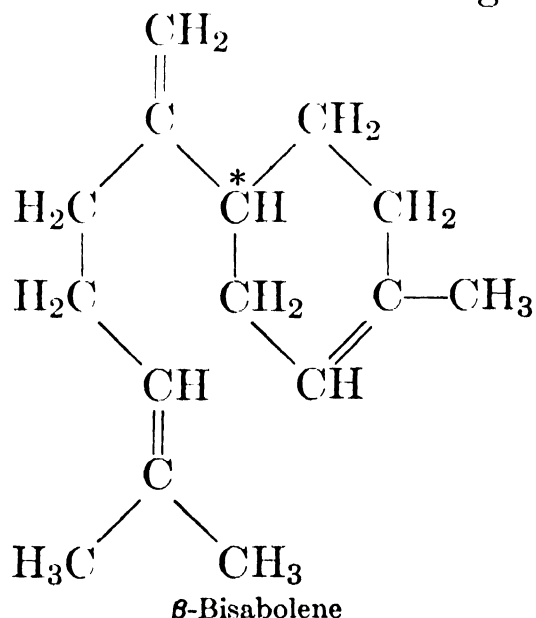
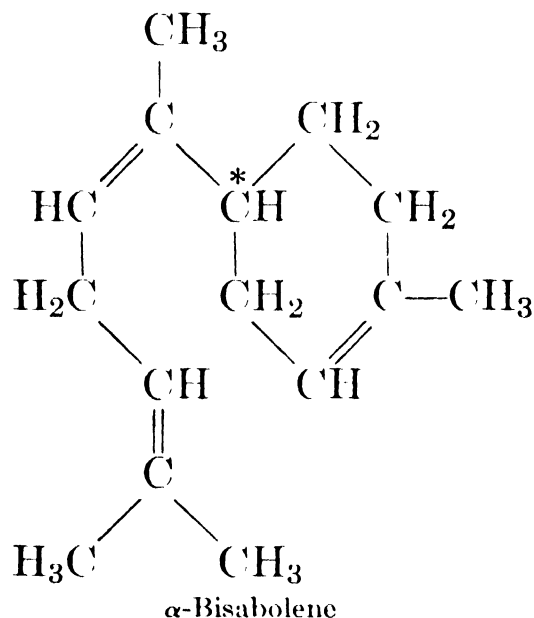

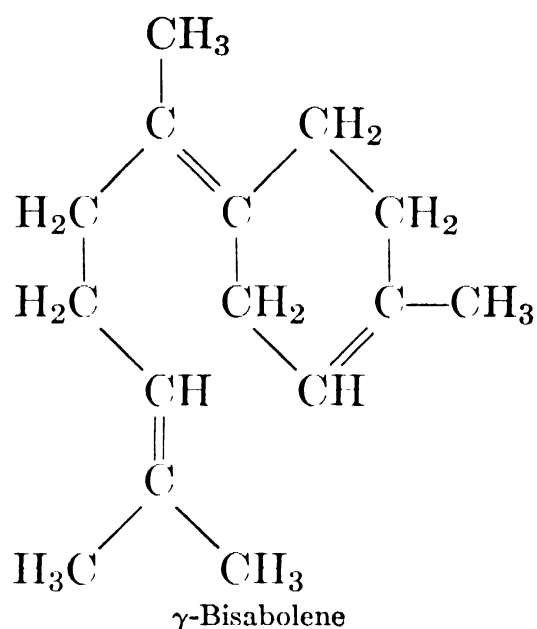

According to Ruzicka and van Veen,¹ this monocyclic sesquiterpene containing three ethylenic linkages consists of a mixture of three isomers—viz., α -, β - and γ -bisabolene, the latter largely predominating. All three isomers can be transformed into the same trihydrochloride. This applies to the natural as well as to the synthetic bisabolene.

Occurrence.—Bisabolene occurs widely distributed in nature. It is present in oil of Bisabol myrrh (opopanax), lemon, lime, bergamot, camphor, in Siberian pine needle oil, Chinese star anise, cardamom, sandalwood oil, etc.

Isolation.—Bisabolene can be isolated from Bisabol myrrh oil, for example, by fractionation, by twice redistilling the fraction b_{12} 110° – 140° over metallic sodium, and by converting the sesquiterpene in ethereal solution into its trihydrochloride $C_{15}H_{24} \cdot 3HCl$. On boiling with sodium acetate and glacial acetic acid, the trihydrochloride is decomposed and the bisabolene regenerated.

Jackson and Short² have found in certain instances, as in star anise oil, that the oxygenated compounds are eliminated only by treatment with metallic potassium and that careful recrystallization of the trihydrochloride is necessary to eliminate cadinene which occurs with the bisabolene.

Identification.—Bisabolene can be characterized by the preparation of several derivatives:

(1) The trihydrochloride m. 79° – 80° (recrystallized in alcohol) is most conveniently obtained by passing gaseous hydrogen chloride into an ethereal solution of the sesquiterpene.

(2) The trihydrobromide melts at 84° , according to Wallach.³

(3) The hexabromide melts at 154° , according to Schmidt and Weilingner.⁴ It is prepared with bromine in the presence of sodium acetate and acetic acid and purified from acetone. Asahina and Tsukamoto⁵ also isolated two other isomers from this same reaction, m. 142° and 130° – 132° .

Properties.—Bisabolene is a colorless viscid oil.

When regenerated from its trihydrochloride, bisabolene has these characteristic properties, according to Gildemeister and Müller,⁶ and Ruzicka and Capato:⁷

b ₇₅₁	261°–262° ⁶	α_D	$\pm 0^\circ$ ⁶
b ₁₂	133°–134° ⁷	n _D ²¹	1.4923 ⁷
d ₄ ²¹	0.8717 ⁷	n _D ²⁰	1.4901 ⁶
d ₁₅ ¹⁵	0.8759 ⁶		

Several bisabolene fractions of varying optical activity have thus far been isolated. The rotatory power displayed by the regenerated bisabolenes is regarded by Jackson and Short⁸ as a measure of the content of α - and β -isomers. The γ -product, believed to predominate in nature, is inactive, whereas that of the original isolate may be to a degree a function of contaminants.

Gildemeister and Müller⁹ reported a *laevo-bisabolene* fractionated from lemon oil:

b ₄	110°–112°	α_D	–41° 31'
d ₁₅ ¹⁵	0.8813	n _D ²⁰	1.49015

The trihydrochloride therefrom and the bisabolene regenerated from this product, however, were found to be optically inactive. On the other hand, Short et al.¹⁰ isolated a dextrorotatory sesquiterpene fraction ($[\alpha]_D +7^\circ 16'$ to $+9^\circ 53'$) from star anise oil that yielded an inactive trihydrochloride and yet regenerated a laevorotatory bisabolene with these properties:

b ₁₂	138.5°–139.5° (corr.)	$[\alpha]_D^{18}$	–14° 56'
d ₄ ²⁴	0.8727	n _D ²⁴	1.4937

On dehydrogenation with sulfur, bisabolene does not yield a naphthalene derivative. By heating of this reaction product with sodium dichromate and sulfuric acid, Ruzicka and van Veen¹¹ obtained terephthalic acid.

Use.—Bisabolene, as such, is not used in our industries.

¹ *Liebigs Ann.* **468** (1929), 133, 143.

² *J. Soc. Chem. Ind.* **55** (1936), 8T

³ *Liebigs Ann.* **368** (1909), 20.

⁴ *Ber.* **39** (1906), 657.

⁵ *J. Pharm. Soc. Japan* **46** (1926), 98. *Chem. Zentr.* I (1927), 1843.

⁶ *Ber. Schimmel & Co.*, Oct. (1909), 50. *Wallach Festschrift*, Göttingen (1909), 448.

⁷ *Helv. Chim. Acta* **8** (1925), 274.

⁸ *J. Soc. Chem. Ind.* **55** (1936), 8T.

⁹ *Ber. Schimmel & Co.*, Oct. (1909), 50. *Wallach Festschrift*, Göttingen (1909), 448.

¹⁰ *J. Soc. Chem. Ind.* **50** (1931), 410T; **55** (1936), 8T.

¹¹ *Liebigs Ann.* **468** (1929), 136, 137.

SUGGESTED ADDITIONAL LITERATURE

L. Ruzicka and M. Liguori, "Polyterpenes and Polyterpenoids. A New Synthesis of Bisabolenes," *Helv. Chim. Acta* **15** (1932), 3. *Chem. Abstracts* **26** (1932), 4592.

Zingiberene

C₁₅H₂₄

Mol. Weight 204.34

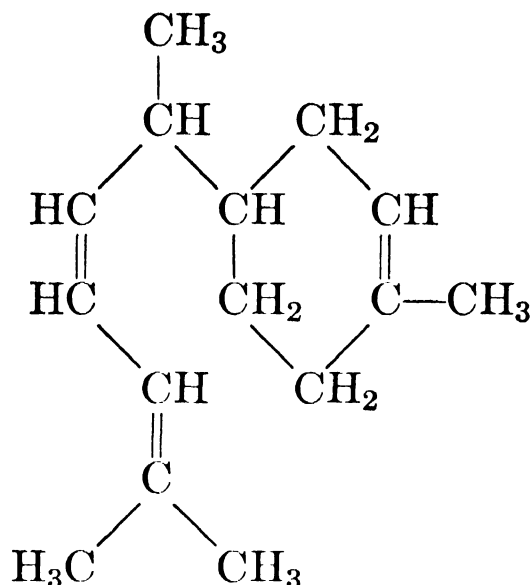

We owe our knowledge of the constitution of this monocyclic sesquiterpene chiefly to the work of Ruzicka and van Veen.¹ The natural hydrocarbon isolated from oil of ginger root is actually a mixture of zingiberene and some bisabolene; nevertheless, in this description the name zingiberene will be retained for the natural product. More recently, Soffer et al.,² studying the structural formula of isozingiberene in connection with that of cadinene, arrived at the conclusion that zingiberene possesses the configuration pictured above, and not that originally proposed by Ruzicka and van Veen.

Occurrence.—Zingiberene is the main constituent of ginger root oil (*Zingiber officinale* Roscoe). The hydrocarbon has also been identified in the oil from the roots of the *Curcuma Zedoaria* Rosc. by Rao, Shintre and Simonsen.³

Isolation.—By fractional distillation *in vacuo*.

Identification.—Zingiberene can be characterized by several methods: (1) Most conveniently by conducting gaseous hydrogen chloride into an ethereal solution of zingiberene whereby isozingiberene dihydrochloride m. 169°–170° is formed. Removing hydrogen chloride, Semmler and Becker⁴ obtained a bicyclic hydrocarbon, viz., isozingiberene b₈ 120°–123°, d₂₀ 0.9150, [α]_D –41° 0', n_D 1.5034. Zingiberene and isozingiberene are isomers.

(2) When treated with hydrogen bromide, zingiberene yields a dihydrobromide m. 175°, which, like the dihydrochloride, is a derivative of isozingiberene.

(3) According to Schreiner and Kremers,⁵ the nitrosochloride of zingiberene melts at 96°–97°. It is prepared by dissolving zingiberene in an equal volume of glacial acetic ether and ethyl nitrite, and by slowly adding a solution of hydrogen chloride in glacial acetic acid.

(4) The nitrosite of zingiberene melts at 97°–98°. However, Schreiner and Kremers⁶ reported separation of the nitrosite as it occurs in two forms, one melting at 120°–121°, and the other at 105°. The nitrosite is prepared by the interaction of zingiberene, sodium nitrite, and glacial acetic acid in petroleum ether.

(5) The nitrosate of zingiberene, according to the same authors, melts at 86°–88° (with decomposition). It is prepared from zingiberene ethyl nitrite and nitric acid in glacial acetic acid solution.

(6) Semmler and Becker ⁷ found that on reduction with sodium in alcoholic solution, zingiberene yields monocyclic dihydrozingiberene b_7 122°–125°, whereas reduction with platinum and hydrogen yields monocyclic hexahydrozingiberene b_{11} 128°–130°.

Properties.—Zingiberene is a colorless oil which tends to resinify, especially on storing.

The following properties have been reported by Schreiner and Kremers,⁸ Ruzicka, Meyer and Mingazzini,⁹ Semmler and Becker,¹⁰ and Moudgill:¹¹

b.	about 270° (with decomposition) ⁸	α_D	–60° 0' ⁹
b_{32}	160°–161° ⁸	$[\alpha]_D$	–73° 22' ⁸
b_{17}	137°–139° ⁹	$[\alpha]_D^{30}$	–73° 42' ¹¹
b_9	128°–129° ¹⁰	n_D	1.49399 ⁸
d_{30}	0.8690 ¹¹		1.49560 ¹⁰
d_{20}	0.8684 ¹⁰	n_D^{30}	1.4916 ¹¹
	0.8731 ⁸	n_D^{16}	1.4984 ⁹
d_4^{16}	0.8733 ⁹	$[R_L]_D$	68.37 ($C_{15}H_{24}F_3 = 67.86$)

These properties point toward a monocyclic terpene containing three ethylenic linkages, two of which are conjugated. This conclusion is borne out by the large molecular exaltation.

Contrary to bisabolene, zingiberene on dehydrogenation with sulfur gives cadalene in very good yield.

Use.—Zingiberene, as such, is not used in our industries.

¹ *Liebigs Ann.* **468** (1929), 143.

² *J. Am. Chem. Soc.* **66** (1944), 1520.

³ *J. Soc. Chem. Ind.* **47** (1928), 171T.

⁴ *Ber.* **46** (1913), 1818.

⁵ *Pharm. Arch.* **4** (1901), 63, 141, 161. Cf. Simonsen, "The Terpenes," Vol. II (1932), 498.

⁶ *Ibid.*

⁷ *Ber.* **46** (1913), 1814.

⁸ *Pharm. Arch.* **4** (1901), 63. *Ber. Schimmel & Co.*, Oct. (1901), 29.

⁹ *Helv. Chim. Acta* **5** (1922), 359.

¹⁰ *Ber.* **46** (1913), 1814.

¹¹ *J. Indian Chem. Soc.* **5** (1928), 255.

The Curcumenes

C₁₅H₂₂

Mol. Weight 202.33

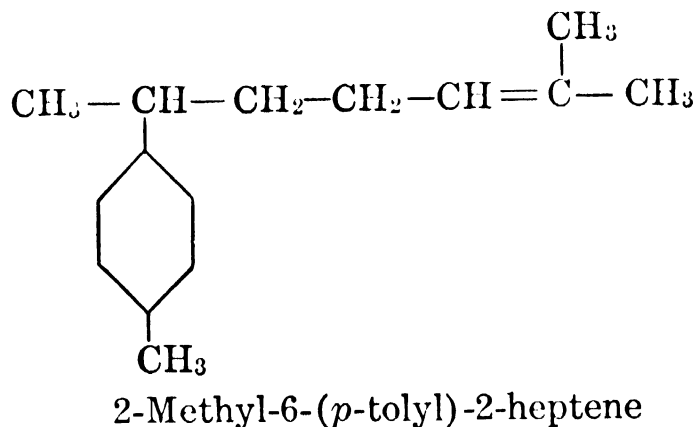
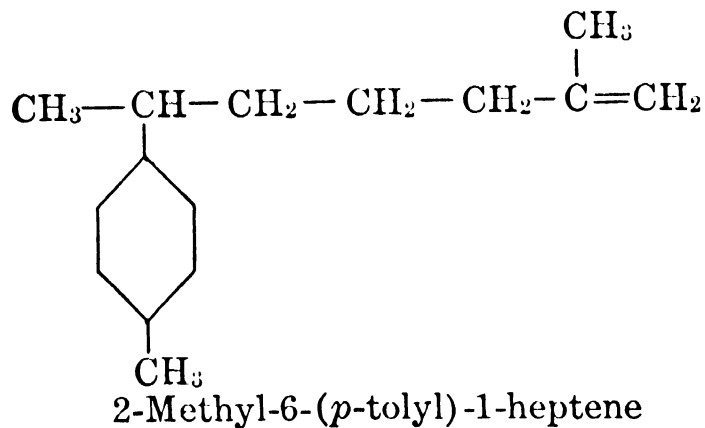

Occurrence.—The oil occurring in the root (rhizome) of *Curcuma aromatica* Salisb. contains a mixture of sesquiterpenes b_6 127°–129°, d_{30}^{30} 0.8760–0.8764, $[\alpha]_D^{30}$ –19° 24' to –25° 54', n_D^{30} 1.4929–1.4940. According to the early work of Rao and Simonsen,¹ this isolate was described as a mixture of two monocyclic hydrocarbons C₁₅H₂₄, viz., *l*- α - and *l*- β -curcumene. This continued to be the status of our knowledge relative to this terpenic product even as late as 1927 when Guttenberg² isolated the product and characterized it. However, Simonsen and co-workers³ later completed the investigation of the curcumenes, establishing their structure both by degradation and synthesis of the racemic form. Their investigation confirmed the view that the formula of the olefins contained in the natural isolate should be that delineated above.

Isolation.—It was not until recently that the isolation of this olefin was satisfactorily carried out through fractional distillation. However, the most satisfactory method is that of Simonsen et al.,⁴ by purification through crystalline derivatives. Fractional distillation can also be employed.

Identification.—The original sesquiterpene yielded a nitrosate m. 101°, a nitrobenzylamine m. 102°–104°, and, when treated with hydrogen chloride in acetic acid solution, a liquid monohydrochloride b_8 150°–155° and a crystalline trihydrochloride m. 84°–85°. On treatment with sodium acetate in acetic acid solution, the liquid monohydrochloride gives *l*- α -curcumene, while the crystalline trihydrochloride yields *l*- β -curcumene.

In addition to the above characteristics, Carter, Simonsen and Williams ⁵ reported in more recent investigations on this olefin that the nitrosate of the *dl* isomer melts at 114° with decomposition.

Properties.—Based upon isolates from the decomposition of the hydrochloride, a very pure sample of the *l*- α -curcumene is reported by Carter, Copp, Rao, Simonsen and Subramaniam; ⁶ it has the properties shown in the following tabulation. These same authors have likewise studied the *l*- β -curcumene obtained from the decomposition of the trihydrochloride salt, whereas Carter, Simonsen and Williams ⁷ published the properties of the racemic form also listed tabularly below:

	<i>l</i> - α -Curcumene	<i>l</i> - β -Curcumene	<i>dl</i> -Curcumene
b ₁₉	...	142°	...
b ₁₇	137°
b ₁₆	134°
d ₂₅ ²⁵	...	0.8670	...
d ₂₀ ^{20.6}	0.8802
d ₂₀ ²⁰	0.8821
[α] ₅₄₆₁	-34° 18'	-48° 12'	...
n _D ²⁰	1.4989	1.491	1.5002

Titration with per-benzoic acid in chloroform serve very satisfactorily to indicate the presence of one very active double bond. Hydrogenation of the other unsaturated linkages in the aromatic nuclei have been found to proceed very slowly even with palladium catalysts.

Use.—Curcumene is not used in our industries.

¹ *J. Chem. Soc.* (1928), 2496.

² *Z. ges. exptl. Med.* **54** (1927), 642. *Chem. Abstracts* **22** (1928), 4174.

³ *J. Chem. Soc.* (1939), 1504; (1940), 451.

⁴ *Ibid.*

⁵ *Ibid.* (1940), 451.

⁶ *Ibid.* (1939), 1504.

⁷ *Ibid.* (1940), 451.

(c) BICYCLIC SESQUITERPENES.

~ Cadinene

$C_{15}H_{24}$

Mol. Weight 204.34

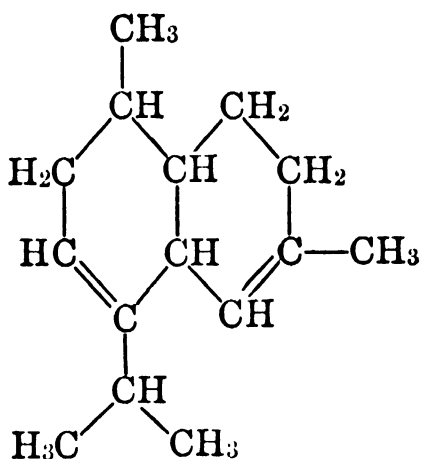

Ruzicka's α -Cadinene

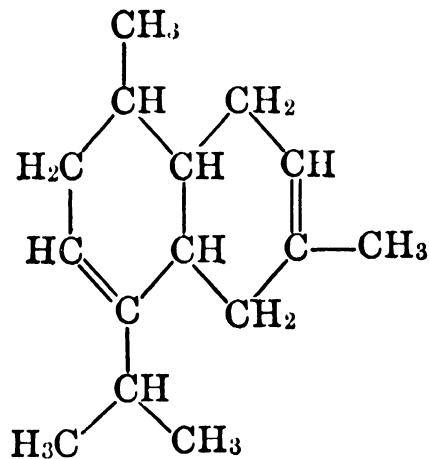

Ruzicka's β -Cadinene
= Isozingiberene,
according to Soffer

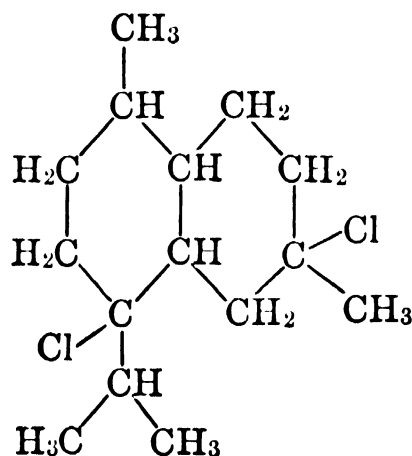

Cadinene dihydrochloride, according to Ruzicka, but Isozingiberene dihydrochloride, according to Soffer

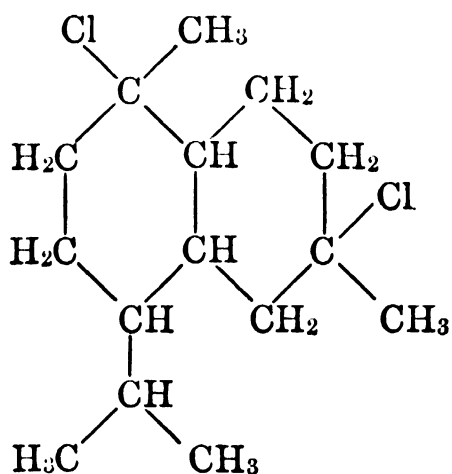

Cadinene dihydrochloride,
according to Soffer

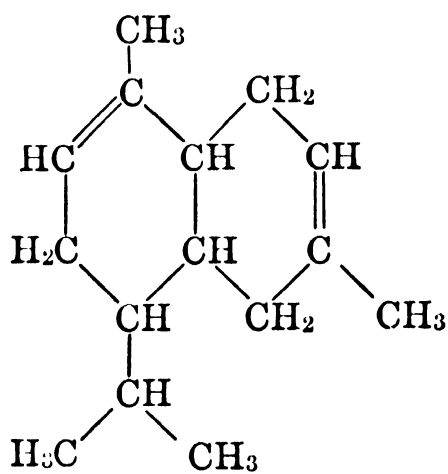

Cadinene, according to
Campbell and Soffer

Ruzicka and Stoll¹ expressed the opinion that the naturally occurring cadinene and the cadinene regenerated from its dihydrochloride have either one of the two structural formulas pictured above or that cadinene is a mixture of these two isomers which these authors named α - and β -cadinene. Later Kimura and Mizoshita² advanced a second formula for this sesquiterpene. More recently Soffer and collaborators³ showed that Ruzicka's formula for

β -cadinene is actually that of another sesquiterpene, viz., isozingiberene, and that Ruzicka's formula for cadinene dihydrochloride represents the structure of isozingiberene dihydrochloride. Campbell and Soffer⁴ proved that the ethylenic linkages of cadinene are in the 1,2 and 6,7 positions.

Several sesquiterpenes occurring in nature have been regarded as optically active forms of cadinene. The rotatory power of cadinene varies greatly in different products. It is, however, by no means certain whether those sesquiterpenes were actually cadinene, or whether they were transformed into cadinene derivatives by the action of hydrochloric acid as, for example, the sesquiterpenes occurring in West Indian sandalwood oil or in African copaiba balsam oil. The tricyclic dextrorotatory sesquiterpene copaene contained in this oil, on treatment with hydrochloric acid, is converted into laevorotatory cadinene dihydrochloride. On the other hand, the dextrorotatory sesquiterpene present in Atlas cedarwood oil yields derivatives of *d*-cadinene when treated with hydrochloric acid.

Occurrence.—Cadinene is one of the most widely distributed sesquiterpenes.

d-Cadinene occurs in Atlas cedarwood oil, probably in West Indian sandalwood oil, in oil from wood of *Juniperus oxycedrus*, etc.

l-Cadinene is found in oil of cade (hence the name cadinene), cypress, cubeb, etc.

In a great many cases, literature gives no indication as to the optical rotation. Thus, cadinene has been found in oil of cedarwood, cedar leaves, *Pinus pumilio*, juniper berries, savin, pepper, camphor, lemongrass, ylang ylang, olibanum, patchouly, galbanum, etc.

Isolation.—Cadinene may be obtained in pure form by the preparation of its dihydrochloride from which the parent sesquiterpene may be regenerated either by the action of aniline, according to Wallach,⁵ or with sodium ethylate, according to Henderson and Robertson.⁶

For this purpose, the essential oil is fractionated *in vacuo*, and the fraction b_{12} 125°–140° diluted with one-third its volume of glacial acetic acid and treated with a current of gaseous hydrogen chloride. The cadinene dihydrochloride m. 118°–118.5° so obtained is decomposed as described above.

Lepeschkin⁷ suggested that cadinene be prepared in pure form by decomposing the dihydrochloride with sodium ethylate and not with sodium acetate in boiling glacial acetic acid solution, as this treatment would yield also the isomeric isocadinene.

Identification.—Wallach⁸ suggested a simple color reaction that may indicate the presence of cadinene.

Dissolve cadinene in excess chloroform or glacial acetic acid; add a few drops of concentrated sulfuric acid; and shake the test tube. The solution will first be intensely green, later blue, and red on warming.

A determination of the physical properties, too, may be helpful, but for definite identification it is advisable to prepare derivatives of cadinene:

(1) The nitrosate melts at 105°–110°, according to Schreiner and Kremers.⁹

(2) The nitrosochloride, according to the same authors, melts at 93°–94°.

(3) An important derivative, serving for both the isolation and characterization of cadinene is its dihydrochloride m. 118°–118.5°. In order to prepare this compound,

Gildemeister and Hoffmann¹⁰ suggested diluting the fractions b. 260°–280° with twice their volume of ether, and saturating them at low temperature with a current of hydrogen chloride. After prolonged standing, the ether is partly distilled off and partly allowed to evaporate. The crystals of dihydrochloride thus obtained are dried on porous plates, washed with alcohol to remove oily impurities, and recrystallized from ether in which they readily dissolve on heating. The pure compound is optically active $[\alpha]_{\text{D}} -37^{\circ} 27'$ (in 5% chloroform solution).

The dihydrochloride can also be prepared with the aid of glacial acetic acid which has been saturated with hydrogen chloride. This modification will be particularly adapted to the preparation of the dihydrobromide and the dihydroiodide. The glacial acetic acid solution of the halogen acid is added to the glacial acetic acid solution of the sesquiterpene.

It should be kept in mind that not only cadinene but other structurally related sesquiterpenes, too, on treatment with hydrochloric acid may yield cadinene dihydrochloride.

(4) The dihydrobromide melts at 124°–125°, $[\alpha]_{\text{D}} -36^{\circ} 8'$.

(5) Dihydroiodide m. 105°–106°, $[\alpha]_{\text{D}} -48^{\circ} 0'$.

Properties.—Cadinene is a colorless, somewhat viscid oil. The following characteristic properties have been reported for this sesquiterpene:

d-Cadinene

(a) From West Indian sandalwood oil, according to Deussen.¹¹

b_{13}	138°–140°	α_{D}	+38° 43'
$d_{16.5}$	0.9260	$n_{\text{D}}^{16.5}$	1.50934

(b) From Atlas cedarwood oil, according to Grimal¹² (regenerated from the dihydrochloride):

b.	273°–275°	$[\alpha]_{\text{D}}^{20}$	+48° 7'
d_{15}	0.9224	n_{D}^{20}	1.5107

(c) From cubeb oil, according to Wallach¹³ (regenerated from the dihydrochloride): b. 274°–275°.

(d) From the oil of the wood of *Juniperus oxycedrus* by Mousseron, Granger and Ronayroux¹⁴ (separated by distillation at reduced pressure):

b_{20}	144°	$[\alpha]_{579}$	+68° 39'
d_{25}	0.9186	$[\alpha]_{546}$	+80° 23'
		n_{D}^{25}	1.5136

l-Cadinene (regenerated from the dihydrochloride):

(a) From cubeb oil, according to Henderson and Robertson:¹⁵

b_{11}	134°–136°	$[\alpha]_{5461}^{18}$	–125° 12'
d_4^{20}	0.9189	n_{D}^{20}	1.5079

(b) From various oils, according to Wallach: ¹⁶

b.	274°–275°	$[\alpha]_D$	–98° 34'
d_{20}	0.918	n_D	1.50647

As can be seen, the optical rotation of cadinene varies greatly with the different products.

(c) From cade oil (regenerated from the dihydrochloride), according to Campbell and Soffer: ¹⁷

b_{11}	136°–138°	$[\alpha]_D^{25}$	–113° 0'
d_4^{20}	0.9199	n_D^{20}	1.5071

(d) From the oil of *Ocimum gratissimum* (Madagascar and Comoro Islands) isolated by rectification over metallic sodium, according to Chiris: ¹⁸

b_{12}	123°–125°	α_D	–133° 12'
d_{15}	0.902	n_D^{16}	1.5100

Cadinene is a very stable sesquiterpene. It cannot be reduced with sodium in alcoholic solution. Cadinene reacts readily with halogens but does not seem to yield any crystalline derivatives. On dehydrogenation with sulfur, cadinene gives cadalene.

Ruzicka and Stoll ¹⁹ found that cadinene is not altered when digested with a 10 per cent solution of sulfuric acid in alcohol but, when treated with the Bertram-Walbaum mixture (glacial acetic acid + sulfuric acid), cadinene is isomerized to isocadinene.

Kafuku, Ikeda and Fujita ²⁰ investigated the high boiling fractions of Java-type citronella oil distilled in Formosa and isolated a sesquiterpene to which they assigned the name γ -cadinene. It had these properties:

b_{757}	266°	d_4^{30}	0.9089
b_4	117°–119°	n_D^{30}	1.5021

These authors assigned to their γ -cadinene this structural formula:

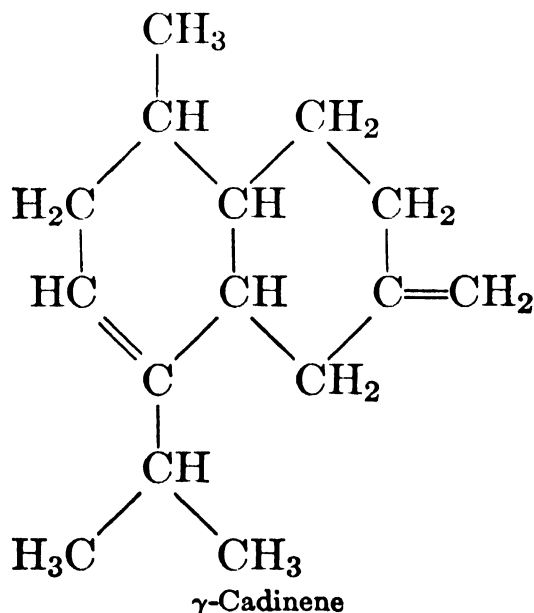

Plattner and Markus ²¹ identified an unusual cadinene from Java citronella oil; it yields a dihydrochloride m. 117.5°, and has these properties:

b ₁₂	108°–112°	n _D ²⁰	1.5098
d ₄ ²⁰	0.9231	M.R. calc.	66.14
		found	66.18

Use.—Cadinene as such is not used in our industries, but fractions of certain essential oils which contain cadinene—citronella, for example—occasionally serve for the scenting of soaps and technical preparations.

- ¹ *Helv. Chim. Acta* **7** (1924), 84.
- ² *J. Chem. Soc. Japan* **51** (1930), 518.
- ³ *J. Am. Chem. Soc.* **64** (1942), 417; **66** (1944), 1520.
- ⁴ *Ibid.* **64** (1942), 417.
- ⁵ *Liebigs Ann.* **238** (1887), 78.
- ⁶ *J. Chem. Soc.* **125** (1924), 1994.
- ⁷ *Chem. Ztg.* **38** (1914), 276.
- ⁸ *Liebigs Ann.* **238** (1887), 87.
- ⁹ *Pharm. Arch.* **2** (1899), 300.
- ¹⁰ "Die Ätherischen Öle," 3d Ed., Vol. I, 378.
- ¹¹ *J. prakt. Chem.* [2], **120** (1929), 121.
- ¹² *Compt. rend.* **135** (1902), 582, 1057.
- ¹³ *Liebigs Ann.* **238** (1887), 80.
- ¹⁴ *Compt. rend.* **208** (1939), 1411.
- ¹⁵ *J. Chem. Soc.* **125** (1924), 1992.
- ¹⁶ *Liebigs Ann.* **252** (1889), 150; **271** (1892), 297, 303.
- ¹⁷ *J. Am. Chem. Soc.* **64** (1942), 420.
- ¹⁸ *Parfums France* **7** (1929), 186.
- ¹⁹ *Helv. Chim. Acta* **7** (1923), 92.
- ²⁰ *J. Chem. Soc. Japan* **53** (1932), 636.
- ²¹ *Helv. Chim. Acta* **25** (1942), 1678.

Isocadinene

C₁₅H₂₄

Mol. Weight 204.34

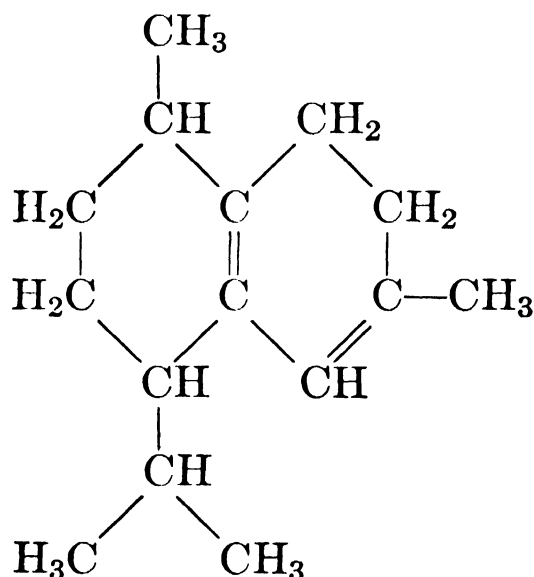

As the name implies, this sesquiterpene is an isomer of cadinene and can be obtained by treating cadinene with the Bertram-Walbaum mixture (gla-

cial acetic acid + sulfuric acid). Ruzicka and Capato ¹ prepared isocadinene synthetically from nerolidol and bisabolene. Troeger and Feldmann,² and Lepeschkin ³ isolated isocadinene from oil of cade.

The various products thus obtained had the following properties:

	b_{11-12}	d_{20}	n_D^{20}
Isocadinene	124°–126°	0.914	1.515
Cade oil sesquiterpene	124°–128°	0.918	1.515
Synthetic sesquiterpene	125°–126°	0.916	1.509

On dehydrogenation, isocadinene, like cadinene, yields cadalene, but unlike cadinene, isocadinene does not form a crystalline hydrochloride. Henderson and Robertson ⁴ suggested for isocadinene the structural formula pictured above, but gave no proof for their contention.

Use.—Isocadinene is not used in our industries.

¹ *Helv. Chim. Acta* **8** (1925), 259.

² *Arch. Pharm.* **236** (1898), 692.

³ *J. Russ. Phys. Chem. Soc.* **40** (1908), 126.

⁴ *J. Chem. Soc.* (1926), 2811.

Sesquiterpene from Camphor Oil

$C_{15}H_{24}$

Mol. Weight 204.34

Komatsu, Fujimoto and Tanaka ¹ isolated from camphor oil a sesquiterpene b_{12} 157°–160°, which on dehydrogenation with sulfur yielded cadalene. Komatsu, Fujimoto and Tanaka suggested for this sesquiterpene the following structural formula:

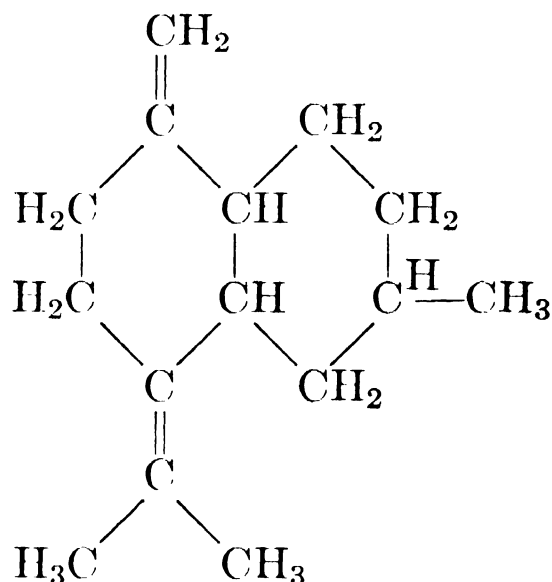

Use.—This sesquiterpene is not used as such in our industries but the fractions of camphor oil containing this hydrocarbon find wide application for the scenting of all kinds of technical preparations.

¹ *Mem. Coll. Sci. Kyoto Imp. Univ. A*, **14** (1931), 149. *Chem. Zentr.* II (1931), 3469.

Sumbulene

C₁₅H₂₄

Mol. Weight 204.34

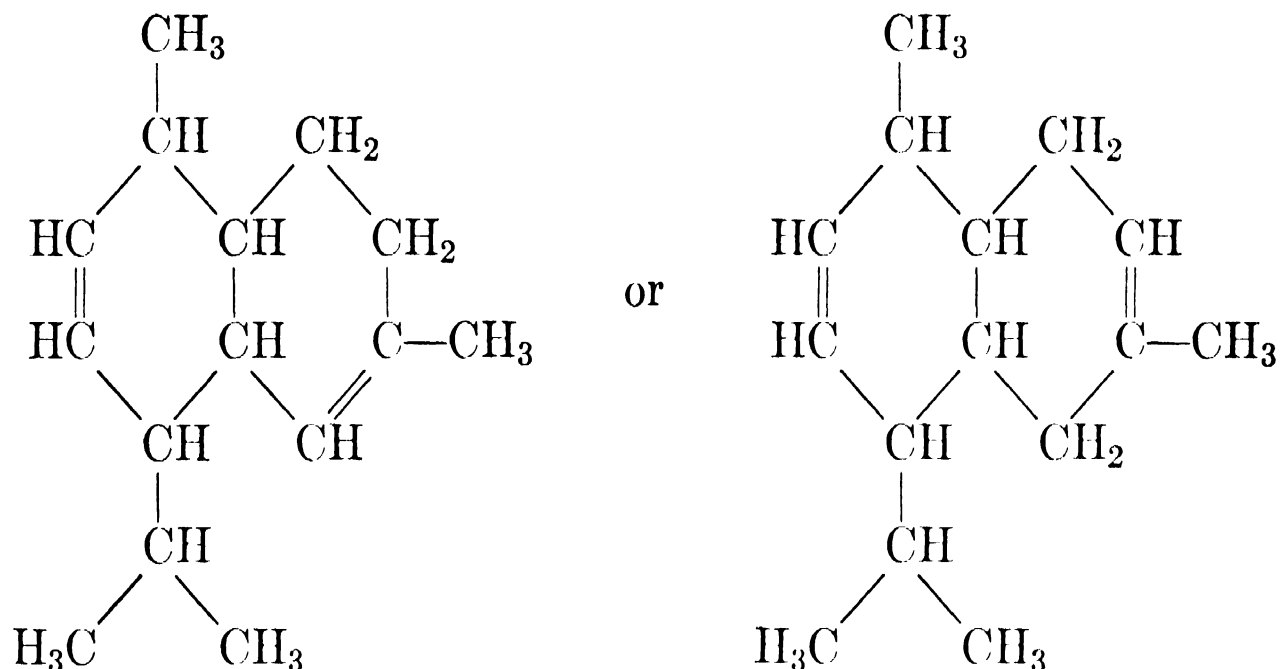

Occurrence.—Sumbulene was first reported in muskroot oil by Bauer.¹ According to Dyson,² it is the active odoriferous constituent of the volatile oil derived from the sumbul root (*Ferula sumbul* Hook., fam. *Umbelliferae*). Dyson suggested either one of the structural formulas pictured above.

Isolation.—By fractional distillation.

Identification.—On treatment with hydrochloric acid, sumbulene yields cadinene hydrochloride.

Properties.—Sumbulene is a clear, colorless liquid with an odor reminiscent of animal musk (?). Bauer³ reported the following properties of sumbulene:

b _{14.5}	120°–130°	[α] _D	+10° 21'
d ₂₀	0.8999	n _D	1.49618

Use.—Sumbulene is not used in our industries.

¹ Breslau Dissertation (1915). *Chem. Abstracts* **15** (1921), 2151.

² *Perfumery Essential Oil Record*, Special No. (1936), 6. Cf. *Ber. Schimmel & Co.* (1937), 83.

³ Breslau Dissertation (1915). *Chem. Abstracts* **15** (1921), 2151.

Sesquibeniene

 $C_{15}H_{24}$

Mol. Weight 204.34

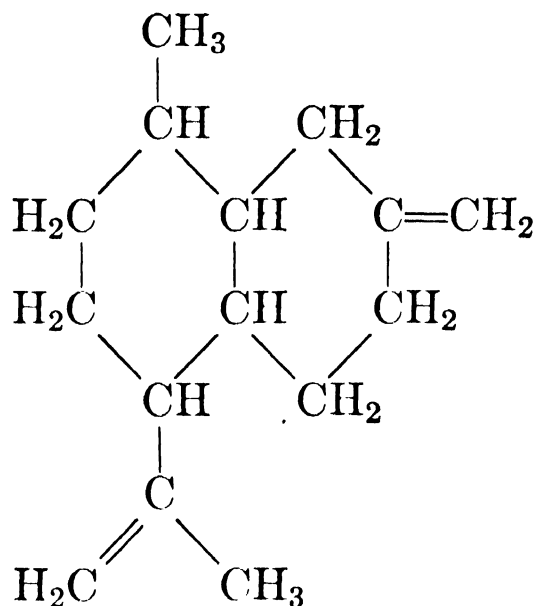

Occurrence.—In the volatile oil from the root of *Chamaecyparis formosensis* Matsum.

Isolation.—By repeated fractional distillation.

Identification.—By the physicochemical properties.

Properties.—Katsura ¹ reported these properties of sesquibeniene:

b_{10}	130°	$[\alpha]_D^{29}$	$-4^{\circ} 7'$
d_4^{29}	0.9560	n_D^{29}	1.5033

Almost ten years prior to this work of Katsura, Kafuku and Ichikawa ² had investigated the chemical composition of the oil derived from the wood of *Chamaecyparis formosensis* Matsum and found that it contains a new bicyclic sesquiterpene $C_{15}H_{24}$ —viz., *d*-sesquibeniene which seemed to be closely related to cadinene. The sesquibeniene isolated by Kafuku and Ichikawa had these properties:

b_{10}	$127^{\circ}-131^{\circ}$	α_D^{24}	$+35^{\circ} 42'$
d_4^{14}	0.9162	n_D^{24}	1.5088

Dihydrochloride m. $103^{\circ}-104^{\circ}$, dihydrobromide m. $112^{\circ}-114^{\circ}$, dihydroiodide m. $117^{\circ}-118^{\circ}$.

Use.—Sesquibeniene, as such, is not used in our industries.

¹ *J. Chem. Soc. Japan* **63** (1942), 1460, 1465, 1470, 1477. *Chem. Abstracts* **41** (1947), 3447.

² *Ibid.* **54** (1933), 1021.

Orthodonene

$C_{15}H_{24}$

Mol. Weight 204.34

This sesquiterpene belongs to the eudalene type.

Occurrence.—Fujita¹ found that the oil distilled from the herb *Orthodon lanceolatum* Kudo (fam. *Labiatae*) contains 2 per cent of a sesquiterpene with two double bonds, and he named this hydrocarbon orthodonene.

Isolation.—By fractional distillation.

Identification.—Orthodonene gives a nitrosite m. 152° – 154° .

Properties.—Fujita² reported these properties of orthodonene:

b_{770}	254°	α_D^{14}	$-13^{\circ} 17'$
d_4^{30}	0.9017	n_D^{30}	1.4947

Use.—Orthodonene is not used in our industries.

¹ *J. Chem. Soc. Japan* **54** (1933), 1181.

² *Ibid.*

The Caryophyllenes

$C_{15}H_{24}$

Mol. Weight 204.34

“Caryophyllene” is the term applied in the trade to a particular fraction of a number of essential oils, principally clove; this fraction most often yields evidence of being a mixture of $C_{15}H_{24}$ hydrocarbons, primarily bicyclic sesquiterpenes.

The literature discloses that to date at least three isomeric hydrocarbons have been derived from this commercial product, chiefly through their reactions, as they do not respond wholly to other separative means. These individual isolates possess particular properties and are universally referred to as α -, β - and γ -caryophyllenes.

Although the chemical relationship of these particular sesquiterpenes is not yet clear, researches in the last decade have enabled workers to advance structural formulas for some of these caryophyllenes.

These formulas incorporate a gem-dimethyl cyclobutane ring, the presence of which has been proved by oxidation of caryophyllene to caryophyllenic acid and to norcaryophyllenic acid, and through the synthesis of the latter by Rydon.¹ The nature of the second ring and the number of its ring members, as well as its substituents, are still in doubt. At the present time, evidence favors a formula with a fused 4- and 6-membered ring suggested by Ruzicka.² Ramage and Simonsen,³ after earlier explorations into the nature of the β - isomer, came to the conclusion that Ruzicka’s formula is probably

correct and that β - and γ -caryophyllene are stereoisomers. On the basis of Ruzicka's representation of β -caryophyllene, the two stereoisomers would have the following relationship:

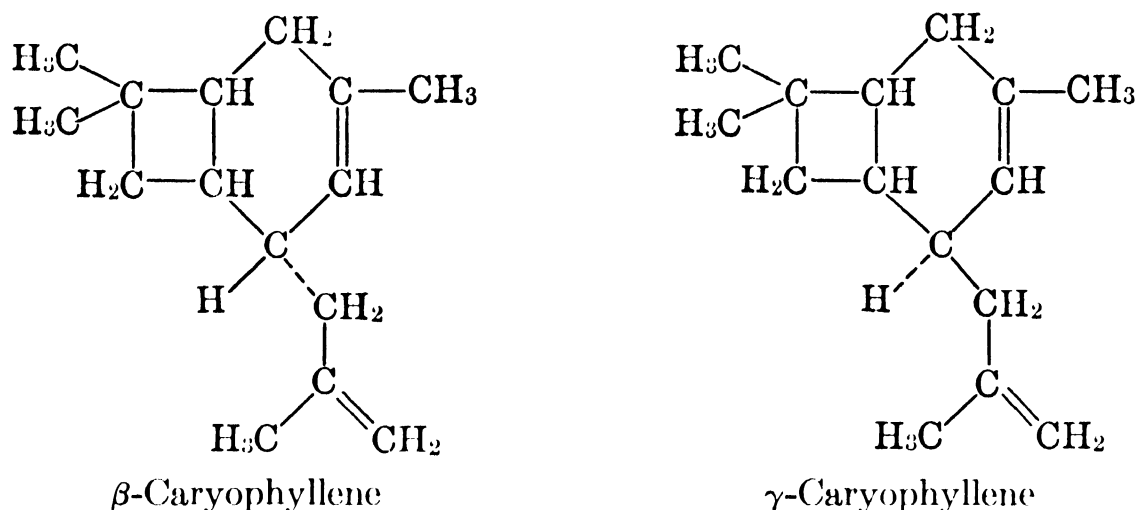

No commentary on the structure of the α - compound is justified at this writing.

Occurrence.— α -Caryophyllene occurs in clove bud and stem oil, and in hop oil; a content of 30 per cent has recently been reported by Kimura ⁴ in *Alpinia chinensis* Roscoe, in Egyptian hashish by Simonsen and Todd.⁵ Huzita ⁶ discovered this sesquiterpene in orthodon oils.

β -Caryophyllene occurs in oils of clove bud and clove stem, in African, Para and Maracaibo copaiba balsam, in Ceylon cinnamon and possibly cinnamon leaf, and in West Indian sandalwood oil. McElvain, Walters and Bright ⁷ reported 14 per cent in oil of catnip; Itikawa and Yamasita ⁸ identified the hydrocarbon in the volatile oil from *Vitex negundo* Linn.

A mixture of unidentified isomers of caryophyllene has been found in oils of lavender, thyme, pepper, pimenta and many others.*

Isolation.—The most convenient starting material for the isolation of this mixture of sesquiterpenes is clove bud and clove stem oil. However, the crude caryophyllene fraction obtained by mere fractional distillation from clove bud oil contains also some acetylenol which can be removed by saponification with alcoholic potassium hydroxide. The crude caryophyllene obtained by the fractionation of clove stem oil does not contain acetylenol.

For the isolation of crude caryophyllene, Semmler and Mayer ⁹ employed the following procedure:

“Shake clove oil with a slight excess of a 7 per cent soda solution in order to remove most of the eugenol, extract the aqueous solution with ether, and concentrate the ether extract on a steam bath until the ether is evaporated. Free the crude caryophyllene from remaining eugenol by repeated treatment with a 5 per cent soda solution, and distill the crude caryophyllene with steam.”

* According to Naves [*Helv. Chim. Acta* **31** (1948), 380], laryophyllene is not a natural, biological constituent of clove bud oil, but originates under the influence of boiling water in the course of steam distillation (cf. “Caryophyllene Oxide”).

When working with larger quantities, it will be preferable to isolate the caryophyllene by fractional distillation from clove bud or clove stem oil, and to remove any eugenol remaining in the caryophyllene fraction by treatment with sodium hydroxide solution.

A fraction boiling from 250°–260° will include the caryophyllenes from most sources.

Mere fractionation does not accomplish the resolution of these sesquiterpene distillates into chemically pure substances; however, the fractions thus obtained represent substantial yields of the isomers, as determined by the preparation of derivatives.

The product, identified as the β - isomer through its derivatives, ordinarily constitutes the principal portion of the caryophyllene fraction and may be obtained from the cut b_{9-10} 118°–120° with $\alpha_D \sim -8^\circ 0'$; the almost optically inactive fraction $b_3 \sim 100^\circ$ constitutes the α - isomer (boiling points determined in different laboratories). In both cases yield and properties of known characteristic derivatives will give an indication as to the percentage composition of these fractions. In this regard, see also next section on "Identification."

γ -Caryophyllene is best isolated, according to Deussen,¹⁰ by distillation of the reaction product after treatment of the blue β -nitrosite with hot alcohol.

Identification.—As the caryophyllenes are admittedly not homogeneous, diagnostic tests must necessarily take account of yield as well as properties of derivatives formed; these facts recommend the preparation of *several* compounds to serve as confirmatory evidence of composition.

The nitrogen derivatives most often used to characterize caryophyllenes, according to Deussen,^{11,12,13,14} Deussen, Loesche and Klemm,¹⁵ Deussen and Lewisohn,¹⁶ Ramage and Simonsen¹⁷ and Chapman,¹⁸ are summarized in the following tabulation, indicating melting points and optical rotations:

	α -	β -	γ -
Nitrosochloride	177° [α] _D $\pm 0^\circ 13$	159° [α] _D $-98^\circ 4' 16$	$\left\{ \begin{array}{l} \text{I } 122^\circ \\ \quad [\alpha]_D +14^\circ 43' 16,17 \\ \text{II } 147^\circ \\ \quad [\alpha]_D -33^\circ 41' 16 \end{array} \right.$
Nitrosite	116° ¹³	$\left\{ \begin{array}{l} \text{I (Blue) } 115^\circ \\ \quad [\alpha]_D +1666^\circ 0' 12,13 \\ \quad \text{(in petroleum ether)} \\ \text{II (White) } 134^\circ \\ \quad [\alpha]_D^{24} +112^\circ 0' 11 \\ \quad \text{(in 1.8\% benzene solution)} \end{array} \right.$	Does not form ¹⁶
Nitrol- benzylamine	136° ^{18*}	172° ^{14,16}	172° ^{14,16}
Nitrolpiperidine	153° ¹⁸
Nitrosate	163° ¹⁸
Nitrosobromide	144°–145° ¹²

Many of these compounds are photolytic and thermosensitive and thus care should be exercised in order to insure isolation of the expected derivative. This is especially true of the nitrosite (cf. Hoffmann,¹⁹ also Valenzuela and Daniels²⁰ and Deussen²¹).

Aside from the melting point, the optical rotation, too, may serve as a guide in identifying the sesquiterpene: the nitrosochlorides of the α -, β - and γ - compounds yield significantly different values for [α]_D, while the blue nitrosite of the β - isomer is remarkable in its high value.

* Prepared from the nitrosochloride.

Deussen et al.,²² using one of these nitrogenous derivatives, recommended the following sensitive test for the presence of β -caryophyllene:

When refluxed with ligroine, β -caryophyllene nitrosite forms dehydrocaryophyllene nitrosate, as well as another compound which can be purified by solution in acetone and precipitation with petroleum ether. The pure substance crystallizes in the form of white needles m. 159°. The same compound can be obtained if gaseous nitrous acid is conducted into an ethereal solution of caryophyllene. The solution will turn blue and, after saturation with gaseous nitrous acid, precipitate a voluminous whitish yellow substance, while the blue color disappears. After carefully redissolving in acetone or warm ethyl acetate, the compound can be obtained in the form of characteristic white silk-like needles m. 159°–160° (with decomposition).

A further reaction to identify these sesquiterpenes and to distinguish α - and β -isomers is the hydration of the caryophyllene fraction whereby α - and β -caryophyllene alcohols $C_{15}H_{26}O$ are obtained. This can be achieved by using the Bertram-Walbaum reagent:

Dissolve 25 g. of the hydrocarbon in a mixture of 1000 g. of glacial acetic acid, 25 g. of concentrated sulfuric acid and 40 g. of water, and warm the mixture for some time on a steam bath. Remove the more volatile products by steam distillation, and distill the pure alcohol.

Asahina and Tsukamoto²³ suggested hydrating caryophyllene by using Aschan's reagent (sulfuric acid monohydrate in ethereal solution) which reacts quicker and is easier to employ. From the mixture of β - and α -caryophyllene alcohol, the former may be separated by distillation in soda-alkaline solution, while the α - form may be isolated by acidifying the residue and distilling it. α -Caryophyllene alcohol has these properties:

m.	117°	$[\alpha]_D$	$\pm 0^\circ$
b_{10}	143°–152°	n_D^{17}	1.5010
d_4^{17}	0.9860	Phenylurethane	m. 180°

On dehydration, α -caryophyllene alcohol yields clovene but no isoclovene, and in this respect differs from β -caryophyllene alcohol.

The β -caryophyllene alcohol has been isolated by Wallach and co-workers,²⁴ and Asahina and Tsukamoto:²⁵

m.	94°–96° ²⁴
b.	287°–289° ²⁴
$[\alpha]_D$	$-5^\circ 48'$ ²⁵
Phenylurethane	m. 136°–137° ²⁴

The γ - product also melts at 95°–96°, according to Deussen.²⁶

Another derivative that in time may be most useful is the adduct, prepared in varying yields from the commercial caryophyllenes, with maleic anhydride:²⁷ $C_{19}H_{26}O_3$ -m. 98°, and the derived dicarboxylic acid $C_{19}H_{28}O_4$, m. 208°. However, the quantitative studies conducted by Ruzicka et al.,²⁸ as well as the investigations by Goodway and West,²⁹ and Naves and Perrottet,³⁰ indicate that in the addition compound the nature of the original sesquiterpene fraction remains still questionable; thus the exact correspondence to an α -, β - or γ - isomer is not clear.

A similar type of derivative has been prepared by Plattner and Werner³¹ from the dimethyl ester of acetylene dicarboxylic acid. This ester, upon hydrolysis, yields an acid derivative m. 122°–123° and a prepared *trans*-dianilide m. 228°. These authors also secured the adduct of caryophyllene with azodiformic ethyl ester C₂₁H₃₄N₂O₄, m. 139°.

A further compound frequently used to characterize the β- isomer is the dihydrochloride, which is obtained, according to Robertson, Kerr and Henderson,³² by treating an ethereal solution of the caryophyllene with dry hydrogen chloride gas at 0°, whereby the dextrorotatory dihydrohalide m. 69°, [α]_D¹⁵ +67° 12' (in alcohol), is formed in nearly quantitative yields. That the γ- product gives a dihalogen derivative of similar melting point was earlier confirmed by Deussen.³³ α-Caryophyllene, on the other hand, does not yield a crystalline dihydrochloride, differing thereby from the other isomers.

Properties.—As indicated above, all evidence points toward the chemical impurity of the “caryophyllenes.” The following properties describe isolates obtained by Walbaum and Hüthig,³⁴ Schimmel & Co.,³⁵ Deussen,³⁶ Ramage and Simonsen,³⁷ Deussen,³⁸ Chapman,³⁹ Robertson, Kerr and Henderson,⁴⁰ Gibson, Robertson and Sword,⁴¹ Ruzicka, Huber, Plattner, Deshpande and Studer,⁴² Naves and Perrottet,⁴³ Goodway and West,⁴⁴ Rydon,⁴⁵ Ruzicka and Wind⁴⁶ and Seidel, Müller and Schinz:⁴⁷

	α-		β-		γ-	
b.	b ₁₆ b ₃	132°–134° ³⁸ 99°–100° ³⁹	b. b _{11–12} b ₁₀ b _{9.7} b ₄ b _{0.03}	260°–261° ^{34,35} 119°–121° ^{45,46} 118°–121° ⁴² 118°–119° ⁴⁰ 103°–103.5° ⁴³ 58°–60° ⁴⁷	b ₂₄ b _{14.5} b ₁₄	130°–131° ³⁷ 125°–125.5° ³⁸ 124.5°–125° ³⁶
d	d ₂₀ ²⁰ d ₂₀	0.8923 ³⁹ 0.90346 ³⁸	d ₄ ²⁰ d ₄ ¹⁷ d ₁₅ ¹⁵	0.9075 ⁴³ 0.9052 ⁴⁰ 0.9047 ^{34,35}	d ₂₅ ²⁵ d ₁₉	0.8923 ³⁷ 0.89951 ³⁸
α _D	α _D ²⁰ [α] _D	–4° 40' ³⁸ +1° 42' ³⁹	α _D α _D α _D α _D ¹⁶ α _D	–8° 54' ⁴⁶ –7° 20' to –8° 48' ^{34,35,42} –8° 42' ⁴⁴ –8° 31' ⁴⁵ –8° 10' ⁴³	α _D ¹⁹ [α] ₅₄₆₁	–26° 10' ³⁸ –29° 42' ³⁷
n _D	n _D ²⁰	1.5001 ³⁹	n ₂₀ n _{16–17} n ₁₅	1.4995 to 1.5005 ^{43,44} 1.5009 ^{40,45,46} 1.5030 ⁴¹	n _D ²⁵ n _D ¹⁹	1.4942 ³⁷ 1.49665 ³⁸

These data represent constants from several sources. Walbaum and Hüthig³⁴ isolated their product from Ceylon cinnamon oil; Schimmel & Co.,³⁵ and Naves and Perrottet⁴³ distilled their fractions from clove oil, whereas the α - products came from both hop and clove oil. All γ -caryophyllenes were derived through the β -caryophyllene nitrosite.

A most valuable index as to what the trade is producing in several quarters may be had by reference to a recent publication by Ruzicka et al.⁴⁸ who report the following constants determined simultaneously on lots of current industrial distillations:

Constant	Schimmel 1933	Givaudan	Clove Ext.	Firmenich	Schimmel
b_{10}	119°-120°	118°-120°	118°-121°	120°-122°	119°-122°
d_4^{20}	0.9054	0.9003	0.9025	0.9030	0.9049
α_D	-8° 22'	-7° 4'	-8° 19'	-7° 46'	-8° 54'
n_D^{20}	...	1.4999	1.5001	1.5001	1.5000
Calc. M.R. 66.14	...	66.74	66.60	66.56	66.41

It has already been mentioned that the caryophyllenes can be hydrated to alcohols possessing characteristic properties.

An exhaustive investigation on hydrogenation has been carried out by Naves and Perrottet.⁴⁹

Lastly, where diagnosis demands support from oxidative products of degradation, the worker should be guided by the findings of Rydon,⁵⁰ Ruzicka et al.,⁵¹ and Evans et al.⁵² These researches have not only supplied the key to the structure of the β - and γ - isomers but also demonstrated certain proved oxidation products (caryophyllenic and norcaryophyllenic acids) as characteristic of the natural caryophyllenes. A flow sheet of the possibilities in this scheme of derivatives is illustrated here. Ozone and nitric acid are ordinarily used to obtain these oxidation products:

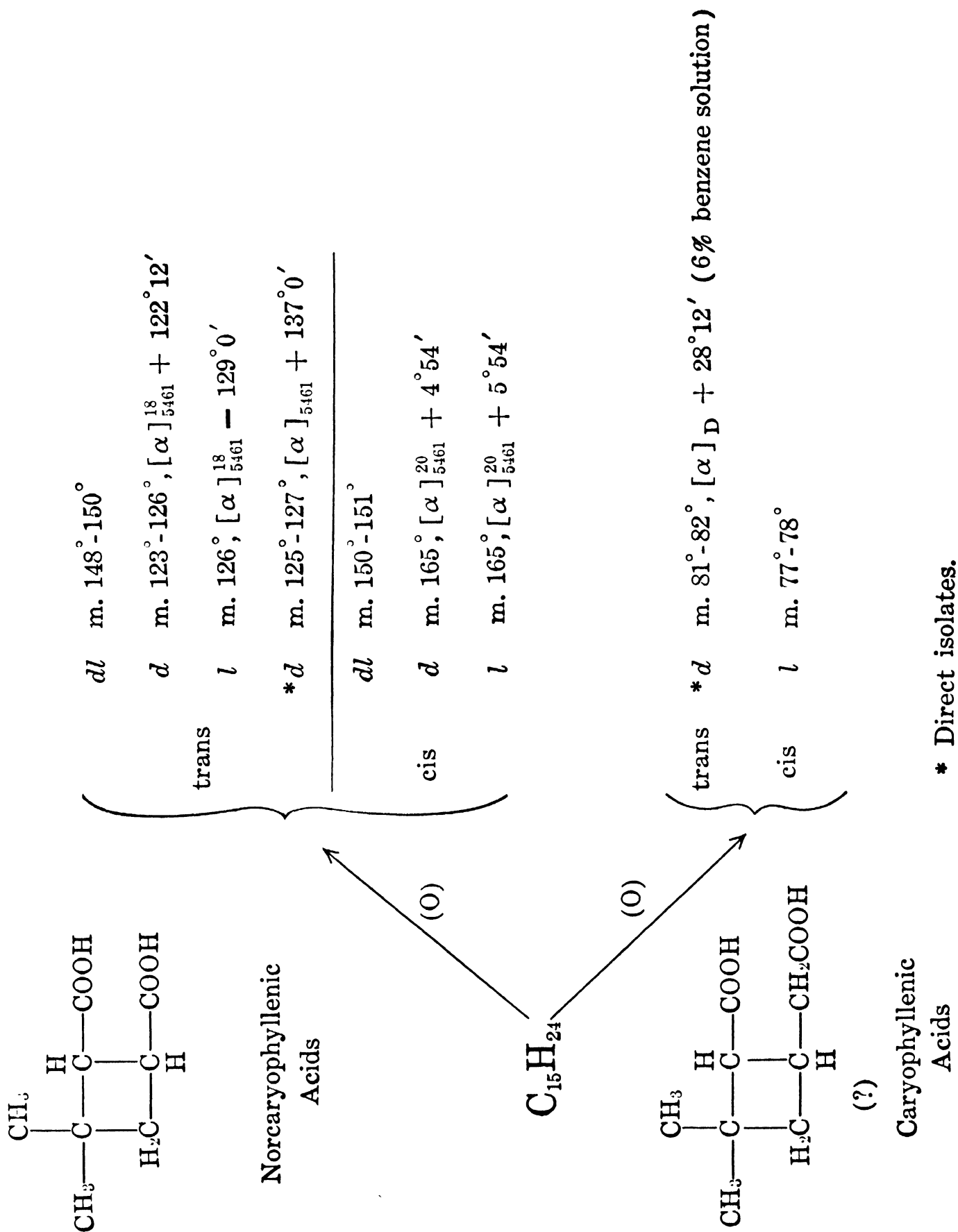

Use.—Caryophyllene fractions are quite widely used for the scenting of cosmetics and soaps, and of many technical preparations.

¹ *J. Chem. Soc.* (1936), 593; (1937), 1340.

² *J. Soc. Chem. Ind.* **54** (1935), 509. Cf. Ruzicka and Zimmermann, *Helv. Chim. Acta* **18** (1935), 219.

³ *J. Chem. Soc.* (1938), 1208. Cf. *Ibid.* (1937), 73; (1936), 741; (1935), 532, 1581; (1934), 1806. Naves and Perrottet (*Helv. Chim. Acta* **24** (1941), 789) consider caryophyllene principally a homogeneous hydrocarbon. In a recent publication on caryophyllene oxide, Treibs (*Chem. Ber.* **80**, No. 1 (1947), 56) presented some chemical evidence against Ruzicka's caryophyllene formula.

- ⁴ *J. Pharm. Soc. Japan* **60** (1940), 145; *Abstracts* (in German) **51**. *Chem. Zentr.* II (1940), 2504.
- ⁵ *J. Chem. Soc.* (1942), 188.
- ⁶ *J. Chem. Soc. Japan* **60** (1939), 1081; **61** (1940), 137. *Chem. Abstracts* **36** (1942), 6312 6752.
- ⁷ *J. Am. Chem. Soc.* **64** (1942), 1828.
- ⁸ *J. Chem. Soc. Japan* **61** (1940), 787. *Chem. Abstracts* **36** (1942), 7241.
- ⁹ *Ber.* **43** (1910), 3452. See also Schreiner and Kremers, *Pharm. Arch.* **2** (1899), 280.
- ¹⁰ *J. prakt. Chem.* **145** (1936), 31. *Liebigs Ann.* **359** (1908), 251.
- ¹¹ *J. prakt. Chem.* [2], **114** (1926), 109.
- ¹² *Ibid.* **145** (1936), 31.
- ¹³ *Ibid.* **120** (1929), 140; [2], **83** (1911), 484.
- ¹⁴ *Liebigs Ann.* **388** (1912), 136.
- ¹⁵ *Ibid.* **369** (1909), 48.
- ¹⁶ *Ibid.* **359** (1908), 245; **356** (1907), 8.
- ¹⁷ *J. Chem. Soc.* (1938), 1208.
- ¹⁸ *Ibid.* (1928), 785.
- ¹⁹ *J. Am. Chem. Soc.* **56** (1934), 1894.
- ²⁰ *Philippine J. Sci.* **34** (1927), 187.
- ²¹ *Liebigs Ann.* **388** (1912), 155.
- ²² *J. prakt. Chem.* II, **90** (1914), 324. *Liebigs Ann.* **388** (1912), 138.
- ²³ *J. Pharm. Soc. Japan* No. 484 (1922), 463; see also **49** (1929), 186, 1202. Cf. Simonsen, "The Terpenes," Vol. II (1932), 527.
- ²⁴ *Liebigs Ann.* **271** (1892), 288; **279** (1894), 393.
- ²⁵ *J. Pharm. Soc. Japan* No. 484 (1922), 463. *Chem. Abstracts* **16** (1922), 3312.
- ²⁶ *J. prakt. Chem.* **145** (1936), 31.
- ²⁷ Ruzicka and Zimmerman, *Helv. Chim. Acta* **18** (1935), 219.
- ²⁸ *Helv. Chim. Acta* **24** (1941), 1219.
- ²⁹ *J. Chem. Soc.* (1939), 1853.
- ³⁰ *Helv. Chim. Acta* **24** (1941), 789.
- ³¹ *Ibid.* **27** (1944), 1010. *Chem. Abstracts* **39** (1945), 1634.
- ³² *J. Chem. Soc.* **127** (1925), 1945.
- ³³ *Z. angew. Chem.* **36** (1923), 348. *Liebigs Ann.* **388** (1912), 155.
- ³⁴ *J. prakt. Chem.* II, **66** (1902), 54.
- ³⁵ *Ber. Schimmel & Co.*, Oct. (1910), 173.
- ³⁶ *J. prakt. Chem.* II, **90** (1914), 324.
- ³⁷ *J. Chem. Soc.* (1938), 1208.
- ³⁸ *Liebigs Ann.* **359** (1908), 246, 252.
- ³⁹ *J. Chem. Soc.* (1928), 785.
- ⁴⁰ *Ibid.* **127** (1925), 1945.
- ⁴¹ *Ibid.* **129** (1926), 165.
- ⁴² *Helv. Chim. Acta* **22** (1939), 722.
- ⁴³ *Ibid.* **24** (1941), 796.
- ⁴⁴ *J. Chem. Soc.* (1939), 1853.
- ⁴⁵ *Ibid.* (1939), 537.
- ⁴⁶ *Helv. Chim. Acta* **14** (1931), 427.
- ⁴⁷ *Ibid.* **27** (1944), 738.
- ⁴⁸ *Helv. Chim. Acta* **24** (1941), 1219.
- ⁴⁹ *Ibid.* **24** (1941), 789.
- ⁵⁰ *J. Soc. Chem. Ind.* **54** (1935), 315. *J. Chem. Soc.* (1936), 593; (1937), 1340.
- ⁵¹ *Helv. Chim. Acta* **14** (1931), 423; **18** (1935), 219; **19** (1936), 343; **26** (1943), 966.
- ⁵² *J. Chem. Soc.* (1934), 1806; (1935), 532, 1581; (1936), 741. Ramage and Simonsen, *ibid.* (1937), 73.

SUGGESTED ADDITIONAL LITERATURE

W. R. Littlejohn, "The Caryophyllenes," *Perfumery Essential Oil Record* **39** (1948), 190.

Humulene

C₁₅H₂₄

Mol. Weight 204.34

Although our present knowledge does not permit advancing a structure for this compound, it is apparent that humulene and α -caryophyllene are very closely related. The exact nature of this relationship still awaits chemical clarification. Among some investigators these products are regarded as isomeric forms of the same molecule (cf. Deussen,¹ and Evans, Ramage and Simonsen²), a possibility that seems not unlikely.

Occurrence.—Chapman³ first isolated humulene from oil of hops, later from clove oil but in much smaller proportion.

Isolation.—By fractional distillation of oil of hops: b. 256°–261°, b₆₀ 168°–173°, and rectification over sodium.

Identification.—Chapman⁴ recorded the following information relative to derivatives prepared from humulene:

Dihydrochloride	Crystalline form not isolated
Nitrosochloride	m. 176°
Nitrolpiperidine	m. 153°
Nitrolbenzylamine	m. 136°
Nitrosate	m. 163°
Nitrosite	m. 114°

Properties.—Chapman⁵ found these properties for purified humulene:

	(1895)		(1928)
b.	263°–266°	b ₃	99°–100°
d ₁₅ ¹⁵	0.9001		
d ₂₀ ²⁰	0.8977	d ₂₀ ²⁰	0.8923
[α] _D ²⁰	–0° 30' to +1° 30'	[α] _D	+1° 42'
n _D ¹⁹	1.5021	n _D ²⁰	1.5001

Use.—Humulene is not used in our industries.

¹ *J. prakt. Chem.* [2], **83** (1911), 483; [2], **120** (1929), 133.

² *J. Chem. Soc.* (1934), 1806.

³ *Ibid.* **67** (1895), 54, 780; (1928), 785; (1929), 359.

⁴ *Ibid.* (1928), 785.

⁵ *Ibid.* **67** (1895), 54, 780; (1928), 785; (1929), 359.

SUGGESTED ADDITIONAL LITERATURE

Stotherd Mitchell, "Asymmetric Photochemical Decomposition of Humulene Nitrosite by Circularly Polarized Light," *J. Chem. Soc.* (1930), 1829–34.

Selinene

 $C_{15}H_{24}$

Mol. Weight 204.34

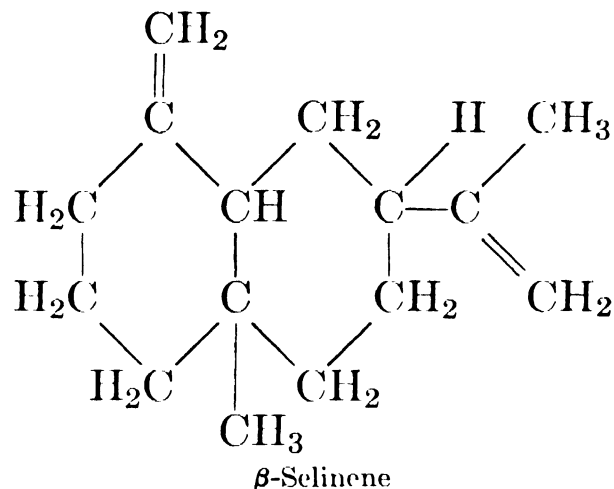
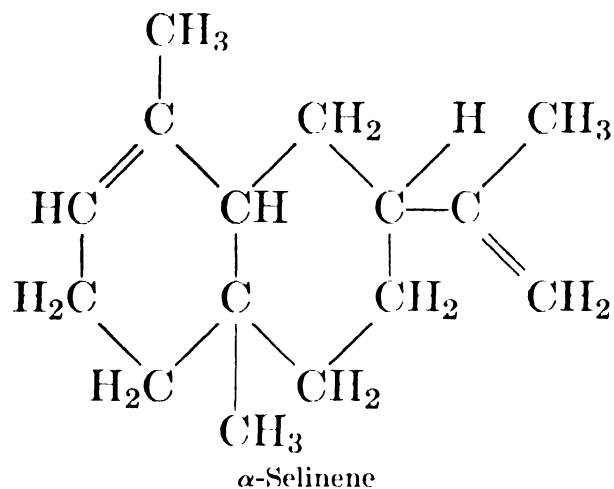

This bicyclic sesquiterpene containing two ethylenic linkages was first observed in oil of celery seed by Ciamician and Silber¹ and later identified by Schimmel & Co.² Semmler and Risse³ expressed the opinion that the naturally occurring sesquiterpene is a mixture of α - and β -selinene in which the β -form largely predominates. The same authors found that the natural sesquiterpene and that regenerated from its hydrochloride differ in regard to their physical properties; they named the former β -selinene and the latter α -selinene. Ruzicka and collaborators⁴ made the important observation that β -selinene on dehydrogenation yields eudalene and postulated the structural formulas shown above for the two isomers.

Occurrence.—The oil distilled from the seed of celery (*Apium graveolens*) contains about 20 per cent of selinene.

Isolation.—Celery seed oil is first freed from phenolic constituents by shaking it with an aqueous 5% sodium hydroxide solution; the oil is then fractionated, the fraction b. 265°–273° consisting mainly of selinene. The sesquiterpene may be purified by the preparation of its dihydrochloride and by regenerating selinene from the dihydrochloride.

Identification.—Selinene can be characterized by its dihydrochloride m. 72°–74°, $[\alpha]_D +18^\circ 0'$ (in chloroform), which is formed from both the α - and the β -isomer by conducting a current of gaseous hydrochloric acid (diluted with 3 parts of air) through an ethereal solution of the sesquiterpene.

Ruzicka, Wind and Koolhaas⁵ reported that the freshly prepared dihydrochloride has a melting point of 52°, $[\alpha]_D -70^\circ 0'$ (in chloroform), but that on keeping for some years it changes into a higher melting dihydrochloride m. 72°–74°. When heated with milk of lime at 95°, the dihydrochloride is converted into selinenol or α -eudesmol m. 78°–79°, $[\alpha]_D +38^\circ 0'$ (in chloroform). (See "Eudesmol" or "Selenol.")

Properties.—The following properties have been reported for selinene:

α -Selinene (regenerated from the dihydrochloride):

b_{11}	128°–132°	α_D	+61° 36'
d_{20}	0.9190	n_D^{20}	1.50920

Semmler and Risse ⁶ obtained this product by treating its dihydrochloride with potassium hydroxide in methyl alcoholic solution. When using sodium ethylate for the regeneration from the dihydrochloride, Schimmel & Co.⁷ obtained α -selinene having these properties:

b.	268°–272°	α_D	+49° 30'
d_{15}^{15}	0.9232	n_D^{20}	1.50483
d_{20}	0.9196		

β -Selinene (natural product), according to Semmler and Risse:

b_{17}	136°–139°	α_D	+31° 36'
d_{20}	0.9107	n_D^{20}	1.50311

Selinene is structurally related to dipentene: like dipentene, α -selinene can be isomerized readily by treatment with sulfuric acid in alcoholic solution, whereby, according to Ruzicka and Stoll,⁸ a hydrocarbon, probably either δ - or ϵ -selinene, b_{12} 130°, d_4^{14} 0.9234, α_D +194° 18', n_D^{14} 1.5167 is obtained. This hydrocarbon no longer forms a crystalline dihydrochloride.

Use.—Selinene, as such, is not used in our industries.

¹ *Ber.* **30** (1897), 492, 496, 501.

² *Ber. Schimmel & Co.*, April (1910), 96.

³ *Ber.* **45** (1912), 3301, 3725; **46** (1913), 599.

⁴ *Helv. Chim. Acta* **5** (1922), 363, 926; **6** (1923), 846.

⁵ *Ibid.* **14** (1931), 1147.

⁶ *Ber.* **45** (1912), 3301, 3725; **46** (1913), 599.

⁷ *Ber. Schimmel & Co.*, April (1910), 96.

⁸ *Helv. Chim. Acta* **6** (1923), 850.

Eudesmene

$C_{15}H_{24}$

Mol. Weight 204.34

Baker and Smith,¹ and Penfold² isolated from the oils of several *Eucalyptus* and *Leptospermum* species a bicyclic sesquiterpene $C_{15}H_{24}$ which was named eudesmene. Semmler and collaborators³ prepared eudesmene by dehydration of eudesmol, a bicyclic sesquiterpene alcohol frequently occurring in eucalyptus oil. Ruzicka, Meyer and Mingazzini⁴ obtained eudesmene by boiling eudesmol with concentrated formic acid. However, according to Ruzicka, Wind and Koolhaas,⁵ the naturally occurring sesquiterpene to which the name eudesmene had been assigned is not identical with the synthetic eudesmene but rather with one of the selinenes. (See also "Selinene.")

Occurrence.—In several *Eucalyptus* and *Leptospermum* oils (?).

Isolation.—By fractional distillation.

Properties.—The eudesmene prepared by Semmler and collaborators ⁶ and regenerated from the dihydrochloride m. 79°–80° had these properties:

b ₇	122°–124°	[α] _D	+54° 6'
d ₂₀	0.9196	n _D	1.50874

Ruzicka, Meyer and Mingazzini ⁷ reported for their synthetic eudesmene:

b ₁₅	132°–136°	α _D	+52° 36'
d ₄ ²⁰	0.9175	n _D ¹⁹	1.5134

Ruzicka, Wind and Koolhaas ⁸ reported for eudesmene dihydrochloride a melting point of 74°–75°.

Use.—Eudesmene is not used in our industries.

¹ *J. Proc. Roy. Soc. N. S. Wales* **45** (1911), 267.

² *Ibid.* **54** (1920), 197; **55** (1921), 170; **56** (1922), 82, 162. *Perfumery Essential Oil Record* **13** (1922), 82.

³ *Ber.* **46** (1913), 2029, 2303.

⁴ *Helv. Chim. Acta* **5** (1922), 362.

⁵ *Ibid.* **14** (1931), 1132, 1139.

⁶ *Ber.* **46** (1913), 2029, 2303.

⁷ *Helv. Chim. Acta* **5** (1922), 362.

⁸ *Ibid.* **14** (1931), 1132, 1139.

SUGGESTED ADDITIONAL LITERATURE

Briggs and Short, "Sesquiterpene Alcohol of the Oil of *Eucalyptus nova-anglica*," *J. Soc. Chem. Ind.* **47** (1928), 323T.

L. Ruzicka, Pl. A. Plattner and A. Fürst, "Degradation of Dihydroeudesmol with Chromic Acid," *Helv. Chim. Acta* **25** (1942), 1364.

Aromadendrene

C₁₅H₂₄

Mol. Weight 204.34

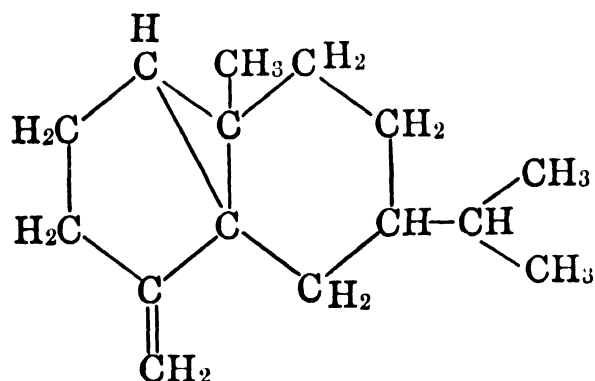

This structural formula of aromadendrene, a sesquiterpene containing one ethylenic linkage, was suggested by Radcliffe and Short,¹ and later was confirmed by Naves and Perrottet.²

Occurrence.—According to Smith,³ aromadendrene is the principal sesquiterpene occurring in several eucalyptus oils—for example, *E. globulus*, *E. rari-*

flora, *E. nova-anglica*, and in the oils derived from various *Leptospermum* species. In the majority of eucalyptus oils, aromadendrene occurs associated with eudesmol.

Isolation.—By fractional distillation.

Identification.—The presence of aromadendrene is indicated by the following color reaction:

Dissolve two drops of aromadendrene in 2 to 3 cc. of glacial acetic acid and conduct bromine vapors into the test tube. On shaking, the solution will assume a crimson color which soon changes to violet and indigo blue if aromadendrene is present. As this color reaction is likewise displayed by guaiane and eudesmene, its value remains questionable.

According to Radcliffe and Short,⁴ aromadendrene, on oxidation with varying amounts of potassium permanganate, yields aromadendrone $C_{14}H_{22}O$, m. 84.5° – 85° (recrystallized from ice cold methanol), aromadendrene glycol $C_{15}H_{26}O_2$, m. 118° , and traces of an acid m. 175° – 175.5° (decomp.). The glycol can be further oxidized to aromadendrone, a saturated ketone which reacts with benzaldehyde, yielding a mono-benzylidene derivative m. 66° – 66.5° ; *p*-nitrophenylhydrazone m. 131° ; semicarbazones, α - m. 195° – 196° (decomp.), β - m. 201.5° – 202.5° (decomp.).

Properties.—Briggs and Short,⁵ and Naves and Perrottet⁶ reported these properties for aromadendrene:

b_{10}	121° ⁵	α_D	$+4^{\circ} 48'$ ⁶
b_6	114° ⁶	$[\alpha]_{577}^{20}$	$-6^{\circ} 6'$ ⁵
d_4^{20}	0.9116 ⁵	n_D^{20}	1.4978 ⁵
d_4^{20}	0.9166 ⁶	n_D^{20}	1.4982 ⁶

These latter authors likewise reported other properties such as the parachor and spectral data.

Radcliffe and Short⁷ recorded the following properties of sesquiterpene fractions from eucalyptus oils containing aromadendrene:

Source	b_{10}	d_4^{20}	α_{5770}	n_D^{20}
<i>E. rariflora</i>	122° – 127°	0.9122 – 0.9197	$+1^{\circ} 4'$ to $+15^{\circ} 41'$	1.4991 – 1.5024
<i>E. globulus</i>	120° – 125°	0.9159	$+0^{\circ} 48'$ to $+2^{\circ} 4'$	1.4990 – 1.5004

Dehydrogenation of aromadendrene yields S-guaiazulene, picrate m. 122° .

Use.—Aromadendrene, as such, is not used in our industries.

¹ *J. Chem. Soc.* (1938), 1200.

² *Helv. Chim. Acta* **23** (1940), 912. *Chem. Abstracts* **35** (1941), 109.

³ *J. Proc. Roy. Soc. N. S. Wales* **35** (1901), 124. Baker and Smith, "A Research on the Eucalypts," 2nd Ed. (1920), 416. See also Briggs and Short, *J. Chem. Soc.* (1928), 2524.

⁴ *J. Chem. Soc.* (1938), 1200.

⁵ *Ibid.* (1928), 2527.

⁶ *Helv. Chim. Acta* **23** (1940), 914.

⁷ *J. Chem. Soc.* (1938), 1200.

Calamene

 $C_{15}H_{24}$

Mol. Weight 204.34

The constitution of this hydrocarbon has not been determined. It was named calamene by Semmler and Spornitz¹ who isolated it from calamus root oil. Ruzicka and collaborators² found that on dehydrogenation with sulfur, calamene is reduced to cadalene. From this and the fact that calamene on catalytic hydrogenation yields tetrahydrocalamene $C_{15}H_{28}$, it may be assumed that calamene is a bicyclic sesquiterpene of the cadinene group, containing two ethylenic linkages. However, it would appear from the recent publications of Böhme³ that this hydrocarbon needs considerably more study in order to elaborate its structure, as this author has reported an empirical formula of $C_{15}H_{22}$ and a boiling range of 137° – 139° at 12 mm. for a calamene-like sesquiterpene.

Occurrence.—Calamene occurs in the oil distilled from the rhizomes of *Acorus calamus* L.

Isolation.—By fractional distillation *in vacuo* of calamus root oil; the fraction b_{12} 130° – 135° contains the sesquiterpene.

Identification.—Calamene does not yield any crystalline derivatives. It cannot be hydrated.

Properties.—Distilling the sesquiterpene over metallic sodium, Semmler and Spornitz⁴ obtained calamene with the following properties; Ruzicka⁵ also reported on calamene:

b_{14}	127° – 130° ⁵	α_D	$+5^{\circ} 0'$ ⁴
$b_{10.5}$	123° – 126° ⁴	n_D^{20}	1.50572 ⁴
d_{19}^{20}	0.9224 ⁴	n_D^{19}	1.5023 ⁵
d_{15}^{15}	0.9231 ⁵		

Use.—Calamene is not used in our industries.

¹ *Ber.* **46** (1913), 3700.

² *Helv. Chim. Acta* **5** (1922), 348, 358.

³ *Arch. Pharm.* **278** (1940), 1.

⁴ *Ber.* **46** (1913), 3700.

⁵ *Helv. Chim. Acta* **5** (1922), 348, 358.

(d) TRICYCLIC SESQUITERPENES.

The Santalenes

 $C_{15}H_{24}$

Mol. Weight 204.34

Before discussing these tricyclic constituents of East Indian sandalwood oil, it seems advisable to describe briefly the teresantallic acid to which these substances can be degraded.

Teresantalic Acid

$C_{10}H_{14}O_2$

Mol. Weight 166.21

This tricyclic acid occurs free and as ester in East Indian sandalwood oil. The following structural formulas were assigned to it:

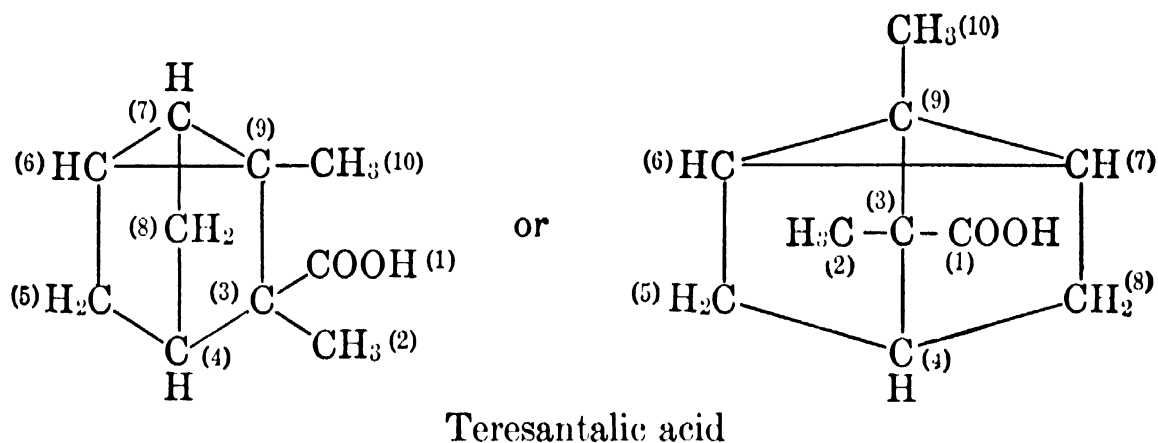

Ruzicka and Stoll,¹ however, pointed out that both formulas are structurally identical, differing merely in regard to their spatial arrangement.

According to Asahina, Ishidate and Momose,² teresantalic acid melts at 158° , b_{20} 155° – 156° , $[\alpha]_D^{18}$ $-74^\circ 12'$ (in benzene). It is extremely resistant to oxidizing agents, but readily attacked by hydrogen chloride with resulting ring fission and formation of a hydrochloride m. 199° . On reduction, this hydrochloride, according to Semmler and Bartelt,³ yields dihydroteresantalic acid m. 226° .

¹ *Helv. Chim. Acta* **5** (1922), 928.

² *Ber.* **68** (1935), 87. Cf. Rupe and Tomi, *Ber.* **49** (1916), 2563; and Ruzicka and Thomann, *Helv. Chim. Acta* **18** (1935), 355.

³ *Ber.* **40** (1907), 3102.

α - and β -Santalene

The two sesquiterpenes occurring in East Indian sandalwood oil, viz., α - and β -santalene, have been the subject of many investigations. The structural formula of α -santalene, a tricyclic sesquiterpene, has been established, whereas that of β -santalene, a bicyclic sesquiterpene, has only been suggested by Ruzicka and Thomann¹ who point out that these products are related to one another as tricyclene and camphene. The two hydrocarbons can be separated only by prolonged fractional distillation; therefore, it is doubtful whether either one has been obtained in pure form. Moreover, other "santalenes" have been obtained synthetically but little is known about their constitution.

¹ *Helv. Chim. Acta* **18** (1935), 355.

*α-Santalene*C₁₅H₂₄

Mol. Weight 204.34

α-Santalene is a derivative of teresantallic acid and, in another sense, of eudalene (see also "*α*-Santalol").

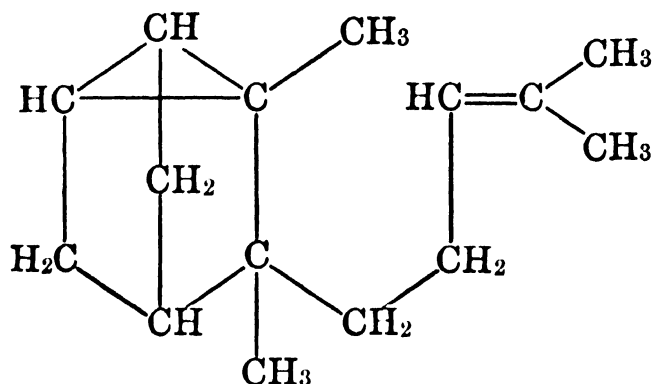

Occurrence.—In East Indian sandalwood oil.

Isolation.—By repeated fractional distillation of East Indian sandalwood oil.

Identification.—*α*-Santalene can be characterized by the preparation of its nitrosochloride. It is advisable to use the method of Ehestädt,¹ Wallach's method not being well suited for this purpose.

A concentrated sodium nitrite solution is added very slowly (drop by drop) to one and a half of the theoretically necessary quantity of 32% hydrochloric acid, and the gases thus created are conducted into an ice-cold ethereal solution (1:1) of *α*-santalene. The nitrosochloride will have a melting point of 112°–117°.

Or, a solution of nitrosylchloride in petroleum ether is added, at low temperature, to a solution of *α*-santalene in petroleum ether. According to Guerbet,² the melting point of the nitrosochloride, in this case, is 122°. The nitrosochloride yields a nitropiperidine m. 108°–109°.

Properties.—The following properties have been reported for *α*-santalene by Schimmel & Co.³ and Semmler:⁴

b ₇₅₃	252° ³	d ₂₀	0.8984 ⁴
b ₉	118°–120° ⁴	d ₁₅ ¹⁵	0.9132 ³
b ₇	118° ³	α _D	–3° 34' ³
		n _D ¹⁵	1.49205 ³

Values reported for α_D vary from –3° to –15°, indicating that the isolate is a mixture of the *α*- and *β*- form, a fact confirmed by Ruzicka and Thomann.⁵

For a 93 per cent pure *α*-santalene, Guha and Bhattacharyya⁶ reported these properties:

b ₇	117°	d ₄ ²⁰	0.9102
[α] ₅₇₈₀	+2° 4' (calc. for pure compound +6° 29')	n _D ²⁰	1.4900

On treatment with hydrogen chloride, *α*-santalene gives a liquid dihydrochloride b_{0.55} 140°–142°, d₂₀ 1.076, n_D 1.4976, whereby fission of the cyclopropane ring takes place (Semmler⁷).

On hydration, α -santalene yields a tertiary alcohol $C_{15}H_{26}O$, b_{5-6} 154° – 157° , d_{15}^{15} 0.9787, n_D^{20} 1.51725, which on dehydration with formic acid gives a sesquiterpene not identical with α -santalene.

Use.— α -Santalene, as such, is not used in our industries.

¹ *Ber. Schimmel & Co.*, Oct. (1910), 107; April (1910), 165.

² *Compt. rend.* **130** (1900), 1324.

³ *Ber. Schimmel & Co.*, Oct. (1910), 107.

⁴ *Ber.* **40** (1907), 3321; **43** (1910), 1898.

⁵ *Helv. Chim. Acta* **18** (1935), 355.

⁶ *J. Indian Chem. Soc.* **21** (1944), 270.

⁷ *Ber.* **43** (1910), 446.

β -Santalene

$C_{15}H_{24}$

Mol. Weight 204.34

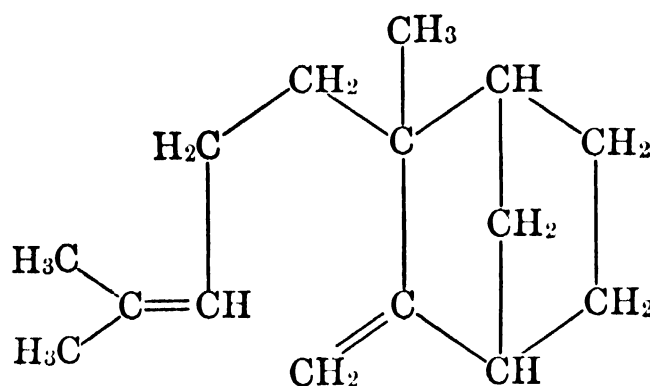

Occurrence.—In East Indian sandalwood oil.

Isolation.—By repeated fractional distillation.

Identification.—With nitrosylchloride, β -santalene yields two nitrosochlorides m. 106° and 152° . These nitrosochlorides give two nitrolpiperidines m. 101° , and 104° – 105° (von Soden ¹).

Properties.—The following properties have been reported for β -santalene by Guerbet,² Semmler,³ Schimmel & Co.⁴ and Ruzicka and Thomann:⁵

b.	263° – 264° ² (corr.)	α_D	$-45^{\circ} 0'$ ⁵
b_9	125° – 127° ³	α_D	$-41^{\circ} 3'$ ⁴
b_7	125° – 126° ⁴	n_D^{20}	1.49460 ⁴
d_{20}	0.892 and 0.894 ^{3, 4}		

For an 88 per cent pure β -santalene, Guha and Bhattacharyya ⁶ reported these properties:

b_7	125°	d_4^{20}	0.8940
$[\alpha]_{5780}$	$-49^{\circ} 54'$ (calc. for pure compound $-56^{\circ} 36'$)	n_D^{20}	1.4941

On treatment with hydrogen chloride, β -santalene gives a dihydrochloride which is probably identical with that obtained from α -santalene.

On hydration, β -santalene yields an alcohol $C_{15}H_{26}O$, b_6 160° – 165° , d_{15} 0.978 (Simonsen ⁷).

On dehydrogenation with sulfur, β -santalene does not give a naphthalene hydrocarbon.

Use.— β -Santalene, as such, is not used in our industries.

¹ *Arch. Pharm.* **238** (1900), 365.

² *Compt. rend.* **130** (1900), 417, 1324. *Bull. soc. chim.* [3], **23** (1900), 217, 540.

³ *Ber.* **40** (1907), 3321; **43** (1910), 1893.

⁴ *Ber. Schimmel & Co.*, Oct. (1910), 107.

⁵ *Helv. Chim. Acta* **18** (1935), 361.

⁶ *J. Indian Chem. Soc.* **21** (1944), 270.

⁷ "The Terpenes," Vol. 2 (1932), 551.

Cedrene

$C_{15}H_{24}$

Mol. Weight 204.34

Despite the researches of many chemists in the past and the thorough investigations of Ruzicka et al.,¹ and Naves and co-workers² in very recent years, the structures of the cedrenes still remain indeterminate. However, present knowledge now recognizes both an "artificial" and "natural" product. The so-called "artificial" hydrocarbon is chemically derived from cedrol by dehydration, whereas the "natural" terpene is obtained as a direct isolate from oil of red cedar wood and is chiefly a mixture of isomeric cedrenes.

Occurrence.—Cedrene has been found, from 60–70 per cent, in American red cedarwood oil (*Juniperus virginiana* L.) by Chapman and Burgess.³ Rutovski, Guseva and Koroleva⁴ found it in *Juniperus polycarpus* Kock.; Kondo⁵ in *Juniperus sinensis* L.; Rutovski and Vinogradova⁶ in *Juniperus excelsa* M.B. = *J. sabina* L. var. *taurica* Tall.; Ikeda and Fujita⁷ in *Cunninghamia konishi* Hayata; Kawamura⁸ in *Sciadopitys verticillata*; Machado, da Silveira and Peixoto⁹ in *Ptorodon pubescens* Benth. and *Borodichia virgilioides* H. Bk.

Isolation.—By fractional distillation and redistillation over metallic sodium.

Identification.—As a preliminary step, determination of the physical properties may be helpful in the identification of cedrene.

A few diagnostic reactions have resulted from the work of Blumann et al.,¹⁰ Treibs,¹¹ Naves et al.,¹² Antoine Chiris,¹³ Semmler et al.,¹⁴ Ruzicka and van Melsen,¹⁵ and Ruzicka et al.¹⁶ These reactions may serve at the present time for possible identification through degradation. Yet the derivatives thus obtained may be of only limited use as they have been developed by various investigators in the course of research on the composition and structure of cedrene which is still being conducted.

The most easily accomplished reaction is the preparation of the cedrene-glycol. The worker interested in the identification of the cedrenes should be aware of the possibility that his tests may be complicated by the presence of isomers, especially *cis*- and *trans*- isomers. These, together with homologous structural types, should account for the parallel development of the *cedrene* vs. *norcedrene* series of derivatives that have been isolated and are illustrated in the diagram.

All figures given for Semicarbazones represent melting point.

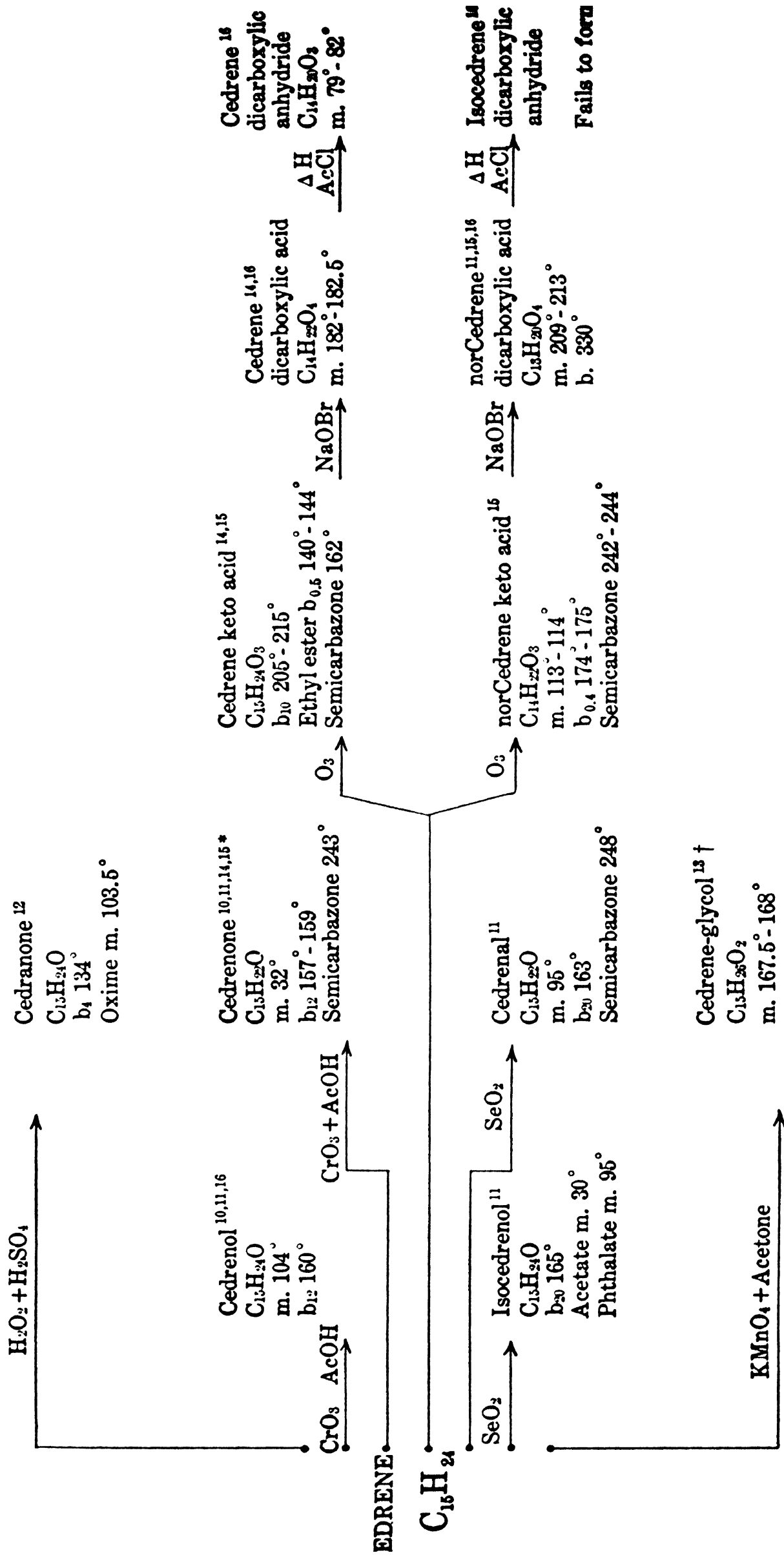

* Referred to by Blumann and Schultz [Ber. 64 (1931), 1540] as *Cedrenone*. More commonly called *Cedrene*.

† Derivative preferred for identification.

Properties.—The following table summarizes the physical properties of cedrene “natural” (a fraction of cedarwood oil) as well as of cedrene “artificial” (resulting from dehydration of cedrol). Both are colorless, syrupy oils.

Treibs,¹⁷ and Naves and co-workers¹⁸ studied the behavior of natural and artificial cedrene toward sulfuric acid (the portion of insoluble product varies) and concluded that the natural cedrene contains a constituent, an isomeric form which, in the artificial cedrene, is only present in very small amounts or not at all. This would explain the difference in physical properties. Notwithstanding this physical difference, chemical reactions prove that the same oxidation products are obtained from artificial cedrene and from natural cedrene. However, the yields of the oxidation products are different when derived from artificial cedrene and from natural cedrene.

The following properties have been reported by Semmler and Mayer,¹⁹ von Soden and Rojahn,²⁰ Treibs,²¹ Semmler and Hoffmann,²² Ruzicka and van Melsen,²³ Glichitch and Naves,²⁴ Naves, Papazian and Perrottet,²⁵ Schimmel & Co.,²⁶ Naves and Perrottet,²⁷ Gildemeister and Hoffmann,²⁸ Blumann and Schulz,²⁹ and Deussen et al.³⁰ The wide variation in α_D for the natural cedrene might well be expected from its nature as a “solution” of sesquiterpenes.

	<i>Natural Cedrene</i>	<i>Artificial Cedrene</i>
b.		264° ²⁶
b ₇₅₀	262°–263° ²⁰	
b ₁₇	129°–132° ²¹	129°–132° ²¹
b _{3.5}	101.5° ²⁵	100° ²⁷
d ₂₀	0.9338–0.9346 ²⁵	0.9340–0.9345 ^{19, 25, 27, 28}
d ₁₅	0.9350–0.9385 ^{20, 28}	0.9366 ^{26, 28}
α_D	–47° 0' to –61° 0' ²⁸	–85° 0' ^{19, 29}
	–52° 48' ²³	–85° 12' ²⁷
	–55° 0' ²²	–85° 32' ²⁶
	–58° 39' to –66° 26' ²⁴	–86° 13' to –86° 18' ²⁵
	–60° 0' to –67° 0' ²¹	
	–60° 52' ²⁰	
	–65° 49' ³⁰	
	–68° 19' to –71° 18' ²⁵	
n _D ²⁰	1.49834–1.50127 ^{22, 24, 25, 28}	1.49798–1.49822 ^{25, 26, 28, 29}

Use.—Cedrene-containing fractions of essential oils, especially of American cedarwood oil, are used for the scenting of soaps and all kinds of technical preparations.

¹ *Helv. Chim. Acta* **25** (1942), 85.

² *Ibid.* **26** (1943), 302.

³ *Proc. Chem. Soc.* (1896), 140.

⁴ *Riechstoff Ind.* **8** (1933), 161.

- ⁵ *J. Pharm. Soc. Japan* (1907), 236. *Ber. Schimmel & Co.*, Oct. (1907), 41.
⁶ *Trans. Sci. Chem. Pharm. Inst. Moscow* **17** (1927), 146.
⁷ *J. Chem. Soc. Japan* **50** (1929), 32. *Chem. Abstracts* **25** (1931), 5506.
⁸ *Bull. Imp. Forestry Expt. Sta. Japan* **31** (1931). *Chem. Abstracts* **26** (1932), 4679.
⁹ *Riv. soc. bras. quim.* **7** (1938), 7, 15. *Chem. Abstracts* **32** (1938), 6396.
¹⁰ *Ber.* **62** (1929), 1697; **64** (1931), 1540.
¹¹ *Ber.* **70B** (1937), 2060.
¹² *Helv. Chim. Acta* **26** (1943), 302.
¹³ *Parfums France* **3** (1925), 168, 353.
¹⁴ *Ber.* **45** (1912), 355, 786, 1384, 1553.
¹⁵ *Liebigs Ann.* **471** (1929), 40.
¹⁶ *Helv. Chim. Acta* **25** (1942), 95.
¹⁷ *Ber.* **68B** (1935), 1041.
¹⁸ *Helv. Chim. Acta* **26** (1943), 302.
¹⁹ *Ber.* **45** (1912), 1384, 1554.
²⁰ *Ber.* **37** (1904), 3353.
²¹ *Ber.* **68** (1935), 1045.
²² *Ber.* **40** (1907), 3521.
²³ *Liebigs Ann.* **471** (1929), 40.
²⁴ *Parfums France* **7** (1929), 86.
²⁵ *Helv. Chim. Acta* **26** (1943), 303.
²⁶ *Ber. Schimmel & Co.*, Oct. (1904), 21.
²⁷ *Helv. Chim. Acta* **24** (1941), 800.
²⁸ "Die Ätherischen Öle," 3d Ed., Vol. I, 393.
²⁹ *Ber.* **64** (1931), 1541. ³⁰ *J. prakt. Chem.* [2], **117** (1927), 295.

The Gurjunenes

C₁₅H₂₄

Mol. Weight 204.34

The oil obtained by the distillation of gurjun balsam, according to Deussen and Philipp,¹ consists of a mixture of two sesquiterpenes, α - and β -gurjunene which Semmler and Spornitz,² and Semmler and Jakubowicz³ separated by prolonged fractionation into approximately 67 per cent of a strongly laevo-rotatory α - isomer and about 33 per cent of a strongly dextrorotatory β - isomer of cedrene type. Both isomers are considered to be tricyclic.

More recently, Treibs⁴ suggested for α -gurjunene the following probable structural formula:

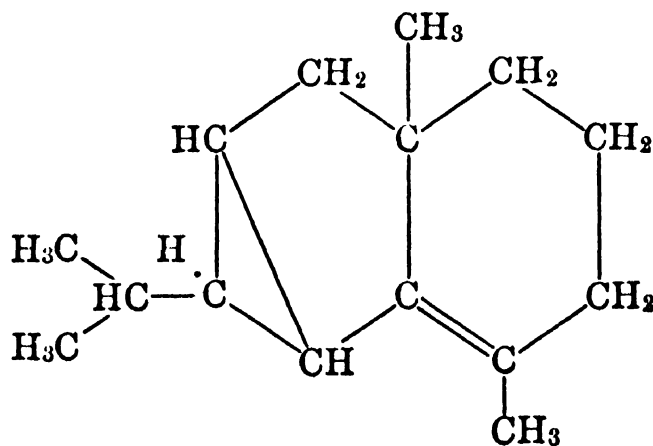

α -Gurjunene (?)

Occurrence.— α - and β -Gurjunene are the principal constituents of the oil distilled by steam from the oleoresin of various *Dipterocarpus* species.

Isolation.—The two isomers cannot be completely separated and purified by mere fractional distillation.

The lower boiling, laevorotatory α -gurjunene thus obtained is fairly pure but not quite free from its β - isomer, as on strong oxidation a sample still gives a small quantity of gurjunene ketone (see below), derived from the β - product, while the α - isomer is completely degraded.

Semmler and collaborators⁶ observed that the higher boiling dextrorotatory β -gurjunene can be obtained in pure form by repeated mild oxidation of the sesquiterpene mixture with chromic acid in acetic acid solution, and finally with potassium permanganate in acetone solution at 0° until no further change in the rotatory power can be observed. The laevorotatory α - form is thereby more easily degraded and only the dextrorotatory β - form remains. (The original laevorotation of the product to be oxidized changes after oxidation to dextrorotation.) The β -gurjunene can finally be obtained pure by distillation over metallic sodium.

Identification.—On oxidation with chromic acid or potassium permanganate, β -gurjunene yields a ketone m. 43°, b_{10} 163°–166°, d_{20} 1.017, α_D +123° 0', n_D 1.52700. This gurjunene ketone $C_{15}H_{22}O$ is isomeric but not identical with cedrone. On reduction with sodium and alcohol, the ketone yields an unsaturated alcohol m. 104°, b_{11} 155°–159°, d 1.001, α_D +34° 0', n_D 1.51859.

Gurjunene ketone can be characterized by the preparation of its semicarbazone m. 237° from which the ketone may be regenerated in solid form by treatment with phthalic anhydride. β -Gurjunene can be regenerated from the semicarbazone of the ketone by reduction with sodium ethylate.

Properties.—The following properties have been reported by Semmler and collaborators:⁶

α -Gurjunene (obtained by repeated fractionation of Gurjun Balsam Oil)

b_{10}	114°–116° ⁶	α_D	–95° 0'; ⁶ –90° (Treibs, see below)
d_{20}	0.918 ⁶	n_D	1.5010 ⁶

Contrary to β -gurjunene, the α - isomer gives the Turner color reaction.⁷

On treatment with hydrogen chloride, α -gurjunene yields a liquid monohydrochloride.

When treating the tricyclic α -gurjunene with hot glacial acetic acid containing sulfuric acid, Treibs⁸ obtained a bicyclic strongly laevorotatory sesquiterpene which he named iso- α -gurjunene.

β -Gurjunene (freed from the α - isomer by careful oxidation)

b_{13}	120°–123° ⁶	α_D	+74° 30' ⁶
d_{20}	0.9348 ⁶		+70° 30' ⁸
		n_D	1.50275 ⁶

On dehydration with sulfur, β -gurjunene, according to Ruzicka, Pontalti and Balas,⁹ does not yield a naphthalene hydrocarbon and therein resembles other tricyclic sesquiterpenes.

Use.—The gurjunenes, as such, are not used in our industries.

- ¹ *Liebigs Ann.* **374** (1910), 105.
² *Ber.* **47** (1914), 1029.
³ *Ber.* **47** (1914), 1141.
⁴ *Ber.* **68** (1935), 1751.
⁵ *Ber.* **47** (1914), 1029, 1141, 2253.
⁶ *Ber.* **47** (1914), 1029, 1141, 2253.
⁷ Cf. *Liebigs Ann.* **374** (1910), 110. *Ber.* **47** (1914), 1142.
⁸ *Ber.* **68** (1935), 1751.
⁹ *Helv. Chim. Acta* **6** (1923), 864.

Longifolene

C₁₅H₂₄

Mol. Weight 204.34

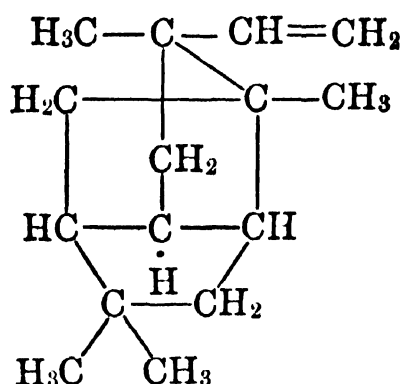

This tricyclic sesquiterpene was first described by Simonsen.¹ Bradfield, Francis and Simonsen² suggested as probable the formula pictured above.

Occurrence.—Longifolene occurs in Indian turpentine oil (*Pinus longifolia*, *P. khasya*, and *P. merkusii*). It has also been reported by Hirao³ in the oil steam distilled from the wood of *Chamaecyparis obtusa*.

Isolation.—By repeated fractional distillation of Indian turpentine oil.

Identification.—Longifolene can be characterized by the preparation of the hydrochloride m. 59°–60°, $[\alpha]_D +7^\circ 6'$ (in chloroform), of the hydrobromide m. 69°–70°, and the hydroiodide m. 71°.

Properties.—*d*-Longifolene is a colorless, somewhat viscid oil with these properties:

b ₇₀₆	254°–256°	$[\alpha]_D$	+42° 44'
b ₃₆	150°–151°	n _D ³⁰	1.4950
d ₃₀ ³⁰	0.9284	Mol. refr.	64.15

Use.—Longifolene is not used in our industries.

- ¹ *J. Chem. Soc.* **117** (1920), 570, 578; **123** (1923), 2642. *Indian Forest Records* **9** (1922), pt. 4; **10** (1923), pt. 4.
² *J. Chem. Soc.* (1934), 188. See Simonsen, *Sci. J. Roy. Coll. Sci.* **4** (1934), 60.
³ *J. Chem. Soc. Japan* **58** (1937), 222. *Chem. Abstracts* **31** (1937), 3468.

SUGGESTED ADDITIONAL LITERATURE

T. F. West, "Indian Turpentine Oil," *Perfumery Essential Oil Record* **29** (1938), 170.

Copaene

 $C_{15}H_{24}$

Mol. Weight 204.34

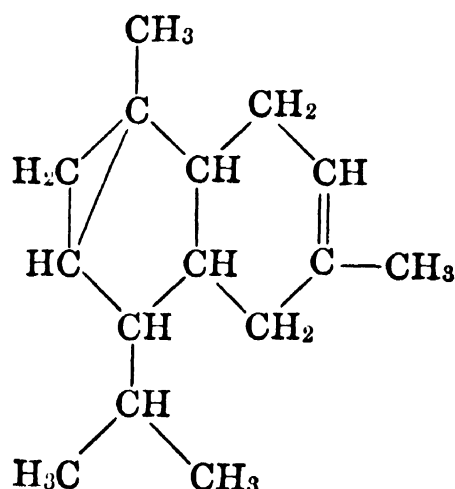

Years ago Semmler and Stenzel¹ found that copaene is a tricyclic sesquiterpene containing one ethylenic linkage, and yielding bicyclic *l*-cadinene dihydrochloride on treatment with hydrogen chloride. Recently Briggs and Taylor² reinvestigated the structure of copaene and arrived at the conclusion that its configuration is actually that pictured above, and not that suggested earlier by Semmler and Stenzel.

Occurrence.—This comparatively rare constituent of essential oils has been observed in the oil of the African copaiba balsam (*Oxystigma mannii* Harms) by Schimmel & Co.;³ in the oil of supa (*Sindora wallichii* Benth.) by Henderson, McNab and Robertson;⁴ to the amount of 70 per cent in oil of papina (*Sindora inermis*) from the Philippines (Davao) by Huzita,⁵ and 35 per cent in the oil from the East Indian mahogany tree (*Cedrela toona*) by Pillai and Rao;⁶ in the oil of *Dysoxylum fraseranum* by Penfold;⁷ and in the oil of the New Zealand tree *Phyllocladus trichomanoides* by Briggs and Sutherland.⁸

Isolation.—By repeated fractional distillation *in vacuo*, separating the fraction b_{10} 114–115° obtained in a 20 plate column.

Identification.—Copaene can be characterized as follows:

- (1) On conducting gaseous hydrogen chloride into an ethereal solution of copaene, laevorotatory cadinene dihydrochloride m. 117–118°, $[\alpha]_D -36^\circ 14'$ is obtained.
- (2) Dehydrogenation of copaene with palladized charcoal yields cadalene.
- (3) Oxidation with ozone or potassium permanganate leads to the monobasic copaene ketonic acid $C_{15}H_{24}O_3$ which can be identified by means of its semicarbazone m. 222°. The methyl ester of this ketonic acid, too, yields a semicarbazone m. 194–196° (Briggs and Taylor⁹).

Properties.—These last named authors, and Schimmel & Co.¹⁰ reported the following properties of copaene:

b.	246–251° ¹⁰	$[\alpha]_D$	$-13^\circ 21'$ ¹⁰
b_{10}	119–120° ¹⁰	$[\alpha]_D^{13.5}$	$-0^\circ 26'$ to $+1^\circ 12'$ ⁹
	114–114.5° ⁹ (20 plate column)	n_D^{25}	1.4880–1.4895 ⁹
d_4^{25}	0.9055 ⁹ (constant)	n_D^{20}	1.48943 ¹⁰
d_{15}^{15}	0.9077 ¹⁰		

Copaene is a colorless viscid oil possessing a faint odor.

Use.—Copaene, as such, is not used in our industries, but the fractions of African copaiba balsam oil containing this sesquiterpene find application in the scenting of soaps, cosmetics and technical preparations.

¹ *Ber.* **47** (1914), 2555.

³ *Ber. Schimmel & Co.*, April (1914), 44.

² *J. Chem. Soc.* (1947), 1338.

⁴ *J. Chem. Soc.* (1926), 3077.

⁵ *J. Chem. Soc. Japan* **62** (1941), 431. *Chem. Abstracts* **36** (1942), 6754.

⁶ *J. Soc. Chem. Ind.* **50** (1931), 220T.

⁷ *J. Proc. Roy. Soc. N. S. Wales* **61** (1928), 337.

⁸ Forthcoming publication.

⁹ *J. Chem. Soc.* (1947), 1338.

¹⁰ *Ber. Schimmel & Co.*, April (1914), 44.

Clovene

C₁₅H₂₄

Mol. Weight 204.34

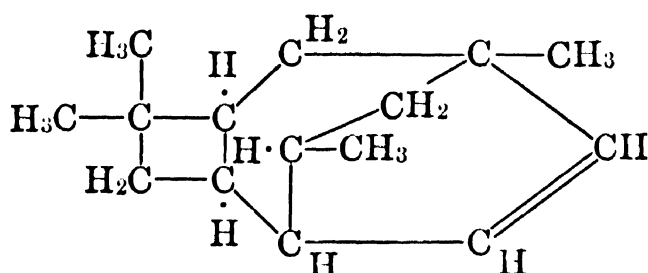

Rydon ¹ suggested the above structural formula for clovene; but this still awaits experimental proof.

Occurrence.—Although this sesquiterpene has not been identified with certainty in volatile oils, it has been detected in residues during several diagnostic operations on the caryophyllene fractions of essential oils (cf. Henderson, McCrone and Robertson ²).

Identification.—No derivatives of clovene have been described; it has, therefore, to be characterized through its properties. Oxidative degradation yields a dicarboxylic acid (Ruzicka and Gibson ³) described as clovenic acid C₁₅H₂₄O₄ m. 182°; anhydride m. 50°–51° and diammonium salt (Blair ⁴) m. 168°–170°.

Properties.—Clovene was first prepared through dehydration of caryophyllene alcohol by Wallach and Walker ⁵ who reported these properties:

b.	261°–263°	n _D ¹⁸	1.50066
d ₁₈	0.930	Mol. refr.	64.77

These figures are in a large measure confirmed in later work by Asahina and Tsukamoto ⁶ and likewise by Henderson, McCrone and Robertson.⁷

Use.—Clovene has not found any use in our industries.

¹ *Chemistry Industry* **57** (1938), 123.

² *J. Chem. Soc.* (1929), 1368.

³ *Helv. Chim. Acta* **14** (1931), 570.

⁴ *J. Chem. Soc.* (1935), 1297.

⁵ *Liebigs Ann.* **271** (1892), 294.

⁶ *J. Pharm. Soc. Japan* No. 484 (1922), 463. *Chem. Abstracts* **16** (1922), 3312.

⁷ *J. Chem. Soc.* (1929), 1368.

Heerabolene

 $C_{15}H_{24}$

Mol. Weight 204.34

Occurrence.—This probably tricyclic sesquiterpene was found by von Friedrichs¹ in heerabol myrrh oil.

Isolation.—By alkaline treatment of the oil-ether extract and fractionation.

Identification.—The only derivative that has been described and by which the sesquiterpene could be in a measure identified is a dichloride m. 98°–99°.

Properties.—Von Friedrichs² reported these properties for heerabolene:

b_{16}	130°–136°	n_D^{20}	1.5125
d_{20}	0.943	Mol. refr.	64.98
α_D^{20}	–14° 12'		

Use.—Heerabolene has not found any use in our industries.

¹ *Arch. Pharm.* **245** (1907), 441.

² *Ibid.*

Vetivene

 $C_{15}H_{24}$

Mol. Weight 204.34

Vetivene, as isolated from vetiver root oil, consists of several bicyclic and tricyclic sesquiterpenes. This mixture of hydrocarbons has been investigated by Genvresse and Langlois,¹ Semmler, Risse and Schröter,² and Ruzicka, Capato and Huyser,³ but the constitution of these sesquiterpenes has not been established.

The bicyclic hydrocarbon isolated has these properties:

b_{12}	132°–133°
d_4^{15}	0.9339
n_D^{15}	1.5179

On dehydrogenation it yields cadalene.

The tricyclic hydrocarbon has these properties:

b_{12}	126°–127°
d_4^{15}	0.9372
n_D^{15}	1.5143

Use.—Vetivene, as such, is not used in our industries.

¹ *Compt. rend.* **135** (1902), 1059.

² *Ber.* **45** (1912), 2347.

³ *Rec. trav. chim.* **47** (1928), 372.

E. DITERPENES

Introduction.—Diterpenes ($C_{20}H_{32}$) seem to occur but occasionally in volatile oils and only a few of the naturally existing diterpenes and derivatives so far have been thoroughly investigated. On the other hand, numerous diterpenes have been prepared synthetically by all kinds of reactions, the discussion of which would not contribute to this study of essential oils.

It will serve our purpose to mention here that natural diterpenes are either highly viscid oils or solids, only sparingly volatile with steam, boiling at about 300° (atmospheric pressure) with a specific gravity (at 20°) ranging usually from 0.92 to 0.95. According to Kondakov and Saprikin,¹ they belong mostly to the hydrogenated naphthalene and phenanthrene derivatives.

The property of low vapor pressure may inhibit the passage of many of these heavier hydrocarbons during distillation of volatile oils, although they do occur as natural ingredients in plants. Their absence in steam distilled oils and their presence in several extracted oils partly explain the marked variance observed in certain properties of a few important products. Thus the role played by these diterpenes may be critical although the natural diterpenes have been less frequently encountered than other hydrocarbons. Moreover, this class of compound is only now being investigated more thoroughly and it remains uncertain how many of the diterpenes and oxygenated derivatives thus far isolated and recorded are actually pure substances. For this reason not too much attention will be devoted in these pages to $C_{20}H_{32}$ compounds and derivatives.

Review articles by Klingemann,² Kondakov and Saprikin,³ and Briggs⁴ merely serve to emphasize the lack of data and knowledge regarding inter-relationship in this field. A study of the literature shows that tentative formulas have been offered only in the case of the camphorenes, phyllocladenes, rimuene and sclareol. However, the worker may occasionally be required to characterize, at this state of our knowledge, other products, described as diterpenes, that are certainly of infrequent occurrence and on which there now exist only the most meager data. In this case reference should be made to the latest literature. These compounds include the α - and β -podocarpenes, totarene, cupressene, mirene, kaurene, α - and β -cryptomerene, "iso"-hydrocarbons, dicitronella oxide (a diterpene product from oil of citronella Java), and even lesser known constituents of essential oils obtained by distillation with superheated steam.

Any data sufficient to merit consideration for diagnostic purposes are summarized in the table facing page 126. However, several diterpenic derivatives already recorded in the literature have not been included in this table because these compounds are either chemically derived from natural wood resins, a class of isolates not connected with this work, or because there ap-

pear at present to be insufficient data to characterize them definitely. Only in the case of the camphorene fractions has any wide technical use been heralded.

¹ *Bull. soc. chim.* [4], **37** (1925), 1045.

² *Z. angew. Chem.* **36** (1923), 317.

³ *Bull. soc. chim.* [4], **37** (1925), 918.

⁴ *Rept. Meeting Australian New Zealand Assocn. Adv. Sc.* **23** (1937), 45.

SUGGESTED ADDITIONAL LITERATURE

C. W. Brandt, "Chemistry of Phyllocladene and Rimuene," *New Zealand J. Sci. Tech.* **20** (1938), 8. *Chem. Abstracts* **33** (1939), 551.

L. Ruzicka and G. Firmenich, "Synthesis of the Aliphatic Diterpene Alcohol, Geranyl Geraniol," *Helv. Chim. Acta* **22** (1939), 392.

L. Ruzicka and E. Bernold, "Degradation of Agathenedicarboxylic Acid with Potassium Permanganate," *Helv. Chim. Acta* **24** (1941), 931.

N. J. Toivonen, V. Alfthan, L. H. Bööck, M. I. Erich and E. K. Heino, "Chemistry of Synthetic Diterpenes. Dimerization of Fenchene with Clay Catalysts: β -Difenchene," *J. prakt. Chem.* **159** (1941), 70. *Chem. Abstracts* **37** (1943), 4064.

L. Ruzicka and L. Sternbach, "Synthesis of 8-Azaretene," *Helv. Chim. Acta* **25** (1942), 1036.

Camphorene

$C_{20}H_{32}$

Mol. Weight 272.46

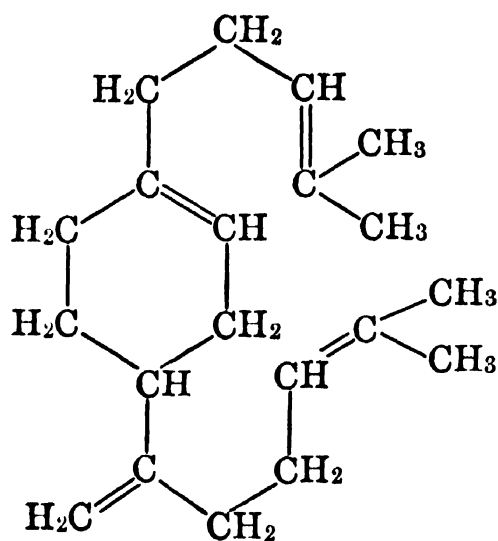

α -Camphorene

According to Semmler and Rosenberg,¹ α -camphorene is a monocyclic diterpene. The structural formula pictured above was advanced by Ruzicka and Stoll;² they found α -camphorene to be a *p*-di-substituted hydrobenzene derivative.

Occurrence.—The highest boiling fractions of camphor oil contain two diterpenes, viz., α -camphorene and β -camphorene.

Isolation.— α -Camphorene can be isolated in pure form from the highest boiling fractions of camphor oil by passing a current of gaseous hydrogen chloride through an ethereal solution of these fractions. The tetrahydrochloride m. 129° – 131° is then decomposed and the α -camphorene regenerated in 98% yield, according to Kafuku,

Oyamada and Nishi,³ by heating for 7 hr. with 10% alcoholic potassium hydroxide. The hydrochloride of β -camphorene is liquid.

Identification.—By the preparation of the tetrahydrochloride (see above), or of the tetrahydrobromide m. 133°–134°, and by determination of the properties of camphorene.

Properties.— α -Camphorene, purified through its tetrahydrochloride, has these properties, according to Ruzicka and Stoll,⁴ Semmler and Rosenberg,⁵ and Kafuku, Oyamada and Nishi:⁶

b_{12}	190°–192° ⁴	α_D	$\pm 0^\circ$ ⁵
b_6	177°–178° ⁵	n_D^{21}	1.4998 ⁶
$b_{4.5}$	178° ⁶	n_D	1.50339 ⁵
d_4^{21}	0.8864 ⁶		
d_{20}	0.8870 ⁵		

β -Camphorene has the following properties:

b_7	170°–180° ⁵	α_D	$\pm 0^\circ$ ⁵
d_{20}	0.930 ⁵	n_D	1.518 ⁵

Use.—Camphorene, as such, has not found any use in our industry, but the high boiling fractions of camphor oil containing this diterpene are widely applied as fixatives in the scenting of soaps and all kinds of technical preparations.

¹ *Ber.* **46** (1913), 768.

² *Helv. Chim. Acta* **7** (1924), 271.

³ *Bull. Chem. Soc. Japan* **8** (1933), 144.

⁴ *Helv. Chim. Acta* **7** (1924), 271.

⁵ *Ber.* **46** (1913), 768.

⁶ *Bull. Chem. Soc. Japan* **8** (1933), 144.

SUGGESTED ADDITIONAL LITERATURE

Kinzo Kafuku, Taichiro Oyamada and Masura Nishi, "A New Diterpene. γ -Camphorene." *Bull. Chem. Soc. Japan* **8** (1933), 144. *J. Chem. Soc. Japan* **54** (1933), 364. *Chem. Abstracts* **27** (1933), 4228.

F. AZULENES

GENERAL PART.

The term "azulene" was introduced by Piesse¹ who suggested it for the blue-colored constituent of chamomile oil. Since then, azulenes have been found in several essential oils—for example, in oil of cubeb, camphor, valerian, galbanum, and wormwood, in the oils of several Eucalyptus species, etc. Oil of chamomile (German and Roman) contains a substantial amount (up to 15 per cent) of azulene.

Azulenenes are blue to violet—even green—colored compounds of various structure. The so-called “natural” azulenes occur in the oils either as such, their presence lending the oils a distinct color, or in the form of colorless sesquiterpene precursors which, by physical or chemical action, can be transformed into colored azulenes. This may be achieved by mere heating, by treatment with acids, by dehydration, or dehydrogenation.

The azulenes have been the object of numerous investigations but it is only recently that the constitution of some of these highly interesting compounds was elucidated. The terms chosen for the various azulenes are derived from the names of the plants in which these complex hydrocarbons occur, or from which they are obtained chemically. We thus speak of chamazulene (from the Latin word *Chamomilla* for camomile), of vetivazulene (from vetiver oil), of guaiazulene (obtained by dehydration and dehydrogenation of guaiol), and elemazulene (by chemical treatment of elemol). The fungus of the true orange agaric (*Lactarius deliciosus* L.) contains lactarazulene and verdazulene, the latter named after its green color. The various azulenes can be distinguished by their color which is either pure blue, blue-violet, violet, red-violet, or even green (verdazulene). In case the azulenes are obtained by dehydration (or dehydrogenation), the method thereby employed may influence the color of the azulene. For example, dehydration and dehydrogenation of guaiol with sulfur yield the pure blue S-guaiazulene, and like treatment with selenium produces the violet Se-guaiazulene. Several azulenes obtained from various essential oils by dehydrogenation belong to the type guaiazulene. The exact constitution of cham-, lactar-, elem- and Se-guaiazulene remains unknown. In pure form most azulenes are well crystallized substances, their melting points ranging from 40°–100°.

According to Plattner and Pfau,² the parent substance of all azulenes is a bicyclic hydrocarbon C₁₀H₈, commonly called “azulene” (m. 98.5°–99°), of the following formula:

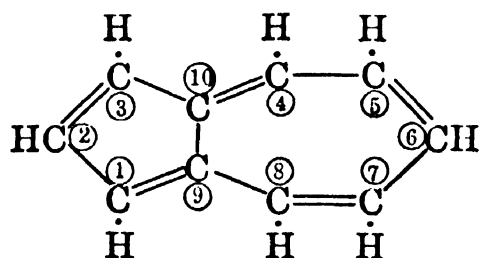

Trinitrobenzene derivative m. 166.5°–167.5°; trinitrotoluene derivative m. 99.5°–100°. In regard to its physical and chemical behavior, the parent azulene shows many analogies with the isomeric naphthalene. The carbon skeleton of this hydrocarbon presents a combination of a completely conjugated five-membered ring with a seven-membered ring, which feature in part accounts for the strong absorption of light displayed by the azulenes.

The azulenes are closely related to the sesquiterpenes, both types of hydrocarbons possessing the empirical molecular formula C₁₅H₁₈. These hydrocarbons may be formed in nature possibly by cyclization of a previously formed chain of three isoprene molecules, according to Ruzicka's³ farnesol

hypothesis. Ruzicka and collaborators and the Swiss school of workers,⁴ in general, have contributed most of our present-day knowledge pertaining to azulenes. Thus, Ruzicka, Rudolph and Haagen-Smit⁵ investigated chamazulene, guaiazulene, Se-guaiazulene, and elemazulene. Pfau and Plattner⁶ isolated vetivazulene from vetiver oil and, along with Coats and Cook,⁷ synthesized this terpene and elucidated its constitution. The most convincing proof for the relationship between sesquiterpenes and azulenes is given by the fact that several sesquiterpenes and sesquiterpene derivatives can be dehydrogenated or dehydrated to azulenes. Thus vetivone yields vetivazulene, while guaiol, ledol, and aromadendrene give guaiazulene, according to the following scheme:

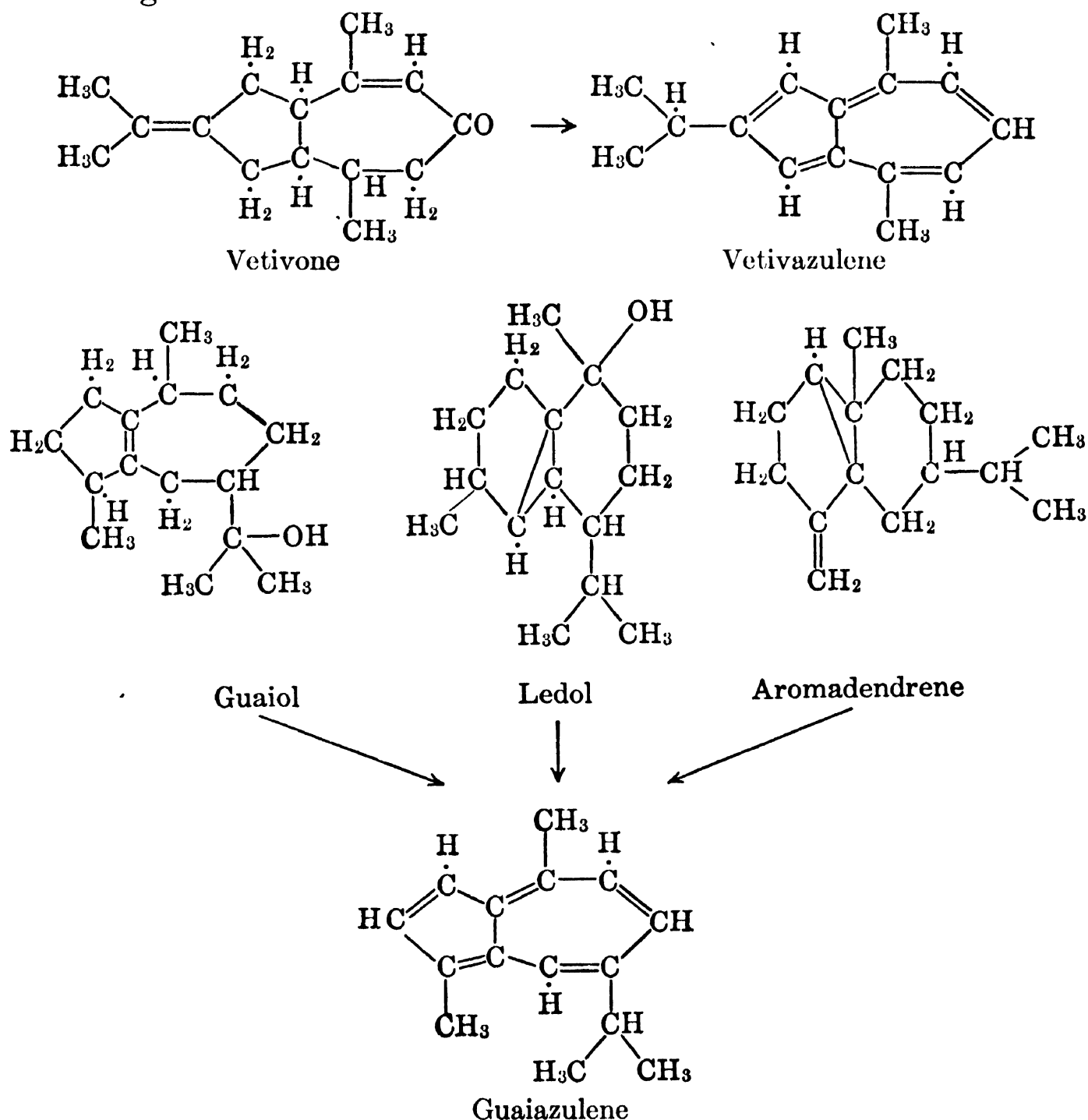

In the case of vetivone and guaiol, the carbon skeleton of the corresponding azulenes is already present, the formation of azulene taking place by mere dehydrogenation, but the formation of guaiazulene from the tricyclic ledol must be explained, according to Komppa and Nyman,⁸ by bursting of the trimethylene-ring and simultaneous formation of the five- and seven-mem-

bered ring system of guaiazulene. A similar transformation of the ring system takes place, according to Radcliffe and Short,⁹ when aromadendrene is dehydrogenated to guaiazulene.

A number of azulenes have been synthesized by various methods and by several workers, among them Pfau and Plattner,¹⁰ Plattner and co-workers,¹¹ Wagner-Jauregg and collaborators,¹² Coats and Cook,¹³ and Arnold.¹⁴ For details the reader is referred to the original literature and to reviews by Hüter,¹⁵ "Natural and Synthetic Azulenes" (in German), and by Arnold,¹⁶ "The Azulenes" (in German).

Isolation and Identification.—The azulenes can be isolated and purified by several methods:

One of the oldest and most practical is that developed by Sherndal¹⁷ for the isolation of azulenes from oil of cubeb and camphor. This method is based upon the fact that the azulenes react readily with strong mineral acids, such as phosphoric or sulfuric acid, forming thereby addition compounds. These can easily be decomposed with water whereby the azulenes are regenerated. Thus an addition product of azulenes can be prepared by shaking a well-cooled solution of azulenes in petroleum ether with 85% phosphoric acid. On dilution with ice water, the pure azulenes will separate from the phosphoric acid layer.

Herzenberg and Ruhemann,¹⁸ and Ruhemann and Lewy¹⁹ suggested shaking the azulenes with an aqueous solution of ferrocyanic acid; the ferrocyanate thus formed can be decomposed with a dilute solution of sodium hydroxide and the azulene regenerated.

Sherndal,²⁰ and Ruzicka and Rudolph²¹ recommended the use of picrates and styphnates for the isolation and characterization of azulenes. Like the trinitrotoluene (trotylates) and trinitrobenzene derivatives of the azulenes, the picrates and styphnates are crystalline compounds of sharp melting points from which the azulenes can be regenerated in pure form—for example, from the picrates by treatment with dilute alkalis. The trotylates and trinitrobenzoates are prepared by heating the azulenes with excess trinitrotoluene or trinitrobenzene and alcohol, by cooling, and recrystallization from alcohol.

A more modern and milder method, introduced by Plattner and Pfau,²² is the chromatographic separation of the trinitrobenzene compounds when dissolved in cyclohexane and filtered through an aluminum oxide column. It lends itself particularly well to the more sensitive azulenes.

Kaiser and Frey²³ suggested for the isolation of chamazulene from chamomile oil a combination of the ferrocyanic acid and chromatographic methods.

These same authors²⁴ also described a colorimetric method by which the content of pure azulene can be determined in the fluid extracts and in the volatile oil of chamomile.

Highly characteristic of the azulenes are their absorption spectra which lie in the visible field. The measuring of these spectra, as carried out by Susz, Pfau and Plattner²⁵ on azulene, vetivazulene, and S-guaiazulene, and by Willstaedt²⁶ on guai-, lactar-, and chamazulene have been of great help in the determination of the number and position of substituents in the azulene ring system. For details the reader is referred to the comprehensive paper by Plattner, "Constitution and Color of the Azulenes."²⁷ Plattner thus was able to classify the azulenes into three groups. The practical value of correlation between light absorption, number, and position of the substituents can be seen from this example:

As pointed out above, dehydration or dehydrogenation of guaiol or guaiene, according to the method applied (sulfur or selenium), yields either a blue or a violet azulene.

The blue S-guaiazulene is a 1,4-dimethyl-7-isopropyl-azulene. Vetivazulene is a 4,8-dimethyl-2-isopropyl-azulene and, in regard to its absorption spectra, closely resembles the violet Se-guaiazulene. The latter, contrary to S-guaiazulene, therefore carries one substituent, probably in the 2-position. Plattner²⁸ thus came to the conclusion that the dehydrogenation of guaiene with selenium is connected with a migration of the methyl group from the 1-position to the 2-position.

From the foregoing, it becomes evident that the measuring of the absorption spectra permits a much clearer insight into the constitution of the delicate azulenes than chemical degradation. Oxidative degradation, for example, yields substances of such low order that conclusions as to the original structure of the azulene can no longer be drawn.

According to Plattner,²⁹ the color of azulene cannot be predicted from a comparison of its formula with those of similarly constituted compounds in the naphthalene and fulvene series. The five successive conjugated double linkages of azulene which permit it to be regarded as a mesomeric system are, however, in complete accordance with its optical properties.

From the optical measurements of Plattner, far reaching and interesting conclusions as to the as yet unknown constitution of cham-, lactar-, and Se-guaiazulenes can be made, and this method can also be employed for the identification of the azulenes.

Use.—The azulenes, as such, are not used in our industries, but further research may well find a place for some of the azulenes in medicinal preparations.

- ¹ *Compt. rend.* **57** (1863), 1016. *Chem. News* **8** (1863), 245, 273.
- ² *Helv. Chim. Acta* **20** (1937), 224. *Chem. Abstracts* **31** (1937), 4284.
- ³ *Angewandte Chemie* **51** (1938), 5.
- ⁴ See Pfau and Plattner, *Helv. Chim. Acta* **19** (1936), 858. Plattner and Pfau, *ibid.* **20** (1937), 224. Plattner and collaborators, *ibid.* **20** (1937), 469; **23** (1940), 897, 907; **24** (1941), 191, 283E, 483; **25** (1942), 581. Willstaedt, *Ber.* **69B** (1936), 997.
- ⁵ *Helv. Chim. Acta* **9** (1926), 120; **14** (1931), 1104.
- ⁶ *Ibid.* **19** (1936), 858, 861.
- ⁷ *J. Chem. Soc.* (1942), 559.
- ⁸ *C. R. Trav. Lab. Carlsberg, Ser. chim.* **22** (1938), 272.
- ⁹ *J. Chem. Soc.* (1938), 1200.
- ¹⁰ *Helv. Chim. Acta* **19** (1936), 866; **20** (1937), 224; **22** (1939), 202.
- ¹¹ *Ibid.* **23** (1940), 897, 907; **24** (1941), 483; **25** (1942), 581, 590, 1077; **26** (1943), 905.
- ¹² *Ber.* **74B** (1941), 1522; **75B** (1942), 1293; **76B** (1943), 694, 1157.
- ¹³ *J. Chem. Soc.* (1942), 559.
- ¹⁴ *Ber.* **76B** (1943), 777.
- ¹⁵ *Deut. Parfümerieztg.* **28** (1942), 153.
- ¹⁶ "Die Chemie," **56** (1943), 7.
- ¹⁷ *J. Am. Chem. Soc.* **37** (1915), 167, 1537.
- ¹⁸ *Ber.* **58** (1925), 2249.
- ¹⁹ *Ber.* **60** (1927), 2459.
- ²⁰ *J. Am. Chem. Soc.* **37** (1915), 167, 1537.
- ²¹ *Helv. Chim. Acta* **9** (1926), 118, 132, 133.
- ²² *Ibid.* **20** (1937), 230, 231.
- ²³ *Deut. Apoth. Ztg.* **53** (1938), 1385, 1402.
- ²⁴ *Ibid.* **54** (1939), 882; **57** (1942), 155, 163. *Chem. Abstracts* **37** (1943), 5548.
- ²⁵ *Helv. Chim. Acta* **20** (1937), 469.
- ²⁶ *Ber.* **69** (1936), 999.
- ²⁷ *Helv. Chim. Acta* **24** (1941), 283E.
- ²⁸ *Ibid.*
- ²⁹ *Ibid.*

SUGGESTED ADDITIONAL LITERATURE

Harry Willstaedt (Univ. Stockholm), "Fungus Dyes. Two New Fat-soluble Dyes from Genuine Orange Agaric (*Lactarius deliciosus* L.)," *Svensk. Kem. Tid.* **58** (1946), 81 (in German). *Chem. Abstracts* **40** (1946), 6460.

P. A. Plattner, A. Fürst, J. Wyss and R. Sandrin, "2-Isopropyl-Azulen," *Helv. Chim. Acta* **30** (1947), 689.

P. A. Plattner and E. Heilbronner, "Die Absorptionskurven des Azulens und der fünf Monomethyl-azulene im sichtbaren Bereich," *ibid.*, 910.

E. Heilbronner and K. Wieland, "Spektrographische und thermochemische Untersuchungen an dampfförmigem Azulen," *ibid.*, 947.

P. A. Plattner, A. Fürst and A. Studer, "Über neuere Synthesen des 5-Methyl-azulens," *ibid.*, 1091.

P. A. Plattner, E. Heilbronner and A. Fürst, "Die spektroskopische Prüfung verschiedener Präparate von 5-Methyl-azulen," *ibid.*, 1100.

P. A. Plattner, A. Fürst and K. Jirasek, "Im Fünfring mehrfach substituierte Azulene," *ibid.*, 1320.

J. H. Clark, "The Azulenes," *Am. Perfumer* **51** (1948), 38.

P. A. Plattner and E. Heilbronner, "Die Ultraviolett-Absorptionsspektren der fünf Monomethyl- und einiger mehrfach substituierter Azulene," *Helv. Chim. Acta* **31** (1948), 804.

SPECIAL PART—INDIVIDUAL AZULENES.

Briefly we shall describe some of the so-called "natural" azulenes (see also above); others will be discussed under the essential oils in which they occur.

Chamazulene

$C_{15}H_{18}$

Mol. Weight 198.29

The structural formula of chamazulene has not yet been definitely established, neither has this azulene been prepared synthetically.

Occurrence.—Blue azulene fractions from essential oils, described as similar to the colored hydrocarbon from chamomile, have been reported in a summary by Wolf ¹ and Hüter ² as derived from a number of sources. However, chamazulene is most frequently encountered in oil of chamomile, imparting to it the characteristic blue color. Kaiser and Frey ³ reported that this azulene, in terms of their new colorimetric method, should be present in chamomile oil to the extent of 1 per cent, and in the oil distilled from prime, fresh flowers from 1.3 to 1.5 per cent. An oil distilled from dried Spanish chamomile flowers contained 15.2 per cent azulene, from German (Taunus) flowers 12.3 per cent, from Hungarian flowers 4.8 per cent.

Ruhemann and Lewy ⁴ came to the conclusion that chamazulene does not exist preformed in the plant but is possibly formed from the sesquiterpenes by enzyme action. A similar view was expressed by Koch ⁵ who found that,

contrary to the observations of other authors, chamazulene is not present in chamomile flowers as azulene but in some other form. Graham ⁶ came to the same conclusion about milfoil.

Isolation.—By the methods described in the general part on azulenes. A solution of chamazulene can be prepared by chromatography, on aluminum oxide, of a petroleum ether solution of chamomile oil.

Identification.—According to Ruzicka and Rudolph ⁷ and Ruzicka and Haagen-Smit,⁸ chamazulene may be characterized by the preparation of a picrate m. 115° (120°, according to Müller ⁹), and a styphnate m. 95°–96°. Pfau and Plattner ¹⁰ reported m. 132° for the trinitrobenzene compound of chamazulene.

Properties.—Ruzicka and Haagen-Smit ¹¹ found these properties of chamazulene:

b ₁₁	159°
d ₄ ¹⁸	0.9881
d ₄ ¹⁵	0.991

Use.—Chamazulene, as such, is not used, but infusions and fluidextracts of chamomile flowers have been a well-known household medicine for a long time, as chamazulene has a strong anti-inflammatory action, a fact established by Heubner and collaborators,¹² by Arnold,¹³ and by Jaretzki and Neuwald.¹⁴ Indeed, the anti-inflammatory action of chamomile oil seems to be due entirely to one constituent, viz., chamazulene, according to the work of Pommer.¹⁵

¹ *Fette u. Seifen* **47** (1940), No. 3, 122.

² *Deut. Parfümerieztg.* **28** (1942), 153.

³ *Deut. Apoth. Ztg.* **54** (1939), 882; **57** (1942), 155, 163. *Chem. Abstracts* **37** (1943), 5548.

⁴ *Ber.* **60** (1927), 2459.

⁵ *Arch. Pharm.* **280** (1942), 424.

⁶ *J. Am. Pharm. Assocn.* **22** (1933), 819.

⁷ *Helv. Chim. Acta* **9** (1926), 118.

⁸ *Ibid.* **14** (1931), 1104.

⁹ *J. prakt. Chem.* **156** (1940), 184.

¹⁰ Private communication to Willstaedt, *Ber.* **69B** (1936), 997.

¹¹ *Helv. Chim. Acta* **9** (1926), 118; **14** (1931), 1104.

¹² *Arch. exptl. Path. Pharmacol.* **171** (1933), 329; **192** (1939), 383; **193** (1939), 619.

¹³ *Ibid.* **123** (1927), 129.

¹⁴ *Arch. Pharm.* **277** (1939), 50.

¹⁵ *Arch. exptl. Path. Pharmacol.* **199** (1942), 74. *Chem. Zentr.* I (1942), 3227.

Vetivazulene

C₁₅H₁₈

Mol. Weight 198.29

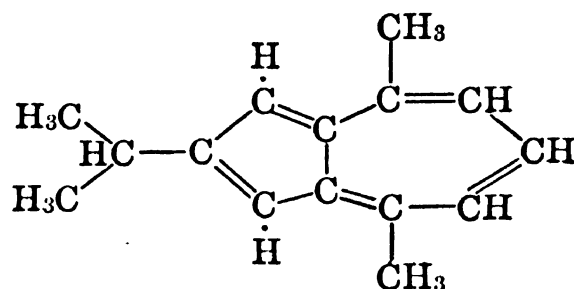

Vetivazulene

The experimental work leading to the synthesis and formulation of the structure of vetivazulene was carried out by Pfau and Plattner,¹ and Coats and Cook.²

Occurrence and Isolation.—Vetivazulene can be obtained by dehydrogenating the fraction b₁ 140°–160° of Java vetiver oil with selenium (see also general description of the azulenes).

Identification.—According to Pfau and Plattner,³ vetivazulene may be characterized by the preparation of these derivatives:

Picrate	m. 121.5°–122°
Trinitrobenzoate	m. 151.5°–152°
Trotylate	m. 80.5°–81°.

Properties.—The same authors also reported for crude vetivazulene: b₂ 140°–180°, m. 32°–33°.

Use.—Vetivazulene is not used in our industries.

¹ *Helv. Chim. Acta* **19** (1936), 858; **20** (1937), 224, 469; **22** (1939), 202.

² *J. Chem. Soc.* (1942), 559.

³ *Helv. Chim. Acta* **19** (1936), 858; **20** (1937), 224, 469; **22** (1939), 202.

Guaiazulene

C₁₅H₁₈

Mol. Weight 198.29

As pointed out in the general description of azulenes, dehydration of guaiol or dehydrogenation of guaiene, according to the method employed (sulfur or selenium), yields either the blue S-guaiazulene or the violet Se-guaiazulene. Birrell¹ expressed the opinion that Se-guaiazulene is probably identical and not isomeric with S-guaiazulene, but this view, in the light of later work, seems rather questionable.

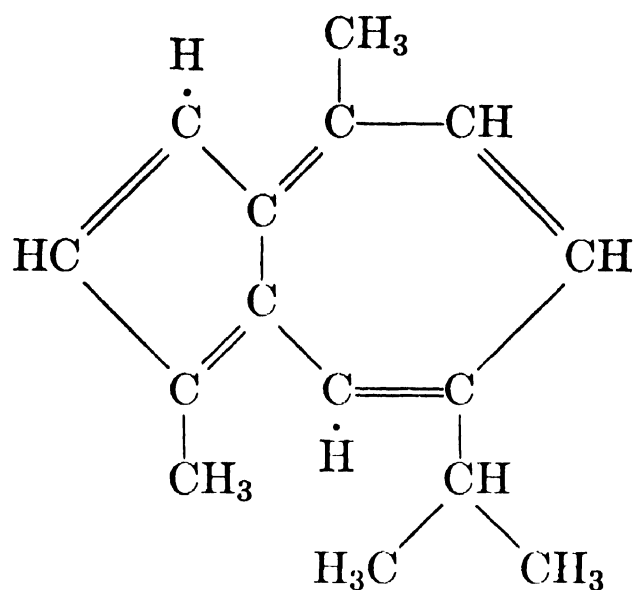
S-Guaiazulene

(Kessazulene), (Gurjunazulene), (Eucazulene)

This structural formula of *S*-guaiazulene was established by Pfau and Plattner.² The same authors also showed that *S*-guaiazulene is identical with eucazulene (from eucalyptus oil). Previously, Ruzicka and Haagen-Smit³ had proved that the "kessazulene" obtained by Asahina and Nakanishi⁴ from kessyl alcohol is identical with *S*-guaiazulene. Shortly afterward, Asahina and collaborators⁵ confirmed that "kessazulene" and guaiazulene have similar properties.

Occurrence and Isolation.—By repeated fractionation, Pfau and Plattner⁶ isolated the higher boiling portions of oil of *Eucalyptus globulus* Labill., gurjun balsam, Réunion geranium, *Geranium macrorrhizum* L., and patchouly, and on dehydrogenation with sulfur obtained *S*-guaiazulene. The product of dehydrogenation was extracted with ether and distilled. A solution of the distillate in 5 volumes of petroleum ether was shaken at low temperature with 95% phosphoric acid until decolorized. After repeated washing with ether, peroxide-free ether was added to the phosphoric acid extract, the *S*-guaiazulene liberated by addition of ice water, and steam distilled. Distillation over metallic sodium gave practically pure *S*-guaiazulene (about 16% of the oil used). Purification was also accomplished by chromatographic passage of a solution of the crude product in petroleum ether over aluminum oxide (Al₂O₃).

Taira⁷ prepared *S*-guaiazulene from the sesquiterpene alcohol isolated from fusel oil of cane molasses and sweet potatoes.

Identification.—From *S*-guaiazulene, Pfau and Plattner⁸ prepared the picrate m. 122°–122.5°, the styphnate m. 105°–106°, both stable only in the presence of excess reagent. The same authors, furthermore, described the trinitrobenzene derivative m. 151°–151.5°, and the trinitrotoluene derivative m. 89°. The latter two compounds are more stable and better suited for purification and identification of *S*-guaiazulene and are readily decomposed by ammonium sulfide.

Properties.—Ruzicka and collaborators⁹ reported for *S*-guaiazulene these properties:

b ₁₂	167°–168°	d ₄ ¹⁹	0.9728
b ₁₁	164°	d ₄ ¹⁸	0.9759

According to Birrell,¹⁰ S-guaiazulene forms blue-violet orthorhombic plates, b_{17} 176° , m . 31.5° .

Se-Guaiazulene

The absorption spectrum of Se-guaiazulene closely resembles that of vetivazulene. Plattner,¹¹ therefore, came to the conclusion that during the dehydrogenation of guaiane with selenium, thermal rearrangements take place by which the methyl group moves from the 1-position (in guaiazulene) to the 2-position.

The structural formula of Se-guaiazulene is not definitely established but it is possibly 2,4-dimethyl-7-isopropyl-azulene.

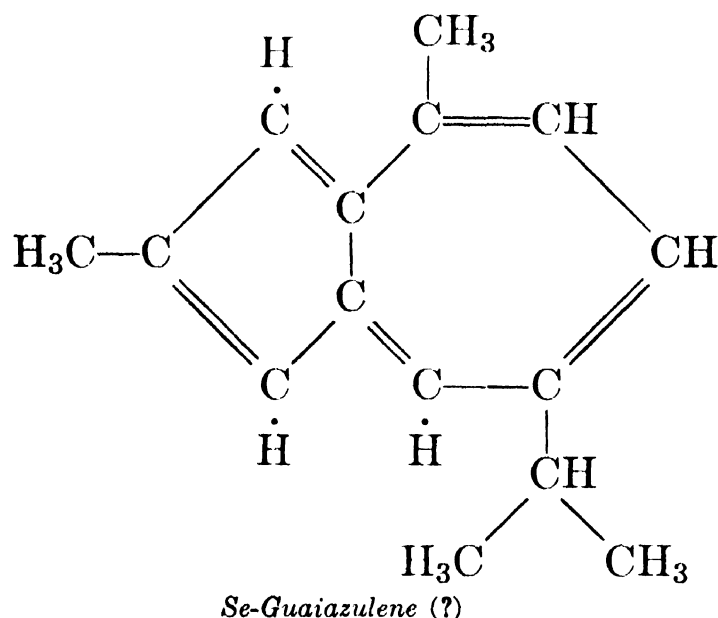

Ruzicka and Haagen-Smit¹² reported for Se-guaiazulene b_{13} 170° – 171° , d_4^{21} 0.9706. It forms a picrate m . 114° – 115° , 110° and a styphnate m . 92° , 83° .

Use.—The guaiazulenes are not used in our industries.

¹ *J. Am. Chem. Soc.* **56** (1934), 1248.

² *Helv. Chim. Acta* **19** (1936), 858.

³ *Ibid.* **14** (1931), 1104.

⁴ *J. Pharm. Soc. Japan* **48** (1928), 1.

⁵ *Ibid.* **52** (1932), 1.

⁶ *Helv. Chim. Acta* **19** (1936), 858.

⁷ *J. Agr. Chem. Soc. Japan* **11** (1935), 594. *Chem. Abstracts* **29** (1935), 7007.

⁸ *Helv. Chim. Acta* **19** (1936), 858.

⁹ *Ibid.* **9** (1926), 134; **14** (1931), 1112.

¹⁰ *J. Am. Chem. Soc.* **56** (1934), 1248; **57** (1935), 893.

¹¹ *Helv. Chim. Acta* **24** (1941), 283E.

¹² *Ibid.* **14** (1931), 1115.

SUGGESTED ADDITIONAL LITERATURE

Sébastien Sabetay and Hermine Sabetay, "A Color Reaction for Azulene Sesquiterpenes," *Compt. rend.* **199** (1934), 313. *Chem. Abstracts* **28** (1934), 6721.

Kenneth S. Birrell, "Investigation of Azulenes," *J. Am. Chem. Soc.* **57** (1935), 893. *Chem. Abstracts* **29** (1935), 4354.

B. Susz, Alexandre St. Pfau and Pl. A. Plattner, "Volatile Plant Constituents. Absorption Spectra of Azulene, Guaiazulene and Vetivazulene," *Helv. Chim. Acta* **20** (1937), 469. *Chem. Abstracts* **31** (1937), 5681.

Alfred L. Sklar, "Theory of Color of Organic Compounds." *J. Chem. Phys.* **5** (1937), 669. *Chem. Abstracts* **31** (1937), 7758.

Arno Müller, "Test for Terpene Chromogens, Especially Azulenogenic Compounds and a New Color Reaction for Ethereal Oils," *J. prakt. Chem.* **151** (1938), 233. *Chem. Abstracts* **33** (1939), 1880.

Pl. A. Plattner and L. Lemay, "Sesquiterpenes. Carbon Skeleton of Guaiacol and of Guaiazulene," *Helv. Chim. Acta* **23** (1940), 897. *Chem. Abstracts* **34** (1940), 7884.

E. Perrottet, W. Taub and E. Briner, "Comparative Energy States of Azulenic and Naphthalenic Nuclei," *Helv. Chim. Acta* **23** (1940), 1260. *Chem. Abstracts* **35** (1941), 2497.

K. Koch, "Azulene Content of Yarrow and Its Colorimetric Estimation," *Deut. Apoth. Ztg.* **55** (1940), 758. *Chem. Abstracts* **35** (1942), 2674.

Milton S. Schechter and H. L. Haller, "The Formation of an Azulene on Zinc-Dust Distillation of Pyrethrosin," *J. Am. Chem. Soc.* **63** (1941), 3507.

Y. R. Naves, "Recent Developments in the Chemistry of Odorous Substances Derived from Hydroazulenes," *Parfumerie* **1** (1943), 70. *Chem. Abstracts* **40** (1946), 3228.

Pl. A. Plattner and A. Fürst, "Zur Kenntnis der Sesquiterpene. Über den Einfluss der Substitution auf die Farbe der Azulene; 2-Äthyl-azulen," *Helv. Chim. Acta* **28** (1945), 1636.

Pl. A. Plattner, A. Fürst and H. Schmid, "Zur Kenntnis der Sesquiterpene. Über den Einfluss der Substitution auf die Farbe der Azulene; 1, 3, 4, 8-Tetramethyl-azulen," *Helv. Chim. Acta* **28** (1945), 1647.

P. Karrer, H. Ruckstuhl and E. Zbinden, "Über Lactaroviolin, einen Farbstoff aus *Lactarius deliciosus*," *Helv. Chim. Acta* **28** (1945), 1176.

Pl. A. Plattner, A. Fürst und K. Jirasck, "Über eine neue Azulen-Synthese," *Helv. Chim. Acta* **29** (1946), 740.

Pl. A. Plattner und A. Studer, "Zur Kenntnis der Sesquiterpene. Über 6-Methyl-azulen," *Helv. Chim. Acta* **29** (1946), 1432.

Pl. A. Plattner und G. Buchi, "Über eine einfache, von Cycloheptanon ausgehende Azulen-Synthese," *Helv. Chim. Acta* **29** (1946), 1608.

Pl. A. Plattner, A. Fürst, and K. Jirasek (Tech. Hochschule, Zürich), "Sesquiterpenes. Bicyclo-[5, 3, 0]-decane," *Helv. Chim. Acta* **29** (1946), 730 (in German). *Chem. Abstracts* **40** (1946), 4701.

Pl. A. Plattner, R. Sandrin, and J. Wyss, "2-Phenylazulene. The Migration of Substituents on the Azulene Nucleus," *Helv. Chim. Acta* **29** (1946), 1604 (in German). *Chem. Abstracts* **41** (1947), 2026.

Hermann Hippchen, "The Preparation of an Azulene of the Guaiazulene Type from *m*-Cymene," *Z. Naturforsch.* **1** (1946), 325. *Chem. Abstracts* **41** (1947), 5497.

Pl. A. Plattner and E. Heilbronner, "Die Absorptionskurven des Azulens und der fünf Monomethyl-azulene im sichtbaren Bereich," *Helv. Chim. Acta* **30** (1947), 910.

E. Heilbronner and K. Wieland, "Spektrographische und thermochemische Untersuchungen an dampfförmigem Azulen," *Helv. Chim. Acta* **30** (1947), 947.

F. Šorm and J. Fajkoš (Inst. of Technol., Prague, Czechoslovakia), "The Synthesis of 6-Methylazulene," *Collection Czech. Chem. Commun.* **12** (1947), 81. *Chem. Abstracts* **41** (1947), 4140.

Pl. A. Plattner, A. Fürst and K. Jirasek, "Im Fünfring mehrfach substituierte Azulene," *Helv. Chim. Acta* **30**, No. 5 (1947), 1320.

II. ALCOHOLS

A. ALIPHATIC ALCOHOLS

Introduction.—Essential oils contain only a few saturated monohydroxy alcohols of the paraffin series, most of them being esterified with fatty acids. The lower members occurring in free form are probably formed by the hydrolysis of esters in the course of steam distillation. This is equally true of the lower fatty acids occasionally found in volatile oils. The lowest members of the saturated aliphatic alcohols, especially methyl alcohol, frequently occur in the distillation waters of volatile oils, and are often associated with furfural and diacetyl. It may be assumed that these substances are formed by degradation of complex but unstable carbon compounds in the plant material during distillation. Because of their great solubility, they readily dissolve in the distillation water. Therefore, they do not usually occur in the separating direct oil, but may accumulate in the oil of cohobation which is obtained by redistillation of the distillation water. This holds true also of ethyl alcohol which may be a product of fermentation of plant starches previous to distillation. Similar phenomena have been observed in the case of rose distillation if the petals have undergone a slight fermentation.

Aliphatic alcohols may be isolated from essential oils by fractional distillation, some through their calcium chloride compounds, others through the acid phthalates, or *p*-hydroxybenzoates. They are identified by the preparation of crystalline derivatives such as phenylurethanes, naphthylurethanes, allophanates, *p*-nitrobenzoates, 3,5-dinitrobenzoates, etc.

(a) SATURATED ALIPHATIC ALCOHOLS.

CH_4O	Methyl Alcohol	Mol. Weight 32.04
	Methanol	
	$\text{CH}_3 \cdot \text{OH}$	

Occurrence.—Methyl alcohol occurs in the distillation waters of many volatile oils, and also in the oils of cohobation.

Isolation.—By fractional distillation. As methyl alcohol does not form a constant boiling mixture with water, it may be concentrated effectively by this means. From aqueous solutions the alcohol can be salted out with potassium carbonate. Pesce¹ recommends that final purification be made by distillation from calcium hydride.

Identification.—Methyl alcohol can be characterized by the preparation of numerous derivatives, among which the following are most useful:

(1) *p*-Nitrobenzoate m. 96° (crystallized from dilute alcohol), according to Henstock.² Methyl alcohol can thus be detected in a 0.25% aqueous solution.

(2) 3,5-Dinitrobenzoate m. 108° (crystallized from 95% alcohol or petroleum ether), according to Bryant.³ Lipscomb and Baker⁴ reported that this reagent may be effectively used to identify methanol in solution without necessity of isolation *per se*, when the alcohol arises in the saponification process.

(3) Acid phthalate m. 82.4° – 82.7° (corr.), according to Goggans and Copenhaver.⁵

(4) To identify methanol in small quantities, Gakenheimer and Hartung⁶ recommend mixing, dropwise, solutions of 5% phosphoric acid, 5% potassium permanganate, and the test solution. The mixture is allowed to stand a minute and is then decolorized with a little solid sodium bisulfite, after which 4 cc. of 72% sulfuric acid and a little finely powdered chromotropic acid are added. The mixture is well shaken and heated to 60° for 10 min. A violet color, intensifying on cooling, indicates the presence of as much as 0.1% methanol.

Properties.—The following properties are those listed in the International Critical Tables,⁷ and reported by Pesce,⁸ and Wojciechowski:⁹

m.	-94.9° ⁷	n_{5876}^{25}	1.32643 ⁸
b.	64.509° ⁹	$n_D^{20.5}$	1.32875 ⁷
d_4^{25}	0.78662 ⁸	$n_D^{14.5}$	1.33118 ⁷
d_4^{20}	0.79134 ⁷		

Methyl alcohol is miscible with water, alcohol, or ether.

Use.—Methyl alcohol is used in our industries mainly as a solvent for extraction purposes.

¹ *Gazz. chim. ital.* **70** (1940), 710. *Chem. Abstracts* **35** (1941), 5091.

² *J. Chem. Soc.* (1933), 216.

³ *J. Am. Chem. Soc.* **54** (1932), 3760.

⁴ *Ibid.* **64** (1942), 179.

⁵ *Ibid.* **61** (1939), 2909.

⁶ *J. Am. Pharm. Assocn.* **30** (1941), 49.

⁷ Vol. III, 27, 45; Vol. VII, 34–79. (N. Y., McGraw-Hill Co., 1928–29).

⁸ *Gazz. chim. ital.* **70** (1940), 710. *Chem. Abstracts* **35** (1941), 5091.

⁹ *J. Res. Natl. Bur. Stds.* **17** (1936), 724.

SUGGESTED ADDITIONAL LITERATURE

L. Zepalova-Mikhaïlova, "Ebulliometric Investigation of Pure Liquids," *Trans. Inst. Pure Chem. Reagents U.S.S.R.* No. 16 (1939), 51. *Chem. Abstracts* **34** (1940), 3960.

G. J. W. Ferrey, "Tests for Acetone and Ethyl Alcohol, with Special Reference to Methyl Alcohol," *Quart. J. Pharm. Pharmacol.* **18** (1945), 193. *Chem. Abstracts* **40** (1946), 1279.

Ethyl Alcohol

C_2H_6O

Mol. Weight 46.07

Ethanol

$CH_3 \cdot CH_2 \cdot OH$

Occurrence.—Ethyl alcohol is a normal genetic constituent of volatile oils in only a few cases; it is, however, frequently encountered as an adulterant. The analysis of an oil should, therefore, always include a test for the presence

of ethyl alcohol. Moreover, ethanol occurs in the distillation waters of many oils, therefore, also in the oils of cohobation as the result of biological activity upon the plant material. Several essential oils—styrax oil, for example—contain ethyl alcohol in ester form.

Isolation.—By fractional distillation, and preparation of the calcium chloride complex.

On slow distillation with hydrogen iodide (d 1.7), ethyl alcohol forms ethyl iodide $b.$ 72° which, according to Gettler et al.,¹ may be used for the isolation and identification of ethyl alcohol in extreme dilution (0.0025%).

Identification.—Ethyl alcohol can be characterized by the preparation of several derivatives:

- (1) *p*-Nitrobenzoate $m.$ 57° (crystallized from alcohol), according to Henstock.²
- (2) 3,5-Dinitrobenzoate $m.$ 92° (crystallized from alcohol or petroleum ether), according to Orchin.³
- (3) Acid phthalate $m.$ 47° – 48° (difficult to crystallize), according to Goggans and Copenhaver.⁴
- (4) Ethoxy derivative from pseudosaccharin chloride. Pseudosaccharin chloride is prepared in 80% yield from saccharin and phosphorus pentachloride heated at 175° for 1.5 hr. The alcohol reacts readily with the chloride to yield the ethoxy derivative after 10 min. of heating, $m.$ 219° , according to Meadoc and Reid.⁵
- (5) 2,4-Dinitrophenylcarbamate $m.$ 110° , according to van Ginkel.⁶

Properties.—Zepalova-Mikaïlova,⁷ Wojciechowski,⁸ and International Critical Tables⁹ recorded these properties for 100 per cent ethanol:

$b.$	78.325° ⁸
d_4^{15}	0.79357 ⁷
n_D^{20}	1.3610 ⁹ (99.9%)

Ethyl alcohol is miscible with water, ether, petroleum ether, glycerol, etc. With water it forms a binary, constant boiling mixture $b.$ 78.5° containing 95.57 per cent ethyl alcohol by weight.

When heated with iodine, potassium iodide solution, and dilute sodium hydroxide solution, ethyl alcohol yields iodoform $m.$ 119° .

Use.—Ethyl alcohol is most widely used in our industries as a solvent for perfume and flavor compounds, and for extraction purposes. However, special methods of purification may be required on many commercial stocks when intended for these purposes.

¹ *J. Am. Chem. Soc.* **54** (1932), 1476.

² *J. Chem. Soc.* (1933), 216.

³ *J. Assocn. Official Agr. Chem.* **25** (1942), 839.

⁴ *J. Am. Chem. Soc.* **61** (1939), 2909.

⁵ *Ibid.* **65** (1943), 457.

⁶ *Rec. trav. chim.* **61** (1942), 149. *Chem. Abstracts* **37** (1943), 6252.

⁷ *Trans. Inst. Pure Chem. Reagents U.S.S.R.*, No. 16 (1939), 51. *Chem. Abstracts* **34** (1940) 3960.

⁸ *J. Res. Natl. Bur. Stds.* **17** (1936), 724.

⁹ Vol. VII (1930), 12.

SUGGESTED ADDITIONAL LITERATURE

G. J. W. Ferrey, "Tests for Acetone and Ethyl Alcohol, with Special Reference to Methyl Alcohol," *Quart. J. Pharm. Pharmacol.* **18** (1945), 193. *Chem. Abstracts* **40** (1946), 1279.

n-Butyl AlcoholC₄H₁₀O

Mol. Weight 74.12

n-Butanol

Occurrence.—*n*-Butyl alcohol occurs as ester in Roman chamomile oil.

Isolation.—By fractional distillation and through the acid phthalate.

Identification.—By the preparation of derivatives:

(1) *p*-Nitrobenzoate m. 35.3°, according to Armstrong and Copenhaver.¹ This derivative permits identifying *n*-butyl alcohol even in 0.25% aqueous solutions, according to Henstock.²

(2) Acid phthalate m. 73.1°–73.5° (corr.), according to Goggans and Copenhaver.³

(3) 2,4-Dinitrophenylcarbamate m. 94° (from petroleum ether), according to van Ginkel.⁴

(4) *S*-Benzylthiuronium *n*-butyl sulfate: Add 5 drops of the *n*-butyl alcohol to a mixture of 4 drops of chlorosulfonic acid and 5 drops of dioxane, and warm the mixture with shaking. Add 1 cc. of water and 1 cc. of a saturated aqueous solution or a 15% alcoholic solution of *S*-benzyl thiuronium chloride. Cool the mixture. M. 100°–101°, according to Bair and Suter.⁵

Properties.—Timmermans and Martin,⁶ Wojciechowski,⁷ Huston and Agett,⁸ and Longtin, Randall and Weber⁹ reported these properties:

b.	117.726° ⁷	n _D ²³	1.3993 ⁸
d ₄ ²⁴	0.8070 ⁸	n _D ²⁰	1.39949 ⁹
d ₄ ²⁰	0.8096 ⁶	n _D ¹⁵	1.40118 ⁶

n-Butyl alcohol is soluble in about 11 volumes of water at 15°. From aqueous solutions the alcohol can be salted out with calcium chloride or potassium carbonate. With water, *n*-butyl alcohol forms a constant boiling mixture b. 92.25° containing 63 per cent by weight of *n*-butyl alcohol.

On oxidation with chromic acid–sulfuric acid, *n*-butyl alcohol yields *n*-butyraldehyde and *n*-butyric acid.

Use.—*n*-Butyl alcohol is used in our industries for the preparation of esters which have attained considerable importance in the flavor industry.

¹ *J. Am. Chem. Soc.* **65** (1943), 2252.

² *J. Chem. Soc.* (1933), 216.

³ *J. Am. Chem. Soc.* **61** (1939), 2909.

⁴ *Rec. trav. chim.* **61** (1942), 149. *Chem. Abstracts* **37** (1943), 6252.

⁵ *J. Am. Chem. Soc.* **64** (1942), 1978.

⁶ *J. chim. phys.* **25** (1928), 427.

⁷ *J. Res. Natl. Bur. Stds.*, **17** (1936), 724.

⁸ *J. Org. Chem.* **6** (1941), 128.

⁹ *J. Phys. Chem.* **45** (1941), 340.

SUGGESTED ADDITIONAL LITERATURE

William N. Lipscomb and Robert H. Baker, "Identification of Alcohols in Aqueous Solution," *J. Am. Chem. Soc.* **64** (1942), 179.

Isobutyl Alcohol

C₄H₁₀O

Mol. Weight 74.12

Isopropylcarbinol. 2-Methylpropanol

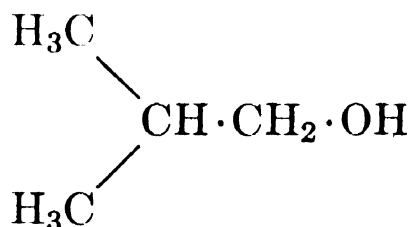

Occurrence.—Isobutyl alcohol has been identified in the distillation waters of *Eucalyptus amygdalina*. Bohnsack¹ recently reported it in raspberry oil.

Isolation.—By fractional distillation and through the acid phthalate.

Identification.—By the preparation of derivatives:

(1) *p*-Nitrobenzoate m. 69.5°, according to Armstrong and Copenhaver.² Through this derivative isobutyl alcohol can be identified even in 0.25% aqueous solution.

(2) 3,5-Dinitrobenzoate m. 87°, according to Bryant.³ Lipscomb and Baker⁴ recommend this derivative for the identification of isobutyl alcohol in aqueous solution without the necessity of isolating the alcohol *per se*.

(3) *S*-Benzylthiuronium isobutyl sulfate: The alcohol is converted to the corresponding acid sulfate, which in turn is reacted with *S*-benzylthiuronium chloride. Derivative m. 136°–137°, according to Bair and Suter.⁵

(4) 2,4-Dinitrophenylcarbamate m. 100°, according to van Ginkel.⁶

Properties.—Timmermans and Martin,⁷ and Brunel, Crenshaw and Tobin⁸ reported these properties:

b.	108.1° ⁷	n _D ²⁵	1.3939 ⁸
d ₄ ²⁵	0.79801 ⁸	n _D ¹⁵	1.39768 ⁷
d ₄ ²⁰	0.80196 ⁷		

Isobutyl alcohol is soluble in 10 parts of water at 15°. With water it forms a constant boiling mixture b. 89.2° containing 66.8 per cent by weight of isobutyl alcohol and 33.2 per cent of water.

On oxidation with dilute alkaline potassium permanganate in the cold, isobutyl alcohol yields isobutyric acid.

Use.—Isobutyl alcohol is used in our industries for the preparation of esters which have attained considerable importance in the flavor industry.

¹ *Ber.* **75B** (1942), 72.

⁴ *Ibid.* **64** (1942), 179.

² *J. Am. Chem. Soc.* **65** (1943), 2252.

⁵ *Ibid.* 1978.

³ *Ibid.* **54** (1932), 3760.

⁶ *Rec. trav. chim.* **61** (1942), 149. *Chem. Abstracts* **37** (1943), 6252.

⁷ *J. chim. phys.* **25** (1928), 429.

⁸ *J. Am. Chem. Soc.* **43** (1921), 575.

SUGGESTED ADDITIONAL LITERATURE

L. Zepalova-Mikhailova, "Ebulliometric Investigation of Pure Liquids," *Trans. Inst. Pure Chem. Reagents U.S.S.R.*, No. 16 (1939), 51. *Khim. Referat. Zhur.*, No. 6 (1939), 70. *Chem. Abstracts* **34** (1940), 3960.

n-Amyl Alcohol

C₅H₁₂O

Mol. Weight 88.15

1-Pentanol

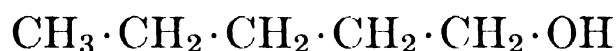

Occurrence.—Amyl alcohol has been identified in the ethereal oil derived from apples, and in cotton herb oil.

Isolation.—By fractional distillation and through the acid phthalate or the *p*-hydroxybenzoate.

Identification.—By the preparation of derivatives:

(1) Acid phthalate m. 75.4°–75.6° (corr.), according to Goggans and Copenhaver.¹

(2) S-Benzylthiuronium *n*-amyl sulfate: The alcohol is converted to the corresponding acid sulfate, which in turn is reacted with S-benzylthiuronium chloride. Derivative m. 85°–86°, according to Bair and Suter.²

(3) 2,4-Dinitrophenylcarbamate m. 84°, according to van Ginkel³ who prepared this derivative from the 1-(2,4-dinitrophenyl)-3-methyl-3-nitrourea.

Properties.—Wojciechowski,⁴ and Timmermans and Hennaut-Roland⁵ reported these properties:

m.	−73.85° ⁵	d ₄ ³⁰	0.80764 ⁵
b.	138.06° ⁴	d ₄ ¹⁵	0.81837 ⁵
		n _D ¹⁵	1.41173 ⁵

n-Amyl alcohol is soluble in 5 volumes of water at 30°. With water it forms a constant boiling mixture b. 95.8° which contains 45.6 per cent of *n*-amyl alcohol and 54.4 per cent of water.

Oxidation of *n*-amyl alcohol with chromic acid–sulfuric acid yields *n*-valeraldehyde, and finally *n*-valeric acid.

Use.—Amyl alcohol is used in our industries as a solvent and for the preparation of esters which have attained considerable importance in the flavor industry.

¹ *J. Am. Chem. Soc.* **61** (1939), 2909.

² *Ibid.* **64** (1942), 1978.

³ *Rec. trav. chim.* **61** (1942), 149. *Chem. Abstracts* **37** (1943), 6252.

⁴ *J. Research Natl. Bur. Stds.* **17** (1936), 724.

⁵ *J. chim. phys.* **29** (1932), 539.

SUGGESTED ADDITIONAL LITERATURE

"Standard Specifications for Amyl Alcohol (Synthetic)," Amer. Soc. Testing Materials, Standards, 1940, Supplement Part II, Non-Metallic (Constr.), 158.

Isoamyl Alcohol

$C_5H_{12}O$ Mol. Weight 88.15

3-Methylbutanol

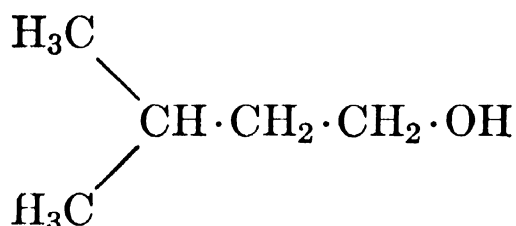

Occurrence.—Isoamyl alcohol occurs free in oil of Java citronella, Réunion geranium, lavender, French peppermint, *Eucalyptus globulus*, and *E. amygdalina*. As ester isoamyl alcohol occurs in oil of cognac, Roman chamomile, *Eucalyptus globulus*, raspberry, and a few other essential oils.

Isolation.—The differential between the rates of chlorination offers a means of separating isoamyl alcohol from optically active amyl alcohols. According to Birun,¹ the rate of formation is slower for the active alcohols.

Identification.—By the preparation of derivatives:

- (1) 3,5-Dinitrobenzoate m. 61°–62°, according to Reichstein.²
- (2) Acid 3-nitrophthalate m. 165°–166° (crystallized from water), according to Nicolet and Sachs.³
- (3) α -Naphthylurethane m. 67°, according to Huston and Agett.⁴
- (4) Isoamyloxy derivative from pseudosaccharin chloride m. 64°, according to Meadoc and Reid.⁵

Properties.—The following properties have been reported by Timmermans and Hennaut-Roland:⁶

b.	132°
d_4^{20}	0.80918
n_D^{15}	1.40851

Isoamyl alcohol is a cough provoking liquid of somewhat disagreeable odor. Water dissolves at room temperature 3.3 volumes of isoamyl alcohol. Isoamyl alcohol forms with water a constant boiling mixture b. 95.15° containing 50.04 per cent by weight of isoamyl alcohol and 49.60 per cent of water.

Use.—Isoamyl alcohol is used for the preparation of esters which have attained considerable importance in the flavor industry.

¹ *Nauch. Zapiski Inst. Narodnogo Khoz. im. Plekhanova* (1938), No. 1, 120. *Chem. Abstracts* **34** (1940), 1969.

² *Helv. Chim. Acta* **9** (1926), 802.

³ *J. Am. Chem. Soc.* **47** (1925), 2349.

⁴ *J. Org. Chem.* **6** (1941), 128.

⁵ *J. Am. Chem. Soc.* **65** (1943), 457.

⁶ *Anales soc. españ. fis. quim.* **27** (1929), 460 (in French). *Chem. Abstracts* **24** (1930), 54.

n-Hexyl AlcoholC₆H₁₄O

Mol. Weight 102.17

1-Hexanol



Occurrence.—*n*-Hexyl alcohol has been identified in oil of *Heracleum giganteum* and a few other essential oils where it occurs as ester.

Isolation.—By fractional distillation and through the *p*-hydroxybenzoate, according to Olivier.¹

Identification.—By the preparation of derivatives:

- (1) 3,5-Dinitrobenzoate m. 60°–61°, according to Sutter.²
- (2) S-Benzylthiuronium *n*-hexyl sulfate: The alcohol is converted to the corresponding acid sulfate, which in turn is reacted with S-benzylthiuronium chloride. Derivative m. 85°–86°, according to Bair and Suter.³
- (3) α -Naphthylurethane m. 60°–61°, according to Bohnsack.⁴
- (4) 2,4-Dinitrophenylcarbamate m. 82°, according to van Ginkel.⁵

Properties.—The following properties have been recorded by Hovorka, Lankelma and Stanford:⁶

b.	157.04 ± 0.2°	n _D ²⁵	1.4158
d ₄ ²⁰	0.8193 (Olivier)	n _D ¹⁵	1.4198

n-Hexyl alcohol is slightly soluble in water at 25° (0.624 per cent by weight).

On oxidation with potassium bichromate and sulfuric acid, *n*-hexyl alcohol yields *n*-caproic acid.

Use.—*n*-Hexyl alcohol is used in our industry for the preparation of a few esters.

¹ *Rec. trav. chim.* **55** (1936), 1034.

² *Helv. Chim. Acta* **21** (1938), 1267.

³ *J. Am. Chem. Soc.* **64** (1942), 1978.

⁴ *Ber.* **74B** (1941), 1575.

⁵ *Rec. trav. chim.* **61** (1942), 149. *Chem. Abstracts* **37** (1943), 6252.

⁶ *J. Am. Chem. Soc.* **60** (1938), 823.

3-Methyl-1-pentanol

C₆H₁₄O

Mol. Weight 102.17

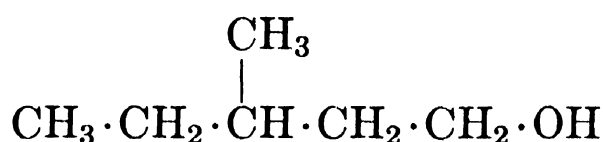
 β,β -Methylethylpropyl Alcohol

Occurrence.—Esterified with angelic acid, this optically active hexyl alcohol occurs in Roman chamomile oil, according to van Romburgh¹ and Blaise.² Bohnsack³ reported the dextro isomer in Réunion geranium oil, the laevo isomer in the foreruns of Java citronella oil.

Isolation.—By fractional distillation, and by means of the acid phthalate (cf. Levene and Marker,⁴ and Bohnsack⁵).

Identification.—Oxidation of the naturally occurring alcohols with chromic acid mixture yielded optically active caproic acid b. 196°–198°, amide m. 123.5°–124°, according to van Romburgh⁶ and Bohnsack.⁷ Bohnsack⁸ obtained the pure laevo- α -naphthylurethane m. 97°–98°.

Properties.—The natural optically active hexyl alcohol isolated from Roman chamomile oil has these properties:

b.	154°
d ₁₅	0.829
[α] _D ²⁰	+8° 12'

The purified isolate from Réunion geranium oil was reported by Bohnsack⁹ as follows:

b.	154°	d ₁₅ ¹⁸	0.826
b ₉	52°–54°	[α] _D ²⁰	+2° 24'

Employing the combined borate and phthalate method, Bohnsack¹⁰ isolated a laevorotatory 3-methyl-1-pentanol from Java citronella oil:

b.	154°–156°	d ₁₅ ²¹	0.8270
b ₁₀	52°–54°	[α] _D ¹⁵	approx. –2°

Synthetic *d*-3-methyl-1-pentanol has been prepared by Levene and Marker¹¹ and purified by means of the acid phthalate. It had these characteristics:

b ₂₅	72°	[α] _D ²⁷	+3° 37'
d ₄ ²⁷	0.822	n _D ²⁵	1.4182

Synthetic *l*-3-methyl-1-pentanol has been prepared by Veibel et al.¹² Levene and Rothen¹³ reported its specific optical rotation as [α]_D²⁵ –3° 12'.

Regarding properties and identification of synthetic 3-methyl-1-pentanol in general, see Hovorka, Lankelma and Schneider,¹⁴ Bohnsack,¹⁵ and Sutter.¹⁶

Use.—Nothing is known in literature about the use of 3-methyl-1-pentanol.

¹ *Rec. trav. chim.* **5** (1886), 219; **6** (1887), 150.

² *Bull. soc. chim.* III, **29** (1903), 327.

³ *Ber.* **74B** (1941), 1575; **75B** (1942), 502; **76B** (1943), 564.

⁴ *J. Biol. Chem.* **91** (1931), 77.

⁵ *Ber.* **74B** (1941), 1575; **75B** (1942), 502.

⁶ *Rec. trav. chim.* **6** (1887), 150.

⁷ *Ber.* **74B** (1941), 1575.

⁸ *Ber.* **76B** (1943), 564.

⁹ *Ber.* **74B** (1941), 1575; **75B** (1942), 502.

¹⁰ *Ber.* **76B** (1943), 564.

¹¹ *J. Biol. Chem.* **91** (1931), 85.

¹² *Biochem. Z.* **252** (1932), 401. *Bull. soc. chim.* [5], **6** (1939), 990.

¹³ *J. Biol. Chem.* **115** (1936), 426.

¹⁴ *J. Am. Chem. Soc.* **62** (1940), 1096.

¹⁵ *Ber.* **74** (1941), 1575; **76** (1943), 564.

¹⁶ *Helv. Chim. Acta* **21** (1938), 1266.

2-Heptanol

C₇H₁₆O

Mol. Weight 116.20

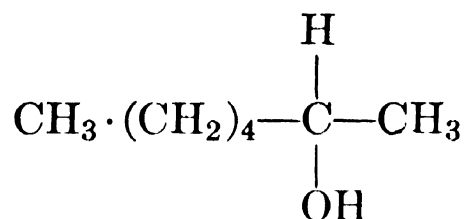
n-Amylmethylcarbinol. sec.-Heptyl Alcohol

Occurrence.—This heptyl alcohol was identified by Masson ¹ in clove oil.

Isolation.—By fractional distillation and through the acid phthalate (see below).

Identification.—The naturally occurring *n*-amylnmethylcarbinol was characterized as follows:

(1) Oxidation with chromic acid mixture yielded methyl-*n*-amylketone; the latter identified by the preparation of its semicarbazone m. 122°–123°.

(2) By the preparation of the pyruvic ester, the semicarbazone of which melted at 118°–119°.

The acid phthalate of *dl*-2-heptanol melts at 57°–58°, according to Pickard and Kenyon,² that of the *d*- or *l*- form melts at 76.5°, the brucine salt thereof at 137°–138°, and the strychnine salt at 203°–204°.

Properties.—Masson ³ reported for 2-heptanol, isolated from clove oil:

b. 157°–158°
d₀ 0.8344

The synthetic products of Pickard and Kenyon ⁴ had these properties:

	<i>d</i>		<i>l</i>
b ₂₀	73.5°	b ₂₃	74.5°
d ₄ ²⁰	0.8185	d ₄ ²⁰	0.8184
[α] _D ²⁵	+10° 13'	[α] _D ¹⁷	–10° 29'
n _D ²⁰	1.4209		

Regarding derivatives and properties of *dl*-2-heptanol, see Huntress and Mulliken,⁵ and Heilbron.⁶

Use.—2-Heptanol is not used in our industries.

¹ *Compt. rend.* **149** (1909), 630.

² *J. Chem. Soc.* **99** (1911), 60, 61, 63, 65.

³ *Compt. rend.* **149** (1909), 630.

⁴ *J. Chem. Soc.* **99** (1911), 60, 61, 63, 65.

⁵ "Identification of Pure Organic Compounds," Order I (1941), 447.

⁶ "Dictionary of Organic Compounds," Vol. II (1943).

***n*-Octyl Alcohol**C₈H₁₈O

Mol. Weight 130.22

1-Octanol

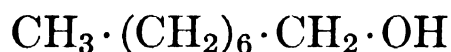

Occurrence.—This alcohol occurs free and as acetate in oil of *Heracleum giganteum*. Takei, Sakato and Ono¹ in 1936 observed the alcohol in oil of green tea. In ester form, *n*-octyl alcohol is present also in a few other essential oils.

Isolation.—Mikhaïlova, Nikolaeva and Bel'skaya² recommend oxidation of *Heracleum* oil with 10% potassium permanganate and subsequent hydrolysis with 25% potassium hydroxide. The hydrolyzate is steam-distilled, and the nonaqueous layer dried and fractionally distilled to give a 60% yield of pure octanol.

Generally this alcohol may be obtained by fractional distillation and through the *p*-hydroxybenzoate, according to Olivier.³

Identification.—(1) By the preparation of derivatives:

- (a) 3,5-Dinitrobenzoate m. 60.8°, according to Malone and Reid.⁴
- (b) α -Naphthylurethane m. 66°, according to Huston and Agett.⁵
- (c) Phenylurethane m. 74°, according to Dewey and Witt.⁶
- (d) 2,4-Dinitrophenylcarbamate m. 76°, according to van Ginkel,⁷ from the 1-(2,4-dinitrophenyl)-3-methyl-3-nitrourea.
- (e) Takei, Sakato and Ono⁸ reported the urethane as m. 147°.

(2) Oxidation of *n*-octyl alcohol yields *n*-octyl aldehyde, the β -naphthocinchonic acid compound m. 234°.

Properties.—These properties of *n*-octyl alcohol have been reported by Dorough, Glass, Gresham, Malone and Reid:⁹

m.	−15.0°	d ₄ ²⁵	0.8224
b.	195°	d ₄ ⁰	0.8394
b ₃₀₀	164°	n _D ²⁵	1.4275
b ₁₀₀	135°	M _D	40.68
b ₂₀	100.7°		

n-Octyl alcohol is only sparingly soluble in water at 25° (0.0586 per cent by weight).

Use.—Synthetic octyl alcohol is used as a modifier in the compounding of synthetic flower oils—for example, rose and lilac. It serves well in orris root compositions and in many perfumes of fancy character.

¹ *Bull. Inst. Phys. Chem. Research Tokyo* **15** (1936), 626; **16** (1937), 7. *Chem. Abstracts* **31** (1937), 6814.

² *Org. Chim. Ind. U.S.S.R.* **6** (1939), 594. *Chem. Abstracts* **34** (1940), 5047.

³ *Rec. trav. chim.* **56** (1937), 256.

⁴ *J. Am. Chem. Soc.* **51** (1929), 3426.

⁵ *J. Org. Chem.* **6** (1941), 128.

⁶ *Ind. Eng. Chem., Anal. Ed.* **12** (1940), 459.

⁷ *Rec. trav. chim.* **61** (1942), 149. *Chem. Abstracts* **37** (1943), 6252.

⁸ *Bull. Inst. Phys. Chem. Research Tokyo* **16** (1937), 7. *Chem. Abstracts* **31** (1937), 6815.

⁹ *J. Am. Chem. Soc.* **63** (1941), 3102.

3-Octanol

C₈H₁₈O

Mol. Weight 130.22

Ethyl-*n*-amylcarbinol

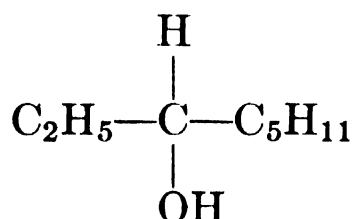

Occurrence.—This secondary octyl alcohol has been found in Japanese mint oil (*Mentha arvensis*) by Schimmel & Co.,¹ likewise by Naves,² free and as acetate in European pennyroyal oil.

Isolation.—By fractional distillation, and through the acid phthalate.

Identification.—The urethane of *l*-3-octanol is reported by Levene and Walti³ as melting at 79°–80°, and that of *d*-3-octanol by Gildemeister and Hoffmann⁴ as melting at 81°–82°. (Also see section on “Properties.”)

Properties.—According to Schimmel & Co.,⁵ the natural alcohol from Japanese mint oil, purified through its acid phthalate, has these properties:

b.	178.5°–179.5°	α_D	+6° 17'
b _{3.5}	56°	n _D ²⁰	1.42775
d ₁₅ ¹⁵	0.8279		

The *d*-3-octanol isolated from oil of *Mentha pulegium* L. by Naves⁶ is described as follows:

b ₇₃₂	176°–176.5°	$[\alpha]_D^{20}$	+7° 56' (homogeneous)
b _{2.2}	52°–53°		+9° 16' (c = 20, alcohol)
d ₄ ²⁰	0.8246	n _D ²⁰	1.42682
		RM _D	obs. 40.52
			calc. 40.67

A synthetic laevorotatory 3-octanol is described by Levene and Walti⁷ as follows:

b ₂₄	82°		
α_D^{25}	–4° 39' (homogeneous)		
$[\alpha]_D^{27}$	–7° 24' (abs. alc.)		

Optically inactive ethyl-*n*-amylcarbinol was prepared by Schimmel & Co.,⁸ and by Pickard and Kenyon.⁹ Its acid phthalate melted at 65°–65.5°. A

patented catalytic procedure by I. G. Farbenindustrie¹⁰ yields a product b. 180°–181°. Murahashi¹¹ reported the *p*-iododiphenylurethane of dihydromatsutake alcohol, identical with 3-octanol as m. 158.5°–159.3°. Unless racemization occurs, this derivative has approximately the same melting point for all forms of the alcohol.

A recent careful study of racemic 3-octanol by Dorough, Glass, Gresham, Malone and Reid¹² yielded these properties:

m.	–45°	d_4^{25}	0.8169
b.	173°	d_4^0	0.8361
b_{300}	140.5°	n_D^{25}	1.4209
b_{100}	110.2°	M_D	40.41
b_{20}	75.9°	Sol.	1.252 g. of octanol are soluble in 1 kg. of water

Use.—This alcohol is not used in our industries.

¹ *Ber. Schimmel & Co.*, April (1912), 101.

² *Helv. Chim. Acta* **26** (1943), 1034.

³ *J. Biol. Chem.* **94** (1931), 596.

⁴ "Die Ätherischen Öle," 3d Ed., Vol. III, 838.

⁵ *Ber. Schimmel & Co.*, April (1912), 101.

⁶ *Helv. Chim. Acta* **26** (1943), 1034.

⁷ *J. Biol. Chem.* **94** (1931), 593.

⁸ *Ber. Schimmel & Co.*, April (1913), 79.

⁹ *J. Chem. Soc.* **103** (1913), 1945.

¹⁰ French Patent 656, 178, June 21, 1928.

¹¹ *Sci. Papers Inst. Phys. Chem. Research Tokyo* **30** (1936), 263; **34** (1938), 155. *Chem. Abstracts* **32** (1938), 3755.

¹² *J. Am. Chem. Soc.* **63** (1941), 3102.

n-Nonyl Alcohol

$C_9H_{20}O$

Mol. Weight 144.25

1-Nonanol

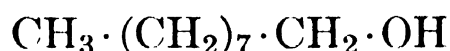

Occurrence.—As caprylate in sweet orange oil.

Isolation.—By fractional distillation and through the acid phthalate, or *p*-hydroxybenzoate.

Identification.—*n*-Nonyl alcohol can be characterized by the preparation of several derivatives:

(1) 3,5-Dinitrobenzoate m. 52.0°, according to Späth, Pailer and Schmid.¹

(2) Acid phthalate m. 42.4°–42.6° (corr.), according to Goggans and Copenhaver.²

(3) Phenylurethane m. 60°, according to Dewey and Witt.³

(4) 2,4-Dinitrophenylcarbamate m. 72°, according to van Ginkel.⁴

Properties.—*n*-Nonyl alcohol possesses an odor slightly reminiscent of rose. Stephan ⁵ purified the alcohol through the acid phthalate, Olivier ⁶ through the *p*-hydroxybenzoate m. 40.5°–41.3°. The following properties have been reported by these authors, by Ellis and Reid,⁷ and by Nametkin and Shagalova:⁸

b.	213°–213.5° ^{6,7}	α_D	$\pm 0^\circ$ ⁵
b ₁₂	98°–101° ⁵	n _D ²⁰	1.435 ⁸
d ₄ ²⁵	0.82303 ⁷	n _D ¹⁵	1.43582 ⁵
d ₄ ²⁰	0.8271 ^{6,8}		

On oxidation *n*-nonyl alcohol yields nonyl aldehyde and nonylic (pelargonic) acid m. 12.5°.

Use.—Small quantities of *n*-nonyl alcohol are used in rose compositions and in artificial orange oils.

¹ *Ber.* **74B** (1941), 1555. Cf. Malone and Reid, *J. Am. Chem. Soc.* **51** (1929), 3426.

² *J. Am. Chem. Soc.* **61** (1939), 2909.

³ *Ind. Eng. Chem. Anal. Ed.* **12** (1940), 459. Cf. Stephan, *J. prakt. Chem.* II, **62** (1900), 532.

⁴ *Rec. trav. chim.* **61** (1942), 149. *Chem. Abstracts* **37** (1943), 6252.

⁵ *J. prakt. Chem.* II, **62** (1900), 532.

⁶ *Rec. trav. chim.* **56** (1937), 256.

⁷ *J. Am. Chem. Soc.* **54** (1932), 1678.

⁸ *Sintezy Dushistykh Veshchestv, Sbornik Stateĭ* (1939), 274. *Khim. Referat. Zhur.*, No. 4 (1940), 118. *Chem. Abstracts* **36** (1942), 3781.

2-Nonanol

C₉H₂₀O

Mol. Weight 144.25

Methyl-*n*-heptylcarbinol

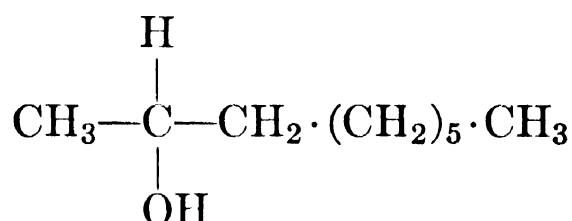

Occurrence.—A secondary laevorotatory nonyl alcohol was found by Mason ¹ in oil of clove, and by Power and Lees ² in Algerian rue oil. The optical antipode of this alcohol occurs in the volatile coconut oil, according to Haller and Lassieur.³

Isolation.—By fractional distillation, and through the phthalic esters.

Identification.—The laevorotatory methyl-*n*-heptylcarbinol can be characterized:

(1) By oxidation to methyl-*n*-heptyl ketone which may be identified by the preparation of its semicarbazone m. 118°–119°.

(2) With pyruvic acid this alcohol forms an ester b₁₆ 126°–127°, the semicarbazone of which melts at 117°.

The dextrorotatory alcohol, on treatment with phthalic anhydride, yields an acid ester, according to Pickard and Kenyon,⁴ m. 58°–59°, $[\alpha]_D +46^\circ 4'$ (in ethyl alcohol), the inactive form melting at 42°–44°. The brucine salt of the *d*-acid phthalate melts at 140°–142°, the strychnine salt at 142°–143°.

Properties.—Power and Lees⁵ recorded these properties for laevorotatory methyl-*n*-heptylcarbinol:

b_{765}	198°–200°
d_{16}^{19}	0.8273
α_D (50 mm. tube)	–3° 44'

Masson⁶ reported for the alcohol isolated from clove oil:

b.	195°–196°
d_0	0.8399

The dextrorotatory modification of this secondary nonyl alcohol as derived from volatile coconut oil was described by Haller and Lassieur:⁷

d_4^{25}	0.823
α_D	+2° 0'
n_D^{21}	1.4249

d-Methyl-*n*-heptylcarbinol, prepared synthetically by Pickard and Kenyon,⁸ had these properties:

b_{19}	105°	$[\alpha]_D^{19}$	+8° 59'
d_4^{25}	0.8202	n_D^{20}	1.4299
d_4^{20}	0.8230		
$d_4^{13.1}$	0.8281		

Regarding *dl*-2-nonanol, its properties and derivatives, see Huntress and Mulliken,⁹ and Heilbron.¹⁰

Use.—2-Nonanol is used very little, if at all, in our industries.

¹ *Compt. rend.* **149** (1909), 630.

² *J. Chem. Soc.* **81** (1902), 1592.

³ *Compt. rend.* **151** (1910), 697.

⁴ *J. Chem. Soc.* **99** (1911), 60, 61, 63.

⁵ *Ibid.* **81** (1902), 1592.

⁶ *Compt. rend.* **149** (1909), 630.

⁷ *Ibid.* **151** (1910), 697.

⁸ *J. Chem. Soc.* **99** (1911), 55, 70.

⁹ "Identification of Pure Organic Compounds," Order I (1941), 452.

¹⁰ "Dictionary of Organic Compounds," Vol. II (1943), 724.

1-Decanol

 $C_{10}H_{22}O$

Mol. Weight 158.28

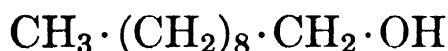
n-Decyl Alcohol

Occurrence.—Decyl alcohol occurs in oil of ambrette seed.

Isolation.—By fractional distillation and through the acid phthalate.

Identification.—By the preparation of derivatives:

- (1) Acid phthalate m. 37.9° , according to Goggans and Copenhaver.¹
- (2) Acid *m*-nitrophthalate m. 122.7° – 122.8° (corr.), according to Dickinson, Crosson and Copenhaver.²
- (3) S-Benzylthiuronium *n*-decyl sulfate: The alcohol is converted to the corresponding acid sulfate, which in turn is reacted with S-benzylthiuronium chloride. Derivative m. 73° – 75° , according to Bair and Suter.³
- (4) Dinitrophenylcarbamate m. 70° , according to van Ginkel.⁴

Properties.—Hoerr, Harwood and Ralston,⁵ and Kao and Ma⁶ recorded these properties:

f.p.	6.88° ⁵	d_4^{20}	0.8292 ⁶
b.	231° ⁶	n_D^{20}	1.43682 ⁶

n-Decyl alcohol is a somewhat viscid oil of characteristic odor, slightly reminiscent of orange.

On oxidation with potassium permanganate and dilute sulfuric acid, it yields *n*-capric acid.

Use.—*n*-Decyl alcohol is used quite widely but most sparingly as a modifier of citrus scents. As such, it serves in flavors as well as in perfumes.

¹ *J. Chem. Soc.* **61** (1939), 2909.

² *J. Am. Chem. Soc.* **59** (1937), 1095.

³ *Ibid.* **64** (1942), 1978.

⁴ *Rec. trav. chim.* **61** (1942), 149. *Chem. Abstracts* **37** (1943), 6252.

⁵ *J. Org. Chem.* **9** (1944), 267.

⁶ *Science Repts. Natl. Tsing Hua Univ. Ser. A*, **1** (1932), 181. *Chem. Zentr.* II (1932), 3076.

2-Hendecanol

 $C_{11}H_{24}O$

Mol. Weight 172.30

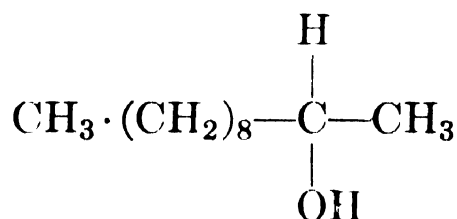
Methyl-*n*-nonylcarbinol. Undecan-2-ol

Occurrence.—Optically active secondary undecyl alcohols of this formula have been identified in Algerian rue oil by Power and Lees,¹ in trawas

leaf oil by van Romburgh,² and in the ethereal coconut oil by Haller and Lassieur.³

Isolation.—By fractional distillation and through the acid phthalate (see below).

Identification.—The acid phthalate of *dl*-undecan-2-ol melts at 49°–50°; the active form at 31°–32°, according to Pickard and Kenyon;⁴ brucine salt m. 113°–116°; strychnine salt m. 144°–145°.

On oxidation of the naturally occurring alcohol Power and Lees⁵ obtained methyl-*n*-nonyl ketone, the oxime of which melted at 46°–47°, the semicarbazone at 122°.

Properties.—The same authors reported these properties for the alcohol from oil of rue:

b.	231°–233°
α_D (25 mm. tube)	–1° 18'

Haller and Lassieur⁶ found for the undecan-2-ol isolated from ethereal coconut oil:

d_4^{23}	0.827
α_D	+1° 10'
n_D^{23}	1.4336

Pickard and Kenyon⁷ reported for the purified synthetic *d*-methyl-*n*-nonyl-carbinol these properties:

m.	12°	$[\alpha]_D^{18}$	+8° 11'
b_{20}	128°	n_D^{20}	1.4369
$d_4^{27.1}$	0.8226		
d_4^{20}	0.8270		
d_4^{14}	0.8318		

The synthetic *dl*- compound has been reported recently by Dreger, Keim, Miles, Shedlovsky and Ross,⁸ m. 0°, b_{27} 136°.

Use.—2-Hendecanol is not used in our industries.

¹ *J. Chem. Soc.* **81** (1902), 1592.

² *Kon. Akad. Wetensch. Amsterdam*, Meeting Oct. 28, 1911, 325.

³ *Compt. rend.* **151** (1910), 697.

⁴ *J. Chem. Soc.* **99** (1911), 60, 61, 63; **105** (1914), 850.

⁵ *Ibid.* **81** (1902), 1588, 1593.

⁶ *Compt. rend.* **151** (1910), 697.

⁷ *J. Chem. Soc.* **99** (1911), 55, 70; **105** (1914), 850.

⁸ *Ind. Eng. Chem.* **36**, No. 7 (1944), 612.

(b) UNSATURATED ALIPHATIC ALCOHOLS.

3-Hexen-1-ol

 $C_6H_{12}O$

Mol. Weight 100.16

 β, γ -Hexenol. "Leaf Alcohol"

The problem regarding the stereoisomerism of this unsaturated primary alcohol has been the subject of a polemic between Takei and collaborators¹ on the one hand, and Stoll and Rouvé² on the other. These latter workers claimed that the naturally occurring alcohol has the "cis-" form and that it is identical with the synthetic product prepared by them, whereas Takei et al. maintain that the natural product, which they isolated from green tea oil, represents the "trans-" isomer and that the synthetic "cis-" form is odorless. More recently Ruzicka, Schinz and Susz³ suggested that natural 3-hexen-1-ol obtained through saponification of the high boiling fraction from Japanese mint oil has the *cis*- form, while natural 3-hexen-1-ol isolated from ethereal violet leaf oil possesses the *trans*- configuration.

Occurrence.—According to van Romburgh,⁴ this alcohol forms the main constituent of the oil distilled from freshly *fermented* tea leaves, whereas Takei et al.⁵ recognized this hexenol in the fresh green tea only. Walbaum⁶ found that leaf alcohol occurs as phenylacetic ester in the last runs of Japanese mint oil (*Mentha arvensis*). Ruzicka and Schinz⁷ isolated 3-hexen-1-ol from ethereal violet leaf oil. Spanish thyme oil contains free 3-hexen-1-ol. Takei and collaborators⁸ reported that the volatile oil of *Thea chinensis* contains 25 to 35.3 per cent of 3-hexen-1-ol, oil of *Eurya japonica* 14 per cent, oil of *Parthenocissus thunbergii* Nakai 18.1 per cent, oil of *Fatsia japonica* Decne et Planch. 12.7 per cent, oil of *Trifolium repens* L. 22.2 per cent, oil of *Robinia pseudacacia* L. 50 per cent, oil of *Morus bombycis* Koidz. 50 per cent, and oil of *Raphanus sativus* L. 30 per cent. This alcohol* is probably present in many types of green leaves, herbs, and grasses, according to Franzen and co-authors⁹ who gathered organoleptic evidence from forty types. Bohnsack identified 3-hexen-1-ol in natural raspberry oil,¹⁰ in Java oil of citronella,¹¹ and in Réunion geranium oil.¹²

Isolation.—Leaf alcohol can be isolated from essential oils:

- (1) Through its acid phthalate.
- (2) On benzylation in pyridine solution, leaf alcohol forms a benzoate b_6 134°–136°, from which the alcohol can be regenerated by saponification.
- (3) Ruzicka, Schinz and Susz¹³ purified the natural 3-hexen-1-ol (from Japanese mint oil) through the allophanate m . 139°–140°.

* According to Gildemeister and Hoffmann ("Die Ätherischen Öle," 3rd ed., Vol. III, 840) the leaf alcohol described by Curtius and Franzen is α , β -hexenol, not β , γ - as found by Walbaum in Japanese mint oil.

Identification.—Leaf alcohol may be characterized by means of several derivatives. The worker, however, should take note of the variance in melting points as reported by different authorities, and recognize that these variations may as easily be attributed to the existence of *cis*- and *trans*- forms rather than impurities, such as isomerized hexenols.

DERIVATIVES, MELTING POINTS

Type	Synthetic Alcohol	Natural	Source	Authority
α -Naphthyl-urethane	I 61°–63° ¹⁶ II 41°–43° ¹⁷	71°–72° ¹⁴ 68° ¹⁵	Green tea oil	Gildemeister and Hoffmann ¹⁴ Takei et al. ¹⁵ Ruzicka, Schinz and Susz ¹⁶ Bohnsack ¹⁷
Allophanate	I { 146° ¹⁸ 143°–144° ¹⁶ 143° ¹⁵ II 133°–135° ¹⁶	146° ¹⁵ 139°–140° ¹⁶ 128.5°–129.5° ¹⁶	Green tea oil Japanese peppermint Violet leaf oil	Stoll and Rouvé ¹⁸
Acid phthalate Ag Salt	I II 118° ¹⁵	127° ¹⁴ 126° ¹⁵	Green tea oil	
3,5-Dinitrobenzoate	I { 49° ¹⁸ 45°–46° ²⁰ II 28° ¹⁹	49.5° ¹⁵ 49.0° ¹⁹ 48.0°–48.5° ²⁰	Green tea oil Green tea oil Japanese peppermint	Takei and collaborators ¹⁹ Stoll and Rouvé ²⁰
4'-Iododiphenyl-urethane	I 155°–156° ¹⁹ (Bouveault Method) II 148° ^{15,19} (Ruzicka Method)	157° ^{15,19}	Green tea oil	
Anthraquinone β -carboxylate	I 68° ¹⁸ II 50° ¹⁵	68° ¹⁵	Green tea oil	

Properties.—Walbaum²¹ reported these properties for leaf alcohol isolated from the last runs of Japanese mint oil, after saponification:

b.	156°–157°	d_{15}^{15}	0.8508
b_9	55°–56°	α_D	–0° 10'
		n_D^{20}	1.4803

Ruzicka, Schinz and Susz ²² purified and described as the *cis*- isomer a natural 3-hexen-1-ol (from Japanese mint oil) through its allophanate m. 139°–140° and found these properties:

b_{12}	58°–58.5°	n_D^{20}	1.4380
d_4^{20}	0.8495	M.R.	{ Obs. 30.92 Calc. 30.96

whereas Stoll and Rouvé ²³ reported the following properties of a synthetic product which they consider as *cis*-3-hexen-1-ol:

$b_{12.5}$	59°–61°
$d_4^{21.6}$	0.8478
n_D^{24}	1.4373

Ruzicka, Schinz and Susz ²⁴ prepared and purified the synthetic alcohol through its allophanate I, m. 143°–144° (see above), and on cleavage obtained synthetic 3-hexen-1-ol:

b_{12}	58.5°–60°
d_4^{20}	0.8480
n_D^{20}	1.4376

Properties of products from other sources appear to approximate these very closely (cf. Takei and co-workers, ²⁵ von Rechenberg, ²⁶ Curtius and Franzen, ²⁷ van Romburgh, ²⁸ Treff and Werner ²⁹ and Bohnsack ³⁰).

On dilution leaf alcohol has an odor characteristic of grass and fresh green leaves. The odor is strong, but not as pungent as that of leaf aldehyde.

Use.—Synthetic leaf alcohol is used in high quality perfume compositions where a note of grass and of green leaves is desired.

¹ *Ber.* **68B** (1935), 953. *J. Agr. Chem. Soc. Japan* **14** (1938), 709. *Ber.* **73B** (1940), 950.

² *Helv. Chim. Acta* **21** (1938), 1542. *Ber.* **73B** (1940), 1358.

³ *Ibid.* **27** (1944), 1561.

⁴ *Verslag Plantentuin te Buitenzorg* (1895), 119; (1896), 166. *Ber. Schimmel & Co.*, April (1897), 42; April (1898), 53. *Koninkl. Akad. Wetensch. Amsterdam, Wisk. en Natk. Afd.* **28** (1919), 83. *Chem. Zentr.* I (1920), 83.

⁵ *Bull. Inst. Phys. Chem. Research (Tokyo)* **14** (1935), 303; **16** (1937), 773. *Chem. Abstracts* **29** (1935), 8229; **32** (1938), 5155.

⁶ *J. prakt. Chem.* [2], **96** (1917), 245.

⁷ *Helv. Chim. Acta* **18** (1935), 381.

⁸ *J. Agr. Chem. Soc. Japan* **14** (1938), 709. *Chem. Abstracts* **33** (1939), 2558.

⁹ *Sitzb. Heidelberg Akad. Wiss. Math. Nat. Klass. Abt. A* (1920). Cf. *Ber. Schimmel & Co.* (1920), 137. *Z. physiol. Chem.* **112** (1920), 301. *Liebigs Ann.* **390** (1912), 109; **404** (1914), 129. *Chem. Zentr.* II (1912), 722.

¹⁰ *Ber.* **75B** (1942), 72.

¹¹ *Ber.* **76B** (1943), 564.

¹² *Ber.* **74B** (1941), 1575.

¹³ *Helv. Chim. Acta* **27** (1944), 1561. *Chem. Abstracts* **39** (1945), 3117.

¹⁴ "Die Ätherischen Öle," 3d Ed., Vol. III, 226.

¹⁵ *J. Agr. Chem. Soc. Japan* **14** (1938), 709. *Chem. Abstracts* **33** (1939), 2557.

- ¹⁶ *Helv. Chim. Acta* **27** (1944), 1561. *Chem. Abstracts* **39** (1945), 3117.
¹⁷ *Ber.* **74B** (1941), 1575.
¹⁸ *Ber.* **73B** (1940), 1358. See Takei et al., *Ber.* **73** (1940), 951.
¹⁹ *Ber.* **68B** (1935), 953.
²⁰ *Helv. Chim. Acta* **21** (1938), 1542.
²¹ *J. prakt. Chem.* II, **96** (1917), 245.
²² *Helv. Chim. Acta* **27** (1944), 1561. *Chem. Abstracts* **39** (1945), 3117.
²³ *Ibid.* **21** (1938), 1547.
²⁴ *Ibid.* **27** (1944), 1561. *Chem. Abstracts* **39** (1945), 3117. See Ruzicka and Schinz, *Helv. Chim. Acta* **17** (1934), 1602.
²⁵ *Ber.* **68B** (1935), 953. *Bull. Inst. Phys. Chem. Research (Tokyo)* **14** (1935), 303. *Chem. Abstracts* **29** (1935), 8229.
²⁶ *J. prakt. Chem.* [2], **101** (1921), 120.
²⁷ *Liebigs Ann.* **404** (1914), 128.
²⁸ *Koninkl. Akad. Wetensch. Amsterdam, Wisk. en Natk. Afd.* **28** (1919), 83. *Chem. Zentr.* I (1920), 83.
²⁹ *Ber.* **68B** (1935), 640.
³⁰ *Ber.* **74B** (1941), 1575.

1-Octen-3-ol

C₈H₁₆O

Mol. Weight 128.21

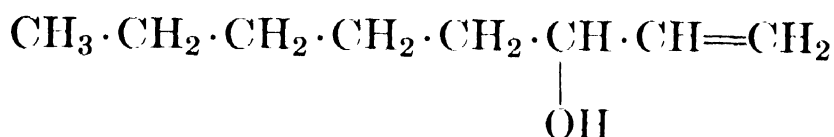
l-n-Amylvinylcarbinol. Matsutake-alcohol

1-Octen-3-ol was found by Murahashi¹ in the so-called Matsutake, a fungus, viz., *Armillaria matsutake* Ito and Imai (fam. *Agaricaceae*). This fungus is a parasite growing in Japanese forests on the root hairs of *Pinus densiflora*. 1-Octen-3-ol b. 165°–175°, b₁₂ 68°–71°, [α]_D¹⁴ –7° 49', was characterized by the preparation of its *p*-iododiphenylurethane m. 165.5°–166°.

Murahashi² also found that the octenol previously identified in hinoki leaf oil is in reality 1-octen-3-ol.

¹ *Sci. Papers Inst. Phys. Chem. Research Tokyo* **30** (1936), 263; **34** (1938), 155. *Chem. Zentr.* I (1937), 1958; II (1938), 1249. *Chem. Abstracts* **32** (1938), 3755.

² *Ibid.*

Methyl Heptenol

C₈H₁₆O

Mol. Weight 128.21

2-Methyl-1-hepten-6-ol

2-Methyl-2-hepten-6-ol

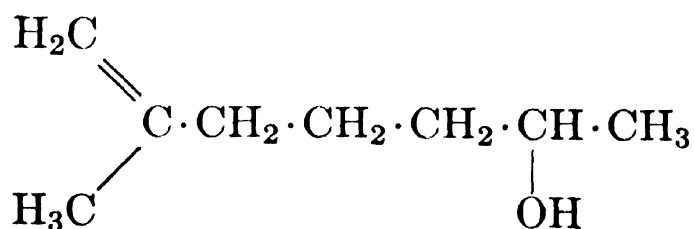

α-Methyl Heptenol

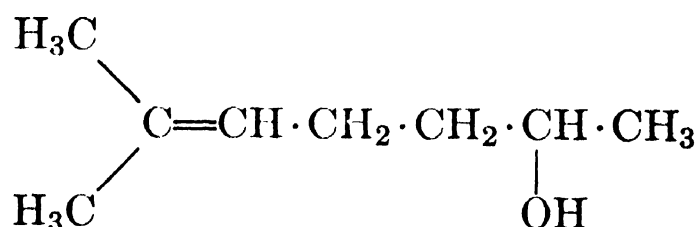

β-Methyl Heptenol

Digesting geraniol with concentrated alcoholic potassium hydroxide at 150°, Grignard and Dœuvre¹ obtained methyl heptenol which, on treatment

with ozone and fission of the oxonides, proved to be a mixture of 10 per cent of α -methyl heptenol and 90 per cent of β -methyl heptenol. (Cf. the monograph on "Methyl Heptenone.")

Occurrence.—As far as the natural methyl heptenol is concerned, small quantities have been shown to occur in the volatile oil derived from the wood of the Mexican and Cayenne linaloe tree (by Schimmel & Co.²), in East Indian lemongrass oil (by Elze³), and in West Indian lemongrass oil (by Naves⁴).

Isolation.—Schimmel & Co.⁵ isolated methyl heptenol from Mexican linaloe wood oil by boiling the fraction b_{2-3} 57° – 59° of the oil with phthalic anhydride on a water bath for 4 hrs. The acid phthalate thus obtained was separated and saponified by treatment with sodium hydroxide solution. Finally, alcohol thus freed was removed by steam distillation.

Elze,⁶ too, used the phthalic ester method, starting from the fraction b_4 65° – 70° of East Indian lemongrass oil, while Naves⁷ employed the boric ester method.

Identification.—(1) By the preparation of derivatives:

Naves⁸ prepared the allophanate m. 98° – 99° (crystallized from absolute alcohol) of naturally occurring methyl heptenol.

(2) By oxidation of methyl heptenol with chromium trioxide (in glacial acetic acid solution) to methyl heptenone which can be identified by the preparation of its semicarbazone m. 135° – 136° (Schimmel & Co.,⁹ and Elze¹⁰), m. 137° – 138° (Schimmel & Co.¹¹).

Properties.—Methyl heptenol is an oil with an odor reminiscent of octyl alcohol and methyl heptenone. Schimmel & Co.,¹² Elze,¹³ and Naves¹⁴ reported these properties for the naturally occurring methyl heptenol:

b.	178° – 180° ¹²	d_{15}	0.8579 ^{12,13}
b.	176° (corr.) ¹⁴	d_{15}	0.8581 ¹⁴
b_{759}	178° – 180° ¹³	α_D	$-2^{\circ} 0'$ ¹³
b_{12}	76° – 78° ¹⁴		$-1^{\circ} 34'$ ¹²
b_3	58° – 59° ¹²		$-1^{\circ} 15'$ ¹⁴
		n_D^{20}	1.4506 ¹⁴
			1.4495 ¹²

The fraction of Cayenne linaloe oil, in which Schimmel & Co.¹⁵ identified methyl heptenol, had these properties:

d_4^{15}	0.8655
α_D	$-11^{\circ} 40'$

So far as synthetic *dl*-2-methyl-2-hepten-6-ol is concerned, it has been prepared by several workers and by various methods—for example, by reduction of 2-methyl-2-hepten-6-one (Wallach¹⁶), by boiling of geranic acid nitril with alcoholic potassium hydroxide (Tiemann and Semmler¹⁷), by digestion

of geraniol with alcoholic potassium in an autoclave for 8 hr. (Tiemann¹⁸), and by catalytic hydrogenation of methyl heptenone (Grignard¹⁹).

Digesting geraniol with alcoholic potassium hydroxide, or heating ordinary methyl heptenone with alcoholic potassium hydroxide under pressure at 140°, Dœuvre²⁰ obtained synthetic *dl*-2-methyl-2-hepten-6-ol with these properties:

b.	177°–178° (corr.)	d_4^{14}	0.855
b ₂₄	88°–89°	n_D^{14}	1.5411
b ₁₇	83°–84°	Allophanate m. 99°–100°	
b ₁₄	78°–79°		

Levene and Haller²¹ prepared the optically active forms of methyl heptenol from the *dl*-form via the acid phthalate and its brucine salt:

d-form

b₄ 60°–61°, $[\alpha]_D^{20} +19^\circ$ (Ether, $c = 8$)

l-form

b₂₂ 87°, $\alpha_D^{23} -13^\circ 45'$, $[\alpha]_D^{23} -16^\circ 12'$ (Ether, $c = 20$)

Neuberg and Lewite²² obtained methyl heptenol (in small yield) by the action of fermenting yeast on methyl heptenone and observed optical rotations of $-6^\circ 30'$ and $+2^\circ 4'$.

Use.—Methyl heptenol, as such, is very little, if at all, used in our industries.

¹ *Bull. soc. chim.* [4], **41** (1927), 999.

² *Ber. Schimmel & Co.*, Oct. (1908), 78; Oct. (1911), 60.

³ *Riechstoff Ind.* **4** (1929), 23.

⁴ *Parfums France* **9** (1931), 69.

⁵ *Ber. Schimmel & Co.* Oct. (1908), 78.

⁶ *Riechstoff Ind.* **4** (1929), 23.

⁷ *Parfums France* **9** (1931), 69.

⁸ *Ibid.*

⁹ *Ber. Schimmel & Co.*, Oct. (1908), 78; Oct. (1911), 60.

¹⁰ *Riechstoff Ind.* **4** (1929), 23.

¹¹ *Ber. Schimmel & Co.*, Oct. (1911), 60.

¹² *Ibid.*, Oct. (1908), 78.

¹³ *Riechstoff Ind.* **4** (1929), 23.

¹⁴ *Parfums France* **9** (1931), 69.

¹⁵ *Ber. Schimmel & Co.*, Oct. (1911), 78.

¹⁶ *Liebigs Ann.* **275** (1893), 171.

¹⁷ *Ber.* **26** (1893), 2720.

¹⁸ *Ber.* **31** (1898), 2991. Cf. Barbier, *Compt. rend.* **126** (1898), 1423; **128** (1899), 110
Grignard and Dœuvre, *Bull. soc. chim.* [4], **41** (1927), 999.

¹⁹ *Bull. soc. chim.* [4], **43** (1928), 473. Cf. *Bull. soc. chim. Belg.* **37** (1928), 41.

²⁰ *Bull. soc. chim.* [4], **45** (1929), 353, 358, 359.

²¹ *J. biol. chem.* **83** (1929), 181.

²² *Biochem. Z.* **91** (1918), 263.

2,6-Nonadien-1-ol

C₉H₁₆O

Mol. Weight 140.22

"Violet Leaf Alcohol"

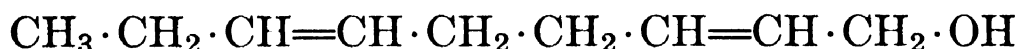

Occurrence.—This primary alcohol was discovered by Ruzicka and Schinz¹ in the ethereal oil derived from violet leaves by extraction with volatile solvents and by steam distillation of the concentrated extract. Later, Ruzicka² found that the ethereal oil derived from violet flowers contains about the same percentage of 2,6-nonadien-1-ol as the corresponding leaf oil. More recently, Ruzicka, Schinz and Susz³ suggested that the natural 2,6-nonadien-1-ol from violet leaves has the 2(*trans*)-,6(*cis*)- form, whereas the synthetic alcohol prepared from synthetic 3-hexen-1-ol has the 2(*trans*)-,6(*trans*)- configuration. On the other hand, the 2,6-nonadien-1-ol prepared from natural 3-hexen-1-ol (which occurs as phenylacetic ester in the higher boiling fractions of Japanese mint oil [*Mentha arvensis*]) also has the 2(*trans*)-,6(*cis*)- form; therefore, the 2,6-nonadien-1-ol from violet leaves and violet flowers seems to be identical with the 2,6-nonadien-1-ol prepared from naturally occurring 3-hexen-1-ol.

Isolation.—Takei and Ono⁴ isolated an alcohol from cucumbers which they described as 2,6-nonadienol b₄ 80°–100° and named "cucumber alcohol." These authors found that this diene gave the same derivatives as a synthetic nonadienol which Takei et al.⁵ had previously prepared from leaf alcohol and which they reported as 2(*trans*)-,6(*trans*).

Ruzicka and Schinz⁶ isolated 2(*trans*)-,6(*cis*)-nonadien-1-ol from ethereal violet leaf oil through the acid phthalate. The alcohol can be purified through its benzoate and by fractionation.

Identification.—Ruzicka, Schinz and Susz⁷ identified the purified synthetic 2(*trans*)-,6(*trans*)-nonadien-1-ol (prepared from synthetic 3-hexen-1-ol) by means of these derivatives:

(a) Allophanate m. 145°–148°.

(b) α -Naphthylurethane m. 73°–74°.

On the other hand, the 2(*trans*)-,6(*cis*)-nonadien-1-ol prepared from natural 3-hexen-1-ol (as derived from Japanese mint oil), after purification through the benzoate and fractionation, gave an allophanate m. 134°–135°.

The natural "violet leaf alcohol," 2(*trans*)-,6(*cis*)-nonadienol, may be oxidized by chromic acid to "violet leaf aldehyde" and identified by its semicarbazone m. 157°–158°.

Takei and co-workers found a 2,6-nonadienol considered as 2(*trans*)-,6(*trans*) to yield

(a) Allophanate 140°

(b) 4'-Iododiphenylurethane 137°.

Properties.—Ruzicka, Schinz and Susz⁸ reported for this 2(*trans*)-,6(*cis*)-nonadien-1-ol the following properties:

b ₁₁	96°–100°
d ₄ ²⁵	0.8622
n _D ²⁵	1.4631

The same authors found for purely synthetic 2(*trans*)-,6(*trans*)-nonadien-1-ol prepared from synthetic 3-hexen-1-ol, and purified through the benzoate, these properties:

b_{11}	95.5°–100°
d_4^{25}	0.8604
n_D^{25}	1.4598

Use.—Synthetic 2,6-nonadien-1-ol is used in high-grade perfume compositions for imparting delicate violet notes.

¹ *Helv. Chim. Acta* **18** (1935), 381.

² *Perfumery Essential Oil Record* **29** (1938), 174.

³ *Helv. Chim. Acta* **27** (1944), 1561.

⁴ *J. Agr. Chem. Soc. Japan* **15** (1939), 193. *Chem. Abstracts* **33** (1939), 6524; **34** (1940), 1811.

⁵ *Ibid.* **14** (1938), 717. *Chem. Abstracts* **33** (1939), 2558.

⁶ *Helv. Chim. Acta* **18** (1935), 381.

⁷ *Ibid.* **27** (1944), 1561. *Chem. Abstracts* **39** (1945), 3117.

⁸ *Ibid.*

Androl

$C_9H_{18}O$

Mol. Weight 142.23

This alcohol was formerly thought to be a terpene alcohol $C_{10}H_{20}O$ containing a tertiary hydroxy group as it does not yield either a ketone or an aldehyde on oxidation. Later, Presting ¹ declared it a primary alcohol $C_{10}H_{20}O$, but in 1936 Wienhaus and Striegler ² established the constitution of androl as a laevorotatory 1-nonen-3-ol of the following structure:

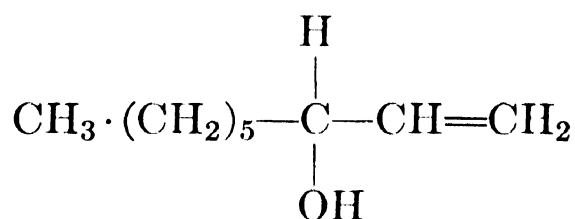

Occurrence.—Androl has been found ³ in the oil of water fennel (*Phellandrium aquaticum*).

Identification.—The alcohol forms a phenylurethane m. 42°–43° and an α -naphthylurethane m. 80.5°.

Properties.—Androl is an oil with a typical odor reminiscent of water fennel. Schimmel & Co.⁴ reported these properties:

$b.$	197°–198°	α_D	–7° 10'
d_{15}^{15}	0.858	n_D^{20}	1.44991

Use.—Androl is not used in our industries.

¹ Inaugural Dissertation, Univ. Leipzig (1931). *Ber. Schimmel & Co.* (1932), 134.

² Inaugural Dissertation of A. Striegler, Univ. Leipzig (1936). *Ber. Schimmel & Co.* (1937), 91.

³ *Ber. Schimmel & Co.*, Oct. (1904), 94.

⁴ *Ibid.*

10-Hendecen-2-ol

 $C_{11}H_{22}O$

Mol. Weight 170.29

1-Undecen-10-ol

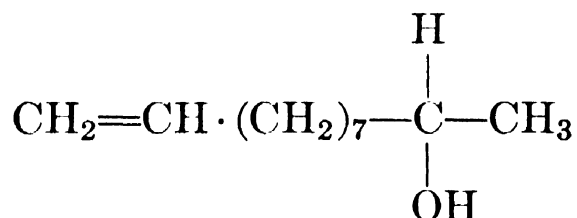

Occurrence.—This unsaturated aliphatic alcohol occurs in the oil derived from trawas leaves (*Litsea odorifera* Valetton).

Isolation.—By the usual methods of isolating alcohols.

Identification.—On oxidation with chromic acid and sulfuric acid, 1-undecen-10-ol yields a ketone, the semicarbazone of which melts at 113° ; whereas on oxidation with potassium permanganate the alcohol gives 2-ketodecyllic acid.

Properties.—According to van Romburgh,¹ 1-undecen-10-ol has these properties:

b.	233°
d_{10}	0.835
$[\alpha]_D$	$-5^\circ 10'$

Use.—No report is made in the literature about the use of this alcohol.

¹ *Koninkl. Akad. van Wetensch. Amsterdam, Wisk. en Natk. Afd.* **20** (1911), 194. *Chem. Zentr.* II (1911), 1863.

(c) ALIPHATIC TERPENE ALCOHOLS.

Bupleurol

 $C_{10}H_{20}O$

Mol. Weight 156.26

2-Methyl-6-methylenoctan-8-ol(?)

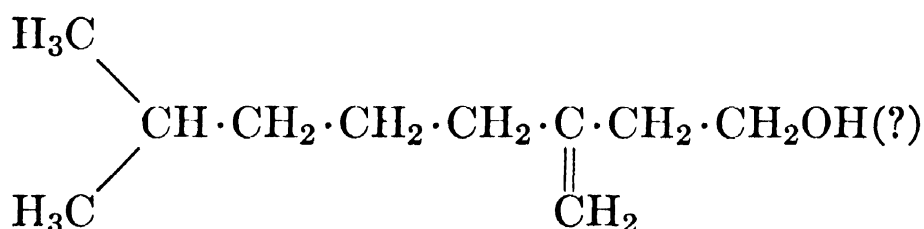

The constitution of this terpene alcohol has not been definitely established and seems worthy of further study.

Occurrence.—Francesconi and Sernagiotto¹ reported the presence of bupleurol, an isomer of citronellol, in the oil distilled from the flowers and leaves of *Bupleurum fruticosum* L.

Isolation.—The alcohol was isolated from the oil through its amorphous acid phthalate.

Identification.—

(1) By the preparation of its crystalline phenylurethane m. 45° (from low boiling petroleum ether).

(2) By the crystalline silver salt of the acid phthalate m. 135° (from a mixture of benzene and methyl alcohol). The melting is accompanied by decomposition.

Properties.—Bupleurol is a colorless liquid possessing a faint rose-like odor.

Francesconi and Sernagiotto ² reported the following properties; these do not appear, however, to be in close agreement with those observed by Rutovskii, Vinogradova and Kondratski. ³ This divergence may possibly be explained by the variation of the isolates.

b_{762}	209° – 210° ²	α_D	$\pm 0^{\circ}$ ²
d_4^{20}	0.8611 ³	α_D	$-22^{\circ} 11'$ ³
d_{17}	0.8490 ²	n_D^{20}	1.4748 ³
		n_D	1.4508 ²

Use.—Bupleurol is not used in our industries.

¹ *Atti accad. Lincei* **22**, I (1913), 34, 148.

² *Ibid.*

³ *Arbeiten Chem.-Pharmazeut. Inst. Moskaus Lief.* **11** (1925), 59. *Chem. Zentr.* I (1926), 1304.

∨ Linaloöl

$C_{10}H_{18}O$

Mol. Weight 154.24

3,7-Dimethyl-1,6-octadien-3-ol

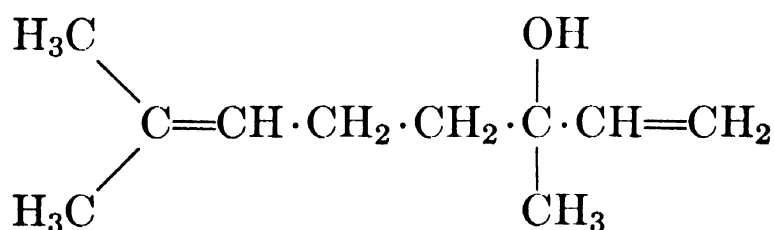

3,7-Dimethyl-1,7-octadien-3-ol

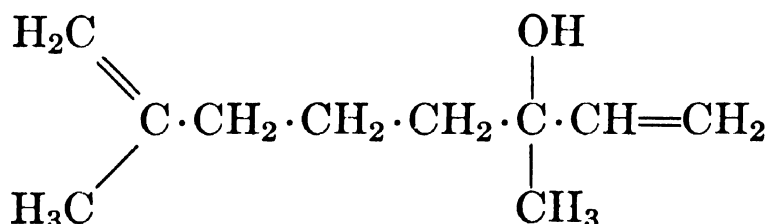

The unsaturated tertiary terpene alcohol linaloöl consists very probably of a mixture of two structural isomers, neither of which has so far been obtained

in pure form. The difficulties connected with the elucidation of its constitution have been increased by the ease with which linaloöl is isomerized to geraniol.

Occurrence.—Linaloöl and its esters, especially the acetate, are widely distributed in nature and form the main constituent of several volatile oils. Unlike geraniol and nerol, linaloöl occurs in nature in dextro- and laevorotatory form.

d-Linaloöl has been found in Mexican linaloe seed oil, in oil of bois de rose (80–85 per cent), nutmeg, sweet orange, Canadian snake root, coriander, *Orthodon linaloliferum* Fujita (82 per cent), and in other orthodon oils.

l-Linaloöl occurs in Japanese ho (*shiu*) oil (80–90 per cent), in Mexican linaloe wood oil (60–80 per cent), in oil of lavender, spike-lavender, lavandin, clary sage, bergamot, neroli, petitgrain, lemon, lime, French and German type basil, Réunion geranium, rose, Ceylon cinnamon, etc.

Linalyl acetate is the main constituent of lavender and bergamot oil, etc.

Isolation.—Linaloöl does not yield any definite crystalline derivative from which it can be regenerated quantitatively and in absolutely pure form. For practical purposes linaloöl is, therefore, best isolated by careful fractional distillation of the saponified volatile oil.

Tiemann¹ suggested purifying linaloöl through the sodium salt of the acid phthalate which can be obtained by the action of phthalic anhydride upon the sodium compound of linaloöl. (It should be kept in mind, however, that, according to Semmler,² the action of sodium on linaloöl yields a hydrocarbon to which Semmler assigned the name linaloölene, but which was later shown to be identical with dihydromyrcene.) The acid linalyl phthalate is saponified with alcoholic potassium and the regenerated linaloöl removed from the alkaline solution by extraction with ether as it would be decomposed by steam distillation.

Deppe Söhne and Zeitschel³ suggested isolating linaloöl—for example, from ho (*shiu*) oil—by preparing (with acetoboric anhydride) the acid borate of linaloöl and by separating the other constituents from this ester through distillation. The borate is then purified by recrystallization, and the linaloöl regenerated by saponification.

Identification.—Linaloöl can be identified:

(1) By the preparation of derivatives:

(a) Phenylurethane m. 65°–66°, according to Walbaum and Hüthig.⁴

(b) α -Naphthylurethane m. 53°, according to Schimmel & Co.⁵

(2) On oxidation with chromic acid mixture, linaloöl yields citral which can be characterized through its semicarbazone m. 171°, and through the α -citryl- β -naphthocinchonic acid m. 198°–200° (see "Citral").

For the quantitative determination of linaloöl, see also Vol. I, Chapter 4, "The Examination and Analysis of Essential Oils, Synthetics, and Isolates," p. 276.

Properties.—Linaloöl is an oil possessing a pleasant odor reminiscent of lily of the valley. The physicochemical properties of linaloöl vary quite widely and depend greatly upon its origin. The following range of properties has been reported in the literature for the active isomer (Gildemeister,⁶ Stephan,⁷ Gildemeister and Hoffmann,⁸ Semmler,⁹ Rosanov,¹⁰ Barbier,¹¹ Tiemann and Schmidt,¹² Schimmel & Co.,¹³ and Tiemann¹⁴):

b.	198°–199° ⁶	α_D (<i>l</i> -linaloöl)	–3° 0' to –18° 0' ⁸
b ₁₃	88.3°–89.5° ⁶	from lime oil	
b ₁₀	85°–87° ⁷	$[\alpha]_D^{15}$ (<i>l</i> -linaloöl)	–20° 7' ⁶
b ₄	69°–71° ⁸	from lime oil	
d ₂₀	0.8622–0.8733 ^{9,10,14}	α_D (<i>d</i> -linaloöl)	+9° 0' to +13° 0' ⁸
d ₁₅ ¹⁵	0.866–0.873 ⁸	from orange oil	
d ₀	0.8820 ¹¹	$[\alpha]_D$ (<i>d</i> -linaloöl)	+19° 18' ⁷
		from orange oil	
		n_D^{20}	1.4611–1.4673 ^{9,10,12,13,14}

Particular mention should be made, however, of properties observed by Schimmel & Co.¹⁵ on the laevo isomer that had been carefully purified through the phenylurethane:

b.	199°–200°	α_D	–17° 41'
d ₁₅ ¹⁵	0.8666	n_D^{20}	1.46238

The low optical rotation reported in most cases probably refers to mixtures of both optical modifications whereby one predominates.

dl-Linaloöl does not seem to occur in nature but may be obtained by isomerization of geraniol, or by reduction of a dehydrolinaloöl (Wallach and Naschold,¹⁶ Gildemeister and Hoffmann,¹⁷ and Ruzicka and Fornasir¹⁸):

b ₇₂₀	194°–197° ¹⁸	d ₁₅	0.865 ¹⁸
b ₁₃	86°–88° ¹⁸	n_D^{19}	1.4658 ¹⁶
Sol.	Soluble in 10–15 vol. of 50% alcohol, in 4–5 vol. of 60% alcohol, in 1–2 vol. of 70% alcohol ¹⁷		

Being a tertiary alcohol, linaloöl is very sensitive to the action of organic acids; with acid reagents in general, linaloöl easily isomerizes to geraniol. For the same reason the esters of linaloöl cannot be obtained in pure form by the ordinary methods. When heated with glacial acetic acid and acetic anhydride, linaloöl is converted into a mixture of esters of geraniol, terpineol (*d*- α -terpineol from *l*-linaloöl), and nerol. This explains the formation of citral on oxidation of linaloöl with chromic acid mixture. Similar reactions take place when linaloöl is treated with formic acid in the cold, but with formic acid at room temperature, or with concentrated sulfuric acid at 60°–70° linaloöl will be dehydrated to terpinene and dipentene. When shaken with a 5 per cent solution of sulfuric acid, linaloöl is hydrated to terpin hydrate.

As an unsaturated alcohol containing two ethylenic linkages, linaloöl absorbs 2 mols of bromine yielding an unstable, liquid tetrabromide. The ac-

tion of halogen acids leads to the formation of a chloride $C_{10}H_{17}Cl$, b_6 94° – 96° , and linalyl or geranyl bromide $C_{10}H_{17}Br$, b_6 102° – 103° . The same compounds originate either from linaloöl or from geraniol.

When treated with very dilute potassium permanganate, linaloöl is oxidized to acetone and laevulinic acid, with chromic acid mixture to citral, methyl heptenone, acetone, laevulinic acid, etc.

With sodium bisulfite, linaloöl, according to Dupont and Labaune,¹⁹ yields a crystalline, but very hygroscopic derivative $C_{10}H_{18}O$, $2NaHSO_3$. Prileschaev²⁰ showed that, with benzoylhydroperoxide, linaloöl is oxidized to *linaloöl monoxide* $C_{10}H_{18}O$, b_{25} 95° , d_{16}^{16} 0.9507, $[\alpha]_D$ $-4^\circ 59'$, n_D^{16} 1.4554, and *linaloöl dioxide* $C_{10}H_{18}O_2$, b_{25} 131° – 133° , d_{16}^{16} 1.0423, $[\alpha]_D$ $+5^\circ 20'$, n_D^{16} 1.4616.

Linaloöl monoxide has been found in oil of linaloe; it is probably formed by aerial oxidation while the oil is still in the tree.

Use.—Linaloöl is one of the most important aromatic isolates, used widely in the perfume, cosmetic, soap, and flavor industries. The esters of linaloöl, especially the acetate, are equally important. (See "Linalyl Acetate.")

¹ *Ber.* **31** (1898), 837.

² *Ber.* **27** (1894), 2520.

³ British Patent No. 252570 (1925).

⁴ *J. prakt. Chem.* II, **67** (1903), 325.

⁵ *Ber. Schimmel & Co.*, Oct. (1906), 32.

⁶ *Arch. Pharm.* **233** (1895), 179.

⁷ *J. prakt. Chem.* II, **58** (1898), 110; **62** (1900), 529.

⁸ "Die Ätherischen Öle," 3d Ed., Vol. I, 423.

⁹ *Ber.* **24** (1891), 206.

¹⁰ *J. Russ. Phys. Chem. Soc.* **61** (1929), 2310.

¹¹ *Bull. soc. chim.* [3], **9** (1893), 914.

¹² *Ber.* **31** (1898), 834.

¹³ *Ber. Schimmel & Co.*, April (1904), 51.

¹⁴ *Ber.* **31** (1898), 834.

¹⁵ *Ber. Schimmel & Co.*, Oct. (1911), 139.

¹⁶ *Ber. Schimmel & Co.*, April (1898), 25.

¹⁷ "Die Ätherischen Öle," 3d Ed., Vol. I, 423.

¹⁸ *Helv. Chim. Acta* **2** (1919), 188.

¹⁹ *Sci. Ind. Rept. Roure-Bertrand Fils* **7** (1913), 3.

²⁰ *Ber.* **42** (1909), 4813.

SUGGESTED ADDITIONAL LITERATURE

Yoshiharu Ogata, "Reaction Products of Linaloöl by the Catalytic Action of Reduced Copper," *J. Chem. Soc. Japan* **63** (1942), 416. *Chem. Abstracts* **41** (1947), 3039.

Koshiro Ishimura and Kaneo Tamira, "The Catalytic Action of Reduced Nickel in the Hydrogenation of Geraniol, Citronellol, and Linaloöl," *Bull. Chem. Soc. Japan* **18** (1943), 194. *Chem. Abstracts* **41** (1947), 4445.

M. F. Carroll, "Structure of Certain Acyclic Isolates," *Perfumery Essential Oil Record* **38**, No. 7 (1947), 226.

Y. R. Naves, A. V. Grampoloff and P. Bachmann, "Etudes dans les Séries des Méthyl-3-linalols, des Méthyl-3-citrals et des Méthyl-6-ionones," *Helv. Chim. Acta* **30** (1947), 1599.

Geraniol

 $C_{10}H_{18}O$

Mol. Weight 154.24

The structure of geraniol, like that of citronellol, has been the subject of much controversy which still continues.

Geraniol, an unsaturated primary terpene alcohol, contains two ethylenic linkages. An isomer of linalool $C_{10}H_{18}O$, geraniol differs from it by optical inactivity, a higher boiling point and higher specific gravity. Geraniol is also isomeric with nerol since these two diolefinols are related as geometric forms. Moreover, geraniol is at present generally regarded as not of uniform composition but as composed of:

2,6-Dimethyl-1,6-octadien-8-ol and 2,6-Dimethyl-2,6-octadien-8-ol

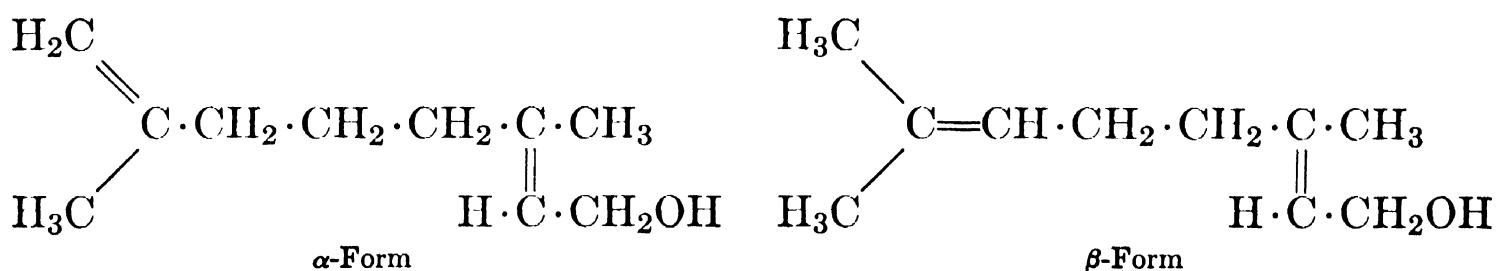

It seems probable that geraniol occurs in nature as a mixture of these two structural isomers in which either the one or the other form may predominate.

Workers in the field of spectroscopy now usually define these two isomers as " α " and " β ." 2,6-Dimethyl-1,6-octadien-8-ol is thus classified as the α -form, and 2,6-dimethyl-2,6-octadien-8-ol is described as the β -form.¹

Occurrence.—Geraniol and its esters are widely distributed and occur in many volatile oils, forming the main constituent in some. Thus geraniol has been found in oil of palmarosa (up to 95 per cent), rose, geranium (40–50 per cent), citronella (30–40 per cent), lemongrass, *Eucalyptus staigeriana*, *E. macarthurii*, linaloe, lavender, coriander, ylang ylang, neroli, petitgrain, etc.

Isolation.—(1) Geraniol can readily be isolated in pure form from volatile oils or fractions by taking advantage of the fact that it yields a crystalline derivative with anhydrous calcium chloride. This compound is insoluble in ether, petroleum ether, benzene, or chloroform, and may be decomposed with water into geraniol and calcium chloride. Bertram and Gildemeister² suggested the following procedure:

Equal parts of carefully dried oil and finely pulverized anhydrous calcium chloride are mixed and thoroughly ground in a mortar. Once the reaction starts the temperature of the mixture will rise to 30°–40°. It is then placed in a desiccator and set aside for several hours in a cool place. The resulting solid mass is triturated, ground with anhydrous ether, benzene, or low boiling petroleum ether, placed on a suction filter, washed rapidly with ether and freed from constituents which have not reacted with calcium chloride. The resulting mixture of geraniol, calcium chloride complex and

excess calcium chloride is decomposed with water, the separated oil rapidly washed with warm water and finally steam distilled.

This process has been investigated recently by Jones and Wood³ as a means of preparing pure geraniol.

(2) Geraniol can also be isolated and purified, but much less conveniently, through its solid acid phthalate m. 47° (see also "Citronellol") which forms a crystalline silver salt. By fractional crystallization of its acid phthalate, geraniol may be separated from citronellol. However, this method suggested and modified by Tiemann and Krüger,⁴ Erdmann and Huth,⁵ Flatau and Labbé,⁶ and Stephan,⁷ yields a product not as pure as that obtained by the calcium chloride process (see above).

The principle of this method aims at preparing first the acid phthalate of geraniol by either permitting phthalic anhydride to react with the sodium compound of crude geraniol, or by warming geraniol on a steam bath with phthalic anhydride without solvent, or in benzene solution. The acid phthalate of geraniol itself, or its sodium salt, which can be obtained in pure form from the crystalline silver salt, is finally saponified with alcoholic potassium hydroxide.

(3) For the assaying of geraniol in a mixture with citronellol the total alcohol content of the mixture should first be determined by acetylation. In another test the geraniol is destroyed by formylation with strong formic acid. Citronellol is thereby not attacked and can be determined alone (see Vol. I, Chapter 4, "Examination and Analysis of Essential Oils, Synthetics, and Isolates," p. 278).

Identification.—(1) Geraniol may be most conveniently characterized, especially in small quantities, by the preparation of its diphenylurethane $(C_6H_5)_2N \cdot CO \cdot O \cdot C_{10}H_{17}$, m. 82.2°. Erdmann and Huth⁸ suggested preparing this ester by heating 1.0 g. of oil with 1.5 g. of diphenylcarbonyl chloride and 1.35 g. of pyridine on a steam bath.

Geraniol can also be identified as α -naphthylurethane m. 47°–48°, as di- β -naphthylurethane m. 105°–107°, and as phenylurethane m. 124°, according to Gildemeister and Hoffmann.⁹ Takei, Sakato and Ono¹⁰ prepared the 4'-iododiphenylurethane m. 119° with geraniol isolated from oil of green tea.

(2) Gildemeister and Hoffmann¹¹ suggested further characterizing geraniol by oxidation to citral and by conversion of the citral to α -citryl- β -naphthocinchonic acid m. 199°–200° (see "Citral"). However, by this procedure linaloöl, too, yields citral if the oxidation is carried out with chromic acid mixture.

(3) Naves and Grampoloff¹² used the allophanate in order to differentiate and identify the isomeric alcohols, nerol, and geraniol. Geranyl allophanate m. 124°–124.5° and nerol allophanate m. 84°–84.5°.

(4) Lennartz¹³ characterized geraniol through its 3-nitrophthalate m. 109°–109.5°, Fieser and Gates¹⁴ by its reaction product with leucoisonaphthazarin m. 110°–111.5°.

Properties.—Geraniol is a colorless oil, possessing an agreeable rose-like odor. The following properties have been recorded by Bertram and Gildemeister,¹⁵ Tiemann and Semmler,¹⁶ Erdmann,¹⁷ and Stephan:¹⁸

b.	230° ¹⁵	d_4^{16}	0.8812 ¹⁷
b_{18}	121° ¹⁵	d_{15}	0.880–0.883 ¹⁸
b_{17}	120.5°–122.5° ¹⁶	α_D	$\pm 0^\circ$ ¹⁸
b_{10}	110°–111° ¹⁵	n_D^{20}	1.4766 ¹⁶
		n_D^{17}	1.4766–1.4786 ¹⁸

Gildemeister and Hoffmann¹⁹ reported these properties for geraniol manufactured on a large scale:

b ₇₅₇	229°–230°	d ₁₅ ¹⁵	0.883–0.886
b ₁₂	114°–115°	n _D ²⁰	1.476–1.479
Sol.	Soluble in 8 to 15 vol. of 50% alcohol and in 2.5 to 3.5 vol. of 60% alcohol		

When exposed to air, geraniol discolors and its odor gradually deteriorates due to absorption of oxygen.

Because of the two ethylenic linkages, geraniol is a highly reactive substance. With sodium bisulfite it forms a stable compound C₁₀H₁₈O, 2NaHSO₃ from which the alcohol cannot be regenerated with alkali. The action of mineral acids and dehydrating agents on geraniol is very diverse and depends greatly on the experimental conditions. When shaken with a 5 per cent sulfuric acid solution, geraniol yields mainly terpin hydrate. Treatment with phosphoric acid, gaseous hydrogen chloride, etc., causes the formation of dipentene and other terpenes. The action of acid reagents may bring about cyclization and formation of cyclogeraniol. Under the influence of concentrated formic acid, potassium bisulfate or phosphoric acid anhydride, water is cleaved off. In general, however, geraniol is more stable toward acids, especially organic acids, than linaloöl, which feature facilitates the preparation of esters. In the cold, alkalis do not easily act on geraniol. Oxidation of geraniol with chromic acid mixture gives mainly citral, also β-methyl heptenone. Oxidation with very dilute potassium permanganate solution yields first a polyhydric alcohol and finally various products of complete degradation, according to the experimental conditions employed. For details of these many reactions the reader is referred to Simonsen's "The Terpenes."

Use.—Geraniol is one of the most widely used aromatic isolates, indispensable in the compounding of rose scents. In fact, it forms part of almost any perfume compound. Thus, geraniol serves extensively in the perfume, cosmetic, soap, and flavor industries.

¹ See in this connection Dœuvre, *Bull. soc. chim.* [4], **45** (1929), 403. Also Dupont, Desreux, Dulou, *Bull. soc. chim.* [5], **4** (1937), 2016.

² *J. prakt. Chem.* [2], **53** (1896), 233; **56** (1897), 507.

³ *Ind. Eng. Chem.* **34** (1942), 488.

⁴ *Ber.* **29** (1896), 901.

⁵ *J. prakt. Chem.* [2], **56** (1897), 15.

⁶ *Compt. rend.* **126** (1898), 1725. *Bull. soc. chim.* [3], **19** (1898), 633.

⁷ *J. prakt. Chem.* [2], **60** (1899), 248.

⁸ *J. prakt. Chem.* [2], **56** (1897), 8.

⁹ "Die Ätherischen Öle," 3d Ed., Vol. I, 434.

¹⁰ *Bull. Inst. Phys. Chem. Research Tokyo*, **16** (1937), 7. Pub. with *Sci. Papers Inst. Phys. Chem. Research Tokyo* **13** (1937), Nos. 671–5. *Chem. Abstracts* **31** (1937), 6815.

¹¹ "Die Ätherischen Öle," 3d Ed., Vol. I, 435.

¹² *Helv. Chim. Acta* **25** (1942), 1500.

¹³ *Ber.* **76B** (1943), 248.

¹⁴ *J. Am. Chem. Soc.* **63** (1941), 2948.

¹⁵ *J. prakt. Chem.* II, **56** (1897), 508.

¹⁶ *Ber.* **26** (1893), 2711.

¹⁷ *J. prakt. Chem.* II, **56** (1897), 3. *Ber.* **31** (1898), 359.

¹⁸ *J. prakt. Chem.* II, **58** (1898), 110; **60** (1899), 244.

¹⁹ "Die Ätherischen Öle," 3d Ed., Vol. I, 431.

SUGGESTED ADDITIONAL LITERATURE

L. S. Glichitch and Y. R. Naves, "The Determination of Citronellol and Rhodinol in Presence of Geraniol and Nerol," *Parfums France* **8** (1930), 326. *Chem. Abstracts* **25** (1931), 1033.

Koshiro Ishimura and Kaneco Tamira, "The Catalytic Action of Reduced Nickel in the Hydrogenation of Geraniol, Citronellol, and Linalool," *Bull. Chem. Soc. Japan* **18** (1943), 194. *Chem. Abstracts* **41** (1947), 4445.

V. N. Guha Roy, and M. N. Goswami, "Geraniol and Geraniol Esters," *Indian Soap J.*, April to June (1945).

Y. R. Naves, "Identification of Citronellol in the Presence of Geraniol and Nerol," *Helv. Chim. Acta* **29** (1946), 1450. *Chem. Abstracts* **41** (1947), 7657.

M. F. Carroll, "Structure of Certain Acyclic Isolates," *Perfumery Essential Oil Record* **38**, No. 7 (1947), 226.

Nerol

$C_{10}H_{18}O$

Mol. Weight 154.24

2,6-Dimethyl-1,6-octadien-8-ol

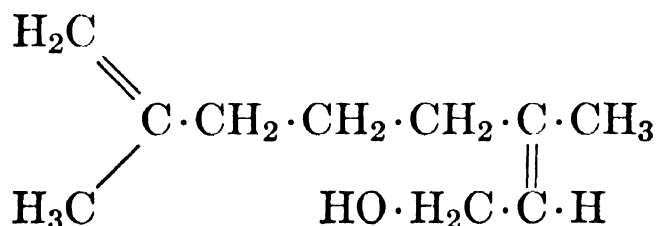

2,6-Dimethyl-2,6-octadien-8-ol

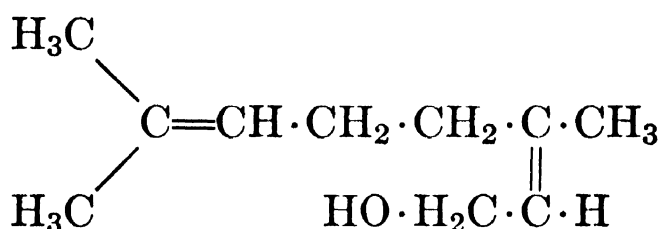

Occurrence.—This unsaturated, primary terpene alcohol, a stereoisomer of geraniol, very probably occurs in nature as a mixture of the 1,6- and 2,6-form in which the 2,6- isomer predominates.

Nerol and its acetic ester have been found in several volatile oils, for instance, in oil of helichrysum (30–50 per cent), neroli bigarade, petitgrain, rose, linaloe, lavender, bergamot, Ceylon citronella, etc. Nerol was discovered in neroli bigarade oil by Hesse and Zeitschel.¹

Isolation.—(1) According to von Soden and Zeitschel,² nerol can be isolated from oil of helichrysum or petitgrain by the following process:

Oil of petitgrain is fractionated, and the linaloöl and terpene fractions are removed. The fractions containing primary alcohols are then saponified and the primary alcohols transformed into acid phthalates or other acid esters of dibasic acids. After purification and saponification with alkali, a geraniol-nerol mixture containing about 40% nerol and 60% geraniol is obtained. The greater part of the geraniol may be removed by treatment with calcium chloride. The crude nerol is rectified by dry distillation *in vacuo* or by steam distillation. The yield of pure nerol will be about 2 to 3% as calculated upon the weight of the petitgrain oil.

(2) According to German Patent No. 209,383, September 22, 1907 (Heine & Co.), nerol may be obtained in a similar way, viz., through the acid phthalate, from helichrysum oil. The esters are dissolved in dilute soda solution and purified by extracting the soda solution with ether, petrol ether, etc., or by fractional steam distillation. Since oil of helichrysum contains no geraniol, this oil offers a better starting material than petitgrain oil and facilitates the isolation of pure nerol. However, the oil must first be saponified as it contains most of the nerol in ester form.

(3) According to von Soden and Treff,³ nerol can be separated quite easily from the terpene alcohol fraction of volatile oils, after most of the geraniol also present in this fraction has been removed with calcium chloride. The crude nerol, which usually still contains 25–30% of geraniol, is converted into its crystalline diphenylurethane. After purification by crystallization from methyl alcohol and light petrol ether, the diphenylurethane melts at 52°–53°. Hydrolysis with alcoholic potassium hydroxide solution yields pure nerol.

Identification.—According to von Soden and Treff,⁴ and Béhal,⁵ nerol is most readily characterized by the preparation of its tetrabromide m. 116°–118°, by its allophanate m. 101.5°, and by its diphenylurethane m. 52°–53°. The diphenylurethane is often slow in forming crystals, but the addition of a few geranyl-diphenylurethane crystals may accelerate the process.

Frank and Reclaire⁶ reported the tetrabromide as melting at 119°–121°. Müller⁷ has found recently that the "EM"-reagent serves very satisfactorily as an index of purity for nerol.

Properties.—Nerol is an oil possessing a pronounced rose-like odor, but more refreshing than that of geraniol. It is very difficult to obtain nerol in absolutely pure form. Von Soden et al.⁸ found these properties for an especially well purified nerol:

b ₇₅₅	224°–225°	d ₁₅	0.8813
b ₂₅	125°	α _D	±0°

Béhal⁹ reported for a nerol obtained by saponification of the allophanate:

b ₁₇	115°–117°	α _D	±0°
d ₁₉	0.881	n _D	1.47539

Frank and Reclaire¹⁰ observed on a pure nerol:

b ₁₂	112°–114°	α _D	±0°
d ₁₅ ¹⁵	0.8771–0.8788	n _D ²⁰	1.462

Contrary to geraniol, nerol does not form a crystalline compound with calcium chloride, which fact serves to separate these two terpene alcohols at least approximately. The diphenylurethanes of nerol and geraniol differ by their solubility in certain solvents such as petroleum ether and methyl alcohol. Nerol resembles geraniol in regard to many chemical reactions. Oxidation of nerol gives citral or an aldehyde of similar odor. Both geraniol and nerol, on oxidation with potassium permanganate, followed by chromic acid mixture, give the same products, viz., acetone and laevulinic acid, in identical yields. Shaking of nerol with dilute sulfuric acid results in the formation of terpin hydrate. Nerol, like geraniol, is very sensitive to the action of formic acid at elevated temperatures.

Use.—Nerol is used as a valuable constituent in synthetic rose and orange blossom compounds. However, the high price of nerol restricts its use in cosmetics and soaps.

¹ *J. prakt. Chem.* [2], **66** (1902), 502.

² See also *Ber.* **36** (1903), 265.

³ *Ber.* **39** (1906), 909.

⁴ *Ibid.* See also *Chem. Ztg.* **27** (1903), 897.

⁵ *Bull. soc. chim.* [4], **25** (1919), 452.

⁶ *Parfums France* **7** (1929), 32.

⁷ *Seifensieder-Ztg.* **68** (1941), 479, 491. *Chem. Abstracts* **37** (1943), 6410.

⁸ *Ber.* **39** (1906), 910. *Chem. Ztg.* **27** (1903), 897.

⁹ *Bull. soc. chim.* [4], **25** (1919), 452.

¹⁰ *Parfums France* **7** (1929), 32.

SUGGESTED ADDITIONAL LITERATURE

L. S. Glichitch and Y. R. Naves, "The Determination of Citronellol and Rhodinol in Presence of Geraniol and Nerol," *Parfums France* **8** (1930), 326.

G. Dupont, V. Desreux and R. Dulou, "Spectrographic and Chemical Study of Aliphatic Terpenes. Alcohols and Aliphatic Aldehydes," *Bull. soc. chim.* [5], **4** (1937), 2016.

Y. R. Naves, "Identification of Citronellol in the Presence of Geraniol and Nerol," *Helv. Chim. Acta* **29** (1946), 1450. *Chem. Abstracts* **41** (1947), 7657.

Lavandulol

 $C_{10}H_{18}O$

Mol. Weight 154.24

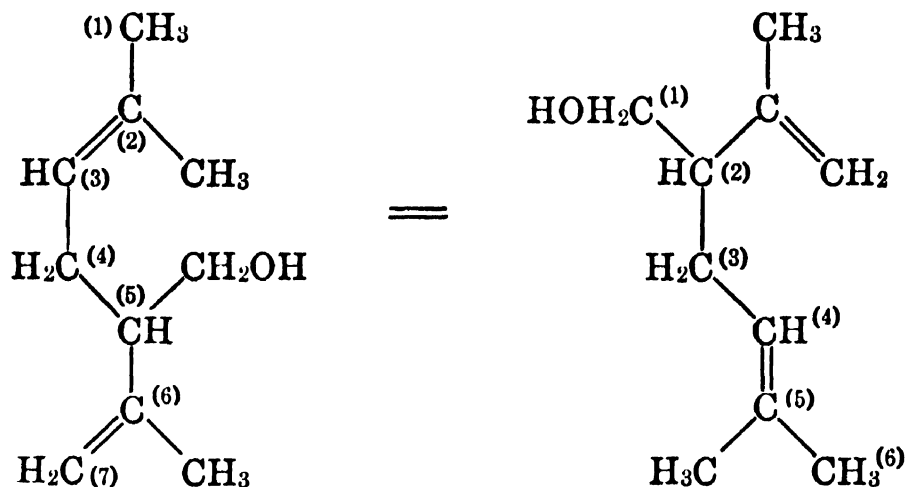
2,6-Dimethyl-5-methylol-
2,6-heptadiene2-Isopropenyl-5-methyl-4-
hexen-1-ol

Occurrence.—According to Schinz and Seidel,¹ and Seidel, Schinz and Müller,² *l*-rotatory lavandulol occurs free and as ester (mostly acetate), to the amount of about 1 per cent, in French oil of lavender (*Lavandula vera*).

Isolation.—The same authors isolated lavandulol from oil of lavender by regenerating this primary alcohol from the acid phthalic ester prepared from the free alcohol and from the hydrolyzed ester fraction of the oil. Lavandulol was separated as allophanate and recrystallized from a mixture of organic solvents such as cyclohexane and ethyl acetate. The free alcohol is obtained by hydrolysis with about fourfold excess of 10% aqueous sodium hydroxide on a boiling water bath for a period of 1 hr.

Identification.—Lavandulol can be characterized by the preparation of the following derivatives:

- (1) Allophanate m. 117°–118°, 119°–120°, if highly purified.
- (2) 3,5-Dinitrobenzoate m. 59°–60°.
- (3) Anthraquinone β -carboxylic ester m. 62°–63°.

Properties.—The above-named authors reported the following properties of lavandulol:

b_{13}	94°–95°	α_D^{16}	–10° 12'
d_4^{17}	0.8785	n_D^{17}	1.4683

Although the physicochemical properties of lavandulol resemble those of geraniol, lavandulol is distinguished from the latter primary alcohol through the formation of an acid phthalic ester even at temperatures as high as 200° without decomposition. Lavandulol furthermore differs from geraniol by the fact that it does not form a calcium chloride addition compound.

The odor of lavandulol resembles that of geraniol but possesses a somewhat spicy note. The acetate of lavandulol has an odor closely allied to that of linalyl acetate rather than geranyl acetate but the odor of the lavandulol ester is reported to be finer and more delicate than that of linalyl acetate.

Lavandulol has been synthesized by Ruzicka and Roethlisberger,³ and Schinz and Bourguin,⁴ and by Schinz and Schäppi.⁵

Use.—Nothing has been reported yet in literature about the use of synthetic lavandulol in perfume compositions or in artificial lavender oils.

¹ *Helv. Chim. Acta* **25** (1942), 1572.

² *Ibid.* **27** (1944), 663.

³ *Ibid.* **18** (1935), 439.

⁴ *Ibid.* **25** (1942), 1591.

⁵ *Ibid.* **30** (1947), 1483.

SUGGESTED ADDITIONAL LITERATURE

H. Schinz and P. H. Müller, "Synthese eines aliphatischen Sesquiterpenalkohols mit unregelmässiger Isoprenkette," *Helv. Chim. Acta* **27** (1944), 57.

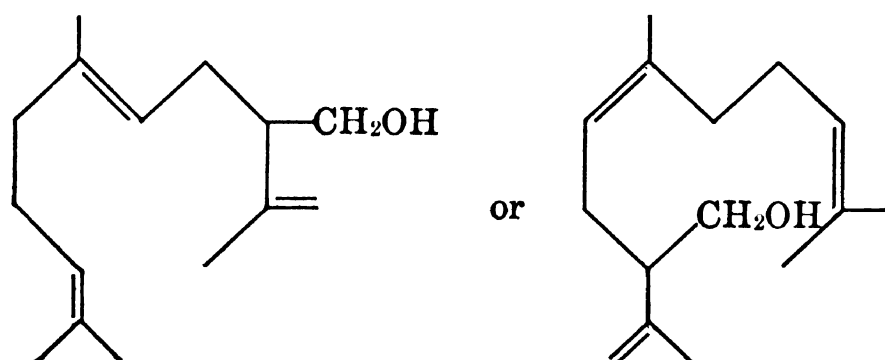

Delicate farnesol-like odor

This synthesis is based apparently on the good results with lavandulol.

H. Schinz, "Lavandulol, a New Monoterpenic Alcohol from *Lavandula vera*," *Perfumery Essential Oil Record* **37** (1946), 167.

H. L. Simon, Ad. Kaufmann, Jr., and H. Schinz (Eidg. Techn. Hochschule, Zurich), "Synthesis of *dl*- β,γ -Dihydrolavandulol," *Helv. Chim. Acta* **29** (1946), 1133 (in German). *Chem. Abstracts* **41** (1947), 85.

Citronellol

(Rhodinol)

$C_{10}H_{20}O$

Mol. Weight 156.26

The structure of citronellol and rhodinol has been the subject of numerous investigations and a prolonged controversy which still continues. Today it is generally agreed that these two important terpene alcohols are functionally identical but that both are mixtures of the following isomers:

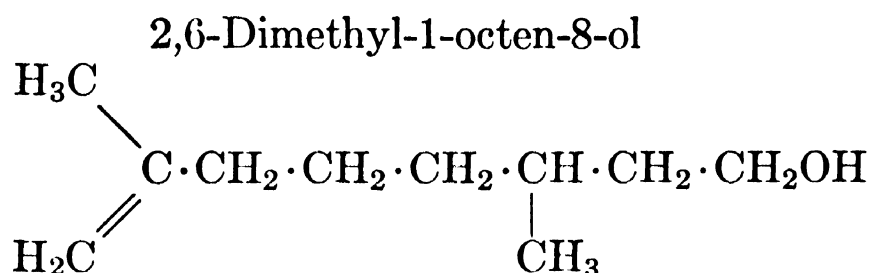

Limonene or " α " form (Isopropenyl form)

and

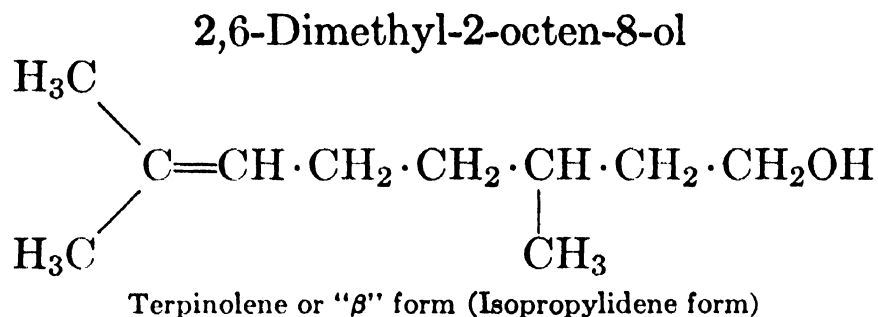

Formerly it was believed that the natural *d*- and *dl*-citronellol consisted mainly of the limonene form, the natural *l*-citronellol (rhodinol) mainly of the terpinolene form. Later Grignard and Dœuvre¹ submitted proof that *d*-citronellol as well as *l*-citronellol occurs in essential oils originally as a mixture of about 80 per cent terpinolene form and about 20 per cent limonene form. The so-called rhodinol, according to these authors, is a citronellol composed of equal parts terpinolene form and limonene form. This composition, however, is attained only on isolation through the acid phthalate or benzoate, whereby the components are isomerized. Later investigations seem to incline toward the conclusion that the natural isolates are composed wholly of the β- form. Thus, the discussion regarding the constitution of citronellol and rhodinol cannot yet be regarded as closed. For details, see the papers by Savard,² Dœuvre,³ Kuhn and Roth,⁴ Lagneau,⁵ Angla,⁶ Naves et al.,⁷ and Simonsen.⁸ It should also be mentioned that the commercial "rhodinol," as isolated from Réunion geranium oil, is not always identical with the rhodinol of the scientific literature. The commercial product frequently contains geraniol and some *d*-citronellol, aside from *l*-citronellol.

Occurrence.—Citronellol occurs naturally in *d*-, *dl*- and *l*- form. The latter is also called rhodinol.

d-Citronellol has been found in Java type citronella oil, in oil of geranium, Spanish verbena, savin, *Eucalyptus citriodora*, etc.

A most unusual source has been reported by Fester, Bertuzzi and Pucci⁹ in "yacarol" or the musk secretion from the glands of the crocodile. The *d*-citronellol isolated therefrom is unique for, although yielding all other characteristics similar to isolates from various natural sources, it possesses a higher rotatory power, i.e., +6° 50'. This alcohol supposedly originates through decomposition of cholesterol in this source.

l-Citronellol occurs as main constituent in Réunion geranium oil (35–40 per cent, together with some *d*-citronellol), likewise in large amounts in pink geranium¹⁰ (*Pelargonium roseum* Willd.), in Bulgarian rose oil (10–35 per cent and more), in *Eucalyptus citriodora* oil, etc.

Isolation.—*d*-Citronellol can be isolated by repeated treatment, for example, of Java citronella oil with alcoholic potassium hydroxide at 160° and by subsequent decomposition of the alcoholate.

l-Citronellol may be isolated by fractional distillation of Réunion geranium oil and by separating it from geraniol and other terpene alcohols through the acid phthalate, or according to the phosphorus trichloride method.

(1) Tiemann's phthalic ester method of separating citronellol from geraniol is carried out as follows:

A mixture of geraniol and citronellol, when heated with an equal weight of phthalic anhydride, will dissolve at about 150°. On raising the temperature of the clear liquid to 200°, the geraniol will be decomposed under formation of a hydrocarbon. Completion of the reaction requires about 2 hr. The acid phthalate of citronellol thus formed is taken up with dilute potassium hydroxide solution and repeatedly shaken with ether in order to remove all neutral impurities. The citronellol can then be regenerated from its potassium phthalate by heating with strong alkali hydroxide solution; or the acid phthalate may first be isolated by acidifying and extracting with ether, and by saponification with alcoholic potassium hydroxide at ordinary or at slightly elevated temperature.

(2) The phosphorus trichloride method, developed by Tiemann and Schmidt,¹¹ is based upon the fact that citronellol in ethereal solution by the action of phosphorus trichloride (not phosphorus oxychloride) forms a chloro-citronellyl-phosphoric acid ester which can be dissolved in aqueous solution as sodium salt. Geraniol, under the experimental conditions, is converted partly into hydrocarbons, partly into geranyl chloride which fact permits its removal from the alkaline solution by extraction with ether. The complex citronellyl ester can readily be separated from the other compounds and on saponification yields citronellol. Best results are obtained if 2 mols of phosphorus trichloride are used for 3 mols of alcohol. Tiemann and Schmidt¹² suggested the following procedure:

Add a well-cooled solution of 100 parts of the alcohols (including geraniol) to be examined for citronellol, dissolved in 100 parts of absolute ether, to a mixture of 60 parts phosphorus trichloride and 100 parts of absolute ether, the mixture to be cooled to -10°. Make the addition slowly and in small portions so that the temperature of the solution never rises above 0°. Set the mixture aside for four to five days at room temperature. At the expiration of this time, pour it upon well crushed ice and wash the separated ether layer once with ice water. Shake the ether solution with dilute sodium hydroxide which absorbs from it a chlorine-containing citronellyl-phosphoric acid ester and leaves in the ether a mixture b_{15} 90°-105° (in pure state b_{15} 98°-103°), consisting of geranyl chloride and a hydrocarbon. Free the water solution of the sodium salt of the citronellyl-phosphoric acid ester from every trace of adhering neutral impurities by shaking with ether. Saponify the salt of the phosphoric acid ester by the addition of strong alkali with subsequent heating on a water bath. Separate the citronellol thus freed by steam distillation. This technique, however, has not been acceptable to Glichitch and Naves.¹³

(3) Walbaum and Stephan¹⁴ recommended separating citronellol from geraniol by heating the mixture with strong formic acid whereby geraniol is decomposed while citronellol forms citronellyl formate.

Identification.—(1) According to Grignard and Dœuvre,¹⁵ citronellol can easily be identified by the preparation of the allophanate $m.$ 105°-106°.

(2) In the absence of geraniol, citronellol can be characterized by the preparation of liquid citronellyl acid phthalate which yields a crystalline silver salt $m.$ 125°-126°.

(3) In the presence of geraniol, citronellol may be characterized, according to Bouveault and Gourmand,¹⁶ by the conversion to the citronellyl ester of pyruvic acid, the semicarbazone of which melts at 110°-111°.

(4) On oxidation with chromic acid, citronellol yields citronellal, the semicarbazone of which melts at 82.5° and 84°, according to Tiemann and Schmidt.¹⁷ Or, citronellal may be converted, with β -naphthylamine and pyruvic acid, to citronellyl- β -naphthocinchonic acid m. 225°, according to Doebner.¹⁸

Properties.—Citronellol is a colorless oil possessing a typical rose-like odor. The following properties are noted in the literature:

d-Citronellol, isolated from Java citronella oil (Gildemeister and Hoffmann¹⁹):

b ₂₀	119°–121° (Doeuvre)	α_D	+2° 7' to +2° 32'
b ₇	109°	α_D^{16}	+2° 14' (Doeuvre)
b ₅	103°	n _D ²²	1.45651–1.45791
d ₄ ¹⁷	0.866 (Doeuvre)	n _D ¹⁷	1.4617 (Doeuvre)
d ₁₅ ¹⁵	0.8604–0.8629		

Prepared by reduction of citronellal (Tiemann and Schmidt²⁰):

b ₁₇	117°–118°	$[\alpha]_D^{17.5}$	+4° 0'
d _{17.5}	0.8565	n _D	1.45659

No evidence is at hand, however, to indicate the degree to which these properties represent either a homogeneous citronellol or a mixture of “ α ” or “ β ” forms. Naves, Brus and Allard²¹ employed spectroscopic methods to determine whether the various isomers occur in pure form or as mixtures.

These authors prepared four kinds of citronellol—(I) by the reduction of ethyl citronellate derived from Java citronella oil; (II) reduction of a citronellal isolated from Java citronella oil by cold tributoxy aluminum; (III) reduction of citronellal-geraniol mixtures from oil of citronella by means of a nickel catalyst; and (IV) purified “rhodinol” fraction from Réunion geranium oil by means of the benzoate. The processing of types II and III gave wholly β -citronellol with these properties:

	<i>II</i>		<i>III</i>
b ₁₁	105°–105.5°	b ₁₀	103°–104°
d ₄ ²⁰	0.8550	d ₄ ²⁰	0.8528
$[\alpha]_j$	+4° 28'	$[\alpha]_j$	+3° 27'
n _D ²⁰	1.4559	n _D ²⁰	1.4550

whereas type I and the laevorotatory IV were shown to be mixtures of α - and β - isomers with the β - form predominating:

<i>I</i>			
b ₁₀	103°–104°	$[\alpha]_j$	+5° 7'
d ₄ ²⁰	0.8551	n _D ²⁰	1.4562

l-Citronellol, isolated from Réunion geranium oil (Gildemeister and Hoffmann):

$b_{764.5}$	225°–226°	α_D	Slightly laevorotatory up to -2°
d_{15}^{15}	0.862–0.869	n_D^{20}	1.459–1.463
Sol.	Soluble in 1.5 vol. of 50%, and in 3–4 vol. of 60% alcohol		

A citronellol isolated from Réunion geranium oil by Naves, Brus and Alard,²² purified through the benzoate and shown to be a mixture of α - and β -forms, principally β -, had these properties:

b_{10}	103°–104°	$[\alpha]_j$	$-2^\circ 24'$
d_4^{20}	0.8562	n_D^{20}	1.4560

Similar findings have been reported by Dœuvre²³ on the alcohol obtained by reduction of citronellal from Bourbon geranium oil by ethoxymagnesium chloride.

Isolated from rose oil by the phosphorus trichloride process (Tiemann and Schmidt²⁴):

b_{15}	113°–114°	α_D	$-4^\circ 20'$
d_{20}	0.8612	n_D	1.45789

l-Citronellol possesses a much finer rose odor than *d*-citronellol.

Grignard and Escourrou²⁵ recorded for *dl*-citronellol:

b_{20}	116°–118°
d_{13}	0.8516
n_D^{11}	1.4516

Citronellol is much more stable than geraniol. Heating with water to 250°, boiling with alkalis, treatment with phosphorus trichloride in the cold, etc., do not affect citronellol fundamentally. A singularly interesting observation in connection with the thermal stability of citronellol is made by Bosart²⁶ in his studies on the change in specific gravity of essential oils per degree temperature. This author notes a higher value for Java citronella oil than for Ceylon oil and states that "evidently there are two forms of citronellol, one of which appears to be very unstable and is readily changed to the other form on heating. The Java oil contains the unstable one, Ceylon oil the stable form." Tiemann and Schmidt²⁷ found that oxidation with chromic acid mixture yields citronellal, isopulegol and citronellic acid. According to Labbé²⁸ citronellol dissolves in a neutral solution of sodium bisulfite, and gives a crystalline but highly hygroscopic compound $C_{10}H_{20}ONaHSO_3$. Citronellol can be mixed with 50 per cent sulfuric acid without marked change while stronger acids cause mainly polymerization. By boiling with acid anhydrides, citronellol is easily esterified. Anhydrous formic acid acts upon

citronellol even in the cold but this action is not confined to the formation of citronellyl formate. Pfau²⁹ found that considerable quantities of citronellyl glycol formates are formed as side reaction.

Müller³⁰ noted that the "EM" reagent³¹ fails with citronellol; thus it may be used to detect contaminants (such as geraniol, which gives a pronounced color reaction).

Use.—Citronellol is one of the most important aromatic isolates used widely in perfumes, cosmetics, and soaps. It is a main constituent in synthetic rose compounds. Rhodinol, too, is extensively used for the same purposes but, because of its higher price, to a more limited extent.

- ¹ *Compt. rend.* **187** (1928), 270, 330. *Bull. soc. chim.* [4], **45** (1929), 352.
- ² *Bull. soc. chim.* [4], **45** (1929), 327.
- ³ *Ibid.* [4], **45** (1929), 710. *Parfums France* **12** (1934), 197. *Bull. soc. chim.* [5], **3** (1936), 612.
- ⁴ *Ber.* **65** (1932), 1285.
- ⁵ *Compt. rend.* **198** (1934), 166.
- ⁶ *Ibid.* 2242.
- ⁷ *Ibid.* **200** (1935), 1112. *Perfumery Essential Oil Record* **37** (1946), 120.
- ⁸ *J. Chem. Soc.* (1935), 781.
- ⁹ *Ber.* **70** (1937), 37. *Chem. Zentr.* I (1937), 1964.
- ¹⁰ Vorontsov, *Bull. App. Bot. Genetics Plant Breeding U.S.S.R., Suppl.* **77** (1936), 7.
- ¹¹ *Ber.* **29** (1896), 921.
- ¹² *Ibid.*
- ¹³ *Parfums France* **8** (1930), 326.
- ¹⁴ *Ber.* **33** (1900), 2307.
- ¹⁵ *Compt. rend.* **187** (1928), 270, 330. *Bull. soc. chim.* [4], **45** (1929), 352. See also Doevre, *Compt. rend.* **208** (1939), 1658. *Bull. soc. chim.* [5], **7** (1940), 139.
- ¹⁶ *Compt. rend.* **138** (1904), 1699.
- ¹⁷ *Ber.* **30** (1897), 34; **31** (1898), 3307.
- ¹⁸ *Ibid.* **27** (1894), 354, 2026.
- ¹⁹ "Die Ätherischen Öle," 3d Ed., Vol. I, 442. See also Doevre, *Bull. soc. chim.* [4], **45** (1929), 262.
- ²⁰ *Ber.* **29** (1896), 906.
- ²¹ *Compt. rend.* **200** (1935), 1112.
- ²² *Ibid.*
- ²³ *Compt. rend.* **208** (1939), 1658.
- ²⁴ *Ber.* **29** (1896), 923.
- ²⁵ *Bull. soc. chim.* [4], **37** (1925), 547.
- ²⁶ *Perfumery Essential Oil Record* **30** (1939), 145.
- ²⁷ *Ber.* **30** (1897), 32.
- ²⁸ *Bull. soc. chim.* [3], **21** (1899), 1079. See also Dupont and Labaune, *Bull. Roure-Bertrand Fils*, April (1913), 3.
- ²⁹ *J. prakt. Chem.* [2], **102** (1921), 276.
- ³⁰ *Seifensieder-Ztg.* **68** (1941), 478. *Chem. Zentr.* II (1942), 348. *Chem. Abstracts* **37** (1943), 6410.
- ³¹ For composition of "EM" Reagent see *Deut. Parfümerieztg.* **26** (1940), 239. *Chem. Abstracts* **37** (1943), 2513.

SUGGESTED ADDITIONAL LITERATURE

A. Reclaire, *Riechstoff Ind.* (1926), 229. *Chimie & industrie* **19** (1928), 109. A review, *Chem. Abstracts* **22** (1928), 1346.

V. Grignard and J. Doevre, "Determination of the Constitution of Citronellol and

of Rhodinol by the Method of Quantitative Ozonization," *Bull. soc. chim.* [4], **45** (1929), 809. *Chem. Abstracts* **24** (1930), 1077.

Sebastian Sabetay, "Color Reaction of Geranium Oil and Certain Commercial Rhodinols," *Riechstoff Ind.* **8** (1933), 26. *Chem. Abstracts* **27** (1933), 2530.

Gustavo A. Fester, "Isomerism in the Citronellol Group," *Anales soc. cient. argentina, Sección Santá Fe* **7** (1935), 49. *Chem. Abstracts* **31** (1937), 1004.

Ignaz Herold, "Geraniol and Citronellol," *Seifensieder Ztg.* **62** (1935), 389, 409. A review, *Chem. Abstracts* **29** (1935), 5069.

Koshiro Ishimura and Kaneo Tamira, "The Catalytic Action of Reduced Nickel in the Hydrogenation of Geraniol, Citronellol, and Linaloöl," *Bull. Chem. Soc. Japan* **18** (1943), 194. *Chem. Abstracts* **41** (1947), 4445.

Y. R. Naves, "Sur l'Identification du Citronellol (Rhodinol) au Moyen de Son Allophanate," *Helv. Chim. Acta* **29** (1946), 1447.

Y. R. Naves, "Sur l'Identification de Citronellol en Presence de Geraniol et de Nerol." *Helv. Chim. Acta* **29** (1946), 1450.

B. CYCLIC TERPENE ALCOHOLS

(a) MONOCYCLIC TERPENE ALCOHOLS.

Perillyl Alcohol

$C_{10}H_{16}O$

Mol. Weight 152.23

1,8(9)-*p*-Menthadien-7-ol 4-Isopropenyl-1-cyclohexenecarbinol.

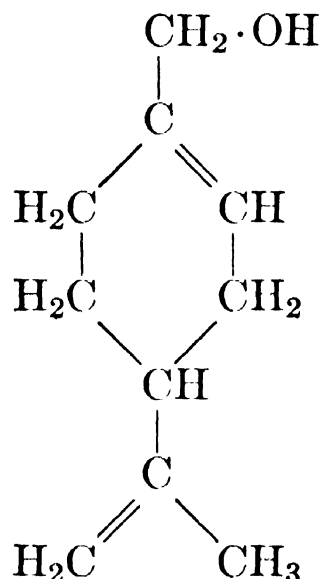

Occurrence.—This alcohol occurs, free and as ester and in both optical modifications, in oil of gingergrass (*Andropogon schoenanthus* L.). It has also been found in oil of bergamot, savin, *Monarda fistulosa*, lavandin and spearmint, in the latter mostly as ester.

Isolation.—In gingergrass oil, for example, perillyl alcohol occurs associated with geraniol from which it can be separated only with some difficulty. For this purpose the geraniol is destroyed by heating the alcohol mixture with formic acid. Thus, perillyl alcohol may be isolated from gingergrass oil, according to Schimmel & Co.,¹ by first saponifying the oil and by separating the geraniol-perillyl alcohol fraction b_{10}

106°. The geraniol is decomposed by heating the alcohol mixture on the steam bath at 80° with two parts of formic acid (99%). Saponification of the perillyl formate yields perillyl alcohol.

Identification.—Perillyl alcohol may be identified:

(1) Through its naphthylurethane m. 146°–147°.

(2) By oxidation with chromic acid to dihydrocuminic aldehyde (semicarbazone m. 198°–198.5°) and to dihydrocuminic acid m. 130°–131°, according to Semmler and Zaar.²

Properties.—Perillyl alcohol is a rather viscid oil with an odor reminiscent of linalool and terpineol. The rotatory power of perillyl alcohol shows considerable variation in different samples. Walbaum and Hüthig³ reported for perillyl alcohol isolated from gingergrass oil:

<i>d-Modification</i>		<i>l-Modification</i>	
b ₇₅₅	228°–229°	b ₇₆₇	226°–227°
b ₄₋₅	94°–96°	b ₅	92°–93.5°
d ₁₅ ¹⁵	0.9536	d ₁₅ ¹⁵	0.9510
α _D (1 = 100 mm.)	+12° 5'	α _D (1 = 100 mm.)	–13° 18'
n _D ²⁰	1.49761	n _D ²⁰	1.49629

Semmler and Zaar reported the following properties for perillyl alcohol from gingergrass oil.⁴ They also characterized a perillyl alcohol obtained by reduction of perillaldehyde,⁵ [α]_D –146° 0'.

b _{12.5}	107°–110° ⁴	[α] _D	–7° 0' ⁴
b ₁₁	119°–121° ⁵	[α] _D	–68° 30' ⁵
d ₂₀	0.946 ⁴	n _D ²⁰	1.4968 ⁴
d ₂₀	0.964 ⁵	n _D	1.4996 ⁵

These figures show no close accord with those given by Walbaum and Hüthig (see above), which fact is due very likely to the difficulties of purification.

Naves⁶ has reported the presence of *l*-perillyl alcohol in oil of lavandin, with these properties:

b _{2.8}	88°–89°	α _D	–18° 25'
d ₄ ²⁰	0.953	n _D ²⁰	1.4963

Use.—Perillyl alcohol has not found much use in the perfume or flavor industries.

¹ *Ber. Schimmel & Co.*, April (1904), 52; Oct. (1904), 41.

² *Ber.* **44** (1911), 56, 460.

³ *J. prakt. Chem.* [2], **71** (1905), 466.

⁴ *Ber.* **44** (1911), 460.

⁵ *Ber.* **44** (1911), 54.

⁶ *Helv. Chim. Acta* **28** (1945), 1224.

Dihydro- α -terpineol $C_{10}H_{20}O$

Mol. Weight 156.26

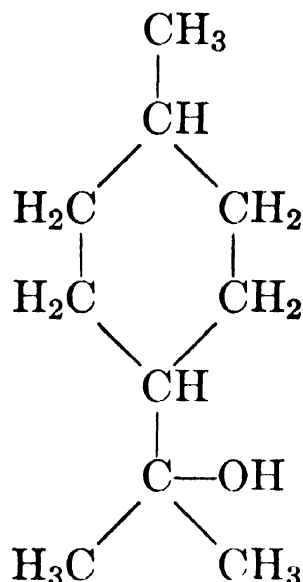
8-*p*-Menthanol

Occurrence.—Zeitschel and Schmidt ¹ found that American wood turpentine or pine oil contains the *trans*- modification of dihydro- α -terpineol.

Isolation.—Isolation is accomplished by repeated fractional distillation of pine oil, isolating the cut b. 205°–220°; treatment of this fraction with boric acid and removal of the nonesterified portion *in vacuo*; recovery of alcohols from residual borates by saponification; separation of the secondary alcohols by fractional esterification with boric acid; and final treatment of the tertiary alcohols with potassium permanganate to eliminate any contaminating terpeneol.

Identification.—By the preparation of the phenylurethane m. 117°–118°, according to Wallach,² and Zeitschel and Schmidt;³ m. 115°, according to Keats;⁴ *p*-nitrobenzoate m. 96°–97°, according to Hüchel and Nerdel.⁵

Properties.—Zeitschel and Schmidt ⁶ reported the following properties for the natural *trans*- isomer:

m.	34.6°–35.2° (in needles from petroleum ether)
b.	209.3°–209.5°
d_4^{45}	0.8962 (Keats)
d_{20}^{20}	0.901 (undercooled)
n_D^{20}	1.4630
	Flowery terpeneol odor

The *cis*- modification of dihydro- α -terpineol has been obtained synthetically by Behal,⁷ and by Zeitschel and Schmidt ⁸ but the purity of these products is questioned by Keats ⁹ who reports the synthesis of *cis*-8-hydroxy-*p*-

menthane from the ethyl ester of low melting hexahydrotoluic acid; it has these properties:

m.	25°
b ₃₀	110°
d ₄ ⁴⁵	0.9025
Phenylurethane	m. 114°
Odor similar but more faint than <i>trans</i> -form	

Use.—Dihydro- α -terpineol is not used in our industries.

¹ *Ber.* **60** (1927), 1372.

² *Liebigs Ann.* **381** (1911), 55.

³ *Ber.* **60** (1927), 1372.

⁴ *J. Chem. Soc.* (1937), 2003.

⁵ *Liebigs Ann.* **528** (1937), 57.

⁶ *Ber.* **60** (1927), 1372.

⁷ *Compt. rend.* **150** (1910), 1762.

⁸ *Ber.* **60** (1927), 1372.

⁹ *J. Chem. Soc.* (1937), 2003.

The Terpeneols

C₁₀H₁₈O

Mol. Weight 154.24

When the glycol terpin or its hydrate is dehydrated—for instance, with dilute sulfuric acid—four isomeric unsaturated alcohols C₁₀H₁₈O may be theoretically formed. Of these four isomers, only three are known—namely, α -, β -, and γ -terpineol.

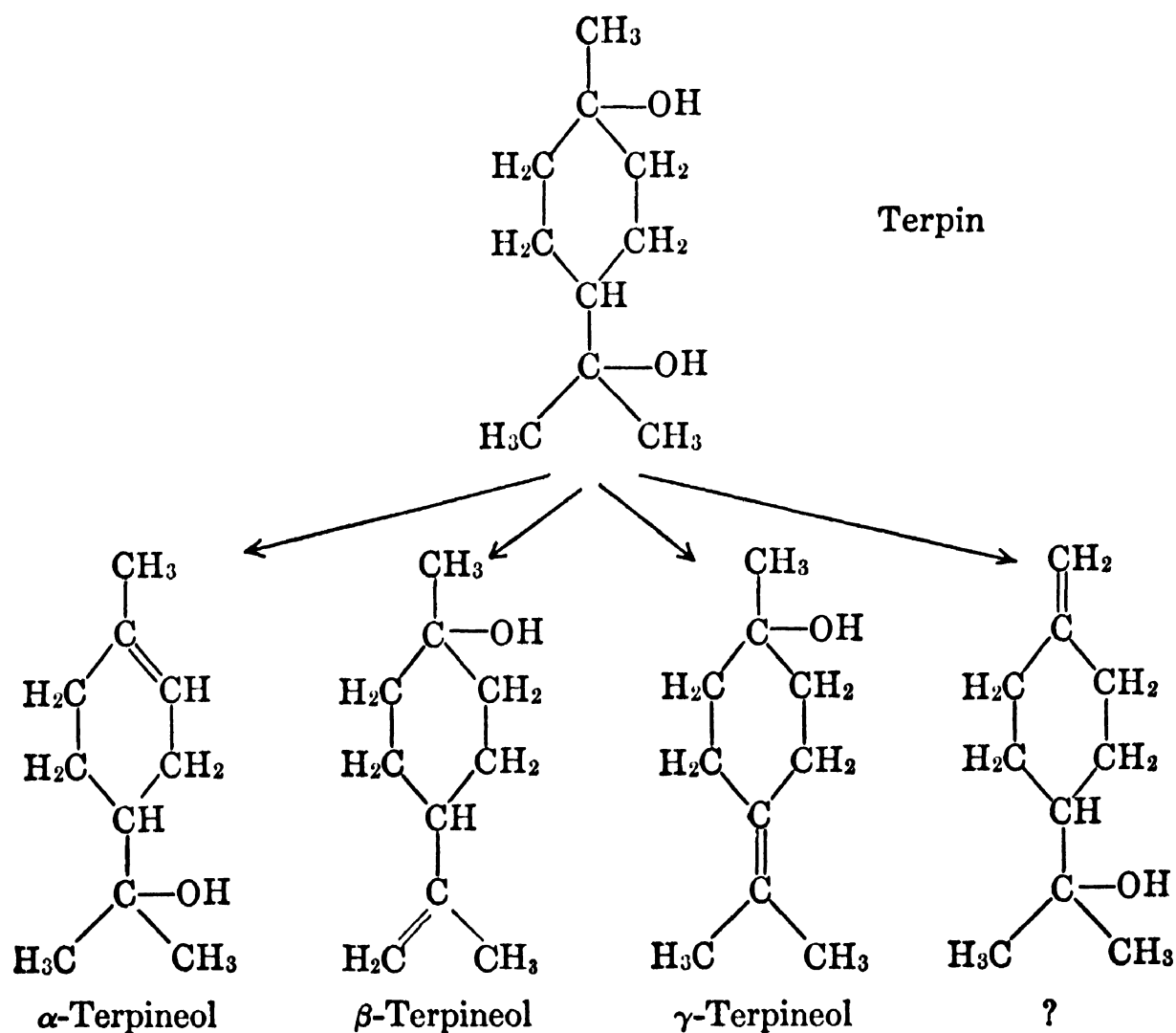

The liquid terpeneol of commerce, obtained from pine oil by various processes,¹ is not uniform but a mixture of several isomeric unsaturated tertiary alcohols, viz., α -terpineol m. 35°, β -terpineol m. 32°, and of liquid terpinen-1-ol.

¹ Among many patents, see U. S. Patent No. 1,743,403, Jan. 14, 1930, L. T. Smith to Hercules Powder Co.

α -Terpineol

$C_{10}H_{18}O$

Mol. Weight 154.24

1-*p*-Menthen-8-ol. 1-Methyl-4-isopropyl-1-cyclohexen-8-ol

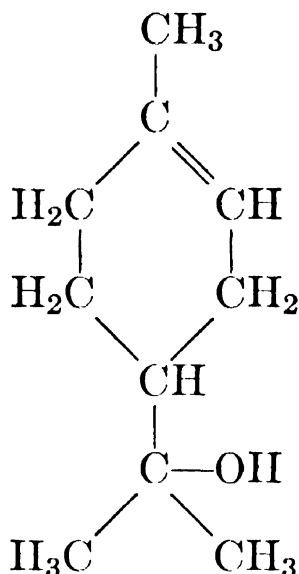

Occurrence.— α -Terpineol is the only one of the terpeneol isomers found in nature.

α -Terpineol occurs in volatile oils in optically active (*d*- and *l*-), and inactive (*dl*-), modifications, free as well as in ester form. Crystalline α -terpineol has been identified in numerous oils:

d- α -Terpineol in oil of Russian turpentine, Malabar cardamom, sweet orange, petitgrain, neroli, lovage, in laevorotatory Mexican linaloe oil, etc.

l- α -Terpineol in several pine oils, in oil of camphor, Oregon balsam, cinnamon leaves, lemon, lime, niaouli, in dextrorotatory Mexican linaloe oil, etc.

dl- α -Terpineol in oil of geranium, cajuput, etc.

Liquid α -terpineol, too, has been isolated, for example:

d- α -Terpineol from marjoram oil

l- α -Terpineol from Canadian snakeroot oil

dl- α -Terpineol from oil of mace, erigeron, etc.

Isolation.—Crystalline terpeneol can be isolated from an oil by fractional distillation. For this purpose the fractions boiling from 215° to 220° at atmospheric pressure are cooled, and inoculated with a terpeneol crystal. Terpeneol may be separated from other alcohols and isolated according to the method of Zeitschel.¹ The alcohol mixture is treated with boroacetic acid anhydride and the alcohols are regenerated by saponifi-

cation of the borates. Since the primary alcohols react quicker with this acid anhydride than the secondary ones, and the secondary alcohols quicker than the tertiary ones, the alcohols may thus be separated from one another.

Identification.— α -Terpineol can be characterized by the preparation of several compounds:

(1) By the nitrosochlorides.

For their preparation, Wallach² recommended adding 11 cc. of ethyl nitrite to a solution of 15 g. of terpineol in 15 cc. of glacial acetic acid. After cooling in a salt brine mixture, a solution of 6 cc. of hydrochloric acid in 6 cc. of glacial acetic acid is added drop by drop and with shaking. After completion of the reaction, the nitrosochloride is precipitated with ice water, whereby the nitrosochloride separates first in oily form but crystallizes soon. The solid product can be purified by recrystallization from hot ethyl acetate or methyl alcohol. The *d*- or *l*- form melts at 107°–108°, the *dl*- form at 120°–122°.

(2) More characteristic derivatives for the identification of α -terpineol are the nitrolpiperidines as prepared from the crystalline nitrosochlorides.

The inactive (*dl*-) form melts at 159°–160°, the active (*d*- and *l*-) form at 151°–152°. Wallach³ also suggested the nitrolaniline m. 155°–156° for the identification of α -terpineol.

(3) Provided no linaloöl is present, α -terpineol may be characterized by the preparation of its phenylurethane.

According to Wallach,⁴ the hydroxy group of terpineol reacts with phenylisocyanate when both compounds are mixed and permitted to react at room temperature for some time. Occasionally crystals of diphenylurea (carbanilide) m. 236° separate at first, from which the liquid mixture is separated by extraction with cold anhydrous ether or, better, with low boiling petroleum ether. After careful evaporation of the solvent, the diphenylurethane separates in fine needles. Recrystallized from alcohol, the inactive compound melts at 113°. The diphenylurethane obtained from optically active terpineol is also active; it melts at 109.5°.

Schimmel & Co.⁵ recommended the α -naphthylurethane compound m. 147°–148° for the identification of α -terpineol. Neuberg and Hirschberg⁶ reported m. 151°–152°.

(4) According to Gildemeister and Hoffmann,⁷ α -terpineol can be characterized, provided no linaloöl is present, by converting it into terpin hydrate m. 116°–117°. This may be accomplished simply by shaking α -terpineol for several days with dilute (5%) sulfuric acid. In case linaloöl is present, the mixture is carefully heated with strong formic acid which decomposes mostly linaloöl.

(5) The same authors suggested a method of identifying α -terpineol in mixtures with other alcohols. By benzoylating in the presence of pyridene, terpineol can be separated from the other alcohols. Only primary and secondary alcohols react with the benzoyl group, whereas tertiary alcohols like terpineol and linaloöl do not react, and may be separated by steam distillation from the high boiling, mostly nonvolatile benzoates of the other alcohols. One and one-half parts of benzoylchloride are carefully added, drop by drop, and at low temperature (freezing mixture) to 1 part of alcohol fraction dissolved in 3 parts of pyridene. The excess benzoylchloride is decomposed with water, also at low temperature.

(6) According to Wallach,⁸ α -terpineol can be characterized by the preparation of its dihydroiodide (dipentene dihydroiodide) m. 77°–78°, which is obtained by shaking α -terpineol with concentrated hydriodic acid.

(7) According to Naves and Grampoloff,⁹ the allophanate of α -terpineol, $C_{12}H_{20}N_2O_3$, m. 133°–134°, may be used to characterize this terpene alcohol.

Regarding the quantitative determination of α -terpineol, see Vol. I, Chapter 4, "The Examination and Analysis of Essential Oils, Synthetics, and Isolates," p. 276.

Properties.—The properties of the natural crystalline α -terpineol reported in literature, especially the rotatory powers, vary within rather wide limits, which may be due in part to the large potential number of isomers of this compound.

d- α -Terpineol was derived from sweet orange oil by Stephan,¹⁰ from oil of neroli bigarade by Hesse and Zeitschel,¹¹ and from turpentine oil by Flavitski:¹²

m.	38°–40° ¹⁰	$[\alpha]_D$	+95° 9' ¹⁰
b.	219°–221° ¹⁰	$[\alpha]_D$	+31° 30' ¹¹
b ₂₅	115°–116° ¹¹	$[\alpha]_D^{19.5}$	+48° 24' ¹²
d ₄ ^{19.5}	0.9189 ¹²	n _D ¹⁸	1.48322 ¹⁰
d ₄ ⁰	0.9335 ¹²		

l- α -Terpineol, from linaloe oil, as recorded by Schimmel & Co.,¹³ and from pinene hydrate by Wallach:¹⁴

m.	37°–38° ¹⁴	$[\alpha]_D^{16}$	–106° ¹⁴ (in ether $p = 16.34$)
b.	219°–221° ¹³	$[\alpha]_D$	–27° 20' ¹³
b ₃₋₄	85° ¹³	n _D ²⁰	1.48131 ¹³

Crystalline dl- α -terpineol possesses the characteristic lilac odor of the liquid modification only to a small degree. Wallach,¹⁵ Stephan and Helle,¹⁶ Gilde-meister and Hoffmann,¹⁷ and Kay and Perkin¹⁸ reported the following properties:

m.	35°–36° ^{15, 16}	d ₄₅ ⁴⁵	0.9256 ¹⁸ (fused)
b ₇₅₂	218.8°–219.4° ¹⁶	d ₄₀ ⁴⁰	0.9282 ¹⁸ (fused)
b ₂₅	120°–122° ¹⁸	d ₂₅ ²⁵	0.9355 ¹⁸ (surfused)
b ₁₀	98°–99° ¹⁶	d ₂₀ ²⁰	0.935 ¹⁶
b ₃	85° ¹⁷	d ₁₅ ¹⁵	0.939 ¹⁶
		d ₁₅ ¹⁵	0.9415 ¹⁸ (surfused)
		n _D ²⁰	1.48268 ¹⁷

The synthetic (liquid) terpineol of commerce consists mainly of α -terpineol, some β -terpineol and terpinen-1-ol. According to the "Specifications and Standards" of the Essential Oil Association of the United States,¹⁹ the physico-chemical properties of commercial terpineol vary between these limits:

b.	214°–224°, 90% distill within 5°	α_D	–0° 10' to +0° 10'
d ₁₅	0.936–0.941	n _D ²⁰	1.4825–1.4850

- Cong. pt. All products should crystallize when seeded at $+2^{\circ}$
- Sol. Soluble in 2 and more vol. of 70% alcohol, in 4 and more vol. of 60% alcohol, in 8 and more vol. of 50% alcohol
- Water dissolves approximately 0.5% terpineol
- Terpineol dissolves approximately 5% water. (Terpineol is clearly miscible with any volume of petroleum ether, which means that the product contains less than 1% of water.—The Authors.)

The optically active as well as the inactive modification of α -terpineol gives the same chemical reactions, and the melting points of some of the derivatives are not markedly different:

	<i>Inactive</i> <i>Form</i>	<i>Active</i> <i>Form</i>
Melting point	35°	$37^{\circ}-38^{\circ}$
Nitrosochloride	$112^{\circ}-113^{\circ}$	$107^{\circ}-108^{\circ}$
Nitrolpiperidine	$159^{\circ}-160^{\circ}$	$151^{\circ}-152^{\circ}$

Being a tertiary, unsaturated cyclic terpene alcohol, α -terpineol forms addition compounds with bromine, nitrogen tetroxide and nitrosylchloride, some of which compounds may prove useful in connection with the identification of α -terpineol.

The liquid dibromide, on treatment with hydrogen bromide-glacial acetic acid, yields an oily tribromide and, on further bromination, dipentene tetrabromide m. 124° .

Under the influence of inorganic and organic acids, especially on warming, α -terpineol is quite unstable, dehydration producing a mixture of hydrocarbons.²⁰ With potassium bisulfate, for example, the main product will be dipentene; with formic acid and aqueous oxalic acid, chiefly terpinolene; with phosphoric acid, mainly terpinolene, also some terpinene and cineole. In fact, considerable quantities of terpinene are formed in every case. When boiling α -terpineol with dilute sulfuric acid, the products of dehydration will be terpinene, and some dipentene and cineole. Dipentene is formed also by the action of acetic acid anhydride, especially on heating. Thus, terpineol cannot be esterified quantitatively without special precautions which must be considered in the analytical assaying of terpineol (see Vol. I, Chapter 4, "The Examination and Analysis of Essential Oils, Synthetics, and Isolates"). The esters may be prepared in good yield by starting from the potassium salts of the acids. Thus, Fuller and Kenyon²¹ prepared *dl*- α -terpinyl acid phthalate m. $117^{\circ}-118^{\circ}$.

When shaken with dilute mineral acids, α -terpineol, according to Aschan,²² is hydrated to terpin, the reaction proceeding quantitatively with sulfuric acid (40 per cent) at 0° .

Wallach,²³ and Tiemann and Semmler²⁴ found that, with dilute potassium permanganate solution, terpineol is first oxidized to *p*-menthane-1,2,8-triol, inactive compound m. 121°–122°.

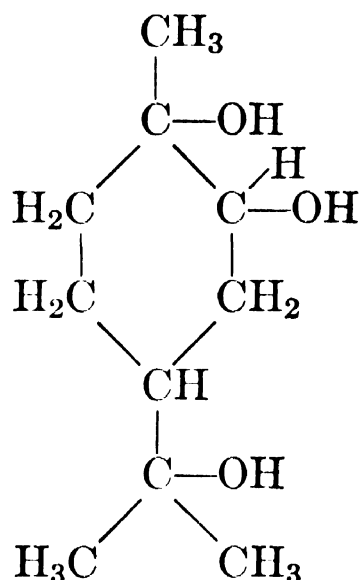

On treatment with chromic acid mixture, this glycerol $\text{C}_{10}\text{H}_{20}\text{O}_3$ is oxidized to a ketonic lactone $\text{C}_{10}\text{H}_{16}\text{O}_3$, viz., homoterpenyl methyl ketone. The melting point of the optically active compound is 46°–47°, that of the inactive compound 64°. This ketone can be characterized by the preparation of its oxime m. 80°–81°, and its semicarbazone m. 200°.

Use.—Terpineol is one of the most important compounds used in the perfume, cosmetic, and soap industries. Because of its typical lilac odor and the low price of the synthetic product, terpineol is widely used in many preparations.

¹ German Patent No. 444,640 (1924), A. Deppe Söhne.

² *Liebigs Ann.* **277** (1893), 120; **360** (1908), 90 Cf. Simonsen, "The Terpenes," Vol. II (1932), 231.

³ *Liebigs Ann.* **360** (1900), 90.

⁴ *Ibid.* **230** (1885), 268; **275** (1893), 104.

⁵ *Ber. Schimmel & Co.*, Oct. (1906), 33.

⁶ *Biochem. Z.* **27** (1910), 345.

⁷ "Die Ätherischen Öle," 3d Ed., Vol. I (1928), 460. Cf. Deninger, *Ber.* **28** (1895), 1322.

⁸ *Liebigs Ann.* **230** (1885), 265.

⁹ *Helv. Chim. Acta* **25** (1942), 1503.

¹⁰ *J. prakt. Chem.* [2], **62** (1900), 530.

¹¹ *Ibid.* [2], **66** (1902), 497.

¹² *Ber.* **20** (1887), 1958.

¹³ *Ber. Schimmel & Co.*, Oct. (1905), 46.

¹⁴ *Liebigs Ann.* **360** (1908), 89.

¹⁵ *Ibid.* **275** (1893), 104.

¹⁶ *Ber.* **35** (1902), 2149.

¹⁷ "Die Ätherischen Öle," 3d Ed., Vol. I, 455.

¹⁸ *J. Chem. Soc.* **89** (1906), 851.

¹⁹ January 10, 1947.

²⁰ Among many papers on this subject, see Dupont, Lévy and Marot, *Bull. soc. chim.* [4], **53** (1933), 393.

²¹ *J. Chem. Soc.* **125** (1924), 2309.

²² *Bidrag til Kännedom af Finnland* **77** (1918), 30. *Chem. Abstracts* **13** (1919), 2759.

²³ *Ber.* **28** (1895), 1775. *Liebigs Ann.* **275** (1893), 150; **277** (1893), 110.

²⁴ *Ber.* **28** (1895), 1778.

SUGGESTED ADDITIONAL LITERATURE

Tessaku Ikeda and Shosaburo Takeda, "A New Method for the Determination of Linalool, Cineole and Terpeneol," *J. Chem. Soc. Japan* **57** (1936), 442. *Chem. Abstracts* **30** (1936), 5907.

V. I. Varentsev, "Determination of Terpeneol in Aqueous Solutions by the Surface-Tension Method," *J. Applied Chem. (U.S.S.R.)* **11** (1938), 142 (in German 145). *Chem. Abstracts* **32** (1938), 4471.

β-TerpeneolC₁₀H₁₈O

Mol. Weight 154.24

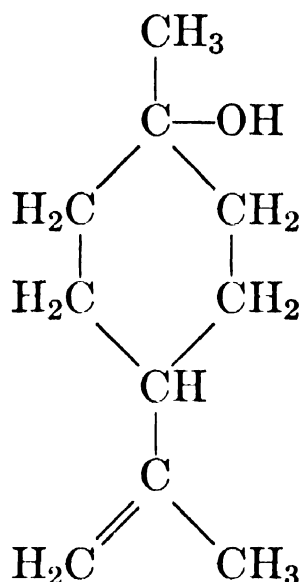
8(9)-*p*-Menthen-1-ol. 1-Methyl-4-isopropenylcyclohexan-1-ol

Occurrence.—This tertiary, unsaturated terpene alcohol has not been found in nature.

Isolation.—*β*-Terpeneol may be prepared by cooling the fraction b. 212°–215° of commercial (liquid) terpeneol to a low temperature.

Identification.—*β*-Terpeneol has been identified by Stephan and Helle,¹ and Wallach and Schmitz² by means of the following derivatives:

(1) Nitrosochloride	m. 103°
(2) Nitrolpiperidine	m. 108°
(3) Nitrolaniline	m. 110°
(4) Phenylurethane	m. 85°
(5) Nitrosate	m. 125°
(6) Nitrosite	m. 78°

The nitrosochloride does not react very easily with bases; the most satisfactory derivative is the nitrolaniline.

Properties.—Optically inactive β -terpineol, isolated from commercial (liquid) terpineol, possesses an odor reminiscent of hyacinth. Stephan and Helle ³ and Eijkman ⁴ reported these typical properties:

m.	32°–33° ³	α_D	$\pm 0^\circ$ ³
b ₇₅₂	209°–210° ³	n _D ²⁰ (superfused)	1.4747 ³
b ₁₀	90° ³		
d _{79.8}	0.8703 ⁴		
d ₂₀ ²⁰ (superfused)	0.919 ³		
d ₁₅ ¹⁵ (superfused)	0.923 ³		

Theoretically, β -terpineol should exist in *cis*- and *trans*- modification, but only one form is known.

By hydration with dilute sulfuric acid, β -terpineol yields terpin hydrate, according to Wallach,⁵ but much more rapidly than α -terpineol.

Stephan and Helle,⁶ and Wallach⁷ found that, on oxidation with dilute potassium permanganate, β -terpineol gives as a primary product a crystalline glycerol, viz., *p*-menthane-1,8,9-triol, m. 118°–118.5° which, on further oxidation with chromic acid, yields a hydroxy-ketone b₁₉ 140°–145° (semicarbazone m. 195°–196°), together with an unsaturated ketone b₄ 68.5°–70° (semicarbazone m. 160°).

Use.—As a constituent of commercial (liquid) terpineol, β -terpineol is very widely used (see " α -Terpineol").

¹ *Ber.* **35** (1902), 2148.

² *Liebigs Ann.* **345** (1906), 128. Cf. Wallach, "Terpene und Campher," 2d Ed. (1914), 305.

³ *Ber.* **35** (1902), 2148.

⁴ *Chem. Weekblad* **8** (1911), 673.

⁵ *Liebigs Ann.* **360** (1908), 101.

⁶ *Ber.* **35** (1902), 2149.

⁷ *Liebigs Ann.* **324** (1902), 87; **381** (1911), 90. Perkin and Wallach, *ibid.* **374** (1910), 206.

γ -Terpineol $C_{10}H_{18}O$

Mol. Weight 154.24

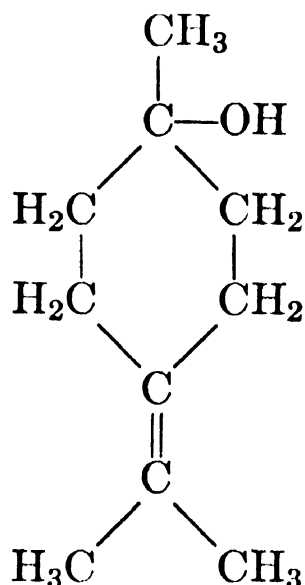
4(8)-*p*-Menthen-1-ol. 1-Methyl-4-isopropylidenecyclohexan-1-ol

Occurrence.—Whether this unsaturated, tertiary, cyclic terpene alcohol occurs in nature has not yet been definitely proved. According to Simonsen,¹ small quantities are probably present in the oil distilled from *Cupressus torulosa* Don.

Identification.—(1) The same author expressed the opinion that the most satisfactory derivative for characterization is apparently the dibromide m. 114°–115°.

(2) γ -Terpineol may also be identified by the preparation of its acetate, whose blue monomolecular nitrosochloride melts at 81°–82° (Baeyer and Blau²).

(3) Wallach³ found that, with dilute (1%) sulfuric acid, γ -terpineol can be hydrated most readily to a mixture of *cis*- and *trans*-terpins. On dehydration with formic acid, terpinolene is obtained.

(4) When oxidized with dilute potassium permanganate solution, this alcohol yields a glycerol, viz., *p*-menthane-1,4,8-triol, m. 110°–112° which, by the action of hydrogen bromide, gives a tribromide.

Properties.— γ -Terpineol, like α -terpineol, possesses a lilac-like odor. Simonsen⁴ and Eijkman⁵ observed the following characteristics:

m.	68°–70° ⁴	n_D^{80}	1.4628 ⁵
d_{80}	0.8948 ⁵	n_D^{80}	1.4730 ⁵

The acetate of γ -terpineol boils from 110°–120° at 16 mm.

Use.—This terpene alcohol is not readily available; hence γ -terpineol has not found any practical employment.

¹ *Indian Forest Records* 10 (1923), 1. Cf. "The Terpenes," Vol. I (1947), 271.

² *Ber.* 28 (1895), 2292.

³ *Ber.* 40 (1907), 578.

⁴ "The Terpenes," Vol. I (1947), 272.

⁵ *Chem. Weekblad* 8 (1911), 673.

The Terpinenols



Mol. Weight 154.24

The unsaturated, cyclic, tertiary terpene alcohols $C_{10}H_{18}O$, to which the name terpinenols has been assigned, result from the cleavage of one mol of water from terpinene-terpin (1,4-terpin), whereby four isomeric alcohols are theoretically obtained. Thus, these four alcohols bear the same relationship to terpinene-terpin as do the terpeneols to terpin. Only one of the four isomers, viz., terpinen-4-ol, has been found in nature, while terpinen-1-ol occurs in commercial (liquid) terpineol.

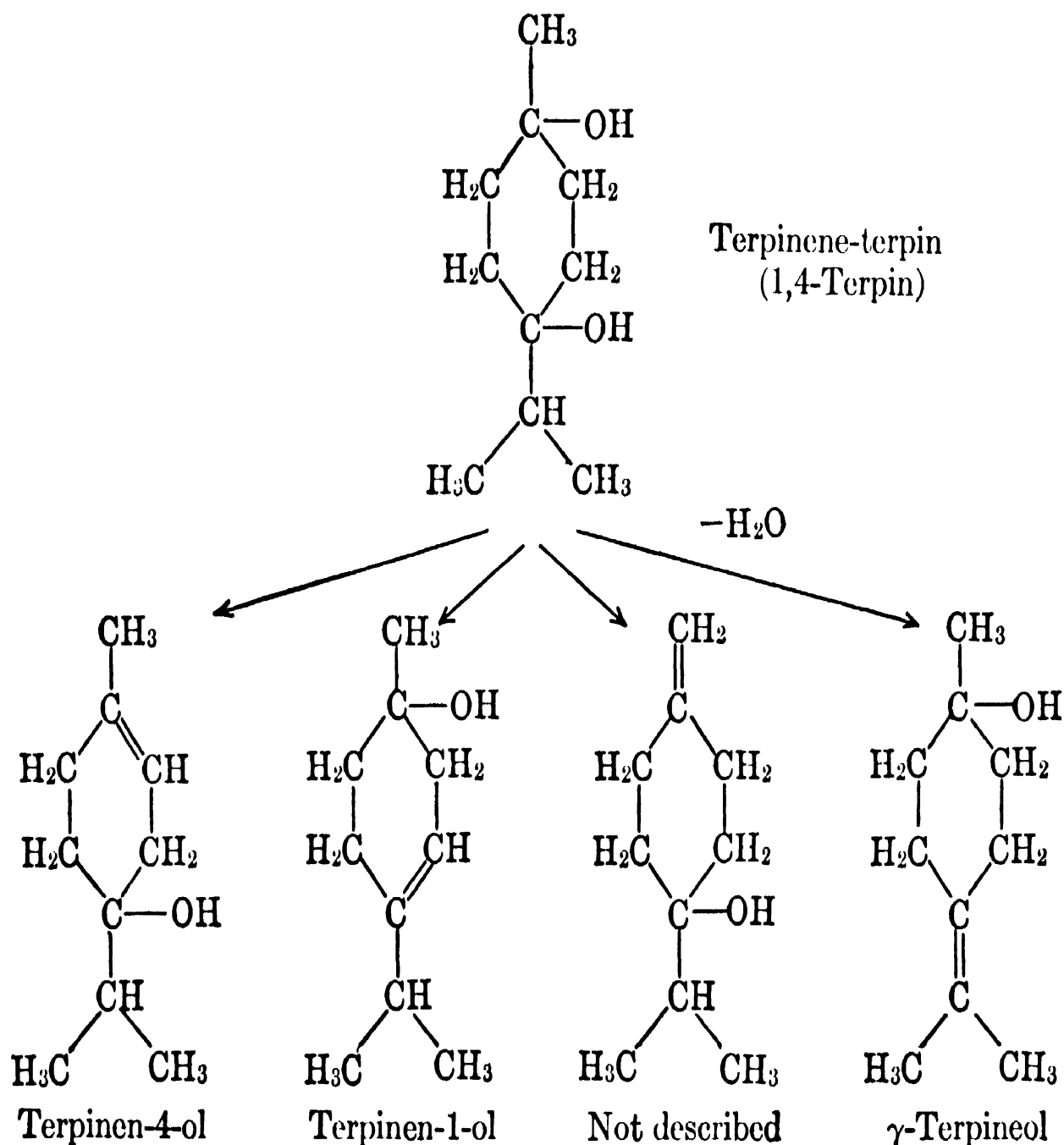

*Terpinen-1-ol*C₁₀H₁₈O

Mol. Weight 154.24

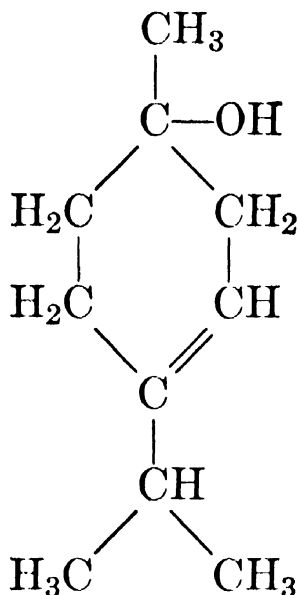
3-*p*-Menthen-1-ol. 1-Methyl-4-isopropyl-3-cyclohexen-1-ol. Terpinenol-(1)

Occurrence.—This tertiary, unsaturated, cyclic terpene alcohol has not been found in nature. Wallach¹ isolated it from the low boiling fraction of commercial (liquid) terpeneol.

Identification.—(1) With hydrogen chloride in acetic acid solution, terpinen-1-ol yields terpinene dihydrochloride m. 51°–52°.

(2) Terpinen-1-ol may also be characterized by its products of oxidation (see below).

Properties.—Terpinen-1-ol is a liquid that does not crystallize at low temperature. Wallach and Meister² reported for the synthetic product these typical properties:

b.	208°–210°
d ₁₈	0.9265
n _D ¹⁸	1.4781

On oxidation with cold dilute potassium permanganate, terpinen-1-ol yields a glycerol, viz., *p*-menthane-1,3,4-triol m. 120°–121° which, on further oxidation, gives α,δ-dihydroxy-α-methyl-δ-isopropyladipic acid. When heated with dilute mineral acids, the glycerol is converted into a mixture of *p*-cymene and *dl*-piperitone (1-menthen-3-one). This ketone may be identified by the preparation of its semicarbazone m. 224°–225°.

Use.—Being a constituent of commercial (liquid) terpeneol, terpinen-1-ol is used widely (see “α-Terpeneol”).

¹ *Liebigs Ann.* **356** (1907), 218; **362** (1908), 269.

² *Ibid.* **356** (1907), 218.

*Terpinen-4-ol*C₁₀H₁₈O

Mol. Weight 154.24

1-*p*-Menthen-4-ol. 1-Methyl-4-isopropyl-1-cyclohexen-4-ol. Terpinenol-(4).
"Origanol"

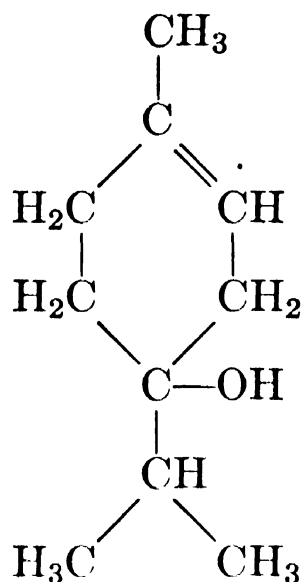

Occurrence.—This tertiary, unsaturated terpene alcohol occurs in oil of cypress, juniper berry, Ceylon cardamom, nutmeg, marjoram, thyme, and a few others. The *dl*-form has been reported by Kafuku, Nonoe and Hata¹ in the volatile oil of *Liquidambar formosana*.

Isolation.—The separation of pure terpinen-4-ol from essential oils is difficult because this alcohol does not yield any crystalline derivatives from which it could be recovered. The only method of isolating terpinen-4-ol is, therefore, by fractional distillation.

Identification.—According to Nagai,² active terpinen-4-ol may be identified by the preparation of several derivatives:

(1) Nitrosochloride	m. 111°–112°
(2) Nitropiperidine	m. 172°–174°
(3) Phenylurethane	m. 71°–72°
(4) α -Naphthylurethane	m. 105.5°–106.5°

Briggs and Sutherland³ prepared a naphthylurethane m. 107°–108°. Penfold⁴ obtained a highly characteristic naphthylurethane m. 104°–105°, and a crystalline nitrosochloride m. 115°–116°.

Simonsen,⁵ however, maintains that terpinen-4-ol is difficult to identify and probably may be characterized most readily by oxidation to the glycerol (described below), and by its conversion into terpinene dihydrochloride on treatment with hydrogen chloride. According to the same author, terpinen-4-ol does not yield a phenylurethane, the alcohol being dehydrated by the action of phenyl isocyanate with the formation of a hydrocarbon, which seems to be α -terpinene.

Hancox and Jones⁶ prepared a new derivative of this terpene alcohol: the gases generated by adding a saturated sodium nitrite solution dropwise to concentrated hydrochloric acid are passed through a solution of 4-terpinenol in dry ether cooled in a freezing mixture. The terpinenol solution rapidly becomes green and deposits a

copious precipitate which, after filtration and repeated washing with ether, yields a complex of the formula $C_{10}H_{18}N_2O_3Cl$, m. $105^\circ-106^\circ$.

Kafuku, Nonoe and Hata,⁷ prepared a nitropiperidine from the *dl*-terpene alcohol isolated from *Liquidambar formosana*. By recrystallization from alcohol this nitropiperidine was found to be a mixture of α - and β - forms: pure α - form m. $155^\circ-156^\circ$, pure β - form m. $181^\circ-182^\circ$.

Properties.—Terpinen-4-ol possesses a less agreeable odor than terpineol. It is known only in liquid form, remaining liquid even at low temperature.

Wallach,⁸ Simonsen,⁹ and Briggs and Sutherland¹⁰ reported the following properties of the *d*- form:

b.	$209^\circ-212^\circ$ ⁸	α_D	$+25^\circ 12'$ ⁹
b_{10}	$86^\circ-87^\circ$ ¹⁰	$[\alpha]_D^{25}$	$+21^\circ 22'$ ¹⁰
d_4^{25}	0.9285 ¹⁰	n_D^{25}	1.4765 ¹⁰
d^{19}	0.9265 ⁹	n_D^{19}	1.4785 ⁸

Wallach¹¹ and Semmler¹² also described the synthetically prepared *dl*-form:

b.	$212^\circ-214^\circ$ ¹¹	d_{20}	0.926 ¹²
b_{11}	$93^\circ-96^\circ$ ¹²	α_D	$\pm 0^\circ$ ¹¹
		n_D	1.48033 ¹²

Oxidation of terpinen-4-ol with dilute potassium permanganate solution yields a glycerol, viz., *p*-menthane-1,2,4-triol, m. $128^\circ-129^\circ$, which, on warming with dilute hydrochloric acid, gives carvenone. By further oxidation the glycerol is converted into α,δ -dihydroxy- α -methyl- δ -isopropyladipic acid.

Use.—Except as a constituent of commercial (liquid) terpineol, terpinen-4-ol has not found any noteworthy use in the perfume or flavor industries.

¹ *J. Chem. Soc. Japan* **55** (1934), 244. *Chem. Abstracts* **28** (1934), 3524.

² Investigations of the Shô-Gyû and Yu-Ju oils produced in Formosa, Monopoly Bureau, Government Formosa, Taihoku (1914). *Ber. Schimmel & Co.*, Oct. (1914) to April (1915), 43.

³ *J. Org. Chem.* **7** (1942), 397.

⁴ *J. Proc. Roy. Soc. N. S. Wales* **59** (1925), 313.

⁵ "The Terpenes," Vol. I (1947), 278.

⁶ *Proc. Roy. Soc. Queensland* **50** (1938), 40.

⁷ *J. Chem. Soc. Japan* **55** (1934), 244. *Chem. Abstracts* **28** (1934), 3524.

⁸ *Liebigs Ann.* **356** (1907), 215.

⁹ "The Terpenes," Vol. I (1947), 278.

¹⁰ *J. Org. Chem.* **7** (1942), 403.

¹¹ *Liebigs Ann.* **350** (1906), 155.

¹² *Ber.* **39** (1906), 4421.

The Terpins

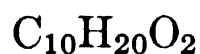

Mol. Weight 172.26

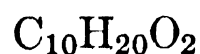
Terpin

Mol. Weight 172.26

p-Menthane-1,8-diol. 1-Methyl-4-isopropylcyclohexane-1,8-diol.
1,8-Terpin.

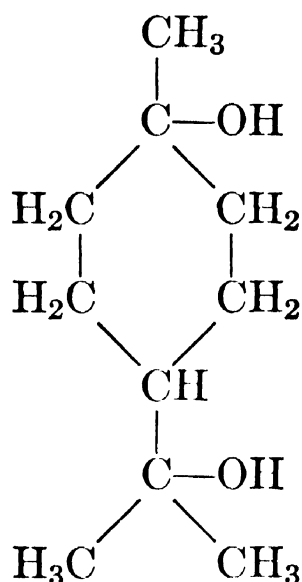

Occurrence.—Opinions vary among writers (cf. Semmler,¹ Simonsen,² Kar-
rer³ and Francesconi⁴) as to whether this glycol—which is so important in
the elucidation of the constitution of certain terpenes and in the manufactur-
ing of terpineol—occurs as such in nature, or results from secondary reactions.
However, its presence has been reported in some essential oils in the past,
and again quite recently by Machado⁵ in the oil of *Myrocarpus sylvestris* to
the extent of 65.8 per cent.

Isolation.—1,8-Terpin exists in both the *cis*- and *trans*- modifications. The *cis*-isomer
is easily obtained in the hydrated form, viz., *cis*-terpin hydrate. The *trans*-terpin does
not form a hydrate. Terpin forms quite readily if oil of turpentine is kept in contact
with water which contains acids, for crystals of terpin hydrate are deposited. *cis*-
Terpin (hydrate) can be obtained most readily by the hydration of pinene. For this
purpose, 1 part of turpentine oil is thoroughly shaken, for 90 hr., with 2 parts of 25%
sulfuric acid in an atmosphere of nitrogen or carbon dioxide. According to Marchand,⁶
the yield of crystalline terpin hydrate will then be almost quantitative. Publications,
including several patents, give evidence that the hydration of pinene is readily effected
with other reagents.⁷ Terpin can also be obtained by the cyclization of geraniol,
linaloöl, and nerol.

Identification.—The terpins may be recognized by means of their halogen acid
derivatives which exist in the corresponding *cis*- and *trans*- form; they are synonymous
with dipentene *bis*-hydrohalides:

	M. °C.	
	<i>cis</i>	<i>trans</i>
Dipentene <i>bis</i> -hydrochloride	≈ 25 ⁹	50 ⁸
Dipentene <i>bis</i> -hydrobromide	38–40 ⁹	64 ^{10,11}

Several methods of isolating and estimating this substance in drugs are available (cf. Official and Tentative Methods of Analysis A.O.A.C., 5th Ed., 1940). Numerous color reactions exist for the identification of terpin hydrate (cf. Petenkoefer Reaction,¹² vanillin hydrochloride test,¹³ *p*-dimethylaminobenzaldehyde reaction,¹⁴ and phosphomolybdic acid test¹⁵).

Properties.—*cis*-Terpin hydrate crystallizes from water in rhombic pyramids m. 116°–117°, according to Wallach.¹⁶ However, Perkin¹⁷ observed higher melting points (120°–121° decomp.) as the result of temperature measurements of “instantaneous melts”; Schoorl¹⁸ reported this melting point as 123°. The latter author also observed the eutectic mixture of the hydrate-anhydrous terpin with 10 per cent of the hydrate as m. 95°. This divergence of melting point serves to illustrate the extent to which that constant is influenced by the presence of water. The effect of pressure on the anhydrous product is substantial, as Sollazzo¹⁹ observed m. 89° at 2000 meters, vs. 104°–106° at sea level. When heated, loss of water takes place, with formation of *cis*-terpin m. 104°–105°, b. 258° (corr.), according to Wallach,²⁰ Perkin²¹ and the U. S. Dispensatory.²² On exposure to the air, the anhydrous *cis*-terpin absorbs water and *cis*-terpin hydrate is reformed.

trans-Terpin crystallizes in monoclinic prisms m. 156°–158° (Baeyer²³). As has been pointed out, the *trans*-modification does not form a hydrate.

Otherwise, the two isomers show little difference in their properties. None is easily oxidized—not with potassium permanganate at room temperature, for example. However, when heated with potassium permanganate solution, complete degradation to oxalic and acetic acids takes place.

The action of dehydrating agents results in the formation of terpineols, and several hydrocarbons, especially dipentene.

Use.—Terpin hydrate forms an important intermediary product in the manufacture of commercial terpineol. Moreover, terpin hydrate is widely employed in pharmaceutical preparations. However, it is not regarded with complete favor in the U. S. Dispensatory.

¹ “Die Ätherischen Öle,” Vol. III (1906), 64.

² “The Terpenes,” Vol. I (1947), 300.

³ “Organic Chemistry” Trans. by Mee (1938), 628.

⁴ *Profumi italici* **3** (1925), 195. *Chimie & industrie* **16** (1925), 971.

⁵ *Rev. quim. ind.* (Rio de Janeiro) **10**, No. 112, 14 (1941), 266. *Chem. Abstracts* **36** (1942), 1441.

⁶ British Patent No. 153,606.

⁷ In this connection see: (a) Paris, *Acta Commentationes Univ. Tartu* (Dorpat A16, No. 1, **3** (1930)). (b) Shumeiks, *Zhur. Prikladnoĭ Khim.* **3** (1930), 541. (c) Hirao and Takano, *J. Chem. Soc. Japan* **58** (1937), 213. (d) Kimura, *J. Soc. Chem. Ind. (Japan)* **40**, Suppl. binding (1937), 237. (e) Fichter and Schetty, *Helv. Chim. Acta* **20** (1937), 1304. (f) Asharya and Wheeler, *J. Univ. Bombay* **6**, Part II (1937), 134. (g) Aschan, *Bidrag Känn. Finlands naturoch folk.* **77** (1918), 30.

⁸ List, *Liebigs Ann.* **67** (1848), 369.

⁹ Baeyer, *Ber.* **26** (1893), 2863.

¹⁰ Wallach, *Liebigs Ann.* **239** (1887), 18.

¹¹ Wanscheidt and Moldavski, *Ber.* **64** (1931), 921.

- ¹² *Bull. soc. pharm. Bordeaux* **60** (1922), 49. See U. S. Disp., 23rd Ed., 1119.
¹³ Rosenthaler, *Pharm. Ztg.* **76** (1931), 775.
¹⁴ van Urk, *Pharm. Weekblad* **66** (1929), 101.
¹⁵ Perelman, *Pharm. Ztg.* **77** (1932), 1204. *Chem. Abstracts* **27** (1933), 4024.
¹⁶ *Liebigs Ann.* **230** (1885), 248.
¹⁷ *J. Chem. Soc.* **85** (1904), 668.
¹⁸ *Natuurw. Tijdschr.* **14** (1932), 35.
¹⁹ *Boll. chim. farm.* **79** (1940), 1. *Chem. Abstracts* **34** (1940), 7681.
²⁰ *Liebigs Ann.* **230** (1885), 248.
²¹ *J. Chem. Soc.* **85** (1904), 668.
²² 23rd Ed. (1943), 1119.
²³ *Ber.* **26** (1893), 2866.

Terpinene-Terpin

$C_{10}H_{20}O_2$

Mol. Weight 172.26

p-Menthane-1,4-diol. 1-Methyl-4-isopropylcyclohexane-1,4-diol. 1,4-Terpin

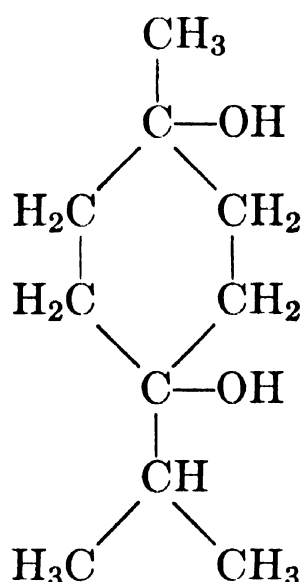

Occurrence.—Terpinene-terpin has not been identified in nature.

Isolation.—Wallach ¹ found that it can be obtained quite readily by the hydration of sabinene, α -thujene, or terpinen-4-ol with dilute sulfuric acid.

Identification.—On dehydration, terpinene-terpin yields 1,4-cineole, terpinen-4-ol and terpinen-1-ol. The mono-*p*-nitrobenzoate m. 117° and the di-*p*-nitrobenzoate m. 172° of the *cis*-1,4-terpin have been characterized by Paget.²

Properties.—Simonsen ³ and Wallach ⁴ reported the following properties:

- | | |
|----|---|
| m. | 137°–138° (<i>trans</i>) ³ |
| m. | 116°–117° (<i>cis</i>) ³ |
| b. | 250° (uncorr.) ⁴ |

Use.—Terpinene-terpin, as such, has not found any use in the perfume or flavor industries.

¹ *Liebigs Ann.* **356** (1907), 200.

² *J. Chem. Soc.* (1938), 832.

³ "The Terpenes," Vol. I (1947), 304.

⁴ *Ber.* **40** (1907), 578.

Carveol

 $C_{10}H_{16}O$

Mol. Weight 152.23

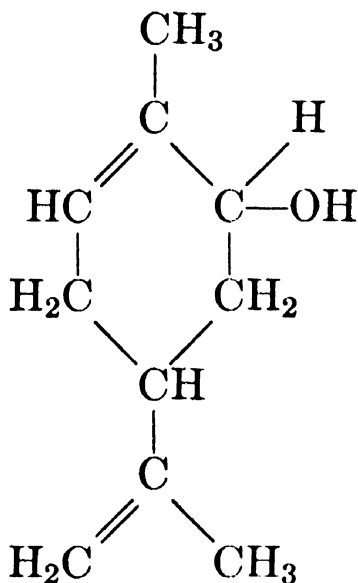
6,8(9)-*p*-Menthadien-2-ol. 1-Methyl-4-isopropenyl-6-cyclohexen-2-ol

This alcohol is a product of the autoxidation of *d*-limonene.

Occurrence.—Small quantities of carveol occur in caraway seed oil.

Isolation.—The most suitable method appears to be that used by Johnston and Read ¹ wherein the crude carveol is converted to the corresponding 3,5-dinitrobenzoate or *p*-nitrobenzoate and purified by fractional recrystallization from alcohol-ethyl acetate mixtures.

Identification.—Although several derivatives have been reported, the exact configuration of the carveol to which they correspond is still obscure in most cases. The most detailed work on completely defined derivatives of this alcohol is that of Johnston and Read ² who report the characteristics of optically homogeneous samples as follows:

	<i>d</i>		<i>l</i>	
	<i>cis</i>	<i>trans</i>	<i>cis</i>	<i>trans</i>
<i>p</i> -Nitrobenzoate, m.	26.5°–28°	77°
3,5-Dinitrobenzoate, m.	92.5°	111.5°	92.0°–92.5°	111°–111.5°

	<i>dl</i>	
	<i>cis</i>	<i>trans</i>
<i>p</i> -Nitrobenzoate, m.	...	101°
3,5-Dinitrobenzoate, m.	91.5°	119°

Properties.—Carveol is a colorless oil. A limited amount of information on this terpenic alcohol has been gathered by Blumann and Zeitschel,³ Genvesse,⁴ Ponndorf,⁵ and Nagasawa,⁶ but the most detailed study on optically pure samples is that of Johnston and Read.⁷ These latter authors reported the several forms of carveol as follows:

PROPERTIES

	<i>d</i>		<i>l</i>		<i>dl</i>	
	<i>cis</i>	<i>trans</i>	<i>cis</i>	<i>trans</i>	<i>cis</i>	<i>trans</i>
	<i>b</i>	b_{10}	b_{10}	b_{10}	b_{10}	b_{16}
<i>m</i>	$24^{\circ}-25^{\circ}$	$24^{\circ}-25^{\circ}$	$24^{\circ}-25^{\circ}$
<i>d</i>	0.9521	0.9484	0.9521	0.9484
α_D	$+23^{\circ} 54'$	$+213^{\circ} 6'$	$-23^{\circ} 54'$	$-213^{\circ} 6'$
<i>n_D</i>	1.4959	1.4942	1.4959	1.4942	n_D^{19}	n_D^{19}
	d_4^{25}	d_4^{25}	d_4^{25}	d_4^{25}	d_4^{18}	d_4^{18}
	$[\alpha]_D^{25}$	$[\alpha]_D^{25}$	$[\alpha]_D^{25}$	$[\alpha]_D^{25}$
	n_D^{25}	n_D^{25}	n_D^{25}	n_D^{25}	n_D^{19}	n_D^{19}
	$101.2^{\circ}-101.4^{\circ}$	$102.2^{\circ}-102.4^{\circ}$	$101.2^{\circ}-101.4^{\circ}$	$102.2^{\circ}-102.4^{\circ}$	108°	108°

Oxidation of carveol with chromic acid yields carvone.

Use.—Carveol is not readily available and, therefore, has not attained any noteworthy use in the perfume or flavor industries.

¹ *J. Chem. Soc.* (1934), 233.

² *Ibid.*

³ *Ber.* **47** (1914), 2626.

⁴ *Compt. rend.* **132** (1901), 414.

⁵ *Z. angew. Chem.* **39** (1926), 138.

⁶ *Repts. Imp. Ind. Research Inst., Osaka, Japan* **19**, No. 4 (1938). *Chem. Abstracts* **34** (1940), 219.

⁷ *J. Chem. Soc.* (1934), 233.

Dihydrocarveol

$C_{10}H_{18}O$

Mol. Weight 154.24

8(9)-*p*-Menthen-2-ol. 1-Methyl-4-isopropenylcyclohexan-2-ol

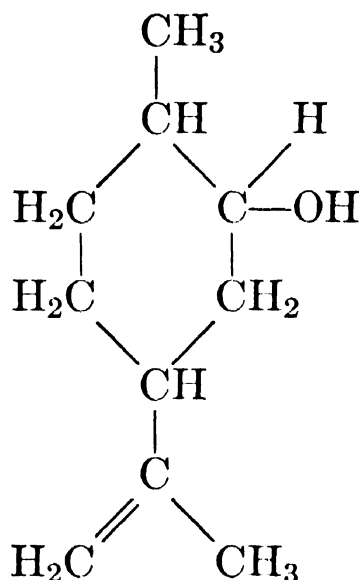

Occurrence.—Schimmel & Co.¹ isolated dihydrocarveol from caraway seed oil; Nelson² found it as acetate in American spearmint oil.

Isolation.—The fraction of caraway seed oil b_6 94° – 97.5° is benzoylated with benzoyl chloride in pyridine, the product submitted to steam distillation, and the residue saponified.

Identification.—Dihydrocarveol may be identified:

(1) By the preparation of its phenylurethane, optically active form $m.$ 87° , inactive form $m.$ 93° .

(2) By the oxidation of dihydrocarveol with chromic acid in glacial acetic acid to dihydrocarvone, and by the preparation of the oxime, optically active form $m.$ 88° – 89° , inactive form $m.$ 115° – 116° , according to Wallach et al.³ (see below).

(3) Through the *p*-nitrobenzoate $m.$ 37° , and the 3,5-dinitrobenzoate $m.$ 121.5° – 122° prepared from *d*-dihydrocarveol by Johnston and Read.⁴

Properties.—Dihydrocarveol is an oil possessing a terpineol-like odor. Containing three asymmetric carbon atoms, dihydrocarveol can theoretically exist in eight optically active and four externally compensated modifications.

When prepared artificially—for instance, by the reduction of *d*- or *l*-carvone—dihydrocarveol is usually a mixture of stereoisomers.

Wallach et al.⁵ early reported the characteristics of this alcohol obtained by reduction of *d*-carvone; these data were later confirmed by Tschugaev.⁶ By a like reduction, Johnston and Read⁷ carefully prepared dihydrocarveol with these properties:

b_{15}	106.8°–107.2°	$[\alpha]_D^{16}$	+34° 12'
d_4^{16}	0.9223	n_D^{16}	1.4784

The analog of this isomer was obtained by Tschugaev et al.⁸

This compound, however, bears resemblance to that described later as “neodihydrocarveol” by Johnston and Read:⁹

b_{18}	101°–102°
α_D^{14}	–33° 13'
n_D^{14}	1.4812

that yields a 3,5-dinitrobenzoate m. 138°–138.5°, and a *p*-nitrobenzoate m. 107°.

Tschugaev,¹⁰ employing the decomposition of dihydrocarvylxanthogenamide, isolated yet another isomer (closely related to that of Wallach) which he described as “*d*- α -dihydrocarveol”:

b_{749}	222.5°–223°	$[\alpha]_D$	+33° 52'
d_4^{20}	0.9204	n_D^{20}	1.47818

As far as the natural product is concerned, Schimmel & Co.¹¹ found these properties for dihydrocarveol isolated from caraway seed oil:

b_{7-8}	100°–102°	α_D	–6° 14'
d_{15}^{15}	0.9368	n_D^{20}	1.48364

Tschugaev¹² obtained the antipode of the Schimmel dihydrocarveol through the xanthogenamide decomposition and described it as “*d*- β -dihydrocarveol”—

b_{20}	120°	$[\alpha]_D$	+7° 38'
d_4^{20}	0.9266	n_D^{20}	1.48087

More work is necessary to demonstrate the intramolecular spatial relationships between the products of these different reactions and the extent of their purity.

When oxidizing dihydrocarveol with chromic acid in glacial acetic acid, Wallach et al.¹³ obtained dihydrocarvone b. 221°–222°, d_{19} 0.928, n_D 1.47174. The dihydrocarvone from *d*-dihydrocarveol was thereby laevorotatory, the dihydrocarvone from *l*-dihydrocarveol dextrorotatory. The corresponding optically active and inactive dihydrocarvoximes have been described above.

Wallach and collaborators¹⁴ also showed that the oxidation of dihydrocarveol with potassium permanganate yields a glycerol, viz., *p*-menthane-2,8,9-triol which, with dilute sulfuric acid, is converted into an unsaturated oxide $b_{20} 95^\circ$, $d 0.9647$, $n_D 1.4844$. This oxide, in turn, yields a crystalline dibromide $m. 58^\circ$, and with hydroxylamine two isomeric hydroxylamino-derivatives $m. 111^\circ$ – 112° , and 164° – 165° , respectively. These derivatives may be used for the characterization of dihydrocarveol.

The acetate of dihydrocarveol possesses an odor typical of spearmint.

Use.—Dihydrocarveol has not found any noteworthy use in the flavor or perfume industries.

¹ *Ber. Schimmel & Co.*, April (1905), 50.

² *U. S. Dept. Agr., Bureau of Chemistry, Circ. No. 92* (1912).

³ *Liebigs Ann.* **275** (1893), 115.

⁴ *J. Chem. Soc.* (1934), 236.

⁵ *Liebigs Ann.* **275** (1893), 111.

⁶ *Ber.* **33** (1900), 735. *J. Russ. Phys. Chem. Soc.* **36** (1904), 992.

⁷ *J. Chem. Soc.* (1934), 236.

⁸ *J. Russ. Phys. Chem. Soc.* **39** (1907), 1333. *Chem. Zentr.* I (1908), 1180. *Zeit. physik. Chem.* **76** (1911), 471.

⁹ *J. Chem. Soc.* (1934), 236.

¹⁰ *Ber.* **35** (1902), 2479. *J. Russ. Phys. Chem. Soc.* **36** (1904), 1001.

¹¹ *Ber. Schimmel & Co.*, April (1905), 50.

¹² *Ber.* **35** (1902), 2479. *J. Russ. Phys. Chem. Soc.* **36** (1904), 1001.

¹³ *Liebigs Ann.* **275** (1893), 111.

¹⁴ *Ibid.* **277** (1893), 151; **279** (1894), 386; **324** (1902), 91. Cf. Simonsen, "The Terpenes," Vol. I (1947), 280.

Pulegol

$C_{10}H_{18}O$

Mol. Weight 154.24

4(8)-*p*-Menthen-3-ol. 1-Methyl-4-isopropylidencyclohexan-3-ol

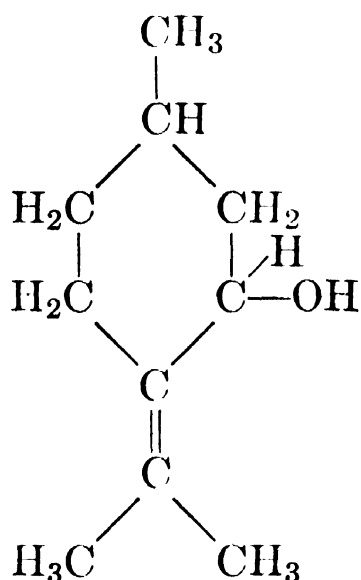

Occurrence.—This alcohol has not yet been observed in nature, due probably and partly to its marked chemical sensitivity. However, biological experiments by Teppati¹ have demonstrated that pulegone can give rise to

pulegol both *in vivo* and *in vitro*. Since pulegol constitutes an intermediate in the formation of menthol, its occurrence at least in combined form in essential oils seems quite likely.

Isolation and Identification.—The fraction containing the alcohol mixture as isolated by steam distillation is treated with phthalic anhydride in the cold to obtain the acid phthalates; these are separated by fractional crystallization. The properties of the acid phthalate corresponding to that of *l*-pulegol are: m. 212° , $[\alpha]_{\text{D}} -86^{\circ} 48'$, according to Paolini.²

Properties.—Paolini³ obtained an *l*-pulegol by a sodium-alcohol reduction of *d*-pulegone, and purified it by the phthalate method:

m.	$46^{\circ}-47^{\circ}$
b.	$209^{\circ}-210^{\circ}$
$[\alpha]_{\text{D}}$	$-54^{\circ} 3'$

A *d*-pulegol has been reported by Doeuvre and Perret⁴ by the reduction of *d*-pulegone with isopropyl aluminum and purification through fractional distillation:

b_{12}	91.5°	n_{D}^{18}	1.4714
d_4^{18}	0.909	Mol. refr.	{ Calc. 47.24 { Obs. 47.37
$[\alpha]_{18}^{578}$	$+70^{\circ} 0'$		

Use.—Pulegol, as such, is not used in the perfume or flavor industries.

¹ *Arch. intern. pharmacodynamie* **57** (1937), 440. *Chem. Abstracts* **32** (1938), 5504.

² *Atti accad. Lincei* [5] **28** (1919), 238.

³ *Ibid.*, 190, 236.

⁴ *Bull. soc. chim.* [5] **2** (1935), 305.

Isopulegol

$\text{C}_{10}\text{H}_{18}\text{O}$

Mol. Weight 154.24

8(9)-*p*-Menthen-3-ol. 1-Methyl-4-isopropenylcyclohexan-3-ol

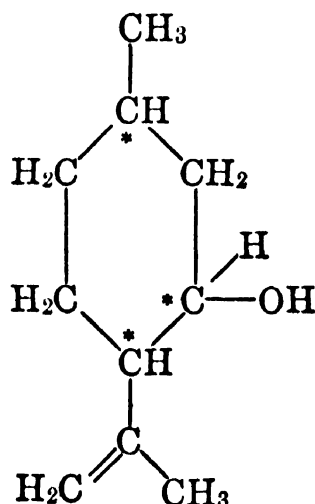

Tiemann and Schmidt¹ reported that the acetate of isopulegol is formed by the treatment of citronellal with acetic acid anhydride. Semmler² pre-

pared isopulegol by the action of acetic acid anhydride on the enolic form of citronellal.

Occurrence.—Naves ³ reported the occurrence of isopulegol in lemongrass oil of French equatorial Africa. Penfold ⁴ identified the alcohol in *Leptospermum liversidgei* var. B. However, the remarks of Naves are particularly worthy of note in connection with all observations as to the natural occurrence of this alcohol. This author points out that isopulegol occurs only in those oils of which citronellal is also a constituent. This aliphatic aldehyde readily isomerizes to isopulegol, which fact may account for the presence of the latter compound in an oil.

Identification.—(1) According to Wallach,⁵ isopulegol can be characterized by oxidation to isopulegone and by preparing the oxime thereof. The optically active oxime melts at 121°; at 125°–126°, according to Sakurai;⁶ the optically inactive oxime at about 140°.

The semicarbazone, too, may serve for the identification of the derived isopulegone. The semicarbazone from the optically active forms is usually reported as melting near 172°. However, Doeuvre ⁷ has shown that the two semicarbazones corresponding to the stereoisomeric alcohols formed from *d*-citronellal have these properties:

I m.	172°–173°	$[\alpha]_{578}^{23}$	–29° 58'
II m.	156°	$[\alpha]_{578}^{23}$	+4° 30'

The optically inactive semicarbazone m. 182°–183°.

(2) According to Behal,⁸ isopulegol can also be characterized by the preparation of its allophanate m. 219°.

(3) The naphthylurethane of *d*-isopulegol melts at 112°–113° (cf. Penfold ⁹).

(4) The *p*-toluene sulfonic ester of the active form melts at 95°, according to Stoll.¹⁰

Properties.—Isopulegol is a colorless liquid possessing an odor which resembles menthol; it appears to be a mixture of stereoisomeric alcohols. Theoretically this hydroxy compound can exist in four stereoisomeric pairs of *d*- and *l*-rotatory compounds. The system is comparable to the menthols. The scheme of nomenclature proposed for application thereto has been suggested by Pickard, Hunter, Lewcock and de Pennington ¹¹ who recorded the following properties on certain of these isopulegols:

Isopulegols

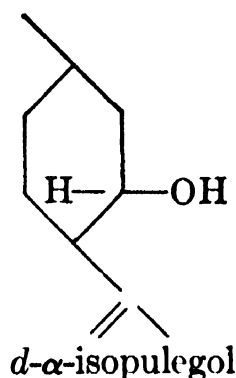
trans-(CH₃,C₃H₅)

$d_4^{19.5}$	0.9172
$[\alpha]_{5461}^{19.5}$	+34° 30'
$[\alpha]_D^{19.5}$	+29° 18'
(contains 10% <i>l</i> -isopulegol)	

Forms the more soluble acid
phthalate:

m. 117°; $[\alpha]_D +30^\circ 6'$ (in alc.
c = 5)

Reduced by Pd to *d*-neomenthol:

$[\alpha]_{5461}^{19} +10^\circ 55'$

Products obtained by Tiemann and Schmidt,¹² Semmler,¹³ Wegscheider and Späth,¹⁴ and later Doeuivre¹⁵ are admittedly mixtures, and all display very small rotations, $[\alpha]_D < \pm 2^\circ$.

Use.—Isopulegol has found limited use in the scenting of soaps and technical preparations.

¹ *Ber.* **29** (1896), 913; **30** (1897), 27.

² *Ber.* **42** (1909), 2016.

³ *Parfums France* **9** (1931), 69.

⁴ *J. Proc. Roy. Soc. N. S. Wales* **65** (1932), 185.

⁵ *Liebigs Ann.* **365** (1909), 251.

⁶ *J. Pharm. Soc. Japan* **55** (1935), 86. *Chem. Abstracts* **29** (1935), 7581.

⁷ *Bull. soc. chim.* [4], **53** (1933), 589.

⁸ *Ibid.* [4] **25** (1919), 479.

⁹ *J. Proc. Roy. Soc. N. S. Wales* **65** (1932), 185.

¹⁰ *Z. physiol. Chem.* **246** (1937), 9.

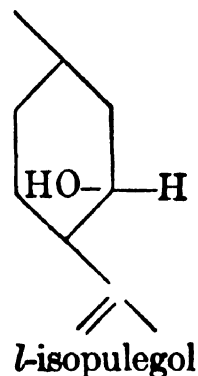

b_{14}	94°
b_{10}	88°
d_4^{20}	0.9110
$[\alpha]_{5461}^{20}$	-25° 54'
n_D^{20}	1.4723
Mol. refr.	{ Obs. 47.41 Calc. 47.16

Forms the sparingly soluble acid
phthalate:

m. 106°; $[\alpha]_{5893}^{\sim 25} -23^\circ 33'$ (in alc.
c = 5)

Mg salt m. 111°; $[\alpha]_{5893}^{20} +18^\circ 12'$

Strychnine salt m. 205°

Reduced by Pd to *l*-menthol:

m. 42°; $[\alpha]_D^{47} -49^\circ 24'$

¹¹ *J. Chem. Soc.* **117** (1920), 1248.

¹² *Ber.* **29** (1896), 914.

¹³ *Ber.* **42** (1909), 2014.

¹⁴ *Monatsh.* **30** (1910), 825.

¹⁵ *Bull. soc. chim.* **53** (1933), 589.

SUGGESTED ADDITIONAL LITERATURE

Riki Horiuchi, "Transformation of Aliphatic Terpenes into Monocyclic Terpenes. Synthesis of Menthol," Takasago Perfumery Co. *Mem. Coll. Sci. Kyoto Imp. Univ. Series A*, **11**, No. 3 (reprint) 171-97 (1928). *Chem. Abstracts* **22** (1928), 3886.

Y. R. Naves, "Some New Aspects of the Chemistry of Isopulegol," *Parfums France* **6** (1928), 191, a review.

Piperitol

$C_{10}H_{18}O$

Mol. Weight 154.24

1-*p*-Menthen-3-ol. 1-Methyl-4-isopropyl-1-cyclohexen-3-ol.

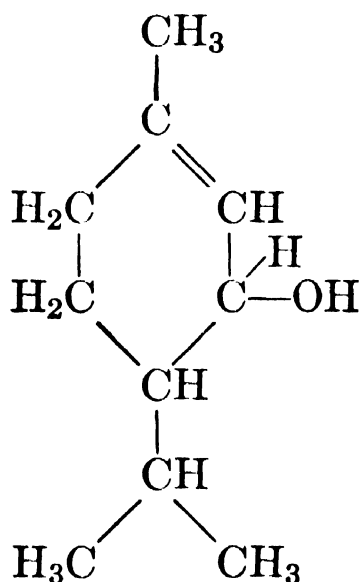

Occurrence.—This secondary alcohol does not seem to be widely distributed in nature. *l*-Piperitol has been found in a few eucalyptus oils, especially in oil of *Eucalyptus radiata* Sieb. *d*-Piperitol was reported by Simonsen¹ in the oil from an unidentified species of *Andropogon* growing in the Etawah district, U.P., India.

Isolation.—By fractional distillation.

Identification.—(1) Oxidation of piperitol with chromic acid yields piperitone, 1-*p*-menthen-3-one, which may be easily characterized.

(2) The dinitrobenzoate m. 84°-85°, $[\alpha]_D^{14} -30^\circ 0'$ ($c = 0.1$ in $CHCl_3$) has been prepared by Read and Walker.²

Properties.—Piperitol is a viscid oil with a pleasant odor. The properties set forth in the following table have been reported by Baker and Smith,³ Read and Walker,⁴ Simonsen,⁵ and Read and Storey:⁶

Isomer	Source	b.	d	n _D	α
<i>l</i> -Piperitol	<i>Eucalyptus radiata</i> Sieb.	b ₁₀	d ₁₂ ²²	n _D ²²	α _D
<i>l</i> -Piperitol	Reduction of <i>l</i> -piperitone	b ₁₃		n _D ¹⁹	[α] _D ¹⁶
<i>d</i> -Piperitol	Andropogon oil	b ₂₀₀	d ₃₀ ³⁰	n _D ³⁰	[α] _D ³⁰
<i>d</i> -Piperitol	Synthetic	b ₁₆	d ₄ ²⁵	n _D ¹⁸	α _D ¹⁶
<i>dl</i> -Piperitol	Synthetic	b _{19.5}		n _D ¹⁸	(c = 1.4, in alc.) +46° 0' ⁵ +40° 13' ⁶

-34° 6' ³
-24° 30' ⁴

(c = 1.4, in alc.)

+46° 0' ⁵
+40° 13' ⁶

Since piperitol contains two asymmetric carbon atoms, it can exist in four optically active isomeric forms. Read ⁷ expressed the opinion that the naturally occurring piperitol possesses the *cis*-configuration.

Use.—Piperitol has not found any noteworthy use in the perfume or flavor industries.

¹ *Indian Forest Records* **10** (1924), 161.

² *J. Chem. Soc.* (1934), 312.

³ "Research on the Eucalypts," 2d Ed. (1920), 373.

⁴ *J. Chem. Soc.* (1934), 308.

⁵ *Indian Forest Records* **10** (1924), 161.

⁶ *J. Chem. Soc.* (1930), 2770.

⁷ *J. Soc. Chem. Ind.* **49** (1930), 1008.

Carvomenthol

(Tetrahydrocarveol)

C₁₀H₂₀O

Mol. Weight 156.26

2-*p*-Menthanol. 1-Methyl-4-isopropylcyclohexan-2-ol

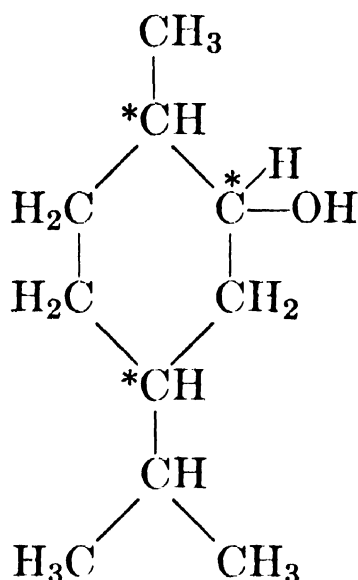

Occurrence.—Although this cyclic saturated secondary alcohol has not yet been definitely identified in essential oils, it is closely related genetically to other natural products, i.e., carvone and carvacrol. The work of Johnston and Read ¹ has conclusively demonstrated the existence of dynamic equilibria among members of this series which fact may in part account for the failure specifically to assay this alcohol. Products isolated in the past as carvomenthols are at best mixtures of stereoisomers.

The carvomenthols are stereochemically similar to the menthols, by virtue of the three asymmetric carbon atoms, and should be capable of existing in

CARVOMENTHOLS

Isomer	Properties				Derivatives			[R _L] _D obs. (47.70 calc.)
	b. °C.	d ₄ ^t	[α] _D ^t	n _D	<i>p</i> -Nitrobenzoate	3,5-Dinitrobenzoate	Acid Phthalate	
<i>d</i> -	b ₁₄ 101.8-102	t = 13° 0.9056	t = 13° +27° 41'	n ¹⁷ 1.4629 n ¹² 1.4650	m. 60° [α] _D ¹⁷ +51° 42' (in CHCl ₃)	m. 107° [α] _D ¹³ +52° 48' (in CHCl ₃)	m. 90°-91° [α] _D +57° 48' (in alc.)	47.62
* <i>l</i> -neo	b ₁₈ 102	t = 20° 0.9012	t = 21° -41° 42'	n ²⁰ 1.4632	m. 95° [α] _D -22° 48' (in CHCl ₃)	m. 129° [α] _D -22° (in CHCl ₃)	...	47.64
* <i>dl</i> -neo	n ²⁰ 1.4637	m. 91°-92°	m. 101°
† <i>l</i> -iso	b ₁₇ 106	t = 20° 0.9109	t = 16° -17° 43'	n ²⁰ 1.4662 n ¹⁴ 1.4683	m. 64.5° [α] _D -27° 18' (in CHCl ₃)	m. 111° [α] _D -26° 42' (in CHCl ₃)	...	47.54
<i>dl</i> -iso	b ₂₀ 110	t = 20° 0.904	...	n ¹⁸ 1.4669	m. 85.5°	m. 94.5°
<i>l</i> -neoiso	...	t = 20° 0.9102	t = 17° -34° 42'	n ²⁰ 1.4676 n ¹⁶ 1.4689	m. 54°-55° [α] _D -23° 42'	m. 71°-72° [α] _D -16° 0'	...	47.66

* Mentholic aroma.

† Most pronounced mentholic odor of series.

eight optically active and four racemic forms. The nomenclature likewise follows the pattern of the menthols.

Carvomenthol	<i>d, l, dl</i>
Isocarvomenthol	<i>d, l, dl</i>
Neocarvomenthol	<i>d, l, dl</i>
Neoisocarvomenthol	<i>d, l, dl</i>

The "iso" compounds result from isomerism around the atom C₁ and the "neo" derivatives from that around C₂. Details as to the specific configurations to be assigned to these classes will be found in the literature. From these studies, certain well-defined derivatives have been developed which may be used for the isolation and identification of stereochemically homogeneous forms.

Isolation and Identification.—For the stereoisomers and their derivatives, Johnston and Read² reported the properties tabulated on page 214.

Since the study by Johnston and Read,³ attention has been given to selected members of the carvomenthol series by Nagasawa,⁴ Palfray and Sabetay,⁵ Hückel and Wilip,⁶ Palfray,⁷ and Dodge and Kremers.⁸ However, these workers apparently did not prosecute the purification of their several isomers as vigorously as did Johnston and Read; thus there is reason to believe, from the physical data, that the reported isomers are not optically homogeneous.

Use.—Carvomenthol, as such, is not used in our industries.

¹ *J. Chem. Soc.* (1935), 1138.

² *Ibid.*

³ *Ibid.*

⁴ *Repts. Osaka Imp. Ind. Res. Inst.* **19**, No. 4 (1938). *Chem. Abstracts* **34** (1940), 219.

⁵ *Bull. soc. chim.* [5], **5** (1938), 1423.

⁶ *J. prakt. Chem.* **158** (1941), 21.

⁷ *Bull. soc. chim.* [5], **7** (1940), 401.

⁸ *J. Am. Pharm. Asscn.* **31** (1942), 525.

Menthol

C₁₀H₂₀O

Mol. Weight 156.26

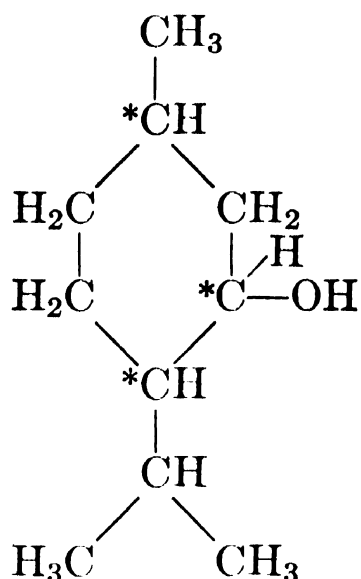
3-*p*-Menthanol. 1-Methyl-4-isopropylcyclohexan-3-ol

The work on the stereoisomerism of this cyclic, saturated, secondary alcohol and the preparation of the pure stereoisomers, an extremely difficult problem, has been shared by many prominent workers. The present monograph will deal primarily with the isolation and identification of those stereoisomeric menthols that occur naturally in essential oils. Thus, after a general introduction to the menthols, isomenthols, neomenthols, and neoisomenthols, detailed attention will be given to *l*-menthol and *d*-neomenthol which, among the possible stereoisomers, are the only ones so far encountered in nature. The very important *l*-menthol occurs as a main constituent in peppermint oil (*Mentha piperita*) and Japanese type mint oil, while small quantities of the isomeric liquid *d*-neomenthol accompany the *l*-menthol in the Japanese mint oil (*Mentha arvensis*). With the improved methods of isolation now at hand, other of the isomers, too, may be found in nature.

Menthol contains three asymmetric carbon atoms; therefore, it can exist in four externally compensated and eight optically active forms. Moreover, the configuration of the molecule allows of geometric isomerism. For an appreciation of the atomic spatial arrangement in these twelve forms, the reader should consult original literature on the subject. However, the relationship between the various members is clearly illustrated in the following "family tree."¹

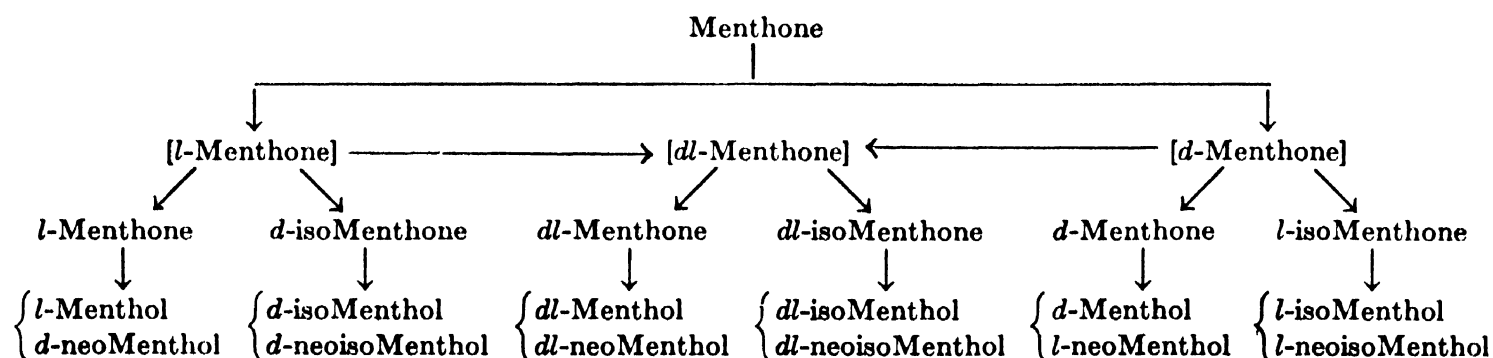

The resolution of these many forms and the determination of indices of purity have been beset with many complications. It will be obvious, from a study of the physicochemical properties, that these isomers do not lend themselves readily to separation by rectification because of the close similarity of their boiling points. Nor is the melting point² an altogether safe guide unless the investigator considers the mixed-crystal systems and polymorphism that exist among certain of these compounds. Findings,³ relating to optical properties, further complicate the physical data of the menthols. In this connection, Hückel and Niggemeyer⁴ have shown that the solvent has a pronounced effect on optical rotation, most marked with the neoiso- and isomenthols.

The difficulties attendant upon separation may in part account for the wide difference in physical and organoleptic characteristics of commercial samples.

In spite of these peculiarities, however, workers have devised methods for the laboratory preparation and characterization of the various menthols, sometimes in a high state of purity. Bliss and Glass,⁵ and Macht⁶ investigated the physiological effects of the isomers. Huggett⁷ has developed determinants for mixtures, while many other workers ascertained the physical properties of the isomers. The more pertinent data obtained in these investigations are reproduced in the tables below.

The properties shown in the table below have been reported by Read, Robertson and Cook,⁸ Behal,⁹ Read and Grubb,¹⁰ Haller and Martine,¹¹ Zeitschel and Schmidt,¹² Vavon and Couderc,¹³ Pickard and Littlebury,¹⁴ Grubb and Read,¹⁵ Huggett,¹⁶ Kondakov and Bachtshiev,¹⁷ Beckmann,¹⁸ Barney and Hass,¹⁹ Hückel and Tappe,²⁰ Read and Grubb,²¹ Shelswell and Williams,²² Huggett,²³ Gildemeister and Hoffmann,²⁴ Read and Grubb,²⁵ Read, Grubb and Malcolm,²⁶ Read, Robertson and Cook,²⁷ Abbot, Christie and McKenzie,²⁸ Blagden and Huggett,²⁹ van Gelderen,³⁰ Schmidt and Schulz,³¹ Harms,³² Hückel and Reimer,³³ Hückel and Niggemeyer,³⁴ Williams,³⁵ Woodward, Kohman and Harris,³⁶ Kobe, Okabe, Ramstad and Huemmer,³⁷ Kenyon and Pickard,³⁸ and Wright:³⁹

Properties of the <i>d</i> -Menthols							Derivatives	
	b. °C.	m. °C.	d	$[\alpha]_D^\circ$	n_D	Type	m. °C.	
<i>d</i> -Menthol	b _{12.5} 99 ²⁵	42-43 ²⁵	...	$[\alpha]_D^{17}$ +49° 57' ²⁵	...	Phenylurethane Menthoxy acetate (<i>l</i>) (<i>d</i>) Malonate (di) 3,5-Di-NO ₂ benzoate β - <i>d</i> -Glucuronide	112-113 ³⁵ 91.5 ²⁵ 60 ²⁵ 59-60 ²⁸ 153-154 ³⁵ 120-122 ³⁵	
<i>d</i> -iso- Menthol	b. 218.6 ²³ b ₁₀ 96.2-96.8 ²⁶	83 ³⁴ 81.5- 82.5 ^{23,26,27}	d_{30} 0.9040 ²³	$[\alpha]_D^{15}$ +27° 0' ²⁷ (in ben- zene) $[\alpha]_D^{20}$ +26° 30' ³⁴ (in alc.) +26° 0' ²³ (in alc.) $[\alpha]_D^{17}$ +25° 54' ²⁶ (<i>c</i> = 2.03, in alc.)	n_D^{60} 1.4510 ²³	H-phthalate <i>d</i> -Camphor-10- sulfonate <i>l</i> -Camphor-10- sulfonate <i>p</i> -NO ₂ -benzoate 3,5-Di-NO ₂ benzoate Menthoxy acetate (<i>l</i>) and (<i>d</i>) <i>p</i> -Toluene sulfonate	107.5- 108.5 ⁸ 30-31 ²⁶ 33-34 ²⁶ 54 ²⁶ 145 ²⁶ liq. ²⁶ 84.5 ³⁴	

<i>d</i> -neo-Menthol	b ₇₅₅₋₇₆₀	211.5-212.5 ^{11,12}	* - 22 ¹⁵	d ₃₀ 0.8917 ¹⁶	[α] _D ²⁰ + 20° 0' ¹⁶ (20% in alc.)	n _D ⁶⁰ 1.4448 ¹⁵ 1.4450 ¹⁶	1.4594- 1.4603 ^{12,13,16} 1.4617 ¹⁵	H-phthalate <i>p</i> -Toluene sulfonate 3,5-Di-NO ₂ benzoate Menthoxy acetate (<i>l</i>) <i>p</i> -NO ₂ benzoate H ₃ PO ₄	142-144 ¹⁴ 63 ²⁰ 155 ²² 28.5 ²¹ 94- 94.5 ^{15,22} 86 ²⁹	
	b ₂₀	107-108 ¹³		d ₄ ²² 0.8970 ¹³	[α] _D ¹⁸ + 19° 42' ¹⁴	n _D ²⁰⁻²²				
	b ₁₆	98 ¹⁴		d ₁₅ ¹⁵ 0.9003 ¹²	[α] _D ¹⁶ + 17° 48' ¹⁵	n _D ¹⁷				
	b ₈	87 ²¹								
<i>d</i> -neoiso-Menthol	b.	214-215 ^{10,31}	- 8 ^{10,34}	d ₃₀ 0.9041 ²³	[α] _D ²⁰ + 2° 0' ³⁴ (in alc.)	n _D ⁶⁰ 1.4503 ²³		H-phthalate <i>p</i> -NO ₂ benzoate 3,5-Di-NO ₂ benzoate <i>d</i> -Camphor-10-sulfonate <i>l</i> -Camphor-10-sulfonate H ₃ PO ₄ α-Naphthylurethane Benzoyl- <i>p</i> -amino benzoate <i>p</i> -Toluene sulfonate	85-86 ³¹ 72.5-73 ¹⁰ 100.5- 101 ^{10,34} 69-70 ¹⁰ 84-86 ¹⁰	
	b ₁₁	91-91.5 ³⁴		d ₄ ¹⁸ 0.9131 ¹⁰	[α] _D ¹⁶ + 2° 12' ¹⁰ (<i>c</i> = 2.0, abs. alc.)	n _D ²⁰ 1.4649 ²³				
	b _{7.5}	84.2 ¹⁰				n _D ¹⁸ 1.4674 ¹⁰				

* Very difficult to crystallize.

		Properties of <i>l</i> -Menthols				Derivatives	
	b. °C.	m. °C.	d	$[\alpha]_D^\circ$	n_D	Type	m. °C.
<i>l</i> -Menthol	b. 216.5 ²³	* 42-43 ^{23,25}	† $d_4^{81.4}$ 0.8523 ³³	$[\alpha]_D^{20}$ -50° 0' ²³ (in alc.)	n_D^{60} 1.4461 ²³	H-phthalate	122 ¹⁴
			† d_4^{62} 0.8682 ³³	$[\alpha]_D^{16}$ -49° 0' ²⁵ (<i>c</i> = 2.0, in alc.)	n_D^{25} 1.4580 ³⁹	Phenylurethane	112 ¹⁸
			d_{30} 0.8911 ²³ d_4^{20} 0.9007 ³⁸ † d_7 0.886- 0.887 ³²		n_D^{20} 1.4610 ¹²	Allophanate	213 ⁹
						α -Naphthylurethane	126 ²⁴
						Benzoate	54.5 ¹⁸
						Succinate (di)	62 ²⁴
						Oxalate (di)	67-68 ²⁴
						Phthalate (di)	133 ²⁴
						Menthoxy acetate (<i>d</i>)	91 ²⁵
						(<i>l</i>)	60 ²⁵
						<i>d</i> -Camphor-10-sulfonate	125.5 ²⁶
						<i>l</i> -Camphor-10-sulfonate	47 ²⁶
						<i>p</i> -NO ₂ benzoate	61-62 ²⁶
						3,5-Di-NO ₂ benzoate	153 ²⁶
						β -Naphthoate	77 ²⁶
						Malonate (di)	59-60 ²⁸
						H ₃ PO ₄	74 ²⁹
						4-Diphenyl carbamate	157 ³⁰
						Menthyl hydrazide	101.5-102 ³⁶

<i>l</i> -iso-Menthol	b ₁₉ 103-107 ⁸	82.5 ¹⁰	...	[α] _D ¹⁵ -24° 6' ⁸ (c = 1.8, abs. alc.)	...	<i>d</i> -Camphor-10-sulfonate	33-34 ²⁶
<i>l</i> -neo-Menthol	b ₂₁ 105 ¹⁴ b ₁₀ 97.6 ²¹	...	d ₄ ²⁰ d ₄ ⁰	[α] _D ¹⁸ -19° 36' ¹⁴ [α] _D ¹⁷ -20° 42' ²¹ (in alc.) ²¹	n _D ²⁰ 1.4603 ¹⁴ n _D ¹² 1.4638 ²¹	Phenylurethane 3,5-Di-NO ₂ benzoate Menthoxy acetate (<i>l</i>) (<i>d</i>) <i>p</i> -NO ₂ benzoate <i>d</i> -Camphor-10-sulfonate <i>l</i> -Camphor-10-sulfonate	107-108 ¹⁴ 153 ²¹ 64 ²¹ 28.5 ²¹ 95 ²¹ 116 ²⁶ 92 ²⁶
<i>l</i> -neiso-Menthol

* Exists in four allotropic forms from methyl alcohol m: I 31°, II 33°, III 35° and IV 44°.

† Made in connection with γ measurements.

‡ Made in connection with molecular polarization measurements.

		Properties of <i>dl</i> -Menthols				Derivatives	
		b. °C.	m. °C.	d	n _D	Type	m. °C.
<i>dl</i> -Menthol	b.	216.5 ^{23,37}	* 38 ²³	d ₃₀ 0.8911 ²³	n _D ²⁰ 1.4461 ²³ n _D ²⁰ 1.4615 ²³	Phenylurethane	102-104 ¹⁴
						H-phthalate	131-132 ⁸
<i>dl</i> -iso-Menthol	b.	218.6 ²³	53-54 ²⁶	d ₃₀ 0.9040 ²³	n _D ⁶⁰ 1.4510 ²³ n _D ¹⁶ 1.4660 ⁸	H-succinate	85 ¹⁴
	b _{10.5}	97.4 ²⁶	53.5 ^{23,34}			<i>p</i> -NO ₂ benzoate	91 ²⁶
<i>dl</i> -neo-Menthol	b.	211.7 ¹⁶	† 50-52 ^{12,14,18,16,19}	d ₃₀ 0.8917 ¹⁶	n _D ⁶⁰ 1.4450 ¹⁶	3,5-Di-NO ₂ benzoate	121 ²⁶
	b ₁₆	103-105 ¹⁴		d ₂₀ 0.9052 ¹⁷	n _D ²⁰ 1.4600 ¹⁶ n _D 1.4645 ¹⁷	β-Naphthoate	70 ²⁶
<i>dl</i> -neo-Menthol	b ₁₂	98-100 ¹⁷				H ₃ PO ₄	54.5-55.5 ²⁸
	b.	214.6 ²³	14 ¹⁰	d ₃₀ 0.9041 ²³	n _D ⁶⁰ 1.4503 ²³ n _D ²⁰ 1.4649 ²³ n _D ¹⁷ 1.4676 ¹⁰	Malonate (di)	74 ²⁹
	b ₆	81 ¹⁰	13.5 ²³			H ₃ PO ₄	107-108, ⁸ 117 ²⁶
						H-succinate	64.5 ^{26,34}
						<i>p</i> -Toluene sulfonate	130 ²⁶
						Benzoyl- <i>p</i> -amino benzoate	46 ²⁹
						Phenylurethane	64 ³⁴
						H-phthalate	119-120 ³⁴
						3,5-Di-NO ₂ benzoate	114 ^{12,14}
						<i>p</i> -NO ₂ benzoate	175-177 ¹⁴
						β-Naphthoate	130 ²¹
						H ₃ PO ₄	78.5 ²¹
						H-succinate	98 ²¹
						<i>p</i> -NO ₂ benzoate	86 ²⁹
						3,5-Di-NO ₂ benzoate	67-68 ¹⁴
						<i>p</i> -Amino benzoate	63-64 ¹⁰
							73-73.5 ¹⁰
							liq.

* *dl*-Menthol can exist in either of two crystalline modifications, I m. 28° and II m. 38°. The higher melting passes over to the other below the melting point of II.

† Tends to remain in liquid state even when very pure.

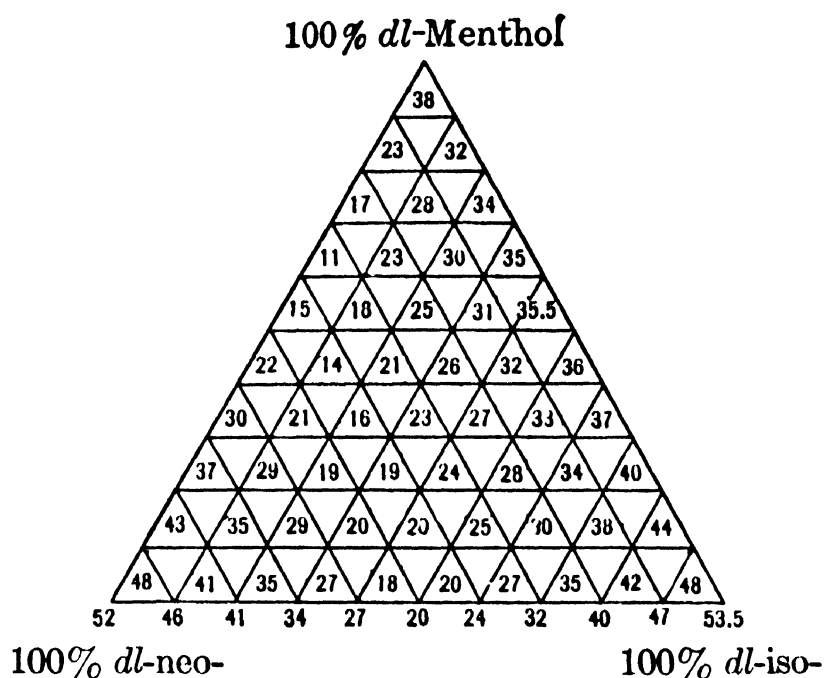

Melting point diagram of the system *dl*-Menthol, *dl*-neoMenthol, *dl*-isoMenthol. The numerals indicate the melting point in °C.⁴⁰

- ¹ Huggett, *Quart. J. Pharm. & Pharmacol.* **15** (1942), 218.
- ² Re: melting point data see: (a) Serini, *Pharm. Ztg.* **78** (1933), 979; (b) Wright, *J. Am. Chem. Soc.* **39** (1917), 1515; (c) Bridgman, *Proc. Am. Acad. Arts Sci.* **72** (1938), 227; (d) Waters and Beal, *J. Am. Pharm. Assocn.* **34** (1945), 52.
- ³ Re: rotatory properties of menthyl compounds, (a) Rule and McLean, *J. Chem. Soc.* (1932), 1400; McLean, (1934), 351; (1935), 229; (b) Rule and Dunbar, *J. Chem. Soc.* (1935), 1043; (c) Beckmann and Cohen, *J. Chem. Physics* **4** (1936), 784.
- ⁴ *Ber.* **72B** (1939), 1354.
- ⁵ *J. Am. Pharm. Assocn.* **29** (1940), 171.
- ⁶ *Arch. intern. pharmacodynamie* **63** (1939), 43.
- ⁷ *Quart. J. Pharm. & Pharmacol.* **15** (1942), 218.
- ⁸ *J. Chem. Soc.* (1927), 1279.
- ⁹ *Bull. soc. chim.* [4], **25** (1919), 479.
- ¹⁰ *J. Chem. Soc.* (1934), 315.
- ¹¹ *Compt. rend.* **140** (1905), 1301.
- ¹² *Ber.* **59B** (1926), 2298.
- ¹³ *Compt. rend.* **179** (1924), 405.
- ¹⁴ *J. Chem. Soc.* **101** (1912), 109.
- ¹⁵ *J. Soc. Chem. Ind.* **53** (1934), 52T.
- ¹⁶ *Ibid.* **60** (1941), 67T.
- ¹⁷ *J. prakt. Chem.* [2], **63** (1901), 61.
- ¹⁸ *Ibid.* [2], **55** (1897), 18, 30.
- ¹⁹ *Ind. Eng. Chem.* **36** (1944), 85.
- ²⁰ *Liebigs Ann.* **537** (1939), 113, 128.
- ²¹ *J. Chem. Soc.* (1933), 167.
- ²² *Biochem. J.* **34** (1940), 693.
- ²³ *Quart. J. Pharm. & Pharmacol.* **15** (1942), 218.
- ²⁴ "Die Ätherischen Öle," 3d Ed., Vol. I, 470.
- ²⁵ *J. Soc. Chem. Ind.* **51** (1932), 329T.
- ²⁶ *J. Chem. Soc.* (1933), 170.
- ²⁷ *Ibid.* (1927), 1280.
- ²⁸ *Ber.* **71B** (1938), 9.
- ²⁹ *J. Chem. Soc.* (1934), 317.
- ³⁰ *Rec. trav. chim.* **52** (1933), 974.
- ³¹ *Ber. Schimmel & Co.* (1934), 97.

- ³³ *Z. physik. Chem. Abt. B*, **30** (1935), 440.
³⁴ *J. prakt. Chem.* **149** (1937), 81.
³⁵ *Ber.* **72B** (1939), 1354.
³⁶ *Biochem. J.* **33** (1939), 1519.
³⁷ *J. Am. Chem. Soc.* **63** (1941), 120.
³⁸ *Ibid.* **63** (1941), 3251.
³⁹ *J. Chem. Soc.* **107** (1915), 46.
⁴⁰ *J. Am. Chem. Soc.* **39** (1917), 1517.
⁴⁰ Huggett, *Quart. J. Pharm. & Pharmacol.* **15** (1942), 226.

l-Menthol

C₁₀H₂₀O

Mol. Weight 156.26

Occurrence.—This most important of all menthols occurs in oil of peppermint (*Mentha piperita*) (50–65 per cent), and Japanese mint oil (*Mentha arvensis*) (75–90 per cent); small quantities have been found in a few other volatile oils, and traces in Réunion geranium oil, etc.

Isolation.—The most suitable starting material for the isolation of natural *l*-menthol is oil of *Mentha arvensis*. The oil is cooled to +15° and the menthol crystals are centrifuged off the liquid oil. The latter is then cooled to +5° and the crystals again removed by centrifuging. The process is repeated a third time at –10°. Starting from a natural oil containing about 85% *l*-menthol, the residual oil, after the third treatment, will still contain from 40 to 50% natural *l*-menthol and some menthone. According to Beckmann,¹ this ketone can be removed from the mixture by conversion into its oxime and by extracting the oxime from the ethereal solution through shaking with dilute sulfuric acid. The *l*-menthol will be obtained in solid form. The menthone may be reduced by various chemical means to several stereoisomers of menthol.

Where the isolation is carried out from synthetic mixtures of the isomeric menthols, or optically pure samples are desired, the techniques employed are the subject of many patents. However, a few of the published methods are apparently superior. Earlier directions were dependent on the use of acid phthalates and succinates, as introduced by Pickard and Littlebury,² but improved separative reagents are now in use. Recently Puetzer and Moran³ reported that pure *l*-menthol can be obtained in an overall yield of 61% of the theoretical from *dl*-menthol by employing *l*-ephedrine as the resolving agent for the acid succinates. Read et al.⁴ recommend the fractional crystallization of the *l*-menthyl esters of the *d*-camphor-10-sulfonic acid as an effective means of isolating *l*-menthol from *d*-menthol or from *d*- or *l*-isomenthols. When neo compounds are a contaminant, conversion to and separation of the menthyl esters of: (1) menthoxyacetic⁵ and (2) nitrobenzoic acids⁶ will permit most successful separation. The presence of the neo compounds is detected, according to Read and Grubb,⁷ by the use of Huggett's⁸ menthol-phosphoric acid complex [(C₁₀H₂₀O)₃ H₃PO₄] combined with *p*-nitrobenzoate recrystallization. Hückel and Niggemeyer⁹ use a combination of nitro- and aminobenzoates to advantage.

Identification.—Numerous derivatives of *l*-menthol have been reported in the literature but of other stereoisomers in the menthol series only a limited number of derivatives has so far been investigated. Since the physical properties of many of these compounds resemble one another closely, however, the constants of any derivative used for purposes of identification must be most accurately defined.

Among the many compounds of diagnostic value cited previously in the property tables of the menthols, those generally preferred for differential identification are: (1) 3,5-dinitrobenzoate, (2) *p*-nitrobenzoate, (3) phosphoric acid complex, (4) menthoxy acetate, (5) *d*-camphor sulfonate and (6) acid phthalate.

Regarding the quantitative determination of menthol, see Vol. I, Chapter 4, "The Examination and Analysis of Essential Oils, Synthetics, and Isolates."

Properties.—*l*-Menthol possesses a powerful peppermint-like odor and a cooling taste. Natural *l*-menthol crystallizes in hexagonal needles or prisms.

The following characteristic properties are reported by Zeitschel and Schmidt,¹⁰ Power and Kleber,¹¹ Long,¹² Gildemeister and Hoffmann,¹³ Beckmann,¹⁴ Hückel and Reimer,¹⁵ Huggett,¹⁶ and Kenyon and Pickard:¹⁷

m.	42°–43° ^{10,12,13,14}	$[\alpha]_D^{46}$	–49° 52' ¹² (fused)
b.	216° ¹⁰	$[\alpha]_D^{20}$	–49° 21' ¹⁴ (in 20% alcoholic solution)
b ₇₅₈	215.5° ¹¹	$[\alpha]_D^{20}$	–50° 35' ¹⁴ (in 10% alcoholic solution)
b ₇₄₂	212.5° ¹²	n_D^{60}	1.4461 ¹⁶
d _{81.4}	0.8523 ¹⁵	n_D^{20}	1.46096 ¹⁰
d ₆₂	0.8682 ¹⁵		
d ₃₀	0.8911 ¹⁶		
d ₄ ²⁰	0.9007 ¹⁷		

Menthol, a saturated secondary alcohol, can be converted by dehydrating agents (potassium bisulfate, zinc chloride, boiling with very dilute sulfuric acid, etc.), into 3-*p*-menthene, C₁₀H₁₈, b. 165–168°.

According to Beckmann,¹⁸ oxidation with chromic-sulfuric acid mixture yields almost quantitatively the corresponding *l*-menthone, whereby practically no conversion occurs. This reaction is used to advantage as the basis for the micro method of Ullrich and Schneider.¹⁹ When oxidizing menthol with potassium permanganate in acid solution, Arth²⁰ observed degradation to several low fatty acids together with *l*-ketonic acid and probably β -methyladipic acid m. 86°–87.5°.

Use.—Menthol is employed widely in pharmaceutical preparations where it serves as a local anesthetic, as a relief for headache, and as an antiseptic of the respiratory tract. It is also used in tooth pastes, mouth washes, and similar oral preparations. Menthol also serves for the flavoring of candies and chewing gums, and for the flavoring of certain brands of cigarettes.

¹ *J. prakt. Chem.* [2], **55** (1897), 17.

² *J. Chem. Soc.* **101** (1912), 109.

³ *J. Am. Pharm. Asscn.* **35** (1946), 127.

⁴ *J. Chem. Soc.* (1933), 170.

⁵ Read and Grubb, *J. Soc. Chem. Ind.* **51** (1932), 329T. Cf. British Patent No. 397,212, August 24, 1933.

- ⁶ Read and Grubb, *J. Chem. Soc.* (1933), 167.
⁷ *Ibid.* (1934), 313. Blagden and Huggett, *ibid.*, 317.
⁸ *Quart. J. Pharm. & Pharmacol.* **15** (1942), 218. *J. Chem. Soc.* (1934), 317.
⁹ *Ber.* **72B** (1939), 1354.
¹⁰ *Ber.* **59** (1926), 2302.
¹¹ *Pharm. Rundschau*, New York, **12** (1894), 162. *Arch. Pharm.* **232** (1894), 647.
¹² *J. Am. Chem. Soc.* **14** (1892), 149.
¹³ "Die Ätherischen Öle," 3d Ed., Vol. I, 469.
¹⁴ *Liebigs Ann.* **250** (1889), 327. *J. prakt. Chem.* II, **55** (1897), 15.
¹⁵ *J. prakt. Chem.* **149** (1937), 81.
¹⁶ *Quart. J. Pharm. & Pharmacol.* **15** (1942), 218.
¹⁷ *J. Chem. Soc.* **107** (1915), 46.
¹⁸ *Liebigs Ann.* **250** (1889), 325.
¹⁹ *Z. physiol. Chem.* **245** (1937), 181.
²⁰ *Ann. chim.* [6], **7** (1886), 456.

SUGGESTED ADDITIONAL LITERATURE

- Y. R. Naves, "Production of Synthetic Menthols," *Mfg. Chemist* **17** (1946), 525.
 Wallace R. Brode and Robert W. van Dolah, "Synthesis of Racemic Menthol,"
Ind. Eng. Chem. **39**, No. 9 (1947), 1157.
 Y. R. Naves and U. Korpi, "Sur la Polymorphie de l'Oxalate de *d,l*-Menthyle,"
Helv. Chim. Acta **30**, No. 5 (1947), 1219.

Neomenthol

C₁₀H₂₀O

Mol. Weight 156.26

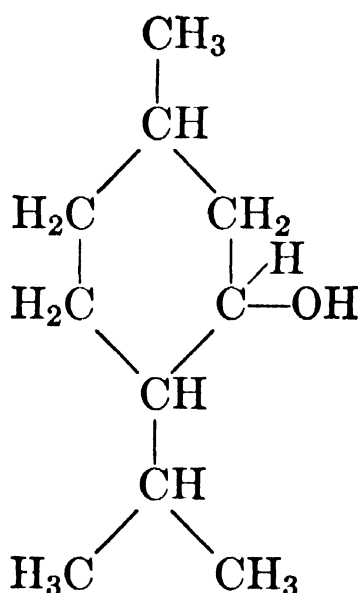
3-*p*-Menthanol. 1-Methyl-4-isopropylcyclohexan-3-ol.

Occurrence.—Pickard and Littlebury¹ found small quantities of *d*-neomenthol in oil of *Mentha arvensis*. *d*-Neomenthol, a liquid at room temperature, remains in the dementholized oil after *l*-menthol has been partly removed by freezing (see "*l*-Menthol").

Isolation.—By fractional distillation and as acid phthalate m. 142°–144°.

An improved procedure, if optically pure isolates are desired, is that of Read and Grubb,^{2,3} who prepared the menthoxy esters by reaction with *d*- or *l*-menthoxy acetyl chloride in pyridine. The purified neomenthols are regenerated, the *p*-nitrobenzoates prepared and fractionally recrystallized. This process yields highly pure compounds.

Details regarding this separative process of fractional-distillation, -crystallization, -saponification will be found in British Patent No. 297,019 (re: fractional esterification) and German Patent No. 568,085 (1926) (re: fractional recrystallization and saponification).

Identification.—Neomenthol may be characterized by many derivatives, several of which are summarized in the following table: (Hückel and Tappe,⁴ Williams,⁵ Read and Grubb,^{6,7} and Pickard and Littlebury⁸).

	<i>d</i>	<i>l</i>	<i>dl</i>
<i>p</i> -Toluene sulfonate ⁴	m. 63° [α] _D +19° 48'		
3,5-Dinitrobenzoate ^{5,6}	m. 155° [α] _D ²² +23° 36' (c = 0.9 in CHCl ₃)	m. 153° [α] _D ¹³ -23° 54' (in CHCl ₃)	m. 130°
Acid phthalate ⁸	m. 142°–144° [α] _D +68° 42' (in CHCl ₃) Brucine salt: m. 125°–127°		m. 175°–177° Mg salt I m. 82° II m. 135°
<i>p</i> -NO ₂ benzoate ^{7,6}	m. 94.5°–95° [α] _D ¹⁵ +17° 48' (in CHCl ₃)	m. 95° [α] _D ¹³ -17° 54' (in CHCl ₃)	m. 78.5°
Phenylurethane ⁸		m. 107°–108° [α] _D -26° 46' (in CHCl ₃)	m. 114°

Properties.—Neomenthol is a liquid possessing a menthol-like odor. The following properties of this alcohol in one or more of its stereoisomeric forms have been reported by Grubb and Read,⁹ Haller and Martine,¹⁰ Kondakov and Bachtschiev,¹¹ Beckmann,¹² Pickard and Littlebury,¹³ Zeitschel and Schmidt,¹⁴ Huggett,¹⁵ Vavon and Couderc¹⁶ and Barney and Hass.¹⁷ However, those recently observed by Read and Grubb⁹ for the *d*- compound were obtained on an optically pure sample and should thus be characteristic:

d-Neomenthol

m.	-22° ⁹	α_D^{16}	$+17^{\circ} 48'$ (in alc.) ⁹
b.	212° – 212.5° ^{10,14}	$[\alpha]_D^{20}$	$+20^{\circ} 0'$ (in alc.) ¹⁵
b ₂₀	107° – 108° ¹⁶	$[\alpha]_D^{18}$	$+19^{\circ} 41'$ ¹³
b ₁₆	98° ¹³	n_D^{60}	1.4448 ⁹
b ₈	87° ⁹		1.4450 ¹⁵
d ₃₀	0.8917 ¹⁵ (supercooled)	n_D^{20-22}	1.4594–1.4603 ^{14,15,16}
d ₄ ²²	0.8970 ¹⁶	n_D^{17}	1.4617 ⁹
d ₁₅ ¹⁵	0.903 ¹⁴		

l-Neomenthol

b ₂₁	105° ¹³	$[\alpha]_D^{18}$	$-19^{\circ} 37'$ ¹³
b ₁₀	97.6° ⁹	$[\alpha]_D^{17}$	$-20^{\circ} 42'$ (in alc.) ⁹
d ₄ ²⁰	0.8995 ¹³	n_D^{20}	1.4603 ¹³
d ₄ ⁰	0.9124 ¹³	n_D^{12}	1.4638 ⁹

dl-Neomenthol

m.	50° – 52° ^{12,13,14,15,17}	d ₃₀	0.8917 ¹⁵
b ₇₅₃	211.4° – 211.8° ¹⁴	d ₂₀ ²⁰	0.9052 ¹¹
b ₁₆	103° – 105° ¹³	n_D^{60}	1.4450 ¹⁵
b ₁₂	98° – 100° ¹¹	n_D^{20}	1.4600 ¹⁵ (supercooled)
		n_D	1.4645 ¹¹

Use.—*d*-Neomenthol is used in mixtures of menthol isomers which serve as substitutes for *l*-menthol.

¹ *J. Chem. Soc.* **101** (1912), 109–27.

² *Ibid.* (1933), 167.

³ *J. Soc. Chem. Ind.* **53** (1934), 52T; **51** (1932), 329T.

⁴ *Liebigs Ann.* **537** (1939), 128.

⁵ *Biochem. J.* **34** (1940), 694.

⁶ *J. Chem. Soc.* (1933), 167.

⁷ *J. Soc. Chem. Ind.* **53** (1934), 52T.

⁸ *J. Chem. Soc.* **101** (1912), 123.

⁹ *J. Soc. Chem. Ind.* **53** (1934), 52T. *J. Chem. Soc.* (1933), 167.

¹⁰ *Compt. rend.* **140** (1905), 1301.

¹¹ *J. prakt. Chem.* [2], **63** (1901), 61.

¹² *Ibid.* [2], **55** (1897), 30.

¹³ *J. Chem. Soc.* **101** (1912), 122.

¹⁴ *Ber.* **59B** (1926), 2298.

¹⁵ *J. Soc. Chem. Ind.* **60** (1941), 67T.

¹⁶ *Compt. rend.* **179** (1924), 405.

¹⁷ *Ind. Eng. Chem.* **36** (1944), 85.

(b) BICYCLIC TERPENE ALCOHOLS.

The Santenols

 $C_9H_{16}O$

Mol. Weight 140.22

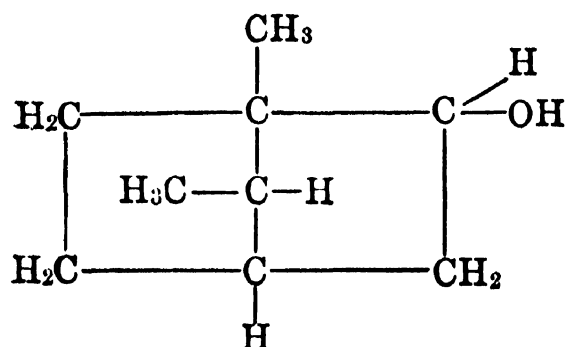

Years ago Schimmel & Co.¹ isolated from East Indian sandalwood oil a bicyclic terpene alcohol $C_9H_{16}O$, m. 58° – 62° which they named santenone alcohol since, on oxidation with chromic acid, it yielded santenone. As the constitution of this ketone (see "Santenone") is well established, the santenone alcohol occurring in East Indian sandalwood oil most probably has the structural formula pictured above.

A number of synthetic hydroxy terpenes² that are isomeric with this "santenone alcohol" have been described in the literature since the original investigation by Schimmel & Co. of the natural hydroxy compound $C_9H_{16}O$ from sandalwood. Nevertheless the exact structural relationship between these many products remains unclarified and, as a consequence, the nomenclature is in a most confused state. The laboratory "santenols" will be found in various publications under several names, as π -norborneol, π -norisoborneol, α -santenol, β -santenol, γ -santenol, and santene hydrate with melting points varying from 58° – 106° . Thus the recommendation of Simonsen³ to maintain the name "santenone alcohol" as applicable alone to the natural isolate seems most logical and should apply until such time as a uniform system of nomenclature is accepted in this series or its exact relationship to a properly identified synthetic is established.

Occurrence.—Santenone alcohol has been obtained from East Indian sandalwood oil.

Isolation.—The fraction b₉ 76° – 90° of East Indian sandalwood oil is freed from santenone and boiled with concentrated formic acid. The alcohol set free by saponification is heated with phthalic anhydride to 140° and the hydroxy compound subsequently regenerated.

Although there is no certainty as to the stereochemical relationship, Komppa,⁴ when investigating the synthetic "santenols," found the use of diphenic anhydride to be a method of isolation superior to that of the phthalic technique of Schimmel & Co.⁵ recommended above.

Identification.—On oxidation with chromic acid, the natural santenol yields a santenone, according to Schimmel & Co., which can readily be characterized by the preparation of a semicarbazone m. 223° – 225° (see also Ishidate and Sano⁶ and Komppa and Nyman⁷ regarding other santenone semicarbazones).

Properties.—The santenols possess an odor resembling that of borneol.

As mentioned previously, the melting points of the several "santenols" reported in the literature show considerable variations, caused probably by incomplete purifications or more likely by the formation of stereoisomers in the particular method used. The naturally occurring hydroxy terpene (santenone alcohol) melts at 58°–62°. However nothing is known as to its purity; it boils at 196°–198°. Komppa⁸ purified the synthetic santenol referred to above (obtained through hydration of santene) by the preparation of crystalline santenyl acid diphenate m. 119°–120°, and by hydrolysis of this compound. The santenol thus obtained melted at 86°.

On oxidation with potassium permanganate in alkaline solution, a santenol readily yields a santenic acid m. 170°–171°. The anhydride of this acid melts at 115°–116°, according to Komppa and Hintikka.⁹

Use.—The santenols as such are not used in our industries.

¹ *Ber. Schimmel & Co.*, Oct. (1910), 100.

² In connection with this subject consult: (a) Semmler and Bartelt, *Ber.* **40** (1907), 4467; **41** (1908), 128. (b) Aschan, *Ber.* **40** (1907), 4923. (c) Diels and Alder, *Liebigs Ann.* **486** (1931), 202. (d) Komppa and Beckman, *Liebigs Ann.* **522** (1936), 137. (e) Komppa and Nyman, *Ann. Acad. Sci. Fennicae* **A45**, No. 1 (1935). *Chem. Abstracts* **31** (1937), 6644.

³ "The Terpenes," Vol. II (1932), 213.

⁴ *Ber.* **62** (1929), 1751.

⁵ *Ber. Schimmel & Co.*, Oct. (1910), 100.

⁶ *Ber.* **74B** (1941), 1189.

⁷ *Ann. Acad. Sci. Fennicae* **A45**, No. 1 (1935). *Chem. Abstracts* **31** (1937), 6644.

⁸ *Ber.* **62** (1929), 1751.

⁹ *Bull. soc. chim.* [4], **21** (1917), 17.

C₁₀H₁₆O

Sabinol

Mol. Weight 152.23

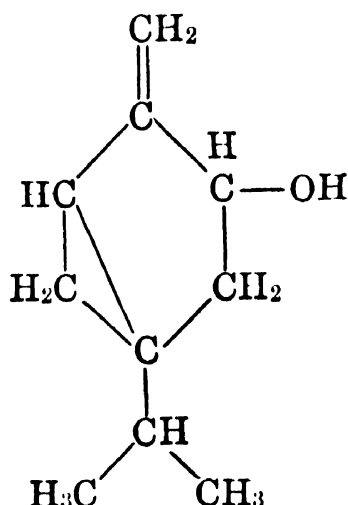

Occurrence.—*d*-Sabinol occurs free and as acetate in oil of savin (*Juniperus sabina* L.), probably also in cypress oil. The sabinol isolated by Paolini and Reborà¹ from savin oil was homogeneous.

Isolation.—Sabinol can be isolated by saponification of savin oil with potassium hydroxide in alcoholic solution, by steam distillation, and fractionation of the steam distillate.

Identification.—Sabinol may be characterized by several reactions:

(1) According to Semmler² and Fromm,³ sabinol on oxidation with cold dilute potassium permanganate solution yields sabina glycerol m. 152°–153° which, on further oxidation, gives α -thujadicarboxylic acid m. 140°–142°.

(2) By the preparation of the *p*-nitrobenzoate m. 76°.

(3) By the preparation of the crystalline acid phthalate m. 94°–95°, according to Paolini and Rebora.⁴

(4) Wallach⁵ found that on treatment of sabinol (in alcoholic solution) with sulfur dioxide, a sulfonic acid C₁₀H₁₅SO₃H, m. 98°–99° is obtained.

Properties.—*d*-Sabinol is an oil of faint, agreeable odor.

d-Sabinol purified through its crystalline acid phthalate had these typical properties:

b.	208°	$[\alpha]_D$	+7° 56'
d_{15}^{15}	0.9518	n_D^{18}	1.4895

Sabinol shows a marked exaltation of the refractive index (+1.5).

Fromm⁶ found that the action of halogen acids on sabinol causes ring fission and dehydrogenation to *p*-cymene. According to Wallach,⁷ ring fission also occurs when sabinol is shaken with a 5 per cent sulfuric acid solution, 1-*p*-menthene-4,6-diol being thereby formed.

Use.—Sabinol, as such, is not used in our industries.

¹ *Atti. accad. Lincei* [5], **25** (1916), [2], 377.

² *Ber.* **33** (1900), 1459.

³ *Ber.* **31** (1898), 2030.

⁴ *Atti. accad. Lincei* [5], **25** (1916), [2], 380.

⁵ *Nachr. Ges. Wiss. Gottingen* **3** (1919), 321. *Ber. Schimmel & Co.* (1920), 143.

⁶ *Ber.* **31** (1898), 2030; **33** (1900), 1208.

⁷ *Liebigs Ann.* **360** (1908), 99.

SUGGESTED ADDITIONAL LITERATURE

Harry Schmidt, "Rearrangement of Pinocarveol and of Sabinol," *Ber.* **62B** (1929), 103.

C₁₀H₁₆O

Pinocarveol

Mol. Weight 152.23

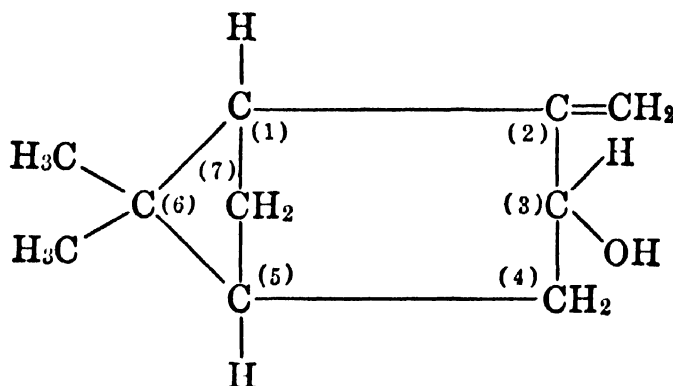

Occurrence.—The laevorotatory form of this bicyclic secondary alcohol occurs in the high boiling fractions of *Eucalyptus globulus* oil.

CHARACTERISTICS OF PINOCARVEOLS

Stereo Form	Source	Resultant on Oxidation	b. °C.	m. °C.	d_4^t	α_D	n_D^{20}	m. °C. Derivatives for Pure Isomer
<i>trans</i>	Oxidation of <i>l</i> - β -pinene with Co siccative ⁷	with CrO ₃ ⁸ <i>d</i> -pinocarvone	b ₇₅₀ 208–209 ⁷	7 ⁷	d^{20} 0.9815 ⁷	+59° 0' ⁷	1.49931 ⁷	(1) Dimol hydrate (C ₁₀ H ₁₈ O ₂) ₂ m. 196° ⁹ (2) Dimol bromide (C ₁₀ H ₁₆ OBr) ₂ m. 160° ⁶
	Oxidation of β -pinene with selenious acid ¹⁰	...	b ₂₀ 101–102 ¹⁰	~5 ¹¹	$d_{20}^{20.5}$ 0.9798 ¹⁰	α_D^{20} +67° 29' ¹⁰	1.49950 ¹⁰	(3) Phenylurethane m. 99°–100° (?) ⁸ M _D 45.67 ⁹ EM _D +0.64 ⁹
	<i>l</i> <i>Eucalyptus globulus</i> oil ^{8,9}	with CrO ₃ ⁸ <i>l</i> -pinocarvone	b ₇₆₀ 209–210 ⁹	~5 ⁹	0.981 ⁹	–72° 0' ⁹ (in 5% alc.)	1.50054 ⁹	M _D 45.01 ⁹ EM _D –0.02 ⁹ (1) Fails to form dimolecular hydrate. ⁹ (2) Fails to form dimolecular bromide ⁹ (3) Phenylurethane liquid. ⁸ (4) α -Naphthylurethane liquid. ⁸ (5) Fails to form solid phthalate. ⁹ (6) <i>p</i> -NO ₂ benzoate m. 104° ⁹
<i>cis</i>	Reduction of <i>l</i> -pinocarvone from <i>Eucalyptus globulus</i> by Al(OPr) ₃ ⁸ and Zn + AcOH on pinocarvone dibromide ⁹ "isopinocarveol"	with CrO ₃ ⁸ <i>l</i> -pinocarvone	b ₇₆₀ 217–218 ⁹ b ₇ 92–93 ⁸	50–51 ^{8,9}	d^{20} 1.004 ⁹	+55° 0' ⁹ (in 5% alc.)	1.50568 ⁹	
	This stereo form has not yet been recognized.							

Isolation.—(1) Schmidt¹ recommends the isolation of pinocarveol by successive treatment with boric acid and phenyl thiocyanate. This method, according to the author, is an improvement over the phthalic ester method of Wallach,² and permits the isolation of pinocarveol from the various products obtained either by the autoxidation of β -pinene, or by the reduction of pinocarpone with aluminum tri-isopropylate.

Identification and Properties.—The naturally occurring pinocarveol is a syrupy oil with a terpene-like, pleasant odor, if the product is pure. Schmidt³ has devoted particular attention to a study of the pinocarveols and classified the natural isolates, as well as the synthetic products. These data are summarized above to emphasize and clarify the relations in the several products. The natural laevorotatory product is described as very pure. No consideration will be given to the properties of the *dl*-form, as the data originally gathered on this racemate and its derivatives by Wallach⁴ and Schmidt⁵ are not beyond question in view of recent research on the properties of the active forms. Schmidt,^{6,7,8,9} Joshel and Palkin,¹⁰ and Stallcup and Hawkins¹¹ reported the characteristics tabulated on page 232.

Use.—Pinocarveol, as such, is not used in our industries.

¹ *Ber.* **62** (1929), 2945; **63** (1930), 1129.

² *Liebigs Ann.* **346** (1906), 227.

³ *Ber.* **62** (1929), 2945; **63** (1930), 1129; **77B** (1944), 167. *Ber. Schimmel & Co.* (1941), 56.

⁴ *Liebigs Ann.* **277** (1893), 149.

⁵ *Ber.* **63** (1930), 1131.

⁶ *Ber.* **62** (1929), 2945.

⁷ *Ber.* **63** (1930), 1129.

⁸ *Ber. Schimmel & Co.* (1941), 56. *Chem. Abstracts* **37** (1943), 4714.

⁹ *Ber.* **77** (1944), 167.

¹⁰ *J. Am. Chem. Soc.* **64** (1942), 1008.

¹¹ *Ibid.*, 1807.

Myrtenol

$C_{10}H_{16}O$

Mol. Weight 152.23

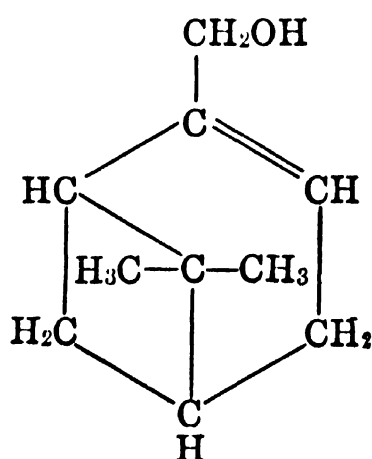

Occurrence.—The dextrorotatory form of this primary, unsaturated, bicyclic alcohol was found by von Soden and Elze¹ to occur mainly as acetate in myrtle oil distilled from the leaves and flowers of *Myrtus communis* L. The *d*-form has been identified also in the last runs of Spanish eucalyptus oil (*E. globulus*). Laevorotatory myrtenol is present in myrtle oil of Spanish origin.

Isolation.—Myrtenol may be isolated by saponifying the higher boiling fractions of myrtle oil with alcoholic alkali and by treating these fractions with phthalic anhydride whereby the crystalline acid phthalate is readily formed. From the latter the alcohol can be regenerated in pure form by hydrolysis with alkali.

Identification.—Von Soden and Elze,² Paolini,³ Dupont and collaborators,⁴ Penfold, Ramage and Simonsen,⁵ and Schmidt⁶ identified myrtenol among its several isomeric forms by a number of crystalline derivatives.

(1) By the preparation of the acid phthalate which has been reported for the

		<i>d-isomer</i>	
m.	116° ²	[α] _D	+21° 15' (in alcohol) ⁴
	115°–116° ³		+21° 22' (in alcohol) ⁴
	113.5°–114.5° ⁴		
	111°–113° ⁵		
	114°–115° ^{4,6}		

		<i>dl-isomer</i>
m.		120°–120.5° ⁴

(2) By the preparation of the phenylurethane

		<i>d-isomer</i>
m.		58°–59° ⁵

(3) By the preparation of the α-naphthylurethane

<i>d-isomer</i>		<i>l-isomer</i>	
m.	92°–93° ⁵	m.	92°–93° ⁶

(4) By oxidation of the alcohol with chromic acid to *d*-myrtenal. This aldehyde can be characterized by the preparation of several derivatives—for example, the semicarbazone m. 230°, and the oxime m. 71°–72° (see “Myrtenal”).

Properties.—The properties of myrtenol have been variously reported by several authors. Paolini⁷ suggests these differences as due to hitherto unrecognized isomers. Dupont and Zacharewicz⁸ prepared myrtenols from pinenes, and observed that this process is further complicated by the presence of geometric isomers. In spite of the varying sources of material, the data of these authors would appear to confirm the earlier findings of Semmler and Bartelt⁹ who prepared a *d*-myrtenol (purified through its acid phthalate) with these properties:

b.	222°–224°	d ₂₀	0.9763
b ₉	102.5°	α _D	+45° 45'
		n _D	1.49668

Von Soden and Elze¹⁰ reported a *d*-myrtenol isolated from myrtle oil as follows:

b ₇₅₁	220°–221°	d ₁₅	0.985
b _{3.5}	79.5°–80°	α _D	+49° 25'

Paolini ¹¹ found for *l*-myrtenol occurring in Spanish myrtle oil:

b.	220°
d ₁₅	0.981
[α] _D	−3° 50′

Schmidt ¹² obtained a *l*-myrtenol by the oxidation of pinene in the presence of cobalt siccativ; this isomer had the following properties:

b.	221°–222°	α _D	−46° 16′
d ₁₅	0.985	n _D	1.49677

Meager information is at hand on the inactive form of this terpene alcohol prepared by Dupont, Zacharewicz and Dulou ¹³ who found:

d ₀	0.9849
n _D ²⁰	1.4963

Use.—Myrtenol, as such, is not used in our industries.

SUGGESTED ADDITIONAL LITERATURE

H. Rupe and Alwin Héritier, "Influence of the Constitution upon the Optical Activity of Optically Active Substances. Optically Active Myrtenyl Derivatives," *Liebigs Ann.* **459** (1927), 171. *Chem. Abstracts* **22** (1928), 1575.

¹ *Chem. Ztg.* **29** (1905), 1031.

² *Ibid.*

³ *Gazz. chim. ital.* **63** (1933), 666.

⁴ *Bull. soc. chim.* [5], **2** (1935), 533. See also *Compt. rend.* **198** (1934), 1699.

⁵ *J. Proc. Roy. Soc. N. S. Wales* **68** (1934), 36.

⁶ *Ber. Schimmel & Co.* (1941), 56, 70. *Chem. Abstracts* **37** (1943), 4714, 4715.

⁷ *Gazz. chim. ital.* **63** (1933), 666.

⁸ *Bull. soc. chim.* [5], **2** (1935), 533. See also *Compt. rend.* **198** (1934), 1699.

⁹ *Ber.* **40** (1907), 1366.

¹⁰ *Chem. Ztg.* **29** (1905), 1031.

¹¹ *Gazz. chim. ital.* **63** (1933), 666.

¹² *Ber. Schimmel & Co.* (1941), 70. *Chem. Abstracts* **37** (1943), 4716.

¹³ *Compt. rend.* **198** (1934), 1699.

$C_{10}H_{16}O$

Verbenol

Mol. Weight 152.23

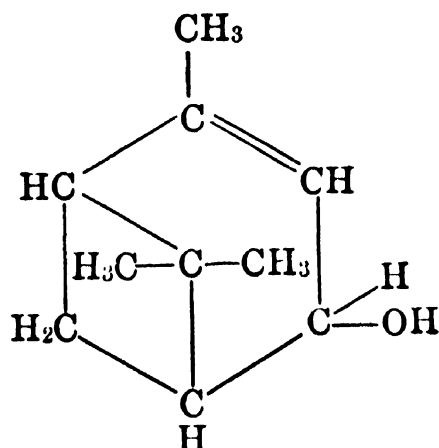

Occurrence.—This unsaturated, bicyclic alcohol occurs in the volatile oil distilled from the gum resin of olibanum (*Boswellia Carteri*).

Isolation.—The alcohol $C_{10}H_{16}O$, a natural isolate, was originally called olibanol, but Blumann and Schulz¹ later showed it to be a mixture of *d*-verbenone and *d*-verbenol. The latter could not at that time be obtained in pure form, due to experimental difficulties. However, more recently, the Raman spectra have served in preparatory work (cf. Dupont and Zacharevicz²) to assure the purity of closely related compounds such as the above, and have thus eliminated much of the confusion surrounding the isolation and structural determinations of products derived from, and isomeric with, verbenol.

Identification.—Schmidt, Schulz and Doll³ prepared the *p*-nitrobenzoates from the *cis*- and *trans*- isomers of *d*-verbenol. From the compound which they described as the highly purified *trans*- isomer, they obtained a *p*-nitrobenzoate m. 83.5° – 84° , $[\alpha]_D +197^{\circ} 0'$ (in 10% benzene solution). The compound which they assumed to be the *cis*- isomer, according to the Auwers-Skita rule (obtained in a purity of about 90%), yielded a *p*-nitrobenzoate m. 98° – 99° , $[\alpha]_D +14^{\circ} 0'$ (in 10% benzene solution).

Properties.—The various physical properties reported for verbenol may be attributed to the nonhomogeneous character of the isolates obtained from several different sources by Blumann et al.,⁴ Suzuki,⁵ and Schmidt, Schulz and Doll.⁶ These latter authors, however, prepared two isomeric forms of verbenol and obtained derivatives thereof. The properties reported by Schmidt et al. are enumerated below. The compound which they assumed to be the *trans*- isomer was prepared from turpentine oil by air oxidation in the presence

<i>Trans</i> -		<i>Cis</i> -	
cong. pt.	24.0°	cong. pt.	15.5°
b_{10}	92°	b_{10}	90°
d_4^{25}	0.9657	d_{20}	0.9724
$[\alpha]_D$	$+168^{\circ} 45'$	d_4^{25}	0.9684
n_D^{25}	1.49078	$[\alpha]_D$	$+65^{\circ} 30'$
		n_D^{25}	1.49120
		n_D^{20}	1.49320

of cobalt siccative. The *cis*- isomer (only about 90 per cent pure) was derived by reduction of verbenone with aluminum isopropylate and isopropyl alcohol.

Blumann and Zeitschel ⁷ described a laevorotatory isomer b_{12} 100° – 104° , derived from French turpentine oil.

Use.—Verbenol is not used in our industries.

¹ *Liebigs Ann.* **478** (1930), 303.

² *Bull. soc. chim.* [5], **2** (1935), 533.

³ *Ber. Schimmel & Co.* (1940), 38. *Chem. Zentr.* II (1940), 3037. Cf. Schulz and Doll, *Ber. Schimmel & Co.* (1942–43), 50.

⁴ *Liebigs Ann.* **453** (1927), 48. See also *Ber.* **46** (1913), 1195.

⁵ *Bull. Inst. Phys. Chem. Research Tokyo* **14**, 179. *Sci. Papers Inst. Phys. Chem. Research Tokyo* **26**, Nos. 560–565 (1935), 14.

⁶ *Ber. Schimmel & Co.* (1940), 38. *Chem. Zentr.* II (1940), 3037. Cf. Schulz and Doll, *Ber. Schimmel & Co.* (1942–43), 50.

⁷ *Ber.* **46** (1913), 1198.

Pinocampheol

$C_{10}H_{18}O$

Mol. Weight 154.24

3-Pinanol

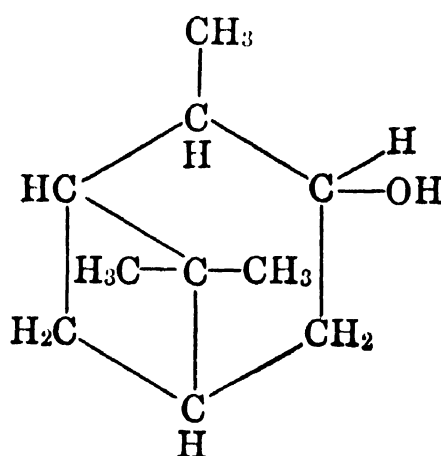

Occurrence.—Rutovskii and Vinogradova ¹ found the laevorotatory form of this bicyclic secondary alcohol to occur in oil of hyssop (*Hyssopus officinalis*).

Isolation.—By fractional distillation of oil of hyssop, preparation of the phenylurethane and regeneration of the alcohol.

Identification and Properties.—Rutovskii and Vinogradova ² reported for natural *l*-pinocampheol:

m.	56° – 57°	α_D	$-45^{\circ} 38'$
d_{20}	0.9509	n_D^{20}	1.4888

Studying the stereochemistry of pinocampheol, which is similar to that of the menthols, Schmidt and Schulz ³ reported the derivatives and properties given in the following table.

	m.	b.	d_{15}^{15} *	α_D^\dagger	n_D^{20}	Melting Points		
						Phenyl-urethane	Naphthyl-urethane	Phthalate
<i>cis-l</i> -Pinocampeol	57°	219°	0.973	-36°	...	liq.	88°	126°
<i>cis-d</i> -Pinocampeol	57°	219°	0.973	+37°	...	liq.	...	126°
<i>cis-dl</i> -Pinocampeol	42°	219°	0.973	$\pm 0^\circ$...	liq.
<i>trans-l</i> -Pinocampeol	67°	217°	0.968	-55°	1.48335	77°	91°	107°
<i>trans-d</i> -Pinocampeol	67°	217°	0.968	+55°	1.48330	77°
<i>trans-dl</i> -Pinocampeol	36°	217°	0.968	$\pm 0^\circ$...	99°	...	113°
Pinocampeol (Wallach ⁴)	liq.	218°-219°	...	$\pm 0^\circ$...	98°

* Determined in superfused state.

† For 20% solutions in alcohol.

Kuwata ⁵ in 1937 reported a number of properties on synthetic stereoisomers of this series. These are in every case, however, slightly variant from the *cis-trans* forms enumerated above. Thus it is possible that they are isomeric with and not identical with the pinocampeols of Schmidt, a possibility not overlooked in the publication of Kuwata.

Schmidt ⁶ also described a synthetic "neopinocampeol" diastereoisomeric with the *d*-, *l-trans* modifications found in the course of his earlier work.

Moreover the discovery that the pinocamphones assume dynamic equilibria under the influence of acids, alkalis and catalysts suggests the same possibility for the alcohols of this series. Such an assumption might account for the lack of uniformity in the properties of a number of these alcoholic isolates.

The organoleptic properties of the stereoisomeric pinocampeols vary—the *cis*- compounds resemble fenchol; the *trans*- isomers, borneol, according to Schmidt.⁷

Use.—Pinocampeol, as such, is not used in our industries.

¹ *Trans. Sci. Chem. Pharm. Inst. Moskow* **10** (1924), 22. *Chem. Abstracts* **23** (1929), 1717.

² *Ibid.*

³ *Ber. Schimmel & Co.* (1934), 99.

⁴ "Terpene und Campher," 2d Ed. (1914), 244.

⁵ *J. Am. Chem. Soc.* **59** (1937), 2509.

⁶ *Ber. Schimmel & Co.* (1940), 38. *Chem. Zentr.* II (1940), 3037.

⁷ *Ber. Schimmel & Co.* (1934), 93.

SUGGESTED ADDITIONAL LITERATURE

H. Schmidt, "Konfiguration der Stereoisomeren Pinocampeole," *Ber.* **77** (1944), 544. *Chem. Abstracts* **40** (1946), 5413.

H. Schmidt, "Pinocarvon und die beiden diastereomeren Pinocarveole," *Ber. Schimmel & Co.* (1944/47), 79.

Borneol

C₁₀H₁₈O

Mol. Weight 154.24

Bornyl alcohol. 2-Hydroxycamphane. 2-Camphanol

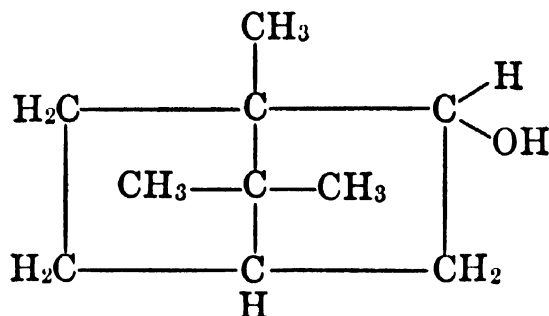

Borneol is one of the most important hydroxy compounds of the terpene series. Although it has been chemically known for nearly a century, studies still continue on the relationship existing between this bicyclic alcohol and its structural relative, isoborneol. Interest on the part of some recent workers has centered around the evidence for an endo-exo type of configuration to account for the isomerism between borneol and isoborneol:

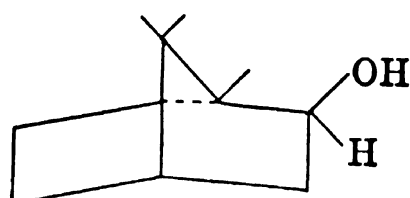

"Exo" structure

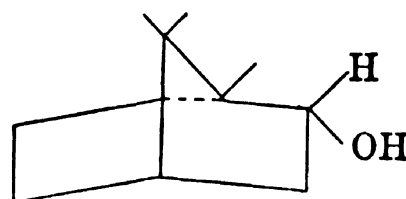

"Endo" structure

Investigations of others suggest that this isomerism is more fundamental than may be explained by a difference in configuration of the hydroxylated carbon atom.

A proper perspective of these recent views on the structural relations existing in the borneol-isoborneol series and their closely allied tautomers may be obtained in publications by Meerwein and van Emster,¹ Vavon and Peignier,² Hückel et al.,³ Lipp,⁴ Asahina and Ishidate,⁵ Komppa and Beckmann,⁶ Asahina, Ishidate and Sano,⁷ Krestinski and Eshchenko,⁸ Bartlett and Pöckel,⁹ and Yamada.¹⁰

Theoretical conclusions drawn from these investigations have greatly contributed to our present-day knowledge of terpene chemistry. New derivatives helpful in the identification and analysis of borneol and isoborneol have been developed, and physicochemical properties of highly purified isomers have been determined accurately.

Occurrence.—Borneol occurs in nature quite widely distributed as *d*- and *l*- modification, free and in ester form. When esterified, borneol is mostly laevorotatory.

d-Borneol ("borneo-camphor") forms the principal constituent (crystalline separation) of the oil from *Dryobalanops camphora*, *D. longifolia* and *D. be-*

carii, trees native to Sumatra and Borneo. *d*-Borneol also occurs in oil of nutmeg, olibanum, rosemary, lavender and spike-lavender, etc.

l-Borneol is present in the needle oil of *Abies concolor* and *Pinus palustris*, in oil of citronella, thuja, coriander, valerian root, Canadian snakeroot, in yellow pine oil, *Lippia adoensis* from Senegal, etc.

Borneol has also been identified in many other oils but no optical rotation was reported.

Bornyl acetate is an important constituent of several pine needle oils, for instance of *Abies alba*, *Pinus pumilio*, *Pinus sylvestris*, etc. Siberian pine needle oil contains 30–40 per cent of bornyl acetate.

Isolation.—Borneol can be isolated from Siberian pine needle oil, for example, by first saponifying the oil, removing the terpenes through distillation, and by cooling the borneol fraction b. 205°–215°. Most of the borneol will separate as a crystalline mass, and the borneol remaining liquid can be isolated as acid phthalate.

A mixture of borneol and camphor may be separated, according to the method suggested by Haller:¹¹

The mixture is heated for several hours with succinic anhydride, thereby converting the borneol into the acid succinate, the sodium salt of which is soluble in water and thus can readily be separated from the camphor. Instead of succinic anhydride, phthalic anhydride may be used. The benzoic and stearic esters of borneol, which can be prepared by heating the borneol with the corresponding anhydrides, are only sparingly volatile, which fact permits the separation of any camphor from these esters by simple steam distillation. On the other hand, the camphor may be converted into its oxime and the latter separated from the mixture by shaking with dilute (25%) sulfuric acid.

In order to determine the borneol in such a mixture quantitatively, a highly concentrated solution of the mixture in a suitable solvent such as xylene is acetylated, and the alcohol content calculated by the usual methods (see Vol. I, Chapter 4, "The Examination and Analysis of Essential Oils, Synthetics, and Isolates," p. 276).

In case a mixture contains borneol and isoborneol, the latter may be converted into camphene by heating with benzoic acid, benzoic anhydride or stearic acid, as well as several other dehydrating agents. The borneol can be regenerated by hydrolysis of its ester.¹²

Bertram and Walbaum¹³ showed that when a fraction containing borneol and isoborneol is heated for 15 to 30 min. with a mixture of 20% sulfuric acid and 80% methyl alcohol, only the isoborneol will be converted into the methyl ether.

As a convenient method of separating borneol from isoborneol, Tschugaev¹⁴ recommended preparing the methylbornylxanthate from which borneol can be regenerated by hydrolysis, while methylisobornylxanthate is dehydrated to camphene.

d- and *l*-Methylbornylxanthate m. 56°–57°, $[\alpha]_D +33^\circ 41'$ and $-33^\circ 23'$; *dl*- form m. 28.5°–29°.

For the purification of borneol and its separation from isoborneol, Pickard and Littlebury¹⁵ suggested this convenient method:

Digest the mixture with zinc chloride *in benzene solution*. The isoborneol will be dehydrated to camphene and is removed. Purify the borneol through its crystalline acid phthalate.

Yamada and Yamada¹⁶ recommended as the best method of separating borneol from isoborneol, that the mixtures of these alcohols be esterified with 4 mols of phthalic anhydride at 80°–85° for 25 hr. Ikeda and Fujita¹⁷ report that pure borneol is ob-

tained after processing with phthalic anhydride by extracting the reaction mixture with petroleum ether in which the phthalic acid ester is insoluble. Then dissolve the insoluble part in sodium hydroxide and steam distill. Melting point of *d*- or *l*-bornyl acid phthalate: 164.5°–165.5° (corr.).¹⁸ Ross and Somerville¹⁹ found that the racemic mixture depressed the melting point of the active form only a few degrees.

Several other methods have been suggested for this purpose. The reader will find literature references to a few of these at the end of this chapter, and others will be indicated in the section on derivatives as space does not permit considering all of them.

Identification.—Borneol can be characterized in many ways, the simplest being by fractionating the oil and cooling the fraction b. 205°–215°. The active borneol will, in most cases, separate in the form of crystals m. 203°–204°.

Frequently it will be necessary to identify borneol by the preparation of derivatives (many of which are described in the literature); it is, however, exceptional to find the properties of the same derivative pertaining to every single and individual stereoisomer of borneol. For this reason the bornoxy acetates, fumurates, tartrates, malonates and glucosides are generally of little practical use, although in isolated cases of certain stereoisomers they offer good possibilities both for isolation and identification.

In many cases it may be sufficient to differentiate between borneols and isoborneols in general, rather than to identify a particular stereoisomer within the groups. For this purpose quite a number of derivatives are available, but often their melting points are too close to be of much practical help. In this group belong the phenyl urethanes, the α -naphthyl urethanes, the acid phthalates, succinates, oxalates and formates.

Among the derivatives whose characteristics are both known and possess a wide melting point differential, those offering the most promise to distinguish isomers in both the borneol and isoborneol series are the nitrobenzoates, a number of which were recently reported by Hückel et al.,²⁰ also Asahina, Ishidate and Sano,²¹ and the α -naphthylamine addition products by Bredt-Savelsberg and Bund.²²

	<i>Borneol</i>		<i>Isoborneol</i>	
	<i>Active</i>	<i>Inactive</i>	<i>Active</i>	<i>Inactive</i>
<i>m</i> -dinitrobenzoate	154° <i>trans</i> ²¹ 155° <i>cis</i> ²¹	...	138° ²¹
<i>p</i> -nitrobenzoate	136° ²⁰	...	120° ²⁰	131°–132° ²⁰
3,5-dinitrobenzoate	156°–157° ²⁰	...	139° ²⁰	132°–133° ²⁰
α -naphthylamine addition product of 3,5-dinitro- benzoate	140.5° ²²	...	148° ²²	...

For purposes of identification and differentiation, the reaction of borneol and isoborneol with nitric acid (d 1.4 free from NO₂) may be used. The former yields camphor, the latter a liquid reaction mixture.

Differentiation of borneol and isoborneol may be simplified by the fact that bornyl derivatives are, in general, less soluble than the isobornyl derivatives.

In order to distinguish between borneol, isoborneol, and camphene hydrate, Aschan²³ suggested dissolving the alcohols in acetic acid, adding sulfuric acid (50%), and boiling the solution for a few seconds. On cooling, the borneol crystallizes unchanged, whereas the isoborneol solution becomes milky at 10° and clarifies at 18° to 20°. The camphene hydrate solution yields two layers because camphene hydrate is rapidly dehydrated to camphene.

When the worker is concerned only with *d*-, *l*- or *dl*-borneol, several specific reactions and derivatives are important—the *d*- tartrates should be very useful in this case, as they yield individual properties for each form; however, they are not quickly prepared. The fumarates and malonates are likewise solid derivatives that have been prepared for the *d*-, *l*- and *dl*-borneols by Abbot and co-workers^{24,25,26} who reported these melting points:

	<i>d</i>	<i>l</i>	<i>dl</i>
Monobornyl <i>d</i> - tartrate ²⁴	130.5°–131.5°	157.5°–158.5°	140°–145°
Monobornyl malonate ²⁵	65°–66°	65°–66°	71°–72°
Dibornyl fumarate ²⁶	106°–107°	106°	131°

With Beckmann's chromic acid mixture, borneol is oxidized to camphor which may be characterized by the preparation of its oxime m. 118°–119°.

On acetylation, *d*- or *l*-borneol yields *d*- or *l*-bornyl acetate m. 29°. The optically inactive esters are liquid.

With chloral or bromal, borneol forms addition products, according to Haller²⁷ and Minguin.²⁸ The chloral addition compound of *d*-, *l*-, or *dl*-borneol melts at 55°–56°;²⁷ the bromal compound of *d*- or *l*-borneol at 105°–109°,²⁸ and that of *dl*-borneol at 79°–82°.²⁸ Bertram and Walbaum²⁹ reported a melting point of 98°–99° for the bromal compound prepared from "ordinary" borneol, and 71°–72° for that of isoborneol.

About the quantitative determination of borneol, see Vol. I, Chapter 4, "The Examination and Analysis of Essential Oils, Synthetics, and Isolates," p. 276.

Properties.—Borneol crystallizes (petroleum ether) in the form of hexagonal leaflets or plates. Its odor is camphor-like, but sharper.

The following properties have been found characteristic of this alcohol in early as well as recent investigations by Pelouze,³⁰ Yamada,³¹ Clark and Read,³² Asahina, Ishidate and Sano,³³ Beckmann,³⁴ Haller,^{35,36,37} Pickard and Littlebury,³⁸ Keffler and Guthrie,³⁹ Ross and Somerville,⁴⁰ Bertram and Walbaum,⁴¹ and von Sobbe:⁴²

	<i>d</i> -Borneol		<i>l</i> -Borneol
m.	204°–205° ^{31,32,41,42}		204° ³⁴
	206.5° ⁴⁰		
	204° ³³ (<i>trans</i>)		
	278° ³³ (<i>cis</i>)		
b.	212° ^{30,41}		212°
			207.2° ⁴⁰
[α] _D	+37° 22' to +37° 55' ^{34,35,38}	[α] _D ²⁵	–38° 7' ³⁹
[α] _D ¹⁶	+37° 6' to +37° 19' ^{36,40}	[α] _D	–37° 46' ³⁵
[α] _D ¹¹	+38° 6' ³¹ (<i>cis</i>) (alc.)	[α] _D ^{13–15}	–37° 50' ³⁷ (c = 7.7 in toluene)
[α] _D ¹¹	+38° 26' ³¹ (<i>cis</i>) (benz.)	[α] _D ^{14.5}	–37° 30' ⁴⁰ (c = 8, in toluene)

The borneol contained in essential oils is usually more or less racemized. The melting point of the racemic form has been found by Haller⁴³ as 210.3°, whereas that for the *d*- and *l*- forms has been recorded by several workers in the range 206°–208°. However, this figure is not at the same time associated with optima in optical properties and there exists some reason to believe, according to McKenzie,⁴⁴ that *d*-borneol and *l*-isoborneol form solid solutions—a fact which may account for observed variations.

Borneol is very readily oxidized to camphor—for example, by distillation over copper oxide, or by the action of chlorine either in presence or absence of water.

Against dehydrating agents such as zinc chloride or dilute sulfuric acid, borneol is quite stable and thereby differs from isoborneol.

Although a saturated alcohol, borneol forms loose addition compounds with bromine and hydrogen halides which, however, are not suitable for its identification. With hydrogen halides, as well as with phosphorus halides, the corresponding borneol halides can be obtained, but it is better to prepare them from α -pinene. Thus, bornyl chloride may be prepared easily by treating α -pinene, dissolved in chloroform, with hydrogen chloride at 0°. With sodium, borneol yields the corresponding sodium derivative.

Use.—Borneol is used for the scenting of all kinds of technical preparations. Much more important, however, are its esters, particularly bornyl acetate, which, due to its typical pine needle odor, serves widely for the perfuming of soaps, bath preparations, inhalants, room sprays, etc. Some bornyl esters are employed in medicinal preparations.

¹ *Ber.* **53** (1920), 1821; **55** (1922), 2506.

² *Bull. soc. chim.* [4] **39** (1926), 925.

³ *Liebigs Ann.* **477** (1930), 157. *Nachr. Akad. Wiss. Göttingen Math. physik. Klasse* (1941), 59. *Chem. Zentr.* I (1942), 2007.

⁴ *Ibid.* **480** (1930), 298.

⁵ *Ber.* **68** (1935), 555.

⁶ *Liebigs Ann.* **522** (1936), 137.

⁷ *Ber.* **69** (1936), 343.

⁸ *J. Gen. Chem. U.S.S.R.* **7** (1937), 415.

⁹ *J. Am. Chem. Soc.* **59** (1937), 820.

¹⁰ *Bull. Chem. Soc. Japan* **16** (1941), 187. *Chem. Abstracts* **36** (1942), 759.

¹¹ *Compt. rend.* **108** (1889), 1308.

¹² *Gildemeister & Hoffmann*, "Die Ätherischen Öle," 3d Ed., Vol. I, 480.

¹³ *J. prakt. Chem.* II, **49** (1894), 8. See also Hesse, *Ber.* **39** (1906), 1144.

¹⁴ *J. Russ. Phys. Chem. Soc.* **36** (1904), 1035. See also Pickard and Littlebury, *J. Chem. Soc.* **91** (1907), 1973.

¹⁵ *J. Chem. Soc.* **91** (1907), 1973.

¹⁶ *J. Chem. Soc. Japan* **53** (1932), 807. *Chem. Abstracts* **27** (1933), 281.

¹⁷ *Bull. Inst. Phys. Chem. Research Tokyo* **7** (1928), 257. *Chem. Abstracts* **22** (1928), 3406.

¹⁸ *Vavon and Peignier*, *Bull. soc. chim.* [4], **39** (1926), 937.

¹⁹ *J. Chem. Soc.* (1926), 2770.

²⁰ *Liebigs Ann.* **549** (1941), 186 (*Brit. Chem. Phys. Abstracts* (1942), A II, 201); **550** (1942), 269.

²¹ *Ber.* **69** (1936), 343.

- ²² *J. prakt. Chem.* **131** (1931), 45.
²³ *Liebigs Ann.* **410** (1915), 238.
²⁴ *Ber.* **71B** (1938), 16.
²⁵ *Ber.* **71B** (1938), 9.
²⁶ *J. Chem. Soc.* **91** (1907), 1225. *Ber.* **70** (1937), 163.
²⁷ *Compt. rend.* **112** (1891), 145.
²⁸ *Ibid.* **116** (1893), 889.
²⁹ *J. prakt. Chem.* [2], **49** (1894), 5.
³⁰ *Compt. rend.* **11** (1840), 366.
³¹ *Bull. Chem. Soc. Japan* **16** (1941), 187. *Chem. Abstracts* **36** (1942), 759.
³² *J. Chem. Soc.* (1934), 1773.
³³ *Ber.* **69B** (1936), 343.
³⁴ *Liebigs Ann.* **250** (1889), 353. *J. prakt. Chem.* [2], **55** (1897), 33.
³⁵ *Compt. rend.* **109** (1889), 30.
³⁶ *Ann. chim. phys.* [6], **27** (1892), 395.
³⁷ *Compt. rend.* **112** (1891), 143. *Ann. chim. phys.* [6], **27** (1892), 425.
³⁸ *J. Chem. Soc.* **91** (1907), 1973.
³⁹ *J. Phys. Chem.* **31** (1927), 58.
⁴⁰ *J. Chem. Soc.* (1926), 2773.
⁴¹ *J. prakt. Chem.* [2], **49** (1894), 3, 15.
⁴² *Ibid.* [2], **77** (1908), 511.
⁴³ *Compt. rend.* **105** (1887), 66.
⁴⁴ *J. Chem. Soc.* **91** (1907), 1225.

SUGGESTED ADDITIONAL LITERATURE

C. Neuberg, K. P. Jacobson and J. Wagner, "Formation and Cleavage of Glucosides as a Method for the Chemical and Biochemical Separation of Racemic Alcohols into Their Optically Active Forms," *Fermentforschung* **10** (1929), 491. *Chem. Abstracts* **23** (1929), 4207.

P. P. Shoruigin and Ya. Makarov-Zemlyanskii, "Tribornyl Borate and Its Use in Separation of Borneol from Camphor," *J. Russ. Phys.-Chem. Soc.* **62** (1930), 2047. *Chem. Abstracts* **25** (1931), 4251.

T. S. Patterson, Janet H. Blackwood and J. McWhinnie Stewart, "Depression of the Melting Point of *r*-Isoborneol, *l*-Borneol and *d*-Camphor Oxime by Various Substances," *J. Chem. Soc.* (1933), 93. *Chem. Abstracts* **27** (1933), 1625.

K. Alder and G. Stein, "Über den sterischen Verlauf von Additions und Substitutionsreaktionen. Zur Stereochemie der Dien-Synthese. Über endo-exo-Isomerie," *Liebigs Ann.* **514** (1934), 197, 211.

Baji Vinajak Thosar and Bawa Kartar Singh, "Raman Spectra of *d*-, *l*- and *dl*-Forms of Borneol and Camphor," *Proc. Indian Acad. Sci.* **6A** (1937), 105. *Chem. Abstracts* **32** (1938), 48.

B. P. Osanov and A. I. Zarakovskaya, "Methods for analyzing camphor," *Lesokhimicheskaya Prom.* 1939, No. 12, 27. *Khim. Referat. Zhur.* No. 5, (1940), 79. *Chem. Abstracts* **36** (1942), 3749.

Seiichi Yamada, "Camphor, borneol, and allied substances," *Bull. Chem. Soc. Japan* **16** (1941), 336. *Chem. Abstracts* **41** (1947), 4474.

Y. R. Naves, "Volatile Plant Substances. Application of Selective Formylation of Borneol, 3-Octanol and Benzyl Alcohol in the Presence of Linalool and Its Esters in the Analysis of Essential Oils," *Helv. Chim. Acta* **27** (1944), 942 (in French). *Chem. Abstracts* **39** (1945), 1017.

Isoborneol

C₁₀H₁₈O

Mol. Weight 154.24

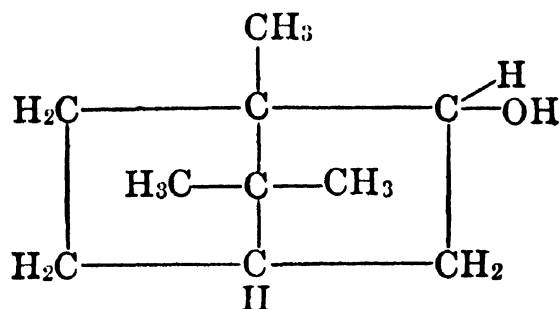

Occurrence.—Isoborneol (see “Borneol”) does not occur in nature. However, as it appears in so many reactions associated with its naturally occurring and important isomer, viz., borneol, consideration must, therefore, be given to this hydroxy terpene.

Isolation and Identification.—Regarding the isolation and identification of isoborneol, see “Borneol.”

Besides those compounds cited in connection with borneol that are primarily of use to differentiate between the stereoisomers borneol vs. isoborneol, two additional derivatives may be mentioned that are of limited use only and are to be recommended when borneol is not present in substantial quantities.

Isobornyl Acid Phthalates(Pickard and Littlebury ¹)

<i>Isomer</i>	<i>m.</i>	$[\alpha]_D$
<i>dl</i>	168°	±0°
<i>d</i>	167°	+76° 53'
<i>l</i>	167°	-76° 56'

Isobornyl-l-menthylcarbamate

<i>Isomer</i>	<i>m.</i>	$[\alpha]_D$
<i>dl</i>	120°	-55° 48'
<i>d</i>	128°	-1° 25'
<i>l</i>	118°	-112° 0'

Properties.—The properties shown in the tabulation below have been reported by Pickard and Littlebury,² Kenyon and Pickard,³ Vavon and Peignier,⁴ Haller,⁵ Bertram and Walbaum,⁶ Kondakov,⁷ Henderson and Heilbron,⁸ Peignier,⁹ and Yamada:¹⁰

	<i>d</i>	<i>l</i>	<i>dl</i>
<i>m.</i>	...	212°–213° ^{5,10} (sealed tube)	212° ^{6,7} (sealed tube)
	(214°) ²	(214°) ²	
	(217°) ⁸	(217°) ⁸	
		(218°) (corr.) ⁹	
$[\alpha]_D$	+34° 15' ²	-34° 25' ¹⁰	
	(alc.)		
	+33° 53' ³	-34° 20' ²	
$[\alpha]_{578}$		-34° 0' ⁴ (c = 0.05 in abs. alc.)	

Particular attention should be given to selection of the solvent when measurement of $[\alpha]_D$ is being made, as Peignier¹¹ has cited the fact that values ranging from $-39^\circ 42'$ to $-20^\circ 18'$ have been obtained for laevo-isoborneol in various organic solvents, whereas Haller¹² found $-33^\circ 32'$ to $-18^\circ 57'$. Kenyon and Pickard¹³ obtained similar results for dextro-isoborneol, recording $+33^\circ 53'$ to $+20^\circ 20'$; Pickard and Littlebury¹⁴ reported $+34^\circ 2'$ to $+21^\circ 19'$.

Some variation has also been observed in the melting point of the active isomers of isoborneol which has been reported ranging from 212° – 218° . However, these variations may be due in part to the rate of heating as this product readily sublimes and it is necessary to determine the melting point in a sealed tube to obtain uniform results.

The treatment of camphene with a mixture of sulfuric acid (50 per cent) and glacial acetic acid, according to the method of Bertram and Walbaum,¹⁵ yields isobornyl acetate which on hydrolysis gives an almost completely racemized *dl*-isoborneol. Most general methods employed for the preparation of borneol yield also some isoborneol. Borneol and isoborneol resemble one another in regard to their general reactions, but isoborneol is more easily dehydrated to camphene. On oxidation by the action of air, or by oxygen in the presence of catalysts, or by ozone, nitrogen oxides, nitric acid or potassium permanganate, *d*-isoborneol¹⁶ gives *l*-camphor, whereas *l*-isoborneol yields *d*-camphor. When distilled over copper oxide, isoborneol is not oxidized to camphor and thereby differs from borneol.

Use.—The esters of isoborneol, especially the acetate, have attained great technical importance, being used in cosmetic and bath preparations, in room sprays, and for the scenting of soaps. They possess a characteristic odor of pine needles.

¹ *J. Chem. Soc.* **91** (1907), 1978.

² *Ibid.*, 1975, 1980.

³ *Ibid.* **107** (1915), 59.

⁴ *Compt. rend.* **181** (1925), 184. *Bull. soc. chim.* [4], **39** (1926), 927.

⁵ *Compt. rend.* **109** (1889), 188. *Ann. chim. phys.* [6], **27** (1892), 425.

⁶ *J. prakt. Chem.* [2], **49** (1894), 2.

⁷ *Ibid.* [2], **65** (1902), 227.

⁸ *Proc. Chem. Soc.* **29** (1913), 381.

⁹ Thesis Nancy (1926). *Parfums France* **4** (1926), 196.

¹⁰ *Bull. Chem. Soc. Japan* **16** (1941), 187. *Chem. Abstracts* **36** (1942), 759.

¹¹ Thesis Nancy (1926). *Parfums France* **4** (1926), 196.

¹² *Compt. rend.* **112** (1891), 143. *Ann. chim. phys.* [6], **27** (1892), 425.

¹³ *J. Chem. Soc.* **107** (1915), 59.

¹⁴ *Ibid.* **91** (1907), 1978.

¹⁵ *J. prakt. Chem.* II, **49** (1914), 1.

¹⁶ In certain literature, dextrorotatory isoborneol is defined as *l*-isoborneol, and laevo-isoborneol as *d*-isoborneol. This results from the fact that the derived camphors of active isoborneols are opposite in sign. Publications are inconsistent in their nomenclature on this point. Heilbron and Beilstein maintain the anomaly, whereas the International Critical Tables do not.

SUGGESTED ADDITIONAL LITERATURE

E. Puxeddu, "The Constitution of Isoborneol," *Gazz. chim. ital.* **59** (1929), 59. *Chem. Abstracts* **23** (1929), 3668.

Ossian Aschan, "Studies in the Reactions Involved in the Formation of Synthetic Camphor," *Finska Kemistsamfundets Medd.* **38** (1929), 94. *Chem. Abstracts* **24** (1930), 1636.

Tsutomu Kuwata and Shizuka Tategai, "Catalytic Action of Silica Gel in the Reaction of Camphene and Oxalic Acid. A Synthesis of Isoborneol," *J. Soc. Chem. Ind. Japan* **35**, Suppl. binding 303, (1932). *Chem. Abstracts* **26** (1932), 5552.

Karl Stephen, "Esters of Isoborneol," German Patent No. 580,514, July 13, 1933. *Chem. Abstracts* **28** (1934), 1048.

Camphene Hydrate

 $C_{10}H_{18}O$

Mol. Weight 154.24

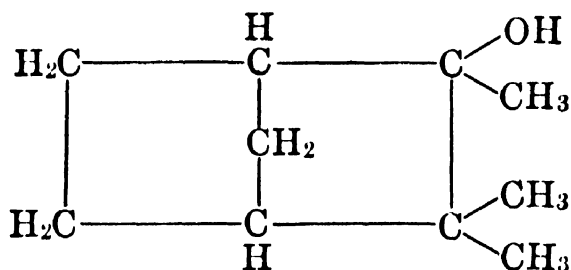

Occurrence.—Camphene hydrate does not occur in nature but is an intermediate product in the hydration of camphene to isoborneol and borneol, a fact proved by Aschan.¹

Isolation.—This hydrated terpene has been conveniently isolated by treating camphene hydrochloride with milk of lime. By this same operation, bornyl chloride and isobornyl chloride, too, yield camphene hydrate.

Identification.—Camphene hydrate forms several characteristic derivatives; the most useful are apparently the benzoates. Meerwein et al.² report the *m*-nitrobenzoate as melting at 86°–86.5°. Hückel et al.³ characterized the *p*-nitro compound as m. 96°, $[\alpha]_D -24^\circ 54'$ in ethyl alcohol; the *p*-benzamidobenzoate, m. 129°, $[\alpha]_D^{20} -12^\circ 48'$ in benzene; the 3,5-dinitrobenzoate as m. 112°, $[\alpha]_D^{17} -24^\circ 54'$ in absolute alcohol. Aschan⁴ prepared the phenylurethane m. 89°. Moreover, camphene hydrate can be readily dehydrated; camphene is thus regenerated. This hydrocarbon lends itself to rather easy characterization. Dehydration may be effected by shaking camphene hydrate with warm dilute mineral acids, by boiling in glacial acetic acid, in some cases even by mere distillation.

Properties.—Camphene hydrate is a hard, crystalline mass which, according to Aschan⁵ and German patent No. 219,243,⁶ after sublimation melts at 149°–151°, b. 204°–207.5°, $[\alpha]_D -21^\circ 48'$.⁵ Its odor is menthol-like with a musty note. An isolate has been reported by Meerwein and van Emster.⁷

Use.—Camphene hydrate, as such, is not used in our industries.

¹ *Medd. Vetenskapsakad. Nobelinstit.* **5**, No. 8 (1919), 19.

² *Liebigs Ann.* **453** (1927), 16.

³ *Ibid.*, **549** (1941), 186.

⁴ *Ibid.*, **410** (1915), 222.

⁵ *Liebigs Ann.* **383** (1911), 18, 37.

⁶ *Chem. Zentr.* I (1910), 1074. *Friedländers Fortschritte der Teerfarbenfabrikation* (Berlin) **9**, 1140.

⁷ *Ber.* **53** (1920), 1822.

SUGGESTED ADDITIONAL LITERATURE

J. Brecht, "Cis- and cis-trans-Camphenehydrate-meso-carboxylic Acid and the Racemic *o*- and *p*-Isoborneolcarboxylic Acids," *J. prakt. Chem.* **131** (1931), 137. *Chem. Abstracts* **25** (1931), 5156.

Thujyl Alcohol

(Tanacetyl Alcohol)

C₁₀H₁₈O

Mol. Weight 154.24

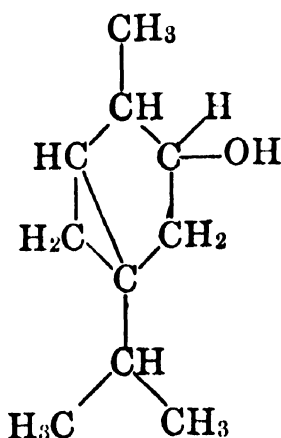

Thujyl alcohol can exist theoretically in eight optically active and four externally compensated modifications. The naturally occurring alcohol consists of a mixture of stereoisomers which differ in their physical properties. Some of them have been isolated by Paolini and collaborators,¹ and by Tschugaev and Fomin.² However, Short and Read,³ realizing the lability and existence of dynamic equilibria in the thujone series, from which these alcohols are primarily derived, devised new methods for the preparation of the first optically homogeneous thujyl alcohols and applied a scheme of nomenclature to these isomers, patterned along lines of the menthol-isomenthol series.⁴

Occurrence.—This bicyclic secondary alcohol occurs in the free state (about 10 per cent) and as ester (about 14 per cent) in oil of wormwood (*Artemisia absinthium* L.), furthermore in oil of *Thuja plicata* and *Artemisia camphorata* (about 40 per cent as free alcohol, and about 12 per cent in ester form).

Huzita⁵ reported the presence of thujyl alcohol in the orthodon oils, and Covello⁶ found 21.77 per cent free and 5.95 per cent combined alcohol in *Artemisia verlotorum* Lamotte.

Isolation.—According to Schimmel & Co.,⁷ thujyl alcohol can be isolated, from wormwood oil, by first freeing the oil from thujone by treatment with bisulfite solution, then saponifying, and repeatedly fractionating the remaining oil.

Paolini,⁸ and Tschugaev and Fomin⁹ found the acid phthalates to be very effective agents for the purification of the isomeric thujyl alcohols; they also recommended the strychnine and chinchonine salts of this acid ester.

For the preparation of optically homogeneous samples Read and Short¹⁰ fractionally crystallized either the *p*-nitrobenzoates or the 3,5-dinitrobenzoates of the alcohols.

Identification.—Short and Read¹¹ found that optically homogeneous samples of *l*-thujyl alcohol and *d*-isothujyl alcohol, obtained either from the hydrogenated α -thujone in thuja oil or from β -thujone in tansy oil, yielded the following characteristic derivatives:

Derivative	<i>Isomers of Thujyl Alcohol</i>			
		<i>l</i>		<i>d</i> -iso
<i>p</i> -Nitrobenzoate	m.	101°	m.	78°
	$[\alpha]_D^{15}$	−32° 15'	$[\alpha]_D^{13}$	+107° 0'
	(<i>c</i> = 2 in CHCl ₃)		(<i>c</i> = 1 in CHCl ₃)	
3,5-Dinitrobenzoate	m.	106°	m.	92°
	$[\alpha]_D^{19}$	−24° 30'	$[\alpha]_D^{17}$	+96° 45'
	(<i>c</i> = 2 in CHCl ₃)		(<i>c</i> = 2 in CHCl ₃)	

Oxidation of *l*-thujyl alcohol yields *l*-thujone (α -thujone) b_9 74.5°, α_D^{18} −19° 56'; while a similar reaction with *d*-isothujyl alcohol gives *d*-isothujone (β -thujone) b_{10} 76°, α_D^{15} +72° 27'. These ketones yield 2,4-dinitrophenylhydrazones melting respectively at 186°–188° and 116°. The acid phthalate of a relatively pure *d*-isothujyl alcohol melts at 120°, according to Paolini.¹²

Properties.—The fractions of essential oils described as thujyl alcohol are syrupy oils with an odor similar to that of carvomenthol. As pointed out, natural thujyl alcohol is regarded as a mixture of stereoisomeric forms, the fractions (from thuja and French wormwood oil) possessing this range of properties, according to Paolini and Divizia,¹³ and Rose and Livingston:¹⁴

b.	208°–210° ¹²	$[\alpha]_D$	+22° 20' ¹²
b_{757}	210°–220° ¹³	$[\alpha]_D^{25}$	+29° 48' ¹³
d	0.938 ¹²	n_D^{25}	1.46207 ¹³
d_{25}	0.9266 ¹³	n_D^{16}	1.4791 ¹²

Due to the presence of the cyclopropane ring, the molecular refraction of thujyl alcohol shows marked exaltation (+0.62).

The stereochemically homogeneous samples of Short and Read¹⁵ are reported as follows:

d-Isothujyl alcohol, a sweet smelling, syrupy liquid obtained by hydrogenating α - or β -thujones with sodium and alcohol, and purified through the 3,5-dinitrobenzoate, had these properties:

b_{16}	103°
α_D^{14}	+106° 42'
$n_D^{16.5}$	1.4627

The same alcohol was obtained in the course of investigations by Paolini,¹⁶ and Tschugaev and Fomin:¹⁷

b.	206° ¹⁵ (regenerated from the acid phthalate)	$[\alpha]_D$	+114° 40' ¹⁶
		$[\alpha]_D^{20}$	+116° 56' ¹⁶
d_4^{20}	0.9187 ¹⁶	n_D^{16}	1.4625 ¹⁵

l-Thujyl alcohol, derived from catalytic hydrogenation of α -thujone and purified by the *p*-nitrobenzoate, is reported as:

m.	66°–67°
$[\alpha]_D^{16}$	–20° 30' (c = 1 in methyl alcohol)
$[\alpha]_D^{15}$	–22° 30' (c = 1 in ethyl alcohol)

Thujyl alcohol is a quite stable substance. Unlike thujone, it does not undergo isomerization on heating. Due to the tendency for hydrocarbon formation, esterification of thujyl alcohol does not take place smoothly. Nevertheless, a few esters have been described.

Use.—Thujyl alcohol, as such, is not used in our industries.

¹ *Atti accad. Lincei* [5], **20** (1911), I, 765, 769; [5], **21** (1912), I, 570. *Gazz. chim. ital.* **42** I (1912), 41.

² *Ber.* **45** (1912), 1293.

³ *J. Chem. Soc.* (1938), 2016.

⁴ Synonyms in nomenclature of thujyl alcohols:

<i>l</i> -thujyl-alcohol	<i>l</i> -tanacetyl-alcohol	α -thujyl-alcohol
<i>d</i> -isothujyl-alcohol	<i>d</i> -tanacetyl-alcohol	β -thujyl-alcohol
		γ -thujyl-alcohol
		δ -thujyl-alcohol

⁵ *J. Chem. Soc. Japan* **61** (1940), 137. *Chem. Abstracts* **36** (1942), 6752.

⁶ *Bull. orto. botan. univ. Napoli* [2], **15** (1941), 61–71. *Chem. Abstracts* **37** (1943), 4855.

⁷ *Ber. Schimmel & Co.*, April (1897), 51.

⁸ *Atti accad. Lincei* [5], **20** (1911), I, 765, 769; [5], **21** (1912), I, 570. *Gazz. chim. ital.* **42**, I (1912), 41.

⁹ *Ber.* **45** (1912), 1293.

¹⁰ *J. Chem. Soc.* (1938), 2016.

¹¹ *Ibid.*, 2019.

¹² *Atti accad. Lincei* [5], **20** (1911), I, 769.

¹³ *Ibid.* [5], **21** (1912), I, 571.

¹⁴ *J. Am. Chem. Soc.* **34** (1912), 202.

¹⁵ *J. Chem. Soc.* (1938), 2019.

¹⁶ *Atti accad. Lincei* [5], **20** (1911), I, 765.

¹⁷ *Ber.* **45** (1912), 1293.

Fenchyl Alcohol

(Fenchol)

 $C_{10}H_{18}O$

Mol. Weight 154.24

2-Fenchanol

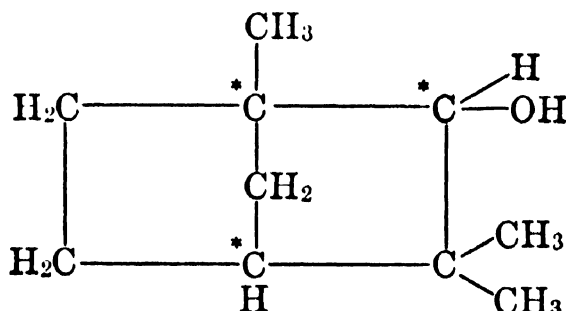

The fenchols are readily formed by hydrogenation of fenchone. However, because of the configuration of the fenchone molecule, reduction of the optically active fenchones may theoretically result in two types of fenchols, differing in regard to the spatial arrangement of the hydroxyl group. Thus, two series of alcohols, now described ^{1,2} as α - and β -fenchols, should arise. In such a bicyclic molecule these geometric isomers are related as an "exo" and "endo" type of structure, the question of spatial arrangement of the hydroxyl group being still a problem awaiting final decision.

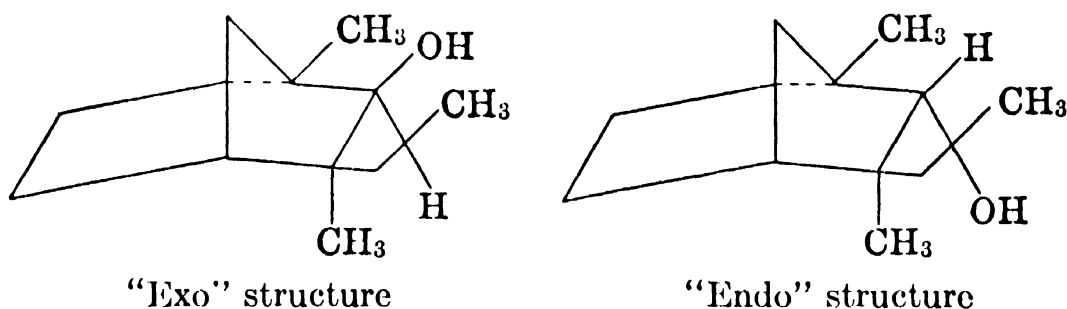

The presence of the asymmetric carbons allows for a *d*-, *l*- and *dl*- form in both the α - and β - series.

It was primarily the work of Kenyon and Priston,³ and Schmidt and Schulz⁴ that accomplished the complete separation of these stereoisomers.

Kenyon and Priston⁵ reduced optically active fenchone with sodium and alcohol—a method originally employed by Wallach⁶—and obtained a mixture of stereoisomeric fenchols. This procedure, however, yields fenchols primarily of the α -series. Taking advantage of the lesser solubility of the α -phthalates and of the β -*p*-nitrobenzoates, these authors succeeded in separating the *l*- α - and β -fenchols. Schimmel & Co. reduced the fenchones catalytically, using a nickel catalyst, and obtained principally the labile β -isomers. Later, Hückel, Kindler and Wolowski⁷ refined this method and confirmed much of the earlier data on the optically active fenchols.

Occurrence.—According to Schimmel & Co.,⁸ Komppa and Beckmann,⁹ Zeitschel and Todenhöfer,¹⁰ and Humphrey,¹¹ *dl*- α -fenchyl alcohol occurs in the oil distilled from old roots of *Pinus palustris* (yellow pine oil).

A fenchyl alcohol has also been reported by Spoelstra¹² in the essential oil distilled from *Baeckea frutescens* L. and *Dalbergia parviflora* Roxb., and by Lobo¹³ in Spanish fennel oil.

Isolation.—The fraction b. 197°–204° of yellow pine oil is treated with phthalic anhydride and the acid phthalate saponified with an alcoholic solution of potassium hydroxide.

Nametkin,¹⁴ and Schimmel & Co.¹⁵ suggested a preliminary treatment of fenchol-containing fractions with phthalic acid in order to remove any contaminating tertiary alcohols. Patented processes¹⁶ recommend iodine, Fuller's earth, or activated carbon for the same purpose. After the treatment of the fenchol-containing fraction with phthalic anhydride, the acid phthalate is purified in alcohol, and the pure fenchol may be obtained by hydrolysis of the acid ester.

Hunger¹⁷ purified the alcohol by esterification of fenchol fractions with the calculated amount of boric acid, by recrystallization, and hydrolysis.

Identification.—Fenchyl alcohol can be characterized by the preparation of several derivatives, but the most complete data on isomers of known type is that gathered on the fenchyl phenylurethanes and acid phthalates by Schimmel & Co.¹⁸

The derivatives shown in the table below have been reported by Schmidt and Schulz,¹⁹ Kenyon and Priston,²⁰ Komppa and Beckmann,²¹ Zeitschel and Todenhöfer,²² Nametkin,²³ Imoto,²⁴ Quist,²⁵ and Hückel, Kindler and Wolowski:²⁶ (See p. 253.)

Properties.—*dl*-Fenchyl alcohol, a solid at room temperature, possesses a peculiar, musty odor. The product as isolated relatively pure from yellow pine oil by Zeitschel and Todenhöfer²⁷ had these properties:

m.	38°–39°
b ₇₇₀	201.4°
$[\alpha]_D$	–0° 12'

These, in a large measure, confirm those recorded earlier by Gildemeister and Hoffmann.²⁸

Studying the stereoisomery of fenchyl alcohol, Schmidt and Schulz²⁹ reported properties for the various isomers of fenchol. (See p. 254.) These figures confirm earlier findings of Nametkin³⁰ on a sample of very pure *l*- α -fenchol and those of Kenyon and Priston³¹ on the *l*- α - and β - alcohols, and agree well with later observations by Hückel, Kindler and Wolowski³² on very pure *l*- β -fenchol. Schmidt and Schulz noted a marked difference in the odor of the stereoisomers. The α -fenchols possess a marked camphoraceous odor, whereas the β - isomers display a musty and mouldy smell.

On oxidation with chromic or nitric acid, fenchyl alcohol yields fenchone.

Use.—Fenchyl alcohol is used as an odor adjunct primarily in low priced technical preparations, soaps, bath salts, and room sprays of pine character.

DERIVATIVES: m. °C.

	Oxalate	<i>p</i> -Nitrobenzoate *	Phenylurethane	Acid Phthalate	<i>p</i> -Cl-Benzoate	α -Naphthylurethane	Borate	Formate	3,5-Dinitrobenzoate	Acid Succinate
<i>dl</i> - α -Fenchol	100.5–101.5 ²⁵	94–95 ²¹	104 ^{19,22}	169 ^{19,22}	...	148.5–149.5 ²¹	119–122 ²²	21 ²²
<i>d</i> - α -Fenchol	92.0–93.5 ²⁵	...	81 ¹⁹	145.5 ¹⁹
<i>l</i> - α -Fenchol	92.0–93.5 ²⁵	108–109 ²⁰	81–82 ¹⁹	146 ^{19,20}	73–74 ²⁰	141 ²⁶	...
<i>dl</i> - β -Fenchol	90.5 ¹⁹	146.5 ²³
<i>d</i> - β -Fenchol	89 ¹⁹	153.5 ¹⁹
<i>l</i> - β -Fenchol	90 ²⁶	81 ²⁶	89–90 ¹⁹	151 ¹⁹
		82–83 ²⁰		152 ¹⁹	157 ²⁶	44 ²⁶
				153 ²⁰		
				154 ²⁶		

* Imoto²⁴ reported an α -fenchyl *p*-nitrobenzoate m. 107°–108°, and a probable β -fenchyl *p*-nitrobenzoate m. 83.5°–85°.

	Obtained from	m.	b.	d	n _D	[α] _D ^b	Phenyl-urethane m.	Acid Phthalate m.	[α] _D of Acid Phthalate ^b
<i>dl</i> -α-Fenchol	<i>dl</i> -Fenchone	38°	b. 199.5°	0.9420 ^a	1.47013 ^a	±0°	104°	169°	±0°
<i>dl</i> -β-Fenchol	<i>dl</i> -Fenchone	6.3°	b. 200.5°	0.9428 ^a	1.47033 ^a	±0°	90.5°	153.5°	±0°
<i>l</i> -α-Fenchol	<i>d</i> -Fenchone	48°	b. 199.5°	-11°	81°-82°	146°	+21° 40'
<i>d</i> -α-Fenchol	<i>l</i> -Fenchone	47°	+11° 50'	81°	145.5°	-20° 50'
<i>l</i> -β-Fenchol	<i>d</i> -Fenchone	5.6°	b. 200.5°	0.964 ^c	1.47879 ^c	-21° 40'	89-90°	152°	+10° 20'
<i>d</i> -β-Fenchol	<i>l</i> -Fenchone	+21° 50'	89°	151°	-10° 40'

Observed by Nametkin

<i>l</i> -α-Fenchol	<i>d</i> -Fenchone	49°	b ₇₅₀ 200.5°	-10° 54'	...	146.5°	+23° 14'
---------------------	--------------------	-----	-------------------------	-----	-----	----------	-----	--------	----------

Observed by Kenyon and Priston

<i>l</i> -α-Fenchol	<i>d</i> -Fenchone	47°	b ₂₀ 94°	0.9641 ^d	...	+12° 53'	...	146°	+21° 36'
<i>l</i> -β-Fenchol	<i>d</i> -Fenchone	3°-4°	b ₁₈ 91°	0.9605 ^d	...	+23° 17'	...	153°	+10° 18'

Observed by Hüchel et al.

<i>l</i> -β-Fenchol	<i>d</i> -Fenchone	5.6°	b ₇₅₂ 200°	0.9629 ^e	1.47780 ^d	-23° 23' ^f	...	154°	+10° 11' ^h
						-23° 5' ^g			

^a Taken at 40°.

^b The rotations were taken with 5% solutions in alcohol.

^c Taken at 15°.

^d Taken at 20°.

^e Taken at 20.5°.

^f No solvent.

^g 4.332% in alcohol.

^h 248.1 mg./5 cc. alcohol.

- ¹ Komppa and Roschier, *Ann. Acad. Sci. Fennicae* [A], **7** (1915), 1. *Chem. Abstracts* **11** (1917), 3041.
² *Ber. Schimmel & Co.* (1935), 97.
³ *J. Chem. Soc.* **127** (1925), 1472.
⁴ *Ber. Schimmel & Co.* (1935), 97.
⁵ *J. Chem. Soc.* **127** (1925), 1472.
⁶ *Liebigs Ann.* **263** (1891), 143; **272** (1893), 104.
⁷ *Ber.* **77B** (1944), 220. *Chem. Abstracts* **39** (1945), 3273.
⁸ *Ber. Schimmel & Co.*, April (1910), 107.
⁹ *Ber.* **68** (1935), 10.
¹⁰ *J. prakt. Chem.* **133** (1932), 374.
¹¹ *Trans. Inst. Chem. Eng.* **9** (1931), 40.
¹² *Rec. trav. chim.* **50** (1931), 433.
¹³ *Ion* **3** (1943), 410.
¹⁴ *J. prakt. Chem. N.F.* **106** (1923), 28.
¹⁵ *Ber. Schimmel & Co.* (1935), 93.
¹⁶ See U. S. Patent No. 1,887,171, Nov. 8, 1933, L. T. Smith to Hercules Powder Co.; U. S. Patent No. 1,932,183, Oct. 24, 1934, I. W. Humphrey to Hercules Powder Co.
¹⁷ *Seifensieder Ztg.* **67** (1940), 377.
¹⁸ *Ber. Schimmel & Co.* (1935), 97.
¹⁹ *Ibid.*
²⁰ *J. Chem. Soc.* **127** (1925), 1472.
²¹ *Ber.* **68B** (1935), 10.
²² *J. prakt. Chem.* **133** (1932), 374.
²³ *Ibid.* **106** (1923), 25.
²⁴ *J. Soc. Chem. Ind. Japan* **41**, Suppl. binding 211, 1938. *Chem. Abstracts* **32** (1938), 7438.
²⁵ *Liebigs Ann.* **417** (1918), 295.
²⁶ *Ber.* **77B** (1944), 220.
²⁷ *J. prakt. Chem.* **133** (1932), 374.
²⁸ "Die Ätherischen Öle," 3d Ed., Vol. I, 484. See also Wallach, *Liebigs Ann.* **272** (1893), 107.
²⁹ *Ber. Schimmel & Co.* (1935), 97.
³⁰ *J. prakt. Chem. N.F.* **106** (1923), 25.
³¹ *J. Chem. Soc.* **127** (1925), 1472.
³² *Ber.* **77B** (1944), 220.

SUGGESTED ADDITIONAL LITERATURE

Walter Hückel and Heinz Wolowski, "Transformation of α -Fenchylamine with Nitrous Acid," *Ber.* **80** (1947), 39. *Chem. Abstracts* **41** (1947), 3077.

Isofenchyl Alcohol

(Isofenhol)

 $C_{10}H_{18}O$

Mol. Weight 154.24

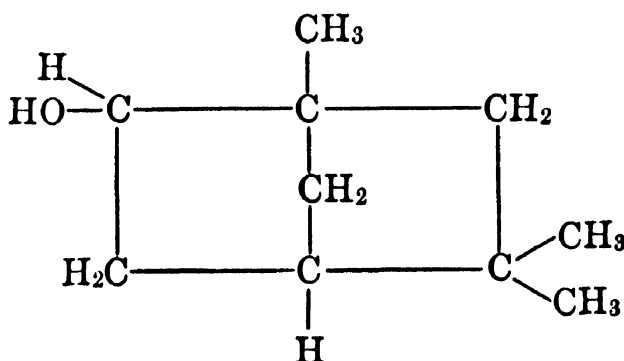

Occurrence.—This alcohol has not been found in nature.

Isolation.—Bertram and Helle¹ prepared the *l*-form by hydrating *l*- α -fenchene with sulfuric-acetic acid mixture. Wallach² obtained the *d*-form by hydrating *d*- α -fenchene and *l*- β -fenchene.

Identification.—Alder, Stein and Richert,³ and Schmidt and Todenhöfer⁴ accurately characterized this terpene alcohol by several isomeric derivatives, a number of which are summarized in the following table recording melting points:

	<i>l</i>	<i>d</i>	<i>dl</i>
Phenylurethane	106°–107° ⁴	liquid (β) ⁴	94°–95° ⁴ 101° (β) ³
Acid Phthalate	149°–150° ⁴ 155°–156° (α) ⁴	80° (β) ⁴	104°–105° (β) ³
Benzoate	70° (α) ⁴	liquid (β) ⁴	67° ⁴
α -Naphthylurethane	114° (α) ⁴	126° (β) ⁴	

Properties.—The racemic isomer has been prepared by Aschan⁵ from cyclofenchene, and the *l*- α - and β -forms have been studied by Schmidt and Todenhöfer.⁶ Investigating the stereoisomerism of optically active isofenchyl alcohol, Schmidt and Todenhöfer confirmed in a large measure certain earlier findings of Bertram and Helle,⁷ Wallach and Vivck,⁸ Qvist⁹ and Nametkin et al.¹⁰ Alder, Stein and Rickert¹¹ characterized the *dl*-products obtained from catalytic reduction of isofenchone. The constants recorded by some of these workers are tabularly summarized herewith:

<i>Property</i>	<i>l</i>	<i>d</i>	<i>dl</i>
m.	61°–62° (α) ⁶	8° (β) ⁶	42°–43° ⁵
b.			202°–203° ⁵
b ₇₅₅	200°–201° (α) ⁶	196°–197° (β) ⁶	
b ₁₅			89° (β) ¹¹
d ₄ ²⁰			0.9533 ⁵
d ₁₅ ¹⁵		0.952 (β) ⁶	
α_D	–25° 0' (α) ⁶	+14° 25' (β) ⁶	
$[\alpha]_D$	–26° 10' (α) ⁶ (10% alc.)	+15° 20' (β) ⁶ (10% alc.)	
n _D ²⁰			1.47556 ⁵
n _D ¹⁵	1.48005 (α) ⁶	1.47259 (β) ⁶	

Use.—Isofenchyl alcohol, as such, is not used in our industries.

¹ *J. prakt. Chem.* II, **61** (1900), 300.

² *Liebigs Ann.* **357** (1907), 56; **363** (1908), 5.

³ *Liebigs Ann.* **525** (1936), 221.

⁴ *Ber. Schimmel & Co.* (1937), 113. Cf. Aschan, *Liebigs Ann.* **387** (1912), 48.

⁵ *Liebigs Ann.* **387** (1912), 43.

⁶ *Ber. Schimmel & Co.* (1937), 113.

⁷ *J. prakt. Chem.* [2], **61** (1900), 300.

⁸ *Liebigs Ann.* **362** (1908), 192.

⁹ *Ibid.* **417** (1918), 313.

¹⁰ *J. Russ. Phys. Chem. Soc.* **49** (1917), 423; **51** (1919), 153. *J. prakt. Chem.* [2], **106** (1923), 31. *Chem. Zentr.* III (1923), 756.

¹¹ *Liebigs Ann.* **525** (1936), 221.

(c) TRICYCLIC TERPENE ALCOHOLS.

Teresantalol

$C_{10}H_{16}O$

Mol. Weight 152.23

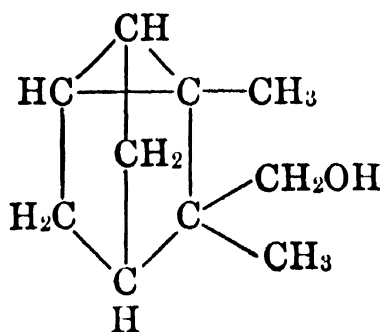

Occurrence.—According to Schimmel & Co.,¹ teresantalol occurs in East Indian sandalwood oil.

Identification.—The literature does not suggest that this alcohol has yielded itself any too readily to useful derivatives. Semmler and Bartelt² reported the acetate as:

b_{9-10}	$102^{\circ}-103^{\circ}$	α_D	$+21^{\circ} 0'$
d_{20}	1.019	n_D	1.470

Properties.—Both the *d*- and *dl*- isomer of this alcohol have been characterized. The racemic form has been studied by Asahina and Ishidate,³ and the active form by Semmler and Bartelt,⁴ and by the Schimmel chemists:⁵

Property	<i>d</i>	<i>dl</i>
m.	113° ⁴	118° ³
b.	$210^{\circ}-220^{\circ}$ ⁵	
b_{10}		$97^{\circ}-98^{\circ}$ ³
b_9	$95^{\circ}-98^{\circ}$ ⁴	
$[\alpha]_D$	$+11^{\circ} 58'$ ⁴ (in abs. alc.)	

Use.—Teresantalol is not used in our industries.

¹ *Ber. Schimmel & Co.*, Oct. (1910), 106; April (1911), 105.

² *Ber.* **40** (1907), 3103.

³ *Ber.* **68** (1935), 952.

⁴ *Ber.* **40** (1907), 3103.

⁵ *Ber. Schimmel & Co.*, Oct. (1910), 106; April (1911), 105.

C. SESQUITERPENE ALCOHOLS

(a) ALIPHATIC SESQUITERPENE ALCOHOLS.

Farnesol

 $C_{15}H_{26}O$

Mol. Weight 222.36

3,7,11-Trimethyl-2,6,10-dodecatrien-1-ol

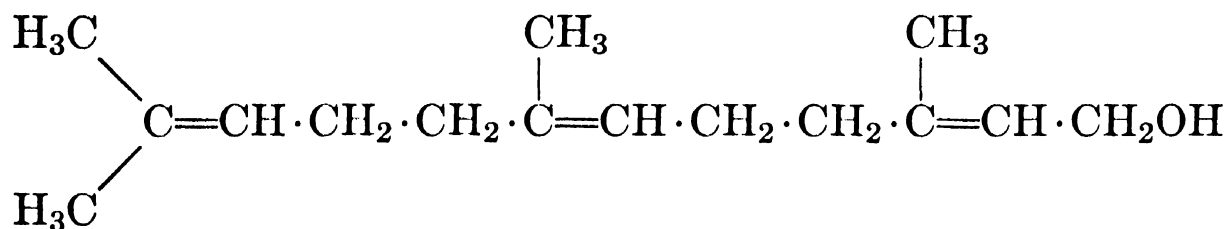

or

3,7,11-Trimethyl-2,6,11-dodecatrien-1-ol

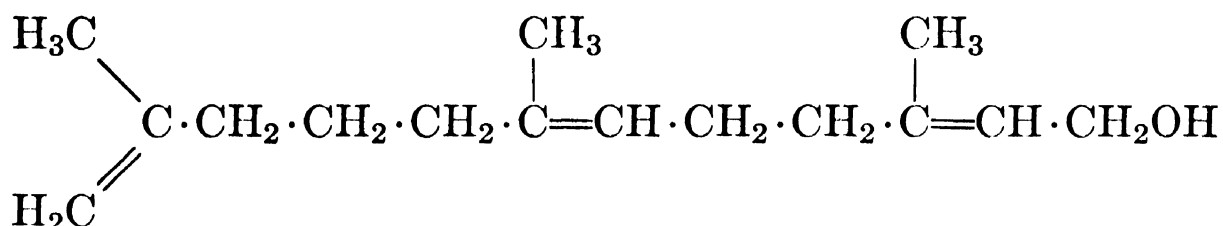

This acyclic primary sesquiterpene alcohol containing three ethylenic linkages consists undoubtedly of a mixture of the two structural isomers pictured above. According to Ruzicka,¹ each metamer may be a mixture of four theoretically possible stereoisomeric modifications so that farnesol could consist of eight isomeric alcohols. This may explain the fact that the various farnesols isolated from different sources show considerable variations in their physical properties.

Occurrence.—Farnesol occurs in several volatile oils and in extracted flower oils—for example, oil of ambrette seed, neroli bigarade, rose, cananga, Ceylon citronella, lemongrass, palmarosa, in Peru and tolu balsam oil, and the flower oils of acacia, reseda, cyclamen, jasmine, etc.

Isolation.—Farnesol can be isolated, for example, from ambrette seed oil as follows:

According to Harmann and Reimer,² the oil is fractionated *in vacuo*, the fraction b_{20} 150°–200° saponified, and treated with phthalic anhydride in benzene solution. As a primary alcohol, farnesol forms an acid phthalate from which it can be regenerated in pure form.

Identification.—Farnesol may be characterized by oxidation with chromic acid to farnesal $C_{15}H_{24}O$, b_{14} 173°–174°, d_{10} 0.893, n_D 1.4991. Farnesal can be identified by the preparation of its semicarbazone m. 133°–135°.

Lennartz³ has recently prepared the 3-nitroorthophthalate m. 93°–93.5° by long-time boiling of the alcohol with 3-nitroorthophthalic acid in benzene solution.

Späth and Vierhapper⁴ found the di- β -naphthylurethane m. 70°–71° suitable for identification of farnesol.

Properties.—Farnesol is a colorless, somewhat mobile oil with a pleasant floral odor reminiscent of lily of the valley.

As pointed out, the properties of farnesol show variations and depend upon its origin.

Illustrative figures reported by Kerschbaum,⁵ von Soden and Treff,⁶ Schimmel & Co.,⁷ Ruzicka,⁸ and Ruzicka and Firmenich⁹ are:

b_{10}	160° ⁵	d_4^{20}	0.8908 ⁸ (synthetic)
b_4	149° ⁶	d_4^{20}	0.8871 ⁹
b_{3-4}	140° – 141° ⁷	d_4^{18}	0.8954 ⁸
$b_{0.5}$	125° ⁸ (synthetic)	d_{18}	0.885 ⁵
$b_{0.3}$	120° ⁸	d_{15}^{15}	0.8934 ⁷
$b_{0.2}$	110° – 113° ⁹	d_{15}	0.894 ⁶
	n_D^{20}	1.4870 ⁹	
		1.4877 ⁸ (pure)	
		1.48991 ⁷	
		1.4890 ⁸ (synthetic)	
	n_D^{18}	1.4924 ⁸	

Lennartz¹⁰ reported these properties for a farnesol prepared by polymerization of isoprene:

$b_{0.02}$	106° – 112°
$d_4^{21.5}$	0.9004
$n_D^{21.5}$	1.4881

3-Nitrophthalate m. 93° – 93.5° .

On keeping for a long time, farnesol, according to Ruzicka,¹¹ slowly decomposes, thereby forming α -farnesene, a colorless mobile oil b_{12} 128° – 130° , d_4^{18} 0.8385, n_D 1.4965, which might be identical with sesquictronellene (see "Sesquictronellene").

On oxidation with potassium permanganate, farnesol is completely degraded, acetone being formed.

Use.—Farnesol is used in high-grade perfumes, especially in compositions of floral type.

¹ *Helv. Chim. Acta* **6** (1923), 495.

² German Patent No. 149,603.

³ *Ber.* **76B** (1943), 248, 831.

⁴ *Ber.* **71B** (1938), 1672.

⁵ *Ber.* **46** (1913), 1732.

⁶ *Ber.* **37** (1908), 1095.

⁷ *Ber. Schimmel & Co.*, April (1914), 71.

⁸ *Helv. Chim. Acta* **6** (1923), 492, 497.

⁹ *Ibid.* **22** (1939), 392.

¹⁰ *Ber.* **76B** (1943), 838.

¹¹ *Helv. Chim. Acta* **6** (1923), 498.

SUGGESTED ADDITIONAL LITERATURE

Y. R. Naves, "New Sources of Nerolidol and Farnesol," *Perfumery Essential Oil Record* **38**, No. 6 (1947), 191.

Nerolidol

C₁₅H₂₆O

Mol. Weight 222.36

3,7,11-Trimethyl-1,6,10-dodecatrien-3-ol

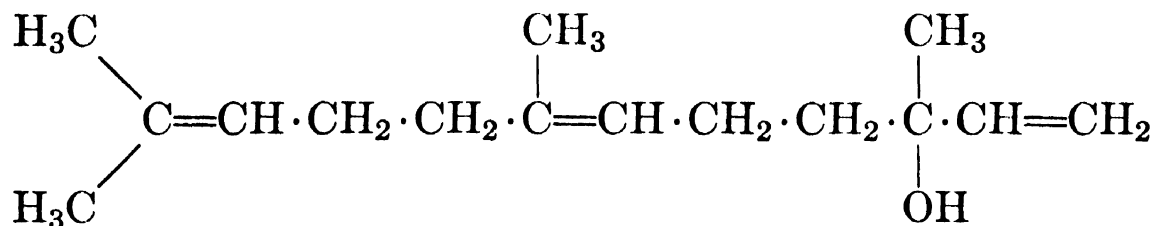

and

3,7,11-Trimethyl-1,6,11-dodecatrien-3-ol

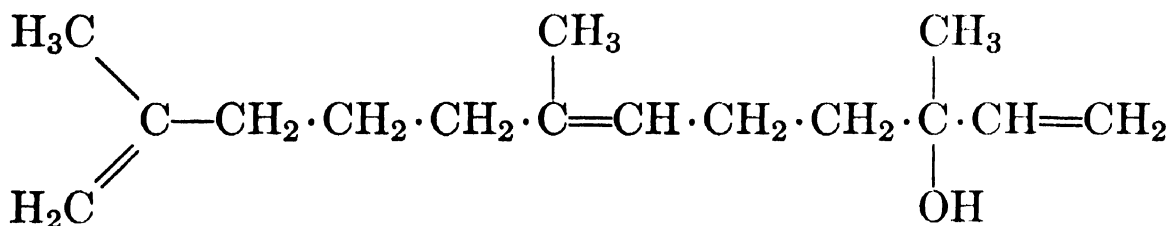

This sesquiterpene alcohol may be viewed as the "linalool of the sesquiterpene series."

Occurrence.—Nerolidol occurs in oil of neroli bigarade, in balsam Peru oil, in oil of ylang ylang and in several other volatile oils. Oil of cabreuva (probably *Myrospermum erythroxyton* Fr. Allem.) contains 75–80 per cent of nerolidol.

Isolation.—In order to isolate nerolidol from balsam Peru oil, or from neroli bigarade oil, Schimmel & Co.¹ suggested saponifying the high boiling fractions of the oil with alcoholic potassium, and fractionating *in vacuo* the sesquiterpene alcohols thus obtained.

Divide 5 kg. of balsam Peru into three portions of 1½ kg. each, and dissolve each portion in 1.5 liters alcohol. Add to each portion 800 g. of a concentrated potassium hydroxide solution (3 parts of potassium hydroxide in 2 parts of water), shake and heat on a steam bath for several hours. Remove the ethyl alcohol by steam distillation, and extract the residue repeatedly with ether. According to Ruzicka,² this treatment will yield altogether about 1 kg. of a brown oil which, on fractionation b_{0.4} 98°–102°, will give 94 g. of a fraction consisting of nerolidol.

Identification.—*d*-Nerolidol can be characterized by the preparation of its phenylurethane m. 37°–38°. According to Schimmel & Co.,³ this compound, however, is formed only if the *d*-nerolidol is kept standing with phenylisocyanate for three to four weeks.

dl-Nerolidol, on oxidation with chromic acid mixture, yields farnesal which, in turn, is identified by the preparation of its semicarbazone, m. 133°, according to Ruzicka.⁴

Properties.—Nerolidol is a syrupy oil of a faint, agreeable floral note. The following properties, reported by Hesse and Zeitschel,⁵ Ruzicka,^{6,7} and Jones and Harvey,⁸ are characteristic of the isomeric forms whether chemically derived or originating from neroli, Peru balsam or Melaleuca oil:

	<i>d</i>	<i>l</i>		<i>dl</i>
b.	276°–277° ⁵
b ₃	110° ⁸
b _{0.2}	96°–98° ⁶	...	b _{0.3}	98°–100° ⁷
d ₄ ²²	0.8778 ⁶
d _{15.5}	0.8816 ⁸	...	d ₄ ¹⁶	0.8788 ⁷
α _D	+13° 32' ⁵
	+13° 36' ⁶
[α] _D	+15° 30' ⁶
n _D ²²	1.4786 ⁶
n _D ²⁰	1.4795 ⁸
n _D ¹⁶		1.4801 ⁷

Use.—Nerolidol is used in small quantities for the compounding of high-grade perfume compositions.

¹ *Ber. Schimmel & Co.*, April (1914), 75.

² *Helv. Chim. Acta* **6** (1923), 483, 488, 492.

³ *Ber. Schimmel & Co.*, April (1914), 76.

⁴ *Helv. Chim. Acta* **6** (1923), 483, 488, 492.

⁵ *J. prakt. Chem.* [2], **66** (1902), 503.

⁶ *Helv. Chim. Acta* **6** (1923), 483, 501.

⁷ *Ibid.*, 501.

⁸ *Proc. Roy. Soc. Queensland* **47** (1936), 92. *Chem. Abstracts* **31** (1937), 1957.

SUGGESTED ADDITIONAL LITERATURE

Y. R. Naves, "Etudes sur les matières végétales volatiles. Présence de nérolidol dans les huiles essentielles de papilionacées," *Helv. Chim. Acta* **30** (1947), 275, 278.

Y. R. Naves, "New Sources of Nerolidol and Farnesol," *Perfumery Essential Oil Record* **38**, No. 6 (1947), 191.

Y. R. Naves, "Présence de Nérolidol dans les huiles essentielles de papilionacées," *Helv. Chim. Acta* **31** (1948), 408.

(b) MONOCYCLIC SESQUITERPENE ALCOHOLS.

Zingiberol



Mol. Weight 222.36

This sesquiterpene alcohol was isolated by Brooks¹ from ginger root oil. Zingiberol b_{14.5} 154°–157° is apparently a derivative of zingiberene or iso-

zingiberene. On dehydration, zingiberol yields a hydrocarbon $C_{15}H_{24}$ which, in turn, gives zingiberene dihydrochloride (or isozingiberene dihydrochloride) when treated with hydrogen chloride.

¹ *J. Am. Chem. Soc.* **38** (1916), 430.

Elemol

$C_{15}H_{26}O$

Mol. Weight 222.36

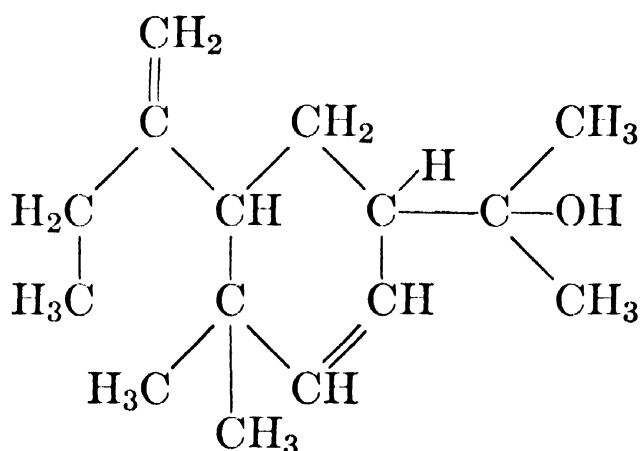

Occurrence.—Elemol occurs in the high boiling fractions of Manila elemi oil and Java citronella oil.

Isolation.—By fractional distillation. The alcohol can be purified according to Ruzicka and Pfeiffer¹ by benzylation, fractionation of the benzoate at 0.25 mm. pressure, and saponification of the benzoate.

Elemol may also be purified through its crystalline phenylurethane, but the alcohol regenerated from it has a somewhat higher melting point than that obtained from the benzoate (see Ruzicka and van Veen²).

Doll and Nerdel³ published directions for isolation of this alcohol by means of the *p*-nitrobenzoate and the 3,5-dinitrobenzoate. Both were obtained in good yields from the original oils. For the isolation of elemol from citronella oil, the alcohol was first extracted from the elemol-containing fraction of the oil through the borate. Then 500 g. of the crude elemol thus obtained were dissolved in 2 liters of pyridene, treated with 500 g. of *p*-nitrobenzoyl chloride, and allowed to stand for 24 hr. at room temperature. The *p*-nitrobenzoate of elemol, fractionally recrystallized from alcohol and petroleum ether, melted at 74°–76°, $[\alpha]_D -2^\circ 40'$ (in benzene), $-7^\circ 48'$ (in chloroform). The 3,5-dinitrobenzoate of elemol melted at 122°–123°, $[\alpha]_D \pm 0^\circ$ (in benzene), $-10^\circ 0'$ (in chloroform).

The elemol is regenerated from these compounds by boiling the nitrobenzoates for 30 min. with an excess of alkali in methyl alcohol.

Identification.—Elemol can be characterized by the preparation of the nitrobenzoates as described above or, according to Glichitch,⁴ by the preparation of the phenylurethane m. 112°–113°.

Properties.—When purified through the phenylurethane, elemol has these properties, according to Ruzicka and van Veen:⁵

m.	51°–52°	d_4^{15}	0.9400
b_{15}	144°–145°	n_D^{15}	1.5042

Doll and Nerdel ⁶ reported for elemol isolated and purified through the nitrobenzoates:

m.	52°	d_{15}^{55}	0.922
b_6	133°	$[\alpha]_D$	-9° 35' (in benzene)
		$[\alpha]_D$	-4° 21' (in chloroform)

As a tertiary alcohol, elemol does not react with phthalic anhydride. On dehydrogenation with selenium, elemol yields eudalene and some azulene.

Use.—Elemol, as such, is not used in our industries, but the fractions of oil of elemi and citronella containing elemol find considerable application in the scenting of soaps and all kinds of technical products. Because of high boiling points, these fractions act as odor fixatives.

¹ *Helv. Chim. Acta* **9** (1926), 841.

⁴ *Parfums France* **4** (1926), 256.

² *Liebigs Ann.* **476** (1929), 88.

⁵ *Liebigs Ann.* **476** (1929), 88.

³ *Ber. Schimmel & Co.* (1940), 46.

⁶ *Ber. Schimmel & Co.* (1940), 46.

(c) BICYCLIC SESQUITERPENE ALCOHOLS.

Sesquibenihiol

$C_{15}H_{24}O$

Mol. Weight 220.34

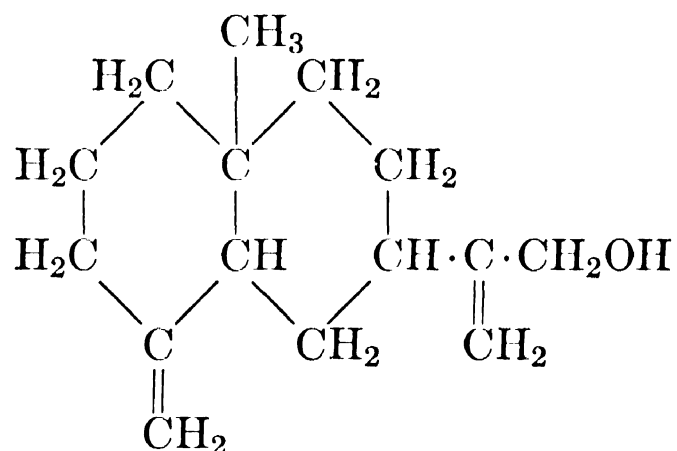

Occurrence.—In the volatile oil distilled from the root of *Chamaecyparis formosensis* Matsum.

Isolation.—By repeated fractionation of the oil.

Identification.—The ozonization product of sesquibenihiol, according to Katsura,¹ is a monoketomonocarboxylic acid $C_{12}H_{18}O_3$, the methyl ester of which yields a semicarbazone m. 235°–237°.

Properties.—The same author reported these properties for sesquibenihiol:

b_3	137°	$[\alpha]_D$	+8° 50'
d_4^{18}	0.9977	n_D	1.5220

Use.—Sesquibenihiol as such is not used in our industries.

¹ *J. Chem. Soc. Japan* **63** (1942), 1460, 1465. *Chem. Abstracts* **41** (1947), 3447.

The Betulenols

(Betulol)

 $C_{15}H_{24}O$

Mol. Weight 220.34

Von Soden and Elze¹ first isolated from the leaf bud oil of *Betula alba* L. a bicyclic primary sesquiterpene alcohol containing two ethylenic linkages which they named "betulol." The alcohol was also investigated by Semmler, Jonas and Richter,² and by Schimmel & Co.,³ but its constitution was not determined. More recently Treibs⁴ showed that the volatile leaf bud oil of Russian *Betula lenta* L. consists mainly of three closely related sesquiterpene alcohols all of empirical formulas $C_{15}H_{24}O$, which he designated α -, β - and γ -betulenol. The old term "betulol," according to Treibs, is now untenable, as these alcohols more closely resemble a sesquiterpene $C_{15}H_{24}$ that has been found in birch bud oil and which is itself closely related to caryophyllene. The term "betulenene" should be applied, according to Treibs, to the hydrocarbon $C_{15}H_{22}$ that has also been isolated from the oil. Thus, these sesquiterpene alcohols $C_{15}H_{24}O$ from the $C_{15}H_{24}$ birch hydrocarbons then become *betulenols* and those closely related to $C_{15}H_{22}$ should be named *betulenenols*. The name "betulene" should be restricted for the $C_{15}H_{24}$ product.

Occurrence.—The betulenols occur free and as esters in the volatile oil distilled from the leaf buds of the birch. Treibs⁵ found that this oil contains 16 per cent free, and 34 per cent esterified, betulenols.

Isolation.— α - and β -Betulenol readily form acid phthalates, but the γ - isomer does not react with phthalic anhydride. α -Betulenol is most readily attacked; thus treatment of a betulenol mixture with an insufficient amount of phthalic anhydride for complete esterification yields the α - derivative. A secondary reaction after removal of the α - ester yields the acid phthalate of β -betulenol and the γ - is isolated from the oily residue. The sesquiterpene alcohols may be regenerated from the phthalates.

Identification.—The betulenols can be characterized by their physical properties and by the products of oxidation. On vigorous oxidation all three betulenols are oxidized to the same monocyclic dicarboxylic acid $C_{10}H_{16}O_4$, viz., betulenolic acid, a viscous oil, which forms a dimethyl ester b_{20} 140° – 145° , d_{15} 1.041, α_D $+49^{\circ} 0'$, n_D 1.4506. Betulenolic acid is identical with naturally derived homocaryophyllenic acid, and may be characterized through conversion of its dimethyl ester into *cis*- and *trans*-dianilides m. 180° and 279° (cf. Ramage and Simonsen⁶).

Properties.—The physicochemical properties, especially the optical rotation, of "betulol" reported by the earlier investigators differ considerably from those recorded by Treibs.⁷ These variations might have been due either to different methods of working up the original birch bud oil, or to the

presence in varying proportions of several closely related compounds in the so-called pure "betulol," a fact proved later by Treibs.⁸ This author reported for the betulenol isomers:

	b_{20}	d_{15}	n_D	α_D
α -Betulenol	154°–156°	0.978	1.5148	–19° 30'
β -Betulenol	155°–157°	0.975	1.5132	–36° 0'
γ -Betulenol	157°–158°	0.969	1.5102	–19° 30'

Use.—Betulenol is not used in our industries.

¹ *Ber.* **38** (1905), 1636.

² *Ber.* **51** (1918), 417.

³ *Ber. Schimmel & Co.* (1918), 8.

⁴ *Ber.* **69** (1936), 41; **71** (1938), 612.

⁵ *Ibid.*

⁶ *J. Chem. Soc.* (1937), 74.

⁷ *Ber.* **69** (1936), 41; **71** (1938), 612.

⁸ *Ber.* **71** (1938), 614.

The Santalols

$C_{15}H_{24}O$

Mol. Weight 220.34

Santalol, the main constituent of East Indian sandalwood oil, consists of a mixture of two primary sesquiterpene alcohols, viz., α - and β -santalol, the α - form predominating. The santalols have been the subject of thorough investigations by prominent authorities, among them Semmler,¹ Ruzicka,² Simonsen and collaborators.³

Being primary alcohols, α - and β -santalol react with phthalic anhydride in benzene solution. The "santalol" resulting from the hydrolysis of the acid phthalates, on fractional distillation, yields fractions with different rotatory powers, but the α - and β -santalols cannot be completely separated by ordinary distillation methods.

α -Santalol $C_{15}H_{24}O$

Mol. Weight 220.34

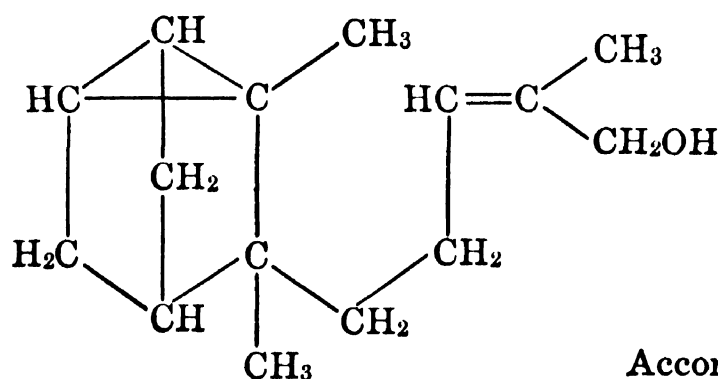
According to Semmler⁴

OR

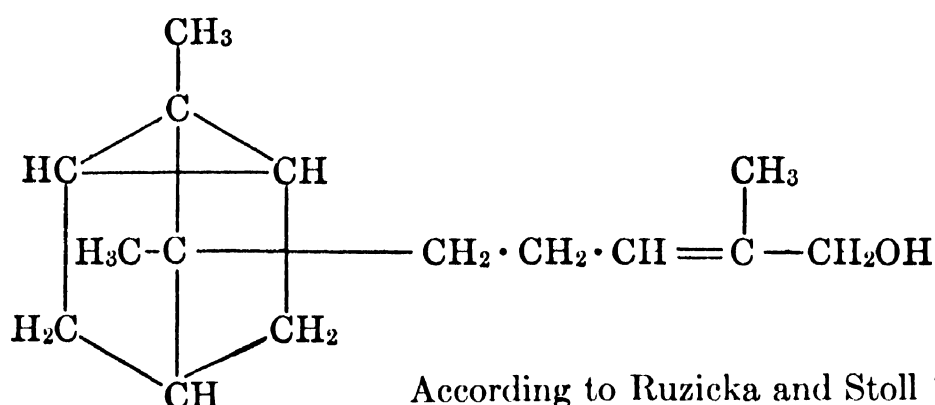
According to Ruzicka and Stoll¹

Occurrence.— α -Santalol is the main constituent of East Indian sandalwood oil; it has been observed also in West Australian sandalwood oil.

Isolation.—In order to isolate the crude santalols (mixture of α - and β -santalol), 6 kg. of sandalwood oil are mixed with a solution of 0.6 kg. of potassium hydroxide (or the equivalent quantity of sodium hydroxide) in 2 kg. of 90% alcohol and heated on the steam bath for 2 to 3 hr. The saponified oil is washed with water and repeatedly fractionated *in vacuo*.⁵

For further purification of the santalols (mixture of α - and β -santalol), Schimmel & Co.⁶ suggested the following method:

Digest 100 g. of East Indian sandalwood oil, 100 g. of phthalic anhydride, and 100 g. of benzene for one hour on the steam bath at 80°. Shake the acid esters thus formed with a soda solution, and dissolve the alkali salt in a large quantity of water. In order to remove the nonalcoholic constituents, extract the aqueous solution three times with ether. Liberate the acid esters by acidification with dilute sulfuric acid (a little more than theoretically required), separate and saponify with alcoholic potassium. Purify the santalol thus liberated by washing with water in order to remove any excess alkali and alcohol.

It is not possible to obtain α -santalol in pure form by ordinary fractional distillation, α -santalol boiling only about 10° lower than β -santalol. However, Bradfield, Penfold and Simonsen⁷ report the isolation of santalols of high purity through the use of a still head of special design (see Bradfield⁸), the progress of the separation being followed by observation of the optical rotation and by oxidation with percamphoric acid (cf. Milas and Cliff⁹).

These authors discourage the use of the strychnine salts of the acid phthalates as practiced by Paolini and Divizia.¹⁰ Their experience shows this method to be of little value, except in final purification, as mixed crystals are formed.

Tsukamoto and Ichibashi¹¹ suggested separating α - and β -santalol by the following method:

Boil a mixture of sandalwood oil, ether and mercuric acetate solution for several days. Isolate the mercuric compound of β -santalol by the addition of sodium carbonate or sodium chloride, purify the mercuric compound and regenerate β -santalol by the action of hydrogen sulfide. The mercuric compound of α -santalol remains in the ether layer. Decompose this compound with hydrogen sulfide and separate the α -santalol.

Identification.— α -Santalol can be characterized by several methods:

(1) According to Semmler and Bode,¹² by oxidation with chromic acid to santalaldehyde (santalal) $C_{15}H_{22}O$, b_{10} 152° – 155° , d_{20} 0.995, α_D $+13^{\circ} 0'$, n_D 1.51066. This aldehyde may be identified by the preparation of its semicarbazone m. 230° . (Schimmel & Co.¹³ observed on several occasions m. 215° – 219° .)

(2) By the preparation of derivatives:

(a) Allophanate m. 162° – 163° , according to Bradfield, Penfold and Simonsen.¹⁴

(b) Strychnine salt of the acid phthalate m. 144° – 145° , $[\alpha]_{5461}$ $-5^{\circ} 37'$ ($c = 4.68$ in benzene), by the same authors.

(c) Monosantalyl mucate m. 136° , by Kariyone and Morotomi.¹⁵

Properties.—When purified by a special fractionation method *in vacuo* and in an atmosphere of carbon dioxide, α -santalol, according to Bradfield, Penfold and Simonsen,¹⁶ has these properties:

b_{14}	166° – 167°	α_{5461}	$+10^{\circ} 18'$
d_{25}^{25}	0.9770	n_D^{25}	1.5017

These properties are similar to those reported by Guha and Bhattacharyya¹⁷ both for α -santalol from Indian sandalwood and that from *d*-tricycloekasantalol:

d- α -Santalol

<i>Synthetic</i>		<i>Natural</i>	
b_5	148°	b_5	148°
		b_4	145°
$[\alpha]_{5780}$	$+9^{\circ} 36'$	$[\alpha]_{5780}$	$+9^{\circ} 1'$
$[\alpha]_{5460}$	$+11^{\circ} 6'$	$[\alpha]_{5460}$	$+10^{\circ} 24'$

Properties previously reported by Paolini and Divizia,¹⁸ by Guerbet,¹⁹ and by von Soden²⁰ must be regarded as those pertaining to mixtures. This is evidenced by the low optical rotation observed by these workers.

Semmler and Bode²¹ found that, on oxidation with potassium permanganate in acetone solution, α -santalol yields mainly tricycloekasantalic acid $C_{10}H_{16}O_2$, m. 71° – 72° , a reaction which may serve also for the characterization of α -santalol.

According to Ruzicka and Stoll,²² α -santalol is a derivative of eudalene; in fact, α -santalol stands between eudalene and cadalene.

 β -Santalol $C_{15}H_{24}O$

Mol. Weight 220.34

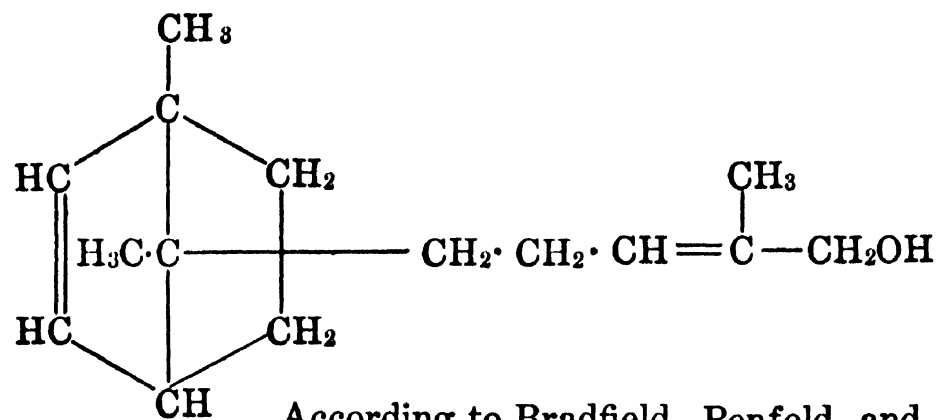

or

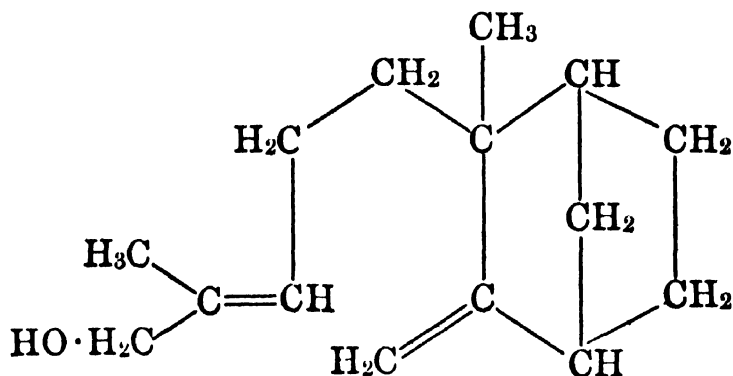

Occurrence.—In the santalol fraction of East Indian sandalwood oil.

Isolation.—By special means of fractional distillation (see also " α -Santalol").

Identification.—(1) According to Bradfield, Penfold and Simonsen,²⁵ the allophanate melts at 159°–160°.

(2) The strychnine salt of the acid phthalate, according to the same authors, melts at 134°–135°, $[\alpha]_{5461} -37^{\circ} 30'$ ($c = 2.68$ in benzene).

Properties.—When purified first by a special fractionation method and in an atmosphere of carbon dioxide, and subsequently through the strychnine salt of its acid phthalate, β -santalol, according to Bradfield, Penfold and Simonsen,²⁶ had these properties:

b_{17}	177°–178°	α_{5461}	–87° 6'
d_{25}^{25}	0.9717	n_D^{25}	1.5100

β -Santalol is a derivative of cadalene.

Use.—The medicinal value of sandalwood oil is due mainly to the santalols.

¹ *Ber.* **40** (1907), 1132; **43** (1910), 1893; **46** (1913), 2306.

² *Helv. Chim. Acta* **18** (1935), 355.

³ *J. Chem. Soc.* (1935), 309.

- ⁴ These formulas are structurally identical and differ only in their spatial arrangement.
- ⁵ Heine & Co., German Patent No. 110,485, Jan. 4, 1898.
- ⁶ *Ber. Schimmel & Co.*, April (1899), 43.
- ⁷ *J. Chem. Soc.* (1935), 309.
- ⁸ *J. Soc. Chem. Ind.* **54** (1935), 6T.
- ⁹ *J. Am. Chem. Soc.* **55** (1933), 352.
- ¹⁰ *Atti accad. Lincei* [5], **23** (1914), II, 226. *Chem. Abstracts* **9** (1915), 1324.
- ¹¹ *J. Pharm. Soc. Japan* **48** (1928), 416. See also *Pharm. J.* **123** (1929), 420.
- ¹² *Ber.* **40** (1907), 1126, 1127.
- ¹³ *Ber. Schimmel & Co.*, April (1921), 44.
- ¹⁴ *J. Chem. Soc.* (1935), 309. See also Penfold, *J. Proc. Royal Soc. N. S. Wales* **62** (1928), 60; **66** (1932), 240.
- ¹⁵ *J. Pharm. Soc. Japan* **49** (1929), 170.
- ¹⁶ *J. Chem. Soc.* (1935), 309.
- ¹⁷ *J. Indian Chem. Soc.* **21** (1944), 267, 284.
- ¹⁸ *Atti accad. Lincei* [5], **23** (1914), II, 226. *Chem. Abstracts* **9** (1915), 1324.
- ¹⁹ *Compt. rend.* **130** (1900), 1326.
- ²⁰ *Arch. Pharm.* **238** (1900), 362.
- ²¹ *Ber.* **40** (1907), 1133.
- ²² *Helv. Chim. Acta* **5** (1922), 923. See also *Ber. Schimmel & Co.* (1923), 185; (1936), 75.
- ²³ *J. Chem. Soc.* (1935), 309.
- ²⁴ *Helv. Chim. Acta* **18** (1935), 355.
- ²⁵ *J. Chem. Soc.* (1935), 314.
- ²⁶ *Ibid.*, 310.

The Fusanols

C₁₅H₂₄O

Mol. Weight 220.34

The constitution of these probably bicyclic sesquiterpene alcohols containing two ethylenic linkages remains obscure, although studies have been made as to their individual identity by Rao and Sudborough,¹ May,² Penfold,³ Venkatesaiya and Watson,⁴ Simonsen,⁵ and Youngken.⁶

Occurrence.—In West Australian sandalwood oil (*Eucarya spicata* Spr. and Summ., syn. *Fusanus spicatus* Br., *Santalum spicatum* D.C., *S. cygnorum* Mig.) (cf. Marr,⁷ and Penfold⁸).

Isolation.—Rao and Sudborough⁹ originally reported the isolation of the “fusanols” through their acid phthalates; they thus separated the alcohol mixture by fractional distillation into α - and β -fusanol.

Identification.—According to Penfold,¹⁰ the fraction rich in “fusanols” yields an allophanate m. 148°–152°. The fusanols do not yield santalenic acid upon oxidation.

Properties.—Rao and Sudborough observed these properties:

<i>α-Fusanol</i>			
b ₅	146°–149°	[α] _D ²⁵	+5° 42'
d ₁₅ ¹⁵	0.9775	n _D ²⁵	1.5060
<i>β-Fusanol</i>			
b ₅	153°–155°	[α] _D ²⁵	+2° 36'
d ₁₅ ¹⁵	0.9753	n _D ²⁵	1.5100

The meager physical data available to characterize these isomeric sesquiterpene alcohols leave still some doubt as to their individuality.

Since they reacted with phthalic anhydride in benzene solution, they are most likely not secondary alcohols as suggested by these authors. In fact a reinvestigation of West Australian sandalwood oil by Penfold¹¹ showed that the alcohol fraction consisted of a mixture of primary and secondary alcohols. The primary alcohols contained santalols (allophanate m. 162°–163°), and another alcohol b_{4-5} 160°–161°, d_{20} 0.942, $\alpha_D \pm 5^\circ 0'$, n_D^{20} 1.5030. It is possible that the fusanols of Rao and Sudborough¹² were a mixture of this alcohol and the santalols.

Penfold¹³ also described a strongly laevorotatory alcohol isolated primarily from oil of *Santalum lanceolatum* b_5 163°–165°, d 0.9474, $\alpha_D -66^\circ 42'$, n_D^{20} 1.5074; allophanate m. 114°. Venkatesaiya and Watson,¹⁴ and Jones and Smith,¹⁵ too, observed the presence of an alcohol with high laevorotation and boiling higher than santalol in the West Australian oil. This product was subsequently shown by Bradfield, Francis, Penfold and Simonsen¹⁶ to be identical with a primary sesquiterpene alcohol from *Santalum lanceolatum* which they named lanceol.

The secondary alcohol mentioned above yielded an acid phthalate at 140°, and after reconversion had these properties:

b_1	146°–150°	α_D	+27° 12'
d_{15}^{15}	0.995	n_D^{20}	1.5100

The chemistry of these alcohols is apparently still under investigation by Penfold.¹⁷

Use.—The fusanols, as such, are not used in our industries.

¹ *J. Ind. Inst. Sci.* **5** (1922), 163.

² *Pharm. J.* **120** (1928), 368.

³ *J. Proc. Roy. Soc. N. S. Wales* **62** (1928), 60.

⁴ *J. Soc. Chem. Ind.* **47** (1928), 322T.

⁵ "The Terpenes," Vol. II (1931), 591.

⁶ *Am. Perfumer* **42**, March (1941), 36.

⁷ *Chemist Druggist* **113** (1930), 821.

⁸ *J. Proc. Roy. Soc. N. S. Wales* **66** (1932), 240.

⁹ *J. Ind. Inst. Sci.* **5** (1923), 163.

¹⁰ *J. Proc. Roy. Soc. N. S. Wales* **62** (1928), 60.

¹¹ *Ibid.*, **70**; **66** (1932), 242.

¹² *J. Ind. Inst. Sci.* **5** (1923), 163.

¹³ *J. Proc. Roy. Soc. N. S. Wales* **62** (1928), 60.

¹⁴ *J. Soc. Chem. Ind.* **47** (1928), 322T.

¹⁵ *Proc. Roy. Soc. Queensland* **41** (1929), 17. *Chem. Abstracts* **24** (1930), 3604.

¹⁶ *J. Chem. Soc.* (1936), 1619.

¹⁷ *Australasian J. Pharm.* (1937), 154.

Sesquiterpene Alcohols from Camphor Oil

(Sesquicamphenol)

$C_{15}H_{24}O$ Mol. Weight 220.34

$C_{15}H_{26}O$ Mol. Weight 222.36

The sesquiterpene alcohol $C_{15}H_{26}O$, first described by Semmler and Rosenberg¹ and named sesquicamphenol, was shown by Ruzicka and Stoll² to consist of a mixture of one primary, two secondary, and two tertiary alcohols.

Occurrence.—In the high boiling fraction of camphor oil.

Isolation.—By treatment of the fraction b_{12} 140° – 170° with phthalic anhydride, and by preparing the benzoate b_2 175° – 176° from the fraction b_{12} 145° – 165° . Thus the primary alcohol was separated from the secondary and tertiary alcohols by treatment with phthalic anhydride in benzene solution. It is probably bicyclic. The secondary alcohols were separated by treatment with phthalic anhydride at 130° . They consisted apparently of two bicyclic alcohols, viz., $C_{15}H_{26}O$ and $C_{15}H_{24}O$. The tertiary alcohols which did not react with phthalic anhydride were purified by the preparation of the benzoate and by hydrolysis. The mixture of tertiary alcohols consisted of at least two bicyclic alcohols.

Identification.—Through determination of the properties.

Properties.—Ruzicka and Stoll³ reported for their sesquiterpene alcohols isolated from camphor oil:

(1) Primary bicyclic alcohol $C_{15}H_{26}O$.

A colorless viscid oil having these properties:

b_{12}	158° – 159°
d_4^{14}	0.9566
n_D^{14}	1.5020

On dehydrogenation with sulfur, this primary alcohol does not yield a naphthalene hydrocarbon.

(2) Secondary bicyclic alcohols $C_{15}H_{26}O$ and $C_{15}H_{24}O$.

A colorless viscid oil which had these properties:

b_{12}	154° – 155°	$C_{15}H_{26}O$:	b_{12}	160° – 162°
d_4^{16}	0.9608	$C_{15}H_{24}O$:	b_{12}	154° – 155°
n_D^{16}	1.5054			

On dehydrogenation with sulfur, this mixture of unsaturated secondary alcohols yields cadalene. At least one of these alcohols, therefore, belongs to the cadinene type. $C_{15}H_{28}O$ is obtained upon hydrogenation.

(3) Tertiary bicyclic alcohol $C_{15}H_{26}O$.

A colorless viscid oil which after purification through the benzoate had these properties:

b_{12}	156°
d_4^{20}	0.9665
n_D^{20}	1.5050

On dehydrogenation with sulfur, this mixture of tertiary alcohols yields both cadalene and eudalene; therefore, the mixture must consist of at least two alcohols which belong to the cadinene and eudesmol type.

Komatsu, Fujimoto and Tanaka ⁴ isolated from blue camphor oil a tertiary sesquiterpene alcohol $C_{15}H_{26}O$ for which they suggested the following formula:

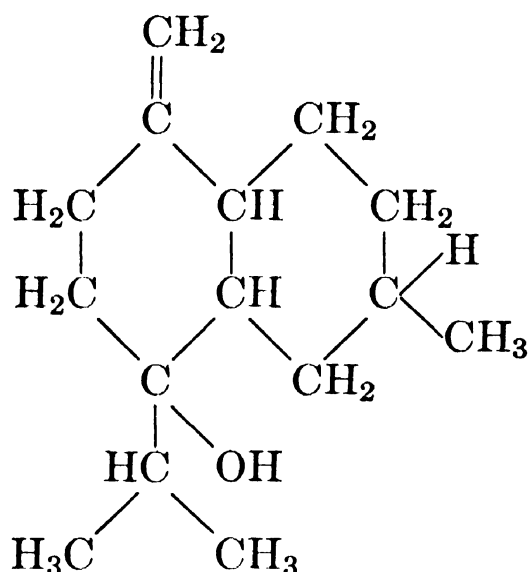

Except for the similarity in their boiling points (see "Properties") there is no indication that this alcohol is identical with any of the above described tertiary sesquiterpene alcohols of Ruzicka and Stoll.⁵

The tertiary sesquiterpene alcohol of Komatsu, Fujimoto and Tanaka ⁶ had these properties:

b_{12}	$157^{\circ}-160^{\circ}$	$[\alpha]_D$	$+35^{\circ} 30'$
d_4^{25}	0.9501	n_D^{25}	1.5040

On dehydrogenation with sulfur it yields cadalene.

A few years earlier, Ono ⁷ had isolated from the high boiling fractions of camphor oil a bicyclic sesquiterpene alcohol $C_{15}H_{26}O$ with these properties:

b_{10}	$170^{\circ}-174^{\circ}$
$[\alpha]_D$	$+66^{\circ} 35'$
n_D^{14}	1.5084

(Regarding a secondary, tricyclic sesquiterpene alcohol $C_{15}H_{26}O$, see "Shojunol.")

Use.—The sesquiterpene alcohols of camphor oil are not used as such in our industries but the high boiling fractions of camphor oil in which these alcohols occur serve widely for the scenting of all kinds of technical products.

¹ *Ber.* **46** (1913), 770.

² *Helv. Chim. Acta* **7** (1924), 260.

³ *Ibid.*, 267, 269.

⁴ *J. Chem. Soc. Japan* **51** (1930), 498.

⁵ *Helv. Chim. Acta* **7** (1924), 260.

⁶ *J. Chem. Soc. Japan* **51** (1930), 498.

⁷ *Mem. Coll. Sci. Kyoto* **8**[A] (1925), 1. *Chem. Abstracts* **20** (1926), 1987.

Cymbopol

C₁₅H₂₆O

Mol. Weight 222.36

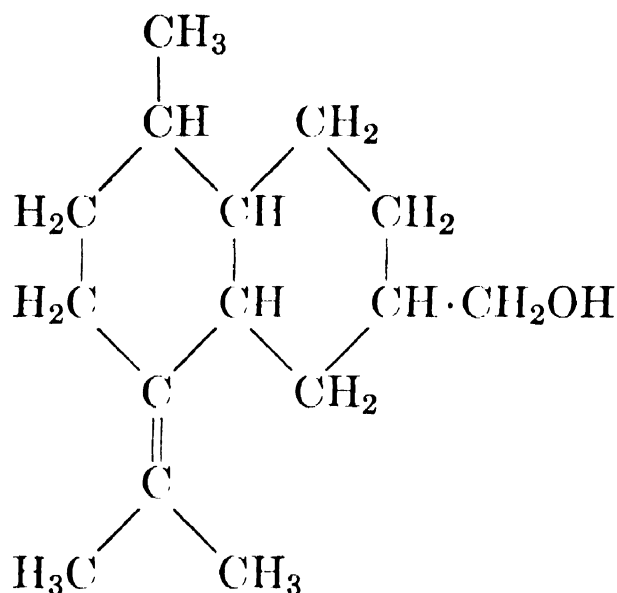

According to Kafuku, Ikeda and Fujita,¹ the high boiling fractions (15 per cent) of the oil of Java type citronella cultivated in Formosa contain 10 per cent of a primary sesquiterpene alcohol C₁₅H₂₆O, viz., cymbopol, which has these properties:

b ₇₅₉	292°	α _D ²²	-8° 24'
d ₄ ³⁰	0.9515	n _D ³⁰	1.495

These authors established the above-pictured structural formula for cymbopol.

Aside from 10 per cent cymbopol, the high boiling fractions of Formosa citronella oil Java type contain 15 per cent geraniol, 15 per cent γ-cadinene, 50 per cent elemol, and 10 per cent γ-cadinol.

¹ *J. Chem. Soc. Japan* **53** (1932), 645. *Chem. Abstracts* **27** (1933), 280.

Eudesmol

(Selinelol)

 $C_{15}H_{26}O$

Mol. Weight 222.36

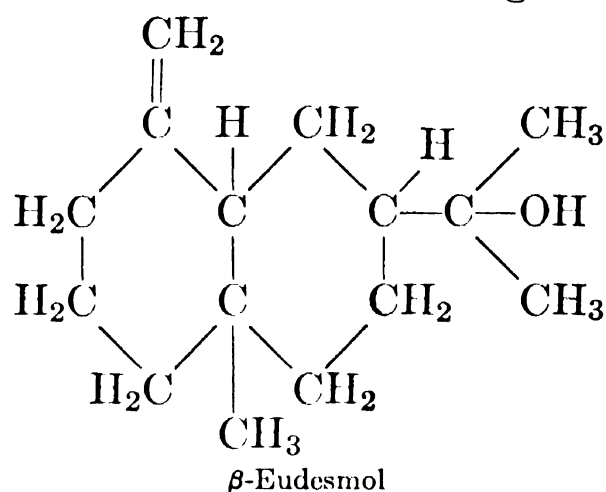
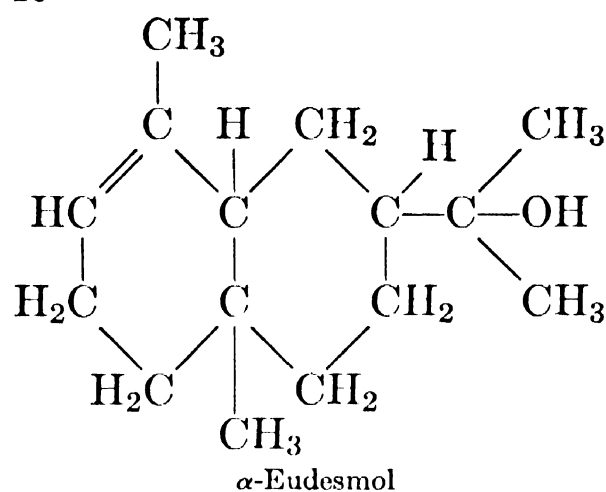

The structural formula of this bicyclic, tertiary sesquiterpene alcohol containing one ethylenic linkage was established by Ruzicka and collaborators.¹ Although apparently homogeneous, eudesmol is a mixture of isomers.

Occurrence.—Eudesmol has been identified in the oils distilled from several species of eucalyptus, the best source for its isolation being the oil of *E. macarthurii*.

Isolation.—By fractional distillation of the oil derived from *E. macarthurii*.

Identification.—When treated with hydrogen chloride in acetic acid or ethereal solution, eudesmol yields a dihydrochloride m. 74° – 75° , $[\alpha]_D^{20} +20^{\circ} 0'$ (in chloroform). This compound is identical with selinene dihydrochloride (see "Selinene"). Reduction yields a dihydro derivative m. 84° – 85° , $[\alpha]_D^{20} +17^{\circ} 0'$ (in chloroform), according to Ruzicka, Wind and Koolhaas.² The allophanate m. 174° likewise may be used to characterize this compound.

Properties.—Semmler and Tobias³ reported these characteristic properties for eudesmol:

m.	78°	$[\alpha]_D^{20}$	$+31^{\circ} 21'$ (in 12% chloroform
b_{10}	156°		solution)
d_{20}	0.9884	n_D^{20}	1.516

On dehydrogenation with sulfur or selenium, eudesmol yields eudalene.

On acetylation, eudesmol forms eudesmyl acetate b_{11} 165° – 170° , d_{20} 0.9933, $[\alpha]_D^{20} +31^{\circ} 0'$, n_D^{20} 1.49204.

Use.—Eudesmol, as such, is not used in our industries.

¹ *Helv. Chim. Acta* **5** (1922), 362; **14** (1931), 1132. *Liebigs Ann.* **453** (1927), 62.

² *Helv. Chim. Acta* **14** (1931), 1140, 1143.

³ *Ber.* **46** (1913), 2026.

SUGGESTED ADDITIONAL LITERATURE

Pl. A. Plattner, A. Fürst and J. Hellerbach, "Über einige Abbauprodukte des Eudesmols," *Helv. Chim. Acta* **30** (1947), 2158.

Torreyol

C₁₅H₂₆O

Mol. Weight 222.36

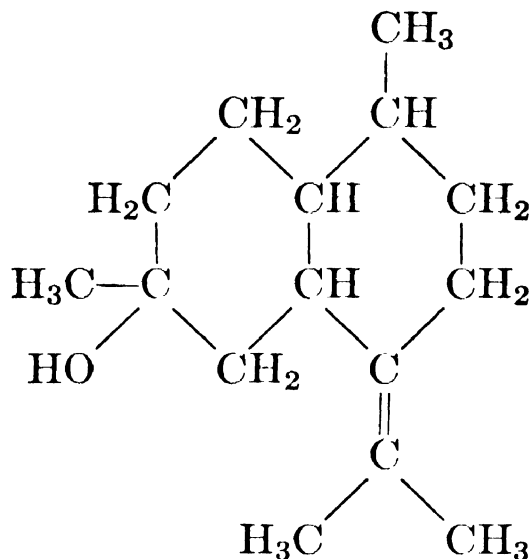

This structural formula of torreyol was suggested by Nisida and Uota.¹
Occurrence.—Torreyol occurs in the oil obtained by steam distillation from the leaves of *Torreya nucifera*.

Isolation.—By fractional distillation. Torreyol can be purified by sublimation.

Properties.—Nisida and Uota² reported these properties for torreyol:

m.	139°–140°
[α] _D	+107° 8'

On oxidation with potassium permanganate in benzene solution, torreyol yields a dihydroxy derivative C₁₅H₂₈O₃, m. 78°–79°, [α]_D –11° 19'. This derivative crystallizes with 1.5 mols of water which is lost on drying at 65° *in vacuo*.

Dehydrogenation of torreyol with selenium gives cadalene.

When heated with formic acid, torreyol yields torreyene C₁₅H₂₄, b₁ 89°–90°, [α]_D +46° 40', d₄²⁵ 0.9206, n_D²⁵ 1.50591.

Torreyene resembles cadinene.

Use.—Torreyol is not used in our industries.

¹ *J. Soc. Chem. Ind. Japan* **43**, *Suppl. Bind.* (1940), 64; **44**, *Suppl. Bind.* (1941), 119. *Chem. Abstracts* **34** (1940), 6936; **38** (1944), 4262.

² *Ibid.*

Cadinol

 $C_{15}H_{26}O$

Mol. Weight 222.36

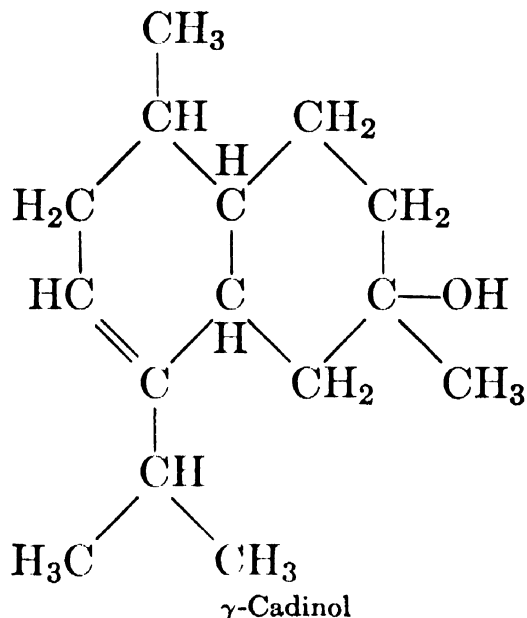
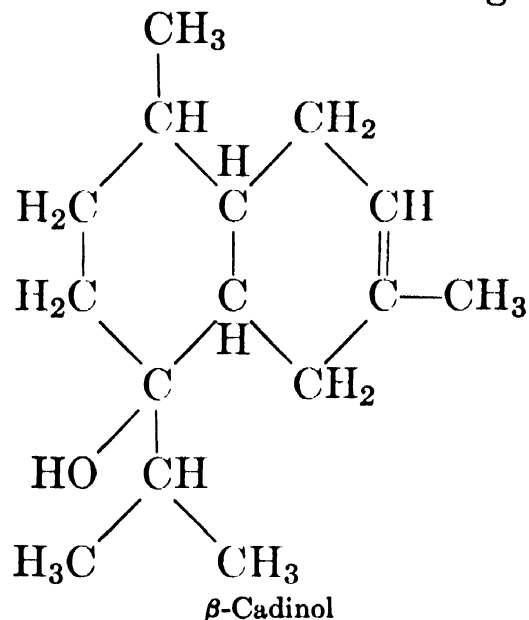
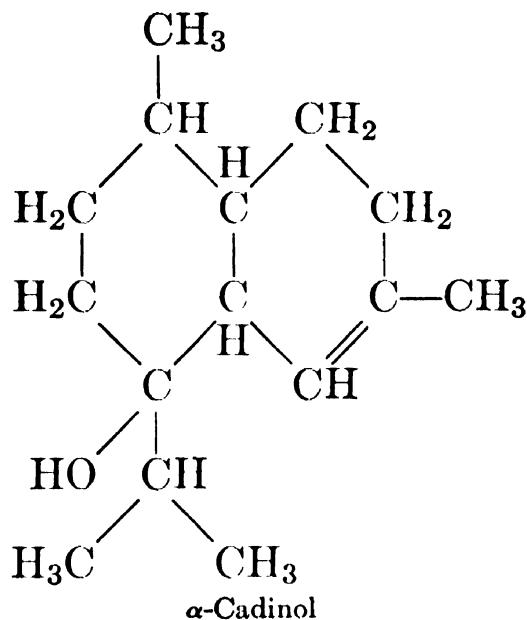

From the experimental evidence gathered to date it seems probable that cadinol may be represented by one or all of the three isomeric bicyclic terpene alcohol formulas represented above and that in nature it occurs more often as a mixture.

Occurrence.—*d*-Cadinols primarily have been isolated from galbanum oil, Formosa *Pinus pentaphylla* (Sebe¹), the leaf oil of *Chamaecyparis obtusa formosana*, Hayata or Arisan-Hinoki (Kafuku and Nozoe²), and West Indian sandalwood oil (Ruzicka, Capato and Huyser,³ and Deussen⁴).

l-Cadinols are predominant in the alcohols occurring in cubeb oil, in the volatile and empyreumatic oil of cade (*Juniperus oxycedrus*), in Java citronella oil, and in oil of *Cedrela toona* Roxb.

Isolation.—By fractional distillation in vacuo—for instance, of galbanum or cubeb oil.

Identification.—Cadinol can be characterized by the preparation of cadinene dihydrochloride m. 118°–119° (see “Cadinene”). Dehydrogenation of cadinol gives cadalene which yields a definitive picrate m. 115°, and a styphnate m. 139°.

Properties.—Cadinol is a colorless oil having these properties:

d-Cadinol from galbanum oil and composed of α -, β - and γ - isomers with the α - and β - forms in predominance (Ruzicka and Stoll ⁵):

b_{12}	155°–156°	α_D	+7° 42'
d_4^{14}	0.9665	n_D^{14}	1.5054

A product isolated from *Pinus pentaphylla* by Sebe ⁶ and described as predominantly a γ - isomer had the following properties:

m.	135.5°
b_8	162.5°
$[\alpha]_D^{20}$	+99° 30'

l-Cadinol derived from cubeb oil by Henderson and Robertson,⁷ and from oil of juniper by Mousseron, Granger and Ronayroux:⁸

b_{20}	166° ⁸	$[\alpha]_{5461}^{15}$	–54° 0' ⁷
b_{10}	153°–155° ⁷	$[\alpha]_{5460}$	–64° 56' ⁸
d_{25}	0.9700 ⁸	$[\alpha]_{579}$	–56° 53' ⁸
d_{20}	0.9727 ⁷	n_D^{25}	1.50741 ⁸
		n_D^{20}	1.508 ⁷

These latter authors, in their study of the *l*- isomer isolated from *Juniperus oxycedrus* L., prepared the dihydro derivative and recorded its properties as:

b_{20}	155°	$[\alpha]_{5790}$	–29° 32'
d_{25}	0.9563	$[\alpha]_{5460}$	–33° 28'
		n_D^{25}	1.49680

A laevo cadinol of uncertain structure has been recently isolated from Java citronella oil by Plattner and Markus.⁹ It may be related either to the product of Sebe ¹⁰ or to the solid cadinol of Nisida and Uota ¹¹ isolated from *Torreya nucifera* which they considered to be a 1,6-dimethyl-4-isopropylidene-6-hydroxynaphthalene and named torreyol. Plattner and Markus found for this cadinol:

m.	72.5°
$[\alpha]_D$	–39° 24' (c = 1.32 in CHCl ₃)

and further that it yielded a dihydro derivative C₁₅H₂₈O with m. 124.5°, $[\alpha]_D$ –72° 30'.

Being a tertiary alcohol, cadinol does not react with phthalic anhydride at 110°.

Use.—Cadinol, as such, is not used in our industries.

- ¹ *J. Chem. Soc. Japan* **61** (1940), 1269. *Chem. Abstracts* **37** (1943), 4064.
² *Bull. Chem. Soc. Japan* **6** (1931), 118. *Chem. News* **143** (1931), 21. *Chem. Zentr.* I (1932), 84.
³ *Rec. trav. chim.* **47** (1928), 370.
⁴ *J. prakt. Chem.* II, **120** (1929), 123.
⁵ *Helv. Chim. Acta* **7** (1923), 94.
⁶ *J. Chem. Soc. Japan* **61** (1940), 1269. *Chem. Abstracts* **37** (1943), 4064.
⁷ *J. Chem. Soc.* (1926), 2811.
⁸ *Compt. rend.* **208** (1939), 1411.
⁹ *Helv. Chim. Acta* **25** (1942), 1674.
¹⁰ *J. Chem. Soc. Japan* **61** (1940), 1269.
¹¹ *J. Soc. Chem. Ind. Japan* **43** (1940) Suppl. Binding, 64 (1940) in German. *Chem. Abstracts* **34** (1940), 6936.

Guaiol

C₁₅H₂₆O

Mol. Weight 222.36

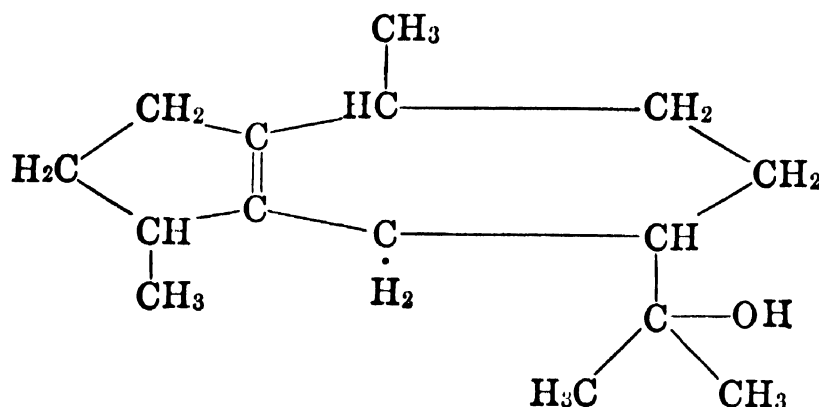

The constitution of this apparently bicyclic tertiary sesquiterpene alcohol has been the subject of many investigations but final confirmation of the structural formula was achieved by Plattner and Magyar.¹

Occurrence.—Schimmel & Co.² first isolated guaiol from guaiac wood oil (*Bulnesia sarmienti* Lor.). The alcohol seems to occur also in a few other essential oils.

Isolation.—By fractional distillation and fractionation of the high boiling portions of guaiac wood oil.

Identification.—Through its properties and by the dinitrobenzoate m. 137°–137.5° (corr.), according to Plattner and Lamay.³

Properties.—Guaiol is a solid mass crystallizing in prisms m. 91°–93° (Semmler and Mayer,⁴ Eyken,⁵ Ruzicka, Pontalti and Balas,⁶ Ruzicka and Haagen-Smit,⁷ and Gildemeister and Hoffmann⁸). It possesses a faint but lasting odor. The following properties have been reported by Gadamer and Amenomiya,⁹ Wallach and Tuttle,¹⁰ Semmler and Mayer,¹¹ and Gildemeister and Hoffmann:¹²

b.	288° ¹⁰	$[\alpha]_D^{20}$	–29° 48' (in alcohol) ⁹
b ₉	147°–149° ¹¹	n_D^{100}	1.4716 ¹¹
d ₂₀ ¹⁰⁰	0.9074 ¹¹	n_D^{20}	1.5100 ^{11,12}
d ₄ ²⁰	0.9714 ^{11,12}	Mol. refr.	68.35 ^{11,12}

When dehydrating guaiol with potassium hydrogen sulfate, Gadamer and Amenomiya¹³ obtained guaiene C₁₅H₂₄, a bicyclic sesquiterpene with these properties:

b ₉	123°–124°	[α] _D ²⁰	–40° 21'
d ₄ ²⁰	0.9085	n _D ²⁰	1.50049

Mol. refr. 66.2

Ruzicka, Pontalti and Balas¹⁴ reported for guaiene which they obtained by digesting guaiol for a short time with formic acid:

b ₁₂	128°–130°	α _D	–16° 48'
d ₄ ¹⁹	0.9115	n _D ¹⁹	1.5022

On dehydrogenation with sulfur, guaiene yields the deep blue guaiazulene C₁₅H₁₈, b₁₁ 164°, d₄¹⁸ 0.9759. This hydrocarbon is related to azulene and can be characterized by the preparation of a picrate m. 122°, and of a styphnate m. 105°–106° (cf. "Guaiazulene").

The tertiary character of the hydroxyl group in guaiol is indicated by the fact that guaiol does not react with phthalic anhydride at 130°, and that it cannot readily be acetylated. Furthermore, guaiol yields a stable chromate, according to Scholz.¹⁵

Use.—Guaiol, as such, has not found any noteworthy use in our industries.

¹ *Helv. Chim. Acta* **24** (1941), 191; **25** (1942), 581.

² *Ber. Schimmel & Co.*, April (1892), 42; April (1893), 33.

³ *Helv. Chim. Acta* **23** (1940), 902.

⁴ *Ber.* **45** (1912), 1391.

⁵ *Rec. trav. chim.* **25** (1906), 40.

⁶ *Helv. Chim. Acta* **6** (1923), 862.

⁷ *Ibid.* **14** (1931), 1126.

⁸ "Die Ätherischen Öle," 3d Ed., Vol. I, 494.

⁹ *Arch. Pharm.* **241** (1903), 43.

¹⁰ *Liebigs Ann.* **279** (1894), 395.

¹¹ *Ber.* **45** (1912), 1391.

¹² "Die Ätherischen Öle," 3d Ed., Vol. I, 494.

¹³ *Arch. Pharm.* **241** (1903), 43.

¹⁴ *Helv. Chim. Acta* **6** (1923), 861.

¹⁵ *Inaugural Dissertation, University Leipzig* (1930). Cf. *Ber. Schimmel & Co.* (1931), 174.

See Wienhaus, *Ber.* **47** (1914), 330.

"Calameone"

C₁₅H₂₆O₂

Mol. Weight 238.36

This compound has been investigated in the past by Schimmel & Co.,¹ by von Soden and Rojahn,² and by Thoms and Beckstroem,³ but its constitution was not established. However, advances have been made more recently. Simonsen⁴ offered the opinion that the designation "calameone" is ill chosen, as there exists no evidence that this substance is a ketone. This

view finds ample support in the recent work of Böhme ⁵ who described this compound as an unsaturated bicyclic sesquiterpene alcohol containing two hydroxy groups and belonging to the cadalene series.

Occurrence.—In the high boiling fractions of calamus root oil.

Isolation.—By fractional distillation, according to Thoms and Beckstroem.⁶ Böhme ⁷ found that the product sublimes in a high vacuum (.006 mm.) at 65°–75°.

Identification.—On treatment with hydrogen chloride, “calameone” yields an addition compound $C_{15}H_{26}O_2 \cdot HCl$; m. 119°.

Benzoate m. 155°.

Böhme prepared the “dihydrocalameone” m. 133°.

Properties.—“Calameone” melts at 168° (Thoms and Beckstroem), 169° (Böhme); $[\alpha]_D^{26} -8^\circ 58'$ (in 5% alcoholic solution).

On oxidation with potassium permanganate, “calameone” yields calameonic acid $C_{15}H_{24}O_4 \cdot 2H_2O$; m. 153°.

Böhme found that the corresponding hydrocarbon calamene ($C_{15}H_{22}$), b_{12} 137°–139°, when heated with sulfur for 6 hr., yielded cadalene.

Use.—“Calameone” is not used in our industry.

¹ *Ber. Schimmel & Co.*, Oct. (1899), 8.

² *Pharm. Ztg.* **46** (1901), 243.

³ *Ber.* **34** (1901), 1021; **35** (1902), 3187. *Ber.* **35** (1902), 3195.

⁴ “The Terpenes,” Vol. II (1932), 588.

⁵ *Arch. Pharm.* **278** (1940), 1.

⁶ *Ber.* **34** (1901), 1021; **35** (1902), 3187. *Ber.* **35** (1902), 3195.

⁷ *Arch. Pharm.* **278** (1940), 1.

(d) TRICYCLIC SESQUITERPENE ALCOHOLS.

Ledol

(Ledum Camphor)

$C_{15}H_{26}O$

Mol. Weight 222.36

The constitution of this tricyclic tertiary sesquiterpene alcohol was investigated by Hjelt and Collan,¹ Rizza,² Semmler and Mayer,³ Wienhaus,⁴ Komppa,⁵ and Komppa and Nyman.⁶ Since ledol is an alcohol, the old designation ledum camphor should be abandoned. Komppa and Nyman ⁷ suggested the following structural formula for ledol:

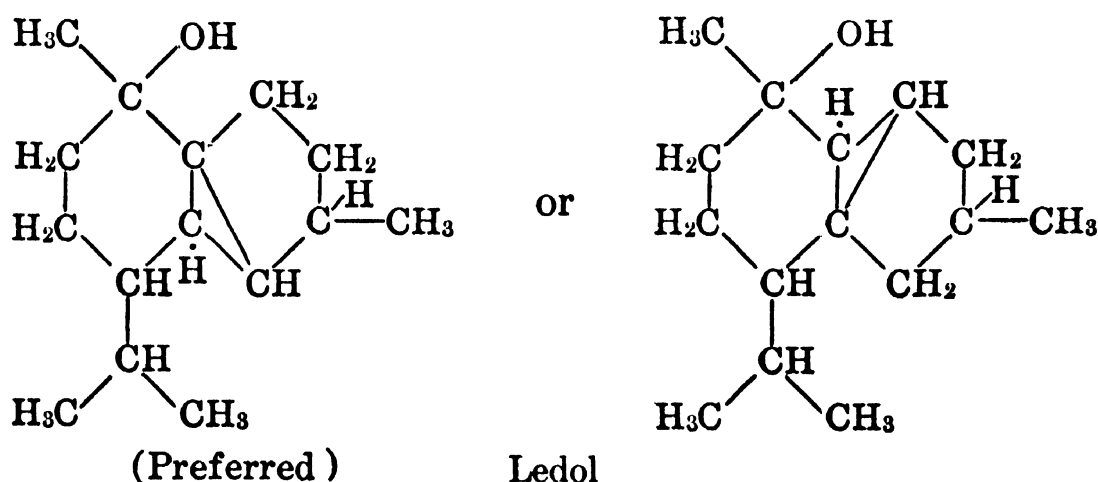

Occurrence.—In marsh tea oil, distilled from the leaves and flowering tops of *Ledum palustre* L., *groenlandicum* and *columbianum*. Observed by Hasenfratz ⁸ in the leaves of *Sphacele parviflora* L. from Colombia.

Isolation.—By fractional distillation and fractionation of the high boiling parts of marsh tea oil.

Identification.—Through its properties. Wienhaus ⁹ prepared a crystalline chromate $(C_{15}H_{25})_2 \cdot CrO_4$, m. 92° , $[\alpha]_{(Li\ red)} +30^\circ 0'$.

Properties.—Ledol crystallizes in colorless needles m. 104° – 105° , which readily sublime below their melting point.

The following properties have been reported by the above-mentioned authors:

m.	105° ⁵	$[\alpha]_D$	$+7^\circ 59'$ ¹
b.	292° (corr.) ²	n_D^{110}	1.4667 ³
d_{20}^{100}	0.9094 ³		
d_{20}	0.9814 ⁵		

Ledol is very resistant to oxidation by potassium permanganate. Otherwise ledol is somewhat unstable and readily loses water, yielding on treatment with potassium bisulfate a sesquiterpene $C_{15}H_{24}$, viz., ledene, b_{752} 264° , b_6 115° – 118° , d_{20} 0.9233, d_{19} 0.9237, n_D^{20} 1.50273. When dehydrogenated with selenium, ledol and ledene yield azulene and some cadalene. Dehydrogenating ledol with selenium or sulfur, Nyman and Mikander ¹⁰ obtained two different azulenes, viz., Se-ledum azulene and s-ledum azulene, both of which form characteristic molecular addition compounds with trinitrobenzene: Se adduct m. 146° – 147° , S adduct m. 152° – 153.5° .

Use.—Ledol is not used in our industries.

¹ *Ber.* **15** (1882), 2500. See also Hjelt, *Ber.* **28** (1895), 3087.

² *J. Russ. Phys. Chem. Soc.* **15** (1883), 362; **19** (1887), 324. *Ber.* **16** (1883), 2311.

³ *Ber.* **45** (1912), 1391.

⁴ *Ber.* **47** (1914), 330.

⁵ *Z. angew. Chem.* **45** (1932), 588. *Kgl. Norske Videnskab. Selskabs Skrifter*, No. 1 (1933). *Chem. Abstracts* **28** (1934), 4724.

⁶ *Compt. rend. trav. lab. Carlsberg Ser. chim.* **22** (1938), 272. *Chem. Abstracts* **32** (1938), 6234.

⁷ *Ibid.*

⁸ *Compt. rend.* **187** (1928), 903.

⁹ *Ber.* **47** (1914), 330.

¹⁰ *Suomen Kemistilehti* **14B** (1941), 3. *Chem. Abstracts* **35** (1941), 4755.

(e) SESQUITERPENE ALCOHOLS OF DOUBTFUL CONSTITUTION.

Vetivenols

(Vetiverols)

$C_{15}H_{24}O$

Mol. Weight 220.34

The sesquiterpene alcohols contained in oil of vetiver have been investigated by several workers, among them Ruzicka, Capato and Huyser,¹ Pfau

and Plattner,² and Sabetay and Trabaud,³ but the chemical constitution of these alcohols has not yet been fully established.

At least 60 per cent of the sesquiterpene alcohols present in Java vetiver oil seem to consist of a mixture of **primary** alcohols $C_{15}H_{24}O$. This mixture of primary alcohols was obtained by heating the sesquiterpene alcohol fraction with phthalic anhydride to 90° , and then by separating and hydrolyzing the resulting acid phthalates. A tricyclic alcohol b_{12} 170° – 172° , d_4^{18} 1.0228, $\alpha_D +29^\circ 36'$, n_D^{18} 1.5255, largely predominates, whereas the distillate recognized as bicyclic alcohols b_{12} 152° – 154° , d_4^{17} 0.9851, n_D^{17} 1.5241, amounts to only about 10 per cent of the mixture of primary alcohols. On dehydrogenation, the bicyclic alcohols yielded eudalene and cadalene. An esterified primary tricyclic alcohol was also described by Ruzicka, Capato and Huyser,⁴ b_{12} 160° – 162° , d_4^{15} 1.0186, n_D^{15} 1.5251.

The **tertiary** sesquiterpene alcohols which do not react with phthalic anhydride likewise seem to be a mixture. On warming with formic acid, only a part of these alcohols could be dehydrated to bicyclic sesquiterpenes. On dehydrogenation, these sesquiterpenes gave cadalene. The tertiary sesquiterpene alcohols amount to about one-third of the total sesquiterpene alcohol fraction of vetiver oil. They seem to contain one representative of the hydrated naphthalene derivatives belonging to the cadinene type.

The tertiary alcohol unaltered by phthalic anhydride and obtained fairly pure was bicyclic, b_{12} 150° – 155° , d_4^{10} 0.9910, n_D^{10} 1.5185.

Réunion oil contained somewhat similar $C_{15}H_{24}O$ fractions. A primary bicyclic alcohol was isolated b_{12} 150° – 160° , d_4^{19} 0.9805, n_D^{19} 1.5242, which yielded eudalene with sulfur, and a tricyclic tertiary vetiverol b_{12} 165° – 170° , d_4^{17} 1.0182 was also observed in the oil.

Oxidizing vetiverol (free from vetiverone) with potassium chromate and sulfuric acid, Sabetay and Trabaud⁵ obtained crude vetiveral b_{10} 138° – 145° , d_{15} 1.003, $\alpha_D +40^\circ 33'$, n_D^{20} 1.5132, containing 64.1 per cent of vetiveral $C_{15}H_{22}O$. Vetiveral is said to possess an incense-like odor.

Use.—The vetivenols or vetiverols and their acetates are used quite widely in the compounding of high-grade perfumes, especially of oriental character. The odor of these alcohols is pleasant, mild and lasting, whereas the acetates possess a somewhat dry character.

¹ *Rec. trav. chim.* **47** (1928), 370.

² *Helv. Chim. Acta* **22** (1939), 640.

³ *Bull. soc. chim.* [5], **6** (1939), 740.

⁴ *Rec. trav. chim.* **47** (1928), 370.

⁵ *Bull. soc. chim.* [5], **6** (1939), 740.

Calamemenol

$C_{15}H_{24}O$

Mol. Weight 220.34

This sesquiterpene alcohol was investigated by Semmler and Spornitz,¹ and by Ruzicka, Meyer and Mingazzini,² but its constitution has not been

elucidated. In fact, it remains doubtful whether this alcohol has ever been obtained in pure form and free from asarone, another constituent of calamus oil.

Occurrence.—In the oil distilled from the rhizomes of *Acorus calamus* L.

Isolation.—By repeated fractionation of calamus root oil.

Identification.—Calamenenol does not yield any crystalline derivatives; therefore it has to be characterized through its properties.

Properties.—The following properties have been reported for calamenenol by the above-named investigators:

b_{13}	$160^{\circ}-165^{\circ}$ ²
d_{28}	0.96115 ¹
n_D	1.5098 ¹

Calamenenol is somewhat unstable and readily loses water with formation of calamenene $C_{15}H_{22}$, a hydrocarbon possessing these properties:

b_{15}	$136^{\circ}-143^{\circ}$ ¹	α_D	$+6^{\circ} 0'$ ¹
d_{19}^{20}	0.9324 ¹	n_D	1.52317 ¹

On dehydrogenation with sulfur, calamenenol yields cadalene.

Use.—Calamenenol is not used in our industries.

¹ *Ber.* **46** (1913), 3704.

² *Helv. Chim. Acta* **5** (1922), 358.

Cedrenol

$C_{15}H_{24}O$

Mol. Weight 220.34

The constitution of cedrenol, a primary sesquiterpene alcohol, is dependent upon that of the hydrocarbon, cedrene, since it has been shown by various investigators that, on oxidation of cedrene, cedrenol is formed (see "Cedrene").

Occurrence.—Found in the higher boiling fractions of American cedarwood oil by Semmler and Mayer.¹

Isolation.—By fractional distillation, treatment of the fraction with phthalic anhydride in benzene solution, and hydrolysis, cedrenol is obtained. For further purification Semmler and Mayer suggested the conversion into cedrenol acetate; on hydrolysis of the acetate with alkali, cedrenol is formed.

Identification.—Cedrenol can be identified by its physical properties and by the following methods:

Dehydration is readily effected, according to Ruzicka, Plattner and Kusserow,² by acetic anhydride to obtain a hydrocarbon, cedrenene, with these properties: b_{11} 122° , d_4^{20} 0.9432, α_D $+138^{\circ} 0'$, n_D^{20} 1.5202. This unsaturated compound smoothly undergoes a diene reaction with dimethyl ester of acetylene dicarboxylic acid to form an adduct: $C_{21}H_{28}O_4$, m. $132^{\circ}-132.5^{\circ}$, which is hydrolyzed to a characteristic free acid $C_{19}H_{24}O_4$, m. 230° .

On bromination under carbon dioxide, cedrene yields almost quantitatively cedrene dibromide m. 93°–95°.

Several oxidative degradation products may also be used in connection with other reactions of cedrene, for purposes of diagnosis.

Properties.—The following properties were reported by Ruzicka, Plattner and Kusserow,³ Blumann, Hellriegel and Schulz,⁴ and Semmler and Mayer:⁵

m.	103.5°–104° ³ (crystallized from petroleum ether)	d_{20}	1.0083 ⁵
	103°–104° ⁴	α_D^{20}	$\pm 0^\circ$ ⁵
$b_{9.5}$	166°–169° ⁵	n_D^{20}	1.5212 ⁵

Use.—Due to their high fixation value cedrenol-containing fractions of cedarwood oil are used for the scenting of soaps and all kinds of technical preparations.

¹ *Ber.* **45** (1912), 786.

² *Helv. Chim. Acta* **25** (1942), 85.

³ *Ibid.*

⁴ *Ber.* **62** (1929), 1697; **64** (1931), 1541.

⁵ *Ber.* **45** (1912), 786.

Cedrol

(Cedar Camphor or Cypress Camphor)

$C_{15}H_{26}O$

Mol. Weight 222.36

The constitution of cedrol, a tertiary sesquiterpene alcohol, is related to that of the hydrocarbon, cedrene, since it has been shown by various investigators that, on dehydration, cedrol yields cedrene (see "Cedrene").

Occurrence.—Cedrol has been found in oil of *Juniperus virginiana* L. by Chapman and Burgess;¹ in oil of cypress (*Cupressus sempervirens* L.) and *Juniperus procera* Hochst. by Schimmel & Co.;² in *Juniperus polycarpos* Koch by Rutovski, Gusseva and Koroleva;³ in *Juniperus chinensis* L. by Kondo,⁴ and So Uchida;⁵ in *Juniperus excelsa* M.B. = *J. sabina* L. var. *taurica* Tall. by Rutovski and Vinogradova,⁶ in *Cunninghamia konishi* Hayata by Ikeda and Fujita;⁷ and in Smyrna origanum oil.⁸

It is possible that some of the oils, such as *Juniperus chinensis* or Smyrna origanum had been adulterated with a fraction of cedarwood oil from which the cedrol or cedrene content originated.

Isolation.—By fractional distillation, then freezing out and recrystallization from methanol and petroleum ether.

Rabak⁹ suggested a method based on the insolubility of cedrol in cold dilute alcohol:

"One hundred parts of oil are agitated vigorously with 6 parts of 65 per cent alcohol for one to two minutes. Sudden and complete solidification of the emulsion thus formed usually results, if the oil contains a sufficient quantity of cedrol. If

not, solidification may be accomplished by adding a small quantity of crystalline cedrol to the emulsion, then placing it in a refrigerator for several hours. The solidified mass is placed upon a force filter, the fine silky crystals are washed with a few drops of cold 98 per cent alcohol, and the dry crystals weighed. The cedrol may be purified by dissolving it in hot alcohol, then cooling and filtering the mass."

This method is suggested for the quantitative determination of cedrol, but the results give only comparative values.

Identification.—Cedrol can be characterized by its derivatives and by its dehydration product, viz., cedrene:

Cedrol phenylurethane m. 106°–107° (crystallized from dilute alcohol), according to Schimmel & Co.¹⁰

Cedrol chromate (crystallized from petroleum ether) m. 115°, as described by Wienhaus,¹¹ results from the action of chromic acid on cedrol in carbon tetrachloride solution.

Being a tertiary alcohol, cedrol is very easily dehydrated by the action of formic acid, phosphorus pentoxide, zinc chloride, and other dehydration agents. The resulting cedrene can then be identified as such.

Properties.—Cedrol forms white crystals, the odor of which is persistent, pleasing and suggestive of cedarwood.

Cedrols separated from various oils show a marked variation in their optical rotatory power, but it is usually dextrorotatory.

The following properties have been reported by Naves and co-workers,¹² Schimmel & Co.,^{13,14,15} Rabak,¹⁶ and observed by Fritzsche Brothers, Inc.:¹⁷

m.	(from <i>Juniperus procera</i> Hochst.)	86°–86.5° ¹²
	(from oil of cypress)	86°–87° ^{13,16}
	(from oil <i>Smyrna origanum</i>)	85.5°–87° ¹⁴
	(from oil cedarwood— <i>Juniperus virginiana</i>)	86.6°–87° ¹⁷
b.	(from oil of cypress)	290°–292° ¹³
b ₅	(from oil of cypress)	135° ¹³
α _D	(from oil of cypress)	inactive ¹³
	(from oil of cedarwood)	$\left\{ \begin{array}{l} +0^{\circ} 56' 17 \text{ (c = 10 in chloroform)} \\ +9^{\circ} 31' 13 \text{ (c = 11.2 in chloroform)} \\ +10^{\circ} 30' 15 \text{ (c = 10 in chloroform)} \\ +8^{\circ} 48' 14 \text{ (c = 10 in chloroform)} \end{array} \right.$

Naves and co-workers¹⁸ (from oil of *Juniperus procera*):

[α] _D ¹⁸	+13° 4' (c = 5.5 in absolute alcohol)
	+8° 46' (c = 10 in benzyl alcohol)
	+14° 16' (c = 10 in dioxane)

According to So Uchida¹⁹ cedrol from *Juniperus chinensis* L. (Byakushin) has an optical rotation as high as α_D +85° 23'.

Use.—Due to its high boiling point and faint, pleasant odor, cedrol is used mainly as a fixative in perfumes, cosmetics, and soaps.

- ¹ *Proc. Chem. Soc.* (1896), 140.
- ² *Ber. Schimmel & Co.* I (1910), 36; II (1904), 20; II (1911), 105.
- ³ *Riechstoff Ind.* **8** (1933), 161.
- ⁴ *J. Pharm. Soc. Japan* (1907), 236. *Ber. Schimmel & Co.*, Oct. (1907), 41.
- ⁵ *Ber. Schimmel & Co.* (1929), 52.
- ⁶ *Trans. Sci. Chem. Pharm. Inst. Moscow* **17** (1927), 146.
- ⁷ *J. Chem. Soc. Japan* **50** (1929), 32. *Chem. Abstracts* **25** (1931), 5506.
- ⁸ *Ber. Schimmel & Co.* Oct. (1906), 72.
- ⁹ *Am. Perfumer* **23** (1929), 727.
- ¹⁰ *Ber. Schimmel & Co.* II (1906), 72; I (1910), 36.
- ¹¹ *Ber.* **47** (1914), 330.
- ¹² *Helv. Chim. Acta* **26** (1943), 314.
- ¹³ *Ber. Schimmel & Co.* II (1904), 19.
- ¹⁴ *Ibid.* II (1906), 72.
- ¹⁵ *Ibid.* I (1910), 36.
- ¹⁶ *Am. Perfumer* **23** (1929), 727.
- ¹⁷ Laboratory report.
- ¹⁸ *Helv. Chim. Acta* **26** (1943), 314.
- ¹⁹ *Ber. Schimmel & Co.* (1929), 52.

Globulol

$C_{15}H_{26}O$

Mol. Weight 222.36

The constitution of this sesquiterpene alcohol remains obscure, except for the fact that, according to Ruzicka, Pontalti, and Balas,¹ it is a derivative of cadalene. This holds true also of the sesquiterpenes occurring in oil of *Eucalyptus globulus*.

Occurrence.—Schimmel & Co.² found globulol in oil of *E. globulus*.

Isolation.—The last runs in the fractionation of oil of *E. globulus* separate crystals on standing. After drying on porous clay plates, they are recrystallized from 70% alcohol.

Identification.—According to Scholz,³ globulol forms a stable chromate.

Properties.—Globulol crystallizes in the form of shiny, almost odorless needles:

m.	88.5°
b ₇₅₅	283°
[α] _D	−35° 29' (in 12% chloroform solution)

On dehydration globulol yields two different sesquiterpenes.

Use.—Globulol, as such, is not used in our industries.

¹ *Helv. Chim. Acta* **6** (1923), 861.

² *Ber. Schimmel & Co.*, April (1904), 45. See also Semmler and Tobias, *Ber.* **46** (1913), 2026.

³ Inaugural Dissertation, Univ. Leipzig, 1930. *Ber. Schimmel & Co.* (1931), 174.

Cubebol

C₁₅H₂₆O

Mol. Weight 222.36

The constitution of this sesquiterpene alcohol has not been elucidated. According to Henderson and Robertson,¹ "cubeb camphor" as described in the early literature has not been found to be identical with their cubebol.

Occurrence.—The authors cited in the foregoing paragraph first isolated this terpenic alcohol from the higher boiling fractions of oil of false cubeb and named it "cubebol."

Isolation.—Separated from the higher boiling fractions (b₁₀ 153°–155°) of hydrolyzed false cubeb oil, the alcohol is obtained in pure form by hydrolysis of its phenylurethane derivative (yield ∼ 4%).

Identification.—Cubebol can be characterized by the preparation of several derivatives:

- (1) α-naphthylurethane m. 197°–198.5°
- (2) phenylurethane m. 186°, [α]_D¹⁹₅₄₆₁ +58° 54' (in 5% chloroform)

The dibromide of the phenylurethane melts at 76°–80°.

Properties.—Cubebol melts at 61°–62°. When treated with hydrogen chloride, cubebol does not yield cadinene dihydrochloride.

Use.—Isolated cubebol, as such, is not used in our industries.

¹ *J. Chem. Soc.* (1926), 2811.

Patchouly Alcohol

(Patchouly Camphor)

C₁₅H₂₆O

Mol. Weight 222.36

The constitution of this apparently tricyclic tertiary, sesquiterpene alcohol has not been established, despite several investigations by Wallach,¹ Gadamer and Amenomiya,² and Semmler and Mayer.³

Occurrence.—In oil of patchouly.

Isolation.—By fractional distillation of the high boiling portions of patchouly oil.

Identification.—Through its properties.

Wienhaus⁴ prepared a stable chromate of patchouly alcohol. According to Scholz⁵ this chromate crystallizes in the form of shiny, carmine red leaflets m. 117°–118° (with decomposition).

Properties.—Patchouly alcohol separates in the form of odorless crystals m. 56°, according to the authors listed above. The following properties have been reported by Semmler and Mayer⁶ and Schimmel & Co.:⁷

b ₈	∼ 140° ⁷	[α] _D	−97° 42' (in chloroform) ⁷
d ₂₀ ⁶⁵	0.9924 ⁶	n _D ⁶⁵	1.5029 ⁶
d ₄ ²⁰	1.0284 ⁶	n _D ²⁰	1.5245 ⁶

Patchouly alcohol cannot be acetylated quantitatively by the usual method.

On distillation at atmospheric pressure, or on treatment with dehydrating agents, patchouly alcohol readily loses water, yielding thereby patchoulene, a sesquiterpene with these properties (cf. Schimmel & Co.,⁸ and Gadamer and Amenomiya⁹):

b.	255°–256° ⁸	d_4^{20}	0.9296 ⁹
$b_{12-12.5}$	112°–115° ⁹	$[\alpha]_D^{20}$	–38° 5' ⁹
		n_D^{20}	1.49835 ⁹

No crystalline derivatives of patchoulene are known.

Use.—Patchouly alcohol, as such, is not used in our industries.

¹ *Liebigs Ann.* **271** (1892), 299; **279** (1894), 394.

² *Arch. Pharm.* **241** (1903), 22.

³ *Ber.* **45** (1912), 1391.

⁴ *Ber.* **47** (1914), 330.

⁵ Inaugural Dissertation, Univ. Leipzig (1930). *Ber. Schimmel & Co.* (1931), 173.

⁶ *Ber.* **45** (1912), 1391.

⁷ *Ber. Schimmel & Co.*, April (1904), 74.

⁸ *Ibid.*, 75.

⁹ *Arch. Pharm.* **241** (1903), 41.

Kessyl Alcohol

$C_{15}H_{26}O$

Mol. Weight 222.36

From the data collected mainly by Asahina and co-workers, it may be concluded that kessyl alcohol is a saturated tricyclic secondary sesquiterpene alcohol. One of the rings contains oxygen as ring member. On dehydrogenation this oxygen bridge is opened with resulting formation of kessazulene, which is identical with guaiazulene (Asahina et al.,¹ and Ruzicka and Haagen-Smit²). Kessyl alcohol, therefore, possesses a carbon skeleton closely allied to that of guaiol. It is distinguished from this sesquiterpene alcohol by the absence of a double bond, the presence of an oxide ring (Asahina and Hongo³), and a secondary instead of a tertiary hydroxyl group (Asahina and Nakanishi⁴). The positions of the different groups have not been established and it remains uncertain whether there exists a direct chemical relation between kesso glycol and kessyl alcohol.

Occurrence.—The acetate of kessyl alcohol occurs in kesso oil derived from the roots of *Valeriana officinalis* L. var. *angustifolia* Miq., which plant in Japan is called Kesso kano-koso. Japanese workers reported the acetate also in *Valeriana officinalis* L. var. *latifolia* Miq. In a variety grown at Toyana Pharmaceutical College, kessyl alcohol or acetate was practically absent, but the oil contained kesso glycol diacetate which, on hydrolysis, gave kesso glycol and acetic acid (Asahina and Nakanishi,⁵ and Kaneoka and Tutida⁶).

Identification.—Kessyl alcohol can be characterized by the determination of its physicochemical properties and by the preparation of the urethane which, according to Asahina and Hongo,⁷ melts at 168°.

Properties.—The same authors,⁸ Bertram and Gildemeister,⁹ and Gildemeister and Hoffmann,¹⁰ reported these properties of kessyl alcohol:

m.	85° ^{9,10}	b ₁₁	155°–156° ^{9,10}
b.	300°–302° ^{9,10}	[α] _D ²³	–44° 43' ⁸

Kessyl acetate contains 1 mol of crystallization water (C₁₇H₂₈O₃ + 1H₂O). Bertram and Gildemeister,¹¹ Gildemeister and Hoffmann,¹² and Asahina and Nakanishi¹³ reported the following properties:

m.	60°–61° ¹³	[α] _D	–70° 6' ^{11,12}
b ₇₅₄	280°–283° ¹³	[α] _D ¹⁸	–62° 44' (–65° 6' for the anhy-
b _{15–16}	178°–179° ^{11,12}		drous compound) ¹³
b _{4.5}	148°–150° ¹³		

Kesso glycol, C₁₅H₂₆O₃, has been described by Asahina and Nakanishi,¹⁴ and by Kaneoka and Tutida:¹⁵

m.	58°–59° ^{14(?)}
	128° ¹⁵
[α] _D ²³	–24° 23' ¹⁵

Kesso glycol can be characterized by the preparation of its dibenzoate m. 179°, [α]_D²⁰ –48° 5'.

The same authors reported for *kesso glycol diacetate* C₁₉H₃₀O₅:

m.	119° ¹⁴	[α] _D ²³	–68° 53' (in alcohol) ¹⁵
b ₇₅₀	259° ¹⁴	[α] _D ¹⁸	–58° 9' ¹⁴

Use.—Kessyl alcohol, as such, is not used in our industries.

¹ *J. Pharm. Soc. Japan* **52** (1932), 1. *Chem. Abstracts* **26** (1932), 2972.

² *Helv. Chim. Acta* **14** (1930), 1122.

³ *J. Pharm. Soc. Japan* No. 506 (1924) 227. *Chem. Abstracts* **18** (1924), 2510.

⁴ *J. Pharm. Soc. Japan* No. 536 (1926), 823. *Chem. Abstracts* **21** (1927), 2263.

⁵ *J. Pharm. Soc. Japan* **49** (1929), 135. *Chem. Abstracts* **23** (1929), 3455.

⁶ *J. Pharm. Soc. Japan* **61** (1941), 6. *Chem. Abstracts* **35** (1941), 4773.

⁷ *J. Pharm. Soc. Japan* No. 506 (1924), 227. *Chem. Abstracts* **18** (1924), 2510.

⁸ *Ibid.*

⁹ *Arch. Pharm.* **228** (1890), 488.

¹⁰ "Die Ätherischen Öle," 3d Ed., Vol. III, 942.

¹¹ *Arch. Pharm.* **228** (1890), 490.

¹² "Die Ätherischen Öle," 3d Ed., Vol. III, 942.

¹³ *J. Pharm. Soc. Japan* **49** (1929), 135. *Chem. Abstracts* **23** (1929), 3455.

¹⁴ *Ibid.*

¹⁵ *J. Pharm. Soc. Japan* **61** (1941), 6. *Chem. Abstracts* **35** (1941), 4773.

D. AROMATIC ALCOHOLS

Some aromatic alcohols are important constituents of essential oils.

Benzyl Alcohol
 C_7H_8O Mol. Weight 108.13
 Phenylcarbinol

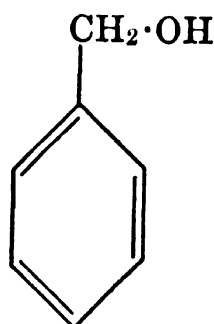

Occurrence.—Benzyl alcohol occurs free in oil of ylang ylang, in acacia and tuberose flower oils, etc. As acetate in oil of ylang ylang, in jasmine and gardenia flower oils, etc. As benzoate in oil of ylang ylang, balsam Peru, balsam Tolu, in tuberose flower oil, etc. As cinnamate in oil of styrax, balsam Peru and balsam Tolu, etc. In various oils benzyl alcohol also occurs combined with other acids.

This alcohol has been observed also as a natural constituent in the volatile flavoring oil of kirsch cherry ferments (cf. Mohler and Hämmerle¹).

Isolation.—(1) By fractionation of the original or saponified oils.

(2) By formation of complex salts: benzyl alcohol, on shaking with anhydrous calcium chloride in dry ether, forms a crystalline addition product from which the parent alcohol is regenerated by the addition of water. This procedure, however, has only limited use as many other primary alcohols form such a complex salt, but advantage may be taken of the volatility (see below).

(3) By difference in the rate of reaction with *p*-nitrobenzoyl chloride in aqueous solvents (see below).

Identification.—Benzyl alcohol can be characterized by several methods:

(1) By the preparation of derivatives.

(a) 2,4-Dinitrophenylcarbamate m. 177°, according to van Ginkel.² Prepared from the 1-(2,4-dinitrophenyl)-3-methyl-3-nitrourea.

(b) Acid phthalate. Schimmel & Co.³ reported m. 106°–107°, Bischoff and von Hedenström⁴ m. 104°, Hoejenbos and Coppens⁵ m. 106°.

(c) *p*-Nitrobenzoate m. 85°, according to Meisenheimer.⁶ Meisenheimer and Schmidt⁷ used the difference in the rate of formation of this ester as a means of separating benzyl alcohol from other alcohols.

(d) *p*-Toluene sulfonate m. 55°. Prepared by Tipson⁸ from *p*-toluene sulfonyl chloride and the alcohol in pyridine solution at –5°.

(2) On oxidation with chromic oxide and sulfuric acid, or with potassium permanganate, benzyl alcohol yields benzoic acid. Callaway and Reznek⁹ used this latter method for the quantitative determination of small amounts when the benzyl alcohol is not contaminated by other alcohols.

(3) For detecting small quantities, Pfau¹⁰ suggested identifying benzyl alcohol as dibenzyloxalate m. 79°–81°.

To about 0.03 g. of powdered anhydrous potassium carbonate add 10 drops of the fraction containing benzyl alcohol (more, if the amount of benzyl alcohol expected is less than 50%), and 5 drops of diethyloxalate. Warm in a test tube slightly over a low flame. After about 1 min. slightly cool the solid or yellow reaction mixture, add 2 cc. of water and warm the mixture until the solid compound (dibenzyloxalate) is dissolved again. After cooling in ice, the crystals formed can be recrystallized from methyl alcohol, m. 79°–81°.

If no other primary alcohols are present, which form liquid oxalates soluble in alcohol and, therefore, hinder the crystallization of dibenzyloxalate, 30% benzyl alcohol can be detected quite easily. Otherwise, it is advisable to isolate benzyl alcohol first with phthalic anhydride.

(4) Leonhardt and Wasicky¹¹ identified benzyl alcohol in essential oils in the presence of methyl alcohol and ethyl alcohol through the formation of the crystalline addition product with anhydrous calcium chloride formed by these products and taking advantage of the lower volatility of the benzyl alcohol from the complex-water mixture of these three alcohols.

(5) The use of the ultraviolet absorption spectra has been found quite helpful in connection with the determination of this compound. Mohler and Hämmerle¹² used this method to evaluate the percentage of benzyl alcohol in aqueous media, as in bitter almond water. These same authors¹³ likewise employed this technique to evaluate benzyl alcohol in an alcoholic medium, as in cherry brandy.

Properties.—Benzyl alcohol is a colorless liquid which in very pure form possesses a faint aromatic odor. The following properties have been reported by Timmermans and Hennaut-Roland,¹⁴ Gildemeister and Hoffmann,¹⁵ Hesse and Zeitschel,¹⁶ Kahlbaum,¹⁷ Deffet,¹⁸ and Lauffer:¹⁹

m.	−15.3° ^{14,18}	d_4^{30}	1.03765 ¹⁴
f.p.	−15.7° ¹⁹ (1% water content lowers this figure by several degrees)	d_4^{15}	1.04927 ¹⁴
		d_4^0	1.06095 ¹⁴
b ₇₆₂	205.50° ¹⁶	n_D^{15}	1.54259 ¹⁴
b.	205.45° ¹⁴		
b ₂₅	107° ¹⁶		
b ₁₀	92.6° ¹⁷		
Sol.	Soluble in 8 to 9 vol. of 30% alcohol, in 1.5 vol. of 50% alcohol; soluble in about 35 vol. of water ¹⁵		

On exposure to air, benzyl alcohol oxidizes slowly to benzaldehyde (odor then resembling that of bitter almond oil) and finally to benzoic acid (formation of crystals in the oil). Benzyl alcohol is only sparingly volatile with steam. The commercially available synthetic product should be free from chlorine and contain not more than a trace of benzaldehyde.

Use.—Benzyl alcohol is widely used by the perfume, cosmetic, and soap industries in the compounding of all kinds of scents, especially of synthetic

flower oils, such as jasmine, gardenia, and tuberose. It also serves as an important fixative, as a solvent of crystalline or highly viscid substances, and as a general diluent of perfume mixtures. Occasionally benzyl alcohol is encountered as an adulterant of essential oils.

- ¹ *Mitt. Lebensm. Hyg.* **30** (1939), 284.
- ² *Rec. trav. chim.* **61** (1942), 149. *Chem. Abstracts* **37** (1943), 6252.
- ³ *Ber. Schimmel & Co.*, Oct. (1903), 15.
- ⁴ *Ber.* **35** (1902), 4093.
- ⁵ *Rec. trav. chim.* **50** (1931), 1046.
- ⁶ *Liebigs Ann.* **442** (1925), 193.
- ⁷ *Ibid.* **475** (1929), 157.
- ⁸ *J. Org. Chem.* **9** (1944), 238.
- ⁹ *J. Assocn. Official Agr. Chem.* **16** (1933), 285.
- ¹⁰ *Perfumery Essential Oil Record* **16** (1925), 190.
- ¹¹ *Arch. Pharm.* **270** (1932), 249. *Ztsch. Untersuchung d. Lebensmittel*, June (1936), 597. *Deut. Parfumerieztg.*, October (1932), 364. *Chem. Abstracts* **26** (1932), 3870.
- ¹² *Z. anal. Chem.* **122** (1941), 202.
- ¹³ *Mitt. Lebensm. Hyg.* **30** (1939), 284.
- ¹⁴ *J. chim. phys.* **32** (1935), 519.
- ¹⁵ "Die Ätherischen Öle," 3d Ed., Vol. I, 447.
- ¹⁶ *J. prakt. Chem.* [2], **64** (1901), 256.
- ¹⁷ *Z. physik. Chem.* **26** (1898), 583.
- ¹⁸ *Bull. soc. chim. Belg.* **49** (1940), 223. *Chem. Abstracts* **36** (1942), 322.
- ¹⁹ *Am. Perfumer* **25** (1930), 301.

Phenylethyl Alcohol

$C_8H_{10}O$

Mol. Weight 122.16

β -Phenethyl alcohol. Benzylcarbinol. 2-Phenylethanol

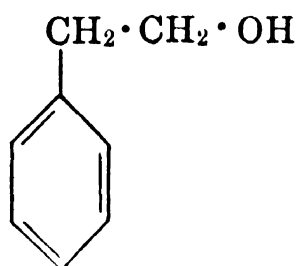

Occurrence.— β -Phenylethyl alcohol occurs in several essential oils—for example, in Bourbon geranium oil, in Aleppo pine oil, and probably as tiglate in Kivu geranium oil. Because of its relatively good solubility in water, the oils obtained by steam distillation contain much less phenylethyl alcohol than the corresponding natural flower oils extracted with volatile solvents or with hot fat (maceration). This is the case with oil (otto) of rose and concrete or absolute of rose, with neroli bigarade oil and concrete or absolute of orange flowers, most of the phenylethyl alcohol remaining in the distillation water (rose water and orange flower water). Oil of rose and oil of neroli seem to contain phenylethyl alcohol, also as esters of benzoic and phenylacetic acid. Interesting is the fact that dried rose petals contain considerable quantities of phenylethyl alcohol.

Isolation.—(1) By fractionation.

(2) Hesse and Zeitschel¹ suggested isolating phenylethyl alcohol (if no other primary alcohols are present) by preparing the crystalline addition product with anhydrous calcium chloride; this method may also serve for the purification of phenylethyl alcohol since it is easily regenerated from the calcium chloride compound by the addition of water.

(3) Britton² suggested isolating phenylethyl alcohol by the preparation of its acid phthalate with benzene as a solvent and by further reaction with an excess of sodium hydroxide (cf. Report of Odorgraphia Committee³).

Klipstein⁴ purified phenylethyl alcohol by the action of boric, phthalic, maleic, fumaric, succinic, or oxalic acid. Phenylethyl alcohol is thereby converted into stable relatively nonvolatile esters, the impurities are removed by vacuum distillation and the pure phenylethyl alcohol is recovered by hydrolysis of the esters.

Identification.— β -Phenylethyl alcohol can be characterized by several methods:

(1) By the preparation of derivatives:

(a) Diphenylurethane m. 98.5° – 99.5° , according to Hoejenbos and Coppens.⁵

(b) Acid phthalate m. 188° – 189° , according to von Soden and Rojahn.⁶

(c) 3,5-Dinitrobenzoate m. 108° , according to Ashworth and Burkhardt.⁷

(d) 2,4-Dinitrophenylcarbamate m. 111° , according to van Ginkel.⁸

(2) Walbaum⁹ found that on oxidation with 2 parts of potassium permanganate in about 60 parts of water, phenylethyl alcohol yields benzoic acid m. 122° – 123° ; with chromium trioxide and sulfuric acid, phenylethyl alcohol gives phenylacetaldehyde and phenylacetic acid m. 77° (cf. Shumeiko¹⁰).

(3) For the detection of small amounts (see also "Benzyl Alcohol"), Palfray, Sabetay and Sontag¹¹ suggested the following procedure:

Heat about 5 drops of the fraction to be tested with 0.1 g. of anhydrous oxalic acid for 1 to 2 min. over a free flame, add 1 cc. of water, then 2 cc. of alcohol; warm to dissolve the formed crystals, and allow to crystallize.

This method gives a good yield of di-(β -phenylethyl) oxalate m. 51° – 51.5° (after recrystallization from 80% alcohol).

Properties.— β -Phenylethyl alcohol is a colorless liquid, possessing a characteristic rose-like odor. Volatile with steam. The following properties have been reported by Cotton and Mouton,¹² Gildemeister and Hoffmann,¹³ Leonard,¹⁴ Grignard,¹⁵ Report Odorgraphia Committee, Associated Manufacturers of Toilet Articles,¹⁶ and Lauffer:¹⁷

m.	-25.8° ¹⁷ (with 1% water	d_4^{25}	1.018 ¹⁶
	m. -30.7°)	d_{15}^{15}	1.024 ^{13,16}
b.	217.5° – 218.5° ¹⁶	n_D^{20}	1.531 ¹⁶
b_{25}	116° – 118° ¹⁴	$n_D^{16.8}$	1.5337 ¹²
b_{14}	104° – 105° ¹⁵		
b_{10}	99° – 99.5° ¹⁶		
b_6	93° ¹³		
Sol.	Soluble in 2 vol. of 50% alcohol; in about 60 vol. of water ¹³		

The commercial synthetic product should be free from chlorine.

Use.—Phenylethyl alcohol is one of the most important aromatics used in the perfume, cosmetic, soap, and flavoring industries. It serves in all kinds of scents and is indispensable in rose compounds.

- ¹ *J. prakt. Chem.* [2], **66** (1902), 489.
- ² U. S. Patent No. 1,752,365 (to Dow Chem. Co.), 1930.
- ³ *Ind. Eng. Chem. News Ed.*, **11** (1933), 114.
- ⁴ U. S. Patent No. 2,068,415, Jan. 19, 1937 (to Calco Chem. Co.).
- ⁵ *Rec. trav. chim.* **50** (1931), 1047.
- ⁶ *Ber.* **33** (1900), 1723.
- ⁷ *J. Chem. Soc.* (1928), 1798.
- ⁸ *Rec. trav. chim.* **61** (1942), 149. *Chem. Abstracts* **37** (1943), 6252.
- ⁹ *Ber.* **33** (1900), 2300.
- ¹⁰ *J. Applied Chem. (U.S.S.R.)* **14** (1941), 93. *Chem. Abstracts* **36** (1942), 436.
- ¹¹ *Ann. chim. anal. chim. appl.* **15** (1933), 338. *Chem. Abstracts* **27** (1933), 5030.
- ¹² *Ann. chim. phys.* [8], **28** (1913), 214.
- ¹³ "Die Ätherischen Öle," 3d Ed., Vol. I, 448.
- ¹⁴ *J. Am. Chem. Soc.* **47** (1925), 1779.
- ¹⁵ *Ann. chim. phys.* [8], **10** (1907), 28.
- ¹⁶ *Ind. Eng. Chem. News Ed.* **11** (1933), 114.
- ¹⁷ *Am. Perfumer* **25** (1930), 301.

Phenylpropyl Alcohol

$C_9H_{12}O$

Mol. Weight 136.19

Hydrocinnamyl alcohol. γ -Phenyl-*n*-Propyl Alcohol. 3-Phenyl-1-propanol

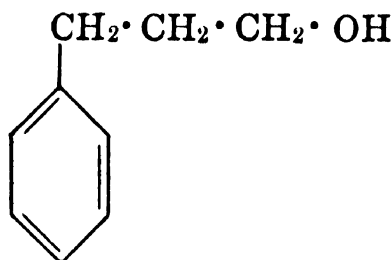

Occurrence.—Esterified with cinnamic acid, this alcohol occurs in several resins, gums, and balsams—for example, in Asiatic and American styrax; as acetate probably in oil of cassia, etc. Frequently γ -phenyl-*n*-propyl alcohol is accompanied by cinnamyl alcohol.

Isolation.—By fractionation. However, phenylpropyl alcohol thus obtained from resins, gums, and balsams cannot be freed entirely from accompanying cinnamyl alcohol by mere fractionation. Schimmel & Co.¹ purified the alcohol by heating the mixture with an equal amount of concentrated formic acid, whereby cinnamyl alcohol resinifies, while phenylpropyl alcohol is converted into the formate. Phenylpropyl alcohol can then be obtained pure by steam distillation and saponification.

Carré and Libermann² found it possible to recover 50% of the alcohol from the sulfite $(C_6H_5C_3H_6O)_2SO$, b_{11} 248°–254°, which decomposes smoothly at 310° to give an equimolecular mixture of 3-phenylpropene and 3-phenylpropanol. Other members of the sulfite series of lower molecular weight distill readily at atmospheric pressure.

Identification.— γ -Phenyl-*n*-propyl alcohol may be characterized by several methods:

(1) By the preparation of derivatives:

(a) 3,5-Dinitrobenzoate $m.$ 92°, as recorded by Huntress and Mulliken.³

(b) *p*-Nitrophenylurethane m. 104°, according to Hoeke.⁴

(c) 3-Nitrophthalate m. 117°, according to Huntress and Mulliken.⁵

(2) By oxidation. Rügheimer⁶ found that γ -phenyl-*n*-propyl alcohol, when cautiously oxidized with chromium trioxide and acetic acid, yields hydrocinnamic acid.

Properties.— γ -Phenyl-*n*-propyl alcohol is a colorless, somewhat viscid liquid possessing a faint odor, reminiscent of cinnamic alcohol and certain species of *hyacinthus*. The following properties have been reported by Law,⁷ Vavon,⁸ Brühl,⁹ Huston and Agett,¹⁰ and Gildemeister and Hoffmann:¹¹

b.	235° ⁷	d_4^{24}	1.006 ¹⁰
b ₇₄₀	233°–235° ¹⁰	d_4^{20}	1.0079 ⁹
b ₁₃	120°–121° ⁸	n_D^{23}	1.5351 ¹⁰
		n_D^{20}	1.53565 ⁹
Sol.	Soluble in about 3 vol. of 50% alcohol; in 1.5 vol. of 60% alcohol; miscible in all proportions with 70% alcohol; soluble only in more than 300 vol. of water ¹¹		

Use.— γ -Phenyl-*n*-propyl alcohol and its esters are used quite widely in the perfume, cosmetic, soap, and flavoring industries for the compounding of all kinds of scents and flavors, especially in synthetic flower oils.

¹ *Chem. Zentr.* I (1901), 69; German Patent 116,091. [Cf. Kailan and Adler, *Monatsh.* **63** (1933), 155.]

² *Bull. soc. chim.* [5], **1** (1934), 1248. *Compt. rend.* **198** (1934), 274.

³ "Identification of Pure Organic Compounds," Order I (1941), 477.

⁴ *Rec. trav. chim.* **54** (1935), 513.

⁵ "Identification of Pure Organic Compounds," Order I (1941), 477.

⁶ *Liebigs Ann.* **172** (1874), 123.

⁷ *J. Chem. Soc.* **101** (1912), 1030.

⁸ *Compt. rend.* **154** (1912), 361.

⁹ *Liebigs Ann.* **200** (1879), 191.

¹⁰ *J. Org. Chem.* **6** (1941), 128.

¹¹ "Die Ätherischen Öle," 3d Ed., Vol. I, 450.

Cinnamyl Alcohol

C₉H₁₀O

Mol. Weight 134.17

Cinnamic alcohol. γ -Phenylallyl alcohol. 3-Phenyl-2-propen-1-ol.

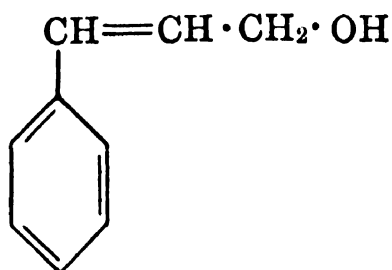

Occurrence.—Free cinnamyl alcohol has not yet been observed in nature but as ester it occurs in several essential oils, gums, balsams, and resins.

Cinnamyl cinnamate (styracine), for example, is an important constituent of styrax, balsam Peru, and other balsams and resins, whereas the acetate occurs in cassia oil.

Isolation.—The ester—for instance, cinnamyl cinnamate in styrax—is first saponified and the free cinnamyl alcohol purified through its calcium chloride addition product. According to Endoh,¹ this compound m. 157° (uncorr.) may be prepared by dissolving cinnamyl alcohol in dry ether, by adding powdered anhydrous calcium chloride, and by letting the mixture stand for 24 hr. The calcium chloride addition compound is finally hydrolyzed. Hill and Nason² used this method for the separation of cinnamyl alcohol from hydrocinnamyl alcohol.

Kharasch, May and Mayo³ obtained 90% yields of the organic sulfonate by the action of aqueous bisulfite with cinnamyl alcohol in the presence of oxygen or nitrites. This sodium salt may be recrystallized from alcohol and serves only as a means of separating the alcohol.

Identification.—Cinnamyl alcohol can be characterized by several methods:

(1) By the preparation of derivatives:

(a) 3,5-Dinitrobenzoate m. 121° , according to Huntress and Mulliken.⁴

(b) Phenylurethane m. 90° – 91.5° , according to Pauly, Schmidt and Böhme,⁵ and Schimmel & Co.⁶

(c) α -Naphthylurethane m. 114° , according to Bickel and French;⁷ m. 119° – 120° , according to Neuberg and Hirschberg.⁸

(2) By oxidation. Böhme⁹ reported the use of phthalic monoperacid as effective for the quantitative estimation of cinnamyl alcohol.

Properties.—Cinnamyl alcohol, which theoretically may exist as *cis*- or *trans*- isomers, crystallizes in long, fine, white needles. Its odor resembles that of hyacinths. The following properties have been reported by (Lauffer and Ingalls) Odorgraphia Committee,¹⁰ Perkin,¹¹ Brühl,¹² and Grédy¹³ for the commercial product which, according to the latter author, consists mostly of the *trans*- isomer:

m.	33° ^{10,13}	d_{15}^{35}	1.0338 ¹⁰
b.	257.5° ¹¹ (corr.)	d_4^{20}	1.0440 ¹²
b_{17}	142° ¹³	n_D^{20}	1.58190 ¹²
Sol.	Soluble in 3.2 vol. of 50% alcohol at 25° , in 4.2 vol. of 50% alcohol at 15° , in about 2 vol. of 60% alcohol ¹⁰		

The liquid *cis*- isomer is colorless and highly refractive. According to Grédy, this isomer synthetically prepared has these properties:

b_{10}	127°
d_4^{22}	1.041
n_D^{22}	1.5710

Use.—Cinnamyl alcohol and its esters are quite widely used in the perfume, cosmetic, and soap industries where they serve as excellent fixatives, also to impart floral, hyacinth-like notes to all kinds of scents.

- ¹ *Rec. trav. chim.* **44** (1925), 871.
- ² *J. Am. Chem. Soc.* **46** (1924), 2245.
- ³ *J. Org. Chem.* **3** (1938), 175.
- ⁴ "Identification of Pure Organic Compounds," Order I (1941), 412.
- ⁵ *Ber.* **57** (1924), 1329.
- ⁶ *Ber. Schimmel & Co.*, April (1910), 174.
- ⁷ *J. Am. Chem. Soc.* **48** (1926), 749.
- ⁸ *Biochem. Z.* **27** (1910), 343.
- ⁹ *Ber.* **70B** (1937), 379.
- ¹⁰ *Ind. Eng. Chem. News Ed.* **11** (1933), 114.
- ¹¹ *J. Chem. Soc.* **69** (1896), 1228.
- ¹² *Liebigs Ann.* **235** (1886), 17.
- ¹³ *Bull. soc. chim.* [5], **3** (1936), 1098.

Cuminy Alcohol

$C_{10}H_{14}O$

Mol. Weight 150.21

Cuminic alcohol. Cumic alcohol. *p*-Isopropylbenzyl alcohol

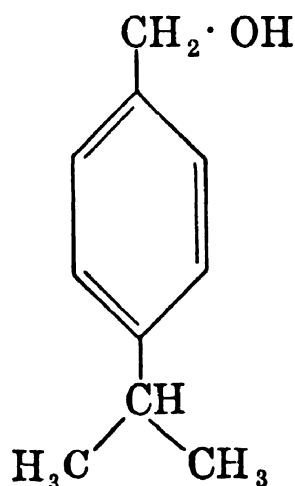

Occurrence.—Cuminy alcohol seems to be a minor constituent only of a few essential oils where it occurs in free and in esterified form. Seidel, Schinz and Müller¹ isolated small quantities of free cuminy alcohol from French lavender oil. Penfold² observed the presence of this alcohol (as ester) in the volatile oil derived from the leaves of *Eucalyptus Bakeri* Maiden.

Isolation.—By fractional distillation of the essential oil *in vacuo*, preparation of the acid phthalate, and repeated fractionation of the regenerated alcohol. The cuminy alcohol may be purified through its allophanate (see below).

Identification.—In the course of their research on the composition of French lavender oil, Seidel, Schinz and Müller³ noted that the melting points of certain derivatives of cuminy alcohol given by earlier workers differed from their own findings. To clarify these discrepancies, Seidel, Schinz and Müller⁴ purified the natural alcohol (from

lavender oil) most carefully, also synthesized cuminyl alcohol by several different methods, and prepared pure derivatives by repeated crystallization in various solvents:

(1) Allophanate m. 184° – 185° (after four recrystallizations from cyclohexane-petroleum ether). Earlier, Mastagli⁵ had reported a melting point of 201° .

(2) 3,5-Dinitrobenzoate m. 95° – 96° (after two recrystallizations from cyclohexane-petroleum ether). Earlier, Cooke⁶ had recorded a melting point of 107° .

(3) Phenylurethane m. 55° (after three recrystallizations from methyl alcohol). Earlier, Cooke,⁷ as well as Mastagli,⁸ had noted a melting point of 62° .

Properties.—Cuminyl alcohol is a colorless to yellowish oil. The following properties have been reported by Perkin,⁹ Semmler,¹⁰ von Rechenberg,¹¹ Kraut,¹² Bert,¹³ Palfray, Sabetay and Mastagli,¹⁴ Anschütz and Reiter,¹⁵ Mastagli,¹⁶ and Seidel, Schinz and Müller:¹⁷

b.	248.4° – 248.9° (corr.) ⁹	d_{25}^{25}	0.9753 ⁹
	246.6° ^{11, 12, 15}	$d_4^{18.4}$	0.9818 ^{14, 16}
	246.0° (corr.) ¹³	d_{15}	0.9775 ¹²
b_{20}	140° ¹³	d_{15}^{15}	0.9805 ⁹
b_{13}	122.5° ^{14, 16}	d_4^{14}	0.983 ¹³
	124° ¹⁷		0.9796 ¹⁷
b_{12}	130.2° – 130.4° ¹⁵	d_4^4	0.9869 ⁹
	121° – 124° ¹⁷	d	0.978 ¹⁰
b_{11}	120° – 121° ¹⁷	$n_D^{19.5}$	1.5210 ^{14, 16}
		n_D^{14}	1.5183 ¹⁷
			1.528 ¹³
		n_D	1.5217 ¹⁰

Use.—Little is known about the use of cuminyl alcohol in our industries.

¹ *Helv. Chim. Acta* **27** (1944), 663.

² *J. Proc. Roy. Soc. N. S. Wales* **61** (1927), 179.

³ *Helv. Chim. Acta* **27** (1944), 671.

⁴ *Ibid.*, 672.

⁵ *Ann. chim.* [11], **10** (1938), 302.

⁶ *J. Chem. Soc.* (1938), 1825.

⁷ *Ibid.*

⁸ *Ann. chim.* [11], **10** (1938), 302.

⁹ *J. Chem. Soc.* **69** (1896), 1198.

¹⁰ *Ber.* **33** (1900), 1461.

¹¹ "Einfache und fraktionierte Destillation in Theorie und Praxis," Schimmel & Co., Leipzig (1923), 262.

¹² *Liebigs Ann.* **192** (1878), 224.

¹³ *Compt. rend.* **177** (1923), 452. *Bull. soc. chim.* [4], **37** (1925), 1577.

¹⁴ *Compt. rend.* **203** (1936), 1523.

¹⁵ "Die Destillation unter vermindertem Druck," 2d Ed. (1895), through von Rechenberg, "Einfache und fraktionierte Destillation in Theorie und Praxis," Schimmel & Co., Leipzig (1923), 299.

¹⁶ *Ann. chim.* [11], **10** (1938), 281.

¹⁷ *Helv. Chim. Acta* **27** (1944), 672.

E. MISCELLANEOUS ALCOHOLS

Cryptol

 $C_9H_{16}O$

Mol. Weight 140.22

4-Isopropyl-2-cyclohexen-1-ol

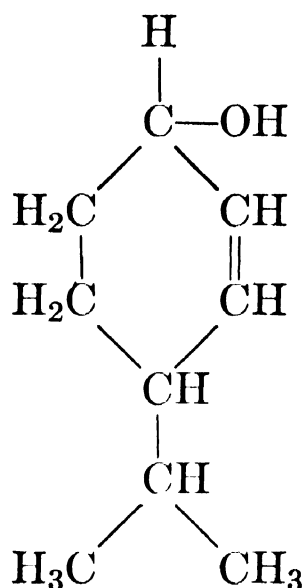

Galloway, Dewar and Read¹ prepared *l*-cryptol by the reduction of *l*-cryptone (see "Cryptone") with the Ponndorf reagent. Purified through its *p*-nitrobenzoate m. 84°, $[\alpha]_D -168^\circ 30'$ ($c = 2.1$ in chloroform), *l*-cryptol had these properties:

b_8	97°
$[\alpha]_D$	-139° 20' ($c = 2$ in alc.)
n_D^{21}	1.4771

It could be characterized by the preparation of these derivatives:

- (1) 3,5-Dinitrobenzoate m. 115° (Galloway, Dewar and Read)
- (2) Phenylurethane m. 105° (Gillespie, Macbeth and Swanson²)
- (3) α -Naphthylurethane m. 118° (Gillespie, Macbeth and Swanson).

Macbeth and Winzor³ prepared *d*-cryptol from *d*-cryptone by a similar method and noted these properties:

b_2	72°
$[\alpha]_D^{25}$	+146° 24' ($c = 2.2$ in alc.)
n_D^{20}	1.4796

Wienhaus and Striegler⁴ reported the probable occurrence of *d*-4-isopropyl-2-cyclohexen-1-ol (*d*-cryptol) in the oil derived from water fennel (*Phelandrium aquaticum* L.).

¹ *J. Chem. Soc.* (1936), 1595.

² *Ibid.* (1938), 1820.

³ *Ibid.* (1939), 264.

⁴ *Ber. Schimmel & Co.* (1937), 91.

α - and β - Δ^{16} -Androstenol $C_{19}H_{30}O$

Mol. Weight 274.43

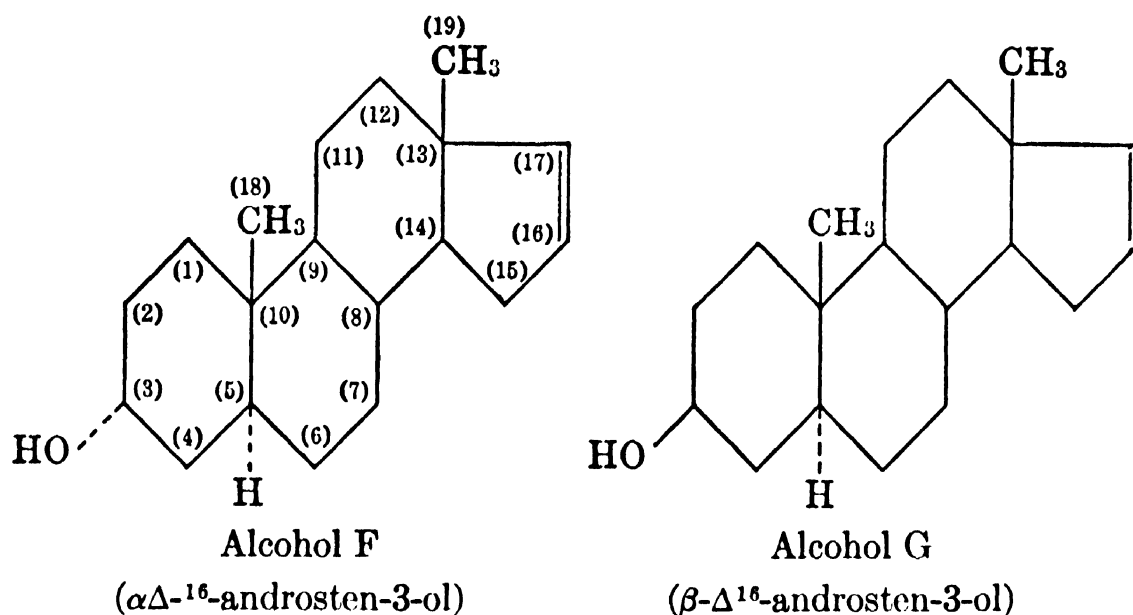

Occurrence.— α - and β - Δ^{16} -Androstenol occur in the testes of swine.

Isolation.—By chromatographic separation on aluminum oxide (Al_2O_3) in petroleum ether-benzene (1:1) mixture.

Properties.—According to Prelog and Ruzicka,¹ α - and β - Δ^{16} -androstenol have these properties:

Alcohol F

m.	142.5°–143°
$[\alpha]_D^{20}$	+13° 6' (± 2)

Alcohol G

m.	123°
$[\alpha]_D^{20}$	+6° 30' (± 2)

The odor of α - and β - Δ^{16} -androstenol resembles that of musk but is more animal-like and closer to natural musk than the purified ring ketones civetone and muscone which possess a somewhat sweet and flowery note. The odor of the α - alcohol is stronger than that of its epimer β -; the latter has even been described as odorless. The corresponding ketones smell stronger than the alcohols and are more offensive.

The relation of α - and β - Δ^{16} -androstenol to civetone is interesting in so far as these epimeric alcohols can be visualized as derived from civetol by ring

closures; thus they could correspondingly be named as dimethyl tetracyclo-civetol or dimethyl tetracycloheptadecenol.

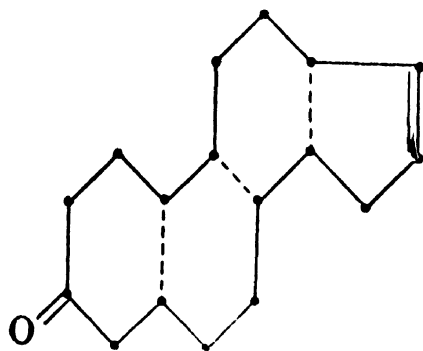

Civetone

Prelog, Ruzicka and Weiland² succeeded in synthesizing α - and β - Δ^{16} -androsthenol from androstan-ol-17 β -one-3-hexahydrobenzoate.

Use.—The literature does not reveal details of the use of 3- α - and β - Δ^{16} -androsthenols.

¹ *Helv. Chim. Acta* **27** (1944), 65.

² *Ibid.* **27** (1944), 66.

III. ALDEHYDES

A. ALIPHATIC ALDEHYDES

Introduction.—With the exception of citral and citronellal, which will be described in more detail, these aldehydes do not play an important role in

essential oils. The lowest members of this series, viz., formaldehyde $\text{H} \cdot \overset{\text{H}}{\text{C}}=\text{O}$,

and acetaldehyde $\text{CH}_3 \cdot \overset{\text{H}}{\text{C}}=\text{O}$, occur frequently in the distillation waters of volatile oils; they are probably products of decomposition and degradation of more complex compounds in the course of steam distillation. Due to their solubility in water, these aldehydes remain dissolved in the distillation water but may accumulate in the oil of cohobation if the distillation waters are redistilled (cohobated).

It is not the purpose of this work to record all properties and methods of isolation pertaining to the lower aliphatic aldehydes as these data may be obtained readily in any modern standard book on organic chemistry or qualitative organic analysis. Special mention may be made of certain recent volumes that should prove to be particularly useful as adjuncts to this phase of diagnosis. Huntress and Mulliken's excellent work, "Identification of Pure Organic Compounds," Wiley, 1941; and Heilbron's three-volume treatise, "Dictionary of Organic Compounds," revised in 1943, are especially to be recommended for their extended lists of derivatives and for general properties of organics; Karrer's treatise, "Organic Chemistry," on general reactions is a valuable aid; Meyer's "Analyse und Konstitutions-Ermittlung organischer Verbindungen" relates to analytical methods. It will suffice, therefore, to touch on the members of this group only briefly. Propionaldehyde

(propanal) $\text{C}_2\text{H}_5 \cdot \overset{\text{H}}{\text{C}}=\text{O}$, butyraldehyde (butanal) $\text{C}_3\text{H}_7 \cdot \overset{\text{H}}{\text{C}}=\text{O}$, valeraldehyde

(pentanal) $\text{C}_4\text{H}_9 \cdot \overset{\text{H}}{\text{C}}=\text{O}$, isovaleraldehyde, and caproaldehyde (hexanal)

$\text{C}_5\text{H}_{11} \cdot \overset{\text{H}}{\text{C}}=\text{O}$ occur in the foreruns of several volatile oils, for example, in eucalyptus and peppermint oils. Because of their irritating, cough-provoking vapor, they tend to impart to the oil a disagreeable character and should, therefore, be removed by fractionation of the crude oil. Heptaldehyde (heptanal, enanthal) possesses a pronounced fatty odor.

Much more important are the higher aliphatic aldehydes, especially *n*-octyl-

aldehyde (octanal, caprylaldehyde) $C_7H_{15} \cdot \overset{\text{H}}{\text{C}}=\text{O}$, *n*-nonylaldehyde (nonanal,

pelargonaldehyde) $C_8H_{17} \cdot \overset{\text{H}}{\text{C}}=\text{O}$, and *n*-decylaldehyde (decanal) $C_9H_{19} \cdot \overset{\text{H}}{\text{C}}=\text{O}$.

Owing to their powerful and characteristic odor, these aldehydes play a very definite role in the odor and flavor of an oil, although the oil may contain only traces of these aldehydes. Such is the case, for example, with nonylaldehyde occurring in orris root, rose, and probably lemon oil, with decylaldehyde in oil of neroli bigarade, sweet orange, and coriander seed. In some cases the immature plant—coriander, for instance—contains a much larger percentage of these aldehydes than the matured plant (seed in this case); in other words, the aldehyde seems to be a precursor in the biochemical reactions leading to terpene alcohols and esters. If such plants or parts of plants are distilled prematurely, the odor and flavor of the resulting oil may be entirely different from that of the oil derived from well matured plants (seed); in fact, such an oil may be completely unusable. Due to their powerful odor, even a slight excess of these aldehydes above the normal content, which is usually very small, may completely change the odor characteristics of the oil. Most of these aldehydes are now obtainable by synthetic methods; therefore, they form valuable adjuncts in the compounding of artificial oils, flavors, and scents in general.

Unsaturated lower aliphatic aldehydes, too, occur in some essential oils, the most important representative probably being α , β -hexenal (β -propyl-

acrolein) $CH_3 \cdot CH_2 \cdot CH_2 \cdot \overset{\text{H}}{\text{C}}=\text{CH} \cdot \text{C}=\text{O}$, the so-called leaf aldehyde which has been obtained by steam distillation of green leaves and which possesses a pronounced odor of green foliage.

In general, these compounds give all the ordinary reactions of the aliphatic aldehydes, viz., formation of cyanohydrins, bisulfite complexes, oxidation to acids (reduction of ammoniacal silver and copper solutions), polymerization (especially lower members of the series), and reduction to alcohols. All these reactions may play an important role in connection with isolation or diagnostic procedures.

Moreover, these compounds readily yield many crystalline derivatives from the carbonyl group as oximes, semicarbazones, anilides, and substituted hydrazones. These latter compounds have been particularly well investigated in the recent past and now appear as preferred derivatives because of their insolubility, high melting points, and speed of reaction. In this regard they have now replaced the oximes and semicarbazones so often met

with in earlier analytical studies, in fact the nitrophenylhydrazones have even found a basis in quantitative chemical analysis of several organics.

SUGGESTED ADDITIONAL LITERATURE

E. C. Horning and M. G. Horning, "Methone Derivatives of Aldehydes," *J. Org. Chem.* **11** (1946), 95. *Chem. Abstracts* **40** (1946), 3097.

(a) SATURATED ALIPHATIC ALDEHYDES.

Formaldehyde

CH₂O

Mol. Weight 30.03

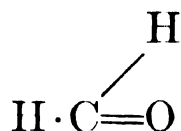

Occurrence.—Formaldehyde has been reported to occur in several volatile oils and their distillation waters, but in most cases this aldehyde was characterized by simple color reactions. Curtius and Franzen¹ claimed that for the definite identification of formaldehyde in essential oils or their distillation waters it would be necessary first to remove the volatile acids and subsequently to oxidize the formaldehyde with silver oxide into formic acid which can be determined as such.

Isolation.—The method to be employed will be conditioned by the surrounding medium—as this aldehyde is readily volatile with steam and depolymerized with aqueous acids; therefore, trial should first be made to obtain its solutions of the aqueous monomer by steam distilling in presence of phosphoric acid. The aqueous layer may be used to evaluate the formaldehyde by precipitation of the phloroglucinol complex (cf. Meyer²) or by hydrogen peroxide titration (cf. *Assocn. of Official Agricultural Chemists*³).

Identification.—Formaldehyde can be characterized by several methods:

(1) By color reactions:

(a) Formaldehyde reduces Fehling's solution, and forms a silver mirror with Tollen's reagent. It gives the resorcin and phenolphthalein reactions, both of which yield red to violet tinted condensation products.

(b) When qualitative tests of high sensitivity are required, the phenylhydrazine hydrochloride, Hehner, phloroglucinol or Leach tests may be employed (cf. *Assocn. of Official Agricultural Chemists*⁴).

(2) By the preparation of derivatives:

(a) *p*-Nitrophenylhydrazone m. 181°–182° (yellow needles from benzene), according to Bamberger.⁵ Even dilute solutions of formaldehyde react with *p*-nitrophenylhydrazine hydrochloride on standing or warming.

(b) 2,4-Dinitrophenylhydrazone m. 167° (from alcohol), according to Bryant.⁶

Properties.—Pure formaldehyde gas boils at -21° , d_{-20} 0.8153. An aqueous solution containing 30 per cent formaldehyde forms a constant boiling mixture b. 98.8° . It has a sharp odor irritating the mucous membranes.

Soluble in water. The 40 per cent solution in water is commercially known as "Formalin" (cf. Walker ⁷).

Use.—Formaldehyde is used as a powerful disinfectant in numerous industrial products and pharmaceutical preparations.

¹ *Ber.* **45** (1912), 1715.

² "Analyse und Konstitutions-Ermittlung organischer Verbindungen," 3d Ed. (1916).

³ "Methods of Analysis," 1940 Ed., 68.

⁴ *Ibid.* 460.

⁵ *Ber.* **32** (1899), 1807.

⁶ *J. Am. Chem. Soc.* **54** (1932), 3760.

⁷ *Ind. Eng. Chem. Ind. Ed.* **23** (1931), 1220. *J. Am. Chem. Soc.* **55** (1933), 2821.

Acetaldehyde

C₂H₄O

Mol. Weight 44.05

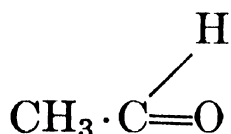

Occurrence.—Acetaldehyde has been observed in the first fractions of several essential oils and in their distillation waters—for example, in oil of anise, caraway, camphor, orris root, and peppermint.

Isolation.—Through the bisulfite compound, with quantitative assay effected by titration of excess bisulfite with iodine according to Ripper,¹ Fürth and Charnass,² and Parkinson and Wagner.³

Identification.—Acetaldehyde can be characterized by several methods:

(1) By color reactions:

(a) Acetaldehyde reduces Fehling's solution, or Tollen's reagent.

(b) On treatment with 10% sodium nitroprusside solution and piperidine, acetaldehyde gives a deep blue color (Simon's test). According to Lewin,⁴ propionaldehyde and acrolein, too, develop this color whereas formaldehyde does not give the reaction.

(2) By the preparation of derivatives:

(a) *p*-Nitrophenylhydrazone m. 128.5°, according to Hyde.⁵

(b) *p*-Iodobenzoylhydrazone m. 224° (corr.), by Sah and Hsü.⁶

Properties.—In dilution acetaldehyde has a rather agreeable odor but in concentrated form it irritates the mucous membranes. The following properties have been recorded by Maass and Boomer,⁷ and de Leeuw:⁸

m.	−123.3° ⁸	d ₄ ^{0.1}	0.809 ⁷
b.	20.8° ⁷	n _D ¹⁸	1.3392 ⁸

Acetaldehyde is miscible with water but can be salted out with calcium chloride; miscible with alcohol or ether. Readily volatile with steam.

Use.—Acetaldehyde, as such, is sparingly used in the flavor industry.

¹ *Monatsh.* **21** (1900), 1079.

² *Biochem. Z.* **26** (1910), 207.

- ³ *Ind. Eng. Chem. Anal. Ed.* **6** (1934), 433. Cf. Meyer, "Analyse und Konstitutions-Ermittlung organischer Verbindungen" (1916).
⁴ *Ber.* **32** (1899), 3388. Cf. also van Urk, *Pharm. Weekblad* **62** (1925), 2. *Chem. Zentr. I* (1925), 993.
⁵ *Ber.* **32** (1899), 1813.
⁶ *Rec. trav. chim.* **59** (1940), 349.
⁷ *J. Am. Chem. Soc.* **44** (1922), 1718.
⁸ *Z. physik. Chem.* **77** (1911), 302, 311.

Propionaldehyde

C₃H₆O

Mol. Weight 58.08

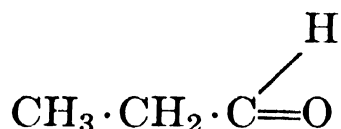

Occurrence.—Propionaldehyde has been observed in the first runs of Finnish pine oil ("Kienöl").

Isolation.—With saturated aqueous sodium bisulfite, propionaldehyde yields a crystalline bisulfite compound sparingly soluble in ethyl alcohol which may be used for the quantitative determination of this aldehyde.

Identification.—(1) Colorimetric reaction:

Propionaldehyde gives the silver mirror test with Tollen's reagent.

(2) By the preparation of derivatives:

(a) *p*-Nitrophenylhydrazone m. 125° (yellow needles from 50% alcohol), according to Bauer and Strauss.¹

(b) 2,4-Dinitrophenylhydrazone m. 155°, according to Allen.²

(c) *p*-Iodobenzoylhydrazone m. 196° (corr.), by Sah and Hsü.³

Properties.—Voellmy,⁴ Linnemann,⁵ and Walden⁶ recorded these properties:

m.	−81° ⁶	d ₄ ²¹	0.8074 ⁵
b ₇₃₉	48.1°–49.1° ⁵	n ₅₈₀ ^{16.6}	1.3695 ⁴

Propionaldehyde is soluble in 5 parts of water at 20°. Volatile with steam. The odor resembles that of acetaldehyde.

¹ *Ber.* **65** (1932), 311. Cf. also Griebel and Weiss, *Mikrochemie* **5** (1928), 157. *Chem. Zentr. I* (1928), 385. Cf. Harries and Oppenheim, *Chem. Zentr. II* (1916), 991.

² *J. Am. Chem. Soc.* **52** (1930), 2957.

³ *Rec. trav. chim.* **59** (1940), 349.

⁴ *Z. physik. Chem.* **127** (1927), 345.

⁵ *Liebigs Ann.* **161** (1872), 22.

⁶ *Z. Physikal. Chem.* **55** (1906), 220.

***n*-Butyraldehyde**C₄H₈O

Mol. Weight 72.10

(Butanal)

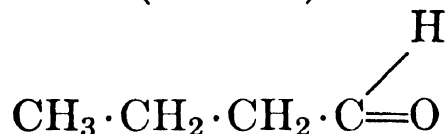

Occurrence.—Butyraldehyde has been identified in oil of cajuput, California *Eucalyptus globulus*, and *Monarda fistulosa*.

Isolation.—Through the bisulfite compound which *n*-butyraldehyde forms with sodium bisulfite in saturated aqueous solution, and which may be used for the quantitative determination of this aldehyde.

Identification.—By the preparation of derivatives:

- (1) *p*-Nitrophenylhydrazone m. 91°–92°, according to Dakin.¹
- (2) 2,4-Dinitrophenylhydrazone m. 123° (from alcohol), according to Bryant.²
- (3) *p*-Iodobenzoylhydrazone m. 201° (corr.), by Sah and Hsü.³

Properties.—Timmermans,⁴ and Hartung and Adkins⁵ recorded these properties:

b.	74.7° ⁴
d ₄ ²⁵	0.7988 ⁵
n _D ²⁵	1.3750 ⁵

n-Butyraldehyde is soluble in 27 parts of water. With water it forms a constant boiling mixture. Oxidation with alkaline potassium permanganate yields *n*-butyric acid.

¹ *J. Biol. Chem.* **4** (1908), 235. Cf. Harries and Oppenheim, *Chem. Zentr* II (1916), 992.

² *J. Am. Chem. Soc.* **54** (1932), 3760.

³ *Rec. trav. chim.* **59** (1940), 349.

⁴ *Bull. soc. chim. Belg.* **36** (1927), 506.

⁵ *J. Am. Chem. Soc.* **49** (1927), 2520.

***n*-Valeraldehyde**C₅H₁₀O

Mol. Weight 86.13

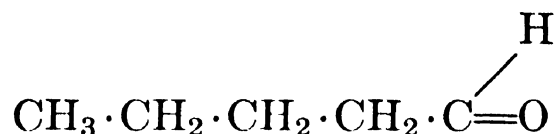

Occurrence.—This aldehyde probably occurs in oil of iva.

Isolation.—With sodium bisulfite in saturated aqueous solution, this aldehyde yields a sparingly soluble bisulfite compound.

Identification.—By the preparation of derivatives:

- (1) 2,4-Dinitrophenylhydrazone m. 98° (crystallized from alcohol),* according to Allen.¹

* According to Airs, Firth and Garner, valeraldehyde yields a 2,4-dinitrophenylhydrazone m. 107.6° (corr.), variously given as 88°, 98° and 106.5°–107°. *J. Chem. Soc.* (1946), 1089. *Chem. Abstracts* **41** (1947), 1602.

- (2) *p*-Nitrophenylhydrazone m. 74°–75°, by Schmidt, Peterson and Fred.²
 (3) *p*-Iodobenzoylhydrazone m. 152° (corr.), by Sah and Hsü.³
 (4) Hydrazone from 1-methyl-3-carbohydrazidopyridinium *p*-toluene sulfonate m. 142° (corr.), by Allen and Gates.⁴

Properties.—Simon,⁵ Bruylants and Ernould,⁶ and Zander⁷ reported these properties:

m.	−91.5° ⁵	d_4^{20}	0.80952 ⁶
b.	103.4° ⁷	$d_{11.2}$	0.8185 ⁷
	103.7° ⁵	n_D^{20}	1.39436 ⁶
		n_D^{15}	1.40800 ⁵

n-Valeraldehyde is sparingly soluble in water. With water it forms a constant boiling mixture b_{747} 80.6° containing 86 per cent of *n*-valeraldehyde by volume. The odor of *n*-valeraldehyde is sharp and penetrating.

¹ *J. Am. Chem. Soc.* **52** (1930), 2957.

² *J. Biol. Chem.* **61** (1924), 170. Sen, *Biochem. Z.* **140** (1923), 452.

³ *Rec. trav. chim.* **59** (1940), 349.

⁴ *J. Org. Chem.* **6** (1941), 599.

⁵ *Bull. soc. chim. Belg.* **38** (1929), 56.

⁶ *Bull. sci. acad. roy. Belg.* [5] **17** (1931), 1174.

⁷ *Liebigs Ann.* **224** (1884), 81.

Isovaleraldehyde

C₅H₁₀O

Mol. Weight 86.13

2-Methyl-*n*-butyraldehyde. 3-Methylbutanal

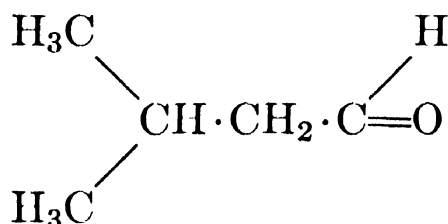

Occurrence.—This aldehyde occurs in several volatile oils and usually can be recognized by its disagreeable cough-provoking vapor. For this reason the aldehyde should be removed by fractionation of the oils. Isovaleraldehyde has been observed in American and French peppermint oils, in oil of *Eucalyptus globulus*, cajuput, niaouli, clove, Java citronella, East Indian sandalwood, and in a few other volatile oils.

Isolation.—Through the sparingly soluble bisulfite compound which isovaleraldehyde forms with sodium bisulfite in saturated aqueous solution.

Identification.—By the preparation of derivatives:

(1) 2,4-Dinitrophenylhydrazone m. 123° (crystallized from alcohol), according to Allen.¹

(2) *p*-Iodobenzoylhydrazone m. 218°–219° (corr.), by Sah and Hsü.²

(3) Hydrazone from 1-methyl-3-carbohydrazidopyridinium *p*-toluene sulfonate m. 159° (corr.) by Allen and Gates.³

Properties.—Harries and Oppenheim,⁴ and Bhagwat⁵ recorded these properties:

b_{684}	88.5°–89.5° ⁵
d_{20}^{20}	0.7845 ⁴
d^0	0.8212 ⁵
n_D^{20}	1.39023 ⁴

Oxidation of isovaleraldehyde yields isovaleric acid.

¹ *J. Am. Chem. Soc.* **52** (1930), 2957.

² *Rec. trav. chim.* **59** (1940), 349.

³ *J. Org. Chem.* **6** (1941), 599.

⁴ *Chem. Zentr.* II (1916), 992.

⁵ *J. Chem. Soc.* **123** (1923), 1805.

n-Caproaldehyde

$C_6H_{12}O$

Mol. Weight 100.16

Caproic aldehyde Hexanal.

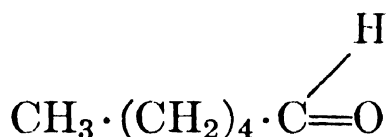

Occurrence.—*n*-Caproaldehyde occurs in oil of *Eucalyptus globulus* and in the oils derived from other eucalyptus species. Together with butyraldehyde and isovaleraldehyde it causes the disagreeable cough-provoking property of certain eucalyptus oils which should be eliminated by rectification of the crude oils.

Isolation.—Through the sparingly soluble bisulfite compound which *n*-caproaldehyde forms with sodium bisulfite in saturated aqueous solution.

Identification.—By the preparation of derivatives:

(1) 2,4-Dinitrophenylhydrazone m. 106°–107°, according to Newman.¹

(2) *p*-Iodobenzoylhydrazone m. 148°–149° (corr.), by Sah and Hsü.²

(3) Hydrazone from 1-methyl-3-carbohydrazidopyridinium *p*-toluene sulfonate m. 153° (corr.), by Allen and Gates.³

Properties.—Bachman⁴ and Bruylants⁵ reported these properties:

b.	126°–129° ⁴	d_4^{20}	0.8139 ⁵
	128.1° ⁵	n_D^{20}	1.4039 ⁵

n-Caproaldehyde readily oxidizes to *n*-caproic acid even on exposure to air.

¹ *J. Am. Chem. Soc.* **57** (1935), 734.

² *Rec. trav. chim.* **59** (1940), 349.

³ *J. Org. Chem.* **6** (1941), 599.

⁴ "Organic Syntheses," Coll. Vol. II, New York, John Wiley, p. 324.

⁵ *Bull. soc. chim. Belg.* **41** (1932), 334.

Enanthaldehyde

C₇H₁₄O

Mol. Weight 114.18

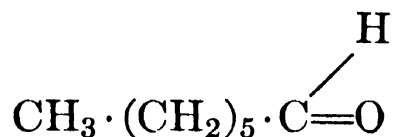
n-Heptaldehyde. Heptanal

Occurrence.—This aldehyde does not seem to occur as such in essential oils although its occurrence in certain oxidized and pyrolyzed fatty oils is recognized.

Isolation.—Through the crystalline bisulfite compound which enanthaldehyde forms with sodium bisulfite in saturated aqueous solution, and which may be used also for the quantitative determination of this aldehyde.

Identification.—By the preparation of derivatives:

- (1) Hydrazone from 1-methyl-3-carbohydrazidopyridinium *p*-toluene sulfonate, m. 160° (corr.), by Allen and Gates.¹
- (2) *p*-Iodobenzoylhydrazone m. 190°–191° (corr.), by Sah and Hsü.²
- (3) 2,4-Dinitrophenylhydrazone m. 108° (crystallized from alcohol), according to Campbell.³

Properties.—Gildemeister and Hoffmann,⁴ Hartung and Adkins,⁵ and Defet⁶ reported the following properties:

m.	−43.3° ⁶	n _D ²⁵	1.4077 ⁵
b ₇₅₉	153°–155° ⁴	n _D ²⁰	1.412–1.414 ⁴
d ₄ ³⁰	0.80902 ⁶		
d ₄ ¹⁵	0.82162 ⁶		
d ₄ ⁰	0.83423 ⁶		
Sol.	Soluble in about 12 vol. of 50% alcohol; soluble in 4 vol. of 60% alcohol ⁴		

Enanthaldehyde has a penetrating, characteristic fatty odor. Oxidation with potassium permanganate yields *n*-heptanoic acid.

Use.—Enanthaldehyde is used mainly in imitation cognac oils. Because of its powerful odor, enanthaldehyde is also used in deodorants designed for overcoming undesirable notes in technical preparations.

¹ *J. Org. Chem.* **6** (1941), 599.

² *Rec. trav. chim.* **59** (1940), 349.

³ *Analyst* **61** (1936), 392.

⁴ "Die Ätherischen Öle," 3d Ed., Vol. I, 507.

⁵ *J. Am. Chem. Soc.* **49** (1927), 2520.

⁶ *Bull. soc. chim. Belg.* **40** (1931), 390.

n-CaprylaldehydeC₈H₁₆O

Mol. Weight 128.21

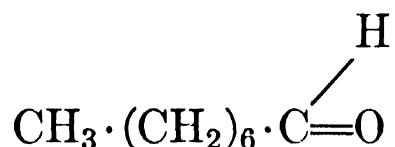
Caprylic aldehyde. *n*-Octylaldehyde. Octanal

Occurrence.—This aldehyde occurs in oil of lemongrass, probably also in oil of lemon.

Isolation.—Through the sodium bisulfite compound.

Identification.—By the preparation of derivatives:

- (1) *p*-Nitrophenylhydrazone m. 80°, according to Stephen.¹
- (2) 2,4-Dinitrophenylhydrazone m. 106° (crystallized from alcohol), according to Allen.²
- (3) *p*-Iodobenzoylhydrazone m. 155° (corr.), by Sah and Hsü.³
- (4) Hydrazone from 1-methyl-3-carbohydrazidopyridinium *p*-toluene sulfonate m. 154° (corr.), by Allen and Gates.⁴

Properties.—Gildemeister and Hoffmann,⁵ Semmler,⁶ Harries and Oppenheim,⁷ and Schimmel & Co.⁸ reported these properties:

b.	171°–173° ⁷	n _D ²⁶	1.41667 ⁸
b ₉	60°–61° ⁶	n _D ²⁰	1.42167 ⁷
d ₂₀	0.8211 ⁶		
d ₁₅ ¹⁵	0.827 ⁵		

n-Caprylaldehyde has an odor similar to that of enanthaldehyde. Volatile with steam. Oxidation with potassium permanganate yields *n*-caprylic acid.

Use.—*n*-Caprylaldehyde is used very sparingly in imitation citrus oils, especially lemon and orange.

¹ *J. Chem. Soc.* **127** (1925), 1875.

² *J. Am. Chem. Soc.* **52** (1930), 2957.

³ *Rec. trav. chim.* **59** (1940), 349.

⁴ *J. Org. Chem.* **6** (1941), 599.

⁵ "Die Ätherischen Öle," 3d Ed., Vol. I, 507.

⁶ *Ber.* **42** (1909), 1161.

⁷ *Chem. Zentr.* II (1916), 993.

⁸ *Ibid.* II (1901), 1375.

Pelargonaldehyde

 $C_9H_{18}O$

Mol. Weight 142.23

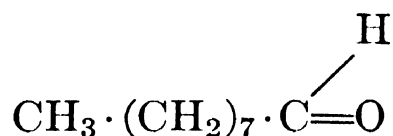
n-Nonylaldehyde. Nonanal

Occurrence.—Pelargonaldehyde occurs in oil of orris root, cinnamon, lemongrass, mandarin, in certain types of rose oil, and probably also in oil of lemon.

Isolation.—Through the bisulfite compound which pelargonaldehyde forms with sodium bisulfite in saturated aqueous solution.

Identification.—By the preparation of derivatives:

- (1) 2,4-Dinitrophenylhydrazone m. 96° , according to Allen.¹
- (2) *p*-Iodobenzoylhydrazone m. 135° – 136° (corr.), according to Sah and Hsü.²
- (3) Hydrazone from 1-methyl-3-carbohydrazidopyridinium *p*-toluene sulfonate m. 152° (corr.) by Allen and Gates.³

Properties.—Walbaum and Stephan⁴ reported for pelargonaldehyde as isolated from German rose oil:

b_{13}	80° – 82°
d_{15}	0.8277
n_D^{16}	1.42452

Sabatier and Mailhe,⁵ and Holde and Zadek⁶ reported the following properties:

$b.$	185° ⁵	$d_{17.5}$	0.839 ⁶
b_{12}	80° – 83° ⁶	$n_D^{17.5}$	1.4276 ⁶

Pelargonaldehyde has a powerful odor somewhat reminiscent of rose, but with a fatty by-note. Oxidation of pelargonaldehyde yields pelargonic acid.

Use.—Pelargonaldehyde is used widely but most sparingly as an adjunct in all kinds of perfume compositions, especially the floral types, such as rose. It also serves to great advantage in the compounding of certain artificial essential oils.

¹ *J. Am. Chem. Soc.* **52** (1930), 2957.

² *Rec. trav. chim.* **59** (1940), 352.

³ *J. Org. Chem.* **6** (1941), 599.

⁴ *Ber.* **33** (1900), 2302.

⁵ *Compt. rend.* **158** (1914), 987.

⁶ *Ber.* **56** (1923), 2056.

n-DecylaldehydeC₁₀H₂₀O

Mol. Weight 156.26

Capric aldehyde. Decanal

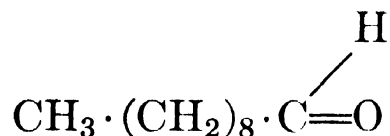

Occurrence.—*n*-Decylaldehyde has been observed in oil of orris root, *Abies alba*, savin, lemongrass, sweet orange, neroli bigarade, mandarin, coriander, acacia flower oil, and in a few other oils.

Isolation.—Through the sodium bisulfite compound which *n*-decylaldehyde forms with sodium bisulfite in saturated aqueous solution, and which can be decomposed by treatment with aqueous sodium carbonate. According to Dodge,¹ this method may be used to separate *n*-decylaldehyde from citronellal or from citral.

Identification.—By the preparation of derivatives:

- (1) Thiosemicarbazone m. 99°–100°, according to Uhl.²
- (2) 2,4-Dinitrophenylhydrazone m. 104°, according to Allen.³
- (3) *p*-Iodobenzoylhydrazone m. 151°–152° (corr.), by Sah and Hsü.⁴

Properties.—Stephan,⁵ who isolated *n*-decylaldehyde from sweet orange oil, Schimmel & Co.,⁶ who isolated this aldehyde from lemongrass oil, and Uhl⁷ reported these properties:

b ₇₅₅	207°–209° ⁵ (with slight decomposition)	d ₂₀	0.8502 ⁷
		n _D ²⁰	1.4287 ⁷
b ₁₂	93°–94° ⁵	n _D ¹⁵	1.42977 ⁵
b _{6.5}	80°–81° ⁶		

n-Decylaldehyde prepared synthetically usually has a lower specific gravity than that noted above (about 0.830 at 15°).

n-Decylaldehyde possesses a strong odor somewhat reminiscent of sweet orange oil. On oxidation with air or with potassium permanganate, *n*-decylaldehyde yields *n*-capric acid.

Use.—*n*-Decylaldehyde is used extensively but most sparingly as an adjunct in all kinds of perfume compositions. It is indispensable in imitation citrus oils, particularly orange.

¹ *J. Am. Chem. Soc.* **37** (1915), 2760.

² *J. Am. Pharm. Assocn.* **24** (1935), 381.

³ *J. Am. Chem. Soc.* **52** (1930), 2958.

⁴ *Rec. trav. chim.* **59** (1940), 349.

⁵ *J. prakt. Chem.* II, **62** (1900), 525.

⁶ *Ber. Schimmel & Co.* Oct. (1905), 43.

⁷ *J. Am. Pharm. Assocn.* **24** (1935), 381.

Lauraldehyde

 $C_{12}H_{24}O$

Mol. Weight 184.31

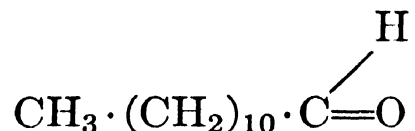
n-Dodecylaldehyde. Dodecanal

Occurrence.—Lauraldehyde has been observed in the oils of *Abies alba*, sweet orange, rue, and Okinawa pine.

Isolation.—Through the sodium bisulfite compound.

Identification.—By the preparation of derivatives:

- (1) Semicarbazone m. 105° – 105.5° , according to Naves.¹
- (2) *p*-Nitrophenylhydrazone m. 90° , according to Mannich and Nadelmann.²
- (3) 2,4-Dinitrophenylhydrazone m. 106° , according to Allen.³
- (4) Hydrazone from 1-methyl-3-carbohydrazidopyridinium *p*-toluene sulfonate m. 145° (corr.), by Allen and Gates.⁴

Properties.—Lauraldehyde, a solid at room temperature, possesses a very strong odor slightly reminiscent of pine needle and orange oils. The following properties have been reported by Zaar,⁵ Siegmund,⁶ Mannich and Nadelmann,⁷ and Naves:⁸

m.	44.5° ^{5, 8}	d_4^{20}	0.8319 ⁸
b.	227° – 235° ⁶	n_D^{20}	1.43704 ⁸
b_{11}	124° – 126° ⁷		
$b_{2.4}$	96° – 97° ⁸		

According to the last-named author, the aldehyde regenerated from the semicarbazone by oxalic hydrolysis melts at 11° , but gradually deposits Krafft's aldehyde m. 44.5° (see above).

On exposure to air, and more readily in the presence of traces of mineral acids, lauraldehyde polymerizes to a dimer. Mannich and Nadelmann⁹ reported that this dimer crystallizes from 50 parts of alcohol or 10 parts of ether, melting then at 57° . The dimer or polymer is very stable and does not depolymerize on heating, steam distilling, or by treatment with warm sulfuric acid. On oxidation lauraldehyde most readily yields lauric acid.

Use.—Lauraldehyde is used extensively but most sparingly as an adjunct in all kinds of perfume compositions of fancy and oriental character.

¹ *Perfumery Essential Oil Record* **38** (1947), 295.

² *Ber.* **63** (1930), 798.

³ *J. Am. Chem. Soc.* **52** (1930), 2958.

⁴ *J. Org. Chem.* **6** (1941), 599.

⁵ *J. prakt. Chem.* [2], **132** (1931), 169. Cf. Krafft, *Ber.* **13** (1880), 1414.

⁶ *Monatsh.* **52** (1929), 190.

⁷ *Ber.* **63** (1930), 798.

⁸ *Perfumery Essential Oil Record* **38** (1947), 295.

⁹ *Ber.* **63** (1930), 798.

Stearaldehyde

C₁₈H₃₆O

Mol. Weight 268.47

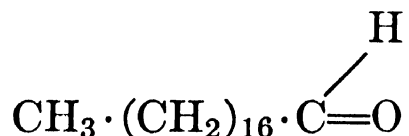
Stearic aldehyde. *n*-Octadecyl aldehyde. Octadecanal

Occurrence.—Stearaldehyde was found by Ikeda¹ in the volatile oil of *phachium* or *Cinnamomum micranthum* Hayata, a tree resembling camphor and growing in Formosa.

Isolation.—Through the sodium bisulfite compound m. 143° (with decomposition) which an ethereal solution of this aldehyde yields on shaking for a long time with a saturated aqueous solution of sodium bisulfite.

Identification.—Stearaldehyde can be identified by the preparation of several derivatives:

- (1) Semicarbazone m. 108°–109°, according to Stephen.²
- (2) *p*-Nitrophenylhydrazone m. 101° (from methyl alcohol), according to the same author.

Properties.—Stearaldehyde melts at 38° and readily polymerizes to a white solid m. 80°.

Oxidation with potassium permanganate in glacial acetic acid at 100° yields stearic acid.

Use.—Stearaldehyde is not used in our industries.

¹ *J. Chem. Soc. Japan* **51** (1930), 335.

² *J. Chem. Soc.* **127** (1925), 1876.

(b) UNSATURATED ALIPHATIC ALDEHYDES.

Artemisal

= Methacrolein

C₄H₇O

Mol. Weight 71.10

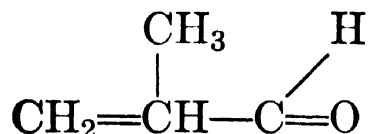

Adams and Oakberg¹ isolated from the volatile oil of *Artemisia tridentata typica* (black sage), fam. *Compositae*, a highly volatile aldehyde which was strongly lachrymatory and possessed the characteristic odor of sagebrush. They named this new aldehyde artemisal.

A few years later Kinney, Jackson, DeMytt and Harris² showed that the artemisal of Adams and Oakberg was in reality methacrolein. On fairly

rapid heating, the 2,4-dinitrophenylhydrazone melted at 206°–207° (with decomposition), on slow heating at 200°–201° (with decomposition).

¹ *J. Am. Chem. Soc.* **56** (1934), 457.

² *J. Org. Chem.* **6** (1941), 612.

2-Hexen-1-al

C₆H₁₀O

Mol. Weight 98.14

α , β -Hexylenaldehyde. β -Propylacrolein. "Leaf aldehyde"

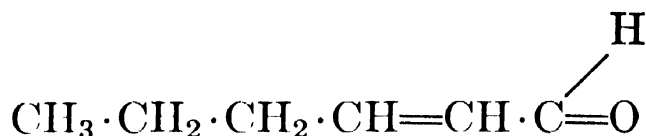

Occurrence.—This aldehyde was first identified by Curtius and Franzen ¹ in the oil distilled from the leaves of *Carpinus betulus* L. but was later detected by these same workers in the oils derived from green leaves of numerous plant species. Takei, Sakato and Ono ² likewise isolated a "leaf aldehyde" reported as 2-hexen-1-al from tea leaf, mulberry, acacia, and radish leaf oil; while Janistyn ³ somewhat later reported that the "leaf aldehyde" obtained by oxidation of *trans*-3-hexen-1-ol with chromic acid has been recognized in tea, ivy "Fallnetz," clover, oak, beech, wheat, robinia, mulberry, black radish, violet leaves, and cucumber. Recent work of Bohnsack ⁴ indicates the presence of 2-hexen-1-al in Java citronella oil. However, either the properties reported for the aldehyde or the operations described in its isolation raise some question as to whether or not all these authorities are dealing with the same isomer of hexenal.

Isolation.—In the case of isolation too, confusion exists, as Nye and Spoehr ⁵ maintain that the separation of "hexenal" from fresh leaves requires a pre-exposure to air for a period of time, while Takei, Sakato and Ono ⁶ favor the view that both the hexenols from which the aldehyde may arise, as well as the 2-hexenal *per se*, are present chiefly in fresh leaves, and require neither fermentation nor enzyme action for their isolation. These latter authors, however, obtained only 0.0007% yield, whereas Nye and Spoehr ⁷ report 0.04%. Here again it is quite possible that the workers dealt with isomeric aldehydes.

Acetone extraction ⁸ has been employed to obtain the α , β -hexylenaldehyde, but steam distillation seems to be the most convenient method for isolating the crude compound.

On treatment of the distillate with an alcoholic solution of *m*-nitro-benzoylhydrazine, this aldehyde forms a hydrazone m. 167°, from which the hexenal can be regenerated, according to Curtius and Franzen.⁹

Identification.—Theoretically, this unsaturated aldehyde may exist as *cis*- and *trans*-isomers, therefore different preparative methods could yield different forms of the same aldehyde, the derivatives of which possess variant properties. However, no proof has as yet been offered to show the identity of any of the following compounds and the divergence between properties of certain of these derivatives may be due to the existence of different geometric forms rather than formation from meta-isomers.

2-Hexen-1-al can be characterized by the preparation of several derivatives:

(1) Semicarbazone m. 172°–173°, according to Schimmel & Co.,¹⁰ von Braun and Rudolph,¹¹ and Takei et al.;¹² 175°–176° by Delaby and Guillot-Allègre.^{13, 14}

(2) *p*-Nitrophenylhydrazone m. 137° by Tsujimura,¹⁵ Takei et al.,¹⁶ Curtius and Franzen,¹⁷ and von Braun and Rudolph;¹⁸ 139° according to Delaby and Guillot-Allègre.¹⁹

(3) 2,4-Dinitrophenylhydrazone m. 196° from oil of green tea, according to Tsujimura.²⁰

However, Takei and collaborators²¹ prepared a leaf aldehyde by the oxidation of the natural 3-hexen-1-ol as isolated from fresh tea leaves. This aldehyde which boiled at 138°–140° yielded a 2,4-dinitrophenylhydrazone m. 144°, a semicarbazone m. 173°, and a *p*-nitrophenylhydrazone m. 137°. Moreover, Takei et al.²² had previously isolated this same "leaf aldehyde" which he described as 2-hexenal, from green leaves of several plants and identified it by the same derivatives as mentioned above, with like properties.

Two possibilities present themselves—either these hexenals, the 2,4-dinitrophenylhydrazones of which melt at 196° and 144°, are geometric forms; or a structural isomer may have been isolated, i.e., a β -hexenal, instead of the α -hexenal as assumed. However, there is not at hand sufficient evidence to demonstrate the full truth of either postulate.

Properties.—2-Hexen-1-al possesses a strong and pungent odor of green leaves. Curtius and Franzen²³ reported these properties for the natural isolates:

b ₁₇	47°–48°
d ₄ ^{17.9}	0.8470
d ₀	0.8684
n _D ^{17.9}	1.44602

2-Hexenal has been prepared synthetically by von Braun and Rudolph,²⁴ and Delaby and Guillot-Allègre^{25, 26} who found these characteristics:

	b	d	n _D	M.R.
b.	150°–152° ²⁵	d ₄ ²⁰ 0.8491 ²⁴	n _D ²¹ 1.4390 ²⁵	Obs. 30.40 ²⁶
b _{18.5}	49.5° ²⁶	d ₄ ¹³ 0.8610 ²⁶	n _D ¹⁸ 1.4462 ²⁴	Calc. 29.50 ²⁶
b ₁₂	43° ²⁴			

Takei et al.²⁷ reported a leaf aldehyde isolated from green tea oil as b. 138°–140°. The divergence of this boiling range from that of the synthetics cited above adds another point in favor of regarding this hexenal as isomeric with the products of von Braun,²⁸ Curtius and Franzen,²⁹ and Delaby and Guillot-Allègre,³⁰ etc.

β -Propylacrolein has been observed by Delaby and Guillot-Allègre³¹ to possess a certain degree of lachrymatory action. It does not polymerize readily but is slowly oxidized by air. With alkaline silver oxide, 2-hexenal is oxidized to 2-hexenoic acid m. 33°. In the preparation of this type of de-

rivative, however, the worker should consider the lability of the ethylenic linkage,³² as well as the fact that its presence here may result in geometric isomers.³³

Use.—Leaf aldehyde is used for imparting to perfume and flavor compositions a characteristic odor of green leaves where such a note is desired.

- ¹ *Liebigs Ann.* **390** (1912), 89; **404** (1914), 101. Cf. *Chem. Zentr.* I (1911), 1142; II (1912), 39, 523, 722. Meyer, *Chem. Zentr.* I (1918), 637.
- ² *Sci. Papers Inst. Phys. Chem. Research (Tokyo)* **23**, Nos. 482–7 (1934). *Chem. Abstracts* **28** (1934), 3178.
- ³ *Seifensieder-Ztg.* **67** (1940), 1625.
- ⁴ *Ber.* **76B** (1943), 564.
- ⁵ *Arch. Biochem.* **2** (1943), 23.
- ⁶ *Sci. Papers Inst. Phys. Chem. Research (Tokyo)* **23**, Nos. 482–7 (1934). *Chem. Abstracts* **28** (1934), 3178.
- ⁷ *Arch. Biochem.* **2** (1943), 23.
- ⁸ Tsujimura, *Sci. Papers Inst. Phys. Chem. Research (Tokyo)* **34** (1938), 406. *Chem. Abstracts* **32** (1928), 8029.
- ⁹ *Liebigs Ann.* **390** (1912), 89; **404** (1914), 101. Cf. *Chem. Zentr.* I (1911), 1142; II (1912), 39, 523, 722. Meyer, *Chem. Zentr.* I (1918), 637.
- ¹⁰ *Ber. Schimmel & Co.* (1918), 41.
- ¹¹ *Ber.* **67B** (1934), 269.
- ¹² *Sci. Papers Inst. Phys. Chem. Research (Tokyo)* **23**, Nos. 482–7 (1934). *Chem. Abstracts* **28** (1934), 3178.
- ¹³ *Compt. rend.* **192** (1931), 1467.
- ¹⁴ *Bull. soc. chim.* [4], **53** (1933), 310.
- ¹⁵ *Sci. Papers Inst. Phys. Chem. Research (Tokyo)* **34** (1938), 406. *Chem. Abstracts* **32** (1938), 8029.
- ¹⁶ *Sci. Papers Inst. Phys. Chem. Research (Tokyo)* **23**, Nos. 482–7 (1934). *Chem. Abstracts* **28** (1934), 3178.
- ¹⁷ *Liebigs Ann.* **390** (1912), 98.
- ¹⁸ *Ber.* **67B** (1934), 269.
- ¹⁹ *Compt. rend.* **192** (1931), 1467. *Bull. soc. chim.* [4], **53** (1933), 301.
- ²⁰ *Sci. Papers Inst. Phys. Chem. Research (Tokyo)* **34** (1938), 406. *Chem. Abstracts* **32** (1938), 8029.
- ²¹ *J. Agr. Chem. Soc. Japan* **14** (1938), 709. *Chem. Abstracts* **33** (1939), 2557.
- ²² *Sci. Papers Inst. Phys. Chem. Research (Tokyo)* **23**, Nos. 482–8 (1934). *Chem. Abstracts* **28** (1934), 3178.
- ²³ *Liebigs Ann.* **390** (1912), 98.
- ²⁴ *Ber.* **67B** (1934), 269.
- ²⁵ *Compt. rend.* **192** (1931), 1467.
- ²⁶ *Bull. soc. chim.* [4], **53** (1933), 310.
- ²⁷ *Sci. Papers Inst. Phys. Chem. Research (Tokyo)* **23**, Nos. 482–7 (1934). *Chem. Abstracts* **28** (1934), 3178.
- ²⁸ *Ber.* **67B** (1934), 269.
- ²⁹ *Liebigs Ann.* **390** (1912), 89.
- ³⁰ *Compt. rend.* **192** (1931), 1467. *Bull. soc. chim.* [4], **53** (1933), 301.
- ³¹ *Ibid.*
- ³² Linstead et al., *J. Chem. Soc.* (1930), 1603; (1934), 614.
- ³³ Delaby and Guillot-Allègre, *Bull. soc. chim.* [4], **53** (1933), 314.

2,6-Nonadien-1-al

"Violet Leaf Aldehyde"

C₉H₁₄O

Mol. Weight 138.20

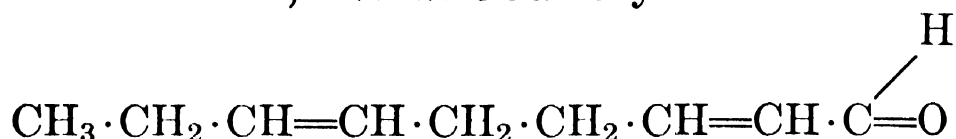
 α,ϵ -Nonadien aldehyde

Occurrence.—The oil derived from violet leaves by extraction with volatile solvents and by steam distillation of the concentrated extract was first investigated by von Soden,¹ and by Treff et al.² Somewhat later Walbaum and Rosenthal³ isolated from it an aldehyde C₉H₁₄O which they named violet leaf aldehyde because of its characteristic odor of violet leaves. The work of Späth and Keszler,⁴ and of Ruzicka and Schinz⁵ established violet leaf aldehyde as 2,6-nonadienal and showed that about one-third of the ethereal violet leaf oil consists of this aldehyde. The latter authors succeeded in preparing a 2,6-nonadienal from synthetic 3-hexen-1-ol. Ruzicka⁶ also found that the ethereal oil derived from violet leaves contains about ten times more of this aldehyde than the corresponding oil derived from violet flowers.

Later Ruzicka, Schinz and Susz⁷ suggested that the 2,6-nonadienal occurring naturally in violet leaves has probably the 2(*trans*)-, 6(*cis*)- form, whereas the synthetic 2,6-nonadienal as obtained from synthetic 3-hexen-1-ol has possibly the *trans, trans*- form of the corresponding alcohol.

Takei and Ono,⁸ and Janistyn⁹ recognized the existence of a 2,6-nonadienal in the ethereal oil of cucumber, but the identity of this isomer with that identified in violet leaf oil has not been confirmed, according to Schimmel & Co.¹⁰

Isolation.—Ruzicka and Schinz¹¹ isolated the natural 2,6-nonadienal from the fraction of the ethereal violet leaf oil, b₁₂ below 105°, by hydrolyzing the semicarbazone m. 157°–158° with a 15% sulfuric acid solution and by steam distillation, the yield of pure aldehyde from the semicarbazone being 18%.

Identification.—Ruzicka, Schinz and Susz¹² identified natural 2,6-nonadienal from violet leaves by the preparation of these derivatives:

- (a) Semicarbazone m. 156°–158°.
- (b) Phenylsemicarbazone m. 99°–100°.
- (c) *p*-Nitrophenylhydrazone m. 95°–97°.
- (d) Aminoguanidine picrate m. 189°–190°.

The natural isolate from cucumbers of Takei and Ono¹³ yielded a semicarbazone m. 157.5° and a 2,4-dinitrophenylhydrazone m. 113°.

Synthetic 2,6-nonadienals prepared by Ruzicka and co-workers were reported at one time not to yield solid derivatives¹⁴ with *p*-nitrophenylhydrazine, aminoguanidine or phenylsemicarbazide. However, in a later publication¹⁵ these authors reported the

aminoguanidine picrate of the synthetic as m. 190°–192°. The semicarbazones of the synthetic and natural aldehydes melt at the same temperature.

Properties.—Purifying natural 2,6-nonadienal through its semicarbazone, Ruzicka and collaborators¹⁶ found the following properties:

b_{12}	89°–90°	d_4^{24}	0.8658
d_4^{27}	0.8632	n_D^{24}	1.4700
		EM_D	+1.66

The same authors reported for synthetic pure 2,6-nonadienal:

b_{11}	85°–87°	n_D^{20}	1.4660
d_4^{20}	0.8678	EM_D	+1.20

Semicarbazone m. 155°–157°

2,6-Nonadienal possesses the penetrating characteristic odor of violet leaves to a high degree.

Use.—Synthetic 2,6-nonadienal is used to great advantage in high-grade perfume compositions where the odor of violet leaves is desired.

¹ *J. prakt. Chem.* [2], **110** (1925), 273.

² *Ibid.* **113** (1926), 357.

³ *Ber. Schimmel & Co., Jubiläums Ausgabe* (1929), 211.

⁴ *Ber.* **67B** (1934), 1496.

⁵ *Helv. Chim. Acta* **17** (1934), 1592; **18** (1935), 381.

⁶ *Perfumery Essential Oil Record* **29** (1938), 174. Ruzicka and Schinz, *Helv. Chim. Acta* **25** (1942), 760.

⁷ *Helv. Chim. Acta* **27** (1944), 1561. *Chem. Abstracts* **39** (1945), 3117.

⁸ *J. Agr. Chem. Soc. Japan* **15** (1939), 193. *Chem. Abstracts* **33** (1939), 6524.

⁹ *Seifensieder-Ztg.* **67** (1940), 16.

¹⁰ *Ber. Schimmel & Co.* (1939), 159.

¹¹ *Helv. Chim. Acta* **17** (1934), 1592.

¹² *Ibid.* **27** (1944), 1561. *Chem. Abstracts* **39** (1945), 3117.

¹³ *J. Agr. Chem. Soc. Japan* **15** (1939), 193. *Chem. Abstracts* **33** (1939), 6524.

¹⁴ *Helv. Chim. Acta* **17** (1934), 1602.

¹⁵ *Ibid.* **27** (1944), 1561. *Chem. Abstracts* **39** (1945), 3117.

¹⁶ *Ibid.* **17** (1934), 1598; **27** (1944), 1561. *Chem. Abstracts* **39** (1945), 3117.

SUGGESTED ADDITIONAL LITERATURE

Sebastien Sabetay, "Progress in the Field of the Chemistry of the Aromatics for 1934," *Riechstoff Ind. Kosmetik* **11** (1936), 94.

n-2-Decen-1-alC₁₀H₁₈O

Mol. Weight 154.24

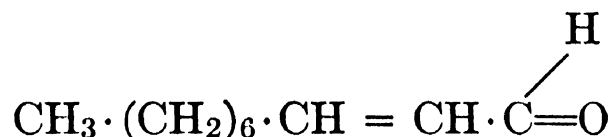
n-1-Decenaldehyde. *n*-1-Decylenic aldehyde.

Occurrence.—*n*-2-Decen-1-al was first observed by van Romburgh¹ in the essential oil derived from the leaves, petioles and rhizomes of *Achasma Walang* Val. (which occurs in Java). Later Carlblom² found it in the volatile oil distilled from *Coriandrum sativum* during the flowering state. More recently Naves³ has observed it in sweet orange oil from French Guinea. Investigating the aldehydic components of this oil, Naves⁴ arrived at the conclusion that they consist of:

31%	<i>n</i> -octanal
27%	<i>n</i> -decanal
7.5%	citral
6%	<i>n</i> -dodecanal
4%	2-decen-1-al
3%	2-dodecen-1-al

Isolation.—The various workers mentioned above observed that *n*-2-decen-1-al cannot be isolated by means of its bisulfite or sulfite addition compound, as only a small percentage of the aldehyde can be regenerated by treatment with sodium carbonate or acids. As a matter of fact, the presence of *n*-2-decen-1-al in sweet orange oil, according to Naves,⁵ explains, at least partly, the loss in aldehydes experienced during treatment of the oil with sulfite reagents, the aldehydes of that type (cf. "*n*-2-Dodecen-1-al") being almost entirely lost under these circumstances.

Neither can these particular aldehydes be regenerated from their semicarbazones by means of oxalic, phthalic or mineral acids, because resinification will take place.

The most effective method of isolating these aldehydes from an essential oil, therefore, is distillation *in vacuo*. Naves⁶ used the fraction b_{2.5} 80°–102° of sweet orange oil, while van Romburgh⁷ found that *n*-2-decen-1-al occurs in the fraction b₁₃ 104° of oil of *Achasma Walang* Val.

Identification.—By preparation of the semicarbazone m. 162°, and by oxidative means (see below).

Properties.—Van Romburgh⁸ reported these properties for *n*-2-decen-1-al:

b.	229°–231°	d ₁₅ ¹⁹	0.846
b ₁₃	104°	n _D ¹⁹	1.4538

Oxidation with a 4 per cent alkaline (potassium carbonate) solution of potassium permanganate yielded caprylic acid (*n*-octoic acid) m. 13.5°, b. 234°; amide m. 50° (van Romburgh).

Oxidation in a steady current of oxygen gave decenoic acid m. 12°, b₁₅ 165°; amide m. 121° (van Romburgh).

Catalytic hydrogenation of *n*-2-decen-1-al with platinum black in neutral ethyl acetate yielded decanol b. 228°–231° which was identified by preparation of its α -naphthylurethane m. 70° (van Romburgh).

Use.—The synthetic product probably could be used for compounding imitation orange oils, but nothing has been published in the literature to this effect.

¹ *Proc. Acad. Sci. Amsterdam* **32**, II (1929), 1352. *Rec. trav. chim.* **57** (1938), 494.

² *J. prakt. Chem.* **144** (1936), 225.

³ *Perfumery Essential Oil Record* **38** (1947), 295.

⁴ *Ibid.*

⁵ *Ibid.*

⁶ *Ibid.*

⁷ *Proc. Acad. Sci. Amsterdam* **32**, II (1929), 1352. *Rec. trav. chim.* **57** (1938), 494.

⁸ *Ibid.*

n-2-Dodecen-1-al

C₁₂H₂₂O

Mol. Weight 182.30

n-1-Dodecenaldehyde. *n*-1-Dodecylenic aldehyde.

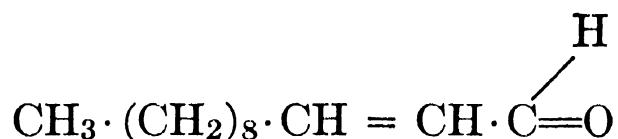

Occurrence.—Observed by Koolhaas¹ as main constituent of the volatile oil derived from the leaves of *Eryngium foetidum* L. (which in Java constitutes an edible vegetable).

Isolation.—By fractional distillation *in vacuo*, the fractions b₈ 83°–150° containing the aldehyde. *n*-2-Dodecen-1-al cannot be regenerated from its bisulfite or sulfite addition compound, nor from its semicarbazone (cf. “*n*-2-Decen-1-al”).

Identification.—By preparation of the semicarbazone m. 158°.

Properties.—Koolhaas² reported the following properties for certain fractions of oil of *Eryngium foetidum* which consisted chiefly of *n*-2-dodecen-1-al:

b ₈	120°–125°	b ₈	125°–130°
d ₄ ²⁶	0.8497	d ₄ ²⁶	0.8465
n _D ²⁶	1.4567	n _D ²⁶	1.4550
		b ₉	149°–156°
		d ₂₄	0.8749

Oxidation of *n*-2-dodecen-1-al with a 4 per cent potassium permanganate (alkaline) solution yielded capric acid which was identified by preparation of its anilide m. 63° (Koolhaas).

Oxidation with silver oxide in alkaline solution or with air oxygen gave 1-undecene-1-carboxylic acid m. 15.8°–16.8°; amide m. 114° (Koolhaas).

On exposure to air, *n*-2-dodecen-1-al readily oxidizes to the above-mentioned 1-undecene-1-carboxylic acid.

Use.—This aldehyde is not used in our industries.

¹ *Rec. trav. chim.* **51** (1932), 460.

² *Ibid.*

(c) ALIPHATIC TERPENE ALDEHYDES.

Citral

C₁₀H₁₆O

Mol. Weight 152.23

In this treatise no purpose would be served by a review of the prolonged controversy between Barbier and collaborators, and Tiemann, Semmler and their school on the other side, regarding the structure of this important open-chained, unsaturated terpene aldehyde. For details the reader is referred to Simonsen's "The Terpenes," Vol. I. Citral, as it occurs in nature, is today regarded as a mixture of at least two, and probably four, isomers. Historically these two components were known as citral *a* and citral *b* or geranial and neral, terms that still commonly apply to them. Physicochemical evidence has been gathered to show that these components are related as geometric isomers of a diolefinic aldehyde. At the same time studies supported the view that these geometric isomers, geranial and neral or citral *a* and citral *b*, were not homogeneous but are themselves each composed of two structural isomers differing from one another only by relative position of the double bond on the terminal carbon atoms.

Citral a (Geranial). Cis- Isomer

3,7-Dimethyl-2,7-octadien-1-al

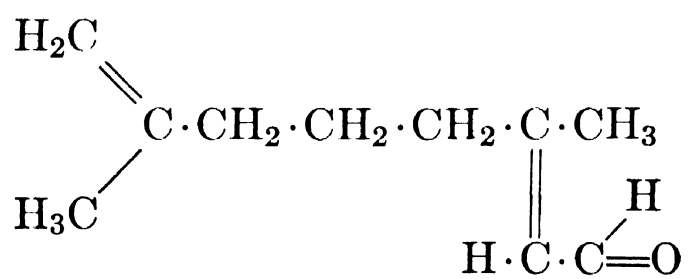

and

3,7-Dimethyl-2,6-octadien-1-al

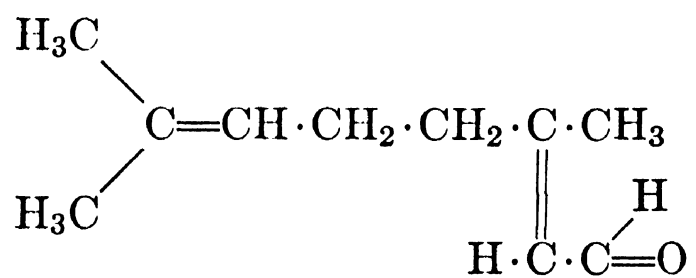

Citral b (Neral). Trans- Isomer

3,7-Dimethyl-2,7-octadien-1-al

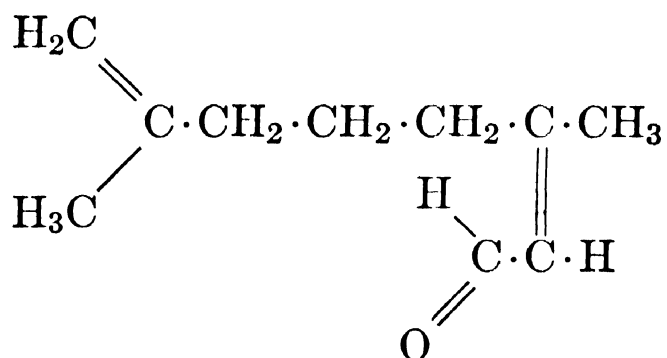

and

3,7-Dimethyl-2,6-octadien-1-al

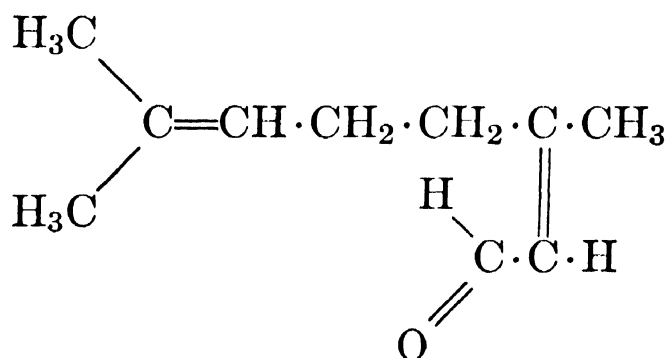

In the following, the general term citral, unless specified otherwise, will always refer to the natural aldehyde, a mixture of citral *a* and *b* in which the “*a*” form largely predominates.

Occurrence.—Citral occurs in numerous essential oils, in some as the principal constituent. Thus, citral is present in oil of lemongrass (70–80 per cent), *Backhousia citriodora*, *Ocimum pilosum* (about 35 per cent), *Monarda citriodora*, verbena, *Eucalyptus staigeriana*, *Leptospermum citratum*, citronella Java type, lemon, lime, ginger root, in the leaf oils of several citrus species, etc.

Isolation.—According to Tiemann and Semmler,¹ and Tiemann,² the citral-containing oil—lemongrass oil, for example—is shaken with sodium bisulfite solution. The resulting crystalline reaction product may be purified by washing with alcohol and ether. The citral can be regenerated in pure form by decomposing the sodium bisulfite compound with soda and by distilling the citral *in vacuo*. Tiemann found that citral *a* can be obtained free from citral *b*, during the regeneration from the bisulfite compound, by taking advantage of the fact that the crystalline sodium bisulfite compound of citral *a* is sparingly soluble, the corresponding compound of citral *b* readily soluble. Thus citral *a* may be isolated from regular citral by converting the latter into the normal sodium bisulfite compound $\text{C}_9\text{H}_{15}\text{CH}(\text{OH})\text{SO}_3\text{Na}$, by suspending this compound in water, by covering the mixture with ether, and by partially decomposing the compound with soda in the cold. Hibbert and Cannon³ indicated optimum conditions for the separation of citral *a* and *b* by Tiemann’s method. Citral *b*, according to Tiemann,⁴ can be isolated from regular citral by shaking it for a short time with alkaline cyanacetic acid solution; citral *a* reacts with this acid much more readily than citral *b*.

Due to the presence of two ethylenic linkages and an aldehydic group, the reaction between citral and sodium bisulfite is even more complex than that between citronellal and sodium bisulfite. The reaction was studied in detail by Tiemann and collaborators.

The normal bisulfite compound

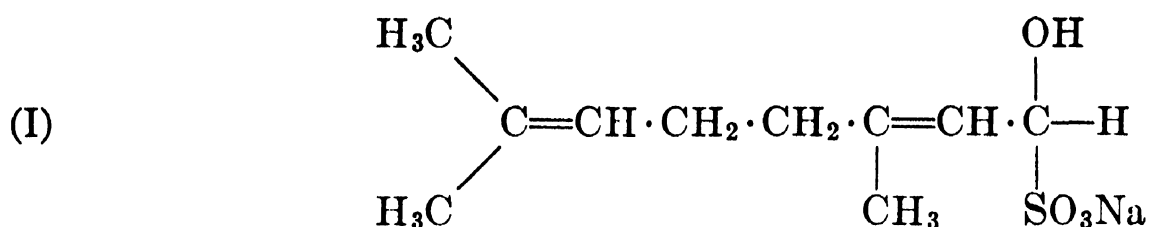

is formed quantitatively when citral is shaken with a sodium bisulfite solution containing some free acetic acid and not too much free sulfurous acid. The bisulfite solution is prepared by adding a solution of crystalline sodium sulfite to a little more than one molecular proportion of acetic acid. After shaking, the normal crystalline double compound $\text{C}_9\text{H}_{15} \cdot \text{CH}(\text{OH}) \cdot \text{SO}_3\text{Na}$ (I) separates. It is almost insoluble at low temperature and can be recrystallized from a solution of sodium bisulfite or from methyl alcohol containing some free acetic acid. This normal bisulfite compound is quite easily decomposed but citral cannot be regenerated quantitatively with sodium carbonate or sodium hydroxide, the decomposition always being connected with a loss of 10–15% citral which may be due to the formation of cyclic bisulfite compounds.

If the normal bisulfite compound (I) is slightly warmed for several hours with an excess of sodium bisulfite and the solution kept acidic, a *labile* compound (II) containing 2 mols of sodium bisulfite will be formed in quantitative yield. The crystalline sodium salt of the dihydrodisulfonic compound (II) is very hygroscopic; it reacts with phenylhydrazine and, therefore, contains a free aldehydic group.

Citral can be regenerated from this labile dihydrodisulfonic derivative

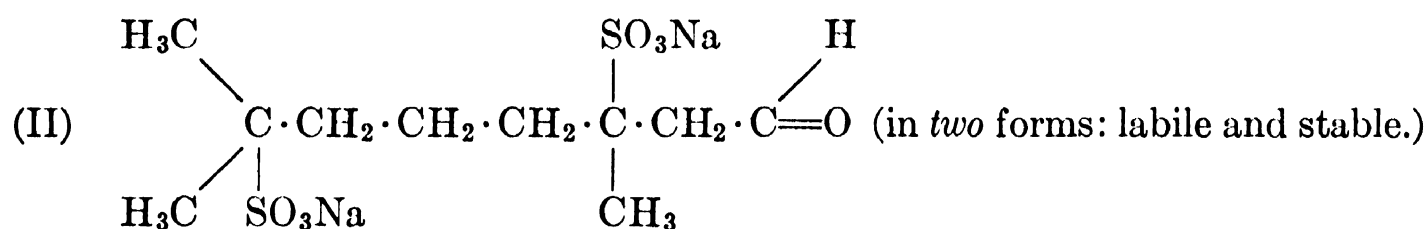
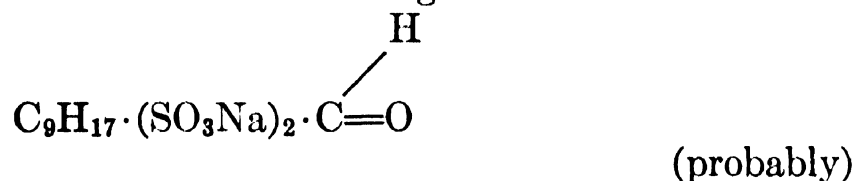

with alkali hydroxide, but no longer with alkali carbonate. If, during the dissolving of the normal bisulfite compound (I), the temperature rises too high, the *labile* dihydrodisulfonic compound (II) is converted into a *stable* dihydrodisulfonic compound (also II), from which citral, even with alkali hydroxide, can no longer be regenerated. The same *stable* dihydrodisulfonic compound (II) will be obtained also if the normal bisulfite compound (I) is dispersed in water and steam distilled for some time, or digested with chloroform.

If a solution of the *labile* citraldihydrodisulfonate (II) is shaken with citral, the aldehyde is taken up under formation of citralhydromonosodium sulfonate

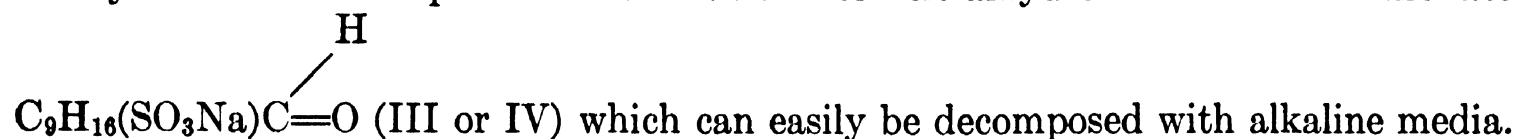

Having discussed so far the reactions between citral and sodium bisulfite, we shall now review the action of neutral sodium sulfite upon this aldehyde.

The *labile* dihydrodisulfonic sodium salt of citral (II) will be obtained also if citral is shaken with a solution of neutral sodium sulfite.

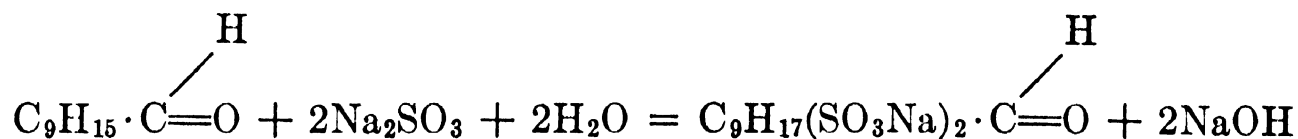

The alkali hydroxide being liberated in this reaction would decompose the dihydrodisulfonic compound while being formed; therefore, the solution must be kept only slightly alkaline by the continuous addition of dilute acetic acid, sulfuric acid, or an acid salt such as sodium bisulfite, sodium bicarbonate, etc. Neither must the solution be permitted to turn acid, as this would result in the formation of a *stable* dihydrodisulfonic compound (II) from which citral can no longer be regenerated. For this purpose, Tiemann⁵ suggested the following method:

Shake a solution of 350 g. of sodium sulfite, $\text{Na}_2\text{SO}_3 + 7\text{H}_2\text{O}$, in 1 liter of water (colored red with a little phenolphthalein solution) with 100 g. of pure citral. Reduce the strongly alkaline reaction to be produced, from time to time, by gradually adding standardized sulfuric acid of about 20% strength. Keep the solution always slightly alkaline as revealed by the red color of the indicator.

The *labile* dihydrodisulfonic compound (II) obtained by the action of neutral sodium sulfite upon citral can be purified by crystallization from methyl alcohol. It yields a semicarbazone as it contains a free aldehydic group. By the action of acids the *labile* form (II), as said, can be converted into a *stable* form. When shaken with dilute alkali, the latter compound yields a monoderivative (III or IV) containing a free aldehydic group:

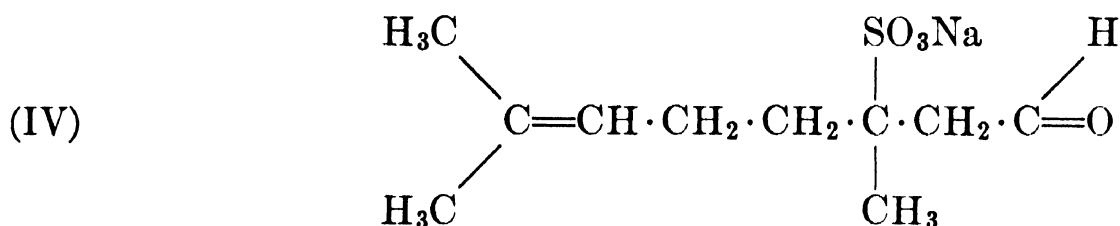
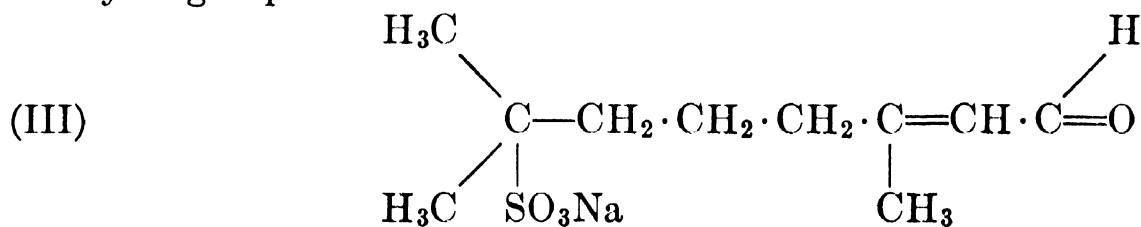

For further details regarding the bisulfite compounds of citral, see the paper by Dodge⁶ "Citral and Its Sulfonates."

Quantitative Determination.—See Vol. I, Chapter 4, "The Examination and Analysis of Essential Oils, Synthetics, and Isolates," p. 279.

Identification.—Citral can quite readily be identified by the preparation of several derivatives. Since natural citral consists predominantly of citral *a*, the derivatives of this modification are usually obtained easier and in purer form.

(1) By the semicarbazones m. 164° and 171°. Gildemeister and Hoffmann⁷ suggest adding a solution of four parts of semicarbazide hydrochloride in a little water to a solution of 5 parts citral (or of the fraction to be examined) in 30 parts glacial acetic acid. After a short time, substantial quantities of semicarbazone will separate in needle form. Repeated recrystallization of these needles from methyl alcohol will give a sharp melting point of 164° (semicarbazone of citral *a*). The mother liquor separated from these needles by filtration contains the semicarbazone of citral *b* which can be obtained in leaflets m. 171°. Mixtures of the two semicarbazones show

melting points ranging from 130° to 171°. The two semicarbazones, according to Barbier,⁸ are derived from two isomeric aldehydes (citral *a* and citral *b*), and do not represent syn- anti-isomers.

(2) By the condensation products formed between citral and cyanacetic acid.

a-citrylidencyanacetic acid m. 122°.

b-citrylidencyanacetic acid m. 94°–95°.

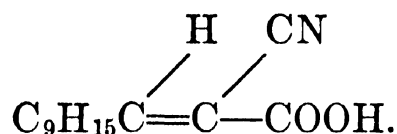

In order to prepare these compounds, Tiemann⁹ suggested adding 2 mols of sodium hydroxide (30% sodium hydroxide solution) and 1 mol of citral to a solution of 1 mol cyanacetic acid in about 3 times its weight of water. If pure, the citral will dissolve completely on shaking. The citrylidencyanacetic acid can be precipitated with acids from the clear solution or from the solution purified by shaking with ether, in the form of crystals or as oil which will soon congeal. After dissolving in benzene and precipitating with petroleum ether, the citrylidencyanacetic acid can be obtained in the form of coarse yellow crystals.

Since citral *b* combines with cyanacetic acid more slowly than citral *a*, this method may serve for the separation of citral *a* and citral *b*.

(3) By the preparation of *a*- or *b*-citryl- β -naphthocinchoninic acid m. 200°–201° as obtained by the condensation of citral with β -naphthylamine in the presence of pyruvic acid. Both citral *a* and citral *b* yield the same compound.

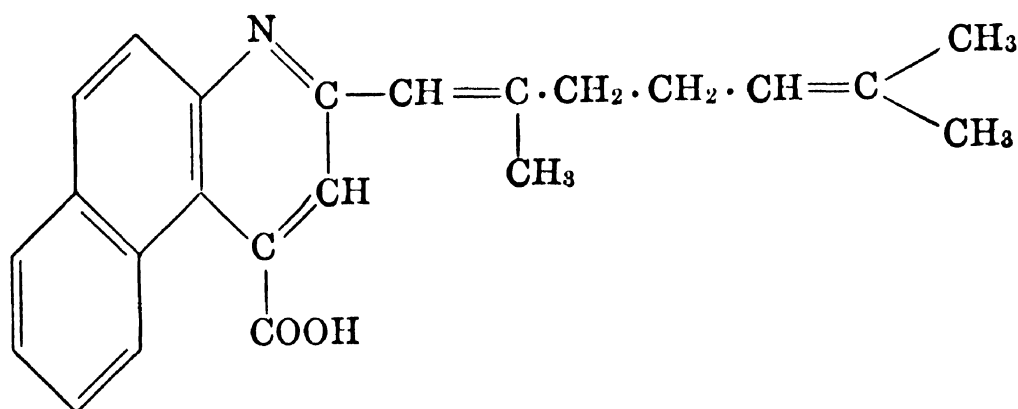

For this purpose, Doebner¹⁰ recommended dissolving 12 g. of pyruvic acid and 20 g. of citral (or the corresponding oil) in absolute alcohol. Twenty g. of β -naphthylamine, also dissolved in absolute alcohol, are added to this solution. The mixture is then refluxed for 3 hr. on a steam bath. On cooling, the citrylnaphthocinchoninic acid will separate in crystalline form; it is filtered off and purified by washing with ether. In case the acid should not be sufficiently pure, it is dissolved in ammonia and precipitated from the filtered solution by neutralizing with acetic acid. The substance thus purified crystallizes from alcohol in the form of yellow leaflets. Doebner reported a melting point of 197°. However, it is usually higher, sometimes even slightly above 200°.

When examining an oil for the presence of citral by Doebner's method, it should be kept in mind that other aldehydes too—citronellal, for example—yield derivatives of naphthocinchoninic acid. Furthermore, if the content of citral, or aldehydes in general, is low, a part of the employed pyruvic acid may be decomposed to acetaldehyde which will form α -methyl- β -naphthocinchoninic acid m. 310°. This is more sparingly soluble in alcohol than the corresponding citral compound and remains in the residue when the crude naphthocinchoninic acid is boiled with alcohol.

(4) By the preparation of the thiosemicarbazone m. 107° – 108° , and the semioxamazone m. 190° – 191° .

(5) According to Strain ¹¹ identification may be made by the 3-nitrobenzohydrazone m. 100° – 101° ; according to Whitmore, Revukas and Smith ¹² by the nitroguanylhyazone of citral m. 135° – 136.5° .

(6) The 2,4-dinitrophenylhydrazone has been variously reported by several investigators. As citral *a* as well as citral *b* may yield both α - and β - forms of this derivative, it is not surprising that several compounds should be obtained, but their correspondence to a particular formula still remains in question. Allen ¹³ reported two dinitrophenylhydrazones from citral, I m. 108° – 110° , II m. 96° , whereas Takei, Sakato and Ono ¹⁴ obtained a product from the citral derived from green tea oil m. 119° – 120° , and Roduta and Quibilan ¹⁵ reported still another m. 103° .

Citral can thus be identified quite easily by various methods; care, however, must be exercised in case citronellal is also present. Repeated recrystallization of the derivatives may be required.

Properties.—Citral is a slightly yellowish, optically inactive, liquid possessing a characteristic and powerful lemon-like odor and flavor. When boiling under atmospheric pressure, citral decomposes to a certain degree.

Tiemann and Semmler ¹⁶ reported the following properties:

b.	228° – 229°	d_{22}	0.8844
b_{23}	120° – 122°	d_{15}	0.8972
b_{20}	117° – 119°	n_D	1.48611 and 1.4931
b_{12}	110° – 112°		

When purified by the bisulfite compound, citral, according to Gildemeister and Hoffmann,¹⁷ had these properties:

Citral from Lemongrass Oil

b_{12}	110° – 111°
d_{15}^{15}	0.893
n_D^{17}	1.49015

Citral from Lemon Oil

b_5	92° – 93°
d_{15}^{15}	0.8926
n_D^{20}	1.48853

Gildemeister and Hoffmann ¹⁸ recorded for commercial citral:

d_{15}^{15}	0.892–0.895
n_D^{20}	1.482–1.489
Sol.	Soluble in 5 to 7 vol. of 60% alcohol

On a technical scale, citral is isolated from lemongrass oil by preparing the bisulfite compound and by decomposing it with soda.

Regarding citral *a* and citral *b*, the former is obtained free from citral *b* by regeneration from its sparingly soluble crystalline sodium bisulfite compound, the corresponding citral *b* compound being more readily soluble. Citral *b*, on the other hand, can be freed of citral *a* through the greater reactivity of citral *a* with cyanacetic acid.

Tiemann,¹⁹ and von Auwers and Eisenlohr²⁰ reported the following properties for the two forms:

Citral a

b_{20}	118°–119° ^{19, 20}	d_{20}	0.8898 ^{19, 20}
b_{12}	110°–112° ¹⁹	n_D^{20}	1.4891 ^{19, 20}

Citral b

b_{20}	117°–118° ^{19, 20}	n_D	1.49001 ¹⁹
b_{12}	102°–104° (uncorr.) ¹⁹	n_D^{20}	1.4891 ^{19, 20}
d_{20}	0.8888 ^{19, 20}		

Due to the conjugation of the ethylenic linkages, both aldehydes show a marked exaltation in their molecular refraction.

Owing to the presence of one aldehydic and two ethylenic linkages, citral is very readily attacked by oxidizing agents. Even on exposure to air, citral oxidizes quite easily, whereby its yellow color is intensified. Under the influence of weak oxidizing agents—for example, ammoniacal silver oxide—geranic acid $C_{10}H_{16}O_2$ is formed. This liquid acid possesses an odor reminiscent of higher fatty acids. The action of stronger oxidizing agents such as chromic acid yields geranic acid, methyl heptenone and methyl heptenone carboxylic acid. Further treatment with potassium permanganate—chromic acid mixture oxidizes methyl heptenone to acetone and laevulinic acid.

Hydrogenation, according to conditions, yields geraniol, or citronellal and citronellol, etc. Under the influence of acids or acid media, citral readily undergoes cyclization. For the same reason, hydrohalides of citral have not been observed. When treated with dilute sulfuric acid, or potassium bisulfate, citral is converted into *p*-cymene, with loss of water. Alkalies, too, attack citral; for example, when boiled with potassium carbonate solution, citral is decomposed into acetaldehyde and methyl heptenone.

When digesting citral with acetic anhydride and sodium acetate, Semmler and Schlossberger²¹ obtained the acetate of the enolic form of the aldehyde.

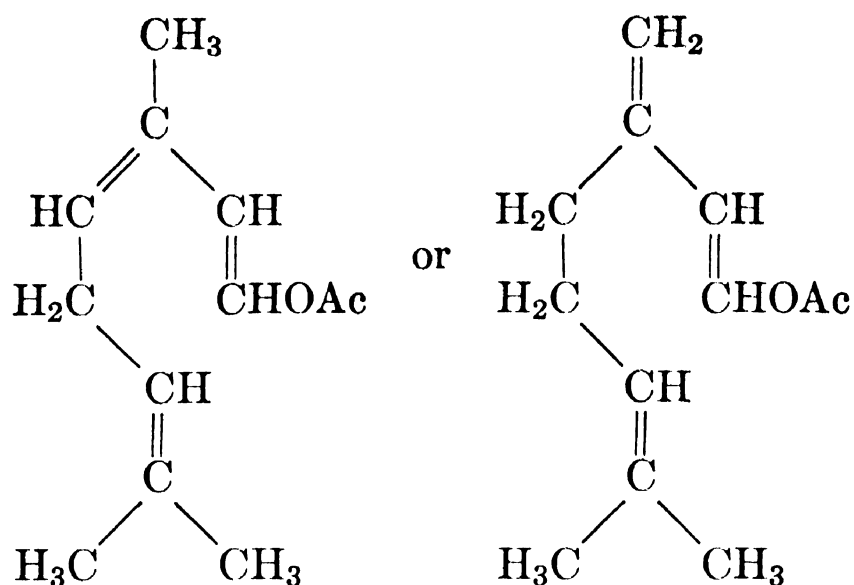

This acetate is a mobile oil b_{10} 118°–126°, d_{15} 0.943, and saponification number 291, with an odor resembling geranyl acetate.²² The enolic acetate cannot be hydrolyzed to regenerate the same aldehyde but yields isocitral.

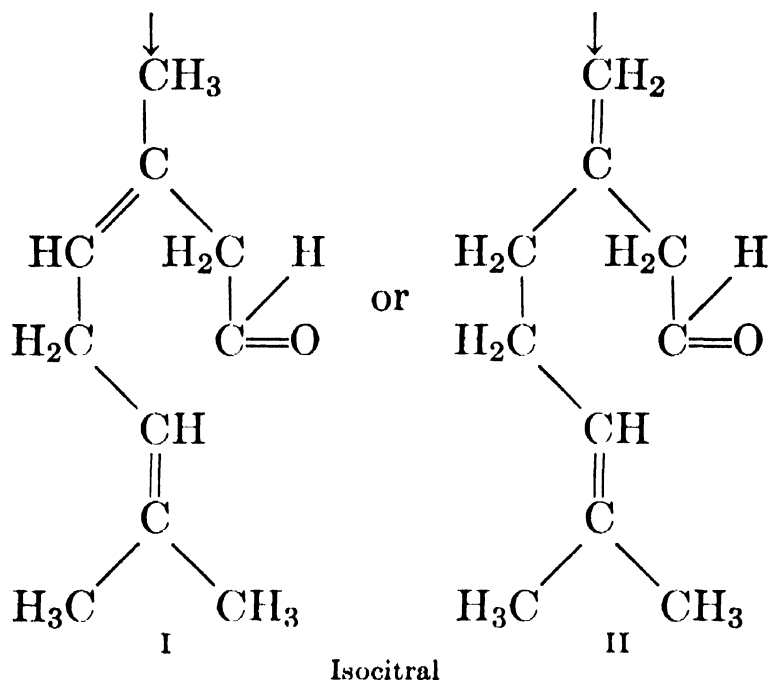

I is the more probable structural formula of isocitral because, analogous to citral *a* and citral *b*, it can occur in two diastereoisomeric forms (isomers of the ethylenic linkage).

Studying this reaction more thoroughly and starting from common citral, Schmidt²³ obtained a citral-enol acetate (yield 70 per cent, d_{15}^{15} 0.943, saponification number 291 = 101 per cent ester) which on gentle boiling with absolute methyl alcohol and aluminum isopropylate for 14 hr. yielded isocitral (yield 30 per cent, calculated upon the enol acetate used).

Isocitral is a mobile, slightly yellow, optically inactive oil, with a very fine, mild and fresh lemon odor, quite different from that of common citral (from lemongrass oil). The physical properties of isocitral differ little from those of regular citral, but the chemical behavior of isocitral and citral shows marked differences. Isocitral does not react with sodium sulfite bicarbonate; it forms a semicarbazone *m.* 140° from which the isocitral cannot be regenerated completely, even by treatment with oxalic or phthalic acid. Con-

trary to citral *a* and citral *b*, isocitral does not form a crystalline condensation product with cyanacetic acid. When treated with pyruvic acid and β -naphthylamine, isocitral yields a naphthocinchonic acid compound m. 195°–196°. Isocitral is much more sensitive than citral; it polymerizes under the prolonged influence of aluminum isopropylate; it tends toward cyclization, resinification, and conversion into *p*-cymene, even without treatment with sulfuric acid or condensing agents. According to Strausz,²⁴ cyclization and conversion into *p*-cymene may be caused even by the presence of about 1 per cent of fatty acids (acetic acid, *n*-acid C₈, C₉, C₁₀, C₁₂) and proceeds via 1-methyl-4-isopropylidene-cyclohexen-3-ol. Such acids are formed on air oxidation in poorly stored lemon oils from the corresponding aldehydes, while free acetic acid may originate by hydrolysis of linalyl acetate and geranyl acetate which occur in lemon oil. Poorly stored, spoiled, and oxidized lemon oils display the characteristic odor of *p*-cymene, while the odor of aged and air oxidized lemongrass oil does not reveal the presence of *p*-cymene, but only the sharp and acid odor of other cyclization and resinification products.

These observations, in connection with the fine lemon-like odor of cyclo-citral, led Strausz²⁵ to express the tentative opinion that the citral occurring in lemon oil and the isocitral of Schmidt may be identical substances. As far back as 1926 Verley²⁶ had already ventured the opinion that the citral present in lemon oil is a special isomer of citral which he named γ -citral and to which he ascribed the formula

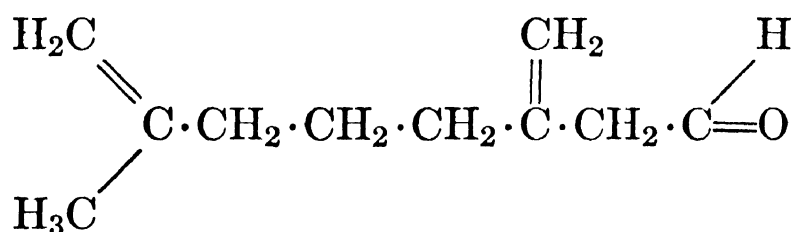

without, however, giving any experimental proof.

Schmidt,²⁷ and Strausz²⁸ tabulated the physicochemical properties of citral *a* (geranial), citral *b* (neral), and isocitral as follows:

	b ₁₂	b ₂	d ₂₀	d ₁₅	n _D ²⁰	Semi-carbazone m.	Cyanacetic Acid Compound m.	Naphthocinchonic Acid Compound m.
Citral <i>a</i> *	110°–112°	91°	0.8895	0.893	1.4891	164°	122°	202°
Citral <i>b</i> *	102°–104°	86°–88°	...	0.891	1.4900	171°	95°	200°
Isocitral	95°–97°	0.890	1.4838	140°	Liquid	196°

* The naphthocinchonic acid compounds of citral *a* and *b* show no melting point depression when mixed, but that of isocitral (196°) displays a depression of 6° when mixed with the others.

In the opinion of the authors, the contention that the citral occurring in lemon oil is identical with the isocitral of Schmidt cannot be accepted without more definite proof. It should be remembered that Poore²⁹ prepared from natural citral (isolated from California lemon oil) a naphthocinchonic acid compound m. 199°–200° (corr.), a semicarbazone of the *a* and *b* forms m. 134°–135°, and a semicarbazone of the *a* form m. 163°–164°, which data point toward the occurrence of citral *a* and *b* in California lemon oil.

Natural citral isolated from lemon oil probably owes its fine and mild odor to the absence of contaminating substances, such as methyl heptenone, which often accompany commercial citral derived from lemongrass oil.

Among the most interesting properties of citral are the condensations with substances containing a reactive methylene group. These condensations have become of great technical importance in the synthesis of the so-called ionones.

Use.—Citral is widely used in our industries, but usually only in small quantities for the compounding of synthetic lemon, lime and orange flavors. Citral, furthermore, serves for the scenting of soaps, cosmetics and as an adjunct in numerous perfume compositions.

- ¹ *Ber.* **26** (1893), 2708.
- ² *Ber.* **31** (1898), 3310, 3317.
- ³ *J. Am. Chem. Soc.* **46** (1924), 119.
- ⁴ *Ber.* **32** (1899), 117.
- ⁵ *Ber.* **31** (1898), 3317.
- ⁶ *Am. Perfumer* **32** (1936), No. 3, 67. *Chem. Abstracts* **30** (1936), 3403.
- ⁷ "Die Ätherischen Öle," 3d Ed., Vol. I, 515.
- ⁸ *Compt. rend.* **121** (1895), 1159.
- ⁹ *Ber.* **31** (1898), 3329.
- ¹⁰ *Ber.* **27** (1894), 354, 2026; **31** (1898), 1891, 3197.
- ¹¹ *J. Am. Chem. Soc.* **57** (1935), 758.
- ¹² *Ibid.* **57** (1935), 706.
- ¹³ *Ibid.* **52** (1930), 2955.
- ¹⁴ *Bull. Inst. Phys. Chem. Research Tokyo* **16** (1937), 7. Pub. with *Sci. Papers Inst. Phys. Chem. Research (Tokyo)* **13** (1937), 671. *Chem. Abstracts* **31** (1937), 6815.
- ¹⁵ *Rev. filipina med. farm.* **27** (1936), 123. *Chem. Abstracts* **31** (1937), 98.
- ¹⁶ *Ber.* **26** (1893), 2709.
- ¹⁷ "Die Ätherischen Öle," 3d Ed., Vol. I, 510.
- ¹⁸ *Ibid.*, 511.
- ¹⁹ *Ber.* **32** (1899), 117, 120; **33** (1900), 880.
- ²⁰ *J. prakt. Chem.* **82** (1910), 116.
- ²¹ *Ber.* **44** (1911), 992.
- ²² See also H. Schmidt, *Ber. Schimmel & Co.* (1938), 131; (1939), 114. *Chem. Zentr.* I (1940), 196.
- ²³ *Ber. Schimmel & Co.* (1938), 131; (1939), 114.
- ²⁴ *Perfumery Essential Oil Record* **38** (1947), 262. Cf. Verley, *Bull. soc. chim.* [3], **21** (1899), 408. Zeitschel and Schmidt, *J. prakt. Chem.* [2], **133** (1932), 370.
- ²⁵ *Perfumery Essential Oil Record* **38** (1947), 260.
- ²⁶ *Am. Perfumer* **21** (1926), 480.
- ²⁷ *Ber. Schimmel & Co.* (1939), 114.
- ²⁸ *Perfumery Essential Oil Record* **38** (1947), 260.
- ²⁹ *U. S. Dept. Agr., Tech. Bull.* No. 241, March (1932).

SUGGESTED ADDITIONAL LITERATURE

J. Bougault and E. Cattelain, "A Highly Sensitive Reaction for the Characterization and Determination of Citral," *J. pharm. chim.* **21** (1935), 437. *Chem. Abstracts* **29** (1935), 7578.

G. Dupont, V. Desreux and R. Dulou, "Spectrographic and Chemical Study of Aliphatic Terpenes. Alcohols and Aliphatic Aldehydes," *Bull. soc. chim.* [5], **4** (1937), 2016. *Chem. Abstracts* **32** (1938), 8270.

M. F. Carroll, "Structure of Certain Acyclic Isolates," *Perfumery Essential Oil Record* **38**, No. 7 (1947), 226.

Y. R. Naves, A. V. Grampoloff and P. Bachmann, "Études dans les Séries des Méthyl-3-linalols, des Méthyl-3-citrals et des Méthyl-6-ionones," *Helv. Chim. Acta* **30** (1947), 1599.

Citronellal

(Rhodinal)

 $C_{10}H_{18}O$

Mol. Weight 154.24

As in the case of citronellol and rhodinol, the constitution of citronellal and rhodinal, the corresponding aldehydes, has been the subject of much controversy. For details the reader is referred to Simonsen's "The Terpenes," Vol. I. Naturally occurring citronellal is not homogeneous and is regarded by some as being an inseparable mixture of the following two aldehydes in which either the one or the other form may predominate:

3,7-Dimethyl-7-octen-1-al

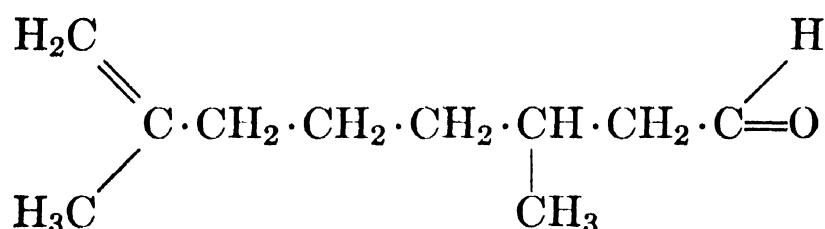

Limonene form
(Isopropenyl form)

3,7-Dimethyl-6-octen-1-al

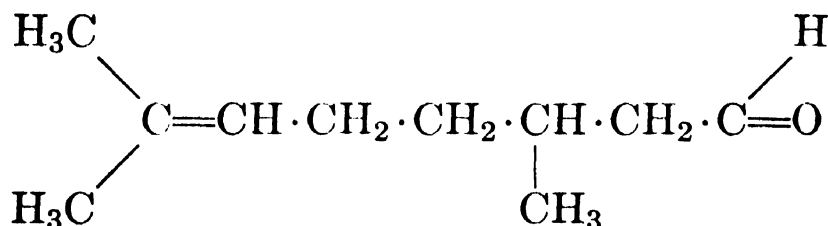

Terpinolene form
(Isopropylidene form)

Some authors declared citronellal and rhodinal different compounds, assigning the name rhodinal to the terpinolene form and the name true citronellal to the limonene form. However, this contention is generally not accepted.

The aliphatic terpene aldehyde citronellal is not widely distributed in nature. Occasionally it accompanies citral; in fact citronellal represents a di-

hydrocitra. Because of the presence of an asymmetric carbon atom, citronellal can exist in *d*-, *l*- and *dl*- form but only the *d*- form occurs in some oils in large quantities. A citronellal of low optical rotation is probably in most cases a mixture of both optically active forms.

Occurrence.—*d*-Citronellal occurs as the main constituent in oil of citronella, *Eucalyptus citriodora*, and a few other eucalyptus species. It has also been observed in oil of lemon and rose.

l-Citronellal occurs in "Java lemon olie" (a type of rare citronella oil no longer being produced), in oil of *Leptospermum flavescens* var. *citratum*, and a few other oils.

Isolation.—Citronellal may be isolated from essential oils and purified most conveniently through its crystalline bisulfite compound but, due to the instability of the aldehyde, great care must be exercised in decomposing the bisulfite compound. Citronellal contains an ethylenic linkage and an aldehydic group; therefore, three different bisulfite compounds are theoretically possible and actually have been prepared:

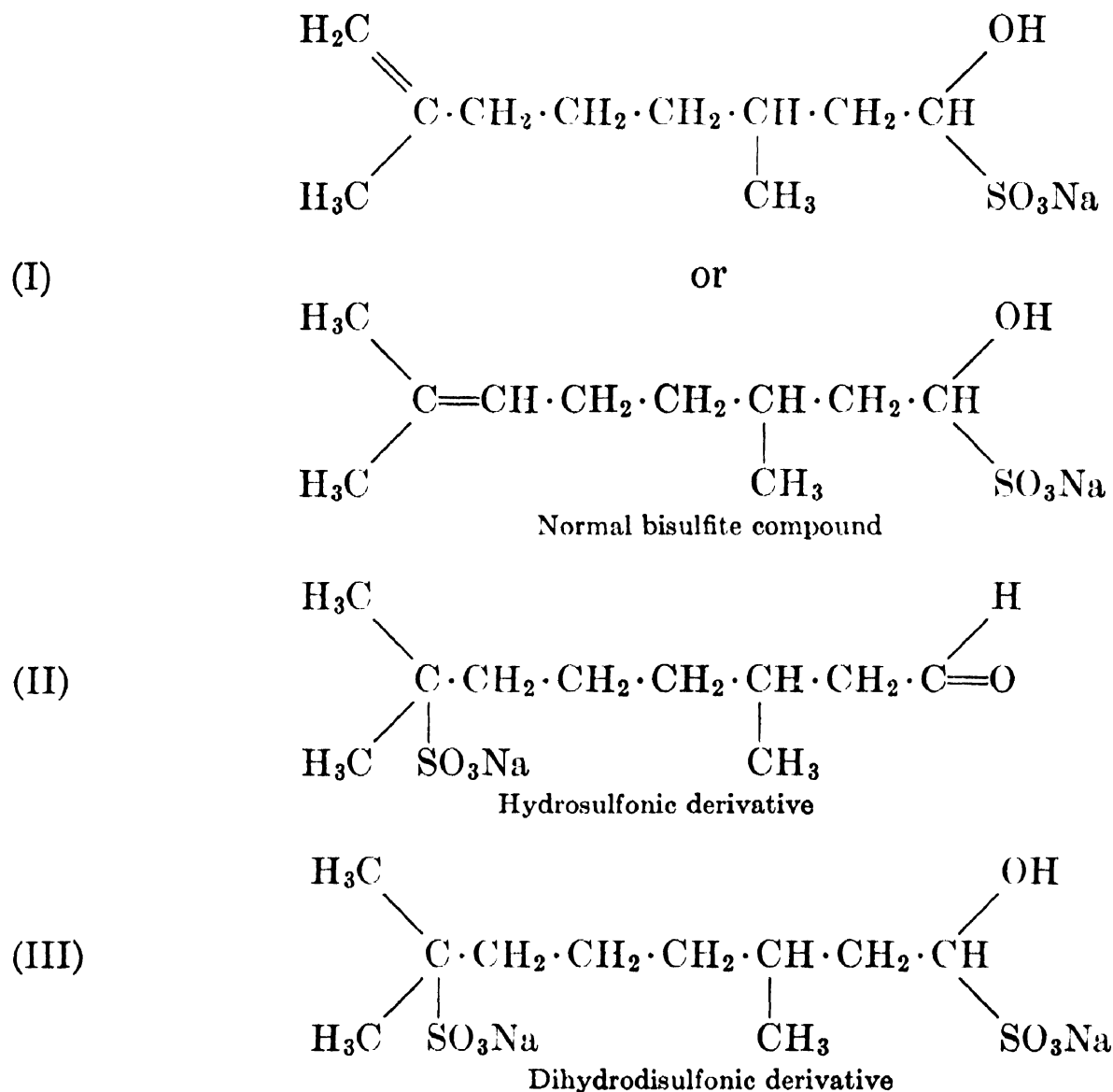

Tiemann¹ developed methods for the separation of citronellal, citral, and methyl heptenone. He showed that the normal bisulfite compound (I) is formed when citronellal is shaken with an ice-cold, aqueous solution (35%) of sodium bisulfite from which the excess of sulfur dioxide has been eliminated by a current of air. This crystalline bisulfite compound is soluble in warm water but partially decomposes in boiling water, with part regeneration of citronellal. Complete decomposition and regeneration

of the aldehyde can be effected quite easily by treatment of the normal bisulfite compound with dilute acids or alkalies, best with alkali carbonate, as alkali might easily affect this aldehyde.

The sulfonate derivative (III) is formed by treatment of citronellal with an excess of sodium bisulfite solution which contains some sodium sulfite. This crystalline compound may be isolated but it is very hygroscopic. Treatment of the compound with dilute alkali results in decomposition and conversion into the monoderivative (II) from which the citronellal cannot be regenerated either with soda or alkali solutions.

Thus, citronellal can be isolated, for example, from oil of citronella or *Eucalyptus citriodora*, according to Tiemann's ² procedure:

A 35% aqueous solution of sodium bisulfite is first freed from excess sulfurous acid by a current of air. The citronellal or the citronellal-containing fraction is then added together with pieces of ice and the mixture shaken. The separated normal sodium bisulfite compound (I) of citronellal is freed from adhering organic impurities by suction filtration, kneading with some alcohol and much ether and repeated suction filtration. The normal bisulfite compound can be decomposed quantitatively, at room temperature, by the action of soda or alkali solutions.

Zimmermann ³ suggested the following improvement of Tiemann's procedure:

Neutralize a 35% solution of anhydrous sodium sulfite, in the presence of phenolphthalein, with dilute sulfuric acid and add about 2% of sodium sulfate. After cooling, and while stirring, slowly add the volatile oil, and the sodium bisulfite compound of the citronellal will separate. The temperature should always be kept below 20° to 21°. Neutralize the alkaline liquid with acetic acid (10% aqueous solution) but only to such a degree that the mass remains slightly alkaline. After the rest of the oil has been added stir the mixture for another half hour, remove the precipitate, press and free from adhering essential oil by kneading the precipitate with ether in a mortar. Dissolve the dry precipitate in a very small volume of boiling water, cool the solution, place it in a separatory funnel, and shake with ether and concentrated soda solution until everything is dissolved. Separate the ether, wash with water, distill the ether, and purify the residual citronellal by rectification with steam.

With neutral sodium sulfite, too, citronellal forms hydrosulfonic derivatives (II and III) from which citronellal cannot be recovered. However, the reaction will start only if from the beginning a strong current of carbon dioxide is conducted through the mixture or if another acid is slowly added in sufficient quantities. This reaction of citronellal with neutral sulfite may serve for its separation from citral which also reacts readily with neutral sodium sulfite (see "Citral"). It is only necessary, in this case, to neutralize the nascent sodium hydroxide in the same measure as it is liberated in the course of the reaction (Gildemeister and Hoffmann ⁴).

Another procedure of separating citronellal and citral, according to Tiemann, ⁵ is based upon the fact that citronellal reacts only with a concentrated solution of sodium sulfite and sodium bicarbonate, whereas citral reacts even with a dilute solution.

Tiemann ⁶ also showed that his method can be applied to the separation of citronellal from small quantities of methyl heptenone, this ketone not reacting with concentrated solutions of neutral sodium sulfite and sodium bicarbonate.

An interesting fact in connection with the isolation of this compound has been observed by Waterman ⁷ who points out that citronellal can be obtained pure in a cathode light vacuum.

Quantitative Determination.—Regarding the quantitative determination of citronellal, see Vol. I, Chapter 4, "The Examination and Analysis of Essential Oils, Synthetics, and Isolates," p. 280.

For the determination of citronellal, Prins ⁸ suggested its reaction with formic acid (85–90% may be used); citronellal forms thereby isopulegyl formate.

Identification.—(1) Citronellal readily yields a semicarbazone which separates quantitatively on shaking an alcoholic solution of citronellal with a solution of semicarbazide hydrochloride and sodium acetate. The crude semicarbazone, on recrystallization successively from chloroform and ligroine, is obtained in the form of white laminae.

Best information on the *dl*- derivative records *m.* 96°, while that for the *l*- form is given by Schorger,⁹ who reports the isolation of *l*-citronellal from *Pinus jeffreyi* which yielded a semicarbazone *m.* 91°–92°. In the case of the *d*- compound, however, two forms have been recognized by Dœuvre,¹⁰ and by Prins¹¹ which may well correspond to the derivatives of the α - and β - forms of this aldehyde. The optima reported by these authors possibly representative of these forms are *m.* 77.5° and 86°, although the average figure usually given for the *d*- derivative is 83.5°.

(2) Rupe and Schlochoff¹² showed that citronellal condenses with acetone to citronellylidenacetone which yields a semicarbazide-semicarbazone *m.* 167°.

(3) According to Doebner,¹³ citronellal may also be identified by the preparation of citronellyl- β -naphthocinchonic acid *m.* 225°

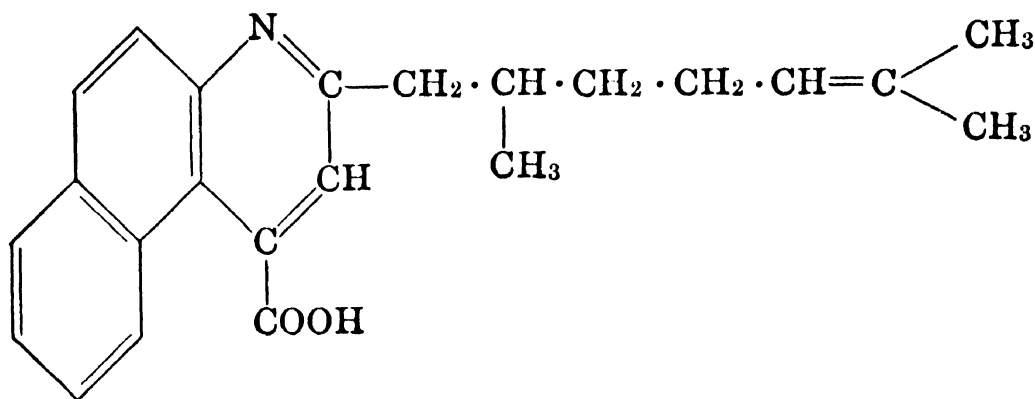

which is obtained by condensing (boiling) the aldehyde with β -naphthylamine and pyruvic acid. (For details see "Citral.") The crude product of condensation is recrystallized from alcohol containing hydrochloric acid, the hydrochloride thus obtained is dissolved in ammonia, the ammonium salt decomposed with acetic acid, and the compound recrystallized from dilute alcohol. The colorless needles melt at 225°. When heated above its melting point, the compound is converted into citronellyl- β -naphthoquinoline with cleavage of carbon dioxide. This base crystallizes from dilute alcohol or ligroine in silky needles *m.* 53°.

(4) Another characteristic derivative of citronellal, according to Tiemann,¹⁴ is citronellylidenecyanacetic acid *m.* 137°–138°. (Regarding its preparation, see "Citral.") This acid forms a characteristic, sparingly soluble sodium salt which may be used to separate citronellal from citral.

(5) The 2,4-dinitrophenylhydrazone of the active form has also been reported as *m.* 76.5°–78° by Allen¹⁵ and by Grundmann et al.¹⁶ as *m.* 76.5°.

(6) Henze and Speer¹⁷ prepared a hydantoin *m.* 172°–172.5°.

Properties.—Citronellal is a colorless liquid with a refreshing, melissa-like odor. The following properties have been reported:

d-Citronellal, purified through its bisulfite compounds (Tiemann,¹⁸ Tiemann and Schmidt,¹⁹ and Dœuvre²⁰):

b.	203°–204° ¹⁸	$d_{17.5}$	0.8554 ¹⁸
b_{24}	102°–103° ²⁰	$d_4^{17.5}$	0.8533 ²⁰
b_{14}	89°–91° ¹⁸	α_D^{18}	+10° 18' ²⁰
		$[\alpha]_D$	+12° 30' ¹⁹

The properties of technical preparations vary between these limits (Gildemeister and Hoffmann ²¹):

b.	205°–208°	α_D	+10° 0' to +11° 0'
b _{4.5}	72°–73°	n_D^{70}	1.444–1.452
d ₁₅ ¹⁵	0.855–0.860	Sol.	Soluble in 5–6 vol. of 70% alcohol

Prins ²² reported the isolation of two fractions of the *d*- isomer with the following characteristics:

	<i>I</i>	<i>II</i>
b.	203°–204°	198°–200°
d ₁₄	0.8880	0.8745
n_D^{14}	1.46141	1.45482

These products were probably contaminated with isopulegol, or partly resinified (Gildemeister and Hoffmann), whereas Docuvre ²³ isolated and characterized a citronellal from citronella oil (via bisulfite purification) which he reported as the β - form and which had the following properties:

b ₁₄	92°	$[\alpha]_{578}^{20}$	+13° 27'
d ₄ ²⁰	0.851	$[\alpha]_{546}^{20}$	+15° 52'
$[\alpha]_{436}^{20}$	+34° 56'	n_D^{20}	1.4467

l-Citronellal ²⁴ (from Java lemon olie)

b.	205°–208°	α_D	–3° 0'
d ₁₅ ¹⁵	0.8567	n_D^{20}	1.44791

Similar properties were reported for the laevo-isomer isolated from ethereal oil of *Pinus jeffreyi* by Schorger. ²⁵

The racemic mixture has not been as thoroughly studied as the active isolates. For a racemic mixture of citronellal, prepared by catalytic reduction of citral, Skita ²⁶ and Paal ²⁷ reported these data:

b ₁₅	106°–108° ²⁶
b ₁₀	79°–81° ²⁷
d ₄ ¹⁷	0.8535 ²⁷

Containing both an aldehydic group and an ethylenic linkage, citronellal is a highly reactive substance.

Oxidation under the influence of sunlight leads to a complex mixture, containing among others acetone, β -methyladipic acid, isopulegol, and menthone. When stored under improper conditions, citronellal may undergo far-reaching decomposition, resinification, and polymerization. Waterman and

Elsbach ²⁸ reported that citronellal is oxidized by air partly to citronellic acid, partly to peroxides.

Citronellal shows a strong tendency toward cyclization, especially under the influence of acid media, whereby isopulegol is formed. Indeed, this form of cyclization takes place so easily that commercial citronellal purified through its bisulfite compound often contains some isopulegol. Cyclization also occurs when citronellal is treated with 5 per cent sulfuric acid, with 85–90 per cent formic acid, or with 80 per cent phosphoric acid. By the action of acetic anhydride, isopulegol acetate is formed, the first product of the reaction being the acetate of the enolic form of citronellol and a small quantity of the diacetate.

Under the influence of alkalis, citronellal resinifies rapidly. For this reason, citronellal should be regenerated from its bisulfite compound with alkali carbonate and not with alkali hydroxides. Energetic oxidation with potassium permanganate solution yields the same products as citronellol, furthermore acetone and β -methyladipic acid. Gentle oxidation with silver oxide gives citronellic acid $C_{10}H_{18}O_2$. By reduction of citronellal with sodium amalgam, citronellol is obtained, which reaction finds wide application for the manufacturing of this important alcohol. Neuberg ²⁹ succeeded in reducing citronellal to citronellol enzymatically by means of yeast.

Use.—Citronellal is used in perfumes and for the scenting of soaps and all kinds of technical preparations. To a small extent it also serves in artificial citrus flavors.

¹ *Ber.* **31** (1898), 3306; **32** (1899), 812.

² *Ibid.*

³ *Pharm. Tijdschrift voor Nederlandsch-Indie* **5** (1928), 293.

⁴ "Die Ätherischen Öle," 3d Ed., Vol. I, 520.

⁵ *Ber.* **32** (1899), 815.

⁶ *Ibid.* 834.

⁷ *Chem. Weekblad* **27** (1930), 462.

⁸ *Ibid.* **14** (1917), 627.

⁹ *J. Ind. Eng. Chem.* **5** (1913), 972.

¹⁰ *Bull. soc. chim.* [4] **45** (1929), 1098.

¹¹ *Chem. Weekblad* **14** (1917), 692. *Chem. Zentr.* II (1917), 678. (Lab. N. V. Polak & Schwarz's Riechstoffabriken.)

¹² *Ber.* **36** (1903), 4377. Rupe and Lotz, *Ber.* **36** (1903), 2796.

¹³ *Ber.* **27** (1894), 2025.

¹⁴ *Ber.* **32** (1899), 824.

¹⁵ *J. Am. Chem. Soc.* **52** (1930), 2955.

¹⁶ *Liebigs Ann.* **524** (1936), 42.

¹⁷ *J. Am. Chem. Soc.* **64** (1942), 522.

¹⁸ *Ber.* **32** (1899), 818.

¹⁹ *Ber.* **29** (1896), 905.

²⁰ *Bull. soc. chim.* [4] **45** (1929), 1098.

²¹ "Die Ätherischen Öle," 3d Ed., Vol. I, 518.

²² *Chem. Weekblad* **14** (1917), 692. *Chem. Zentr.* II (1917), 678. (Lab. N. V. Polak & Schwarz's Riechstoffabriken.)

²³ *Bull. soc. chim.* **53** (1933), 589.

²⁴ *Ber. Schimmel & Co.*, April (1903), 21.

²⁵ *J. Ind. Eng. Chem.* **5** (1913), 972.

²⁶ *Ber.* **42** (1909), 1634.

²⁷ German Patent 298,193. *Chem. Zentr.* II (1917), 145.

²⁸ *Rec. trav. chim.* **53** (1934), 730.

²⁹ *Biochem. Z.* **92** (1918), 111.

SUGGESTED ADDITIONAL LITERATURE

Marston Taylor Bogert and Torsten Hasselström, "Action of Ultra-Violet Light on Terpenes. Action on Citronellal," *J. Am. Chem. Soc.* **52** (1930), 4093. *Chem. Abstracts* **24** (1930), 5743.

Établissements Roure-Bertrand Fils and Justin Dupont, "Determination of Citronellal," *Recherches* **1** (1937), 132. *Chem. Abstracts* **32** (1938), 6398.

G. Dupont, V. Desreux and R. Dulou, "Spectrographic and Chemical Study of Aliphatic Terpenes. Alcohols and Aliphatic Aldehydes," *Bull. soc. chim.* [5], **4** (1937), 2016. *Chem. Abstracts* **32** (1938), 8270.

Harry Schmidt, "Enol Acylates." *Ber. Schimmel & Co.* (1938), 140.

Charles C. Price and S. L. Meisel, "An Isomer of Citronellal," *J. Am. Chem. Soc.* **69**, No. 6 (1947), 1497.

M. F. Carroll, "Structure of Certain Acyclic Isolates," *Perfumery Essential Oil Record* **38**, No. 7 (1947), 226.

B. CYCLIC TERPENE ALDEHYDES

Perillaldehyde

(Dihydrocuminaldehyde)

$C_{10}H_{14}O$

Mol. Weight 150.21

4-Isopropenyl-1-cyclohexenaldehyde. 1,8(9)-*p*-Menthadien-7-al

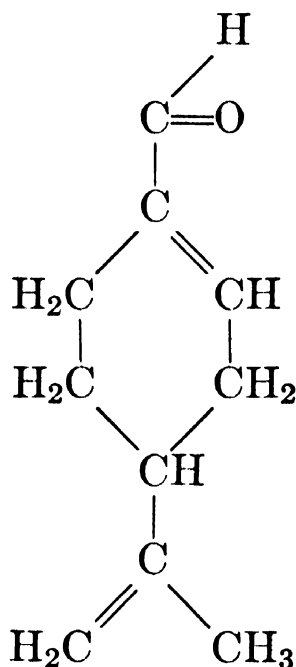

Occurrence.—*l*-Perillaldehyde occurs as main constituent (about 50 per cent) in perilla oil (*Perilla nankinensis* Decne).

d-Perillaldehyde in oil of *Hernandia peltata* ("false camphor wood"); in

Perilla ocimoides (Shiso oil) according to Hoshino,¹ and in sulphicia oil to the extent of 65 per cent (Huzita²).

Isolation.—Perillaldehyde can be isolated with neutral sodium sulfite or isolated and purified, according to Semmler and Zaar,³ through its crystalline compound with sodium bisulfite.

Identification.—Perillaldehyde may be characterized by the preparation of several derivatives:

(1) Semicarbazone m. 199°–200°.

(2) Phenylhydrazone m. 107.5°.

(3) Furukawa and Tomizawa⁴ found that the oxime is obtained in two forms, viz., the α -anti-oxime m. 102° (*l*-rotatory), and the β -syn-oxime m. 129°. The α -anti-oxime possesses an extremely sweet taste, the β -syn-oxime is tasteless.

Properties.—Perillaldehyde is an oil possessing a cumin-like odor. Schimmel & Co.,⁵ and Furukawa and Tomizawa⁶ reported the following properties:

b ₇₅₀	235°–237° ^{5,6}	α_D	–146° 0' ⁵
b ₉	104° ⁵	$[\alpha]_D$	–150° 42' ⁵
b _{4.5}	91° ⁵	$[\alpha]_D^{20}$	–145° 48' ⁶
d ₂₀	0.9645 ⁵	n _D ²⁰	1.50693 ⁵
d ₁₅	0.9675 ⁶ –0.9685 ⁵		

Semmler and Zaar⁷ recorded these properties for *l*-perillaldehyde:

b ₁₀	104°–105°	$[\alpha]_D$	–146° 0'
d ₁₈	0.9617	n _D	1.50746

The same authors found for the dextrorotatory form from "false camphor wood":⁸

b ₇₄₃	234°–236°	d ₁₅	0.973
b ₇	98°–100°	$[\alpha]_D$	+137° 40'
		n _D ²⁰	1.50802

A still more impure sample has been isolated from Shiso oil by Hoshino.⁹

When exposed to air, perillaldehyde is easily oxidized to perillic acid C₁₀H₁₄O₂, m. 132°–133°.

Use.—Perillaldehyde, as such, has not found any noteworthy application in the perfume and flavor industries.

¹ *J. Chem. Ind. Tokyo* **22** (1919), 969.

² *J. Chem. Soc. Japan* **61** (1940), 1213. *Chem. Abstracts* **36** (1942), 6754.

³ *Ber.* **44** (1911), 52, 815.

⁴ *J. Chem. Ind. Tokyo* **23** (1920), 342.

⁵ *Ber. Schimmel & Co.*, Oct. (1910), 136.

⁶ *J. Chem. Ind. Tokyo* **23** (1920), 342.

⁷ *Ber.* **44** (1911), 53.

⁸ *Ber.* **44** (1911), 815.

⁹ *J. Chem. Ind. Tokyo* **22** (1919), 969.

SUGGESTED ADDITIONAL LITERATURE

Shigehiro Abe, "The Chemical Constitution of Perillaldehyde, the Component of the Oil of *Perilla nankinensis*," *J. Chem. Soc. Japan* **64** (1943), 845. *Chem. Abstracts* **41** (1947), 3767.

Kiku Murata, "A Derivative of Perillaldehyde α -anti-oxime and its anti-fungous Power and Toxicity," *Rept. Osaka Municipal Research Inst. Domestic Sci.* **17**, No. 1 (1946), 191. *Chem. Abstracts* **41** (1947), 4785.

Phellandral

C₁₀H₁₆O

Mol. Weight 152.23

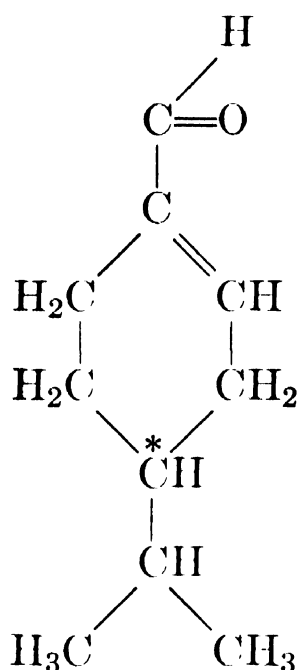
4-Isopropyl-1-cyclohexenaldehyde. 1-*p*-Menthen-7-al

The above structural formula of phellandral has been confirmed by Cooke, Macbeth and Swanson.¹

Occurrence.—First found in water fennel oil (*Phellandrium aquaticum* L.) by Schimmel & Co.² ($\alpha_D -36^\circ 30'$), this aldehyde occurs also in several eucalyptus species ("Box and Mallee" group)—for example, in the oils of *Eucalyptus hemiphloia*, *polybractea*, *bakeri* Maiden, and *cneorifolia*, in which it has been reported in all cases as *l*-phellandrene. However, Berry, Macbeth and Swanson,³ reinvestigating the isolate from water fennel oil, reported their aldehyde, contrary to Schimmel & Co., as *d*-phellandral ($\alpha_D +116^\circ 13'$).

Isolation.—*l*-Phellandral is isolated and purified by means of its sparingly soluble crystalline sodium bisulfite compound from which phellandral can be regenerated with alkali. Penfold⁴ recommended fractionating oil of *Eucalyptus hemiphloia*, and treating the fraction boiling above 185° at atmospheric pressure with pure 35% sodium bisulfite solution. The mixture of phellandral and cuminaldehyde thereby obtained may be separated by heating to boiling with the sodium bisulfite solution. Phellandral thereby dissolves as sulfonic acid salt, while the bisulfite compound of cuminaldehyde separates in the form of crystals. The phellandral is regenerated on treatment with sodium hydroxide.

Identification.—The active phellandrals may be characterized, according to Penfold,⁵ Schimmel & Co.⁶ and Iskenderov,⁷ by the preparation of their oxime m. 87°–88°, semicarbazone m. 204°–205°, and phenylhydrazone m. 122°–123°.

The *p*-nitrophenylhydrazone melts at 169°–170° and the 2,4-dinitrophenylhydrazone at 202°–203°, according to Macbeth and Price.⁸

Properties.—Phellandral is an oil possessing an odor reminiscent of cuminaldehyde.

l-Phellandral isolated from oil of *Eucalyptus hemiphloia* by Penfold⁹ had the following properties:

b_5	90°	α_D	–130° 51'
d_{20}	0.9412	n_D^{20}	1.4912

Cooke and Macbeth¹⁰ later prepared a sample isolated from *E. cneorifolia* and purified by means of the semicarbazone, with these properties:

$b_{1.5}$	75°
α_D^{20}	–151° 18'
$[\alpha]_D^{20}$	–160° 12'
n_D^{20}	1.4897

which represents an isolate with the maximum rotation thus far obtained.

d- α -Phellandral has been isolated from oil of water fennel (*Phellandrium aquaticum* L.) by Berry, Macbeth and Swanson¹¹ with an optical rotation of $\alpha_D +116^\circ 13'$ (2,4-dinitrophenylhydrazone m. 204°).

Schimmel & Co. had earlier described phellandral from this oil with a laevorotation and these properties:

b_5	89°	oxime	m. 87°–88°
d_{15}^{15}	0.9445	semicarbazone	m. 202°–204°
α_D	–36° 30'	phenylhydrazone	m. 122°–123°
n_D^{20}	1.4911		

Iskenderov,¹² by catalytic hydrogenation of perillyl alcohol, obtained $\Delta^{1,2}$ dihydroperillyl alcohol; oxidation of this compound gave this phellandral:

b_{11}	99°–102°	n_D^{20}	1.4910
d_{20}^{20}	0.9435	oxime	m. 87.8°
d_4^{20}	0.9409	semicarbazone	m. 204°
α_D	+36° 36'		

On exposure to air, and more readily with silver oxide, phellandral readily oxidizes to phellandric acid $C_{10}H_{16}O_2$, *d*-, *l*- m. 144°–145°, $[\alpha]_D^{20} \pm 112^\circ 36'$ to $\pm 112^\circ 48'$, *dl*- m. 143°–144°, according to Cooke, Macbeth and Swanson.¹³

Use.—Phellandral has not attained much importance in the perfume or flavor industries.

- ¹ *J. Chem. Soc.* (1940), 808.
- ² *Ber. Schimmel & Co.*, Oct. (1904), 91; Oct. (1905), 71.
- ³ *J. Chem. Soc.* (1937), 1448.
- ⁴ *Ibid.* **121** (1922), 266.
- ⁵ *Ibid.*
- ⁶ *Ber. Schimmel & Co.*, Oct. (1904), 91; Oct. (1905), 71.
- ⁷ *J. Gen. Chem. U.S.S.R.* **7** (1937), 1429. *Chem. Abstracts* **32** (1938), 126.
- ⁸ *J. Chem. Soc.* (1935), 152. See also Berry, Macbeth and Swanson, *J. Chem. Soc.* (1937), 986, 1448, and Cooke and Macbeth, *J. Chem. Soc.* (1938), 1412.
- ⁹ *Ibid.* **121** (1922), 266.
- ¹⁰ *Ibid.* (1938), 1412.
- ¹¹ *Ibid.* (1937), 1448.
- ¹² *J. Gen. Chem. U.S.S.R.* **7** (1937), 1429. *Chem. Abstracts* **32** (1938), 126.
- ¹³ *J. Chem. Soc.* (1940), 808.

SUGGESTED ADDITIONAL LITERATURE

G. Burger and A. Killen Macbeth (Univ. of Adelaide), "Carbonyl Constituents of Eucalyptus Oil. Constitution of Phellandral. *d*-, *l*-, and *dl*- β -Isopropyladipic Acids," *J. Chem. Soc.* (1946), 145. *Chem. Abstracts* **40** (1946), 4368.

Myrtenal

$C_{10}H_{14}O$

Mol. Weight 150.21

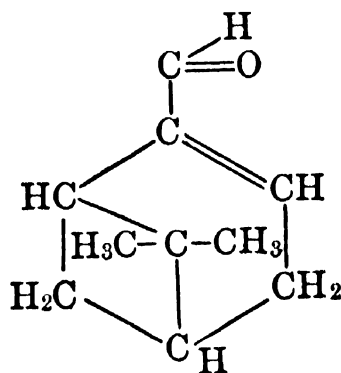

Occurrence.—Semmler and Zaar¹ discovered the dextrorotatory form of this unsaturated bicyclic aldehyde in the oil distilled from the wood of the so-called false camphor tree *Hernandia peltata* Meissn. Myrtenal occurs in this wood oil associated with perillaldehyde, a monocyclic compound. Myrtenal has recently been reported by Schmidt² in Spanish eucalyptus oil (*Eucalyptus globulus*).

Isolation.—By fractional distillation of the "false camphor wood" oil and by treating the fraction b. 215°–225° with neutral sodium sulfite solution. Both *d*-myrtenal and perillaldehyde combine with neutral sodium sulfite, but only *d*-myrtenal can be regenerated from this compound by the action of alkali.

Identification.—Schmidt,^{3,4} Semmler and Bartelt,⁵ Dupont, Zacharewicz and Dulou,⁶ Dupont and Zacharewicz,⁷ and Penfold, Ramage and Simonsen⁸ characterized the

isomeric forms of myrtenal by their semicarbazones and oximes, the melting points of which are noted:

<i>Derivative</i>	<i>d</i>	<i>l</i>	<i>dl</i>			
Semicarbazone	$\left\{ \begin{array}{l} 215^\circ \text{ }^4 \\ 220^\circ\text{--}221^\circ \text{ (dec.) } \text{ }^8 \\ 230^\circ \text{ }^5 \\ 225^\circ \text{ }^6 \end{array} \right.$	218° ³	$\left\{ \begin{array}{l} 200.5^\circ \text{ }^7 \\ 206^\circ \text{ }^6 \end{array} \right.$			
Phenylsemicarbazone				$\left\{ \begin{array}{l} 180^\circ \text{ (dec.) } \text{ }^8 \end{array} \right.$		
Oxime				$\left\{ \begin{array}{l} 69^\circ\text{--}70^\circ \text{ }^4 \\ 71^\circ\text{--}72^\circ \text{ }^5 \\ 70.5^\circ\text{--}71.5^\circ \text{ }^{6,7} \end{array} \right.$	69°–70° ³	101° ^{6,7}

Properties.—*d*-Myrtenal was isolated by Semmler and Zaar⁹ from the oil of the "false camphor tree," and by Schmidt¹⁰ from Spanish eucalyptus oil. When purified it had these properties:

<i>Semmler and Zaar</i>		<i>Schmidt</i>	
b ₁₁	89°–92°	b.	220°–221°
d ₂₀	0.9859	d ₁₅ ¹⁵	0.991
[α] _D	+13° 36'	α _D	+13° 13'
n _D	1.50618	n _D	1.50302

For *d*-Myrtenal prepared by the oxidation of *d*-myrtenol with chromic acid and purified through the semicarbazone, Rupe and Heretier¹¹ indicated the following properties:

b _{12.5}	91.8°–92°
d ₄ ²⁰	0.9898
[α] _D ⁰	+15° 41'

Dupont, Zacharewicz and Dulou¹² prepared both the inactive and the dextroisomer of this aldehyde by the oxidation of pinene with selenium dioxide and characterized both stereoisomers. The properties reported for the dextroisomers confirm those noted above; for the inactive form these authors reported:

d ₀	0.9969
n _D ²²	1.5036

Schmidt¹³ obtained *l*-myrtenal by the oxidation of *l*-β-pinene in the presence of cobalt siccative and reported the following properties:

b.	220°–221°	α _D	–15° 20'
d	0.992	n _D	1.50275

Because of the conjugation of the ethylenic linkage with the aldehyde group, myrtenal shows a very marked molecular exaltation (1.19).

Use.—Myrtenal, as such, is not used in our industries.

- ¹ *Ber.* **44** (1911), 815.
² *Ber. Schimmel & Co.* (1941), 56. *Chem. Abstracts* **37** (1943), 4714.
³ *Ber. Schimmel & Co.* (1941), 70. *Chem. Abstracts* **37** (1943), 4715.
⁴ *Ber. Schimmel & Co.* (1941), 56. *Chem. Abstracts* **37** (1943), 4714.
⁵ *Ber.* **40** (1907), 1370.
⁶ *Compt. rend.* **198** (1934), 1699.
⁷ *Bull. soc. chim.* [5], **2** (1935), 533.
⁸ *J. Proc. Roy. Soc. N. S. Wales* **68** (1934), 36.
⁹ *Ber.* **44** (1911), 817.
¹⁰ *Ber. Schimmel & Co.* (1941), 56. *Chem. Abstracts* **37** (1943), 4714.
¹¹ *Liebigs Ann.* **459** (1927), 178, 189.
¹² *Compt. rend.* **198** (1934), 1699.
¹³ *Ber. Schimmel & Co.* (1941), 70. *Chem. Abstracts* **37** (1943), 4715.

SUGGESTED ADDITIONAL LITERATURE

H. Rupe and Alwin Héritier, "Influence of the Constitution upon the Optical Activity of Optically Active Substances. Optically Active Myrtenyl Derivatives," *Liebigs Ann.* **459** (1927), 171. *Chem. Abstracts* **22** (1928), 1575.

Safranal

C₁₀H₁₄O

Mol. Weight 150.21

2,6,6-Trimethyl-1,3-cyclohexadien-1-al

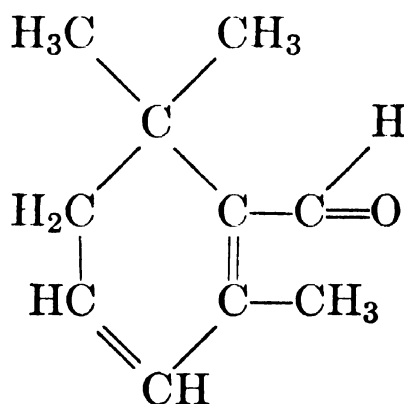

Aside from its specific organoleptic properties, safranal is of interest from the theoretical viewpoint inasmuch as it represents not only a natural product containing the important ionone ring, but is also a potential degradation product of carotene pigments; furthermore it is related to the termones.

Occurrence.—Years ago Kayser¹ showed that the bitter substance contained in safran (saffron) is a glucoside, viz., picrocrocin which, on treatment with acids or alkalis, can be split into glucose and a volatile compound C₁₀H₁₄O now recognized as safranal. More recently, Kuhn and collaborators^{2,3} demonstrated this active organic to be closely related with the androtermone present in a green alga (*Chlamydomonas eugametos* f. *Synoica*). Through enzymatic cleavage of picrocrocin they isolated by vacuum distillation 4-hydroxy-2,6,6-trimethyl-1-tetrahydrobenzaldehyde, which on dehydration readily yielded safranal.

Isolation.—Kuhn and A. Winterstein,⁴ following the scheme of E. Winterstein and Teleczky,⁵ extracted very fresh safran with ether (after the drug had first been extracted with petroleum ether) and obtained about 4% of picrocrocin $C_{16}H_{26}O_7$, m. 156°, tetra-acetate m. 143°. Decomposition of this glucoside gave the volatile aglucone $C_{10}H_{14}O$ to which Kuhn and A. Winterstein gave the name safranal:

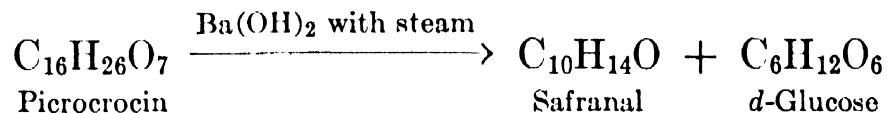

Further purification may be effected through the semicarbazone.

Identification.—According to Kuhn et al.^{6,7} safranal yields these characteristic derivatives:

	<i>m.</i> °C.
Oxime	65 ⁷
Thiosemicarbazone	199–200 ⁷
2,4-Dinitrophenylhydrazone	186 ⁷
Semicarbazone	175 (corr.) ⁶
Benzaldehyde compound	135–136 (corr.) ⁶

Properties.—The following properties have been reported by E. Winterstein and Teleczky,⁸ and Kuhn and A. Winterstein:⁹

b_{14}	93° ⁸	n_D^{19}	1.5281 ⁹
b_1	≈ 70° ⁹	Mol. refr.	$\left\{ \begin{array}{l} \text{Calc. 45.25}^9 \\ \text{Obs. 47.49}^9 \end{array} \right.$
d_4^{19}	0.9734 ⁹		
		EM_D	2.24 ⁹

Safranal possesses the characteristic odor of safran. The great sensitivity of the glucosides of terpene aldehydes explains the fact that on storing of the drug the content of the glucoside decreases considerably. Thus, aged safran no longer yields crystalline picrocrocin.

Kuhn and Wendt¹⁰ succeeded in synthesizing safranal by treating β -cyclo-citral with selenious acid.

Use.—Safranal, as such, is not offered on the market but it may be a constituent of certain flavor specialties.

¹ *Ber.* **17** (1884), 2228.

² *Ber.* **72B** (1939), 1702.

³ *Ber.* **74B** (1941), 219.

⁴ *Ber.* **67** (1934), 352. Cf. *Naturwissenschaften* **21** (1933), 527.

⁵ *Helv. Chim. Acta* **5** (1922), 376.

⁶ *Ber.* **67** (1934), 354.

⁷ *Ber.* **69** (1936), 1552.

⁸ *Z. physiol. Chem.* **120** (1922), 153.

⁹ *Ber.* **67** (1934), 354.

¹⁰ *Ber.* **69** (1936), 1549. Cf. German Patent No. 638,940, Nov. 25, 1936.

Nortricycloekasantalal

 $C_{11}H_{16}O$

Mol. Weight 164.24

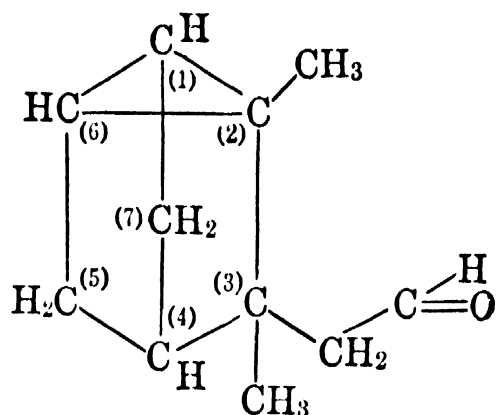

This tricyclic aldehyde is most probably identical with the nortricycloekasantalal obtained by Semmler and Zaar¹ through oxidation of nortricycloekasantalol with chromic acid.

Occurrence.—In East Indian sandalwood oil.

Isolation.—Schimmel & Co.² isolated and purified this aldehyde through its bisulfite compound.

Identification.—By the preparation of the semicarbazone m. 223°–224°. The oxime is an oil b₇ 135°–137°. The derived nortricycloekasantalic acid melts at 93°.

Properties.—According to Schimmel & Co.,³ the purified aldehyde is an oil of somewhat spicy odor and has these properties:

b ₇₆₁	222°–224°	α_D	–38° 48'
b ₆	86°–87°	n _D ²⁰	1.48393
d ₂₀	0.9938		

Use.—Nortricycloekasantalal has not found any use in our industries.

¹ *Ber.* **43** (1910), 1891.

² *Ber. Schimmel & Co.*, Oct. (1910), 103.

³ *Ibid.*

C. AROMATIC ALDEHYDES

Introduction.—Relative to the aliphatic aldehydes, the aromatic aldehydes play a much more important role in essential oils. In fact, some volatile oils—for example, bitter almond and cassia—consist almost entirely of aldehydes belonging to the aromatic series.

Benzaldehyde

C₇H₆O

Mol. Weight 106.12

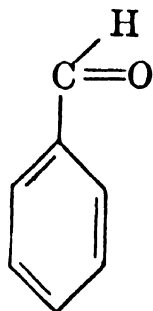

Occurrence.—This aromatic aldehyde probably does not occur as such in plants but in the form of glucosides—for instance, amygdalin. Under the influence of enzymes this glucoside is split into benzaldehyde, glucose, and hydrocyanic acid. In volatile oils benzaldehyde is, therefore, often accompanied by small quantities of hydrocyanic acid (see “Hydrocyanic Acid”).

Benzaldehyde has been found in quite a number of essential oils—for example, cinnamon bark and leaf oil, cassia, neroli, patchouly, cajuput, niaouli oil, acacia flower oil, etc. Volatile bitter almond, peach, and apricot kernel oils consist almost entirely of benzaldehyde.

Isolation.—With sodium bisulfite in concentrated aqueous solution, benzaldehyde readily forms a bisulfite addition compound from which the original aldehyde can be regenerated.

Identification.—Benzaldehyde may be characterized by the preparation of several crystalline derivatives:

(1) Hydrazone from N-methyl- β -carbohydrazidopyridinium *p*-toluene sulfonate m. 211° (corr.), by Allen and Gates.¹

(2) *p*-Iodobenzoylhydrazone m. 230°–231° (237°–238° corr.), by Sah and Hsü.²

(3) 2,4-Dinitrophenylhydrazone m. 237° (orange crystals from glacial acetic acid), according to Campbell.³

Properties.—Benzaldehyde is a colorless liquid possessing a powerful odor characteristic of crushed and moistened bitter almonds. Gildemeister and Hoffmann,⁴ and Pound⁵ recorded these properties:

b.	179° ⁴	n_D^{20}	1.544–1.546 ⁴
b ₇₃₃	177.3° ⁴		1.5460 ⁵
b ₅	45° ⁴	Sol.	Soluble in 8 vol. of 50% alcohol, in 2.5–3 vol. of 60% alcohol, in 1–1.5 vol. of 70% alcohol. Soluble in 200 vol. of water ⁴
d_4^{30}	1.0365 ⁵		
d_{15}^{15}	1.049–1.055 ⁴		

Benzaldehyde is volatile with steam. On exposure to air, benzaldehyde readily oxidizes to benzoic acid m. 121.4° which often separates in crystalline form from old and improperly stored lots of benzaldehyde. According to Gildemeister and Hoffmann,⁶ an addition of 10 per cent of alcohol prevents oxi-

dation by air, whereas an addition of less alcohol might accelerate the oxidation.

Owing to the danger of spontaneous ignition, bottles of benzaldehyde, when shipped, should be packed in diatomaceous earth (kieselguhr) or in kaolin, but not in wood shavings, sawdust, or cellulose.

When examining commercial (synthetic) benzaldehyde, it is advisable to test it for the presence (absence) of chlorine.

Use.—Benzaldehyde is widely used in flavors, also in perfumes, lotions, cosmetics, and soaps for creating or imparting bitter almond effects. It blends with heliotropin, vanillin, and coumarin.

¹ *J. Org. Chem.* **6** (1941), 599.

² *Rec. trav. chim.* **59** (1940), 352.

³ *Analyst* **61** (1936), 392.

⁴ "Die Ätherischen Öle," 3d Ed., Vol. I, 525.

⁵ *J. Phys. Chem.* **35** (1931), 1496.

⁶ "Die Ätherischen Öle," 3d Ed., Vol. I, 525.

Cumaldehyde

$C_{10}H_{12}O$

Mol. Weight 148.20

Cuminic aldehyde. *p*-Isopropylbenzaldehyde. Cuminal

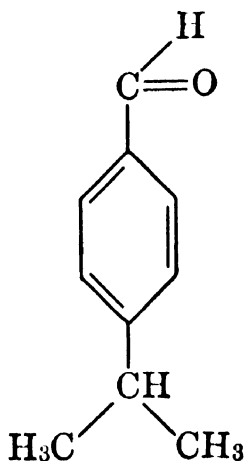

Occurrence.—Cumaldehyde is the main constituent of cumin seed oil. It has been observed also in several other volatile oils—for example, in oil of myrrh, Ceylon cinnamon, various eucalyptus oils, acacia flower oil, etc.

Isolation.—With sodium bisulfite in saturated aqueous solution, cumaldehyde yields an addition compound from which the original aldehyde can be regenerated by treatment with alkali.

Identification.—Cumaldehyde can be characterized by the preparation of several derivatives:

- (1) Semicarbazone m. 210° – 211° according to Gildemeister and Hoffmann.¹
- (2) Hydrazone from *N*-methyl- β -carbohydrazidopyridinium *p*-toluene sulfonate m. 259° (corr.), by Allen and Gates.²
- (3) *p*-Nitrophenylhydrazone m. 190° (crystals from alcohol), according to Baker, Nathan, and Shoppee.³
- (4) 2,4-Dinitrophenylhydrazone m. 243° (red crystals from glacial acetic acid), according to Campbell.⁴

Properties.—Cumaldehyde is an oil possessing a disagreeable odor characteristic of cumin seed. Volatile with steam. Gildemeister and Hoffmann,⁵ and Gladstone⁶ reported these properties:

b.	235.5° ⁵ (corr.)	d ₂₀	0.9775 ⁶
b _{13.5}	109.5° ⁵	d ₁₅ ¹⁵	0.9818 ⁵
		n _D ²⁰	1.5301 ⁶

On oxidation with alkaline potassium permanganate, cumaldehyde yields cumic acid m. 117° (from alcohol).

Use.—Cumaldehyde is used for the compounding of synthetic cumin oil which serves for the flavoring of curry sauces and of exotic dishes in general. Because of its powerful odor, this aldehyde must be used sparingly.

¹ "Die Ätherischen Öle," 3d Ed., Vol. I, 527. Cf. Warunis and Lekos, *Ber.* **43** (1910), 660.

² *J. Org. Chem.* **6** (1941), 599.

³ *J. Chem. Soc.* (1935), 1848.

⁴ *Analyst* **61** (1936), 392.

⁵ "Die Ätherischen Öle," 3d Ed., Vol. I, 527. Cf. Perkin, *J. Chem. Soc.* **69** (1896), 1199.

⁶ *J. Chem. Soc.* **45** (1884), 246.

Phenylacetaldehyde

C₈H₈O

Mol. Weight 120.14

α-Tolualdehyde

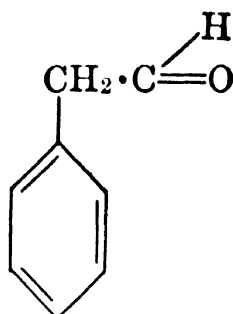

Occurrence.—This aromatic aldehyde has not yet been found in nature but should be described in these pages because of its importance in the compounding of perfumes.

Isolation.—On treatment with sodium bisulfite in saturated aqueous solution, phenylacetaldehyde forms a bisulfite addition compound from which the original aldehyde can be regenerated by steam distillation after addition of dilute sulfuric acid, alkali causing polymerization.

A patented process by Frisch¹ claims decomposition of the bisulfite complex at a specific temperature by means of formaldehyde, acetic acid, or acetone to separate the tolualdehyde from other contaminants.

Identification.—Phenylacetaldehyde may be characterized by the preparation of several derivatives:

- (1) Oxime m. 98.5° (from ether or ligroine), according to Wood and Comley.²
- (2) Semicarbazone m. 156° (from dilute alcohol), according to Henle.³
- (3) Hydrazone from N-methyl-β-carbohydrazidopyridinium *p*-toluene sulfonate m. 165° (corr.), by Allen and Gates.⁴

(4) 2,4-Dinitrophenylhydrazone m. 121° (from alcohol), according to Campbell.⁵ (Observed m. 110° by Brady; ⁶ reported m. 240° by Kharasch, Sternfeld and Mayo.⁷)

Properties.—The synthetic product is a colorless somewhat viscid oil of very powerful odor, characteristic of hyacinth. Gildemeister and Hoffmann,⁸ Etard,⁹ and Shumeiko¹⁰ reported these properties:

b.	193°–194° ⁹	d ₁₅	1.0423–1.0512 ¹⁰
b ₁₈	88° ⁸	n _D ²⁰	1.52536–1.53370 ⁸
b ₁₁	80° ⁸		1.5335–1.5337 ¹⁰
d ₁₅ ¹⁵	1.0315–1.0521 ⁸	Sol.	Soluble in 3 vol. of 70% alcohol ⁸

Phenylacetaldehyde is volatile with steam. The aldehyde has a strong tendency toward polymerization, even on standing at room temperature, and is, therefore, difficult to preserve without undergoing changes. On treatment with nitric acid, phenylacetaldehyde is oxidized to benzoic acid.

Use.—Phenylacetaldehyde is used quite widely in perfumes and in cosmetics. It serves in the compounding of hyacinth, narcissus, jonquil, jasmine, lilac, lily, certain rose types, and of general floral scents to which it imparts a refreshing top note, characteristic of hyacinth.

¹ British Patent No. 472,545, Sept. 23, 1937. See also Shumeiko, *J. App. Chem. U.S.S.R.* **14** (1941), 93; and Shorygin, Skoblinskaya and Frantsuz, *Sintezy Dushistykh Veshchestv, Sbornik, Stateĭ* (1939), 58. *Khim. Referat. Zhur.* No. 4 (1940), 112. *Chem. Abstracts* **36** (1942), 3794.

² *J. Soc. Chem. Ind.* **42** (1923), 432 T.

³ *Ber.* **38** (1905), 1366.

⁴ *J. Org. Chem.* **6** (1941), 599.

⁵ *Analyst* **61** (1936), 392.

⁶ *J. Chem. Soc.* (1931), 756.

⁷ *J. Org. Chem.* **5** (1940), 376.

⁸ "Die Ätherischen Öle," 3d Ed., Vol. I, 527.

⁹ *Ann. chim. phys.* [5], **22** (1881), 248.

¹⁰ *J. App. Chem. U.S.S.R.* **14** (1941), 93.

Cinnamaldehyde

C₉H₈O

Mol. Weight 132.15

Cinnamic aldehyde. β-Phenylacrolein

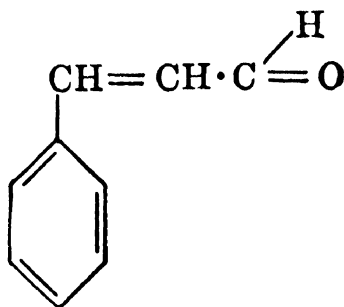

Occurrence.—This aromatic aldehyde is the main constituent of cassia leaf and bark oil, and of cinnamon bark oil. It has been found also in several other volatile oils—for example, in oil of myrrh and patchouly.

Isolation.—According to Tiemann,¹ through the sparingly soluble, normal addition compounds which cinnamaldehyde forms with sodium sulfite or sodium bisulfite in cold concentrated solution, and from which the original aldehyde can be regenerated with sodium carbonate. When separating cinnamaldehyde through the bisulfite compounds, an excess of hot sodium bisulfite solution should be avoided, as in this case a second molecule of sodium bisulfite would react with the cinnamaldehyde molecule, forming thereby the water soluble hydrosulfonic acid salt $C_6H_5 \cdot C_2H_3(SO_3Na) \cdot CH(OH)SO_3Na$ from which aqueous sodium hydroxide at ordinary temperature would regenerate only a part of the original cinnamaldehyde. The same is true if cinnamaldehyde is treated with a mixture of excess sodium sulfite and sodium bicarbonate.

Identification.—Cinnamaldehyde can be characterized by the preparation of several derivatives:

(1) Hydrazone from N-methyl- β -carbohydrazidopyridinium *p*-toluene sulfonate m. 182° (corr.), by Allen and Gates.²

(2) *p*-Nitrophenylhydrazone m. 195° (from alcohol), according to Hyde.³

(3) 2,4-Dinitrophenylhydrazone m. 255° with decomposition (from glacial acetic acid), according to Campbell.⁴

Properties.—Cinnamaldehyde is a yellow liquid possessing a powerful odor and flavor characteristic of cinnamon. Volatile with steam. Sparingly soluble in water, soluble in alcohol or ether. Insoluble in petroleum ether.

Gildemeister and Hoffmann,⁵ Altschul and von Schneider,⁶ and von Auwers and Eisenlohr⁷ recorded these properties:

m.	−7.5° ⁶	α_D	±0° ⁵
b.	252° ⁵ (partial de- composition)	n_D^{20}	1.61949 ⁵
		$n_D^{16.7}$	1.6235 ⁷
b_{20}	128°–130° ⁵	Sol.	Soluble in 25 vol. of 50% al- cohol, in 7 vol. of 60% al- cohol, in 2–3 vol. of 70% alcohol ⁵
$d_4^{16.7}$	1.0520 ⁷		
d_{15}^{15}	1.054–1.058 ⁵		

On exposure to air cinnamaldehyde readily oxidizes to cinnamic acid, finally to benzaldehyde and benzoic acid.

When examining commercial (synthetic) cinnamaldehyde, it is advisable to test it also for the presence (absence) of chlorine.

Use.—Because of its powerful odor, typical of cassia and cinnamon, cinnamaldehyde serves as a valuable ingredient in flavors and in perfumes for the imparting of spicy notes. It is also used widely for the scenting of soaps. Cinnamaldehyde is indispensable in the compounding of artificial cassia and cinnamon oils. (N.B. In white soap stock it causes discoloration.)

¹ *Ber.* **31** (1898), 3302.

² *J. Org. Chem.* **6** (1941), 599.

³ *Ber.* **32** (1899), 1814.

⁴ *Analyst* **61** (1936), 392.

⁵ "Die Ätherischen Öle," 3d Ed., Vol. I, 529.

⁶ *Z. physik. Chem.* **16** (1895), 24.

⁷ *J. prakt. Chem.* [2], **84** (1911), 65.

SUGGESTED ADDITIONAL LITERATURE

B. Stempel, "Volumetric Analysis of Cinnamaldehyde in *Cortex cinnamomi*," *Fette u. Seifen* **49** (1942), 42. *Chem. Abstracts* **37** (1943), 5196.

Marcel Mouton, "The Determination of Benzaldehyde and Cinnamaldehyde as 2,4-Dinitrophenylhydrazones and Its Possible Application to an Assay of Galenic Preparations of Cherry Laurel and Cinnamon," *Bull. sci. pharmacol.* **46** (1939), 148. *Chem. Abstracts* **33** (1939), 5128.

H. Wachsmuth and R. Lenaers, "Cinnamic Aldehyde—Determination of, and Other Essential Principles," *J. pharm. Belg.* **1**, No. 4, Jan. (1946), 65. *J. Am. Pharm. Assocn.* **36**, No. 11 (1947), 334.

Hydrocinnamaldehyde

C₉H₁₀O

Mol. Weight 134.17

β-Phenylpropionaldehyde. Benzylacetaldehyde

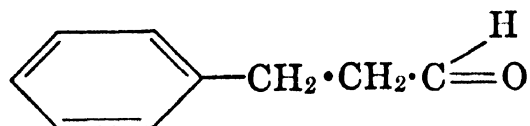

Occurrence.—Hydrocinnamaldehyde has been observed in Ceylon cinnamon oil.

Isolation.—Through the sodium bisulfite compound.

Identification.—By the preparation of derivatives:

(1) *p*-Nitrophenylhydrazone m. 122°–123° (needles from benzene and ligroine), according to Róna.¹

(2) 2,4-Dinitrophenylhydrazone m. 149° (corr.) (crystallized from alcohol), according to Allen and Richmond.²

(3) Hydrazone from 1-methyl-3-carbohydrazidopyridinium *p*-toluene sulfonate m. 160° (corr.), by Allen and Gates.³

Properties.—Gildemeister and Hoffmann⁴ recorded these properties:

b ₇₄₄	221°–224°	d ₁₅ ¹⁵	1.03
b ₁₃	104°–105°	Sol.	Soluble in about 2 vol. of 70% alcohol

Hydrocinnamaldehyde is an oil possessing a strong odor reminiscent of jasmine, hyacinth, and lilac. On exposure to air, hydrocinnamaldehyde oxidizes to hydrocinnamic acid m. 48.7°.

Use.—Hydrocinnamaldehyde is used widely but sparingly in all kinds of floral perfume compositions, especially lilac, jasmine, rose, and sweet pea.

¹ *Biochem. Z.* **67** (1914), 141.

² *J. Org. Chem.* **2** (1937), 224.

³ *Ibid.* **6** (1941), 599.

⁴ "Die Ätherischen Öle," 3d Ed., Vol. I, 530.

Salicylaldehyde

 $C_7H_6O_2$

Mol. Weight 122.12

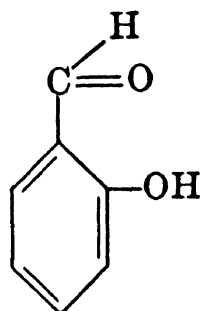
o-Hydroxybenzaldehyde.

Occurrence.—Small quantities of this aromatic aldehyde occur in the oils of various *Spiraea* species, in cassia oil, and in a few other volatile oils.

Isolation.—Salicylaldehyde reacts as a phenol and as an aldehyde; thus it is soluble in alkali solutions from which the aldehyde can be precipitated with carbon dioxide. It also forms an addition compound with sodium bisulfite in saturated aqueous solution, which crystallizes from 10% alcohol and from which the original aldehyde can be regenerated by treatment with dilute acids.

Identification.—Salicylaldehyde can be characterized by the preparation of several derivatives:

- (1) *p*-Nitrophenylhydrazone m. 227° (from alcohol), according to Biltz and Sieden.¹
- (2) 2,4-Dinitrophenylhydrazone m. 252° (with decomposition) (from glacial acetic acid), according to Campbell; ² m. 248° (from absolute alcohol), according to Curtius and Dedichen.³
- (3) *p*-Bromophenylhydrazone m. 171° – 172° , according to Gildemeister and Hoffmann; ⁴ m. 175.5° by Biltz and Sieden.⁵
- (4) *p*-Iodobenzoylhydrazone m. 214° – 215° (corr.) by Sah and Hsü.⁶

Properties.—Salicylaldehyde is an oil of characteristic aromatic odor. Volatile with steam. Sparingly soluble in water, miscible with alcohol and ether.

The following properties have been reported by Carswell and Pfeifer,⁷ von Auwers,⁸ Perkin,⁹ and Walden:¹⁰

f.p.	1.6° ⁷ pure	d_{25}	1.1539 ¹⁰
b.	197° ⁹ (corr.)	d_{20}^{20}	1.1690 ⁷
b_{751}	196.4° – 196.5° ⁷	n_D^{25}	1.57017 ¹⁰
b_{25}	93° ^{7,10}	$n_D^{19.7}$	1.574 ⁸

With an aqueous solution of ferric chloride the aldehyde gives an intense violet color. Oxidation of salicylaldehyde yields salicylic acid m. 158° .

Use.—Small quantities of salicylaldehyde are used in flavor work, also in the compounding of synthetic flower oils. The principal use, however, is a starting material for the synthesis of coumarin.

- ¹ *Liebigs Ann.* **324** (1902), 322.
- ² *Analyst* **61** (1936), 392.
- ³ *J. prakt. Chem.* [2], **50** (1894), 265.
- ⁴ "Die Ätherischen Öle," 3d Ed., Vol. I, 531.
- ⁵ *Liebigs Ann.* **324** (1902), 315.
- ⁶ *Rec. trav. chim.* **59** (1940), 349.
- ⁷ *J. Am. Chem. Soc.* **50** (1928), 1765.
- ⁸ *Liebigs Ann.* **408** (1915), 238.
- ⁹ *J. Chem. Soc.* **69** (1896), 1200.
- ¹⁰ *Z. physik. Chem.* **59** (1907), 395.

SUGGESTED ADDITIONAL LITERATURE

B. G. Feinberg, "Quantitative Study of Some Aldehyde Reactions," *Am. Chem. J.* **49** (1913), 87.

p-AnisaldehydeC₈H₈O₂

Mol. Weight 136.14

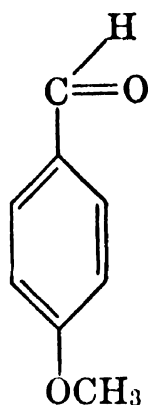
p-Methoxybenzaldehyde. "Aubépine"

Occurrence.—Since this aromatic aldehyde is formed by oxidation of anethole, it usually occurs in old essential oils which contain anethole—oil of anise, star anise, and fennel, for example. Anisic aldehyde has been found also in acacia flower oil, and in a few other oils. Interesting is the occurrence of anisaldehyde in the extract of Tahiti vanilla beans.

Isolation.—Through the bisulfite compound.

Identification.—Anisaldehyde may be characterized by the preparation of several derivatives:

(1) Semicarbazone m. 210°, according to Wilson and Keenan;¹ 2-benzylthiosemicarbazone m. 175°, by Cattelain.²

(2) *p*-Nitrophenylhydrazone m. 160°–161°, according to Hebert.³

(3) 2,4-Dinitrophenylhydrazone m. 253°–254° with decomposition (from glacial acetic acid), according to Campbell.⁴ (Cf. Brady,⁵ and Nauta and Mulder⁶ who report m. 250°.)

Oxidation of *p*-anisaldehyde with dilute potassium permanganate leads to *p*-anisic acid m. 184.2°.

Properties.—Anisaldehyde is a colorless to yellowish oil, possessing a strong odor characteristic of blooming hawthorn. Miscible with alcohol or ether.

Volatile with steam. Gildemeister and Hoffmann,⁷ Jaeger,⁸ and von Auwers⁹ reported these properties:

m.	2.5° ⁸	d_4^{20}	1.123 ⁹
b.	247° ⁹	d_{15}^{15}	1.127–1.130 ⁷
b ₇₅₁	246° ⁸	n_D^{20}	1.571–1.575 ⁷
b ₅	106°–107° ⁷		1.5731 ⁹
Sol.	Soluble in 7–8 vol. of 50% alcohol; soluble in 300 vol. of water with slight opalescence ⁷		

On exposure to air, anisaldehyde is oxidized to *p*-anisic acid m. 184.2° (corr.).

Use.—Very useful in general perfume work and for the scenting of soaps, particularly in lilac, heliotrope, hawthorn, acacia, mimosa, new mown hay, and sweet pea compositions.

¹ *J. Assocn. Official Agr. Chem.* **13** (1930), 390, 393.

² *Compt. rend.* **209** (1939), 799. *Bull. soc. chim.* [5], **7** (1940), 791.

³ *Bull. soc. chim.* [4], **27** (1920), 52. Also cf. Feinberg, *Am. Chem. J.* **49** (1913), 87; Iddles and Jackson, *Ind. Eng. Chem., Anal. Ed.*, **6** (1934), 454; Harvill and Herbst, *J. Org. Chem.* **9** (1944), 21.

⁴ *Analyst* **61** (1936), 392.

⁵ *J. Chem. Soc.* (1931), 756.

⁶ *Rec. trav. chim.* **58** (1939), 1062.

⁷ "Die Ätherischen Öle," 3d Ed., Vol. I, 532.

⁸ *Z. anorg. allgem. Chem.* **101** (1917), 142.

⁹ *Liebigs Ann.* **408** (1915), 240.

p-Methoxycinnamaldehyde

C₁₀H₁₀O₂

Mol. Weight 162.18

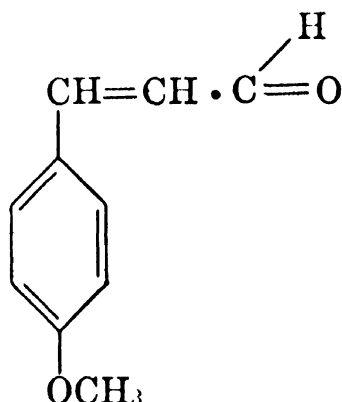

Occurrence.—This aromatic aldehyde occurs in estragon oil.

Isolation.—The aldehyde readily forms a bisulfite addition compound which is sparingly soluble in water and from which it is not readily regenerated.

Identification.—According to Gildemeister and Hoffmann,¹ *p*-methoxycinnamaldehyde can be characterized by the preparation of its semicarbazone m. 222° (Scholtz and Wiedemann² reported 199°), and of its oxime m. 154°.

Oxidation with potassium permanganate in acid solution yields *p*-anisic acid (*p*-methoxybenzoic acid) m. 184.2° (corr.), while oxidation with silver oxide leads to *p*-methoxycinnamic acid m. 170°.

Properties.—Daufresne,³ who isolated this aldehyde from estragon oil, reported these properties:

b ₁₅	171°
d ₀	1.137

Scholtz and Wiedemann⁴ found the synthetic aldehyde to melt at 58°.

Use.—Small quantities of the synthetic product are used for the compounding of imitation estragon oil.

¹ "Die Ätherischen Öle," 3d Ed., Vol. I, 533.

² *Ber.* **36** (1903), 853.

³ *Compt. rend.* **145** (1907), 875.

⁴ *Ber.* **36** (1903), 853.

o-Methoxycinnamaldehyde

C₁₀H₁₀O₂

Mol. Weight 162.18

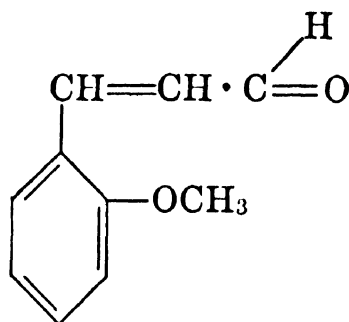

Occurrence.—This aldehyde occasionally occurs in cassia oil and separates from the high boiling fractions in the form of a crystalline deposit.

Isolation.—Forms a water soluble complex with sodium bisulfite which is readily decomposed by acids to regenerate the aldehyde.

Identification.—According to Gildemeister and Hoffmann,¹ the aldehyde can be characterized by the preparation of its phenylhydrazone m. 116°–117°, and of its oxime m. 125°–126°.

Oxidation with potassium permanganate yields *o*-methoxybenzoic acid m. 99°; treatment with silver oxide leads to β -methyleumaric acid m. 182°–183°.

Properties.—Bertram and Kürsten² reported these properties:

m.	45°–46°
b.	295° (with part decomposition)
b ₁₂	160°–161°

The aldehyde is very unstable and readily decomposes even without exposure to air and light. It imparts an intensely yellow color to the skin.

Use.—*o*-Methoxycinnamaldehyde is not used in our industries.

¹ "Die Ätherischen Öle," 3d Ed., Vol. I, 533.

² *J. prakt. Chem.* II, **51** (1895), 316.

Vanillin

 $C_8H_8O_3$

Mol. Weight 152.14

4-Hydroxy-3-methoxybenzaldehyde. Protocatechualdehyde-3-methyl ether

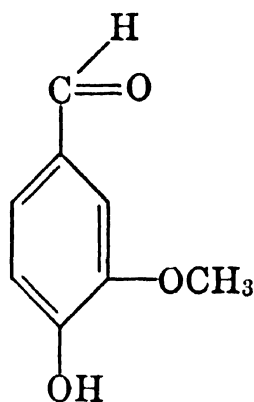

Occurrence.—This important aromatic aldehyde is widely distributed in nature, although it occurs in essential oils, gums, and balsams only in small quantities. Most likely plants do not contain vanillin as such but in the form of glucosides which by enzyme action release vanillin. The most important source of natural vanillin is the vanilla bean (fruit). Vanillin occurs also in gum benzoin, Peru balsam, clove oil, etc.

Isolation.—Through the bisulfite compound. From ether solutions vanillin can be extracted completely with saturated aqueous sodium bisulfite solutions, but the sodium bisulfite compound is quite soluble. Specialized techniques must be employed to insure pure isolates in the event closely related isomers and tautomers are to be expected.

Identification.—Vanillin can be characterized by the preparation of numerous derivatives, among them:

(1) Semicarbazone m. 230° , according to Wilson and Keenan;¹ 4-(*p*-nitrophenyl)-semicarbazone m. 261° , by Barré and Piche.²

(2) Hydantoin m. 276° , by Henze and Speer.³

(3) *p*-Nitrophenylhydrazone m. 227° (leaflets from glacial acetic acid), according to Biltz and Sieden.⁴

(4) 2,4-Dinitrophenylhydrazone m. 271° (with decomposition), (red crystals from glacial acetic acid), according to Campbell;⁵ Brickman et al.⁶ observed 261° – 262° .

Gildemeister and Hoffmann⁷ recommended several additional derivatives as useful for the identification of vanillin, among them:

(5) Acetyl compound m. 77° .

(6) Benzoate m. 75° .

(7) *p*-Bromophenylhydrazone m. 148° .

Properties.—According to Gildemeister and Hoffmann,⁸ vanillin crystallizes from hot water in the form of colorless needles m. 81° – 82° . (Cf. also Arana,⁹ and Freudenberg et al.¹⁰) It possesses a strong and intensely sweet odor characteristic of vanilla. On careful heating, vanillin can be sublimated without decomposition; by prolonged heating at 105° vanillin decomposes

with formation of nonvolatile products. The same authors reported these boiling points of vanillin:

b.	285° (in a current of CO ₂)
b ₁₅	170°
b ₁₀	162°
b ₄	146°

Vanillin is readily soluble in alcohol, ether, chloroform, and hot ligroine; insoluble in cold ligroine; soluble in hot water, relatively insoluble in cold water, for which reason vanillin can be recrystallized from water. At 75°–80°, 1 part of vanillin dissolves in 20 parts of water, at 14° in 90–100 parts of water. At 7°–8° the greater part of vanillin will gradually crystallize from the water. Vanillin is soluble in sodium carbonate solution, but not in sodium bicarbonate solution.

Use.—Vanillin is the main ingredient in artificial vanilla flavors. Used most extensively for the flavoring of confectionery, baked goods, candies, chocolates, etc. Vanillin serves widely also in perfumes and cosmetics for imparting sweet and lasting notes. It blends well with heliotropin and coumarin. Used in floral and fancy scents alike.

¹ *J. Assocn. Official Agr. Chem.* **13** (1930), 390, 396. Cf. Knöpfer, *Monatsh.* **31** (1910), 103; and Brickman, Hawkins and Hibbert, *J. Am. Chem. Soc.* **62** (1940), 2149.

² *Can. J. Res.* **20B** (1942), 19.

³ *J. Am. Chem. Soc.* **64** (1942), 522.

⁴ *Liebigs Ann.* **324** (1902), 323.

⁵ *Analyst* **61** (1936), 392.

⁶ *J. Am. Chem. Soc.* **62** (1940), 2153.

⁷ "Die Ätherischen Öle," 3d Ed., Vol. I, 536.

⁸ *Ibid.*

⁹ *Puerto Rico Agr. Expt. Sta., Ann. Rept. of 1939* (1940), 2. *Chem. Abstracts* **36** (1942), 5319.

¹⁰ *Ber.* **73B** (1940), 169.

SUGGESTED ADDITIONAL LITERATURE

Irwin A. Pearl (Inst. Paper Chemistry, Appleton, Wis.), "Reactions of Vanillin," *J. Am. Chem. Soc.* **67** (1945), 1628. *Chem. Abstracts* **40** (1946), 70.

Juan de D. Guevara R., "The Assay of Preparations Containing Vanillin," *Farmacia y quím.* (Lima, Peru) **1** (1945), 240. *Chem. Abstracts* **40** (1946), 2932.

Irwin A. Pearl (Inst. Paper Chemistry, Appleton, Wis.), "Reactions of Vanillin and Its Derived Compounds. The Reaction of Vanillin with Silver Oxide," *J. Am. Chem. Soc.* **68** (1946), 429. *Chem. Abstracts* **40** (1946), 2813.

Irwin A. Pearl, "Reactions of Vanillin and Its Derived Compounds. The Cannizzaro Reaction of Vanillin," *J. Org. Chem.* **12**, No. 1 (1947), 79.

R. Fischer and G. Kocher, "Determination of Vanillin and Ethyl Ether Vanillin (Bourbonal)," *Mikrochemie ver. mikrochim. Acta* **33** (1947), 131. *Chem. Abstracts* **42** (1948), 2058.

4-Methoxysalicylaldehyde

 $C_8H_8O_3$

Mol. Weight 152.14

2-Hydroxy-4-methoxybenzaldehyde. 2-Hydroxyanisaldehyde.

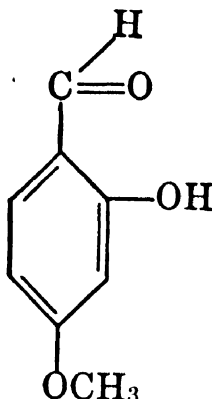

Occurrence.—This aromatic aldehyde has been found in the oil distilled from the roots of *Decalepis hamiltonii*.

Isolation.—Extracted with alkali as a yellow colored solution. Readily volatile with steam. Crystallizes from water in which the ethereal aldehyde is only moderately soluble.

Identification.—Through the oxime m. 137° – 138° . Alkaline solutions of the compound are colored intensely violet with iron chloride.

Conversion to the dimethyl ether m. 71° (Gattermann¹) which in turn yields an oxime m. 106° .

Properties.—According to Friedlaender and Schuloff² m. 41° . Characteristic aromatic odor, suggestive of vanillin.

Use.—4-Methoxysalicylaldehyde is not used in our industries.

¹ *Ber.* **31** (1898), 1152. *Liebigs Ann.* **357** (1907), 369.

² *Monatsh.* **29** (1908), 390.

“Methylvanillin”

 $C_9H_{10}O_3$

Mol. Weight 166.17

Veratraldehyde. 3,4-Dimethoxybenzaldehyde. Protocatechualdehyde dimethyl ether. Vanillin methyl ether

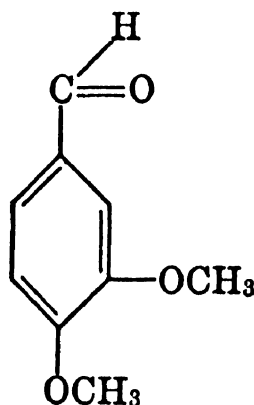

Occurrence.—Methylvanillin occurs in oil of *Cymbopogon javanensis*.

Isolation.—Through the crystalline sodium bisulfite compound.

Identification.—By the preparation of derivatives:

- (1) Hydantoin m. 182.5°–183°, by Henze and Speer.¹
- (2) Phenylhydrazone m. 121° (crystallized from alcohol), according to Juliusberg.²
- (3) 2,4-Dinitrophenylhydrazone m. 261°–263° (from nitrobenzene), according to Strain.³

Properties.—Puxeddu,⁴ Tiemann,⁵ and Gildemeister and Hoffmann⁶ recorded these properties:

m.	42° ⁴	d	1.151 ⁶
b.	285° ⁵	n _D	1.551 ⁶

Almost insoluble in cold water, more soluble in hot water. Readily soluble in alcohol or ether. Only very slowly volatile with steam.

Use.—Methylvanillin is not used in our industries. However, “ethylvanillin” or “bourbonal” (protocatechualdehyde-3-ethyl ether) m. 77.5°

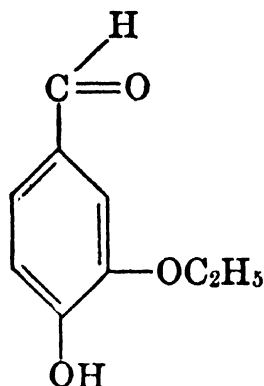

serves widely in the flavor industry as an adjunct to, or substitute for vanillin, being intensely sweet and reported by Defren⁷ and Boyles⁸ to possess 3½ to 4 times the flavoring value of vanillin. “Ethylvanillin” has not been identified in nature.

¹ *J. Am. Chem. Soc.* **64** (1942), 522.

² *Ber.* **40** (1907), 119.

³ *J. Am. Chem. Soc.* **57** (1935), 760.

⁴ *Atti accad. Lincei (Rendiconti)* [5], **20**, II (1911), 721.

⁵ *Ber.* **8** (1875), 1135.

⁶ “Die Ätherischen Öle,” 3d Ed., Vol. I, 538.

⁷ *Food Ind.* **1** (1929), 661.

⁸ *Am. Perfumer* **25** (1930), 243.

Piperonal

 $C_8H_6O_3$

Mol. Weight 150.13

3,4-Methylenedioxybenzaldehyde. Heliotropin

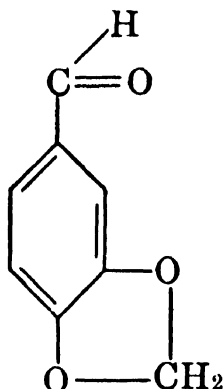

Occurrence.—It remains doubtful whether this aromatic aldehyde occurs in the beans (fruit) of various vanilla species, also whether the odor of heliotrope flowers is due to piperonal. Traces of piperonal have, however, been found in a few flower oils such as *Spiraea ulmaria* and *Robinia pseudacacia*. Recently reported in pha-chium oil by Ikeda et al.¹

Isolation.—Through the crystalline bisulfite compound which is sparingly soluble in water or alcohol.

Identification.—Piperonal can be characterized by the preparation of several derivatives:

- (1) Semicarbazone m. 234°, according to Wilson and Keenan.²
- (2) *p*-Nitrophenylhydrazone m. 201°, recorded by Quilico and Freri.³
- (3) 2,4-Dinitrophenylhydrazone m. 266° with decomposition (red crystals from glacial acetic acid), according to Campbell.⁴
- (4) Hydantoin m. 207°, by Henze and Speer.⁵

Gildemeister and Hoffmann⁶ recorded some additional derivatives and reactions useful for the identification of piperonal:

- (5) Monobromo compound m. 129°.
- (6) Mononitro compound m. 94.5°.
- (7) Thiosemicarbazone m. 185°.
- (8) *p*-Bromophenylhydrazone m. 155°.
- (9) Oxidation with aqueous potassium permanganate at 70°–80° yields piperonylic acid m. 227.5°–228°.
- (10) On addition of 40 per cent sodium hydroxide solution to an emulsion of piperonal, acetone and water, piperonalacetone m. 107°–108° is formed.

Properties.—Piperonal consists of colorless, shiny crystals m. 35°–36° according to Gildemeister and Hoffmann;⁷ 37° according to Othmer,⁸ and Fittig and Mielck.⁹ It possesses a sweet, flower-like odor, characteristic of heliotrope. Readily volatile with steam. The boiling point at 760 mm. is 263°. Gildemeister and Hoffmann¹⁰ also reported that piperonal is soluble in the usual organic solvents, sparingly soluble in cold water, more readily in hot water from which it can be recrystallized in the form of large crystals. Solu-

bility in water 2 : 1000 at 12°. Five parts of piperonal are soluble in 100 parts of 70 per cent alcohol at 10°.

When testing piperonal for the presence of impurities, it is advisable to determine its melting point and its behavior toward sodium bisulfite with which piperonal reacts readily.

On exposure to light and air, piperonal turns yellow and finally decomposes, being very slowly oxidized to piperonylic acid. It should, therefore, be stored in a cool, dark place and in airtight containers.

Use.—Piperonal is used widely in perfumery and for the scenting of cosmetics and soaps. Due to its distinct heliotrope odor it serves in lilac, carnation, sweet pea, and in fancy bouquets of all types. Piperonal blends well with coumarin and vanillin and imparts a lasting sweetness wherever used.

¹ *J. Chem. Soc. Japan* **61** (1940), 583. *Chem. Abstracts* **36** (1942), 6754.

² *J. Assocn. Official Agr. Chem.* **13** (1930), 390, 395.

³ *Gazz. chim. ital.* **58** (1928), 389.

⁴ *Analyst* **61** (1936), 392.

⁵ *J. Am. Chem. Soc.* **64** (1942), 522.

⁶ "Die Ätherischen Öle," 3d Ed., Vol. I, 539.

⁷ *Ibid.*

⁸ *Z. anorg. allgem. Chem.* **91** (1915), 212, 226, 242.

⁹ *Liebigs Ann.* **152** (1869), 38.

¹⁰ "Die Ätherischen Öle," 3d Ed., Vol. I, 539.

SUGGESTED ADDITIONAL LITERATURE

"Specifications and Standards" of the Essential Oil Association of the United States, January 10, 1947.

Asaronaldehyde

$C_{10}H_{12}O_4$

Mol. Weight 196.2

2,4,5-Trimethoxybenzaldehyde. Asarylaldehyde

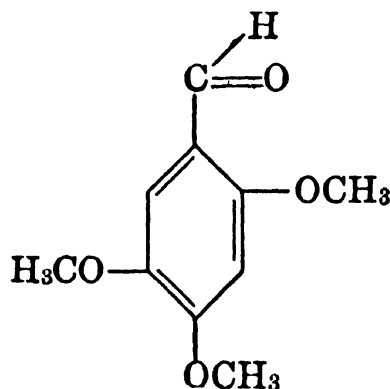

Occurrence.—Gerö¹ found in the volatile oil derived from the roots of wild Hungarian hazelnut, *Asarum europaeum* L. (fam. *Aristolochiaceae*), an aldehyde, viz., asaronaldehyde, which, according to mixed melting point determination with an authentic sample, proved to be 2,4,5-trimethoxybenzaldehyde.

Van Alphen ² was able to show that freshly distilled calamus oil (*Acorus calamus* L.) does not contain asaronaldehyde but old oils of the same type may yield this aldehyde, as originally reported by Thoms and Beckstroem.³

Isolation.—According to the same authors,⁴ asaronaldehyde is easily isolated by means of its bisulfite addition product.

Identification.—By the preparation of derivatives, according to van Alphen: ⁵

(1) Semioxamazone (C₁₅H₁₅O₅N₃), m. 249°–250°.

(2) *p*-Nitrophenylhydrazone m. 234°. This derivative has been found useful to detect the aldehyde in very small quantities.

(3) Careful treatment with nitric acid and acetic anhydride yields 2,4,5-methoxy-nitrobenzene m. 130°.

Properties.—m. 114°, according to Gerö.⁶

The aldehyde is sparingly soluble in cold water but easily soluble in ether, benzene, or ligroine.

Use.—Asaronaldehyde, as such, is not used in our industries.

¹ *Riechstoff Ind.* **3** (1928), 176. *Ber. Schimmel & Co.* (1929), 49. *Chem. Abstracts* **24** (1930), 2235.

² *Rec. trav. chim.* **46** (1927), 195.

³ *Ber.* **34** (1901), 1021.

⁴ *Ibid.*

⁵ *Rec. trav. chim.* **46** (1927), 195; **47** (1928), 174.

⁶ *Riechstoff Ind.* **3** (1928), 176. *Ber. Schimmel & Co.* (1929), 49. *Chem. Abstracts* **24** (1930), 2235.

D. HETEROCYCLIC ALDEHYDES

Furfural

C₅H₄O₂

Mol. Weight 96.08

α -Furfuraldehyde. 2-Furaldehyde. Furfurylaldehyde

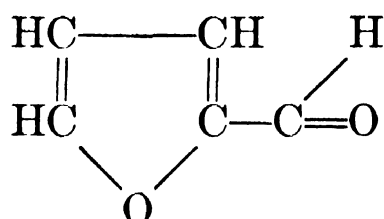

Occurrence.—Furfural occurs in the first fraction of many volatile oils belonging to the *Pinaceae* family—for example, in oil of *Pinus palustris*, in oil of cade, etc. It is present also in oil of orris root, lavender, Ceylon cinnamon, petitgrain, bay, clove, etc. Because of its solubility in water, furfural has been found in the distillation waters of oil of copal, cypress, savin, vetiver, orris root, Cayenne linaloe wood, West Indian sandalwood, ambrette seed, clove, clove stem, caraway, angelica, etc.

Isolation.—By washing the first fraction of the oil with water, extracting the water layer with ether, and evaporating the ether.

With sodium bisulfite in saturated aqueous solution, furfural forms an addition compound.

Identification.—Furfural can be characterized by the following methods:

(1) With aniline acetate, furfural gives an intense red color, while tetrahydrofurfural, methylfurfural, and hydroxymethylfurfural do not produce this color reaction.

(2) By the preparation of derivatives:

(a) With hydroxylamine hydrochloride in alkaline solution, furfural yields α -furfuraloxime m. 75° – 76° (from benzene and petroleum ether), according to Brady and Goldstein.¹ With hydroxylamine hydrochloride and sodium acetate in dilute alcohol, furfural yields β -furfuraloxime m. 91° – 92° (from alcohol).

(b) Phenylhydrazone m. 97° (uncorr.), prepared according to the following procedure of Huntress and Mulliken.²

In a dry test tube mix 1 drop of the oil to be tested with 2 drops of phenylhydrazine. Dissolve the pasty reaction product in 3 cc. of boiling 50% alcohol. Cool in running water, and shake until the precipitate separates. Collect on a small filter and wash with 5 cc. of cold 33% alcohol. Transfer to a test tube and redissolve in 5 cc. of boiling 33% alcohol. If dark droplets separate allow to settle and decant the clear hot solution. Cool, and shake until pearly crystals again precipitate. Filter and wash with cold 33% alcohol.

(c) *p*-Iodobenzoylhydrazone m. 235° (corr.), by Sah and Hsü.³

(d) Hydrazone from 1-methyl-3-carbohydrazidopyridinium *p*-toluene sulfonate m. 164° (corr.), by Allen and Gates.⁴

Properties.—Furfural is a colorless liquid which darkens rapidly on standing in light or air. Traces of pyrogallol retard this effect. The odor of furfural somewhat resembles that of benzaldehyde. The following properties have been reported by Evans and Aylesworth,⁵ Trimble,⁶ Mains,⁷ and Brühl:⁸

b.	161.7° ^{5,7}	n_D^{20}	1.5255 ⁶
b_{25}	64° – 65° ⁶		1.52608 ^{5,8}
d_{25}^{25}	1.1584 ⁶		
d_4^{20}	1.1594 ⁸		

Furfural is readily soluble in water (1 part furfural in 11 parts of water at 13° , 8.3 parts of furfural are soluble in 100 parts of water at 20°); soluble in alcohol or ether.

Furfural dissolves aromatic hydrocarbons in all proportions, while saturated aliphatic hydrocarbons exhibit only a limited solubility in furfural. Trimble⁹ studied the solubility of furfural and suggested the possibility of using it as an analytical reagent.

Easily volatile with steam. Furfural reduces Tollen's reagent and Fehling's solution and adds bromine.

Use.—Furfural and furfural derivatives are used for the compounding of a few types of synthetic essential oils.

- ¹ *J. Chem. Soc.* (1927), 1960.
- ² "Identification of Pure Organic Compounds," Order I (1941), 57. Cf. Mulliken, Vol. I (1904), 24.
- ³ *Rec. trav. chim.* **59** (1940), 349.
- ⁴ *J. Org. Chem.* **6** (1941), 599.
- ⁵ *Ind. Eng. Chem.* **18** (1926), 24.
- ⁶ *Ibid.* **33** (1941), 661.
- ⁷ *Chem. Met. Eng.* **26** (1922), 779.
- ⁸ *Liebigs Ann.* **235** (1886), 7.
- ⁹ *Ind. Eng. Chem.* **33** (1941), 660.

SUGGESTED ADDITIONAL LITERATURE

A. P. Dunlop, Paul R. Stout, and Samuel Swadesh, "Autoxidation of Furfural," *Ind. Eng. Chem.* **38**, No. 7, (1946), 705.

IV. KETONES

A. ALIPHATIC KETONES

Introduction.—Not many aliphatic ketones occur in volatile oils. The lowest members of this group originate most likely from decomposition of more complex compounds during steam distillation. Because of their solubility in water these ketones, particularly acetone and diacetyl, are found mainly in the distillation waters, or in the oils of cohobation obtained by redistillation (cohobation) of the distillation waters. Occasionally they also occur in the lowest fractions (foreruns) of the direct oils. Acetone and diacetyl are frequently accompanied by methyl alcohol and furfural.

(a) SATURATED ALIPHATIC KETONES.

Acetone

C_3H_6O

Mol. Weight 58.08

Dimethyl ketone



Occurrence.—Acetone has been observed in many essential oils, especially in those derived from leaf materials. Because of its solubility in water, this ketone can frequently be found in the distillation waters; occasionally it is accompanied by hydrocyanic acid. Quite possibly acetone originates during the distillation process through decomposition of more complex substances. Acetone thus occurs in oil of turpentine from *Abies excelsa*, in Russian turpentine oil, in Atlas cedar oil, in oil of clove, etc., in the distillation waters of American peppermint, of patchouly and numerous other plants.

Isolation.—By washing the first fraction of the distillate with water, separating the water-acetone mixture by fractionation, and purification with sodium iodide. Three mols of acetone and 1 mol of sodium iodide form an addition compound, which has been described by Shipsey and Werner,¹ Wadsworth and Dawson,² Macy and Thomas,³ and Weissberger and Proskauer.⁴ This ketone may likewise be isolated by means of its addition compound formed on treatment with a saturated aqueous solution of sodium bisulfite.

Identification.—(1) By color reaction:

Sodium nitroprusside test, according to Mulliken: ⁵

To 2 cc. of cold water add 5 drops of the oil to be tested, then 2 drops of a 1% aqueous solution of sodium nitroprusside, and finally 2 drops of 10% sodium hydroxide solution. Divide the solution in two parts, *a*- and *b*-, adding to the latter 3 drops of glacial acetic acid. Part *a*- is orange but changes to clear yellow in 20 min. Part *b*- on

acidification is red, with a slight tendency toward purple. This color does not change after 20 min. although the intensity slightly diminishes.

(2) By the preparation of derivatives:

(a) 2,4-Dinitrophenylhydrazone m. 128°, according to Allen.⁶

(b) *p*-Nitrophenylhydrazone m. 148°–149° (crystallized from alcohol), according to Dakin⁷ and Dehio.⁸

(c) *p*-Iodobenzoylhydrazone m. 214°–215° (corr.), by Sah and Hsü.⁹

(d) Hydrazone from *N*-methyl- β -carbohydrazidopyridinium *p*-toluene sulfonate m. 166° (corr.), by Allen and Gates.¹⁰

Properties.—Acetone is a water-clear liquid possessing a characteristic, peculiar, sweet odor. The following properties have been reported by Gilde-meister and Hoffmann,¹¹ Parks and Kelley,¹² Eisenlohr,¹³ and Bramley:¹⁴

m.	−95.6° ¹²	$d_4^{20.05}$	0.7912 ¹⁴
b.	56.5° ¹¹	d_{14}	0.79945 ¹¹
		$n_D^{19.4}$	1.35886 ¹³

Miscible in all proportions with water; soluble in alcohol, ether, etc.

When treated with iodine and potassium iodide solution and alkali, acetone yields iodoform.

Aside from other derivatives acetone forms an oxime and a phenylhydrazone, hydrazone, and methylphenylhydrazone that are not recommended for identification purposes because of their low melting points.

Use.—Acetone is widely used in the chemical industry as a solvent, as a reagent, and for organic synthesis.

¹ *J. Chem. Soc.* **103** (1913), 1255.

² *Ibid.* (1926), 2784.

³ *J. Am. Chem. Soc.* **48** (1926), 1547.

⁴ "Organic Solvents" (1925), Oxford University Press.

⁵ "Identification of Pure Organic Compounds," I (1904), 146.

⁶ *J. Am. Chem. Soc.* **52** (1930), 2957. Cf. Campbell, *Analyst* **61** (1936), 392.

⁷ *J. Biol. Chem.* **4** (1908), 238.

⁸ *Z. anal. Chem.* **104** (1936), 417.

⁹ *Rec. trav. chim.* **59** (1940), 352.

¹⁰ *J. Org. Chem.* **6** (1941), 599.

¹¹ "Die Ätherischen Öle," 3d Ed., Vol. I, 546.

¹² *J. Am. Chem. Soc.* **47** (1925), 2092.

¹³ *Z. Physik. Chem.* **75** (1911), 588.

¹⁴ *J. Chem. Soc.* **109** (1916), 41.

SUGGESTED ADDITIONAL LITERATURE

G. J. W. Ferrey, "Tests for Acetone and Ethyl Alcohol, with Special Reference to Methyl Alcohol," *Quart. J. Pharm. Pharmacol.* **18** (1945), 193. *Chem. Abstracts* **40** (1946), 1279.

***n*-Amyl Methyl Ketone**C₇H₁₄O

Mol. Weight 114.18

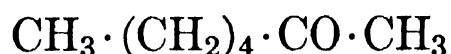
Methyl *n*-amyl ketone

Occurrence.—This ketone occurs in the low boiling fractions of clove oil and of Ceylon cinnamon oil. It contributes considerably to the odor of clove oil.

Isolation.—By fractional distillation and further purification through the sodium bisulfite addition compound, which this ketone forms with sodium bisulfite in saturated aqueous solution.

Identification.—Methyl *n*-amyl ketone can be characterized by the preparation of several derivatives:

(1) 2,4-Dinitrophenylhydrazone m. 89° (crystallized from alcohol), according to Allen.¹

(2) Semicarbazone m. 123° (crystallized from alcohol), according to Sherrill.²

Properties.—The following properties have been reported by Ginnings, Plonk and Carter,³ Gildemeister and Hoffmann,⁴ and Ceuterick:⁵

b.	151.2° ³	n _D ³⁰	1.40439 ⁵
	151°–152° ⁴	Sol.	Slightly soluble in water.
d ₄ ²⁵	0.8115 ³		Soluble in alcohol,
d ₄ ¹⁵	0.81966 ⁵		ether, etc. ⁴

Behal⁶ found that on oxidation with chromium trioxide and sulfuric acid, methyl *n*-amyl ketone yields *n*-valeric acid and acetic acid.

On reduction with sodium ethylate, methyl *n*-amyl ketone forms 2-heptanol, according to Whitmore and Otterbacher.⁷

Methyl *n*-amyl ketoxime is a liquid and, therefore, cannot be recommended as a derivative for identification purposes.

Use.—Methyl *n*-amyl ketone is used for the compounding of certain synthetic essential oils.

¹ *J. Am. Chem. Soc.* **52** (1930), 2957. [Cf. Campbell, *Analyst* **61** (1936), 394.]

² *Ibid.* 1990.

³ *Ibid.* **62** (1940), 1923.

⁴ "Die Ätherischen Öle," 3d Ed., Vol. I, 546.

⁵ *Bull. soc. chim. Belg.* **45** (1936), 555, 558.

⁶ *Ann. chim.* [6], **15** (1888), 271.

⁷ "Organic Syntheses," Coll. Vol. II (1943), 317.

Ethyl *n*-Amyl KetoneC₈H₁₆O

Mol. Weight 128.21

Amyl ethyl ketone. 3-Octanone

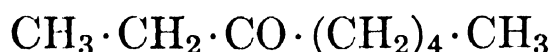

Occurrence.—Ethyl *n*-amyl ketone has been observed in the low boiling fractions of French lavender oil.

Isolation.—By fractional distillation; for purification the crude ketone is converted into the semicarbazone which, on decomposition with 10% sulfuric acid and steam distillation, yields the pure ketone.

Identification.—Through the semicarbazone m. 117°–117.5°, according to Schimmel & Co.;¹ m. 112° (slow heating), according to Pickard and Kenyon.²

On oxidation with chromic acid, ethyl *n*-amyl ketone yields caproic acid b. 203°–206°, according to Schimmel & Co.³

Ethyl *n*-amyl ketone is a mobile liquid with a characteristic, strong and somewhat fruity odor.

Properties.—The following properties have been reported by Schimmel & Co.:⁴

b ₇₅₄	169.5°–170°
d ₁₅ ¹⁵	0.8251
n _D ²⁰	1.41536

Ethyl *n*-amyl ketone is volatile with steam. It does not react with sodium bisulfite.

On treatment with hydroxylamine, ethyl *n*-amyl ketone forms an oxime b₅ 91°, according to Schimmel & Co.⁵

Use.—Ethyl *n*-amyl ketone is occasionally used for the compounding of certain synthetic essential oils.

¹ *Ber. Schimmel & Co.* April (1903), 42; Oct. (1903), 43.

² *J. Chem. Soc.* **103** (1913), 1936.

³ *Ber. Schimmel & Co.* April (1903), 42; Oct. (1903), 43.

⁴ *Ibid.*

⁵ *Ibid.*

Methyl *n*-Heptyl KetoneC₉H₁₈O

Mol. Weight 142.23

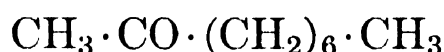
n-Heptyl methyl ketone. 2-Nonanone

Occurrence.—Methyl *n*-heptyl ketone forms the principal constituent of rue oils distilled mainly from *Ruta bracteosa* (“winter rue”), and *R. angustifolia* Pers.; in smaller amounts it occurs in rue oils derived from *R. montana* L. (“summer rue”), and *R. graveolens* (“garden rue”). This ketone has been

identified also in the volatile coconut oil, in oil of clove, and in a few other essential oils.

Isolation.—By fractional distillation and purification through the sodium bisulfite addition compound.

Identification.—Methyl *n*-heptyl ketone can be characterized by the preparation of its semicarbazone m. 118°–119° (crystallized from alcohol), according to Dakin;¹ or m. 119°–120°, according to Stärkle,² and Ruzicka and Brugger.³

Properties.—The following properties have been reported by Ceuterick,⁴ Deffet,⁵ Ruzicka and Brugger,⁶ Power and Lees,⁷ and Houben:⁸

m.	−8.2° ⁵	d_4^{22}	0.8188 ⁶
b.	195.3° ⁵	d_4^{15}	0.82537 ⁴
b_{15}	80°–82° ⁸	d_{16}^{14}	0.8296 ⁷
b_{12}	75°–77° ⁶	n_D^{22}	1.4175 ⁶

Methyl *n*-heptyl ketone is insoluble in water, soluble in alcohol, etc.

Reducing methyl *n*-heptyl ketone with metallic sodium and alcohol, Thoms and Mannich⁹ obtained *n*-methylheptylcarbinol b. 193°–194°, which, according to Adamson and Kenner,¹⁰ can be characterized by the preparation of its α -naphthylurethane m. 55.5° (crystallized from petroleum ether).

Oxidizing methyl *n*-heptyl ketone with chromium trioxide, van Gysegem¹¹ obtained acetic acid and *n*-heptylic acid.

Use.—Methyl *n*-heptyl ketone is used for the compounding of certain synthetic (artificial) essential oils.

¹ *Am. Chem. J.* **44** (1910), 46. See also Gildemeister and Hoffmann, "Die Ätherischen Öle," 3d Ed., Vol. I, 547.

² *Biochem. Z.* **151** (1924), 384.

³ *Helv. Chim. Acta* **9** (1926), 353.

⁴ *Bull. soc. chim. Belg.* **45** (1936), 564.

⁵ *Ibid.* **40** (1931), 391.

⁶ *Helv. Chim. Acta* **9** (1926), 353.

⁷ *J. Chem. Soc.* **81** (1902), 1588.

⁸ *Ber.* **35** (1902), 3588.

⁹ *Ber.* **36** (1903), 2548.

¹⁰ *J. Chem. Soc.* (1934), 842.

¹¹ *Chem. Zentr.* I (1907), 530.

Methyl *n*-Nonyl Ketone

$C_{11}H_{22}O$

Mol. Weight 170.29

2-Undecanone

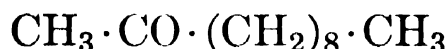

Occurrence.—Methyl *n*-nonyl ketone is the main constituent of rue oils distilled mainly from *Ruta montana* L. ("summer rue") and *R. graveolens* ("garden rue"), whereas in the rue oils derived from *R. bracteosa* ("winter rue") this ketone plays only a subordinate role, methyl heptyl ketone predominating.

Isolation.—By fractional distillation and purification through the sodium bisulfite addition compound which this ketone forms with sodium bisulfite in saturated aqueous solution.

Identification.—Methyl *n*-nonyl ketone can be characterized by the preparation of several derivatives:

(1) 2,4-Dinitrophenylhydrazone m. 63° (from alcohol), according to Allen.¹

(2) Hydrazone from *N*-methyl- β -carbohydrazidopyridinium *p*-toluene sulfonate m. 110°, by Allen and Gates.²

Properties.—Methyl nonyl ketone is liquid at room temperature; its odor resembles that of methyl heptyl ketone. The following properties have been reported by Timmermans,³ Ceuterick,⁴ Thoms,⁵ Houben,⁶ Carette,⁷ and Power and Lees:⁸

cong. pt.	12° ⁵	d_4^{20}	0.8260–0.8263 ^{5,6}
m.	12.1° ³	d_{15}	0.8295 ⁶
	12.7° ⁴	n_D^{30}	1.42527 ⁴
b ₇₆₆	230.65° ⁷ (corr.)		
b ₇₆₁	231.5°–232.5° ⁸ (after regeneration from semicarbazone)		
b ₂₄	122°–123° ⁷ (corr.)		
b ₂₀	120° ⁶		
b ₁₈	118° ⁶		
b ₇	99° ⁵		

On oxidation with chromium trioxide, methyl *n*-nonyl ketone yields pelargonic acid and acetic acid.

Use.—Methyl *n*-nonyl ketone is used in the compounding of certain synthetic (artificial) essential oils.

¹ *J. Am. Chem. Soc.* **52** (1930), 2957. Cf. Campbell, *Analyst* **61** (1936), 394.

² *J. Org. Chem.* **6** (1936), 599.

³ *Bull. soc. chim. Belg.* **31** (1922), 391.

⁶ *Ber.* **35** (1902), 3590.

⁴ *Ibid.* **45** (1936), 558.

⁷ *J. pharm. chim.* II, **10** (1899), 256.

⁵ *Ber. deut. pharm. Ges.* **11** (1906), 8.

⁸ *J. Chem. Soc.* **81** (1902), 1588.

Methyl *n*-Undecyl Ketone

C₁₃H₂₆O

Mol. Weight 198.34

Undecyl methyl ketone. 2-Tridecanone

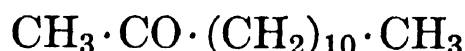

Occurrence.—This ketone has been found in the fraction b. 260°–265° of ethereal coconut oil by Haller and Lassieur,¹ likewise in the essential oil of “Matsubasa” (*Schizandra nigra*, maxim.) by Sengoku.²

Isolation.—By fractional distillation or through the bisulfite addition compound which forms but slowly from sodium bisulfite and is decomposed by sodium carbonate. Subsequent recrystallization is recommended in either case.

Identification.—Methyl *n*-undecyl ketone can be characterized by the preparation of several derivatives, but the following are recommended:

- (1) 2,4-Dinitrophenylhydrazone m. 69° (Allen ³).
- (2) *p*-Nitrophenylhydrazone m. 101° – 102° , according to Sengoku.⁴
- (3) Oxime m. 56° – 57° (crystallized from alcohol and petroleum ether), by Guérin ⁵ and Sengoku.⁶

Properties.—Methyl *n*-undecyl ketone is a crystalline mass. The following properties have been reported by Ceuterick,⁷ Haller and Lassieur,⁸ Krafft,⁹ Guérin,¹⁰ Pickard and Kenyon,¹¹ and Dreger et al.:¹²

m.	29° ^{8,11}	d_4^{30}	0.82168 ⁷
	30.5° ¹²	n_D^{30}	1.43175 ⁷
b.	263° ⁹		
b_{14-15}	140° – 142° ¹⁰		
$b_{5.5}$	127.7° ¹²		

On oxidation with potassium dichromate and dilute sulfuric acid, methyl *n*-undecyl ketone gives, according to Krafft,¹³ a quantitative yield of acetic acid and undecylic acid.

Use.—Natural methyl *n*-undecyl ketone is not used in our industries.

- ¹ *Compt. rend.* **151** (1910), 699.
- ² *J. Pharm. Soc. Japan* **53** (1933), 947.
- ³ *J. Am. Chem. Soc.* **52** (1930), 2957.
- ⁴ *Chem. Zentr.* I (1934), 235.
- ⁵ *Bull. soc. chim.* [3], **29** (1903), 1130.
- ⁶ *Chem. Zentr.* I (1934), 235.
- ⁷ *Bull. soc. chim. Belg.* **45** (1936), 558.
- ⁸ *Compt. rend.* **151** (1910), 699.
- ⁹ *Ber.* **12** (1879), 1667; **15** (1882), 1724.
- ¹⁰ *Bull. soc. chim.* [3], **29** (1903), 1130.
- ¹¹ *J. Chem. Soc.* **99** (1911), 57.
- ¹² *Ind. Eng. Chem.* **36** (1944), 612.
- ¹³ *Ber.* **12** (1879), 1667.

Diacetyl



Mol. Weight 86.09

Biacetyl. Dimethylglyoxal

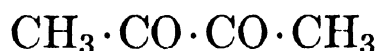

Occurrence.—Like methyl alcohol and furfural, this aliphatic diketone occurs in the foreruns of numerous volatile oils and, due to its solubility in water, also in the distillation waters. Thus, diacetyl has been identified in oil of cypress, savin, vetiver root, orris root, West Indian sandalwood, bay, caraway, angelica root, etc.

Isolation.—By fractional distillation. For purification purposes Olivier¹ suggested treatment with 2 mols of phosphoric acid whereby a crystalline addition product ($C_4H_6O_2 \cdot 2H_3PO_4$) is formed from which diacetyl can be regenerated by the addition of water. Treatment with excess phosphoric acid results in the formation of a liquid product.

Identification.—Much work has been done on the qualitative detection of diacetyl, if present in small quantities, and on the quantitative assaying of this diketone. Diacetyl can be characterized by several methods:

(1) By the preparation of diacetyldioxime (dimethylglyoxime): 1 mol of diacetyl on treatment with 2 mols of hydroxylamine hydrochloride and 1 mol of sodium carbonate in aqueous solution yields, according to Fittig, Daimler and Keller,² a dioxime which (crystallized from dilute alcohol) melts at 234.5° (with sublimation). Biltz³ reported the sublimed product to melt at 245° – 246° (corr.).

The diacetyldioxime (dimethylglyoxime) yields colored complex salts with metals, which reactions have been suggested by various investigators for the quantitative determination of diacetyl. Prill and Hammer⁴ developed a colorimetric method for the micro determination of diacetyl as diamino-ferrous dimethylglyoximate. Van Niel⁵ suggested a quantitative method for the determination of diacetyl and acetyl-methylcarbinol. Schmalfluss and co-workers⁶ made extensive studies on the detection of diacetyl in food products. For example, they described a method for the assaying of diacetyl as nickel salt of dimethylglyoxime with an average error of $\pm 0.2\%$. These procedures permit the exact quantitative determination of diacetyl even in presence of other volatile α -dicarbonyl compounds.

(2) Diacetyl bis-semicarbazone m. 278° – 279° (crystallized from glacial acetic acid), according to Posner.⁷ Diacetyl mono-semicarbazone m. 235° (corr.) (crystallized from water or glacial acetic acid), according to Biltz⁸ and Diels.⁹

(3) Bis-2,4-dinitrophenylhydrazone m. 314° – 315° (crystallized from nitrobenzene), according to Strain.¹⁰

Properties.—Diacetyl is a yellowish liquid with a diffusive odor, in dilution somewhat reminiscent of butter. Because of its high vapor pressure, diacetyl rapidly vaporizes at room temperature; a drop of diacetyl when put on testing paper disappears within a few minutes.

The following properties have been reported (cf. Olivier,¹¹ von Auwers,¹² and Gildemeister and Hoffmann¹³):

m.	-2.4° ¹¹
b_{750}	88° – 89° ¹¹
d_4^{20}	0.975 ¹²
d_{22}	0.9734 ¹³
$d_4^{13.45}$	0.9809 ¹²
d_{15}^{15}	0.9904 ¹¹
$n_D^{13.45}$	1.39525 ¹²

Diacetyl is soluble in 4 parts of water at room temperature, miscible with alcohol, or ether, etc. Diacetyl readily adds sodium bisulfite. When allowed to stand for several days at 0° with concentrated hydrochloric acid,

diacetyl, according to Diels and Jost,¹⁴ yields a precipitate which is a trimer of diacetyl, white crystals m. 105°.

Use.—Diacetyl is used for the compounding of artificial butter flavors; it serves also in all kinds of synthetic fruit flavors to which it imparts, if carefully dosed, a smooth butter-like note modifying thereby the harsh odor of synthetic aromatics.

¹ *Bull. soc. chim.* [4], **51** (1932), 100, 105.

² *Liebigs Ann.* **249** (1888), 204.

³ *Ber.* **41** (1908), 1881.

⁴ *Iowa State Coll. J. Sci.* **12** (1938), 377.

⁵ *Biochem. Z.* **187** (1927), 472.

⁶ *Z. Untersuch. Lebensm.* **63** (1932), 283; **70** (1935), 233; **76** (1938), 113. *Fette u. Seifen* **44** (1937), 509. *Chem. Abstracts* **32** (1938), 4677.

⁷ *Ber.* **34** (1901), 3977.

⁸ *Ber.* **41** (1908), 1881.

⁹ *Ber.* **35** (1902), 348.

¹⁰ *J. Am. Chem. Soc.* **57** (1935), 760.

¹¹ *Bull. soc. chim.* [4], **51** (1932), 100, 105.

¹² *Ber.* **51** (1918), 1119.

¹³ "Die Ätherischen Öle," 3d Ed., Vol. I, 548.

¹⁴ *Ber.* **35** (1902), 3294.

(b) UNSATURATED ALIPHATIC KETONES.

Methyl Heptenone

C₈H₁₄O

Mol. Weight 126.19

2-Methyl-1-hepten-6-one

2-Methyl-2-hepten-6-one

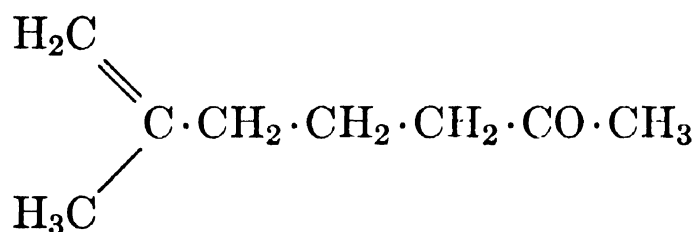

α -Methyl heptenone

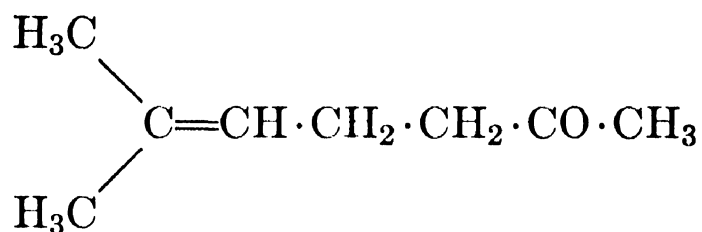

β -Methyl heptenone

Occurrence.—This aliphatic ketone, containing one ethylenic linkage, occurs in several volatile oils—for example, in oil of lemon, lemongrass, citronella, palmarosa, Mexican linaloe, and is often accompanied by related compounds such as linaloöl, geraniol and citral.

According to Wallach,¹ the naturally occurring methyl heptenone consists of several isomers which he designated α -, β -, γ - and δ -methyl heptenone. Later workers suggested the terms α - and β -methyl heptenone which forms correspond to citral *a* and citral *b*. Grignard, Dœuvre and Escourrou² came to the conclusion that the natural methyl heptenone occurring in lemongrass oil consists of a mixture of α - and β -methyl heptenone, containing at the most 25 per cent of the α - form, but these data must await quantitative chemical determinations on samples of known purity.

Isolation.—From the fractions b. 160° – 180° of an essential oil by the preparation of the bisulfite compound and by regeneration of the parent ketone.

Identification.—Methyl heptenone is readily recognized by its characteristic fruity odor, reminiscent of amyl acetate. The ketone can be identified through several derivatives:

(1) According to Tiemann and Krüger,³ methyl heptenone forms a semicarbazone which, although probably a mixture of isomers, melts uniformly provided the semicarbazone is prepared as follows:

Add a solution of 12 g. of semicarbazide hydrochloride and 15 g. of sodium acetate in 20 cc. of water to a mixture of 12 g. of methyl heptenone and 20 cc. of glacial acetic acid. Set aside the mixed solutions for about one-half hour. On addition of water, the semicarbazone will separate as an oil which soon congeals to crystals. Recrystallized from dilute alcohol, the semicarbazone melts at 136° – 138° .

(2) According to Neuberg and Lewite,⁴ methyl heptenone can also be characterized by the preparation of the *p*-nitrophenylhydrazone which crystallizes in the form of light yellow needles m. 103.5° – 104° .

Allen⁵ prepared the 2,4-dinitrophenylhydrazone m. 81° , and Strain⁶ the *m*-nitrobenzohydrazone m. 99° – 100° .

(3) In order to identify methyl heptenone in the presence of citronellal and citral, Tiemann⁷ suggested taking advantage of the fact that methyl heptenone does not react with either a dilute or a concentrated solution of sodium sulfite and sodium bicarbonate, and that the two aldehydes can be removed successively by shaking the oily mixture with the respective solutions of these salts.

Properties.—Methyl heptenone is a colorless, mobile oil, optically inactive and possessing a peculiar characteristic fruit-like odor. The physicochemical properties vary according to the origin of the ketone.

The natural isolates seem to yield slightly lower characteristics than the synthetic product. Timmermans,⁸ von Rechenberg,⁹ Schimmel & Co.,¹⁰ and Escourrou¹¹ found these properties typical of a stable methyl heptenone:

m.	-67.1° ⁸	d_{15}^{15}	0.8656 ¹⁰
b.	173° – 174° ^{9,10,11}	d_{10}	0.8691 ¹¹
b_{100}	108.3° ⁹	n_D^{14}	1.44345 ¹¹
		n_D^{10}	1.4455 ¹¹

α -Methyl heptenone (δ -methyl heptenone of Wallach) boils at 168° (Verley¹²). Escourrou¹³ found that, on heating with alkali, α -methyl heptenone is transformed into the β - form. When oxidized, the α - form yields only traces of acetone.

β -Methyl heptenone (γ -methyl heptenone of Wallach) boils at 173° – 174° . On oxidation it yields the theoretical quantity of acetone.

Use.—Methyl heptenone is used as an adjunct in the scenting of soaps and all kinds of technical preparations.

¹ *Liebigs Ann.* **408** (1915), 183.

² *Compt. rend.* **177** (1923), 669. See also Escourrou, *Bull. soc. chim.* [4], **43** (1928), 1088; and Dupont, Desreux and Dulou, *Bull. soc. chim.* [5], **4** (1937), 2023.

- ³ *Ber.* **28** (1895), 2124.
⁴ *Biochem. Z.* **91** (1918), 266.
⁵ *J. Am. Chem. Soc.* **52** (1930), 2955.
⁶ *Ibid.* **57** (1935), 758.
⁷ *Ber.* **32** (1899), 823.
⁸ *Bull. soc. chim. Belg.* **36** (1927), 506.
⁹ *Z. physik. Chem.* **95** (1920), 168.
¹⁰ *Ber. Schimmel & Co.*, April (1912), 173.
¹¹ *Bull. soc. chim.* [4], **39** (1926), 1125.
¹² *Rev. prod. chim.* **21** (1918), 352. *Chem. Zentr.* I (1919), 922.
¹³ *Bull. soc. chim.* [4], **39** (1926), 1125.

2,6-Dimethyl-7-octen-4-one

C₁₀H₁₈O

Mol. Weight 154.24

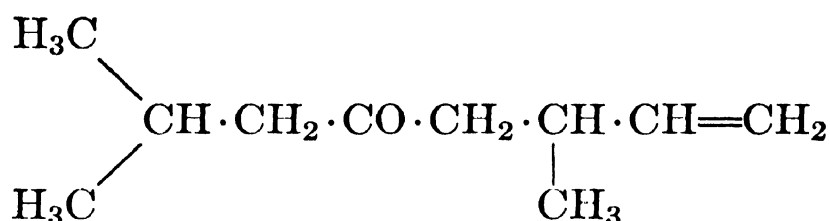

Occurrence.—Jones and Smith¹ found this unsaturated ketone in the oil distilled from the flowers of *Tagetes glandulifera*.

Identification.—The ketone can be characterized by the preparation of its crystalline semicarbazone m. 92.5° (from alcohol).

The oxime is an oil:

b.	222°
d _{15.5}	0.8778
[α] _D	+2° 24'

Properties.—When purified through its crystalline semicarbazone, the ketone has these properties:

b.	185°–186°	[α] _D	+1° 30'
d _{15.5}	0.8354	n _D ²⁰	1.4295

This ketone shows no tendency toward cyclization, does not react with sulfuric acid (20 per cent), and does not combine with sodium sulfite or sodium bisulfite.

Use.—2,6-Dimethyl-7-octen-4-one is not used in our industries.

¹ *J. Chem. Soc.* **127** (1925), 2530.

Tagetone

C₁₀H₁₆O

Mol. Weight 152.23

2-Methyl-6-methylene-7-octen-4-one

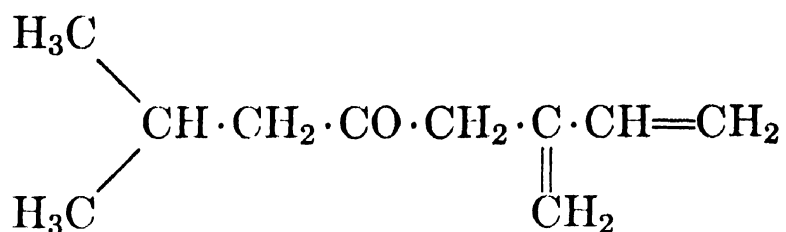

Occurrence.—Jones and Smith¹ found tagetone in the highest boiling fractions of tagetes oil (*Tagetes glandulifera*). Jones,² however, besides demonstrating the presence of a second ketone (Me)₂:CH·CH₂·CO·CH₂·CH(Me)·CH=CH₂ along with tagetone in this essential oil, modified the original formula so as to regard tagetone as represented by this tautomeric system:

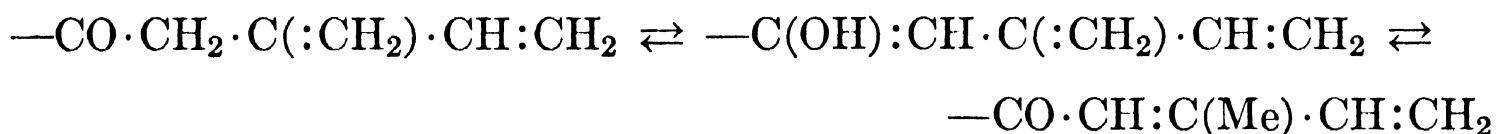

Isolation.—By fractional distillation of tagetes oil *in vacuo*. Tagetone shows a distinct tendency toward resinification, probably due to the fact that the ketone may exist also in enolic form. Because of this tendency, tagetone is difficult to obtain in a pure state.

Identification.—No crystalline derivatives of tagetone have been described. The semicarbazone is resinous, the oxime an oil b₂₅ 126°, d_{15.5} 0.9207, n_D²⁰ 1.4820.

However, Jones and Smith³ have demonstrated that catalytic reduction yields a saturated ketone 3,7-dimethyl-octan-5-one which forms a semicarbazone m. 91.5°–92.5°.

Properties.—Tagetone is a yellowish oil which, on standing, resinifies and becomes viscid. According to Jones and Smith,⁴ tagetone has these properties:

b.	∞ 205°–210°	d _{15.5}	0.8803
b ₃₋₄	62°	n _D ²⁰	1.4895

On oxidation with potassium permanganate in alkaline solution, tagetone yields isovaleric and oxalic acids; when treated with potassium hydroxide in alcoholic solution, tagetone forms methyl isobutyl ketone. Tagetone does not show any tendency toward cyclization.

Use.—Tagetone, as such, is not used in our industries.

¹ *J. Chem. Soc.* **127** (1925), 2530, 2538.

² *Proc. Roy. Soc. Queensland* **45** (1934), 45.

³ *J. Chem. Soc.* **127** (1925), 2532.

⁴ *Ibid.* 2538.

The Tagetenones

C₁₀H₁₄O

Mol. Weight 150.21

According to Naves,¹ the tagetenones consist of a mixture of

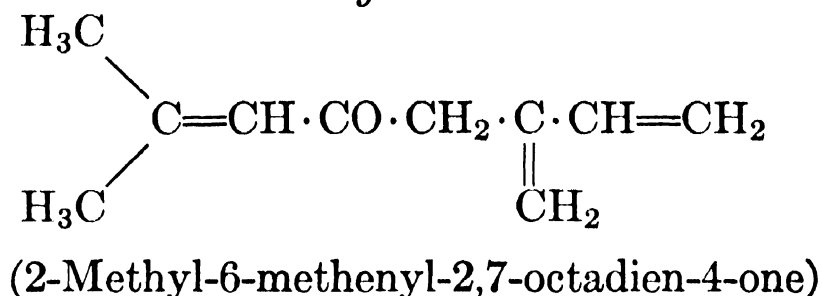
Myrcenone

and

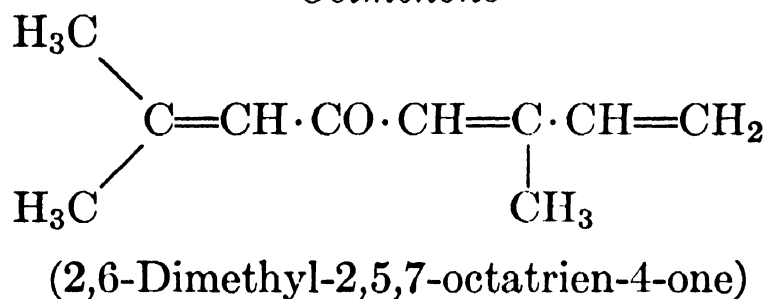
Ocimenone

and

perhaps isopropylidenic (α) isomers

Occurrence.—Naves² identified the tagetenones in the volatile oil of *Lippia asperifolia* Rich. (syn. *Lantana lavandulacea* Willd.) which contains 80 per cent of this ketone mixture.

Isolation.—By fractional distillation *in vacuo*.

Identification.—By hydrogenation to the saturated ketone 2,6-dimethyl-4-octanone b. 187°–188°, d_4^{20} 0.8155, n_4^{20} 1.41952, which can be characterized by the preparation of its semicarbazone m. 92°–92.5° (crystallized from pentane), and of its phenyl-4-semicarbazone m. 95.5–96° (crystallized from methanol).

Properties.—Naves³ reported these properties:

b _{2.1}	63°–64°
d_4^{20}	0.9033
n_D^{20}	1.5003

The tagetenones are volatile with steam, and soluble in alcohol and ether. To be quantitative, the oximation must be effected in a neutral medium (CaCO₃), and by refluxing with alcohol for 1 hr.

When boiled with 70 per cent sulfuric acid for 2 hrs., the mixture of ketones yields an abundance of acetone.

Use.—The tagetenones, as such, are not used in our industries.

¹ Private communication of Dr. Y. R. Naves, Geneva, during publication of this book. Cf. *Helv. Chim. Acta* **31** (1948), 29.

² *Ibid.*

³ *Ibid.*

Artemisia Ketone

and

Isoartemisia Ketone

 $C_{10}H_{16}O$

Mol. Weight 152.23

2,5,5-Trimethyl-1,6-heptadien-4-one

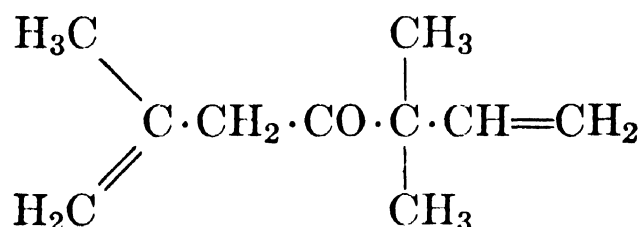

and

2,5,5-Trimethyl-2,6-heptadien-4-one

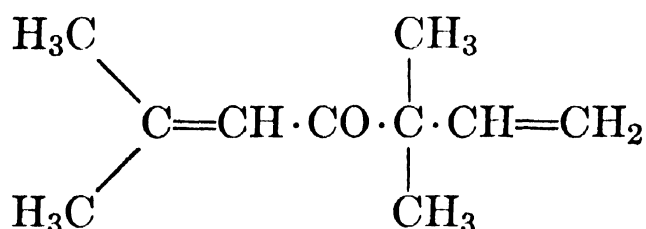

This ketone is of interest as it represents one of the few exceptions to the "isoprene rule" being built up from irregularly assembled isoprene units.

Occurrence.—These acyclic ketones containing two ethylenic linkages were observed by Imada,¹ by Asahina and Yoshitomi,² and by Asahina and Takagi³ in oil of *Artemisia annua* L.

Isolation.—By fractional distillation of the oil, preparation of the semicarbazones, and regeneration of the ketones through hydrolysis of the semicarbazones.

Identification.—The ketones each yield a semicarbazone, which can be separated by fractional crystallization.

Artemisia ketone forms the more sparingly soluble semicarbazone m. 95°–96°, whereas the semicarbazone of isoartemisia ketone m. 70°–72° is more soluble. The latter contains water of crystallization; in anhydrous form the semicarbazone of isoartemisia ketone melts at 103°–104°. Upon heating artemisia ketone semicarbazone with 20% sulfuric acid, the azide (m. 156°) is formed.

Properties.—Regenerated from their semicarbazones, the two ketones, which are optically inactive, possess these properties:

<i>Artemisia ketone</i>		<i>Isoartemisia ketone</i>	
b.	182°	b.	182°–183°
d_4^{14}	0.8906	d_4^{17}	0.8711
$n_D^{18.5}$	1.4695	n_D	1.4188

Asahina and Takagi ⁴ found that both ketones, when hydrogenated catalytically, yield the same tetrahydro ketone, viz., 2,5,5-trimethylheptan-4-one.

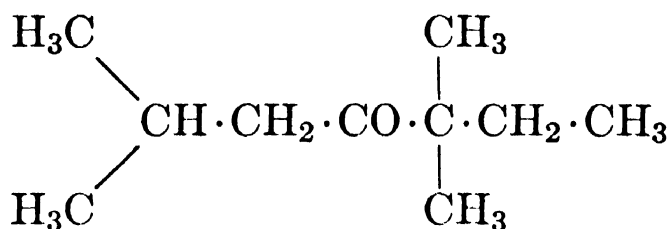

Ruzicka, Reichstein and Pulver ⁵ synthesized a tetrahydro artemisia ketone and demonstrated its identity with the tetrahydro derivative derived from the natural isolate to confirm the structure originally proposed by Asahina and Takagi.

Use.—These ketones are not used in our industries.

¹ *J. Pharm. Soc. Japan* No. 420 (1917), 119.

² *Ibid.* No. 424 (1917), 1.

³ *Ibid.* No. 464 (1920), 837. *Helv. Chim. Acta* 20 (1937), 220.

⁴ *J. Pharm. Soc. Japan* No. 464 (1920), 837.

⁵ *Helv. Chim. Acta* 19 (1936), 646.

SUGGESTED ADDITIONAL LITERATURE

Jean Colonge and Pierre Dumont, "Synthesis and Cyclization of Artemisia Ketone," *Compt. rend.* 220 (1945), 500. *Chem. Abstracts* 40 (1946), 4684.

Doremone

$\text{C}_{15}\text{H}_{26}\text{O}$

Mol. Weight 222.36

The constitution of this first acyclic sesquiterpene ketone found in nature has not been definitely established. Doremone contains two ethylenic linkages.

Occurrence.—Semmler, Jonas and Roenisch ¹ isolated doremone from ammoniacum oil (*Dorema ammoniacum* Don.).

Isolation.—By repeated fractionation.

Identification.—Doremone can be characterized:

(1) by the preparation of the semicarbazone m. 124°.

(2) by the preparation of the oxime m. 88°.

Properties.—Doremone is an oil possessing these properties:

b_{12}	145°–155°	α_{D}^{20}	+3° 30'
d_{20}	0.8765	n_{D}^{20}	1.47160

On reduction with sodium and alcohol, doremone yields doremol, an aliphatic alcohol $\text{C}_{15}\text{H}_{28}\text{O}$, b_{12} 145°–150°, d_{20} 0.8702, α_{D}^{20} +3° 0', n_{D}^{20} 1.47130.

The acetate of doremol, b_{12} 155° – 165° , d_{20} 0.8896, α_D^{20} $+4^{\circ} 48'$, n_D^{20} 1.46596 also seems to occur in ammoniacum oil.

Use.—Doremone is not used in our industries.

¹ *Ber.* **50** (1917), 1829.

SUGGESTED ADDITIONAL LITERATURE

Henri Leclerc, "The Pharmacology of Gum Ammoniac (*Diserneston gummiferum* Jaub. and Spach.)," *Bull. sci. pharmacol.* **48** (1941), 81. *Chem. Abstracts* **36** (1942), 1140.

B. CYCLIC TERPENE KETONES

(a) MONOCYCLIC TERPENE KETONES.

Cryptone

$C_9H_{14}O$

Mol. Weight 138.20

4-Isopropyl-2-cyclohexen-1-one

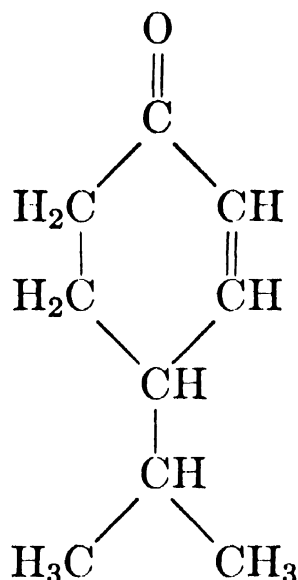

According to Berry, Macbeth and Swanson,¹ the aldehyde *l*-cryptal described earlier by Penfold,² and Penfold and Simonsen,³ as a constituent of various eucalyptus oils is actually *l*-cryptone. Cryptal, in the opinion of Berry et al., does not occur in nature.

Occurrence.—Cryptone, in laevorotatory form, was first observed by Cahn, Penfold and Simonsen⁴ in the oils of *Eucalyptus polybractea*, *E. hemiphloia*, and *E. cneorifolia*. Shortly thereafter, Berry, Macbeth and Swanson⁵ and, working independently, Wienhaus and Striegler,⁶ found the dextrorotatory form of 4-isopropyl-2-cyclohexen-1-one in water fennel oil (*Phellandrium aquaticum* L.).

Isolation.—*l*-Cryptone has been isolated:

(1) Through the hydrosulfide m. 206° – 207° , by Hooper, Macbeth and Price.⁷ From this hydrogen sulfide compound the ketone can be regenerated by the action of mercuric chloride in ether.

(2) Through the semicarbazone m. 185° (with decomposition) by Cahn, Penfold and Simonsen.⁸

Identification.—*l*-Cryptone may be characterized by the preparation of several derivatives:

(1) Hydrosulfide compound (see above).

(2) Semicarbazone (see above).

(3) *p*-Nitrophenylhydrazone m. 168° – 169° , according to Cahn, Penfold and Simonsen.⁹

(4) Galloway, Dewar and Read¹⁰ reported that the 2,4-dinitrophenylhydrazone of optically pure *l*-cryptone melts at 132° , while Hooper, Macbeth and Price¹¹ found m. 137.5° – 138° .

Properties.—Cahn, Penfold and Simonsen¹² reported these properties of *l*-cryptone from the eucalyptus oils:

b_{10}	98° – 100°	α_D	$-59^{\circ} 18'$ to $-66^{\circ} 24'$
d_{15}^{15}	0.9472 to 0.9483	n_D^{20}	1.4820 to 1.4848

The optically pure ketone prepared by Galloway, Dewar and Read¹³ had these properties:

b_9	90°
$[\alpha]_D$	$-119^{\circ} 18'$ ($c = 2$ in alc.)
n_D^{18}	1.4810

Isolating cryptone from the oil of *Eucalyptus cneorifolia* by means of the neutral sulfite method—continuous shaking from 2 to 3 hr. with a 35 per cent $\text{Na}_2\text{SO}_3 \cdot 7\text{H}_2\text{O}$ solution, and liberation of the cryptone by treatment with caustic soda solution in the presence of ether—Berry¹⁴ obtained a cryptone:

$d_{15.5}^{15.5}$	0.927 to 0.966
$[\alpha]_D$	$-55^{\circ} 36'$ to $-68^{\circ} 48'$

On oxidation with potassium permanganate, cryptone yields α -isopropylglutaric acid.

Use.—Cryptone is not used in our industries.

¹ *J. Chem. Soc.* (1937), 986, 1443.

² *Ibid.* **121** (1922), 266. *J. Proc. Roy. Soc. New South Wales* **61** (1927), 185.

³ *J. Chem. Soc.* (1930), 403.

⁴ *Ibid.* (1931), 1366.

⁵ *Ibid.* (1937), 1448.

⁶ *Ber. Schimmel & Co.* (1937), 91.

⁷ *J. Chem. Soc.* (1934), 1149.

⁸ *Ibid.* (1931), 1366.

⁹ *Ibid.*

¹⁰ *Ibid.* (1936), 1595.

¹¹ *Ibid.* (1934), 1147.

¹² *Ibid.* (1931), 1366.

¹³ *Ibid.* (1936), 1595.

¹⁴ *Australian Chem. Inst. J. and Proc.* **14** (1947), 173.

Menthone

 $C_{10}H_{18}O$

Mol. Weight 154.24

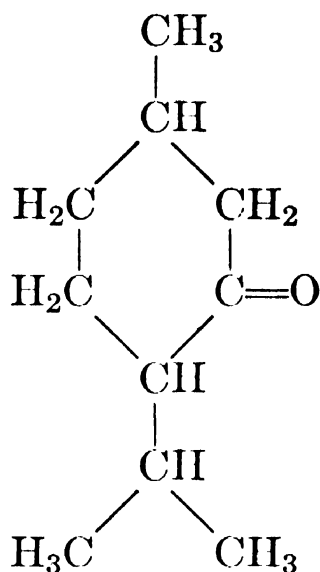
p-Menthane-3-one. 1-Methyl-4-isopropylcyclohexan-3-one

Because of its two asymmetric carbon atoms, menthone can exist in two racemic and four optically active modifications that have come to be recognized as

<i>d</i> -menthone	<i>d</i> -isomenthone
<i>l</i> -menthone	<i>l</i> -isomenthone
<i>dl</i> -menthone	<i>dl</i> -isomenthone

This molecule, by virtue of its configuration, also allows geometrical isomerism that has been the subject of comparatively recent study by Sugden and Whitaker,¹ Zeitschel and Schmidt,² Read, Robertson and Cook,³ Read,⁴ Hiraidzumi,⁵ Gillespie, Macbeth and Mills,⁶ Weissberger⁷ and others, and readily accounts for the existence of certain characteristics of the menthone-isomenthone series.

Menthone occurs frequently as a mixture of several modifications which are difficult to separate and which are easily inverted by the action of acids or bases, causing a change in the rotatory power of the substance.

Occurrence.—*d*-Menthone has been found in oil of *Nepeta japonica* and *Barosma pulchella*.

l-Menthone occurs in oil of pennyroyal, peppermint (up to 30 per cent), buchu leaf, *Calamintha nepeta*, etc. According to Schimmel & Co.,⁸ Réunion geranium oil does not contain *l*-menthone, as formerly assumed, but *l*-isomenthone. Schimmel & Co. developed a method of identifying these two ketones in mixtures.

d-Isomenthone has been identified in Portuguese and Moroccan pennyroyal oil by Navcs.⁹

l-Isomenthone has been isolated by Angla¹⁰ from Algerian oil of geranium. Goethals¹¹ reported this isomer in geranium oil from the Belgian Congo, even as much as 75 per cent in an oil from Katanga.

Isolation.—Menthone cannot be isolated and freed from accompanying substances by mere fractional distillation; neither does menthone react easily with bisulfites. Therefore, Schindelmeiser¹² suggested isolating menthone most conveniently from mixtures through its oxime or semicarbazone. For example, oil of peppermint is fractionated and from the fraction b. 204°–212° the oxime or semicarbazone prepared. Menthone may be regenerated therefrom by decomposing the oxime or semicarbazone with dilute sulfuric acid. Read and Cook¹³ have found these derivatives most suitable for readily distinguishing *dl*-menthone and *dl*-isomenthone by preparation in weakly acid solutions. The rotatory power of the regenerated ketone may be changed, depending on the procedure used (in this connection, see Weissberger et al.¹⁴). However, Kon¹⁵ in 1930 cited a method which prevents this isomerization of sensitive ketones during regeneration; in this procedure hydrolysis is carried out in a petroleum ether (b. 40°–60°) suspension, with N/2 sulfuric acid. As marked solvent effects have been noted in connection with the determination of optical properties of this compound (see Volkmann,¹⁶ and Naves and Angla¹⁷), particular care should be given to this determination. Moreover, Petit and Tallard¹⁸ found the reagents of Girard and Sandulesco suitable for extracting the isomenthone as they form water soluble complexes which are insoluble in nonhydroxylic organic solvents.

Identification.—The isomeric menthones can be characterized by the preparation of several derivatives, according to Kishner,¹⁹ Pickard and Littlebury,²⁰ Neuberg and Neimann,²¹ Beckmann,²² Read, Cook and Shannon,²³ Read and Cook,²⁴ Rupe and Gassmann,²⁵ Strain,²⁶ Zeitschel and Schmidt,²⁷ Guha and Nath,²⁸ Earl, Johnson and McKean,²⁹ Read,³⁰ Penfold, Ramage and Simonsen,³¹ and Allen.³² These derivatives are presented in tabular summary, indicating melting points:

Derivative	Menthone		
	<i>d</i>	<i>l</i>	<i>dl</i>
Oxime	59° ²⁵	59° ²⁵	81°–82° ²⁴ iso- 114°–115° ²⁴
Semicarbazone	187°–189° ²⁰	189° ²⁰	α- 185°–186° ²⁴ β- 161° ²⁴
2,4-Dibromo- Azine	... 51° ¹⁹	78°–79° ²⁸ 51° ¹⁹
Thiosemicarbazone	155°–157° ²¹ *	155°–157° ²¹ *	...
HCOONH ₄ der. (<i>neo</i> form) (formylamine)	117°–118° ²³	117°–118° ²³	86° ²³
Oxime·HCl	95°–100° ²²	118°–119° ²²	...
3-Nitrobenzohydrazone	105°–107° ²⁶ *
Nitroso oxime	124°–125° ²⁹	124°–125° ²⁹	...
2,4-Dinitrophenyl- hydrazone	141°–142° ³¹ 145° ³²
Benzoyl oxime	72°–73° ²⁴
	Isomenthone		
Semicarbazone	164° ²⁷	164° ²⁷	α- 225° ²⁴ β- 177°–178° ²⁴
Oxime	Liquid ^{27,30}	Liquid ^{27,30}	99°–100° ²⁴ iso- 94°–95° ²⁴
HCOONH ₄ der. (formylamine)	45°–46° ²³	45°–46° ²³	45°–47° ²³
Oxime·HCl	132° ³⁰	132° ³⁰	127°–128° ²⁴
Benzoyl oxime	55.5° ²⁴

* Optical rotation of menthone not indicated.

Regarding the quantitative determination of menthone, see Vol. I, Chapter 4 "The Examination and Analysis of Essential Oils, Synthetics, and Isolates," p. 286.

Properties.—*l*-Menthone is a colorless mobile liquid with an odor reminiscent of peppermint, but harsher. The taste is bitter and less cooling than that of *l*-menthol. Soluble in 3 volumes of 70 per cent alcohol.

The following properties have been reported by Pickard and Littlebury,³³ Wallach,³⁴ Kondakov and Bachtschiev,³⁵ Read and Robertson,³⁶ Hiraidzumi,³⁷ Dulou,³⁸ Rupe and Gassmann,³⁹ von Rechenberg,⁴⁰ Henderson, Henderson and Heilbron,⁴¹ Goethals,⁴² and Huggett:⁴³

	m. °C.	b. °C.	d	α_D	n_D
<i>dl</i> -Menthone		b. 206–207 ³⁷ b ₇₄₈ 205 ³³	d ₄ ²⁵ 0.8936 ³⁷ d ₁₈ 0.895 ³⁸		n _D ²⁵ 1.4492 ³⁷ n _D ¹⁸ 1.4538 ³⁸
<i>d</i> -Menthone		b ₇₅₀ 204 ³³ b ₁₂ 89 ³⁹	d ₁₈ ¹⁸ 0.8950 ³³	[α] _D ²⁰ +25° 42' ³⁹ [α] _D ¹⁸ +24° 51' ³³	
<i>l</i> -Menthone	–7 ²	b. 209– 210 ^{40,41,43} b ₁₀₀ 137 ⁴⁰ b ₂₀ 96 ⁴⁰ b ₁₀ 81 ⁴⁰	d ₄ ²⁵ 0.8895 ³⁷ d ₂₀ 0.8946 ⁴³	[α] _D –29° 28' ³⁷ [α] _D ²⁰ –29° 36' ³⁶ [α] _D ²⁰ –28° 18' ⁴³	n _D ²⁵ 1.4481 ³⁷ n _D ²⁰ 1.4504 ⁴³
<i>dl</i> -Isomenthone		b. 210 ³⁴	d ₂₀ 0.8975 ³⁴		n _D ²⁵ 1.4496 ³⁷
<i>d</i> -Isomenthone	–35 ⁴³	b. 212 ⁴³	d ₄ ²⁵ 0.8952 ³⁷ d ₂₀ 0.9000 ⁴³	[α] _D ²⁰ +95° 0' ⁴³	n _D ²⁵ 1.4511 ³⁷ n _D ²⁰ 1.4530 ⁴³
<i>l</i> -Isomenthone		b. 208.5– 209.5 ³⁵ b ₇ 79–80 ³⁶	d ₁₉ ¹⁹ 0.9004 ³⁵	[α] _D ²⁰ –94° 18' ⁴² [α] _D ¹⁵ –71° 25' ³⁶	n _D ¹⁹ 1.4536 ³⁵ n _D ¹³ 1.4580 ³⁶

Under the influence of acids or alkalis, *l*-menthone is readily inverted to *d*-isomenthone. Oxidation of menthone with chromic acid in acetic acid solution yields β -methyl- δ -isobutyryl-*n*-valeric acid. With potassium permanganate as oxidizing agent, *d*- β -methyl-adipic acid is formed together with smaller quantities of a ketonic acid, methylsuccinic, and other acids. Dilthey, Inckel and Stephan⁴⁴ found that *l*- and *d*-isomenthones do not yield peroxides when subjected to oxidative action of perhydrol.

Use.—Menthone, as such, serves in the compounding of imitation (artificial) essential oils.

¹ *J. Chem. Soc.* **127** (1925), 1868.

² *Ber.* **59** (1926), 2301.

- ³ *J. Chem. Soc.* (1927), 1278.
⁴ *Chem. Rev.* **7** (1930), 1.
⁵ Anniversary Volume dedicated to Masumi Chikashige on his 60th birthday (1930), 85. *Chem. Abstracts* **24** (1930), 5032.
⁶ *J. Chem. Soc.* (1940), 280.
⁷ *J. Am. Chem. Soc.* **65** (1943), 102, 245, 402.
⁸ *Ber. Schimmel & Co.* (1932), 34.
⁹ *Helv. Chim. Acta* **26** (1943), 162.
¹⁰ *Chimie & industrie* **41** (1939), 234.
¹¹ *Natuurw. Tijdschr. Belg.* **23** (1941), 81, 121; **24** (1942), 15. *Chem. Abstracts* **37** (1943), 6410.
¹² *Apoth. Ztg.* **21** (1906), 927.
¹³ *J. Chem. Soc.* **127** (1925), 2782.
¹⁴ *J. Am. Chem. Soc.* **65** (1943), 102, 245, 402.
¹⁵ *J. Chem. Soc.* (1930), 1616.
¹⁶ *Zeit. physik. Chem. Abt. B* **10** (1930), 161.
¹⁷ *Compt. rend.* **213** (1941), 570.
¹⁸ *Rev. chim. ind.* **48** (1939), 226.
¹⁹ *J. Russ. Phys. Chem. Soc.* **39** (1907), 1246.
²⁰ *J. Chem. Soc.* **101** (1912), 124.
²¹ *Ber.* **35** (1902), 2053.
²² *Liebigs Ann.* **250** (1889), 333, 340.
²³ *J. Chem. Soc.* (1926), 2225. See Wallach, *Liebigs Ann.* **276** (1893), 314; **300** (1898), 278.
²⁴ *J. Chem. Soc.* **127** (1925), 2782. Cf. *ibid.* (1927), 1283.
²⁵ *Helv. Chim. Acta* **17** (1934), 283; **12** (1929), 193, 200. Cf. Simonsen, "The Terpenes," Vol. I (1947), 315.
²⁶ *J. Am. Chem. Soc.* **57** (1935), 758.
²⁷ *Ber.* **59** (1926), 2307.
²⁸ *Ber.* **70** (1937), 931.
²⁹ *J. Proc. Roy. Soc. N. S. Wales* **72** (1938), 109.
³⁰ *J. Soc. Chem. Ind.* **46** (1927), 873.
³¹ *J. Chem. Soc.* (1939), 1496.
³² *J. Am. Chem. Soc.* **52** (1930), 2955.
³³ *J. Chem. Soc.* **101** (1912), 124.
³⁴ *Liebigs Ann.* **397** (1913), 217.
³⁵ *J. prakt. Chem.* [2], **63** (1901), 54.
³⁶ *J. Chem. Soc.* (1926), 2216.
³⁷ Anniversary Volume dedicated to Masumi Chikashige on his 60th birthday (1930), 85. *Chem. Abstracts* **24** (1930), 5032.
³⁸ *Bull. inst. pin* (1934), 177.
³⁹ *Helv. Chim. Acta* **12** (1929), 196.
⁴⁰ "Einfache und fraktionierte Destillation in Theorie und Praxis," Miltitz, 2d Ed. (1923), 294.
⁴¹ *Ber.* **47** (1914), 887.
⁴² *Natuurw. Tijdschr. Belg.* **24** (1942), 15. *Chem. Abstracts* **37** (1943), 6410.
⁴³ *J. Soc. Chem. Ind.* **60** (1941), 68T.
⁴⁴ *J. prakt. Chem.* **154** (1940), 219.

SUGGESTED ADDITIONAL LITERATURE

John Read, "Biogenetic Relationships in the Menthone Series," *J. Soc. Chem. Ind.* **48** (1929), 786.

Lawrence H. Baldinger, "Assay for Menthone in Oil of Peppermint," *Proc. Indiana Acad. Sci.* **52** (1942), 111 (Pub. 1943). *Chem. Abstracts* **38** (1944), 1075.

Y. R. Naves, "Sur l'huile essentielle de *Micromeria abyssinica* (Hochst.) Benth., Source de *d*-Isomenthone," *Helv. Chim. Acta* **31** (1948), 932.

Carvomenthone

(Tetrahydrocarvone)

 $C_{10}H_{18}O$

Mol. Weight 154.24

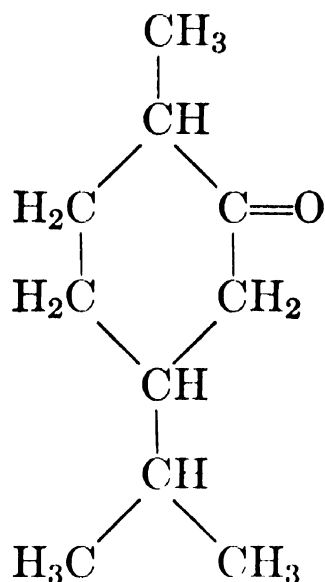
p-Menthane-2-one. 1-Methyl-4-isopropylcyclohexan-2-one

Occurrence.—Simonsen and Rau¹ found that oil of *Blumea malcolmii* contains about 16 per cent *l*-carvomenthone. This ketone occurs also in oil of *Blumea eriantha* fam. *Compositae*.²

Isolation.—By fractional distillation of the oil, preparation and decomposition of the semicarbazone.

Identification.—Carvomenthone may be characterized by its semicarbazone (*d*- and *l*- form m. 194°–195°, *dl*- form m. 174°); also by its oxime (*d*- and *l*- form m. 97°–99°, *dl*- form m. 105°).

Properties.—This ketone is a colorless oil with a menthone-carvone-like odor.

In view of the number of possible stereoisomers of this ketone, particular attention should be given to source, processing, and method of isolation when defining the properties of this product.

Simonsen and Rau³ found the following properties for natural *l*-carvomenthone. It will be observed that these authors reported a rotation of about -9° .

b_{705}	218.5°–219°	$[\alpha]_D^{30}$	$-9^\circ 20'$
d_{30}^{30}	0.9001	n_D^{30}	1.4531

On the other hand, Hückel and Wilip,⁴ Vavon,⁵ and Wallach⁶ preparing this *l*- isomer synthetically from dextrorotatory carvone by catalytic hydrogenation apparently obtained two forms. That of Hückel, which he describes as *trans*- carvomenthone, possessed a rotation of $-7^\circ 30'$; whereas those of Vavon and Wallach, in spite of correspondence in other characteristics, gave $[\alpha]_D$ figures of $-24^\circ 53'$ to $-27^\circ 57'$. Hückel and Doll⁷ had earlier reported

characteristics on certain indirect derivatives of these forms, while Bradfield, Jones and Simonsen⁸ observed an *l*-2,4-dinitrophenylhydrazone melting at 133°.

A similar series of results were obtained by Read and Johnston,⁹ but these authors observed optical rotations higher than any thus far reported:

<i>l</i> -Carvomenthone obtained from <i>d</i> -Carvone with Catalytic H ₂		<i>l</i> -Carvomenthone obtained from <i>d</i> -Carvomenthol with CrO ₃	
b ₁₆	98°–99°	b ₁₆	96°–96.5°
[α] _D ²⁰	–30° 37'	[α] _D ¹⁷	–6° 0'
n _D ²⁰	1.4552	n _D ¹⁷	1.4548

Nagasawa¹⁰ catalytically hydrogenated *l*-carvone derived from Japanese mint oil (*Mentha viridis* L. var. *crispa* Benth.) and obtained *d*-carvomenthone. This compound b₅ 83°–84°, [α]_D²¹ +17° 9', yielded two semicarbazones and an oxime possessing the following properties:

Semicarbazones

	<i>I</i>		<i>II</i>
	(Yield 84.2%)		(Yield 11.6%)
m.	192°–193°	m.	160°–164°
[α] _D ²⁸	+9° 51' (in chloroform)	[α] _D ²⁸	+43° 35' (in chloroform)

Oxime

m.	98°–99°
[α] _D ³⁴	+36° 35' (in alcohol)

Decomposition of these two semicarbazones, I and II, yielded respectively *d*-β-carvomenthone and *d*-α-carvomenthone with the following properties:

<i>d</i> -β-Carvomenthone		<i>d</i> -α-Carvomenthone	
b ₆	87°–88°	b ₆	88°–89°
[α] _D ¹⁵	+11° 48'	[α] _D ¹⁵	+42° 3'

Wallach¹¹ reported for *dl*-carvomenthone prepared from *dl*-carvomenthol:

b.	220°–221°
d ₂₀	0.90
n _D ²⁰	1.4554

Use.—Carvomenthone has not found any noteworthy use in the perfume or flavor industries.

¹ *J. Chem. Soc.* **121** (1922), 881.

² *Ber. Schimmel & Co.* (1937), 7.

- ³ *J. Chem. Soc.* **121** (1922), 881.
⁴ *J. prakt. Chem.* **158** (1941), 21.
⁵ *Compt. rend.* **153** (1911), 70.
⁶ *Liebigs Ann.* **381** (1911), 64.
⁷ *Ibid.* **526** (1936), 103.
⁸ *J. Chem. Soc.* (1935), 315.
⁹ *Ibid.* (1934), 226.
¹⁰ *Repts. Osaka Imp. Ind. Res. Inst.* **19**, No. 4 (1938). *Chem. Abstracts* **34** (1940), 219.
¹¹ *Liebigs Ann.* **277** (1893), 135. *Ber.* **28** (1895), 1962.

Piperitone

C₁₀H₁₆O

Mol. Weight 152.23

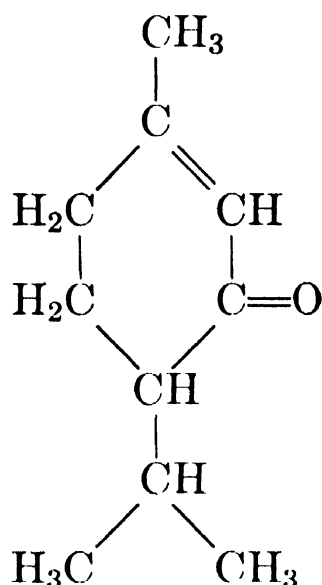
1-*p*-Menthen-3-one. 1-Methyl-4-isopropyl-1-cyclohexen-3-one

Occurrence.—The racemic form of piperitone can be prepared synthetically while both the *d*- and *l*- forms occur in several essential oils.

d-Piperitone has been found in Japanese mint oil (*Mentha arvensis* var. *piperascens*). It forms the main constituent of oil of *Andropogon iwarancusa* Jones (about 80 per cent), and oil of *Cymbopogon sennaarensis* Chiov. (about 45 per cent), the so-called Sudan “Mahareb” grass.

l-Piperitone occurs in several eucalyptus species—e.g., in certain types of *Eucalyptus dives* (about 40 per cent) and *E. radiata*. Oil of *E. dives* forms the principal source of *l*-piperitone. Usually this ketone is associated with *l*-piperitol and *l*- α -phellandrene.

Isolation.—By fractional distillation—e.g., oil of *Eucalyptus dives* type—a ketone of 93% purity can be isolated. A high degree of purity may be attained by the preparation of the crystalline derivative which piperitone forms with sodium bisulfite or sodium sulfite, and by the regeneration of the parent ketone from this compound.

For the isolation of piperitone, Read and Smith¹ recommended the following method:

Mix 700 g. of sodium bisulfite, 1,000 cc. of water and 1,750 cc. of *Eucalyptus dives* oil in a vessel provided with a steam jacket and attached to a shaking machine. Shake

the mixture for 10 hr. while heating with steam. Pour the product of reaction into a large vessel and let it cool overnight. Remove the oil which has not reacted, collect the crystalline mass on a suction filter, filter, wash once with methyl alcohol and twice with ether. Dissolve the mass in hot water, filter and regenerate the ketone from the bisulfite compound by adding to the hot filtrate a concentrated solution of sodium hydroxide. Separate the ketone from the aqueous layer, wash with warm water, and dry over sodium sulfate and filter.

Identification.—(1) The most modern technique for the preparation of *l*-piperitone is reported by Blagden and Huggett;² these authors offered a patented process employing low temperature and recrystallization for the isolation of this terpenic derivative.

(2) According to Smith and Penfold,³ piperitone can be detected most conveniently by the reduction of the ketone, in alcoholic-etheral solution, with sodium amalgam which reaction produces a pinacone (1,1'-bismenthone) $C_{20}H_{34}O_2$, m. 148° – 149° . The melting point of this ketone is somewhat indefinite, but by fractional crystallization the compound may be resolved into isomers melting respectively at 135° – 136° and at 166° – 167° .

For the preparation of the pinacone, 1 cc. of oil, which must contain at least 10% piperitone, is mixed with 1 cc. of alcohol, 4 cc. of ether, and 1.3 g. of sodium amalgam. The mixture immediately assumes a brown color, and after 10 min. an amber-white precipitate of the pinacone m. 142° – 149° will be observed. Upon recrystallization of the substance from chloroform, the two isomers melt at 135° – 136° , and at 166° – 167° .

(3) On treatment with semicarbazide, *dl*-piperitone yields a mixture of two semicarbazones. According to Read and Smith,⁴ the very sparingly soluble α -semicarbazone melts at 226° – 227° , the β -form at 174° – 176° .

From *d*-piperitone, Simonsen⁵ prepared the optically active α -semicarbazone m. 193° – 194° . The optically active form of *l*-piperitone semicarbazone does not appear to have been described. It should be kept in mind that the optically active forms of piperitone are apt to be racemized during the conversion into the semicarbazones.

(4) Read, Smith, and Bentivoglio⁶ prepared from *dl*-piperitone two oximes, the α -oxime m. 118° – 119° , and the β -oxime m. 88° – 89° , both of which yield the same hydrochloride m. 157° (decomposition). An excess of hydroxylamine during the reaction with *dl*-piperitone causes the formation of α - and β -hydroxylamino-oxime (see below).

Thus, the action of hydroxylamine on *dl*-piperitone results in the formation of a mixture of two isomeric oximes and two isomeric hydroxylamino-oximes. The oxime mixture is obtained with the calculated quantity of hydroxylamine. But even under these conditions, hydroxylamino-oxime is partly formed. Therefore, the oxime mixture must be freed from adhering hydroxylamino-oxime by steam distillation.

The oxime mixture melts at 107° – 109° which, by recrystallization from methyl or ethyl alcohol, is separated into the α -oxime m. 118° – 119° , and the β -oxime m. 88° – 89° (see above). As mentioned, an excess of hydroxylamine causes the formation of hydroxylamino-oxime m. 164° – 165° . Due to their low volatility, these compounds can easily be separated from the oximes and from the piperitone.⁷

Read and Smith⁸ showed that the hydroxylamino-oxime mixture consists of *dl*-piperitone- α -hydroxylamino-oxime m. 176° , and *dl*-piperitone- β -hydroxylamino-oxime m. 185° – 186° .

The oximes of *d*- and *l*-piperitone are liquids; in the presence of an excess of alkali only the racemic oximes are formed.

Regarding the quantitative determination of piperitone, see Vol. I, Chapter 4, "The Examination and Analysis of Essential Oils, Synthetics, and Isolates," p. 283.

Properties.—Piperitone is an oil possessing a mint- and camphor-like odor. Colorless, when freshly distilled, piperitone turns yellow on aging, but this tendency is less pronounced in products purified through their semicarbazones. The products formed by autoxidation of piperitone were described by Treibs.⁹

The properties of piperitone have been variously reported. The information gathered by Read and Smith¹⁰ was derived from a very carefully purified sample. The constants studied and confirmed by Wallach and Meister,¹¹ Roberts,¹² Schimmel & Co.¹³ and Huggett¹⁴ are tabulated:

d-Piperitone

b_{20}	$116^{\circ}-118.5^{\circ}$ ¹⁰	$[\alpha]_D^{20}$	$+49^{\circ} 8'$ ¹⁰
d_4^{20}	0.9344 ¹⁰ (vac.)	n_D^{20}	1.4848 ¹⁰

l-Piperitone

m.	-29° ¹⁴	$[\alpha]_D^{20}$	$-51^{\circ} 32'$ ¹⁰
b.	$232.5^{\circ}-234.7^{\circ}$ ¹⁴	$[\alpha]_D^{20}$	$-67^{\circ} 48'$ ¹⁴ (homogeneous)
b_{15}	$109.5^{\circ}-110.5^{\circ}$ ¹⁰	n_D^{20}	1.4848 ¹⁰
d_4^{20}	0.9324 ¹⁰ (vac.)		1.4845 ¹⁴
d_{20}	0.9330 ¹⁴		

dl-Piperitone

b.	$235^{\circ}-237^{\circ}$ ^{11,12}	n_D^{20}	1.4845 ¹⁰
b_{18}	113° ¹⁰		1.4844 ¹³
d_4^{20}	0.9331 ¹⁰ (vac.)	n_D^{19}	1.4875 ¹¹
d_{19}	0.9375 ¹¹		
d_{15}	0.9387 ¹²		

According to early workers, the optically active forms of piperitone easily racemize, part racemization taking place when distilled at atmospheric pressure. Complete racemization occurs when piperitone is purified through its bisulfite compound, especially during the regeneration of the ketone from its bisulfite compound by the action of alkali. This seems to be caused by enolization of the ketone which involves loss of the original molecular asymmetry. Acids are less effective in causing racemization. This, however, is disputed in the recent investigations of Huggett,¹⁴ and to some extent by Nerdel and Doll.¹⁵ These authors found the optical rotation of pure *l*-piperitone prepared by recrystallization as $[\alpha]_D^{20} -67^{\circ} 48'$. Their work indicated that the commercial processes for the isolation of this ketone, contrary to the findings of original workers, cause little racemization. Furthermore, the rotation which was discovered in the natural isolates indicated that this terpenic derivative occurs in nature in a partially racemized state. However, more re-

cent findings of Huggett and co-workers¹⁶ indicate that the specific rotation varies considerably with the solvent selected, these investigators reporting values $[\alpha]_D^{20}$ from -16° in acetic acid to $-77^\circ 30'$ in benzene.

In the opinion of Nerdel and Doll (see above), the hitherto known piperitone is a mixture of optically active and racemic piperitone. The fully active piperitone should have a rotation of $\pm 67^\circ$.

Reduction of *d*-, or *l*-, or *dl*-piperitone with sodium in alcoholic solution yields *dl*-isomenthols and *dl*-menthols, with the simultaneous formation of some *dl*- α -phellandrene. Regarding other methods of hydrogenation, the reader is referred to Simonsen,¹⁷ and to a paper by Nerdel and Doll.¹⁸

Oxidation with ferric chloride gives thymol with a yield of about 25 per cent.

By the oxidation with potassium permanganate in neutral solution, diosphenol is formed, according to Roberts.¹⁹

Use.—Piperitone is used for the scenting of many technical preparations, but its main employment is as a starting material for the preparation of synthetic menthol and thymol.

¹ *J. Soc. Chem. Ind.* **42** (1923), 339T.

² U. S. Patent No. 2,264,928, Dec. 2, 1941.

³ *J. Proc. Roy. Soc. N. S. Wales* **54** (1920), 40. *Tech. J. Australia* **1** (1922), 11. Technological Museum, Sydney, Bulletin No. 1. Cf. Baker and Smith, "The Eucalypts" (1923), 393. Carter and Read, *J. Soc. Chem. Ind.* **45** (1926), 45T.

⁴ *J. Chem. Soc.* **121** (1922), 1866.

⁵ "The Terpenes," Vol. I (1947), 367.

⁶ *J. Chem. Soc.* **121** (1922), 587.

⁷ See also *Ber. Schimmel & Co.*, Oct. (1910), 80; (1923), 195.

⁸ *J. Chem. Soc.* **123** (1923), 2272.

⁹ *Ber.* **63** (1930), 2423; **64** (1931), 2178; **66** (1933), 610.

¹⁰ *J. Chem. Soc.* **123** (1923), 2268.

¹¹ *Liebigs Ann.* **362** (1908), 271.

¹² *J. Chem. Soc.* **107** (1915), 1466.

¹³ *Ber. Schimmel & Co.*, Oct. (1910), 79.

¹⁴ *J. Soc. Chem. Ind.* **60** (1941), 67T.

¹⁵ *Ber. Schimmel & Co.* (1939), 116.

¹⁶ *J. Soc. Chem. Ind.* **60** (1941), 67T.

¹⁷ "The Terpenes," Vol. I (1947), 364.

¹⁸ *Ber. Schimmel & Co.* (1939), 116.

¹⁹ *J. Chem. Soc.* **107** (1915), 1466.

Pulegone

 $C_{10}H_{16}O$

Mol. Weight 152.23

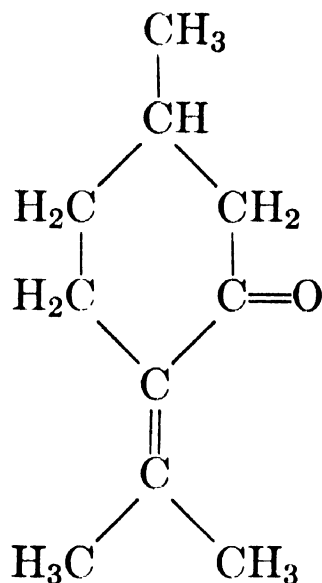
4(8)-*p*-Menthen-3-one. 1-Methyl-4-isopropylidenecyclohexan-3-one

Occurrence.—*d*-Pulegone occurs as a main constituent (80–90 per cent) in pennyroyal oil (*Mentha pulegium* and *Hedeoma pulegioides*); it has also been observed in Japanese mint oil (*Mentha arvensis* var. *piperascens*), in oil of *Pycnanthemum lanceolatum*, *Calamintha nepeta*, etc.

Isolation.—Pulegone can be isolated from essential oils, and purified by conversion into the addition compound with sodium bisulfite or, preferably, sodium sulfite from which the ketone can be regenerated by the action of alkali. For this purpose, Baeyer and Henrich¹ suggested diluting oil of pennyroyal with 0.25 volumes of alcohol, and shaking the mixture for a prolonged time with sodium bisulfite solution. The crystalline complex is then decomposed with soda. Although the original directions as published by Baeyer and Henrich² for the preparation of this crystalline complex are still operative, nevertheless improvements have been recommended by several authors that lead not only to a speedier determination but also to the separation of this ketone from contaminants sometimes found associated with it in essential oils—as, for instance, the isomeric menthones and piperitenones in oil of pennyroyal. Where these factors are likely to be of importance the worker should be guided by the research of Burgess,³ Bennett,⁴ Penfold,⁵ Dulou,⁶ Foote and Matthews,⁷ and Naves⁸ wherein the influences of time, temperature and pH are studied with respect to derivative formation by this rather inactive carbonyl compound.

For the isolation as well as for the quantitative determination of pulegone, the sodium sulfite method is generally preferred to the sodium bisulfite method. Since pulegone does not react readily with sodium sulfite the process should be carried out with a hot neutral sodium sulfite solution and with shaking for 4 hr. on a boiling water bath. However, the values thus obtained will not only represent pulegone but will include other carbonyl compounds present in the oil.

Pure *d*-pulegone may also be obtained by preparing the semicarbazone and by regenerating the parent ketone through the action of acids.

The regenerative procedure of Kon⁹ is also to be recommended, wherein the semicarbazone suspended in light petroleum (b. 40°–60°) is mechanically agitated with the calculated amount of N/2 sulfuric acid until hydrolysis is complete and no more solid remains.

Where certain ketones, as those observed in oil of pennyroyal, are present, Naves¹⁰ has found the fractionation of the phenyl semicarbazones a useful method of purification.

Identification.—Several derivatives may serve for the characterization of pulegone:

(1) According to Baeyer et al.,¹¹ the most satisfactory compound is *bis*-nitrosopulegone m. 81.5°, which may be prepared by the action of hydrochloric acid on a mixture of pulegone and amyl nitrite. For this purpose a solution of 2 cc. of pulegone or pulegone-containing oil in 2 cc. of petroleum ether and 1 cc. of amyl nitrite is well cooled in a freezing mixture and treated with a very small quantity of hydrochloric acid. The *bis*-nitrosopulegone will separate after a short time in the form of fine needles which can be obtained in pure form by spreading them on porous clay plates and by washing with petroleum ether. These crystals decompose on recrystallization. Isopulegone does not form a *bis*-nitroso compound.

On treatment with alkali, *bis*-nitrosopulegone is converted into isonitrosopulegone m. 122°–127°.

A new series of nitroso compounds have been prepared from the nitrite-treated reaction product of pulegone and amines, by Adamson and Kenner.¹² These derivatives are of the general formula

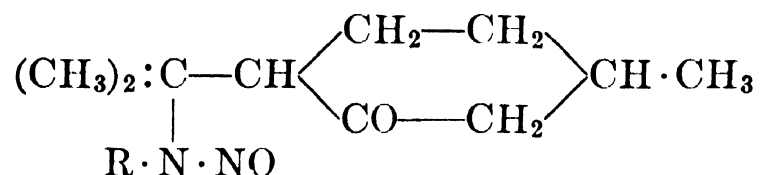

and may well serve for purposes of identification. R in the formula corresponds to the alkyl groups indicated in the following table of these nitroso derivatives:

<i>R</i> = Alkyl Group	<i>m.</i> °C.
CH ₃ -	116.5
C ₂ H ₅ -	108.5
<i>n</i> -C ₃ H ₇ -	125.5
<i>n</i> -C ₄ H ₉ -	89
<i>n</i> -C ₅ H ₁₁ -	88.5
<i>n</i> -C ₇ H ₁₅ -	70
Allyl-	108

(2) According to Doevre and Perret,¹³ *d*-pulegone gives a semicarbazone m. 174°, and Naves¹⁴ reports the 4-phenyl semicarbazone as m. 142°–143°.

An unusual derivative from pulegone and semicarbazide has been reported by Busse and Gurevich;¹⁵ it is obtained under the same conditions as used by Beckmann and Pleissner for oximation. This carbaminy pyrazoline melts at 156°–157°.

(3) With hydroxylamine, pulegone gives several derivatives:

Hydroxylamine hydrochloride in the presence of sodium bicarbonate yields pulegone hydroxylamine C₁₀H₁₆O·NH₂OH, m. 157°, according to Beckmann and Pleissner.¹⁶ In this case, hydroxylamine is added to the ethylenic linkage. When treating pulegone with hydroxylamine in the presence of alkali, Wallach¹⁷ obtained a normal oxime C₁₀H₁₆:NOH, m. 120°–121°, which however is not *d*-pulegoneoxime, but *d*-isopulegoneoxime. At the same time hydrolysis occurs by the action of alkali and the yield of oxime will be poor. By the action of excess hydroxylamine on pulegone, Semmler¹⁸ obtained pulegone hydroxylamino-oxime, C₁₀H₁₆·NOH·NH₂OH, m. 118°, while Cusmano¹⁹ reported the existence of a second hydroxylamino-oxime m. 143°.

Sabetay²⁰ suggested a simplified oximation method for pulegone in which the reaction mixture is heated in the presence of CaCO₃.

(4) Baeyer and Henrich ²¹ prepared pulegone hydrochloride (8-chloro-*p*-menthan-3-one), by the action of hydrogen chloride on pulegone in acetic acid solution. This hydrochloride crystallizes in rhombic crystals m. 24°–25° and can easily be reconverted into pulegone with alkali.

(5) The inactivity of the carbonyl group in this compound is again made evident in difficulties attendant upon the formation of the 2,4-dinitrophenylhydrazone derivative m. 142°, according to Brady ²² (also consult in this connection the work of Allen, ²³ and Fernandez, Socias and Torres ²⁴).

For the quantitative determination of pulegone, see Vol. I, Chapter 4, "The Examination and Analysis of Essential Oils, Synthetics, and Isolates," p. 283.

Properties.—*d*-Pulegone is an oil with an odor reminiscent of menthone and menthol. Colorless, when freshly prepared, pulegone assumes a yellowish tint on aging.

Natural pulegone is usually accompanied by other ketones; in order to obtain pulegone in pure form it must be freed from these impurities by conversion to a suitable derivative from which pulegone is regenerated. The following characteristic properties, reported by Beckmann and Pleissner, ²⁵ Barbier, ²⁶ Baeyer and Henrich, ²⁷ Wallach, ²⁸ Grignard and Savard, ²⁹ Gildemeister and Hoffmann, ³⁰ Kon, ³¹ Dulou, ³² Doeuvre and Perret, ³³ Naves et al., ^{34, 35} and Manzoni-Ansidci, ³⁶ have all been observed in samples obtained by treatment of pulegone with sulfites or semicarbazide:

PROPERTIES

b. °C.		d		[α]	n _D	
b.	221–223 ^{26, 28}			+22° 22' ³⁵ +22° 53' ²⁵	n _D ²⁰	1.4864 ³⁴
b ₆₀	130–131 ²⁵	d ₄ ^{19–20}	0.9370–0.9374 ^{33, 34, 35}	+22° 58' ³³	n _D ¹⁹	1.4880 ³³
b ₁₉	109 ³¹	d ₄ ¹⁷	0.9390 ³³		n _D ^{16.9}	1.4881 ³¹
b ₁₈	105 ³²	d ₁₅ ¹⁵	0.939–0.941 ³⁰			
b ₁₇	103 ³³	d ₁₅ ¹⁵	0.9405 ³⁰ (pure)			
b ₁₅	100–101 ²⁷					
b ₁₀	94–95 ³⁵					
b _{8–9}	93–94 ³⁰					
b _{5–6}	84–85 ^{29, 30}					

M.R. D	{ Obs.	46.78 ³³	46.65 ³⁴	
	{ Calc.	45.72 ³³		
Parachor	{ Obs.	387.6 ³³	390.2 ³⁶	384.4 ³⁴
	{ Calc.	394.1 ³³		

Extensive studies of the optical properties (n and α_D over a wide range of wave lengths) of this ketone have been made by Lowry, Simpson and Allsopp, ³⁷ and again by Simpson ³⁸ wherein the latter author concludes, in connection with the enhanced molecular refractivity of this compound, that

such an effect "results from the invalidity of the additive relationship in the presence of strongly chromophoric radicals."

This optical exaltation is observed to be even more pronounced in samples purified by chemical treatments (cf. Naves and Papazian,³⁹ and Doeuvre and Perret⁴⁰).

Pulegone is fairly stable in most of its reactions and can be distilled without harm, but it shows some tendency to decompose, yielding thereby acetone and 1-methyl-cyclohexan-3-one.

On oxidation with potassium permanganate, pulegone gives acetone and β -methyladipic acid.

Less vigorous action of oxygen, as autoxidation or photodecomposition in air, evidently develops lactones. Serniagiotto⁴¹ offers such evidence in photolyzed pulegone and Naves⁴² found similar products in commercial oil of pennyroyal.

The reduction of pulegone has become a reaction of commercial importance inasmuch as menthol may be derived, either by chemical or catalytic hydrogenation.

Reducing pulegone with sodium and alcohol, Beckmann and Pleissner⁴³ early obtained *l*-menthol $C_{10}H_{20}O$, m. 38° and $[\alpha]_D -86^\circ 25'$, together with some menthone. This technique is suitable for the laboratory; however, catalytic hydrogenation has replaced this procedure commercially and Rutovskii, Kolobelotzkaya and Yaroslavtzeva⁴⁴ have so far improved this reduction recently as to report near theoretical yields by use of a nickel catalyst. An intermediary product of reduction, in the above reaction, is pulegol $C_{10}H_{18}O$. This reaction likewise is accompanied by many difficulties and has been studied from many angles by Doeuvre and Perret.⁴⁵

Use.—Pulegone is used for the scenting of soaps, but principally it serves as starting material for the making of synthetic menthol.

¹ *Ber.* **28** (1895), 652.

² *Ibid.*

³ *Analyst* **29** (1904), 78.

⁴ *Perfumery Essential Oil Record* **9** (1918), 208.

⁵ *Ibid.* **13** (1922), 21.

⁶ *Bull. inst. pin* (1934), 173.

⁷ *J. Am. Pharm. Assocn.* **31** (1942), 65.

⁸ *Helv. Chim. Acta* **26** (1943), 162. *Perfumery Essential Oil Record* **35** (1944), 221.

⁹ *J. Chem. Soc.* (1930), 1616.

¹⁰ *Helv. Chim. Acta* **26** (1943), 162.

¹¹ *Ber.* **29** (1896), 1078.

¹² *J. Chem. Soc.* (1937), 1551.

¹³ *Bull. soc. chim.* [5], **2** (1935), 301.

¹⁴ *Helv. Chim. Acta* **26** (1943), 172.

¹⁵ *Ber.* **63B** (1930), 2209.

¹⁶ *Liebigs Ann.* **262** (1891), 6.

¹⁷ *Ibid.* **277** (1893), 160; **289** (1896), 347; **365** (1909), 241.

¹⁸ *Ber.* **38** (1905), 146.

¹⁹ *Gazz. chim. ital.* **39**, II (1909), 462.

- ²⁰ *Bull. soc. chim.* [5], **5** (1938), 1419.
²¹ *Ber.* **28** (1895), 653.
²² *J. Chem. Soc.* (1931), 758.
²³ *J. Am. Chem. Soc.* **52** (1930), 2955. [Cf. Allen and Richmond, *J. Org. Chem.* **2** (1937), 222.]
²⁴ *Anales soc. españ. fís. quim.* **30** (1932), 37. *Chem. Abstracts* **26** (1932), 2395.
²⁵ *Liebigs Ann.* **262** (1891), 3, 4, 20.
²⁶ *Compt. rend.* **114** (1892), 126.
²⁷ *Ber.* **28** (1895), 653.
²⁸ *Ber.* **28** (1895), 1965.
²⁹ *Bull. soc. chim. Belg.* **36** (1927), 101. *Compt. rend.* **181** (1925), 589; **182** (1926), 422.
³⁰ "Die Ätherischen Öle," 3d Ed., Vol. I, 561.
³¹ *J. Chem. Soc.* (1930), 1616.
³² *Bull. inst. pin* (1934), 173.
³³ *Bull. soc. chim.* [5], **2** (1935), 298.
³⁴ *Helv. Chim. Acta* **25** (1942), 1046.
³⁵ *Perfumery Essential Oil Record* **35** (1944), 221.
³⁶ *Giorn. biol. ind. agrar. aliment.* **7** (1937), 234, *Bologna, Univ. Inst. f. allg. Chem. Chem. Zentr.* I (1938), 3188.
³⁷ *Proc. Roy. Soc. London* **A163** (1937), 483.
³⁸ *J. Chem. Soc.* (1939), 886.
³⁹ *Helv. Chim. Acta* **25** (1942), 1046.
⁴⁰ *Bull. soc. chim.* [5], **2** (1935), 298.
⁴¹ *Rend. accad. Lincei* **24**, [I] (1915), 1065. *Gazz. chim. ital.* **47**, I (1917), 150.
⁴² *Perfumery Essential Oil Record* **36** (1945), 121.
⁴³ *Liebigs Ann.* **262** (1891), 30.
⁴⁴ *J. App. Chem. U.S.S.R.* **9** (1936), 684. *Chem. Abstracts* **30** (1936), 7561.
⁴⁵ *Bull. soc. chim.* [5], **2** (1935), 298.

SUGGESTED ADDITIONAL LITERATURE

W. Treibs, "Sulfonic Acids of Terpenes and Sesquiterpenes and Cyclopulegenol Sulfonic Ester and Its Conversion into Menthofurane," *Ber.* **70B** (1937), 85.

Isopulegone

C₁₀H₁₆O

Mol. Weight 152.23

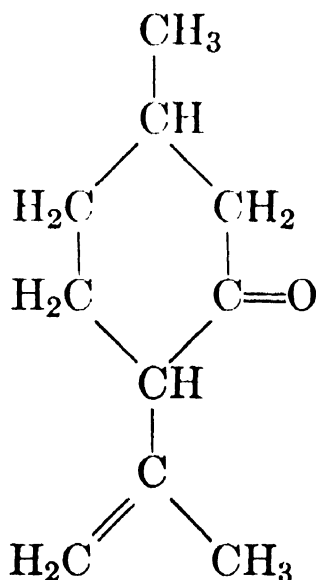
8(9)-*p*-Menthen-3-one. 1-Methyl-4-isopropenylcyclohexan-3-one

Occurrence.—Grignard and Savard¹ reported that the "pulegone" fraction of pennyroyal oil contains about 15 per cent isopulegone. However, Hugh,

Kon and Linstead² questioned these findings. In view of the marked instability of isopulegone, the latter authors hold it doubtful whether this ketone actually accompanies pulegone in normal oil of pennyroyal.

Isolation.—According to Grignard and Savard,³ isopulegone can be separated from the mixture of isomers occurring in pennyroyal oil by treatment with sodium hydrogen sulfite solution. Pulegone forms thereby a crystalline compound, whereas isopulegone does not react with sodium hydrogen sulfite.

According to Kon,⁴ isopulegone may be purified by the preparation of the crystalline semicarbazone (see below) from which the ketone is regenerated by hydrolysis with oxalic acid or with very dilute sulfuric acid.

Identification.—(1) According to Gildemeister and Hoffmann,⁵ the optically active isopulegone can be characterized by the semicarbazone which crystallizes in needles m. 172°–174°, easily soluble in ether. The *dl*-semicarbazone is much more sparingly soluble in ether and melts, according to Wallach,⁶ at 182°–183°. These data have been confirmed in the work of Harries and Roeder.⁷ Doeuve⁸ reported that isopulegone yields two semicarbazones with m. 172°–173° and m. 156°, corresponding to the *cis*- and *trans*- isomers.

(2) Wallach⁹ found that the optically active isopulegone yields an oxime m. 120°–121°. This isopulegoneoxime can be prepared either from isopulegone or from pulegone. The *dl*-isopulegone forms a *dl*-oxime which has been variously reported as regards its melting point. Wallach¹⁰ found 138°–139°, Tiemann and Schmidt¹¹ 134°, Harries and Roeder¹² 143°.

(3) According to Harries and Roeder,¹³ the presence of even 1% pulegone can be established in a mixture of pulegone and isopulegone, if 2 cc. of the sample are mixed with 2 cc. of petroleum ether and 1 cc. of isoamyl nitrite, and 1 drop of fuming hydrochloric acid is added under strong cooling. The nitrosopulegone will separate as a white deposit while the color of the solution turns blue.

Properties.—Isopulegone is a colorless oil possessing an odor very similar to that of pulegone. Pure isopulegone is strongly dextrorotatory. Neither the *l*- form, nor the *dl*- form has been prepared, although derivatives of the latter are known (see above).

The properties of this terpenic ketone have been reported by Grignard and Savard,¹⁴ Hugh, Kon and Linstead,¹⁵ and by Harries and Roeder,¹⁶ and are summarized in the following table:

b ₁₇	101°–102° ¹⁵	[α] _D	+34° 2' ¹⁴
b ₁₃	98°–100° ¹⁶	[α] _D	+24° 42' ¹⁵ (c = 5.55 in methyl alcohol)
b ₅	78° ¹⁴		
d ₄ ^{20.4}	0.92177 ¹⁵	n _D ^{20.4}	1.46787 ¹⁵
d ₄ ²⁰	0.92085 ¹⁵	n _D ²⁰	1.4667 ¹⁵
d _{19.5}	0.9192 ¹⁶	n _D ¹⁴	1.46332 ¹⁴
d ₄ ¹⁴	0.9097 ¹⁴		

The properties observed by Grignard and Savard were determined on pure natural *d*-isopulegone. This applies also to the figures given by Hugh, Kon and Linstead, except those for density and refractive index taken at

20.4° which were obtained on a sample of very pure ketone derived from isopulegol.

Use.—Isopulegone, as such, is used in our industry only to a small extent—for example, in the compounding of imitation essential oils such as geranium, etc.

¹ *Compt. rend.* **181** (1925), 589; **182** (1926), 422.

² *J. Chem. Soc.* (1927), 2585. Kon, *ibid.* (1930), 1617.

³ *Compt. rend.* **181** (1925), 589; **182** (1926), 422.

⁴ *J. Chem. Soc.* (1930), 1616.

⁵ "Die Ätherischen Öle," 3d Ed., Vol. I, 565.

⁶ *Liebigs Ann.* **365** (1909), 253. See also Harries and Roeder, *Ber.* **32** (1899), 3362.

⁷ *Ber.* **32** (1899), 3371.

⁸ *Bull. soc. chim.* [4], **53** (1933), 589.

⁹ *Liebigs Ann.* **365** (1909), 253. See also Harries and Roeder, *Ber.* **32** (1899), 3362.

¹⁰ *Liebigs Ann.* **365** (1909), 252.

¹¹ *Ber.* **29** (1896), 915; **30** (1897), 26.

¹² *Ber.* **32** (1899), 3371.

¹³ *Ibid.* 3369.

¹⁴ *Compt. rend.* **181** (1925), 589; **182** (1926), 422.

¹⁵ *J. Chem. Soc.* (1927), 2585. Kon, *ibid.* (1930), 1617.

¹⁶ *Ber.* **32** (1899), 3371.

Carvotanacetone

C₁₀H₁₆O

Mol. Weight 152.23

6-*p*-Menthen-2-one. 1-Methyl-4-isopropyl-6-cyclohexen-2-one

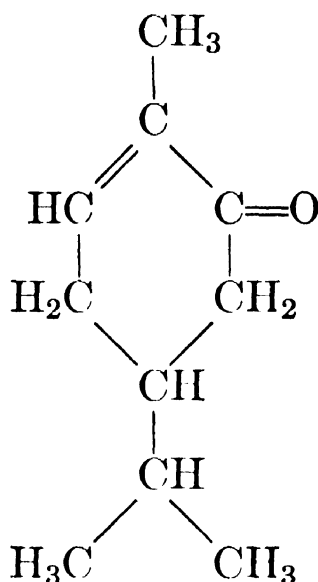

Occurrence.—Simonsen and Rau¹ found *d*-carvotanacetone as a main constituent (about 82 per cent) in oil of *Blumea malcolmii*, fam. *Compositae*.

More recently Schimmel & Co.² examined a sample of oil distilled in East India from *Blumea eriantha* D.C. fam. *Compositae* and found that it contained 95 per cent ketones, mainly *d*-carvotanacetone.

Wallach³ isolated a small percentage of *dl*-carvotanacetone from the high boiling fraction of thuja oil (*Thuja occidentalis*), but pointed out that it remains doubtful whether carvotanacetone exists in this oil as such or whether it is formed from thujone during the process of purification.

Isolation.—After initial washing with both sodium carbonate and sodium hydroxide to remove acids and phenols, the essential oil is treated with neutral sodium sulfite.

Contrary to carvomenthone (tetrahydrocarvone), with which it is sometimes associated in nature, carvotanacetone dissolves readily in a neutral solution of sodium sulfite and can be recovered from this solution by treatment with alkali. This reaction offers a method of isolating carvotanacetone and separating it from carvomenthone. After regeneration of the ketone from the sulfite complex with alkali, complete purification is carried out by distillation.

Identification.—(1) According to Baeyer,⁴ carvotanacetone may be characterized by its semicarbazone, the *dl*- form melting at 177°–179°, the active forms at 173°–174° (cf. also Simonsen and Rau,⁵ Read and Swann,⁶ and Nagasawa⁷).

(2) With hydroxylamine, carvotanacetone forms a highly crystalline oxime, the *dl*- form melting at 94°–95°⁶, the *d*- and *l*- forms at 76°–77°.⁶ When treated with an excess of hydroxylamine, the ketone forms a hydroxylamino-oxime which crystallizes with half a molecule of crystallization water. The active hydroxylamino-oxime melts at 95°–96°, the *dl*- form at 162°.

(3) The phenylhydrazone of the active isomers of carvotanacetone m. 92°–93° was described by Simonsen and Rau,⁸ and the hydrogen sulfide derivative m. 225°–226°.

(4) Read and Swann⁹ found that the 2,4-dinitrophenylhydrazone melts at 191°–192°.

Properties.—Carvotanacetone is an oil possessing an odor very similar to that of carvone. The following properties have been reported:

dl-Carvotanacetone (Brühl¹⁰)

b_{764}	228.0°–228.5°	α_D	$\pm 0^\circ$
d_4^{20}	0.9351	n_D^{20}	1.48056

d-Carvotanacetone (Simonsen and Rau,¹¹ and Read and Swann¹²)

b_{707}	227.5° ¹¹	$[\alpha]_D$	+58° 18' ¹²
$b_{21.5}$	105°–106° ¹²	$[\alpha]_D^{30}$	+59° 33' ¹¹
d_{30}^{30}	0.9305 ¹¹	n_D^{30}	1.4767 ¹¹
		n_D^{20}	1.4796 ¹²

l-Carvotanacetone (Wallach¹³ and Nagasawa¹⁴)

b.	227°–229° ¹³	$[\alpha]_D^{21}$	–60° 34' ¹⁴
b_5	88°–88.5° ¹⁴	n_D^{19}	1.4822 ¹³
d_{15}	0.9345 ¹³		

When oxidizing *d*-carvotanacetone with potassium permanganate in alkaline solution, Simonsen and Rau¹⁵ obtained as sole products of oxidation acetic acid and β -isopropylglutaric acid m. 103°–104°.

Use.—Carvotanacetone has not found any noteworthy use in the perfume or flavor industries.

¹ *J. Chem. Soc.* **121** (1922), 876.

² *Ber. Schimmel & Co.* (1937), 7.

- ³ *Liebigs Ann.* **275** (1893), 182.
⁴ *Ber.* **27** (1894), 1923.
⁵ *J. Chem. Soc.* **121** (1922), 876.
⁶ *Ibid.* (1937), 239.
⁷ *Repts. Osaka Imp. Ind. Res. Inst.* **19**, No. 4 (1938). *Chem. Abstracts* **34** (1940), 219.
⁸ *J. Chem. Soc.* **121** (1922), 876.
⁹ *Ibid.* (1937), 239.
¹⁰ *Ber.* **32** (1899), 1225.
¹¹ *J. Chem. Soc.* **121** (1922), 876.
¹² *Ibid.* (1937), 239.
¹³ *Liebigs Ann.* **336** (1904), 37.
¹⁴ *Repts. Osaka Imp. Ind. Res. Inst.* **19**, No. 4 (1938). *Chem. Abstracts* **34** (1940), 219.
¹⁵ *J. Chem. Soc.* **121** (1922), 876.

Dihydrocarvone

$C_{10}H_{16}O$

Mol. Weight 152.23

8(9)-*p*-Menthen-2-one. 1-Methyl-4-isopropenylcyclohexan-2-one

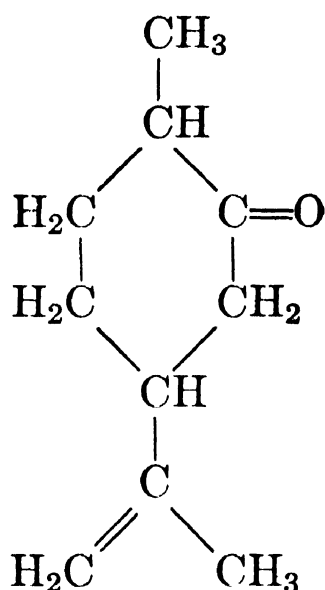

Occurrence.—Schimmel & Co.¹ found small quantities of dihydrocarvone in caraway seed oil.

Isolation.—This menthenone can be isolated from the fraction b. 218°–224° of caraway seed oil; the ketone may be purified through the crystalline compound which it readily forms with sodium bisulfite.

Identification.—Dihydrocarvone is characterized by the preparation of several derivatives:

- (1) The *d*- and *l*-oximes melt at 88°–89°, the *dl*-oxime at 115°–116°.
- (2) According to Baeyer,² the *d*- and *l*-semicarbazones melt at 189°–191°, the *dl*-semicarbazone at 187°–188°.
- (3) According to Wallach,³ a crystalline dibromide is obtained on addition of bromine, drop by drop, to a solution of dihydrocarvone in glacial acetic acid containing hydrogen bromide. The *d*- and *l*-dibromides melt at 69°–70°, the *dl*-dibromide at 96°–97°.

Properties.—Dihydrocarvone is a colorless oil possessing an odor which resembles carvone and menthone.

Schimmel & Co.⁴ reported the following properties for the natural ketone:

$b_{735.5}$	221°	α_D	-16° 18'
d_{15}^{15}	0.9297	n_D^{20}	1.47107

Wallach et al.⁵ found for *l*-dihydrocarvone as prepared from *d*-carvone:

b.	221°-222°	α_D	-17° 45'
d_{19}	0.928	n_D^{19}	1.47174

The only significant difference revealed in the recent literature between properties as earlier reported by Wallach⁶ and those of other workers is the fact that slightly higher rotatory powers have been observed. (Compare Kondakov and Lutschinin,⁷ Kishner,⁸ and Nagasawa⁹ who report rotations between -18° 17' and -19°.) Kondakov and Lutschinin,¹⁰ and Wallach¹¹ also studied the *d*- isomer but found a complete correspondence in properties with those of the *l*- form as recorded by Wallach.

On oxidation with potassium permanganate, dihydrocarvone yields *p*-menthan-2-one-8,9-diol, m. 115°-120°, which forms a semicarbazone m. 187°, and an oxime m. 202°.

Use.—Dihydrocarvone has not found any noteworthy employment in the flavor or perfume industries.

¹ *Ber. Schimmel & Co.*, April (1905), 50.

² *Ber.* **27** (1894), 1923.

³ *Liebigs Ann.* **279** (1894), 389; **286** (1895), 127.

⁴ *Ber. Schimmel & Co.*, April (1905), 50.

⁵ *Liebigs Ann.* **275** (1893), 116; **279** (1894), 381. Cf. Simonsen, "The Terpenes," Vol. I (1947), 352.

⁶ *Ibid.*

⁷ *J. prakt. Chem.* II, **60** (1899), 261.

⁸ *J. Russ. Phys. Chem. Soc.* **43** (1911), 951.

⁹ *Repts. Osaka Imp. Ind. Res. Inst.* **19**, No. 4 (1938).

¹⁰ *J. prakt. Chem.* II, **60** (1899), 261.

¹¹ *Ber.* **28** (1895), 2705.

The Santolinenones

Francesconi and collaborators observed in oil of *Santolina chaemaecyparissus* L. the occurrence of three ketones which they named α -, β -, and γ -santolinenone. None of these ketones have been obtained in pure form and the suggested structural formulas remain quite doubtful. The γ - isomeride is probably bicyclic.

*α-Santolinenone*C₁₀H₁₆O

Mol. Weight 152.23

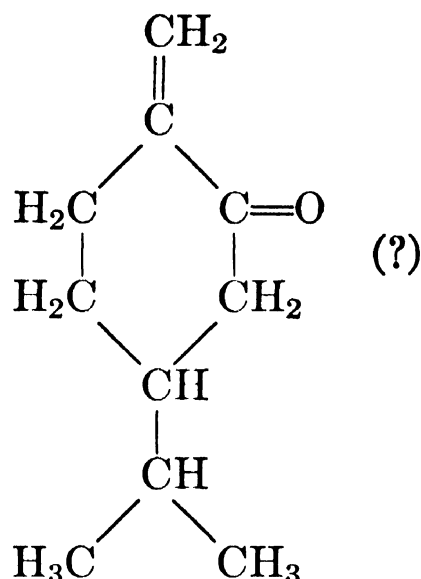
1(7)-*p*-Menthen-2-one. 1-Methylene-4-isopropylcyclohexan-2-one

This ketone was described by Francesconi and Scarafia.¹ It forms a hydroxylamino-oxime m. 190°, according to Francesconi and Granata.²

¹ *Atti accad. Lincei* [5], **20**, II (1911), 318. *Chem. Abstracts* **6** (1912), 230.

² *Gazz. chim. ital.* **45**, I (1915), 170.

*β-Santolinenone*C₁₀H₁₆O

Mol. Weight 152.23

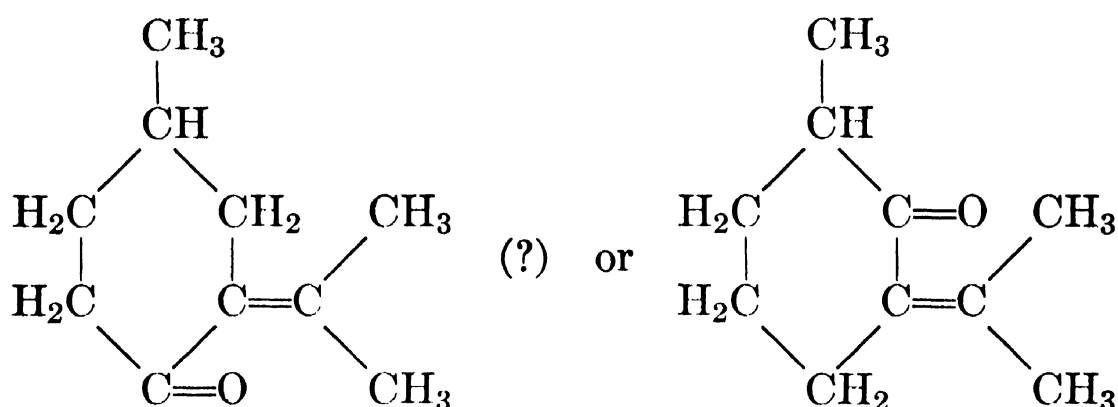
3(8)-*m*-Menthen-4-one. 1-Methyl-3-isopropylidenecyclohexan-4-one.3(8)-*m*-Menthen-2-one. 1-Methyl-3-isopropylidenecyclohexan-2-one.

This ketone was described by Francesconi and Granata.¹ It forms a hydroxylamine m. 63°–64° which, like the liquid oxime, is volatile with steam. On oxidation with mercuric oxide, the hydroxylamine yields a nitroso-compound m. 60°–62°. The hydroxylamine cannot be hydrolyzed to the parent ketone.

¹ *Gazz. chim. ital.* **46**, II (1916), 251.

Carvenone

C₁₀H₁₆O

Mol. Weight 152.23

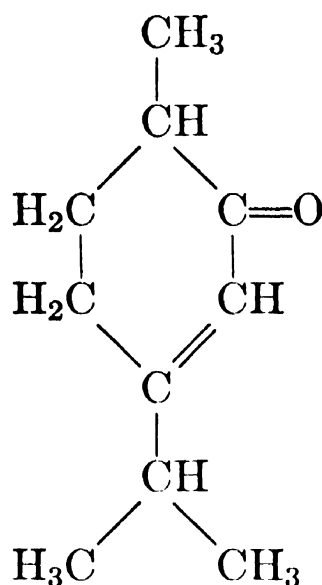
3-*p*-Menthen-2-one. 1-Methyl-4-isopropyl-3-cyclohexen-2-one

This ketone has not yet been found in essential oils. It is obtained by the action of concentrated sulfuric acid on camphor at 200°.

Identification.—The racemic oxime m. 91°–92° can be prepared quite easily but its melting point lies too close to that of carvone oxime or dihydrocarvone oxime.

The most suitable derivative for the characterization of carvenone is its hydroxyl-amino-oxime m. 167°–168°.

The semicarbazone exists in two modifications, the α - form melting at 202°–203°, the more soluble β - form at 153°–154°.

Properties.—Carvenone is a colorless oil possessing an odor similar to that of carvone. Auwers and Eisenlohr¹ reported these properties which are apparently typical as they confirm results of Wallach,² Bredt, Rochussen and Monheim,³ Brühl,⁴ and Crymble, Stewart, Wright and Rea:⁵

dl-Carvenone

b.	232°–233°	d ₄ ²⁰	0.9266
b ₇₅₈	235.5°–236° ⁵	n _D ²⁰	1.48245

On reduction with sodium and alcohol, carvenone yields carvomenthol, according to Wallach.⁶ Treibs⁷ found that the autoxidation of carvenone proceeds analogously to that of piperitone.

Use.—Carvenone has not found any noteworthy use in the perfume or flavor industries.

¹ *J. prakt. Chem.* [2], **82** (1910), 130; [2], **84** (1911), 19.

² *Liebigs Ann.* **286** (1895), 130.

³ *Ibid.* **314** (1901), 379.

⁴ *Ber.* **32** (1899), 1225.

⁵ *J. Chem. Soc.* **99** (1911), 1265.

⁶ *Liebigs Ann.* **277** (1893), 130.

⁷ *Ber.* **65** (1932), 163.

Carvone

(Carvol)

 $C_{10}H_{14}O$

Mol. Weight 150.21

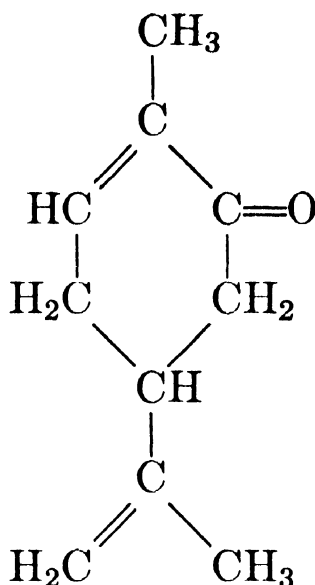
6,8(9)-*p*-Menthadien-2-one. 1-Methyl-4-isopropenyl-6-cyclohexen-2-one

Occurrence.—This important ketone occurs in several essential oils, in both the racemic and the optically active forms.

d-Carvone is the main constituent (50–60 per cent) of caraway seed and dill seed oil (*Anethum graveolens* L.). Dill herb oil contains a lesser percentage.

l-Carvone is the principal constituent of spearmint oil (up to 70 per cent), and also occurs in kuromoji oil.

dl-Carvone occurs in gingergrass oil.

Isolation.—(1) Carvone can be isolated from essential oils by taking advantage of the fact that this ketone, when shaken with a neutral solution of sodium sulfite, forms the water soluble sodium salt of a disulfonic acid $C_{10}H_{16}O_7S_2Na_2$, whereby the addition takes place at both of the ethylenic linkages. For this purpose the fraction b. 220° – 235° —for instance, of caraway seed oil—is shaken with the corresponding quantity of a concentrated aqueous solution of sodium sulfite, and the sodium hydroxide liberated during the reaction is neutralized from time to time with dilute acid. After completion of the process, the portions which have not entered the reaction are removed by extracting the solution repeatedly with ether. Finally the carvone is regenerated by the action of sodium hydroxide, and distilled off with steam.

(2) Carvone may be separated from essential oils, and identified, through the compound which it forms readily with hydrogen sulfide, $(C_{10}H_{14}O)_2 \cdot H_2S$. This can be achieved, according to Wallach,¹ by passing a current of hydrogen sulfide into an alcoholic solution of the ketone containing ammonia. The pure ketone may be regenerated from the hydrogen sulfide compound by digestion with alkali. Gildemeister and Hoffmann² recommended saturating a mixture of 20 parts carvone fraction, 5 parts alcohol, and 1 part ammonia (d_{15} 0.96) with hydrogen sulfide. The separated hydrogen sulfide compound is filtered off under suction, recrystallized from methyl alcohol, the carvone regenerated by boiling with alcoholic potassium, and purified by steam distillation. Harries³ reported for the *d*- and *l*- forms of the hydrogen sulfide compound a melting point of 224° – 225° , whereas Deussen⁴ claimed a melting point

of 210° – 211° ($[\alpha]_{\text{D}}^{18} + 48^{\circ} 43'$, $[\alpha]_{\text{D}}^{22} - 48^{\circ} 27'$, in 0.6% chloroform solution). The *dl*-form melts at 189° – 190° . The compound, according to Challenger,⁵ has been widely studied. A wide variation of properties has been reported.

Identification.—Carvone may be characterized by the preparation of several compounds:

(1) Through the hydrogen sulfide compound (see above, and also consult work of Taboury⁶).

(2) *d*-Carvone yields two semicarbazones m. 162° , $[\alpha]_{\text{D}}^{20} + 115^{\circ} 6'$ (in methyl alcohol) and m. 141° – 142° , $[\alpha]_{\text{D}}^{20} + 113^{\circ} 18'$ (in pyridine). The lower melting semicarbazone, according to Rupe and Dorschky,⁷ is unstable and passes into the higher melting form either on keeping or on heating to 170° – 175° . *l*-Carvone yields only the higher melting, stable semicarbazone. The *dl*-semicarbazone melts at 154° – 156° .

(3) According to Baeyer,⁸ carvone may be characterized by its phenylhydrazone m. 109° – 110° .

(4) The oximes of carvone have been thoroughly studied. *d*- or *l*-Carvoxime m. 72° , $[\alpha]_{\text{D}}^{17} + 39^{\circ} 43'$ (in alcohol), $[\alpha]_{\text{D}}^{18} - 39^{\circ} 21'$ (in alcohol), according to Wallach,⁹ is easily prepared by treating *d*- or *l*-carvone with hydroxylamine hydrochloride in methyl alcoholic solution. *dl*-Carvoxime melts at 92° – 93° . It can be obtained either from *dl*-carvone, or by the digestion of the active oximes with alcohol or ligroine, whereby racemization occurs.

For the preparation of carvoxime, Wallach¹⁰ recommended dissolving 50 g. of carvone in 250 cc. of alcohol, and adding to this solution, with shaking, a hot solution of 50 g. of hydroxylamine hydrochloride in 50 cc. of water. Into the clear liquid a warm solution of 50 g. of potassium hydroxide in 400 cc. of water is poured at once. The liquid becomes yellow and potassium chloride precipitates. Immediately after cooling, and without any further warming, the liquid is poured into cold water. The main portion of the carvoxime will precipitate in the form of solid flakes which should be collected on a filtering cloth and expressed. One hundred g. of dry carvoxime are recrystallized from 200 g. of hot alcohol, but before filtering some ether is added to the solution.

When preparing the carvoxime, care should be taken not to use too large an excess of hydroxylamine, as thereby also an addition compound of carvoxime with hydroxylamine, viz., $\text{C}_{10}\text{H}_{14}\text{NOH}\cdot\text{NH}_2\text{OH}$, m. 174° – 175° , would be formed. In case the freshly prepared carvoxime does not congeal soon, it may be brought to crystallization by steam distillation.

(5) Henze and Speer,¹¹ in their study of methods of identification of carbonyl compounds, characterized carvone by its conversion into a hydantoin m. 193.5° – 194° .

(6) Bowden and Watkins¹² discovered that the ether magnesium iodide complex with carvone $2\text{C}_{10}\text{H}_{14}\text{O}\cdot\text{MgI}_2\cdot\text{Eth}_2\text{O}$ yields two characteristic melting points: 1st 85° , 2nd 125° .

(7) A number of characteristic hydrazones of the *d*-isomer have been prepared: 2,4-dinitrophenylhydrazone, m. 189° (Allen¹³); 3-nitrobenzohydrazone m. 162° – 163° (Strain¹⁴); β -naphthylhydrazone m. 147° (Rothenfusser¹⁵); *p*-nitrophenylhydrazone m. 174° – 175° (Borsche, Witte and Bothe¹⁶).

Regarding the quantitative determination of carvone, consult Vol. I, Chapter 4, "The Examination and Analysis of Essential Oils, Synthetics, and Isolates," p. 283; see also p. 287 for the method of Stillman and Read.¹⁷

Properties.—Carvone is a colorless oil possessing a marked odor typical of caraway seed. Carvone congeals at very low temperature. Gildemeister

and Hoffmann¹⁸ reported the following properties for *d*- and *l*-carvone purified through their sulfite compounds:

d-Carvone (from caraway seed oil)

b ₇₅₅	230°	α _D	+59° 57'
b ₅₋₆	91°	n _D ²⁰	1.49952
d ₁₅ ¹⁵	0.9645		

l-Carvone (from spearmint oil)

b ₇₆₃	230°–231°	α _D	–59° 40'
d ₁₅ ¹⁵	0.9652	n _D ²⁰	1.4988

Apparently the more recent literature recognizes a slightly higher rotation for these optical isomers, viz., near ±62° (cf. Naves and Bachmann,¹⁹ also Doeuvre²⁰). Otherwise, numerous investigations of this ketone only seem to confirm the other properties.

Both forms are soluble in 17 volumes of 50 per cent alcohol, and in 4 volumes of 60 per cent alcohol.

dl-Carvone, according to Walbaum and Hüthig,²¹ has these properties:

b.	230°–231°
d ₁₅	0.9645
n _D ²⁰	1.5003

In connection with the properties of this ketone mention should be made of very accurate measurements of the boiling point as carried out by Kobe, Okabe, Ramstad and Huemmer.²²

Reduction of carvone to any one of several hydrogenated products may be used as an indirect method of identification inasmuch as carvone yields to hydrogenation by platinum, sodium and alcohol, alkaline zinc, or isopropyl aluminum. However, particular attention should be given, whenever a reductive technique is employed, to the fact that several methods often cause complete inversion in the nature of the optical sign. Sodium and alcohol produce *l*-dihydrocarveol from *l*-carvone, whereas catalytic hydrogenation always causes inversion in the optical activity, *l*-carvone yielding finally *d*-carvomenthol. A guide in connection with these operations may be had in the studies by Wallach,²³ and Wallach and Schrader,²⁴ and the more recent findings of Nagasawa²⁵ on Japanese mint oils.

Carvone is quite readily attacked by oxidizing agents. When shaken with air or oxygen in the presence of baryta water, carvone yields a yellow diketone, according to Harries.²⁶ With potassium permanganate the degradation is profound, the main product being hydroxyterpenylic acid C₈H₁₂O₅,

m. 190° – 192° , as shown by Tiemann and Semmler.²⁷ See also the later investigations by Treibs.²⁸

The bromination of carvone has been investigated by Wallach.²⁹ Bromination leads to a mixture of crystalline (*d*- and *l*- forms m. 120° – 122° ; *dl*- form m. 112° – 114°), and liquid tetrabromides which are probably stereoisomers. On further bromination, the crystalline tetrabromide yields a pentabromide (*d*- and *l*- form m. 86° – 87° ; *dl*- form m. 96° – 98°), while the liquid tetrabromide yields an isomeric pentabromide (*d*- and *l*- form m. 142° – 143° ; *dl*- form m. 124° – 126°).

All halogen derivatives of carvone can be reconverted into carvone by reduction with zinc in acetic acid solution.

With hydrogen chloride in acetic acid solution, carvone gives a monohydrochloride; with hydrogen bromide, carvone yields a *d*-carvone hydrobromide m. 32° . On warming, especially in the presence of a catalyst, these hydrohalides pass into carvacrol. Isomerization of carvone to carvacrol also takes place with nearly all dehydrating agents—for example, sulfuric acid, phosphoric acid, zinc chloride, alkalies, etc.

Abe³⁰ has found that a combination of hydrogen cyanide, hydrogen sulfide, and ammonia acting upon carvone yields certain crystalline thioamide derivatives. These compounds form very slowly but may be of use in the study of carvone where time is not a factor.

When exposed to light for several months, carvone is converted to an isomeric crystalline ketone, the so-called camphor-carvone.

Use.—Carvone is widely used for the flavoring of many kinds of food products and beverages, especially in kummel liqueurs. It also serves in mouth preparations, gargles, toothpastes, and pharmaceuticals.

¹ *Liebigs Ann.* **305** (1899), 224.

² "Die Ätherischen Öle," 3d Ed., Vol. I, 556.

³ *Ber.* **34** (1901), 1928.

⁴ *J. prakt. Chem.* [2], **90** (1914), 318.

⁵ *Ind. Chemist* **4** (1928), 315.

⁶ *Compt. rend.* **214** (1942), 764.

⁷ *Ber.* **39** (1906), 2113, 2372.

⁸ *Ber.* **27** (1894), 810.

⁹ *Liebigs Ann.* **246** (1888), 226.

¹⁰ *Ibid.* **275** (1893), 118.

¹¹ *J. Am. Chem. Soc.* **64** (1942), 522.

¹² *J. Chem. Soc.* (1939), 1961.

¹³ *J. Am. Chem. Soc.* **52** (1930), 2955.

¹⁴ *Ibid.* **57** (1935), 758.

¹⁵ *Arch. Pharm.* **245** (1907), 375.

¹⁶ *Liebigs Ann.* **359** (1908), 70.

¹⁷ *Perfumery Essential Oil Record* **23** (1932), 278.

¹⁸ "Die Ätherischen Öle," 3d Ed., Vol. I, 555.

¹⁹ *Helv. chim. acta* **29** (1946), 61.

²⁰ *Bull. soc. chim.* [5], **1** (1934), 198.

²¹ *J. prakt. Chem.* [2], **71** (1905), 463.

²² *J. Am. Chem. Soc.* **63** (1941), 3251.

²³ *Liebigs Ann.* **275** (1893), 114.

²⁴ *Ibid.* **279** (1894), 377.

²⁵ *J. Soc. Chem. Ind. Japan* **41** (Suppl. Binding) (1938), 252. *Chem. Abstracts* **33** (1939), 811. *Repts. Osaka Imp. Ind. Res. Inst.* **19**, No. 4 (1938). *Chem. Abstracts* **34** (1940), 219.

²⁶ *Ber.* **34** (1901), 2105.

²⁷ *Ber.* **28** (1895), 2148.

²⁸ *Ber.* **64** (1931), 2178; **65** (1932), 1314.

²⁹ *Liebigs Ann.* **286** (1895), 120.

³⁰ *Sci. Repts. Tokyo Bunrika Daigaku* **A3** (1939), 217. *Chem. Abstracts* **33** (1939), 3360.

SUGGESTED ADDITIONAL LITERATURE

John Read and Robert G. Johnston, "Researches in the Carvone Series." Part I. "Some Ketones and Amines," *J. Chem. Soc.* (1934), 226.

Piperitenone

$C_{10}H_{14}O$

Mol. Weight 150.21

1,4(8)-*p*-Menthadien-3-one. 1-Methyl-4-isopropylidene-1-cyclohexen-3-one

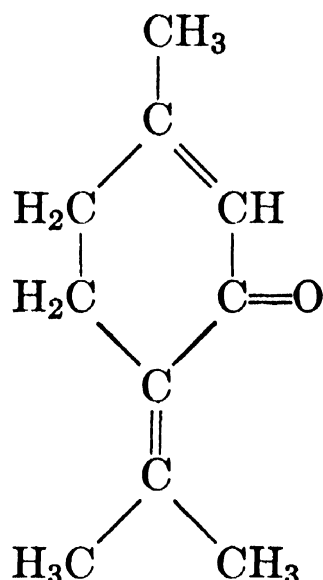

Occurrence.—Found by Naves¹ in Moroccan oil of pennyroyal (*Mentha pulegium* L. var. *eriantha*).

According to the same author,² piperitenone exists in the majority of oils from young pennyroyal plants harvested in damp places.

Isolation.—Compared with pulegone, piperitenone reacts more slowly with neutral sodium sulfite solution; the reaction should, therefore, be carried out on a boiling water bath for 3 hr. with continual shaking, preferably mechanical. The hydrogen sulfite compound is soluble in excess of sodium sulfite solution and can be regenerated by the action of alkalis. Piperitenone combines slowly with hydroxylamine.

Identification.—Piperitenone can be hydrogenated to menthone and menthol. By the action of catalysts—such as nickel, palladium, or charcoal carrying palladium—and in the absence of hydrogen by mere heating, piperitenone is isomerized to thymol with good yield.

Moreover, Naves and Papazian³ report that this unsaturated ketone is readily converted by formic acid to 1-methyl-1-cyclohexen-3-one.

Properties.—Naves and co-workers^{4,5} describe the properties of this terpenic derivative as follows:

b_{10}	106° – 107° ⁴	d_4^{20}	0.9774 ^{4,5}
$b_{1.8}$	92° ⁵	α_D	$\pm 0^{\circ}$ ^{4,5}
		n_D^{20}	1.5294 ^{4,5}

Use.—Piperitenone, as such, has not found any use in the perfume or flavor industries.

¹ *Helv. Chim. Acta* **25** (1942), 732; **26** (1943), 162.

² *Perfumery Essential Oil Record* **35** (1944), 221, 224.

³ *Helv. Chim. Acta* **25** (1942), 1023.

⁴ *Perfumery Essential Oil Record* **35** (1944), 221, 224.

⁵ *Helv. Chim. Acta* **25** (1942), 1023.

Isopiperitenone

$C_{10}H_{14}O$

Mol. Weight 150.21

1,8(9)-*p*-Menthadien-3-one. 1-Methyl-4-isopropenyl-1-cyclohexen-3-one

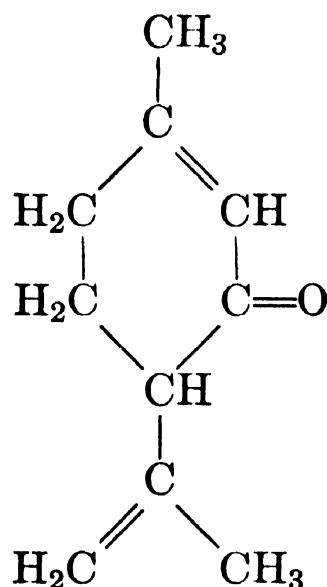

Occurrence.—Naves¹ found in the volatile oil derived from *Mentha pulegium* var. *Villona* Benth., growing in North Africa, a mixture of two isomeric ketones $C_{10}H_{14}O$, viz., piperitenone and isopiperitenone, the former comprising about 85 per cent of this mixture. The only direct proof of the presence of isopiperitenone in the ketone mixture was the formation of formaldehyde on ozonolysis.

Identification.—This ketone may be catalytically isomerized to thymol and hydrogenated to isomenthol which is readily identified (see “Isomenthol”).

Use.—Isopiperitenone is not used in our industries.

¹ *Helv. Chim. Acta* **25** (1942), 732.

(b) BICYCLIC TERPENE KETONES.

Fenchone

 $C_{10}H_{16}O$

Mol. Weight 152.23

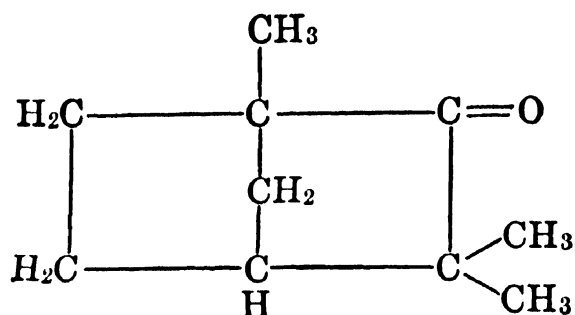

Occurrence.—*d*-Fenchone occurs in fennel seed oil (*Foeniculum vulgare*) and in oil of *Lavandula stoechas*, whereas its optical enantiomorph *l*-fenchone is a constituent of thuja oil (*Thuja occidentalis* L.). The ketone has also been reported in oils from a number of species of *Artemisia*.^{1,2}

Isolation.—Fenchone can be freed quite readily from impurities by taking advantage of its great stability toward oxidizing agents. For example, when gently warmed with nitric acid, fenchone is only slowly attacked. The fenchone thus obtained will be almost pure. Further purification may be achieved by crystallizing the ketone at low temperature.

d-Fenchone can easily be isolated from the fenchone-containing fractions of fennel oil. The fraction b. 190°–195° is gently heated with three times its weight of concentrated nitric acid until the color of the escaping, originally reddish-brown vapors fades. After cooling, the mixture is poured into water, the oil separated, washed with water, and steam distilled. However, this method does not eliminate small quantities of camphor which might be present, or that may be formed during the process of oxidation from esters of borneol.

According to Wallach,³ a complete separation of fenchone from camphor and other ketones can be effected by treatment with semicarbazide. The formation of the fenchonesemicarbazone requires several days, while the semicarbazone of camphor is formed more rapidly. For the preparation of the semicarbazone, Wallach recommended treating the fenchone in alcoholic solution at room temperature for two days with semicarbazide hydrochloride and sodium acetate. The alcohol and the fenchone which has not reacted are distilled off with steam. A single treatment will usually be sufficient to obtain a reasonably pure fenchone but, to prepare it in absolutely pure form, it is advisable to prepare and recrystallize the fenchonesemicarbazone and to decompose it with acids. This method has been confirmed by Dulou⁴ who finds that a week is sufficient to insure formation and separation.

Semmler⁵ suggested that fenchone and camphor be separated by boiling; then by distilling the two ketones over metallic sodium. Camphor forms sodium camphor, whereas fenchone, according to Wallach,⁶ is attacked much more slowly.

l-Fenchone may be isolated from thuja oil, according to Wallach,⁷ by shaking 130 g. of the oil fraction b. 190°–200° with a solution of 390 g. of potassium permanganate in 5 liters of water, and by steam distilling the mixture. Each 20 cc. of the oil layer distilled over is then boiled for 1 hr. with 80 g. of concentrated nitric acid and steam distilled. The *l*-fenchone thus obtained still contains small quantities of camphor but may be freed from it by the preparation of the semicarbazone, as described above.

Identification.—Fenchone can now be characterized by several derivatives. However, considerable attention should be paid in these directions to the element of time and to the technique of preparation.

(1) By the preparation of its semicarbazone which, however, is formed only very slowly. Wallach⁸ suggested the following method:

Dissolve 10 g. of semicarbazide hydrochloride and 10 g. of sodium acetate in 20 cc. of water and add a solution of 10 g. of fenchone in 50 cc. of alcohol. Keep the clear solution at room temperature for at least two weeks, then steam distill the product. The alcohol and free fenchone will distill over, while the semicarbazone in the residue will partly congeal to a compact mass, and partly crystallize from the hot water in which it is slightly soluble. From dilute alcoholic solutions the semicarbazone crystallizes in well formed, large, shiny rhombic prisms *m.* 182°–183°[(184°)⁹] for the *d*- and *l*-form. The *dl*-form melts at 172°–173° and does not possess the same capacity of crystallization.

(2) By the preparation of the oxime compound. These derivatives have been studied particularly by Delépine,¹⁰ Wallach,¹¹ and Hückel and Sachs¹² who are primarily responsible for these findings, also by Rabak,¹³ Ruzicka,¹⁴ and Komppa and Klami.¹⁵ The following table lists melting points and rotation:

			<i>d</i>		<i>l</i>	<i>dl</i>
Oxime	α	167°	$[\alpha]_D^{20}$	+46° 30' (in 96% alc.) ¹²	165° ^{11,13}	158°–160° ^{11,13,14,15}
	β	123°	$[\alpha]_D^{17.7}$	+148° 0' (in 96% alc.) ¹²	123° ¹⁰	129° ¹⁰
Benzoyloxime	α	81°	$[\alpha]_D^{20}$	+49° 0' (in 96% alc.) ¹²	79° ¹⁰	77° ¹⁰
	β	125°	$[\alpha]_D^{20}$	+128° 30' (in 96% alc.) ¹²	123° ¹⁰	111.5° ¹⁰

Wallach¹⁶ originally gave the following directions for the α -oxime preparation:

Add to a solution of 5 g. of fenchone in 80 cc. of absolute alcohol a solution of 11 g. of hydroxylamine hydrochloride and 6 g. of powdered potash in 11 g. of hot water. The oxime will crystallize after standing for one to two days, and when some of the alcohol has evaporated. The oxime may be purified by recrystallization from alcohol, acetic ether, or ether.

Although this procedure yields a satisfactory α -product, Vavon and Anziani¹⁷ later studied the optimum conditions for oximation of this ketone; they recommended different proportions with critical attention to pH where yield and speed of reaction are important. These workers obtained high yields for their procedure only after 180 hr. of refluxing.

Fenchoneoxime is insoluble in alkalies; under the influence of acidic reagents the course of the reaction has been shown by Cockburn¹⁸ and Gandini¹⁹ to be one of dehydration and ring fission instead of hydrolysis with a resulting mixture of complex nitrogenous products.

Subsequent to Wallach's isolation of the active α -fenchoneoximes, Delépine modified the technique to obtain a β -oxime that could readily be thermally rearranged to the stable α -form. Hückel's work demonstrated the stability of both α - and β -benzoyloximes.

Delépine made these properties of the oximes the basis of a method of identification of fenchone in mixtures with camphor. To accomplish this, he suggested:

Prepare the oximes by heating an alcoholic solution of fenchone and hydroxylamine hydrochloride for 4–6 hr. in presence of excess sodium hydroxide. Isolate the β -fenchoneoxime *m.* 123° by diluting the alkaline solution; the camphoroxime will remain in solution. The rotatory power of the crude β -fenchoneoxime, according to Delépine, is always higher than $\pm 115^\circ$. The β -fenchoneoxime can be isomerized to the α -oxime which has an optical rotation of about $\pm 45^\circ$.

(3) Useful hydrazone derivatives have been prepared from the active forms although both Wallach ²⁰ at an early date and more recently Allen ²¹ reported fenchone indifferent to phenylhydrazines, which again serves to emphasize the nonreactivity of the carbonyl grouping in this compound:

2,4-Dinitrophenylhydrazone	m. 140° ²² (sinters at 125°)
<i>p</i> -Iodobenzoylhydrazone	m. 168°–169° ²³

Properties.—Fenchone is an oil with a camphoraceous odor and somewhat bitter flavor. The ketone is distinguished by its relatively low melting point; it crystallizes at low temperature. The following properties have been reported by Fischer, ²⁴ Hückel et al., ²⁵ Wallach, ^{26, 27} Bouchardat and Lafont, ²⁸ von Rechenberg, ²⁹ Zaitzev, ³⁰ Nametkin, ³¹ Schimmel & Co., ³² Ruzicka, ³³ and Kondakov and Lutschinin: ³⁴

	<i>d</i>	<i>l</i>	<i>dl</i>
b.	b. 193.5°–194° ^{29, 34} b ₁₀₀ 121.95° ²⁹ b ₂₀ 82.3° ²⁹ b ₁₀ 68.3° ²⁹	b. 193° ²⁸	b. 193° ³² b ₁₂ 72°–73° ³³
m.	6° ³⁴ 5°–6° ²⁶ 5.5° ²⁵	6.03° ²⁴	–18° to –16° ²⁸
d	d ₄ ^{20–21} 0.9449–0.9465 ^{30, 34}	d ₂₀ 0.948 ²⁷ d ₀ 0.962 ²⁸	d ₁₅ ¹⁵ 0.9501 ³²
α	[α] _D ²⁰ +66° 54' ²⁵ [α] _D ¹⁶ +69° 48' (in alc.) ²⁵ [α] _D ¹⁶ +65° 54' (in benz.) ²⁵	[α] _D ²³ –66° 56' ²⁷ (in alc. p = 14.32)	
n	n _D ²⁰ 1.4623 ^{31, 34}		n _D ²⁰ 1.4702 ³²

The chemical properties of fenchone indicate that this ketone is relatively stable and inert, being indifferent to halogen acids, bisulfite, cold permanganate; even prolonged treatment with nitric acid degrades the ketone only partially, according to Gardner and Cockburn, ³⁵ whereas the action of halogens, recently studied in detail by Briusova, ³⁶ is best promoted by catalysts and often does not lead to uniform products. The sluggishness of the carbonyl grouping toward the formation of many derivatives has already been treated in detail.

Use.—Fenchone serves mainly as an odor adjunct in room sprays and bath preparations of pine character. Small quantities are used also in certain artificial essential oils.

- ¹ Covello, *Bull. orto. botan. Univ. Napoli* **15**, II (1941), 61. *Chem. Zentr.* I (1942), 2072. *Chem. Abstracts* **37** (1943), 4855.
- ² Rabak, *Ber. Schimmel & Co.*, April (1912), 24. *Chem. Zentr.* I (1912), 1715.
- ³ *Liebigs Ann.* **353** (1907), 215; **369** (1909), 65.
- ⁴ *Bull. inst. pin* [2], No. 58 (1934), 173.
- ⁵ *Ber.* **40** (1907), 4591.
- ⁶ *Liebigs Ann.* **369** (1909), 65.
- ⁷ *Ibid.* **272** (1893), 102.
- ⁸ *Ibid.* **353** (1907), 211.
- ⁹ Henderson, Henderson and Heilbron, *Ber.* **47** (1914), 887.
- ¹⁰ *Compt. rend.* **178** (1924), 1721. *Bull. soc. chim.* [4], **35** (1924), 1330.
- ¹¹ *Liebigs Ann.* **259** (1890), 327; **263** (1891), 136; **272** (1893), 104; **276** (1893), 317; **315** (1901), 278; **362** (1908), 199.
- ¹² *Ibid.* **498** (1932), 166.
- ¹³ *Ber. Schimmel & Co.*, April (1912), 24.
- ¹⁴ *Ber.* **50** (1917), 1374.
- ¹⁵ *Ber.* **68B** (1935), 2001.
- ¹⁶ *Liebigs Ann.* **272** (1893), 104; **315** (1901), 278.
- ¹⁷ *Bull. soc. chim.* [5], **4** (1937), 2026, 2035.
- ¹⁸ *J. Chem. Soc.* **75** (1899), 501.
- ¹⁹ *Gazz. chim. ital.* **72** (1942), 232. *Chem. Abstracts* **37** (1943), 4381.
- ²⁰ *Liebigs Ann.* **263** (1891), 135.
- ²¹ *J. Am. Chem. Soc.* **52** (1930), 2955.
- ²² Brady, *J. Chem. Soc.* (1931), 756.
- ²³ Sah and Hsü, *Rec. trav. chim.* **59** (1940), 355.
- ²⁴ *Bull. soc. chim. Belg.* **49** (1940), 129. *Chem. Abstracts* **36** (1942), 324.
- ²⁵ *Liebigs Ann.* **549** (1941), 186. *Chem. Abstracts* **37** (1943), 104.
- ²⁶ *Ibid.* **263** (1891), 131.
- ²⁷ *Ibid.* **272** (1893), 103.
- ²⁸ *Compt. rend.* **126** (1898), 756.
- ²⁹ "Einfache und Fraktionierte Destillation," 2d Ed., Miltitz (1923), 251, 291.
- ³⁰ *J. Russ. Phys. Chem. Soc.* **45** (1913), 1578.
- ³¹ *Ibid.* **47** (1915), 1596. *Chem. Zentr.* II (1916), 253.
- ³² *Ber. Schimmel & Co.*, April (1910), 107.
- ³³ *Ber.* **50** (1917), 1374.
- ³⁴ *J. prakt. Chem.* [2], **62** (1900), 2.
- ³⁵ *J. Chem. Soc.* **73** (1898), 708.
- ³⁶ *J. Gen. Chem. U.S.S.R.* **10** (1940), 1462. *Chem. Abstracts* **35** (1941), 2878.

Isopenone

C₁₀H₁₆O

Mol. Weight 152.23

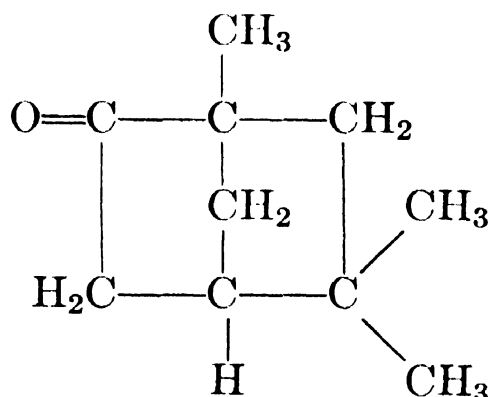

Occurrence.—Isopenone has not been found in nature.

Isolation.—*d*-Isopenone was prepared by Wallach¹ through oxidation of *d*-isopenyl alcohol, while *l*-isopenone was obtained by Bertram and Helle² through oxidation of *l*-isopenyl alcohol with chromic acid mixture.

(3) Useful hydrazone derivatives have been prepared from the active forms although both Wallach ²⁰ at an early date and more recently Allen ²¹ reported fenchone indifferent to phenylhydrazines, which again serves to emphasize the nonreactivity of the carbonyl grouping in this compound:

2,4-Dinitrophenylhydrazone	m. 140° ²² (sinters at 125°)
<i>p</i> -Iodobenzoylhydrazone	m. 168°–169° ²³

Properties.—Fenchone is an oil with a camphoraceous odor and somewhat bitter flavor. The ketone is distinguished by its relatively low melting point; it crystallizes at low temperature. The following properties have been reported by Fischer, ²⁴ Hückel et al., ²⁵ Wallach, ^{26, 27} Bouchardat and Lafont, ²⁸ von Rechenberg, ²⁹ Zaitzev, ³⁰ Nametkin, ³¹ Schimmel & Co., ³² Ruzicka, ³³ and Kondakov and Lutschinin: ³⁴

	<i>d</i>	<i>l</i>	<i>dl</i>
b.	b. 193.5°–194° ^{29, 34} b ₁₀₀ 121.95° ²⁹ b ₂₀ 82.3° ²⁹ b ₁₀ 68.3° ²⁹	b. 193° ²⁸	b. 193° ³² b ₁₂ 72°–73° ³³
m.	6° ³⁴ 5°–6° ²⁶ 5.5° ²⁵	6.03° ²⁴	–18° to –16° ²⁸
d	d ₄ ^{20–21} 0.9449–0.9465 ^{30, 34}	d ₂₀ 0.948 ²⁷ d ₀ 0.962 ²⁸	d ₁₅ ¹⁵ 0.9501 ³²
α	[α] _D ²⁰ +66° 54' ²⁵ [α] _D ¹⁶ +69° 48' (in alc.) ²⁵ [α] _D ¹⁶ +65° 54' (in benz.) ²⁵	[α] _D ²³ –66° 56' ²⁷ (in alc. p = 14.32)	
n	n _D ²⁰ 1.4623 ^{31, 34}		n _D ²⁰ 1.4702 ³²

The chemical properties of fenchone indicate that this ketone is relatively stable and inert, being indifferent to halogen acids, bisulfite, cold permanganate; even prolonged treatment with nitric acid degrades the ketone only partially, according to Gardner and Cockburn, ³⁵ whereas the action of halogens, recently studied in detail by Briusova, ³⁶ is best promoted by catalysts and often does not lead to uniform products. The sluggishness of the carbonyl grouping toward the formation of many derivatives has already been treated in detail.

Use.—Fenchone serves mainly as an odor adjunct in room sprays and bath preparations of pine character. Small quantities are used also in certain artificial essential oils.

- ¹ Covello, *Bull. orto. botan. Univ. Napoli* **15**, II (1941), 61. *Chem. Zentr.* I (1942), 2072. *Chem. Abstracts* **37** (1943), 4855.
- ² Rabak, *Ber. Schimmel & Co.*, April (1912), 24. *Chem. Zentr.* I (1912), 1715.
- ³ *Liebigs Ann.* **353** (1907), 215; **369** (1909), 65.
- ⁴ *Bull. inst. pin* [2], No. 58 (1934), 173.
- ⁵ *Ber.* **40** (1907), 4591.
- ⁶ *Liebigs Ann.* **369** (1909), 65.
- ⁷ *Ibid.* **272** (1893), 102.
- ⁸ *Ibid.* **353** (1907), 211.
- ⁹ Henderson, Henderson and Heilbron, *Ber.* **47** (1914), 887.
- ¹⁰ *Compt. rend.* **178** (1924), 1721. *Bull. soc. chim.* [4], **35** (1924), 1330.
- ¹¹ *Liebigs Ann.* **259** (1890), 327; **263** (1891), 136; **272** (1893), 104; **276** (1893), 317; **315** (1901), 278; **362** (1908), 199.
- ¹² *Ibid.* **498** (1932), 166.
- ¹³ *Ber. Schimmel & Co.*, April (1912), 24.
- ¹⁴ *Ber.* **50** (1917), 1374.
- ¹⁵ *Ber.* **68B** (1935), 2001.
- ¹⁶ *Liebigs Ann.* **272** (1893), 104; **315** (1901), 278.
- ¹⁷ *Bull. soc. chim.* [5], **4** (1937), 2026, 2035.
- ¹⁸ *J. Chem. Soc.* **75** (1899), 501.
- ¹⁹ *Gazz. chim. ital.* **72** (1942), 232. *Chem. Abstracts* **37** (1943), 4381.
- ²⁰ *Liebigs Ann.* **263** (1891), 135.
- ²¹ *J. Am. Chem. Soc.* **52** (1930), 2955.
- ²² Brady, *J. Chem. Soc.* (1931), 756.
- ²³ Sah and Hsü, *Rec. trav. chim.* **59** (1940), 355.
- ²⁴ *Bull. soc. chim. Belg.* **49** (1940), 129. *Chem. Abstracts* **36** (1942), 324.
- ²⁵ *Liebigs Ann.* **549** (1941), 186. *Chem. Abstracts* **37** (1943), 104.
- ²⁶ *Ibid.* **263** (1891), 131.
- ²⁷ *Ibid.* **272** (1893), 103.
- ²⁸ *Compt. rend.* **126** (1898), 756.
- ²⁹ "Einfache und Fraktionierte Destillation," 2d Ed., Miltitz (1923), 251, 291.
- ³⁰ *J. Russ. Phys. Chem. Soc.* **45** (1913), 1578.
- ³¹ *Ibid.* **47** (1915), 1596. *Chem. Zentr.* II (1916), 253.
- ³² *Ber. Schimmel & Co.*, April (1910), 107.
- ³³ *Ber.* **50** (1917), 1374.
- ³⁴ *J. prakt. Chem.* [2], **62** (1900), 2.
- ³⁵ *J. Chem. Soc.* **73** (1898), 708.
- ³⁶ *J. Gen. Chem. U.S.S.R.* **10** (1940), 1462. *Chem. Abstracts* **35** (1941), 2878.

Isopenone

C₁₀H₁₆O

Mol. Weight 152.23

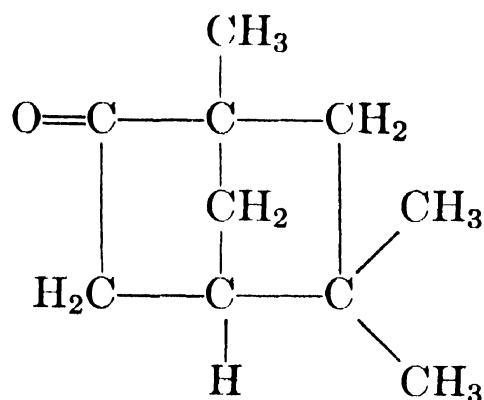

Occurrence.—Isopenone has not been found in nature.

Isolation.—*d*-Isopenone was prepared by Wallach¹ through oxidation of *d*-isopenchyl alcohol, while *l*-isopenone was obtained by Bertram and Helle² through oxidation of *l*-isopenchyl alcohol with chromic acid mixture.

Identification.—Isfenchone can be characterized directly or reduced to isofenchyl alcohol to form a number of derivatives as reported by Alder, Stein and Rickert,³ Komppa and Hasselström,⁴ Schmidt and Todenhöfer,⁵ Ruzhentseva and Delektorskaya,⁶ and Bertram and Helle:⁷

<i>Derivative</i>	<i>d</i>	<i>l</i>	<i>dl</i>
Semicarbazone	m. 221°–222° ⁵	221°–222° ⁵	223°–224° ⁵
Oxime	m. 82° ^{5,7}	82° ⁵	133° ³
Monobromo	m. 56°–57° ⁵	56°–57° ⁵	46°–47° ³
Hydrazone			m. 111°–112° ⁴
Acetyl Hydrazone			m. 193°–194° ⁴
Isofenchyl Alcohol (β)			b ₁₅ 89° ³
Isofenchyl Phthalate (β)			m. 104°–105° ³
Isofenchyl Phenylurethane (β)			m. 101° ³
Quinone			m. 49°–50° ³ m. 69°–70° ⁶

Properties.—Isfenchone is an oil possessing an odor which resembles that of camphor. At low temperature isfenchone forms an amorphous solid mass. Oxidizing α -isfenchol m. 61°–62° with bichromate-sulfuric acid mixture and purifying the optically active isfenchone thus obtained through its semicarbazone, Schmidt and Todenhöfer⁸ obtained pure isfenchone which had these properties:

b.	193°–194°	α_D	–8° 20'
d_{15}^{15}	0.949	n_D^{20}	1.46191

With the exception of the boiling point which was observed as 200°–201° and rotations ranging from absolute values –6° 41' to –9° 35', the properties cited above conform to those reported earlier by Nametkin,⁹ Wallach and Vivck,¹⁰ and Bertram and Helle¹¹ for the optically active forms.

Use.—Isfenchone, as such, is not used in our industries.

¹ *Liebigs Ann.* **357** (1907), 56.

² *J. prakt. Chem.* II, **61** (1900), 303.

³ *Liebigs Ann.* **525** (1936), 221, 242.

⁴ *Liebigs Ann.* **496** (1932), 164.

⁵ *Ber. Schimmel & Co.* (1937), 111. Cf. Wallach, *Liebigs Ann.* **362** (1908), 194, 200.

⁶ *J. Gen. Chem. U.S.S.R.* **10** (1940), 1653. *Chem. Abstracts* **35** (1941), 3246.

⁷ *J. prakt. Chem.* II, **61** (1900), 303.

⁸ *Ber. Schimmel & Co.* (1937), 111.

⁹ *J. Russ. Phys. Chem. Soc.* **47** (1915), 1598, 1601.

¹⁰ *Liebigs Ann.* **362** (1908), 195.

¹¹ *J. prakt. Chem.* II, **61** (1900), 303.

Thujone

 $C_{10}H_{16}O$

Mol. Weight 152.23

3-Keto-sabinane

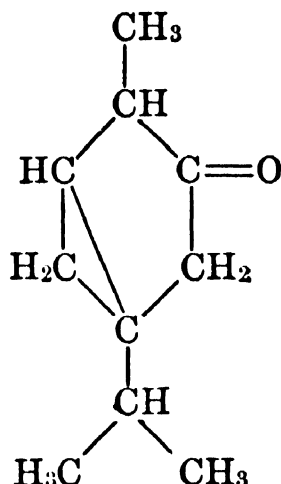

Thujone occurs in nature in the form of two diastereoisomers, viz., as laevorotatory " α -thujone" and as dextrorotatory " β -thujone," the latter being the "tanacetone" of Semmler. The behavior of the two isomers indicates that α - and β -thujone are not optical enantiomorphs, but stereoisomers of the same type as menthone and isomenthone. However, due to the pronounced tendency of α - and β -thujone to undergo inversion, especially under the influence of alkalis, it has only been through the comparatively recent work of Short and Read ¹ that stereochemically homogeneous thujones have been prepared for the first time. These pure isomers were then properly named as *l*-thujone and *d*-isothujone,* and the natural products α - and β -thujone were shown to be mixtures of these above-mentioned diastereoisomers in dynamic equilibrium.

Occurrence.—Thujone occurs in nature quite widely distributed. It forms the main constituent of several important volatile oils—for example, α -thujone in oil of thuja (*Thuja occidentalis*) and sage (*Salvia officinalis* L.), β -thujone in oil of tansy (*Tanacetum vulgare* L.), and wormwood (*Artemisia absinthium* L.). Thujone has been identified also in a number of less important oils.

Isolation.—Werner and Bogert ² reported the ready isolation of the natural α -thujone from thuja leaf oil of *Thuja occidentalis* by a single fractionation, whereas Rose and Livingston ³ succeeded in fractionating this ketone from the leaf oil of the Washington cedar (*Thuja plicata*).

Most workers, however, employed chemical methods for this step. Thus, Wallach and Böcker ⁴ isolated the α - isomer from a thuja oil fraction b. 200° – 204° by preparation of the semicarbazone and decomposition of this derivative with phthalic anhydride.

The β - isomer of the ketone can be isolated from oils containing a high percentage of thujone by taking advantage of the fact that it forms with sodium bisulfite a characteristic, sparingly soluble, compound $C_{10}H_{16}O$, $NaHSO_3$ from which the thujone can be regenerated by treatment with alkali.

* Not to be confused with the so-called "isothujone" of Wallach, *Liebigs Ann.* **286** (1895), 102.

For the separation of β -thujone from oil of tansy, Semmler ⁶ suggested shaking 200 cc. of tansy oil, 200 cc. of saturated sodium bisulfite solution, 75 cc. of water and 300 cc. of alcohol for two weeks. A part of the bisulfite compound will remain liquid for a long time but may be brought to crystallization when placed in a freezing mixture. The crystalline mass is then filtered under suction, pressed, washed first with alcohol-ether, then with ether and decomposed by the addition of sodium carbonate. Steam distillation will yield about 47% of the crude oil as β -thujone. Traces of aldehydes, where they exist, may be removed by treatment with ammoniacal silver nitrate and redistillation in steam.

Another similar type of compound is recommended by Gildemeister and Hoffmann. These authors suggested the ammonium bisulfite derivative.

A procedure to prepare this compound is the following:

Mix 200 g. of oil and 300 cc. of alcohol with 200 cc. of concentrated ammonium bisulfite solution and 75 cc. of water, set aside for two weeks, and shake frequently. Decompose the precipitated crystalline mass with soda solution and remove the regenerated thujone by steam distillation.

In cases where the amount of thujone may be small, even as little as 5 mg., recourse should be had to the method generally in use for absinthe-type liqueurs, viz., the semicarbazide reaction which has been critically assayed by Wilson.⁷

Identification.—Since it has been only recently shown that α - and β -thujone, as prepared by the methods used in the past, are, in truth, mixtures of *l*-thujone and *d*-isothujone the purity of the derivatives prepared at that time may also be questionable. In case of any doubt, the following compounds should be considered:

(1) Both α - and β -thujone can be characterized by the preparation of their tribromide $C_{10}H_{13}OBr_3$.

As Wallach ⁸ suggested: Dissolve in a large beaker 5 g. of thujone in 30 cc. of petroleum ether and add at once 5 cc. of bromine. After a few seconds a quite violent reaction will take place, accompanied by the development of much hydrogen bromide. After completion of the reaction, and as the solvent vaporizes, the tribromide will gradually precipitate in the form of a crystalline mass. Free the crystals from adhering oil by washing with cold alcohol, and recrystallize from hot acetic ether. The pure tribromide crystals melt at 121° – 122° (cf. Werner and Bogert ⁹).

On treatment with sodium ethylate or sodium methylate, this tribromide yields an ethyl ether $C_{10}H_{11}Br(OH)(OC_2H_5)$, m. 144° – 145° , and a methyl ether $C_{10}H_{11}Br(OH)(OCH_3)$, m. 156° – 157° .

(2) Both α - and β -thujone may also be characterized and distinguished by the preparation of their semicarbazones, according to Wallach.¹⁰

α -Thujone (*l*-thujone) yields both a crystalline semicarbazone m. 186° – 188° (usually m. 184.5° – 186° , if not absolutely pure), $[\alpha]_D^{14} + 59^{\circ} 30'$, and an amorphous semicarbazone m. 100° – 110° , the amorphous product also being dextrorotatory.

β -Thujone (*d*-isothujone) yields a dimorphic semicarbazone crystallizing in hexagons m. 174° – 175° , and rhombohedras m. 170° – 172° , the latter being the more stable form of the two modifications. $[\alpha]_D^{18} + 215^{\circ} 46'$ to $[\alpha]_D^{13} + 221^{\circ} 28'$.

The method for the preparation of this derivative from mixtures and the optical properties of the derived semicarbazone of β -thujone by petrographic methods have been studied by Wilson and Keenan ¹¹ who found these constants useful for characterization of the ketone.

The variations in properties noted above suggest mixtures, but they have been included to show that derivatives of reliable melting point may nevertheless be isolated from a mixture of the natural products, viz., the α - and β -thujones, with patience in recrystallization. Moreover, the melting point and specific rotation of the semi-

carbazones of the optically pure *l*-thujone and *d*-isothujone are described by Short and Read¹² who found them to be quite similar, as regards melting point, to those obtained by Wallach.¹³

Pure l-Thujone

m. 186°–188°
 $[\alpha]_D^{14} +42^\circ 0'$ (c = 1 in methyl alcohol)

Pure d-Isothujone

m. 172°
 $[\alpha]_D^{15} +222^\circ 0'$ (c = 1 in methyl alcohol)

(3) By oxidation (see below).

(4) Several hydrazones have been prepared, according to Macbeth and Price,¹⁴ Strain,¹⁵ Werner and Bogert,¹⁶ Short and Read,¹⁷ and Ruzicka and Koolhaas,¹⁸ although the form of the parent substances is not always disclosed:

Derived from		m.	$[\alpha]_D^{16}$
?	2,4-dinitrophenylhydrazone	116°–117° ¹⁴	...
?	2,4-dinitrophenylhydrazone	106°–107.5° ¹⁵	...
Distilled α -thujone	2,4-dinitrophenylhydrazone	106°–107° ¹⁶	...
Optically pure <i>l</i> -thujone	2,4-dinitrophenylhydrazone	117° ¹⁷	+44° 0' (c = 1 in chloroform) ¹⁷
Optically pure <i>d</i> -isothujone	2,4-dinitrophenylhydrazone	116° ¹⁷	+161° 0' (c = 1 in chloroform) ¹⁷
Syn. β -thujone	2,4-dinitrophenylhydrazone	113°–114° ¹⁸	...
Natural β -thujone	2,4-dinitrophenylhydrazone	114°–115° ¹⁸	...
Syn. β -thujone	<i>p</i> -nitrophenylhydrazone	148°–150° ¹⁸	...
Natural β -thujone	<i>p</i> -nitrophenylhydrazone	148°–150° ¹⁸	...
?	3-nitrobenzohydrazone	156°–156.3° ¹⁶	...

Strain¹⁹ reports that the original carbonyl compounds may be regenerated from the hydrazones by treatment with dicarbonyls, such as methyl glyoxal and diacetyl in water, or with aqueous acids or glacial acetic acid.

Properties.—Thujone is a colorless, mobile oil possessing a characteristic odor.

The following properties have been reported for the thujones:

α -Thujone from Thuja oil, regenerated by Wallach and Böcker²⁰ from the semicarbazone with phthalic anhydride:

b.	200°–201°	$[\alpha]_D$	–10° 14'
d	0.912	n_D^{22}	1.4503

An optical rotation $\alpha_D -10^\circ 23'$ was observed by Paolini²¹ who decomposed the semicarbazone of α -thujone with phthalic anhydride and isolated the regenerated thujone by steam distillation. When heating the mixture of semi-

carbazone and phthalic anhydride on a steam bath for a half hour, Paolini obtained *d*- α -thujone $\alpha_D +10^\circ 23'$, inversion having taken place.

Werner and Bogert,²² Rose and Livingston,²³ Godchot,²⁴ and Short and Read²⁵ report constants slightly different from the above. However, these workers relied upon fractionation in the preparation of their distillates, the properties of which follow:

b.	198°–203° ²²	α_D^{15}	$-13^\circ 3' 25$
	199°–201° ²⁴	$[\alpha]_D^{20}$	$-11^\circ 35' 23$
b ₄₀	103°–104° ²³	n_D^{25}	1.4521 ²²
b ₈	72°–74° ²⁵	n_D^{20}	1.4530 ²³
d ₂₀	0.9152 ²³	n_D^{17}	1.4546 ²⁴
d ₁₅	0.9190 ²⁴		1.4590 ²⁵

β -Thujone, produced on a large scale by Schimmel & Co.,²⁶ and boiling in the same range as the α - isomer had these properties:

d_{15}^{15}	0.9209–0.9217
α_D	$+68^\circ 16'$ to $+70^\circ 58'$
n_D^{20}	1.44962–1.45422
Sol.	Soluble in about 10 vol. of 60% alcohol, and 2.5 to 3 vol. of 70% alcohol

For β -thujone regenerated from the semicarbazone, a rotation of $[\alpha]_D +76^\circ 10'$ was found.

The work of Short and Read,²⁷ however, has shown that both the α - and β -thujones, whether natural isolates or chemically derived as in the past, are but mixtures of two stereoisomers in dynamic equilibrium:

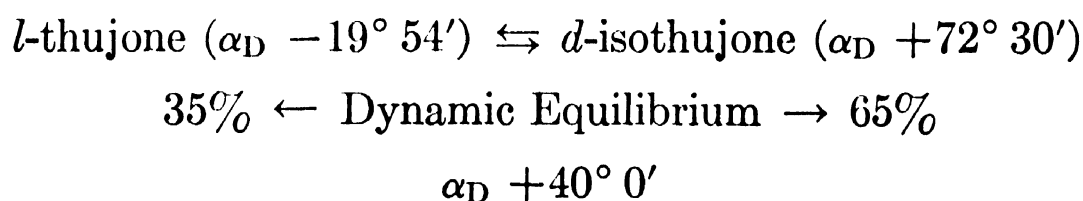

These workers have prepared optically homogeneous thujones for the first time by the chromic acid oxidation of thujyl alcohols. For these pure products, *l*-thujone and *d*-isothujone, they reported:

<i>l</i> -Thujone		<i>d</i> -Isothujone	
b_9	74.5°	b_{10}	76°
d_4^{25}	0.9109	d_4^{25}	0.9135
α_D^{18}	-19° 56'	α_D^{15}	+72° 28'
$[R_L]_D$	{ Obs. 44.77 Calc. 44.11	$[R_L]_D$	{ Obs. 44.72 Calc. 44.11
n_D^{25}	1.4490	n_D^{25}	1.4500
2,4-Dinitrophenylhydrazone:		2,4-Dinitrophenylhydrazone:	
m.	117°	m.	116°
$[\alpha]_D^{16}$	+44° 0' (c = 1 in chloroform)	$[\alpha]_D^{16}$	+161° 0' (c = 1 in chloroform)
Semicarbazone:		Semicarbazone:	
m.	186°-188°	m.	172°
$[\alpha]_D^{14}$	+42° 0' (c = 1 in methyl alcohol)	$[\alpha]_D^{15}$	+222° 0' (c = 1 in methyl alcohol)

Thujone shows a somewhat high molecular exaltation (+0.66). Chugaev and Chesno,²⁸ studying the rotatory characteristics of essential oils and their constituents, observed a very high dispersion coefficient for β -thujone (2.05) and suggested the use of this constant in characterizing the ketone.

Although a saturated ketone, thujone is easily oxidized with potassium permanganate to α - and β -thujaketonic acids.

The prefixes α - and β - in connection with the acids, however, do not necessarily refer to products derivable only from α - and β -thujones; in fact, both acids may be derived from either ketone. Tiemann and Semmler²⁹ showed

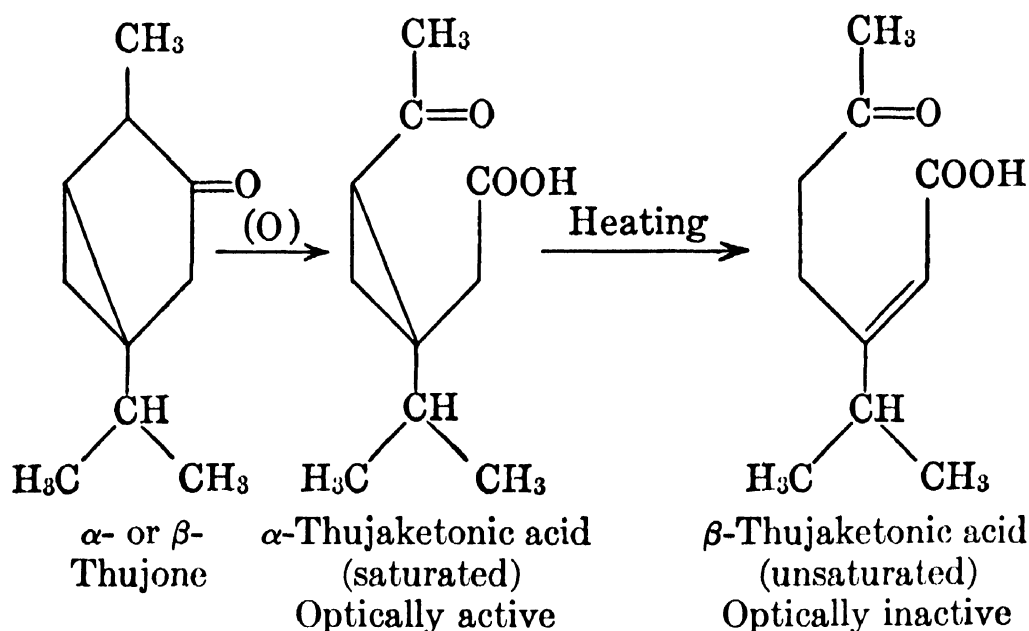

that at low temperature and with dilute potassium permanganate solution, only α -thujaketonic acid m. 75°-76° is formed and almost quantitatively. (In this connection, consult the work of Thomson,³⁰ Werner and Bogert,³¹

Ruzicka and Koolhaas.³²) This saturated α -thujaketonic acid $C_{10}H_{16}O_3$ forms a semicarbazone m. 183° – 184° (m. 198.5° according to Seyler³³), and an oxime m. 174° – 175° according to Thomson.³⁴ On heating or on distilling *in vacuo*, the α -thujaketonic acid is isomerized to the unsaturated β -thujaketonic acid m. 78° – 79° .

Oxidation with sodium hypobromite yields a stable dicarboxylic acid (viz., α -thujadicarboxylic acid m. 141° – 142° which forms an anhydride m. 55° – 56°), and β -thujadicarboxylic acid m. 116° – 117° .

Aside from oxidation, other reactions, too, prove the instability of the cyclopropane ring in thujone. Thus, Semmler³⁵ showed that when heated to 200° under pressure, thujone is isomerized to carvotanacetone $C_{10}H_{16}O$. This reaction takes place even on prolonged boiling, as may be concluded from the lowering of the rotatory power. This property of cyclopropane ring stability is useful according to Wallach³⁶ and Thomson³⁷ in differential analysis of terpenes similarly constituted.

To halogen acids, thujone is stable, at least in the cold and in ethereal solution. Aqueous hydrochloric acid and other mineral acids isomerize thujone to the so-called "isothujone," of Wallach³⁸ (b. 230° – 231° , d 0.9285, n_D^{20} 1.48227) with formation of some *p*-cymene.

Use.—Thujone is used primarily in the compounding of synthetic (artificial) essential oils, such as sage, wormwood, etc.

¹ *J. Chem. Soc.* (1938), 2016.

² *J. Org. Chem.* **3** (1939), 578.

³ *J. Am. Chem. Soc.* **34** (1912), 201.

⁴ *Liebigs Ann.* **336** (1904), 263.

⁵ *Ber.* **25** (1892), 3343. See also *Schimmel Report*, April (1898). Deussen and Ziem, *J. prakt. Chem.* **90** (1914), 318.

⁶ "Die Ätherischen Öle," 3d Ed., Vol. I, 577.

⁷ *J. Assocn. Off. Agr. Chem.* **19** (1936), 120; **20** (1937), 151.

⁸ *Liebigs Ann.* **275** (1893), 179; **286** (1895), 109.

⁹ *J. Org. Chem.* **3** (1939), 578.

¹⁰ *Liebigs Ann.* **336** (1904), 254, 270.

¹¹ *J. Assocn. Off. Agr. Chem.* **13** (1930), 396.

¹² *J. Chem. Soc.* (1938), 2016.

¹³ *Liebigs Ann.* **336** (1904), 261.

¹⁴ *J. Chem. Soc.* (1935), 151.

¹⁵ *J. Am. Chem. Soc.* **57** (1935), 758.

¹⁶ *J. Org. Chem.* **3** (1939), 578.

¹⁷ *J. Chem. Soc.* (1938), 2016.

¹⁸ *Helv. Chim. Acta* **15** (1932), 948.

¹⁹ *J. Am. Chem. Soc.* **57** (1935), 758.

²⁰ *Liebigs Ann.* **336** (1904), 258, 264.

²¹ *Ann. chim. applicata* **15** (1925), 414.

²² *J. Org. Chem.* **3** (1939), 582.

²³ *J. Am. Chem. Soc.* **34** (1912), 201.

²⁴ *Compt. rend.* **158** (1914), 1807.

²⁵ *J. Chem. Soc.* (1938), 2016.

²⁶ Gildemeister and Hoffmann, "Die Ätherischen Öle," 3d Ed., Vol. I, 578.

²⁷ *J. Chem. Soc.* (1938), 2016.

- ²⁸ *Trans. Sci. Chem. Pharm. Inst. (Moscow)*, No. 19 (1928), 181. *Chem. Abstracts* **24** (1930), 5933.
- ²⁹ *Ber.* **30** (1897), 431. See also Semmler, *Ber.* **25** (1892), 3347. Wallach, *Liebigs Ann.* **272** (1893), 111.
- ³⁰ *J. Chem. Soc.* **97** (1910), 1502.
- ³¹ *J. Org. Chem.* **3** (1939), 578.
- ³² *Helv. Chim. Acta* **15** (1932), 944.
- ³³ *Ber.* **35** (1902), 552. See also Simonsen, *Indian Forest Records* **9** (1922), 293.
- ³⁴ *J. Chem. Soc.* **97** (1910), 1511.
- ³⁵ *Ber.* **27** (1894), 895.
- ³⁶ *Liebigs Ann.* **360** (1908), 86.
- ³⁷ *J. Chem. Soc.* **97** (1910), 1502.
- ³⁸ *Liebigs Ann.* **286** (1895), 102.

SUGGESTED ADDITIONAL LITERATURE

Yasuji Fujita, "Dehydrogenation of Thujone with Chloranil," *J. Chem. Soc. Japan* **63** (1942), 1441. *Chem. Abstracts* **41** (1947), 3175.

M. S. Muthanna and P. C. Guha (Dept. of Pure & Applied Chemistry, Indian Inst. of Sci., Bangalore), "Total Synthesis of Thujone," *Science and Culture* **11** (1945), 103. *Chem. Abstracts* **40** (1946), 1475.

Camphor

C₁₀H₁₆O

Mol. Weight 152.23

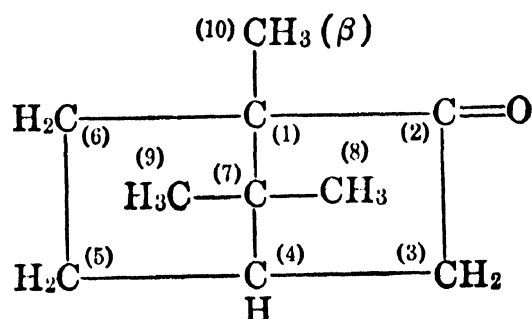

True camphor, also called Japan or China camphor, is a bicyclic ketone and must not be confused with the so-called "Borneo camphor," the latter being borneol; nor with "artificial camphor," which is an old term for terpene hydrochloride. For many years Formosa, Japan, and the adjacent coast of China held a world monopoly in the production of natural camphor but, due to a successful commercial synthesis and important technical demands, this ketone is today manufactured on a large scale. Space does not permit reviewing the many patents covering this field. Suffice it to mention only that most technical processes presently employed start from pinene (turpentine oil).

The principal reactions followed in this synthesis involve rearrangements under acidic influence as illustrated in the diagram on p. 430. Reviews of these processes have been given by Pond,¹ and more recently by Mayor.²

Occurrence.—Natural camphor, although produced in very large quantities from camphor oil (camphor tree), is not widely distributed in other volatile oils.

d-Camphor, by far the most important modification, occurs in the wood and leaves of the camphor tree, *Cinnamomum camphora* (Linné) Nees et Ebermaier (fam. *Lauraceae*), which grows wild and profusely in the moist, subtropical and tropical parts of Formosa, Japan, and southeastern China. The tree has been cultivated, but on an insignificant scale, also in other parts of the world, where suitable conditions of climate, soil, and altitude prevail. *d*-Camphor occurs also, but in much smaller proportions, in oils of sassafras, rosemary, spike lavender, Réunion basil, *Ocimum canum*, Dalmatian sage, etc.

l-Camphor has been found in oils of *Salvia triloba*, *Blumea balsamifera*, tansy, by Sokolova³ to the extent of 60–70 per cent in *Artemisia Austrachanica*, in amounts of nearly 50 per cent in *Lippa adoensis* from French West Africa by Laffitte and Rabaté,⁴ appreciable percentages in *Lavandula pedunculata* by Gattefossé and Igolen,⁵ and in a few other oils.

dl-Camphor occurs in oil of *Chrysanthemum sinense* var. *japonicum*. It has also been identified by Morani⁶ in oil of sage.

Camphor has furthermore been observed in a number of other volatile oils—in calamus oil and Seychelles cinnamon oil for example—and recently according to an anonymous authority⁷ in an African *Ocimum kilimandscharicum* oil of 77 per cent camphor content, but the literature does not specify which optical modification this camphor represents.

Isolation.—If an oil contains a large percentage of camphor, the latter may be separated quite easily by mere cooling or freezing. Otherwise, the oil must be fractionated and the camphor-containing fraction cooled. However, this technique should not be recommended, as shown some time ago by Simonsen and Ghose,⁸ in cases where the determination of yield is important as too much camphor remains dissolved in the rejected oily distillates. The raw camphor can readily be purified by sublimation. This is also done technically on a large scale.

Extraction or precipitation by means of acidic solvents has been successful in a qualitative way as this ketone apparently forms complexes that facilitate this reaction, even in essential oils. As a typical instance, Konovalov⁹ successfully isolated the camphor from oil of basil by fractional distillation and extraction by 80% sulfuric acid, whereas “Montecatini” patents¹⁰ register the use of the acetic acid complex which, upon dilution, precipitates camphor.

Identification.—Camphor may be characterized by a number of functional derivatives. Although many have been prepared for the dextrorotatory isomer and are useful for its identification they are not of particular value for the purpose of discrimination between the stereo forms. The active and racemic isomers too often possess very similar characteristics; hence only a few derivatives are important in the case of camphor. However, in recent years a restricted number of derived chemicals have been obtained, with distinctly different melting points among the stereo forms, that are of value for purposes of identification. Derivatives studied by Wheeler and Park,¹¹ Borsche and Merkwitz,¹² Morani,¹³ Patterson, Blackwood and Stewart,¹⁴ Brady,¹⁵ Taipale and Gutner,¹⁶ Little, M’Lean and Wilson,¹⁷ Woodward, Kolman and Harris,¹⁸ Sah and Hsü,¹⁹ Nametkin,²⁰ Kishner,²¹ Bredt and Perkin,²² Langlois,²³ Beckmann,²⁴ Tiemann,²⁵ Wheeler and Walker,²⁶ and Janot and Mouton,²⁷ are tabulated in the following table of melting points and specific rotation, emphasis being placed upon the complex semicarbazones:

Derivatives	<i>d</i>	<i>l</i>	<i>dl</i>
Semicarbazone	247°–248° ²² (corr.)
4- <i>m</i> -NO ₂ -phenylsemicarbazone	240°–242° ²⁶	240°–242°	...
Phenyl semicarbazone	153°–154° ¹²	153°–154° ¹³	171.5°–172.5° ¹³
α -Naphthyl semicarbazone	172.5° ¹³	172.5°	179°–180° ¹³
2- <i>p</i> -Cymyl-4-semicarbazone	217° ¹¹	217°	...
2,4-diNO ₂ -phenylhydrazone	175° ¹⁵	175°	164° ²⁷
<i>p</i> -Bromo-phenylhydrazone	101° ²⁵
Hydrazone	54°–55° ²⁰	54°–55°	...
Oxime	119° ²² , 119.6° ¹⁴ , 115° ²⁴	115° ²⁴	120° ²³
Azine	185° ^{16,21}	185°	...
<i>d</i> - δ (α -Phenylpropyl) semicarbazone	118° ¹⁷ [α] _D ¹⁴ –93° 36' (Alc. c = 0.828)	120° ¹⁷ [α] _D ¹⁴ –38° 48' (Alc. c = 1.1088)	104° ¹⁷ [α] _D ¹⁵ –61° 36' (Alc. c = 1.088)
<i>l</i> - δ (α -Phenylethyl) semicarbazone	112° ¹⁷ [α] _D ¹⁵ +41° 18' (Alc. c = 4)	112° ¹⁷ [α] _D ¹⁴ +102° 24' (Alc. c = 4.004)	122°–123° ¹⁷ [α] _D ¹⁵ +68° 54' (Alc. c = 4.004)
<i>l</i> -Menthylhydrazone	177°–178° ¹⁸ [<i>M</i>] _D ²⁵ –236° 0' (Alc. c = 0.0574)	193°–194° ¹⁸ [<i>M</i>] _D ²⁵ –101° 0' (Alc. c = 0.0574)	...
<i>p</i> -Iodobenzohydrazone	153°–154° ¹⁹

An important derivative is the 2,4-dinitrophenylhydrazone which has come to be recognized as a means of identification and as a quantitative determinative agent.

The pure ketone cannot be reconverted from the oxime.

For the identification of camphor in the presence of borneol, Haller²⁸ suggested that the mixture be heated with succinic or phthalic anhydride and alkalized, whereby the acid ester of borneol goes into solution. The camphor can then be extracted with ether from the alkaline solution. It is also possible to convert the borneol into high boiling esters, such as the succinate or the stearate, and to remove the camphor by steam distillation. As a third alternative, the camphor may be converted into its oxime and the latter dissolved in dilute sulfuric acid. The borneol may be removed by extraction with ether. In this case, however, the ethereal solution should in turn be shaken rapidly with dilute sulfuric acid as the ether dissolves also some of the oxime.

In order to distinguish natural camphor from synthetic camphor, Bohrisch²⁹ recommended the following reaction:

On careful heating to 30°, with a freshly prepared vanillin-hydrochloric acid solution (1 to 100), natural camphor develops a yellow, at 60° a blue-green, and at 75° to 80° an indigo-blue, color. The latter persists for several hours, even after cooling. By the same treatment, synthetic camphor gives a yellow color. After repeated recrystallization, the natural camphor no longer shows this reaction which permits the conclusion that the color reaction is caused by slight contamination of the camphor with constituents of camphor oil.

Properties.—Camphor is a granular-crystalline, colorless, transparent mass. It crystallizes in thin plates and easily sublimes, even at room temperature. Bridgman's³⁰ researches show camphor as one of the most complex polymorphic systems among all organic compounds, at least three of its forms existing at atmospheric pressures.

The continuous use of this ketone in the research laboratory as well as its industrial importance no doubt account for the fact that its physical constants have been redetermined many times. Certain points should be noted in connection with the physical properties. First, great similarity exists between certain of the characteristics for the active and racemic camphors *per se* and for their solutions, as melting point, boiling point, density, retroactive index and viscosity (Singh et al.³¹ and Plein and Poe³²). On the other hand the optical properties depend upon media, concentration, and temperature. Particular attention should be given to uniform conditions in determining the rotation. Alcohol is the solvent most frequently employed and its use has led to the development of empirical equations allowing of correction factors in terms of the variables of temperature, camphor concentration, and alcohol proof; the formulas of Schoorl³³ are typical of those used in such cases:

$$\begin{array}{ll} 70\% \text{ alcohol} & [\alpha]_D = 33.80 + 0.2c + 0.09t \\ 90\% \text{ alcohol} & [\alpha]_D = 37.05 + 0.145c + 0.09t \end{array}$$

Moreover the research worker will discover a helpful tabular summary of the many figures obtained for optical rotation on camphors in several media in Beilstein's "Handbuch der Organischen Chemie," Vol. VII E I, 78. In addition there are certain relevant contributions in the literature that should not be overlooked (Owen,³⁴ Plein and Poe,³⁵ and Beckmann and Cohen³⁶).

The following properties have been reported by Duncan,³⁷ Klemm, Tilk, and v. Müllenheim,³⁸ David and Novak,³⁹ Lenz,⁴⁰ Foerster,⁴¹ Landolt,⁴² Muncke,⁴³ Beckmann,⁴⁴ Haller,⁴⁵ Chautard,⁴⁶ Faucon,⁴⁷ Crane and Joyce,⁴⁸ LeFevre and Tideman,⁴⁹ and deWilde:⁵⁰

	<i>d</i>	<i>l</i>	<i>dl</i>
m.	179.4°–179.5° ^{48, 50} (corr.)
	178.7°–178.8° ^{40, 41, 47, 49} (corr.)	178.6° ⁴⁵ (corr.)	178.8° ⁴⁵ (corr.)
b.	207° ⁵⁰	204° ⁴⁶	...
d_4^{25}	0.9920 ³⁸		...
d_{20}	0.9940–0.9960 ³⁹		
$d_{15.5}$	0.9960 ³⁷	d_{18} 0.9853 ⁴⁶	
d_5^5	0.9998 ⁴³		
d_0^0	1.0000 ⁴³		
$[\alpha]_D^{20}$ (Alc.)	+43° 40' ⁴² (p = 15.09)	–44° 13' ⁴⁴ (p = 20)	...
	+44° 13' ⁴⁴ (p = 20)		

Camphor is readily soluble in organic solvents, in water at room temperature 1:598, and more sparingly soluble in warm water than in cold water, according to Leo and Rimbach.⁵¹

Camphor does not combine with bisulfite.

With potassium hydroxide in alcoholic solution, or more readily with metallic sodium in a neutral solvent, camphor is reduced to the stereoisomeric secondary alcohols, viz., borneol and isoborneol, according to Berthelot,⁵² and Baubigny.⁵³

Vavon and Peignier⁵⁴ found that, in the presence of platinum black, camphor can be hydrogenated at room temperature, the main product being isoborneol together with very little borneol. Prolonged hydrogenation yields camphane.

As a saturated bicyclic ketone, camphor is quite resistant to the action of oxidizing agents. Chromic acid attacks camphor only very slowly but, on prolonged heating, Kachler⁵⁵ obtained a mixture of mainly camphoronic acid and isocamphoronic acid.

Potassium permanganate in neutral solution does not attack camphor but, according to Grosser,⁵⁶ in alkaline solution yields camphoric acid.

Vene⁵⁷ recently prepared the quinone in 95 per cent yields by the action of selenium oxide in acetic anhydride on camphor.

Use.—Camphor is used very widely in countless medicinal preparations as a local anesthetic and remedy for rheumatic conditions, muscular strains, and similar inflammation. Internally it serves as a circulatory stimulant and as a calmative.

¹ *J. Soc. Chem. Ind.* **26** (1907), 383.

² *Chimie & industrie* **38** (1937), 20.

³ *Plasticheskie Massui* No. 5 (1934), 26. *Chem. Abstracts* **29** (1935), 3112.

⁴ *Chimie & industrie* **43** (1940), 365.

⁵ *Compt. rend.* **214** (1942), 885. *Chem. Abstracts* **38** (1944), 3777.

⁶ *Gazz. chim. ital.* **58** (1928), 404.

⁷ *Bull. Imp. Inst.* **39** (1941), 217. *Chem. Abstracts* **36** (1942), 615.

⁸ *J. Soc. Chem. Ind.* **39** (1920), 296T.

⁹ *Farmatsiya Farmakol.* No. 6 (1938), 8. *Chem. Abstracts* **34** (1940), 6764.

¹⁰ *Soc. gen. per l'industria mineraria ed agricola.* French Patent No. 808,057, Jan. 28; British Patent No. 474,097, Oct. 26; U. S. Patent No. 2,093,100, Sept. 14, 1937.

¹¹ *J. Am. Chem. Soc.* **51** (1929), 3079.

¹² *Ber.* **37** (1904), 3182.

¹³ *Gazz. chim. ital.* **58** (1928), 404.

¹⁴ *J. Chem. Soc.* (1933), 93.

¹⁵ *Ibid.* (1931), 756.

¹⁶ *Ber.* **63B** (1930), 243.

¹⁷ *J. Chem. Soc.* (1940), 336.

¹⁸ *J. Am. Chem. Soc.* **63** (1941), 120.

¹⁹ *Rec. trav. chim.* **59** (1940), 349.

²⁰ *J. Russ. Phys. Chem. Soc.* **47** (1915), 410.

²¹ *Ibid.* **43** (1911), 588.

²² *J. Chem. Soc.* **103** (1913), 2189.

²³ *Ann. chim.* [9], **12** (1919), 335.

- ²⁴ *Liebigs Ann.* **250** (1889), 355.
²⁵ *Ber.* **28** (1895), 2191.
²⁶ *J. Am. Chem. Soc.* **47** (1925), 2792.
²⁷ *J. pharm. chim.* **23** (1936), 547.
²⁸ *Compt. rend.* **108** (1889), 1308.
²⁹ *Pharm. Zentralhalle* **48** (1907), 527, 777; **55** (1914), 1003.
³⁰ *Proc. Am. Acad. Arts Sci.* **72** (1938), 227.
³¹ *Proc. Ind. Acad. Sci.* **5A** (1937), 484.
³² *Ind. Eng. Chem. Anal. Ed.* **16** (1944), 168.
³³ *Pharm. Weekblad* **64** (1927), 338.
³⁴ *Trans. Faraday Soc.* **26** (1930), 423.
³⁵ *J. Phys. Chem.* **38** (1934), 883. *J. Am. Pharm. Asscn.* **32** (1943), 89.
³⁶ *J. Chem. Phys.* **4** (1936), 784.
³⁷ *Pharm. J.* **119** (1927), 694.
³⁸ *Z. anorg. allgem. Chem.* **176** (1928), 10.
³⁹ *Magyar Gyogyyszerésztud Társaság Értesítője* **15** (1939), 344. *Chem. Abstracts* **33** (1939), 7485.
⁴⁰ *Arch. Pharm.* **249** (1911), 289.
⁴¹ *Ber.* **23** (1890), 2982.
⁴² *Liebigs Ann.* **189** (1877), 333.
⁴³ *Berzelius Jahresber.* **27** (1828), 453. Cf. Beilstein, VII (1925), 103.
⁴⁴ *Liebigs Ann.* **250** (1889), 352.
⁴⁵ *Compt. rend.* **103** (1886), 66; **105** (1887), 68.
⁴⁶ *Jahresber. Fortschritte Chem.* (1863), 555.
⁴⁷ *Compt. rend.* **154** (1912), 652.
⁴⁸ *J. Soc. Chem. Ind.* **26** (1907), 386.
⁴⁹ *J. Chem. Soc.* (1931), 1730.
⁵⁰ *Z. anorg. allgem. Chem.* **233** (1937), 411.
⁵¹ *Biochem. Z.* **95** (1919), 306. See also *J. Soc. Chem. Ind.* **38** (1919), 738A.
⁵² *Liebigs Ann.* **110** (1859), 368.
⁵³ *Compt. rend.* **63** (1866), 221.
⁵⁴ *Ibid.* **181** (1925), 184.
⁵⁵ *Ber.* **13** (1880), 487.
⁵⁶ *Ber.* **14** (1881), 2507.
⁵⁷ *Compt. rend.* **216** (1943), 772. *Chem. Abstracts* **38** (1944), 4576.

SUGGESTED ADDITIONAL LITERATURE

J. Houben and E. Pfankuch, "Camphor and Terpenes. Conversion of *d*-Camphor into *l*-Camphor (Preliminary Communication)," *Ber.* **64B** (1931), 2719. *Chem. Abstracts* **26** (1932), 1272.

Karl Meyer, "Der Kampfer," *Pharm. Ztg.* **81** (1936), 1180; **82** (1937), 73, 191. (Reviews.)

Seiichi Yamada, "Camphor, Borneol, and Allied Substances," *Bull. Chem. Soc. Japan* **16** (1941), 336. *Chem. Abstracts* **41** (1947), 4474.

Ken Wakatsuki, "The Estimation of Camphor. The Oxime Method," *J. Chem. Soc. Japan* **63** (1942), 559. *Chem. Abstracts* **41** (1947), 3257.

Eric D. Robinson and S. C. Werch, "The Determination of Camphor in Solution with Phenol in a High Percentage of Light Mineral Oil," *J. Am. Pharm. Asscn.* **36**, No. 9 (1947), 264.

Camphenilone

C₉H₁₄O

Mol. Weight 138.20

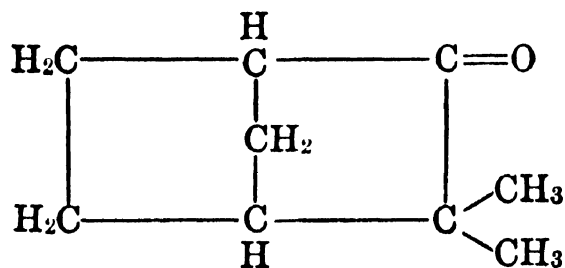

Occurrence.—Camphenilone does not occur in nature. However, it has been identified by several authors (Henderson and Sutherland,¹ Konovalov,² Aschan,³ Kumagae,⁴ and Cosciug⁵) among the oxidation products of camphene; and synthesis has been reported by Komppa and Komppa.⁶

Identification.—This terpenic ketone may be characterized by several well-defined derivatives of its stereoisomeric forms. These data by Snitter,⁷ Hüchel et al.,⁸ Lipp,^{9,10} Nametkin and Chuchrikova,¹¹ Nametkin, Grekova and Chuchrikova,¹² Wagner,¹³ Harries and Palmen,¹⁴ Komppa and Hintikka,¹⁵ Henderson and Sutherland,¹⁶ and Nametkin and Alexandroff¹⁷ are summarized in the following tables:

Derivatives	<i>l</i>	<i>d</i>	<i>dl</i>
Semi-carbazone	222°–224° (corr.) ⁹	m. 223°–225° ¹² m. 223° ⁸ [α] _D ¹⁷ +263° 0' ⁸ (in chloroform)	223°–224° (corr.) ^{7,10,14,15,17} 224°–225° ¹⁶
Oxime	...	2 compounds m. 115°–118° ⁸ [α] _D ¹⁸ +173° 0' ⁸ (in benzene)	m. 123° ⁸ [α] _D ²⁰ +160° 0' ⁸ (in benzene)
Hydrazone	...	m. 27°–28° ⁸ b ₈ 103°–103.5° ⁸ [α] _D ²⁰ +223° 24' ⁸ (in alcohol)	m. 29°–31° ¹¹ b ₇₅₃ 236°–238° ¹¹ b ₁₇ 119°–120° ¹¹
Azine	...	m. 142°–143° ⁸ [α] _D ²⁰ +304° 0' ⁸ (in benzene)	m. 148.5° ¹¹

Properties.—Camphenilone possesses a typical camphoraceous odor. It has been prepared in the dextro, laevo, and racemic form and no doubt the variations noted in the physicochemical properties recorded by a number of authors (Nametkin, Grekova and Chuchrikova,¹⁸ Langlois,¹⁹ Aschan,²⁰ Lipp,^{21,22} Snitter,²³ Hüchel et al.,²⁴ Nametkin and Chuchrikova,²⁵ Komppa

and Hintikka,²⁶ Henderson and Sutherland,²⁷ Bredt and Pinten,²⁸ and Heilbron and Bunbury²⁹) may be accounted for by the purity of the starting materials.

PROPERTIES

Isomeric Forms

	<i>d</i>	<i>l</i>	<i>dl</i>
b ₇₆₁	193° ²⁴
b.	190° ¹⁹	...	192° ²³
b.	191°–192° ²⁰	...	192°–194° ²⁵
b ₇₅₀	191.5°–192° ¹⁸
b ₁₆	...	76°–77° ²¹	...
b ₁₅	81° ²³
b ₁₂	75°–76° ²⁰
	78° ²⁴
b ₁₀	75° ²⁹
m.	36° ¹⁹	37°–38.5° ²¹	37° ²³
	39°–40° ¹⁸	...	35°–36° ²⁵
	41°–41.25° ²⁰	...	36° ²⁶
	38°–39° ²⁴	...	38°–39° (corr.) ²²
	40° ²⁷
d ₃₈	0.9705 ²⁹
d ₂₀	0.980 ²³
[α] _D	+70° 24' (in alcohol) ²⁴
[α] _D	+49° 10' (c = 6.6 in alcohol) ¹⁸
[α] _D ^{23.5}	+66° 42' (in benzene) ²⁴
[α] _D ¹⁹	...	–61° 13' (c = 10 in benzene) ²¹	...
[α] _D ¹⁸	...	–58° 39' ²⁸	...
n _D ²⁰	1.469 ²³

Camphenilone is most resistant to oxidizing agents but, on digestion with dilute nitric acid, it yields isocamphoronic acid.

With sodium and alcohol, camphenilone can be reduced to its corresponding secondary alcohol, viz., camphenilol m. 91.5°–92°, b₇₄₀ 192°, b₁₁ 88.5°–89°. This alcohol may be characterized by its phenylurethane m. 100°–102° according to Jagelki,³⁰ and 99.5° (Komppa³¹).

Use.—Camphenilone is not used in our industries.

¹ *J. Chem. Soc.* **99** (1911), 1547.

² *J. Russ. Phys. Chem. Soc.* II, **34** (1902), 43. See *Chem. Zentr.* I (1902), 1271, 1296.

³ *Liebigs Ann.* **375** (1910), 352; **383** (1911), 49. *Chem. Zentr.* I (1912), 415.

⁴ *J. Chem. Soc. Japan* **62** (1941), 326. *Chem. Abstracts* **37** (1943), 4382.

⁵ *Ann. sci. univ. Jassy*, Sect. I, **27** (1941), 303. *Chem. Zentr.* I (1943), 150.

⁶ *Ber.* **69B** (1936), 2606.

- ⁷ *Bull. inst. pin* [2], **46** (1933), 205.
⁸ *Liebigs Ann.* **549** (1941), 186. *Chem. Abstracts* **37** (1943), 103.
⁹ *Ibid.* **399** (1913), 250.
¹⁰ *Ibid.* **402** (1914), 360.
¹¹ *J. Russ. Phys. Chem. Soc.* **47** (1915), 427. *Liebigs Ann.* **438** (1924), 193.
¹² *J. Russ. Phys. Chem. Soc.* **48** (1916), 454.
¹³ *Ibid.* **28** (1896), 64, 76; **29** (1897), 124. Cf. Simonsen, "The Terpenes," Vol. II (1932) 301, 304.
¹⁴ *Ber.* **43** (1910), 1434.
¹⁵ *Ber.* **47** (1914), 1551.
¹⁶ *J. Chem. Soc.* **99** (1911), 1547.
¹⁷ *Liebigs Ann.* **467** (1928), 198.
¹⁸ *J. Russ. Phys. Chem. Soc.* **48** (1916), 454.
¹⁹ *Ann. chim. phys.* [9], **12** (1919), 271, 337.
²⁰ *Liebigs Ann.* **410** (1915), 233.
²¹ *Ibid.* **399** (1913), 250.
²² *Liebigs Ann.* **382** (1911), 290, 294, 297.
²³ *Bull. inst. pin* [2], **46** (1933), 205.
²⁴ *Liebigs Ann.* **549** (1941), 186. *Chem. Abstracts* **37** (1943), 103.
²⁵ *J. Russ. Phys. Chem. Soc.* **47** (1915), 427. *Liebigs Ann.* **438** (1924), 193.
²⁶ *Ber.* **47** (1914), 1551.
²⁷ *J. Chem. Soc.* **99** (1911), 1547.
²⁸ *J. prakt. Chem.* **119** (1928), 81.
²⁹ "Dictionary of Organic Compounds," Vol. I (1943), 381.
³⁰ *Ber.* **32** (1899), 1503.
³¹ *Liebigs Ann.* **366** (1909), 74.

Santenone

(π -Norcamphor)

$C_9H_{14}O$

Mol. Weight 138.20

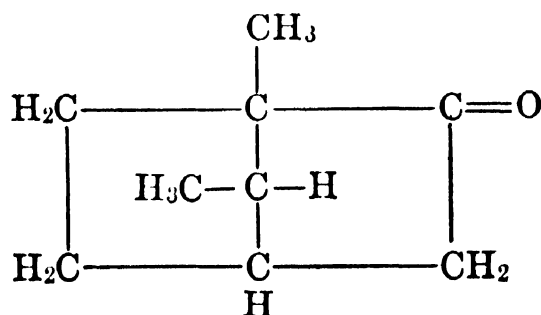

Semmler and Bartelt¹ prepared this bicyclic ketone synthetically and named it π -norcamphor. The structural formula suggested by these authors was later confirmed by Enkvist.²

Occurrence.—Schimmel & Co.³ identified *l*-santenone in East Indian sandalwood oil.

Isolation.—The fraction $b_{6.5}$ 65° – 80° (b. 180° – 200°) of East Indian sandalwood oil is treated with semicarbazide and the santenone regenerated through boiling of the semicarbazone with dilute sulfuric acid.

By taking advantage of the difference in solubility of the semicarbazones in alcohol and water, Aschan⁴ was able to separate certain stereoisomers of this ketone which he characterized as " α " and " β " * santenones.

* Authors are not always consistent in describing the same santenone and its derivatives as " α " and " β ." The nomenclature of Aschan has been maintained in this monograph.

	<i>m.</i> °C.	<i>Sol. in Alc.</i>	<i>Sol. in Water</i>
α -Santenone semicarbazone	235–236	0.6	2.5
β -Santenone semicarbazone	221–222	7.1	1.5

This author likewise recommended decomposition of the semicarbazones with oxalic acid as a means of obtaining pure " α " and " β " santenones.

Identification.—The isomeric " α " and " β " santenones designated according to the nomenclature of Aschan have been found by several workers to yield semicarbazones melting at 235°–236° and 222°–224°, respectively (cf. Schimmel & Co.,⁵ Rimini,⁶ Komppa and Nyman,⁷ and Ishidate and Sano⁸).

These stereoisomers yielding semicarbazones *m.* 235°–236° and 222°–224°, upon alkaline oxidation with potassium permanganate, form santenic acids melting respectively at 150°–151° and 170°–171° (cf. Ishidate and Sano,⁹ Komppa and Nyman,¹⁰ Aschan,¹¹ and Enkvist¹²). Both these *cis*- acids have been found to isomerize to the *trans*- forms *m.* 166°–167° and 129°–130°. Anhydrides derived from these *cis*- *trans*- forms melted at 93°–94° and 113°–114°.

Properties.—Schimmel & Co.¹³ reported for the *l*-santenone isolated from East Indian sandalwood oil:

<i>m.</i>	58°–61°	$[\alpha]_D$	–4° 24' (in alcohol)
<i>b.</i>	193°–195°	Semicarbazone <i>m.</i>	222°–224°

Ishidate and Sano¹⁴ recently prepared a relatively pure product which they have described as having the "*d*-*cis*- α configuration"; it had these properties:

<i>m.</i>	56°–59°
$[\alpha]_D^{22}$	+11° 24'
Semicarbazone <i>m.</i>	235°–236°

The purified " α " and " β " stereoisomers isolated by Aschan¹⁵ from crude santenone were characterized as follows:

α -Santenone		β -Santenone	
<i>m.</i>	55°–56°	<i>m.</i>	46°
<i>b</i> ₇₆₇	191°	<i>b.</i>	189.5°–190.5°
Semicarbazone <i>m.</i>	236°	Semicarbazone <i>m.</i>	221°–222°
Oxime	<i>m.</i> 74°	Oxime	<i>m.</i> 50°–51°

Use.—Santenone has not found any practical use in our industries.

¹ *Ber.* **40** (1907), 4467.

² *J. prakt. Chem. N.F.* **137** (1933), 261.

³ *Ber. Schimmel & Co.*, Oct. (1910), 98.

⁴ *Svensk Kem. Tid.* **45** (1933), 216.

⁵ *Ber. Schimmel & Co.*, Oct. (1910), 98.

⁶ *Gazz. chim. ital.* **43**, II (1913), 525.

⁷ *Ann. Acad. Sci. Fennicae* **A45**, No. 1 (1935). *Chem. Abstracts* **31** (1937), 6644.

⁸ *Ber.* **74B** (1941), 1189.

⁹ *Ibid.*

¹⁰ *Ann. Acad. Sci. Fennicae* **A45**, No. 1 (1935). *Chem. Abstracts* **31** (1937), 6644.

¹¹ *Svensk Kem. Tid.* **45** (1933), 209.

¹² *Finska Kemistsamfundets Medd.* **41** (1932), 74. *Chem. Abstracts* **27** (1933), 715.

¹³ *Ber. Schimmel & Co.*, Oct. (1910), 98.

¹⁴ *Ber.* **74B** (1941), 1189.

¹⁵ *Svensk Kem. Tid.* **45** (1933), 209.

Umbellulone

$C_{10}H_{14}O$

Mol. Weight 150.21

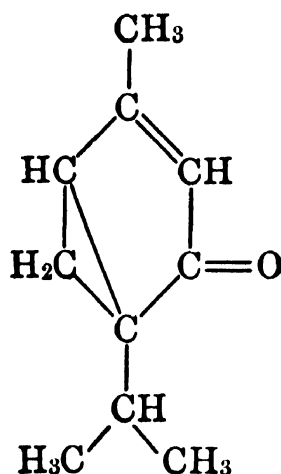

Occurrence.—The oil distilled from the leaves of the California laurel tree *Umbellularia californica* Nuttall contains from 30–40 per cent of this unsaturated bicyclic ketone.

Isolation.—(1) Umbellulone can be isolated by preparing the compound which it forms with sodium sulfite in neutral solution, and by regenerating the ketone through the action of alkali, according to Wienhaus and Todenhöfer.¹

(2) By fractional distillation of California laurel oil, separating the fraction b. 215°–216° or b₁₀ 92°–94°. Tutin² contends that this procedure yields an impure product which requires further treatment.

The ketone may be purified by the preparation of the semicarbazido-semicarbazone (see below) from which the carbonyl compound can be regenerated by hydrolysis with mineral acids.

Identification.—(1) With semicarbazide acetate, umbellulone yields a semicarbazido-semicarbazone m. 217° (with decomposition). For its preparation, Power and Lees³ suggested removing first the eugenol, by shaking the fraction b. 217°–222° of California laurel oil with potassium hydroxide solution. The fraction will then consist mainly of umbellulone. Mix a concentrated aqueous solution of 40 g. of semicarbazide hydrochloride and 50 g. of sodium acetate with 20 g. of the above-mentioned fraction and add methyl alcohol until the solution becomes clear. After standing for three days and after the addition of water, the semicarbazido-semicarbazone of the umbellulone will precipitate in the form of a white crystalline mass. Recrystallization from alcohol yields a semicarbazido-semicarbazone m. 216°–217°. Regenerate the umbellulone by the addition of a sufficient quantity of dilute sulfuric acid and distill with steam. Extract the umbellulone from the distillate by shaking with ether.

(2) The normal monosemicarbazone m. 240°–243° was prepared by Semmler.⁴

(3) Umbellulone can also be characterized by oxidation to umbellularic acid (1-isopropyl-1,2-cyclopropanedicarboxylic acid). When oxidized with potassium permanganate, umbellulone yields, according to Lees⁵ and Tutin,⁶ mainly a ketonic acid, viz.,

umbellulonic acid (2-acetyl-1-isopropylcyclopropanecarboxylic acid) $C_9H_{14}O_3$, m. 102° , b_{50} 193° – 195° , which can be identified by its oxime m. 169° – 170° . On distillation at atmospheric pressure, umbellulonic acid readily loses water and yields an unsaturated lactone $C_9H_{12}O_2$, b_{15} 99° – 100° , d_{20}^{20} 1.0197, $[\alpha]_D -210^\circ 35'$. Oxidation of this lactone with potassium permanganate gives a saturated dibasic acid, viz., umbellularic acid $C_8H_{12}O_4$, m. 120° – 121° , $[\alpha]_D -89^\circ 42'$ (in chloroform). This active acid has been shown by Rydon ⁷ to be identical with a synthetic *l-cis*-1-isopropylcyclopropane-1,2-dicarboxylic acid.

Properties.—Umbellulone is a colorless oil possessing a peculiar mint-like and extremely pungent odor, irritating to the mucous membranes. This ketone also has decided pharmacological action, according to Drake and Stuhr.⁸

Wienhaus and Todenhöfer ⁹ found the following properties for umbellulone purified through its sodium sulfite compound:

b_5	85°	α_D	$-38^\circ 51'$
d_{20}	0.949	n_D^{20}	1.48315
d_{15}	0.953		

Gillam and West ¹⁰ reported for umbellulone regenerated from its mono-semicarbazone with steam and phthalic anhydride:

b_3	69°	$[\alpha]_D$	$-36^\circ 0'$ (c = 1 in alc.)
d_{20}^{20}	0.950	n_D^{20}	1.4846

while umbellulone regenerated from its semicarbazido-semicarbazone had these properties:

b_3	72°	α_D	$-37^\circ 0'$
d_{15}^{15}	0.9518	n_D^{20}	1.4847

Umbellulone shows a very pronounced molecular exaltation (+1.4), due to the conjugation of the ethenoid linkage and the cyclopropane ring.

Use.—Umbellulone, as such, is not used in our industries.

¹ *Ber. Schimmel & Co. Jubiläums Ausgabe* (1929), 286.

² *J. Chem. Soc.* **93** (1908), 256.

³ *Ibid.* **85** (1904), 635. See also Gillam and West, *ibid.* (1945), 95.

⁴ *Ber.* **40** (1907), 5017; **41** (1908), 3988. See also Gillam and West, *J. Chem. Soc.* (1945), 95.

⁵ *J. Chem. Soc.* **85** (1904), 645.

⁶ *Ibid.* **89** (1906), 1104.

⁷ *Ibid.* (1936), 830.

⁸ *J. Am. Pharm. Assocn.* **24** (1935), 196.

⁹ *Ber. Schimmel & Co. Jubiläums Ausgabe* (1929), 288.

¹⁰ *J. Chem. Soc.* (1945), 98.

SUGGESTED ADDITIONAL LITERATURE

Y. R. Naves, "Sur la Structure de l'Umbellulone," *Helv. Chim. Acta* **28** (1945), 701.

Pinocamphone

 $C_{10}H_{16}O$

Mol. Weight 152.23

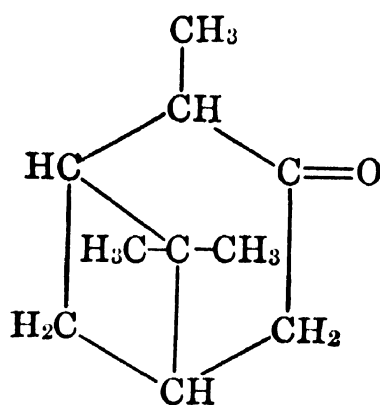

Occurrence.—According to Schimmel & Co.,¹ and Gildemeister and Köhler,² *l*-pinocamphone occurs in oil of hyssop (*Hyssopus officinalis*), of which it forms the main constituent (about 45 per cent). The dextrorotatory modification does not seem to occur in nature.

Isolation.—By fractional distillation of hyssop oil.

Recent investigations by Schmidt³ indicate that the pinocamphones and the stereoisomeric isopinocamphones are comparable to the menthol \rightleftharpoons isomenthol and thujone \rightleftharpoons isothujone series. They appear to exist together in dynamic equilibrium which is influenced by acids, alkalies, or catalysts. However, there are certain differences in the case of the pinocamphones. The direction of rotation is the same, but the rate of reaction with bromine differs, and similarly the rate of formation of the oximes is of different order. The pinocamphone oxime forms at the rate of 60% in 10 hr., while the isopinocamphone yields only 30%. This latter fact is of substantial assistance in the isolation of pure stereo forms.

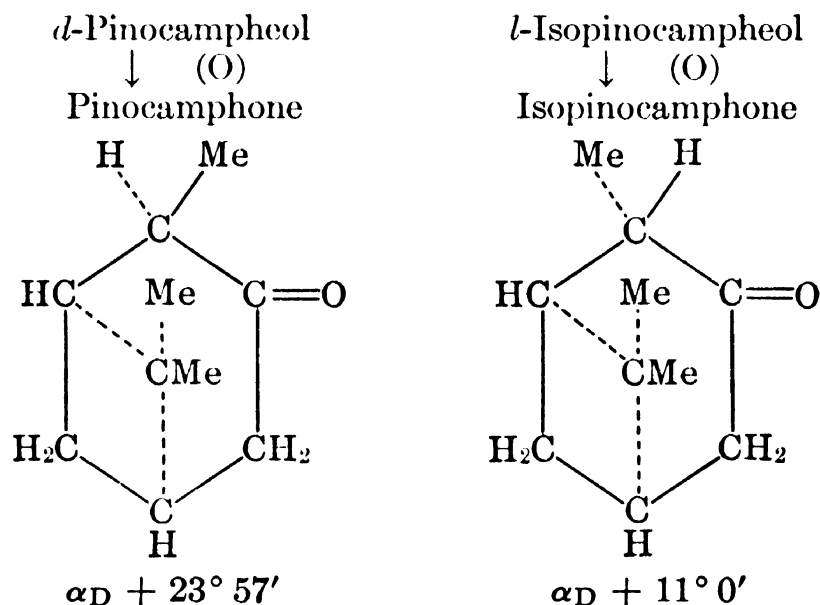

Identification.—*l*-Pinocamphone may be characterized by several methods:

(1) Treatment with bromine in glacial acetic acid at 0° yields first a crystalline dibromide $C_{10}H_{14}OBr_2$, the active forms, m. 95°–96°, according to Schmidt.⁴ The oily liquors therefrom, on steam distillation, gave the isomeric isopinocamphone dibromide, m. 113°–114°. The ketone may be readily regenerated from the dibromide by reduction with zinc dust in acetic acid solution.

(2) *l*-Pinocamphone, according to Gildemeister and Köhler,⁵ yields two semicarbazones, the α -form melting at 228°–229°, and the β -form melting at 182°–183°.

(3) Other derivatives of the pinocamphones are listed in connection with properties

Properties.—Pinocamphone is an oil with an odor reminiscent of camphor and thujone.

Gildemeister and Köhler,⁶ and Dulou⁷ reported these properties for natural *l*-pinocamphone from oil of hyssop:

b_{765}	212°–213° ⁶	α_D	–13° 42' ⁶
b_{22}	95° ⁷	n_D^{22}	1.4740 ⁷
d_{22}	0.960 ⁷	n_D^{20}	1.47421 ⁶
d_{15}^{15}	0.9662 ⁶		

Studying the stereoisomerism of pinocamphone, Schmidt and Schulz⁸ recorded the following properties:

	m.	b.	d_{15}^{15}	α_D	n_D^{20}	Melting Points	
						Oxime	Semi-carbazone
<i>cis-l</i> -Pinocamphone	...	212°	0.966	–17° 0'	1.47431
<i>cis-d</i> -Pinocamphone	About –35°	212°	0.966	+17° 54'	1.47456	...	219°
<i>cis-dl</i> -Pinocamphone	Liq.*	±0°	...	88°	...
<i>trans-l</i> -Pinocamphone	About –20°	211°	0.964	–22° 48'	1.47255	...	227°
<i>trans-d</i> -Pinocamphone	...	211°	0.964	+22° 30'	1.47260
<i>trans-dl</i> -Pinocamphone	Liq.*	±0°	...	89°	...
Pinocamphone (Wallach) †	Liq.	211°–213°	0.963	±0°	1.47270	86°–87°	208°

* The melting point was not determined.

† "Terpene und Campher," 2d Ed., 244.

These values were obtained by Schmidt before his investigation of the pinocamphone \rightleftharpoons isopinocamphone equilibria studies had been completed, and may be expected to change to a certain degree when more fully examined in the light of this work. Pinocamphones obtained by the same author⁹ after studying the effect of alkali, acids, and catalysts upon the stereoisomers of these ketones, had these properties:

<i>Pinocamphone</i>		<i>Isopinocamphone</i>	
b.	211°–211.5°	b.	213.5°–214°
b_5	70°–72°	b_5	70°
d_{15}^{15}	0.9643	d_{15}^{15}	0.9688
α_D	+23° 57'	α_D	+11° 0'
n_D	1.47279	n_D	1.47495
Mol. refr.	{ Obs. 44.21 Calc. 44.27	Mol. refr.	{ Obs. 44.17 Calc. 44.27
Semicarbazone	227°–228°	Semicarbazone	219°–220°
Oxime	55°–56°	Oxime	oil b. 125°

Use.—Pinocamphone is not used in our industries.

¹ *Ber. Schimmel & Co.*, April (1908), 120.

² *Wallach Festschrift* (1909), 421.

³ *Ber. Schimmel & Co.* (1941), 50. *Chem. Abstracts* **37** (1943), 4380.

⁴ *Ibid.*

⁵ *Wallach Festschrift* (1909), 421.

⁶ *Ibid.*

⁷ *Bull. inst. pin* (1934), 173.

⁸ *Ber. Schimmel & Co.* (1934), 99.

⁹ *Ber. Schimmel & Co.* (1941), 50. *Chem. Abstracts* **37** (1943), 4380.

Verbenone

C₁₀H₁₄O

Mol. Weight 150.21

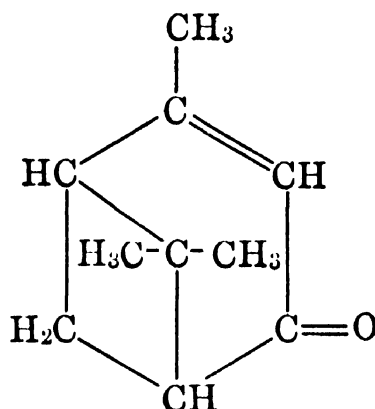

On autoxidation, α -pinene yields verbenone, verbenol being an intermediate product.

Occurrence.—For this reason, *d*- and *l*-verbenone frequently occur in old, oxidized dextro- and laevorotatory turpentine oils or in other oils containing a substantial quantity of pinene.

d-Verbenone is present to the extent of about 1 per cent in Spanish verbena oil (*Verbena triphylla* L.). It also occurs in Spanish *Eucalyptus globulus* oil.

Isolation.—(1) From autoxidized turpentine oils, verbenone is best isolated by fractional distillation and by treatment of the fraction b₅ 105°–107°, with semicarbazide-sodium acetate solution. The readily formed verbenone semicarbazone crystals are hydrolyzed with phthalic acid. The regenerated verbenone is steam distilled and thus obtained in pure form.

(2) A somewhat less satisfactory process consists in the preparation of the sodium sulfite derivative of verbenone in neutral solution, some loss occurring due to the formation of stable sulfonates. From the sodium sulfite compound, the ketone can be regenerated by the action of sodium carbonate. In Spanish verbena oil, verbenone occurs associated with citral *a* and citral *b*. These aldehydes should first be removed by condensation with cyanacetic acid.

For the isolation of verbenone from Spanish verbena oil, Kerschbaum¹ suggested the following method:

Shake 500 g. of Spanish verbena oil for two days with a solution of 900 g. of sodium sulfite and 350 g. of sodium bicarbonate in 2,500 g. of water, and extract repeatedly with ether. Decompose the sulfite solution with aqueous sodium hydroxide. A mixture of mainly citral and verbenone will be obtained. Shake this mixture with a solution of 5.5 g. of cyanacetic acid and 4 g. of sodium hydroxide in 30 g. of water, and

isolate the verbenone by extracting the mixture with ether. Acidify the residual alkaline solution and separate the citrylidenecyanacetic acid-*a* and -*b*.

The verbenone may finally be purified through the semicarbazone as described above.

Identification.—Verbenone can be identified:

(1) By the preparation of its semicarbazone, the *d*-form melting at 208°–209° (from alcohol) according to Kerschbaum,² the *dl*-form at 180°–181° according to Blumann and Zeitschel.³

(2) By the preparation of the oxime of *d*-verbenone m. 119°–120°, according to Wienhaus and Schumm.⁴ The formation of the oxamine-oxime m. 165° results from a slight excess of hydroxylamine according to these same authors; m. 163° according to Dupont and Zacharewicz.⁵

(3) According to Wienhaus and Schumm,⁶ the catalytic hydrogenation of *d*-verbenone with palladium-animal charcoal yields a saturated ketone, viz., *d*-verbanone C₁₀H₁₆O which can be characterized by the preparation of its oxime m. 88°.

Properties.—Verbenone is a viscid oil possessing an odor reminiscent of camphor, menthol, and celery. It crystallizes in the cold. On exposure to the air, the oil rapidly becomes yellow.

The following properties have been reported for verbenone:

d-Verbenone, obtained by Kerschbaum⁷ from Spanish verbena oil and purified through the semicarbazone:

b ₁₆	103°–104° (uncorr.)	[α] _D ¹⁸	+246° 0' ⁸
d ₁₇	0.974	n _D ¹⁷	1.49951

d-Verbenone, obtained by Blumann and Zeitschel⁹ through oxidation of *d*-α-pinene:

m.	+6.5°	d ₂₀	0.9780
b.	227°–228°	[α] _D	+249° 37'
b ₁₆	100°	n _D ¹⁸	1.49928

d-Verbenone, obtained by Wienhaus and Schumm¹⁰ from *d*-α-pinene from Greek turpentine oil:

b ₇₄₀	233°–234°	[α] _D	+217° 24'
b ₃₇	125°	n _D ²⁰	1.49557
d ₂₀	0.976		
d ₁₅	0.9795		

A high rotation has been reported by Schmidt, Schulz and Doll¹¹ on a product obtained by the oxidation of verbenol: α_D +250° 45'.

In a later investigation, Schulz and Doll¹² succeeded, by repeated recrystallization, in obtaining a *d*-verbenone of higher purity, possessing these properties:

cong. pt.	+9.8°	α _D	+273° 25'
d ₄ ²⁰	0.9754	n _D ²⁰	1.49649
d ₁₅ ¹⁵	0.9801		

This product yielded an oxime m. 120° – 121° , $[\alpha]_D +91^{\circ} 0'$ (in ether), and a semicarbazone m. 198° – 199° (see "Identification").

l-Verbenone does not seem to have been obtained in pure form.

Oxidation of *d*- and *l*-verbenone yields *d*- and *l*-pinononic acid which can be characterized by its semicarbazone m. 204° .

Use.—Verbenone is not used in our industries.

¹ *Ber.* **33** (1900), 886.

² *Ber.* **33** (1900), 889.

³ *Ber.* **46** (1913), 1194.

⁴ *Liebigs Ann.* **439** (1924), 32. See also Schmidt, Schulz and Doll, *Ber. Schimmel & Co.* (1940), 38. *Chem. Zentr.* II (1940), 3037.

⁵ *Bull. soc. chim.* [5], **2** (1935), 538.

⁶ *Liebigs Ann.* **439** (1924), 35, 37. See also Schmidt, Schulz and Doll, *Ber. Schimmel & Co.* (1940), 38. *Chem. Zentr.* II (1940), 3037.

⁷ *Ber.* **33** (1900), 889.

⁸ Original value given as $+66^{\circ}$. Observed and corrected, cf. Blumann and Zeitschel, *Ber.* **46** (1913), 1183.

⁹ *Ber.* **46** (1913), 1178.

¹⁰ *Liebigs Ann.* **439** (1924), 32. See also Schmidt, Schulz and Doll, *Ber. Schimmel & Co.* (1940), 38. *Chem. Zentr.* II (1940), 3037.

¹¹ *Ber. Schimmel & Co.* (1940), 38. *Chem. Zentr.* II (1940), 3037.

¹² *Ber. Schimmel & Co.* (1942/43), 50.

Pinocarvone

$C_{10}H_{14}O$

Mol. Weight 150.21

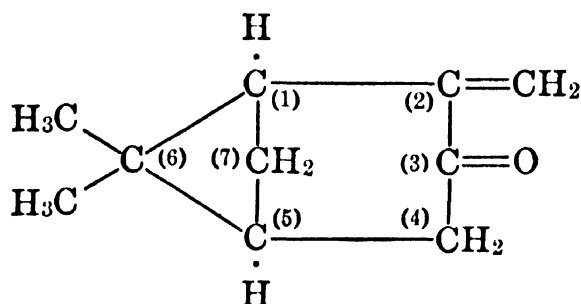

Occurrence.—According to Schmidt,¹ pinocarvone occurs in Spanish oil of *Eucalyptus globulus*.

Isolation.—Being an α,β -unsaturated ketone, pinocarvone reacts with neutral sulfite, but complete regeneration of the parent ketone from its sulfite addition compound can be achieved only with strong alkalies. Thus pinocarvone can be separated from accompanying myrtenal, the sulfite of which is decomposed, even by the addition of weak alkalies such as sodium carbonate. Schmidt² recommended the following procedure:

Shake, in the usual way, one 1 kg. of last runs of eucalyptus oils containing 10–15% ketones (hydroxylamine determination) with neutral sodium sulfite solution and bicarbonate. After separation of the neutral oil, steam distill the sulfite solution (soda alkaline!) until no more oil distills over. Add strong alkali to the sulfite solution and continue distilling. Extract the distillation waters with ether and purify the crude pinocarvone by freezing, centrifuging, and distillation *in vacuo*.

Identification.—According to Schmidt,³ by the preparation of derivatives:

(1) The dibromide of *l*-pinocarvone melts at 73.5°–74°. It is obtained by adding 16 g. of bromine to a well-cooled solution of 15 g. of *l*-pinocarvone in chloroform and by removing the solvent through distillation.

(2) The semicarbazone of *l*-pinocarvone melts at 350°.

Properties.—Schmidt⁴ reported for a highly purified *l*-pinocarvone isolated from the last runs of Spanish eucalyptus oil, as described above:

f.p.	−1.8°	α_D	−68° 30′
d_{15}^{15}	0.9875	n_D^{20}	1.49498

Pinocarvone is very sensitive toward acids and is readily converted into carvone with accompanying ring opening. Pinocarvone possesses a peculiar odor. On exposure to air, this ketone resinifies easily.

In the light of Schmidt's recent discoveries, the earlier findings of the same author,⁵ of Wallach,⁶ Stallcup and Hawkins,⁷ and Joshel and Palkin,⁸ on "carvopinone" need to be modified, as Wallach's "carvopinone" is identical with pinocarvone.

Use.—Pinocarvone is not used in our industries.

¹ *Ber. Schimmel & Co.* (1941), 56. *Chem. Abstracts* **37** (1943), 4714.

² *Ber.* **77B** (1944), 167.

³ *Ibid.*

⁴ *Ibid.*

⁵ *Ber.* **63** (1930), 1131.

⁶ *Liebigs Ann.* **346** (1906), 231.

⁷ *J. Am. Chem. Soc.* **63** (1941), 3341.

⁸ *Ibid.* **64** (1942), 1008.

Carone

C₁₀H₁₆O

Mol. Weight 152.23

5-Ketocarane

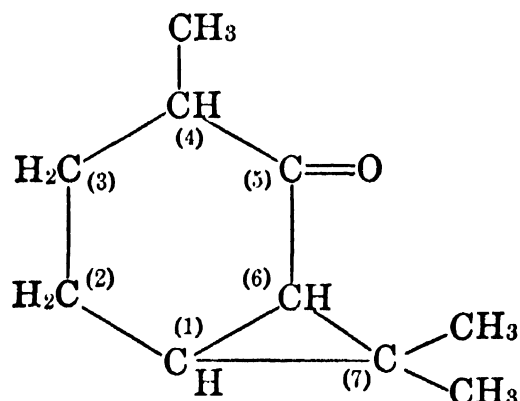

Occurrence.—Although this saturated bicyclic ketone has not yet been found in nature, its development in the course of several diagnostic reactions on terpenes from essential oils has been noted.

Identification.—Carone can be characterized:

(1) By the preparation of its semicarbazone, *d*- and *l*- form m. 167°–169°, *dl*- form m. 178°, according to Baeyer.¹

(2) By oxidation with a hot solution of potassium permanganate to caronic acid $C_7H_{10}O_4$, a saturated dibasic acid, the *cis*- modification melting at 175° , and the *d*-, *l*-, or *dl*-*trans*- modifications melting at 212° – 213° .² This latter form is converted to the *cis*- isomer by acetic anhydride. The anhydride of the *cis*- form melts at 54° – 56° .

Properties.—Carone is a colorless, mobile oil possessing a somewhat camphoraceous odor. The following properties have been reported by Baeyer,³ and Richter, Wolff and Presting:⁴

b.	210° ³ (with partial decomposition and isomerization to carvenone)	$[\alpha]_D$	$+173^\circ 48'$ and $-169^\circ 30'$ ³ (from caraway and spearmint oils, resp.)
b_{13}	98° ⁴	$[\alpha]_D$	$+134^\circ 0'$ ⁴ (from <i>l</i> -dihydrocarvone)
d_4^{17}	0.955 ⁴	n_D^{16}	1.478 ⁴

Baeyer⁵ found that carone reacts with bromine very slowly, not yielding any crystalline derivative. With hydrogen bromide, carone gives dihydrocarvone hydrobromide which can be characterized by the preparation of its oxime m. 118° – 120° .

Use.—Carone is not used in our industries.

¹ *Ber.* **28** (1895), 639.

² (a) Naves and Papazian, *Helv. Chim. Acta* **25** (1942), 984.

(b) Guha and Sankaran, *Current Science* **5** (1937), 388.

(c) Owen and Simonsen, *J. Chem. Soc.* (1933), 1223.

(d) Locquin, *Bull. soc. chim.* **15** (1914), 747.

³ *Ber.* **27** (1894), 1920; **28** (1895), 639.

⁴ *Ber.* **64** (1931), 877.

⁵ *Ber.* **27** (1894), 1920.

C. SESQUITERPENE KETONES

Atlantone

$C_{15}H_{22}O$

Mol. Weight 218.33

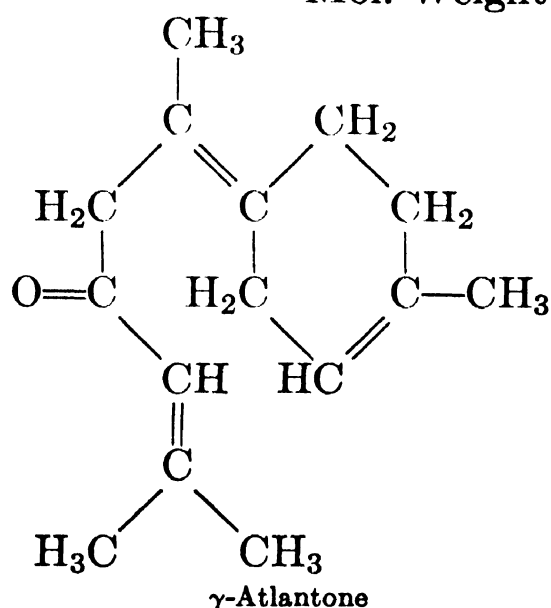
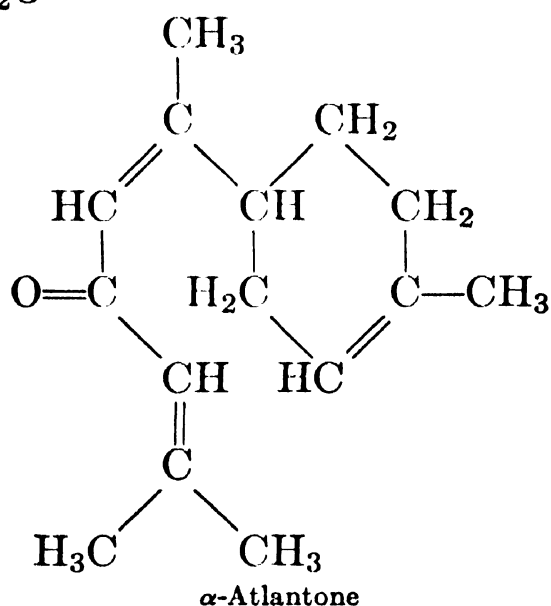

Occurrence.—According to Pfau,¹ and Pfau and Plattner,² the main constituent of Atlas cedarwood oil (*Cedrus atlantica* Manet.) and Himalaya cedar-

wood oil (*Cedrus deodora* Loud.) consists of a mixture of two monocyclic sesquiterpene ketones $C_{15}H_{22}O$ which, because of their analogy with α - and γ -bisabolene, were classified as α - and γ -atlantone (cf. Ruzicka and Capato ³). The two ketones are very sensitive and could not be separated from each other. Pfau and Plattner,⁴ after investigation, suggested the structural formulas pictured above.

Isolation.—Through the semicarbazones from the fraction b_1 120° – 121° of Atlas or Himalaya cedarwood oil.

Identification.—Both the α - and γ - isomers yield a semicarbazone without definitive characters. Upon decomposition of this derivative with potassium hydroxide at elevated temperature ($\approx 200^\circ$), according to Pfau and Plattner,⁵ a fraction b_{10} 137° – 140° is obtained which upon treatment with HCl gas in ether forms a trihydrochloride and has been identified as bisabolene-trihydrochloride m. 78.5° – 79° . Should it be necessary to identify specifically α - or γ -atlantone, this is best accomplished by the following scheme:

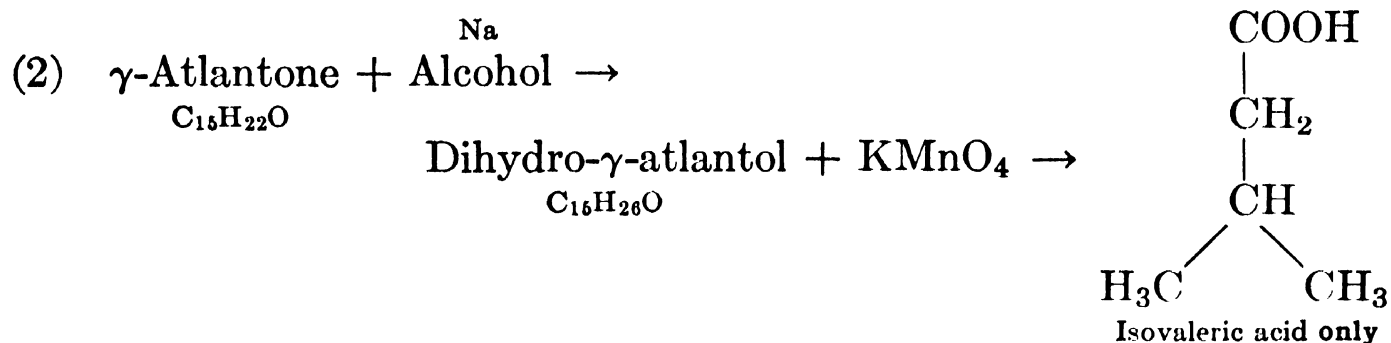
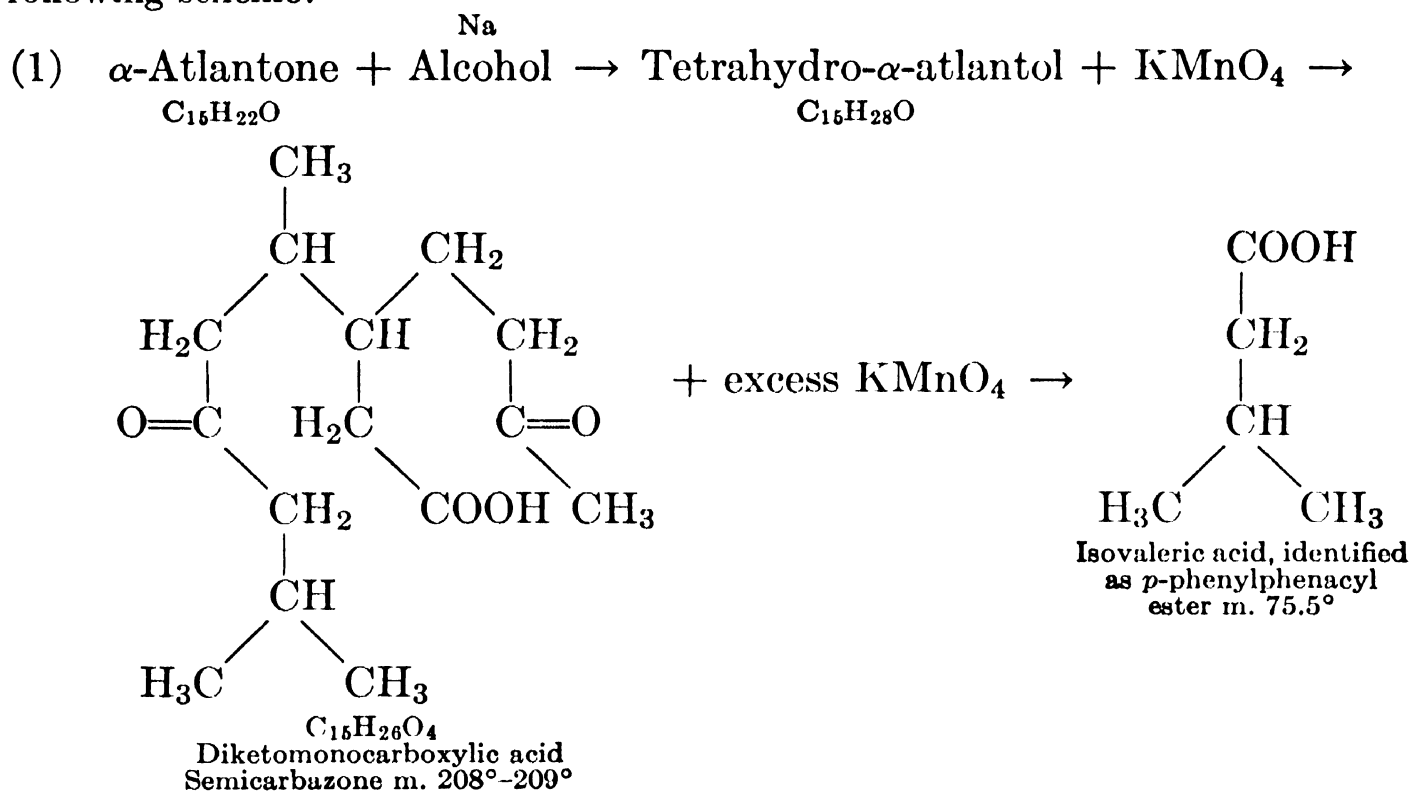

Properties.—The fraction rich in the atlantones had these properties:

b_1	121°–123°	α_D	+2° 48'
d_{20}	0.9562	n_D^{20}	1.5181

Use.—Atlantone, as such, is not used in our industries.

¹ *Helv. Chim. Acta* **15** (1932), 1481.

² *Ibid.* **17** (1934), 129.

³ *Ibid.* **8** (1925), 262.

⁴ *Ibid.* **17** (1934), 129.

⁵ *Ibid.* **17** (1934), 154.

$C_{15}H_{22}O$	Turmerone	Mol. Weight 218.33
	and	
$C_{15}H_{20}O$	<i>ar</i>-Turmerone	Mol. Weight 216.31
	"Tumerone"	

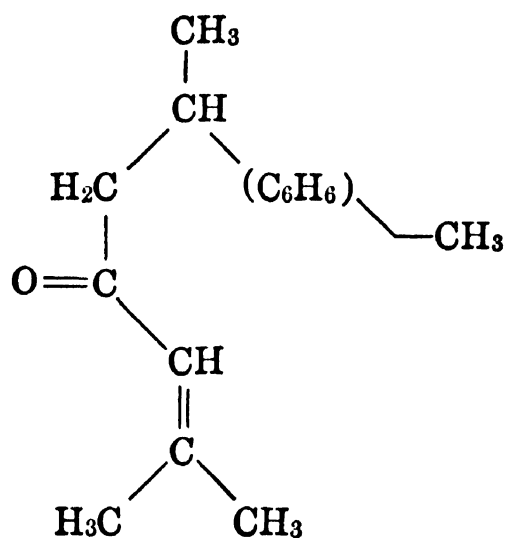

Turmerone

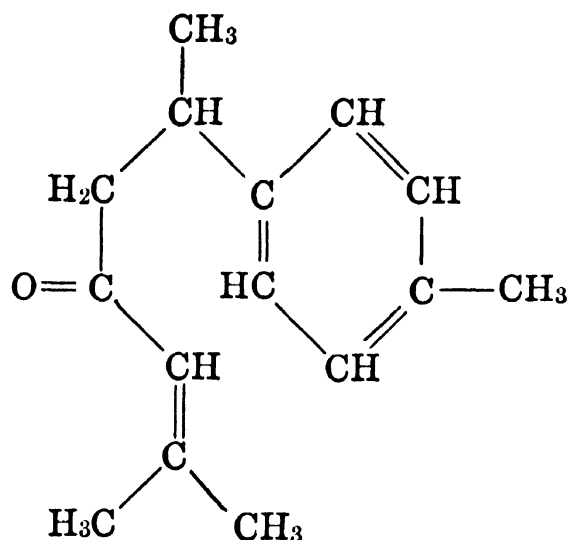
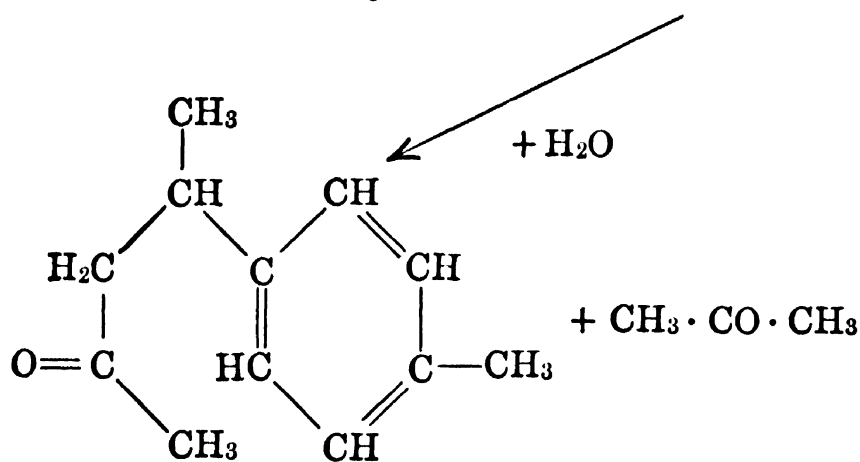
Dehydro-turmerone or *ar*-turmerone

Curcumone

Occurrence.—According to Pfau,¹ and Rupe, Clar, Pfau and Plattner,² the main fraction of the volatile oil derived from the rhizome of curcuma (*Curcuma longa* L.) consists of a monocyclic hydroaromatic ketone $C_{15}H_{22}O$, viz., turmerone, and an aromatic ketone $C_{15}H_{20}O$, viz., *ar*-turmerone or dehydro-turmerone. Hydrogenation and degradation products of these ketones along with a synthesis of *ar*-turmerone by Rupe and Gassmann³ have proved the validity of the structural formula suggested for *ar*-turmerone by Pfau and collaborators. These reactions also lend weight to the structure postulated for turmerone.

Isolation.—Turmerone has not been isolated in pure form. However, it appears to be present in the neutral fraction of curcuma oil b_{10} 155°–156°, and to be accompanied by *ar*-turmerone. Controlled dehydrogenation or oxidation of the fraction b_{10} 145°–165° with CrO_3 , separation of the cut b_{10} 160°–165°, subsequent treatment of this

fraction with dinitrophenylhydrazone, and regeneration of the ketone with hot alcoholic hydrochloric acid yield pure *d-ar*-turmerone, according to Rupe and Gassmann.⁴ Cleaving this *ar*-turmerone with sodium ethoxide and ozone, Rupe et al.⁵ obtained, respectively, *d*-curcumone and *d*-curcumatic acid m. 42°–43° C.

Identification.—As turmerone has not been obtained pure, identification is best carried on through the derived *d-ar*-turmerone. This latter product yields a dinitrophenylhydrazone m. 133°–134° and its dihydro *ar*-turmerone dinitrophenylhydrazone m. 121°–122° (Rupe and Gassmann⁶). Cleavage of the active *ar*-turmerone dinitrophenylhydrazone with concentrated hydrochloric acid gives *d*-curcumone, the dinitrophenylhydrazone of which melts at 89.5°.

Properties.—The following properties have been reported by Rupe and Gassmann⁷ and Rupe and others:⁸

<i>ar</i> -Turmerone		<i>d</i> -Curcumone	
b ₁₀	159°–160° ⁷	b ₁₀	115°–117° ⁸
d ₄ ²⁰	0.9634 ⁷	d ₂₀	0.9620 ⁸
[α] _D ²⁰	+82° 13' ⁷	α _D	+46° 32' ⁸
		n _D ²⁰	1.5046 ⁸

Use.—The turmerones, as such, are not used in our industries.

¹ *Helv. Chim. Acta* **15** (1932), 1482.

² *Ibid.* **17** (1934), 380.

³ *Ibid.* **19** (1936), 573.

⁴ *Ibid.*

⁵ *Ibid.* **7** (1924), 654; **17** (1934), 384.

⁶ *Ibid.* **19** (1936), 573, 581.

⁷ *Ibid.* Cf. Mukerji, *Science and Culture* **8** (1942), 40.

⁸ *Ibid.* **17** (1934), 385.

Eremophilone

C₁₅H₂₂O

Mol. Weight 218.33

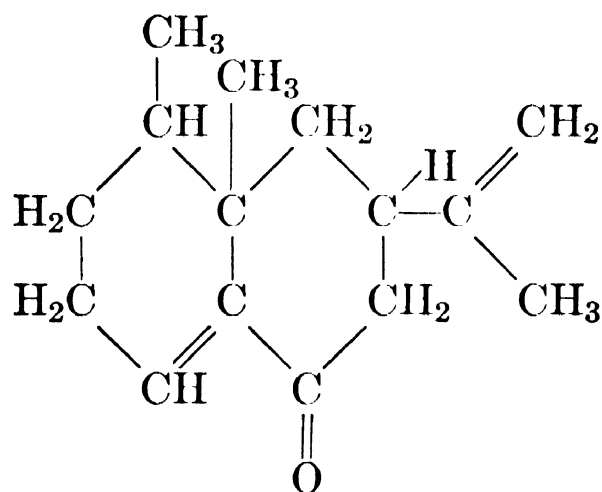

(According to Robinson)

Bradfield, Penfold and Simonsen¹ described three closely related ketones, viz., eremophilone C₁₅H₂₂O, hydroxyeremophilone C₁₅H₂₂O₂, and hydroxydihydroeremophilone C₁₅H₂₄O₂. The structural formula first suggested by these workers for eremophilone has subsequently been modified in the course

of investigations by Bradfield et al.,² and confirmatory evidence has been rendered for the suggestion by Robinson³ regarding the formula of this ketone. However, studies continue relative to the related hydroxyeremophilone (I) and hydroxydihydroeremophilone (II) for which Gillam and collaborators⁴ recently advanced the following formulas:

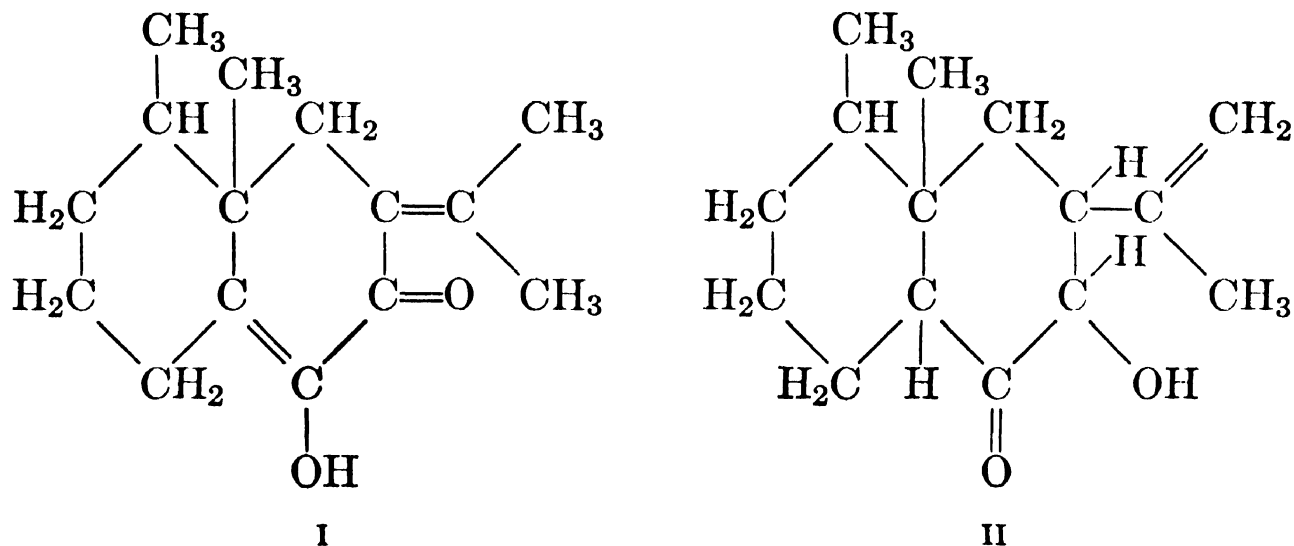

Occurrence.—The three above-named ketones occur in oil of *Eremophila mitchelli* Benth.

Isolation.—For details of best procedure in use at this writing see the papers by Bradfield, Hellström, Penfold and Simonsen,⁵ and Bradfield, Penfold and Simonsen.⁶

Identification.—Eremophilone forms a semicarbazone m. 202°–203° (with decomposition), and a tetrabromo derivative m. 116°.

Hydroxyeremophilone forms a benzoyl derivative m. 119°–120°.

Hydroxydihydroeremophilone yields a 2,4-dinitrophenylhydrazone m. 239°–241° (with decomposition), a dinitrobenzoate m. 145°–146°, and a diacetate m. 69°–70°.

Properties.—Bradfield, Penfold and Simonsen⁷ reported for these three sesquiterpene ketones the following properties:

Eremophilone

m.	41°–42°	[α] ₅₄₆₁	–207° (MeOH, c = 2.46)
b ₁₅	171°	n _D ²⁵	1.5182
d ₂₅ ²⁵	0.9994		

On reduction with sodium and alcohol, eremophilone yields dihydroeremophilol C₁₅H₂₆O, b₁₄ 168°–170°, which can be characterized by the preparation of a 3,5-dinitrobenzoate m. 119°–121°.

Hydroxyeremophilone

m.	66°–67°	[α] ₅₄₆₁	+153° (MeOH, c = 2.51)
b ₂₂	189°–190°	n _D ²⁵	1.5564
d ₂₅ ²⁵	1.0620		

On exposure to air, hydroxyeremophilone oxidizes with extreme rapidity.

Oxidation of hydroxyeremophilone with chromium dioxide in dilute acetic acid yields a phenol $C_{12}H_{18}O_3$, m. 193° – 194.5° , and a keto acid $C_{10}H_{16}O_3$, m. 105° – 107° .

Hydroxydihydroeremophilone

m. 102° – 103°
 $[\alpha]_{5461} +94^{\circ}$ (MeOH, $c = 2.02$)

Use.—These three sesquiterpene ketones are not used in our industry.

¹ *J. Chem. Soc.* (1932), 2744.

² *Ibid.* (1938), 767; (1939), 87; (1941), 60.

³ See Penfold and Simonsen, *J. Chem. Soc.* (1939), 87.

⁴ *J. Chem. Soc.* (1941), 60.

⁵ *Ibid.* (1938), 767.

⁶ *Ibid.* (1932), 2744.

⁷ *Ibid.*

Cyperone

$C_{15}H_{22}O$

Mol. Weight 218.33

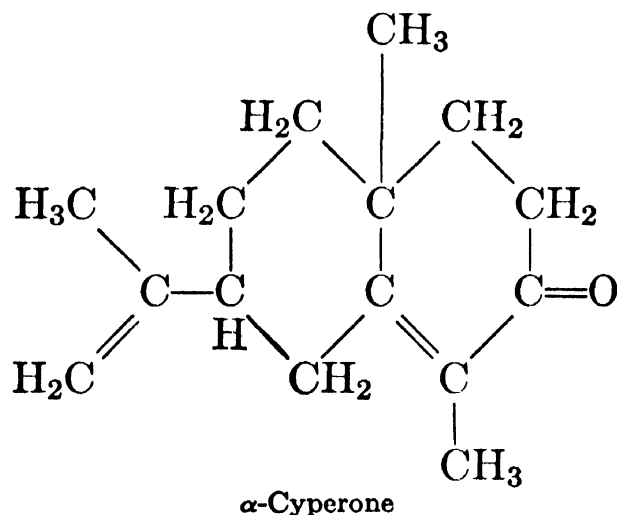

This structural formula of cyperone, a sesquiterpene ketone, was suggested by Bradfield, Pritchard and Simonsen.¹ Since the semicarbazones of α - and β -cyperone give the same product of degradation, α - and β -cyperone are apparently stereoisomers, differing in the spatial placement of the methyl and the isopropenyl groups.

Occurrence.—According to Hegde and Rao,² and Bradfield, Hegde, Rao, Simonsen and Gillam,³ α -cyperone is the main constituent of oil of *Cyperus rotundus* Linn. which contains 33–54 per cent of ketones.

Isolation.— α -Cyperone can be isolated from volatile oils through its semicarbazone.

Identification.—The cyperones may be characterized by the preparation of several derivatives:

Derivative	Isomers, m.	
	α -	β -
Semicarbazone	216°	207°
Oxime	150.5°	138°
2,4-Dinitrophenylhydrazone	209° – 210°	218° – 219° (decomp.)
		(Red crystals show a bronze reflex)
Nitroguanylhudrazone	203° – 204°	197°

Properties.—The above-named authors reported the following properties for α -cyperone:

b_{20}	177°	$[\alpha]_{5461}$	$+138^\circ$
d_{25}^{25}	0.9946	$[\alpha]_{5780}$	$+118^\circ 36'$
		n_D^{25}	1.5283

On treatment with aqueous oxalic acid or methyl alcoholic potassium hydroxide, α -cyperone is isomerized to β -cyperone for which these properties have been reported:

b_{16}	$175^\circ-176^\circ$	$[\alpha]_{5461}$	$+239^\circ$
d_{25}^{25}	0.9945	n_D^{20}	1.5414

α -Cyperone and the stereoisomeric β -cyperone have been prepared synthetically by Adamson, McQuillin, Robinson and Simonsen⁴ from dihydrocarvone. The principal physicochemical properties of the natural and the synthetic α - and β -cyperone are very similar, but certain differences in the optical and crystallographic data of the respective oximes and semicarbazones shed some doubt regarding the absolute identity of the synthetic and the natural cyperones.

Use.—Cyperone, as such, is not used in our industry, although the tubers of *Cyperus rotundus* Linn. from which it is derived have found favor in oriental medicine and perfumery.

¹ *J. Chem. Soc.* (1937), 760.

³ *J. Chem. Soc.* (1936), 667.

² *J. Soc. Chem. Ind.* **54** (1935), 388 T.

⁴ *Ibid.* (1937), 1576.

SUGGESTED ADDITIONAL LITERATURE

Conrado F. Asenjo, "Some of the Constituents of the Tuber 'Coqui' (*Cyperus rotundus* L.). The Volatile Oil," *J. Am. Pharm. Assoc.* **30** (1941), 628. *Chem. Abstracts* **36** (1942), 2172.

Vetivone

(Vetiverone)

$C_{15}H_{22}O$

Mol. Weight 218.33

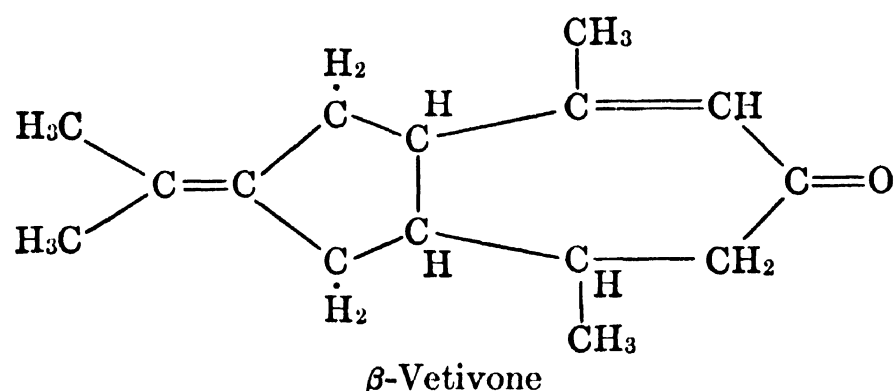

The structural formula of β -vetivone as pictured above was established by Pfau and Plattner.¹ Naves and Perrottet² expressed the opinion that α -

and β -vetivones are stereoisomers, both modifications possessing the same plane projection formula. The odor of vetiver oil is due primarily to the ketonic sesquiterpenes $C_{15}H_{22}O$ (bicyclic and α -ethylenic), of which only α -vetivone and β -vetivone have been isolated so far.

Occurrence.—According to an old German Patent,³ oil of vetiver contains a mixture of isomeric ketones $C_{13}H_{22}O$ called "vetiverone" which can be isolated through their semicarbazones. More recently Pfau and Plattner,⁴ and Sabetay and Trabaud⁵ almost simultaneously but independently found that the ketones occurring in Java and Réunion vetiver oil possess the empirical molecular formula $C_{15}H_{22}O$ and not $C_{13}H_{22}O$, as claimed in the above-mentioned German patent. Sabetay and Trabaud retained the designation vetiverone, while Pfau and Plattner, and Naves and Perrottet gave preference to the term "vetivone." By all evidence, vetivone and vetiverone, as considered in recent work, are identical. Isolating the ketones by a modified hydroxylamine method, Pfau and Plattner examined eighty-nine Java and Réunion vetiver oils and came to the conclusion that these oils contained from 7.8 to 35.1 per cent, in most cases from 15 to 27 per cent, of ketones. These analytical figures are considerably higher than the actual yield obtained when isolating the ketones from vetiver oil by various methods. By oximation, Sabetay and Trabaud⁶ arrived at a ketone content ranging from 12 to 13 per cent.

Isolation.—Sabetay and Trabaud isolated the ketones from vetiver oil with the "P" reagent (acetyl hydrazine *pyridinium* chloride) of Girard and Sandulesco.⁷ Treating 500 g. of genuine Réunion vetiver oil in 1.5 liters of alcohol and 75 g. of acetic acid with 75 g. of the Girard and Sandulesco reagent "P," Sabetay and Trabaud⁸ thus obtained 11.6% of crude ketones containing 84.8% of vetiverone as determined by oximation in the cold and in the presence of calcium carbonate. Distillation of this ketone fraction *in vacuo* yielded a main fraction b_{14} 138° – 148° which gave a semicarbazone m. 210° . On decomposition of the semicarbazone with dilute sulfuric acid at elevated temperature, a main fraction b_{12} 142° – 150° , containing 89.5% vetiverone, was obtained. Correspondingly, Java vetiver oil on treatment with the reagent of Girard and Sandulesco, yielded about 13% of a ketone fraction which gave a main fraction b_{20} 150° – 155° possessing these properties: d_{15} 1.001, α $+80^{\circ} 40'$, n_D^{20} 1.5355.

Pfau and Plattner⁹ found this reagent of Girard and Sandulesco unsatisfactory because of difficulty in regeneration and resorted to the semicarbazone for separation of this ketone from an enriched fraction of vetiver oil. A ketone fraction b_4 152° – 160° containing 81.5% vetivone gave a crude semicarbazone mixture which on fractional crystallization by use of a variety of solvents yielded the semicarbazone of β -vetivone m. 228° – 229° , and of α -vetivone m. 210° – 212° (with decomposition). According to Pfau and Plattner,¹⁰ the ketone fraction of vetiver oil varies according to the origin of the oil from about 20 to about 90%, and the yield of β -vetivone from 2% to 49%. Treatment of the semicarbazone of β -vetivone with phthalic anhydride gave β -vetivone, while the corresponding treatment of the semicarbazone of α -vetivone yielded α -vetivone. Crystallization of β -vetivone oil from petroleum ether gave pure β -vetivone m. 44° – 44.5° .

Identification.—The vetivones can be characterized by the preparation of several derivatives:

(1) The semicarbazones:

According to Naves and Perrottet,¹¹ the semicarbazone of α -vetivone, on recrystallization from acetic acid, deposits first, and on recrystallization from absolute alcohol gives a pale yellow crystalline powder m. 222° – 223° , $[\alpha]_{\text{D}} +334^{\circ} 12'$ ($c = 4\%$ in acetic acid).

Recrystallization of the semicarbazone of β -vetivone from dry pyridine yields nacreous leaflets m. 228° – 229° , $[\alpha]_{\text{D}} -71^{\circ} 6'$ ($c = 4\%$ in acetic acid).

According to Pfau and Plattner,¹² the semicarbazone of β -vetivone melts at 228° – 229° , $[\alpha]_{\text{D}}^{20} -71^{\circ} 0'$ in glacial acetic acid, whereas that of α -vetivone melts at 210° – 212° (with decomposition), $[\alpha]_{\text{D}}^{20} +316^{\circ} 0'$ in glacial acetic acid.

(2) The dinitrophenylhydrazones:

Naves and Perrottet¹³ prepared the 2,4-dinitrophenylhydrazone of α -vetivone m. 149° , and that of β -vetivone m. 190.5° – 191° .

Properties.—The mixture of vetiver ketones, isolated by Sabetay and Traubaud¹⁴ from Bourbon (Réunion) vetiver oil and purified through the semicarbazone m. 210° , had these properties:

b_{12}	142° – 150°	α_{D}	$+74^{\circ} 0'$
d_{15}	1.002	n_{D}^{20}	1.5252

Similarly, Java vetiver oil gave a vetiverone (semicarbazone m. 210°) of these properties:

b_{20}	150° – 155°	α_{D}	$+80^{\circ} 40'$
d_{15}	1.001	n_{D}^{20}	1.5355

Naves and Perrottet¹⁵ reported the following properties for α - and β -vetivone, after reconversion from the semicarbazone, distillation in an atmosphere of carbon dioxide, washing, rectification, and recrystallization from pentane:

<i>α-Vetivone</i>			
m.	51° – 51.5°	d_4^{20}	1.0035 (superfusion)
b_2	144° – 144.5°	$[\alpha]_{\text{D}}$	$+238^{\circ} 15'$ ($c = 6.934$ in alc.)
$b_{0.85}$	126° – 127°	n_{D}^{20}	1.5370 (superfusion)

α -Vetivone has a sweet, agreeable, powerful odor, characteristic of vetiver oil.

<i>β-Vetivone</i>			
m.	44° – 44.5°	$[\alpha]_{\text{D}}$	$-38^{\circ} 55'$ ($c = 10.62$ in alc.)
b_2	141° – 142°	n_{D}^{45}	1.5216
$b_{1.15}$	130° – 132°	n_{D}^{20}	1.5309
d_4^{45}	0.9804 (superfusion)		
d_4^{20}	1.0001 (superfusion)		

Certain of these data are comparable to those obtained earlier by Pfau and Plattner.¹⁶

The odor of β -vetivone is relatively faint, reminiscent of styrax.

When treating α -vetivone with selenium, Naves and Perrottet¹⁷ obtained eudalinol m. 85° – 85.5° , phenylurethane m. 135° . Treatment of the neutral fraction of the distillate (reaction product with selenium) with phosphoric acid produced 2.3 per cent of vetivazulene, picrate m. 122° – 122.5° .

β -Vetivone does not form a bisulfite compound. Dehydrogenating β -vetivone with palladium, sulfur and selenium, Pfau and Plattner¹⁸ obtained mainly vetivazulene, furthermore, vetivalene (1,5-dimethyl-3-isopropyl-naphthalene), eudalene, a C_{14} naphthol and azulene.

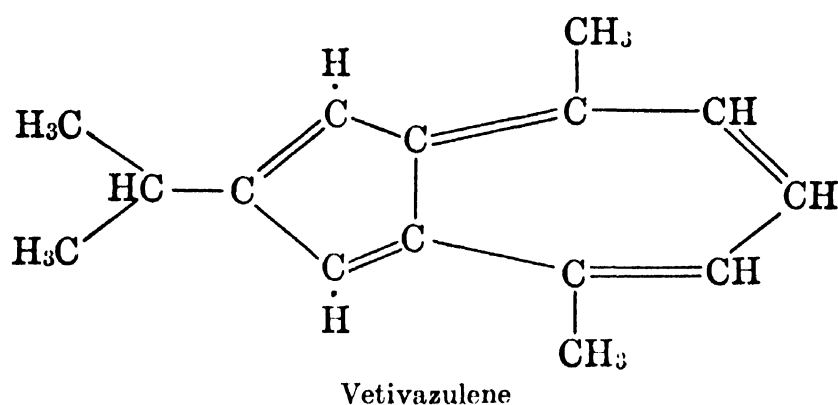

Use.—Nothing is known in literature about the use of the vetivones, as such, in perfumes and cosmetics, but it seems quite possible that some of the specialties offered by certain essential oil houses are based upon vetivones or ketone fractions of vetiver oil. Since they possess the typical odor of vetiver oil in more concentrated and lasting form, these ketones may form valuable adjuncts in the compounding of fine and modern perfumes, especially those of oriental character.

¹ *Helv. Chim. Acta* **23** (1940), 768.

² *Ibid.* **24** (1941), 3.

³ German Patent 142,415, Feb. 2, 1902.

⁴ *Helv. Chim. Acta* **22** (1939), 640.

⁵ *Bull. soc. chim.* [5], **6** (1939), 740.

⁶ *Ibid.*

⁷ *Helv. Chim. Acta* **19** (1936), 1095.

⁸ *Bull. soc. chim.* [5], **6** (1939), 740.

⁹ *Helv. Chim. Acta* **22** (1939), 648.

¹⁰ *Ibid.*

¹¹ *Helv. Chim. Acta* **24** (1941), 19.

¹² *Ibid.* **22** (1939), 640.

¹³ *Ibid.* **24** (1941), 19.

¹⁴ *Bull. soc. chim.* [5], **6** (1939), 740.

¹⁵ *Helv. Chim. Acta* **24** (1941), 20.

¹⁶ *Ibid.* **22** (1939), 640.

¹⁷ *Ibid.* **24** (1941), 21.

¹⁸ *Ibid.* **23** (1940), 768.

D. THE IONONES

 α -Ionone $C_{13}H_{20}O$

Mol. Weight 192.29

α -Cyclocitrylideneacetone. 4-[2,6,6-Trimethyl-2-cyclohexen-1-yl]-3-buten-2-one

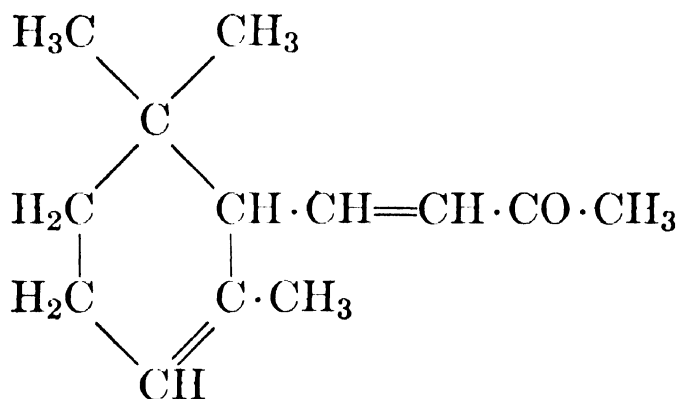
 β -Ionone

β -Cyclocitrylideneacetone. 4-[2,6,6-Trimethyl-1-cyclohexen-1-yl]-3-buten-2-one

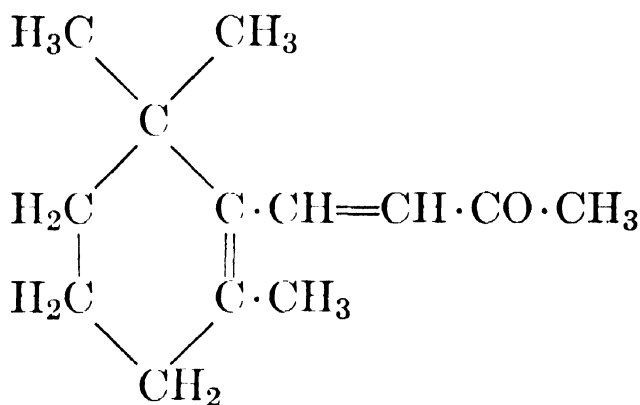

Occurrence.—Penfold¹ first observed β -ionone in the flower oil of *Boronia megastigma* Nees. When other workers expressed doubts about the purity of the flower oil investigated by Penfold, Naves and Parry² prepared an authentic product and identified in it β -ionone, *d*- α -ionone, and *dl*- α -ionone. Tischer³ reported the identification of ionone in violet moss (*Trentepolia jolithus* [L.] Wallr.) whose gold-yellow color is due to carotene. Tischer concluded that the typical violet odor (ionone) of this moss originates in the living plant by the decomposition of carotene, probably under the influence of enzymes.

In view of their great commercial importance, a short discussion of the ionones and their synthesis is advisable; for details the reader is referred to the ample patent literature and to books on synthetic aromatics.

The ionones are prepared through condensation of the olefinic terpene aldehyde citral with acetone, by the action of alkaline reagents, whereby ψ -

ionone, an olefinic ketone $C_{13}H_{20}O$, is obtained as intermediate product of the reaction

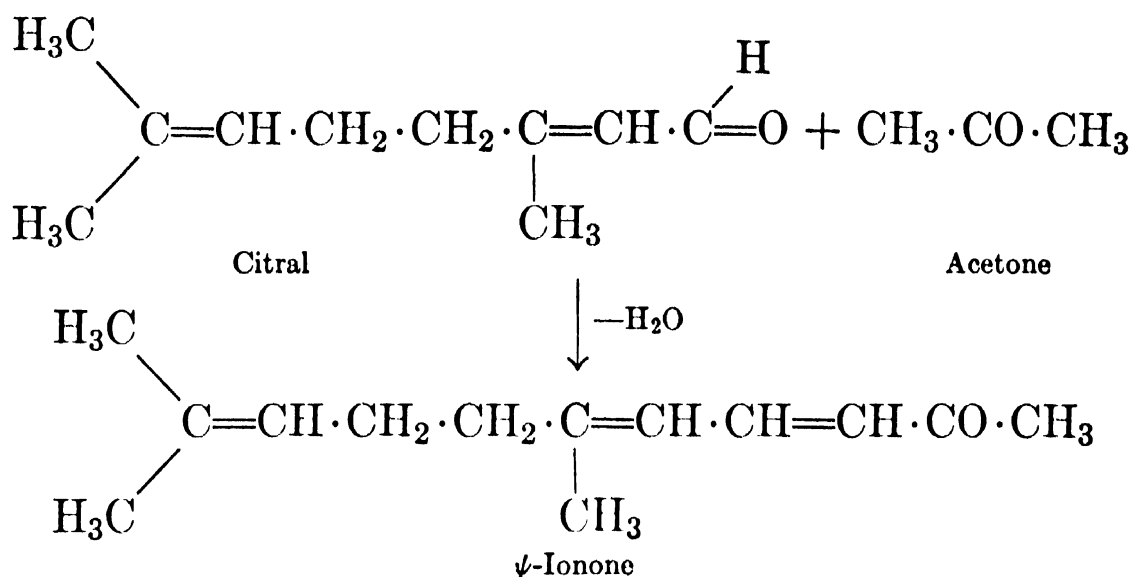

The aliphatic ketone ψ -ionone is subsequently cyclicized by a variety of methods ⁴ (with reagents such as sodium bisulfate, concentrated sulfuric or phosphoric acid, dilute nitric or formic acid, dilute mineral acids, sodium acetate, etc.) to ionone. In all cases a mixture of isomeric α - and β -ionones will result from the cyclization, their ratio depending upon the process employed. The action of sulfuric acid, for example, yields mainly β -ionone, while with phosphoric or formic acid chiefly α -ionone is obtained.

ψ -Ionone

(pseudo-Ionone)

Tiemann ⁵ found that this olefinic ketone does not react with sodium bisulfite at room temperature but on prolonged boiling with bisulfite solution ψ -ionone forms a water soluble hydrosulfonic acid compound. By extracting the hydrosulfonic acid compound repeatedly with ether, products of resinification and other impurities can be removed. The parent ketone is regenerated by decomposition of the hydrosulfonic acid compound with alkali. Steam distillation yields ψ -ionone in pure form.

ψ -Ionone can be identified by the preparation of its *p*-bromophenylhydrazone m. 102° – 104° , and 2,4-dinitrophenylhydrazone m. 143° . Pure ψ -ionone is a yellowish, somewhat viscid oil with a peculiar odor. It has these properties:

b_{12}	143° – 145°
d_{20}	0.8984
n_D	1.53346

α -Ionone

Identification.— α -Ionone may be identified:

(1) By the preparation of its oxime m. 89° – 90° , which crystallizes from a petroleum ether solution at low temperature.

(2) By its semicarbazone I m. 107° – 108° , II 137° – 138° ; 142° – 143° corr. (Naves and Bachmann ⁶).

(3) By its thiosemicarbazone m. 121° .

(4) By its *p*-bromophenylhydrazone m. 142° – 143° , prepared in glacial acetic acid solution and recrystallized from dilute methyl alcohol or ligroine. It is the compound best suited for the identification of α -ionone.

The *p*-nitrophenylhydrazone m. 113° , 4-phenylsemicarbazone m. 186.5° – 187° corr. (see Naves and Bachmann), 2,4-dinitrophenylhydrazone (see Brady,⁷ also section on "Properties"), and 3-benzohydrazone m. 149.5° – 150.5° (Naves and Bachmann) have all been found suitable as derivatives for this ketone.

Properties.— α -Ionone, especially in dilution, possesses a typical violet-like odor reminiscent also of orris root. According to Auwers and Eisenlohr,⁸ pure α -ionone has these properties:

Regenerated from its oxime:

b_{11}	123° – 124°
d_{20}	0.932
n_D^{20}	1.4980

Regenerated from its bisulfite compound:

b_{12}	127.6°
d_4^{20}	0.9287
n_D^{17}	1.5002

Using a similar method of recovery Naves and Bachmann⁹ recently prepared a highly purified sample whose properties correspond very closely to those described by the earlier workers.

Tiemann¹⁰ reported for α -ionone:

b_{11}	123° – 124°
d_{20}	0.932
n_D	1.4980

Chuit¹¹ recorded:

b_{12}	127.6°
d_{15}	0.9338
$n_D^{17.2}$	1.50001

Recently Sobotka et al.¹² specifically resolved a *dl*- isomer (n_D^{23} 1.4995) by means of *l*-menthydrazide: *l*- α -ionone *l*-menthydrazide $[\alpha]_D^{22}$ -320° 0' in ethyl

alcohol, m. 185°; *d*- α -ionone *l*-menthydrazide $[\alpha]_D^{22} +230^\circ 0'$ in ethyl alcohol, m. 176°. By decomposition of these *l*- and *d*-menthydrazides of α -ionone, they obtained the optically active α -ionones and the corresponding derived phenyl hydrazones with these properties:

<i>l</i> - α -Ionone		<i>d</i> - α -Ionone	
$[\alpha]_D^{27}$	$-406^\circ 0'$	$[\alpha]_D^{23}$	$+347^\circ 0'$
n_D^{25}	1.500	n_D^{22}	1.5021
2,4-dinitrophenylhydrazone		2,4-dinitrophenylhydrazone	
m. 133°		m. 129°	
<i>p</i> -chlorobenzoylhydrazone		<i>p</i> -chlorobenzoylhydrazone	
m. 200°–201°		m. 196°–198°	

The 2,4-dinitrophenylhydrazone obtained from the *dl*- α -ionone melted at 143°, and the *p*-chlorobenzoylhydrazone at 214°.

β -Ionone

Identification.— β -Ionone may be identified, according to Tiemann: ¹³

(1) By the preparation of its semicarbazone m. 148°–149°.

(2) By its thiosemicarbazone m. 158°.

(3) By its hydrazone m. 104°–105°.

(4) By its *p*-bromophenylhydrazone m. 115°–116°.

(5) By its *p*-nitrophenylhydrazone m. 173°.

Allen and Gates ¹⁴ reacted β -ionone with 1-methyl-3-carbohydrazicopyridinium *p*-toluene sulfonate, obtaining a derivative melting at 147°. Since this reagent does not react with α -ionone, it offers itself as a possible compound to differentiate and to separate these isomers in a commercial product.

Wilson, ¹⁵ as a result of a collaborative study, selected the optical crystallographic properties of *m*-nitrobenzhydrazone as a most satisfactory method of identifying β -ionone in quantities as small as 10 mg.

Müller ¹⁶ employed the new "EM" reagent to identify colorimetrically and distinguish between the α - and β - isomers.

The 4-phenylsemicarbazone is reported as m. 157.5°–158°, the dinitro-2,4-phenylhydrazone m. 128.5°–129°, the *l*-menthylhydrazide m. 178°, $[\alpha]_D -35^\circ 0'$.

The oxime of β -ionone is liquid.

Properties.— β -Ionone possesses an odor somewhat stronger than α -ionone with a faint leather-like "by-note." According to Auwers and Eisenlohr, ¹⁷ pure β -ionone has these properties:

Regenerated from its semicarbazone:

b_{18}	140°
d_{17}	0.946
n_D^{17}	1.521

Regenerated from its sodium bisulfite compound:

b_{16}	140.4°
d_{15}	0.9488
$n_D^{16.3}$	1.52072

Tiemann ¹⁸ reported for pure β -ionone:

b_{10}	127°–128.5°
d_{17}	0.946
n_D^{17}	1.521

Chuit ¹⁹ recorded:

b_{12}	134.6°
d_{15}	0.9488
$n_D^{17.5}$	1.52008

The Separation of the Ionones

As stated, the preparation of ionones from citral via ψ -ionone always results in a mixture of α - and β -ionone, their ratio depending upon the process employed. Gildemeister and Hoffmann ²⁰ suggested these average properties of α - and β -ionone mixtures:

b_{10}	126°–128°	d_{15}^{15}	0.9350–0.9403
b_{4-5}	104°–109°	n_D^{20}	1.50335–1.50510

The crude ionones can be purified by preparing the water soluble bisulfite compound with a boiling solution of sodium bisulfite (see " ψ -Ionone"). Extraction with ether eliminates the neutral products. The bisulfite compound is finally decomposed with alkali and steam distilled. Treatment of the ionones with an alcoholic solution of potassium hydroxide removes unchanged ψ -ionone.

α - and β -Ionone can be separated by several methods:

(1) Through the difference in the properties of their bisulfite derivatives, according to German Patent No. 106,512 (Haarmann and Reimer). β -Ionone is regenerated from the bisulfite compound, and separated by mere steam distillation, whereas α -ionone can be regenerated from the residue only after treatment with alkali.

(2) According to British Patent No. 18,333 (Chuit and Naef), the sodium bisulfite compound of α -ionone $C_{13}H_{21}OSO_3Na \cdot 3H_2O$, is precipitated by saturation of the solution with sodium chloride whereby the β -ionone compound $C_{13}H_{21}OSO_3Na \cdot 2H_2O$, remains in solution. The two bisulfite compounds are then separated, each is decomposed with alkali, and α - and β -ionone isolated by steam distillation.

(3) By the use of formaldehyde, acetaldehyde, or acetone as agents for decomposition of the bisulfite compound, according to British Patent No. 472,545, September 23, 1937. Temperature is the critical factor.

(4) According to Tiemann,²¹ through the different solubilities of their semicarbazones. The β -ionone derivative is very sparingly soluble and thereby can be separated in pure form while the crude α -ionone semicarbazone remains in the mother liquor. By hydrolysis of the α -ionone compound, the parent ketone is regenerated and converted into α -ionone oxime which crystallizes at a low temperature. The β -ionone oxime is an oil.

A similar procedure has recently been outlined by Young, Cristol, Andrews and Lindenbaum.²² These authors recommend decomposition of the highly purified semicarbazone with cold sulfuric acid, to obtain a very pure β -isomer.

By the action of concentrated sulfuric acid, α -ionone is inverted to β -ionone; vice versa, by the action of alkali in alcoholic solution, β -ionone may be inverted to α -ionone, but not as readily.

In order to test a commercial ionone preparation for its actual content of ionone, it is necessary to remove first any by-products which may have originated during the manufacturing process. For this purpose, Gildemeister and Hoffmann²³ suggested boiling (reflux condenser) the oil in question for ten to fifteen hours with three times its weight of sodium bisulfite solution in which the free sulfurous acid has been neutralized with dilute soda solution. The duration of the refluxing depends on the reaction of the ionone with the bisulfite. In order to remove the neutral substances which do not react with bisulfite, the solution is first diluted with water and four times extracted with ether. If the ionone is comparatively pure, the addition of water will cause but a slight turbidity; if impure, separation of oil will take place. In case the odor of the separated oil indicates the presence of ionone, repeated treatment with bisulfite is necessary. The difference between the amount of oil originally used and the amount extracted is computed as ionone. Some idea as to the relative proportions of α - and β -ionone in a mixture of ionones can be obtained from the physical properties of the ionone mixture, after regeneration from the bisulfite compound, and steam distillation. Naves and Bachmann²⁴ have found data on the dispersion of optical refractivity particularly useful in this connection.

Use.—The ionones (but not ψ -ionone) belong to some of the most important synthetic aromatics used most widely in perfumes, cosmetics, and the scenting of soaps. They serve in floral odors as well as in compositions of fancy character.

¹ *J. Roy. Soc. W. Australia* **14** (1927–28), 1.

² *Helv. Chim. Acta* **30**, I (1947), 419. According to a recent publication of Naves (*ibid.*, 956), small quantities of β -ionone occur in the press residue of raspberry. Naves attributes this to degradation of carotene or a similar compound.

- ³ *Z. physiol. Chem.* **243** (1936), 103. *Chem. Abstracts* **31** (1937), 130.
⁴ For laboratory methods, see Hibbert and Cannon, *J. Am. Chem. Soc.* **46** (1924), 127.
⁵ *Ber.* **31** (1898), 842, 846.
⁶ *Helv. Chim. Acta* **26** (1943), 2151; **27** (1944), 645.
⁷ *J. Chem. Soc.* (1931), 756.
⁸ *J. prakt. Chem.* II, **82** (1910), 126.
⁹ *Helv. Chim. Acta* **26** (1943), 2151.
¹⁰ *Ber.* **31** (1898), 876.
¹¹ *Rev. gen. chim.* **6** (1903), 432.
¹² *J. Am. Chem. Soc.* **65** (1943), 2061.
¹³ *Ber.* **31** (1898), 871, 879, 1736. Cf. Chuit, *Chem. Zentr.* I (1904), 281.
¹⁴ *J. Org. Chem.* **6** (1941), 596.
¹⁵ *J. Assocn. Off. Agr. Chem.* **22** (1939), 378.
¹⁶ *Deut. Parfümerieztg.* **26** (1940), 239; **27** (1941), 190. *Chem. Zentr.* I (1941), 1892; I (1942), 1442. Cf. Naves, *Helv. Chim. Acta* **30**, I (1947), 420.
¹⁷ *J. prakt. Chem.* II, **84** (1911), 68.
¹⁸ *Ber.* **31** (1898), 871, 879.
¹⁹ *Rev. gen. chim.* **6** (1903), 432.
²⁰ "Die Ätherischen Öle," 3d Ed., Vol. I, 589.
²¹ *Ber.* **31** (1898), 874, 1737.
²² *J. Am. Chem. Soc.* **66** (1944), 855.
²³ "Die Ätherischen Öle," 3d Ed., Vol. I, 591.
²⁴ *Helv. Chim. Acta* **26** (1943), 2151.

SUGGESTED ADDITIONAL LITERATURE

Hans Köster, "Constitution of Methyl Ionones," *J. prakt. Chem.* **143** (1935), 249. *Chem. Abstracts* **29** (1935), 7295.

Dissertation by Domenick Papa, "The Methyl Ionones: A Proof of Structure," Columbia University (1937).

Hans Köster (Haarmann & Reimer, Holzminden), "The Double Bond of the Ionone Ring. Perfumes of the Ionone Group," *Ber.* **77B** (1944), 553. *Chem. Abstracts* **40** (1946), 5401.

Y. R. Naves, "Sur de Soi-disant Formylations d'Ionones," *Helv. Chim. Acta* **29**, I (1946), 12.

E. Earl Royals (Georgia School of Technol., Atlanta), "Cyclization of Pseudo Ionone by Acidic Reagents," *Ind. Eng. Chem.* **38** (1946), 546. *Chem. Abstracts* **40** (1946), 4023.

Y. R. Naves, "Sur le Dédoublément de la *d,l*- α -Ionone," *Helv. Chim. Acta* **30** (1947), 769.

Y. R. Naves, O. Schwarzkopf and A. D. Lewis, "Sur les Époxydes des Ionones," *Helv. Chim. Acta* **30** (1947), 880.

Y. R. Naves, A. V. Grampoloff and P. Bachmann, "Études dans les Séries des Méthyl-3-linalols, des Méthyl-3-citrals et des Méthyl-6-ionones," *Helv. Chim. Acta* **30** (1947), 1599.

M. Winter, H. Schinz and M. Stoll, "Synthèse de la 4-Méthyl-ionone," *Helv. Chim. Acta* **30** (1947), 2213.

A. Rouvé and M. Stoll, "Synthèse de la 5-Méthyl-ionone," *Helv. Chim. Acta* **30** (1947), 2216.

Hans Köster, "Perfumes of the Ionone Group. Condensation of Citral with Ketones," *Chem. Ber.* **80** (1947), 248. *Chem. Abstracts* **42** (1948), 4956.

Dihydro- γ -Ionone $C_{13}H_{22}O$

Mol. Weight 194.31 .

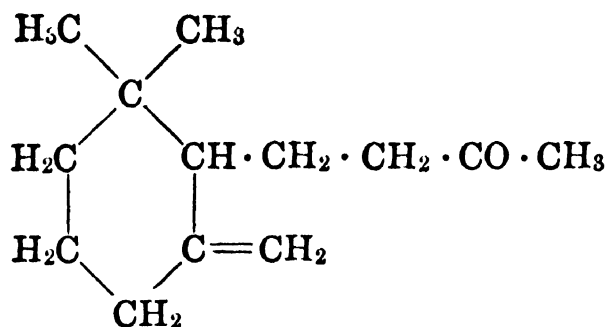

Occurrence.—According to Ruzicka, Seidel and Pfeiffer¹ *d*-dihydro- γ -ionone is one of the volatile constituents of ambergris. (The chief constituent of ambergris is ambreine, a solid nonvolatile triterpene alcohol.²)

Isolation.—The volatile constituents of the ambergris are isolated by steam distillation of the mother liquor of the ambreine. The neutral portions of the steam distillate are then distilled *in vacuo*, separating the middle fractions b_{10} 60° to $b_{0.1}$ 130° which contain the oxygenated constituents. Depending upon the quality of the ambergris, these middle fractions amount to 1.5–3% of the raw material used. Treatment of the middle fractions with Girard's reagent T and regeneration yield a mixture of ketones, amounting to one-fifth of the above mentioned middle fractions. The regenerated ketones are finally submitted to fractional distillation; b_{10} 114°–116°.

Identification.—By preparation of the semicarbazone m. 189°–190°.

Properties.—Regenerating the ketone from its semicarbazone, Ruzicka et al.³ found these properties for *d*-dihydro- γ -ionone:

b_{10}	116°–118°	α_D	+1° 30'
d_4^{22}	0.9347	n_D^{22}	1.4789

Dihydro- γ -ionone possesses the typical odor of ambergris, whereas the odor of dihydro- α -ionone and dihydro- β -ionone resembles that of cedarwood.

Dihydro- γ -ionone has been synthesized by Ruzicka, Büchi and Jeger.⁴

Use.—Nothing is noted as yet in literature regarding the availability of synthetic dihydro- γ -ionone.

¹ *Helv. Chim. Acta* **31** (1948), 827.

² Cf. Ruzicka and Lardon, *ibid.* **29** (1946), 912. Ruzicka, Dürst and Jeger, *ibid.* **30** (1947), 353. Jeger, Dürst and Ruzicka, *ibid.* **30** (1947), 1859.

³ *Ibid.* **31** (1948), 827.

⁴ *Ibid.*, 293.

E. THE IRONES

 $C_{14}H_{22}O$

Mol. Weight 206.32

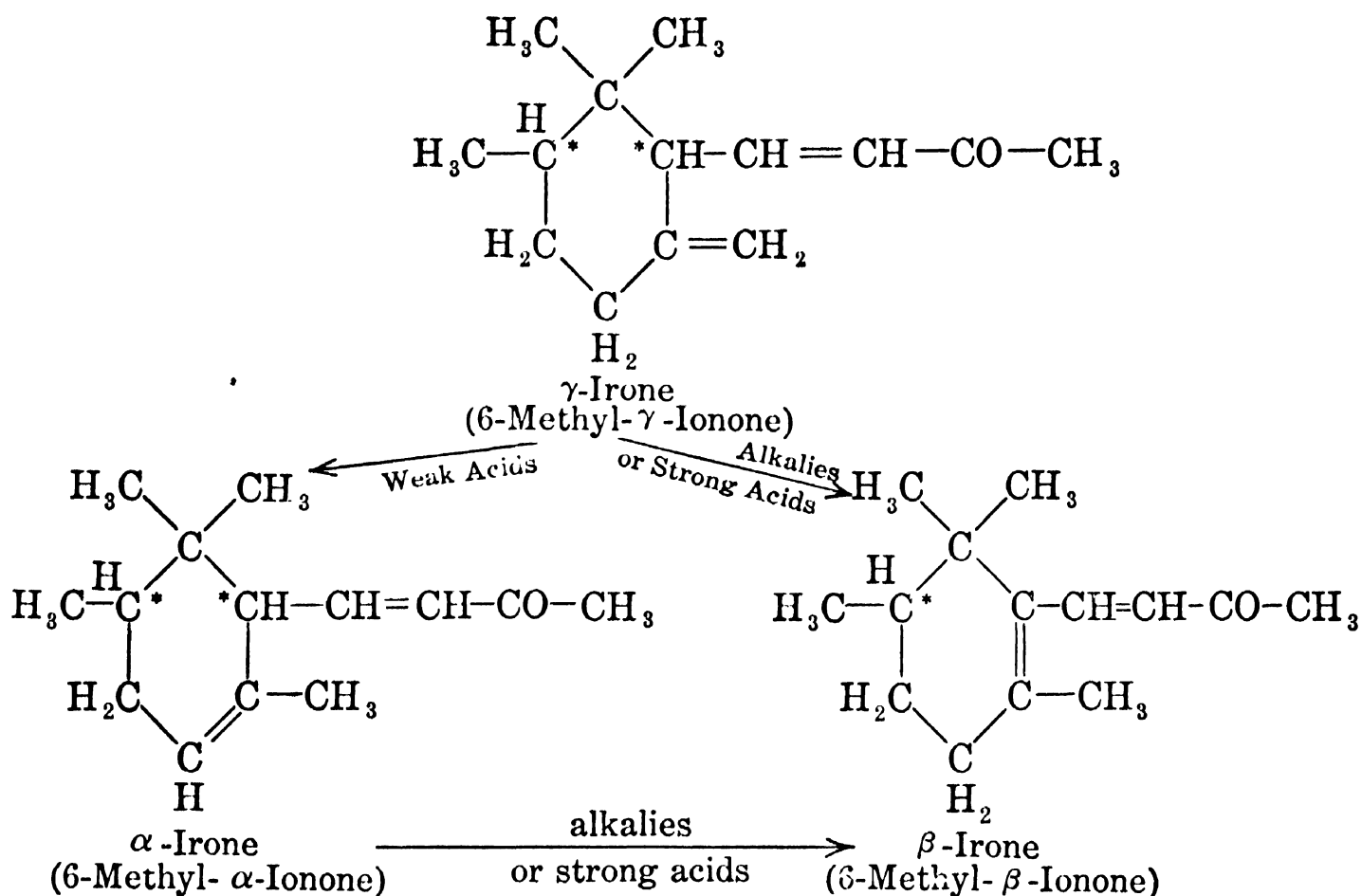

Ironone, a hydroaromatic, unsaturated ketone was first described by Tiemann and Krüger.¹ The extremely small yield of ironone from oil of orris root, and the presence of isomers, have contributed to the considerable difficulties connected with the elucidation of its structure. For a long time the formula suggested by Tiemann and Krüger was accepted as correct, especially since Merling² appeared, at one time, to have succeeded in synthesizing an ironone of the same structure. More than twenty years later, however, Ruzicka, Seidel and Schinz³ proved that the empirical molecular formula of natural ironone is $C_{14}H_{22}O$, and not $C_{13}H_{20}O$ as originally reported by Tiemann and Krüger. Ruzicka and Brugger⁴ also showed that the synthesis achieved by Merling and Welde does not yield ironone, but α -ionone. Gillam and West,⁵ Evans and Gillam,⁶ and Köster⁷ noted that on treatment with acids and alkali, ironone seems to incur a shift in the position of the double bond. Such isomerization resembles that found in the formation of α - and β -ionones, and is partly responsible for the variant physical properties noted for ironones of different origin, or isolated by varying methods.

In the course of their investigations, the above-named workers observed that ironone could be purified in part by the preparation of derivatives (for example, the oxime or the phenylhydrazone) from which the parent ketone could be regenerated. However, the properties of the ketones regenerated from these derivatives (particularly from the thiosemicarbazone) differed from those of the first isolates and suggested that ironone exists in the form of several

isomers. Experiments with oxidative degradation of irone led Ruzicka and collaborators⁸ to the erroneous conclusion that a major component of this mixture of isomers is a ketone with a seven-membered ring.⁹

It is only recently that the six-membered ring formula of irone has been established by Ruzicka and his collaborators, and by Naves and his co-workers—two groups of prominent researchers who independently arrived at similar conclusions.

Ruzicka et al. proved the structure of irone by means of a series of degradation products, which they obtained from tetrahydroirone,¹⁰ from dihydroirone and dihydro-irane,¹¹ and also from irone itself.¹² Naves and Bachmann,¹³ on the other hand, arrived at their conclusion that irone possesses a hexacyclic structure, by a comparison of the Raman spectra of dihydroirone with those of model substances containing six- and seven-membered ring systems.

The two research groups, however, do not quite agree in respect to the uniformity of irone and to the position of one of the double bonds. According to Naves and Bachmann,¹⁴ irone is a chemically well-defined ketone which gives a phenylsemicarbazone m. 162.5°–163°. The natural ketone consists chiefly of 6-methyl- α -ionone, as deduced from the Raman spectra and its similarity to that of α -ionone.

According to Ruzicka, Seidel, Schinz and Pfeiffer,¹⁵ natural irone extracted from orris root contains about 75 per cent of γ -irone (an isomer with a semi-cyclic double bond) and 25 per cent of α -irone. Carefully prepared irone contains only traces of β -irone. These authors found that the phenylsemicarbazone derived from natural irone is a mixture which by fractional crystallization can be divided into many fractions containing different proportions of the derivatives of γ - and α -irone.¹⁶ The highest melting point observed (on the semicarbazone of γ -irone) was 178°–179°.

The presence of γ -irone, the principal constituent of the natural orris ketone, can be inferred from the formation of formaldehyde when irone is treated with ozone.¹⁷ The β,β,γ -trimethyl-pimelic acid, also obtained on treatment of irone with ozone, is not due to the presence of a heptacyclic compound as used to be thought, but to acid splitting from 1,1,2-trimethyl-5-cyclohexanone-6-carboxylic acid, the primary unstable degradation product of γ -irone.¹⁸ On the other hand, the β -keto acid, on ketonic splitting, produces 1,1,2-trimethyl-5-cyclohexanone, a compound isolated from the neutral products of oxidation. The presence of the semicyclic methylene group has been confirmed by a study of the infrared spectra.¹⁹

The α -form, of which the original orris ketone contains about 25 per cent, can be obtained artificially from the γ -form by isomerization under the influence of weak acids (oxalic acid, for example). The mixture of γ - and α -irone, in addition, contains a third isomer, viz., β -irone, the quantity of which seems to vary with the method of preparation. In a mixture of two or all

three isomers, the percentage of each one can be determined by the following rule:²⁰ The amount of γ -irone is proportional to the quantity of formaldehyde formed on ozonization and determined as condensation product with dimedone. The ratio of β -irone can be established by a study of the ultraviolet spectra, pure β -irone showing a maximum at 295 m μ , $\log \epsilon = 4.05$. These two values make it possible to calculate the proportion of α -irone present in the mixture.

Formic acid²¹ is one of the most convenient agents for the quantitative isomerization of γ -irone into a mixture of α - and β -irone. Treatment with strong acids (sulfuric acid) produces mixtures rich in β -irone.²² Alkali, also, is very effective and a great amount of β -irone will be formed. The latter isomer can be obtained in pure state through its crystalline semicarbazone.²³

Syntheses.—Ruzicka et al.²⁴ synthesized *dl*- α - and *dl*- β -irone in the following steps: 2,3-dimethyl-2-hepten-6-one \rightarrow 5-methyl-geraniol \rightarrow pseudo-irone. The α -form was obtained by cyclization under the influence of phosphoric acid, whereas concentrated sulfuric acid gave β -irone.

Naves, Grampoloff and Bachmann,²⁵ working along similar lines and using sulfuric acid for ring closure, obtained an α -irone which, however, seems to consist of another stereoisomeric form different from that prepared by Ruzicka and his co-workers. Naves expressed the opinion that synthetic *dl*- α -irone (phenylsemicarbazone m. 174.5°–175.5°) possesses the *trans*-(2,6) structure, whereas the α -irone isolated from orris root has chiefly the *cis*-(2,6) configuration. (See page 473 for additional work of Naves.)

Possibilities of isomerism.—For α - and γ -irone there exist two possibilities of stereoisomerism: (1) the one between the side chain and methyl group (the isolated one) in respect to the ring. (2) *cis-trans* isomerism in regard to the double bond of the chain. Thus for a synthetic—and consequently optically inactive— α - and γ -irone four different forms may be postulated, whereas for β -irone the number of possible isomers is reduced to two. In the case of natural optically active irone, the number of possible forms is doubled. Theoretically then eight different forms of each α - and γ -irone and four of β -irone can exist.

Occurrence.—*d*-Irone is present in the fraction b₄ 105°–120° of orris root oil—the latter obtained by steam distillation of the dried rhizomes of *Iris florentina*, *I. germanica*, and *I. pallida*. Ten kilograms of orris root yield about 2 g. of irone. The same yield is obtained by extraction of the roots with light petroleum ether.²⁶

Isolation.—The irone can be isolated from oil of orris root in fairly pure state by fractional distillation of the nonacidic portion, using the fraction b₄ 105°–120°. For further purification Girard's reagents P and T are very convenient. Irone can also be regenerated from the crystalline phenylsemicarbazone or from the amorphous semicarbazone by steam distillation in the presence of an aqueous solution of phthalic acid. Hydrolysis of the thiosemicarbazones seems to yield products of lesser purity. The *p*-bromophenylhydrazones resist hydrolysis.

Identification.—A citation of all the different melting points observed in earlier investigations of various derivatives of irone would serve no practical purpose and only add to the confusion, for the simple reason that the earlier workers dealt with mixtures of isomers, the true composition and configuration of which they did not know. (Cf. Gildemeister and Hoffmann,²⁷ Ruzicka et al.²⁸) Gillam and West,²⁹ for instance, prepared derivatives of irones from English, French and German products, and obtained a divergence of melting points indicating the existence of several isomeric irones. French and English irones yielded bromophenylhydrazones melting at 174°–175°, and two thiosemicarbazones, (I) m. 184°–185°, (II) m. 112° (turbid), 131° (clear). On treatment with sulfuric acid, the thiosemicarbazone of a German irone originally melting at 120° was isomerized to a product m. 180°, while the corresponding derivative from an English irone melted at 156°.

The latest investigations of Ruzicka et al., and Naves et al. have helped to clarify the formerly so confused picture:

γ-Irone (isolated from natural irone)

- (1) Phenylsemicarbazone m. 178°–179°³⁰
- (2) Thiosemicarbazone m. 125°–127°³¹

α-Irone (natural irone isomerized)

- (1) Phenylsemicarbazone m. 155°; ³² 160°–161°; ³³ 162.5°–163°³⁴
- (2) Thiosemicarbazone m. 180°³²
- (3) *p*-Bromophenylhydrazone m. 181.5°–182°³⁴
- (4) Dinitro-2,4-phenylhydrazone m. 125.5°–126°³⁴

α-Irone (synthetic ketone)

- (1) Phenylsemicarbazone m. 166°–167°³⁵ (besides amorphous portions); m. 174.5°–175.5°³⁶
- (2) Dinitro-2,4-phenylhydrazone m. 102.5°–103°³⁶

β-Irone (natural irone isomerized)

- (1) Semicarbazone m. 166°–167°; ³⁷ 167°–168°³⁸
- (2) Phenylsemicarbazone m. 160°–161°³⁸
- (3) Thiosemicarbazone m. 166°–167°; ³⁷ 165°–166°³⁸

β-Irone (synthetic ketone)

- (1) Phenylsemicarbazone 164°–166°³⁹ (besides amorphous portions).

Properties.—Natural irone is a slightly viscous oil which (especially in dilution) possesses a strong odor characteristic of violet and dried orris root. In the opinion of Ruzicka and collaborators, the odor of the *α*-isomer is superior to that of the *γ*-isomer, while *β*-irone, on the contrary, has an odor approaching that of the ionones.

Natural Irone

Among earlier investigators, Tiemann and Krüger⁴⁰ first reported for a carefully purified irone:

b_{16}	144°	α_D	about +40° 0'
d_{20}	0.939	n_D^{20}	1.5011

For an irone purified by repeated fractionation and by treatment with *p*-phenylhydrazine sulfonic acid Ruzicka et al.⁴¹ recorded:

b_{20}	146°–152°	α_D	+46° 0'
d_4^{17}	0.9395	n_D^{17}	1.502

and later,⁴² for a genuine irone extracted from orris root by light petroleum ether:

$b_{0.02}$	72°–74°	α_D	+42° 0'
d_4^{15}	0.9387	n_D^{15}	1.5007

On another specimen prepared by steam distillation:

$b_{0.02}$	72°–75°	α_D	+43° 0'
d_4^{15}	0.9410	n_D^{15}	1.5028

For a commercial product of Roure-Bertrand Fils, Grasse, similarly prepared by steam distillation:

$b_{0.02}$	72°–75°	α_D	+46° 0'
d_4^{15}	0.9378	n_D^{15}	1.5007

Naves and Bachmann⁴³ observed these properties:

b_{10}	133°–134°	d_4^{20}	0.9401
b_1	96°–97°	α_D	+32° 20'
		n_D^{20}	1.5016

γ -Irone (from natural irone)

Ruzicka, Schinz, and Seidel⁴⁴ observed on pure γ -irone regenerated from its phenylsemicarbazone (m. 177°–179°) by phthalic acid:

d_4^{15}	0.939
α_D	+22° 0'
n_D^{15}	1.505

α -Irone

Pure α -irone has not yet been isolated either from the naturally occurring mixture of the γ - and α - forms, or from isomerization products, which always contain a certain amount of β -irone.

Naves, Grampoloff, and Bachmann⁴⁵ report for their synthetic *dl*- α -irone

$b_{3.2}$	110°–112°
d_4^{20}	0.9355
n_D^{20}	1.4970

Schinz, Ruzicka, Seidel, and Tavel ⁴⁶ for their synthetic preparation:

$b_{0.01}$	$68^{\circ}-73^{\circ}$
d_4^{19}	0.9345
n_D^{19}	1.5001

and a little later ⁴⁷ for a somewhat purer product:

d_4^{19}	0.9344
n_D^{19}	1.4971

β -Irone

For a β -irone prepared by isomerization of natural irone with concentrated sulfuric acid and by purification through its semicarbazone, Köster ⁴⁸ recorded:

b_2	$97^{\circ}-98^{\circ}$	α_D	$+48^{\circ} 42'$
d_4^{18}	0.9472	n_D^{25}	1.5160

Ruzicka, Seidel, Schinz, and Tavel, ⁴⁹ for an analogous preparation, isomerized with alkali:

$b_{0.1}$	$85^{\circ}-90^{\circ}$	α_D	$+41^{\circ} 36'$
d_4^{15}	0.9485	n_D^{15}	1.5205

and for synthetic *dl*- β -irone:

$b_{0.1}$	93°
d_4^{15}	0.9508
n_D^{15}	1.5198

Hydrogenating natural irone over Raney nickel, Naves and Bachmann ⁵⁰ obtained a dihydro product, the semicarbazone of which melted at $203^{\circ}-203.5^{\circ}$, the dinitro-2,4-phenylhydrazone at $106^{\circ}-106.5^{\circ}$. Using another nickel catalyst Ruzicka and Seidel ⁵¹ obtained a mixture of dihydro- α - and dihydro- γ -irone. They isolated a semicarbazone m. $180^{\circ}-181^{\circ}$, and a small quantity of another semicarbazone m. $170^{\circ}-172^{\circ}$.

Tetrahydro-irone yields a semicarbazone m. $203^{\circ}-204^{\circ}$ ⁵² and some lower melting isomers (Ruzicka et al.). The ketone regenerated from this derivative has these properties:

b_{10}	$135^{\circ}-136^{\circ}$
d_4^{15}	0.925
α_D	$+35^{\circ} 0'$

By means of the Meerwein reaction irone is reduced to irol.⁵³ This very viscous alcohol shows:

b_{13}	136°–140°
d_4^{19}	0.9301
n_D^{19}	1.4941

The highest melting point of the allophanate so far observed is 197°.

On treatment with hydroiodic acid in the presence of red phosphorus, irone loses water and yields a bicyclic hydrocarbon $C_{14}H_{20}$, viz., irene b_9 113°–115°, d_{20} 0.9402, n_D 1.5274, which on dehydrogenation with selenium is converted to 1,2,6-trimethylnaphthalene. Ruzicka, Seidel and Schinz⁵⁴ suggested the following structural formula for irene:

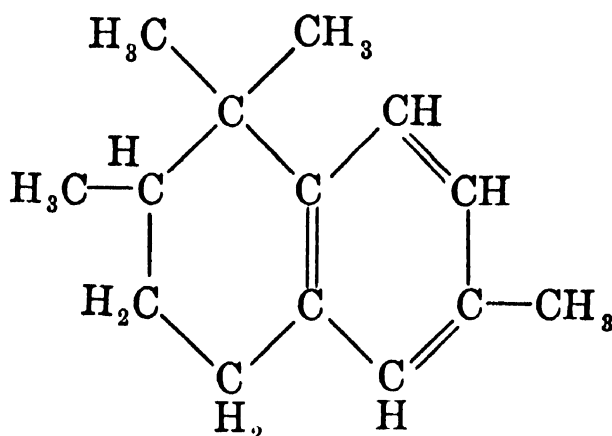

Synthesizing irene from *m*-bromotoluol, Bogert and Apfelbaum⁵⁵ confirmed the correctness of the structural formula pictured above.

Verley⁵⁶ experimented with the synthesis of irone from rhodinal, but according to Ruzicka and Brugger,⁵⁷ the identity of the product thus obtained is questionable.

Use.—Irene is one of the most valuable ingredients in the compounding of fine violet scents used in perfumes and cosmetics. It is usually employed in the form of oil of orris root concrete, or in more concentrated form as oil of orris root tenfold.

¹ *Ber.* **26** (1893), 2675; **28** (1895), 1757; **31** (1898), 808.

² *Ber.* **41** (1908), 2066. Merling and Welde, *Liebigs Ann.* **366** (1909), 129.

³ *Helv. Chim. Acta* **16** (1933), 1143.

⁴ *J. prakt. Chem.* **158** (1941), 125.

⁵ *Nature* **148** (1941), 114. *J. Chem. Soc.* (1942), 95, 484.

⁶ *J. Chem. Soc.* (1943), 565.

⁷ *Ber.* **77**, No. 8 (1944), 559.

⁸ *Helv. Chim. Acta* **16** (1933), 1143, 1150; **23** (1940), 935, 959; **24** (1941), 1434; **25** (1942), 188, 199.

⁹ Cf. Simonsen, "The Terpenes," 2d Ed., Vol. I, 130. Cambridge Univ. Press, 1947.

¹⁰ Ruzicka, Seidel and Brugger, *Helv. Chim. Acta* **30** (1947), 2168.

¹¹ Ruzicka and Seidel, *ibid.* **31** (1948), 160.

¹² Ruzicka, Seidel, Schinz, and Tavel, *ibid.*, 257.

¹³ *Ibid.* **30** (1947), 2222 (sealed paper of June 10, 1943), 2233, 2241.

¹⁴ *Ibid.*, 2230.

¹⁵ *Ibid.*, 1807 (sealed paper of June 28, 1946). See also Ruzicka, Seidel, and Schinz, *ibid.* **31** (1948), 257.

- ¹⁶ Ruzicka, Seidel, and Schinz, *ibid.* **16** (1933), 1143.
- ¹⁷ Ruzicka, Seidel, Schinz, and Pfeiffer, *ibid.* **30** (1947), 1807. Ruzicka et al., *ibid.* **31** (1948), 257.
- ¹⁸ Ruzicka, Seidel, Schinz, and Tavel, *ibid.* **31** (1948), 257.
- ¹⁹ Günthard and Ruzicka, *ibid.*, 642.
- ²⁰ Ruzicka, Seidel, Schinz, and Tavel, *ibid.* **30** (1947), 266.
- ²¹ *Ibid.*
- ²² Ruzicka, Seidel, and Firmenich, *ibid.* **24** (1941), 1434. Cf. Köster, *Ber.* **77** (1944), 559.
- ²³ Köster, *Ber.* **77** (1944), 559. Ruzicka, Seidel, Schinz, and Tavel, *Helv. Chim. Acta* **31** (1948), 257.
- ²⁴ *Helv. Chim. Acta* **30** (1947), 1810 (sealed paper of June 28, 1946). See also *ibid.* **31** (1948), 422.
- ²⁵ *Ibid.* **30** (1947), 1599. Naves, *ibid.* **31** (1948), 893.*
- ²⁶ Ruzicka, Seidel, Schinz, and Tavel, *ibid.* **31** (1948), 257.
- ²⁷ "Die Ätherischen Öle," 3d Ed., Vol. I, 592. Chuit, *Rev. gen. chim.* **6** (1903), 433.
- ²⁸ *Helv. Chim. Acta* **16** (1933), 1143, 1150; **23** (1940), 935, 959; **24** (1941), 1434.
- ²⁹ *J. Chem. Soc.* (1942), 95, 484.
- ³⁰ Ruzicka, Seidel, and Schinz, *Helv. Chim. Acta* **16** (1933), 1143.
- ³¹ Ruzicka, Seidel, Schinz, and Tavel, *ibid.* **31** (1948), 257.
- ³² Ruzicka, Seidel, and Firmenich, *ibid.* **24** (1941), 1434. Isomerization effected by dilute sulfuric acid in the heat.
- ³³ Ruzicka, Seidel, Schinz, and Tavel, *ibid.* **31** (1948), 257. Isomerization effected by formic acid.
- (Note to **32** and **33**: Inasmuch as pure α -irone has not yet been isolated from the mixture of α - and β -ketones, the authors give these melting points with a certain reserve.)
- ³⁴ Naves and Bachmann, *Helv. Chim. Acta* **30** (1947), 2222. The indicated derivatives are those obtained from natural irone, which these authors consider to be α -irone.
- ³⁵ Schinz, Ruzicka, Seidel, and Tavel, *ibid.*, 1814.
- ³⁶ Naves, Grampoloff, and Bachmann, *ibid.*, 1608. Naves, *ibid.*, **31** (1948), 893.
- ³⁷ Köster, *Ber.* **77** (1944), 559. Isomerization effected by concentrated sulfuric acid.
- ³⁸ Ruzicka, Seidel, Schinz, and Tavel, *Helv. Chim. Acta* **31** (1948), 257. Isomerization effected with alkali.
- ³⁹ *Ibid.*
- ⁴⁰ *Ber.* **26** (1893), 2675. Cf. Gildemeister and Hoffman, "Die Ätherischen Öle," 3d Ed., Vol. I, 592.
- ⁴¹ *Helv. Chim. Acta* **16** (1933), 1143.
- ⁴² *Ibid.* **31** (1948), 271.
- ⁴³ *Ibid.* **30** (1947), 2226.
- ⁴⁴ *Ibid.* **16** (1933), 1143.
- ⁴⁵ *Ibid.* **30** (1947), 1608.
- ⁴⁶ *Ibid.*, 1810.
- ⁴⁷ *Ibid.* **31** (1948), 279.
- ⁴⁸ *Ber.* **77** (1944), 559.
- ⁴⁹ *Helv. Chim. Acta* **31** (1948), 257.
- ⁵⁰ *Ibid.* **30** (1947), 2231.
- ⁵¹ *Ibid.* **31** (1948), 160.
- ⁵² *Ibid.* **24** (1941), 1437; **30** (1947), 2168; see also *ibid.* **2** (1919), 352.
- ⁵³ Ruzicka, Seidel, Schinz, and Tavel, *ibid.* **31** (1948), 257.
- ⁵⁴ *Ibid.* **16** (1933), 1143. ⁵⁶ *Bull. soc. chim.* [5], **2** (1935), 1205.
- ⁵⁵ *J. Am. Chem. Soc.* **60** (1938), 930. ⁵⁷ *J. prakt. Chem.* **158** (1941), 125.

* In his latest publication, Naves [*Helv. Chim. Acta* **31** (1948), 1876] reports that in oil of orris root he identified *cis*-(2,6) α -irone, and *trans*-(2,6) α -irone, the phenyl-4-semicarbazones of which melt at 162°–163° (*dl*: 164.5°–165°), and at 174.5°–175.5°, respectively. Naves also identified neo- α -irone (*b*_{2,3} 107°–108°, *d*₄²⁰ 0.9347, α _D –8° 15'; phenyl-4-semicarbazone 181°–182°) among the natural constituents of orris root oil.

F. AROMATIC KETONES

Introduction.—Aromatic ketones are even more rare in essential oils than are the aliphatic ketones. Some of the synthetic compounds, however, have attained considerable importance in the perfume and especially in the soap industry as they possess a powerful aromatic odor.

Acetophenone

C₈H₈O

Mol. Weight 120.14

Methyl phenyl ketone. Acetylbenzene. Hypnone

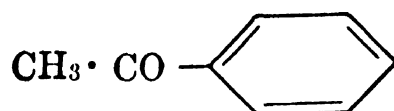

Occurrence.—Acetophenone is the main constituent of oil of *Stirlingia latifolia*.

Isolation.—By fractional distillation, cooling of the corresponding fraction, and recrystallization.

Identification.—Acetophenone can be characterized by several methods:

(1) Through the sodium nitroprusside color test, according to Mulliken:¹

To 2 cc. of a cold saturated aqueous solution of acetophenone add 2 drops of a 1% aqueous sodium nitroprusside solution and then 2 drops of 10% sodium hydroxide solution. Divide into two equal parts, viz., *a* and *b*, adding to *b* 3 drops of glacial acetic acid. Part *b* on acidification turns blue, while part *a* is red changing to yellow in 20 min.

(2) By the preparation of derivatives:

(a) Semicarbazone m. 198°–199° corr. (from 50% alcohol), according to Shriner and Turner;² m. 197°, according to Wilson and Keenan;³ m. 201°–203°, according to Gilman and Nelson.⁴

(b) Phenylhydrazone m. 105° (from alcohol), according to Fischer,⁵ and Ardagh and collaborators⁶ who point out that the white crystals rapidly darken on exposure to air. The phenylhydrazone is prepared by shaking an aqueous solution of acetophenone with an aqueous solution of phenylhydrazine hydrochloride and sodium acetate.

(c) 2,4-Dinitrophenylhydrazone m. 249°–250° (from glacial acetic acid), according to Campbell;⁷ m. 238°–240°, according to Discherl and Nahm.⁸ (Cf. also Allen.⁹)

(d) Hydrazone from *N*-methyl- β -carbohydrazidopyridinium *p*-toluene sulfonate m. 191°, by Allen and Gates.¹⁰

(e) *p*-Iodobenzohydrazone m. 212° (corr.), by Sah and Hsü.¹¹

Properties.—Acetophenone has a powerful, peculiar, sweet, and aromatic odor.

The following properties have been reported by Timmermans and Hennaut-Roland,¹² Brühl,¹³ Perkin,¹⁴ Noller and Adams,¹⁵ Senderens,¹⁶ Norris and Sturgis,¹⁷ and Gilman and Nelson:¹⁸

m. range	19.5°–20.5° ^{12,15,16,17}	d_4^{20}	1.02810 ¹²
b.	202° ¹²	d_{15}^{15}	1.0329 ¹⁴
b ₇₄₆	201.5° ¹⁶ (corr.)	$n_D^{19.6}$	1.53418 ¹³
b ₂₀	94.5° ¹³	n_D^{15}	1.53631 ¹²
b ₁₃	87° ¹⁸		

Acetophenone is almost insoluble in water, soluble in organic solvents, and in concentrated sulfuric acid with orange-yellow color. It is volatile with steam. This ketone does not form an addition compound with sodium bisulfite.

On oxidation with potassium bichromate and sulfuric acid or with sodium hypochlorite solution, acetophenone, according to van Arendonk and Cupery,¹⁹ yields benzoic acid.

Use.—Acetophenone is used in perfumes of the floral type, especially hawthorn, wistaria, lilac, mimosa and foin-coupé. Because of its powerful odor and low price, acetophenone is a valuable adjunct in the scenting of soaps. It, furthermore, serves in all kinds of technical preparations where efficient odor coverage is required.

¹ "Identification of Pure Organic Compounds," Vol. I, New York, Wiley (1904), 149.

² *J. Am. Chem. Soc.* **52** (1930), 1269.

³ *J. Assocn. Official Agr. Chem.* **13** (1930), 390.

⁴ *Rec. trav. chim.* **55** (1936), 529.

⁵ *Ber.* **17** (1884), 576.

⁶ *J. Am. Chem. Soc.* **54** (1932), 721.

⁷ *Analyst* **61** (1936), 393.

⁸ *Ber.* **73** (1940), 450.

⁹ *J. Am. Chem. Soc.* **52** (1930), 2955.

¹⁰ *J. Org. Chem.* **6** (1941), 600.

¹¹ *Rec. trav. chim.* **59** (1940), 352.

¹² *J. chim. phys.* **32** (1935), 524.

¹³ *J. prakt. Chem.* [2], **50** (1894), 131.

¹⁴ *J. Chem. Soc.* **69** (1896), 1200.

¹⁵ *J. Am. Chem. Soc.* **46** (1924), 1893.

¹⁶ *Ann. chim. phys.* [8], **28** (1913), 312.

¹⁷ *J. Am. Chem. Soc.* **61** (1939), 1417.

¹⁸ *Rec. trav. chim.* **55** (1936), 528.

¹⁹ *J. Am. Chem. Soc.* **53** (1931), 3184.

***p*-Methylacetophenone**C₉H₁₀O

Mol. Weight 134.17

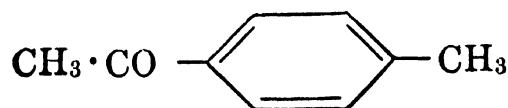
Methyl-*p*-tolyl ketone. *p*-Acetyltoluene

Occurrence.—Naves¹ identified this aromatic ketone in the volatile oils derived from the wood of the Brazilian Cabreuva tree (*Myrocarpus fastigiatus* and *M. frondosus* Allem.), and of the rosewood tree (bois de rose). Cerbelaud² has suggested that the ketone is a possible constituent of mimosa flower oil.

Isolation.—According to Naves,³ by fractional distillation *in vacuo*, and by conversion of the ketone into its semicarbazone, which is very sparingly soluble in cold methyl alcohol. The semicarbazone can be decomposed by treatment with a 10% aqueous solution of oxalic acid; the regenerated ketone is removed by steam distillation.

Identification.—*p*-Methylacetophenone may be characterized by the preparation of several derivatives:

(1) Semicarbazone m. 209°–210° (crystallized from alcohol), according to Naves;⁴ m. 210°, according to Wilson and Keenan.⁵ Sorge,⁶ and Rupe and Steinbach⁷ reported a melting point of 204°–205° (needles or plates from alcohol).

(2) 2,4-Dinitrophenylhydrazone m. 259°–260° (crystallized from ethyl acetate), according to Naves;⁸ m. 260.4° (from toluene), according to Ferrante and Bloom.⁹

(3) *p*-Iodo-benzohydrazone m. 214°, according to Sah and Hsü.¹⁰

(4) Oxime m. 88° (crystallized from petroleum ether), by Naves.¹¹

Properties.—*p*-Methylacetophenone is an oil (at room temperature) of powerful odor, reminiscent of blooming hawthorn. The following properties have been reported by Naves,¹² Gildemeister and Hoffmann,¹³ Groggins and Nagel,¹⁴ and Noller and Adams.¹⁵

m.	−23° ¹⁴ (reported incorrectly as −28° in Beilstein and elsewhere)	d ₂₀	1.0051 ¹⁵
		d ₄ ²⁰	1.0016 ¹²
		d ₁₅ ¹⁵	1.007–1.014 ¹³
b ₇₆₄	226.7° ± 0.2° ¹⁴	n _D ²⁰	1.5335 ^{12,15}
b ₇₅₆	222°–226° ¹³		1.5331 ¹⁴
b ₇₃₆	225° ¹⁵ (corr.)	Sol.	Soluble in about 3 vol. of 60% alcohol. ¹³
b ₇	93.5° ¹⁵ (vac. corr.)		
b _{1.3}	68° ¹²		

When oxidized with excess alkaline sodium hypochlorite, *p*-methylacetophenone yields *p*-toluic acid m. 178°, according to van Arendonk and Cupery;¹⁶ m. 180°–180.5° (crystallized from acetic acid 50 per cent), according to Naves.¹⁷ Oxidizing the ketone with potassium permanganate, Claus¹⁸ obtained almost quantitatively terephthalic acid which sublimes without melting at about 300°.

Reduction of *p*-methylacetophenone with sodium and alcohol yields, according to Klages and Keil,¹⁹ methyl-*p*-tolyl carbinol b. 219°; reduction with 5 per cent sodium amalgam in 70 per cent alcohol gives, according to Claus,²⁰ methyl-*p*-tolyl pinacone m. 90° (uncorr.) (crystallized from alcohol).

Use.—*p*-Methylacetophenone is used widely in perfumes of the floral type, especially hawthorn, lilac, mimosa and cassie. Because of its powerful odor and low price, it serves as a valuable adjunct in the scenting of soaps.

- ¹ Private communication of Dr. Y. R. Naves, Geneva, during publication of this book. Cf. *Helv. Chim. Acta* **31** (1948), 44.
² *Parfumerie moderne* May (1926), 99. *Chemist & Druggist* **105** (1926), 201.
³ Private communication. Cf. *Helv. Chim. Acta* **31** (1948), 44.
⁴ *Ibid.*
⁵ *J. Assocn. Official Agr. Chem.* **13** (1930), 390, 395.
⁶ *Ber.* **35** (1902), 1070.
⁷ *Ber.* **43** (1910), 3465.
⁸ Private communication. Cf. *Helv. Chim. Acta* **31** (1948), 44.
⁹ *Am. J. Pharm.* **105** (1933), 383.
¹⁰ *Rec. trav. chim.* **59** (1940), 352.
¹¹ Private communication. Cf. *Helv. Chim. Acta* **31** (1948), 44.
¹² *Ibid.*
¹³ "Die Ätherischen Öle," 3d Ed., Vol. I, 554.
¹⁴ *Ind. Eng. Chem.* **26** (1934), 1315.
¹⁵ *J. Am. Chem. Soc.* **46** (1924), 1893.
¹⁶ *Ibid.* **53** (1931), 3184.
¹⁷ Private communication. Cf. *Helv. Chim. Acta* **31** (1948), 44.
¹⁸ *Ber.* **19** (1886), 234.
¹⁹ *Ber.* **36** (1903), 1635.
²⁰ *J. prakt. Chem.* [2], **41** (1890), 403.

o-Hydroxyacetophenone

C₈H₈O₂

Mol. Weight 136.14

o-Acetylphenol

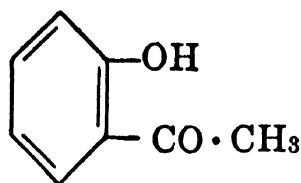

Occurrence.—*o*-Acetylphenol occurs as such and possibly as methyl ether in oil of *Chione glabra*.

Isolation.—By fractional distillation, cooling of the fraction, and recrystallization.

Identification.—*o*-Hydroxyacetophenone can be characterized by several methods:

- (1) With ferric chloride it gives an intense reddish-violet color.
- (2) By the preparation of several derivatives:
 - (a) Semicarbazone m. 209°–210°, according to Cope,¹ and Pauly and Lockemann.²
 - (b) Phenylhydrazone m. 109°–110°, according to Torrey and Brewster;³ m. 108°–108.5° (corr.), according to Bogert and Marcus.⁴
 - (c) α -Naphthoate m. 108° and β -naphthoate 119°, according to Virkar and Shah.⁵

Properties.—The following properties have been reported by von Auwers,⁶ and Shriner and Sharp:⁷

b.	215°–220° ⁷	d_4^{20}	1.131 ⁶
b ₁₄	100° ⁶	n_D^{20}	1.5593 ⁶
Sol.	Sparingly soluble in water, soluble in alcohol, ether, etc.		

o-Hydroxyacetophenone is volatile with steam, while its *p*-isomer is not volatile with steam.

Pauly and Lockemann⁸ suggested separating *o*-hydroxyacetophenone from phenol through its copper derivative.

Use.—*o*-Hydroxyacetophenone is used very little, if at all, in perfumes or flavors.

¹ *J. Am. Chem. Soc.* **57** (1935), 574.

² *Ber.* **48** (1915), 30.

³ *J. Am. Chem. Soc.* **35** (1913), 441.

⁴ *Ibid.* **41** (1919), 97.

⁵ *J. Univ. Bombay* **11**, Pt. 3 (1942), 140.

⁶ *Liebigs Ann.* **408** (1915), 245.

⁷ *J. Org. Chem.* **4** (1939), 575.

⁸ *Ber.* **48** (1915), 30.

p-Methoxyacetophenone

C₉H₁₀O₂

Mol. Weight 150.17

p-Anisyl methyl ketone. *p*-Acetylanisole. "Crataegon"

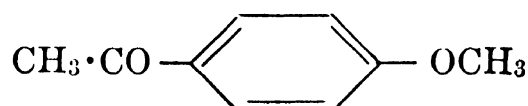

Occurrence.—This ketone has not been reported as a natural constituent of essential oils.

Isolation.—*p*-Methoxyacetophenone could be isolated from volatile oils by cooling the corresponding fraction to a low temperature, and by recrystallization.

Identification.—By the preparation of several derivatives:

(1) *p*-Nitrophenylhydrazone m. 195°–195.5° (orange leaflets from alcohol), according to Unger.¹

(2) 2,4-Dinitrophenylhydrazone m. 220° (corr.), according to Allen and Richmond;² m. 231.8° (corr.), according to Ferrante and Bloom;³ m. 233°–234° by Borsche and Barthenheier.⁴

(3) *o*-Chlorbenzohydrazone m. 125°–126° by Sun and Sah;⁵ *p*-nitrobenzohydrazone m. 199°–200° by Chen.⁶

(4) Anisal-bis-(*p*-methoxyacetophenone) from anisaldehyde and *p*-methoxyacetophenone, m. 104°–105°; disemicarbazone m. 235°–237° (1° per second heating), according to Schneider and Gramms.⁷

Properties.—*p*-Methoxyacetophenone is a crystalline mass possessing a powerful, lasting odor reminiscent of *p*-methylacetophenone, heliotrope, and syringa.

The following properties have been reported by Gildemeister and Hoffmann,⁸ Gattermann, Ehrhardt and Maisch,⁹ von Auwers,¹⁰ and Gilman and Nelson:¹¹

cong. pt.	34.7° ⁸	$d_4^{41.1}$	1.0818 ¹⁰
b.	258° ⁹	d_{25}	1.0959 ⁸
b_{36}	158° ⁸	d_{20}	1.0997 ⁸
b_{13}	138° ¹¹	n_D^{25}	1.55489 ⁸
b_{10}	136° ⁸		
Sol. at 20°	Soluble in 4–5 vol. and more of 50% alcohol; slightly soluble in water ⁸		

When treated with excess alkaline sodium hypochlorite in cold methanol solution, *p*-methoxyacetophenone yields *p*-methoxybenzoic acid m. 184°, according to van Arendonk and Cupery.¹² On oxidation with potassium permanganate in alkaline solution, the ketone gives *p*-methoxyphenylglyoxylic acid m. 90° (anhydrous needles from benzene), according to Kögl and Becker.¹³ Von Wacek and Bézard¹⁴ found that degradation with peracetic acid yielded *p*-hydroxyanisole.

Use.—*p*-Methoxyacetophenone is used like *p*-methylacetophenone but in products of higher grade.

¹ *Liebigs Ann.* **504** (1933), 279.

² *J. Org. Chem.* **2** (1937), 224.

³ *Am. J. Pharm.* **105** (1933), 383.

⁴ *Liebigs Ann.* **553** (1942), 254.

⁵ *Sci. Repts. Natl. Tsinghua Univ.* [A], **2** (1934), 359. *Chem. Abstracts* **29** (1935), 466.

⁶ *J. Chinese Chem. Soc.* **3** (1935), 251. *Chem. Abstracts* **29** (1935), 7229.

⁷ *Ber.* **69** (1936), 2543.

⁸ "Die Ätherischen Öle," 3d Ed., Vol. I, 554.

⁹ *Ber.* **23** (1890), 1201.

¹² *J. Am. Chem. Soc.* **53** (1931), 3184.

¹⁰ *Liebigs Ann.* **408** (1915), 247.

¹³ *Liebigs Ann.* **465** (1928), 236.

¹¹ *Rec. trav. chim.* **55** (1936), 529.

¹⁴ *Ber.* **74B** (1941), 845.

p-Methoxyphenylacetone

$C_{10}H_{12}O_2$

Mol. Weight 164.20

Anisketone

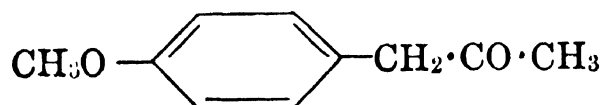

Occurrence.—*p*-Methoxyphenylacetone possibly occurs in Russian oil of anise, in oil of fennel, sweet and bitter. Tardy¹ reported its occurrence in Chinese star anise oil.

Isolation.—By fractional distillation, after separation of the product by means of the bisulfite complex, according to Tardy.²

Identification.—Anisketone can be characterized by the preparation of several derivatives:

(1) It forms two oximes, according to Hoering; ³ I m. 78°–79°, II m. 61°–62°.

(2) Semicarbazone m. 182°, according to Behal and Tiffeneau.⁴

On oxidation with moist silver oxide, anisketone gives, according to Tardy,⁵ anisic acid m. 183°.

When treated with iodine and potassium hydroxide, anisketone yields iodoform and 4-methoxyphenylacetic acid, according to Tiffeneau and Daufresne.⁶

Properties.—Anisketone is an oil with an odor reminiscent of anise.

The following properties have been reported by Gildemeister and Hoffmann,⁷ Balbiano,⁸ Hoering,⁹ and Wallach and Müller:¹⁰

f.p.	−15° ⁸	d_{17}^{17}	1.0707 ⁹
b.	267°–269° (corr.) ⁹	d_0	1.095 ⁷
b_{10}	136°–137° ³	n_D^{20}	1.5253 ¹⁰

Anisketone is not easily volatile with steam; it is somewhat soluble in water, readily soluble in alcohol, ether, etc.

Use.—Anisketone is used very little in the perfume and flavor industries.

¹ *Bull. soc. chim.* [3], **27** (1902), 990.

² *Ibid.*

³ *Ber.* **38** (1905), 3480.

⁴ *Compt. rend.* **141** (1905), 597.

⁵ *Bull. soc. chim.* [3], **27** (1902), 990.

⁶ *Compt. rend.* **144** (1907), 1356.

⁷ "Die Ätherischen Öle," 3d Ed., Vol. I, 555.

⁸ *Atti accad. Lincei* [5], **17**, II (1908), 262.

⁹ *Ber.* **38** (1905), 3480.

¹⁰ *Liebigs Ann.* **332** (1904), 324.

G. MISCELLANEOUS KETONES

d-1-Methyl-3-cyclohexanone

$C_7H_{12}O$

Mol. Weight 112.17

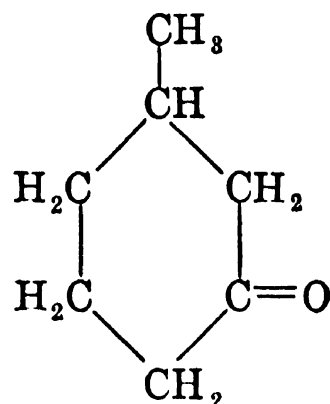

Pulegone, on boiling with anhydrous formic acid, or with alkali, or on heating with water at 250° in an autoclave, takes up water and is split into acetone and *d*-1-methyl-3-cyclohexanone (Wallach).¹

Occurrence.—*d*-1-Methyl-3-cyclohexanone was first observed by Barrowcliff² in the fraction b. 165°–170° of American oil of pennyroyal (*Hedeoma pulegioides* [L.] Pers.), after the oil had been freed from pulegone by treatment with bisulfite solution.

According to Naves,³ small quantities of *d*-1-methyl-3-cyclohexanone occur in the European type of oil of pennyroyal (*Mentha pulegium* L.). Bohnsack⁴ isolated this ketone from the foreruns of Java citronella oil.

Isolation.—Barrowcliff⁵ isolated *d*-1-methyl-3-cyclohexanone from the fraction 165°–170° of American oil of pennyroyal by preparing the semicarbazone and regenerating the parent ketone from its semicarbazone.

Identification.—(1) By preparation of the oxime m. 41°–43° (Barrowcliff⁶).

(2) By preparation of the semicarbazone m. 182°–183° (Barrowcliff⁷), m. 178°–178.5° (Naves⁸), m. 181°–182° (Bohnsack⁹).

(3) On oxidation with potassium permanganate in alkaline solution, *d*-1-methyl-3-cyclohexanone yields β -methyl adipic acid m. 85°–86° (Bohnsack¹⁰).

Properties.—The following properties have been reported by Wallach,¹¹ Tiemann and Schmidt,¹² Tschugaev,¹³ Barrowcliff,¹⁴ Bohnsack,¹⁵ and Naves:¹⁶

b.	169° ¹¹	$[\alpha]_D^{20}$	+1° 12' (2 g. oil + 3 g. ether in a 5 cm. tube) ¹⁵
b.	167°–168° ¹⁴		
b ₁₆	58° ¹⁵	$[\alpha]_D^{20}$	+12° 42' (undiluted) ¹³
b ₂	52.0°–52.5° ¹⁶		+11° 58' (c = 11.4 in benzene) ¹³
d ₂₁	0.915 ¹¹		
d ₄ ²⁰	0.9155 ¹⁶		+8° 9' (c = 11.5 in methanol) ¹³
d ₂₀	0.9071 (from pulegone) ¹²		
	0.9115 (from isopulegone) ¹²		+10° 35' (c = 11 in ether) ¹³
d ₁₅ ¹⁶	0.9176 ¹⁵		
		$[\alpha]_D^{15}$	+13° 23' ¹¹
		$[\alpha]_D$	+12° 55' ¹⁶
		n _D ²¹	1.4456 ¹¹
		n _D ²⁰	1.4439 ¹⁶

Use.—*d*-1-methyl-3-cyclohexanone, as such, is not used in our industries.

¹ *Liebigs Ann.* **289** (1896), 338, 340; **365** (1909), 243. Cf. Tiemann and Schmidt, *Ber.* **30** (1897), 23.

² *J. Chem. Soc.* **91** (1907), 879.

³ *Helv. Chim. Acta* **26** (1943), 162.

⁴ *Ber.* **76** (1943), 564.

⁵ *J. Chem. Soc.* **91** (1907), 879.

⁶ *Ibid.*

⁷ *Ibid.*

⁸ *Helv. Chim. Acta* **26** (1943), 169.

⁹ *Ber.* **76** (1943), 567.

¹⁰ *Ibid.* Cf. Wallach, *Liebigs Ann.* **289** (1896), 344, 345. *Ber.* **32** (1899), 3339.

¹¹ *Liebigs Ann.* **289** (1896), 338, 339; **332** (1904), 337.

¹² *Ber.* **30** (1897), 23.

¹³ *Z. physik. Chem.* **76** (1911), 472.

¹⁴ *J. Chem. Soc.* **91** (1907), 875.

¹⁵ *Ber.* **76** (1943), 571.

¹⁶ *Helv. Chim. Acta* **26** (1943), 162.

l-1-Methyl-4-acetyl-1-cyclohexene

C₉H₁₄O

Mol. Weight 138.20

p-Methyl-3-tetrahydroacetophenone

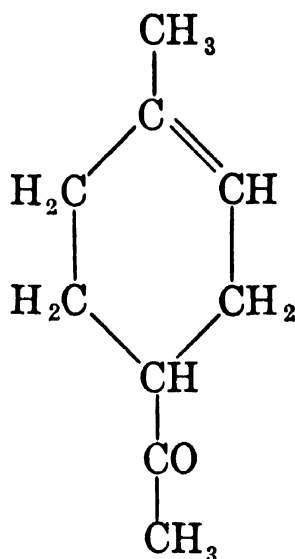

Occurrence.—Roberts¹ isolated from Himalaya cedar oil (deodar tree) through the semicarbazone m. 163°–164°, 2% of a ketone, very probably *p*-methyl-3-tetrahydroacetophenone which possessed the characteristic odor of this oil.

More recently, Naves² identified this cyclic ketone in the volatile oil derived from the wood of the Brazilian Cabreuva tree (*Myrocarpus fastigiatus* and *M. frondosus* Allem.).

Isolation.—By fractionation of the oil *in vacuo*, elimination of the aldehydes and ketones which react with sodium sulfite solution, and by conversion into the semicarbazone. The latter can be decomposed by treatment with a 10% aqueous solution of oxalic acid; the free ketone is then removed by steam distillation.

Identification.—(1) According to Naves,³ by preparation of the semicarbazone m. 156°–156.5° (crystallized from methanol). Roberts⁴ reported for the semicarbazone a melting point of 163°–164°.

(2) According to Naves,⁵ by catalytic hydrogenation into saturated ketone, viz., hexahydro-*p*-methyl acetophenone, and by preparation of the semicarbazones of the two stereoisomeric forms, m. 158°–161° and 182°–183°, respectively (crystallized from methanol).

(3) According to Naves,⁶ by oxidation with concentrated sulfuric acid at 100° into *p*-methyl acetophenone, which can be identified by the preparation of its semicarbazone m. 209°–210° (crystallized from alcohol), and of its dinitro-2,4-phenylhydrazone m. 257°–259° (crystallized from ethyl acetate).

(4) Roberts⁷ prepared the dibromo-oxime m. 130°.

Properties.—Stephan and Helle ⁸ reported these properties of *p*-methyl-3-tetrahydroacetophenone:

b_4	68.5°–70°
d_{15}^{15}	0.9435
n_D^{15}	1.47421

For the natural product, Naves ⁹ recorded

$b_{3.3}$	61°	$[\alpha]_D^{20}$	–35° 6′
d_4^{20}	0.9371	n_D^{20}	1.4711

Oxidation with a solution of hypobromite (without cooling) yields *p*-toluic acid m. 179°–180°.

The ketone is volatile with steam.

Use.—*l*-1-Methyl-4-acetyl-1-cyclohexene, as such, is not used in our industries.

¹ *J. Chem. Soc.* **109** (1916), 791.

² Private communication of Dr. Y. R. Naves, Geneva, during publication of this book. Cf. *Helv. Chim. Acta* **31** (1948), 29, 44.

³ *Ibid.*

⁴ *J. Chem. Soc.* **109** (1916), 791.

⁵ Private communication. Cf. *Helv. Chim. Acta* **31** (1948), 29, 44.

⁶ *Ibid.*

⁷ *J. Chem. Soc.* **109** (1916), 791.

⁸ *Ber.* **35** (1902), 2151.

⁹ Private communication. Cf. *Helv. Chim. Acta* **31** (1948), 29, 44.

Perilla Ketone

C₁₀H₁₄O₂

Mol. Weight 166.21

β-Furyl-isopentyl-ketone

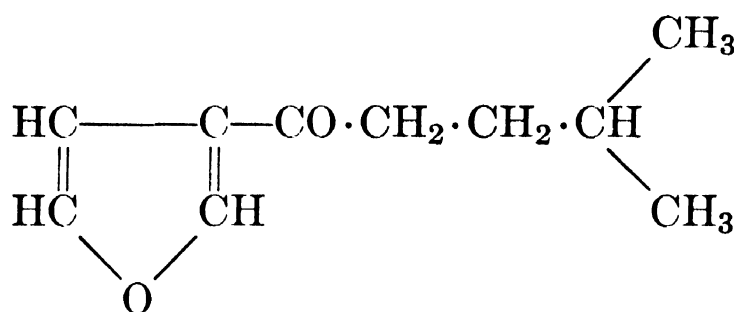

Occurrence.—Perilla ketone is the main constituent in the essential oil obtained on steam distillation of the fresh herb *Perilla frutescens* Brit. fam. *Labiatae*. More than 90 per cent of the oil distills at b_{20} 118°–119°.

Isolation.—Perilla ketone forms an oxime C₁₀H₁₅O₂N, m. 67° (from alcohol), from which the parent ketone can be regenerated by cleavage with dilute sulfuric acid.

The structural formula of perilla ketone was established by Goto.¹

Identification.—Perilla ketone can be characterized by the preparation of its

(1) oxime m. 67° (Goto ²), m. 66°–67° (Sebe ³).

(2) semicarbazone which crystallizes in the form of colorless needles m. 98°–99° (Goto), m. 93°–94° (Sebe).

Properties.—Goto, ⁴ and Sebe ⁵ reported these properties for perilla ketone:

b_7	90°–100° ⁵	n_D^{25}	1.4781 ⁴
d_{24}^{25}	0.99002 ⁴	n_D^{24}	1.4764 ⁵
d_4^{24}	0.9842 ⁵	Mol. refr.	47.18 ⁴
α_D	$\pm 0^\circ$ ⁴		
$[\alpha]_D^{24}$	$-1^\circ 36'$ ⁵		

On oxidation with potassium permanganate perilla ketone yields isocaproic acid b. 203°–204°, anilide m. 112°.

Use.—Perilla ketone, as such, is used very little in our industries.

¹ *J. Pharm. Soc. Japan* **57** (1937), 17. *Chem. Zentr.* II (1937), 2082.

² *Ibid.*

³ *J. Chem. Soc. Japan* **64** (1943), 1130. *Chem. Abstracts* **41** (1947), 3785.

⁴ *J. Pharm. Soc. Japan* **57** (1937), 17. *Chem. Zentr.* II (1937), 2082.

⁵ *J. Chem. Soc. Japan* **64** (1943), 1130. *Chem. Abstracts* **41** (1947), 3785.

Angustione

and

Dehydroangustione

Years ago Penfold,¹ when treating oil of *Backhousia angustifolia* F. Müll. with sodium hydroxide solution, isolated a substance C₁₀H₁₄O₃ which could be purified by the compounds formed with ammonia and with copper. A later investigation by Gibson, Penfold and Simonsen,² and by the same authors in collaboration with Cahn ³ proved that the new substance consisted of two new β -diketones, viz., angustione C₁₁H₁₆O₃, and dehydroangustione C₁₁H₁₄O₃. Both substances are the first β -diketones identified in nature; they contain the ionone ring. Since their first isolation they have been reported by Penfold ⁴ to occur in many Australian essential oils.

Angustione

 $C_{11}H_{16}O_3$

Mol. Weight 196.24

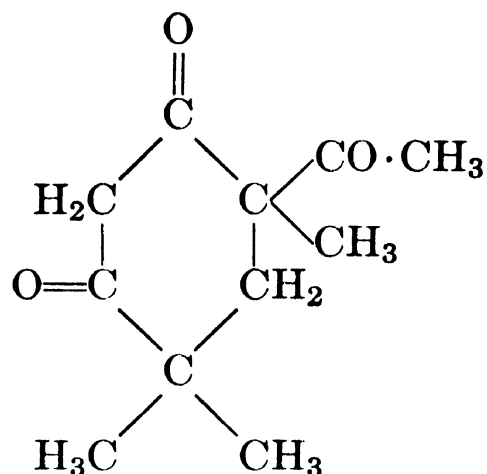

Occurrence and Isolation.—See above.

Identification.—Angustione can be characterized by the preparation of the following derivatives:

- (1) Anhydroangustione-4- or - ω -semicarbazone m. 145°.
- (2) Anhydroangustione-4- or -6-phenylhydrazone m. 119°–120°.
- (3) Anhydroangustione-4- or -6-*p*-bromophenylhydrazone m. 191°.
- (4) Anhydroangustione-4- or -6-oxime m. 41°–43°.
- (5) Piperonylidene-angustione m. 166°–167°.
- (6) On treatment with ferric chloride in dilute acetic acid, angustione yields 1,1,3-trimethylcyclo-hexene-2-dione-(4,6), $C_9H_{12}O_2$, m. 159°–160°.

Properties.—When purified through the amino compound $C_{11}H_{17}O_2N$, m. 130°–131°, or through the copper compound $C_{22}H_{30}O_6Cu$, m. 192°–193°, angustione had these properties:

b_{15}	129°	$[\alpha]_{5461}$	–5° 34'
d_{20}^{20}	1.089	n_D^{20}	1.5092

On treatment with ferric chloride, the alcoholic solution of angustione develops an intense orange-red color.

The synthetic *dl*-angustione has been prepared by hydrogenating dehydroangustione and likewise characterized by Simonsen and co-workers.⁵

The properties of the racemic form were quite similar to the natural isolate.

¹ *J. Proc. Roy. Soc. N. S. Wales* **57** (1923), 300.

² *J. Chem. Soc.* (1930), 1184.

³ *Ibid.* (1931), 286.

⁴ *J. Chem. Education* **9** (1932), 429.

⁵ *J. Chem. Soc.* (1931), 286.

Dehydroangustione

 $C_{11}H_{14}O_3$

Mol. Weight 194.22

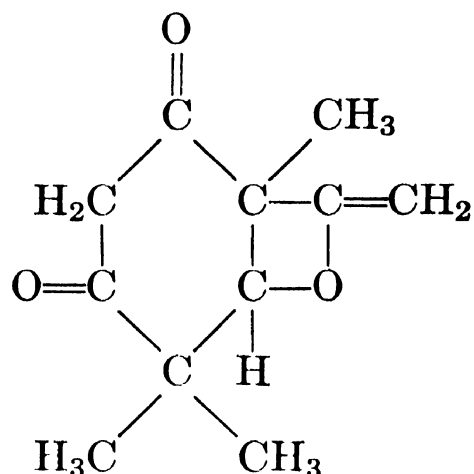

Occurrence and Isolation.—See above.

Identification.—Dehydroangustione can be characterized by the preparation of the following derivatives:

- (1) Aminodehydroangustione m. 151° .
- (2) α - and β -Anhydrodehydroangustione-4- or -6-semicarbazone m. 138° – 139° , and 173° – 175° .
- (3) Anhydrodehydroangustione-4- or -6-bromophenylhydrazone m. 247° – 248° .
- (4) Anhydrodehydroangustione-4- or -6-oxime m. 79° – 80° .
- (5) Piperonylidene-dehydroangustione m. 169° – 170° .

Properties.—When purified through its copper salt $C_{22}H_{26}O_6Cu$, m. 188° – 190° , dehydroangustione had these properties:

b_{11}	126° – 127°	$[\alpha]_{5461}$	$-2^\circ 2'$
$d_{20}^{20.5}$	1.103	$n_D^{20.5}$	1.5313

On treatment with ferric chloride, an alcoholic solution of dehydroangustione gives the same orange-red color as angustione.

Use.—Angustione and dehydroangustione are not used in our industries.

Jasmone

 $C_{11}H_{16}O$

Mol. Weight 164.24

3-Methyl-2-[2'-penten-yl]-2-cyclopenten-1-one

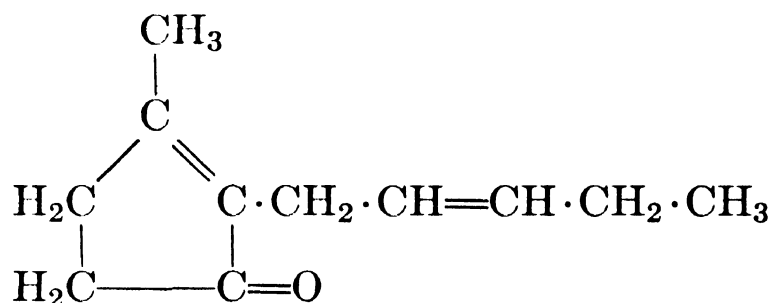

First described by Hesse,¹ the constitution of this ketone was later * elucidated by Ruzicka and Pfeiffer² and by Treff and Werner³ who also suc-

* In this connection, see *Parfumerie moderne* **28** (1934), 95 re: Scaled note of May 12, 1927, at Soc. Suisse de Chimie, Basel, by Soc. anon. M. Naef & Cie.

ceeded in synthesizing jasmone. It is the first monocyclic five-membered ring found in essential oils.

Occurrence.—The volatile oil of *Jasminum grandiflorum* contains about 3 per cent jasmone.

Isolation.—By fractional distillation *in vacuo* of ethereal jasmine oil, b_{6-7} 70°–120°, and by the preparation of the oxime or semicarbazone from the fraction b_{5-6} 108°–110° and regeneration of the parent ketone, by phthalic anhydride.

Identification.—Jasmone can be characterized by the preparation of:

(1) The oxime m. 45°.

(2) The semicarbazone m. 204°–206°, according to Treff and Werner,⁴ and 209.5°–210° according to Ruzicka and Pfeiffer.⁵

(3) Catalytic reduction gives dihydrojasmone b_{12} 120°, semicarbazone m. 175°–176°, and *p*-nitrophenylhydrazone m. 111°, according to Ruzicka and Pfeiffer,⁶ 106°–107° (LaForge and Haller⁷).

Properties.—Jasmone is a light-colored oil which darkens on standing. It has a characteristic jasmine-like odor. Ruzicka and Pfeiffer reported these properties for pure jasmone:

b_{775}	257°–258° (Hesse ⁸)	α_D	$\pm 0^\circ$
b_{12}	134°–135°	n_D^{23}	1.4979
d_4^{22}	0.9437		

Use.—Jasmone is almost indispensable for the compounding of jasmine scents but, since jasmone is hard to synthesize, more easily obtainable ketones of similar odor have lately been developed. Details will be found in the patent literature.⁹

¹ *Ber.* **32** (1899), 2617.

² *Helv. Chim. Acta* **16** (1933), 1208.

³ *Ber.* **66** (1933), 1521; **68B** (1935), 640.

⁴ *Ber.* **66** (1933), 1521.

⁵ *Helv. Chim. Acta* **16** (1933), 1210.

⁶ *Ibid.*

⁷ *J. Am. Chem. Soc.* **58** (1936), 1777.

⁸ *Ber.* **32** (1899), 2617.

⁹ Heine & Co., French Patent No. 767,725, July 24, 1934. Givaudan & Cie., Soc. anon. German Patent No. 639,455, Dec. 5, 1936. Haller & LaForge, U. S. Patent No. 2,096,715, Oct. 26, 1938.

SUGGESTED ADDITIONAL LITERATURE

H. Werner, "Constitution and Synthesis of Jasmone and Perfume Materials Resembling Jasmone and Their Use," *Fette u. Seifen* **45** (1938), 623. *Chem. Abstracts* **33** (1939), 1880.

Heinz Hunsdiecker and E. Wirth, "Synthesis of Jasmone," *Ber.* **75B** (1942), 460. *Chem. Abstracts* **37** (1943), 3404.

Everett L. Saul, "Jasmone—Constitution and History of Its Synthesis," *Am. Perfumer* **45**, No. 5 (1943), 27. *Chem. Abstracts* **37** (1943), 3881.

Leptospermone

(Formerly Leptospermol)

 $C_{15}H_{22}O_4$

Mol. Weight 266.33

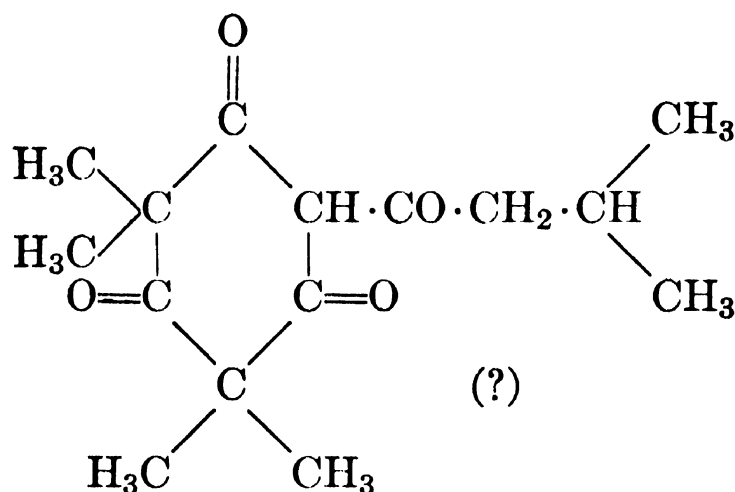

The compound $C_{14}H_{20}O_4$, formerly considered a phenol and called leptospermol, has been shown more recently, however, by Briggs, Penfold and Short¹ to be $C_{15}H_{22}O_4$ and actually a tetraketone possessing probably the structural formula pictured above. Briggs and collaborators, therefore, suggested changing the old designation leptospermol to leptospermone.

Occurrence.—In the oils distilled from various species of the genus *leptospermum*.

Isolation.—Leptospermone was isolated from these oils by extraction with a 4% aqueous sodium hydroxide solution and purified by washing with a saturated aqueous sodium bicarbonate solution, followed by distillation.

Identification.—(1) On boiling with aniline and zinc chloride, leptospermone gives anilino-leptospermone $C_{21}H_{27}O_3N$, m. 91° .

(2) On heating with phenylhydrazine for a half hour, leptospermone yields the anhydrophenylhydrazone $C_{21}H_{26}O_2N_2$, m. 118° .

(3) *p*-Toluidine and leptospermone yield the *p*-toluino derivative m. 101° , according to Briggs et al.²

Properties.—Briggs and collaborators³ reported the following properties of leptospermone:

b_{10}	146°	α_D	$\pm 0^\circ$
$d_4^{19.5}$	1.0688	$n_D^{19.5}$	1.5000

The ketone is a thick yellow liquid with a somewhat unpleasant odor.

Use.—Leptospermone, as such, is not used in our industries; it is, however, reported to possess anthelmintic activity.

¹ *J. Chem. Soc.* (1938), 1193.

² *Ibid.* (1945), 706.

³ *Ibid.* (1938), 1193.

H. LARGE RING KETONES

Muscone

 $C_{16}H_{30}O$

Mol. Weight 238.40

3-Methyl-1-cyclopentadecanone

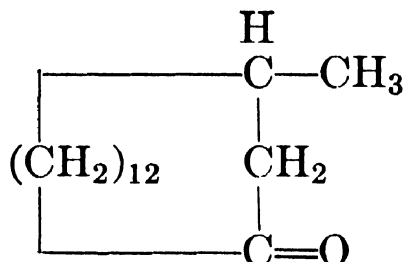

Occurrence.—Years ago Walbaum¹ recognized a ketone $C_{16}H_{30}O$ as the principal odoriferous component of the Chinese or tonquin musk. This musk is obtained from the dried secretion present in the musk sac located between the umbilicus and the preputial follicles of the male musk deer (*Moschus moschiferus* L.), a shy animal living in forests of the Himalaya Mountains from India to Siberia. The crude brown secretion occurs in quantities up to one ounce in the sac of the adult animal.

Ziegler and Weber,² Ruzicka and Stoll,³ Naef & Cie.,⁴ and Hunsdiecker⁵ succeeded in synthesizing racemic muscones while the natural *l*-rotatory muscone was described by Ruzicka,⁶ and by Ruzicka, Stoll, Huyser and Boekennoogen.⁷

Isolation.—The ether extract from the musk glands is saponified with 10% alcoholic potassium hydroxide and the neutral substances are fractionated by distillation. Crystallization of the semicarbazones and hydrolysis with aqueous oxalic acid solution concludes the isolation.

Identification.—The semicarbazone of the naturally occurring *l*-rotatory muscone melts at 134° , according to Ruzicka;⁸ after repeated recrystallization, at 140° – 141° , according to Ruzicka and Stoll.⁹

Ziegler and Weber¹⁰ reported for the semicarbazone of the racemic synthetic muscone a melting point of 133.5° – 134.5° , while Ruzicka and Stoll¹¹ found m. 136° – 137° , and 143° – 144° .

The phenylsemicarbazone of the natural *l*-rotatory muscone melts at 158° – 160° ; the same derivative of the synthetic racemic muscone melts at 170° – 171° , according to the last named authors.¹²

Properties.—Ruzicka and co-workers^{13,14} reported the following properties for the natural *l*-rotatory muscone:

$b_{0.5}$	130° ¹³	n_D^{17}	1.4802 ¹³
d_4^{110}	0.8647 ¹⁴	n_{HeI}^{104}	1.4496 ¹⁴
d_4^{18}	0.9212 ¹⁴	n_{HeI}^{72}	1.4606 ¹⁴
d_4^{17}	0.9221 ¹³	n_{HeI}^{18}	1.4797 ¹⁴
$[\alpha]_D$	$-13^\circ 1'$ ¹³		

The following properties have been reported by Ziegler and Weber,¹⁵ Hunsdiecker,¹⁶ and M. Naef & Cie.¹⁷ for synthetic racemic muscone:

$b_{1.2}$	128° ¹⁵	d_4^{20}	0.9193 ¹⁷
$b_{0.8}$	132° – 134° ¹⁶	n_D^{30}	1.4798 ¹⁷

Use.—Muscone is used as an odor modifier and fixative in high-grade perfumes.

- ¹ *J. prakt. Chem.* [2], **73** (1906), 480. *Ber. Schimmel & Co.* (1906), 98. German Patent No. 198,660.
² *Liebigs Ann.* **512** (1934), 164.
³ *Helv. Chim. Acta* **17** (1934), 1308.
⁴ French Patent No. 776,064, Jan. 16, 1935.
⁵ *Ber.* **75B** (1942), 1197.
⁶ *Helv. Chim. Acta* **9** (1925), 715.
⁷ *Ibid.* **13** (1930), 1152.
⁸ *Ibid.* **9** (1926), 715.
⁹ *Ibid.* **17** (1934), 1310.
¹⁰ *Liebigs Ann.* **512** (1934), 171.
¹¹ *Helv. Chim. Acta* **17** (1934), 1310, 1317.
¹² *Ibid.*
¹³ *Ibid.* **9** (1925), 715.
¹⁴ *Ibid.* **13** (1930), 1173.
¹⁵ *Liebigs Ann.* **512** (1934), 171.
¹⁶ *Ber.* **75B** (1942), 1201.
¹⁷ French Patent No. 776,064, Jan. 16, 1935.

SUGGESTED ADDITIONAL LITERATURE

L. Ruzicka, H. Schinz und M. Pfeiffer, "Zur Kenntnis des Kohlenstoffringes—Über die Herstellung methylierter 14-, 15- and 17-gliedriger cyclischer Ketone," *Helv. Chim. Acta* **11** (1928), 686.

R. W. Moncrieff, "The Biological Derivation of Civetone and Muscone," *Soap, Perfumery & Cosmetics* **20**, No. 3 (1947), 261.

M. Stoll and A. Rouvé, "Nouvelle Synthèse de la Muscone," *Helv. Chim. Acta* **30** (1947), 2019.

M. Stoll and A. Commarmont, "Transformation de la Cyclo-pentadécène-2-one-1 en Muscone," *Helv. Chim. Acta* **31** (1948), 554.

Civetone

$C_{17}H_{30}O$

Mol. Weight 250.41

9-Cycloheptadecenone

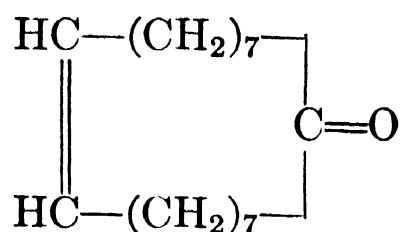

Occurrence.—Civetone is a very important constituent of civet, a glandular secretion obtained from a pouch located near the genitalia of both male and

female civet cats. These animals, *Vivirra civetta* and *Vivirra zibetha*, occur respectively in Africa and southern Asia. Most of the commercial product is gathered in Abyssinia. Sack¹ isolated from civet the odoriferous constituent, a ketone which is present in quantities of 2.5–3.5 per cent. Civetol and skatol, too, occur in civet.

Isolation.—According to Ruzicka,² the lipoids of the civet gland contents are hydrolyzed with 10% alcoholic potassium hydroxide. After fractionation, the small amount of semicarbazones of fraction b_{1.5} 130°–170° are recrystallized and decomposed with concentrated oxalic acid solution, yielding thereby civetone.

Identification.—Civetone can be identified by the preparation of derivatives:

- (1) Semicarbazone m. 190°–191° (Hunsdiecker³), m. 185°–186° (Ruzicka⁴).
- (2) *p*-Nitrophenylhydrazone m. 125°, decomposes in light (Ruzicka⁴).

Properties.—The following properties have been reported by Ruzicka⁴ for the natural civetone, and by Hunsdiecker⁵ for the synthetic product:

m.	37.5°–38.5° ⁵	d_4^{37}	0.9135 ⁴
m.	31° ⁴	α_D	±0° ⁴
b _{0.5}	145° ⁴	n_D^{37}	1.4820 ⁴

Reduction with platinum in alcohol yields cycloheptadecanone m. 64°–64.5°.

More recently Stoll, Hulstkamp and Rouvé⁶ succeeded in synthesizing natural civetone (isomer α) to which they ascribe the *cis* configuration, whereas the isomer β possesses the *trans* configuration. The latter can be converted into the *cis* form (natural civetone or civetone isomer α).

These authors reported the following properties:

<i>Civetone</i>	<i>Natural (cis)</i>	<i>Isomers</i>	
		α (<i>cis</i>)	β (<i>trans</i>)
m.	31°–32°	31°–32°	29°–30°
d_4^{33}	0.917	0.915	0.913
n_D^{33}	1.4830	1.4827	1.4812
<i>Semicarbazone</i>			
m.	186°–187°	186°–187°	195°–196°

Use.—Civetone is used in high-grade perfumes, to which it imparts a characteristic and lasting note.

¹ *Chem. Ztg.* **39** (1915), 538. German Patent No. 279,313 (1912).

² *Helv. Chim. Acta* **9** (1926), 230.

³ *Ber.* **76B** (1943), 142.

⁴ *Helv. Chim. Acta* **9** (1926), 239, 240.

⁵ *Ber.* **76B** (1943), 142.

⁶ *Helv. Chim. Acta.* **31** (1948), 543.

SUGGESTED ADDITIONAL LITERATURE

R. W. Moncrieff, "The Biological Derivation of Civetone and Muscone," *Soap, Perfumery & Cosmetics* **20**, No. 3 (1947), 261.

Eric Hardy, "Animals in Perfumery. I. The Civet," *Perfumery Essential Oil Record* **38**, No. 8 (1947), 276.

Dihydrocivetone

C₁₇H₃₂O

Mol. Weight 252.43

Cycloheptadecanone

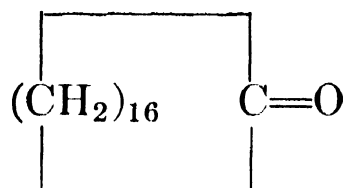

Occurrence.—According to Stevens and Erickson,¹ and Stevens,² dihydrocivetone occurs in the scent glands of the male and female Louisiana muskrat (*Ondatra zibethicus rivalicius*) and is accompanied by exaltone, cyclotridecanone and cyclonadecanone, these ketones amounting to about 2 per cent. The major part of the lipoids present in these glands, however, consists of dihydrocivetol (58 per cent) and normuscol (40 per cent). On oxidation with chromic acid these two alcohols form additional quantities of dihydrocivetone and exaltone.

Isolation.—Stevens and Erickson³ isolated dihydrocivetone by hydrolyzing the ether extract of the scent glands and by preparing the semicarbazone from the fraction b₁ 152°–155°.

Ruzicka, Stoll and Schinz⁴ synthesized dihydrocivetone by distilling the thorium salts of dicarboxylic acid, while Ziegler et al.⁵ obtained the synthetic product through the dinitriles under the influence of alkali metals.

Identification.—Stevens and Erickson⁶ prepared the following derivatives of naturally occurring dihydrocivetone:

- (1) Semicarbazone m. 190°–190.5°.
- (2) Oxime 63°–64°.
- (3) Iso-oxime 121.5°–123°.

Ruzicka et al.⁷ reported these derivatives of synthetic dihydrocivetone:

- (1) Semicarbazone m. 187°, m. 191°.
- (2) Oxime m. 63°.
- (3) Iso-oxime m. 123°–124°.
- (4) Benzaldehyde addition compound 113°–114°.

Properties.—According to Stevens and Erickson,⁸ naturally occurring dihydrocivetone has these properties:

m.	59°–61°
b ₁₁	189°
n _D ⁷⁰	1.4622

Ruzicka et al.,⁹ and Ziegler, Eberle and Ohlinger¹⁰ recorded the following properties for synthetic dihydrocivetone:

m.	63°–64° ⁹	n_D^{70}	1.4602 ⁹
$b_{0.3}$	145° ⁹	$n_{He_r}^{103}$	1.4492 ⁹
$b_{0.1}$	145° ¹⁰	$n_{He_r}^{72}$	1.4596 ⁹
d_4^{70}	0.8830 ⁹	$n_{He_1}^{72}$	1.4688 ⁹

Use.—Because of its musk-like odor, dihydrocivetone is used as an odor modifier and as a fixative in high-grade perfumes.

¹ *J. Am. Chem. Soc.* **64** (1942), 144.

² *Ibid.* **67** (1945), 907.

³ *Ibid.* **64** (1942), 144.

⁴ *Helv. Chim. Acta* **9** (1926), 249.

⁵ *Liebigs Ann.* **504** (1933), 94; **513** (1934), 43.

⁶ *J. Am. Chem. Soc.* **64** (1942), 144.

⁷ *Helv. Chim. Acta* **9** (1926), 230, 249.

⁸ *J. Am. Chem. Soc.* **64** (1942), 144.

⁹ *Helv. Chim. Acta* **9** (1926), 230, 249, 499; **13** (1930), 1152.

¹⁰ *Liebigs Ann.* **504** (1933), 94.

Exaltone

$C_{15}H_{28}O$

Mol. Weight 224.37

Normuscone. Cyclopentadecanone

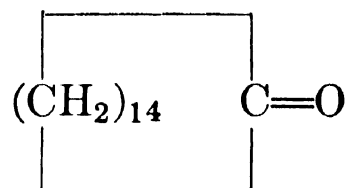

Occurrence.—Stevens and Erickson¹ identified exaltone in the scent glands of the Louisiana muskrat (*Ondatra zibethicus rivalicius*), where it occurs, together with dihydrocivetone, in the amount of about 2 per cent. The major part of this musk consists of dihydrocivetol (58 per cent) and normuscol (40 per cent).

Isolation.—By hydrolysis of the ether extract of the scent glands and preparation of the semicarbazone from the neutral fraction b_1 125°.

Identification.—Exaltone can be characterized by the preparation of derivatives:

(1) Semicarbazone m. 186°–187°, according to Stevens and Erickson; ² 187°–188°, according to Ruzicka, Stoll and Schinz.³

(2) 2,4-Dinitrophenylhydrazone m. 108°–109°, according to Stevens and Erickson.⁴

(3) *l*-Menthylhydrazone m. 138.5°–139.5°, by the same authors.⁵

Properties.—The following properties have been reported by Stevens and Erickson,⁶ for natural exaltone; and by Ruzicka, Stoll and Schinz,⁷ by Ziegler,

Eberle and Ohlinger,⁸ by Ruzicka, Stoll, Huyser and Boekenoogen,⁹ and by Ruzicka, Brugger, Pfeiffer, Schinz and Stoll¹⁰ for the synthetic exaltone:

m.	63°–65.5° ⁶	n_D^{66}	1.4637 ¹⁰
	63° ⁷	n_{HeI}^{102}	1.4510 ⁹
$b_{0.1}$	120° ⁸	n_{HeI}^{72}	1.4616 ⁹
d_4^{111}	0.8683 ⁹	n_{HeI}^{102}	1.4601 ⁹
$d_4^{76.5}$	0.8895 ⁹		
d_4^{66}	0.8973 ¹⁰		

Ruzicka, Stoll and Schinz¹¹ succeeded in synthesizing exaltone through distillation of the thorium salts of dicarboxylic acid, while Ziegler, Eberle and Ohlinger¹² achieved the same result by cyclization of dinitriles under the influence of alkali metal.

Oxidation of exaltone with persulfuric acid (Caro's acid) yields the corresponding musk lactone, viz., exaltolide.

Use.—Exaltone is used in high-grade perfumes. Because of its high cryoscopic constant, exaltone serves in analytical chemistry as a solvent for the determination of molecular weights.

¹ *J. Am. Chem. Soc.* **64** (1942), 144.

² *Ibid.*

³ *Helv. Chim. Acta* **9** (1926), 249.

⁴ *J. Am. Chem. Soc.* **64** (1942), 144.

⁵ *Ibid.*

⁶ *Ibid.*

⁷ *Helv. Chim. Acta* **9** (1926), 249.

⁸ *Liebigs Ann.* **504** (1933), 126.

⁹ *Helv. Chim. Acta* **13** (1930), 1172.

¹⁰ *Ibid.* **9** (1926), 499.

¹¹ *Ibid.* 249.

¹² *Liebigs Ann.* **504** (1933), 126.

I. KETONES OF DOUBTFUL CONSTITUTION

Santalone

$C_{11}H_{16}O$

Mol. Weight 164.24

The constitution of this ketone has not been established.

Occurrence.—In East Indian sandalwood oil, according to Müller,¹ and Schimmel & Co.²

Isolation.—By fractional distillation, preparation of the semicarbazone, and regeneration of the ketone.

Identification.—Santalone can be characterized by the preparation:

- (1) Of a semicarbazone m. 174°–176°.
- (2) Of an oxime m. 74.5°–75.5°.

Properties.—The following properties have been reported by the aforementioned authors:

b.	214°–215° ¹	α_D	–62° 0' ¹
b.	213°–216° ²	α_D	–41° 32' ²
b ₁₅	88°–89° ¹	n _D ²⁰	1.50021 ²
d ₁₅ ¹⁵	0.9909 ²		
d ₁₅	0.9906 ¹		

Use.—Santalone as such is not used in our industry.

¹ *Arch. Pharm.* **238** (1900), 366, 373.

² *Ber. Schimmel & Co.*, Oct. (1910), 105.

Parmone

C₁₃H₂₀O

Mol. Weight 192.29

Parmone is isomeric with the ionones. Its structural formula has not yet been definitely established.

Occurrence.—According to Ruzicka,¹ parmone occurs in the absolute oil of violet flowers, but not in the oil derived from violet leaves.

Isolation.—Ruzicka and Schinz² treated the fraction b₁₂ 80°–100° ($\alpha_D + 5^\circ 54'$, d₂₀ 0.924), of an oil derived by double steam distillation of a Victoria violet flower extract, with semicarbazide, decomposed the semicarbazone with aqueous oxalic acid, and steam distilled the ketones. On treating the distillate with Girard reagent T, a fraction rich in parmone was obtained: b₁₂ 110°–120°.

Identification.—Parmone can be identified through the preparation of its phenylsemicarbazone m. 166°–168°, and of the *p*-bromophenylhydrazone m. 132°–133°.

Properties.—The odor of parmone in dilution is more nearly like that of violet flowers than is the odor of the ionones, methyl ionones, or irone.

b₁₂ 110°–120°

Use.—Natural parmone as isolated from violet flowers is not used in our industries, nor have any reports on its synthesis yet reached the literature.

¹ *Compt. rend. 17th Congr. chim. ind., Paris*, Sept.-Oct. (1937), 915. *Chem. Abstracts* **32** (1938), 6805.

² *Helv. Chim. Acta* **25** (1942), 765, 773.

V. PHENOLS AND PHENOL ETHERS

Introduction.—Phenols and phenol ethers belong among the most important constituents of volatile oils. Some oils—for example, thyme and origanum—owe their value in the pharmaceutical field almost entirely to the antiseptic and germicidal properties of their phenolic content. Others are most popular flavoring ingredients—for instance, oil of clove, anise, estragon, saffras, etc. Most phenols and phenol ethers possess a powerful aromatic odor and flavor.

The phenols form water soluble salts in dilute (3 to 5 per cent) alkali solution, which property offers a convenient method for the separation of phenols from nonphenolic constituents. For this purpose the volatile oils, or fractions, are shaken with dilute aqueous alkaline solutions, the two layers separated, the water soluble salts decomposed by acidification, and the regenerated phenols isolated by steam distillation or ether extraction. Thymol and carvacrol can be steam distilled from the alkaline solution without previous acidification. Details will be found in the special part. Several phenols and phenol ethers can be isolated by cooling the oil, or the proper fraction, to a low temperature whereby these compounds separate in crystalline form.

p-Isopropylphenol

$C_9H_{12}O$

(Australol)

Mol. Weight 136.19

1-Hydroxy-4-isopropylbenzene. *p*-Hydroxycumene. *p*-Cumenol

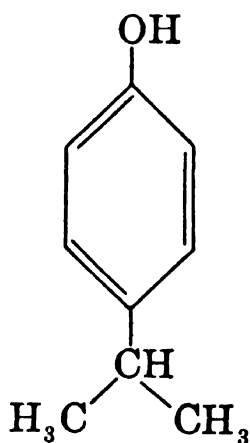

Occurrence.—Investigating the composition of oil of *Eucalyptus polybractea* R. T. Baker, which formerly was believed to contain a new phenol called australol, Earl and Trikojus¹ found that in reality australol is identical with *p*-isopropylphenol. Penfold² isolated this compound from oil of *Eucalyptus Bakeri* Maiden.

Isolation.—By the formation of a water-soluble salt in an aqueous alkali solution and regeneration by acidification, etc.

According to Vavon and Zaharia,³ *p*-isopropylphenol can be isolated from an alkaline solution by extracting the latter with ether.

Identification.—By preparation of its benzoate m. 71° (Huston et al.⁴), m. 71.5° (Earl and Trikojus⁵), and m. 73°–74° (Penfold⁶).

Properties.—Penfold,⁷ Earl and Trikojus,⁸ Bert,⁹ von Braun,¹⁰ Vavon and Callier,¹¹ and Huston et al.¹² reported these properties of *p*-isopropylphenol:

m.	62°–63° (leaflets from petroleum ether) ⁷
m.	60° ⁸
b.	228° ⁹
b ₇₄₅	228°–229° ¹²
b ₁₉	119° ⁹
b ₁₂	112°–115° ¹⁰
b ₁₀	109°–111° ¹¹

Use.—*p*-Isopropylphenol, as such, is used very little in the perfume and flavor industries.

¹ *J. Proc. Roy. Soc. N. S. Wales* **59** (1925), 301. Cf. Robinson and Smith, *ibid.* **48** (1914), 518.

² *Ibid.* **61** (1927), 180.

³ *Compt. rend.* **187** (1928), 347.

⁴ *J. Am. Chem. Soc.* **67** (1945), 899.

⁵ *J. Proc. Roy. Soc. N. S. Wales* **59** (1925), 301.

⁶ *Ibid.* **61** (1927), 180.

⁷ *Ibid.*

⁸ *Ibid.* **59** (1926), 301.

⁹ *Compt. rend.* **177** (1923), 453. *Bull. soc. chim.* [4], **37** (1925), 1252, 1398.

¹⁰ *Liebigs Ann.* **472** (1929), 65.

¹¹ *Bull. soc. chim.* [4], **41** (1927), 678.

¹² *J. Am. Chem. Soc.* **67** (1945), 899.

Thymol

C₁₀H₁₄O

Mol. Weight 150.21

3-Hydroxy-*p*-cymene. 3-Methyl-6-isopropylphenol. "Thyme Camphor"

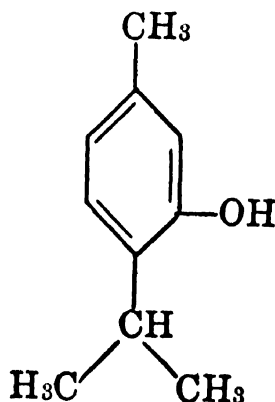

Occurrence.—Thymol is the main constituent of several important oils belonging to the *Labiatae* family, for example, oil of thyme (*Thymus vulgaris*) and ajowan; it also occurs in oils derived from several species of *Ocimum*,

such as *O. gratissimum* and *O. viride*; furthermore in oil of *Monarda punctata*, etc. For details see Albers,¹ "The Occurrence of Thymol and Carvacrol in the Plant Kingdom and Their Significance in Botanical Systematics." Occasionally thymol crystallizes from these oils at ordinary temperature. Frequently thymol in essential oils is accompanied by carvacrol.

Isolation.—Thymol can be isolated from volatile oils:

(1) By crystallization at low temperature.

(2) By fractional distillation.

(3) By the preparation of water soluble salt in dilute aqueous alkali solution from which the thymol can be regenerated by extraction with ether or by steam distillation. (Compare with "Carvacrol.")

Identification.—Thymol can be characterized by several methods:

(1) By the preparation of derivatives:

(a) Phenylurethane m. 106°–107°, according to Weehuizen.²

(b) α -Naphthylurethane m. 160°, according to French and Wirtel.³

(c) *p*-Bromobenzene sulfonate m. 103.5°, by Sekera.⁴

(d) 3,5-Dinitrobenzoate m. 103.2°, by Phillips and Keenan.⁵

(e) *p*-Iodophenylurethane m. 175°–176°, by Sah and Young.⁶

(f) By coupling with diazotized *p*-nitroaniline and subsequent chromatographic separation of the derived dyes it is possible to identify thymol in a mixture of several hydroxy benzenes, according to Bielenberg and Fischer.⁷

(2) By oxidation:

Using potassium bichromate and sulfuric acid, Bargellini⁸ oxidized thymol, or its nitroso and amino compounds, to thymoquinone m. 44°–46°. Cohn and Richter⁹ mentioned also the use of magnesium dioxide for the preparation of thymoquinone from thymol.

(3) By color reactions:

When fused with phthalic anhydride, thymol develops a strongly violet-red to red color, and in dilute alkaline solution an intense blue color (thymolphthalein).

When treated with ferric chloride, an alcoholic solution of thymol, contrary to carvacrol, does not show any color reaction, but when dissolved in concentrated sulfuric acid, thymol forms thymol sulfonic acid $C_6H_2(SO_3H) \cdot (CH_3) \cdot (C_3H_7) \cdot (OH)$, the latter, according to Gildemeister and Hoffmann,¹⁰ producing a violet color with ferric chloride.

The U.S.P. XIII (p. 574) suggests the two following color reactions:

Dissolve a very small crystal of thymol in 1 cc. of glacial acetic acid, add 6 drops of sulfuric acid and 1 drop of nitric acid: the liquid shows a deep bluish-green color when viewed by reflected light.

Heat about 1 g. of thymol in a test tube in a water bath with 5 cc. of a 10 per cent solution of sodium hydroxide: a clear, colorless, or pale red solution is formed, which becomes darker on standing, without the separation of oily drops. Upon the addition of a few drops of chloroform to this solution and agitating the mixture, a violet color is produced.

Quantitative Determination.—Like all phenols, thymol forms water soluble salts in dilute (5–10 per cent) aqueous solutions of alkalis, which property is used for the quantitative determination of thymol. See Vol. I, Chapter 4, "Examination and Analysis of Essential Oils, Synthetics, and Isolates," p. 291.

Properties.—Thymol forms transparent colorless monoclinic or hexagonal crystals. Its odor is reminiscent of thyme. Thymol crystals sink in water and therefore have a specific gravity above 1.0. In liquid phase, however, this phenol floats on the surface of water. Thymol can be undercooled considerably below its melting point without solidifying (cf. Meyer and Pfaff¹¹). The following properties have been reported by Gildemeister and Hoffmann,¹² Meyer and Pfaff,¹³ Perkin,¹⁴ and Nasini and Bernheimer:¹⁵

cong. pt.	49°–50° ¹²	$d_4^{24.4}$	0.9689 ¹⁵
m.	50°–51.5° ¹²	d_{20}^{20}	0.9757 ¹⁴ (undercooled)
	51° ¹³	d_{15}^{15}	0.9790 ¹⁴ (undercooled) ¹⁶
b.	233.5° ¹⁴ (corr.)	$n_D^{24.4}$	1.51893 ¹⁵
b _{749–752}	233°–234° ¹²	n_D^{20}	1.52269 ¹² (undercooled)

Thymol is only sparingly soluble in water (1:1200) and in glycerol (1:1000), better in paraffin oil (1:20), and readily soluble in alcohol, ether, chloroform, benzene, or glacial acetic acid. It is soluble in volatile and fatty oils, and volatile with steam.

Active carbon has been observed to exert a catalytic effect upon thymol and should be used cautiously in connection with decolorization procedures (cf. Kimura¹⁷).

Use.—Thymol was originally introduced as a disinfectant in lieu of carbolic acid, having the advantage of a more pleasant odor. Thymol, however, has the drawbacks of producing a strong local irritant effect and of being only sparingly soluble in water. In the absence of large amounts of organic matter, thymol seems to possess considerably more powerful antibacterial properties than carbolic acid. Thymol is employed in many of the antiseptic mixtures intended for use upon mucous cavities, especially in gargles, mouth washes, other oral preparations, and as a local anesthetic in toothache. Because of its strong local irritant action, thymol cannot be applied, without some discomfort, in stronger solutions than 1 part in 1,000. Thymol is also used as a gastro-intestinal disinfectant in fermentative gastritis, enteritis, and similar cases.

Another important use of thymol is as a vermifuge against tapeworm and probably all forms of intestinal parasites, especially the hookworm. For this purpose thymol must be applied in such large doses that there exists danger of poisoning unless absorption is guarded against.

Thymol is furthermore used for the compounding of synthetic essential oils; it also serves as a starting material for the making of synthetic menthol.

¹ *Pharm. Arch.* **13**, May (1942).

² *Rec. trav. chim.* **37** (1918), 268.

³ *J. Am. Chem. Soc.* **48** (1926), 1738.

- ⁴ *Ibid.* **55** (1933), 421.
⁵ *Ibid.* **53** (1931), 1926.
⁶ *Rec. trav. chim.* **59** (1940), 357.
⁷ *Brennstoff-Chem.* **22** (1941), 278.
⁸ *Gazz. chim. ital.* **53** (1923), 238.
⁹ "Die Riechstoffe," 2d Ed., 116.
¹⁰ "Die Ätherischen Öle," 3d Ed., Vol. I, 598.
¹¹ *Z. anorg. Chem.* **217** (1934), 257.
¹² "Die Ätherischen Öle," 3d Ed., Vol. I, 597.
¹³ *Z. anorg. Chem.* **217** (1934), 257.
¹⁴ *J. Chem. Soc.* **69** (1896), 1183.
¹⁵ *Gazz. chim. ital.* **15** (1885), 84. *Jahresber. Chem.* (1885), 314.
¹⁶ Cf. Pardee and Weinrich, re: calculated value of d for liquid at 60° F/4°C., *Ind. Eng. Chem.* **36** (1944), 603.
¹⁷ *Bull. Chem. Soc. Japan* **10** (1935), 330.

Carvacrol

C₁₀H₁₄O

Mol. Weight 150.21

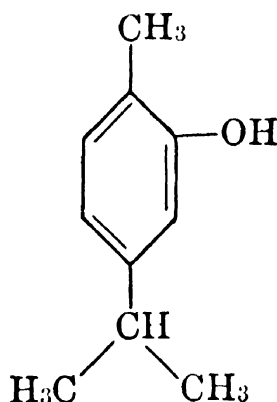
2-Hydroxy-*p*-cymene. 2-Methyl-5-isopropylphenol

Occurrence.—Carvacrol forms the main constituent of several important volatile oils derived from various species of the *Labiatae* family, particularly Spanish, Moroccan and Syrian oil of origanum (*Coridothymus capitatus* syn. *Thymus capitatus*), also oil of savory, marjoram, *Monarda punctata*, *Pycnanthemum lanceolatum*, etc. In many other oils carvacrol occurs as a minor constituent. For details, see Albers,¹ "The Occurrence of Thymol and Carvacrol in the Plant Kingdom and Their Significance in Botanical Systematics."

Isolation.—In aqueous alkali solutions, carvacrol forms a water soluble salt from which this phenol can be regenerated by extraction with ether or by steam distillation.

Identification.—Carvacrol may be characterized by several methods:

(1) By the preparation of derivatives:

(a) Phenylurethane m. 134°–135°, according to Weehuizen,² and Goldschmidt.³

(b) α -Naphthylurethane m. 116°, according to French and Wirtel.⁴

(c) Substituted phenylurethanes, by Sah and Young:⁵

<i>p</i> -iodo	m. 135°–136°
<i>p</i> -bromo	m. 136°–137°
<i>p</i> -nitro	m. 143°

(2) By color reactions:

With ferric chloride but in a very concentrated alcoholic solution, carvacrol develops a fugitive green color,—a means of distinguishing carvacrol from thymol.

Bielenberg and Fischer ⁶ recommended the coupling of *p*-nitroaniline with the sodium salt and chromatographic separation of the dye from other hydroxy benzenes as a means of identifying carvacrol in the presence of several phenols.

Puxeddu ⁷ had earlier used a modification of this technique for the same purpose. This author suggested that the sodium hydroxide extract be coupled with diazonium chloride and the colored hydroxy azo derivative purified by crystallization. The hydroxy azo compound is decomposed with phenylhydrazine and the amino phenol purified.

(3) By oxidation:

Dissolving carvacrol in concentrated sulfuric acid, and diluting and oxidizing the phenol with manganese dioxide, Carstanjen ⁸ obtained yellow plates of thymoquinone m. 45.5°. Claus and Fahrion ⁹ used potassium permanganate for the oxidation, whereas Reychler ¹⁰ applied potassium chromate for the preparation of the same product. Thymoquinone is volatile with steam.

(4) According to Jacobsen,¹¹ carvacrol on prolonged gentle warming with potassium hydroxide is converted into isohydroxycuminic acid $(\text{CH}_3)_2\text{CH}\cdot\text{C}_6\text{H}_3(\text{OH})\text{COOH}$, which volatilizes with steam and melts at 93°.

Properties.—When freshly distilled, carvacrol is a colorless, somewhat viscid liquid which darkens on exposure to air and light. Carvacrol can be cooled considerably below its melting point before it solidifies.

The following properties have been reported by Gildemeister,¹² John and Beetz,¹³ Dzirkal,¹⁴ Semmler,¹⁵ and Gildemeister and Hoffmann:¹⁶

m.	1° ¹³	d_4^{20}	0.9772 ¹⁴
b.	237.5° ¹³	d_4^{20}	0.976 ¹² (from origanum oil)
	236.8°–237.4° ¹⁴	d_{15}	0.980 ¹² (from origanum oil)
b ₇₄₂	235.5°–236.2° ¹² (from origanum oil)	n_D^{20}	1.52338 ¹² (from origanum oil)
b ₁₆	119° ¹⁵	Sol.	Soluble in 2–3 vol. of 70% alcohol ¹⁶

Carvacrol, like thymol, is volatile with steam, even from strongly alkaline solutions, a property not shared by other phenols, except thymol. It is soluble in concentrated sulfuric acid with sulfonation, sparingly soluble in water, and readily soluble in alcohol or ether. Soluble in alkalis with formation of a water soluble salt from which carvacrol, like thymol, can be extracted with ether. Stoermer and Kippe ¹⁷ reported that in strong alkali—for example, in a 30–40 per cent aqueous sodium hydroxide solution—the sodium compound of carvacrol goes into the ether layer, while thymol under the same condition dissolves as pure phenol in the ether layer. Sherk ¹⁸ found that, from a dilute (5 per cent) aqueous sodium hydroxide solution, either carvacrol or thymol can be regenerated as pure phenols by ether extraction of the alkaline solution.

According to Hubacher,¹⁹ carvacrol phthalein m. 293.5°–294.7° (corr.) turns from colorless to blue at a pH 9.5 to 10.5, and in concentrated sulfuric acid purple red.

Brunel,²⁰ and Paolini²¹ found that, on hydrogenation with a nickel catalyst, according to Sabatier and Senderens, carvacrol yields a mixture of two isomeric alcohols, viz., α - and β -carvacromenthol, the latter on oxidation with chromic acid forming *i*-tetrahydrocarvone.

Use.—Like thymol, carvacrol is used widely as a powerful antiseptic and germicide in all kinds of medicinal and oral preparations, disinfectants, room sprays, etc. It has been suggested as a local anesthetic in toothache and as an anthelmintic.

Carvacrol furthermore finds application in the scenting of soaps and in the compounding of imitation or artificial essential oils.

- ¹ *Pharm. Arch.* **13**, May (1942).
² *Rec. trav. chim.* **37** (1918), 356.
³ *Ber.* **26** (1893), 2086.
⁴ *J. Am. Chem. Soc.* **48** (1926), 1738.
⁵ *Rec. trav. chim.* **59** (1940), 357.
⁶ *Brenstoff-Chem.* **22** (1941), 278.
⁷ *Ann. chim. applicata* **16** (1926), 323.
⁸ *J. prakt. Chem.* II, **15** (1877), 410.
⁹ *Ibid.* II, **39** (1889), 360.
¹⁰ *Bull. soc. chim.* III, **7** (1892), 34. *Chem. Zentr.* I (1892), 380.
¹¹ *Ber.* **11** (1878), 573, 1061.
¹² *Arch. Pharm.* **233** (1895), 188.
¹³ *J. prakt. Chem.* II, **143** (1935), 256.
¹⁴ *Trans. Inst. Pure Chem. Reagents U.S.S.R.*, No. 17 (1939), 40. *Chem. Abstracts* **36** (1942), 2257.
¹⁵ *Ber.* **25** (1892), 3353.
¹⁶ "Die Ätherischen Öle," 3d Ed., Vol. I, 600.
¹⁷ *Ber.* **36** (1903), 3992.
¹⁸ *Am. J. Pharm.* **93** (1921), 8.
¹⁹ *J. Am. Chem. Soc.* **64** (1942), 2538. *Chem. Abstracts* **37** (1943), 629.
²⁰ *Compt. rend.* **145** (1907), 1427.
²¹ *Gazz. chim. ital.* **55** (1925), 812. *Chem. Zentr.* I (1926), 3599.

Chavicol

C₉H₁₀O

Mol. Weight 134.17

p-Allylphenol. 1-Hydroxy-4-allylbenzene. *p*-Hydroxyallylbenzene

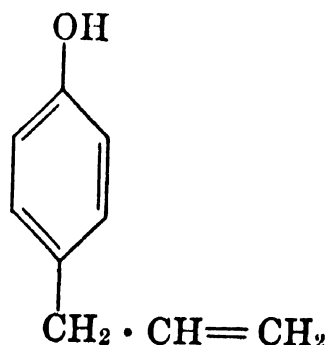

Occurrence.—Chavicol occurs in oil of bay, in some oils of betel leaf, and in a few other volatile oils. Zemplén¹ identified natural lusitanicoside as chavicol- β -rutinoside.

Isolation.—(1) By the preparation of water soluble salts in alkali solution and regeneration through acidification, etc. In order to isolate chavicol from volatile oils—betel leaf oil, for example—the phenols are first extracted with dilute aqueous alkali, and the freed crude phenols fractionated, the fraction b. 235°–240° containing the chavicol.

(2) Palkin and Wells ² found the most satisfactory procedure for the preparation of a pure grade of chavicol from oil of bay to be the separation of the sodium phenolate with 5% aqueous sodium hydroxide. This solution is well cooled and the phenol freed by 10% sulfuric acid. The phenol is separated by centrifuging and fractionated in a 32 plate column at 7 mm. to remove the eugenol. The fraction b₇ 103.2°–103.6° contains most of the chavicol. Finally crystallize the chavicol by cooling.

Identification.—Chavicol can be characterized as follows:

(1) Chavicol 3,5-dinitrobenzoyl ester was prepared by the action of 3,5-dinitrobenzoyl chloride upon the phenol in pyridine. According to Palkin and Wells ³ it melts at 103.5°–104.5°.

(2) On treatment with ferric chloride, an aqueous solution of chavicol gives a pronounced blue color, whereas an alcoholic solution develops only a faint blue shade.

Properties.—The following properties have been reported by Palkin and Wells: ⁴

m.	16°	$d_4^{15.5}$	1.0203
b.	235°–236°	n_D^{20}	1.5448

Chavicol is sparingly soluble in water and soluble in organic solvents.

Use.—Because of its strongly antiseptic properties, chavicol is useful medically.

¹ *Math. naturw. Anz. ungar. Akad. Wiss.* **56** (1937), 560. *Chem. Abstracts* **32** (1938), 2136.

² *J. Am. Chem. Soc.* **55** (1933), 1557.

³ *Ibid.*

⁴ *Ibid.*

Methyl Chavicol

C₁₀H₁₂O

Mol. Weight 148.20

Chavicol methyl ether. *p*-Allylanisole. *p*-Methoxyallylbenzene. Estragole *

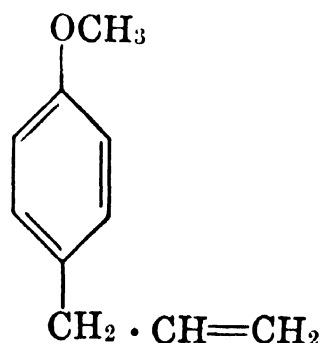

Occurrence.—Methyl chavicol occurs in American wood turpentine oil, in oil of estragon, star anise, anise, fennel, bay, in German, French and Japanese oils of basil. Herissey ¹ reported it in the glucoside, lusitanicoside. Goto ²

* Synonymous with "Esdragol."

identified it in the steam distilled oil of the fruit and leaves of Manchurian *Fagara mantshurica* Honda.

Isolation.—By fractional distillation.

Hasselstrom and Hampton ³ found that this compound could be isolated successfully from turpentine by shaking an ether solution of b_{10} 88°–95° with aqueous mercuric acetate and heating the aqueous solution with sodium hydroxide and zinc.

This technique is also useful, according to Balbiano,⁴ to separate methyl chavicol from anethole.

Identification.—Methyl chavicol can be characterized by several methods:

(1) On boiling with alcoholic potassium hydroxide or on heating with sodium ethylate under pressure, methyl chavicol, according to Gildemeister and Hoffmann,⁵ is converted into anethole m. 21°. Vinogradova and Novotel'nova ⁶ obtained anethole by heating 2 parts of solid potassium hydroxide with 1 part of methyl chavicol for 2 hr. at 130°.

(2) Oxidizing methyl chavicol with dilute potassium permanganate, Bertram and Walbaum ⁷ obtained homoanisic acid (*p*-methoxyphenylacetic acid) m. 84°–85° and, in addition, a little *p*-anisic acid m. 184°. The latter acid, however, may also have been formed by oxidation of anethole.

(3) By the preparation of monobromomethylchavicol dibromide m. 62.4°, according to Hell and Gaab,⁸ and Goto.⁹

Properties.—Methyl chavicol is a colorless liquid possessing an odor slightly reminiscent of anise; its flavor is not as intensely sweet as that of anethole. The following properties have been reported by Hasselstrom and Hampton,¹⁰ Gildemeister and Hoffmann,¹¹ Eykman,¹² and Lobo:¹³

b.	213°–215° ^{10, 13}	n_D^{22}	1.51372 ¹⁰
b_{12}	97°–97.5° ¹¹	n_D^{16}	1.52355–1.52380 ¹¹
b_7	86° ¹¹	$n_D^{11.5}$	1.5244 ¹²
d_{25}^{25}	0.9600 ¹⁰		
d_{15}^{15}	0.9714–0.972 ¹¹		

Use.—Methyl chavicol is used for the compounding of certain synthetic essential oils, estragon, for instance.

¹ *Compt. rend.* **198** (1934), 265.

² *J. Pharm. Soc. Japan* **61** (1941), 91. *Chem. Abstracts* **35** (1941), 7971.

³ *J. Am. Chem. Soc.* **60** (1938), 3086.

⁴ *Ber.* **42** (1909), 1504.

⁵ "Die Ätherischen Öle," 3d Ed., Vol. I, 603.

⁶ *Trudy Vsesoyuz. Inst. Efirno-Maslichnoĭ Prom.* **8** (1940), 141. *Chem. Abstracts* **37** (1943), 3558.

⁷ *Arch. Pharm.* **235** (1897), 179, 182. Cf. Goto, *J. Pharm. Soc. Japan* **61** (1941), 91. *Chem. Abstracts* **35** (1941), 7971.

⁸ *Ber.* **29** (1896), 344.

⁹ *J. Pharm. Soc. Japan* **61** (1941), 91. *Chem. Abstracts* **35** (1941), 7971.

¹⁰ *J. Am. Chem. Soc.* **60** (1938), 3086.

¹¹ "Die Ätherischen Öle," 3d Ed., Vol. I, 603.

¹² *Ber.* **23** (1890), 862.

¹³ *Ion* **3** (1943), 410. *Chem. Abstracts* **38** (1944), 1319.

SUGGESTED ADDITIONAL LITERATURE

J. M. v. d. Zanden, "Polymers of Methyl Chavicol," *Proc. Acad. Sci. Amsterdam* **40** (1937), 706. *Chem. Abstracts* **32** (1938), 1676. Also *Rec. trav. chim.* **57** (1938), 233. *Chem. Abstracts* **32** (1938), 4965.

T. I. Knishevetskaya, "The Composition of the Essential Oils of Hybrids of Basil," *Trudy Gosudarst. Nikitskogo Botan. Sada* **21**, No. 2 (1939), 29. *Khim. Referat. Zhur.* No. 6 (1940), 128. *Chem. Abstracts* **36** (1942), 5207.

L. Bert, "Synthesis of Allyl and Propenyl Essential Oils. General Method," *Compt. rend.* **213** (1941), 873. *Chem. Abstracts* **37** (1943), 4060.

J. M. v. d. Zanden, M. G. de Vries and P. Westerhof, "Polymerization of Methyl Chavicol and Ethyl Chavicol. 1,6-Dianisyl-1,5-Hexadiene and 1,6-Diphenylethyl-1,5-Hexadiene," *Rec. trav. chim.* **62** (1943), 283. *Chem. Abstracts* **38** (1944), 2329.

Ollivier Gaudin and Noël Lazac'h, "Sulfurized Derivatives of Anethole and Estragole," *Compt. rend.* **224** (1947), 577. *Chem. Abstracts* **41** (1947), 3441.

Anethole

C₁₀H₁₂O

Mol. Weight 148.20

p-Propenylanisole. *p*-Methoxypropenylbenzene. "Anise camphor"

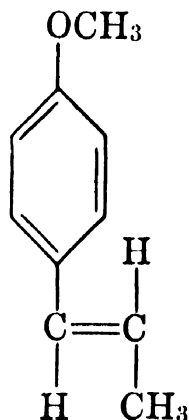

Occurrence.—Anethole is the main constituent of several volatile oils derived from the seed of plant species belonging to the family *Umbelliferae*, viz., anise and fennel. It also forms the principal constituent of star anise oil (*Illicium verum*) and occurs in several other essential oils.

Isolation.—Anethole is most conveniently isolated from volatile oils by first fractionating the oil, by cooling the corresponding fraction to a low temperature, and by recrystallization. From some oils which contain a high percentage of anethole, this phenol ether can be isolated directly by cooling.

Identification.—Anethole may be characterized by several methods:

(1) By the preparation of 2-monobromoanethole dibromide $\text{CH}_3\text{O} \cdot \text{C}_6\text{H}_3\text{Br} \cdot \text{C}_3\text{H}_5\text{Br}_2$. Underwood, Baril and Toone¹ developed the following procedure:

Dissolve 0.37 g. of anethole in 4 cc. of absolute ether cooled in ice. In the course of 8 min. add drop by drop 0.84 g. of bromine (2 mols) dissolved in 3 cc. of absolute ether. Evaporate the ether. Grind the solid residue in a mortar with 1 cc. of alcohol and recrystallize from 18 cc. of petroleum ether. Yield 0.68 g. of needles m. 107.6°–108°, which melting point has been determined as 102° by Orndorff and Morton,² and as 107°–108° by Hell et al.³

(2) Oxidizing anethole with potassium permanganate, King and Murch ⁴ obtained (92% yield) *p*-methoxybenzoic acid (*p*-anisic acid) m. 184°, but with alkaline potassium permanganate both anisic acid and anisaldehyde were formed. Gildemeister and Hoffmann ⁵ reported that oxidation of anethole with chromic acid yields anisaldehyde and anisic acid, while oxidation with potassium permanganate gives 4-methoxyphenylglyoxylic acid $\text{CH}_3\text{O}\cdot\text{C}_6\text{H}_4\cdot\text{CO}\cdot\text{COOH}$, m. 89°, the oxime of which melts at 145°–146°. Oxidizing anethole with 3.5 parts of dilute nitric acid and 2 parts of glacial acetic acid for one half hour, Labbé ⁶ obtained anisaldehyde, a fact confirmed by Shoesmith.⁷ Oxidizing anethole with ozone, Briner and Nemitz ⁸ also obtained anisic aldehyde.

(3) By the preparation of nitroso derivatives.

Kramli and Bruckner ⁹ treated a solution of anethole in ether with aqueous sodium nitrite acidified with sulfuric acid and obtained anethole- ψ -nitrosite m. 126° (decomposition). It seems obvious that a lower melting unstable form for this molecule exists; its presence may be anticipated and care maintained in purification so as to obtain a maximum melting point. Wallach and Müller ¹⁰ prepared the nitrosochloride m. 127°–128°; Perrot ¹¹ reported the nitropiperidine m. 90°.

(4) Condensation product of anethole and maleic anhydride, m. 310°; 1,2,3,8-tetrahydro-7-methoxy-3-methyl-1,2-naphthalenedicarboxylic acid as derived therefrom, m. 292°. Oxidation of the condensation product yields anisic acid (Tamayo and Ayestaran ¹²). Conditions influence the direction of condensation of this molecule (cf. Hudson and Robinson ¹³). To obtain the naphthalenedicarboxylic acid mentioned above, therefore, it is recommended that 14.8 g. of anethole and 19.6 g. of maleic anhydride be heated under reflux for 12 hr. in 200 cc. of toluene. Wash thoroughly with alcohol, hydrolyze by solution in hot 2 *N* sodium hydroxide, and precipitate with hydrochloric acid.

Properties.—Anethole is a white crystalline mass of intensely sweet odor and taste, characteristic of anise seed. It melts to a colorless, highly refractive liquid. The following properties have been reported by Gildemeister and Hoffmann,¹⁴ Stohmann,¹⁵ Sanderson and Jones,¹⁶ Block,¹⁷ Jourdan,¹⁸ Eykman,¹⁹ and Lobo:²⁰

cong. pt.	21°–22° ¹⁴	d_{25}	0.986 ¹⁵
	21°–22° ¹⁸ (from oil of star anise)		0.984–0.986 ¹⁴
		$d_{11.5}$	0.999 ¹⁹
	21.3° ^{16, 20}	n_D^{25}	1.559–1.561 ¹⁴
m.	22.5°–23° ¹⁴	n_D^{18}	1.56149 ¹⁵
	22.32° ¹⁷	$n_D^{11.5}$	1.5624 ¹⁹
b.	232°–234° ²⁰	Sol.	Soluble in 2–3 vol. of
b ₇₅₁	233°–234° ¹⁴		90% alcohol ¹⁴

Anethole is almost insoluble in water, but miscible in all proportions with organic solvents.

Under the influence of light and air, or heat, anethole loses its ability to crystallize, assuming simultaneously a viscid consistency, a yellow color, and a somewhat bitter, disagreeable taste. This is accompanied by an increase in the specific gravity above 1 and a better solubility in alcohol. It remains

doubtful whether this change is caused, according to de Varda,²¹ by polymerization of anethole or, according to Hoering and Grälert,²² by oxidation to anisaldehyde, anisic acid, and other products of oxidation, among them 4,4'-dimethoxystilbene, the so-called "photoanethole" (see Beilstein²³). The last-named compound is quite insoluble and, therefore, freshly prepared anethole upon standing sometimes becomes turbid. When recrystallized from glacial acetic acid or benzene, *di-p*-methoxystilbene melts at 214°–215°. These crystals show a fluorescence in solid form as well as in solution. It is possible that *di-p*-methoxystilbene does not form directly from anethole but from anisaldehyde as an intermediary product of the reaction.

Campbell²⁴ found that, on heating in the absence of air, anethole undergoes fission and dimerization resulting in the formation of 1,3-*di-p*-methoxyphenyl-2-methylpropane.

The following data are selected from the files of the New York laboratories of Fritzsche Brothers, Inc., and serve to illustrate the effect of light and air upon the physical properties of anethole.

	<i>Original Anethole</i>	<i>Exposed to Light and Air</i>	<i>Exposed to Air in the Dark</i>
Specific Gravity at 25°	0.986	1.114	1.080
Solubility	1.5 to 2 vol. and more of 90% al- cohol.	Miscible with 80% al- cohol. The solution has a decided blue fluorescence	0.5 vol. 80% alcohol and more. The solu- tion has a blue fluo- rescence
Acid Number	0	1.4	1.4
Aldehyde Con- tent as Anis- aldehyde	0.7%	25.0%	17.6%
Flavor	Sweet, anethole- like	Very harsh and bitter	Harsh and bitter

Note: The experiments and the control were permitted to stand undisturbed for a period of eighteen months.

Under the influence of acid reagents anethole forms various polymers. Orndorff, Terrasse and Morton²⁵ treated anethole with zinc chloride, while Puxeddu²⁶ used ferric chloride in ether and obtained a dimeric "metanethole" or dianethole m. 132°–133°, the structure of which was studied by Baker and Enderby.²⁷ Staudinger and Brunner,²⁸ and Staudinger and Dreher²⁹ prepared a hemicolloid polyanethole "anisoïn" by shaking anethole with small amounts of concentrated sulfuric acid or phosphoric acid, or with tin tetrachloride in benzene solution.

Goodall and Haworth³⁰ obtained a liquid dimer "isoanethole" on boiling anethole with methanol and hydrochloric acid. Balbiano and Paolini³¹ found that, on treatment with mercuric acetate, anethole yields a glycol $\text{CH}_3\text{O}\cdot\text{C}_6\text{H}_4\cdot\text{C}_3\text{H}_5(\text{OH})_2$. According to Varenne and Godefroy,³² the same

product is formed on treating anethole dibromides with alcoholic potassium in the cold. By the action of 20 per cent sulfuric acid this anethole glycol can be converted into anisketone.

According to Orndorff and Morton,³³ and Baril and Megrđichian,³⁴ anethole, when treated with picric acid in chloroform, yields a picrate consisting of orange-red needles m. 69°–70° which lose anethole on exposure to the air.

Studying the oxidation of anethole with molecular oxygen at 150°, Schulz and Treibs³⁵ obtained acetaldehyde, carbon dioxide, anisic acid and acetic acid, free and esterified. The amount of aldehydes, ketones and phenols present were quantitatively determined. When the oxidation was carried out at 20° in the presence of benzaldehyde, the following compounds were identified in addition to those mentioned above:

anisaldehyde
p-methoxyphenylacetone
p-methoxyphenylacetoin
 anethole glycol
 dimolecular anethole glycol ethers

Use.—Anethole is used most widely for the flavoring of all kinds of food products, especially confectionery. It forms an important constituent of beverages, alcoholic and nonalcoholic, particularly of the absinthe type so popular in France. Anethole also finds wide application for the flavoring of pharmaceutical preparations, especially dentrifices, mouth washes, gargles, etc.

It is used in some perfume compositions in order to impart a sweet note.

- ¹ *J. Am. Chem. Soc.* **52** (1930), 4090.
- ² *Am. Chem. J.* **23** (1900), 185.
- ³ *J. prakt. Chem.* II, **51** (1895), 424; II, **52** (1895), 194.
- ⁴ *J. Chem. Soc.* **127** (1925), 2640.
- ⁵ "Die Ätherischen Öle," 3d Ed., Vol. I, 605.
- ⁶ *Bull. soc. chim.* III, **21** (1889), 1076.
- ⁷ *J. Chem. Soc.* **123** (1923), 2702.
- ⁸ *Helv. Chim. Acta* **21** (1938), 748.
- ⁹ *J. prakt. Chem.* **148** (1937), 121. See also Kramli, *Magyar Biol. Kutatóintézet Munkái* **10** (1938), 452. *Chem. Abstracts* **33** (1939) 4971. Cf. Savitskiĭ and Makhnenko, *J. Gen. Chem. U.S.S.R.* **10** (1940), 1819. *Chem. Abstracts* **35** (1941), 4356. Monti and Dinelli, *Gazz. chim. ital.* **62** (1932), 368. Wallach and Müller, *Liebigs Ann.* **332** (1904); 318.
- ¹⁰ *Liebigs Ann.* **332** (1904), 326. Cf. Neber and Rauscher, *ibid.* **550** (1942), 182. *Chem. Abstracts* **37** (1943), 3411.
- ¹¹ *Compt. rend.* **203** (1936), 329.
- ¹² *Anales soc. españ. fís. quím.* **36** (1940), 44. *Chem. Abstracts* **34** (1940), 7288. *Anales fís. quím.* **37** (1941), 392. *Chem. Abstracts* **37** (1943), 1707.
- ¹³ *J. Chem. Soc.* (1941), 715.
- ¹⁴ "Die Ätherischen Öle," 3d Ed., Vol. I, 604.
- ¹⁵ *Sitz. Akad. Wiss. Leipzig* (1892), 318.
- ¹⁶ *J. Soc. Chem. Ind.* **42** (1923), 1T.
- ¹⁷ *Z. physik. Chem.* **78** (1911), 397.
- ¹⁸ *Parfums France*, April (1933), 88.

- ¹⁹ *Ber.* **23** (1890), 862.
²⁰ *Ion* **3** (1943), 410.
²¹ *Gazz. chim. ital.* I, **21** (1891), 183. *Chem. Zentr.* I (1891), 788.
²² *Ber.* **42** (1909), 1204. Cf. Milas, *J. Am. Chem. Soc.* **52** (1930), 739.
²³ "Handbuch der Organischen Chemie," Vol. VI, 1023.
²⁴ *J. Chem. Soc.* (1941), 672.
²⁵ *Am. Chem. J.* **19** (1897), 858.
²⁶ *Gazz. chim. ital.* I, **50** (1920), 149.
²⁷ *J. Chem. Soc.* (1940), 1094.
²⁸ *Helv. Chim. Acta* **12** (1929), 972.
²⁹ *Liebigs Ann.* **517** (1935), 99.
³⁰ *J. Chem. Soc.* (1930), 2482.
³¹ *Ber.* **35** (1902), 2997.
³² *Compt. rend.* **140** (1905), 591.
³³ *Am. Chem. J.* **23** (1900), 184.
³⁴ *J. Am. Chem. Soc.* **58** (1936), 1415.
³⁵ *Ber.* **77B** (1944), 377.

SUGGESTED ADDITIONAL LITERATURE

Ollivier Gaudin and Noël Lazac'h, "Sulfurized Derivatives of Anethole and Estragole," *Compt. rend.* **224** (1947), 577. *Chem. Abstracts* **41** (1947), 3441.

Feniculin

p-Anol prenyl ether

$C_{14}H_{18}O$

Mol. Weight 202.28

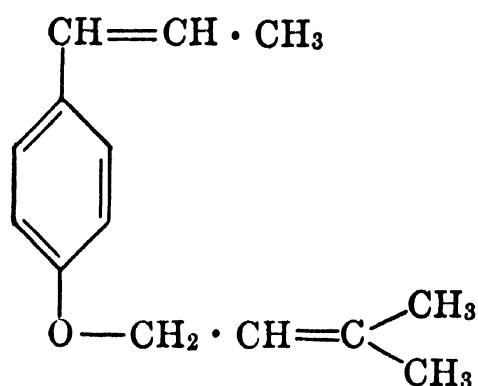

Feniculin

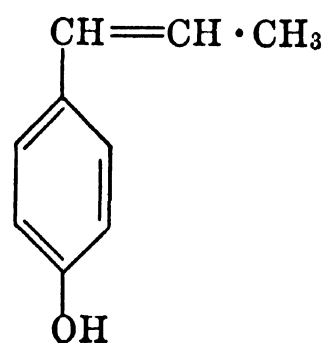

p-Anol

Occurrence.—Years ago Takens¹ isolated from the last runs of fennel oil and star anise oil a substance $C_{14}H_{18}O$ which, on heating to 260° , decomposed with effervescence yielding *p*-propenylphenol (= *p*-anol) $C_9H_{10}O$ (crystals from benzene), m. 93° – 94° . *p*-Anol possesses an odor of withering foliage.

More recently Späth and Bruck² submitted the substance $C_{14}H_{18}O$ isolated from fennel oil to a closer investigation and named it feniculin. Späth and Bruck found that feniculin is *p*-anol prenyl ether, suggesting the term

"prenol," for the primary γ,γ -dimethyl-allyl alcohol

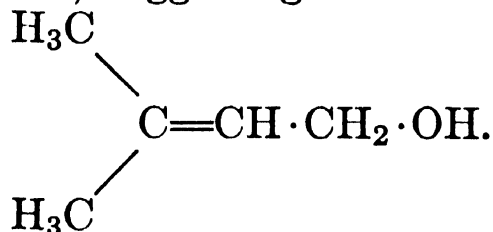

Späth and Bruck ³ proved the validity of the structural formula which they had suggested for feniculin by synthesizing *p*-anol prenyl ether from *p*-anol and prenyl bromide.

Isolation.—By crystallization from 90% methyl alcohol at -80° and fractional distillation, separating the cut $b_{0.04}$ 130° – 135° .

Identification.—Hydrogenation to tetrahydrofeniculin $b_{0.03}$ 100° – 110° , and cleavage of the isoamyl group by hydriodic acid.

The resulting *p*-*n*-propylphenol yields a phenylurethane m. 128.5° – 129° .

Conversion to *p*-anol by heating to 260° , methylation and oxidation to anisaldehyde which yields several derivatives. (*p*-Nitrophenylhydrazone m. 161° .)

Properties.—According to Späth and Bruck, ⁴ feniculin melts at 23.5° to 24.5° (in an evacuated tube). These authors and Takens ⁵ reported:

b_5	147°
$b_{0.04}$	130° – 135°
d_{15}	0.967

Use.—Feniculin, as such, is not used in our industries.

¹ *Riechstoff Ind.* **4** (1929), 8.

² *Ber.* **71** (1938), 2708.

³ *Ibid.*

⁴ *Ibid.*

⁵ *Riechstoff Ind.* **4** (1929), 8.

Allylpyrocatechol

$C_9H_{10}O_2$

Mol. Weight 150.17

1,2-Dihydroxy-4-allylbenzene. Hydroxychavicol

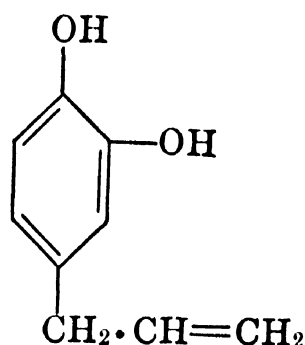

Occurrence.—Allylpyrocatechol has been identified in Java betel leaf oil.

Isolation.—By the formation of a water-soluble salt in an aqueous alkali solution and regeneration by acidification, etc. Thus, Java betel leaf oil is treated with dilute aqueous alkali, and the phenolate separated. The crude phenols are freed and fractionated, the allylpyrocatechol occurring in the fraction b_4 137° – 139° .

Identification.—Allylpyrocatechol can be characterized by the preparation of several derivatives:

(1) Dibenzoyl compound m. 71° – 72° , according to Gildemeister and Hoffmann.¹

(2) Schöpf and co-workers ² converted the 4-allylcatechol to the dibenzyl ether m. 37° – 38° by the action of benzyl chloride and potassium carbonate in acetone. Further action of silver benzoate, iodine and benzene on the derived dibenzyl ether gave the glycol [1,2-dihydroxy-3-(3',4'-dibenzyloxyphenyl)-propane], m. 82° – 83° .

Properties.—Allylpyrocatechol is a crystalline mass possessing a faint odor slightly reminiscent of creosote. From petrol ether or benzene, allylpyrocatechol crystallizes in the form of long, colorless needles m. 48° .

Gildemeister and Hoffmann,³ Perkin and Trikojus,⁴ Hurd and Puterbaugh,⁵ and Schöpf and co-workers⁶ reported the following properties:

m.	48° ^{3, 4, 6}	n_D^{29}	1.5600 ⁵
b_{16}	156° – 158° ⁴	$n_D^{7.5}$	1.5689 ⁵
b_{10}	147° – 149° ⁴		
b_7	141° – 144° ⁵		
b_4	139° ³		

Allylpyrocatechol is readily soluble in water and alcohol, the alcoholic solution developing a deep green color on treatment with ferric chloride.

Use.—Allylpyrocatechol is not used in our industries.

¹ "Die Ätherischen Öle," 3d Ed., Vol. I, 607.

² *Liebigs Ann.* **544** (1940), 51.

³ "Die Ätherischen Öle," 3d Ed., Vol. I, 607.

⁴ *J. Chem. Soc.* (1927), 1663.

⁵ *J. Org. Chem.* **2** (1937), 383.

⁶ *Liebigs Ann.* **544** (1940), 50.

Chavibetol

$C_{10}H_{12}O_2$

Mol. Weight 164.20

1-Methoxy-2-hydroxy-4-allylbenzene. "Betel phenol"

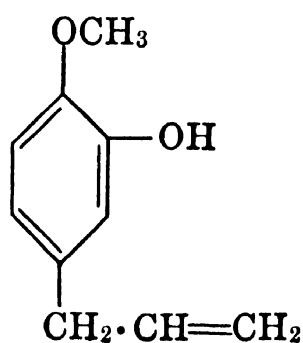

Where interest centers in products of synthetic nature, the work of Hirao¹ and of Schöpf et al.² should be consulted.

Occurrence.—Chavibetol occurs in betel oil from which the old name betel phenol is derived. Small quantities of chavibetol probably occur also in other essential oils—camphor oil, for instance.

Isolation.—In general, chavibetol is isolated by shaking the oil containing chavibetol with a dilute aqueous alkali solution, regeneration of the phenols by acidification, and fractional distillation of the phenols. Where the system is complicated by the presence of eugenol, purification may be effected by the following procedure as recommended by Schöpf and collaborators:³

Cool 42 g. of the phenolic mixture in 120 cc. of absolute ethyl alcohol containing 19 g. of potassium hydroxide, whereby the potassium eugenolate separates. The chavibetol may be recovered from the alcoholic filtrate. Further purification, where necessary, may be effected by preparation of the benzoate and fractional crystallization of the benzoates, according to Hirao.⁴

Identification.—According to Gildemeister and Hoffmann,⁵ chavibetol can be characterized by several methods:

(1) By the preparation of the benzoyl derivative m. 49°–50° (cf. also Hirao,⁶ and Schöpf and collaborators⁷).

(2) When treated with ferric chloride, an alcoholic solution of chavibetol gives a strong bluish-green color.

(3) On treatment with potassium hydroxide, chavibetol is converted into isobetel phenol (isochavibetol) m. 96°, b₁₉ 147° (cf. also Hirao⁸).

(4) According to Schöpf and co-workers,⁹ preparation of the benzyl ether m. 48° by treatment of the phenol with benzyl chloride and potassium carbonate, and crystallization from methyl alcohol.

Properties.—Chavibetol is a highly refractive liquid which, on cooling in a freezing mixture, congeals to a crystalline mass m. 8.5°. The following properties have been reported by Bertram and Gildemeister,¹⁰ Schimmel & Co.,¹¹ Hirao,¹² and Schöpf and co-workers:¹³

m.	8.5° ¹¹	d ₂₅ ²⁵	1.0646 ¹²
b.	254°–255° ¹⁰	d ₄ ²⁵	1.0613 ¹²
b ₁₂	124° ¹³	n _D ²⁵	1.5379 ¹²
b ₈	113° ¹²	n _D ²⁰	1.54134 ¹¹
b ₄	107°–109° ¹¹		

Use.—Chavibetol is not used in our industries.

¹ *Bull. Chem. Soc. Japan* **11** (1936), 181.

² *Liebigs Ann.* **544** (1940), 30.

³ *Ibid.*

⁴ *Bull. Chem. Soc. Japan* **11** (1936), 181.

⁵ "Die Ätherischen Öle," 3d Ed., Vol. I, 608.

⁶ *Bull. Chem. Soc. Japan* **11** (1936), 179.

⁷ *Liebigs Ann.* **544** (1940), 30.

⁸ *Bull. Chem. Soc. Japan* **11** (1936), 179.

⁹ *Liebigs Ann.* **544** (1940), 30.

¹⁰ *J. prakt. Chem.* II, **39** (1889), 350.

¹¹ *Ber. Schimmel & Co.*, Oct. (1907), 13. *Chem. Zentr.* II (1907), 1741.

¹² *Bull. Chem. Soc. Japan* **11** (1936), 183.

¹³ *Liebigs Ann.* **544** (1940), 40.

Eugenol

 $C_{10}H_{12}O_2$

Mol. Weight 164.20

1-Hydroxy-2-methoxy-4-allylbenzene. 4-Allylguaiacol. "Eugenic acid"

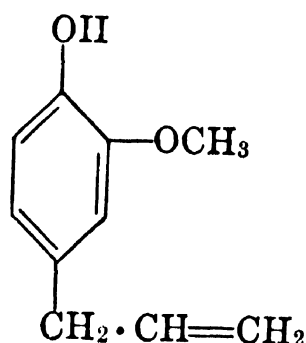

Occurrence.—Eugenol is the main constituent of several important volatile oils belonging to the family *Myrtaceae* and *Lauraceae*—for example, oil of clove, clove stem and leaf, pimenta berry and leaf, bay, and cinnamon leaf. In smaller quantities eugenol occurs in numerous volatile oils—for instance, cinnamon bark, camphor, calamus, Java citronella, ylang ylang, cananga, nutmeg, sassafras, myrrh, laurel, California laurel, galangal, in the oil extracted from acacia flowers, etc. Certain *Ocimum* species, such as *O. gratissimum*, contain considerable quantities of eugenol. Sabetay and Trabaud¹ reported 21 per cent of eugenol in the oil from the flowers of the Parma violet.

In some plants eugenol seems to occur as glucoside which, according to Bourquelot and Herissey,² is split by the ferment gease (from *Geum urbanum*).

Isolation.—By treatment of the oil with a 3% aqueous sodium hydroxide solution, extraction of the nonphenolic constituents with ether, acidification of the alkaline solution, and separation of the regenerated phenols which are subsequently fractionated. Eugenol distills without decomposition even at atmospheric pressure.

Hunger³ suggested isolating eugenol from oil of clove, cinnamon leaf or pimenta by first preparing a **concentrated** alkaline solution of eugenol, by removing the non-eugenolic constituents through steam distillation, by neutralization (acidification) at low temperature, and by steam distillation of the freed eugenol.

Rowaan and Insinger⁴ recommend pretreatment with tartaric acid paste and the use of potassium hydroxide to reduce the difficulties of emulsion formation.

Identification.—(1) Eugenol can be characterized by the preparation of several derivatives:

(a) On treatment with benzoyl chloride, eugenol forms a benzoate m. 69.5°, according to Ikeda et al.⁵ McKie⁶ suggested a method of estimating the composition of mixtures of eugenol and isoeugenol through the melting point curves of their benzoates, eutectic 25.5% isoeugenol benzoate m. 56.5°.

(b) Phenylurethane m. 97°, according to Junge.⁷

(c) Mercury derivative from mercuric acetate m. 95°–96°, hydrate m. 120.5°–121.5°. By shaking with dilute hydrochloric acid, eugenol is regenerated readily (cf. Priester⁸).

(d) Eugenol piperazine m. 99°; this compound gives characteristic precipitates with alkaloids, thus it is useful in micro work (Sanna and Sorarù⁹).

(e) 2,4-Dinitrophenyl ether m. 114°–115°, according to Bost and Nicholson.¹⁰ This compound is prepared by treating eugenol in alkaline solution with 2,4-dinitrochlorobenzene.

(f) Dibromide m. 80° , tetrabromide m. 118° – 119° , as recorded by Gildemeister and Hoffmann.¹¹

(2) Color reactions:

In a cold saturated aqueous solution of ferric chloride, eugenol gives a turbid, grayish-yellow; in 2% alcoholic solution a blue color, which fades to gray-yellow in 15 min.

Bezssonoff's reagent gives a positive reaction (blue color) in very small concentration, according to Sabetay.¹²

Quantitative Determination.—For the quantitative determination of eugenol, see Vol. I, Chapter 4, "Examination and Analysis of Essential Oils, Synthetics, and Isolates," p. 291.

Properties.—Eugenol is a faintly yellow liquid possessing a strong odor of cloves and a burning taste. The following properties have been reported by Waterman and Priester,¹³ Erdmann,¹⁴ Junge,¹⁵ Fykman,¹⁶ Gildemeister and Hoffmann,¹⁷ and (Lauffer and Ingalls) Odorgraphia Committee:¹⁸

f.p.	10.3° ¹⁸	d_4^{25}	1.0651 ¹⁸
b.	253.1° – 253.4° ¹⁸	d_4^{20}	1.0664 ¹³
$b_{749.5}$	252° ¹⁴	$d_{14.5}$	1.072 ¹⁶
b_{12-13}	123° ¹⁴	n_D^{20}	1.5410 ^{13,15}
b_{10}	121.3° ¹⁸	$n_D^{14.5}$	1.5439 ¹⁶
b_5	110.3° ¹⁸		
	111° ¹⁵		
b_4	106.4° ¹⁸		
Sol.	Soluble in 5–6 vol. of 50% alcohol, in 2–3 vol. of 60% alcohol, or in 1–2 vol. of 70% alcohol. ¹⁷ One cc. of eugenol dissolves in 4.27 cc. of 50% alcohol at 25° ; in 5.22 cc. of 50% alcohol at 15° ; in 12.70 cc. of 2% sodium hydroxide at 25° . ¹⁸		

On heating with potassium hydroxide, eugenol is converted to isoeugenol.

Use.—Eugenol is widely used in pharmaceutical preparations, in perfumes, cosmetics, and for the scenting of soaps. It serves for the flavoring of all kinds of food products, especially meats, sausages, table sauces, etc. The main use of eugenol, however, is as a starting material for the making of high quality vanillin.

¹ *Compt. rend.* **209** (1939), 843.

² *Ibid.* **140** (1905), 870.

³ *Seifensieder-Ztg.* **68** (1941), 95. *Chem. Abstracts* **35** (1941), 3765.

⁴ *Chem. Weekblad* **36** (1939), 642.

⁵ *J. Chem. Soc. Japan* **61** (1940), 583. *Chem. Abstracts* **36** (1942), 6754. Cf. Junge, *Riechstoff Ind.* **7** (1932), 112; and Tiemann and Kraaz, *Ber.* **15** (1882), 2067.

⁶ *J. Chem. Soc.* **119** (1921), 777.

⁷ *Riechstoff Ind.* **7** (1932), 112. Cf. Weehuizen, *Rec. trav. chim.* **37** (1917), 268; and Claisen, *Liebigs Ann.* **418** (1919), 120.

- ⁸ *Rec. trav. chim.* **57** (1938), 811.
⁹ *Rend. seminar. facoltà sci. Univ. Cagliari* **12** (1942), 34. *Chem. Zentr.* II (1943), 1278. *Chem. Abstracts* **38** (1944), 5504.
¹⁰ *J. Am. Chem. Soc.* **57** (1935), 2369.
¹¹ "Die Ätherischen Öle," 3d Ed., Vol. I, 610.
¹² *Riechstoff Ind. Kosmetik* **13** (1938), 84.
¹³ *Rec. trav. chim.* **48** (1929), 1272.
¹⁴ *J. prakt. Chem.* II, **56** (1897), 147.
¹⁵ *Riechstoff Ind.* **7** (1932), 112.
¹⁶ *Ber.* **23** (1890), 862.
¹⁷ "Die Ätherischen Öle," 3d Ed., Vol. I, 609.
¹⁸ *Ind. Eng. Chem., News Ed.* **11** (1933), 114.

Eugenol Acetate

C₁₂H₁₄O₃

Mol. Weight 206.23

Aceteugenol. Acetyl eugenol.

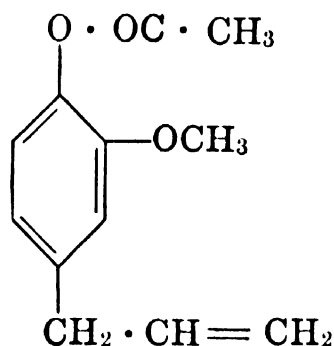

Occurrence.—Eugenol acetate occurs in the oil derived from dried clove buds but not in oil of clove stems.

Isolation.—Eugenol acetate can be isolated from a mixture with eugenol by treatment with dilute aqueous alkali in the cold whereby the eugenol is removed, and the ester is then fractionated. This removal of the free phenol, according to Rowaan and Insinger,¹ is best effected by the use of potassium hydroxide and a pretreatment with a small amount of tartaric acid paste to reduce emulsion formation.

Identification.—By saponification:

When boiled with a concentrated solution of sodium hydroxide, eugenol acetate forms sodium acetate and sodium eugenolate which, according to Erdmann,² separates as a white crystalline mass. The eugenol is readily recovered by acidification and identified as such.

Properties.—The following properties have been reported by Erdmann,³ Thoms,⁴ and Schimmel & Co.:⁵

m.	30° ⁴	d ₁₅ ¹⁵	1.087 ⁵
	29° ^{3,5}	d ₁₅	1.0842 ³ (undercooled)
b ₇₅₂	281°–282° ³	n _D ²⁰	1.52069 ⁵
b ₁₃	163°–164° ⁴		
b _{8.5}	145°–146° ³		
b ₆	142°–143° ⁵		

Use.—Eugenol acetate is used in imitation spice oils. Since eugenol acetate has less of a tendency to discolor than eugenol, it often serves in perfumes as a substitute for eugenol. This holds true particularly of compositions for the scenting of soaps.

¹ *Chem. Weekblad* **36** (1939), 642.

² *J. prakt. Chem.* [2], **56** (1897), 147.

³ *Ibid.*

⁴ *Arch. Pharm.* **241** (1903), 600.

⁵ *Ber. Schimmel & Co.*, Oct. (1903), 51.

Methyleugenol

$C_{11}H_{14}O_2$

Mol. Weight 178.22

Eugenol methyl ether. 1,2-Dimethoxy-4-allylbenzene. 4-Allylveratrole

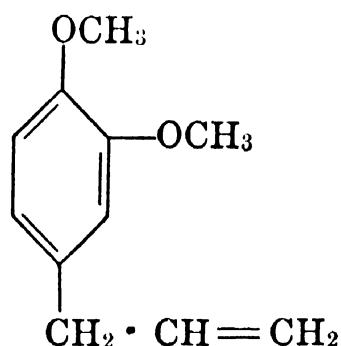

Occurrence.—Methyleugenol frequently accompanies eugenol in volatile oils; it has been found in oil of citronella, Canada snakeroot, California laurel, bay, pimenta, in the oil extracted from acacia flowers, in ‘tea-tree oil,’ and several others.

Isolation.—By fractional distillation.

Identification.—Methyleugenol can be characterized by several methods:

(1) By the preparation of bromoeugenol methyl ether dibromide $(\text{CH}_3\text{O})_2 \cdot \text{C}_6\text{H}_2\text{Br} \cdot \text{C}_3\text{H}_5\text{Br}_2$. Underwood, Baril and Toone¹ developed this method:

Dissolve 0.45 g. of methyleugenol in 5 cc. of dry ether and in the course of 10 min. add 0.8 g. of bromine; during the bromination cool the mixture in ice and subsequently allow to stand at room temperature for one-half hour. Cool in an ice-hydrochloric acid bath. Induce crystallization by scratching the wall of the container with a glass rod. Filter the solid, wash with 3 cc. of cold alcohol. Recrystallize from 8 cc. of absolute alcohol at 60°. The yield is 0.88 g. of needles m. 77.5°–78°, in agreement with the findings of Wassermann,² and Bertram and Gildemeister.³

(2) By the preparation of eugenol methyl ether picrate. According to Baril and Megrđichian,⁴ this compound crystallizes from chloroform in the form of red-brown rhombic crystals m. 114°–115°.

(3) On oxidation, methyleugenol yields principally veratric acid (3,4-dimethoxybenzoic acid). Graebe and Borgmann⁵ used for this purpose potassium dichromate in glacial acetic acid, whereas Luff, Perkin and Robinson⁶ oxidized methyleugenol in acetone with a saturated aqueous solution of potassium permanganate and obtained the same product. (Aside from veratric acid, a little homoveratric acid [3,4-dimethoxyphenyl acetic acid] is also formed but can readily be separated. Recrystallized from

water, the monohydrate of homoveratric acid melts at 82°, while the anhydrous form melts at 98°.) When recrystallized from water, veratric acid melts at 179°. Oxidizing methyleugenol with potassium permanganate, Wallach and Rheindorff⁷ found that veratric acid melts at 179°–180°.

(4) By the preparation of methyleugenol nitrite m. 125°, according to Wallach.⁸

(5) An addition product can be prepared by shaking the ether and mercuric acetate in water. It is soluble in water but, on evaporation and "seeding," a compound m. 69°–70° will be obtained, according to Priester.⁹ The ether is readily regenerated therefrom by cold hydrochloric acid.

Properties.—Methyleugenol is a somewhat viscid liquid with an odor similar to that of eugenol but fainter. The following properties have been reported by Gildemeister and Hoffmann,¹⁰ Abati,¹¹ Bertram and Gildemeister¹² and Eykman.^{13,14}

b.	248°–249° ¹⁰	n_D^{17}	1.5383 ¹¹
b_{11}	128°–129° ¹²	Sol.	Soluble in 4–5 vol. of 60% alcohol, in 1–2 vol. of 70% alcohol ¹⁰
$d_4^{15.3}$ (vac.)	1.0386 ¹⁴		
d_{11}	1.041 ¹³		

Use.—Methyleugenol is used quite widely in perfume compositions of the carnation type and in bouquets of oriental character. Its odor is softer than that of eugenol and, therefore, methyleugenol serves as a modifier of eugenol.

¹ *J. Am. Chem. Soc.* **52** (1930), 4090.

² *Jahresber. Chem.* (1879), 520.

³ *J. prakt. Chem.* II, **39** (1889), 354.

⁴ *J. Am. Chem. Soc.* **58** (1936), 1415.

⁵ *Liebigs Ann.* **158** (1871), 282.

⁶ *J. Chem. Soc.* **97** (1910), 1138.

⁷ *Liebigs Ann.* **271** (1892), 306.

⁸ *Ibid.*, 307.

⁹ *Rec. trav. chim.* **57** (1938), 816.

¹⁰ "Die Ätherischen Öle," 3d Ed., Vol. I, 611.

¹¹ *Gazz. chim. ital.* **40**, pt. 2 (1910), 91.

¹² *J. prakt. Chem.* II, **39** (1889), 354.

¹³ *Ber.* **23** (1890), 862.

¹⁴ *Rec. trav. chim.* **14** (1895), 189.

Isoeugenol

 $C_{10}H_{12}O_2$

Mol. Weight 164.20

2-Methoxy-4-propenylphenol. 1-Hydroxy-2-methoxy-4-propenylbenzene.
4-Propenylguaiaicol

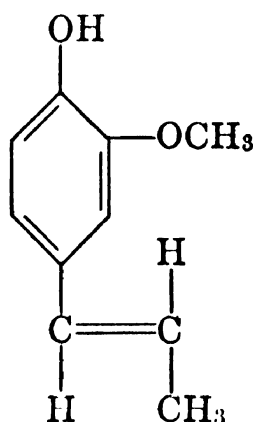

Isoeugenol is prepared by various methods of treating eugenol with potassium hydroxide—for example, in amylalcoholic solution. (For details, see patent literature.)

According to Boedecker and Volk,¹ and von Auwers,² commercial isoeugenol is a mixture of *cis*- and *trans*- isomers; it freezes at 0° to 5°. The two first-named authors found that the commercial product, when dissolved in 1.7 parts of warm 15 per cent sodium hydroxide solution, yields on cooling a sodium salt which can be recrystallized from 2 parts of water, and on acidification with dilute acetic acid forms *trans*-isocugenol m. 30°–33°. An isoeugenol possessing a melting point of 33° could be regarded as the result of complete transformation of the *cis*- form into the alkali resistant *trans*- form.

Occurrence.—Isocugenol occurs in oil of ylang ylang, champaca, nutmeg, and in a few other volatile oils.

Isolation.—By the usual method of separating phenols from volatile oils, followed by distillation (see “Eugenol”).

Identification.—Isoeugenol can be characterized by the preparation of several derivatives:

(1) 3,5-Dinitrobenzoate m. 158.4° (corr.), according to Phillips and Keenan.³ Obtained by treating isoeugenol with 3,5-dinitrobenzoyl chloride in pyridine and crystallization from *n*-butyl alcohol.

(2) α -Naphthylurethane m. 149°–150°, according to French and Wirtel.⁴ Obtained by treating isocugenol with α -naphthylisocyanate in the presence of traces of anhydrous trimethylamine, and crystallized from ligroine.

(3) Monobromoisocugenol dibromide m. 138°–139°, according to Gildemeister and Hoffmann.⁵

(4) Piperazine derivative prepared by evaporating an alcohol solution of piperazine and isoeugenol (molecular ratios of 1:2). The derivative is rose colored and melts at 79°. It forms characteristic complexes with alkaloids, useful in micro work (Sanna and Sorarù).⁶

For further derivatives see “Properties.”

Quantitative Determination.—For the quantitative determination, see Vol. I, Chapter 4, "Examination and Analysis of Essential Oils, Synthetics, and Isolates," p. 291.

Properties.—As pointed out, commercial isoeugenol is usually a mixture of *cis*- and *trans*- isomers which freezes at low temperature. The *trans*- form has been prepared in the form of large, water clear plates m. 32°. The *cis*- form is liquid.

The following properties of the two isomers have been reported by Boeckler and Volk,⁷ by von Auwers,⁸ and by Junge:⁹

	<i>Trans</i> -isoeugenol	<i>Cis</i> -isoeugenol
m.	30°–33° ⁷	...
	33°–34° ^{8,9}	...
b ₁₃	141°–142° ⁷	134°–135° ⁷
b ₁₂	140° ⁸	...
b ₁₁	...	133° ⁸
b ₅	118° ⁹	115° ⁹
b ₁₋₂	...	98° ⁷
d ₄ ²⁰	1.0852 ⁷	1.0851 ⁷
	1.087 ⁸	1.088 ⁸
n _D ²⁰	1.5782 ⁷	1.5726 ⁷
	1.57862 ⁹	1.57002 ⁹
n _{He} ²⁰	1.5778 ⁸	1.5724 ⁸
Acetate	m. 79° ^{8,9}	Liquid ^{8,9}
Benzoate	m. 104° ⁹	68° ⁹
Phenylurethane	m. 152° ⁹	118° ⁹
FeCl ₃ reaction	Yellowish-green ⁹	Olive green ⁹

Technical isoeugenol is a somewhat viscid, clear liquid with an odor characteristic of carnation and reminiscent of eugenol, but finer, more suave, and much more lasting. Gildemeister and Hoffmann,¹⁰ Perkin,¹¹ and Eykman¹² recorded these properties for technical isoeugenol:

cong. pt.	17.3° ¹⁰	d ₂₅ ²⁵	1.0839 ¹¹
m.	18°–20° ¹⁰	d ₁₅ ¹⁵	1.087–1.091 ¹⁰
b.	267.5° ¹¹ (corr.)		1.0904 ¹⁰
b ₇₅₀	270° ¹⁰	n _D ²⁰	1.570–1.576 ¹⁰
b _{3.5}	111°–112° ¹⁰	n _D	1.5680 ¹²
Sol.	Soluble in 5–6 vol. of 50% alcohol ¹⁰		

Isoeugenol, when treated with acids or acid reagents, yields di-isoeugenol, the structure of which has been studied by Haworth and Mavin,¹³ by Puxeddu,¹⁴ and by Puxeddu and Rattu.¹⁵

On treatment with picric acid in chloroform solution, isoeugenol forms a picrate, crystallizing in dark red silky needles m. 46° – 47.5° , unstable in air, according to Baril and Megrđichian.¹⁶

On oxidation, isoeugenol yields vanillin.

Use.—Isoeugenol is an important aromatic used in the compounding of all kinds of floral and fancy bouquets. It forms the base of most carnation scents. Because of its pleasant, persistent and strong odor, isoeugenol has become one of the most useful ingredients in perfume work. It serves equally well for the scenting of cosmetics and soaps.

¹ *Ber.* **64** (1931), 62.

² *Ber.* **68** (1935), 1346.

³ *J. Am. Chem. Soc.* **53** (1931), 1926

⁴ *Ibid.* **48** (1926), 1738.

⁵ "Die Ätherischen Öle," 3d Ed., Vol. I, 613.

⁶ *Rend. seminar. facoltà sci. Univ. Cagliari* **12** (1942), 34. *Chem. Abstracts* **38** (1944), 5504.

⁷ *Ber.* **64** (1931), 62.

⁸ *Ber.* **68B** (1935), 1346.

⁹ *Riechstoff Ind.* **7** (1932), 112. *Chem. Abstracts* **27** (1933), 4530.

¹⁰ "Die Ätherischen Öle," 3d Ed., Vol. I, 612.

¹¹ *J. Chem. Soc.* **69** (1896), 1227.

¹² *Ber.* **23** (1890), 862.

¹³ *J. Chem. Soc.* (1931), 1363.

¹⁴ *Gazz. chim. ital.* **66** (1936), 710.

¹⁵ *Ibid.* **67** (1937), 654.

¹⁶ *J. Am. Chem. Soc.* **58** (1936), 1415.

SUGGESTED ADDITIONAL LITERATURE

Aleardo Oliverio, "The So-called di-Isoeugenol," *Gazz. chim. ital.* **73** (1943), 270. *Chem. Abstracts* **40** (1946), 3106.

Methylisoeugenol

$C_{11}H_{14}O_2$

Mol. Weight 178.22

Isoeugenol methyl ether. 1,2-Dimethoxy-4-propenylbenzene. 4-Propenylveratrole

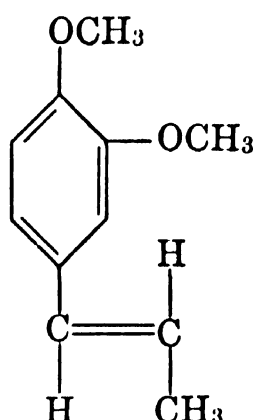

Occurrence.—Methylisoeugenol occurs in oil of *Cymbopogon javanensis*, *Asarum arifolium*, and in a few other volatile oils.

Isolation.—By fractional distillation.

Identification.—(1) Methylisoeugenol can be readily characterized by the preparation of its dibromide m. 101° – 101.5° . Underwood, Baril and Toone¹ developed the following procedure:

In the course of 8 min. add 0.4 g. of bromine to 0.45 g. of methylisoeugenol dissolved in 5 cc. of dry ether. During the treatment cool the mixture in ice; subsequently allow to stand for half an hour at room temperature, then cool in an ice-hydrochloric acid mixture. Induce crystallization by scratching and recrystallize the solid from 8 cc. of dry ether. The yield of dibromide observed was 0.61 g. of plates m. 101° – 101.5° .

(2) Bruckner² prepared a series of derivatives from the reaction of methylisoeugenol and maleic anhydride in the ratio of 6.0 g.:2.94 g. After washing the residue with ether and benzene a 7.2 g. condensate ($C_{49}H_{50}O_{18}$), m. 300° – 305° , is obtained. The benzene solution yields 3.3 g. of a characteristic dicarboxylic anhydride m. 139° , the free acid derived therefrom melting at 116° – 118° .

Properties.—Methylisoeugenol is a colorless, slightly viscid liquid; its odor resembles that of isoeugenol. Methylisoeugenol exists as *cis*- and as *trans*-isomer. The commercially available product is most probably a mixture of both forms.

Boedecker and Volk³ reported the following properties for the *cis*- form which is prepared from the liquid stereoisomer of isoeugenol:

d_4^{20}	1.0521
n_D^{20}	1.5616

Boedecker and Volk,⁴ and von Auwers⁵ reported these properties for the *trans*- form derived from the crystalline stereoisomer of isoeugenol:

m.	16° – 17°
d_4^{20}	1.0528
n_D^{20}	1.5692

The following properties of methylisoeugenol have been reported by Gilde-meister and Hoffmann,⁶ and by Eykman:⁷

cong. pt.	4.5° ⁶	d_{15}^{15}	1.0568 ⁶
m.	5.5° – 6.5° ⁶	$d_{11.5}$	1.064 ⁷
b.	270° ⁶	n_D^{15}	1.56732 ⁶
b_8	136° – 137° ⁶	$n_D^{11.5}$	1.5720 ⁷
Sol.	Soluble in 6.5 to 7.5 vol. of 60% alcohol, soluble in 1.5 to 2 vol. of 70% alcohol ⁶		

On treatment with dry hydrochloric acid, isoeugenol methyl ether, according to Szeki,⁸ yields a dimer (*bis*-isoeugenol methyl ether of Beilstein) which crystallizes from dilute alcohol or dilute acetic acid in the form of colorless needles m. 106° . Haworth and Mavin⁹ obtained this dimer by refluxing

isoeugenol methyl ether with 20 parts of 5 normal methyl alcoholic hydrochloric acid.

When treated with 1,3,5-trinitrobenzene, isoeugenol methyl ether yields a compound m. 69° – 70° , according to Sudborough and Beard.¹⁰

Use.—Methylisoeugenol is used, like isoeugenol, in perfumes and for the scenting of cosmetics and soaps.

¹ *J. Am. Chem. Soc.* **52** (1930), 4090.

² *Ber.* **75B** (1942), 2041.

³ *Ber.* **64** (1931), 64.

⁴ *Ibid.*

⁵ *Ber.* **68** (1935), 1347.

⁶ "Die Ätherischen Öle," 3d Ed., Vol. I, 613.

⁷ *Ber.* **23** (1890), 862.

⁸ *Ber.* **39** (1906), 2422.

⁹ *J. Chem. Soc.* (1931), 1365.

¹⁰ *Ibid.* **99** (1911), 214.

Peonol

$C_9H_{10}O_3$

Mol. Weight 166.17

2-Hydroxy-4-methoxyacetophenone

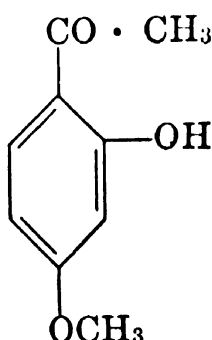

Occurrence.—Goris and Canal¹ isolated from the roots of *Primula auricula* L., by steam distillation, an essential oil which for the greater part consisted of an aromatic ketone, viz., peonol.

It had previously been identified in the root stock of *Peonia arborea* as a glucoside and likewise in *Peonia moutan* (China and Japan).

Identification.—Peonol forms a number of derivatives which are suitable for defining this ketone:

(1) Phenyl hydrazone m. 108° (soluble in hot 10% NaOH); 2,4,6-tribromophenyl hydrazone m. 162° (soluble in boiling 10% NaOH); hydrazone m. 73° – 75° from alcohol (soluble in cold 10% NaOH), all according to Adams.²

(2) *p*-Thiocyanophenyl hydrazone m. 157° – 158.5° , according to Horiuchi and Kiuchi.³

(3) Bromopeonol m. 169° , and tribromobromopeonol m. 123° – 124° , by Adams.⁴

(4) Azine m. 226° – 227° from acetic acid (insoluble in boiling 10% NaOH), by Adams.⁵

(5) *p*-Nitrophenyl hydrazone (red) m. 238° – 239° , by Mauthner.⁶

(6) Semicarbazone m. 250° , by Goris and Canal.⁷

(7) Oxime m. 130° – 131° , by Goris and Canal;⁸ and acetyl derivative m. 123° , according to Lindemann, Könitzer and Romanoff.⁹

Properties.—The melting point of 50° has been confirmed by several investigators, among them Adams,¹⁰ Mauthner,¹¹ and Goris and Canal.¹²

Eijkman, Bergema and Henrard¹³ reported:

$d^{81.2}$	1.1310
$n_{\alpha}^{81.2}$	1.54322

Peonol is easily soluble in alcohol, ether, chloroform, carbon disulfide or benzol.

This phenolic ketone forms metallic complexes with a number of the heavy metals, viz., $(C_9H_9O_3)_2Ni$ from nickel salts; $(C_9H_9O_3)_2Cu$ from those of copper, according to Pfeiffer, Buchholz and Bauer.¹⁴ Hein¹⁵ reports the chromium salt $(C_{27}H_{27}O_9Cr \cdot O \cdot 25 CHCl_3)$ as melting at 270°–271° (uncorr.).

Use.—Peonol is used very little, if at all, in the perfume, soap, or flavor industries.

¹ *Compt. rend.* **202** (1936), 1351.

² *J. Am. Chem. Soc.* **41** (1919), 260.

³ *J. Pharm. Soc. Japan* **56** (1936), 690. *Chem. Abstracts* **31** (1937), 2591.

⁴ *J. Am. Chem. Soc.* **41** (1919), 261, 262.

⁵ *Ibid.*, 260.

⁶ *J. prakt. Chem.* **136** (1933), 208. See also *Math. naturw. Anz. ungar. Akad. Wiss.* **50** (1933), 468.

⁷ *Compt. rend.* **202** (1936), 1351.

⁸ *Ibid.*

⁹ *Liebigs Ann.* **456** (1927), 304.

¹⁰ *J. Am. Chem. Soc.* **41** (1919), 247.

¹¹ *J. prakt. Chem.* **136** (1933), 205. *Math. naturw. Anz. ungar. Akad. Wiss.* **50** (1933), 468.

¹² *Compt. rend.* **202** (1936), 1351.

¹³ *Chem. Zentr. I* (1905), 815. *Chem. Weekblad* **2** (1905), 59, 79.

¹⁴ *J. prakt. Chem.* **129** (1931), 163. See also Ephraim, *Ber.* **64B** (1931), 1210.

¹⁵ *J. prakt. Chem.* **153** (1939), 172.

Safrole

$C_{10}H_{10}O_2$

Mol. Weight 162.18

1,2-Methylenedioxy-4-allylbenzene. Allylpyrocatecholmethylene ether

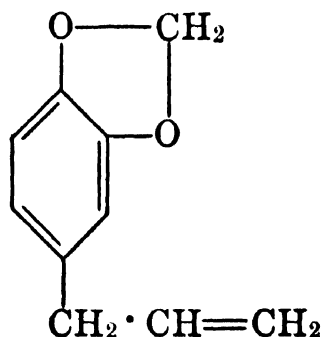

Occurrence.—Safrole is the main constituent of several important volatile oils—for example, American sassafras oil, Brazilian sassafras oil (*Ocotea pretiosa?*) and star anise oil (*Illicium verum*). Camphor oil contains considerable

quantities of safrole. This phenol ether also occurs as a minor constituent in numerous other volatile oils—for instance, in oil of nutmeg, American wormseed, cinnamon leaf, California laurel, probably ylang ylang, etc. According to Foote,¹ oil of *Illicium parviflorum* Michx. contains 90 per cent safrole, the highest safrole content of any volatile oil yet reported.

Isolation.—(1) By cooling the oil, or the safrole containing fraction of the oil, to at least -12°C (cf. Foote²).

(2) By fractional distillation, followed by cooling and crystallization. (Regarding distillation of safrole in mixtures consult Brauer.³)

(3) Where safrole may be contaminated by oily constituents in an essential oil as in red camphor oil, the method of Ikeda and Takeda⁴ may be employed advantageously to determine the safrole by preparation of the addition product with mercuric acetate and sodium chloride in dilute acetone. The precipitate so formed should be filtered in a gooch and weighed, and with a correction factor used to define the percentage of safrole in the sample.

This complex hydroxy chloride of safrole [$\text{C}_{10}\text{H}_{10}\text{O}_2(\text{OH})\text{HgCl}$], according to Tsukamoto,⁵ is readily decomposed to regenerate safrole either by hydrochloric acid, or sodium sulfide and zinc in potassium hydroxide. The oxychloride melts at 141° – 142° , according to Fujita.⁶

Identification.—Safrole can be identified by several methods:

(1) By the preparation of derivatives:

(a) Tribromosafrole dibromide or “pentabromosafrole.” Underwood, Baril and Toone⁷ developed the following method:

Dissolve 0.41 g. of safrole in 3 cc. of alcohol and treat with 2 g. of bromine in the course of 8 min.; heat for 15 min. on a water bath, then cool. Recrystallize the solid from 7 cc. of benzene. Needles m. 169° – 170° .

(b) Safrole picrate crystallizes from chloroform in the form of long orange-red blades m. 104° – 105.5° , according to Baril and Megrđichian.⁸

(2) By oxidation:

Oxidizing safrole in acetone with aqueous potassium permanganate, Luff, Perkin and Robinson⁹ obtained piperonylic acid m. 228° . Decker¹⁰ found that a small quantity of piperonylacetic acid, m. 87° – 88° , is formed as side reaction.

Foote¹¹ reported on the oxidation of safrole by the method of Fittig and Mielch¹² with alkaline potassium permanganate. The oxidation should be carefully controlled because of the variety of products obtainable. Foote suggested the following procedure:

Disperse 4 cc. of the sample in 240 cc. of a 1% sodium hydroxide solution contained in an 800-cc. flask. To this slowly add with agitation 200 cc. of a 5% potassium permanganate solution. Heat on a water bath for 1 hr. Filter hot and cool. Acidify the filtrate with sulfuric acid. The precipitated piperonylic acid is filtered off, washed with water, and recrystallized from hot alcohol. It melts at 228° .

On oxidation with potassium dichromate and dilute sulfuric acid, safrole yields piperonal (heliotropin) m. 35° , according to Power and Lees.¹³

Gildemeister and Hoffmann¹⁴ reported that, on careful oxidation with permanganate, a glycol m. 82° – 83° is formed first, and with further oxidation α -homopiperonylic acid m. 127° – 128° .

(3) Note section on “Isolation” regarding mercury derivatives.

Quantitative Determination.—See Vol. I, Chapter 4, “Examination and Analysis of Essential Oils, Synthetics, and Isolates,” p. 239.

Properties.—Safrole is a colorless liquid, which becomes yellow on standing. Its odor and flavor resemble sassafras. On cooling, safrole forms a crystalline mass.

The following properties have been reported by Gildemeister and Hoffmann,¹⁵ Eijkman,¹⁶ Waterman and Priester,¹⁷ Perkin and Trikojus,¹⁸ Priester,¹⁹ and von Rechenberg:²⁰

cong. pt.	11° ^{15,17,19}	d_4^{20}	1.100 ¹⁷
m.	11° ¹⁹	d_{12}	1.110 ¹⁶
b.	234.5° ²⁰ (corr.)	n_D^{20}	1.536–1.540 ¹⁵
b ₇₅₉	233° ¹⁵		1.5383 ¹⁷
b _{10–11}	100°–101.5° ¹⁸		1.5381 ¹⁸
b ₄	91° ¹⁵	n_D^{12}	1.5420 ¹⁶

Crude isolates from natural sources are reported to melt at 7°–8°, according to Eijkman²¹ and Foote.²²

Safrole is insoluble in water, soluble in alcohol or ether. Volatile with steam.

Ciamician and Silber²³ found that safrole and isosafrole, when dissolved in concentrated sulfuric acid, develop an intense red color, while heating with phosphoric acid, according to Ono and Hirayama,²⁴ yields allylpyrocatechol.

On treatment with 1,3,5-trinitrobenzene, safrole yields a crystalline compound m. 51°, according to Sudborough and Beard.²⁵

When heated with alkalies, safrole is converted to isosafrole. Sodium alcoholate decomposes the methylenedioxy group after rearrangement to isosafrole (cf. Ono and Imoto²⁶).

Use.—Safrole is used widely for the flavoring of certain beverages, chewing gums, pharmaceuticals, oral preparations, tooth pastes, etc., and for the scenting of soaps. The principal use, however, is for the conversion to isosafrole and the manufacture of heliotropin.

¹ *J. Am. Pharm. Assocn.* **27** (1938), 574.

² *Ibid.*

³ *Ber. Schimmel & Co., Jubiläums-Ausgabe* (1929), 153.

⁴ *J. Chem. Soc. Japan* **57** (1936), 565. *Chem. Abstracts* **30** (1936), 7497. Cf. Matejika, *Ber.* **69B** (1936), 274; Huzita and Nakahara, *J. Chem. Soc. Japan* **62** (1941), 5. *Chem. Abstracts* **37** (1943), 3882.

⁵ *J. Pharm. Soc. Japan* **50** (1930), 7. *Chem. Abstracts* **24** (1930), 1853.

⁶ *J. Chem. Soc. Japan* **58** (1937), 1185. *Chem. Abstracts* **32** (1938), 3904. Cf. also Priester, *Rec. trav. chim.* **57** (1938), 811.

⁷ *J. Am. Chem. Soc.* **52** (1930), 4090.

⁸ *Ibid.* **58** (1936), 1415.

⁹ *J. Chem. Soc.* **97** (1910), 1139.

¹⁰ *Liebigs Ann.* **395** (1913), 295.

¹¹ *J. Am. Pharm. Assocn.* **27** (1938), 574.

¹² *Liebigs Ann.* **152** (1869), 40.

¹³ *J. Chem. Soc.* **85** (1904), 638.

¹⁴ "Die Ätherischen Öle," 3d. Ed., Vol. I, 614.

¹⁵ *Ibid.*

- ¹⁶ *Rec. trav. chim.* **4** (1885), 32. *Ber.* **23** (1890), 862.
¹⁷ *Rec. trav. chim.* **47** (1928), 849.
¹⁸ *J. Chem. Soc.* (1927), 1663.
¹⁹ *Rec. trav. chim.* **57** (1938), 811.
²⁰ "Einfache und fraktionierte Destillation," 2 Aufl. (Miltitz 1923), 218.
²¹ See Gildemeister and Hoffmann, "Die Ätherischen Öle," 3d Ed., Vol. I, 614.
²² *J. Am. Pharm. Assocn.* **27** (1938), 574.
²³ *Ber.* **23** (1890), 1160.
²⁴ *J. Chem. Soc. Japan* **58** (1937), 926. *Chem. Abstracts* **32** (1938), 528.
²⁵ *J. Chem. Soc.* **99** (1911), 214.
²⁶ *J. Chem. Soc. Japan* **59** (1938), 359. *Chem. Abstracts* **32** (1938), 9060.

SUGGESTED ADDITIONAL LITERATURE

L. Bert, "Synthesis of Allyl and Propenyl Essential Oils. General Method," *Compt. rend.* **213** (1941), 873. *Chem. Abstracts* **37** (1943), 4060.

Yasuji Fujita and Takeo Yamashita, "Determination of Safrole in Essential Oils," *J. Chem. Soc. Japan* **63** (1942), 410. *Chem. Abstracts* **41** (1947), 3259.

Isosafrole

C₁₀H₁₀O₂

Mol. Weight 162.18

1,2-Methylenedioxy-4-propenylbenzene. Propenylpyrocatecholmethylene ether

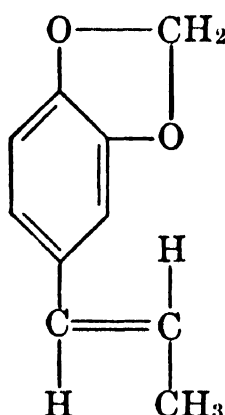

Theoretically, isosafrole can exist in the form of two geometrical isomers. In fact, years ago Hoering and Baum¹ identified in technical isosafrole two isomeric forms which they named α - and β -isosafrole. The latter largely predominates in the commercial product. According to Nagai,² the relationship of the isosafroles is a case of *cis-trans*-isomerism, the labile *cis*-form on warming being converted into the stable *trans*-form. Waterman and Priester³ came to the conclusion that the *cis*- or α -isosafrole reported in earlier literature is a mixture of safrole and *trans*-isosafrole, and that only the *trans*- or β -isosafrole isolate is homogeneous.

Occurrence.—Isosafrole is not as widely distributed in nature as safrole. It occurs probably in oil of ylang ylang.

Isolation.—By fractional distillation, and purification through the picrate.

Identification.—Isosafrole can be characterized by several methods. The variant melting points reported for several of these compounds may be due in part to the fact that the products retained a small percentage of unstable geometric isomers.

(1) By the preparation of derivatives:

(a) Bromoisosafrole dibromide. Underwood, Baril and Toone ⁴ suggested the following method:

Add 2.03 g. of bromine dropwise in the course of 15 min. to 0.41 g. of isosafrole dissolved in 2 cc. of carbon disulfide, and allow to stand for 24 hr. Grind the solid mass in a mortar with 3 cc. of cold alcohol and recrystallize from 5 cc. of petroleum ether. Needles m. 109°. Ciamician and Silber ⁵ reported m. 109°–110°, Pond, Erb and Ford ⁶ m. 110°–111°.

(b) Isosafrole picrate m. 74°–75° dark, red thick needles when crystallized from chloroform or alcohol, according to Baril and Megrđichian.⁷ Nagai ⁸ recorded 73.5°–74° for the *trans*- isomer and 68.5° for the *cis*- isomer.

(2) By oxidation:

Oxidizing 5 g. of isosafrole with 25 g. of potassium bichromate and 8 g. of sulfuric acid in 80 cc. of water, Ciamician and Silber ⁹ obtained about 4 g. of heliotropin (piperonal), as isolated through its sodium bisulfite addition compound.

Oxidation of isosafrole with potassium permanganate yields piperonylic acid. Imoto ¹⁰ described the following method:

Add 15 g. of isosafrole to 135 cc. of water, stir vigorously, and treat at 80°–90° with a 4% aqueous solution of potassium permanganate (69 g.) added dropwise during an hour. After the passage of another 30 min., filter and steam distill the unreacted products, and precipitate the organic acid with hydrochloric acid. The yield will be 11.9 g., or 79.5%, of piperonylic acid m. 226°–227.5°.

(3) The pseudonitrosite m. 133°, according to Monti and Dinelli,¹¹ prepared by the method of Angeli.¹²

Hudson and Robinson ¹³ reported that the reaction of 13 g. of isosafrole, 10 g. of maleic anhydride and 40 cc. of xylene refluxed 3 hr. gives 10 g. of adduct. Extract this derivative with chloroform, discarding the insoluble portion. The chloroform extract, as well as the xylene mother liquors, yields a naphthalenedicarboxylic acid anhydride m. 142°–143°; the phenylimide derived from the anhydride by heating with aniline melts at 243°.

Properties.—Isosafrole is a liquid with an anise-like odor.

As mentioned, Waterman and Priester ¹⁴ found that the *cis*- (or α -) isosafrole reported in the literature is a mixture of safrole and *trans*-isosafrole and that only the *trans*- (or β -) isosafrole is known with certainty.

The following properties have been reported by Waterman and Priester,¹⁵ Nagai,¹⁶ Eijkman,¹⁷ and Gildemeister and Hoffmann ¹⁸ for the stable *trans*- and the labile *cis*-isosafrole:

	<i>Trans</i> -	<i>Cis</i> -
m.	6.7°–6.8° ¹⁵	
b.	247°–248° ¹⁶	242°–243° ¹⁶
b ₄	105°–106° ¹⁸	
d ₄ ²⁰	1.122 ¹⁵	
d ₄ ¹⁵	1.1230–1.1235 ¹⁶	
d _{11.5}	1.126 ¹⁷	
n _D ²⁰	1.5782 ¹⁵	
n _D ¹⁵		1.5630–1.5632 ¹⁶

Conclusions relative to the configuration should not be drawn in terms of the von Auwers-Skita¹⁹ rule, which ordinarily requires the *cis*- compounds to be of higher specific gravity and refractive index, but of smaller molecular refractions. It has been shown that this rule cannot be applied to members of the styrene series. As regards isosafrole, the data on the *cis*- form are still too meager for conclusions to be drawn.

Isosafrole is soluble in organic solvents, alcohol, ether, benzene, etc. It is volatile with steam, and polymerizes under the influence of acids.

Use.—Isosafrole is used mainly for the manufacture of heliotropin.

- ¹ *Ber.* **42** (1909), 3076.
- ² *J. Coll. Eng. Tokyo Imp. Univ.* **11** (1921), 83.
- ³ *Rec. trav. chim.* **47** (1928), 851.
- ⁴ *J. Am. Chem. Soc.* **52** (1930), 4090.
- ⁵ *Ber.* **23** (1890), 1164.
- ⁶ *J. Am. Chem. Soc.* **24** (1902), 341.
- ⁷ *Ibid.* **58** (1936), 1415.
- ⁸ *J. Coll. Eng. Tokyo Imp. Univ.* **11** (1921), 108. *Chem. Abstracts* **16** (1922), 418.
- ⁹ *Ber.* **23** (1890), 1160.
- ¹⁰ *J. Soc. Chem. Ind. Japan* **37**, Suppl. (1934), 26.
- ¹¹ *Gazz. chim. ital.* **62** (1932), 370. Cf. Wallach and Mueller, *Liebigs Ann.* **332** (1904), 331.
- ¹² *Gazz. chim. ital.* **22**, II (1892), 335.
- ¹³ *J. Chem. Soc.* (1941), 715.
- ¹⁴ *Rec. trav. chim.* **47** (1928), 851, 1036; **48** (1929), 1272.
- ¹⁵ *Ibid.* **47** (1928), 851, 1033; **48** (1929), 1272.
- ¹⁶ *J. Coll. Eng. Tokyo Imp. Univ.* **11** (1921), 108. *Chem. Abstracts* **16** (1922), 418.
- ¹⁷ *Ber.* **23** (1890), 859.
- ¹⁸ "Die Ätherischen Öle," 3d Ed., Vol. I, 615.
- ¹⁹ *Liebigs Ann.* **420** (1920), 91. *Ber.* **53** (1920), 1792; **68** (1935), 1346.

SUGGESTED ADDITIONAL LITERATURE

Matsuji Takebayashi, "Reaction of Isosafrole with Hydrogen Halides. Consideration of the Dimerization of Isosafrole," *J. Chem. Soc. Japan* **64** (1943), 1363. *Chem. Abstracts* **41** (1947), 3774.

Matsuji Takebayashi, "Polymerization of Isosafrole. Synthesis of Diisosafrole with Metallic Salts," *J. Chem. Soc. Japan* **65** (1944), 582. *Chem. Abstracts* **41** (1947), 3774.

Myristicin

$C_{11}H_{12}O_3$

Mol. Weight 192.21

1,2-Methylenedioxy-6-methoxy-4-allylbenzene.

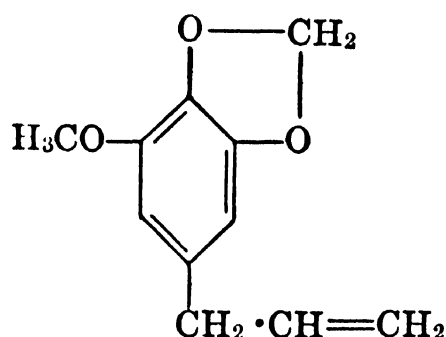

Occurrence.—Myristicin occurs in oils of nutmeg and mace, also in French parsley and dill oil. This phenol ether must not be confused with the deposit

occasionally crystallizing from old nutmeg oils on standing. In the old literature this deposit was called "myristicin," but Flückiger ¹ showed it to consist of myristic acid m. 54°.

Huzita ² has recently detected myristicin in orthodon oils.

Isolation.—By fractional distillation.

Identification.—Myristicin can be characterized by the following methods:

(1) On treatment with bromine, myristicin, according to Gildemeister and Hoffmann, ³ yields dibromomyristicin dibromide $(C_3H_5Br_2) \cdot C_6Br_2(O_2CH_2) \cdot (OCH_3)$, m. 130° (cf. also Windisch, ⁴ and Trikojus and White ⁵).

(2) According to Thoms, ⁶ myristicin, on oxidation with permanganate, yields myristicinaldehyde m. 130°, and myristicinic acid m. 208°–210°. The same products are obtained by oxidation of isomyristicin (see below). (Cf. Baker, Montgomery and Smith, ⁷ and Baker, Penfold and Simonsen. ⁸)

Properties.—Myristicin is an oil of slightly aromatic odor. It does not congeal at low temperature. The following properties have been reported by Power and Salway, ⁹ Thoms, ¹⁰ and Trikojus and White: ¹¹

b ₄₀	171°–173° ⁹	d ₂₀ ²⁰	1.1437 ⁹
b ₁₅	149.5° ¹⁰	d ₁₉	1.1425 ¹⁰
b _{0.2}	95°–97° ¹¹	n _D ^{45.5}	1.52927 ⁹
		n _D ²⁰	1.54032 ⁹

On boiling with alcoholic potassium hydroxide or on treatment with metallic sodium, the liquid myristicin is converted into solid isomyristicin, the allyl group being rearranged into the propenyl group. Isomyristicin occurs in oil of mace and dill herb.

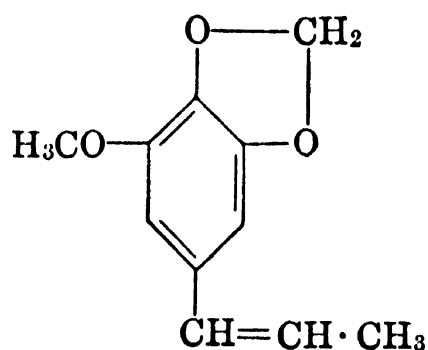

Isomyristicin

1,2-Methylenedioxy-6-methoxy-4-propenylbenzene

Power and Salway ¹² reported the following properties for isomyristicin:

m.	44°
b ₁₈	166°
n _D ^{45.5}	1.56551

Isomyristicin can be characterized by the preparation of a dibromide m. 109°, and of dibromoisomyristicin dibromide m. 156° (cf. also Trikojus and White ¹³).

Use.—Myristicin is not used in our industries.

- ¹ *Pharm. J.* III, 5 (1874), 136.
- ² *J. Chem. Soc. Japan* 61 (1940), 729. *Chem. Abstracts* 36 (1942), 6753.
- ³ "Die Ätherischen Öle," 3d Ed., Vol. I, 616.
- ⁴ *Merck's Jahresber.* 47 (1933), 56.
- ⁵ *Nature* 144 (1939), 1016.
- ⁶ *Ber.* 36 (1903), 3446.
- ⁷ *J. Chem. Soc.* (1932), 1283.
- ⁸ *Ibid.* (1939), 439.
- ⁹ *Ibid.* 91 (1907), 2054.
- ¹⁰ *Ber.* 36 (1903), 3447.
- ¹¹ *Nature* 144 (1939), 1016.
- ¹² *J. Chem. Soc.* 91 (1907), 2054.
- ¹³ *Nature* 144 (1939), 1016.

Croweacin

$C_{11}H_{12}O_3$

Mol. Weight 192.21

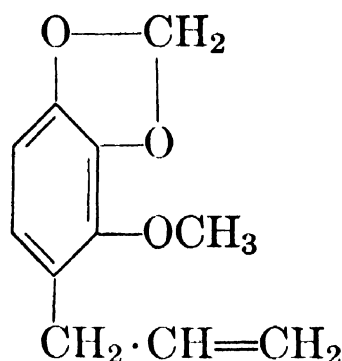

This phenol ether was first described by Penfold and Morrison.¹ Some years later, Penfold and collaborators² established for croweacin the structural formula pictured above (1,2-methylenedioxy-3-methoxy-4-allylbenzene).

Occurrence.—According to Penfold and Morrison,³ croweacin forms the main constituent (about 90 per cent) of the oil distilled from the leaves and terminal branchlets of *Eriostemon crowei* F. Mull. (fam. *Rutaceae*), (*Crowei saligna*).

Isolation.—By fractional distillation, which must be repeatedly carried out as the phenol ether, according to Penfold and Morrison,⁴ is not easily freed from accompanying laevo- and dextrorotatory substances possessing closely related boiling points.

Identification.—On treatment with bromine, croweacin yields dibromocroweacin dibromide m. 108°.

Oxidation of croweacin by potassium permanganate, according to Baker, Penfold and Simonsen,⁵ yields a glycol m. 90°–91° (recrystallization first from ligroine and then from ether).

Properties.—For natural croweacin Baker, Penfold and Simonsen⁶ reported:

b_{10}	129°–131°
d_{15}^{15}	1.1346
$n_D^{19.5}$	1.5346

Penfold and Morrison⁷ had earlier observed constants of the same order and reported b_{766} 256°–258°.

Refluxed for 68 hr. with 16 g. of potassium hydroxide in 60 cc. of ethyl alcohol, the natural croweacin is converted to isocroweacin (2-methoxy-3,4-methylenedioxypropenylbenzene), which after purification by the picrate had these properties: b_{12} 145° – 147° , n_D^{20} 1.5675, picrate m. 75° – 76° (garnet red crystals). The natural croweacin does not form a picrate.⁶ The isocroweacin behaves in an unexpected manner toward bromine in acetic acid at room temperature, and yields 1,2,3-tribromo-4-methoxy-5,6-methylenedioxybenzene with complete loss of the propenyl side chain.

Use.—Croweacin is not used in our industries.

¹ *J. Proc. Roy. Soc. N. S. Wales* **56** (1922), 227.

² *J. Chem. Soc.* (1938), 756; (1939), 439.

³ *J. Proc. Roy. Soc. N. S. Wales* **56** (1922), 228.

⁴ *Ibid.*

⁵ *J. Chem. Soc.* (1939), 441.

⁶ *Ibid.*

⁷ *J. Proc. Roy. Soc. N. S. Wales* **56** (1922), 229.

Elemicin

$C_{12}H_{16}O_3$

Mol. Weight 208.25

1,2,6-Trimethoxy-4-allylbenzene

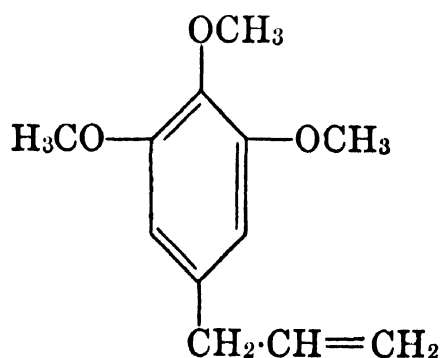

Occurrence.—Elemicin is the main constituent of Manila elemi oil after which it has been named by Semmler.¹ Elemicin occurs also in a few other volatile oils.

Isolation.—By fractional distillation. Semmler² purified the fraction b. 277° – 280° of elemi oil by boiling with formic acid whereby the allyl compound remains unchanged and the propenyl compounds are destroyed.

Identification.—Elemicin can be characterized by the following methods:

(1) On oxidation with potassium permanganate in acetone solution, elemicin yields trimethylgallic acid m. 169° , b_{10} 225° – 227° . The same end product is formed on oxidation of isoelemicin with permanganate.

(2) By rearrangement and preparation of isoelemicin dibromide m. 88° – 89° , according to Gildemeister and Hoffmann.³

(3) Ozonization with 1% ozone in ethyl acetate and decomposition of the ozonide in a reducing atmosphere gave 75% of 3,4,5-(CH_3O) $_3\text{C}_6\text{H}_2\text{CH}\cdot\text{CHO}$, which was isolated by means of its bisulfite compound. The aldehyde regenerated from this addition compound yields an oxime m. 67° , and a semicarbazone m. 191° , according to Hahn and Wassmuth.⁴

Properties.—The following properties of elemicin have been reported by Gildemeister and Hoffmann,⁵ and Hahn and Wassmuth:⁶

b ₁₇	152°–156° ⁶	d ₂₀	1.063 ⁵
b ₁₀	144°–147° ⁵	n _D	1.52848 ⁵

On boiling with alcoholic potassium hydroxide or on treatment with metallic sodium, elemicin is converted to isoelemicin (1,2,6-trimethoxy-4-propenylbenzene), an isomer of asarone.

Gildemeister and Hoffmann⁷ reported these properties of isoelemicin:

b ₁₀	153°–156°
d ₂₀	1.073
n _D	1.54679

Use.—Elemicin, as such, is not used in our industries.

¹ *Ber.* **41** (1908), 1768, 1918, 2183, 2556.

² *Ibid.* **41** (1908), 1918, 2185.

³ "Die Ätherischen Öle," 3d Ed., Vol. I, 618.

⁴ *Ber.* **67B** (1934), 696.

⁵ "Die Ätherischen Öle," 3d Ed., Vol. I, 617.

⁶ *Ber.* **67B** (1934), 704.

⁷ "Die Ätherischen Öle," 3d Ed., Vol. I, 618.

SUGGESTED ADDITIONAL LITERATURE

L. Bert, "Synthesis of Allyl and Propenyl Essential Oils. General Method," *Compt. rend.* **213** (1941), 873. *Chem. Abstracts* **37** (1943), 4060.

Asarone

C₁₂H₁₆O₃

Mol. Weight 208.25

1,2,5-Trimethoxy-4-propenylbenzene

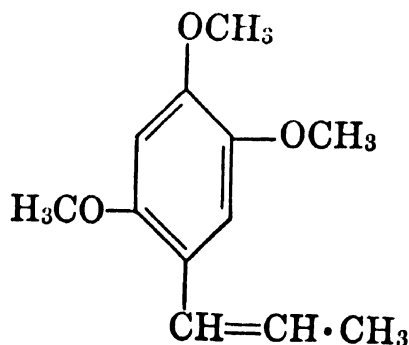

Occurrence.—Asarone occurs in oil of *Asarum arifolium*, *A. europaeum*, *calamus*, *matico*, and a few other volatile oils.

The isolate from the oil in roots of *Acorus calamus* Linn. was shown by Rao and Subramaniam,¹ however, to be β -asarone and differs from the ordinary asarone as do *cis-trans*-isomers.

Oils containing a high percentage of asarone separate this phenol ether on prolonged standing.

Isolation.—By fractional distillation and cooling of the asarone fraction to a low temperature, followed by recrystallization.

Identification.—Ordinary asarone can be characterized by the following methods (where the properties of the isomeric β -asarone are known they are described):

(1) According to Gildemeister and Hoffmann,² by the preparation of the dibromide m. 86°. On treatment with sodium methylate in the cold, this dibromide yields a compound $(\text{CH}_3\text{O})_3 \cdot \text{C}_6\text{H}_2 \cdot \text{CH}(\text{OCH}_3) \cdot \text{CHBr} \cdot \text{CH}_3$, m. 77.5°.

Rao and Subramaniam³ reported the dibromide of β -asarone as a liquid and the melting point of that of asarone as 82°–83°.

(2) By the action of chromic acid, asarone is oxidized to asaryl aldehyde m. 114°, while on oxidation with potassium permanganate, asarone forms asaryl aldehyde and asaronic acid m. 144° (trimethoxybenzoic acid) (Gildemeister and Hoffmann).

(3) Picrate m. 81°–82°, by Bruni and Tornani.⁴

(4) Compound with trinitrobenzene $\text{C}_{12}\text{H}_{16}\text{O}_3 + \text{C}_6\text{H}_3\text{O}_6\text{N}_3$, m. 77°–78°, according to Sudborough and Beard.⁵

(5) According to Bruckner,⁶ asarone in ether reacts with aqueous sodium nitrite previously acidified with 20% sulfuric acid to give an 80% yield of asarone pseudo-nitrosite $(\text{C}_{12}\text{H}_{16}\text{O}_6\text{N}_2)_2$, yellow, m. 130° (dec.). This compound reacts further with 8% alcoholic potassium hydroxide to yield β -nitroasarone m. 101° which exists as both a red and yellow form.

Rao and Subramaniam⁷ reported that asarone and β -asarone both yield the same ψ -nitrosite.

Properties.—In pure form asarone is odorless and tasteless. The following properties of the *trans*- and *cis*- isomers, asarone and β -asarone, have been reported by Rao and Subramaniam:⁸

	m.	b_{12}	d_{30}^{30}	n_D^{20}	$[\text{R}_L]_D$
Asarone	62°–63°	167°–168°	1.112	1.5683	62.7
β -Asarone	...	162°–163°	1.082	1.5552	62.2

No deduction as to configuration can safely be drawn, however, from these figures as the rule of von Auwers-Skita⁹ is not strictly applicable in the styrene series.

These isomers are interconvertible by the action of alkali, according to the above authors.

Asarone is slightly soluble in hot water, readily soluble in alcohol, ether and chloroform.

Use.—Asarone, as such, is not used in our industries, although "asarone oil" in which it is contained has, according to Orient,¹⁰ found some use as an abortifacient.

¹ *J. Chem. Soc.* (1937), 1338.

² "Die Ätherischen Öle," 3d Ed., Vol. I, 618.

³ *J. Chem. Soc.* (1937), 1338.

⁴ *Atti accad. Lincei* [5], **13**, II (1904), 186.

⁵ *J. Chem. Soc.* **99** (1911), 214.

⁶ *J. prakt. Chem.* **138** (1933), 271; **148** (1937), 5.

⁷ *J. Chem. Soc.* (1937), 1338.

⁸ *Ibid.*, 1339.

⁹ *Liebigs Ann.* **420** (1920), 91. *Ber.* **53** (1920), 1792; **68** (1935), 1346.

¹⁰ *Pharm. Monatsh.* **11** (1930), 174. *Chem. Abstracts* **25** (1931), 169.

Diasarone

(C₁₂H₁₆O₃)₂

Mol. Weight 416.5

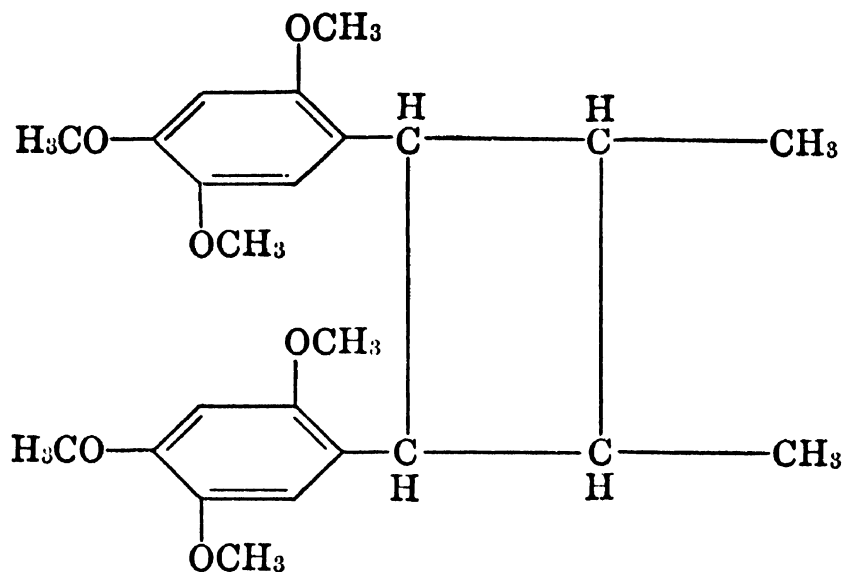

Gerö¹ found in the volatile oil derived from the roots of Hungarian wild hazelnut, *Asarum europaeum* L. (fam. *Aristolochiaceae*), a phenol ether, viz., diasarone (C₁₂H₁₆O₃)₂, m. 99°. Haraszti and Széki² reported for synthetic diasarone a melting point of 101.5°. The work of these investigators suggests the above-pictured formula as a symmetrical dimeride of asarone.

Diasarone was identified by oxidation to asaronic acid m. 144°.

¹ *Riechstoff Ind.* **3** (1928), 176. *Ber. Schimmel & Co.* (1929), 49. *Chem. Abstracts* **24** (1930), 2235.

² *Liebigs Ann.* **507** (1933), 201. Cf. *Ber.* **39** (1906), 2422.

Apiole *

C₁₂H₁₄O₄

Mol. Weight 222.23

1,2-Methylenedioxy-3,6-dimethoxy-4-allylbenzene.

“Parsley camphor”

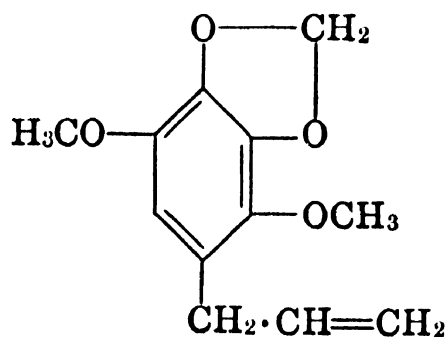

The constitution of apiole was established through the investigations of Ciamician and Silber,¹ and Thoms,² and confirmed in recent work of Baker and Savage³ who completed a synthesis of this product and identified it with the natural isolate.

* The pure chemical is not to be confused with the commercial “green oily liquid” sometimes described as apiole. For a discussion of this compound, see Walmsley, *Pharm. J.* **121** (1928), 89. *Chemist Druggist* **109** (1928), 127. *Quart. J. Pharm.* **1** (1928), 388.

Occurrence.—Apiole occurs in parsley seed oil and in a few other volatile oils.

Isolation.—By cooling of the oil to a low temperature, and recrystallization from alcohol and petroleum ether. Separable from the isomeric isoapiole by means of their mercury salts (cf. Balbiano ⁴).

Identification.—Apiole can be characterized by several methods:

(1) By the preparation of apiole tribromide (bromoapiole dibromide) $(\text{CH}_3\text{O})_2\text{C}_6\text{Br}(\text{O}_2\text{CH}_2) \cdot \text{C}_3\text{H}_5\text{Br}_2$, m. $80^\circ\text{--}80.5^\circ$, as recorded by Baker and Savage, ⁵ from the reaction of excess bromine in carbon disulfide on natural apiole.

(2) By oxidation:

On oxidation with potassium permanganate, apiole as well as isoapiole yields apiolaldehyde m. 102° and apiolic acid m. 173° . Fabinyi and Széki ⁶ found that apiolaldehyde is obtained most conveniently by oxidation of isoapiole with ethyl nitrite. Apiolaldehyde forms a characteristic *p*-nitrophenylhydrazone m. $228^\circ\text{--}229^\circ$, according to Quilico and Freri. ⁷

(3) Vignoli ⁸ suggested a suitable method for the quantitative determination of apiole, by means of bromination and titration of excess halogen by means of bisulfite.

(4) The following qualitative colorimetric test is recommended by Ionesco-Matiu and Popesco: ⁹

To 1 cc. of the alcoholic solution add 5 drops of a 2.5% solution of phosphomolybdic acid in dilute alcohol. Then add 0.5 cc. of concentrated sulfuric acid and shake. A deep blue-green color changing to orange-red on heating indicates apiole.

Properties.—Apiole crystallizes in the form of long colorless needles. The odor is faint, reminiscent of parsley.

The following properties have been reported by Ciamician and Silber, ¹⁰ Vignoli, ¹¹ Gildemeister and Hoffmann, ¹² Eykman, ¹³ and Baker and Savage: ¹⁴

m.	$28.5^\circ\text{--}29^\circ$ ¹⁴ (synthetic)	d_{15}^{15}	1.1788 ¹² (superfused)
	28° ¹¹ (natural)	d_{14}	1.176 ¹³
b.	292° ¹¹	n_D^{14}	1.5380 ¹³ (liquid)
b_{34}	179° ¹⁰		

Apiole has been reported by Volochneva ¹⁵ as polymorphic with an unstable form m. $18^\circ\text{--}19^\circ$.

Apiole is almost insoluble in water, soluble in alcohol, ether or in fatty oils.

On boiling with alcoholic potassium hydroxide, apiole is converted into isoapiole m. $55^\circ\text{--}56^\circ$, which yields a monobromide m. 51° , a dibromide m. 75° , and a tribromide m. 120° .

Apiole as well as isoapiole reacts with nitrous acid.

Use.—Apiole, as such, is not used in our industries, although it is reported as a substance of considerable physiological power but of questionable therapeutic value (cf. U. S. Dispensatory ¹⁶).

¹ *Ber.* **21** (1888), 913, 1621; **22** (1889), 2481; **23** (1890), 2283.

² *Ber.* **36** (1903), 1714.

³ *J. Chem. Soc.* (1938), 1602.

⁴ *Ber.* **42** (1909), 1506. *Atti accad. Lincei* [5], **18**, I (1909), 375.

- ⁵ *J. Chem. Soc.* (1938), 1607. Cf. Ginsberg, *Ber.* **21** (1888), 2514.
⁶ *Ber.* **50** (1917), 1335. Cf. Baker and Savage, *J. Chem. Soc.* (1938), 1606.
⁷ *Gazz. chim. ital.* **58** (1928), 380.
⁸ *Bull. sci. pharmacol.* **40** (1933), 344. *Chem. Abstracts* **27** (1933), 4628.
⁹ *Bull. soc. chim. biol.* **17** (1935), 671. *Chem. Abstracts* **29** (1935), 5222.
¹⁰ *Ber.* **21** (1888), 1622.
¹¹ *Bull. sci. pharmacol.* **40** (1933), 344. *Chem. Abstracts* **27** (1933), 4628.
¹² "Die Ätherischen Öle," 3d Ed., Vol. I, 619.
¹³ *Ber.* **23** (1890), 862.
¹⁴ *J. Chem. Soc.* (1938), 1607.
¹⁵ *J. Russ. Phys. Chem. Soc.* **62** (1930), 77. *Chem. Abstracts* **24** (1930), 4679.
¹⁶ 24th Ed., Lippincott (1947), 1543.

SUGGESTED ADDITIONAL LITERATURE

I. Payen, "Detection and Determination of Apiole in Viscera," *Ann. méd. légale criminol. police sci.* **15** (1935), 59. *Chem. Abstracts* **29** (1935), 4694.

Dillapiole

C₁₂H₁₄O₄

Mol. Weight 222.23

1,2-Methylenedioxy-5,6-dimethoxy-4-allylbenzene

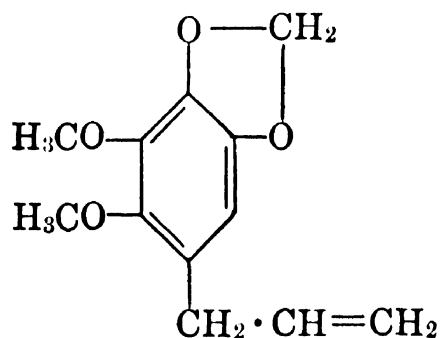

The constitution of dillapiole was established by Thoms,¹ and the complete synthesis effected by Baker, Jukes and Subrahmanyam.²

Occurrence.—Dillapiole occurs in East Indian, Japanese, and Spanish dill oils and in oil of *Crithmum maritimum*. Spoelstra³ reported the compound in Bamba oil ("laurel oil"); Kariyone and Teramoto⁴ identified it in *Ligusticum scoticum* and Huzita⁵ detected 65 per cent in *Orthodon formosanum* Kudo; it also occurs in a few other volatile oils.

Isolation.—By fractional distillation.

Identification.—Dillapiole can be characterized by several methods:

(1) On treatment with excess bromine, dillapiole forms a monobromoapiole dibromide C₁₂H₁₃Br₃O₄, colorless prisms which melt at 107°, according to Baker, Jukes and Subrahmanyam.⁶

(2) On treatment with alcoholic potassium hydroxide, dillapiole is converted into dillisoapiole m. 44°, b. 296° (dec.). Delépine and Longuet⁷ prepared the tribromide of dillisoapiole m. 115°. Spoelstra⁸ reported the picrate as m. 81.5°.

(3) On oxidation with alkaline potassium permanganate solution, dillapiole, according to Gildemeister and Hoffmann,⁹ yields dillapiolaldehyde C₁₀H₁₀O₅, m. 75°, and dillapiolic acid C₁₀H₁₀O₆, m. 151°–152° (144° according to Kariyone and Teramoto¹⁰).

Properties.—Dillapiole is a viscid, almost odorless oil. The following properties have been reported by Ciamician and Silber,¹¹ Spoelstra,¹² Baker, Jukes and Subrahmanyam,¹³ and Delépine:¹⁴

b.	285° ¹¹	d ₁₅ ¹⁵	1.1598 ¹²
b ₁₆	172°–173° ¹³	d ₄ ¹³	1.1644 ¹⁴
b ₁₁	162° ¹¹	n _D ²⁵	1.52778 ¹⁴
		n _D ¹⁷	1.5305 ¹²

Use.—Dillapiole, as such, is not used in our industries.

¹ *Arch. Pharm.* **242** (1904), 344.

² *J. Chem. Soc.* (1934), 1681.

³ *Rec. trav. chim.* **48** (1929), 372.

⁴ *J. Pharm. Soc. Japan* **59** (1939), 313. *Chem. Abstracts* **33** (1939), 7959.

⁵ *J. Chem. Soc. Japan* **61** (1940), 729. *Chem. Abstracts* **36** (1942), 6753.

⁶ *J. Chem. Soc.* (1934), 1683. Cf. Kariyone and Teramoto, *J. Pharm. Soc. Japan* **59** (1939), 313; *Chem. Abstracts* **33** (1939), 7959. Spoelstra, *Rec. trav. chim.* **48** (1929), 372. Ciamician and Silber, *Ber.* **29** (1896), 1800.

⁷ *Bull. soc. chim.* IV, **39** (1926), 1022.

⁸ *Rec. trav. chim.* **48** (1929), 373.

⁹ "Die Ätherischen Öle," 3d Ed., Vol. I, 620.

¹⁰ *J. Pharm. Soc. Japan* **59** (1939), 313. *Chem. Abstracts* **33** (1939), 7959.

¹¹ *Gazz. chim. ital.* II, **26** (1896), 293. *Ber.* **29** (1896), 1799.

¹² *Rec. trav. chim.* **48** (1929), 373.

¹³ *J. Chem. Soc.* (1934), 1682. Cf. Kariyone and Teramoto, *J. Pharm. Soc. Japan* **59** (1939), 313; *Chem. Abstracts* **33** (1939), 7959. Spoelstra, *Rec. trav. chim.* **48** (1929), 372. Ciamician and Silber, *Ber.* **29** (1896), 1800.

¹⁴ *Compt. rend.* **149** (1909), 216.

Calamol



Mol. Weight 208.25

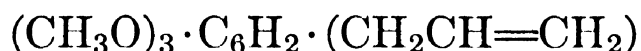

Occurrence.—Quadrat-i-Khuda, Mukherjee and Ghosh¹ isolated from the rhizomes of *Acorus calamus* an oily substance of the empirical formula $\text{C}_{12}\text{H}_{16}\text{O}_3$ which they demonstrated to be an allyltrimethoxybenzene.

Isolation.—The essential oil from the Indian variety "ghorebacha" is fractionally distilled several times, saving the cut b₅ 153°–154° which amounts to 7–8% of the total steam distilled oil.

Identification.—Oxidation with alkaline permanganate yields calamonic acid m. 143°.

Properties.—The isolate from Indian calamus oil possesses these properties:

b ₅	153°–154°	[R _L] _D Found	61.9
d ₄ ^{30.1}	1.07021	Calc.	58.5
n _D ^{30.1}	1.55012		

Calamol is a colorless mobile liquid with a strong characteristic and rather pleasant aromatic odor.

When refluxed with alcoholic potassium hydroxide, calamol is isomerized to an isocalamol ($C_9H_{11}O_3 \cdot CH=CH \cdot CH_3$, b_2 133° , $d_4^{31.5}$ 1.07261, $n_D^{31.5}$ 1.55229), which yields a trimethoxybenzoic acid identical with that obtained from calamol upon oxidation with alkaline permanganate.

Calamol forms a dihydroderivative when catalytically reduced: $C_{12}H_{18}O_3$, b_2 124° , $d_4^{31.2}$ 1.03109, $n_D^{31.2}$ 1.51219.

Demethylation shows the existence of three methoxy groups.

Use.—Calamol, as such, is not used in our industries.

¹ *J. Indian Chem. Soc.* **16** (1939), 583. *Chem. Abstracts* **34** (1940), 2531.

Allyltetramethoxybenzene

$C_{13}H_{18}O_4$

Mol. Weight 238.27

1-2,3,6-Tetramethoxy-4-allylbenzene

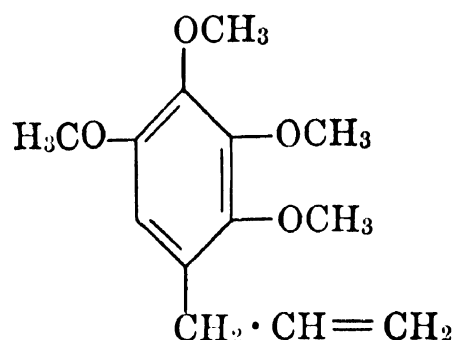

Occurrence.—Thoms ¹ isolated this phenol ether from French parsley seed oil.

Isolation.—By fractional distillation, cooling of the corresponding fraction to a low temperature, and recrystallization.

Identification.—Allyltetramethoxybenzene can be characterized by its oxidation product. For this purpose Bignami and Testoni ² used potassium permanganate and obtained tetramethoxybenzoic acid which crystallizes in the form of long needles m. 87° .

Properties.—Thoms ³ reported these properties:

m.	25°
d_{25}	1.087
n_D^{25}	1.51462

Use.—Allyltetramethoxybenzene is not used in our industries.

¹ *Ber.* **41** (1908), 2761.

² *Gazz. chim. ital.* **30**, I (1900), 246.

³ *Ber.* **41** (1908), 2761.

Diosphenol

(Buchucamphor)

 $C_{10}H_{16}O_2$

Mol. Weight 168.23

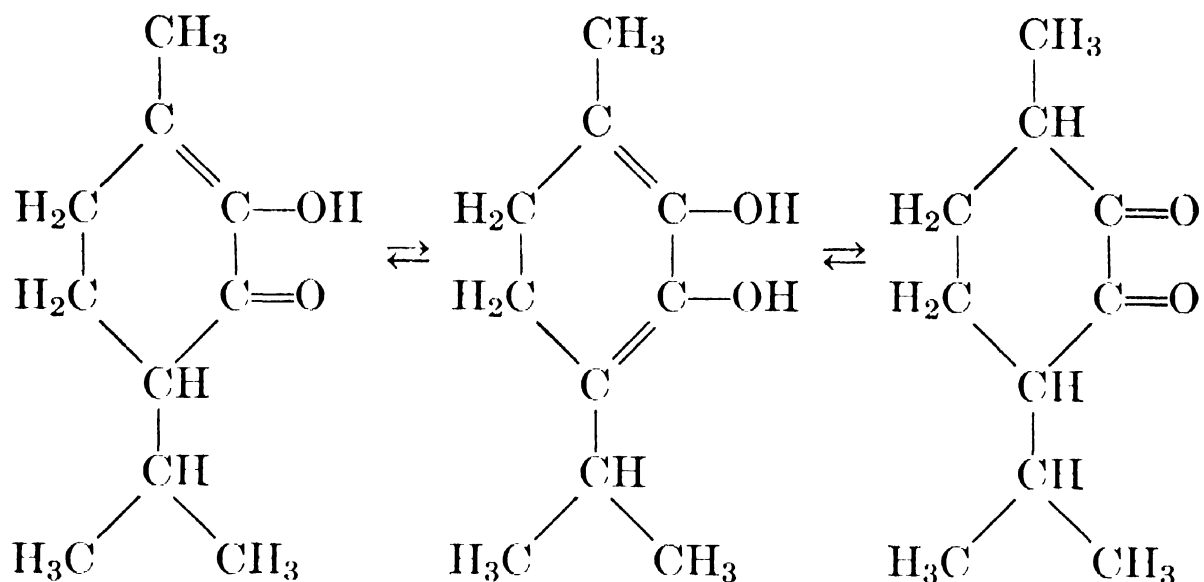

Occurrence.—Diosphenol is the main constituent (17–30 per cent) of the oils distilled from the leaves (buchu leaves) of various *Barosma* species, especially *Barosma betulina* Bartl. Some of these oils partly crystallize at room temperature, the crystals being diosphenol.

Isolation.—Diosphenol may be separated from *Barosma betulina* oil by cooling the oil repeatedly to -20° and by fractionating. Or diosphenol can be isolated from *Barosma* oils by shaking with dilute alkali solutions and by acidifying the solution. However, in this case care has to be exercised because part of the diosphenol will dissolve in the ether if, previous to acidification, the alkali solution is extracted with ether.

Identification.—Diosphenol can be characterized by its m. 83° , by the fact that it reduces both Fehling's and ammoniacal silver solutions, that it gives an intense green coloration with ferric chloride, and by the preparation of several derivatives as indicated below. Its reaction and derivatives would seem to confirm the formula of a cyclic hydrogenated keto-phenol originally assigned to this terpenic derivative. However, recent physicochemical studies have led a number of investigators (Straneo,¹ and Gillam, Lynas-Gray, Penfold and Simonsen²) to attribute a diphenolic structure to buchucamphor. Such a structure conforms to the reactions discussed above.

(1) Phenylurethane m. 113° (Asahina and Mituhori³).

(2) Monoxime m. 125° which forms very slowly (Semmler and McKenzie⁴).

(3) When heated with alcoholic alkali in a sealed tube to 150° – 160° , diosphenol forms a hydroxy acid which crystallizes from water in needles m. 94° (Semmler and McKenzie).

Properties.—Diosphenol possesses a peculiar mint-like odor. It forms optically inactive, monoclinic crystals m. 83° , b_{10} 109° – 110° . Von Auwers⁵ reported these properties for the fused ketone:

m.	83°
$d_4^{99.2}$	0.9524
$n_D^{99.8}$	1.46070

Diosphenol is very readily attacked by oxidizing agents.

Use.—Because it is not readily available, diosphenol has not found any noteworthy use in our industries.

¹ *Gazz. chim. ital.* **70** (1940), 27; **71** (1941), 646.

² *J. Chem. Soc.* (1941), 60.

³ *J. Pharm. Soc. Japan* **482** (1922), 255. *Chem. Abstracts* **16** (1922), 2502.

⁴ *Ber.* **39** (1906), 1158.

⁵ *Ber.* **57** (1924), 1106.

Phloracetophenone Dimethyl Ether

(Xanthoxylin)

$C_{10}H_{12}O_4$

Mol. Weight 196.20

2-Hydroxy-4,6-dimethoxyacetophenone

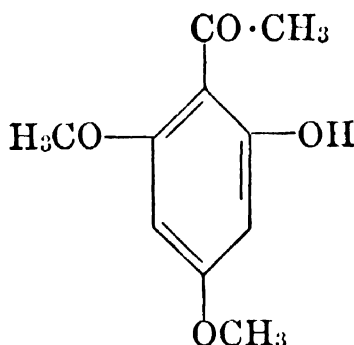

Occurrence.—This compound occurs in the oil of *Blumea balsamifera* and in a few other volatile oils. Penfold¹ found it in the oil derived from the leaves and twigs of *Geijera parviflora* Lindley var. A (fam. *Rutaceae*), and in the oil derived from *Geijera salicifolia* Schott. Sonn² reported the presence of phloracetophenone dimethyl ether in the volatile oils of *Xanthorrhoea*. Finlayson³ in the past had described this compound as “hydroxypeonol.” This ether is likewise found in literature under the name of “brevifolin,” having been isolated from *Artemisia brevifolia* (cf. Communication from Laboratories T. & H. Smith Ltd.⁴).

Isolation.—(1) By cooling of the oil, and crystallization.

(2) By fractional distillation.

(3) Due to its phenolic nature, this compound can be extracted from volatile oils by treatment with a dilute aqueous sodium hydroxide solution, and by acidification of the separated aqueous layer whereby phloracetophenone dimethyl ether precipitates as a solid, yellowish substance.

Identification.—Phloracetophenone dimethyl ether may be characterized by several methods:

By the preparation of derivatives, as recorded by Gildemeister and Hoffmann:⁵

(1) Oxime m. 108°–110°.

(2) Monobromide m. 187°.

(3) Acetyl compound m. 106°–107°.

(4) Methyl ether m. 103°.

(5) Condensation with benzaldehyde yields 2-hydroxy-4,6-dimethoxychalcone m. 91° – 92° (cf. also Kimura ⁶).

Shinoda and Sato ⁷ obtained a meconinic acid derivative m. 175° by alkaline condensation with opianic acid; the derived monomethyl ether melted at 144° – 145° , and the dimethyl ether at 155° – 156° .

Gulati and Venkataraman ⁸ prepared the benzoyl derivative m. 91° by the action of benzoyl chloride in pyridine upon 2-hydroxy-4,6-dimethoxyacetophenone.

Properties.—On recrystallization from benzene or petroleum ether phloracetophenone dimethyl ether forms colorless crystals m. 82° – 83° ; b. 307° (Barger and Easton ⁹), b_{20} 185° (Sonn ¹⁰).

Because of the phenolic and ketonic groups contained in its molecule, this phenol ether reacts as a phenol as well as a ketone. However, according to Sonn and Winzer,¹¹ these functional groups may not always react smoothly as this compound may display a tautomeric structure under certain conditions.

Use.—Phloracetophenone dimethyl ether is not used in our industries.

¹ *J. Proc. Roy. Soc. N. S. Wales* **64** (1930), 264.

² *Ber.* **61A** (1928), 2300.

³ *J. Chem. Soc.* (1926), 2763.

⁴ *Chemist Druggist* **112** (1930), 7. *Pharm. J.* **123** (1929), 604, 611.

⁵ "Die Ätherischen Öle," 3d Ed., Vol. I, 623.

⁶ *J. Pharm. Soc. Japan* **60**, 145, *Abstracts* (in German) 51 (1940). *Chem. Abstracts* **34** (1940), 4063.

⁷ *J. Pharm. Soc. Japan* No. 548 (1927), 850. *Chem. Abstracts* **22** (1928), 767.

⁸ *J. Chem. Soc.* (1936), 268.

⁹ See Communication from Laboratories, T. & H. Smith Ltd., *Chemist Druggist* **112** (1930), 7.

¹⁰ *Ber.* **61A** (1928), 2301.

¹¹ *Ibid.*, 2303.

Eugenone

$C_{13}H_{16}O_5$

Mol. Weight 252.26

2,4,6-Trimethoxybenzoylacetone

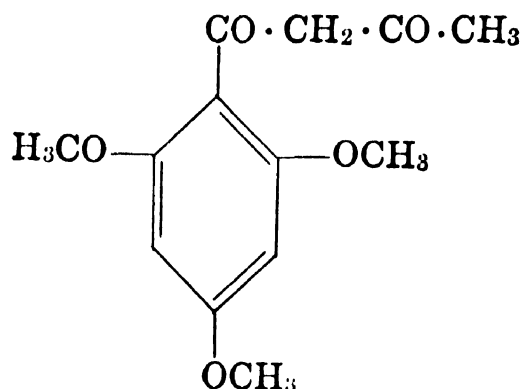

Occurrence.—Meijer ¹ first observed this compound in the oil extracted with petroleum ether from the dried buds (cloves) of the variety of tree *Eugenia caryophyllata* Thunb. which grows *wild* in the Moluccas. Curiously enough, the oil from the cloves of this wild growing tree contains no eugenol.

Meijer ² expressed the opinion that eugenone is 2,6-dimethoxy-4-hydroxyacetophenone. Schmid,³ however, demonstrated that this could not be the

case, since the melting point of the last-named compound, synthesized years ago by Canter, Curd and Robertson,⁴ differed considerably from that of eugenone.

More recently, Meijer and Schmid,⁵ working in collaboration, found that eugenone is actually 2,4,6-trimethoxybenzoylacetone, the first member of the benzoylacetone series observed in nature.

Isolation.—By recrystallization of the extract of the cloves (see above), and by sublimation of the crude eugenone m. 93°–96° *in* (high) *vacuo* b_{0.008} 100°–105°.

Identification.—By the preparation of the *p*-nitrophenylhydrazone m. 221°–222°.

Properties.—Odorless and colorless needles m. 97°–98°.

On treatment with alcoholic ferric chloride, eugenone develops a dark red color.

Use.—Eugenone, as such, is not used in our industries.

¹ *Rec. trav. chim.* **65** (1946), 843.

² *Ibid.*

³ *Helv. Chim. Acta* **30** (1947), 1663.

⁴ *J. Chem. Soc.* (1931), 1245.

⁵ *Helv. Chim. Acta* **31** (1948), 748.

Baeckeol

C₁₃H₁₈O₄

Mol. Weight 238.27

2-Hydroxy-4,6-dimethoxy-3-methyl-isobutyrophenone

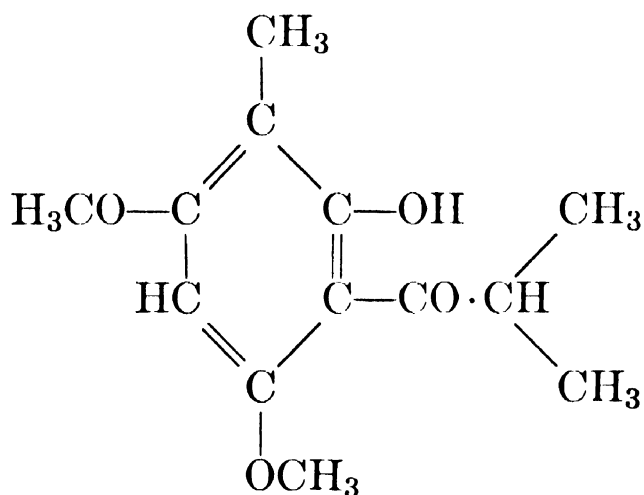

The phenol C₁₃H₁₈O₄, first described by Penfold and Morrison,¹ was later examined by Penfold and Simonsen² who suggested a tentative structural formula and the name baeckeol. Ramage and Stowe³ synthesized methyl phloroisobutyrophenone dimethyl ether and found it to be identical with baeckeol. A second synthesis was offered by Hems and Todd.⁴

Occurrence.—Baeckeol occurs in the oils of *Baeckea crenulata* and *Darwinia grandiflora*.

Isolation.—Soluble in dilute alkali; separated in the phenolic fraction of the essential oil.

Identification.—Baeckeol yields a colorless monoacetyl derivative (crystallized from methyl alcohol) found by Hems and Todd ⁵ to be dimorphic: (I) (prisms) m. 73° which, if maintained at 75° for a short time, resolidifies and then melts as II (needles) m. 79°–80°.

Nitration with nitric acid–sulfuric acid gives a nitro derivative m. 106° (C₁₂H₁₅NO₅). Blue color with 2,6-dichloroquinonechloroimide.

Fusion with sodium ethylate at 200°–220° in an atmosphere of nitrogen for 4 hr. yields methyl phloroglucinol dimethyl ether m. 67°–68°.

Properties.—Baeckeol forms yellow crystals m. 103°–104°. This phenol is soluble in hot alcohol, moderately soluble in ethyl acetate, and sparingly so in petroleum ether.

Use.—Baeckeol is not used in our industries.

¹ *J. Proc. Roy. Soc. N. S. Wales* **56** (1922), 87.

² *Ibid.* **71** (1936), 291.

³ *J. Chem. Soc.* (1940), 425.

⁴ *Ibid.* (1940), 1208.

⁵ *Ibid.*

VI. QUINONES

Hydroquinone

$C_6H_6O_2$

Mol. Weight 110.11

p-Dihydroxybenzene. Hydroquinol



Occurrence.—According to Benezet and Brun,¹ small quantities of this phenol occur, probably as glucosides, in oil of star anise (*Illicium verum* Hooker f.).

The work of Danner² indicates that hydroquinone occurs bound in the leaves of *Saxifraga crassifolia*, and Sviridova³ likewise detected the compound in products extracted from ensilaged star anise leaves. Thus, hydroquinone may heretofore not have been found in many oils because no previous treatment had served to free this phenol from its glucoside in the plant.

Isolation.—By the preparation of water soluble salts in dilute aqueous alkali solution and regeneration through acidification.

Identification.—(1) By the preparation of derivatives:

- (a) Diacetate m. 123°–124° (from water or alcohol), according to Chattaway.⁴
- (b) Dibenzoate m. 204° (corr.) (from toluene), according to Bogert and Howells;⁵ monobenzoate m. 161°–162°, by Varvoglis.⁶
- (c) Hydroquinone bis-phenylurethane m. 224°, according to Morgan and Pettet.⁷
- (d) Hydroquinone methane sulfonate m. 167° (Helferich and Papalambrou⁸), by the action of methane sulfonyl chloride in pyridine on hydroquinone.

(2) By means of color reactions:

- (a) 7 γ of hydroquinol gives a blue color with *o*-phthalic aldehyde and sulfuric acid, according to Eegriwe,⁹ while 1 γ of hydroquinone produces an orange color with phloroglucinol in alkaline solution.

Properties.—Hydroquinone is reported by Lindpaintner¹⁰ as dimorphous—but the two forms have identical melting points (172.5°).

b. 286° (Huntress and Mulliken¹¹).

Pardee and Weinrich¹² report the calculated value for $d_{4^{\circ}C}^{60^{\circ}F}$ as 1.315.

Hydroquinone sublimes without decomposition 10° below its melting point, according to Hesse.¹³

It is readily soluble in alcohol or ether. Kempf¹⁴ reported that this phenol is very sparingly soluble in benzene (0.2 g. per liter). A saturated aqueous

solution contains 5.8 per cent of hydroquinone at 15°, and 9.4 parts at 28.5°, according to Hlasiwetz and Habermann.¹⁵

On shaking with excess dimethyl sulfate and 5 N aqueous sodium hydroxide, hydroquinone yields the dimethyl ether, white flakes m. 53°–55°, b. 210°–212°. The diethyl ether melts at 70°–71°, b. 234°–235°.

Hydroquinone reduces Fehling's solution in the cold, ammoniacal silver nitrate on warming.

Use.—Hydroquinone has been extensively investigated as an antioxidant for oils and flavors. For this purpose it seems to have considerable merit (cf. Hollander and Tracy;¹⁶ Sumerford, Huff and Coleman;¹⁷ Bose¹⁸).

- ¹ *Ann. chim. anal. chim. appl.* **23** (1941), 263. *Chem. Abstracts* **38** (1944), 2164.
- ² *Botan. Arch.* **41** (1940), 168.
- ³ *Lesokhim. Prom.*, No. 11 (1939), 45. *Khim. Referat. Zhur.*, No. 5 (1940), 114. *Chem. Abstracts* **36** (1942), 3973.
- ⁴ *J. Chem. Soc.* (1931), 2496. Cf. Spasov, *Ann. Univ. Sofia II Faculté phys. -math. Livre 2*, **35** (1938), 289. *Chem. Abstracts* **34** (1940), 2343. See also Ciusa and Sollazzo, *Ann. chim. applicata* **33** (1943), 72. *Chem. Abstracts* **38** (1944), 5794.
- ⁵ *J. Am. Chem. Soc.* **52** (1930), 846.
- ⁶ *Ber.* **71** (1938), 2490.
- ⁷ *J. Chem. Soc.* (1931), 1125.
- ⁸ *Liebigs Ann.* **551** (1942), 238.
- ⁹ *Z. anal. Chem.* **125** (1943), 241.
- ¹⁰ *Mikrochemie* **27** (1939), 31. Cf. Lehmann, *Jahresber.* (1877), 566. Also Garelli, *Gazz. chim. ital.* **26**, I (1896), 76.
- ¹¹ "Identification of Pure Organic Compounds," Order I (1941), 243.
- ¹² *Ind. Eng. Chem.* **36** (1944), 603.
- ¹³ *Liebigs Ann.* **200** (1880), 242.
- ¹⁴ *Ber.* **39** (1906), 3721.
- ¹⁵ *Liebigs Ann.* **180** (1876), 345.
- ¹⁶ *J. Dairy Sci. Research* **12** (1941), 131.
- ¹⁷ *J. Am. Pharm. Assocn.* **33** (1944), 150.
- ¹⁸ *Trans. Bose Research Inst. Calcutta* **13** (1937), 71. *Chem. Abstracts* **34** (1940), 8302.

SUGGESTED ADDITIONAL LITERATURE

László Ekkert, "Color Reactions of Phenols," *Ber. ungar. pharm. Ges.* **15** (1939), 29. *Chem. Abstracts* **33** (1939), 3294.

B. N. Afana'sev, "Colorimetric Determination of Some Phenols and Naphthols," *Khim. Prom.*, No. 7 (1944), 18. *Chem. Abstracts* **39** (1945), 677. *J. Applied Chem. U.S.S.R.* **17** (1944), 335.

Hydroquinone Monomethyl Ether

 $C_7H_8O_2$

Mol. Weight 124.13

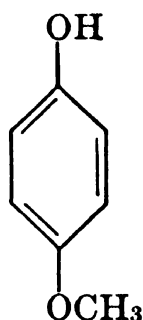
p-Methoxyphenol. *p*-Hydroxyanisole

Occurrence.—According to Benzet and Brun,¹ small quantities of this phenol ether occur, probably as glucosides, in oil of star anise (*Illicium verum* Hooker f.).

Goris and Canal² observed the corresponding methyl carbonate in the essential oil derived from the roots of *Primula auricula* L.

Isolation.—By the preparation of water-soluble salts in dilute aqueous alkali solution and regeneration through acidification.

Identification.—By the preparation of the *p*-methoxyphenyl benzoate m. 87°, according to Irvine and Smith.³

Properties.—According to Benzet and Brun,⁴ and Robinson and Smith,⁵ hydroquinone monomethyl ether has these properties:

m.	53° ⁴	b.	245° ⁴
	56° ⁵		243°–244° ⁵

It reduces Tollen's reagent.

On methylation, hydroquinone monomethyl ether forms hydroquinone dimethyl ether (1,4-dimethoxybenzene), white flakes m. 53°–55°, b. 210°–212°.

Use.—The mono- and especially the dimethyl ether are used in the perfume, cosmetic, flavor, and pharmaceutical industries.

¹ *Ann. chim. anal. chim. appl.* **23** (1941), 263. *Chem. Zentr.* II (1942), 2094. *Chem. Abstracts* **38** (1944), 2164.

² *Compt. rend.* **202** (1936), 1351.

³ *J. Chem. Soc.* (1927), 75.

⁴ *Ann. chim. anal. chim. appl.* **23** (1941), 263. *Chem. Zentr.* II (1942), 2094. *Chem. Abstracts* **38** (1944), 2164.

⁵ *J. Chem. Soc.* **129** (1926), 394.

Hydroquinone Monoethyl Ether

 $C_8H_{10}O_2$

Mol. Weight 138.16

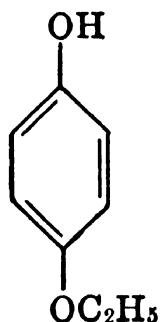
p-Ethoxyphenol. *p*-Hydroxyphenetole

Occurrence.—Small quantities of this ether occur in oil of star anise (*Illicium verum* Hooker f.) (cf. “Hydroquinone Monomethyl Ether”).

Isolation.—By the preparation of water-soluble salts in dilute aqueous alkali solution and regeneration through acidification.

Identification.—Hydroquinone monoethyl ether can be characterized through its properties.

Properties.—The following properties have been reported by Gildemeister and Hoffmann:¹

m.	66°
b.	246°–247°

Hydroquinone monoethyl ether crystallizes from water in the form of lustrous thin leaflets.

This ether is fairly easily soluble in cold water, readily soluble in hot water, very soluble in alcohol or ether.

Use.—Hydroquinone monoethyl ether has been suggested as an antioxidant of essential oils. The diethyl ether, white flakes m. 70°–71°, b. 234°–235°, is used in the perfume, cosmetic, flavor and pharmaceutical industries.

¹ “Die Ätherischen Öle,” 3d Ed., Vol. I, 606.

Thymohydroquinone

C₁₀H₁₄O₂

Mol. Weight 166.21

2-Methyl-5-isopropyl-1,4-hydroquinone. Thymoquinol

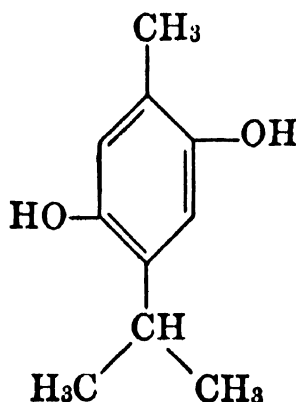

Occurrence.—Thymohydroquinone occurs in oil of *Monarda fistulosa*, *M. punctata*, and in a few other volatile oils. Recently observed by Malavya and Dutt¹ in the oil steam distilled from the seeds of *Carum roxburghianum* Benth.

Isolation.—Fractionation of the essential oil, with separation conducted on fractions boiling above 230°. Extraction with aqueous 5% sodium hydroxide solution and precipitation with carbon dioxide. Ether extraction of the residue (cf. Malavya and Dutt).

Identification.—(1) Thymohydroquinone can be characterized by oxidation to thymoquinone m. 45.5° (see "Thymoquinone").

(2) Preparation of the α -naphthylurethane m. 147°–148°, the dibenzoyl derivatives m. 141°–142°, and the phenylurethane m. 232°–233°, according to Sherk.²

Properties.—Thymohydroquinone crystallizes in the form of long white needles m. 141.5°, according to Conant and Fieser.³

The boiling point of 290° has been confirmed by several investigators.

Thymohydroquinone is sparingly soluble in cold water, soluble in hot water; soluble in alcohol or ether.

The dimethyl ether of thymohydroquinone b. 248°–250°, d_{22} 0.998, has been investigated by Reychler;⁴ it forms the main constituent of oil of arnica root and *Eupatorium capillifolium*.

Care should be exercised in the isolation and purification of this sensitive phenol not to treat its solutions with norite for the removal of colored tars since this procedure may produce quantities of thymoquinhydrone (cf. Gandini⁵).

Use.—Thymohydroquinone has been suggested as an antioxidant of essential oils.

¹ *Proc. Indian Acad. Sci.* **16A** (1942), 157. *Chem. Abstracts* **37** (1943), 1010.

² *Am. J. Pharm.* **93** (1921), 115.

³ *J. Am. Chem. Soc.* **45** (1923), 2201. Cf. Carstanjen, *J. prakt. Chem.* II, **3** (1871), 54. Ciamician and Silber, *Atti accad. Lincei* [5], **10**, I (1901), 96. Sumerford and Hartung, *J. Am. Pharm. Assocn.* **29** (1940), 65.

⁴ *Bull. soc. chim.* III, **7** (1892), 35.

⁵ *Gazz. chim. ital.* **63** (1933), 9.

SUGGESTED ADDITIONAL LITERATURE

Tito Pavolini, "Thymohydroquinone and 6-Aminothymol as Photographic Developers," *Chim. ind. agr. biol.* **12** (1936), 132. *Chem. Abstracts* **30** (1936), 6662.

L. M. Movilia, "Derivatives of Hydroquinone and *p*-Aminophenol," *Il progresso foto.* **44** (1939), 276, 279, 288. *Chem. Abstracts* **33** (1939), 8588.

Thymoquinone

$C_{10}H_{12}O_2$

Mol. Weight 164.20

2-Methyl-5-isopropyl-1,4-benzoquinone

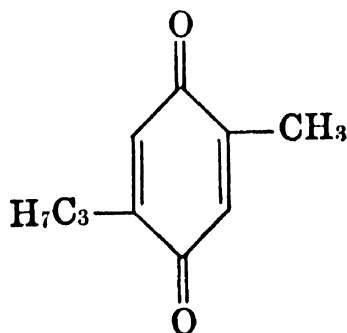

Occurrence.—Thymoquinone seems to be the only true quinone found in essential oils. It has been found in oil of *Monarda fistulosa* and *Mosla grosserrata*, accompanied by thymohydroquinone $C_{10}H_{14}O_2$. The addition product of these compounds, viz., thymoquinhydrone $C_{10}H_{12}O_2 + C_{10}H_{14}O_2$, is probably also present in these oils.

Isolation.—By fractional distillation in vacuo, and by crystallization.

Identification.—Thymoquinone can be characterized by the preparation of various derivatives:

(1) 3,6-Dibromo compound m. 73° (from alcohol), according to Chechik.¹

(2) The monoxime is formed by warming the thymoquinone with hydroxylamine hydrochloride and a little hydrochloric acid, in alcohol. According to Goldschmidt and Schmid,² the oxime melts at 160° . The dioxime melts at 235° and results from excess of the reagent on the monoxime. Using the improved technique of Sumerford and Dalton,³ the quinone may be regenerated in a state of high purity.

(3) Mono-2,4-dinitrophenylhydrazone m. 179° – 180° , according to Borsche.⁴

(4) A color test sensitive to 0.01 mg. per cc. has been developed by Craven⁵ using a 1:1 solution of alcohol and ammonia ($d = 0.88$). A bluish-violet color develops, changing finally to reddish-brown. Another colorimetric test of the same order of sensitivity is recommended by Schönberg and Ismail⁶ who found characteristic orange-red tints developing with thymoquinone and triphenylphosphine.

Properties.—Thymoquinone crystallizes in yellow triclinic plates m. 45.5° ,^{7,8} b. 232° ,⁹ and possesses an odor reminiscent of thymol and quinone. The

compound is volatile with steam. On exposure to light for five days, thymoquinone is gradually converted to dithymoquinone, which crystallizes from alcohol in yellow needles m. 199.5° – 200° , according to Smith and Tess.¹⁰

Use.—Thymoquinone has found use as an antioxidant for certain organic substances.

¹ *J. Am. Pharm. Assocn.* **22** (1933), 506.

² *Ber.* **17** (1884), 2061.

³ *J. Am. Chem. Soc.* **66** (1944), 1331.

⁴ *Liebigs Ann.* **357** (1907), 181.

⁵ *J. Chem. Soc.* (1931), 1605.

⁶ *Ibid.* (1940), 1374.

⁷ Carstanjen, *J. prakt. Chem.* [2], **3** (1871), 53.

⁸ Henderson and Boyd, *J. Chem. Soc.* **97** (1910), 1662.

⁹ Liebermann and Ilinski, *Ber.* **18** (1885), 3196.

¹⁰ *J. Am. Chem. Soc.* **66** (1944), 1323. Cf. Liebermann et al., *Ber.* **10** (1877), 2177; **18** (1885) 3193.

VII. ACIDS

Introduction.—The distillation waters of many essential oils contain small quantities of fatty acids, especially lower fatty acids such as formic, acetic, propionic, butyric, and valeric acid. Most probably they do not occur as such in the oils but are formed by hydrolysis of esters in the course of distillation. Often the free acids are accompanied by methyl and ethyl alcohol. Because of their solubility in water, these substances dissolve in the distillation water and accumulate in the cohobation oils which are obtained by re-distilling (cohobating) the distillation waters.

Some essential oils, however, contain large quantities of fatty acids. Thus, oil of orris root contains about 85 per cent myristic acid; oil of ambrette seed consists principally of palmitic acid.

Many fatty acids can be isolated and identified by adding silver nitrate to their neutralized aqueous solution, and by analyzing the silver salt after recrystallization from water. It is not the purpose of this work to enumerate the many reactions and derivatives by which the organic acids occurring in volatile oils can be identified as these are readily found in standard books on organic-analytic chemistry, especially in the excellent work by Huntress and Mulliken, "Identification of Pure Organic Compounds," John Wiley and Sons, Inc., New York, 1941, Order I, and in Heilbron's "Dictionary of Organic Compounds," Revised, Eyre & Spottiswoode, London, 1943.

Only a minimum of data will be presented in these pages to facilitate diagnostic operations with more emphasis on the less readily identifiable products. Since isolation is readily effected in most cases by alkaline extraction with subsequent acid treatment of the isolate, no remarks are inserted in this section unless unusual difficulties may be expected in this step. Low melting derivatives have in the main been avoided so as to eliminate purification troubles from oily impurities.

SUGGESTED ADDITIONAL LITERATURE

J. G. Kirchner, Arthur N. Prater, and A. J. Haagen-Smit, "Separation of Acids by Chromatographic Adsorption of Their *p*-Phenylphenacyl Esters," *Ind. Eng. Chem., Anal. Ed.*, **18** (1946), 31.

A. ALIPHATIC ACIDS

(a) SATURATED ALIPHATIC ACIDS.

Formic Acid



Mol. Weight 46.03



Occurrence.—Formic acid has been identified in many volatile oils and their distillation waters. A few oils—geranium, for instance—contain formic acid in ester form (formates).

Identification.—(1) By reduction: Warm a few cc. of the dilute (1–3%) aqueous solution with excess powdered mercuric oxide and shake. Remove the undissolved oxide by filtration and boil the clear filtrate for 30 sec. Dark grey, finely divided mercury will suddenly precipitate.

(2) The silver salt decomposes on boiling with water (difference from acetic acid).

(3) By the preparation of derivatives:

(a) *p*-Chlorophenacyl formate m. 128°, according to Moses and Reid.¹

(b) *p*-Phenylphenacyl formate m. 74°, according to Drake and Bronitsky.²

(c) Phenylmercuric formate HCOOHgPh, prepared from diphenyl mercury and formic acid, m. 135°–138° (decomp.), according to Koton.³

(d) When formic acid is admixed with several of the lower fatty acids, the azeotropic distillation technique of Schicktanz, Steele and Blaisdell⁴ may be advantageous as a means of analyzing and identifying the mixture. This will reduce the necessity of numerous fractional crystallizations of derivatives. These workers use benzene and toluene in their azeotropes.

(e) *p*-Bromobenzylpseudothiuronium bromide (prepared from *p*-bromobenzyl bromide and thiourea) yields a characteristic formate m. 148°, when permitted to react with sodium formate in alcohol, according to Dewey and Shasky.⁵

Properties.—A mobile colorless liquid of stinging, irritating and penetrating odor. Timmermans and Hennaut-Roland,⁶ Schoorl,⁷ and Grunfeld⁸ recorded these figures:

m.	8.4° ⁶	d ₄ ²⁰	1.22026 ⁶
b.	101° ⁸	d ₁₅	1.22647 ⁶
		n _D ²⁰	1.3719 ⁷

Volatile with steam. Miscible with water and forming a mixture of constant boiling point 108.1° at 774 mm.; this mixture contains 76.8 per cent formic acid and 23.2 per cent water, according to Takagi.⁹

All neutral salts of formic acid are soluble in water.

When heated with concentrated sulfuric acid, formic acid or its salts yield carbon monoxide which burns with a blue flame (difference from acetic acid).

Formic acid reduces cold potassium permanganate solutions.

Use.—Except for chemical reactions and the preparation of esters, formic acid is seldom used in the perfume and flavor industries.

¹ *J. Am. Chem. Soc.* **54** (1932), 2101.

² *Ibid.* **52** (1930), 3719.

³ *J. Gen. Chem. U.S.S.R.* **9** (1939), 912. *Chem. Abstracts* **34** (1940), 392.

⁴ *Ind. Eng. Chem., Anal. Ed.* **12** (1940), 320.

⁵ *J. Am. Chem. Soc.* **63** (1941), 3526.

⁶ *J. chim. phys.* **27** (1930), 420.

⁷ *Rec. trav. chim.* **41** (1922), 296.

⁸ *Ann. chim. phys.* [10], **20** (1933), 326.

⁹ *Bull. Chem. Soc. Japan* **14**, No. 11 (1939), 508. *Chem. Abstracts* **34** (1940), 1892.

Acetic Acid

$C_2H_4O_2$

Mol. Weight 60.05

$CH_3 \cdot COOH$

Occurrence.—Acetic acid occurs in a great many volatile oils, usually in ester form, most of them being distinguished by a pleasant, fruity odor. Linalyl, geranyl, and bornyl acetate are the main constituents of several essential oils—for example, bergamot, lavender, Siberian pine needle, etc. Numerous oils contain traces of free acetic acid.

Identification.—(1) Analysis of silver salt: Ag = 64.67%.

(2) By the preparation of derivatives:

(a) *p*-Nitrobenzyl acetate m. 78°, according to Reid.¹

(b) *p*-Iodophenyl urea, from *p*-iodobenzazide and acetamide, m. 238°–239° (corr.), according to Sah and Wang.²

(c) *p*-Bromophenacyl acetate m. 86°, according to Moses and Reid.³

(d) Dewey and Shasky⁴ prepared the *p*-bromobenzylpseudothiuronium acetate m. 149°.

(e) Mercury phenyl acetate m. 147° from diphenyl mercury and acetic acid, according to Koton.⁵

(f) *p*-Toluidide m. 153°, according to Robertson.⁶

Properties.—Acetic acid possesses a sharp and penetrating odor. Timmermans and Hennaut-Roland,⁷ Tromp,⁸ and Grunfeld⁹ reported these properties:

m.	16.7° ⁹	d_4^{25}	1.04351 ⁷
b.	117°–118° ⁹	d_4^{20}	1.04926 ⁷
		n_D^{20}	1.3721 ⁸

Acetic acid is miscible in water; volatile with steam. The neutral salts are soluble in water.

Regarding the detection of acetic acid in presence of propionic acid or *n*-butyric acid, see Osburn and Werkman,¹⁰ Osburn, Wood and Werkman,¹¹ Eijssen et al.,¹² and Schicktanz, Steele and Blaisdell.¹³

Use.—Acetic acid is used widely, especially for the preparation of many esters which have attained great importance in the flavor, perfume, cosmetic, and soap industries.

- ¹ *J. Am. Chem. Soc.* **39** (1917), 136.
- ² *Rec. trav. chim.* **59** (1940), 364.
- ³ *J. Am. Chem. Soc.* **54** (1932), 2101.
- ⁴ *Ibid.* **63** (1941), 3526.
- ⁵ *J. Gen. Chem. U.S.S.R.* **9** (1939), 912. *Chem. Abstracts* **34** (1940), 392.
- ⁶ *J. Chem. Soc.* **93** (1908), 1033.
- ⁷ *J. chim. phys.* **27** (1930), 422.
- ⁸ *Rec. trav. chim.* **41** (1922), 296.
- ⁹ *Ann. chim. phys.* [10], **20** (1933), 327.
- ¹⁰ *Ind. Eng. Chem., Anal. Ed.* **3** (1931), 264.
- ¹¹ *Ibid.* **8** (1936), 270.
- ¹² *Chem. Weekblad* **37** (1940), 535.
- ¹³ *Ind. Eng. Chem., Anal. Ed.* **12** (1940), 320.

SUGGESTED ADDITIONAL LITERATURE

Marinette Gerbault, "Calcium Salts of Acetic Acid," *Compt. rend.* **223** (1946), 674. *Chem. Abstracts* **41** (1947), 1604.

Propionic Acid



Mol. Weight 74.08

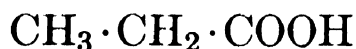

Occurrence.—Propionic acid occurs in oil of lavender, cajuput, and a few other volatile oils.

Identification.—(1) Analysis of silver salt: Ag = 59.67%.

(2) By the preparation of derivatives:

(a) Mercury phenyl propionate m. 80°–81° from diphenyl mercury and propionic acid, according to Koton.¹

(b) *p*-Chlorophenacyl propionate m. 98.2°, according to Moses and Reid.²

(c) *p*-Bromobenzylpseudothiuronium propionate m. 146°, according to Dewey and Shasky.³

(d) *p*-Phenylphenacyl propionate m. 103°, according to Hancock and Lochte.⁴

(e) *p*-Toluidide m. 126°, according to Bischoff.⁵

Properties.—Propionic acid possesses an odor similar to that of acetic acid. The following properties have been reported by Hunten and Maass,⁶ Timmermans and Hennaut-Roland,⁷ and Tromp:⁸

m.	−22.4° ⁶	$d_{\text{vac.}}^{23.1}$	0.99211 ⁶
b.	141.35° ⁷	d_4^{15}	0.99874 ⁷
		n_D^{20}	1.3862 ⁸

Propionic acid is volatile with steam. The salts are soluble in water. The acid is likewise miscible with water but can be salted out with calcium chloride and thereby differs from acetic acid.

Regarding the detection and determination of propionic acid in the presence of other fatty acids (formic to butyric), see McNair,⁹ and Schicktanz, Steele and Blaisdell.¹⁰

Use.—Propionic acid is used especially for the preparation of esters of flavor and perfume value.

¹ *J. Gen. Chem. U.S.S.R.* **9** (1939), 912. *Chem. Abstracts* **34** (1940), 392.

² *J. Am. Chem. Soc.* **54** (1932), 2101.

³ *Ibid.* **63** (1941), 3526.

⁴ *Ibid.* **61** (1939), 2450. Cf. Drake and Bronitsky, *ibid.* **52** (1930), 3719.

⁵ *Liebigs Ann.* **279** (1894), 172.

⁶ *J. Am. Chem. Soc.* **51** (1929), 154.

⁷ *J. chim. phys.* **27** (1930), 425.

⁸ *Rec. trav. chim.* **41** (1922), 297.

⁹ *J. Am. Chem. Soc.* **54** (1932), 3249.

¹⁰ *Ind. Eng. Chem., Anal. Ed.* **12** (1940), 320.

n-Butyric Acid

C₄H₈O₂

Mol. Weight 88.10

Butanoic acid

CH₃·CH₂·CH₂·COOH

Occurrence.—*n*-Butyric acid has been observed in numerous volatile oils—for example, in oil of lavender, American pennyroyal (*Hedeoma pulegioides*), valerian, nutmeg, hops, Ceylon citronella, *Eucalyptus globulus*, cajuput, niaouli, etc.

Identification.—(1) Analysis of silver salt: Ag = 55.38%.

(2) By the preparation of derivatives:

(a) Phenylmercury butyrate m. 91°, according to Koton.¹

(b) *p*-Bromobenzylpseudothiuronium butyrate m. 142°, according to Dewey and Shasky.²

(c) *p*-Bromophenacyl *n*-butyrate m. 63°, according to Moses and Reid.³

(d) *p*-Phenylphenacyl *n*-butyrate m. 97°, according to Drake and Bronitsky,⁴ and Kögl and Sparenburg.⁵

(e) *p*-Toluidide m. 75°, according to Robertson.⁶

(f) 4-Diphenyl butyrate m. 59°–60.3°, according to Hazlet and Hensley,⁷ from the butyryl chloride and 4-phenyl phenol in pyridine solution.

Properties.—*n*-Butyric acid possesses an unpleasant odor reminiscent of rancid butter. The following properties have been reported by Timmermans,⁸ and Hunten and Maass:⁹

m.	−5.55° ⁸	d _{vac.} ^{26.5}	0.9527 ⁹
b.	163.55° ⁸	d _{vac.} ^{18.4}	0.9615 ⁹
		n _D ²⁰	1.3983 ⁸

n-Butyric acid is volatile with steam. It is miscible with water and thereby differs from isobutyric acid. It is soluble in alcohol or ether.

Regarding azeotropic techniques for analysis of mixtures with other low molecular weight fatty acids (formic to valeric), see articles by Schicktanz, Steele and Blaisdell,¹⁰ and by Axe and Bratton.¹¹ The combined distillation and crystallization methods of Schutze et al.,¹² on such mixtures from petroleum acids is also applicable to other natural isolates.

“Partition chromatography” using silica gel for purposes of differential adsorption has been employed by Ramsey and Patterson¹³ to separate C₁ → C₄ fatty acids in mixtures wherein only small amounts of these products occur.

Use.—*n*-Butyric acid serves mainly for the preparation of esters which have attained considerable importance in the flavor industry.

¹ *J. Gen. Chem. U.S.S.R.* **9** (1939), 912. *Chem. Abstracts* **34** (1940), 392.

² *J. Am. Chem. Soc.* **63** (1941), 3526.

³ *Ibid.* **54** (1932), 2101.

⁴ *Ibid.* **52** (1930), 3719.

⁵ *Rec. trav. chim.* **59** (1940), 1196.

⁶ *J. Chem. Soc.* **115** (1919), 1220.

⁷ *J. Am. Chem. Soc.* **65** (1943), 2041.

⁸ *Bull. soc. chim. Belg.* **36** (1927), 506.

⁹ *J. Am. Chem. Soc.* **51** (1929), 159.

¹⁰ *Ind. Eng. Chem., Anal. Ed.* **12** (1940), 320.

¹¹ *J. Am. Chem. Soc.* **59** (1937), 1424.

¹² *Ind. Eng. Chem., Anal. Ed.* **12** (1940), 262.

¹³ *J. Official Agr. Chem.* **28** (1945), 644.

Isobutyric Acid

C₄H₈O₂

Mol. Weight 88.10

α-Methylpropanoic acid

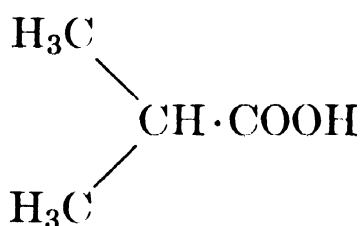

Occurrence.—Isobutyric acid has been observed in oil of laurel leaves, Roman chamomile, arnica root, masterwort; probably it occurs also in a few other volatile oils.

Identification.—(1) Analysis of silver salt: Ag = 55.38%.

(2) By the preparation of derivatives:

(a) Isopropylbenzimidazole m. 234°, according to Hancock and Lochte,¹ prepared by heating a mixture of the acid and *o*-phenylene diamine.

(b) *p*-Iodophenacyl isobutyrate m. 109.2°, according to Judefind and Reid.²

(c) *p*-Phenylphenacyl isobutyrate m. 89°, according to Clutterbuck et al.³

(d) *p*-Toluidide m. 108°–109.5°, according to von Auwers and Ungemach;⁴ m. 106°–106.5°, according to Fieser, Hartwell and Seligman.⁵

Properties.—Isobutyric acid possesses a disagreeable odor reminiscent of rancid butter. The following properties have been reported by Timmermans and Delcourt,⁶ and by Friedlander:⁷

m.	−46.1° ⁶	$n_D^{24.29}$	1.39187 ⁷
b.	154.70° ⁶	$n_D^{20.46}$	1.39343 ⁷
d_4^{30}	0.93782 ⁶	n_D^{15}	1.39525 ⁶
d_4^{15}	0.95296 ⁶		

Isobutyric acid is volatile with steam. Soluble in 5 parts of water (difference from *n*-butyric acid!) and soluble in alcohol or ether.

An aqueous solution of calcium isobutyrate does not become turbid on boiling and thereby differs from *n*-butyric acid. Hutzler and Meyer⁸ found that, on oxidation with alkaline potassium permanganate, isobutyric acid yields α -hydroxy-isobutyric acid, whereas *n*-butyric acid is destroyed by the same treatment.

More recently Kline⁹ modified this procedure by oxidizing isobutyric acid in an acetone solution with potassium permanganate. The oxidized product is precipitated with an alkaline solution of mercuric cyanide and silver nitrate. Acetic, propionic, and lactic acids fail to interfere. If the permanganate solution is opalescent, *n*-butyric acid is present; otherwise, the precipitated liquid acid may be distilled from potassium permanganate and the acetone titrated iodometrically. When the normal acid is present in an appreciable percentage with other acids, the total can be determined iodometrically after oxidation with hydrogen peroxide, and the isobutyric acid after oxidation with potassium permanganate. The normal acid may be calculated by difference.

An azeotropic method has been offered by Schicktanz, Steele and Blaisdell¹⁰ wherein both benzene and toluene act as modifiers. This method permits the analysis of mixtures containing formic, acetic, propionic, *n*-butyric acids, and isobutyric acid.

A critical study of the Dyer distillation method of evaluating fatty acids has been conducted by Clark and Hillig.¹¹ Their data indicate that this procedure is useful as a means of identifying the fatty acids (formic to valeric) but careful account must be taken of the kind and type of apparatus used which may well influence the distillation constants thereby obtained.

Hancock and Lochte¹² applied the methods of fractional alkaline extraction, esterification and distillation to complex mixtures of acids from petroleum. Where sufficiently large quantities of acidic mixtures are available for study, this technique will prove useful.

Use.—Isobutyric acid is used mainly for the preparation of esters which have attained considerable importance in the flavor industry.

¹ *J. Am. Chem. Soc.* **61** (1939), 2450.

² *Ibid.* **42** (1920), 1055.

³ *Biochem. J.* **29** (1935), 880.

⁴ *Ber.* **67** (1934), 252.

⁵ *J. Am. Chem. Soc.* **58** (1936), 1226.

⁶ *J. chim. phys.* **31** (1934), 109.

⁷ *Z. physik. Chem.* **38** (1901), 424.

⁸ *Ber.* **30** (1897), 2525.

⁹ *Biochem. Z.* **296** (1938), 202.

¹⁰ *Ind. Eng. Chem., Anal. Ed.* **12** (1940), 320.

¹¹ *J. Official Agr. Chem.* **21** (1938), 684.

¹² *J. Am. Chem. Soc.* **61** (1939), 2448.

Isovaleric Acid

C₅H₁₀O₂

Mol. Weight 102.13

β -Methyl-*n*-butyric acid. β -Methylbutanoic acid. Isopropyl acetic acid

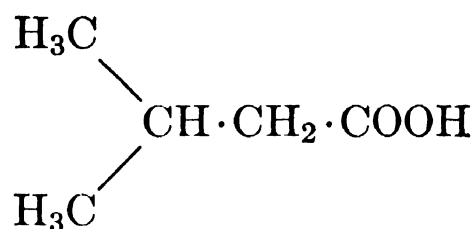

Occurrence.—Isovaleric acid occurs in numerous volatile oils—for instance, in oil of valerian, citronella, cypress, laurel leaves, American peppermint, spearmint, niaouli, hop, etc. Tsujimoto and Koyanagi¹ reported the cetyl ester in the volatile portions of pilot-whale head oil.

Identification.—(1) Analysis of silver salt: Ag = 51.67%.

(2) By the preparation of derivatives:

(a) 2-Isobutyl benzimidazole m. 190.5°, according to Hancock and Lochte.²

(b) *p*-Iodophenacyl isovalerate m. 78.8°, according to Judefind and Reid.³

(c) Anhydrous ammonium salt m. 91°, according to Raiziss and Clemence.⁴

(d) *p*-Toluidide m. 106°–107°, according to Underwood and Gale.⁵

(e) *p*-Bromobenzylpseudothiuronium isovalerate m. 148°, according to Dewey and Shasky.⁶

Properties.—Isovaleric acid has a most offensive odor, reminiscent of perspiration. The following properties have been reported by Timmermans and Hennaut-Roland,⁷ Lecat,⁸ and Tromp:⁹

m.	−30° ⁷	n _D ²⁰	1.4043 ⁹
b.	176.5° ^{7,8}	n _D ¹⁵	1.4064 ⁹
d ₄ ³⁰	0.91708 ⁷		
d ₄ ¹⁵	0.93080 ⁷		

Isovaleric acid is soluble in 23.6 parts of water at 20° and can be salted out with calcium chloride. The acid is soluble in alcohol or ether. The silver salt is very sparingly soluble in water, and particularly sensitive to light, according to Schaum and Scheid.¹⁰ Regarding the separation of isovaleric acid from other lower fatty acids by azeotropic means, see Axe and Bratton,¹¹ and Jaulmes and Mazars.¹² The fractional extraction, esterification, and dis-

tillation techniques of Hancock and Lochte¹³ are useful where sufficiently large quantities are available.

Use.—Isovaleric acid is used mainly for the preparation of esters which have attained considerable importance in the flavor industry.

¹ *J. Soc. Chem. Ind. Japan* **40**, Suppl. bind. (1937), 272. *Chem. Abstracts* **31** (1937), 7685.

² *J. Am. Chem. Soc.* **61** (1939), 2450.

³ *Ibid.* **42** (1920), 1055.

⁴ *Ibid.* **63** (1941), 3124.

⁵ *Ibid.* **56** (1934), 2119.

⁶ *Ibid.* **63** (1941), 3526.

⁷ *J. chim. phys.* **29** (1932), 554.

⁸ *Ann. Soc. Sci. Bruxelles Ser. B* **48**, I (1928), 54, 116, 118.

⁹ *Rec. trav. chim.* **41** (1922), 282, 297.

¹⁰ *Z. Wiss. Phot.* **36** (1937), 121. *Chem. Abstracts* **32** (1938), 2801.

¹¹ *J. Am. Chem. Soc.* **59** (1937), 1424.

¹² *J. chim. phys.* **34** (1937), 37.

¹³ *J. Am. Chem. Soc.* **61** (1939), 2448.

α-Methyl-*n*-Butyric Acid

C₅H₁₀O₂

Mol. Weight 102.13

α-Methylbutanoic acid. Methyl ethyl acetic acid

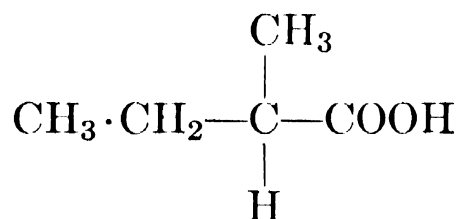

Occurrence.—This racemic acid has been found in the volatile coffee oil, in angelica root oil, and in a few other essential oils. The active forms have been reported free and as methyl and ethyl esters in champaca flower oil.

Identification.—By the preparation of derivatives, according to Taverne,¹ Scheuble and Loebel,² Schütz and Marckwald,³ Kenyon, Phillips and Pittman,⁴ Kögl and Erxleben,⁵ Drake and Veitch,⁶ Murahashi,⁷ and Hopff and collaborators:⁸

Derivative	Isomer							
	<i>d</i>		<i>l</i>		<i>dl</i>			
Amide	m.	111° ¹	[α] _D ¹⁷	+18° 19' ¹	...	m.	121° ⁸ (112°) ²	
Brucine salt-H ₂ O	m.	95° ³			m.	100° ³	...	
Aceto amide	m.	156° ⁴	[α] ₅₈₉₃ ¹⁸	+3° 23' ⁴	
<i>p</i> -Phenylphenacyl *	m.	71° ⁵	[α] _D ²⁰	+9° 54' ⁵	...	m.	70° ⁵	
	m.	70° ⁵	[α] _D	+10° 12' ⁵ (in 80% alcohol) ⁵ syn.	m.	70° ⁵	m.	70.6° ⁶
<i>p</i> -Bromophenacyl *	m.	55° ⁷			m.	55° ⁷	m.	55° ⁷

* Authors reported that the active form and the racemic form not only melt at the same temperature but give no melting point depression on mixing.

Properties.—Schimmel & Co.,⁹ Schütz and Marckwald,¹⁰ Taverne,¹¹ Hopff and collaborators,¹² Eisenlohr and Meier,¹³ Neuberg,¹⁴ Kenyon, Phillips and Pittman,¹⁵ Levene and Meyer,¹⁶ Kögl and Erxleben,¹⁷ Gilman and Kirby,¹⁸ and Murahashi¹⁹ recorded the following properties:

		<i>Properties</i>				
		<i>d</i>		<i>l</i>		<i>dl</i>
b.	176° ¹⁷ (177°) ¹¹			176°–177° ⁹		173°–174° ¹⁸ 174° ¹³
d	d ₄ ²⁰ 0.934 ¹⁵			d ₄ ²⁰ 0.934 ¹⁰	d ₂₀ 0.9332 ¹²	
[α] _D	+17° 18' ^{11,14}			–17° 51' ¹⁰	...	
	[α] ₅₄₆₁ ²⁶ +21° 34' (c = 2.503 in H ₂ O) ¹⁵			[α] ₅₄₆₁ ²⁵ –6° 0' (c = 2.002 in H ₂ O) ¹⁵	...	
	[α] _D +16° 36' ¹⁷			[α] _D ¹⁴ –10° 6' (c = 4.25, abs. alc.) ¹⁹	...	
				[M] _D ²⁵ –18° ¹⁶	...	
n	n _D ^{21,2} 1.4044 ¹⁵			

Marckwald²⁰ reported that the solubility of the silver salt for the various forms ranges from 0.73 g. in 100 cc. of water to 0.94 g. in 100 cc. Houston²¹ found that the calcium salt changed from *penta* to *hemihydrate* at 36.5° where solubility is at a maximum of 29.9 g. in 100 g. of water. At 0° the solubility is 23.05 g. and at 100°, 19.8 g. per 100 g. water.

Kenyon and Young²² noted the ready racemization of the esters of this acid with alcoholic alkali.

Use.—α-Methyl-*n*-butyric acid is used very little in our industries.

¹ *Rec. trav. chim.* **19** (1900), 108.

² *Monatsh.* **25** (1904), 1097.

³ *Ber.* **29** (1896), 57.

⁴ *J. Chem. Soc.* (1935), 1080.

⁵ *Z. physiol. Chem.* **227** (1934), 70.

⁶ *J. Am. Chem. Soc.* **57** (1935), 2623.

⁷ *Sci. Papers Inst. Phys. Chem. Research (Tokyo)* **34** (1938), 169.

⁸ *Ber.* **69B** (1936), 2244.

⁹ *Ber. Schimmel & Co.*, Oct. (1907), 19.

¹⁰ *Ber.* **29** (1896), 56.

¹¹ *Rec. trav. chim.* **13** (1894), 198, 201.

¹² *Ber.* **69B** (1936), 2244.

¹³ *Ber.* **71B** (1938), 997.

¹⁴ *Bio. Z.* **37** (1911), 504.

¹⁵ *J. Chem. Soc.* (1935), 1080.

¹⁶ *J. Am. Chem. Soc.* **56** (1934), 244.

¹⁷ *Z. physiol. Chem.* **227** (1934), 71.

¹⁸ "Organic Syntheses," Coll. Vol. I, 2d Ed., New York, John Wiley, p. 361.

¹⁹ *Sci. Papers Inst. Phys. Chem. Research (Tokyo)* **34** (1938), 169.

²⁰ *Ber.* **32** (1899), 1091.

²¹ *J. Research Natl. Bur. Stds.* **17** (1936), 55.

²² *J. Chem. Soc.* (1940), 216.

***n*-Caproic acid**C₆H₁₂O₂

Mol. Weight 116.16

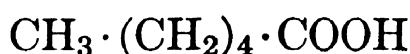
Hexanoic acid. *n*-Hexylic acid

Occurrence.—*n*-Caproic acid has been observed in oil of lemongrass, palmarosa, camphor, lavender, and in several other volatile oils.

Identification.—By the preparation of derivatives:

(1) *p*-Bromophenacyl *n*-caproate m. 72°, according to Moses and Reid,¹ 70.5° by Karrer and Geiger.²

(2) Anilide m. 94°–95°, according to Underwood and Gale.³

(3) *p*-Toluidide m. 74°–75°, according to the same authors,⁴ and Quebedeaux et al.⁵

(4) *p*-Bromobenzylpseudothiuronium caproate m. 146°, according to Dewey and Shasky.⁶

(5) *p*-Phenylphenacyl caproate m. 69°–70°, by Kögl and others.⁷

Properties.—Hexanoic acid is an oil possessing a fetid odor. Volatile with steam. Very sparingly soluble in water. The following properties have been reported by Pool and Ralston,⁸ Simon,⁹ and Quebedeaux et al.:¹⁰

f.p.	−3.24° ⁸	d ₄ ³⁰	0.91832 ⁹
b.	205.8° ⁸	d ₄ ¹⁵	0.93136 ⁹
b ₆₄	136° ⁸	d ₄ ⁰	0.94423 ⁹
b ₈	94.6° ⁸	n _D ²⁵	1.41489 ⁹
		n _D ²⁰	1.4152 ¹⁰
		n _D ¹⁵	1.41877 ⁹

For the effective separation of *n*-heptylic acid from caproic acid, Schutze and Quebedeaux and Lochte¹¹ used a liquid-liquid extraction technique with a rotatory column and petroleum ether-sodium hydroxide adjuncts.

Quebedeaux and co-workers¹² also employed fractional esterification and distillation successfully to separate *n*-caproic acid from complex mixtures of petroleum acids, including several of the methyl pentanoic and hexanoic acids.

The properties of certain metallic salts may be useful in connection with identification; for example, Kenner and Morton¹³ found that the lead salt m. 95° decomposed at 280° and yielded 54.1 per cent of diamyl ketone. Chang¹⁴ observed that the zinc salt from a complex with quinoline melted at 145°, whereas Koton¹⁵ prepared phenyl mercury caproate m. 82°–83° by the action of diphenyl mercury on the free acid. Zuffanti¹⁶ prepared the anhydrous ammonium salt m. 108°.

Comprehensive solubility tables of the acid in water, ethyl alcohol, acetone, ethyl acetate and benzene have recently been reported by Ralston and Hoerr¹⁷ who noted a eutectic with benzene at 97.7 per cent and m. −5.4°.

Use.—Hexanoic acid is used mainly for the preparation of esters that serve as adjuncts in all kinds of flavor compositions.

- ¹ *J. Am. Chem. Soc.* **54** (1932), 2101.
- ² *Helv. Chim. Acta* **24** (1941), 296.
- ³ *J. Am. Chem. Soc.* **56** (1934), 2119. See also Schwartz and Johnson, *ibid.* **53** (1931), 1065.
- ⁴ *Ibid.*
- ⁵ *Ibid.* **65** (1943), 769.
- ⁶ *Ibid.* **63** (1941), 3526.
- ⁷ *Z. physiol. Chem.* **279** (1943), 131. See Wrede and Rothhaas, *Ber.* **67** (1934), 740.
- ⁸ *Ind. Eng. Chem.* **34** (1942), 1104. See Ralston and Hoerr, *J. Org. Chem.* **7** (1942), 547.
- ⁹ *Bull. soc. chim. Belg.* **38** (1929), 56, 58.
- ¹⁰ *J. Am. Chem. Soc.* **65** (1943), 767.
- ¹¹ *Ind. Eng. Chem., Anal. Ed.* **10** (1938), 675.
- ¹² *J. Am. Chem. Soc.* **65** (1943), 769.
- ¹³ *Ber.* **72B** (1939), 452.
- ¹⁴ *Z. anorg. allgem. Chem.* **241** (1939), 207.
- ¹⁵ *J. Gen. Chem. (U.S.S.R.)* **9** (1939), 912. *Chem. Abstracts* **34** (1940), 392.
- ¹⁶ *J. Am. Chem. Soc.* **63** (1941), 3123.
- ¹⁷ *J. Org. Chem.* **7** (1942), 554.

Enanthic Acid

$C_7H_{14}O_2$

Mol. Weight 130.18

Oenanthic acid. Heptanoic acid. *n*-Heptylic acid. *n*-Heptoic acid

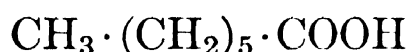

Occurrence.—Enanthic acid has been identified in oil of hop, in the oil distilled from calamus herb, in Himalaya cedarwood oil, and in a few other volatile oils.

Identification.—By the preparation of derivatives:

- (1) *p*-Bromopseudothiuronium enanthate m. 147°, according to Dewey and Shasky.¹
- (2) 2-*n*-Hexylbenzimidazole m. 136°–138°, according to Quebedeaux et al.,² and Weidenhagen.³
- (3) *p*-Bromophenacyl enanthate m. 72°, according to Moses and Reid.⁴
- (4) Toluidide m. 81°, according to Robertson.⁵
- (5) Amide m. 96°, by the same author; ⁶ 94.5°–95°, according to Quebedeaux et al.⁷

Properties.—The following properties have been reported by Pool and Ralston,⁸ and Bryusova and Ogorodnikova:⁹

f.p.	−6.26° ⁸	d_{15}	0.9214 ⁹
b.	223.0° ⁸	n_{15}	1.4289 ⁹
b_{64}	150.8° ⁸		
b_{10}	119° ⁹		

According to Franchimont,¹⁰ the barium salt of enanthic acid crystallizes from water in the form of anhydrous leaflets m. 240°. The dried zinc salt melts at 131°–132°.

The lead salt is reported by Kenner and Morton¹¹ to melt at 85° and to decompose at 285°, yielding 91.89 per cent of dihexyl ketone.

The acid yields a characteristic salt with the microchemical Cu-pyridine reagent; the salt is described by Huijsse¹² as "bluish-green plates."

Carrick, Dahl, Farstad and Glendenning¹³ employed the distillation method of Dyer to analyze mixtures consisting of small amounts of heptylic, caprylic, capric, and pelargonic acids.

Quebedeaux et al.¹⁴ likewise employing fractional distillation methods, but on large stocks of the esters, separated complex mixtures of petroleum aliphatic acids including enanthic acid.

Extensive solubility tables are reported by Ralston and Hoerr¹⁵ for the acid in water, acetone, ethyl alcohol, ethyl acetate, and benzene. With benzene a eutectic mixture at 98.8 per cent and m. -6.5° was observed.

Use.—Enanthic acid is used mainly for the preparation of esters which serve as adjuncts in various types of flavor compositions.

However, in another direction of potential use, the acid is reported by Hoffman, Schweitzer and Dalby¹⁶ to possess marked fungistatic action.

¹ *J. Am. Chem. Soc.* **63** (1941), 3526.

² *Ibid.* **65** (1943), 767.

³ *Ber.* **69** (1936), 2268.

⁴ *J. Am. Chem. Soc.* **54** (1932), 2101.

⁵ *J. Chem. Soc.* **115** (1919), 1220.

⁶ *Ibid.*

⁷ *J. Am. Chem. Soc.* **65** (1943), 767.

⁸ *Ind. Eng. Chem.* **34** (1942), 1104. See Ralston and Hoerr. *J. Org. Chem.* **7** (1942), 547.

⁹ *J. Applied Chem.* (U.S.S.R.) **14** (1941), 636. *Chem. Abstracts* **36** (1942), 3486.

¹⁰ *Liebigs Ann.* **165** (1873), 244.

¹¹ *Ber.* **72B** (1939), 455.

¹² *Tijdschr. Artsenijkunde* **1** (1943), 218. *Chem. Zentr.* II (1943), 548.

¹³ *Am. Paint J.* **25** (Oct. 21, 1940), 58.

¹⁴ *J. Am. Chem. Soc.* **65** (1943), 767.

¹⁵ *J. Org. Chem.* **7** (1942), 554.

¹⁶ *Am. J. Cancer* **38** (1940), 569.

n-Caprylic Acid

C₈H₁₆O₂

Mol. Weight 144.21

Octanoic acid

CH₃·(CH₂)₆·COOH

Occurrence.—*n*-Caprylic acid occurs in oil of hop, nutmeg, camphor, sweet orange, American pennyroyal (*Hedeoma pulegioides*), oil of lime, tobacco flowers, and in a few other volatile oils.

Identification.—By the preparation of derivatives:

(1) *p*-Bromophenacyl *n*-caprylate m. 67.4°, according to Moses and Reid.¹

(2) Amide m. 105°–106°, according to Deffet,² Igolen and Palfray,³ and Quebedeaux et al.⁴

- (3) *p*-Toluidide m. 70°, according to Robertson.⁵
 (4) *p*-Phenylphenacyl ester m. 66.6°–67.3°, according to Lochte et al.⁶
 (5) *p*-Bromobenzylpseudothiuronium caprylate m. 147°, according to Dewey and Shasky.⁷

Properties.—The following properties have been reported by Pool and Ralston,⁸ Eisenlohr,⁹ Deffet,¹⁰ Quebedeaux and others,¹¹ and Sabetay, Igolen and Palfray:¹²

m.	16.3° ^{8,10}	d_4^{30}	0.90087 ¹⁰
b.	239.7° ⁸	d_4^{21}	0.90866 ⁹
b ₁₂₈	183.3° ⁸	d_4^{20}	0.90884 ¹⁰
b ₁₆	134.6° ⁸	n_D^{20}	1.4335 ¹²
b ₄	109.1° ⁸		1.4327 ¹¹

Comprehensive solubility studies with this acid have been conducted by Ralston and Hoerr,¹³ employing a variety of solvents including water, alcohol, acetone, 2-butanone, benzene, acetic acid, carbon tetrachloride, chloroform, and many others. At 20°, 0.068 g. of acid dissolves in 100 g. of water; at 100° the solubility is 0.25 g. The acid is soluble in alcohol, acetone, benzene, and several other organic solvents.

The calcium salt of *n*-caprylic acid is most sparingly soluble in cold water; the zinc salt melts at 135°; the silver salt is a curdy precipitate; ammonium salt from alcohol m. 54° (cf. Kench and Malkin¹⁴), the anhydrous salt melting at 114°, according to Zuffanti.¹⁵ The octadecyl ammonium salt and amide melt at 57.5° and 79.0°–79.5°, respectively (Hunter¹⁶), the copper salt at 264°–266°; the lead salt at 82.0°–82.8° (cf. Piper, Fleiger, Smith and Kerstein¹⁷). According to Kenner and Morton,¹⁸ lead caprylate melts at 100° and decomposes at 280°, forming 71.59 per cent of diheptyl ketone.

Schutze et al.¹⁹ successfully employed fractional precipitation of salts, fractional alkaline extraction and distillation of a complex mixture of petroleum acids in the separation of valeric, butyric, and caprylic acids in petroleum acid mixtures where an appreciable amount of stock was available. Later Quebedeaux and co-workers²⁰ used similar methods with highly effective fractionating columns to separate caprylic from a mixture of several isomeric hexanoic and heptanoic acids.

Use.—*n*-Caprylic acid is used mainly for the preparation of esters which serve as adjuncts in various flavor compositions.

¹ *J. Am. Chem. Soc.* **54** (1932), 2101.

² *Bull. soc. chim. Belg.* **40** (1931), 390.

³ *Compt. rend.* **213** (1941), 805. Cf. Robertson, *J. Chem. Soc.* **115** (1919), 1220.

⁴ *J. Am. Chem. Soc.* **65** (1943), 770.

⁵ *J. Chem. Soc.* **115** (1919), 1220.

⁶ *Ind. Eng. Chem., Anal. Ed.* **12** (1940), 262. Cf. Drake & Bronitsky, *J. Am. Chem. Soc.* **52** (1930), 3715.

⁷ *J. Am. Chem. Soc.* **63** (1941), 3526.

- ⁸ *Ind. Eng. Chem.* **34** (1942), 1105. Cf. Ralston and Hoerr, *J. Org. Chem.* **7** (1942), 546.
⁹ *Z. physik. Chem.* **75** (1911), 590.
¹⁰ *Bull. soc. chim. Belg.* **40** (1931), 390.
¹¹ *J. Am. Chem. Soc.* **65** (1943), 770.
¹² *Compt. rend.* **213** (1941), 805. *Chem. Abstracts* **37** (1943), 4856. Cf. Robertson, *J. Chem. Soc.* **115** (1919), 1220.
¹³ *J. Org. Chem.* **7** (1942), 546; **9** (1944), 329.
¹⁴ *J. Chem. Soc.* (1939), 230.
¹⁵ *J. Am. Chem. Soc.* **63** (1941), 3123.
¹⁶ *Iowa State College J. Sci.* **15** (1941), 226.
¹⁷ *Ind. Eng. Chem.* **31** (1939), 309.
¹⁸ *Ber.* **72B** (1939), 452.
¹⁹ *Ind. Eng. Chem., Anal. Ed.* **12** (1940), 262.
²⁰ *J. Am. Chem. Soc.* **65** (1943), 767.

SUGGESTED ADDITIONAL LITERATURE

Aage Lund and Olav Årstad, "Determination of the Fat Acid Content of Soaps Containing Coconut Oil," *Tids. Kjemi Bergvesen Met.* **1** (1941), 32-3, 83-6. *Chem. Abstracts* **36** (1942), 1796.

Pelargonic Acid

C₉H₁₈O₂

Mol. Weight 158.23

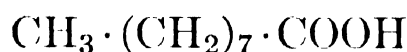
Nonanoic acid. *n*-Nonylic acid

Occurrence.—This acid has been identified in oil of hop and in a few other essential oils.

Identification.—By the preparation of derivatives:

- (1) *p*-Bromophenacyl pelargonate m. 68.5°, according to Moses and Reid.¹
- (2) Amide m. 98.9°-99.0°, according to Deffet,² and Quebedeaux et al.³
- (3) *p*-Toluidide m. 84°, according to Robertson.⁴

Properties.—Pelargonic acid is an oil, but at low temperature it crystallizes in the form of leaflets. It is slowly volatile with steam, and sparingly soluble in water. The following properties have been reported by Pool and Ralston,⁵ Quebedeaux et al.,⁶ and Deffet:⁷

f.p.	12.24° ⁵	d ₄ ²⁰	0.90552 ⁷
b.	255.6° ⁵	d ₄ ¹⁵	0.90932 ⁷
b ₁₂₈	196.9° ⁵	n _D ²⁰	1.4379 ⁶
b ₁₆	147.5° ⁵		
b ₄	121.2° ⁵		

Extensive data on the solubilities of pelargonic acid in selected useful solvents have been reported by Hoerr and Ralston.⁸ It has been found that 0.026 g. of the acid dissolves in 100 g. of water at 20°, and 0.051 g. at 60°.

Appreciable quantities are soluble in alcohol, acetone, benzene, and acetic acid with eutectics existing for the two latter solvents.

The calcium salt of pelargonic acid melts at 216° (crystallized from dilute methyl alcohol), according to Harries.⁹ The zinc salt melts at 131°–132°.

The ammonium salt has been found by Zuffanti¹⁰ to melt at 115° (from alcohol).

Piper, Fleiger, Smith and Kerstein¹¹ reported the lead salt to melt at 98°–98.5°, whereas Kenner and Morton¹² observed this compound to melt at 95°–100°, decomposing at 299° to form 82.1 per cent of dioctyl ketone.

Use.—Pelargonic acid is used for the preparation of a few esters which serve as adjuncts in certain flavor compounds.

¹ *J. Am. Chem. Soc.* **54** (1932), 2101.

² *Bull. soc. chim. Belg.* **40** (1931), 391.

³ *J. Am. Chem. Soc.* **65** (1943), 770.

⁴ *J. Chem. Soc.* **115** (1919), 1220.

⁵ *Ind. Eng. Chem.* **34** (1942), 1105. Cf. Ralston and Hoerr, *J. Org. Chem.* **7** (1942), 546.

⁶ *J. Am. Chem. Soc.* **65** (1943), 770.

⁷ *Bull. soc. chim. Belg.* **40** (1931), 388.

⁸ *J. Org. Chem.* **9** (1944), 329; **7** (1942), 546.

⁹ *Liebigs Ann.* **343** (1905), 358. Cf. Zincke and Franchimont, *ibid.* **164** (1872), 337.

¹⁰ *J. Am. Chem. Soc.* **63** (1941), 3123.

¹¹ *Ind. Eng. Chem.* **31** (1939), 307.

¹² *Ber.* **72B** (1939), 452.

n-Capric Acid

C₁₀H₂₀O₂

Mol. Weight 172.26

Decanoic acid *n*-Decylic acid.

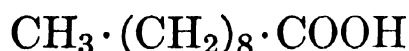

Occurrence.—*n*-Capric acid occurs in oil of chamomile, lemongrass, hop, American pennyroyal (*Hedeoma pulegioides*), lime, pha-chium, aniseed, fusel oil from grape bagasse, and a few other volatile oils.

Identification.—By the preparation of derivatives:

(1) *p*-Bromobenzylthiuronium caprate m. 145°, according to Dewey and Shasky.¹

(2) Phenyl hydrazide m. 105°, by Stempel, Jr., and Schaffel.²

(3) *p*-Bromophenacyl *n*-caprate m. 67°, according to Moses and Reid.³

(4) *n*-Capramide m. 100.1°, according to Deffet.⁴

(5) *p*-Toluidide m. 78°, according to Robertson.⁵

Properties.—The following properties have been reported by Pool and Ralston,⁶ and Schuette and Vogel:⁷

solid. pt.	31.60° ⁷	b.	270° ⁶
m.	31.60° ⁷	b ₁₂₈	209.8° ⁶
		b ₁₆	159.4° ⁶
		b ₄	132.7° ⁶

Lepkovsky, Feskov and Evans⁸ recommended separating *n*-capric acid from its near homologues by fractional distillation of the methyl esters.

Carrick, Dahl, Farstad and Glendening⁹ employed the Dyer fractional distillation method to separate mixtures of heptylic, caprylic, pelargonic, and capric acids.

Schuette and Vogel¹⁰ reported the solidification-point curves of capric-lauric mixtures as a means of analyzing these acids, also those of capric-caprylic acids.

Considerable data on the solubilities of capric acid in organic solvents have been supplied by Hoerr and Ralston.¹¹

These authors also determined the solubility of this acid in water as:

0.015 g. per 100 g. of H₂O at 20°
0.100 g. per 100 g. of H₂O at 100°

Piper, Fleiger, Smith and Kerstein¹² noted the lead salt as m. 96.5°–97.0°; Kench and Malkin¹³ found that the ammonium salt melted at 68°; Hunter¹⁴ reported that the octadecylamine salt and amide melted at 62°–62.5° and 83°–83.5°, respectively.

Use.—*n*-Capric acid is used for the preparation of a few esters which serve as adjuncts in certain flavor compositions.

¹ *J. Am. Chem. Soc.* **63** (1941), 3526.

² *Ibid.* **64** (1942), 470.

³ *Ibid.* **54** (1932), 2101.

⁴ *Bull. soc. chim. Belg.* **40** (1931), 391.

⁵ *J. Chem. Soc.* **115** (1919), 1221.

⁶ *Ind. Eng. Chem.* **34** (1942), 1104.

⁷ *Oil and Soap* **22** (1945), 239; **16** (1939), 209.

⁸ *J. Am. Chem. Soc.* **58** (1936), 978.

⁹ *Am. Paint J.* **25** (1940), 58.

¹⁰ *Oil and Soap* **16** (1939), 209; **22** (1945), 239.

¹¹ *J. Org. Chem.* **7** (1942), 546; **9** (1944), 329.

¹² *Ind. Eng. Chem.* **31** (1939), 307.

¹³ *J. Chem. Soc.* (1939), 232.

¹⁴ *Iowa State College J. Sci.* **15** (1941), 226.

n-Undecylic Acid

C₁₁H₂₂O₂

Mol. Weight 186.29

Undecanoic acid. Hendecanoic acid

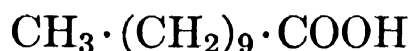

Occurrence.—This acid occurs in oil of *Artemisia frigida*, in the leaf oil of *Chamaecyparis pisifera* Engl., and in the (concrete) oil of orris root.

Identification.—By the preparation of derivatives:

(1) *n*-Undecylanilide m. 71°, according to Robertson.¹

(2) *n*-Undecyl-*p*-toluidide m. 80°, according to the same author.²

Properties.—The following properties have been reported by Ralston and Hoerr,³ Pool and Ralston,⁴ Garner and Ryder,⁵ Waterman and Bertram,⁶ and Levene and West:⁷

f.p.	28.13° ^{3,4}	d ₂₀	0.9948 ⁵
m.	28°–29° ⁷	n _D ⁷⁰	1.4203 ⁶
b.	284° ⁴		
b ₁₂₈	222.2° ⁴		
b ₁₆	170.8° ⁴		
b ₄	143.3° ⁴		

Ralston and Hoerr⁸ found the solubility of this acid in water at 20° to be 0.0093 g. per 100 g. of solvent and 0.015 g. per 100 g. of solvent at 60°. These authors also determined the solubilities of the acid in numerous organic solvents, observing a good solubility in alcohol, acetone, benzene and acetic acid at ordinary temperatures. The acid crystallizes from acetone at –10°.

The ammonium salt melts at 72°, according to Kench and Malkin;⁹ the lead salt at 90°–92°, decomposing at 298° to yield 78.2 per cent ketone, according to Kenner and Morton.¹⁰ The barium and silver salts are only slightly soluble in water.

Use.—Hendecanoic acid is used for the preparation of a few esters which are employed in the perfume and flavor industries.

¹ *J. Chem. Soc.* **115** (1919), 1220.

² *Ibid.*

³ *J. Org. Chem.* **7** (1942), 546.

⁴ *Ind. Eng. Chem.* **34** (1942), 1104.

⁵ *J. Chem. Soc.* **127** (1925), 728.

⁶ *Rec. trav. chim.* **46** (1927), 701.

⁷ *J. Biol. Chem.* **18** (1914), 464.

⁸ *J. Org. Chem.* **7** (1942), 546; **9** (1944), 329.

⁹ *J. Chem. Soc.* (1939), 230.

¹⁰ *Ber.* **72B** (1939), 452.

Lauric Acid

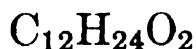

Mol. Weight 200.31

n-Dodecanoic acid. *n*-Dodecylic acid

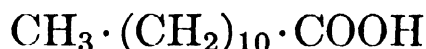

Occurrence.—Lauric acid occurs in oil of camphor, laurel berry and *Cupressus torulosa*. Moreover, Boekenoogen¹ reports that this acid is present as ester in 7 per cent of all the commercial fixed oils; thus hydrolytic cleavage might be expected to give rise to lauric acid in a number of steam distilled volatile oils.

Identification.—By the preparation of derivatives:

(1) *p*-Chlorophenacyl laurate m. 70°, according to Hann, Reid and Jamieson.²

(2) Lauramide m. 100°, according to Robertson.³

(3) *p*-Toluidide m. 87°, according to the same author.⁴

(4) *p*-Bromobenzylpseudothiuronium laurate m. 142°, by Dewey and Shasky.⁵

Properties.—Physical properties determined on carefully purified products have been reported recently by Schuette and Vogel,⁶ Pool and Ralston,⁷ and Ralston and Hoerr.⁸ Data from several of these authors are reported here:

f.p.	43.86° ^{7,8}
b.	298.9° ⁷
b ₁₂₈	234.3° ⁷
b ₁₆	181.8° ⁷
b ₄	154.1° ⁷

Lauric acid crystallizes from alcohol in the form of needles. Ralston and Hoerr⁹ determined the solubility in water as:

0.0055 g. per 100 g. of water at 20°
0.0087 g. per 100 g. of water at 60°

The same authors also carefully investigated the solubility of this acid in a wide variety of organic solvents, whereas Foreman and Brown¹⁰ determined the solubilities of lauric acid in Skellysolve B, acetone, and methyl alcohol at low temperatures.

Lauric acid is volatile with superheated steam.

Schuette and Vogel¹¹ determined the solidification-point curves in mixtures with capric and also with myristic acids. These determinants are valuable as a means of analysis.

Cassidy¹² used activated charcoal as an adsorptive agent for separation of lauric acid from stearic, palmitic and myristic acids.

Kench and Malkin¹³ observed the ammonium salt as melting at 77°, while in a sealed tube the melting point is 130°.

The heavy metal salts are most sparingly soluble in water. The silver salt melts at 212°–213°. Piper et al.¹⁴ reported that the lead salt melts at 103.8°–104.2°. Kenner and Morton¹⁵ found that this salt m. 98° decomposes at 302° to produce 80.1 per cent of ketone.

Use.—Lauric acid is used for the preparation of several esters which serve as solvents, diluents, and occasionally are encountered as adulterants of essential oils.

¹ Oliën, Vetten, *Oliezaden* **26** (1941), 143. *Chem. Abstracts* **37** (1943), 2778.

² *J. Am. Chem. Soc.* **52** (1930), 819.

³ *J. Chem. Soc.* **115** (1919), 1220.

⁴ *Ibid.*

⁵ *J. Am. Chem. Soc.* **63** (1941), 3526.

⁶ *Oil and Soap* **16** (1939), 209.

⁷ *Ind. Eng. Chem.* **34** (1942), 1104.

⁸ *J. Org. Chem.* **7** (1942), 546.

⁹ *Ibid.* **7** (1942), 546; **9** (1944), 329.

¹⁰ *Oil and Soap* **21** (1944), 183.

¹¹ *Ibid.* **16** (1939), 209.

¹² *J. Am. Chem. Soc.* **63** (1941), 2735.

¹³ *J. Chem. Soc.* (1939), 230.

¹⁴ *Ind. Eng. Chem.* **31** (1939), 307.

¹⁵ *Ber.* **72B** (1939), 455.

Myristic Acid

 $C_{14}H_{28}O_2$

Mol. Weight 228.36

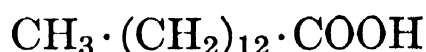
n-Tetradecanoic acid. *n*-Tetradecylic acid

Occurrence.—Myristic acid is the principal constituent of the oil distilled from orris root; it occurs in nutmeg oil, pha-chium, and in a few other essential oils. Boekenoogen¹ reports that this acid is present also in 3 per cent of all the commercial fixed oils from the plant world.

Identification.—By the preparation of derivatives:

- (1) *p*-Chlorophenacyl myristate m. 76°, according to Hann, Reid and Jamieson.²
- (2) *n*-Myristamide m. 103°, according to Robertson.³
- (3) *p*-Toluidide m. 93°, according to Robertson.⁴

Properties.—Myristic acid is an almost odorless, crystalline mass. Several authors recently reported the results of careful studies on the physical properties of this acid: Francis and Piper,⁵ Schuette and Vogel,⁶ Foreman and Brown,⁷ Ralston and Hoerr,⁸ and Pool and Ralston.⁹ The data given here are those of Pool and Ralston:

f.p.	54.01°
b.	326.2° (by extrapolation)
b ₁₂₈	257.3°
b ₁₆	202.4°
b ₄	173.9°

According to Ralston and Hoerr,¹⁰ myristic acid is soluble in water to the amount of 0.0020 g. per 100 g. of H₂O at 20° and 0.0034 g. at 60°. These same authors also investigated the solubilities of this acid in numerous organics. The acid dissolves readily in alcohol, ether, benzene, acetone, or acetic acid.

Foreman and Brown¹¹ studied the solubilities in acetone, methyl alcohol and Skellysolve B at low temperatures with the view of using such procedure for purification of the acid.

Schuette and Vogel¹² prepared solidification-point curves of the pure acid in mixture with lauric and palmitic acid and employed these as indexes of purity and identity.

Cassidy¹³ described a procedure of adsorption analysis employing carbon for the differential separation of mixtures of lauric, stearic, palmitic, and myristic acid.

Lepkovsky, Feskov and Evans¹⁴ suggested a method of separating myristic acid from other fatty acids by distillation.

According to Jacobson and Holmes,¹⁵ the silver salt of myristic acid melts at 211°, the magnesium salt at 131.6°. The same authors¹⁶ suggested using this salt for the separation of myristic acid from palmitic and stearic acid.

The lead salt, according to Piper, Fleiger, Smith and Kerstein,¹⁷ melts at 109.6°–110.2°, whereas the ammonium salt is reported by Kench and Malkin¹⁸ as m. 84°. The dodecylamine salt and amide, according to Hunter,¹⁹ melt at 72.5°–73° and 84°–85°, respectively.

Use.—Myristic acid is occasionally employed in the sophistication of concrete orris root oil in which it also occurs naturally. Myristic acid is used for the preparation of esters—methyl or ethyl myristate, for example—which serve as diluents of perfume compositions and as adulterants of essential oils.

¹ *Oliën, Vetten, Oliezaden* **26** (1941), 143. *Chem. Abstracts* **37** (1943), 2778.

² *J. Am. Chem. Soc.* **52** (1930), 819.

³ *J. Chem. Soc.* **115** (1919), 1220.

⁴ *Ibid.*

⁵ *J. Am. Chem. Soc.* **61** (1939), 577.

⁶ *Oil and Soap* **16** (1939), 209.

⁷ *Ibid.* **21** (1944), 183.

⁸ *J. Org. Chem.* **7** (1942), 546; **9** (1944), 329.

⁹ *Ind. Eng. Chem.* **34** (1942), 1104.

¹⁰ *J. Org. Chem.* **7** (1942), 546; **9** (1944), 329.

¹¹ *Oil and Soap* **21** (1944), 183.

¹² *Ibid.* **16** (1939), 211.

¹³ *J. Am. Chem. Soc.* **63** (1941), 2735.

¹⁴ *Ibid.* **58** (1936), 978.

¹⁵ *J. Biol. Chem.* **25** (1916), 31.

¹⁶ *Ibid.*, 55.

¹⁷ *Ind. Eng. Chem.* **31** (1939), 307.

¹⁸ *J. Chem. Soc.* (1939), 230.

¹⁹ *Iowa State Coll. J. Sci.* **15** (1941), 228.

Palmitic Acid

C₁₆H₃₂O₂

Mol. Weight 256.42

n-Hexadecanoic acid. Hexadecylic acid

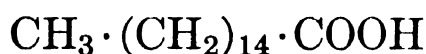

Occurrence.—Palmitic acid occurs in oil of vetiver, Canadian snakeroot, pimenta, myrrh, cascarilla, in the seed oils of ambrette, celery, anise, parsley and carrot, also in expressed almond oil; as ester in the volatile oil of *Artemisia verlotorum*, and in quite a few other essential oils. Moreover, Boekennoogen¹ points out that palmitic acid is present in 11 per cent of all commercial fixed oils, which fact may readily account for its occurrence in many ethereal fractions therefrom.

Identification.—By the preparation of derivatives:

- (1) *p*-Chlorophenacyl palmitate m. 82°, according to Hann, Reid, and Jamieson.²
- (2) Palmitamide m. 105.3°, according to Guy and Smith.³
- (3) *p*-Bromoanilide m. 113.2°, according to Houston.⁴
- (4) *p*-Chlorobenzylpseudothiuronium palmitate m. 146°, by Dewey and Sperry;⁵ the corresponding *p*-bromo compound, according to Dewey and Shasky,⁶ melts at 135°.

Properties.—Reliable stocks of palmitic acid have been employed in the reassaying of the physical properties of palmitic acid, as reported by Schuette and Vogel,⁷ Pool and Ralston,⁸ Francis and Piper,⁹ Guy and Smith,¹⁰ Ralston and Hoerr.¹¹ The findings of Ralston and co-workers^{8,11} are given here:

f.p.	62.82°
b.	351.5° (obtained by extrapolation)
b ₁₂₈	278.7°
b ₁₆	221.5°
b ₄	192.2°

Palmitic acid forms needles or greasy scales, insoluble in water. According to Ralston and Hoerr,¹² the solubility in water ranges from 0.00072 g. per 100 g. of solvent at 20° to 0.0012 g. at 60°.

The same authors studied the solubility of this acid in a variety of organic compounds. Palmitic acid may be recrystallized from alcohol, benzene, or acetone.

One hundred g. of absolute alcohol dissolve 7.21 g. of palmitic acid at 20.0° and 2600 g. at 60°, according to Ralston and Hoerr.¹³

The acid may be titrated in alcohol but not in water.

Solidification-point curves of palmitic-myristic and palmitic-stearic acid mixtures have been prepared by Schuette and Vogel.¹⁴

Manunta¹⁵ used dry magnesium sulfate or franconite as an agent for chromatographic separation of palmitic, stearic, and oleic acid mixtures in petroleum ether.

The ammonium salt melts at 89°, according to Kench and Malkin,¹⁶ and the lead salt at 113.0°–113.6°, according to Piper, Fleiger, Smith, and Kerstein.¹⁷

Salts and amides derived from octadecylamine and dodecylamine are reported by Hunter¹⁸ to melt as follows:

<i>Octadecylamine</i>		<i>Dodecylamine</i>	
<i>Salt</i>	<i>Amide</i>	<i>Salt</i>	<i>Amide</i>
85°–85.5°	91.5°–92°	72°–73°	82.5°–83°

Use.—Palmitic acid is used mainly as a base of soaps.

¹ *Oliën, Vetten, Oliezaden* **26** (1941), 143. *Chem. Abstracts* **37** (1943), 2778.

² *J. Am. Chem. Soc.* **52** (1930), 819.

- ³ *J. Chem. Soc.* (1939), 617. See Robertson, *J. Chem. Soc.* **115** (1919), 1220.
⁴ *J. Am. Chem. Soc.* **62** (1940), 1303.
⁵ *Ibid.* **61** (1939), 3251.
⁶ *Ibid.* **63** (1941), 3526.
⁷ *Oil and Soap* **16** (1939), 209; **17** (1940), 155.
⁸ *Ind. Eng. Chem.* **34** (1942), 1104.
⁹ *J. Am. Chem. Soc.* **61** (1939), 577.
¹⁰ *J. Chem. Soc.* (1939), 615.
¹¹ *J. Org. Chem.* **7** (1942), 546; **9** (1944), 329.
¹² *Ibid.* **7** (1942), 546.
¹³ *Ibid.*
¹⁴ *Oil and Soap* **16** (1939), 209; **17** (1940), 155.
¹⁵ *Helv. Chim. Acta* **22** (1939), 1156.
¹⁶ *J. Chem. Soc.* (1939), 230.
¹⁷ *Ind. Eng. Chem.* **31** (1939), 307. Also see Whitmore and Lauro, *ibid.* **22** (1930), 646.
¹⁸ *Iowa State Coll. J. Sci.* **15** (1941), 226, 228.

Stearic Acid

C₁₈H₃₆O₂

Mol. Weight 284.47

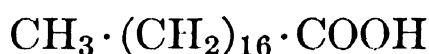
n-Octadecanoic acid. *n*-Octadecylic acid

Occurrence.—Stearic acid has been observed in Himalayan cedar oil, in oil of cascarilla, and in a few other essential oils.

Identification.—By the preparation of derivatives:

- (1) *p*-Chlorophenacyl stearate m. 86°, according to Hann, Reid and Jamieson.¹
- (2) Stearanilide m. 95.05° (capillary tube 95.5°), according to Guy and Smith,² obtained through the acid chloride and cold aniline, and crystallized from alcohol or benzene.
- (3) *p*-Bromobenzylpseudothiuronium stearate m. 135°, by Dewey and Shasky.³
- (4) *p*-Bromoanilide m. 115.2°, by Houston.⁴
- (5) Phenylmercuric stearate m. 90°–92°, prepared from diphenyl mercury and the free acid by Koton.⁵

Properties.—Recently, reliable studies on the physical properties of this acid have been reported by Francis and Piper,⁶ Guy and Smith,⁷ Schuette and Vogel,⁸ Pool and Ralston,⁹ and Ralston and Hoerr.¹⁰

The following data are selected from work by Guy and Smith,⁷ and Pool and Ralston:⁹

f.p.	69.60° ⁷	b ₁₂₈	299.7° ⁹
m.	69.62° ⁷	b ₁₆	240.0° ⁹
b.	376.1° ⁹ (value obtained by extrapolation)	b ₄	209.2° ⁹

Ordinary stearic acid consists of odorless leaflets and is polymorphic. It is, for all practical purposes, considered insoluble in water which dissolves

only 0.00029 g. of acid per 100 g. of solvent at 20°, according to Ralston and Hoerr.¹¹ Absolute alcohol dissolves 2.25 g. per 100 g. of solvent. The same authors also studied the quantitative solubilities of this acid in numerous other organic solvents. Stearic acid does not dissolve in cold sodium carbonate solutions nor in 0.1 N aqueous potassium hydroxide solutions, but it can be titrated in alcohol.

The ammonium salt of stearic acid melts at 93° (Kench and Malkin¹²), the lead salt at 115°–115.5° (Piper et al.¹³), the silver salt at 205° (Jacobson and Holmes¹⁴). The salts and amides of octadecylamine and dodecylamine are reported by Hunter¹⁵ to melt at:

<i>Octadecylamine</i>		<i>Dodecylamine</i>	
<i>Salt</i>	<i>Amide</i>	<i>Salt</i>	<i>Amide</i>
89.5°–90.5°	95.5°–96°	69°–70°	85°–85.5°

Manunta¹⁶ separated stearic, oleic, and palmitic acid mixtures by chromatographic adsorption on dry magnesium sulfate from a petroleum ether solution.

Schuette and Vogel¹⁷ determined the solidification-point curves of stearic-palmitic acid mixtures and recommended these determinants as a diagnostic tool.

Use.—Stearic acid is used most widely in the preparation of all kinds of creams, particularly vanishing creams, and in cosmetics in general.

¹ *J. Am. Chem. Soc.* **52** (1930), 819.

² *J. Chem. Soc.* (1939), 615.

³ *J. Am. Chem. Soc.* **63** (1941), 3526.

⁴ *Ibid.* **62** (1940), 1303.

⁵ *J. Gen. Chem. U.S.S.R.* **9** (1939), 912. *Chem. Abstracts* **34** (1940), 392.

⁶ *J. Am. Chem. Soc.* **61** (1939), 577.

⁷ *J. Chem. Soc.* (1939), 615.

⁸ *Oil and Soap* **17** (1940), 155.

⁹ *Ind. Eng. Chem.* **34** (1942), 1104.

¹⁰ *J. Org. Chem.* **7** (1942), 546; **9** (1944), 329.

¹¹ *Ibid.* **7** (1942), 546.

¹² *J. Chem. Soc.* (1939), 230.

¹³ *Ind. Eng. Chem.* **31** (1939), 309.

¹⁴ *J. Biol. Chem.* **25** (1916), 29.

¹⁵ *Iowa State Coll. J. Sci.* **15** (1941), 226, 228.

¹⁶ *Helv. Chim. Acta* **22** (1939), 1156.

¹⁷ *Oil and Soap* **17** (1940), 155.

(b) UNSATURATED ALIPHATIC ACIDS.

Methacrylic Acid

Mol. Weight 86.09

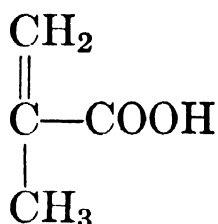

Occurrence.—Studies indicate that this unsaturated acid occurs both free and as ester in Roman chamomile oil.

Isolation and Identification.—For purposes of isolation, the calcium salt is prepared from the hot aqueous solution, the acid set free by hydrochloric acid, extracted with ether, and distilled. Polymerization in the course of distillation should be prevented by the addition of sulfur or diphenylamine, certain metal halides,¹ or hydroquinone.²

Properties.—Fittig and Prehn,³ and Brühl⁴ reported these properties:

m.	16° ³	d_4^{20}	1.0153 ⁴
b.	160.5° (corr.) ³	n_D^{20}	1.43143 ⁴

This acid is very susceptible to polymerization. It undergoes polymerization on distillation, even on long standing, and readily upon addition of a few drops of acid.

Use.—Methacrylic acid, as such, is not used in our industries.

¹ See British Patent No. 456,147, Nov. 3, 1936.

² See French Patent No. 807,222, Jan. 7, 1937.

³ *Liebigs Ann.* **188** (1877), 47.

⁴ *Ibid.* **200** (1880), 181.

Isopropylidenacetic Acid

Mol. Weight 100.11

Senecioic acid. β,β -Dimethylacrylic acid. β -Methylcrotonic acid

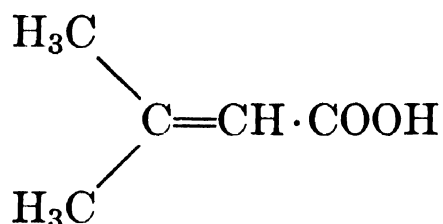

Occurrence.—This unsaturated acid has been observed in oil of masterwort.

Identification.—(1) By preparation of the amide m. 107°–108°, according to de Laet.¹

(2) Condensation with *m*-xylene using aluminum chloride yields 97% of β -(3,5-dimethylphenyl)-isovaleric acid m. 111°–112°, according to Smith and Spillane.²

Properties.—The following properties are reported by Pressman and Lucas,³ Harries and Türk,⁴ Getman,⁵ Crossley and LeSueur,⁶ and Smith, Prichard and Spillane:⁷

m.	66°–67.5° ^{3,7}
b.	199° ⁴
b ₄₀	114° ⁶
d ₄ ^{24.4}	1.0062 ⁵

Use.—Isopropylidenacetic acid is not used in our industries.

¹ *Bull. soc. chim. Belg.* **38** (1929), 166.

² *J. Am. Chem. Soc.* **65** (1943), 202.

³ *Ibid.* **62** (1940), 2078.

⁴ *Liebigs Ann.* **374** (1910), 348.

⁵ *Am. Chem. J.* **44** (1910), 154.

⁶ *J. Chem. Soc.* **75** (1899), 164.

⁷ "Organic Syntheses," Vol. 23 (1943), 28.

Angelic Acid

C₅H₈O₂

Mol. Weight 100.11

Angelica acid. *trans*- α -Methylcrotonic acid. *trans*- α,β -Dimethylacrylic acid

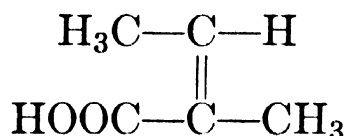

Occurrence.—Angelic acid occurs in Roman chamomile oil and in the distillation waters of angelica root oil.

Identification.—By the preparation of derivatives:

(1) Angelamide m. 127°–128°, according to Naster and Gavriloff.¹

(2) Angelanilide m. 126°–127° (crystallized from benzene), according to Blaise and Bagard.²

Properties.—Angelic acid possesses a somewhat spicy odor. Young, Dillon and Lucas,³ and von Auwers⁴ reported these properties:

m.	45.0°–45.5° ³	d ₄ ^{99.6}	0.9298 ⁴
b _{12–13}	85.5°–87.5° ³	n _{He} ¹⁰⁰	1.4200 ⁴

The acid is sparingly soluble in cold water, readily soluble in hot water, and volatile with steam.

According to the findings of Fittig and co-workers,⁵ angelic acid can be separated from tiglic acid through the difference in the solubility of their calcium salts, that of angelic acid being insoluble in alcohol. Also, this salt

at 60°–70° is much less soluble in water than at room temperature. Therefore, on heating a cold aqueous solution saturated at room temperature, a precipitate will form that will redissolve on cooling—another means of distinguishing angelic acid from tiglic acid.

Use.—Angelical acid is not used in the perfume and flavor industries.

¹ *Bull. soc. chim. Belg.* **42** (1933), 528.

² *Ann. chim. phys.* [8], **11** (1907), 119.

³ *J. Am. Chem. Soc.* **51** (1929), 2531.

⁴ *Liebigs Ann.* **432** (1923), 71.

⁵ *Liebigs Ann.* **283** (1894), 105; **195** (1879), 87.

Tiglic Acid

C₅H₈O₂

Mol. Weight 100.11

cis-α-Methylcrotonic acid. *cis*-α,β-Dimethylacrylic acid

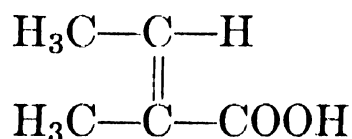

Occurrence.—Tiglic acid occurs in oil of geranium and in oil of anise seed.

Identification.—By the preparation of derivatives:

(1) *p*-Bromophenacyl tiglate m. 67.9° (corr.), according to Lund and Langvad.¹

(2) Tiglamide m. 76.5°–77°, according to Seib.²

(3) Tiglanilide m. 77° (crystallized from petroleum ether), according to the same author.³

Properties.—Tiglic acid possesses a pungent and somewhat spicy odor. The following properties have been recorded by Young, Dillon and Lucas,⁴ and von Auwers:⁵

m.	64° ⁵	d ₄ ^{99.5}	0.9427 ⁵
b ₁₂	94°–96° ⁴	n _{He} ^{99.7}	1.4275 ⁵

The calcium salt of tiglic acid is much more soluble in hot than in cold water and thereby differs from the calcium salt of angelic acid.

Use.—Tiglic acid is used very little in the perfume, soap, and flavor industries.

¹ *J. Am. Chem. Soc.* **54** (1932), 4107.

² *Ber.* **60** (1927), 1396.

³ *Ibid.*

⁴ *J. Am. Chem. Soc.* **51** (1929), 2532.

⁵ *Liebigs Ann.* **432** (1923), 70.

α,β -Hexenic Acid $C_6H_{10}O_2$

Mol. Weight 114.14

 β -Propylacrylic acid

Occurrence.—According to Walbaum and Rosenthal,¹ the highest boiling fractions of Japanese mint oil (*Mentha arvensis*) contain α,β -hexenic acid esterified partly with menthol and partly with *n*-hexenyl alcohol (β,γ -hexenol).

Isolation.—By fractionation of Japanese mint oil and hydrolysis of the esters.

Identification.—Bromination yields α,β -dibromocaproic acid m. 70°, according to Goldberg and Linstead.²

These same authors report the anilide as m. 109°–110°.

Properties.— α,β -Hexenic acid has a somewhat musty, animal-like odor.

Delaby and Guillot-Allègre,^{3,4} Linstead,⁵ and Nenitzescu, Gavat and Cora⁶ reported these properties:

m.	33° ^{3,4,5}
b.	216°–217° ⁵ (corr.) ⁶

According to Goldberg and Linstead,⁷ the α,β acid reaches an equilibrium with the β,γ isomer at 77 per cent of the α,β form. This transformation takes place to some extent near the boiling point of the acid.

Use.—This acid, as such, is not used in our industries.

¹ *Ber. Schimmel & Co., Jubiläums Ausgabe* (1929), 205.

² *J. Chem. Soc.* (1928), 2351.

⁵ *J. Chem. Soc.* (1930), 1609.

³ *Compt. rend.* **192** (1931), 1467.

⁶ *Ber.* **73B** (1940), 233.

⁴ *Bull. soc. chim.* [4], **53** (1933), 301.

⁷ *J. Chem. Soc.* (1928), 2343.

Citronellic Acid $C_{10}H_{18}O_2$

Mol. Weight 170.24

Rhodinic acid. Rhodinolic acid

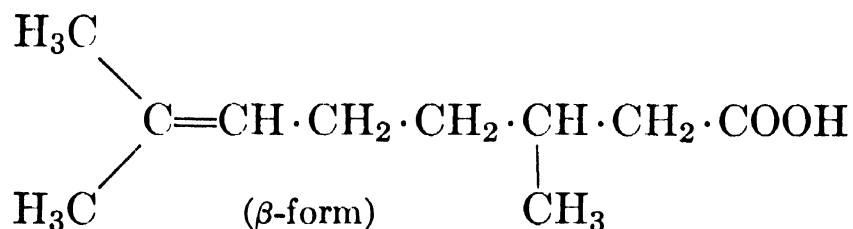

or

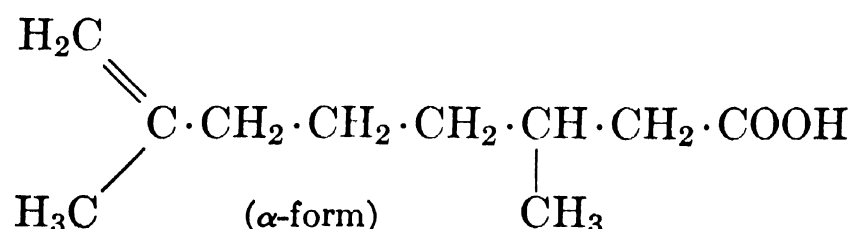

Occurrence.—The *d*-modification of this acid occurs in Java citronella oil and in geranium oil (*Pelargonium graveolens*). The *l*-modification, originally

isolated from "callitris" pine oil by Smith ¹ and described as a phenol ("callitrol"), was later identified in the steam distilled oil from the wood of *Callitris glauca* by Trikojus and White ² and shown to be *l*-citronellic acid. The *d,l*-modification has been reported by Rochussen ³ in camphor oil; however, later findings by Trikojus and White ⁴ indicate that no true racemate of this acid is formed. Gentle oxidation of citronellal yields citronellic acid.

Isolation.—According to Trikojus and White,⁵ the ethereal solution of the steam distilled oil is extracted with 5% sodium hydroxide, the acid precipitated and fractionated several times retaining the fraction $b_{0.5-0.6}$ 116.5°–119°.

Identification.—(1) By the analysis of the silver salt (Ag = 38.99%).

(2) Sabetay ⁶ prepared *d*-citronelloylhydrazides by the action of hydrazine on the free acid. Equal molar quantities of each yield the symmetrical *d*-citronelloylhydrazide m. 139°–140°; while 2 mols of hydrazine and 1 mol of the *d*- acid yield the mono-citronelloylhydrazide m. 83°.

(3) According to Trikojus and White,⁷ citronellic acid gives these color reactions:

With bromine in alcohol—purple on evaporation.

With bromine in acetic acid—red changing to indigo.

With sulfuric acid in acetic acid—red changing to purple.

(4) For further data see section on "Properties."

Properties.—Trikojus and White ⁸ reported these characteristics for a synthetic *d*-citronellic acid and for the natural isolate of the *l*- modification from "callitris" pine oil:

Isomer	b. °C.		α_D (5 cm. tube)	R.I.	
<i>d</i> -Citronellic acid	$b_{0.55}$	118–118.5	+2° 48'	$n_D^{21.5}$	1.4561
<i>l</i> -Citronellic acid (Callitrol)	$b_{0.6}$	117–119	–2° 49' *	n_D^{24}	1.4563

Isomer	Amide m. °C.	Anilide m. °C.	p-Toluidide m. °C.	d	
<i>d</i> -Citronellic acid	84–85	75–76	93–94	d^{20}	0.9308 †
<i>l</i> -Citronellic acid (Callitrol)	84–85	76	93–94	d_{25}^{25}	0.9274

* $[\alpha]_D^{24} = -6° 36'$.

† Heilbron, "Dictionary of Organic Compounds," Vol. I (1943), 558.

In a more recent publication, Okazawa ⁹ reported these melting points of several derivatives of citronellic acid obtained from citronella oil:

Anilide	m. 56°–57°
Nitrosochloride	m. 118°–119°
Nitrosate	m. 120.5°

Okazawa considered his citronellic acid as a mixture of isomers of the limonene and terpinolene type and attempted to separate these isomers by repeated fractional distillation.

Naves, Brus and Allard ¹⁰ described the *d*-citronellic acid from Java citronella oil as follows:

b ₁₀	139°–140°	[α] _j	+7° 20'
d ₄ ²⁰	0.9280	n _D ²⁰	1.4537

These authors pointed out the fact that the acid, as it occurs in this oil, is a mixture of the α- and β- forms with the β- form predominating.

The *d,l*- acid from camphor oil was found by Rochussen ¹¹ to possess these properties:

b ₄	126°	n _D ²⁰	1.46062
d ¹⁵	0.9557	n _D ¹⁵	1.46231

The acid is reported to be nearly odorless when pure and to be completely soluble in sodium carbonate and sodium bicarbonate.

Use.—Citronellic acid, as such, is not used in the perfume or flavor industries; however, in the pharmaceutical trade it has a potential use as it is reported to be toxic to the wood fungus *Fomes annosus*.

¹ *J. Soc. Chem. Ind.* **30** (1911), 1358.

² *J. Proc. Roy. Soc. N. S. Wales* **66** (1932), 284.

³ *J. prakt. Chem.* [2], **105** (1922), 124.

⁴ *J. Proc. Roy. Soc. N. S. Wales* **66** (1932), 284.

⁵ *Ibid.*

⁶ *Compt. rend.* **190** (1930), 1016.

⁷ *J. Proc. Roy. Soc. N. S. Wales* **66** (1932), 284.

⁸ *Ibid.* See also Semmler, *Ber.* **24** (1891), 208; **26** (1893), 2255. Glichitch and Müller, *Chim. et ind.*, April, Special Number (1928), 479. *Ber. Schimmel & Co.*, April (1910), 17.

⁹ *J. Chem. Soc. Japan* **64** (1943), 501, 1360; **65** (1944), 448. *Chem. Abstracts* **41** (1947), 3777.

¹⁰ *Compt. rend.* **200** (1935), 1112.

¹¹ *J. prakt. Chem.* [2], **105** (1922), 124.

The Geranic Acids

Geranic Acid $C_{10}H_{16}O_2$

Mol. Weight 168.23

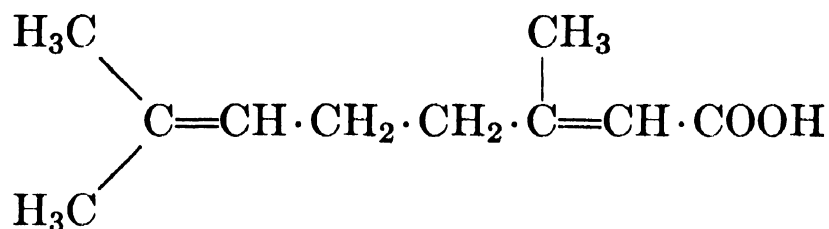
2,6-Dimethyl-1,5-heptadiene-1-carboxylic acid
(β -form)

and

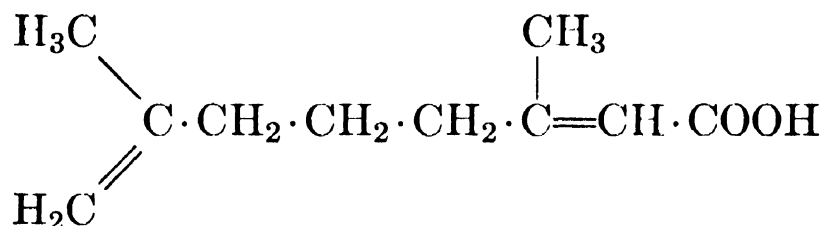
2,6-Dimethyl-1,6-heptadiene-1-carboxylic acid
(α -form)*Dehydrogeranic Acid* $C_{10}H_{14}O_2$

Mol. Weight 166.21

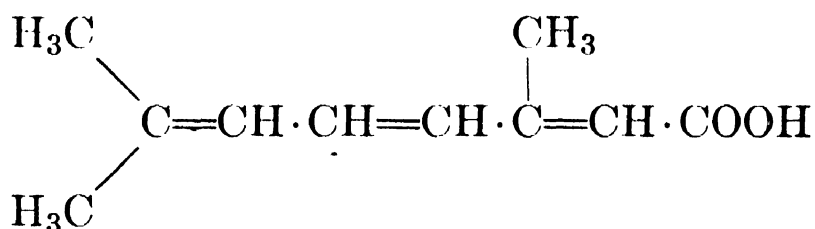
2,6-Dimethyl-1,3,5-heptatriene-1-carboxylic acid. β,ζ -Dimethyl- $\Delta^{\alpha\gamma\epsilon}$ -octatrienoic acid

The naturally occurring geranic acid is composed of the metamers represented above, the β -form predominating.

Cahn, Penfold and Simonsen¹ suggested this structure of dehydrogeranic acid from among the seven theoretically possible formulas, primarily on the basis of the absorption spectra of the compound in ethyl alcohol.

Kuhn and Hoffer,² studying the synthetic preparation of dehydrogeranic acids, came to the conclusion that the natural dehydrogeranic acid is related structurally to geraniol and citral *a*, whereas their synthetic dehydrogeranic acid m. 137° is, on the other hand, related structurally to nerol and citral *b*.

Isopropenyl-isopropylidene isomerism may also occur in this molecule, but the data suggest the β -form as most likely.

Occurrence.—Glichitch and Naves³ identified geranic acid in the saponification products of lemon petitgrain oil. Gentle oxidation of geraniol yields geranic acid.

Cahn, Penfold and Simonsen ⁴ isolated dehydrogeranic acid from the wood oil of *Callitropsis araucarioides* where it occurs as geranyl dehydrogeranate, primarily in the fraction b₃ 115°–125°.

Penfold, Ramage and Simonsen ⁵ detected methyl geranate in the volatile oil derived from the "leafy tops" of the Australian shrub *Calythrix tetragona* (Labillardière) variety "A."

Isolation.—The salt of dehydrogeranic acid is obtained from the geranyl ester by reflux hydrolysis, for 24 hr., with 0.5 N aqueous potassium hydroxide. The free acid can be purified by successive recrystallization from methyl alcohol and ethyl acetate. According to Cahn, Penfold and Simonsen,⁶ it is a colorless solid.

Identification.—

(a) *Geranic acid.* Penfold, Ramage and Simonsen ⁷ identified the natural geranic acid by means of the *p*-phenylphenacyl geranate, m. 79°–80°, and the *p*-bromophenacyl geranate m. 67°.

(b) *Dehydrogeranic acid.* Reduction with palladized charcoal gives *dl*-tetrahydrogeranic acid which yields a *p*-toluidide m. 81°–82°, according to Cahn, Penfold and Simonsen,⁸ and an amide m. 101°–102°.

Properties.—

(a) *Geranic acid.* Von Auwers and Eisenlohr ⁹ described synthetic geranic acid as follows: b₁₄ 158°; d₄^{19.4} 0.9518; n_D^{20.2} 1.48695.

Glichitch and Naves ¹⁰ characterized the geranic acid isolated from lemon petitgrain oil as: b₃ 135°–140°; d₁₅ 0.8694; n₁₅ 1.4804.

According to Tiemann,¹¹ this unsaturated acid decomposes on distillation at ordinary pressures to 2,6-dimethyl-1,5-heptadiene; whereas, on treatment with warm sulfuric and glacial acetic acid, isomerization occurs, to a compound which Bernhauer and Forster ¹² reported as 82 per cent of α -cyclogeranic acid m. 106°.

(b) *Dehydrogeranic acid.* Cahn, Penfold and Simonsen ¹³ noted that the natural isolate decomposes at 185°–186°, and that it is optically inactive in 0.03 per cent sodium hydroxide solutions. It decolorizes potassium permanganate immediately and forms an unstable monobromo-acid. The acid is readily soluble in hot benzene, acetic acid, and methyl alcohol but only sparingly so in these solvents when cold.

Fischer and Löwenburg ¹⁴ reported the *dl*-synthetic β,ζ -dimethyl- $\Delta^{\alpha\gamma\epsilon}$ -octatrienoic acid as melting at 187°–188°.

These authors further observed that dehydrogeranic acid, when heated to 50°–95°, loses carbon dioxide and forms the easily polymerized β,ζ -dimethyl- $\Delta^{\alpha\gamma\epsilon}$ -heptatriene b₁₀ 53°–54°, m. –23° to –22°.

A density determination was conducted by Owen and Pickup ¹⁵ who observed 1.10 for the crystal.

Use.—Geranic and dehydrogeranic acids, as such, are not used in our industries.

Roger and Dvolaitzkaya ¹⁶ explored the use of heptyl geranate in perfumes.

- ¹ *J. Chem. Soc.* (1931), 3134.
² *Ber.* **65** (1932), 655, 658; **63** (1930), 2170.
³ *Parfums France* **7** (1929), 60.
⁴ *J. Chem. Soc.* (1931), 3134.
⁵ *J. Proc. Roy. Soc. N. S. Wales* **68** (1934), 80.
⁶ *J. Chem. Soc.* (1931), 3139.
⁷ *J. Proc. Roy. Soc. N. S. Wales* **68** (1934), 80.
⁸ *J. Chem. Soc.* (1931), 3140.
⁹ *J. prakt. Chem.* [2], **84** (1911), 22.
¹⁰ *Parfums France* **7** (1929), 64.
¹¹ *Ber.* **31** (1898), 827. Cf. also Henne and Chanan, *J. Am. Chem. Soc.* **66** (1944), 394.
¹² *J. prakt. Chem.* **147** (1937), 199. Cf. Glichitch and Naves, *Parfums France* **7** (1929), 60.
¹³ *J. Chem. Soc.* (1931), 3139.
¹⁴ *Liebigs Ann.* **494** (1932), 282. Cf. Fischer and Hultzs, *Ber.* **68** (1935), 1726.
¹⁵ Reported in paper by Cahn, Penfold and Simonsen, *J. Chem. Soc.* (1931), 3137.
¹⁶ *Recherches* **1** (1937), 79. *Chem. Abstracts* **32** (1938), 1241.

Oleic Acid

C₁₈H₃₄O₂

Mol. Weight 282.45

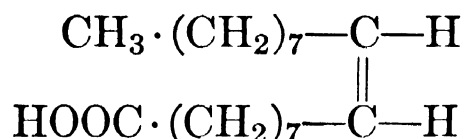

Occurrence.—Oleic acid occurs in oil of orris root and in a few other essential oils.

Identification.—By the preparation of derivatives:

(1) *p*-Bromophenacyl oleate m. 46° and *p*-phenylphenacyl ester m. 61°, according to Kimura.¹

(2) *p*-Chloropseudothiuronium oleate m. 131°, by Dewey and Sperry.²

(3) *p*-Bromobenzylpseudothiuronium oleate m. 133°, by Dewey and Shasky.³

Properties.—Physical properties for highly purified oleic acid have been reported by Smith,⁴ and by Wheeler and Riemenschneider:⁵

f.p.	13.34° ⁴ (α - form)	n _D ²⁵	1.4581 ⁵
m.	13.36° ⁴ (α - form)	n _D ²⁰	1.4597 ⁴
	16.25° ⁴ (β - form)	n _D ¹⁵	1.4616 ⁴
	Iodine No. (Wijs, ½ hr.)	90.0 ⁵	
	Thiocyanogen No. (3 hr.)	89.6 ⁵	

Oleic acid is insoluble in water, and miscible with alcohol or ether. On distillation at atmospheric pressure, oleic acid decomposes but it can be distilled with superheated steam at 250°. Oleic acid crystallizes first as α - form, but on standing this form changes gradually into the stable β - form which, according to Smith,⁶ crystallizes only slowly.

Ravich, Volkova and Kuz'mina⁷ investigated the polymorphic properties of this acid and reported the melting points of unstable varieties at 8.5° and 11.0°.

Smith,⁸ Wheeler and Riemenschneider,⁹ and Brown¹⁰ all contributed to the method and knowledge of low temperature crystallization as a special means of purification of oleic acid.

Stewart and Wheeler¹¹ prepared binary mixtures of oleic with linoleic and linolenic acid and studied their properties as a means of analyzing mixtures of these acids.

Use.—Oleic acid is used mainly as an ingredient in cosmetics, especially facial creams. It also serves as an emulsifying agent. Oleic acid furthermore forms the base of many types of soaps.

¹ *J. Soc. Chem. Ind. Japan* **35**, Suppl. binding (1932), 221.

² *J. Am. Chem. Soc.* **61** (1939), 3251.

³ *Ibid.* **63** (1941), 3526.

⁴ *J. Chem. Soc.* (1939), 978.

⁵ *Oil and Soap* **16** (1939), 209.

⁶ *J. Chem. Soc.* (1939), 978.

⁷ *Compt. rend. acad. sci. U.S.S.R.* **29** (1940), 88. *Acta physicochim. U.S.S.R.* **14** (1941), 403. *Chem. Abstracts* **35** (1941), 2782, 5369.

⁸ *J. Chem. Soc.* (1939), 974.

⁹ *Oil and Soap* **16** (1939), 209.

¹⁰ *Chemical Reviews* **29** (1941), 333.

¹¹ *Oil and Soap* **18** (1941), 69.

SUGGESTED ADDITIONAL LITERATURE

H. Fiedler, "Zur stereochemischen Konfiguration der Ölsäure," *Fette und Seifen* **47** (1940), 219.

(c) DIBASIC ALIPHATIC ACIDS.

Succinic Acid

$C_4H_6O_4$

Mol. Weight 118.09

Ethane-1,2-dicarboxylic acid

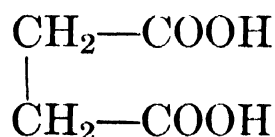

Occurrence.—This dibasic acid has been observed as a natural constituent in the wood of *Goupia tomentosa*.

Identification.—By the preparation of derivatives:

(1) *p*-Chlorobenzylpseudothiuronium succinate m. 167°, by Dewey and Sperry;¹ and the corresponding bromo derivative m. 167°, according to Dewey and Shasky.²

(2) Mono-*p*-toluidide, m. 177°–178°, according to Pucher and Vichery.³

(3) Di-phenacyl succinate m. 148°, according to Rather and Reid.⁴ This compound is useful for the identification of succinic acid in the presence of acetic acid, citric acid, *l*-malic acid, oxalic acid, or *d*-tartaric acid.

(4) Di-*p*-bromophenacyl succinate m. 211°, according to Judefind and Reid;⁵ and methyl-*p*-bromophenacyl succinate m. 104.6°–104.8°, by Mowry and Brode.⁶

Properties.—Viseur ⁷ and Biltz ⁸ recorded these properties:

m.	182.7° ⁷
d ₄ ²⁵	1.572 ⁸

Wright ⁹ reported the solubilities (g. per 100 g. of solvent) of succinic acid in water and absolute alcohol:

	20°	30°
Water	6.8 g.	10.5 g.
Absolute Alcohol	10.0 g.	12.0 g.

The silver salt of succinic acid is insoluble in cold water. The calcium salt containing 3 mols of water precipitates at room temperature; the calcium salt containing 1 mol of water precipitates at the boiling point, but with calcium chloride only from concentrated solutions of alkali succinates.

Use.—Succinic acid is used mainly for the preparation of esters which serve as diluents of perfume compositions and occasionally as adulterants of essential oils.

¹ *J. Am. Chem. Soc.* **61** (1939), 3251.

² *Ibid.* **63** (1941), 3526.

³ *Ind. Eng. Chem., Anal. Ed.* **13** (1941), 414.

⁴ *J. Am. Chem. Soc.* **41** (1919), 83.

⁵ *Ibid.* **42** (1920), 1055.

⁶ *Ibid.* **63** (1941), 2281.

⁷ *Bull. soc. chim. Belg.* **35** (1926), 427.

⁸ *Liebigs Ann.* **453** (1927), 278.

⁹ *J. Chem. Soc.* (1927), 1336.

SUGGESTED ADDITIONAL LITERATURE

L. M. Kulberg, "Micro-determination of Acids by Titration with Sodium Phenolphthaleinate," *Zavodskaya Lab.* **7** (1938), 417.

George J. Goepfert, "A Micro-determination of Succinic Acid," *Biochem. J.* **34** (1940), 1012.

(d) ALIPHATIC HYDROXY ACIDS.

Hydroxymyristic Acid

C₁₄H₂₈O₃

Mol. Weight 244.36

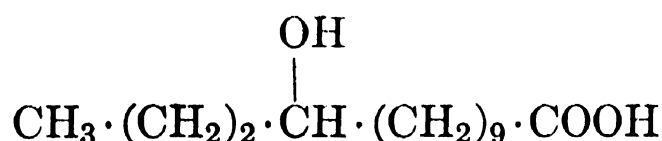

Occurrence.—This acid has been observed in the high boiling fractions of the oils derived from angelica seed, and from sabadill. Although its constitution has not been firmly established, a hydroxymyristic acid of similar prop-

erties was prepared by Asahina and co-workers¹ and identified as 10-hydroxytridecan-carboxylic acid.

Identification.—By the preparation of benzoylhydroxymyristic acid m. 68°, according to Müller.²

Properties.—M. 51° (Müller). Asahina et al.³ obtained sebacic and butyric acids by oxidation of their hydroxymyristic acid. The acid is not easily soluble in hot water. The derived keto acid from 10-hydroxymyristic acid melts at 66°–67°, and yields a semicarbazone m. 100°.

Use.—Hydroxymyristic acid is not used in the perfume and flavor industries.

¹ *J. Pharm. Soc. Japan* **520** (1925), 2; **479** (1922), 1. *Chem. Zentr.* I (1926), 135; I (1922), 976.

² *Ber.* **14** (1881), 2483.

³ *J. Pharm. Soc. Japan* **520** (1925), 2; **479** (1922), 1. *Chem. Zentr.* I (1926), 135; I (1922), 976.

15-Hydroxypentadecylic Acid

C₁₅H₃₀O₃

Mol. Weight 258.39

15-Hydroxypentadecanoic acid

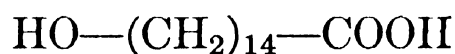

Occurrence.—The constitution of this acid, which occurs, according to Ciamician and Silber,¹ as lactone in the high boiling fractions of angelica root oil, was established by Kerschbaum.² Casparis and Freund³ identified this acid in the fixed oil of juniper berries.

Identification.—By preparation of these derivatives:

(1) Acethydroxypentadecylic acid m. 59.4°–59.6°, by Chuit and Hausser.⁴

(2) 15-Bromopentadecylic acid m. 66°, according to Hunsdiecker and Hunsdiecker.⁵ 15-Iodopentadecylic acid m. 77°, by the same authors.

(3) The methyl ester was observed by Chuit and Hausser⁶ as m. 52°–52.5°, b₂ 180°–182°.

Properties.—When crystallized from ether, this acid forms star-like needles m. 84.8°–85.2°, according to Chuit and Hausser.⁷

Insoluble in water, slightly soluble in ligroine, easily soluble in alcohol, ethyl acetate, acetone, and benzene.

According to Ruzicka and Stoll,⁸ oxidation with chromic acid in acetic acid yields tridecan-dicarboxylic acid, m. 112°–113°.

Ring closure leads to the musk lactone exaltolide m. 31°–32°, d₄⁴¹ 0.9383, n_D⁴¹ 1.4633, according to Ruzicka and Stoll;⁹ while Stoll and Rouvé¹⁰ reported m. 30°–31°, b_{0.06} 111°–112°, d₄³³ 0.9462, n_D³¹ 1.4670, saponification number 233.4.

Use.—Hydroxypentadecylic acid, as such, is not used in the perfume or flavor industries. However, the lactone of this acid has attained considerable importance (see “Exaltolide”).

- ¹ *Ber.* **29** (1896), 1811.
² *Ber.* **60** (1927), 903.
³ *Pharm. Acta Helv.* **13** (1938), 307. *Chem. Abstracts* **34** (1940), 849.
⁴ *Helv. Chim. Acta* **12** (1929), 484. Cf. Ciamician and Silber, *Ber.* **29** (1896), 1811.
⁵ *Ber.* **75B** (1942), 294. Cf. Chuit and Hausser, *Helv. Chim. Acta* **12** (1929), 484; and Ciamician and Silber, *Ber.* **29** (1896), 1811.
⁶ *Helv. Chim. Acta* **12** (1929), 484.
⁷ *Ibid.*, 483.
⁸ *Ibid.* **11** (1928), 1167.
⁹ *Ibid.*
¹⁰ *Ibid.* **17** (1934), 1288.

SUGGESTED ADDITIONAL LITERATURE

Otto Gerhardt, "Higher-ring Ketones and Lactones. (Exaltone and Exaltolide)," *Seifensieder-Ztg.* **62** (1935), 169.

Ambrettolic Acid

C₁₆H₃₀O₃

Mol. Weight 270.4

16-Hydroxy-7-hexadecenoic acid

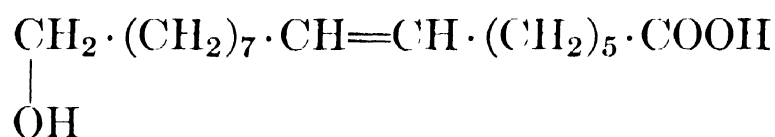

Occurrence.—Ambrettolic acid occurs mainly as ester in oil of ambrette seed.

Isolation.—Stoll and Gardner¹ isolated the acid from the neutral fraction b_{0.3} 90°–137°. After saponification of this fraction, the aqueous solution was extracted repeatedly with ether and acidified with hydrochloric acid. The resulting acid, nearly insoluble in petroleum ether, is further purified through its barium salt, a method developed earlier by Kerschbaum.²

Properties.—M. 25°, according to Kerschbaum,³ m. 20°–22° by Stoll and Gardner.⁴

On treatment with acids or on warming, even in a vacuum desiccator at room temperature, ambrettolic acid is converted into a lactone, viz., ambrettolide, which can be distinguished by its typical musk odor. Lactonization by the method of Stoll and Rouvé⁵ yields pure ambrettolide, according to Stoll and Gardner.⁶ Reduction forms a dihydroambrettolic acid identical with Bougault and Bourdier's⁷ juniperic acid, m. 95°.

Use.—Ambrettolic acid, as such, is not used in our industries.

- ¹ *Helv. Chim. Acta* **17** (1934), 1611.
² *Ber.* **60** (1927), 902.
³ *Ibid.*, 904.
⁴ *Helv. Chim. Acta* **17** (1934), 1611.
⁵ *Ibid.*, 1283.
⁶ *Ibid.*, 1611.
⁷ *J. pharm. chim.* [6], **29** (1909), 561.

B. AROMATIC ACIDS

Benzoic Acid

C₇H₆O₂

Mol. Weight 122.12

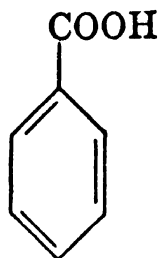

Occurrence.—Benzoic acid has been found in quite a number of essential oils—for example, in oil of cinnamon leaves, anise seed, clove, cassia, neroli bigarade, tolu balsam, vetiver, ylang ylang, and in a few flower oils, such as tuberose, hyacinth and champaca.

Identification.—(1) By use of the microchemical test of Shupe¹ wherein the acid is treated with a 5% silver nitrate solution in 2% triethanolamine. The zinc-pyridine reagent or a lead-triethanolamine solution yields crystalline precipitates characteristic for benzoic acid; Huijsse² employs the copper-pyridine reagent for this acid.

(2) 4-(4'-Bromophenyl)-phenyl benzoate m. 192°–193°, by Hazlet, Alliger and Tiede.³

(3) Phenyl mercury salt (Bz·O·Hg·Ph) m. 97°–98°, according to Koton;⁴ it is prepared directly by the action of diphenyl mercury on the acid.

(4) *p*-Iodophenylurea m. 247°–248° (corr.) derived from the reaction of *p*-iodobenzazide and benzamide in boiling toluene, according to Sah and Wang.⁵ Although an indirect derivative of the acid, it is nevertheless to be recommended because of the high yield and low solubility of the urea. Benzamide m. 130°, according to Huntress and Mulliken.⁶

(5) Another indirect but equally useful derivative is the benzylamide m. 105°–105.5° from the interaction of the esters of benzoic acid and benzylamine, according to Dermer and King.⁷

(6) *p*-Bromobenzylpseudothiuronium benzoate m. 154°, by Dewey and Shasky.⁸

(7) *p*-Chlorophenacyl benzoate m. 118.6°, according to Judefind and Reid.⁹

(8) *p*-Phenylphenacyl benzoate m. 167°, according to Drake and Bronitsky.¹⁰

Properties.—The following properties are reported by Schwab and Wichers,¹¹ and Landee and Johns:¹²

f.p.	122.36 ± .01° ¹¹
b.	249° ¹²

Benzoic acid sublimes even at 100°; it is readily volatile with steam; 0.27 g. are soluble in 100 g. of water at 18°. Soluble in 2.14 parts of absolute alcohol at 15°.

Extensive careful studies have been carried out by Nicolescu and Klang¹³ also on the solubilities of benzoic acid in numerous other solvents.

Use.—Benzoic acid is used mainly for the preparation of esters and for chemical synthesis in general. It has also attained some importance as a

preservative of fruit juices and pharmaceutical preparations which readily spoil by bacterial action.

- ¹ *J. Assocn. Official Agr. Chem.* **21** (1938), 528.
- ² *Tijdschr. Artenijkunde* **1** (1943), 218. *Chem. Zentr.* II (1943), 548.
- ³ *J. Am. Chem. Soc.* **61** (1939), 1447.
- ⁴ *J. Gen. Chem. U.S.S.R.* **9** (1939), 912. *Chem. Abstracts* **34** (1940), 392.
- ⁵ *Rec. trav. chim.* **59** (1940), 364.
- ⁶ "Identification of Pure Organic Compounds," Order I, New York, Wiley (1941), 146.
- ⁷ *J. Org. Chem.* **8** (1943), 168.
- ⁸ *J. Am. Chem. Soc.* **63** (1941), 3526.
- ⁹ *Ibid.* **42** (1920), 1054.
- ¹⁰ *Ibid.* **52** (1930), 3719.
- ¹¹ *J. Research Nat'l Bureau Standards* **25** (1940), 757.
- ¹² *J. Am. Chem. Soc.* **63** (1941), 2891.
- ¹³ *Bul. chim. soc. chim. România* [2], **1** (1939), 146. *Chem. Abstracts* **37** (1943), 3320.

Phenylacetic Acid

$C_8H_8O_2$

Mol. Weight 136.14

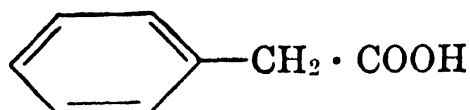

Occurrence.—Phenylacetic acid occurs free and as ester in Japanese mint oil (*Mentha arvensis*), and in oil of neroli bigarade. It is present probably also in other volatile oils.

Identification.—(1) On warming with dilute sulfuric acid and manganese dioxide, phenylacetic acid develops an odor of benzaldehyde.

(2) By the preparation of derivatives:

- (a) *p*-Nitrobenzyl phenyl acetate m. 65° , according to Lyman and Reid.¹
- (b) Phenylacetanilide m. 117° – 118° , according to Reissert and More.²
- (c) Phenylaceto-*p*-toluidide m. 135° – 136° , according to Purgotti.³
- (d) Salt and amide from dodecylamine: respectively, m. 68.5° – 69.5° and m. 79° – 79.5° (Hunter⁴).
- (e) The benzylamide m. 121° – 122° is prepared directly from the ester by the action of benzylamine, according to Dermer and King.⁵

Properties.—Phenylacetic acid possesses a peculiar, lasting odor. Möller and Strecker,⁶ and Adams and Thal⁷ recorded these properties:

m. 76° – 76.5° ^{6,7}

b. 265.5° ⁶

Phenylacetic acid is easily soluble in hot water, sparingly soluble in cold water; very soluble in alcohol or ether. It sublimes readily.

Use.—Phenylacetic acid is used mainly for the preparation of esters, especially methyl and ethyl esters, which are characterized by their strong odor reminiscent of honey, and which serve in numerous perfume and flavor compositions. Because of their odor strength and low price, these esters are also used as adjuncts in the scenting of soaps.

¹ *J. Am. Chem. Soc.* **39** (1917), 710.

² *Ber.* **39** (1906), 3307.

³ *Gazz. chim. ital.* **20** (1890), 178.

⁴ *Iowa State College J. Sci.* **15** (1941), 228.

⁵ *J. Org. Chem.* **8** (1943), 168.

⁶ *Liebigs Ann.* **113** (1860), 65.

⁷ "Organic Syntheses," Coll. Vol. I, New York, John Wiley (1941), 436.

Cinnamic Acid

$C_9H_8O_2$

Mol. Weight 148.15

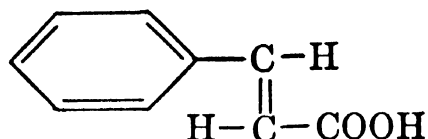

Occurrence.—Cinnamic acid occurs in nature predominately as the *trans*-isomer.

Cinnamic acid has been observed in Asiatic and American styrax oil, in oil of cassia, balsam of Peru, basil, and in a few other essential oils.

Identification.—By the preparation of derivatives:

(1) *p*-Nitrobenzyl cinnamate m. 116.8°, according to Lyman and Reid.¹

(2) Phenacyl cinnamate m. 140.5°, according to Rather and Reid.²

(3) *p*-Bromobenzylpseudothiuronium cinnamate m. 170°, by Dewey and Shasky;³ the corresponding chloro compound m. 167°, by Dewey and Sperry.⁴

Properties.—Dippy and Lewis⁵ reported the melting point of a highly purified *trans*- product as 136.5°, the *cis*- or *allo*- form melting at 68°.

Gross, Saylor and Gorman⁶ determined the solubility of cinnamic acid in water as 0.604 g. per 1000 g. of solvent, while Desai and Patel⁷ investigated the solubility of this acid in numerous organic solvents. These authors found ~ 0.08 mol of acid to be soluble per mol of alcohol. The acid is somewhat soluble in hot water, readily soluble in ether, insoluble in petroleum ether.

Use.—Cinnamic acid serves mainly for the preparation of esters which are used in perfumes, cosmetics, and for the scenting of soaps.

¹ *J. Am. Chem. Soc.* **39** (1917), 703.

² *Ibid.* **41** (1919), 81.

³ *Ibid.* **63** (1941), 3526.

⁴ *Ibid.* **61** (1939), 3251.

⁵ *J. Chem. Soc.* (1937), 1010.

⁶ *J. Am. Chem. Soc.* **55** (1933), 650.

⁷ *J. Indian Chem. Soc.* **12** (1935), 131.

SUGGESTED ADDITIONAL LITERATURE

P. Mastagli and M. Métayer, "Hydrogenation of Cinnamic Acid and *p*-Hydroxycinnamic Acid with Raney Nickel," *Compt. rend.* **224** (1947), 1779. *Chem. Abstracts* **42** (1948), 1243.

Salicylic Acid

C₇H₆O₃

Mol. Weight 138.12

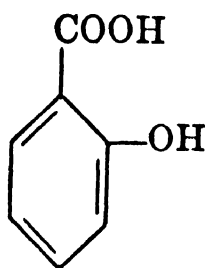
o-Hydroxybenzoic acid

Occurrence.—Salicylic acid has been identified in oil of ylang ylang, cassia, American pennyroyal, anise seed, and several other essential oils. As methyl ester it is widely distributed in nature.

Identification.—(1) On warming with concentrated sulfuric acid and methyl alcohol, salicylic acid or its salts develop the characteristic odor of wintergreen oil (methyl salicylate).

(2) Kul'berg and Presman¹ found that salicylic acid develops a yellow color in concentrations of 1 part per million, with ammoniumpersulfate.

(3) By the preparation of derivatives:

(a) *p*-Bromophenacyl salicylate m. 140°, according to Judefind and Reid.²

(b) Salicylanilide m. 134°–135° (prepared by heating salicylic acid with aniline in the presence of phosphorus trichloride PCl₃), according to Hübner.³

(c) *S*-benzyl thiuronium salicylate m. 146° (Donleavy⁴).

(d) 3,5-Dinitrobenzoyl methyl salicylate m. 107.5° from sodium methyl salicylate and 3,5-dinitrobenzoyl chloride (Saunders, Stacey and Wilding⁵).

(e) *p*-Chlorobenzylpseudothiuronium salicylate m. 162° (Dewey and Sperry⁶). The corresponding bromo compound melts at 168° (Dewey and Shasky⁷).

Properties.—The United States Pharmacopoeia, Twelfth Revision, and Cohen and Blekkingh, Jr.⁸ recorded these properties:

m. 158°–160°
d²⁵ 1.4340

Salicylic acid is slightly soluble in water (0.124 g. in 100 g. of water at 0° and 7.5 g. at 100°, according to Savarro⁹); it is readily soluble in alcohol or ether. However, figures as to solubility should be accepted with caution, since Thiessen and Koerner,¹⁰ reported their observations on the relation of solubility to polymorphism in this acid. The acid is volatile with steam. Moreover, it sublimates at 70°–85° without decomposition, according to Binova and Raĭgorodska,¹¹ but decomposition takes place with sublimation in the range 100°–150° as observed by Hirsbrunner.¹²

Use.—Salicylic acid is used for the synthesis of many important compounds—*aspirin*, for example. In our industry it serves mainly for the preparation of esters, methyl salicylate in particular. Because of its antiseptic properties,

salicylic acid is also used for the preservation of fruit juices and generally in pharmaceutical preparations.

- ¹ *Farm. Zhur.* **13**, No. 1 (1940), 17. *Chem. Abstracts* **36** (1942), 7234.
- ² *J. Am. Chem. Soc.* **42** (1920), 1049.
- ³ *Liebigs Ann.* **210** (1881), 342.
- ⁴ *J. Am. Chem. Soc.* **58** (1936), 1004.
- ⁵ *Biochem. J.* **36** (1942), 373.
- ⁶ *J. Am. Chem. Soc.* **61** (1939), 3251.
- ⁷ *Ibid.* **63** (1941), 3526.
- ⁸ *Proc. Acad. Sci. Amsterdam* **38** (1935), 842, 978. *Chem. Abstracts* **30** (1936), 2069.
- ⁹ *Atti. Accad. Torino* **48** (1913), 955.
- ¹⁰ *Z. anorg. allgem. Chem.* **197** (1931), 307.
- ¹¹ *Farm. Zhur.* (1934), 30. *Chem. Abstracts* **28** (1934), 3691.
- ¹² *Helv. Chim. Acta* **17** (1934), 477.

p-Anisic Acid

$C_8H_8O_3$

Mol. Weight 152.14

p-Methoxybenzoic acid



Occurrence.—Anisic acid is found in most essential oils containing a high percentage of anethole, from which it may originate by gradual oxidation on aging. Anisic acid has also been identified in Tahiti vanilla beans. Recently Lederer¹ observed it in castoreum.

Identification.—By the preparation of derivatives:

- (1) *p*-Nitrobenzyl anisate m. 132°, according to Lyons and Reid.²
- (2) Anisanilide m. 168°–169°, according to Haller,³ and Lossen.⁴
- (3) Benzylamide of the acid, m. 131°–132.5°, by Dermer and King,⁵ prepared from the methyl ester of anisic acid and benzylamine.

Properties.—Gilman, Langham and Willis,⁶ Persoz,⁷ and Nozu, Hamada, Hosino and Kinoshita⁸ recorded these properties:

m. 183°–184°^{6,8}
b. 275°–280°⁷

p-Anisic acid is sparingly soluble in cold water. (1 liter water dissolves 0.27 g. of the acid at 18°, according to Berthelot.⁹) Cahours¹⁰ reports the acid as easily soluble in alcohol or ether, and fairly so in hot water.

The acid gives a characteristic micro crystalline salt with the copper-pyridine reagent, according to Huijsse.¹¹

Use.—*p*-Anisic acid as such, is not used in our industries.

- ¹ *Trav. membres soc. chim. biol.* **23** (1941), 1457. *Chem. Abstracts* **39** (1945), 1448.
- ² *J. Am. Chem. Soc.* **39** (1917), 1738.
- ³ *Compt. rend.* **121** (1895), 190.

- ⁴ *Liebigs Ann.* **175** (1875), 292.
⁵ *J. Org. Chem.* **8** (1943), 168.
⁶ *J. Am. Chem. Soc.* **62** (1940), 347.
⁷ *Liebigs Ann.* **44** (1842), 311.
⁸ *J. Chem. Soc. Japan* **60** (1939), 1189. *Chem. Abstracts* **36** (1942), 6513.
⁹ *Ann. chim. phys.* [6] **7** (1886), 180.
¹⁰ *Liebigs Ann.* **41** (1842), 66.
¹¹ *Tijdschr. Artsenijkunde* **1** (1943), 218. *Chem. Zentr.* II (1943), 548.

Piperonylic Acid

C₈H₆O₄

Mol. Weight 166.13

3,4-Methylenedioxybenzoic acid

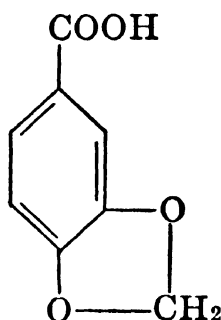

Occurrence.—In oil of camphor, and pha-chium.

Identification.—(1) By the preparation of piperonylamide m. 169° (anhydrous tablets from alcohol), according to Rupe and v. Majewski.¹

(2) By means of the benzylamide of piperonylic acid, m. 126.5°–127.5°. Prepared by the action of benzylamine on the methyl ester of piperonylic acid, according to Dermer and King.² This same derivative and several other N-substituted piperonylamides are reported by Gertler and Haller;³ they include the *o*-tolyl piperonylamide m. 137.5°–138.5°, the *m*-isomer m. 121°–122°, and the *p*-isomer m. 149°–149.5°. These authors prepared this series of compounds from piperonyl chloride and the appropriate amine.

Properties.—Shriner and Kleiderer⁴ reported the melting point as 227°–228°.

According to Fittig and Mielch,⁵ piperonylic acid is insoluble in cold water or chloroform, and sparingly soluble in cold alcohol or ether. Jobst and Hesse⁶ observed that piperonylic acid sublimes on slow heating at 210°.

Use.—Piperonylic acid, as such, is not used in our industries but certain of its nitrogen derivatives have been explored as pyrethrum synergists.

¹ *Ber.* **33** (1900), 3403.

² *J. Org. Chem.* **8** (1943), 168.

³ *J. Am. Chem. Soc.* **64** (1942), 1741.

⁴ "Organic Syntheses," Col. Vol. II, New York, John Wiley, 538.

⁵ *Liebigs Ann.* **152** (1869), 40.

⁶ *Ibid.* **199** (1879), 63.

Veratric Acid

 $C_9H_{10}O_4$

Mol. Weight 182.17

3,4-Dimethoxybenzoic acid

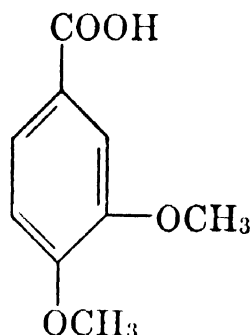

Occurrence.—Veratric acid has been observed in oil of sabadill where it occurs probably as methyl and ethyl ester.

Identification.—Veratric acid may be identified by the preparation of these derivatives:

(1) Amide m. 164° , from the action of ammonia on veratroyl chloride, according to Meyer.¹

(2) 6-Bromoveratric acid m. 183° – 184° , according to Matsumoto.²

(3) Freudenburg and Jakob³ prepared the methyl ester m. 62° by the reaction of 2 g. of veratric acid, 40 cc. of methyl alcohol, and 0.3 g. of acetyl chloride for 24 hr. at 20° . The resulting ester is vacuum dried and recrystallized from methanol. Methyl veratrate b₁₅ 165° , according to Arnold and Bordwell.⁴

Properties.—Matsumoto⁵ observed that this acid crystallizes as a monohydrate from its aqueous solutions at temperatures below 50° , whereas the anhydrous veratric acid is obtained when crystallization results above 50° C.

Goldschmiedt⁶ reported the anhydrous acid as melting at 181° . These melting points have been subsequently confirmed by Freudenburg, Meister and Flickinger,⁷ Grignard,⁸ Nierenstein,⁹ and Oliverio.¹⁰

Rodionov and Fedorova¹¹ observed rhombic crystals of the sublimed acid as melting at 178° – 179° .

One part of veratric acid is soluble in 2100–2150 parts of water at 14° and in 160–165 parts at 100° , according to Matsumoto.¹²

Graebe and Borgmann¹³ noted that the acid is easily soluble in alcohol and ether.

Use.—Veratric acid, as such, is not used in the perfume or flavor industries.

¹ *Monatsh.* **22** (1901), 429.

² *Ber.* **11** (1878), 126. Cf. Raiford and Perry, *J. Org. Chem.* **7** (1942), 354.

³ *Ber.* **74** (1941), 1001.

⁴ *J. Am. Chem. Soc.* **64** (1942), 2983.

⁵ *Ber.* **11** (1878), 124.

⁶ *Monatsh.* **6** (1885), 379.

⁷ *Ber.* **70** (1937), 512.

⁸ *Compt. rend.* **198** (1934), 625.

⁹ *J. Am. Chem. Soc.* **52** (1930), 4012.

¹⁰ *Boll. sedute accad. gioenia sci. nat. Catania* **3**, No. 5 (1937). *Chem. Zentr.* I (1939), 2594.

¹¹ *Arch. Pharm.* **271** (1933), 287.

¹² *Ber.* **11** (1878), 124.

¹³ *Liebigs Ann.* **158** (1871), 282.

Trimethylgallic Acid

C₁₀H₁₂O₅

Mol. Weight 212.20

3,4,5-Trimethoxybenzoic acid

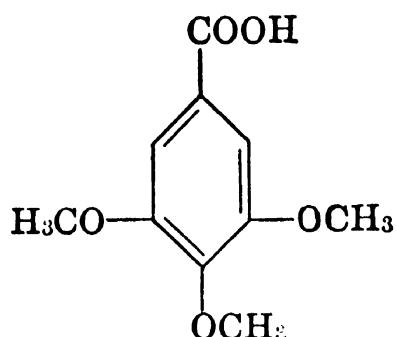

Occurrence.—Trimethylgallic acid has been observed in oil of *Boronia pinata* Smith.

Isolation.—The acid is readily isolated as sodium salt and freed by precipitation with hydrochloric acid. Trimethylgallic acid is further purified by recrystallization from boiling water and treatment of the solution with decolorizing carbon.

Identification.—(1) As methyl ester m. 81°, b. 274°–275°, according to Will.¹

(2) As phenyl ester m. 103° (Pepe).²

(3) Trimethylgallic hydrazide, prepared from the methyl ester and hydrazine hydrate in methanol, crystallizes with 1 mol of solvent. It melts at 128°–129° and after vacuum drying at 100°, m. 168°, according to Buchanan, Cook and Loudon.³ This hydrazide is converted to the azide by the action of nitric acid (Pepe).⁴

(4) With α - and β -naphthols the azide yields the corresponding trimethylgallates m. 155° and 127°, respectively (Pepe).⁵

With *o*-, *m*-, and *p*-cresols the azide of trimethylgallic acid yields the *o*-, *m*-, and *p*-cresyl esters: *o*-tolyl trimethylgallate m. 102°; *m*- isomer m. 124°; *p*- isomer m. 89°, according to Pepe.⁶

Properties.—Nierenstein⁷ reported the pure acid as melting at 169° with evolution of carbon dioxide.

3,4,5-Trimethoxybenzoic acid is not so sensitive to oxidation as gallic acid.

Use.—Trimethylgallic acid is not used in the perfume or flavor industries.

¹ *Ber.* **21** (1888), 2022.

² *J. prakt. Chem.* **126** (1930), 243.

³ *J. Chem. Soc.* (1944), 327.

⁴ *J. prakt. Chem.* **126** (1930), 241. Cf. *Anales asoc. quim. Argentina* **26** (1938), 51. *Chem. Abstracts* **33** (1939), 171.

⁵ *Anales asoc. quim. Argentina* **28** (1940), 143. *Chem. Abstracts* **35** (1941), 2882.

⁶ *Anales asoc. quim. Argentina* **29** (1941), 124. *Chem. Abstracts* **36** (1942), 440.

⁷ *J. Am. Chem. Soc.* **52** (1930), 4012.

SUGGESTED ADDITIONAL LITERATURE

F. Mauthner, "Trimethylgallic Acid," "Organic Syntheses," Coll. Vol. I, Wiley (1941), p. 537.

Morris and Riemenschneider, "Higher Fatty Alcohol Esters of Gallic Acid," *J. Am. Chem. Soc.* **68** (1946), 500.

***p*-Methoxycinnamic Acid**C₁₀H₁₀O₃

Mol. Weight 178.18

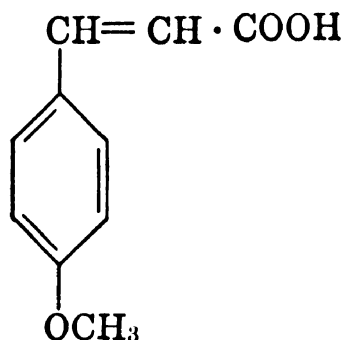
p-Coumaric acid methyl ether

Occurrence.—The ethyl ester of this acid was first reported by Thresh¹ in the oil derived from the rhizome of *Hedychium spicatum* Ham. (fam. *Zingiberaceae*). According to van Romburgh,² and Panicker, Rao and Simonsen,³ the ethyl ester also occurs in oil of *Kaempferia galanga* L.

Power and Rogerson⁴ identified the acid in the hydrolyzed alcoholic extract from the roots of *Veronica virginica* L. (*Leptandra virginica*, Nuttall) but did not identify the type of linkage.

This acid, furthermore, has been noted as a complex in larger molecules, none of which are likely to arise in steam distilled oils but may be present in extracts from safflower (see Kametaka and Perkin⁵), and kava root (see Borsche and Gerhardt⁶).

The acid may also be observed in old or oxidized oils of estragon as Dautresne⁷ has found that the aldehyde occurs in this ethereal oil.

Isolation.—Hariharan and Sudborough⁸ reported that the ethyl ester m. 49°–50°, b₁₂₀ 245°–255°, sediments directly after long standing from ethereal oil of *Kaempferia galanga* L. in 30% yield. These authors obtained 2.4 to 3.2% of volatile oil from the botanical.

De Kock⁹ readily isolated the pure free acid by saponifying the ester with alcoholic potassium hydroxide, crystallizing the potassium salt, freeing the acid with sulfuric acid, and recrystallizing it from methyl alcohol.

According to Foote,¹⁰ the acid may also be isolated as ammonium salt, by passing anhydrous ammonia into its solution in toluene.

Identification.—(1) The methyl ester m. 88°–90° is readily prepared from *p*-coumaric acid methyl ether and methyl alcohol in presence of a small amount of sulfuric acid (Power and Rogerson¹¹); or through the acid chloride, according to Perkin.¹²

(2) The dibromide of the free acid melts at 149°, and that of the ethyl ester at 111°–112°, according to Hariharan and Sudborough.¹³

(3) Sondern¹⁴ readily prepared the guaiacol ester m. 102°–103°, and the α -naphthol ester m. 102°.

(4) The phenyl ester melts at 76°–77°, the β -naphthyl ester at 130°–131°, the phenacyl ester at 136°, according to Foote.¹⁵

Properties.—Several authors reported the fact that this acid displays liquid-crystalline properties, melting first to an opalescent fluid near 170°, finally to

a translucent liquid at about 185° (cf. de Kock,¹⁶ Vorländer,¹⁷ Power and Rogerson,¹⁸ and Hariharan and Sudborough¹⁹).

However, a careful study of the heating curve of the two transformations of this acid led Skau and Meier²⁰ to report the temperatures corresponding to the passage from solid to liquid crystals and from liquid crystals to liquid as 172.1° and 187.3°, respectively.

The acid moreover allows of *cis-trans*-forms. Evidently the *trans*-form is that ordinarily isolated, as de Costa²¹ has reported the lower melting *cis*-form as m. 65°.

The acid is moderately soluble in hot water and alcohol, soluble in hot acetic acid (Perkin²²).

Use.—*p*-Methoxycinnamic acid is not used in the perfume or flavor industries.

¹ *Pharm. J.* [3], **15** (1884), 362.

² *Koninklijke Akademie van Wetenschappen te Amsterdam* **3** (1901), 38. Cf. *ibid.* **4** (1902), 618. *Ber. Schimmel & Co.*, Oct. (1900), 37; April (1903), 38.

³ *J. Indian Inst. Sci.* **9A** (1926), 133.

⁴ *J. Chem. Soc.* **97** (1910), 1954.

⁵ *Ibid.*, 1415.

⁶ *Ber.* **47** (1914), 2902.

⁷ *Compt. rend.* **145** (1907), 876. *Bull. soc. chim.* [4], **3** (1908), 330, 656.

⁸ *J. Indian Inst. Sci.* **8A** (1925), 192.

⁹ *Z. physik. Chem.* **48** (1904), 132.

¹⁰ *J. Am. Pharm. Assocn.* **17** (1928), 958.

¹¹ *J. Chem. Soc.* **97** (1910), 1954. See also Ramage and Robinson, *J. Chem. Soc.* (1933), 609.

¹² *Ibid.* **39** (1881), 439.

¹³ *J. Indian Inst. Sci.* **8A** (1925), 189.

¹⁴ *J. Am. Pharm. Assocn.* **25** (1936), 418.

¹⁵ *Ibid.* **17** (1928), 958.

¹⁶ *Z. physik. Chem.* **48** (1904), 132, 165.

¹⁷ *Ibid.* **57** (1907), 359.

¹⁸ *J. Chem. Soc.* **97** (1910), 1954.

¹⁹ *J. Indian Inst. Sci.* **8A** (1925), 189.

²⁰ *Trans. Far. Soc.* **31** (1935), 478.

²¹ *Compt. rend.* **198** (1934), 1996.

²² *J. Chem. Soc.* **31** (1877), 409. *Jahresber. Fortschritte Chem.* (1877), 792.

SUGGESTED ADDITIONAL LITERATURE

P. A. Foote, "Para-Methoxy Cinnamic Acid. A Revision," *J. Am. Pharm. Assocn.* **18** (1929), 880.

C. MISCELLANEOUS ACIDS

Camphoric Acid

 $C_{10}H_{16}O_4$

Mol. Weight 200.23

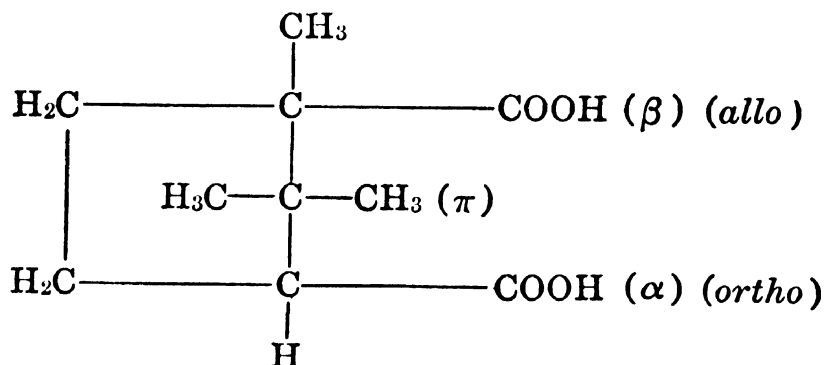

This acid has attained considerable importance in the characterization of camphor derivatives, as a product of their oxidation. Aschan¹ showed that actually there exist only six isomeric camphoric acids whose listing, configuration, and properties follow.

Careful measurements have been made by Campbell,² and later by Singh³ in connection with the determination of the specific rotation of the *d*- and *l*-camphoric acids. The findings of the latter authors are given for these isomers. The remainder of the data are quoted from Aschan.

Specific Rotation in Ethyl Alcohol at 35° C. for
Na 5892, c = g/100 cc.

Isomer	m.					
		c = 1.2533	3.2467	5.253	7.2500	9.2500
<i>d</i> -Camphoric acid	187°	+49° 52'	+48° 4'	+47° 47'	+47° 26'	+46° 57'
		c = 1.2526	3.2473	5.250	7.2507	9.2480
<i>l</i> -Camphoric acid	187°	-50° 18'	-48° 12'	-47° 48'	-47° 23'	-47° 1'
		m.			[α] _D	
<i>dl</i> -Camphoric acid	202°-203°			[α] _D	±0°	
<i>d</i> -isoCamphoric acid	171°-172°			[α] _j ²⁰	+48° 36' (c = 9.88)	(absolute alc.)
<i>l</i> -isoCamphoric acid	171°-172°			[α] _j ¹⁵	-48° 54' (c = 10.00)	
<i>dl</i> -isoCamphoric acid	191°			[α] _D	±0°	

These camphoric and isocamphoric acids are related as geometric isomers, their relative configurations being illustrated in the following formulas:

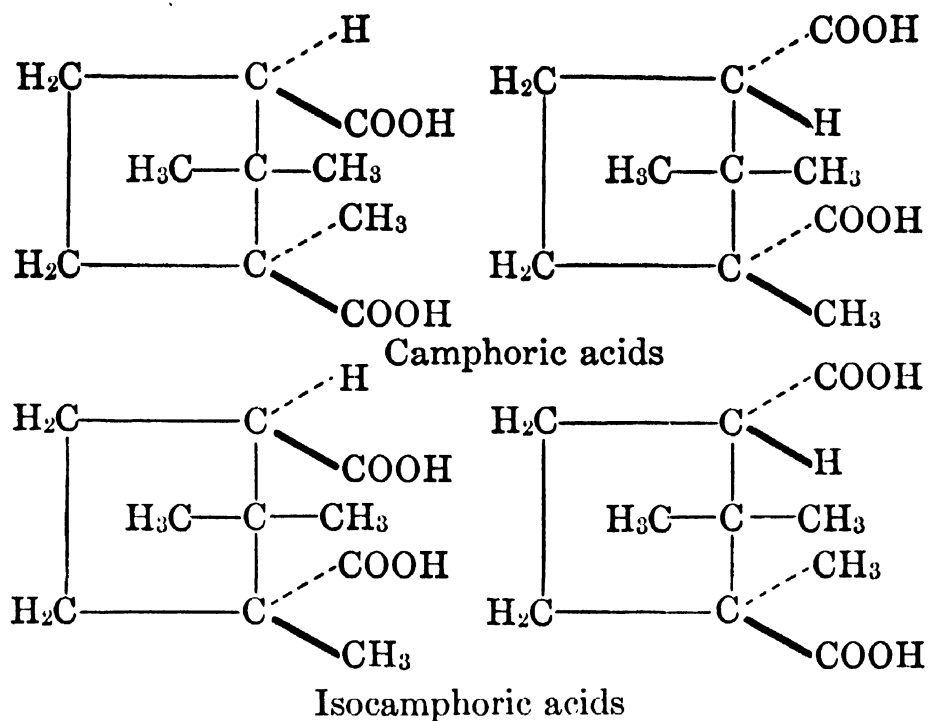

All other camphoric acids described in literature, according to Aschan, are merely mixtures. As these acids are themselves "derived" from camphors no further derivatives of the same are included at this point, although a number can be found in the literature.

¹ *Ber.* **27** (1894), 2001. *Acta Soc. Sci. Fennicae* V, **21** (1895), 47. *Liebigs Ann.* **316** (1901), 209.

² *J. Am. Chem. Soc.* **53** (1931), 1665.

³ *Current Sci.* III (1935), 420. *Proc. Ind. Acad. Sci.* **2A** (1935), 381.

SUGGESTED ADDITIONAL LITERATURE

J. Brecht, "History of the Constitution of Camphoric Acid and Its Esters," *J. prakt. Chem.* **133** (1932), 92. *Chem. Abstracts* **26** (1932), 2446.

Bawa K. Singh, Kailashpati Narayan, Parameshwar Sinha, Sheonath Prasad and Nutbehari Chatterji, "The Physical Identity of Enantiomers." Pt. III. "Viscosities, densities and refractivities of *d*- and *l*- and *dl*- forms of isonitrosocamphor (stable and unstable), camphor, camphoric acid, camphoric anhydride, camphorquinone and sodium camphorate", *Proc. Ind. Acad. Sci.* **5A** (1937), 484.

Nepetalic Acid

$C_{10}H_{16}O_3$

Mol. Weight 184.23

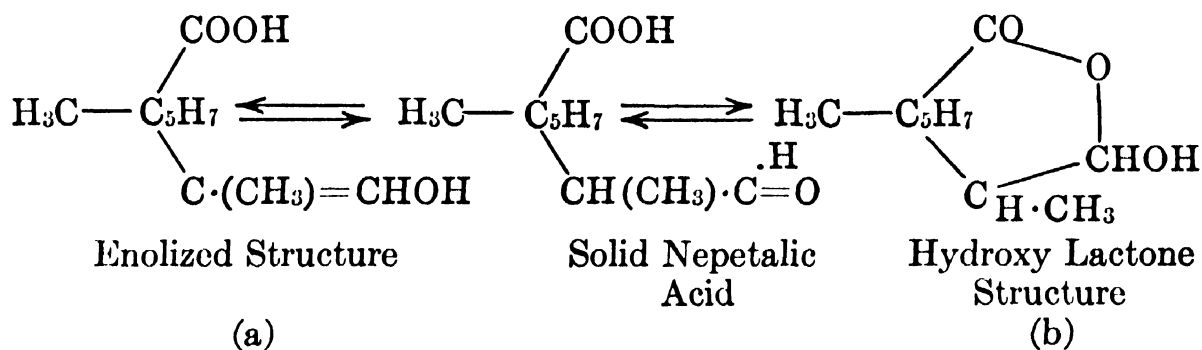

According to McElvain, Bright and Johnson,¹ nepetalic acid is a tri-substituted cyclopentane with $-CH_3$, $-COOH$, and $-CH(CH_3)C(=O)H$ as the

substituent groups. In solution this aldehydo-acid appears to exist in two tautomeric forms: (a) as enolized structure and (b) as hydroxylactone structure.

Occurrence.—Meyer ² found that nepetalic acid is one of the main constituents of catnip oil (*Nepeta cataria*). Together with nepetalactone, this acid comprises the 85 per cent of catnip oil that dissolves in aqueous sodium hydroxide.

Isolation.—(1) According to McElvain, Bright and Johnson,³ the most satisfactory method of preparing the crystalline nepetalic acid starts with the extraction of catnip oil with a saturated aqueous sodium bicarbonate solution. About 30% of the oil goes into the bicarbonate solution with a vigorous evolution of carbon dioxide. Acidification of the resulting aqueous solution precipitates the nepetalic acid as a mixture of oil and solid which crystallizes further on standing.

(2) Meyer ⁴ reported the preparation of a bisulfite addition compound of nepetalic acid. Later, McElvain, Bright and Johnson ⁵ found that this compound m. 95°–97° can be prepared in 65% yield from the acid by warming the latter on a steam bath for 10 min. with a 30% solution of sodium bisulfite. The crystalline acid may be regenerated from the bisulfite compound by treatment with 5% sulfuric acid. Since the yield of recovered acid from this operation amounted to only 60% of the theoretical, the bisulfite procedure does not offer a very satisfactory purification route.

Identification.—Nepetalic acid can be characterized through its semicarbazone, which is prepared by treating an aqueous-alcoholic solution of nepetalic acid with an aqueous solution of semicarbazide-hydrochloric acid buffered with sodium acetate. The semicarbazone melts at 160°–161°.

Properties.—Nepetalic acid is odorless. When isolated from catnip oil with sodium bicarbonate solution, as described above, nepetalic acid melts at 74°–75°, $\alpha_D^{23} +48^\circ 6'$. This is a considerably higher rotation than that obtained with nepetalic acid extracted from oil of catnip with aqueous sodium hydroxide, and suggests that this latter reagent causes some racemization of the acid.

Acetic anhydride converts nepetalic acid (in hydroxy lactone form) quantitatively into the acetate.

According to McElvain, Walters and Bright,⁶ the anhydride of nepetalic acid forms slowly at ordinary temperatures in noncrystalline samples of nepetalic acid on standing (see "Nepetalic 'Anhydride'").

Distillation at atmospheric pressure converts nepetalic acid into an unsaturated lactone, nepetalactone.

Nepetalic acid is oxidized by hydrogen peroxide in alkaline solution to formic and nepetonic acids. The latter acid contains an acetyl group in the place of the $-\text{CH}(\text{CH}_3)\cdot\text{CHO}$ substituent of nepetalic acid. Sodium hypiodite converts nepetonic acid into nepetic acid, a methyldicarboxycyclopentane. Oxidation of nepetalic acid with chromic acid converts the aldehyde group to a carboxyl and produces the dibasic nepetalinic acid.

Use.—Nepetalic acid, as such, is not used in our industries.

¹ *J. Am. Chem. Soc.* **63** (1941), 1558.

² *Pharm. Arch.* **7** (1936), 17.

³ *J. Am. Chem. Soc.* **63** (1941), 1558.

⁴ *Pharm. Arch.* **7** (1936), 17.

⁵ *J. Am. Chem. Soc.* **63** (1941), 1558.

⁶ *Ibid.* **64** (1942), 1828.

Sedanonic Acid

 $C_{12}H_{18}O_3$

Mol. Weight 210.26

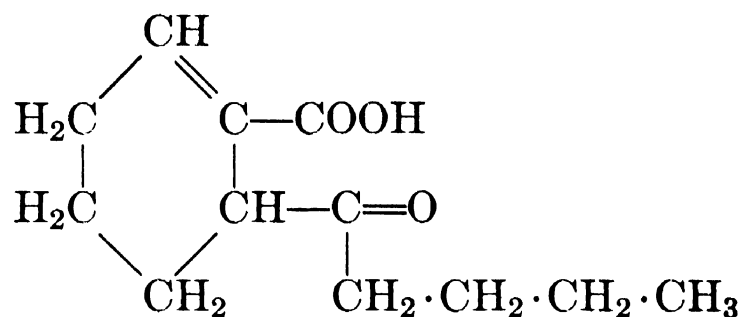

and

Sedanonic Anhydride

 $C_{12}H_{16}O_2$

Mol. Weight 192.25

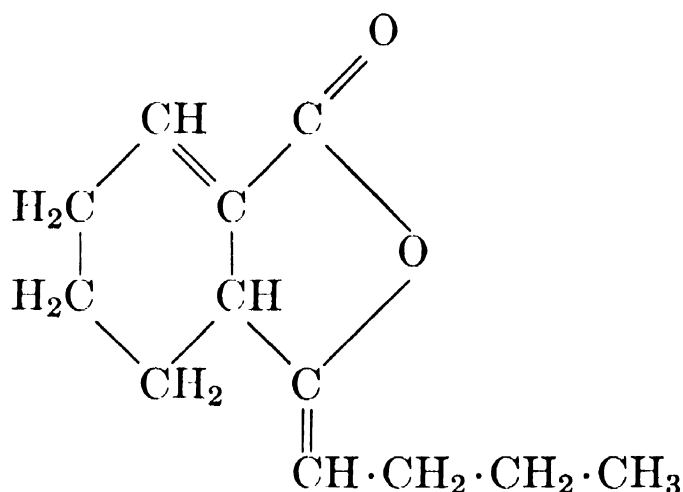
 Δ^2 -Tetrahydro-*n*-butylidene phthalide

Occurrence.—Sedanonic acid and sedanonic anhydride were first isolated from celery seed oil by Ciamician and Silber.¹ Years later, Murayama,² Murayama and Itakagi,³ Noguchi,⁴ and Noguchi and Kawanami⁵ observed sedanonic acid in the essential oil of another umbelliferous plant, viz., *Cnidium officinale* Makino, a drug called in China Hsiung-Ch'uang. More recently Naves⁶ isolated sedanonic anhydride from oil of lovage root.

A relative of sedanonic acid is valerophenone-*o*-carboxylic acid $C_{12}H_{14}O_3$

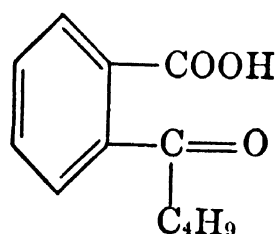

which Kariyone and Kotani⁷ showed to be identical with the "Ligusticum acid" $C_{12}H_{16}O_3$, previously isolated by Kariyone, Kanno and Sugino⁸ from the benzene extract of the fruit of *Ligusticum acutilobum* Sieb. and Zucc. (family *Umbelliferae*). "Ligusticum lactone" $C_{12}H_{14}O_2$, obtained by the action of formic acid on "Ligusticum acid," proved to be butylidene phthalide.

Isolation.—As Naves⁹ pointed out, all methods aiming at the separation of these acids are beset with one difficulty—the yield of lactones. Nevertheless it is possible to isolate sedanonic acid and even valerophenone-*o*-carboxylic acid if one conducts a current of carbon dioxide through their salt solutions during these operations.

Identification.—Naves¹⁰ thus isolated and identified sedanonic anhydride from the tail fractions (1.3 g.) of lovage root oil, after saponification with a 25% potassium hydroxide solution, and by treatment of the acids with hydrazine hydrate (2 cc.) on a water bath. When recrystallizing from alcohol, the crystals (0.27 g.) of tetrahydro-*n*-butyl phthalazone melted at 136°.

Heating sedanonic acid with paladium charcoal at 330° to 340° for 3 hr., Noguchi and Kawanami¹¹ obtained butyl phthalide which, on nitration, yielded 6-nitrobutyl phthalide m. 53°–54°.

Ciamician and Silber,¹² as well as Murayama and Itagaki,¹³ prepared the oxime of sedanonic acid, m. 128°.

According to Noguchi and Kawanami,¹⁴ valerophenone-*o*-carboxylic acid forms an amide m. 134°, and a semicarbazone m. 180°.

Properties.—Murayama and Itagaki,¹⁵ and Ciamician and Silber¹⁶ reported the melting point of sedanonic acid as 113°.

According to Noguchi and Kawanami,¹⁷ valerophenone-*o*-carboxylic acid boils at b₂ 168°–175°.

Use.—Sedanonic acid, as such, is not used in our industries.

¹ *Ber.* **30** (1897), 492, 501, 1419, 1424, 1427.

² *J. Pharm. Soc. Japan* **477** (1921), 951. *Chem. Zentr.* I (1922), 416.

³ *J. Pharm. Soc. Japan* **493** (1923), 15. *Chem. Zentr.* III (1923), 252.

⁴ *J. Pharm. Soc. Japan* **54** (1934), 171. *Chem. Zentr.* I (1935), 1069.

⁵ *J. Pharm. Soc. Japan* **57** (1937), 191. *Chem. Zentr.* II (1937), 4050.

⁶ *Helv. Chim. Acta* **26** (1943), 1281.

⁷ *J. Pharm. Soc. Japan* **57** (1937), 183. *Chem. Zentr.* II (1937), 4051.

⁸ *J. Pharm. Soc. Japan* **56** (1936), 113. *Chem. Zentr.* I (1937), 1456.

⁹ *Helv. Chim. Acta* **26** (1943), 1282.

¹⁰ *Ibid.*, 1293.

¹¹ *J. Pharm. Soc. Japan* **57** (1937), 191. *Chem. Zentr.* II (1937), 4050.

¹² *Ber.* **30** (1897), 501.

¹³ *J. Pharm. Soc. Japan* **493** (1923), 143.

¹⁴ *J. Pharm. Soc. Japan* **57** (1937), 191. *Chem. Zentr.* II (1937), 4050.

¹⁵ *J. Pharm. Soc. Japan* **493** (1923), 143.

¹⁶ *Ber.* **30** (1897), 500.

¹⁷ *J. Pharm. Soc. Japan* **57** (1937), 196. *Chem. Zentr.* II (1937), 4050.

The Santalic Acids



Mol. Weight 234.33

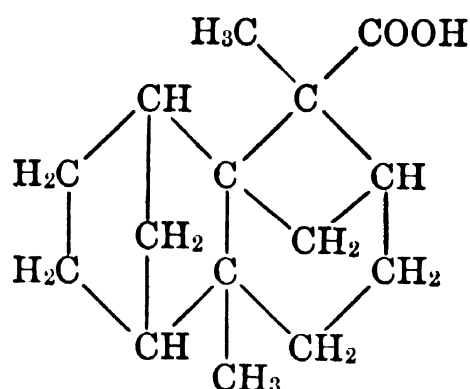

Guerbet's Acid or γ -Santalic Acid
(According to Guha and Bhattacharyya)

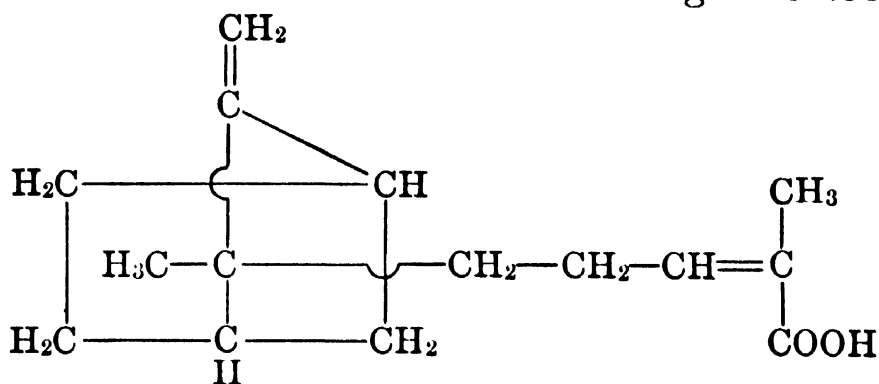

β -Santalic Acid
(According to Bhattacharyya)

Occurrence.—Guha and Bhattacharyya¹ identified in East Indian sandalwood oil a new monobasic terpenic acid of bicyclic structure which they named β -santalic acid.

Guha and Bhattacharyya² isolated Guerbet's³ "santalic acid" from sandalwood oil. However, these workers described their isolate as " γ -santalic acid" as they have shown that it bears no structural relationship to α -santalol, nor is it identical with α -santalic acid.

γ -Santalic acid is reported as a saturated tetracyclic sesquiterpene derivative.

Isolation.—Boil sandalwood oil for one-half hour with the required amount of 3% alcoholic potash to saponify the esters. Distill off the excess of alcohol, pour the residual oil into water and separate the oily layer. Extract the oil layer repeatedly with water, evaporate the combined aqueous liquors to a smaller bulk, and extract the residuum with ether. Acidify the alkaline aqueous liquor with cold dilute sulfuric acid and take up the oily acid layer with ether. Dry the extract and fractionate. The fraction b_1 150°–172° is mostly Guerbet's acid, whereas the fraction b_1 172°–188° is primarily β -santalic acid. Repeated fractionation of the fraction rich in γ -santalic acid yields the nearly pure γ - product.

Identification and Properties.— γ -Santalic acid or Guerbet's acid has been characterized by Guha and Bhattacharyya as follows:

b_9	189°	$n_D^{28.5}$	1.5021
b_1	166°	n_D^{20}	1.5055

γ -Santalic acid is a syrupy liquid with a persistent odor, and is insoluble in water. The silver salt is stable toward light. This acid cannot be titrated with alkali.

The methyl ester has these properties:

b_9	141°	n_D^{25}	1.4892
d_4^{25}	1.02483	n_D^{20}	1.4915
d_4^{20}	1.02858		

This acid is shown by comparative evaluation with percamphoric acid and by means of spectroscopic evidence to contain a small amount of β -santallic acid.

β -Santallic acid, according to Bhattacharyya, in all probability is the corresponding carboxylic acid of β -santalol. This author describes the new β -santallic acid as follows:

b_9	202°	$n_{D_1}^{28.5}$	1.5100
b_1	181°	n_D^{20}	1.5136

The methyl ester of β -santallic acid has these properties:

b_9	157°
n_D^{20}	1.4989

This weak acid is likewise of thick and syrupy consistency and water insoluble, with an odor like that of Guerbet's acid.

Use.—Santallic acid is not used in our industries.

¹ *J. Indian Chem. Soc.* **21** (1944), 333, 337.

² *Ibid.*, 336.

³ *Compt. rend.* **130** (1900), 417.

D. ACIDS OF DOUBTFUL CONSTITUTION

Costus Acid

(Costusic Acid)

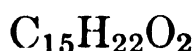

Mol. Weight 234.33

This bicyclic acid containing two double bonds was found by Semmler and Feldstein ¹ in the fraction b_{11} 190°–200° (d_{21} 1.0501, α_D +44°, n_D 1.52703) of costus root oil (*Saussurea lappa* Clarke).

When purified through its silver salt, costus acid had these properties:

b_{11}	200°–205°	Mol. refr.	Calc. 67.85
d_{21}	1.0508		Found 67.73
α_D	+40° 0'	Methyl ester	b_{11} 170°–175°
n_D	1.51912		

On reduction with sodium and alcohol, the methyl ester of costus acid yields costol (see "Costol"), a bicyclic, primary sesquiterpene alcohol $C_{15}H_{24}O$ containing two double bonds.

When warmed with 33 per cent sulfuric acid, costus acid is transformed into dihydrocostus lactone (see "Dihydrocostus Lactone").

¹ *Ber.* **47** (1914), 2433, 2687.

E. ANHYDRIDES

Nepetalic "Anhydride"

 $C_{20}H_{30}O_5$

Mol. Weight 350.44

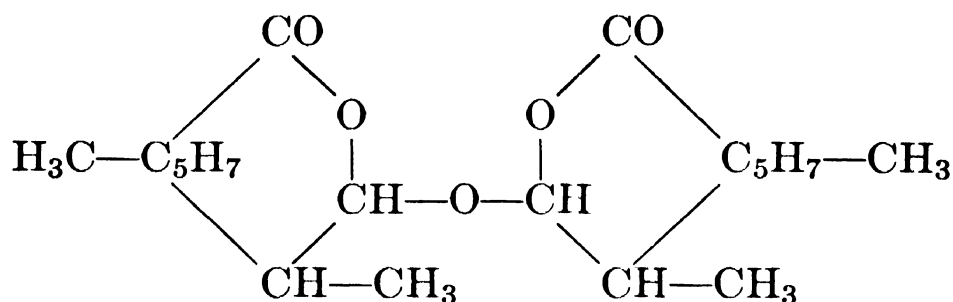

According to McElvain, Walters and Bright,¹ nepetalic "anhydride" is the anhydride of the hydroxy lactone form of nepetalic acid (see "Nepetalic Acid"). $\text{>C}_5\text{H}_7\text{—CH}_3$ is a methylocyclopentane nucleus. Nepetalic "anhydride" slowly forms when noncrystalline nepetalic acid is kept standing at ordinary temperatures.

Occurrence.—McElvain et al.² found that nepetalic "anhydride" comprises about 36 per cent of the alkali-insoluble portion (10 per cent) of the volatile oil derived from catnip (*Nepeta cataria*).

Isolation.—The residue remaining from the initial crude fractionation of the neutral portions of catnip oil is distilled and yields a yellow viscous oil $b_{0.1}$ $200^\circ\text{--}210^\circ$, from which on standing nepetalic "anhydride" crystallizes.

Identification.—Hydrolysis with dilute hydrochloric acid converts nepetalic "anhydride" into nepetalic acid m. $74^\circ\text{--}75^\circ$ which can be characterized by the preparation of its semicarbazone m. $160^\circ\text{--}161^\circ$ (see "Nepetalic Acid").

Properties.—Nepetalic "anhydride" is an odorless crystalline mass. After recrystallization from petroleum ether it melts at $139^\circ\text{--}140^\circ$, $[\alpha]_D^{25} +136^\circ$ (in chloroform).

Use.—Nepetalic "anhydride," as such, is not used in our industries.

¹ *J. Am. Chem. Soc.* **64** (1942), 1828.

² *Ibid.*

VIII. ESTERS

Introduction.—Esters are widely distributed in essential oils, being among their most important constituents and contributing greatly to the character of their odor and flavor. In fact, some essential oils consist almost entirely of esters; oil of wintergreen and oil of sweet birch, for example, contain up to 99 per cent of methyl salicylate.

A few esters solidify at room temperature and can thus be readily separated from an oil by cooling, but in most cases the isolation and identification of esters are accompanied by some difficulty. First of all, direct crystalline derivatives of esters, which would permit their characterization, are not nearly so numerous as those of alcohols, aldehydes, ketones, most terpenes and sesquiterpenes. Therefore, one has to resort to fractional distillation and to the preparation of crystalline derivatives of the saponification products. Secondly, many esters decompose on distillation, especially at atmospheric pressure. The application of a good vacuum is, therefore, of paramount importance. Moreover, prior to fractionation the oil must be freed from organic acids in order to prevent hydrolysis of the esters during distillation. Thirdly, the boiling points of some esters are so close that such esters cannot be completely separated by mere fractionation. For all these reasons the isolation of esters from essential oils and their identification present a delicate problem requiring great care.

In recent literature several techniques have been suggested, which permit identification of fractional groups in esters without previous saponification. These methods include ammonolysis as well as aminolysis of the esters. The acid radical is thereby identified by means of the derived amide. (See p. 831.)

SUGGESTED ADDITIONAL LITERATURE

C. F. Koelsch and David Tenenbaum, "A Method for the Identification of the Acyl Group in Certain Esters," *J. Am. Chem. Soc.* **55** (1933), 3049.

F. Feigl, V. Anger and O. Frehden, "Detection of Carboxylic Acids and Their Derivatives (Anhydrides, Esters and Halides)," *Mikrochemie* **15** (1934), 9.

Douglas V. N. Hardy, "Identification of Acids and Esters," *J. Chem. Soc.* (1936), 398.

C. A. Buehler and Charles A. Mackenzie, "The Action of Benzylamine on Aliphatic Esters," *J. Am. Chem. Soc.* **59** (1937), 421.

O. C. Dermer and Jack King, "N-Benzylamides as Derivatives for Identifying the Acyl Groups in Esters," *J. Org. Chem.* **8** (1943), 168.

R. W. Moncrieff, "Esters in Perfumery," *Soap, Perfumery and Cosmetics* **20** (1947), 654.

Kurt Kulka, "Ester Preparation," *Am. Perfumer* **50** (1947), 545.

A. ALIPHATIC ESTERS

Ethyl Acetate



Mol. Weight 88.10

"Acetic ether"

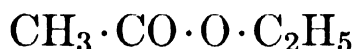

Occurrence.—The occurrence of ethyl acetate in essential oils is probable but has not been definitely proved. However, ethyl acetate is a constituent of natural fruit flavors—for example, of the volatile esters derived from pineapple.

Isolation.—By fractional distillation. When it is desired to purify the ester from small amounts of impurities, such as water, ethyl alcohol, and acetic acid, the methods recommended by Gillo¹ may be employed.

Identification.—Saponify the ester and identify the components as ethyl alcohol and acetic acid.

Properties.—Ethyl acetate is an optically inactive, mobile, quite volatile liquid, possessing a strong, refreshing, very fruity odor and flavor.

According to Timmermans and Hennaut-Roland,² Wojciechowski and Smith,³ von Rechenberg,⁴ Young,⁵ Rozhdestvenskii, Pukirev and Longinov,⁶ Gillo,⁷ Krehma and Williams,⁸ Allsopp and Willis,⁹ and Gildemeister and Hoffmann,¹⁰ ethyl acetate has properties as tabulated below.

Von Rechenberg published extensive boiling point data, while Young presented a considerable amount of material on specific gravity determinations. Allsopp and Willis reported the results of their investigations for refractivity of the ester over a wide range of wave lengths. However, only a limited number of data from these authors are included here:

m.	-83.6° ²	b_{50}	12.78° ⁴
	-83.4° ⁴	b_{20}	-3.08° ⁴
b_{800}	78.66° ⁴	b_{10}	-13.25° ⁴
b.	77.15° ^{2, 4, 5, 6, 7}	d_4^{80}	0.8245 ⁵
	77.11° ³	d_4^{70}	0.8376 ⁵
b_{600}	70.18° ⁴	d_4^{60}	0.8508 ⁵
b_{400}	58.71° ⁴	d_4^{50}	0.8636 ⁵
b_{200}	41.31° ⁴	d_4^{40}	0.8762 ⁵
b_{100}	26.13° ⁴	d_4^{30}	0.8885 ⁵

d_4^{25}	0.89453 ²	d_4^{15}	0.90657 ²
	0.8946 ³	d_4^{10}	0.9127 ⁵
d_4^{20}	0.9005 ^{5,9}	d_4^0	0.92451 ⁷
		n_D^{25}	1.3695 ⁸
		n_D^{20}	1.37229 ⁹
		n_D^{11}	1.3732 ²

Sol. Miscible with most organic solvents.
Ethyl acetate itself is a good solvent.
Soluble in 18 vol. of water; vice versa
28 vol. of ethyl acetate dissolve 1 vol.
of water ¹⁰

Use.—Ethyl acetate is used widely in all kinds of flavors for confectionery, beverages, etc.

¹ *Bull. soc. chim. Belg.* **48** (1939), 341, 412.

² *J. chim. phys.* **27** (1930), 429.

³ *J. Res. Natl. Bur. Stand.* **18** (1937), 503.

⁴ Schimmel & Co., "Einfache und fraktionierte Destillation in Theorie und Praxis," Leipzig (1923), 238, 335.

⁵ *Proc. Sci. Roy. Dublin Soc.* **12** (1910), 387, 434.

⁶ *Trans. Inst. Pure Chem. Reagents U.S.S.R., Sci.-Tech. Dept. No. 300* (1929). *Chem. Abstracts* **24** (1930), 3755.

⁷ *Bull. soc. chim. Belg.* **48** (1939), 341, 412.

⁸ *J. Am. Chem. Soc.* **49** (1927), 2411.

⁹ *Proc. Roy. Soc. London A* **153** (1936), 401, 402.

¹⁰ "Die Ätherischen Öle," 3d Ed., Vol. I, 637.

SUGGESTED ADDITIONAL LITERATURE

H. Lowery, H. C. Poole and C. Isherwood, "Refraction of Gaseous Acetaldehyde and Ethyl Acetate," *Phil. Mag.* [7] **14** (1932), 743. *Chem. Abstracts* **27** (1933), 3649.

F. Feigl, V. Anger and O. Frehden, "Detection of Carboxylic Acids and Their Derivatives (Anhydrides, Esters and Halides)," *Mikrochemie* **15** (1934), 9.

G. S. Shaw, "Methods of Analysis for Acetylene, Acetic Acid Anhydride, Ethyl Acetate and Mercury," *Can. Chem. Proc. Ind.* **25** (1941), 197.

G. V. L. N. Murty and T. R. Seshadri, "Raman Effect and Hydrogen Bonds. Mixtures of Esters and Acceptor Molecules," *Proc. Indian Acad. Sci.* **14A** (1941), 593. *Chem. Abstracts* **36** (1942), 4026.

C. L. Lindeken, J. O. Clayton and D. A. Skoog, "Determination of Ethyl Acetate in the Presence of Acetaldehyde," *Ind. Eng. Chem., Anal. Ed.* **16** (1944), 734.

B. TERPENE ESTERS

Linalyl Acetate

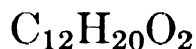

Mol. Weight 196.28

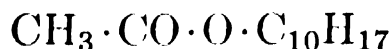

(See "Linaloöl")

Occurrence.—This important ester is the principal constituent of lavender and bergamot oil; in fact, these oils are evaluated mainly by their content of linalyl acetate. The ester is present also in numerous other essential oils—for example, petitgrain, clary sage, neroli bigarade, ylang ylang, jasmine flower oil, etc.

Isolation.—By fractional distillation *in vacuo*.

Identification.—Saponify the ester and identify the components as linaloöl and acetic acid.

Properties.—Linalyl acetate is a colorless oil, possessing a pleasant, fruity odor, reminiscent of bergamot oil. The optical rotation (*d*- or *l*- rotatory) of the synthetic product depends upon the linaloöl used for the preparation of the ester. Although both *d*- and *l*-linalyl acetate have also been reported as natural isolates, there evidently exists some question regarding the purity of certain of these products.

Hesse and Zeitschel,¹ Barillet and Berthelé,² Penfold and Grant,³ Kaufmann and Kjelsberg,⁴ Gildemeister and Hoffmann,⁵ and Likhtman⁶ reported these properties for linalyl acetate:

b ₇₆₂	220° ¹ (decomposition)	$[\alpha]_D^{20}$	−7° 42' to −8° 18' ⁴
b ₂₅	115°–116° ¹	n_D^{21}	1.4544 ²
b ₁₁	105°–106° ²	n_D^{20}	1.450 ⁴
b ₁₀	98°–100° ³	Sol.	Soluble in 3–5 vol. of
d ₄ ²⁰	0.8998 ⁶		70% alcohol ⁵
d ₁₅	0.9060 ^{2,4}		

On distillation with steam, or at atmospheric pressure, linalyl acetate is readily hydrolyzed and decomposed, respectively.

Use.—Linalyl acetate is widely used in the perfume, cosmetic, and soap industries. Useful in Eau de Cologne and in lavender compositions, and for the compounding of artificial essential oils. Linalyl acetate imparts a refreshing top note to floral and to oriental perfumes. It is valuable also in artificial flavors.

¹ *J. prakt. Chem.* [2], **64** (1901), 256.

³ *J. Proc. Roy. Soc. N. S. Wales* **58** (1924), 120.

² *Bull. soc. chim.* [4], **17** (1915), 21.

⁴ *Am. Perfumer* **22** (1927), 500.

⁵ "Die Ätherischen Öle," 3d Ed., Vol. J, 641.

⁶ *Org. Chem. Ind. U.S.S.R.* **4** (1937), 629. *Chem. Abstracts* **32** (1938), 6227.

Geranyl Formate

 $C_{11}H_{18}O_2$

Mol. Weight 182.25

 $H \cdot CO \cdot O \cdot C_{10}H_{17}$

(See "Geraniol")

Occurrence.—Geranyl formate occurs very probably in geranium oil.

Isolation.—By fractional distillation *in vacuo*.

Identification.—Saponify the ester and identify the components as formic acid and geraniol, whose characterization is described elsewhere in this work.

Properties.—Geranyl formate is a colorless oil possessing a rose-like but somewhat "dry" odor. According to Tiemann and Schmidt,¹ Bertram,² Gildemeister and Hoffmann,³ Tromp,⁴ and Lewinsohn,⁵ geranyl formate has these properties:

b_{15}	$113^{\circ}-114^{\circ}$ ¹	n_D^{20}	1.461–1.465 ³
b_{10-11}	$104^{\circ}-105^{\circ}$ ²	$n_D^{19.93}$	1.46592 ⁴
b_3	88° ⁵	Sol.	Soluble in 10 vol. of 70% alcohol and more ³
d_4^{25}	0.90859 ⁴		
$d_4^{15.2}$	0.91641 ⁴		

Like all formates, geranyl formate readily decomposes, especially on distillation at atmospheric pressure.

Use.—Geranyl formate is used as an odor modifier in rose, geranium, and neroli compositions.

¹ *Ber.* **29** (1896), 907.

² German Patent No. 80,711.

³ "Die Ätherischen Öle," 3d Ed., Vol. I, 641.

⁴ *Rec. trav. chim.* **41** (1922), 285, 297.

⁵ *Perfumery Essential Oil Record* **14** (1923), 292.

Geranyl Acetate

 $C_{12}H_{20}O_2$

Mol. Weight 196.28

 $CH_3 \cdot CO \cdot O \cdot C_{10}H_{17}$

(See "Geraniol")

Occurrence.—This important ester is widely distributed in essential oils, forming in some oils a principal constituent. It occurs, for example, in oil of citronella, palmarosa, lemongrass, geranium, petitgrain, neroli bigarade, lavender, coriander, *Eucalyptus macarthuri* and *E. staigeriana*, etc.

Isolation.—By fractional distillation *in vacuo*.

Identification.—Saponify the ester and identify the components as geraniol and acetic acid. The identification of these products is described elsewhere in this work.

Properties.—Geranyl acetate is a colorless liquid, possessing a pleasant fruity odor reminiscent of rose.

Barbier,¹ Bertram and Gildemeister,² Jeancard and Satie,³ Reyhler,⁴ Müller,⁵ Tromp,⁶ Gildemeister and Hoffmann,⁷ O'Donoghue, Drum and Ryan,⁸ and Isagulyants and Serebrennikov⁹ reported the following properties for geranyl acetate:

b ₇₆₂	242°–245° ² (decomposition)	d ₄ ²⁵	0.9080 ⁶
b ₂₂	130°–132° ⁴	d ₄ ¹⁵	0.9163 ⁶
b ₁₅	127°–129° ⁸	d ₁₁	0.9230 ³
b ₁₄	127.8° ⁵	d ₀	0.9388 ¹
b ₇	114°–115° ⁹	n _D ²⁰	1.4655 ⁹
			1.4624 ⁶
		n _D ¹⁵	1.4628 ²

Sol. Soluble in 5–10 vol. of 70% alcohol⁷

Isagulyants and Serebrennikov¹⁰ reported the isomerization of geranyl acetate to cyclogeranyl acetate.

Use.—Geranyl acetate is very widely used in the perfume, cosmetic, and soap industry. It forms a main ingredient in the compounding of rose scents and has its place in almost any perfume composition. It is valuable also in artificial flavors.

¹ *Compt. rend.* **117** (1893), 122.

² *J. prakt. Chem.* **49** (1894), 189.

³ *Bull. soc. chim.* [3], **25** (1901), 521.

⁴ *Bull. soc. chim. Belg.* **21** (1907), 430.

⁵ *Ber.* **54** (1921), 1471.

⁶ *Rec. trav. chim.* **41** (1922), 285, 297.

⁷ "Die Ätherischen Öle," 3d Ed., Vol. I, 642.

⁸ *Sci. Proc. Roy. Dublin Soc.* [NS] **19** (1928), 120.

⁹ *J. Gen. Chem. U.S.S.R.* **9** (1939), 917. *Chem. Abstracts* **34** (1940), 370.

¹⁰ *Ibid.*

SUGGESTED ADDITIONAL LITERATURE

V. N. Guha Roy and M. N. Goswami, "Geraniol and Geraniol Esters," *Indian Soap J.*, April to June (1945).

Neryl Acetate

C₁₂H₂₀O₂

Mol. Weight 196.28

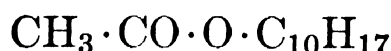

(See "Nerol")

Occurrence.—Neryl acetate occurs in several essential oils—for example, in oil of *Helichrysum angustifolium*, neroli bigarade, petitgrain, and lemon.

Isolation.—By fractional distillation *in vacuo*.

Identification.—Saponify the ester and identify the components as nerol and acetic acid. The identification of these products is described elsewhere in this work.

Properties.—Neryl acetate is a colorless liquid with a pleasant odor reminiscent of rose.

Von Soden and Treff,¹ and Reclaire² reported the following properties:

b_{25}	134° ¹	n_D^{20}	1.4510–1.4540 ²
b_3	93° – 94° ¹	Sol.	Soluble in 5–6 vol. of 70% alcohol ²
d_{15}^{15}	0.903–0.906 ²		
d_{15}	0.916 ¹		

Use.—Neryl acetate (usually the synthetic product) is used as an adjunct in the compounding of floral, particularly rose, bouquets, and in imitation lemon oils.

¹ *Ber.* **36** (1906), 910.

² *Deut. Parfümerieztg.* **15** (1929), 71.

Citronellyl Formate

$C_{11}H_{20}O_2$

Mol. Weight 184.27

$H \cdot CO \cdot O \cdot C_{10}H_{19}$

(See "Citronellol")

Occurrence.—This ester occurs, perhaps, in geranium oil.

Isolation.—By fractional distillation *in vacuo*.

Identification.—Saponify the ester and identify the components as formic acid and as citronellol whose characterization is described elsewhere in this work.

Properties.—Citronellyl formate is a colorless oil, possessing a strong fruity, somewhat "dry" odor, reminiscent of roses.

Gildemeister and Hoffmann,¹ and Tromp² (*d*-citronellyl formate) reported these properties for synthetic products:

b_{11}	97° – 98° ²	α_D	$-1^{\circ} 9'$ ¹
d_4^{25}	0.88416 ²	n_D^{20}	1.45111 ¹
d_{15}^{15}	0.9105 ¹	$n_D^{19.98}$	1.45557 ²
d_4^{15}	0.89184 ²	Sol.	Soluble in 12.5 vol. of 70% alcohol; in 2.5 vol. of 80% alcohol ¹

Citronellyl formate is not very stable; it decomposes readily on distilling at atmospheric pressure.

Use.—The ester finds only occasional use—for example, as an odor modifier in rose compositions.

¹ "Die Ätherischen Öle," 3d Ed., Vol. I, 642.

² *Rec. trav. chim.* **41** (1922), 285, 297.

Citronellyl Acetate

 $C_{12}H_{22}O_2$

Mol. Weight 198.30

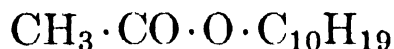

Occurrence.—This ester occurs in oils of citronella and geranium.

Isolation.—By fractional distillation *in vacuo*.

Identification.—Saponify the ester and identify the components as citronellol and acetic acid.

Properties.—Citronellyl acetate is a colorless liquid with a strong rose odor, but fruity and dry.

The following properties have been reported by Flatau and Labbé,¹ Tiemann and Schmidt,² O'Donaghue, Drum and Ryan,³ Müller,⁴ Tromp,⁵ and Gildemeister and Hoffmann:⁶

b_{34}	$172^\circ-173^\circ$ ¹	α_D	$-1^\circ 15'$ to $+2^\circ 18'$ ⁶
b_{15}	$119^\circ-121^\circ$ ^{2,3}	$[\alpha]_D^{17.5}$	$+2^\circ 22'$ ² (from <i>d</i> -citronellol)
b_{14}	117.3° ⁴ (from <i>d</i> -citronellol)	n_D^{20}	1.44287–1.44891 ⁶
b_{11}	$107^\circ-108^\circ$ ⁵	$n_D^{18.5}$	1.457 ³
d_4^{25}	0.89492 ⁵	$n_D^{17.5}$	1.4456 ² (from <i>d</i> -citronellol)
$d_{19.5}$	0.9035 ³		
$d_{17.5}$	0.8928 ² (from <i>d</i> -citronellol)	Sol.	Soluble in 6 vol. of 70% alcohol ⁶
$d_4^{15.2}$	0.90273 ⁵		
d_{15}^{15}	0.895–0.901 ⁶		

Müller⁷ reported that citronellyl acetate, on treatment with phosphoric acid in the cold, yields the acetate of 1,1,3-trimethyl-2-hydroxymethylcyclohexane.

Caldwell and Piontkowski⁸ investigated the iodine and thiocyanogen numbers of citronellyl acetate.

Sabetay⁹ observed a positive color reaction of citronellyl acetate with Bezssonoff's reagent $[MoO_3 \cdot WO_3 \cdot (P_2O_5)_{17}] \cdot 24H_2O$.

Use.—Citronellyl acetate is used widely, but sparingly, in all kinds of compositions, especially in rose scents, to which it imparts a pleasant, fruity note.

¹ *Compt. rend.* **126** (1898), 1727.

² *Ber.* **29** (1896), 907.

³ *Sci. Proc. Roy. Dublin Soc.* (N.S.) **19** (1928), 120. Beilstein, 4th Ed., 2d Ergänzungswerk, Vol. 2 (1942), 152.

⁴ *Ber.* **54** (1921), 1471.

⁵ *Rec. trav. chim.* **41** (1922), 285.

⁶ "Die Ätherischen Öle," 3d Ed., Vol. I (1928), 643.

⁷ *Ber.* **54** (1921), 1471.

⁸ *J. Am. Chem. Soc.* **56** (1934), 2088.

⁹ *Riechstoff Ind.* **13** (1938), 84.

Citronellyl Butyrate

 $C_{14}H_{26}O_2$

Mol. Weight 226.35

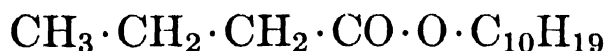

Occurrence.—This ester occurs in oil of citronella.

Isolation.—By fractional distillation *in vacuo*.

Identification.—Saponify the ester and identify the components as citronellol and butyric acid.

Properties.—Citronellyl butyrate possesses a strong rose odor, but very fruity, slightly fatty, and, as such, not too pleasant.

The following properties have been reported by Burger,¹ Kjelsberg and Müller,² and Reclaire:³

b_{13}	135°–139° ³	α_D	+0° 48' to +1° 6' ³
b_{12}	134°–135° ¹	n_D^{20}	1.4458–1.4489 ³
d_{20}	0.884 ¹	Sol.	Soluble in 6 to 9 vol. of
d_{15}	0.8874 ²		80% alcohol ³
	0.8898–0.8928 ³		

Kjelsberg and Müller⁴ reported on the velocity of saponification with half normal potassium hydroxide.

Use.—Citronellyl butyrate is used like citronellyl acetate, but even more sparingly because of its somewhat fatty note.

¹ *Riechstoff Ind.* **3** (1928), 17. Beilstein, 4th Ed., 2d Ergänzungswerk, Vol. 2 (1942), 248.

² *Deut. Parfümerieztg.* **14** (1928), 235. Beilstein, 4th Ed., 2d Ergänzungswerk, Vol. 2 (1942), 248.

³ *Riechstoff Ind.* (1926), 229. *Chimie & industrie* **19** (1928), 109. *Chem. Abstracts* **22** (1928), 1346.

⁴ *Deut. Parfümerieztg.* **14** (1928), 235. Beilstein, 4th Ed., 2d Ergänzungswerk, Vol. 2 (1942), 248.

Terpinyl Formate

 $C_{11}H_{18}O_2$

Mol. Weight 182.25

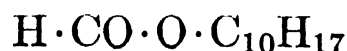

(See “ α -Terpineol”)

Occurrence.—The presence of this ester in volatile oils has not been definitely established. It possibly occurs in Ceylon cardamom oil.

Isolation.—By fractional distillation *in vacuo*.

Identification.—Saponify the ester and identify the components as terpineol and formic acid.

Properties.—Terpinyl formate is an oil of strong, pleasant odor. Gilde-meister and Hoffmann,¹ and Lafont² reported these properties for the syn-thetic product:

b ₄₀	133°–136° ² (from <i>d</i> - α -terpineol)	[α] _D	+16° 33' ² (from <i>d</i> - α -terpineol)
	135°–138° ² (from <i>l</i> - α -terpineol)		–69° 25' ² (from <i>l</i> - α -terpineol)
b ₇	95°–99° ¹		(The optical rotation of the synthetic ester depends upon that of the α -terpineol employed)
d ₁₅ ¹⁵	0.9855 ¹		
d ₀	0.9989 ² (from <i>d</i> - α -terpineol)	Sol.	Soluble in 6 vol. and more of 70% alcohol ¹
	0.9986 ² (from <i>l</i> - α -terpineol)		

Like most formates, terpinyl formate readily decomposes on distillation at atmospheric pressure.

Use.—Terpinyl formate is used on a very small scale as an odor modifier in some perfume compositions.

¹ "Die Ätherischen Öle," 3d Ed., Vol. I, 646.

² *Bull. soc. chim.* [2], **49** (1888), 325. *Ann. chim. phys.* [6], **15** (1888), 185.

Terpinyl Acetate

C₁₂H₂₀O₂

Mol. Weight 196.28



(See " α -Terpineol")

Occurrence.—This ester occurs in oil of cajuput, cypress, Malabar carda-mom oil, possibly also in niaouli, Siberian pine needle and a few other oils.

Isolation.—By fractional distillation *in vacuo*.

Identification.—Saponify the ester and identify the components as α -terpineol and acetic acid.

Properties.— α -Terpinyl acetate is a colorless oil possessing a strong odor which somewhat resembles bergamot and lavender oil. According to its origin, α -terpinyl acetate is either dextro- or laevorotatory, or optically inactive. The following properties have been reported by Bouchardat and Lafont,¹ Lafont,² Barillet and Berthel ,³ Gildemeister and Hoffmann,⁴ and Paillard and Tempia:⁵

<i>dl</i> - α -Terpinyl Acetate		<i>d</i> - α -Terpinyl Acetate	
b.	220° ⁵	b ₄₀	140° ²
b ₁₅	102°–103° ^{3,5}	[α] _D	+52° 30' ²
b ₅	90°–94° ⁴	Sol.	Soluble in 4–5 vol. of 70% alcohol ⁴
d ₁₀₀	0.8896 ¹		
d ₁₈	0.957 ¹		
d ₁₅	0.9704 ³		
d ₀	0.9753 ²		
n _D ²¹	1.4689 ³		

Terpinyl acetate is not as readily saponified as, for example, geranyl acetate or linalyl acetate. (For quantitative determination see Vol. I, Chapter 4, pp. 267 and 336.)

Use.—Terpinyl acetate is used as a general modifier in perfume compounds of the lavender and Eau de Cologne type. Because of its strong odor and low price terpinyl acetate serves widely also in the scenting of soaps and all kinds of technical preparations.

¹ *Ann. chim. phys.* [6], **9** (1886), 515.

² *Ibid.* [6], **15** (1888), 153, 211.

³ *Bull. soc. chim.* [4], **17** (1915), 21.

⁴ "Die Ätherischen Öle," 3d Ed., Vol. I, 647.

⁵ *Helv. Chim. Acta* **14** (1931), 1314.

SUGGESTED ADDITIONAL LITERATURE

H. M. Perry and T. F. West, "Determination of Terpinyl Acetate and Other Esters," *Analyst* **67** (1942), 159.

"Specifications and Standards" of the Essential Oil Association of the United States, January 10, 1947.

Bornyl Formate



Mol. Weight 182.25

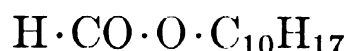

(See "Borneol")

Occurrence.—Bornyl formate has been identified in valerian root oil.

Isolation.—By fractional distillation *in vacuo*.

Identification.—Saponify the ester and identify the components as formic acid and as borneol whose characterization is described elsewhere in this work.

Properties.—Bornyl formate is a colorless oil of strong and pleasant odor. According to the type of borneol used for its preparation, bornyl formate is

either dextro- or laevorotatory. Bruylants,¹ Bertram and Walbaum,^{2,3} Béhal,⁴ Tschugaev,⁵ Minguin and de Bollemont,⁶ and Gildemeister and Hoffmann⁷ reported the following properties:

b.	225°–230° ¹	α_D	+31° 0' ³
b ₂₁	106°–108° ⁴	$[\alpha]_D$	+48° 45' ⁴
b ₁₅	98°–99° ²		–48° 56' ⁴
b _{10–11}	90° ^{3,7}		–49° 0' ⁶ (in alcoholic solution)
b ₇	85°–86° ⁷		
d ₄ ²⁰	1.0058 ⁵	n _D ¹⁵	1.47078 ³
d ₁₅	1.017 ²		
d ₀	1.027 ⁴		

Use.—Bornyl formate is used on a very small scale in pine compositions.

¹ *Ber.* **11** (1878), 455.

² *J. prakt. Chem.* [2], **49** (1894), 7.

³ *Arch. Pharm.* **231** (1893), 305.

⁴ *Ann. chim. phys.* [7], **20** (1900), 421.

⁵ *Ber.* **31** (1898), 1775.

⁶ *Compt. rend.* **134** (1902), 609.

⁷ "Die Ätherischen Öle," 3d Ed., Vol. I, 648.

SUGGESTED ADDITIONAL LITERATURE

Th. Ruemele, "Action of Formic Esters in Perfumes," *Seifensieder-Ztg.* **67** (1940) 56, 65.

Bornyl Acetate

C₁₂H₂₀O₂

Mol. Weight 196.28

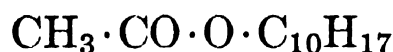

(See "Borneol")

Occurrence.—This important ester occurs in many oils distilled from leaves of plants belonging to the family *Pinaceae*—for example, in Siberian pine needle oil, oil of *Abies alba*, *Pinus pumilio*, and *P. picea*. Bornyl acetate has also been identified in several other volatile oils, such as coriander seed, and valerian root oil.

Isolation and Identification.—In order to isolate bornyl acetate, the fraction b. 220°–230° is cooled to a low temperature and inoculated with a bornyl acetate crystal. If the ester does not crystallize, the fraction should be saponified and the components identified as borneol and acetic acid.

Properties.—Optically active bornyl acetate is a crystalline substance, the inactive ester a liquid even at -17° , according to Haller.¹ In supercooled condition the ester may remain liquid for a long time. Bornyl acetate possesses a strong, pleasant and refreshing odor, typical of pine needles. The naturally occurring ester is mostly laevorotatory, while the rotation of a synthetic product depends upon that of the parent borneol (+ or -).

According to Lipp (née Bredt-Savelsberg) and Bund,² Moesveld,³ Takeuchi and Sahashi,⁴ and Haller,⁵ Bertram and Walbaum,^{6,7} Tschugaev,⁸ Kenyon and Pickard,⁹ Berner and Hjulstad,¹⁰ and Gildemeister and Hoffmann,¹¹ the optically active isomers of bornyl acetate have these properties:

<i>d</i> -Bornyl Acetate		<i>l</i> -Bornyl Acetate	
m.	27.7° ³	m.	27.4° ²
b.	225° – 226° ⁵	b.	225° – 226° ⁵
b ₁₅	106° – 107° ⁶	b ₁₅	107° ⁸
b ₈	93° ¹⁰	b ₁₃	105° ²
b ₄	80° – 81° ⁴		
d ₄ ³⁰	0.97715 ³	d ₄ ^{36.4}	0.9708 ²
d ₁₅	0.991 ⁶	d ₄ ²⁰	0.9868 ⁹
[α] _D	$+44^{\circ} 23'$ ⁵ (liquid)	[α] _D ²⁰	$-44^{\circ} 47'$ ² (c = 5.23 in ethyl alcohol)
[α] _D ²⁰	$+44^{\circ} 7'$ ¹⁰		
n _D ²⁰	1.4639 ¹⁰	n _D ^{36.4}	1.45689 ²
		n _D ¹⁵	1.46635 ⁷

Bornyl acetate is soluble in 3 volumes of 70 per cent alcohol.¹¹

Use.—Because of its characteristic pine odor and low price, bornyl acetate is used widely, serving as a valuable ingredient in pine oil compositions for the scenting of bath preparations, inhalants, room sprays, and soaps. The ester is employed also for the flavoring of medicinal preparations, cough drops, etc.

¹ *Compt. rend.* **109** (1889), 29.

² *Ber.* **68** (1935), 249.

³ *Koninklijke Akad. van Wetenschappen Te Amsterdam (Verslagen der Afdeling Natuurkundige)* **37** (1928), 823. *Chem. Abstracts* **23** (1929), 1553.

⁴ *Sci. Papers Inst. Phys. Chem. Research Tokyo* **22** (1933), 59. *Chem. Abstracts* **28** (1934), 1998.

⁵ *Compt. rend.* **109** (1889), 29.

⁶ *J. prakt. Chem.* [2], **49** (1894), 7, 12.

⁷ *Arch. Pharm.* **231** (1893), 304, 305.

⁸ *Ber.* **31** (1898), 1775.

⁹ *J. Chem. Soc.* **107** (1915), 51, 62.

¹⁰ *Ber.* **71** (1938), 2053.

¹¹ "Die Ätherischen Öle," 3d Ed., Vol. I, 649.

SUGGESTED ADDITIONAL LITERATURE

Georges Brus and J. Vébra, "Crystalline Complexes from Bornyl and Isobornyl Acetate," *Compt. rend.* **191** (1930), 667.

Pierre Bonichon, "Spectrographic Study of Terpenic Alcohols and Esters," *Bull. inst. pin* (1933), 249; (1934), 1, 32.

Haruo Tsuji, "The Effect of the Acetic Acid Ester and of Some Substituted Acetic Acid Esters of Borneol," *Tôhoku J. Exptl. Med.* **24** (1934), 374. *Chem. Abstracts* **29** (1935), 4828.

F. Feigl, V. Anger and O. Frehden, "Detection of Carboxylic Acids and Their Derivatives (Anhydrides, Esters and Halides)," *Mikrochemie* **15** (1934), 9.

Isobornyl Acetate

 $C_{12}H_{20}O_2$

Mol. Weight 196.28

 $CH_3 \cdot CO \cdot O \cdot C_{10}H_{17}$

(See "Isoborneol")

Occurrence.—So far this ester has not been found in nature, but should be described here because of its commercial importance.

Isolation.—By fractional distillation *in vacuo*.

Identification.—Saponify the ester and identify the components as isoborneol and acetic acid.

Properties.—Isobornyl acetate is liquid at room temperature. It possesses a slightly more camphoraceous odor than bornyl acetate.

The following properties have been reported by Lipp (née Bredt-Savelsberg) and Bund,¹ Kondakov,² Bertram and Walbaum,³ Tschugaev,⁴ Minguin and de Bollemont,⁵ Tsakalotos and Papaconstantinou,⁶ Fujita,⁷ and Lafont:⁸

dl-Isobornyl Acetate

b_{12-13}	102°–103° ^{1,2}	$n_D^{14.4}$	1.46589 ¹
d_{20}^{20}	0.9858 ²	n_D	1.46494 ²
d_4^{20}	0.9841 ²		
d_{15}	0.9905 ³		
$d_4^{14.4}$	0.98918 ¹		

As far as the optically active forms are concerned, it should be noted that the isobornyl acetate derived from *d*-camphene is slightly laevorotatory, and the ester derived from *l*-camphene dextrorotatory.

Optically Active Isobornyl Acetate

b.	ca. 225° ⁸	(from <i>l</i> -camphene)
b ₃₅	123°–127° ⁸	(from <i>l</i> -camphene)
b ₁₅	104°–107° ⁷	(from <i>l</i> -camphene)
b ₁₄	106° ⁵	(from <i>l</i> -isoborneol)
b ₁₂	97°–105° ⁶	(from <i>d</i> -camphene)
d ₄ ³⁰	0.9739 ⁷	(from <i>l</i> -camphene)
d ₁₅	0.991 ⁶	(from <i>d</i> -camphene)
d ₄ ⁰	0.9991 ⁷	(from <i>l</i> -camphene)
d ₀ ⁰	1.002 ⁸	(from <i>l</i> -camphene)
α _D	–2° 7' ⁵	(from <i>l</i> -isoborneol). (1.225 g. in 25 g. alcohol)
[α] _D	–3° 56' ⁶	(from <i>d</i> -camphene)
[α] _D ²¹	+1° 42' ⁷	(from <i>l</i> -camphene)
n _D ³⁰	1.4538 ⁷	(from <i>l</i> -camphene)

Use.—Synthetic isobornyl acetate is widely used in pine needle scents (see “Bornyl Acetate”).

¹ *Ber.* **68** (1935), 249.

² *J. prakt. Chem.* [2] **65** (1902), 225.

³ *Ibid.* [2], **49** (1894), 7, 12.

⁴ *Ber.* **31** (1898), 1775.

⁵ *Compt. rend.* **136** (1903), 239.

⁶ *J. pharm. chim.* [7], **7** (1916), 198. *Chem. Zentr.* II (1918), 24.

⁷ *Bull. Inst. Phys. Chem. Research Tokyo* **7** (1928), 1. *Chem. Abstracts* **22** (1928), 3406.

⁸ *Ann. Chim. Phys.* [6], **15** (1888), 149.

SUGGESTED ADDITIONAL LITERATURE

Georges Brus and J. Vébra, “Crystalline Complexes from Bornyl and Isobornyl Acetate,” *Compt. rend.* **191** (1930), 667.

Bornyl Isovalerate

(Bornyval)

C₁₅H₂₆O₂

Mol. Weight 238.36

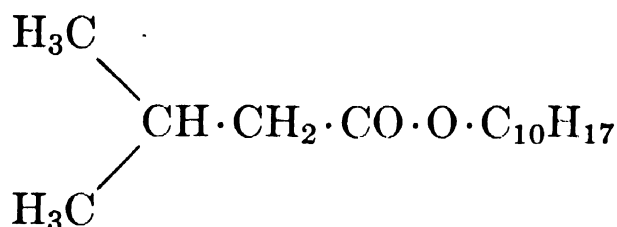

(See “Borneol”)

Occurrence.—This ester occurs in valerian root oil and in a few other essential oils.

Isolation.—By fractional distillation *in vacuo*.

Identification.—Saponify the ester and identify the components as borneol and iso-valeric acid.

Properties.—*d*-Bornyl isovalerate is a colorless oil of aromatic odor, reminiscent of valerian root and borneol. (Gildemeister and Hoffmann,¹ Bruylants,² Vavon and Peignier,³ and Siedler⁴ reported these properties for bornyl isovalerate:

b.	255°–260° ^{2,4}	$[\alpha]_{578}$	+36° 42' ³ (c = 0.05 in alc.)
b ₂₆	151°–152° ³	n _D ¹⁸	1.4605 ³
d ₄ ¹⁸	0.9486 ³	Sol.	Soluble in 4 vol. of 80% alcohol ¹

Bornyl isovalerate is not readily saponified. When assaying the ester quantitatively by saponification, it is, therefore, necessary to use a large excess of alkali and to heat the mixture for 6 hr. (See "Terpinyl Acetate," and Vol. I, Chapter 4, "The Examination and Analysis of Essential Oils, Synthetics, and Isolates," pp. 267 and 336.)

Use.—Bornyl isovalerate is used very little in our industries.

¹ "Die Ätherischen Öle," 3d Ed., Vol. I, 650.

² *Ber.* **11** (1878), 456.

³ *Bull. soc. chim.* [4], **39** (1926), 936.

⁴ *Pharm. Ztg.* **48** (1903), 772. *Chem. Zentr.* II (1903), 899.

Menthyl Acetate

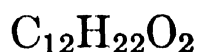

Mol. Weight 198.30

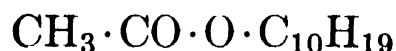

(See "Menthol")

Occurrence.—This ester has so far been identified only in peppermint oil.

Isolation.—By fractional distillation *in vacuo*.

Identification.—Saponify the ester and identify the components as menthol and acetic acid. (Cf. Vol. I of this work, p. 267.)

Properties.—Menthyl acetate is a colorless oil of pleasant fruity odor, reminiscent of peppermint. Kishner,¹ Tschugaev,² Patterson and Taylor,³ Kenyon and Pickard,⁴ Gildemeister and Hoffmann,⁵ Stadnikov,⁶ van Pelt and Wibaut,⁷ and Frank, Davis, Drake and McPherson⁸ reported these properties for *l*-menthyl acetate, comparable to the natural occurring isomer:

b.	227°–228° ^{1, 2}	α_D	–72° 47' to –73° 18' ^{5 *}
b ₂₂	115°–118° ⁸	$[\alpha]_D^{100}$	–78° 34' ^{4 *}
	116° ³	$[\alpha]_D^{80}$	–78° 53' ^{4 *}
b ₁₉	113° ⁶	$[\alpha]_D^{60}$	–78° 59' ^{4 *}
b ₁₅	110°–111° ⁷	$[\alpha]_D^{40}$	–79° 12' ^{4 *}
d ₄ ¹³²	0.8294 ⁴	$[\alpha]_D^{20}$	–79° 25' ^{2, 4 *}
d ₄ ⁹⁶	0.8617 ⁴	n_D^{20}	1.4472 ^{6, 8}
d ₄ ⁸⁰	0.8733 ⁴	Sol.	Soluble in 15 vol. of 65% alcohol; in 6 vol. of 70% alcohol ⁵
d ₄ ⁶⁰	0.8916 ⁴		
d ₄ ⁴⁰	0.9090 ⁴		
d ₄ ²⁰	0.9264 ⁴		
d ₁₃	0.9307 ³		

* Determinations made in homogeneous state.

According to Murayama and Tanaka,⁹ oxidation of menthyl acetate with chromium trioxide and acetic acid leads to an oil whose semicarbazone melts at 189°–190°.

Use.—Menthyl acetate is used in synthetic peppermint oils for the technical field. It also finds application, in very small percentages, to impart odor strength and “lift” to certain perfume and flavor compositions.

¹ *J. Russ. Phys. Chem. Soc.* **27** (1895), 480. See Gildemeister and Hoffmann, “Die Ätherischen Öle,” 3d Ed., Vol. I, 651.

² *Ber.* **31** (1898), 364; **35** (1902), 2475.

³ *J. Chem. Soc.* **87** (1905), 37.

⁴ *Ibid.* **107** (1915), 46, 60.

⁵ “Die Ätherischen Öle,” 3d Ed., Vol. I, 651.

⁶ *J. Russ. Phys. Chem. Soc.* **47** (1915), 1113.

⁷ *Rec. trav. chim.* **60** (1941), 55.

⁸ *J. Am. Chem. Soc.* **66** (1944), 1509.

⁹ *J. Pharm. Soc. Japan* **48** (1928), 429.

SUGGESTED ADDITIONAL LITERATURE

Matsuno and Han, “Raman Effect of Organic Substances,” *Bull. Chem. Soc. Japan* **11** (1936), 576. *Chem. Abstracts* **31** (1937), 4207.

L. H. Baldinger, “Hydrolysis of Menthyl Acetate and Acetylated Peppermint Oil,” *J. Am. Pharm. Assn.* **26** (1937), 208.

Henry C. Marks and Charles O. Beckmann, “The Rotivity of Dipropionyl-diethyl-*d*-tartrate and *l*-Menthyl Acetate in Aromatic and Aliphatic Solvents,” *J. Chem. Physics* **8** (1940), 831.

Menthyl Isovalerate

 $C_{15}H_{28}O_2$

Mol. Weight 240.37

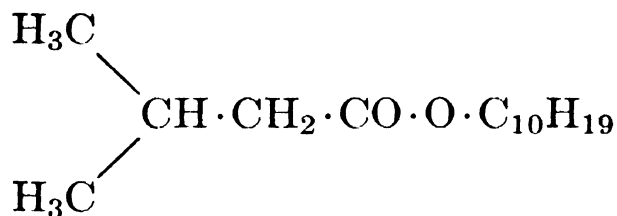

(See "Menthol")

Occurrence.—This ester has been identified in American, French, English and Russian peppermint oil.

Isolation.—By fractional distillation *in vacuo*.

Identification.—Saponify the ester and identify the components as menthol and isovaleric acid. Like most isovalerates, this ester is difficult to saponify; saponification of 1.5 g. of menthyl isovalerate requires boiling with 60 cc. of alcoholic 0.5 *N* potassium hydroxide solution for 6 to 8 hours. (Cf. Vol. I of this work, p. 267.)

Properties.—*l*-Menthyl isovalerate is a colorless oil with an odor reminiscent of both menthol and isovaleric acid.

Gildemeister and Hoffmann,¹ Rupe,² and Nekrasova³ reported these properties for synthetic menthyl isovalerate (95–100 per cent ester content):

b_{22}	$140^\circ\text{--}146^\circ$ ³	α_D	$-56^\circ 28'$ to $-57^\circ 40'$ ¹
b_9	129° ²	$[\alpha]_D^{20}$	$-64^\circ 12'$ ² (homogeneous)
d_{20}	0.8797 ²	n_D^{20}	$1.4461\text{--}1.4500$ ¹
d_{15}	0.907 ³	Sol.	Soluble in 5–9 vol. of 80% alcohol ¹

Use.—Menthyl isovalerate is used only to a small extent—for example, in the compounding of artificial peppermint oils serving for technical purposes.

¹ "Die Ätherischen Öle," 3d Ed., Vol. I, 651.

² *Liebigs Ann.* **369** (1909), 339.

³ *Arch. Pharm.* **266** (1928), 597.

C. AROMATIC ESTERS

Benzyl Acetate

 $C_9H_{10}O_2$

Mol. Weight 150.17

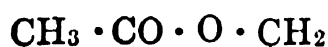

Occurrence.—This very important ester is the main constituent of jasmine, hyacinth and gardenia flower oil. It also occurs in oil of ylang ylang, and several other essential oils.

Isolation.—By fractional distillation *in vacuo*.

Identification.—On saponification benzyl acetate yields benzyl alcohol and an acetate. Identification of the component alcohol and acid is described elsewhere in this work.

Properties.—Benzyl acetate is a colorless, optically inactive oil. It possesses a powerful, fruity and flowery odor, reminiscent of jasmine.

Gildemeister and Hoffmann,¹ Hesse and Zeitschel,² Debrosserdov,³ Thole,⁴ Herold,⁵ Szamatolski and Austin,⁶ Shapiro,⁷ Sivkov and Matveeva,⁸ von Rechenberg,⁹ Zaganiaris and Varvoglis,¹⁰ and Berner and Hjulstad¹¹ reported these properties for synthetic benzyl acetate:

b ₈₀₀	217.4° ⁹	d ₄₅	1.033 ⁴
b.	216° ^{5,10}	d ₂₅	1.052 ⁶
	214°–215° ⁶	d ₂₀	1.0562 ⁸
b ₆₀₀	206° ⁹	d ₁₅ ^{18.5}	1.0587 ³
b ₄₀₀	190.5° ⁹	d ₁₅	1.060 ⁶
b ₂₀₀	167.25° ⁹	n _D ²⁰	1.5029 ¹¹
b ₁₀₀	146.7° ⁹	Sol.	Slightly soluble in water; soluble in all proportions in alcohol and ether
b ₅₀	128.75° ⁹		Soluble in: ¹
b ₂₅	110°–111° ²		200 vol. of 30% alcohol
b ₂₀	107.5° ⁹		120 vol. of 35% alcohol
b ₁₄	102° ¹¹		70 vol. of 40% alcohol
b ₁₀	93°–94° ⁷		20 vol. of 50% alcohol
b ₄	77.4° ⁹		5–6 vol. of 60% alcohol
			2 vol. of 70% alcohol

When examining commercial benzyl acetate, it is advisable to test also for the presence (absence!) of chlorine which contamination might be due to improper purification after synthesis.

Use.—Benzyl acetate is most widely used in practically all types of perfume compositions. This is equally true of cosmetics and the scenting of soaps. High odor value combined with low cost make this ester one of the most important aromatics. It has its place also in artificial fruit flavors.

- ¹ "Die Ätherischen Öle," 3d Ed., Vol. I, 644.
- ² *J. prakt. Chem.* [2], **64** (1901), 256.
- ³ *Chem. Zentr.* I (1911), 954.
- ⁴ *J. Chem. Soc.* **97** (1910), 2600.
- ⁵ *Deut. Parfümerieztg.* **17** (1931), 362. *Chem. Abstracts* **26** (1932), 3072.
- ⁶ *Ind. Eng. Chem., News Ed.* **11** (1933), 114.
- ⁷ *Maslobožno Zhirovoe Delo* **11** (1935), 321. *Chem. Abstracts* **30** (1936), 723.
- ⁸ *Sintezy Dushistykh Veshchestv, Sbornik Statei* (1939), 154. *Chem. Abstracts* **36** (1942), 3793.
- ⁹ Schimmel & Co., "Einfache und fraktionierte Destillation in Theorie und Praxis," Leipzig (1923), 257.
- ¹⁰ *Ber.* **69** (1936), 2280.
- ¹¹ *Ber.* **71** (1938), 2053.

SUGGESTED ADDITIONAL LITERATURE

Endre Berner and Arnfinn Hjulstad, "Catalytic Action of Metal Surfaces in the Interchange of Ester Radicals," *Ber.* **71B** (1938), 2052. *Chem. Abstracts* **33** (1939), 458.

H. S. Redgrove, "Two Jasmine Constituents," *Mfg. Perfumer* **4** (1939), 59.

Dinakar Karvé and V. L. Mehendale, "Kinetics of Reactions of Heterogeneous Systems. Hydrolysis of Benzyl Acetate, Butyl Acetate and Isoamyl Acetate by Hydrochloric Acid," *J. Univ. Bombay* **8**, Part 3 (1939), 160. *Chem. Abstracts* **34** (1940), 3161.

G. V. L. N. Murty and T. R. Seshadri, "Raman Effect and Chemical Constitution. Effect of Benzyl Group on C=O Bond in Esters," *Proc. Indian Acad. Sci.* **11A** (1940), 32. *Chem. Abstracts* **34** (1940), 6881.

Methyl Benzoate

$C_8H_8O_2$

Mol. Weight 136.14

Benzoic acid methyl ester. "Oil of niobe"

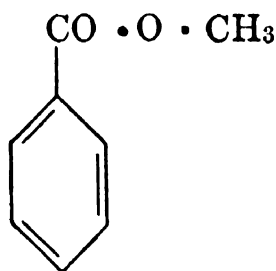

Occurrence.—Methyl benzoate occurs in oil of ylang ylang, probably also in oil of clove and tuberose.

Isolation.—By fractional distillation *in vacuo*.

Identification.—Saponify the ester and identify the components as benzoic acid and methyl alcohol.

Direct aminolysis of the ester by means of benzyl amine, according to Dermer and King,¹ yields the benzylamide of benzoic acid, m. 105°–105.5°. This technique facilitates identification of methyl benzoate.

Properties.—Methyl benzoate is an oil, optically inactive, of powerful, rather harsh floral odor. The following properties have been reported by Timmermans and Hennaut-Roland,² Timmermans,³ Jaeger,⁴ von Auwers and Eisenlohr,⁵ Perkin,⁶ Kendall and Booge,⁷ and Gildemeister and Hoffmann:⁸

m.	−12.5° to −12.3° ^{2,3,7}	n_D^{16}	1.5181 ⁵
	−13.7° ⁷ (metastable crystalline form)	n_D^{15}	1.51924 ²
		Sol.	Soluble in 4 vol. of 60% alcohol, soluble in 1.5 vol. of 70% alcohol ⁸
b.	199.5° ²		
b ₁₁	83° ⁵		
d ₄ ^{192.5}	0.902 ⁴		
d ₄ ³⁰	1.07901 ²		
d ₄ ²⁵	1.08384 ²		
d ₄ ²⁰	1.08859 ²		
d ₄ ¹⁶	1.09239 ²		
d ₁₀ ¹⁰	1.0983 ⁶		
d ₄ ⁰	1.10767 ²		

According to Raikow,⁹ methyl benzoate, unlike the esters of the homologous alcohols, forms a crystalline compound with phosphoric acid.

Use.—Because of its powerful odor and low price, methyl benzoate is used primarily in perfume compositions serving for the scenting of soaps. It is an important constituent in synthetic ylang ylang oils.

¹ *J. Org. Chem.* **8** (1943), 168.

² *J. chim. phys.* **32** (1935), 589.

³ *Bull. soc. chim. Belg.* **27** (1913), 334.

⁴ *Z. anorg. Chem.* **101** (1917), 137.

⁵ *J. prakt. Chem.* [2], **84** (1911), 24.

⁶ *J. Chem. Soc.* **69** (1896), 1174.

⁷ *J. Am. Chem. Soc.* **38** (1916), 1721.

⁸ "Die Ätherischen Öle," 3d Ed., Vol. I, 633.

⁹ *Chem. Ztg.* **24** (1900), 368.

Ethyl Benzoate

C₉H₁₀O₂

Mol. Weight 150.17

Benzoic acid ethyl ester

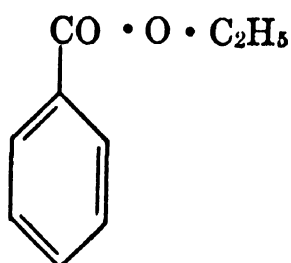

Occurrence.—Although not definitely proved, the occurrence of this ester in volatile oils is probable.

Isolation.—By fractional distillation *in vacuo*.

Identification.—Saponify the ester and identify the components as ethyl alcohol and benzoic acid.

Feigl, Anger and Frehden¹ describe the micro detection of ethyl benzoate with hydroxamic acid and ferric chloride; this metallic complex yields a violet color in concentrations for as little as 5 γ of the ester.

A direct derivative may be obtained, according to Dermer and King,² by the reaction of benzylamine and the ester to form the N-benzylamide of benzoic acid, m. 105°–105.5°.

Properties.—Ethyl benzoate possesses an odor similar to, but milder than that of methyl benzoate. The following properties have been reported by Timmermans and Hennaut-Roland,³ Kremann, Meingast and Gugl,⁴ Lumsden,⁵ Timmermans,⁶ von Rechenberg,⁷ Matsuno and Han,⁸ Bhatkhande, Phalnikar and Bhide,⁹ Petyunin,¹⁰ Evans, Gordon and Watson,¹¹ de Benneville, Clagett, and Connor,¹² Perkin,¹³ von Auwers and Eisenlohr,¹⁴ and Gilde-meister and Hoffmann:¹⁵

m.	−34.7° ³	$n_D^{17.3}$	1.5068 ¹⁴
	−34.2° ⁶	n_D^{15}	1.50790 ⁵
b.	212°–213° ^{3, 7, 8, 9}	Sol.	Soluble in 7.5 vol. of 60% alcohol; in 2 vol. of 70% alcohol ¹⁵
$b_{739.7}$	211° ⁷		
b_{100}	142.2° ⁷		
b_{20}	103° ¹¹		
b_9	89°–99° ¹²		
d_4^{69}	1.0016 ⁴		
$d_4^{57.5}$	1.0125 ⁴		
d_4^{30}	1.03718 ³		
d_4^{25}	1.04192 ³		
	1.04652 ³		
d_4^{15}	1.05112 ³		
d_{10}^{10}	1.0562 ¹³		
	1.05578 ³		
d_4^0	1.06498 ³		

Sen and Mukherji¹⁶ reported on the 1:1 condensation of ethyl benzoate with resorcinol by zinc chloride to prepare 2,4-dihydroxy benzophenone, a yellow powder melting at 144°.

Use.—Similar to that of methyl benzoate.

¹ *Mikrochemie* **15** (1934), 9.

² *J. Org. Chem.* **8** (1943), 168.

³ *J. chim. phys.* **32** (1935), 591.

⁴ *Monatsh.* **35** (1914), 1287.

⁵ *J. Chem. Soc.* **87** (1905), 94.

⁶ *Bull. soc. chim. Belg.* **25** (1911), 313.

- ⁷ Schimmel & Co., "Einfache und fraktionierte Destillation in Theorie und Praxis," Leipzig (1923).
- ⁸ *Bull. Chem. Soc. Japan* **8** (1933), 338. *Chem. Abstracts* **28** (1934), 1927.
- ⁹ *J. Univ. Bombay* **10**, Part 3 (1941), 53. *Chem. Abstracts* **36** (1942), 5068.
- ¹⁰ *J. Gen. Chem. U.S.S.R.* **10** (1940), 35. *Chem. Abstracts* **34** (1940), 4726.
- ¹¹ *J. Chem. Soc.* (1937), 1432.
- ¹² *J. Org. Chem.* **6** (1941), 691.
- ¹³ *J. Chem. Soc.* **69** (1896), 1174.
- ¹⁴ *J. prakt. Chem.* [2], **82** (1910), 167.
- ¹⁵ "Die Ätherischen Öle," 3d Ed., Vol. I, 638.
- ¹⁶ *J. Indian Chem. Soc.* **6** (1929), 560.

SUGGESTED ADDITIONAL LITERATURE

R. A. Fairclough and C. N. Hinshelwood, "The Functional Relation between the Constants of the Arrhenius Equation," *J. Chem. Soc.* (1937), 538.

Fellinger and Audrieth, "Ammonolysis of Ethyl Benzoate," *J. Am. Chem. Soc.* **60** (1938), 579.

A. A. Shamshurin, "Action of Pyrocarbonates in Grignard Reagents," *J. Gen. Chem. U.S.S.R.* **13** (1943), 569. *Chem. Abstracts* **39** (1945), 700.

Benzyl Benzoate

C₁₄H₁₂O₂

Mol. Weight 212.24

Benzoic acid benzyl ester

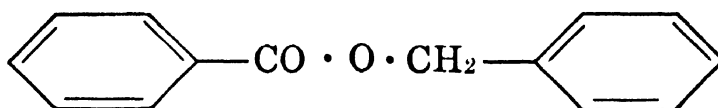

Occurrence.—This important ester occurs in several essential oils—for example, in oil of ylang ylang, balsam tolu, in tuberose flower oil, etc. It forms the main constituent of the oil derived from balsam Peru ("cinnamein").

Isolation.—By cooling the corresponding fraction to a low temperature, and recrystallization.

Identification.—Saponify the ester and identify the components as benzoic acid and benzyl alcohol.

Properties.—Benzyl benzoate is an optically inactive, somewhat viscid oil which congeals at low temperature to white crystals m. 20°. It is sparingly volatile with steam. The pure ester possesses only a faint odor.

The following properties have been reported by Reznek,¹ Gildemeister and Hoffmann,² Mascarelli,³ Zonev,⁴ and Cotton and Mouton:⁵

m.	19°–20° ²	d ₂₀ ²⁰	1.120 ¹
b.	325°–327° ¹	n _D ²⁵	1.5665 ¹
b ₁₈	189°–191° ³	n _D ^{21.5}	1.5685 ⁵
b ₁₅	183°–184° ⁴	Sol.	Soluble in 10–12 vol. of 80% alcohol, or in 1.5–2 vol. of 90% alcohol ²
b _{4.5}	156° ²		

Use.—Benzyl benzoate is used most widely as a diluent and solvent of solid aromatics—for example, of artificial musk. Because of its low volatility this ester also serves as a fixative in perfume compositions.

¹ *J. Assocn. Off. Agr. Chem.* **20** (1937), 560.

² "Die Ätherischen Öle," 3d Ed., Vol. I, 645.

³ *Atti accad. Lincei* [5], **19**, Part I (1910), 385.

⁴ *J. Russ. Phys. Chem. Soc.* **48** (1916), 577.

⁵ *Ann. chim. phys.* [8], **28** (1913), 218.

SUGGESTED ADDITIONAL LITERATURE

Eberhard Postel, "Benzyl Benzoate, a Constituent of Peru Balsam," *Klin. Wochschr.* **22** (1943), 362. *Chem. Abstracts* **39** (1945), 4964.

R. M. Gordon and K. Unsworth, "The Lethal Action of Benzyl Benzoate, Dimethylthianthrene (Mitigal) and Tetraethylthiuram Monosulfide (Tetmos) on the Scabies-producing Mites, *Notoedres Sp.* and *Sarcoptes scabiei* var. *hominis*, when Tested *in Vitro*," *Ann. Trop. Med.* **37** (1943), 195. *Chem. Abstracts* **39** (1945), 365.

Methyl Salicylate

$C_8H_8O_3$

Mol. Weight 152.14

Salicylic acid methyl ester. Methyl *o*-hydroxybenzoate

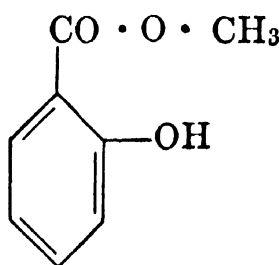

Occurrence.—Methyl salicylate occurs in many essential oils, and forms the main constituent of some oils. Oil of wintergreen (*Gaultheria procumbens*) and sweet birch (*Betula lenta*), for example, contain up to 99 per cent methyl salicylate. The ester has also been identified in oil of ylang ylang, rue, clove, American wormseed, in tuberose and cassia flower oil, green tea, and a number of others.

It is an interesting fact that in several aromatic plants—wintergreen, for instance—methyl salicylate does not occur as such, but in the form of a glucoside (gaultherin) which must first be split by enzyme action in order to liberate the ester. Without previous digestion in lukewarm water for several hours, the plant material on distillation would yield almost no oil.

Isolation.—By fractional distillation *in vacuo*.

Identification.—Saponify the ester and identify the components as salicylic acid m. 158° and methyl alcohol.

Otherwise methyl salicylate can be characterized by the preparation of several derivatives:

(1) Methyl salicylate in an ice cold alkaline solution on shaking with acetic anhydride yields, according to Chattaway,¹ methyl *o*-acetoxybenzoate m. 52°–52.5°.

(2) Methyl salicylate in a cold dilute alkaline solution on shaking with benzoyl chloride yields, according to Lassar-Cohn and Löwenstein,² methyl *o*-benzoxybenzoate m. 92° (from alcohol or ether).

(3) On treatment with an equal weight of phenylisocyanate and a trace of sodium acetate for 5 hr. at 100°, methyl salicylate yields *o*-carbomethoxyphenyl-N-phenylurethane m. 117° (crystallized from benzene), according to Michael and Cobb.³

(4) Capryl chloride and methyl salicylate yield methyl-2-(capryloxy)benzoate, which with a Fries rearrangement gives methyl-4-capryl salicylate m. 66.5°–67.5°. Hydrolysis of the ester forms 4-caprylsalicylic acid m. 120.5°–121.5° (Price and May⁴).

(5) Antipyrinic acid chloride in pyridine on treatment with methyl salicylate yields the *o*-carbomethoxyphenyl ester m. 138° (Kaufmann et al.⁵).

(6) For the preparation of methyl 3,5-dinitrobenzoyl salicylate, Saunders, Stacey and Wilding⁶ recommend the following procedure:

Triturate for 2 min. in a small mortar 2.31 g. of 3,5-dinitrobenzoyl chloride, 1.52 g. of methyl salicylate, and 10 ml. of N sodium hydroxide. Treat the reaction mixture with ether; recrystallize the methyl 3,5-dinitrobenzoyl salicylate from a mixture of chloroform and petroleum ether: m. 107.5°.

Properties.—Methyl salicylate is a colorless oil, possessing a powerful odor and flavor very characteristic of wintergreen.

The following properties have been reported by von Schneider,⁷ Perkin,⁸ Hoyer,⁹ Schreiner,¹⁰ Gildemeister and Hoffmann,¹¹ and Nozu et al.:¹²

m.	−8.3° ⁷ (corr.)	d_{15}^{15}	1.188–1.191 ¹¹
b.	224° ¹²	d_{15}^{15}	1.1890 ⁸
b ₇₅₁	221.5°–222° ⁹	d_4^4	1.1992 ⁸
b ₇₃₀	217° ¹⁰	n_D^{20}	1.535–1.538 ¹¹
Sol.	Soluble in 6–8 vol. of 70% alcohol. Sparingly soluble in water ¹¹		

On addition of ferric chloride in cold saturated aqueous solution, methyl salicylate develops a red-violet color which lasts for at least 15 min.

In a moderately concentrated aqueous solution of potassium hydroxide, methyl salicylate dissolves with formation of a readily soluble ester salt (potassium methyl salicylate). By the action of dilute acids, the methyl salicylate can be regenerated from the alkaline solution. Methyl salicylate is soluble also in a very dilute aqueous sodium hydroxide solution, but in 3 per cent or stronger sodium hydroxide solution the sparingly soluble sodium methyl salicylate precipitates. When heated with excess alkali both ester salts (Na and K- salt) are saponified, and on acidification salicylic acid will be obtained.

Use.—Methyl salicylate is used most widely in the flavoring of chewing gums, candies, confectionery, and all kinds of food products and beverages. As one of the most popular flavors in the United States, it also serves in oral preparations, tooth pastes, and pharmaceutical products. Another but more limited use is in cosmetics and as an adjunct for the scenting of soaps.

¹ *J. Chem. Soc.* (1931), 2495.

² *Ber.* **41** (1908), 3363.

- ³ *Liebigs Ann.* **363** (1908), 86.
⁴ *J. Am. Chem. Soc.* **65** (1943), 297.
⁵ *Ber.* **75** (1942), 1226.
⁶ *Biochem. J.* **36** (1942), 373. See also Sah and Ma, *Science Repts. Natl. Tsing Hua Univ. Ser. A-1* (1932), 203.
⁷ *Z. physik. Chem.* **22** (1897), 233.
⁸ *J. Chem. Soc.* **69** (1896), 1176.
⁹ *Z. physik. Chem. Abt. B* **45** (1940), 401.
¹⁰ *Liebigs Ann.* **197** (1879), 17.
¹¹ "Die Ätherischen Öle," 3d Ed., Vol. I, 637.
¹² *J. Chem. Soc. Japan* **60** (1939), 1189. *Chem. Abstracts* **36** (1942), 6513.

SUGGESTED ADDITIONAL LITERATURE

F. Feigl, V. Anger and O. Frehden, "Detection of Carboxylic Acid and Its Derivatives (Anhydrides, Esters and Halides)," *Mikrochemie* **15** (1934), 9.

Ethyl Salicylate

C₉H₁₀O₃

Mol. Weight 166.17

Salicylic acid ethyl ester

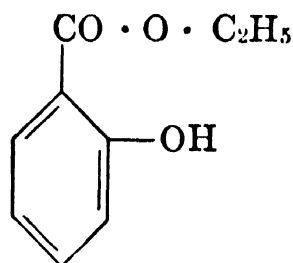

Occurrence.—The occurrence of this ester in essential oils is possible, but has not been definitely proved.

Isolation.—By fractional distillation *in vacuo*, or by cooling the fraction rich in ethyl salicylate to a low temperature whereby the ester will separate in crystalline form.

Identification.—(1) Saponify the ester and identify the components as ethyl alcohol and salicylic acid.

(2) By the preparation of derivatives:

(a) Treatment of ethyl salicylate with *p*-nitrobenzoyl chloride in pyridine, and standing overnight at ordinary temperature yields ethyl *o*-(*p*-nitrobenzoxy) benzoate m. 107°–108° (crystallized from benzene), according to Einhorn and von Bagh.¹

(b) Nitration at 0° with 5 parts of a mixture of equal volumes of fuming nitric acid and fuming sulfuric acid yields ethyl 3,5-dinitrosalicylate m. 92°–93° (crystallized from alcohol), according to Sah and Ma.²

Properties.—Ethyl salicylate is a colorless oil, possessing an odor similar to, but weaker than, methyl salicylate. Von Schneider,³ Hoyer,⁴ Gildemeister and Hoffmann,⁵ and Sah and Ma⁶ reported these properties:

m.	1.3° ³	b ₅	91° ⁵
b ₇₄₃	234°–235° ⁵	d ₄ ²⁰	1.1396 ⁶
	233° ⁴	n _D ²⁰	1.52542 ⁶

Sol. Soluble in 4 vol. of 80% alcohol⁵

Ethyl salicylate is sparingly soluble in water; soluble in dilute sodium hydroxide solution (6 per cent or less), but in more concentrated sodium hydroxide solutions the sodium salt of this phenolic ester will precipitate.

With cold saturated aqueous ferric chloride solution ethyl salicylate immediately gives a red-violet color.

Use.—Ethyl salicylate is used like methyl salicylate, but only to a very limited degree.

¹ *Ber.* **43** (1910), 329.

² *Science Repts. Natl. Tsing Hua Univ.* Ser. A-1 (1932), 203.

³ *Z. physik. Chem.* **19** (1896), 158.

⁴ *Ibid.* Abt. B **45** (1940), 400.

⁵ "Die Ätherischen Öle," 3d Ed., Vol. I, 638.

⁶ *Science Repts. Natl. Tsing Hua Univ.* Ser. A-1 (1932), 203.

SUGGESTED ADDITIONAL LITERATURE

Charles Valencian and Jean Deshusses, "The Identification and the Bromometric Determination of the Esters of Salicylic Acid," *Mitt. Lebensm. Hyg.* **30** (1939), 85.

Isoamyl Salicylate

$C_{12}H_{16}O_3$

Mol. Weight 208.25

Salicylic acid isoamyl ester

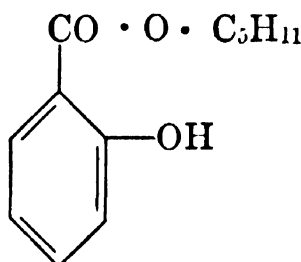

Theoretically eight isomeric amyl salicylates may exist of which isoamyl salicylate and *n*-amyl salicylate are most easily prepared and usually referred to in the literature. The commercially available product consists mainly of isoamyl salicylate. Freeman and Haller¹ described the preparation and properties of primary, secondary, and tertiary amyl salicylates.

Occurrence.—Isoamyl salicylate has not yet been identified in nature.

Isolation.—By fractional distillation *in vacuo*.

Identification.—(1) Saponify the ester and identify the components as isoamyl alcohol and salicylic acid. Isoamyl salicylate, like most salicylic esters, is not readily saponified. For complete saponification a large excess of alkali should be used and the mixture heated on the steam bath for at least 2 hr.

(2) When nitrated at 0° with 5 parts of a mixture of equal volumes of fuming nitric acid and fuming sulfuric acid, isoamyl salicylate, according to Sah and Ma,² yields isoamyl 3,5-dinitrosalicylate m. 61°–62° (crystallized from alcohol).

Properties.—Isoamyl salicylate is a colorless oil, possessing a strong and lasting odor, reminiscent of orchids and hay. Gildemeister and Hoffmann,³ and Sah and Ma⁴ reported these properties for the synthetic product:

b.	276°–278° ⁴	α_D	Up to +2° 50' ³
b ₇₄₃	276°–277° ³	n_D^{20}	1.505–1.508 ³
b ₁₅	151°–152° ³		1.50799 ⁴
d_4^{20}	1.0535 ⁴	Sol.	Soluble in 3 vol. of 90% alcohol ³
d_{15}^{15}	1.049–1.056 ³		

Isoamyl salicylate is soluble in dilute (1 per cent or less) sodium hydroxide solution, but in more concentrated alkaline solutions the sodium salt of this phenolic ester will precipitate.

Use.—Isoamyl salicylate is widely used by the perfume and cosmetic industry in compositions of the orchid, trefle, new mown hay, carnation and chypre type. Because of its strong odor, stability and low price, this ester serves very well for the scenting of soaps.

Scott and Milam⁵ also reported isoamyl salicylate as an attractant for hornworm moths.

¹ *J. Am. Chem. Soc.* **60** (1938), 2274.

² *Science Repts. Natl. Tsing Hua Univ. Ser. A-1* (1932), 203.

³ "Die Ätherischen Öle," 3d Ed., Vol. I, 639.

⁴ *Science Repts. Natl. Tsing Hua Univ. Ser. A-1* (1932), 203.

⁵ *J. Econ. Entomol.* **36** (1943), 712. *Chem. Abstracts* **38** (1944), 1315.

Methyl Cinnamate

C₁₀H₁₀O₂

Mol. Weight 162.18

Cinnamic acid methyl ester

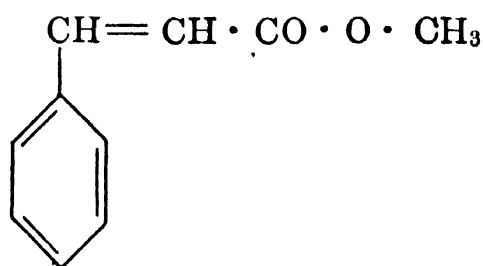

Occurrence.—Methyl cinnamate is a main constituent of certain types of *Ocimum canum* oil; it also occurs in the oil distilled from *Alpinia galanga*, and in a few other oils. Rakshit¹ reported oil of *Ocimum basilicum* from North India to contain 52 per cent of this ester.

Isolation.—By cooling the corresponding fraction of the oil to a low temperature, and recrystallization.

Rakshit² separated methyl cinnamate (*trans*-form) from *l*-linaloöl by the formation of a calcium chloride addition product. The formation of this addition compound does not appear to have been observed previously. The dried oil (36 cc.), after washing

with sodium carbonate solution, was mixed with freshly fused and finely powdered calcium chloride (40 g.) and kept in a desiccator for 48 hr. After removal of *l*-linaloöl by extraction with ether the calcium chloride compound was decomposed by water and distilled.

Identification.—Saponify the ester and identify the components as methanol and cinnamic acid.

For further methods of identification, see section on properties relative to direct halogenation.

Identification of the isomers may be effected directly by employing the mercuration technique of Wright: ³

Trans- form. To a solution of 3.18 g. (0.01 mol) of mercuric acetate in 25 cc. methanol, add 0.05 g. of concentrated nitric acid followed by 1.94 g. (0.012 mol) of methyl cinnamate. After standing 75 min. at 25°, an acetoxymurcuric compound will crystallize in the reaction mixture, which should be immediately filtered off, m. 142°. Treat the filtrate with dilute sodium chloride solution to yield methyl- α -chloromercuri- β -methoxy- β -phenylpropionate m. 134° (88% yield).

Cis- form. Filter a solution of 1.78 g. (0.011 mol) of *cis*-methyl cinnamate and 3.18 g. of mercuric acetate in 25 cc. of methanol after 9 hr. and treat the filtrate with 2% sodium chloride solution. Crystallize the precipitated methyl- α -chloromercuri- β -methoxy- β -phenylpropionate from ethanol, m. 141° (50% yield).

A mixed melting point with the diastereomer obtained from *trans*-methyl cinnamate (134°) was lowered 20°.

Properties.—Methyl cinnamate possesses a strong, lasting, rather peculiar odor.

Two isomers of methyl cinnamate are possible, the *trans*- stereoisomer usually being called methyl cinnamate and the *cis*- form methyl *allo*-cinnamate.

The following properties have been reported by Jaeger,⁴ Weger,⁵ Rakshit,⁶ and Gildemeister and Hoffmann:⁷

Trans-methyl Cinnamate

m.	36.5° ⁴	n_D^{40}	1.563–1.566 ⁷
	36° ^{5,6}	n_D^{20}	1.56704 ⁶
b.	254°–255° ⁶	Sol.	Soluble in 7 vol. of 70% alcohol at 20°; in 2–4 vol. at 30°–40° ⁷
d_4^{75}	1.0340 ⁴		
d_4^{50}	1.0573 ⁴		
d_4^{35}	1.0700 ⁴		
d_{15}	1.0672 ⁶		

Block ⁸ also measured the specific gravity of crystalline methyl cinnamate over the range 0° to 21°, and liquid methyl cinnamate between 19° and 48°.

On treating *trans*-methyl cinnamate with chlorine in carbontetrachloride in the presence of sunlight Brühl ⁹ observed an almost complete conversion into methyl cinnamate dichloride (m. 101°, according to Sudborough and James ¹⁰). In the presence of diffuse light a mixture of the *trans*- with the oily methyl

allo-cinnamate dichloride is formed, while in the dark, according to Michael and Smith,¹¹ this reaction yields only the *allo*-dichloride product. The same authors also noted an analogous behavior in the formation of the methyl cinnamate dibromides. Rakshit¹² reports the bromine derivative to melt at 114°.

Cis- or Methyl Allo-cinnamate.—*Cis-* or methyl *allo*-cinnamate is an oil at room temperature. Riiber,¹³ Wright,¹⁴ and Kistiakowsky and Smith¹⁵ recorded the following properties:

m.	−3.5° ¹⁵	b _{0.1}	49° ¹³
	−3° ¹⁴	n _D ²⁰	1.5528 ¹⁵

Kistiakowsky and Smith¹⁶ also observed the characteristic freezing point curve of the *cis-* and *trans*-methyl cinnamates. According to Riiber,¹⁷ methyl *allo*-cinnamate forms β -phenylglyceric acid m. 121° on oxidation with potassium permanganate solution in presence of potassium carbonate at −15° to −17°.

Use.—Methyl cinnamate is used in oriental and in floral perfume compositions, especially of the carnation type. It is an excellent fixative and blender in soap perfumes.

¹ *Perfumery Essential Oil Record* **29** (1938), 89.

² *Ibid.*

³ *J. Am. Chem. Soc.* **57** (1935), 1993. See also Schrauth, Schoeller and Struensee, *Ber.* **43** (1910), 695.

⁴ *Z. anorg. Chem.* **101** (1917), 140.

⁵ *Liebigs Ann.* **221** (1883), 74.

⁶ *Perfumery Essential Oil Record* **29** (1938), 89.

⁷ "Die Ätherischen Öle," 3d Ed., Vol. I, 633.

⁸ *Z. physik. Chem.* **78** (1912), 413.

⁹ *Ber.* **29** (1896), 2907.

¹⁰ *J. Chem. Soc.* **89** (1906), 106.

¹¹ *Am. Chem. J.* **39** (1908), 25.

¹² *Perfumery Essential Oil Record* **29** (1938), 89.

¹³ *Ber.* **41** (1908), 2415; **48** (1915), 828. See also Weerman, *Rec. trav. chim.* **37** (1918), 43.

¹⁴ *J. Am. Chem. Soc.* **57** (1935), 1993.

¹⁵ *Ibid.*, 269.

¹⁶ *Ibid.*

¹⁷ *Ber.* **41** (1908), 2415; **48** (1915), 828.

SUGGESTED ADDITIONAL LITERATURE

Ryoichi Kubo, "Catalytic Action Under High Pressure and High Temperature. Catalytic Reduction of Cinnamic Acid Methyl Ester and Its Derivatives," *J. Chem. Soc. Japan* **54** (1933), 509. *Chem. Abstracts* **27** (1933), 5732.

Seishi Takaki and Takeo Ueda, "Action of Ammonium Amalgam on α,β -Unsaturated Acid Esters," *J. Pharm. Soc. Japan* **58** (1938), 427. *Chem. Abstracts* **32** (1938), 6636.

Osamu Simamura, "The Isomerization of Methyl *Allo*-cinnamate by Hydrogen Bromide and the Influence of Oxygen," *Bull. Chem. Soc. Japan* **14** (1939), 294. *Chem. Abstracts* **33** (1939), 8592.

Ethyl Cinnamate

 $C_{11}H_{12}O_2$

Mol. Weight 176.21

Cinnamic acid ethyl ester

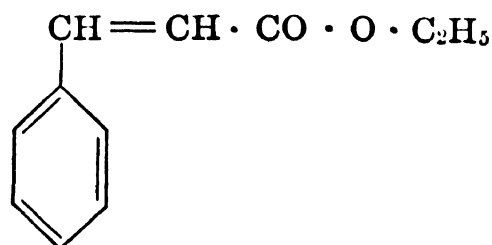

Occurrence.—This ester occurs only in a few essential oils—for instance, in oil of styrax and in oil of *Campheria galanga*.

Isolation.—By fractional distillation *in vacuo*.

Identification.—Saponify the ester and identify the components as ethyl alcohol and cinnamic acid. See section on “Properties” relative to halogen derivatives. Pfeiffer¹ reports that stannic chloride and ethyl cinnamate form a double salt $[2C_{11}H_{12}O_2]\cdot SnCl_4$; m. 134° .

Diels and Heintzel² prepared the cinnamoyl urethane m. 110° – 111° directly from the ester and sodium urethane.

Jerzmanowska-Sienkiewiczowa,³ obtained the ureide m. 207° – 209° from sodium alcoholate, urea, and ethyl cinnamate in 24% yield only.

Properties.—Ethyl cinnamate is a liquid, optically inactive, which congeals at low temperature. It possesses a strong, lasting, pleasant, somewhat fruity odor. The following properties for the geometric isomers have been reported by Weger,⁴ Anschütz and Kinnicutt,⁵ Brühl,⁶ Perkin,⁷ Bergmann,⁸ Marvel and King,⁹ Duquenois,¹⁰ Manta,¹¹ Roth and von Auwers,¹² Jaeger,¹³ and Williams and Sudborough:¹⁴

	<i>Trans-</i>		<i>Cis-</i>
m.	12° ^{4,10}		
$b_{767.5}$	272.6° – 272.8° ¹⁴	b_{17}	131° – 134° ⁸
b.	271° ^{4,5,10}		133° ¹¹
$b_{741.1}$	267° – 268° ⁶		
b_{250}	226° ⁷ (corr.)		
b_{46}	168° – 173° ⁹		
b_{22}	149° ¹¹		
b_{15}	144° ¹²		
d_4^{75}	1.0018 ¹³		
d_4^{50}	1.0234 ¹³		
d_4^{25}	1.0457 ¹³		
d_4^{20}	1.0490 ⁶		
$d_4^{16.8}$	1.0519 ¹²		

	<i>Trans-</i>		<i>Cis-</i>
n_D^{20}	1.55982 ⁶	n_D^{14}	1.5450 ¹¹
	1.5597 ¹²		
n_D^{14}	1.5603 ¹¹		
$n_D^{12.9}$	1.56351 ⁷		
Sol.	Soluble in 4-7 vol. of 70% alcohol (Gilde- meister and Hoffmann)		

The *trans*- form is the one ordinarily encountered. The *cis*- isomer or ethyl *allo*-cinnamate is a liquid.

According to Michael,¹⁵ on the addition of bromine in carbontetrachloride or carbondisulfide, dibromides of the two isomers of ethyl cinnamate are formed, the quantities being a function of the conditions.

Duquenois¹⁶ reports the α,β -dibromo derivative of ethyl *trans*-cinnamate as monoclinic crystals m. 74°-75°. The ethyl *allo*-cinnamate dibromide melts at 28°-30°, according to Michael.¹⁷

Use.—Ethyl cinnamate is used in perfume compositions of floral and oriental type. Occasionally it serves as a fixative for lotions, eaux de Cologne, and lavender waters.

¹ *Liebigs Ann.* **376** (1910), 305.

² *Ber.* **38** (1905), 302.

³ *Roczniki Chem.* **15** (1935), 510. *Chem. Abstracts* **30** (1936), 2933.

⁴ *Liebigs Ann.* **221** (1883), 75.

⁵ *Ber.* **11** (1878), 1220.

⁶ *Liebigs Ann.* **235** (1886), 19.

⁷ *J. Chem. Soc.* **69** (1896), 1228, 1247; **61** (1892), 308.

⁸ *Ibid.* (1936), 405.

⁹ "Organic Syntheses," Coll. Vol. I, 252, John Wiley & Sons, New York (1941).

¹⁰ *Bull. soc. chim.* [5] **5** (1938), 1200.

¹¹ *Ibid.* [4], **53** (1933), 1277.

¹² *Liebigs Ann.* **413** (1917), 264.

¹³ *Z. anorg. Chem.* **101** (1917), 141.

¹⁴ *J. Chem. Soc.* **101** (1912), 414.

¹⁵ *Ber.* **34** (1901), 3663. See also Sudborough and Thompson, *J. Chem. Soc.* **83** (1903), 671; Michael and Smith, *Am. Chem. J.* **39** (1908), 27; James and Sudborough, *J. Chem. Soc.* **95** (1909), 1542; Sudborough and Thomas, *Ibid.* **97** (1910), 719; Bruner and Fischler, *Z. Elektrochemie* **20** (1914), 85; Lespagnol and Bruneel, *J. pharm. chim.* **25** (1937), 454. *Chem. Abstracts* **31** (1937), 6820.

¹⁶ *Bull. soc. chim.* [5], **5** (1938), 1200.

¹⁷ *Ber.* **34** (1901), 3661.

SUGGESTED ADDITIONAL LITERATURE

Karl Morsch, "Action of Ammonia and Amines on Esters of Unsaturated Acids," II. "Action of Ammonia, Methylamine and Diethylamine upon Ethyl Cinnamate," *Monatsh.* **61** (1932), 299.

S. P. Lagerev, "Catalytic Hydrogenation of Ethyl Cinnamate under Pressure," *J. Gen. Chem. U.S.S.R.* **5** (1935), 517. *Chem. Abstracts* **29** (1935), 6887.

Benzyl Cinnamate

 $C_{16}H_{14}O_2$

Mol. Weight 238.27

Cinnamic acid benzyl ester

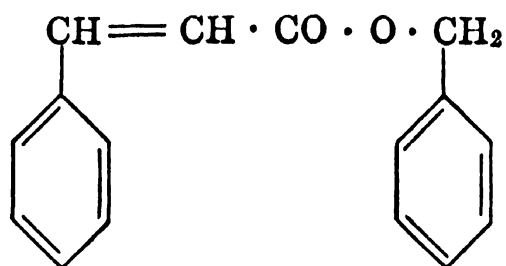

Occurrence.—This ester is an important constituent of oil of styrax, tolu balsam, and Peru balsam. Machado ¹ found benzyl cinnamate to be a constituent (54.3 per cent) of copaiba-jacaré balsam.

Isolation.—By cooling the corresponding fraction to a low temperature, and recrystallization. If no crystals separate on cooling, seeding is advisable.

Identification.—Saponify and identify the constituents as benzyl alcohol and cinnamic acid.

Duquenois ² reported that benzyl dibromohydrocinnamate melts at 95°.

Properties.—Benzyl cinnamate consists of white shiny crystals which decompose at about 350° (Grimaux ³). Occasionally the ester remains liquid for hours even at 0°. The odor of benzyl cinnamate is aromatic, sweet and persistent.

Gildemeister and Hoffmann,⁴ Manta,⁵ and Duquenois ⁶ reported these properties for benzyl cinnamate:

cong. pt.	34.5° ⁴	b ₂₂	204°–205° ⁵ (<i>allo-</i>)
m.	35°–36° ⁵ (<i>trans-</i>)	b ₅	195°–196° ⁴
	34°–35° ⁵ (<i>allo-</i>)	d ₁₅ ²⁵	1.1066 ⁴ (superfused)
	34.5° ⁶ (<i>allo-</i>)		
Sol.	Soluble in 4–6.5 vol. of 90% alcohol at 30°, soluble in 8–11 vol. of 90% alcohol at 20° ⁴		

To prevent decomposition, benzyl cinnamate must be distilled *in vacuo*.

According to Wallerant,⁷ benzyl cinnamate, after fusion, forms first unstable monoclinic crystals and then stable crystal sphaerolites, the double refraction of which is larger than that of the unstable crystals.

Use.—Benzyl cinnamate is used in floral as well as oriental scents. It also serves as a fixative in all kinds of perfume compounds.

¹ *Rev. quim. ind. Rio de Janeiro* **10**, No. 115 (1941), 15, 379. *Chem. Abstracts* **36** (1942), 1735.

² *Bull. soc. chim.* [5], **5** (1938), 1200.

³ *Compt. rend.* **67** (1868), 1051.

⁴ "Die Ätherischen Öle," 3d Ed., Vol. I, 645.

⁵ *Bull. soc. chim.* [4], **53** (1933), 1283, 1285.

⁶ *Ibid.* [5], **5** (1938), 1202.

⁷ *Compt. rend.* **158** (1914), 1474.

SUGGESTED ADDITIONAL LITERATURE

J. Jacobson, "The Disappearance of Keratitis Lesions and Experimental Opacities in the Cornea after Treatment with Benzyl Cinnamate," *Bull. acad. méd.* **110** (1933), 104. *Chem. Abstracts* **28** (1934), 3133.

J. Jacobson, "Benzyl Cinnamate in Treatment of Lesions Caused by Mustard Gas," *Bull. acad. méd.* **123** (1940), 289. *Chem. Zentr.* II (1941), 921. *Chem. Abstracts* **38** (1944), 2120.

Cinnamyl Cinnamate

C₁₈H₁₆O₂

Mol. Weight 264.31

Cinnamic acid cinnamyl ester. "Styracine"

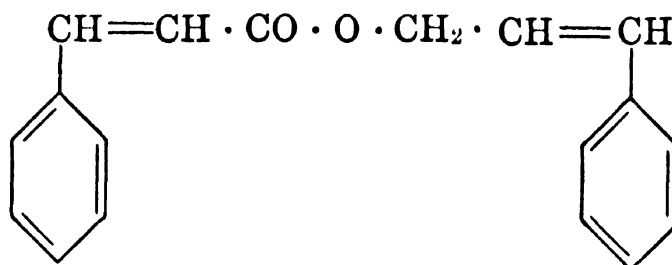

Occurrence.—This ester, commonly known as "Styracine," is an important constituent of styrax; it occurs also in balsam Peru, Honduras balsam, and possibly in a few essential oils.

Isolation.—By cooling the fraction consisting mainly of cinnamyl cinnamate, separation of the crystals and recrystallization.

Identification.—(1) Saponify the ester and identify the components as cinnamic alcohol and cinnamic acid.

(2) On adding bromine to an ethereal solution of cinnamyl cinnamate until the solution is no longer decolorized, the ester, according to Miller,¹ forms a dibromide m. 151° [(β,γ-dibromo-γ-phenylpropyl) cinnamate], which separates after 24 hr. as a white powder. This powder is filtered off, washed with ether, and recrystallized from hot alcohol.

Properties.—Cinnamyl cinnamate is a white crystalline mass, sparingly volatile with steam. It has a faint odor. The solubility in alcohol is low. According to Simon² the ester is soluble in 20 to 22 parts of cold alcohol.

Toel,³ Miller,⁴ and Schröder⁵ reported these properties:

m.	44° ^{3,4}
d ₄	1.1565 ⁵ (solid)

Use.—Because of its mild and lasting odor, cinnamyl cinnamate is used as an odor fixative in perfumes and cosmetics. It blends particularly well with floral scents such as gardenia.

¹ *Liebigs Ann.* **189** (1877), 344; **188** (1877), 202. See also Lespagnol et al., *J. pharm. chim.* **29** (1939), 447; Duquenois, *Bull. soc. chim.* [5], **5** (1938), 1200.

² *Liebigs Ann.* **31** (1839), 273.

³ *Ibid.* **70** (1849), 2.

⁴ *Ibid.* **188** (1877), 200.

⁵ *Ber.* **13** (1880), 1072. Beilstein, "Organische Chemie," Vol. 9 (1926), 585.

D. ESTERS CONTAINING NITROGEN

Methyl Anthranilate

 $C_8H_9O_2N$

Mol. Weight 151.16

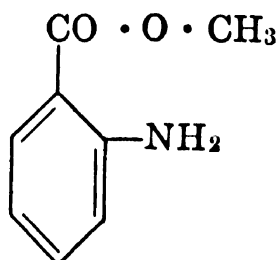
Anthranilic acid methyl ester. *o*-Aminobenzoic acid methyl ester

Occurrence.—Identified first by Walbaum¹ in oil of neroli bigarade, this important basic ester occurs also in other natural flower oils and volatile oils in general—for example, in oil of jasmine, tuberose, jonquil, gardenia, ylang ylang, champaca, *Robinia pseudacacia*, and in the oils distilled from the leaves of the sweet orange, mandarin, bergamot, etc. Power and Chesnut² identified methyl anthranilate in grape juice (*Vitis labrusca*). Small³ recorded the occurrence of traces of methyl anthranilate in oils of orange and lemon.

Isolation.—According to Walbaum,⁴ methyl anthranilate can be isolated from essential oils quite readily by shaking the oil with dilute sulfuric acid. The sulfate thereby formed crystallizes in the cold and may be purified by recrystallization from alcohol. From the sulfate the methyl anthranilate is regenerated by treatment with soda.

Hesse and Zeitschel⁵ developed a method of isolating quantitatively methyl anthranilate from essential oils, but by this procedure methyl anthranilic acid methyl ester, too, is precipitated and determined. In order to differentiate the two esters, Erdmann⁶ suggested another procedure which, like that of Hesse and Zeitschel, is described in Vol. I, Chapter 4, "The Examination and Analysis of Essential Oils, Synthetics, and Isolates," p. 302.

Identification.—Methyl anthranilate can be characterized by the preparation of several derivatives:

(1) The picrate in the form of yellow needles m. 103.5° – 104° , according to Freundler,⁷ 105° – 106° reported by Gildemeister and Hoffmann.⁸

(2) Benzoate m. 99° – 100° , according to Erdmann and Erdmann,⁹ 100° – 102° , by Schimmel & Co.¹⁰

(3) When heated with phenyl mustard oil to 100° – 120° , methyl anthranilate forms quantitatively thiophenylketotetrahydroquinazoline. According to Gildemeister and Hoffmann,¹¹ this compound is readily soluble in sodium hydroxide solution, very sparingly soluble in alcohol. It melts above 300° and sublimes at 160° – 170° .

(4) For the rapid identification of methyl anthranilate in essential oils, 4 drops of the oil are warmed, as suggested by Sabetay,¹² with 12 drops of a mixture from 1 part of acetic anhydride and 2 parts of pyridine for 5 min. on a water bath. The mixture is then diluted, warmed again, and cooled. The residue formed, after crystallization from alcohol, shows a melting point 99° – 100° .

(5) In order to identify methyl anthranilate in fruit juices, Power¹³ suggested coupling it with β -naphthol. Danet¹⁴ recommended a similar rapid method for the

determination of methyl anthranilate in orange flower water. The method depends on the colorimetric determination of methyl ester of anthranilic acid by diazotization and coupling with β -naphthol:

Treat 5 cc. of the water with 0.25 cc. of a 10% solution of sodium nitrite and 0.25 cc. of acetic acid, couple with 0.5 cc. of a saturated solution of β -naphthol in ammonia and dissolve the precipitate in 4 cc. of acetone. A standard solution is prepared by using the methyl ester.

(6) Dermer and King¹⁵ reported the preparation of anthranilic acid N-benzylamide m. 124°–125° from benzylamine and methyl anthranilate.

(7) According to Feigl et al.,¹⁶ the identification of anthranilic acid with hydroxamic acid and ferric chloride is possible with 12 γ quantities, giving a dark violet color.

Quantitative Determination.—Regarding the quantitative determination of methyl anthranilate, see Vol. I, Chapter 4, "The Examination and Analysis of Essential Oils, Synthetics, and Isolates," p. 302.

Properties.—At low temperature methyl anthranilate is a crystalline mass of powerful, lasting and peculiar odor, which in strong dilution resembles orange blossoms and the flavor of certain grape varieties.

Walbaum,¹⁷ who isolated methyl anthranilate from oil of neroli bigarade, and Naves¹⁸ who isolated it from the distillation water of bitter orange blossoms, reported these properties:

cong. pt.	24° ¹⁷	d ₂₅	1.1640 ¹⁸
	23.8° ¹⁸	d ₁₅	1.168 ¹⁷ (undercooled)
m.	24°–25° ¹⁷	n _D ²⁵	1.5802 ¹⁸
b ₁₄	132° ¹⁷	Sol.	Readily soluble in alcohol,
b ₁₃	129°–131° ¹⁸		soluble in water
b ₉	124°–125° ¹⁷ (vac.)		

In concentrated form, especially in alcoholic solution, methyl anthranilate shows a characteristic blue fluorescence. The ester is volatile with steam.

Use.—Methyl anthranilate is used widely but most sparingly in floral compositions, such as orange blossom, jasmine, tuberose, and gardenia. The ester has a tendency to discolor. Methyl anthranilate finds use also in flavor work, especially in synthetic grape.

¹ *J. prakt. Chem.* [2], **59** (1899), 352.

² *J. Am. Chem. Soc.* **43** (1921), 1741. *J. Agr. Research* **23** (1923), 47.

³ *Food* **12** (1943), 179, 210.

⁴ *J. prakt. Chem.* [2], **59** (1899), 352.

⁵ *Ber.* **34** (1901), 296. *J. prakt. Chem.* [2], **64** (1901), 246.

⁶ *Ber.* **35** (1902), 24.

⁷ *Bull. soc. chim.* [3], **31** (1904), 882.

⁸ "Die Ätherischen Öle," 3d Ed., Vol. I, 681.

⁹ *Ber.* **32** (1899), 1216.

¹⁰ *Ber. Schimmel & Co.*, Oct. (1903), 81.

¹¹ "Die Ätherischen Öle," 3d Ed., Vol. I, 681.

¹² *Ann. fals.* **28** (1935), 478. *Chem. Abstracts* **30** (1936), 702.

¹³ *J. Am. Chem. Soc.* **43** (1921), 377.

¹⁴ *J. pharm. chim.* **1** (1941), 434. *Chem. Abstracts* **38** (1944), 2163.

¹⁵ *J. Org. Chem.* **8** (1943), 168.

¹⁶ *Mikrochemie* **15** (1934), 9.

¹⁷ *J. prakt. Chem.* [2], **59** (1899), 352.

¹⁸ *Parfums France* **12** (1934), 64.

SUGGESTED ADDITIONAL LITERATURE

R. H. Clark and E. C. Wagner, "Reactions of Isatoic Anhydride with Primary and Secondary Amines and with Some Amides," *J. Org. Chem.* **9** (1944), 55.

J. F. Meyer and E. C. Wagner, "The Niementowski Reaction; the Use of Methyl Anthranilate or Isatoic Anhydride with Substituted Amides or Amidines . . .," *J. Org. Chem.* **8** (1943), 239.

Arno Müller, "Terpene Chromogenic or Terpenochromic Compounds. The Application of the 'EM' Reaction," *Seifensieder-Ztg.* **68** (1941), 478, 491. *Chem. Abstracts* **37** (1943), 6410.

Dimethyl Anthranilate

$C_9H_{11}O_2N$

Mol. Weight 165.19

N-Methylanthranilic acid methyl ester. *o*-Methylaminobenzoic acid methyl ester

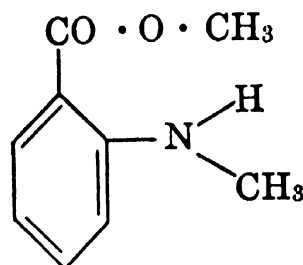

Occurrence.—Dimethyl anthranilate is a most important constituent of mandarin leaf oil; it occurs also in mandarin peel oil, and probably in a few other volatile oils.

Isolation and Quantitative Determination.—The ester can be isolated quantitatively from essential oils by the method of Hesse and Zeitschel,¹ details of which will be found in Vol. I, Chapter 4, "The Examination and Analysis of Essential Oils, Synthetics, and Isolates." In order to determine methyl anthranilic acid methyl ester in the presence of anthranilic acid methyl ester, the total ester content is first assayed by the method of Hesse and Zeitschel, and in another test the content of anthranilic acid methyl ester by the method of Erdmann.² The difference then indicates the percentage of methyl anthranilic acid methyl ester (cf. Vol. I of this work, p. 303).

Identification.—(1) Dimethyl anthranilate is characterized by the determination of its properties and by hydrolysis to methyl anthranilic acid which forms white prismatic crystals m. 179°. In dilution this acid shows blue fluorescence.

(2) Dermer and King³ suggested the direct preparation of anthranilic acid N-benzylamide m. 124°–125° by the action of benzylamine on the methyl ester.

(3) According to Feigl et al.,⁴ the identification of anthranilic acid with hydroxamic acid and ferric chloride is possible for as little as 12 γ . This complex has a violet color.

Properties.—The odor of dimethyl anthranilate is similar to, but somewhat softer than that of methyl anthranilate.

Walbaum,⁵ and Schmidt⁶ reported these properties for dimethyl anthranilate isolated from mandarin leaf oil:

m.	18.5°–19.5° ⁵	α_D	$\pm 0^\circ$ ⁵
b ₁₃	130°–131° ⁵	n _D ^{12.3}	1.58395 ⁶
d ₁₅	1.120 ⁵		
d ₄ ^{12.5}	1.1348 ⁶		

The ester is soluble in alcohol, ether or chloroform. Soluble in 10 volumes of 70 per cent alcohol, in 3 volumes of 80 per cent alcohol. Dimethyl anthranilate shows a strong blue fluorescence, also in dilution.

Use.—Similar to that of methyl anthranilate.

¹ *Ber.* **34** (1901), 296. *J. prakt. Chem.* [2], **64** (1901), 246.

² *Ber.* **35** (1902), 24.

³ *J. Org. Chem.* **8** (1943), 168.

⁴ *Mikrochemie* **15** (1934), 9.

⁵ *J. prakt. Chem.* [2], **62** (1900), 136.

⁶ *Ber.* **38** (1905), 203.

Damascenine

C₁₀H₁₃O₃N

Mol. Weight 195.21

3-Methoxy-N-methylanthranilic acid methyl ester. 3-Methoxy-2-methylaminobenzoic acid methyl ester

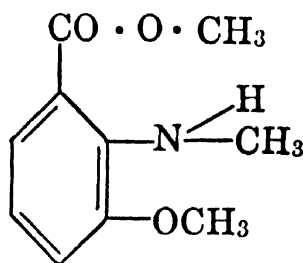

Occurrence.—Damascenine, an alkaloid, was first observed by Schneider¹ in the seeds of *Nigella damascena*. Pommerehne,² and Keller³ isolated damascenine also from the seeds of *Nigella aristata*. The chemical constitution of damascenine was first elucidated by Ewins.⁴

Isolation.—Pommerehne⁵ treated the whole seeds with diluted hydrochloric acid, then saturated the solute with sodium carbonate and extracted the alkaloid with petroleum ether.

Identification.—(1) Ewins⁶ prepared damascenine picrate by precipitating the picrate from an aqueous solution of a salt of the base with a saturated solution of picric acid in water. The picrate crystallizes in yellow rhombic plates m. 158°–159° and, unlike damascenic acid picrate, melts without formation of a blue liquid.

(2) According to Schneider,⁷ damascenine, when treated with sulfuric acid, forms a salt (C₁₀H₁₃O₃N)·H₂SO₄, needles m. 168°–170°.

(3) Damascenine nitrate, recrystallized from water, melts at 98° and exhibits a blue color at 180°, according to Schneider; ⁸ m. 94°–95°, according to Ewins.⁹

(4) The hydroiodide, recrystallized from water, melts at 140° ; it is formed on boiling damascenine with methyl iodide and methyl alcohol under reflux, according to Keller.¹⁰

Properties.—According to Ewins,¹¹ and Kaufmann and Rothlin,¹² damascenine has these properties:

m.	24° – 26° ¹¹ (<i>natural</i>)
	23° – 24° ¹¹ (<i>synthetic</i>)
b ₇₅₀	270° ¹¹ (<i>natural</i>)
b ₁₇	156° – 157° ¹¹ (<i>synthetic</i>)
b ₁₅	154° ¹¹
b ₁₀	147° – 148° ¹²

On boiling with hydrochloric acid, subsequent saponification in alcoholic potassium hydroxide and recrystallization from water, damascenine forms damascenic acid containing 3 mols of water of crystallization, m. 76° – 77° , according to Pommerehne.¹³

Damascenine hydrochloride (anhydrous) is prepared by precipitating it from the dry ethereal solution of the base and by careful addition of an alcoholic solution of hydrogen chloride; m. 156° slender prisms.

According to Ewins,¹⁴ the anhydrous hydrochloride is deliquescent and, when crystallized from 80 per cent alcoholic solution, forms $C_{10}H_{13}O_3N \cdot HCl \cdot H_2O$ which separates with 1 mol of water of crystallization and melts at 121° – 122° . According to Keller,¹⁵ this substance loses 1 mol of water *in vacuo*. The same author found that damascenine, on treatment with sodium nitrite in hydrochloric acid solution, yields a crystalline mass which, recrystallized from dilute alcohol, melts at 72° but softens at 60° .

Damascenine forms salts with the usual alkaloid reagents such as platinum, gold, or mercuric chloride.

Use.—The literature does not reveal whether this product is actually used in our industries. It may be part of some perfume specialties, but under the name damascenine this compound is not found on the market.

¹ *Pharm. Zentr.* **31** (1890), 173, 191. *Ber. Schimmel & Co.*, April (1908), 75.

² *Arch. Pharm.* **238** (1900), 546; Keller, *ibid.* **242** (1904), 295.

³ *Ibid.* **246** (1908), 1.

⁴ *J. Chem. Soc.* **101** (1912), 544.

⁵ *Arch. Pharm.* **238** (1900), 546; Keller, *ibid.* **242** (1904), 295.

⁶ *J. Chem. Soc.* **101** (1912), 551.

⁷ *Pharm. Zentr.* **31** (1890), 193.

⁸ *Ibid.*

⁹ *J. Chem. Soc.* **101** (1912), 546.

¹⁰ *Arch. Pharm.* **246** (1908), 10.

¹¹ *J. Chem. Soc.* **101** (1912), 546, 547.

¹² *Ber.* **49** (1916), 583.

¹³ *Arch. Pharm.* **239** (1901), 35.

¹⁴ *J. Chem. Soc.* **101** (1912), 551.

¹⁵ *Arch. Pharm.* **246** (1908), 11; **263** (1925), 482.

SUGGESTED ADDITIONAL LITERATURE

V. M. Rodionov and A. M. Fedorova, "Homologs of Damascenine Alkaloid," *Bull. acad. sci. U.S.S.R., Classe sci., math. nat. Sér. chim.* (1937), 501. *Chem. Abstracts* **31** (1937), 7864.

Léo Marion, "The Alkaloids of the Indole Series," *Rev. trimestr. can.* **27** (1941), 392. *Chem. Abstracts* **36** (1942), 1611.

IX. LACTONES, COUMARINS, AND COUMARONES

Introduction.—Lactones are quite widely distributed in nature. The most important members of this class occurring in essential oils are the coumarins and coumarone derivatives, many of which have been isolated from aromatic plants, identified, and synthesized. For our purpose we may subdivide these compounds into three groups:

(1) The coumarins proper and their derivatives which may be said to be derived from *o*-hydroxy cinnamic acid, or viewed theoretically, from the fusion of one benzene nucleus with one 1,2-pyrone (also called 1,2-coumarin) ring.

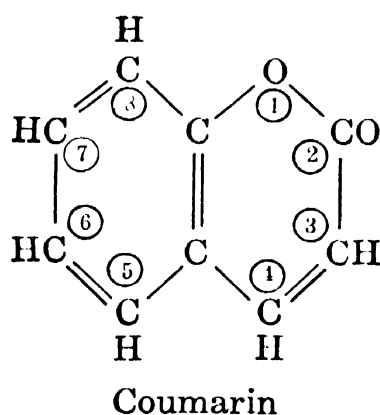

Typical representatives of this benzo-1,2-pyrone group are coumarin, umbelliferone, methyl umbelliferone, ostruthin, auraptene, osthol, limettin, etc.

(2) The coumarones which, viewed theoretically, originate by the fusion of one benzene nucleus with one furan ring.

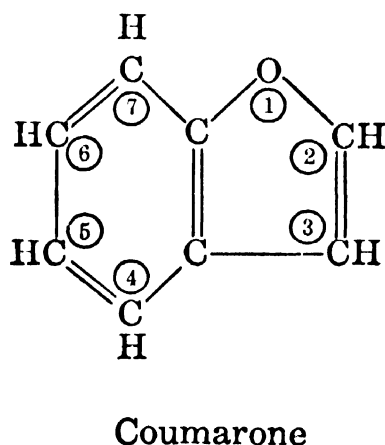

Coumarone itself does not occur in essential oils, but many derivatives of coumarone have been found in the plant kingdom.

(3) The compounds that may be viewed as a combination of one coumarin ring with one furan ring—therefore, the term furanocoumarins or furocoumarins. Two types of fusion between the furan ring and the coumarin ring are possible, viz.:

(a) the linear type (fusion between the 6 and 7 position of the coumarin molecule); and

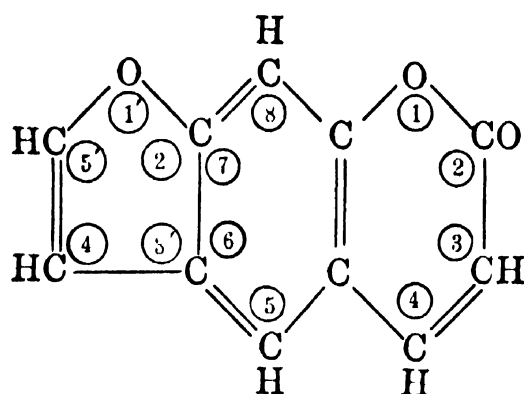

Psoralene
(linear type)

Representatives of the linear type are psoralene, bergaptol, bergaptene, xanthotoxin, imperatorin, isoimperatorin, and isopimpinellin.

(b) the angular type (fusion between the 7 and 8, or 5 and 6 position of the coumarin molecule).

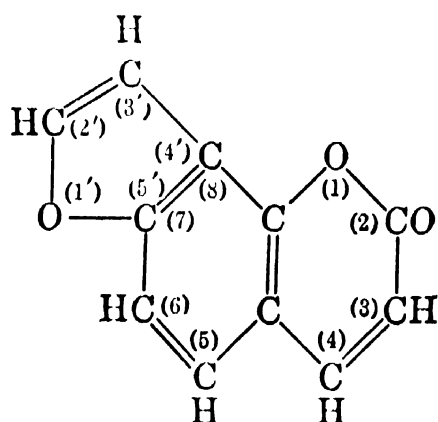

Angelicin
(angular type)

Representatives of the angular type are angelicin and pimpinellin.

These coumarin and coumarone derivatives occur either in free or combined state.

Coumarin itself is widely distributed in nature; it has been found in more than sixty plants belonging to about twenty-four natural orders. Coumarins often occur in plants as glycosides. Melilotoside is a glycoside of hydrocoumarinic acid. The presence of coumarin is indicated whenever *o*-coumaric acid (*trans-o*-hydroxy cinnamic acid or *trans-o*-coumarinic acid) can be identified in an essential oil or in a plant extract. By fission of the pyrone ring in the coumarin molecule under the influence of alkalies, unstable *o*-coumarinic acid (*cis-o*-hydroxy cinnamic acid) is first formed but readily isomerizes into the stable *o*-coumaric acid (*trans-o*-hydroxy cinnamic acid). On the other hand, the stable *trans*- isomer can be changed into the unstable *cis*- form by

the action of light or on treatment with acids. However, the experimental realization of these isomeric changes is in many cases beset with difficulties. The *cis*-form (coumarinic acid) exists in the form of salts.

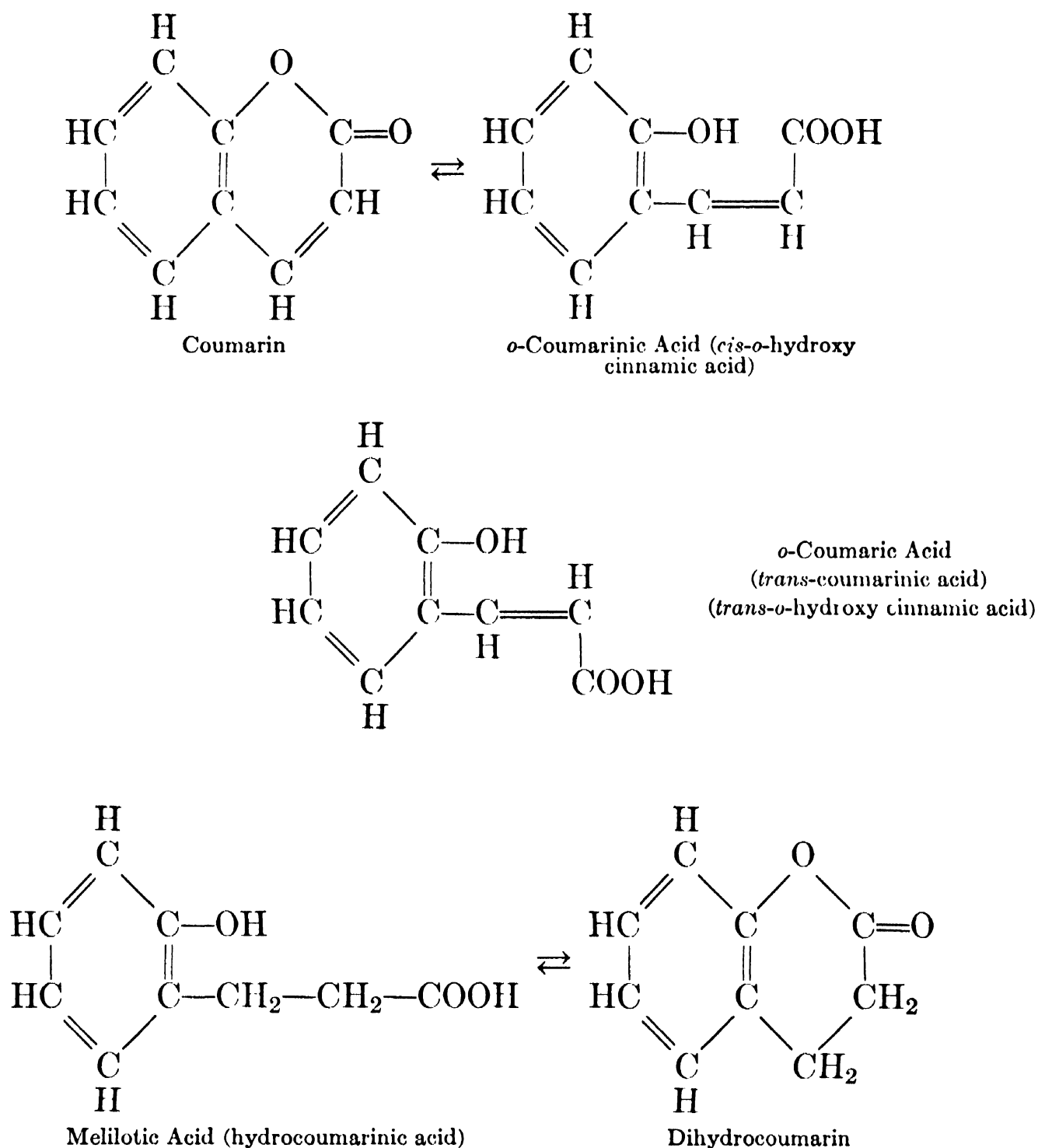

A large amount of work has been done on the reactivity of the double bonds in coumarins. The double bond between carbon atoms 3 and 4 in the coumarin nucleus is highly reactive. It adds bromine, hydrogen cyanide, and sodium bisulfite with great facility. Perkin¹ studied the addition of bromine, and Dey and Row,² and Dodge³ reported on the reaction of sodium bisulfite with coumarins.

Most of the coumarins, coumarone derivatives, and some lactones in general have high boiling points and are only sparingly, if at all, volatile with steam. They are, therefore, found mainly in extracted oils, especially in ex-

pressed citrus peel oils as, for instance, bergaptene in oil of bergamot, or limettin in oil of lemon and lime. Certain lactones occur in the high boiling fractions of distilled oils—for example, ambrettolide in oil of ambrette seed and angelicin in oil of angelica root. These compounds contribute greatly to the odor value of these oils and, therefore, it is necessary to distill the corresponding plant material carefully, that is, sufficiently long so that all the high boiling constituents are carried over by the steam.

Of the numerous lactones occurring in nature, only those identified in essential oils and only the more important ones will be mentioned in these pages.

Isolation.—Sethna and Shah ⁴ suggested the following method for the isolation of coumarins and coumarin derivatives from plant extracts:

The extract is treated with a dilute aqueous alkali solution (0.5%) to remove any acids and phenolic substances that may be present. A simple coumarin having no interfering group in the molecule and not in combination with glucose as glucoside can then be isolated on treatment with a 5% aqueous-alcoholic solution of potassium hydroxide. By this treatment the coumarins are transformed into the potassium salts of the corresponding coumarinic acids as the lactone ring opens (see "Introduction"). Other reactions, too, occur simultaneously—for example, saponification of any fatty acid esters present. The mixture is then diluted with water and extracted with ether, whereby other substances (if any) are removed. The alkaline layer is subsequently acidified whereby the acidic substances (if any) and coumarins are liberated. This mixture is taken up with an excess of ether and treated dropwise with dilute aqueous alkali; the acids dissolve and the coumarins remain behind. By repeating this process the acids along with a fraction of the coumarin are removed. Further separation can be effected by vacuum distillation and/or sublimation. The coumarin should finally be purified by crystallization, chromatographic analysis, or other suitable methods.

If the original plant material contained any hydroxycoumarins, they are carried down in the aqueous portion by initial treatment with aqueous alkali. That fraction is worked up; i.e., acidified, extracted with ether, and separated from other fatty substances by extraction with petroleum ether. The material is then distilled in a high vacuum and further purified by crystallization. To ascertain the presence of hydroxycoumarins, a portion of the liquid after acidifying should be treated with diazomethane and then subjected to the treatment described above. If a methoxycoumarin is found to be present, a hydroxycoumarin was present in the original material. It may be mentioned here that prolonged treatment with alkali should be avoided, as it causes a change of hydroxycoumarin into coumaric acid to a small extent.

Esters of hydroxycoumarins, if present, will be found together with nonhydroxylic coumarins, but due to hydrolysis they may suffer in the course of separation. Hydroxycoumarins will be produced and separated along with them; they should be worked up as described above.

Coumarin glucosides may be detected as follows: free the soluble fraction, after the treatment with alcoholic alkali, from impurities by extraction with ether; then decompose the glucosides by the action of dilute sulfuric acid, and test the resulting aglucone for coumarin.

Detection.—Regarding the detection of natural coumarins in drugs the reader is referred to the paper by Casparis and Manella.⁵

Kanevskaja and Fedorova⁶ suggested a method for the quantitative determination of simple coumarins, which is of possible interest in the separation of coumarins.

Physiological Effects.—It might be of interest to add a few words concerning the physiological effects of coumarins and coumarin derivatives on animals and on man. For details the reader is referred to von Werder's collective bibliography on the subject.⁷ On human beings, coumarin has a slightly toxic effect. The first dose to the extent of 4 g. produces the symptoms of illness and weakness. A dose of approximately 5 g. kills a sheep. The fatal dose for horses and cattle is about 40 g. The hydroxycoumarins have been found less effective, although toxicity increases considerably on methylation. Pimpinellin, peucedanin, and ostruthin possess only little toxicity on mice, rats, and guinea pigs. Natural coumarins are highly effective substances on fish in spite of the low concentration of solutions employed, due to the fact that most of these substances are sparingly soluble in water. Coumarin was lethal to fishes in as low a concentration as 1 g. in 6800 cc. of water. Some furanocoumarins are highly toxic to fish.

¹ *J. Chem. Soc.* **23** (1870), 368.

² *Ibid.* **125** (1924), 554.

³ *J. Am. Chem. Soc.* **38** (1916), 446; **52** (1930), 1724.

⁴ *Chem. Rev.* **36** (1945), 1.

⁵ *Hundert Jahre Schweiz. Apoth.-Ver. (Centenaire soc. suisse pharm.)* (1943), 347. *Chem. Abstracts* **38** (1944), 1841.

⁶ *Z. anal. Chem.* **93** (1933), 176.

⁷ *Merck's Jahresberichte* **50** (1936), 88.

SUGGESTED ADDITIONAL LITERATURE

R. W. Moncrieff, "The Nature of Lactones," *Am. Perfumer* **48**, No. 11 (1946), 47.

Rolf Brodersen and Anders Kjaer, "The Antibacterial Action and Toxicity of Some Unsaturated Lactones," *Acta Pharmacol. et Toxicol.* **2** (1946), 109 (in English). *Chem. Abstracts* **41** (1947), 2121.

G. A. Richardson, M. S. El-Rafey and M. L. Long (Univ. of California, Coll. of Agr., Davis), "Flavones and Flavone Derivatives as Antioxidants," *J. Dairy Sci.* **30** (1947), 397. *Chem. Abstracts* **41** (1947), 6637.

M. Stoll, "Formation of 15-Pentadecanolide from 15-Bromopentadecanoic Acid," *Helv. Chim. Acta* **30** (1947), 1393.

Coumarin

 $C_9H_6O_2$

Mol. Weight 146.14

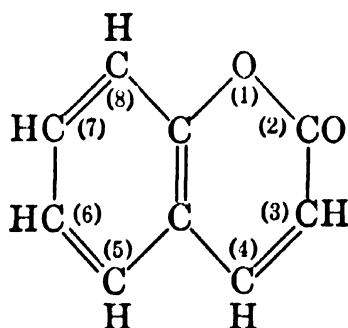
Lactone of *o*-hydroxycinnamic acid

Occurrence.—Coumarin is widely distributed in plants. However, it seems quite certain that in many cases, especially when the plants are odorless, this compound occurs in the form of a complex from which the lactone is liberated on withering of the plants by enzyme action, or by special treatment. This would explain the typical coumarin odor which may develop on drying foliage in the sun (action of ultraviolet light?).

Coumarin is the odoriferous principle of tonka beans, melilot and woodruff (*Asperula odorata*). Coumarin has been identified in oil of lavender, cassia, Peru balsam and in many other essential oils, and in extracts of numerous aromatic plants.

Isolation.—When boiled for a short time with mild alkali solutions, coumarin yields salts of coumarinic acid from which coumarin can readily be regenerated and precipitated on treatment with hydrochloric acid, even with carbon dioxide.

Shumeiko¹ recommended the following method for the isolation and purification of coumarin when strongly admixed with contaminating neutral organic substances:

Treat the crude product with an equal weight of 60–65% sulfuric acid, mix for 30 min., remove the lower layer and extract the upper layer with half its weight of the same acid. Repeat three to four times. Heat the combined extract to 50°–60°, add formalin until its odor does not disappear, filter, and dilute with hot water to 30% sulfuric acid. Wash the upper layer with warm water (70°–75°) to neutral reaction to Congo red. Dry in vacuo and distill at 3–5 mm. Recrystallize from alcohol. Cool the lower layer and recrystallize from alcohol.

Identification.—Coumarin sublimes unchanged and is easily identified by melting point determination. The following reactions and derivatives have been suggested:

(1) On addition of iodine test solution ($\frac{N}{10}$ iodine), a saturated aqueous solution of coumarin forms a precipitate which at first is brown and flocculent, but on shaking coalesces, forming thereby a dark green curdy mass and leaving a clear supernatant liquid (distinction from vanillin).²

(2) According to Dodge,³ and Dey and Row,⁴ coumarin is soluble in solutions of sodium sulfite or sodium bisulfite, forming thereby sodium hydrocoumarin sulfonate $C_9H_6O \cdot NaHSO_3 \cdot H_2O$ which, on treatment with more than 2 mols of 50% alkali, is converted to *o*-coumaric acid $HO \cdot C_6H_4 \cdot CH=CH \cdot COOH$, m. 208°, as obtained by acidification. Also, on heating with concentrated alkali or alcoholic potassium hydroxide, coumarin yields salts of coumaric acid. On the other hand, short boiling with mild alkalies gives solutions of salts of the isomeric coumarinic acid from which cou-

marin can readily be regenerated even by treatment with carbon dioxide or hydrochloric acid. (See "Isolation.")

According to Smol'yaninova,⁵ this procedure of forming bisulfite compounds offers the only method of isolating and identifying coumarin in the presence of the 3-methyl isomer.

(3) Although not of high yield, a crystalline adduct m. 181°–181.5° is obtainable by autoclaving 2,3-dimethyl-1,3-butadiene and coumarin at 260° in xylene, according to Adams et al.⁶

Properties.—Coumarin ordinarily crystallizes in the form of colorless, shiny leaflets or of rhombic prisms. However, Lindpaintner⁷ has reported this substance as polymorphic existing in three forms. It sublimes without decomposition and is readily volatile with steam. The odor is pleasant, pronounced and characteristic of tonka beans, the taste bitter. The following properties have been reported by von Rechenberg,⁸ and the Odorgraphia Committee (Lauffer):⁹

m.	68° ⁹
b.	301° ⁹ (total immersion)
b _{750.2}	301.1° ⁸
b ₂₀	170.4° ⁸
b ₁₀	153.9° ⁸
b ₅	138.5° ⁸

One g. of coumarin is soluble in 400 cc. of cold water, or in about 50 cc. of hot water. It is freely soluble in ether, chloroform, in fixed or volatile oils.

The Odorgraphia Committee Report¹⁰ lists these solubilities in alcohol:

1 g. of coumarin dissolves in	}	16.6 cc. 50% alcohol at 25° C.
		30.0 cc. 50% alcohol at 15° C.
		5.7 cc. 70% alcohol at 25° C.
		12.0 cc. 70% alcohol at 15° C.

According to de Jong,¹¹ coumarin as solid or in solution, on exposure to sunlight, changes to a dimer m. 262°.

Use.—Coumarin is used widely in perfumes and cosmetics, and for the scenting of soaps in new mown hay, lavender, fougère, and chypre blends. Coumarin blends well with vanillin and heliotropin. Another wide use of coumarin is in the flavoring of baked goods, all kinds of confectionery, candies, and tobacco. Coumarin also serves as an important adjunct in synthetic vanilla flavors.

¹ *J. Applied Chem. U.S.S.R.* **13** (1940), 1204. *Chem. Abstracts* **35** (1941), 2133.

² "National Formulary," Eighth Ed. (1946), 175.

³ *J. Am. Chem. Soc.* **38** (1916), 446; **52** (1930), 1724.

⁴ *J. Chem. Soc.* **125** (1924), 554.

- ⁵ *Sintezy Dushistykh Veshchestv, Sbornik Stateĭ* (1939), 162. *Khim. Referat. Zhur.* No. 4 (1940), 115. *Chem. Abstracts* **36** (1942), 3795.
- ⁶ *J. Am. Chem. Soc.* **65** (1943), 356.
- ⁷ *Mikrochemie* **27** (1939), 21.
- ⁸ "Einfache und fraktionierte Destillation," (1923), 304.
- ⁹ *Ind. Eng. Chem., News Ed.* **11** (1933), 114.
- ¹⁰ *Ibid.*
- ¹¹ *Rec. trav. chim.* **43** (1924), 320. See also von Wessely and Plaichinger, *Ber.* **75B** (1942), 971.

SUGGESTED ADDITIONAL LITERATURE

John B. Wilson, "Determination of Coumarin," *J. Assocn. Official Agr. Chem.* **22** (1939), 378.

Ignaz Herold, "Coumarin," *Seifensieder-Ztg.* **66** (1939), 162, 191. (A Review)

D. T. Englis and Donald J. Hanahan, "Determination of Vanillin and Coumarin in Flavoring Extracts," *Ind. Eng. Chem., Anal. Ed.* **16** (1944), 505.

Miloš Černý, "The Determination of Coumarin in Plant Substances," *Chem. Obzor* **18** (1943), 149. *Chem. Zentr. I* (1944), 40. *Chem. Abstracts* **39** (1945), 3328.

P. Casparis and E. Manella, "Coumarins in Drugs. The Detection of Natural Coumarin," *Pharm. Acta Helv.* **18** (1943), 714. *J. Am. Pharm. Assocn.* (Abstracts) **35**, No. 6 (1946), 190.

Umbelliferone

C₉H₆O₃

Mol. Weight 162.14

7-Hydroxycoumarin

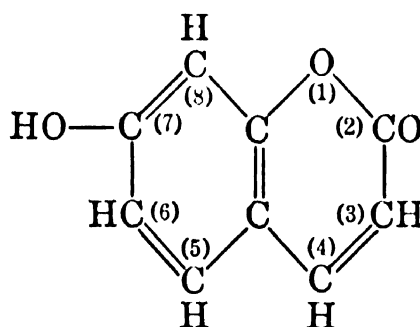

Occurrence.—Umbelliferone occurs in the free state in the bark of the spurge-laurel (*Daphne mezereum*). It is also obtained by dry distillation of the resins from several *Umbelliferae* species.

Markley, Nelson and Sherman¹ identified umbelliferone in the waxy distillation residue of Florida grapefruit oil.

Isolation.—By the usual methods of isolating coumarin derivatives.

Identification.—By melting point determination.

Meerwein, Büchner and van Emster² reported on the reaction of umbelliferone with *p*-chlorobenzenediazonium chloride yielding the 3-*p*-chlorophenyl derivative m. 280°–282°; if an excess of sodium carbonate is added to the sodium salt derivative of umbelliferone, there results a chocolate azo-dye C₁₅H₁₉O₃N₂Cl.

Casparis and Manella³ found that natural coumarins, including umbelliferone, ostruthin, bergaptene, imperatorin and others, can be detected in drugs by the fluorescence exhibited in diffused light and in ultraviolet light by various solutions of these natural coumarins and coumarin derivatives.

Properties.—Umbelliferone melts at 224°. In alkali solutions umbelliferones (7-hydroxycoumarins) show fluorescence. Goto ⁴ found the fluorescence indicator of umbelliferones to be effective at pH 4. According to Chakravarti and Mukerjee,⁵ 5-hydroxycoumarins show no fluorescence whatsoever in alkali solutions. Volmar ⁶ reported on umbelliferone as a very sensitive fluorescent indicator for fixed alkalies, useful for titrating the acidity of certain highly colored substances such as wines, etc.

When hydrolized at 70°, umbelliferone, according to Limaye and Kulkarni,⁷ yields 2,4-dihydroxycinnamic acid m. 217°.

On heating umbelliferone in methanol-potassium hydroxide solution with methyl iodide, umbelliferone methyl ether (herniarin) is obtained. According to Fischer,⁸ crystalline herniarin on exposure to light, especially ultraviolet light, forms hydrodiherniarin m. 207°–208° (stable form).

Use.—Natural umbelliferone, as such, is not used in the perfume or flavor industries.

¹ *J. Biol. Chem.* **118** (1937), 433.

² *J. prakt. Chem.* [2], **152** (1939), 256.

³ *Hundert Jahre Schweiz. Apoth.-Ver. (Centenaire soc. suisse pharm.)* (1943), 347. *Chem. Abstracts* **38** (1944), 1841.

⁴ *J. Chem. Soc. Japan* **59** (1938), 199. *Chem. Abstracts* **32** (1938), 3721, 4458.

⁵ *J. Indian Chem. Soc.* **14** (1937), 725. *Chem. Abstracts* **32** (1938), 4156.

⁶ *Documentation sci.* **5** (1936), 33; *Chimie & industrie* **37**, 446. *Chem. Abstracts* **31** (1937), 4919.

⁷ *Rasayanam* **1** (1941), 208. *Chem. Abstracts* **36** (1942), 1033.

⁸ *Arch. Pharm.* **279** (1941), 306. *Chem. Zentr.* I (1942), 2541. *Chem. Abstracts* **37** (1943), 3748.

Umbelliferone Methyl Ether

C₁₀H₈O₃

Mol. Weight 176.16

Methylumbelliferone. 7-Methoxycoumarin. Herniarin. Ayapanin

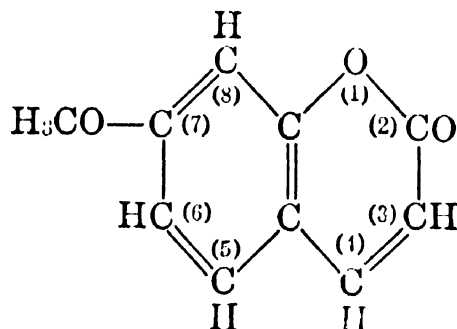

Occurrence.—Umbelliferone methyl ether occurs in the oil of German chamomile (*Matricaria chamomilla* L.). Kaufmann and Kjelsberg,¹ and Pfau ² identified umbelliferone methyl ether in the oil extracted from French lavender, the concrete oil containing 2.5 per cent and the absolute oil 4.5 per cent of umbelliferone methyl ether. On standing, the concretes and absolutes of lavender frequently separate methyl umbelliferone as a crystalline deposit. Ellmer ³ found that a concrete of lavender made by extracting lav-

ender with benzene contained about 5 per cent of methyl umbelliferone. According to the same author, 1000 kg. of lavender plants contain at least 60 g. of umbelliferone methyl ether.

Isolation.—Ellmer ⁴ suggested the following method of isolating coumarin and umbelliferone methyl ether from essential oils.

Dissolve the oil in the same quantity of methyl alcohol and titrate very quickly to red with a normal alkali solution and phenolphthalein as indicator, in order to separate the free acids. Shake the solution immediately with ether and ice water, separate the ether layer, and extract it three times for 1 hr. with concentrated barium hydroxide solution. Regenerate the lactones by treating the united barium hydroxide solutions with dilute hydrochloric acid. Extract with ether and recover the lactones by removing the ether through distillation or evaporation.

Identification.—By melting point determination. On heating, umbelliferone methyl ether develops an odor of coumarin. In concentrated sulfuric acid it shows blue fluorescence. On bromination umbelliferone methyl ether (herniarin) yields dibromoherniarin m. 157°–158° (from alcohol), according to Fischer.⁵ The *meta*-stable form melts at 146°–147°.

Properties.—Pure umbelliferone methyl ether is odorless. It melts at 117°–117.5°, according to Pfau.⁶

Fischer ⁷ found that herniarin when microsublimed from *Herba herniariae* melts at 117°–118°.

Dey, Rao and Seshadri ⁸ reported on the fundamental difference between the behavior of the *trans*-acids of the coumarinic acid series and their esters under the action of heat. The acids decompose into the corresponding styrenes and carbon dioxide, whereas the esters eliminate alcohol to form the original pyrones. The action of sunlight differs from that of heat; sunlight converts both the esters and the acids into the corresponding coumarins, the esters undergoing inversion more readily than the acids. The table of percentage conversion of the *trans*-esters into the coumarins when heated shows that the effects of substituents are similar to those found in the photochemical inversion.

According to Fischer,⁹ herniarin undergoes photodimerization, the *meta*-stable form melting at 181°, the stable form at 207°–208°.

Von Wessely and Plaichinger ¹⁰ reported on photodimers of coumarins and furanocoumarins, including herniarin.

Bose and Sen ¹¹ experimented with ayapanin from the aromatic herb *Eupatorium ayapana* as a new hemostatic agent.

Use.—Umbelliferone methyl ether, as such, is not used in the perfume and flavor industries.

¹ *Parfumerie Moderne* **20** (1927), 198.

² *Perfumery Essential Oil Record* **18** (1927), 205.

³ *Riechstoff Ind.* (1927), 206.

⁴ *Ibid.*

⁵ *Arch. Pharm.* **279** (1941), 306. *Chem. Abstracts* **37** (1943), 3748.

⁶ *Perfumery Essential Oil Record* **18** (1927), 205.

⁷ *Arch. Pharm.* **279** (1941), 306. *Chem. Abstracts* **37** (1943), 3748.

⁸ *J. Indian Chem. Soc.* **11** (1934), 743. *Chem. Abstracts* **29** (1935), 2525.

⁹ *Arch. Pharm.* **279** (1941), 306. *Chem. Abstracts* **37** (1943), 3748.

¹⁰ *Ber.* **75B** (1942), 971.

¹¹ *Ann. Biochem. Exptl. Med.* **1**, No. 4 (1941), 311. *Chem. Abstracts* **37** (1943), 3835.

Eugenine

$C_{11}H_{10}O_4$

Mol. Weight 206.19

Occurrence.—Meijer¹ reported this coumarin derivative in the oil extracted (with petroleum ether) from the dried buds (cloves) of the tree *Eugenia caryophyllata* Thunb. growing wild in the Moluccas. Strangely, the oil from cloves of the wild growing tree does not contain any eugenol.

Meijer² expressed the opinion that eugenine is 4-methyl-5-hydroxy-7-methoxy coumarin. More recently, however, Schmid³ synthesized 4-methyl-5-hydroxy-7-methoxycoumarin and 4-methyl-5-methoxy-7-hydroxycoumarin. Studying the melting points of these two isomers and the melting points of their acetates, Schmid arrived at the conclusion that neither isomer is identical with the natural eugenine. It has remained for Meijer,⁴ however, to show definitely that eugenine is 2-methyl-5-hydroxy-7-methoxychromone.

Isolation.—By distillation *in* (high) *vacuo* and recrystallization.

Identification.—By melting point determination.

Properties.—White crystals m. 119°–120°; odorless. The acetate melts at 150°–151°.

Use.—Eugenine, as such, is not used in our industries.

¹ *Rec. trav. chim.* **65** (1946), 843.

² *Ibid.*

³ *Helv. Chim. Acta* **30** (1947), 1661.

⁴ *Ibid.* **31** (1948), 1603.

Limettin

$C_{11}H_{10}O_4$

Mol. Weight 206.19

Citroptene. Citraptene. 5,7-Dimethoxycoumarin

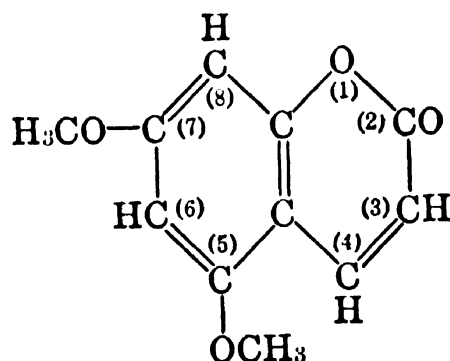

Occurrence.—Tilden and Beck,¹ Tilden and Burrows,² Burgess,³ Späth and Kainrath,⁴ and Caldwell and Jones⁵ established the presence of this dimethoxycoumarin in expressed oil of bergamot, lemon, and lime.

Isolation.—By the usual method of isolating coumarins and coumarin derivatives from plant extracts or essential oils. According to Dodge,⁶ limettin may be purified by conversion into sodium dihydrolimettin sulfonate, $C_{11}H_{11}O_4SO_3Na$ with $4H_2O$, which dissolves in 6 volumes of water and from which limettin is regenerated by treatment with dilute alkali solutions.

Caldwell and Jones⁷ separated pure limettin from the deposited material of expressed lime oil by chromatographic analysis (see "7-Methoxy-5-Geranoxycoumarin").

Identification.—By melting point determination. Refer to chemical properties as described in the following section.

Properties.—Repeatedly recrystallized from acetone or methyl alcohol or dilute ethereal alcohol and treated with animal charcoal (chromatographic separation), limettin forms shiny colorless needles m. 146° – 147° , according to Späth and Kainrath,⁸ and Schmidt;⁹ m. 147.5° (Tilden,¹⁰ and Heyes and Robertson¹¹). Limettin is sparingly soluble in water or petroleum ether but readily soluble in hot alcohol, benzene, or glacial acetic acid. The diluted solutions show a violet fluorescence. Schmidt¹² found that limettin is insoluble in cold dilute potassium hydroxide.

According to Tilden,¹³ limettin partly decomposes on dry distillation at 200° .

Dodge¹⁴ observed that the limettin separated from expressed lime oil and purified by recrystallization from acetone is often accompanied by yellow rosettes or nodules. These were shown to consist of isopimpinellin $C_{13}H_{10}O_5$, m. 149.8° (corr.) which previously had been isolated by von Wessely and Kallab¹⁵ from *Pimpinella saxifraga*.

Tilden,¹⁶ and Tilden and Burrows¹⁷ investigated the mono-, di-, and trichlorocitroptenes: 6- or 8-chlorocitroptene is formed by passing chlorine through a cold solution of citroptene in glacial acetic acid until the precipitate is just dissolved; needles m. 242° (from glacial acetic acid).

3,6- or 3,8-Dichlorocitroptene is formed in the same way but in the presence of a small amount of iodine. It melts at 275° .

3,6,8-Trichlorocitroptene is formed on passing a current of chlorine into a solution of citroptene in glacial acetic acid until completely saturated. Needles m. 188.5° (from methyl alcohol).¹⁷

By introducing a solution of citroptene into a supersaturated solution of bromine in benzene or toluene or glacial acetic acid, dibromocitroptene is formed. According to Tilden,¹⁸ and Tilden and Beck,¹⁹ the leaflets or prisms (from chloroform) melt at 257° (with decomposition).

On boiling with dilute potassium hydroxide (Schmidt²⁰), or with alcoholic sodium ethylate (Tilden and Burrows²¹), citroptene yields the dimethoxycoumaric acid.

When treated with warm diluted nitric acid, citroptene yields nitrocitroptene (Tilden²²).

Schmidt²³ succeeded in synthesizing limettin.

Use.—Limettin, as such, is not used in the perfume or flavor industries.

- ¹ *J. Chem. Soc.* **57** (1890), 323. Tilden, *ibid.* **61** (1892), 344.
² *Ibid.* **81** (1902), 508. ¹³ *J. Chem. Soc.* **61** (1892), 344.
³ *Chem. Ztg.* **25** (1901), 602. ¹⁴ *Am. Perfumer*, **37**, Dec. (1938), 34.
⁴ *Ber.* **70B** (1937), 2272. ¹⁵ *Monatsh.* **59** (1932), 161.
⁵ *J. Chem. Soc.* (1945), 540. ¹⁶ *J. Chem. Soc.* **61** (1892), 349.
⁶ *J. Am. Chem. Soc.* **38** (1916), 451. ¹⁷ *Ibid.* **81** (1902), 510.
⁷ *J. Chem. Soc.* (1945), 540. ¹⁸ *Ibid.* **61** (1892), 348.
⁸ *Ber.* **70B** (1937), 2272. ¹⁹ *Ibid.* **57** (1890), 324.
⁹ *Arch. Pharm.* **242** (1904), 288. ²⁰ *Chem. Zentr.* II (1901), 810.
¹⁰ *J. Chem. Soc.* **61** (1892), 344. ²¹ *J. Chem. Soc.* **81** (1902), 510.
¹¹ *Ibid.* (1936), 1831. ²² *Ibid.* **61** (1892), 350.
¹² *Arch. Pharm.* **242** (1904), 288. ²³ *Arch. Pharm.* **242** (1904), 288.

Osthole

C₁₅H₁₆O₃

Mol. Weight 244.28

Methyl ether of osthenole. 7-Methoxy-8-(γ,γ -dimethylallyl) coumarin.
 7-Methoxy-8-(3'-methyl butenyl-2') coumarin

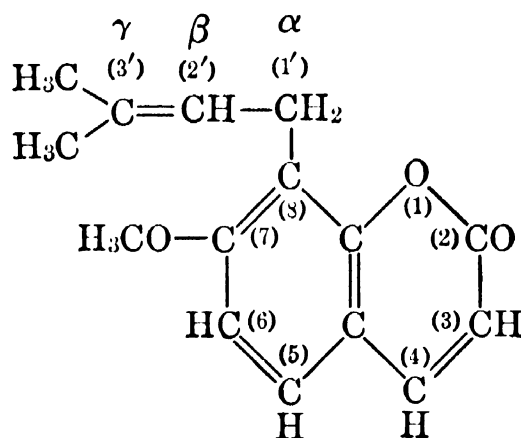

Occurrence.—A γ -lactone C₁₅H₁₆O₃ was first observed by Böcker and Hahn¹ in angelica root oil. More recently Späth and Pesta² found that this lactone was identical with osthole occurring in the root of masterwort (*Imperatoria ostruthium*).

Isolation.—Osthole can be isolated from the high boiling fractions of angelica root oil by suitable treatment with dilute alcoholic alkali solutions. (See "Introduction" to the section on "Lactones.")

Identification.—(1) According to Böcker and Hahn,³ osthole, on treatment with bromine in glacial acetic acid, yields a dibromide which, after recrystallization from glacial acetic acid, melts at 143°–145°.

(2) On treatment with hydrochloric acid, osthole yields a hydrochloride m. 101°.

Properties.—According to Späth and Holzen,⁴ osthole melts at 82°–83° (cryst. from petroleum ether or ether). When distilled in a high vacuum, osthole solidifies and melts at 62°–63°, but on long standing, seeding or heating to 50°–60°, osthole changes into the higher melting dimorphous form.

Osthole does not dissolve in cold or hot aqueous potassium or sodium hydroxide solutions but it dissolves in hot alcoholic potassium hydroxide solu-

tions. After saponification, the lactone can readily be regenerated, which proves that osthole is a γ -lactone.

Osthenole, the parent phenol of osthole, according to Späth and Bruck,⁵ melts at 124°–125°. This phenol is also present in angelica root oil.

Böhme and Pietsch⁶ showed that osthole, when oxidized with phthalic-mono-peracid in ethereal solution, yields a compound which on heating with 20 per cent sulfuric acid gives isoauraptene m. 64°–66°. This ketone forms an oxime m. 166°–167°.

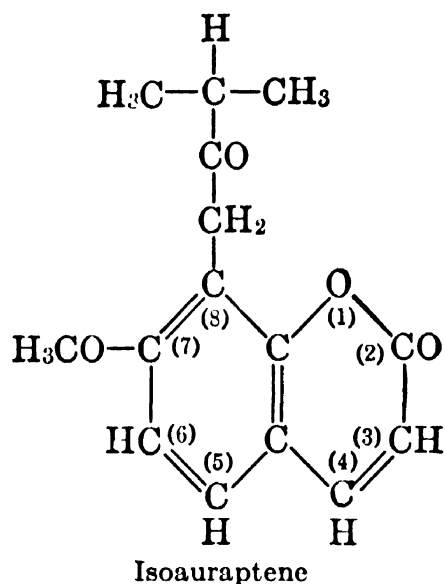

Use.—Osthole, as such, is not used in our industries.

¹ *J. prakt. Chem.* II, **83** (1911), 243.

² *Ber.* **67** (1934), 853. See also Späth and Vierhapper, *Monatsh.* **72** (1938), 179.

³ *J. prakt. Chem.* II, **83** (1911), 243.

⁴ *Ber.* **67B** (1934), 264.

⁵ *Ber.* **70B** (1937), 1023.

⁶ *Ber.* **72** (1939), 779.

Auraptene

$C_{15}H_{16}O_4$

Mol. Weight 260.28

Meranzin

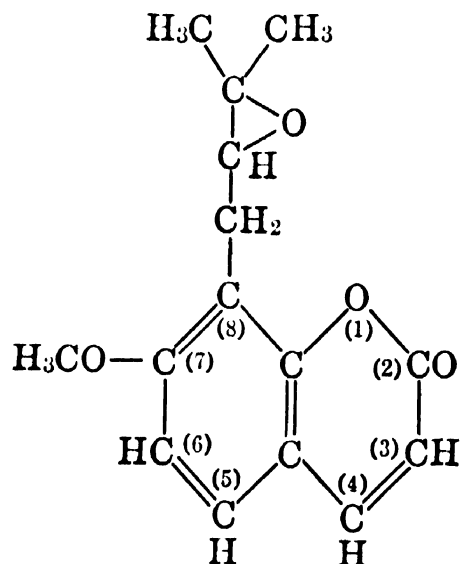

The constitution of this natural coumarin was elucidated by Böhme and collaborators.¹ Auraptene is closely related to osthole.

Occurrence.—According to Böhme and Pietsch,² auraptene occurs in the oils expressed from the peels of both the sweet and the bitter (sour) orange. The auraptene of Böhme and collaborators must not be confused with the "auraptene" (umbelliferone-4-heptylether $C_{16}H_{20}O_3$, m. 68°) that Komatsu and co-workers³ had isolated from grapefruit oil. In order to avoid confusion, Dodge⁴ suggested retaining the name auraptene for the compound described by Komatsu, and naming the coumarin derivative isolated by Böhme from orange oils meranzin, rather than auraptene. However, it seems that, due to the extensive work of Böhme, the designation auraptene will remain in literature.

Isolation.—Böhme and Pietsch⁵ isolated auraptene from orange oils by boiling and extracting the brown crystalline sedimentary deposit with petroleum ether.

Identification.—Böhme⁶ found that auraptene shows a most characteristic absorption spectrum in ultraviolet light. It was thus possible to identify auraptene in sweet as well as in bitter (sour) orange oil. Indeed, according to Böhme, the measuring of the absorption spectra permits definite conclusions as to the percentage of auraptene present in an oil. Since distilled orange oils contain no auraptene, a subnormal content of auraptene might indicate the addition of distilled orange oil to an expressed oil. Böhme also ventured the opinion that his findings might also be applied to expressed lemon, lime, and bergamot oils which contain the natural coumarin derivatives, limettin and bergaptene. Böhme measured the absorption spectra with the apparatus described by Eisenbrand.⁷

Properties.—According to Böhme and Pietsch,⁸ auraptene crystallizes in the form of colorless, tuft-like needles m. 91° . The alcoholic solutions $[\alpha]_D^{20} -33^\circ 24'$ show blue fluorescence. Auraptene is readily soluble in benzene, chloroform, ether, ethyl acetate, or concentrated acetic acid; and sparingly soluble in petroleum ether (ligroine). When treated with concentrated sulfuric acid, auraptene develops an orange-red color. With palladiumized charcoal and in acetic acid solution, auraptene yields dihydroauraptene m. 116° .

Treating a methyl alcoholic solution of auraptene with the calculated amount of sodium methylate, setting the mixture aside for several days at room temperature, distilling with water, and acidifying, Böhme and Pietsch⁹ obtained *cis*-auraptenic acid. On the other hand, *trans*-auraptenic acid will be formed if the solution of auraptene is treated for several hours on a hot water bath. *Cis*- and *trans*-auraptenic acid bear to one another the same relation as coumarinic and coumaric acid. However, *cis*-auraptenic acid shows no tendency toward reconversion to auraptene by ring closure. The reactivity of the phenolic group is greatly diminished.

In excess of sodium methylate, *cis*-auraptenic acid m. 150° , $[\alpha]_D^{15} +2^\circ$ (in alcohol) is converted into *trans*-auraptenic acid m. 204° , $[\alpha]_D^{20} +90^\circ 24'$ (in alcohol). Both acids on catalytic hydrogenation yield dihydroauraptenic acid m. 99° – 100° . The same acid can also be obtained by hydrogenation of auraptene in alkaline solution. When treated with acetic acid containing a

little sulfuric acid, auraptene yields isoauraptene m. 66° (see "Osthole") which is a ketone forming an oxime m. 166° – 167° .

On boiling with 1 per cent oxalic acid, auraptene yields an optically active glycol, auraptene hydrate m. 128° – 129° , $[\alpha]_D^{15} -43^{\circ} 48'$ (in alcohol), which on heating with sulfuric acid is converted to isoauraptene.

With dimethylamine in benzene at 150° , auraptene forms an amino alcohol m. 170° , $[\alpha]_D^{15} +78^{\circ} 48'$ (in alcohol).

Use.—Auraptene, as such, is not used in our industry.

¹ *Arch. Pharm.* **276** (1938), 482; **279** (1941), 213. *Ber.* **72B** (1939), 773. Böhme and Schneider, *ibid.*, 780.

² *Arch. Pharm.* **276** (1938), 482.

³ *J. Chem. Soc. Japan* **51** (1930), 478.

⁴ *Am. Perfumer* **41**, Nov. (1940), 31.

⁵ *Arch. Pharm.* **276** (1938), 482.

⁶ *Ibid.* **277** (1939), 61. See also van Os and Dykstra, *J. Pharm. Chim.* **25** (1937), 437, 485.

⁷ *Arch. Pharm.* **268** (1930), 520.

⁸ *Ibid.* **276** (1938), 482.

⁹ *Ber.* **72B** (1939), 773. *Chem. Abstracts* **33** (1939), 4974.

Hydroxypeucedanin

$C_{16}H_{14}O_5$

Mol. Weight 286.27

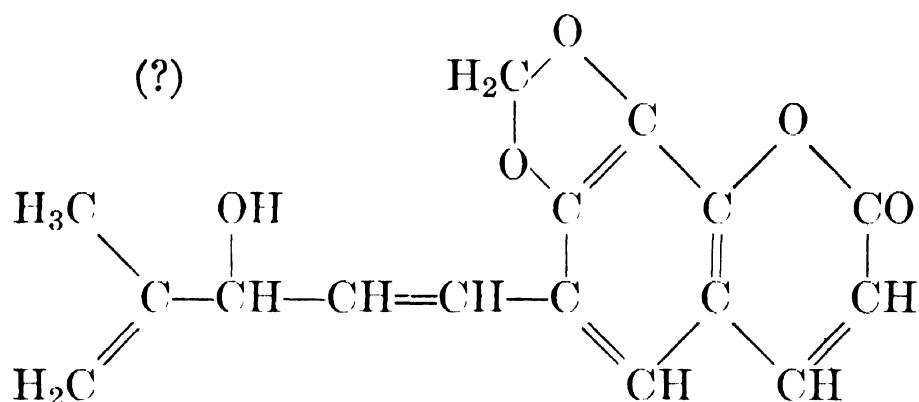

Occurrence.—Hydroxypeucedanin was isolated from the extracted oil of masterwort by Butenandt and Marten,¹ who assigned to it provisionally the structure pictured above.

Isolation.—By the usual methods of isolating coumarin derivatives (see "Introduction" to the section on "Lactones").

Identification.—Hydroxypeucedanin yields a hydrate m. 136° , an acetate m. 139° , a benzoate m. 172° – 172.5° , and a phenylurethane m. 174° .

Properties.—M. 142° .

By boiling with 10 per cent sulfuric acid, or by heating the compound *in vacuo* to 250° , hydroxypeucedanin is isomerized to isohydroxypeucedanin m. 148° .

Use.—Hydroxypeucedanin is not used in our industries.

¹ *Liebigs Ann.* **495** (1932), 205.

Ostruthin

 $C_{19}H_{22}O_3$

Mol. Weight 298.37

6-Geranyl-7-hydroxycoumarin

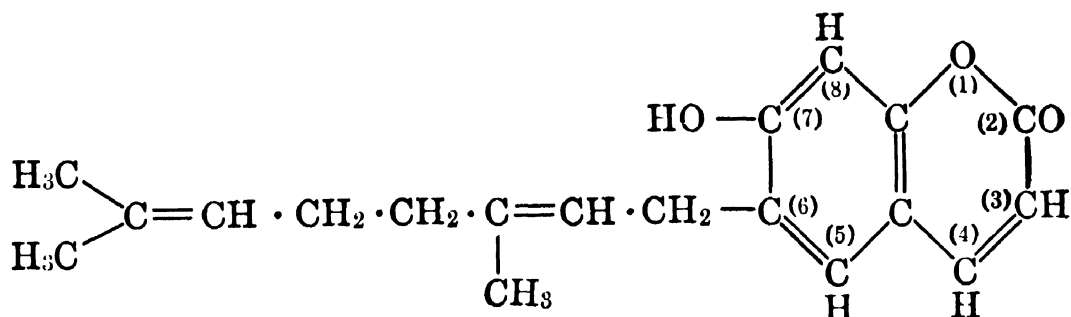

Occurrence.—According to Späth and Klager,¹ the roots of masterwort (*Peucedanum ostruthium* Koch), extracted with benzene, yield about 1.4 per cent of ostruthin. These authors also established the constitution of this lactone, modifying the formulas originally suggested by Butenandt and Marten.²

Isolation.—Through the usual methods of isolating coumarin derivatives. (See "Introduction" to this section.)

Identification.—By melting point determination.

The methyl ether melts at 55°; the acetyl derivative melts at 80°.

Properties.—Contrary to earlier findings, Späth and Klager³ reported the melting point of ostruthin as 119°.

Use.—Ostruthin is not used in the perfume or flavor industries.

¹ *Ber.* **67B** (1934), 859. See also *Liebigs Ann.* **495** (1932), 202.

² *Liebigs Ann.* **495** (1932), 187.

³ *Ber.* **67B** (1934), 863.

7-Methoxy-5-Geranoxycoumarin

 $C_{20}H_{24}O_4$

Mol. Weight 328.39

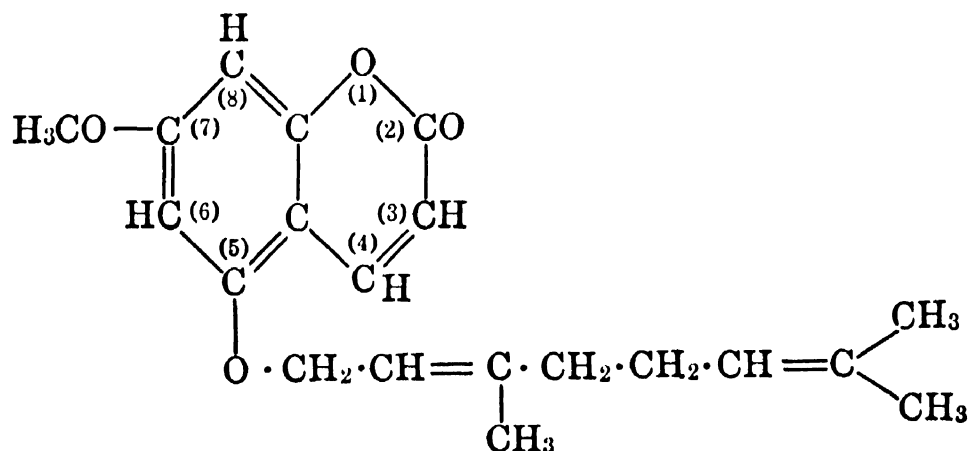

Occurrence.—According to Caldwell and Jones,¹ relatively large quantities (2.0–2.5 per cent) of this compound occur in expressed lime oil.

Isolation.—Removing 85% of the filtered lime oil by distillation *in vacuo*, Caldwell and Jones² obtained a residual pale brown oil with a bluish fluorescence from which

solid material separated on standing at 0° in methyl alcoholic solution. Fractional crystallization of this solid effected no appreciable purification, but chromatographic analysis on alumina from benzene solution resulted in a sharp separation into three fractions consisting of limettin, isopimpinellin, and 7-methoxy-5-geranoxycoumarin.

Identification.—By melting point determination and by spectrochemical means.

Properties.—7-Methoxy-5-geranoxycoumarin melts at 86°–87°.

Ozonolysis of 7-methoxy-5-geranoxycoumarin gave acetone and levulinic aldehyde in good yields, indicating the presence of a geranyl residue in the molecule, and on treatment with acetic acid containing a little sulfuric acid, a phenolic compound $C_{10}H_8O_4$, m. 228°–229° was produced.

According to Caldwell and Jones,³ the characteristic blue fluorescence of expressed lime oil should not be attributed, as has usually been done, to the presence of methyl anthranilate in the oil, but rather to 7-methoxy-5-geranoxycoumarin.

Use.—7-Methoxy-5-geranoxycoumarin, as such, is not used in our industries.

¹ *J. Chem. Soc.* (1945), 540.

² *Ibid.*

³ *Ibid.*

Umbelliprenin

$C_{24}H_{30}O_3$

Mol. Weight 366.48

Umbelliferone farnesyl ether

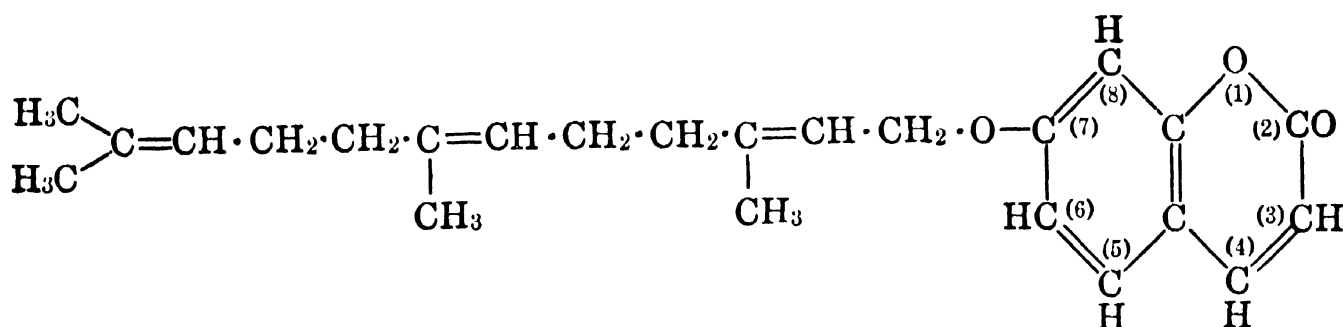

Späth and Vierhapper¹ expressed the opinion that umbelliprenin is the farnesyl ether of umbelliferone but attempts to establish the structure by synthesis were unsuccessful.

Occurrence.—Späth and Vierhapper² isolated this ether from angelica seed and named it umbelliprenin. According to the same authors,³ angelica seed contains 0.04 per cent umbelliprenin.

Isolation.—By the usual method of isolating coumarins and coumarin derivatives.

Identification.—By melting point determination.

Properties.—Umbelliprenin is optically inactive. Recrystallized from petroleum ether, it melts at 61°–63°, according to Späth and Vierhapper.⁴

Unlike bergamottin, umbelliprenin is not cleaved at the ether union by mere heating with glacial acetic acid. On treatment with cold glacial acetic

acid and sulfuric acid, umbelliprenin yields the alkali soluble umbelliferone and an alkali insoluble oil b_1 100° – 115° , of intense but not unpleasant odor.

Use.—Umbelliprenin, as such, is not used in the perfume or flavor industries.

¹ *Ber.* **71** (1938), 1667.

² *Ibid.*

³ *Monatsh.* **72** (1938), 179.

⁴ *Ber.* **71** (1938), 1671.

Tangeretin

$C_{20}H_{20}O_7$

Mol. Weight 372.36

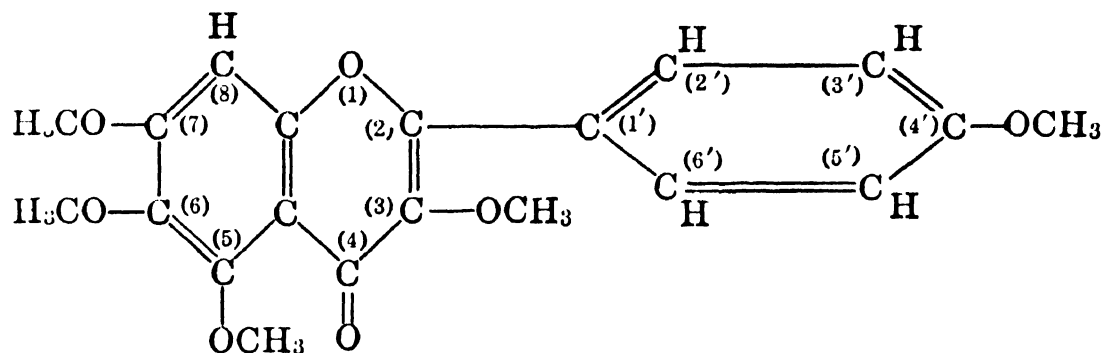

Occurrence.—Nelson ¹ isolated from expressed Florida tangerine oil a crystalline substance which he named tangeretin. According to Goldsworthy and Robinson,² who succeeded in synthesizing this substance, it has the molecular formula $C_{20}H_{20}O_7$ and is 3,5,6,7,4'-pentamethoxyflavone.

Isolation.—Tangeretin separates from tangerine oil on long standing.

Identification.—With concentrated hydrochloric acid, tangeretin forms an oxonium salt (yellow needles).

Alkaline hydrolysis yields anisic acid and a tetramethylketophenol, viz., tangeretol, the oxime of which, $C_{12}H_{17}O_6N$, melts at 85° – 87° (Goldsworthy and Robinson ³).

Properties.—M. 154° .

Treatment with ferric chloride and ethyl alcohol gives an olive-green color. Soluble in benzene from which tangeretin can be precipitated on the addition of petroleum ether. Soluble in hot alcohol or hot ethyl acetate, crystallizing from the solvents at room temperature. Insoluble in a 10 per cent solution of sodium hydroxide.

Use.—Tangeretin, as such, is not used in our industries.

¹ *J. Am. Chem. Soc.* **56** (1934), 1392. Cf. *Am. Perfumer* **29** (1934), 347.

² *J. Chem. Soc.* (1937), 46.

³ *Ibid.*

Bergaptol

 $C_{11}H_6O_4$

Mol. Weight 202.16

5-Hydroxypsoralene. 5-Hydroxyfurano-2',3',6,7-coumarin.

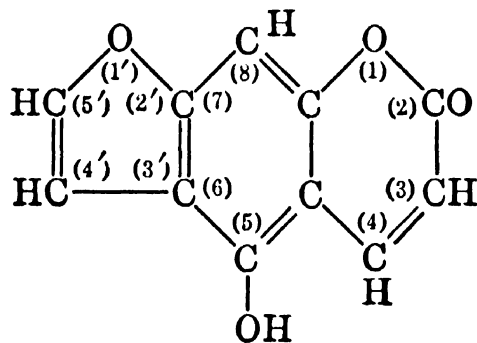

Occurrence.—This furo- (or furano-) coumarin derivative, parent substance of bergaptene, occurs in expressed bergamot oil. According to Caldwell and Jones,¹ expressed lime oil contains traces of bergaptol.

Isolation.—Späth and Socias² isolated bergaptol from bergamot oil by fractional distillation or, in better yield, by treatment with alkali (see "Introduction" to lactones).

Identification.—On methylation with diazomethane, bergaptol yields bergaptene m. 190°–191°. (See below.)

Properties.—According to Späth and Socias,³ bergaptol forms odorless crystals m. 280°–282°. Evaporating bergaptol slowly from a solution in ethyl acetate, Späth and Kubiczek⁴ obtained needles m. 276°–278° (*in vacuo*).

Use.—Bergaptol is not used in our industries.

¹ *J. Chem. Soc.* (1945), 540.

² *Ber.* **67B** (1934), 59.

³ *Ibid.*

⁴ *Ber.* **70B** (1937), 1253.

Xanthotoxol

 $C_{11}H_6O_4$

Mol. Weight 202.16

8-Hydroxypsoralene. 8-Hydroxyfurano-2',3',6,7-coumarin

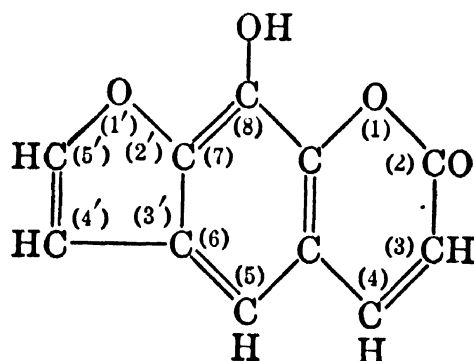

Occurrence.—According to Späth and Vierhapper,¹ the seed of angelica (*Angelica archangelica* L.) contains 0.02 per cent of xanthotoxol.

Isolation.—Späth and Vierhapper² isolated xanthotoxol from a phenol fraction $b_{0.05}$ 170°–180°.

Identification and Properties.—M. 249°–251°.

According to Späth and Pailer,³ xanthotoxol can be reduced to dihydro-xanthotoxol m. 202° (*in vacuo*).

Noguti and Kawakami⁴ isolated a compound $C_{11}H_6O_4$ from *Angelica glabra* Makino and reported it as xanthotoxol m. 145°. This is probably the methyl ether. (See "Xanthotoxin" below.)

Use.—Xanthotoxol is not used in our industries.

¹ *Monatsh.* **72** (1938), 179.

² *Ber.* **70B** (1937), 248.

³ *Ber.* **69B** (1936), 767.

⁴ *J. Pharm. Soc. Japan* **61** (1941), 77. *Chem. Abstracts* **36** (1942), 464.

Xanthotoxin

$C_{12}H_8O_4$

Mol. Weight 216.18

8-Methoxypsoralene. 8-Methoxyfurano-2',3',6,7-coumarin

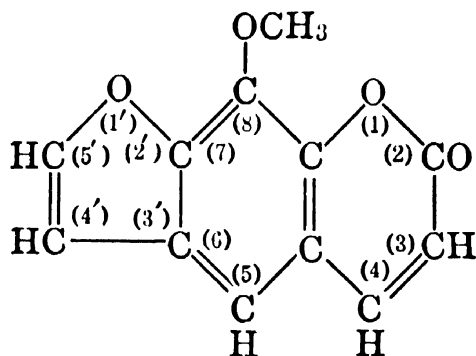

The constitution of xanthotoxin was established by Thoms.¹

Occurrence.—This isomer of bergaptene occurs in the oil distilled from the fruit peel of *Fagara xanthoxyloides* Lam. The yield of xanthotoxin is higher if the peels are extracted with alcohol. Späth and Vierhapper² found that the seed of angelica (*Angelica archangelica* L.) contains 0.02 per cent xanthotoxin.

Isolation.—By extraction of the oil with aqueous potassium hydroxide, and regeneration of the lactone, according to the usual principle applied for the isolation of coumarins and coumarin derivatives.

Identification.—(1) By melting point determination.

(2) By the preparation of derivatives:

(a) Nitrating xanthotoxin with nitric acid in glacial acetic acid at 90°, Thoms³ obtained nitroxanthotoxin which after recrystallization from nitrobenzene or alcohol melted at 233°. Priess⁴ used for the nitration 45 per cent nitric acid in the cold and obtained nitroxanthotoxin m. 230°.

(b) Priess⁵ prepared xanthotoxin dibromide by the action of bromine in chloroform solution. Recrystallized from xylene, the dibromide melted at 164° but was not very stable.

Properties.—According to Späth and Pailer,⁶ xanthotoxin melts at 146°, dihydroxanthotoxin at 163°. Thoms⁷ reported that xanthotoxin forms prisms from 80 per cent alcohol, needles from benzene and petroleum ether, m. 145°–146°. According to Priess,⁸ xanthotoxin m. 145° is sparingly soluble in water, ether, or petroleum ether, more soluble in acetone and glacial acetic acid; readily soluble in boiling absolute alcohol.

Xanthotoxin is only sparingly volatile with steam.

When treating the alcoholic solution of this lactone with potassium hydroxide, a yellow colored and water soluble salt is obtained from which xanthotoxin can be regenerated by neutralization of this solution.

Späth and collaborators⁹ reported on the ozonization of xanthotoxin.

Späth et al.¹⁰ succeeded in synthesizing xanthotoxin.

Use.—Xanthotoxin is not used in the perfume or flavor industries.

¹ *Ber.* **44** (1911), 3325. Thoms and Baetcke, *ibid.* **45** (1912), 2705.

² *Monatsh.* **72** (1938), 179.

³ *Ber.* **44** (1911), 3327.

⁴ *Ber. deut. pharm. Ges.* **21** (1910), 227. *Chem. Zentr.* II (1911), 94.

⁵ *Ibid.*

⁶ *Ber.* **69B** (1936), 767.

⁷ *Ber.* **44** (1911), 3325.

⁸ *Ber. deut. pharm. Ges.* **21** (1910), 227. *Chem. Zentr.* II (1911), 94.

⁹ *Ber.* **73B** (1940), 1361.

¹⁰ *Ber.* **69B** (1936), 767, 1087.

Bergaptene

C₁₂H₈O₄

Mol. Weight 216.18

5-Methoxypsoralene. 5-Methoxyfurano-2',3',6,7-coumarin. Heraclin.
"Bergamot camphor"

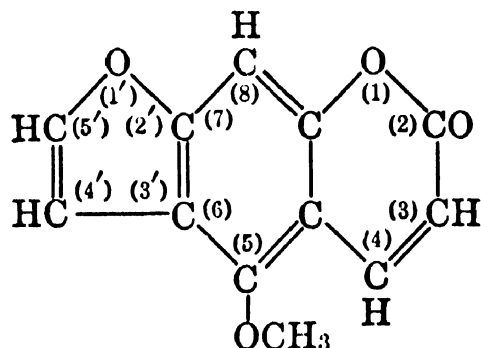

This methoxylated furocoumarin (or in another sense coumarin-coumarone) had been investigated by several earlier workers before its constitution was established by Thoms and Baetcke.¹ Bergaptene is an isomer of xanthotoxin. The identity of heraclin with bergaptene has been proved by Späth and Raschka.² Bergaptene is the methyl ether of bergaptol.

Occurrence.—Expressed oil of bergamot contains about 5 per cent of bergaptene. It has also been observed in the seed of *Seseli indicum* by Späth, Bose, Matzke and Guha,³ in the oil distilled from the leaves of *Skimmia*

laureola Hook. f., and in a few other oils. Späth and Vierhapper ⁴ found that the seed of angelica (*Angelica archangelica* L.) contains about 0.1 per cent of bergaptene.

Isolation.—Like all coumarin derivatives. (See "Introduction" to Lactones.)

Identification.—(1) By melting point determination.

(2) By the preparation of nitrobergaptene. Pomeranz ⁵ suggested the following method:

Dissolve 2 g. of bergaptene in glacial acetic acid and add 50 cc. of strongly cooled nitric acid (d 1.41). This mixture is allowed to stand for 20 min., when the light yellow needles are recrystallized from glacial acetic acid. At 230° the crystals turn brown, melting at 256° (with decomposition). They are insoluble in water, alcohol, or ether.

Properties.—Bergaptene sublimes. Traces are soluble in hot water; readily soluble in glacial acetic acid, chloroform, benzene and warm phenols (Pomeranz ⁶). Soluble in 60 parts of hot absolute alcohol (Gutzeit ⁷). Insoluble in hot alkali carbonate solutions but soluble in hot aqueous or in hot alcoholic potassium hydroxide (Pomeranz ⁸).

The melting point of bergaptene was reported as 188°–190° by Späth, von Wessely and Kubiczek, ⁹ while Späth and Kubiczek ¹⁰ recorded m. 224°.

At room temperature bergaptene is odorless and tasteless but on heating it emits vapors of aromatic odor.

Use.—Bergaptene, as such, is not used in the perfume or flavor industries.

¹ *Ber.* **45** (1912), 3705.

² *Ber.* **67** (1934), 62.

³ *Ber.* **72** (1939), 821.

⁴ *Monatsh.* **72** (1938), 179.

⁵ *Ibid.* **14** (1893), 29.

⁶ *Ibid.* **12** (1891), 380.

⁷ *Jahresber. Fortschritte Chem.* (1879), 905.

⁸ *Monatsh.* **12** (1891), 380.

⁹ *Ber.* **70B** (1937), 478.

¹⁰ *Ibid.*, 1253.

SUGGESTED ADDITIONAL LITERATURE

W. N. Howell and A. Robertson, "A Synthesis of Bergaptene," *J. Chem. Soc.* (1937), 293.

E. Späth and collaborators, "Synthesis of Natural Coumarins," *Ber.* **70** (1937), 248

Isopimpinellin

C₁₃H₁₀O₅

Mol. Weight 246.21

5,8-Dimethoxyfurano-2',3',6,7-coumarin

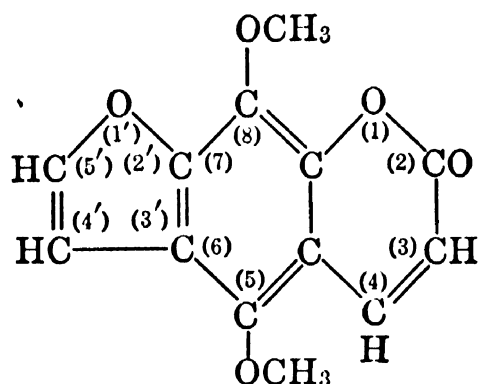

Occurrence.—Isopimpinellin has been identified in several members of the family *Umbelliferae*, viz., in *Pimpinella saxifraga* L. by von Wessely and Kallab,¹ in *Seseli indicum* Wall. by Späth, Bose, Matzke and Guha,² and in *Heracleum sphondylium* L. by Späth and Simon.³ It has furthermore been found in two members of the family *Rutaceae*, viz., *Luvunga scandens* Ham. by Späth, Bose, Schmid, Dobrovolny and Mookerjee,⁴ and in expressed lime oil, *Citrus aurantifolia* Swingle, by Caldwell and Jones.⁵

Isolation.—By the usual methods of isolating coumarins and coumarin derivatives, and by chromatographic analysis of the material deposited from expressed lime oil on standing. (See "7-Methoxy-5-Geranoxycoumarin.")

Identification.—By melting point determination and by spectrochemical data.

Properties.—

Compound	Caldwell and Jones ⁶	von Wessely and Kallab ⁷
Isopimpinellin	Yellow needles m. 147°–148°	Yellow needles m. 148°–151°
Methoxy acid obtained by fission of the lactone ring	m. 157°–158.5°	Sintering slightly at 143°, strongly at 156°, molten at 162°
Dihydrohydroxy acid obtained by sodium amalgam reduction of isopimpinellin	m. 139°, sintering at 131°	m. 141°, sintering at 130°
Dihydroisopimpinellin obtained by heating the above acid	m. 93.5°–94°	m. 95.5°

According to Späth and Simon,⁸ isopimpinellin melts at 147°–149°; according to Dodge,⁹ at 149.8°.

Use.—Isopimpinellin, as such, is not used in our industries.

¹ *Monatsh.* **59** (1932), 161.² *Ber.* **72** (1939), 821.³ *Monatsh.* **67** (1936), 344.⁴ *Ber.* **73** (1940), 1361.⁵ *J. Chem. Soc.* (1945), 540.⁶ *Ibid.*, 541.⁷ *Monatsh.* **59** (1932), 169, 170, 171.⁸ *Ibid.* **67** (1936), 344.⁹ *Am. Perfumer* **37**, Dec. (1938), 34.

Imperatorin

C₁₆H₁₄O₄

Mol. Weight 270.27

Xanthotoxol isoamylene ether. 8-Hydroxypsoralene isoamylene ether

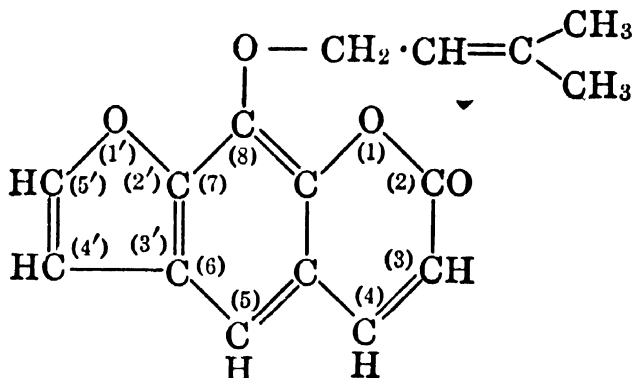

The structural formula of imperatorin was established by Späth and Holzen.¹

Occurrence.—More than one hundred years ago, Osan assigned the name imperatorin to the crude extract of masterwort (*Imperatoria ostruthium*). Späth and Vierhapper² found that the seeds of *Angelica archangelica* L. are particularly rich in imperatorin. Noguti and Kawakami³ reported that *Angelica glabra* Makino contains about 1.3 per cent of imperatorin.

Späth, Bose, Gruber and Guha⁴ proved that marmelosin isolated from the fruit of *Aegle marmelos* is identical with imperatorin.

Isolation.—By the usual method of isolating coumarins and coumarin derivatives from essential oils or plant extracts.

Identification.—By melting point determination.

According to Späth and Holzen,⁵ the hexahydroxy derivative of imperatorin melts at 85°.

Heating imperatorin in a 10% chloroform solution of perbenzoic acid, Noguti and Kawakami⁶ obtained hydroxyimperatorin C₁₆H₁₄O₅, m. 115°. Späth and Holzen⁷ had earlier reported the formation of the same hydroxyimperatorin.

Properties.—Imperatorin melts at 102° (Späth and Holzen⁸), m. 102°–103° (Späth, Bose, Gruber and Guha⁹).

Späth and Kuffner¹⁰ studied the rearrangement of imperatorin to *allo*-imperatorin (8-hydroxy-5-isoamylene-psoralene).

According to Späth and Holzen,¹¹ imperatorin is almost completely isomerized to *allo*-imperatorin on dry distillation even in a high vacuum; at somewhat higher pressures (0.5 mm.) the isomerization is complete. At 0.001 mm. pressure and 205°–215° bath temperature, *allo*-imperatorin sublimes. It melts at 233°. Similar observations were made by Noguti and Kawakami.¹²

Späth and Holzen¹³ reported that imperatorin is not appreciably soluble in aqueous potassium hydroxide but it dissolves with yellow color in cold methyl alcoholic potassium hydroxide and does not separate on dilution with water and evaporation of methyl alcohol *in vacuo*.

Noguti and Kawakami¹⁴ found that 2 g. of imperatorin in 20 cc. of glacial acetic acid on addition of 2 drops of concentrated sulfuric acid gave xanthoxol after standing for two days.

Späth and Kuffner¹⁵ studied the lethal action of imperatorin and other coumarin derivatives on fish.

Späth and collaborators¹⁶ succeeded in synthesizing imperatorin via xanthoxol.

Use.—Imperatorin, as such, is not used in the perfume or flavor industries.

- ¹ *Ber.* **66B** (1933), 1137.
- ² *Ber.* **70B** (1937), 248. *Monatsh.* **72** (1938), 179.
- ³ *J. Pharm. Soc. Japan* **61** (1941), 77. *Chem. Abstracts* **36** (1942), 464.
- ⁴ *Ber.* **70B** (1937), 1021.
- ⁵ *Ber.* **66B** (1933), 1141.
- ⁶ *J. Pharm. Soc. Japan* **61** (1941), 77. *Chem. Abstracts* **36** (1942), 464.
- ⁷ *Ber.* **68B** (1935), 1125.
- ⁸ *Ibid.*
- ⁹ *Ber.* **70B** (1937), 1021.
- ¹⁰ *Ber.* **72B** (1939), 1580.
- ¹¹ *Ber.* **66B** (1933), 1144.
- ¹² *J. Pharm. Soc. Japan* **61** (1941), 77. *Chem. Abstracts* **36** (1942), 464.
- ¹³ *Ber.* **66B** (1933), 1137.
- ¹⁴ *J. Pharm. Soc. Japan* **61** (1941), 77. *Chem. Abstracts* **36** (1942), 464.
- ¹⁵ *Monatsh.* **69** (1936), 108. *Chem. Abstracts* **31** (1937), 761.
- ¹⁶ *Ber.* **70B** (1937), 248, 478, 1253.

Isoimperatorin

$C_{16}H_{14}O_4$

Mol. Weight 270.27

Bergaptol isoamylene ether. 5-Hydroxypsoralene isoamylene ether

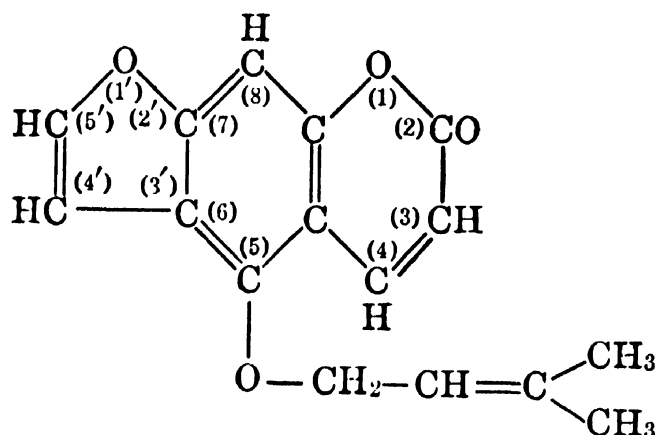

Occurrence.—According to Späth and Kahovec,¹ isoimperatorin occurs in the rhizomes of masterwort (*Peucedanum ostruthium* Koch syn. *Imperatoria ostruthium* L.). These investigators also established the structural formula of isoimperatorin as pictured above.

Isolation.—By the usual method of isolating coumarin derivatives.

Identification.—By melting point determination. Also, with dimethyl sulfate and sodium methylate an acid derivative $C_{17}H_{18}O_5$, m. 117.5°, is formed.

Properties.—According to Späth and Kahovec,² isoimperatorin melts at 109°. It is not appreciably soluble in cold aqueous alkali solutions but dissolves in methyl alcoholic potassium hydroxide. On the addition of water and evaporation of methyl alcohol, it remains in solution but precipitates unchanged by the action of acids (including carbon dioxide). Treating isoimperatorin with an acetic acid—sulfuric acid mixture, these same authors obtained a phenol m. 277° (with decomposition), which on methylation yielded bergaptene m. 188°–189°. When treated with dibenzoylperoxide, isoimperatorin in chloroform solution gives oxypeucedanin m. 142°–143°, according to Späth and Kahovec.³

Späth and Dobrovolny⁴ succeeded in synthesizing isoimperatorin.

Use.—Isoimperatorin, as such, is not used in the perfume or flavor industries.

¹ *Ber.* **66B** (1933), 1146.

² *Ibid.*

³ *Ibid.* See also Späth and Holzen, *Ber.* **68B** (1935), 1123.

⁴ *Ber.* **72** (1939), 52.

Bergamottin

C₂₁H₂₂O₄

Mol. Weight 338.39

Bergaptol geranyl ether

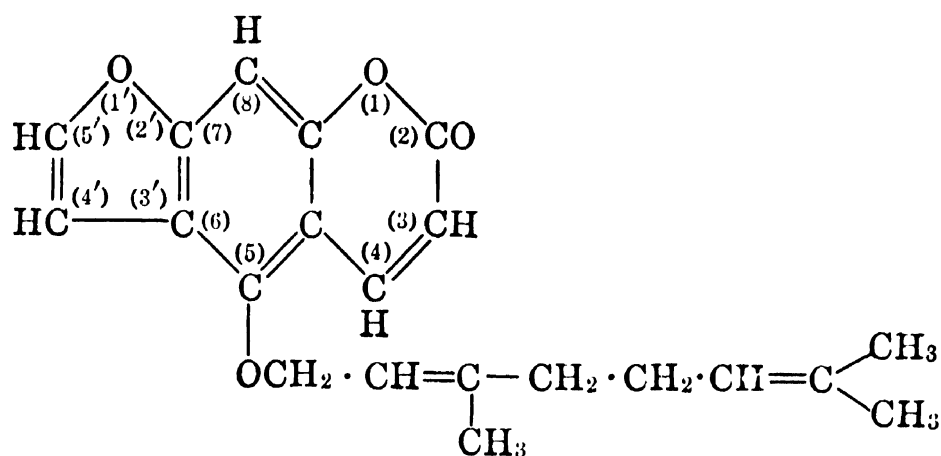

Occurrence.—Späth and Kainrath¹ isolated this geranyl ether of bergaptol from expressed bergamot oil.

Von Soden and Rojahn² had earlier observed in bergamot oil a nonphenolic substance which contained no methoxy group and which they called “bergaptin” m. 59.5°. This compound was probably bergamottin.

Isolation.—See “Introduction” to lactones. Also according to the method of Späth³ by which coumarins and coumarin derivatives are isolated from plant extracts and from volatile oils.

Identification.—By melting point determination.

Späth and Kainrath⁴ found that on distillation in a high vacuum bergamottin decomposes; at 200°–230° a crystalline phenol m. 275°–278° (*in vacuo*) distills over which was identified as bergaptol and which on methylation yielded bergaptene.

Properties.—M. 59°–61°, according to Späth and Kainrath.⁵

When heated with glacial acetic acid, bergamottin is split into bergaptol $C_{11}H_6O_4$, m. 280° , and geraniol.

Use.—Bergamottin, as such, is not used in our industries.

¹ *Ber.* **70B** (1937), 2272.

² *Pharm. Ztg.* **46** (1901), 778.

³ *Ber.* **70A** (1937), 83.

⁴ *Ibid.* **70B** (1937), 2272.

⁵ *Ibid.*

Angelicin

$C_{11}H_6O_3$

Mol. Weight 186.16

Furano-4',5',7,8-coumarin. Furo-4',5',7,8-coumarin

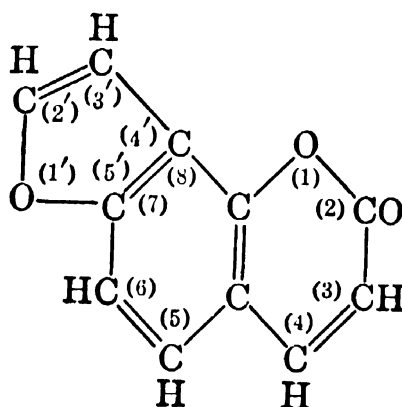

Occurrence.—This parent substance of several natural furocoumarins (for example, isobergaptene and pimpinellin)¹ has been found by Späth and Pesta² in oil of angelica root.

Originally the name angelicin had been assigned by Buchner³ to a substance which, however, was later identified as sitosterol.

Isolation.—See "Osthole."

Identification.—By melting point determination. According to Späth and Pesta,⁴ angelicin on oxidation with alkaline hydrogenperoxide yields furan-2,3-dicarboxylic acid.

Angelicin combines with benzene in the presence of aluminum chloride, according to Krishnaswamy and Seshadri,⁵ to yield 8-(1,2-diphenylethyl) umbelliferone, m. 205° – 206° . These authors recommended preparing the above derivative as follows:

Dissolve 0.2 g. of angelicin in 20 ml. of benzene, add 0.5 g. of powdered aluminum chloride and shake the stoppered flask well for about 4 hr. at room temperature. Add dilute hydrochloric acid and remove the excess benzene by steam distillation. On repeated recrystallization of the solid residue from ethyl alcohol or acetone, the umbelliferone is obtained.

Properties.—M. 138° – 139.5° .

On short standing in cold aqueous alkali solutions, angelicin is insoluble, but on heating it dissolves and can be precipitated by acidification.

Use.—Angelicin is not used in our industries.

¹ See von Wessely and Nadler, *Monatsh.* **60** (1932), 141, 161.

² *Ber.* **67B** (1934), 853. See Späth and Vierhapper, *Monatsh.* **72** (1938), 179.

³ *Liebigs Ann.* **42** (1842), 226.

⁴ *Ber.* **67B** (1934), 179, 853.

⁵ *Proc. Indian Acad. Sci.* **16A** (1942), 151. *Chem. Abstracts* **37** (1943), 1430.

Pimpinellin

C₁₃H₁₀O₅

Mol. Weight 246.21

5,6-Dimethoxyfurano-4',5',7,8-coumarin

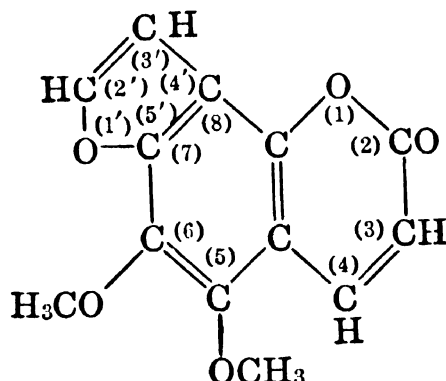

Occurrence.—Von Wessely and Kallab¹ found pimpinellin in the roots of *Pimpinella saxifraga* (5 kg. yielded 4–5 g.). Späth and Simon² identified pimpinellin in the roots of *Heracleum sphondylium*.

Isolation.—By the usual methods of isolating coumarin derivatives.

Identification.—By melting point determination.

Properties.—M. 119° (von Wessely and Kallab³). M. 117°–119° (Späth and Simon⁴).

On reduction, pimpinellin yields a dihydroderivative m. 87°–88°.

Von Wessely and Dinjaski⁵ investigated several polymerization products of pimpinellin.

Jois and Manjunath⁶ studied the absorption curves of pimpinellin, iso-pimpinellin, and several other furanocoumarins.

Wasicky⁷ investigated the physiological action of pimpinellin, ostruthin, and related compounds on animals.

Späth⁸ reported on the effects of natural coumarins, including pimpinellin, on fish.

Use.—Pimpinellin is not used in the perfume or flavor industries.

¹ *Monatsh.* **59** (1932), 161.

² *Ibid.* **67** (1936), 344.

³ *Ibid.* **59** (1932), 168.

⁴ *Ibid.* **67** (1936), 346.

⁵ *Ibid.* **64** (1934), 131.

⁶ *Ber.* **70B** (1937), 434.

⁷ *Pharm. Monatsh.* **17** (1936), 165. *Chem. Abstracts* **31** (1937), 453.

⁸ *Monatsh.* **69** (1936), 75.

Massoilactone

C₁₀H₁₆O₂

Mol. Weight 168.23

Lactone of 5-hydroxy-2-decenoic acid

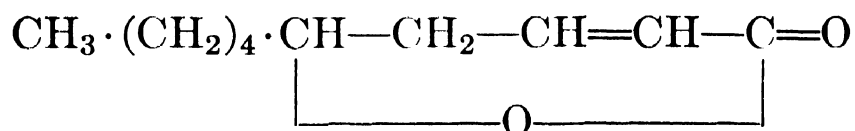

Occurrence.—According to Meijer,¹ this lactone occurs in the essential oil distilled from authentic Massoi bark *Cryptocaria massoia*, Lauraceae. Previously there had been considerable confusion regarding the origin of true Massoi bark, until the controversy was settled by an exploration trip to New Guinea where authentic species of the true Massoi bark were obtained.

Isolation.—(1) Shigehiro Abe² isolated this lactone from the essential oil of Massoi bark by extracting the oil with a solution of potassium hydroxide, in which process the lactone goes into solution. However, by this method the phenols, too, will be isolated.

(2) Meijer³ obtained the lactone from Massoi oil by fractional distillation.

Properties.—The fraction obtained had these properties:

b ₂₄	170°–174°	α _D	–93° 0' and –97° 0'
d ₄ ^{27.5}	0.9788	n _D ²⁶	1.4714
d ₄ ²⁰	0.9859	n _D ²⁰	1.4718

Catalytic hydrogenation of massoilactone with platinum oxide as a catalyst in a medium of glacial acetic acid yields the dihydrolactone which, on treatment with potassium bichromate and sulfuric acid, is oxidized to valeric, caproic, succinic and glutaric acids, and a keto acid, viz., δ-keto-capric acid m. 56.5°.

Use.—Massoilactone, as such, is not used in our industries.

¹ *Rec. trav. chim.* **59**, No. 3 (1940), 191.

² *J. Chem. Soc. Japan* **58** (1937), 246.

³ *Rec. trav. chim.* **59**, No. 3 (1940), 194.

Exaltolide

C₁₅H₂₈O₂

Mol. Weight 240.37

Lactone of 15-hydropentadecanoic acid

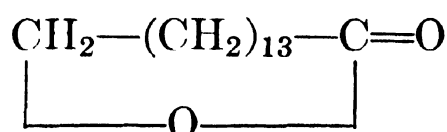

Occurrence.—This lactone was found by Kerschbaum¹ in the oil derived from angelica root (*Archangelica officinalis* syn. *Angelica archangelica*).

Isolation.—It was not possible to isolate exaltolide in pure form. The investigations of Kerschbaum,² and Ciamician and Silber³ showed the presence of an ether or lactone of 15-hydroxypentadecanoic acid. Ruzicka and Stoll⁴ succeeded in synthesizing exaltolide through oxidation of cyclopentadecanone with persulfuric acid.

Identification.—Through the 15-hydroxypentadecanoic acid m. 81°–82°.

Properties.—According to Stoll and Rouvé,⁵ and Ruzicka and Stoll,⁶ exaltolide has these properties:

m.	30°–32° ^{5, 6}	n_D^{41}	1.4633 ⁶
$b_{0.06}$	111°–112° ⁵	n_D^{31}	1.4670 ⁵
d_4^{41}	0.9383 ⁶		
d_4^{33}	0.9462 ⁵		

The odor of exaltolide is typical of amber and musk.

Use.—Exaltolide is used in high-grade perfumes, to which it imparts a lasting and characteristic odor.

¹ *Ber.* **60** (1927), 902.

² *Ibid.*

³ *Ber.* **29** (1896), 1811

⁴ *Helv. Chim. Acta* **11** (1928), 1159.

⁵ *Ibid.* **17** (1934), 1283.

⁶ *Ibid.* **11** (1928), 1167.

Ambrettolide

$C_{16}H_{28}O_2$

Mol. Weight 252.38

Lactone of 16-hydroxy-7-hexadecenoic acid

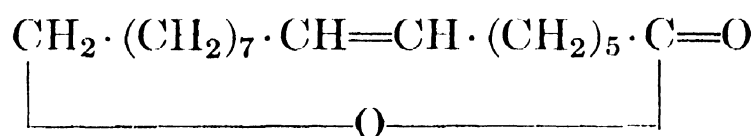

Occurrence.—This lactone occurs in oil of ambrette seed (*Hibiscus abelmoschus* L.).

Isolation.—Kerschbaum¹ isolated ambrettolide from ambrette seed oil by fractionation, after the fatty acids had been removed through treatment of the oil with a cold dilute sodium hydroxide solution. The fraction b_{10} 140°–180° was then carefully treated with dilute alcoholic sodium hydroxide and extracted with ether which procedure yielded a mixture of ambrettolide and farnesol. The latter was removed with phthalic anhydride while repeated fractionation of the residual mixture gave fairly pure ambrettolide b_{16} 185°–190°, d_{20} 0.938.

Identification.—Through ring-opening and by hydrolysis, ambrettolic acid m. 25° is formed.

Properties.—Ambrettolide is a colorless viscid oil which in 1 per cent alcoholic solution shows a delicate yet pronounced odor of musk.

According to Stoll and Gardner,² the ambrettolide described by Kerschbaum³ was impure. Stoll and Gardner reported these properties for analytically pure ambrettolide:

b_1	154°–156°
d_4^{20}	0.9580
n_D^{20}	1.4815

Use.—Natural ambrettolide, as such, is not used in our industries, but the synthetic product is offered on the market.

¹ *Ber.* **60** (1927), 908.

² *Helv. Chim. Acta* **17** (1934), 1609.

³ *Ber.* **60** (1927), 902.

SUGGESTED ADDITIONAL LITERATURE

Charles Collaud, "Ambrettolide and Its Isomers. Synthesis of a 16-Hydroxy-6-Hexadecenoic Acid and Its Lactone," *Helv. Chim. Acta* **25** (1942), 965. *Chem. Abstracts* **37** (1943), 1697.

Charles Collaud, "Ambrettolide and Its Isomers. Δ^5 - and Δ^6 -Isoambrettolic Acids and Lactones," *Helv. Chim. Acta* **26** (1943), 849. *Chem. Abstracts* **38** (1944), 1471.

Nepetalactone

$C_{10}H_{14}O_2$

Mol. Weight 166.21

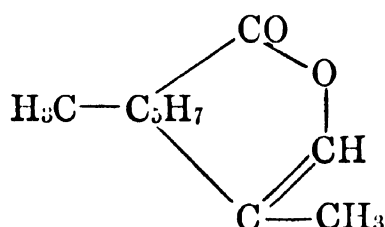

$\text{>}C_5H_7-CH_3$ is a methylcyclopentane nucleus (see "Nepetalic Acid").

Occurrence.—According to McElvain, Walters and Bright,¹ nepetalactone comprises about 42 per cent of the alkali-insoluble portion (10 per cent) of the volatile oil derived from catnip (*Nepeta cataria*).

Isolation and Identification.—The fraction $b_{0.3}$ 68°–71° of the lower boiling neutral components of volatile catnip oil is shaken with 10% aqueous sodium hydroxide at 80° for 30 min., the hydrocarbons are removed by extraction with ether, the alkaline extract is then acidified with 10% sulfuric acid to Congo red and thoroughly extracted with ether. On distillation, the combined ether extracts yield nepetalic acid which can be characterized by the preparation of its semicarbazone m. 160°–161° (see "Nepetalic Acid").

Properties.—According to McElvain et al.,² nepetalactone prepared from nepetalic anhydride has these properties:

$b_{0.1}$	67°–70°
n_D^{28}	1.4843

Use.—Nepetalactone, as such, is not used in our industries, but nepetalactone is the component of the oil, the odor of which makes the catnip plant so attractive to certain species of the cat family that they become playfully excited.

¹ *J. Am. Chem. Soc.* **64** (1942), 1828.

² *Ibid.*

Alantolactone

$C_{15}H_{20}O_2$

Mol. Weight 232.31

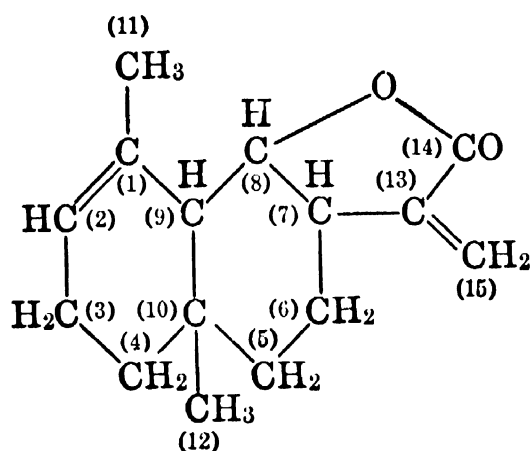

Alantolactone
(Helenine)

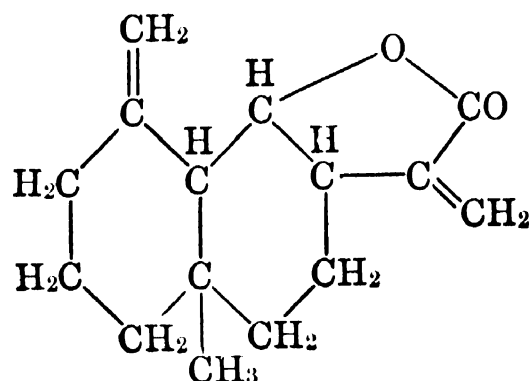

Isoalantolactone
(Isohelenine)

The work of Hansen,¹ and Ruzicka and van Melsen² indicates that the isomeric alantolactones have the formulas pictured above, but later investigations led Ruzicka, Pieth, Reichstein and Ehmann³ to the conclusion that alantolactone is not a uniform substance and that the above structural formulas apply only to certain constituents of the mixtures called alantolactone and isoalantolactone.

Occurrence.—This lactone forms the main constituent of elecampane oil (*Inula helenium*). It has also been detected in microsublimation products of *Radix enulae* by Fischer and Ehrlich.⁴

Isolation.—According to Hansen⁵ by a method which, although causing considerable losses, yet has been found to yield well-crystallized isomers. It involves distillation of the alant-camphor in a high vacuum, treating the crystalline distillate in cold alcohol with ammonia and filtering off the amides. The two amides are separated by fractional crystallization from ethyl acetate and acetone and converted back to the lactones by dry distillation in vacuo.

Alantolactone amide	m. 205°–206°
Isoalantolactone amide	m. 247°

On warming with dilute alkali solution, the lactones form salts of the corresponding hydroxy acids, viz., $C_{14}H_{20} \cdot OH \cdot COOH$. The acid derived from alantolactone melts at 135°–136°, that from the isolactone at 143°.

Identification.—Alantolactone can be characterized by the preparation of several crystalline derivatives:

- (1) Monohydrochloride m. 117°.
- (2) Monohydrobromide m. 106°.

(3) Dihydrochloride m. 127°–134°.

(4) Dihydrobromide m. 117°.

(5) Refluxing either alantolactone or isoalantolactone with selenium yields a 1,7-methyl-ethyl naphthalene (styphnate m. 125°–126°, picrate m. 101°). Upon oxidation with potassium ferricyanide and potassium hydroxide a 1,7-naphthalenedicarboxylic acid m. 294°–296° is obtained.

(6) Reduction of either of these isomers by means of a platinum oxide catalyst yields tetrahydroalantolactone m. 143°–144°, $\alpha_D +15^\circ 12'$. Partial hydrogenation of the same gives different derivatives:

Dihydroalantolactone	m. 134°, $\alpha_D -24^\circ 36'$
Dihydroisoalantolactone	m. 167.5°–168°, $[\alpha]_D^{22} +72^\circ 0'$

Properties.—Alantolactone forms colorless prismatic needles m. 76° and possesses a faint odor and flavor. It sublimes even on slight warming. The iso- form melts at 112°.

Bredt and Posth ⁶ reported these properties for alantolactone:

b.	275° (with partial decomposition)
b ₁₀	192°

Use.—For years alantolactone has been used as an efficient internal anti-septicum and vermifuge. The commercial product is known under the name “helenine” (alant-camphor) [cf. U. S. Dispensatory, 23rd Ed. (1943), 1406].

¹ *Ber.* **64** (1931), 67, 943, 1904. *J. prakt. Chem.* **136** (1933), 185.

² *Helv. Chim. Acta* **14** (1931), 397, 1095.

³ *Ibid.* **16** (1933), 268.

⁴ *Mikrochemie, Festsch. von Hans Molisch* (1936), 103.

⁵ *Ber.* **64B** (1931), 70.

⁶ *Liebigs Ann.* **285** (1895), 349.

n-Butyl Phthalide

C₁₂H₁₄O₂

Mol. Weight 190.23

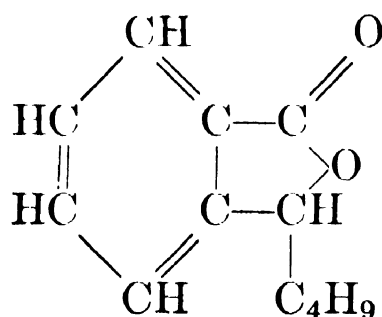

Occurrence.—Naves ¹ identified this compound as an important constituent of oil of lovage root (*Levisticum officinale* Koch).

Isolation.—To isolate the various lactone derivatives, the corresponding sodium salts are extracted with ether, in a medium saturated with carbon dioxide. The first fractions thus extracted are optically active ($-3^\circ 23'$) and particularly rich in butyl phthalide and its hydrogenated derivatives. As soon as the extraction slows up, the acids are freed by acidification with sulfuric acid (Congo red) and gradually lactonized by heating to 35°–40° at reduced pressure, every step in the separation being assured

by a treatment with a solution of sodium carbonate. The last fractions lactonized contain sedanonic anhydride.

The fractions containing the butyl phthalide are converted into methyl esters. After treatment with semicarbazide, they are then saponified and the salts digested with potassium permanganate. The recovered acids are finally lactonized by distillation.

Identification.—The resulting *n*-butyl phthalide can be identified by saponification to *o*-[α -hydroxyamyl]-benzoic acid m. 73°, by preparation of the mononitro derivative m. 54°–55°, and by comparison of these compounds with the corresponding synthetic products.

Properties.—According to Naves,² synthetic *n*-butyl phthalide has these properties:

b _{2.4}	141°
d ₄ ²⁰	1.0672
n _D ²⁰	1.52602

The natural *n*-butyl phthalide isolated by Naves³ from oil of lovage root had a boiling point b_{2.5} 138°–142°.

Use.—Synthetic *n*-butyl phthalide offers interesting possibilities in flavor work.

¹ *Helv. Chim. Acta* **26** (1943), 1281.

² *Ibid.*, 1284.

³ *Ibid.*, 1292.

n-Butylidene Phthalide

C₁₂H₁₂O₂

Mol. Weight 188.22

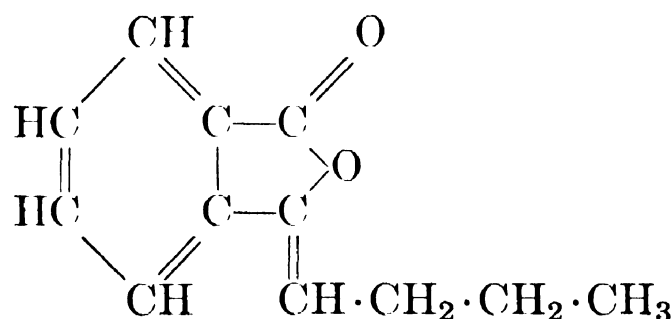

Occurrence.—This compound was first reported as “Ligusticum lactone” and derived from “Ligusticum acid,” C₁₂H₁₆O₃, by Kariyone, Kanno and Sugino¹ in the volatile oil distilled from a benzene extract of the fruit of *Ligusticum acutilobum* Sieb. and Zucc. Shortly afterward, Kariyone and Kotani² identified “Ligusticum lactone” with butylidene phthalide, while Noguchi, Fujita and Kawanami³ isolated this compound from the volatile oil obtained by steam distillation of the root of *Ligusticum acutilobum*.

More recently, Naves⁴ identified butylidene phthalide as a main constituent of oil of lovage root (*Levisticum officinale* Koch).

Isolation.—To isolate lactone compounds like butylidene phthalide, etc., the corresponding sodium salts are extracted with ether, in a medium saturated with carbon dioxide.

Naves ⁵ employed the following procedure for the isolation of *n*-butylidene phthalide:

"Transform 16 g. of the medium fractions * into methyl esters by treatment with a mixture of 30 cc. of absolute methyl alcohol and 1.5 cc. of concentrated sulfuric acid. Treat the ester mixture with 12 g. of triethyl borate at 120°–130°, and distill the reaction product to b_{2.5} 156°. Treat the distillate with 250 cc. of a potassium permanganate solution, and saponify the resulting neutral fraction for 1 hr. by refluxing with 60 cc. of 2 *N* alcoholic potassium hydroxide." The *n*-butylidene phthalides obtained after lactonization will have the properties reported below.

Identification.—The acid resulting from the treatment of 1 g. of lactone with 2 cc. of a 25% potassium hydroxide solution at 40° is freed by the addition of sulfuric acid, and refluxed for 3 hr. with 1.5 cc. of hydrazine hydrate in the presence of 10 cc. of alcohol. After purification by dissolution in acetic ester and precipitation with pentane, the *n*-butyl phthalazone will melt at 156°.

Properties.—According to Naves, ⁶ *n*-butylidene phthalide has these properties:

	b.	d_4^{20}	n_D^{20}
Natural	b _{1.5} 134°	1.0966	1.5759
Synthetic	b _{2.4} 141°	1.1028	1.5780

Use.—Synthetic *n*-butylidene phthalide is used in flavor work.

¹ *J. Pharm. Soc. Japan* **56** (1936), 113.

² *Ibid.* **57** (1937), 183.

³ *Ibid.*, 187.

⁴ *Helv. Chim. Acta* **26** (1943), 1281.

⁵ *Ibid.*, 1292.

⁶ *Ibid.*, 1285.

Sedanolid and "Cnidium Lactone"

C₁₂H₁₈O₂

Mol. Weight 194.26

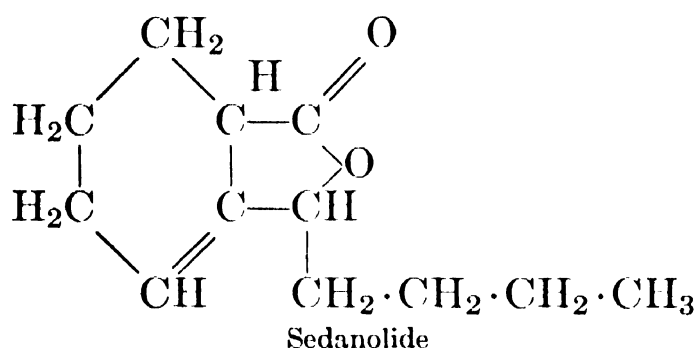

Δ²-Tetrahydro-*n*-butyl phthalide

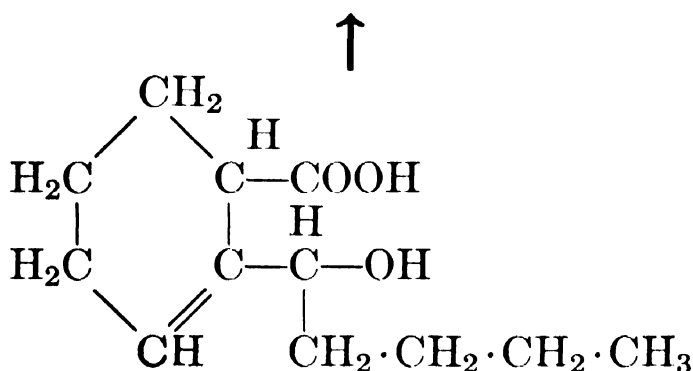
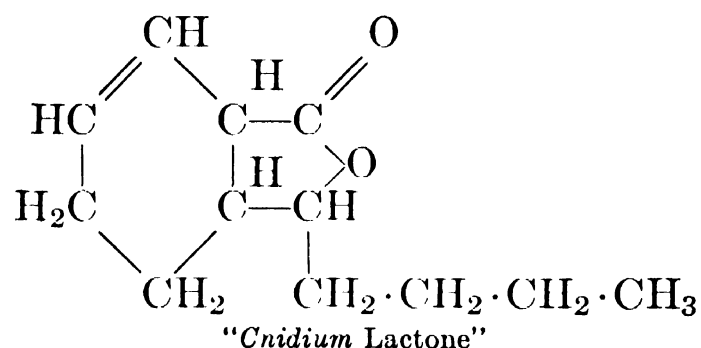

1- α -Hydroxy amyl- Δ^2 -tetrahydrobenzoic acid

Occurrence.—Sedanolid, the lactone of sedanolic acid (C₁₂H₂₀O₃, m. 88°–89°), is one of the principal odoriferous substances of oil of celery seed; first

* See in this connection the monograph on *n*-Butyl Phthalide, re isolation.

described by Ciamician and Silber.¹ An isomeric lactone was later isolated by Sakai,² and Murayama³ from the essential oil contained in the roots of the Chinese drug "Hsiung-Ch'uang" (*Cnidium officinale* Makino). This $C_{12}H_{18}O_2$ compound was named "*Cnidium* Lactone."

Isolation.—After first removing the free acids and phenols by sodium carbonate and hydroxide, both sedanolide and "*Cnidium* lactone" upon saponification and acidification yield hydroxy acids which serve as a means of isolation. However, the acid derived from "*Cnidium* lactone" is reported to be much more unstable than sedanolic acid, the 1- α -hydroxy-amyl- Δ^2 -tetrahydrobenzoic acid derived from sedanolide. Nevertheless the lactones are in part regenerated by distillation under diminished pressure. (See in this connection also the monograph on "Sedanonic Acid," regarding isolation.)

Identification.—Noguchi⁴ established the following series of reaction products that may serve to identify both "*Cnidium* lactone" and sedanolide as well as to show the relationship existing between these $C_{12}H_{18}O_2$ isomeric lactones:

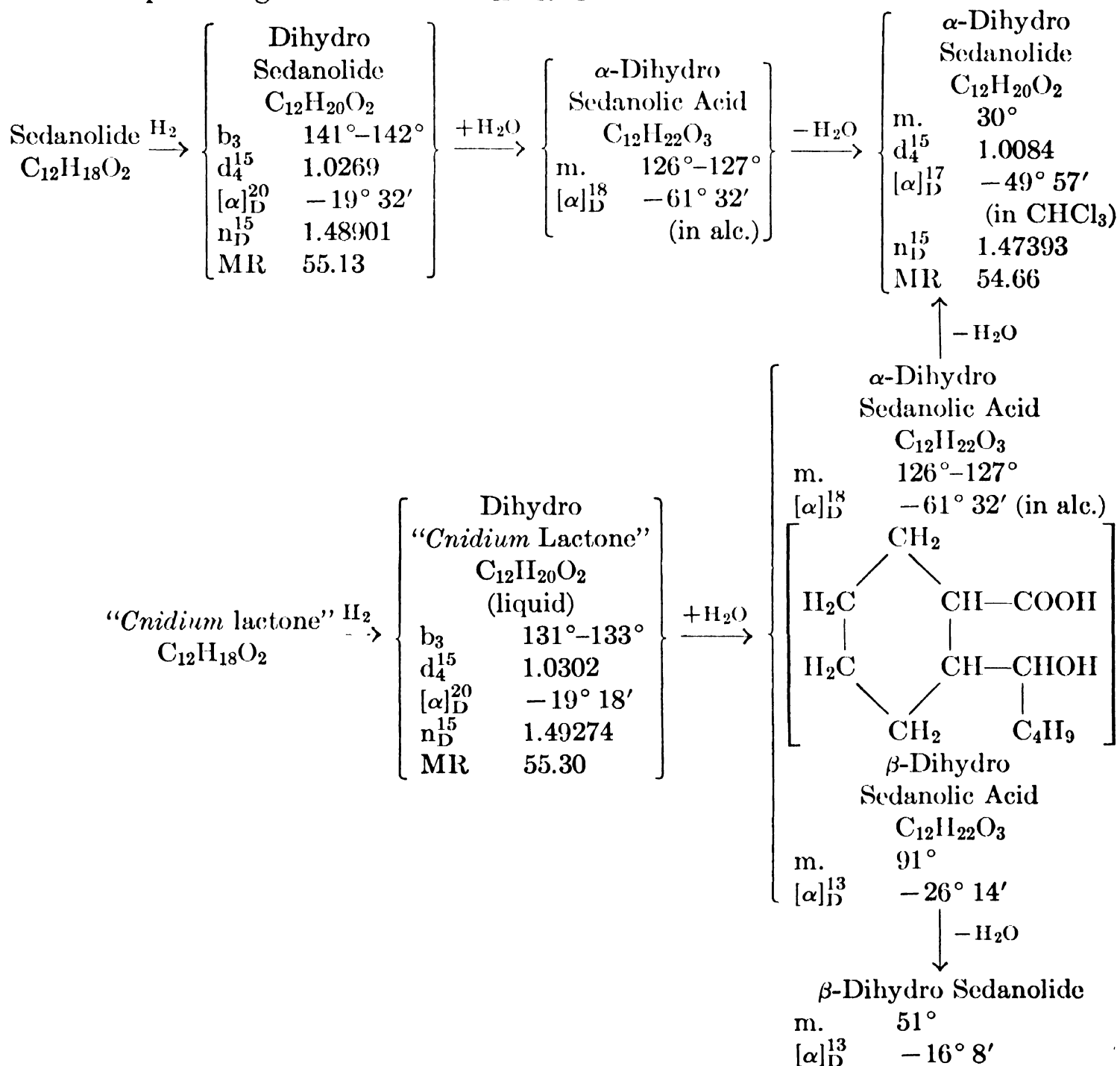

Noguchi and Kawanami⁵ report that heating either sedanolide or "*Cnidium* lactone" for 3 hr. with palladiumized charcoal at 330°-340° yields butyl phthalide, which upon nitration gives 6-nitrobutyl phthalide m. 53°-54°.

Properties.—Ciamician and Silber ⁶ recorded these properties for sedanolide:

b_{17}	185°	$[\alpha]_D^{26.5}$	-23° 40'
$d_{24.5}$	1.03833	$n_D^{24.5}$	1.49234

Noguchi ⁷ describes "*Cnidium lactone*" as follows:

b_{15}	177°-178°	$[\alpha]_D^{15}$	-71° 53' (in chloroform)
$b_{2.5}$	148°-150°	n_D^{15}	1.50545
d_4^{15}	1.0467		

Use.—Sedanolide or "*Cnidium lactone*," as such, are not used in our industries.

¹ *Ber.* **30** (1897), 492, 500, 1419, 1424, 1427.

² *Mitt. Medic. Ges. Tokio*, No. 6 (1916), 358; through *J. Pharm. Soc. Japan* **54** (1934), 171 (Abstracts in German).

³ *J. Pharm. Soc. Japan* No. 477 (1921), 951 (Abstracts in German p. 7). *Chem. Abstracts* **16** (1922), 1578.

⁴ *J. Pharm. Soc. Japan* **54** (1934), 913. *Chem. Abstracts* **31** (1937), 101.

⁵ *J. Pharm. Soc. Japan* **57** (1937), 191. *Chem. Zentr.* II (1937), 4050.

⁶ *Ber.* **30** (1897), 500. *Gazz. chim. ital.* **28**, I (1898), 478.

⁷ *J. Pharm. Soc. Japan* **54** (1934), 915. *Chem. Abstracts* **31** (1937), 101.

X. FURAN DERIVATIVES

Menthofuran

$C_{10}H_{14}O$

Mol. Weight 150.21

4,5,6,7-Tetrahydro-3,6-dimethylbenzofuran. 3,6-Dimethyl coumaronetetra-
hydride-(4,5,6,7)

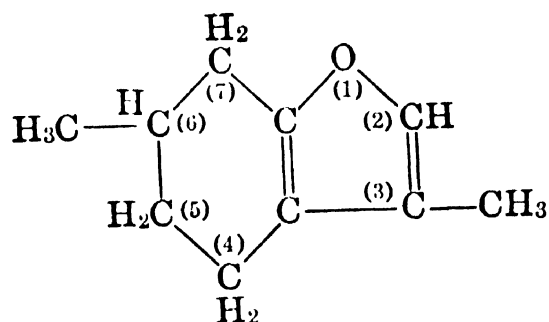

Occurrence.—Some years ago, Carles¹ observed in the oil distilled from the flower buds of peppermint a new constituent to which Wienhaus and Dewein² assigned the formula 3,6-dimethyl coumaronetetrahydride-(4,5,6,7) and named it menthofuran. This compound seems to form gradually in the plant, reaching a maximum (about 10 per cent of the oil) during the period of fluorescence and slowly disappearing as the content of menthol increases.

Isolation.—Carles³ isolated menthofuran from an oil distilled from fresh flowering peppermint by heating the fraction b_{10} 70° – 75° repeatedly over metallic sodium, by converting the menthone into menthol, and by removing the menthol with phthalic anhydride.

Identification.—Through its properties and the formation of an adduct with maleic anhydride m. 138° , according to Treibs.⁴

Properties.—Carles thus obtained an oil which admittedly still contained as much as 6 per cent menthol; it had these properties:

b.	196°	α_D	$+81^{\circ} 0'$ to $+88^{\circ} 0'$
b_{20}	95°	n_D^{20}	1.4807
d_{15}	0.965		

These properties were in a large measure confirmed by Treibs⁵ who, at a later date, obtained the same compound by heating cyclopulegone sulfonic ester; it had these characteristics:

b_{18}	80°	α_D	$+92^{\circ} 0'$
d_{15}	0.972	n_D	1.4890

The odor of this product was menthol-like; the color, typical blue.

On exposure to air, menthofuran yields an acid m. 185° – 186° , $C_7H_{10}O_2$.

Use.—According to a patent of Treibs,⁶ menthofuran may be used in perfumery; nevertheless it is seldom employed (if at all).

¹ *Parfumerie moderne* **22** (1929), 615.

² *Z. angew. Chem.* **47** (1934), 415.

³ *Parfumerie moderne* **22** (1929), 615.

⁴ *Ber.* **70B** (1937), 85.

⁵ *Ibid.*

⁶ German Patent No. 696,775, Aug. 29, 1940.

SUGGESTED ADDITIONAL LITERATURE

P. Z. Bedoukian, "Occurrence of Menthofuran in Oil of Peppermint (*Mentha piperita vulgaris* S.)," *J. Am. Chem. Soc.* **70** (1948), 621.

Perillene

C₁₀H₁₄O

Mol. Weight 150.21

β -Isohexenyl-furan

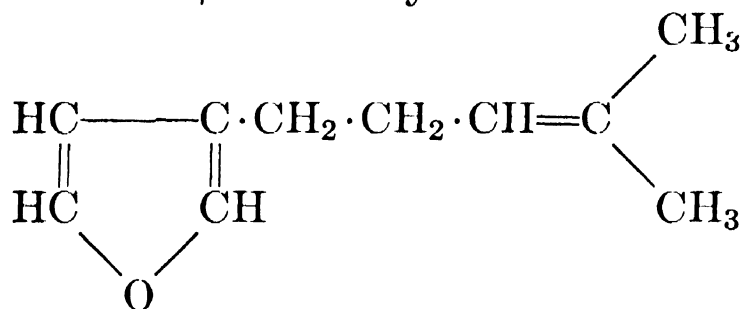

Occurrence.—Kondo and Yamaguchi¹ isolated from oil of *Perilla citriodora* a furfuran derivative C₁₀H₁₄O, which they named perillene, a rather misleading designation as this term would indicate a hydrocarbon. By comparing the reduction products of Elsholtzia ketone with dihydroperillene, Asana² demonstrated the formula originally suggested by the discoverers to be incorrect. The structure of perillene pictured above was finally established by Kondo and Suzuki.³

Goto⁴ reported a relative of this furan derivative in oil of *Perilla frutescens* Brit.

Isolation.—According to Kondo and Yamaguchi,⁵ the essential oil is freed of aldehydes by means of sodium bisulfite, and the furan derivative isolated from the low boiling fraction of neutral constituents by fractionation.

Identification.—Kondo and Suzuki⁶ noted that the isolate yields an octahydro derivative upon catalytic hydrogenation and cleavage of the furan ring with platinum oxide in acetic acid at 35 lb. of pressure. Oxidation of this derived primary alcohol by chromic oxide in acetic acid leads to [(CH₃)₂CH(CH₂)₃CH(C₂H₅)COOH], b₂₋₃ 117°–118°, d₄²⁰ 0.91058, which forms an anilide m. 68° and an amide m. 88°.

Properties.—According to Kondo and Yamaguchi,⁷ perillene has these properties:

b.	185°–186°	α_D	$\pm 0^\circ$
d ₄ ²⁰	0.9017	n _D ²¹	1.47053

These characteristics are in large measure confirmed by the work of other authors.

Kondo and Suzuki ⁸ prepared hydrogenated perillenes and reported for the dihydro derivative: *b*. 182°, d_4^{22} 0.8852, n_D^{22} 1.45762; for the hexahydro derivative: b_{10} 86°–87°, d_4^{20} 0.87363, $n_D^{21.7}$ 1.436226; for the octahydro derivative: *b*. 212°–213°, b_4 90°–91°, d_4^{20} 0.85568.

Perillene is a colorless liquid of agreeable odor; it gradually turns brown on standing.

Perillene gives a pale yellow color only with ferric chloride and a cherry red tint with sulfuric acid.

Use.—Perillene is not used in our industries.

¹ *J. Pharm. Soc. Japan* **446** (1919), 263.

² *J. Pharm. Soc. Japan* **454** (1919), 999.

³ *Ber.* **69B** (1936), 2459. See Suzuki, *J. Pharm. Soc. Japan* **56** (1936), 841.

⁴ *J. Pharm. Soc. Japan* **57** (1937), 77. *Chem. Zentr.* II (1937), 2082.

⁵ *J. Pharm. Soc. Japan* **446** (1919), 263.

⁶ *Ber.* **69B** (1936), 2464. See Suzuki, *J. Pharm. Soc. Japan* **56** (1936), 841.

⁷ *J. Pharm. Soc. Japan* **446** (1919), 263.

⁸ *Ber.* **69B** (1936), 2463.

“Carlina Oxide”

C₁₃H₁₀O

Mol. Weight 182.21

Benzyl-2-furylacetylene

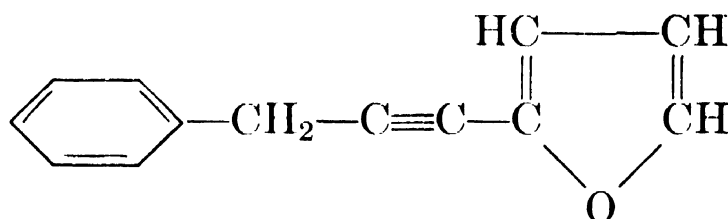

Semmler and collaborators ¹ showed that “carlina oxide” is not an oxide but a furyl derivative. The above formula of “carlina oxide” was suggested by Gilman, Van Ess and Burtner.²

Occurrence.—“Carlina oxide” is the main constituent of oil of carline thistle, derived from the roots of *Carlina acaulis* L.

Isolation.—By fractional distillation.

Identification.—On reduction with metallic sodium and alcohol, “carlina oxide” yields 1-phenyl-3- α -furylpropane. Gilman, Van Ess and Burtner ³ identified this reduction product as α -(γ -phenylpropyl)- α' -furylmercuric chloride C₆H₅(CH₂)₃·C₄H₂OHgCl; *m.* 94°–95°.

Gildemeister and Hoffmann ⁴ reported that on treatment with potassium permanganate “carlina oxide” is quantitatively oxidized to benzoic acid.

Properties.—The following properties have been reported by Gildemeister and Hoffmann:⁵

b_{20}	167°–168°	α_D	$\pm 0^\circ$
d_{17}^{17}	1.066	n_D	1.586

On ozonolysis "carlina oxide," according to Gilman, Van Ess and Burtner,⁶ yields phenylacetic acid.

"Carlina oxide" was synthesized by Pfau, Pictet, Plattner and Susz,⁷ and by Paul.⁸

Use.—"Carlina oxide" is not used in our industries.

¹ *Ber.* **39** (1906), 726; **42** (1909), 2355.

² *J. Am. Chem. Soc.* **55** (1933), 3461.

³ *Ibid.*

⁴ "Die Ätherischen Öle," 3d Ed., Vol. I, 661.

⁵ *Ibid.*

⁶ *J. Am. Chem. Soc.* **55** (1933), 3461.

⁷ *Helv. Chim. Acta* **18** (1935), 935.

⁸ *Compt. rend.* **202** (1936), 854.

Clausenan

Rao and Subramaniam¹ first found in the oil derived from the leaves of *Clausena willdenowii* (fam. *Rutaceae*) as main constituents three substances containing the furan ring, viz., α -clausenan C₁₀H₁₂O, di- α -clausenan C₂₀H₂₄O₂, and β -clausenan C₁₀H₁₄O.

In a subsequent investigation these authors² isolated γ -clausenan from the same botanical but originating from a different locality. However, in this variety, the α - isomer was absent. The γ - compound has the odor of unripe mangoes; its formula has been reported as C₁₀H₁₂O.

α -Clausenan is a colorless liquid of lemon-like odor having these properties:

b ₆₈₄	178°
d ₃₀ ³⁰	0.912
n _D ³⁰	1.4752

The α - compound yields an adduct with maleic anhydride m. 85° (C₁₄H₁₄O₄); the hydrated dibasic acid derived therefrom melts at 98° (C₁₄H₁₆O₅·9H₂O).

Di- α -clausenan is a light yellow viscous liquid, apparently a polymeride of α -clausenan, which readily oxidizes and shows the color reaction of Liebermann. H₄Fe(CN)₆ and H₃Fe(CN)₆ can be used for the purification and estimation of α -clausenan.

Pure β -clausenan has these properties:

b ₅₀	96°-97°	[α] _D ³⁰	+3° 0'
d ₃₀ ³⁰	0.8805	n _D ³⁰	1.4681
d ₄ ³⁰	0.8768		

The acetate derived therefrom has been reported as b₃₂ 105°, d₃₀³⁰ 0.9481, and n_D³⁰ 1.4672.

The γ - isomer does not react with $\text{H}_4\text{Fe}(\text{CN})_6$ and yields a tetrahydro derivative. It is described as follows:

b_{50}	$103^\circ\text{--}104^\circ$	$[\alpha]_{\text{D}}^{30}$	± 0
d_{30}^{30}	0.9089	n_{D}^{30}	1.4739

¹ *Proc. Indian Acad. Sci. A1* (1934), 189. *Chem. Abstracts* **29** (1935), 1209. *Proc. Indian Acad. Sci. A2* (1935), 574. *Chem. Abstracts* **30** (1936), 2563.

² *Proc. Indian Acad. Sci. 3A* (1936), 31.

XI. OXIDES

Linaloöl Monoxide

$C_{10}H_{18}O_2$

Mol. Weight 170.24

2,3-Epoxy-2,6-dimethyl-7-octen-6-ol. Epoxylinaloöl

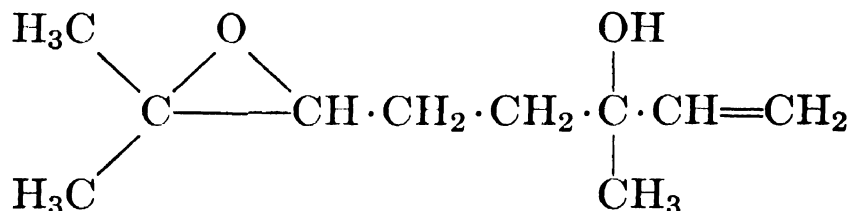

Occurrence.—Schimmel & Co.¹ first observed this monoxide in Mexican linaloe oil where it probably is formed by aerial oxidation of linaloöl while still in the tree. Naves² found that epoxylinaloöl occurs free or as ester in oil of lavandin, free in oil of *shiu*, the content ranging from 0.5 to 4.2 per cent. The structural formula of this oxide originally postulated by Schimmel & Co. was recently modified by Naves and Bachmann³ who found it to be 2,3-epoxy-2,6-dimethyl-7-octen-6-ol.

Isolation.—According to Naves,⁴ the acetate of epoxylinaloöl is separated quantitatively from the acetates of accompanying alcohols by the preparation of its hydroferrocyanic acid complex $C_{12}H_{20}O_3, H_4[Fe(CN)_2]$.

Identification.—By determination of the physicochemical properties. After months of standing with phenylisocyanate, natural linaloöl monoxide forms a phenylurethane m. 59° – 60° , from (1) petroleum ether and (2) alcohol. The acetate of this oxide: b_4 60° – 65° , and the benzoate: b_{3-4} 157° – 160° .

Properties.—Linaloöl monoxide is an oil possessing a musty odor reminiscent of both camphor and fenchyl alcohol. Schimmel & Co.⁵ reported these properties:

b.	193°–194°	d ₁₅ ¹⁵	0.9431–0.9442
b ₆₋₇	71°–73.5°	α _D	–5° 25' to –5° 46'
b ₄	63°–65°	n _D ²⁰	1.45191–1.45221

Naves and Bachmann⁶ found the following properties for epoxylinaloöl:

b _{3.5}	53°–53.5°	[α] _D	–5° 51'
d ₄ ²⁰	0.9439	n _D ²⁰	1.45225

Use.—As such, this oxide is not used in our industries.

¹ *Ber. Schimmel & Co.*, Oct. (1912), 80.

² *Helv. Chim. Acta* **28** (1945), 1231.

³ *Ibid.* 1227.

⁴ *Ibid.* 1231.

⁵ *Ber. Schimmel & Co.*, Oct. (1912), 80.

⁶ *Helv. Chim. Acta* **28** (1945), 1227.

1,8-Cineole

("Eucalyptol")

 $C_{10}H_{18}O$

Mol. Weight 154.24

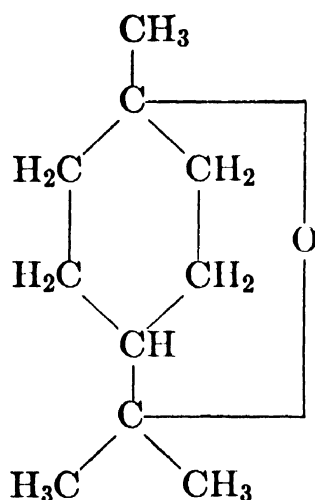
1,8-Oxido-*p*-menthane. 1,8-Epoxy-*p*-menthane. "Cajuputol"

Occurrence.—1,8-Cineole occurs in numerous essential oils, in fact Ganapathi¹ has pointed out in his survey of natural products that cineole occurs in 260 volatile oils being exceeded in numbers only by α -pinene. In several of these it forms the main constituent. Thus the oils from certain eucalyptus species contain from 30–70 per cent 1,8-cineole; in one, the *Eucalyptus polybractea*, a content of 92 per cent is reported by Berry and Swanson;² in cajuput oil, about 40 per cent; niaouli oil, 35–60 per cent; laurel leaf oil, about 50 per cent. Cineole occurs also in oil of cardamom, ginger root, spike lavender, rosemary, certain types of *Ocimum*, *Artemesia* and *Alpina*, and in many other essential oils.

Isolation.—1,8-Cineole can be separated from essential oils by several methods:

(1) If the oil contains a high percentage of cineole, this anhydride may be isolated by first fractionating the oil and by cooling the fraction b. 170° – 180° to a low temperature. Cineole can thus be obtained in crystalline and almost pure form.

(2) 1,8-Cineole forms addition compounds with halogen acids which can be decomposed by the action of water. With hydrogen chloride in ligroine solution, cineole yields the addition compound $(C_{10}H_{18}O)_2 \cdot HCl$. This addition compound is of limited use, however, as it is soluble in several constituents of essential oils. The hydrobromide, $C_{10}H_{18}O \cdot HBr$, prepared from hydrogen bromide and cineole, is but sparingly soluble in organics and thus serves to identify this oxide in mixtures. For the preparation of the hydrogen bromide compound Wallach et al.³ recommended diluting the fraction b. 175° – 180° of the essential oil in question with an equal volume of petroleum ether, and saturating the solution at low temperature with dry hydrogen bromide. The crystalline white precipitation of the addition compound $C_{10}H_{18}O \cdot HBr$ is filtered off under suction, and washed with petroleum ether. From this compound m. 56° – 57° cineole may be regenerated by the action of water.

The nature of these addition products has been studied by Müller⁴ who found them to be solvates $C_{10}H_{18}O \cdots HX$, not oxonium salts $[C_{10}H_{18}OH]X$.

(3) With resorcinol, 1,8-cineole forms an addition compound $(C_{10}H_{18}O)_2 \cdot C_6H_6O_2$,

m. 80° – 85° , from which cineole can be regenerated. This reaction may serve for the separation of cineole from essential oils, provided the cineole content is sufficiently high; otherwise, the oil must first be fractionated.

For this purpose, according to Gildemeister and Hoffmann,⁵ the cineole-containing fraction is thoroughly mixed with the same or the double volume of a 50% resorcinol solution. Occasionally the addition compound will form only after a few crystals of cineole-resorcinol have been added. After formation, the crystalline mass is filtered off on a suction filter, pressed between filter paper, and decomposed with alkali. The cineole-resorcinol compound crystallizes in the form of needles which are readily soluble in alcohol, ether and benzene, but only sparingly soluble in petroleum ether and water.

Cineole-resorcinol is considerably more stable than the crystalline addition compound of cineole and phosphoric acid $C_{10}H_{18}O \cdot H_3PO_4$, a complex much used in the past for the determination of cineole in essential oils or mixtures, and still employed to isolate this cineole where its 1,4-isomer is a contaminant.⁶ Yet, cineole-resorcinol, too, decomposes on exposure to air, and more readily *in vacuo*, with vaporization of cineole so that only resorcinol remains. Decomposition of the cineole-resorcinol compound takes place also on heating with water or with petroleum ether, even on washing of the compound with water or with petroleum ether. According to Baeyer and Villiger,⁷ cineole-resorcinol may be obtained dry and well crystallized by recrystallization of 1 part resorcinol from 10 parts cineole.

The compound $(C_{10}H_{18}O)_2 \cdot C_6H_6O_2$ possesses a melting point of 80° – 85° (Baeyer and Villiger). Bellucci and Grassi⁸ determined the melting point of $C_{10}H_{18}O \cdot C_6H_6O_2$ as 89° .

The reaction of cineole with resorcinol can be used for the quantitative assay of cineole.⁹

(4) With *o*-cresol, cineole forms an addition compound $C_{10}H_{18}O \cdot C_7H_8O$, f.p. 56.3° (based on a pure *o*-cresol f.p. 30.95° and a cineole of f.p. 1.3°) according to Berry and Swanson,¹⁰ from which compound cineole can be regenerated.

This type of reaction with phenols forms the basis of several industrial methods for the isolation of cineole.^{11,12,13,14} The *o*-cresol compound in particular has been investigated by Cocking,¹⁵ Allan,¹⁶ Penfold and Morrison,¹⁷ Berry,¹⁸ Reclaire and Spoelstra,¹⁹ Sissons,²⁰ Reed,²¹ and Berry and Swanson²² as a method for the quantitative assay of cineole. It is official in the British Pharmacopoeia of 1932.

For the details regarding the quantitative assay of cineole, see Vol. I, Chapter 4, "The Examination and Analysis of Essential Oils, Synthetics, and Isolates," p. 294.

Identification.—1,8-Cineole can be characterized by a number of derivatives, chiefly addition compounds formed with cineole and numerous chemicals:

(1) By the iodol derivative $C_{10}H_{18}O \cdot C_4HI_4N$, m. 112° . According to Hirschsohn²³ this compound is formed readily if a few drops of the oil in question are warmed with a little iodol. In case large quantities of cineole are present the crystalline addition compound will separate quickly. According to Earle,²⁴ a solution of 1 part of cineole in 20 to 30 parts of phellandrene will require a half hour for the addition compound to separate. After recrystallization from alcohol or benzene the compound melts at 112° (Bertram and Walbaum²⁵).

(2) By the addition compound of 1,8-cineole and hydrogen bromide $C_{10}H_{18}O \cdot HBr$, m. 56° – 57° (Wallach and Gildemeister).

(3) By the addition of aromatic hydroxy compounds to cineole.

Those of resorcinol and *o*-cresol have been previously mentioned in connection with isolation and continue to be used widely. Wasicky and Gmach²⁶ prefer the addition complex with resorcinol for identification in histo- and micro-chemical methods. The pure resorcinol $C_{10}H_{18}O \cdot C_6H_6O_2$ solvate melts at 89° (Bellucci and Grassi). The carefully prepared *o*-cresol complex has a f.p. 56.3° (Berry and Swanson). A melting

point of 57° on a product crystallized from petroleum ether has been reported by Potter and Williams,²⁷ and Morgan and Pettet.²⁸ A rather wide selection of these addition products is offered in the summary of Müller,²⁹ and in publications of Dodge,³⁰ and Morgan and Pettet.³¹

(4) On oxidation with hot potassium permanganate 1,8-cineole gives a racemic dibasic acid, viz., cineolic acid C₁₀H₁₆O₅, m. 204°–206° (Rupe and Ronus).³² When digested with acetic anhydride or distilled under reduced pressure, cineolic acid is converted, according to Wallach,³³ into an anhydride m. 77°–78°.

(5) A number of characteristic qualitative color reactions have been developed by Ekkert.³⁴

Properties.—1,8-Cineole is a colorless, syrupy oil with an odor suggestive of camphor, and a pungent taste. The following properties of the inactive liquid from commercial production have been reported by Gildemeister and Hoffmann:³⁵

m.	1.0°–1.5°	d ₁₅ ¹⁵	0.928–0.930
Cong. pt.	+1°	n _D ²⁰	1.454–1.461
b ₇₆₄	176°–177°		
Sol.	Soluble in 12 vol. of 50% alcohol, in 1.5 to 2 vol. of 70% alcohol. Sparingly soluble in cold water, even less soluble in warm water		

Berry and Swanson³⁶ indicated the following properties for carefully purified cineole:

f.p.	+1.3°	α _D	±0°
d _{15.5} ^{15.5}	0.9294	n _D ²⁰	1.4575

1,8-Cineole is quite stable and can be distilled over metallic sodium without undergoing any change. As pointed out, cineole readily forms addition compounds. It is not attacked by the ordinary reducing agents.

Use.—Cineole is used very widely in pharmaceutical preparations, applied internally and locally. Internally, cineole serves as a stimulating expectorant in cases of chronic bronchitis, etc. Locally, cineole is a mild anesthetic and antiseptic in the treatment of inflammatory conditions. Cineole, furthermore, is used in room sprays, lotions, and in all kinds of cosmetic preparations, etc.

¹ *Current Science* **6** (1937), 19.

² *J. Proc. Roy. Soc. N. S. Wales* **75** (1941), 65.

³ *Liebigs Ann.* **225** (1884), 294; **246** (1888), 280.

⁴ *Riechstoff Ind.* **4** (1929), 143, 158.

⁵ "Die Ätherischen Öle," 3d Ed., Vol. I, 665.

⁶ Rheinische Kampfer Fabrik Ges. British Patent No. 317,757, Aug 21, 1928.

⁷ *Ber.* **35** (1902), 1209.

⁸ *Gazz. chim. ital.* **43**, No. 2 (1913), 725.

⁹ Gildemeister and Hoffmann, "Die Ätherischen Öle," 3d Ed., Vol. I, 767.

- ¹⁰ *Perfumery Essential Oil Record* **24** (1933), 224.
- ¹¹ Rheinische Kampfer Fabrik Ges. German Patent No. 585,162, Sept. 29, 1933.
- ¹² Newport Ind., U. S. Patent No. 2,090,620, Aug. 24, 1937.
- ¹³ Hercules Powder Co., U. S. Patent No. 2,315,986, April 6, 1943.
- ¹⁴ Hercules Powder Co., U. S. Patent No. 2,353,319, July 11, 1944.
- ¹⁵ *Pharm. J.* **105** (1920), 81. *Perfumery Essential Oil Record* **11** (1920), 281; **15** (1924), 10; **18** (1927), 165, 254.
- ¹⁶ *Chemist Druggist* **107** (1927), 19, 515. *Analyst* **52** (1927), 276.
- ¹⁷ *J. Proc. Roy. Soc. N. S. Wales* **62** (1928), 72. *Perfumery Essential Oil Record* **19** (1928), 468.
- ¹⁸ *Australasian J. Pharm.* (1929), 203. *Chem. Abstracts* **23** (1929), 3302.
- ¹⁹ *Ber. Afdeel. Handelsmuseum Ver. Koloniaal Inst.*, No. 54 (1930), 8. *Chem. Abstracts* **25** (1931), 2521.
- ²⁰ *Proc. Soc. Chem. Ind., Victoria* **32** (1932), 681.
- ²¹ *Perfumery Essential Oil Record* **23** (1932), 340.
- ²² *Australian-New Zealand Assocn. Advancement Sci. Sydney Meeting*, Aug. (1932), 15. *Perfumery Essential Oil Record* **23** (1932), 371; **24** (1933), 224.
- ²³ *Pharm. Z. Russland* **32** (1893), 49, 67. Cf. Gildemeister and Hoffmann, "Die Ätherischen Öle," 3d Ed., Vol. I, 665.
- ²⁴ *J. Soc. Chem. Ind.* **37** (1918), 274T.
- ²⁵ *Arch. Pharm.* **235** (1897), 178.
- ²⁶ *Scientia Pharm.* **5** (1934), 113.
- ²⁷ *J. Soc. Chem. Ind.* **51** (1932), 59T.
- ²⁸ *Ibid.* **54** (1935), 20T.
- ²⁹ *Riechstoff Ind.* **4** (1929), 143.
- ³⁰ *J. Am. Pharm. Assocn.* **22** (1933), 20.
- ³¹ *J. Soc. Chem. Ind.* **54** (1935), 22T.
- ³² *Ber.* **33** (1900), 3544. See also Rupe and Hirschmann, *Helv. Chim. Acta* **16** (1933), 509.
- ³³ *Liebigs Ann.* **258** (1890), 319.
- ³⁴ *Pharm. Zentralhalle* **75** (1934), 145.
- ³⁵ "Die Ätherischen Öle," 3d Ed., Vol. I, 663.
- ³⁶ *Perfumery Essential Oil Record* **23** (1932), 373.

SUGGESTED ADDITIONAL LITERATURE

Tessaku Ikeda and Shosaburo Takeda, "A New Method for the Determination of Linalool, Cineole and Terpeneol," *J. Chem. Soc. Japan* **57** (1936), 442. *Chem. Abstracts* **30** (1936), 5907.

H. Rheinboldt and H. Stettiner, "The Power of Cineole to Combine with Organic Iodides," *Bol. facultade filosofia, cienc. letras, Univ. São Paulo* **14**, *Quimica*, No. 1 (1942), 15. *Chem. Abstracts* **40** (1946), 1474.

1,4-Cineole

 $C_{10}H_{18}O$

Mol. Weight 154.24

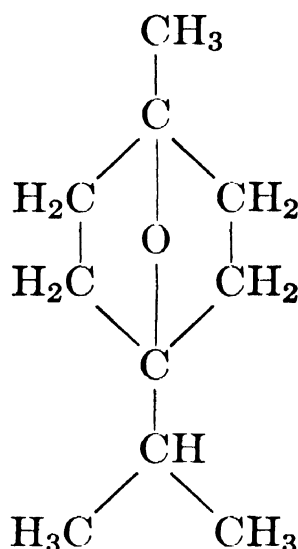
1,4-Oxido-*p*-menthane. 1,4-Epoxy-*p*-menthane

Occurrence.—This oxide is not easily identified. Thus its occurrence in essential oils was not established until Rao, Shintre and Simonsen¹ identified it in oil of cubeb.

Isolation.—By fractional distillation, separating the fraction b_{100} 109°–112°.

Identification.—(1) On treatment with hydrogen chloride in glacial acetic acid solution, 1,4-cineole yields terpinene dihydrochloride m. 52°.

(2) When treated with hydrogen bromide in petroleum ether, 1,4-cineole gives no precipitate, but is slowly converted into terpinene dihydrobromide m. 58°–59°.

(3) On oxidation with potassium permanganate even in a hot solution, 1,4-cineole, according to Wallach,² only slowly yields among other products a sparingly soluble acid m. 157°, the constitution of which remains unknown.

Properties.—The properties of 1,4-cineole differ considerably from those of the 1,8-isomer. 1,4-Cineole possesses a camphoraceous odor; contrary to 1,8-cineole, it does not congeal. Wallach and co-workers^{2,3} recorded these properties:

b.	172°–173° ^{2,3}	n_D^{19}	1.4479 ²
d_{18}	0.9010 ²	n_D	1.4485 ³

Use.—1,4-Cineole has not found any noteworthy use in the perfume and flavor industries.

¹ *J. Soc. Chem. Ind.* **47** (1928), 92T.

² *Liebigs Ann.* **392** (1912), 62.

³ *Ibid.* **356** (1907), 204.

Pinol

C₁₀H₁₆O

Mol. Weight 152.23

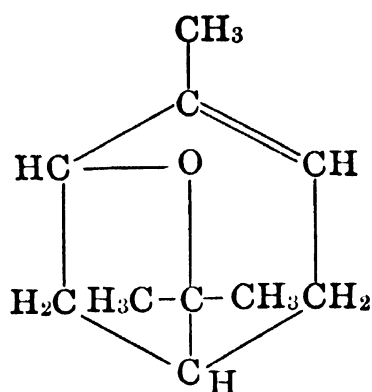

Occurrence.—This oxide has not been found to occur in essential oils. It is a by-product in the preparation of pinene nitrosochloride; it also forms on heating pinol hydrate (sobrerol), etc.

Identification.—(1) On treatment with bromine, pinol yields a crystalline dibromide, viz., pinol dibromide m. 94°.

(2) According to Wallach et al.,¹ pinol readily forms a bimolecular nitrosochloride m. 116°–120° (fast heating), which on storage passes into the monomolecular form m. 131°.

From the nitrosochloride several nitrolamines can be prepared, for example, the nitrolpiperidine m. 154°, or the nitrolbenzylamine m. 135°–136°.

Properties.—Pinol is an oil possessing a pronounced camphoraceous odor.

Certain characteristics of the active as well as the inactive pinol have been reported but the work still leaves much to be desired as regards complete description of samples examined. Wagner and Slawinski² gave a meager amount of information on a product that was apparently the *d*-isomer (b_{752} 183°–184°, b_{22} 77°); while Delépine, Horeau and Grandperrin-Harispe³ contributed a few properties on a crude *l*-form ($[\alpha]_D$ –34° 48', n_D^{18} 1.473).

The following range of properties appears to describe the inactive pinol:

b.	183°–184° ¹	d_{20}	0.9420 ⁴
b_{14}	76°–77° ²		0.9530 ¹
		n_D^{20}	1.46949 ¹
			1.47145 ⁴

Use.—Pinol is not used in our industries.

¹ *Liebigs Ann.* **253** (1889), 261; **306** (1899), 278.

² *Ber.* **32** (1899), 2071; **27** (1894), 1644.

³ *Ann. chim.* [11], **18** (1943), 265.

⁴ Wallach, *Liebigs Ann.* **281** (1894), 148.

l- Δ^3 -Caren-5,6-epoxideC₁₀H₁₄O

Mol. Weight 150.21

Epoxy-carene

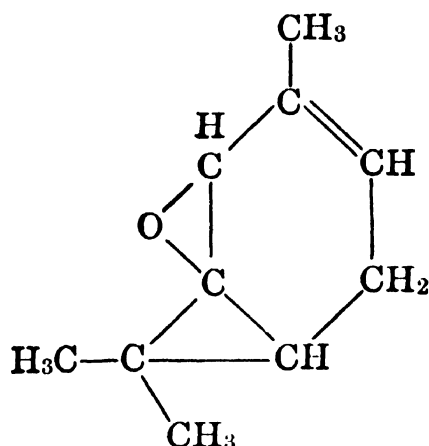

Occurrence.—The *l*- modification of this oxide was identified by Penfold, Ramage and Simonsen¹ as main constituent in oil of *Zieria smithii*, in the fraction b₁₇ 88°–90°.

Isolation.—By fractional distillation, separating the fraction b₁₂ 88°–90°, and removing traces of alcohol with 3,5-dinitrobenzoylchloride.

Identification.—(1) The methods of identification are based on the conversion of the epoxide into ketones by isomerization on heating. The semicarbazone which forms in five days, after crystallization from methyl alcohol, melts at 192°, [α]₅₄₆₁ –95° (in pyridine, *c* = 4.55). Repeated fractional crystallization gave one fraction in feathery needles m. 192°–194°, [α]₅₄₆₁ –70° (in pyridine, *c* = 3.46); another in well-formed prisms m. 199°.

(2) When treated in the cold for five days with an aqueous solution of 2,4-dinitrophenylhydrazine sulfate, *l*- Δ^3 -caren-5,6-epoxide yields a 2,4-dinitrophenylhydrazone mixture m. 145°–147° which in alcoholic solution is separable into the sparingly soluble α - isomer m. 192°–193° and the β - product m. 165°–166°.

Properties.—*l*- Δ^3 -Caren-5,6-epoxide is a mobile oil of very pleasant odor. The afore-named authors reported these properties:

b ₁₄	83°–85°	n _D ²⁵	1.4729
d ₂₅ ²⁵	0.9454	[R _L] _D	Obs. 44.63
[α] ₅₄₆₁	–88° 0'		Calc. 43.63

Use.—This oxide is not used in our industries.

¹ *J. Chem. Soc.* (1939), 1496.

Ascaridole

 $C_{10}H_{16}O_2$

Mol. Weight 168.23

2-*p*-Menthene-1,4-dioxide. 1-Methyl-4-isopropyl-2-cyclohexene-1,4-dioxide.
1,4-Peroxido-2-*p*-menthene

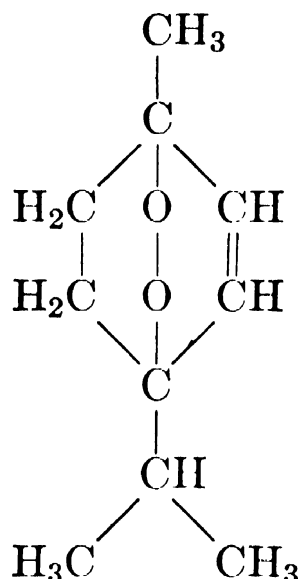

Ascaridole, a powerful anthelmintic, is one of the most interesting compounds occurring in essential oils.

Occurrence.—Ascaridole is the main constituent (65–70 per cent) of American wormseed oil (*Chenopodium ambrosioides* var. *anthelminticum* L.).

Isolation.—By repeated fractional distillation of wormseed oil *in vacuo*, using the fraction b₈ 95°–98°. Paget¹ likewise prepared a purified sample of this dioxide by crystallization at –20°.

Identification.—Ascaridole does not yield any crystalline derivatives; it must, therefore, be characterized by either of the following reactions:

(1) On oxidation with ferrous sulfate, ascaridole yields, aside from some isopropyl alcohol, mainly a glycol which is not volatile with steam, viz., ascaridole glycol $C_{10}H_{18}O_3$, m. 62.5°–64°, b. 271°–272°, d_{20}^{20} 1.0981, n_D^{20} 1.4796, $[\alpha]_D \pm 0^\circ$. This glycol can be characterized by its monobenzoate m. 136°–137°, and by its dibenzoate m. 116.5°–117.5°.

(2) On reduction with hydrogen, using palladium as catalyst, ascaridole yields, according to Wallach,² a terpinene-terpin (1,4-terpin) $C_{10}H_{18}(OH)_2$, m. 116°–117°. This 1,4-terpin is optically inactive, and not identical with 1,8-terpin although they have similar melting points. More recently Paget identified *cis*-1,4-terpin by the catalytic hydrogenation of ascaridole and prepared in 95% ethyl alcohol the mono-*p*-nitrobenzoate m. 117° and the di-*p*-nitrobenzoate m. 172° from this terpenic alcohol.

Quantitative Determination.—Regarding the quantitative determination of ascaridole, see Vol. I, Chapter 4, “The Examination and Analysis of Essential Oils, Synthetics, and Isolates.” See also “Determination of Ascaridole in *Chenopodium* Oil,” by Cocking and Hymas.³

Properties.—Ascaridole is a somewhat viscid oil possessing a very peculiar, most disagreeable odor and flavor.

The following properties have been reported by Nelson,⁴ Schimmel & Co.,⁵ and Paget:⁶

m.	2° ⁶	α_D	-4° 14' ⁵
b ₂₀	112°-115° ⁶	α_D^{20}	+0° 42' ⁴
b ₈	96°-97° ⁴	$[\alpha]_D$	-2° 18' ⁶
b ₄₋₅	83° ⁵	n_D^{20}	1.4769 ⁵
d ₂₀ ²⁰	0.9985 ⁴		
d ₁₈ ¹⁸	1.0074 ⁶		
d ₁₅ ¹⁵	1.0079 ⁵		

Ascaridole cannot be distilled at atmospheric pressure; when heated to 130°-150°, it decomposes with explosive violence. When submitted to careful heating to 150° in an inert solvent, ascaridole is isomerized to ascaridole glycol anhydride b₂₀ 122°-125°, d₁₅ 1.026, $[\alpha]_D$ -0° 43'. From this anhydride, ascaridole glycol can be prepared by hydration with dilute sulfuric acid, according to Henry and Paget.⁷

Ascaridole is decomposed with explosive violence also by the action of sulfuric, hydrochloric, nitric and phosphoric acids.

Use.—Ascaridole is a powerful anthelmintic and serves in many medicinal and veterinary preparations.

¹ *J. Chem. Soc.* (1938), 829.

² *Liebigs Ann.* **392** (1912), 59.

³ *Analyst* **55** (1930), 180. *Chem. Abstracts* **24** (1930), 2833.

⁴ *J. Am. Chem. Soc.* **33** (1911), 1406.

⁵ *Ber. Schimmel & Co.*, April (1908), 113. *Chem. Zentr.* I (1908), 1839.

⁶ *J. Chem. Soc.* (1938), 829.

⁷ *J. Chem. Soc.* **119** (1921), 1722.

SUGGESTED ADDITIONAL LITERATURE

A. Halpern, "Ascaridole in Oil of Chenopodium," *J. Amer. Pharm. Assocn.* **37** (1948), 161.

Caryophyllene Oxide

C₁₅H₂₄O

Mol. Weight 220.34

Epoxy-dihydrocaryophyllene

The structural formula of caryophyllene oxide, like that of its parent sesquiterpene, caryophyllene, has not yet been fully established. In a recent publication Treibs¹ suggested that in the synthesis of caryophyllene oxide the oxygen attacks the cyclic double bond of the caryophyllene molecule. Treibs² readily prepared caryophyllene oxide in 80-85 per cent yield by oxidizing caryophyllene with hydrogen peroxide, using pervanadic acid as a catalyzing agent.

Occurrence.—According to Treibs,³ caryophyllene oxide is of special interest from the biological point of view, as it occurs in several essential oils which contain caryophyllene. This sesquiterpene is probably the parent substance of the oxide. By proper treatment (see below) the oxide can be isolated in crystalline form from the sesquiterpene fraction of clove oil. The crystalline sesquiterpene oxide isolated by Seidel, Müller and Schinz⁴ a few years ago, from oil of lavender, is undoubtedly identical with caryophyllene oxide. This compound probably occurs also in other essential oils which contain caryophyllene. Analogous sesquiterpene oxides have not been observed in, or isolated from, essential oils probably for the simple reason that no adequate characteristic derivatives are known.

Isolation.—Treibs⁵ suggested the following method for the isolation of natural caryophyllene oxide from oil of cloves:

Eliminate the main portion of the hydrocarbons from 1 kg. of the sesquiterpene fraction, of clove oil, b₈ 100°–170°, by fractional distillation *in vacuo*, and by shaking with methyl alcohol containing 2% water. From the soluble portions separate the alcohols via the boric esters, and then remove the ketones via the semicarbazones. The portion that is separated from the semicarbazones by steam distillation is heated with sodium and fractionated in a Widmer flask at a pressure of 7 mm. The fraction b₇ 138°–140° will crystallize after inoculation with solid caryophyllene oxide. After drying on a clay plate and recrystallization from methyl alcohol the caryophyllene oxide will melt at 64°.

Identification.—By determination of the physicochemical properties.

Properties.—Treibs⁶ reported these properties of caryophyllene oxide:

m.	64°	α_D^{20}	−68° 0′
d_4^{20}	0.9658	n_D^{20}	1.4958

The oxide is stable against oxidizing agents. It reacts readily with Grignard's reagent.

Naves⁷ investigated a concentrated extract of clove buds (benzene as solvent) for the presence of caryophyllene, and found that the extract did not contain any caryophyllene, but epoxy-dihydrocaryophyllene (the caryophyllene oxide of Treibs). Steam distilling the clove buds after they had been extracted, Naves obtained a volatile oil, composed chiefly of caryophyllene. The latter, therefore, is not a natural, biological product of the clove buds, but must have originated under the influence of boiling water.

The epoxy-dihydrocaryophyllene observed by Naves in the extract of clove buds had these properties:

m.	63°–64°	$[\alpha]_D$	−70° 2′
b _{1.8}	114°–117°	n_D^{20}	1.49564
d_4^{20}	0.966		

Use.—Caryophyllene oxide, as such, is not used in our industries.

¹ *Chem. Ber.* **80**, No. 1 (1947), 56.

² *Ibid.* Cf. *Ber.* **72** (1939), 1194. *Z. angew. Chem.* **52** (1939), 698.

³ *Chem. Ber.* **80**, No. 1 (1947), 56.

⁴ *Helv. Chim. Acta* **27** (1944), 738.

⁵ *Chem. Ber.* **80**, No. 1 (1947), 56.

⁶ *Ibid.*

⁷ *Helv. Chim. Acta* **31** (1948), 378.

Dicitronelloxide

$C_{20}H_{34}O$

Mol. Weight 290.47

Occurrence.—This oxide was found by Spornitz¹ in the high boiling fractions of Java citronella oil.

Isolation.—By fractional distillation.

Identification.—On passing a current of dry hydrogen chloride gas through an ethereal solution of dicitronelloxide, a monohydrochloride m. 107.5° is obtained.

Properties.—Dicitronelloxide is a viscid oil of faint odor. Spornitz² reported these properties:

b_{12}	182°–183°	α_D	–4° 0'
d_{20}^{20}	0.9199	n_D	1.49179

Quite probably this compound is closely related to others of like properties obtained by the action of dehydrating agents upon citronellal (or linaloöl) [cf. Barbier and Leser,³ Semmler and Jonas,⁴ Ono and Takeda,⁵ Kimura,⁶ Meyer,⁷ and Horiuti, Otuki and Okuda⁸].

There are indications that this oxide is one of the ethers of pulegol.

Use.—Dicitronelloxide, as such, has not attained any importance, but the high boiling fractions of Java citronella oil containing this oxide are widely used as fixatives in perfumes, cosmetics, soaps, and compounds serving for the scenting of technical products.

¹ *Ber.* **47** (1914), 2478.

² *Ibid.*

³ *Compt. rend.* **124** (1897), 1310.

⁴ *Ber.* **47** (1914), 2079.

⁵ *Bull. Chem. Soc. Japan* **2** (1927), 16. *Chem. Zentr.* I (1927), 2071.

⁶ *J. Chem. Soc. Japan* **53** (1932), 497. *Bull. Chem. Soc. Japan* **10** (1935), 330.

⁷ *Deut. Parfümerieztg.* **17** (1931), 434. *Chimie & industrie* **27** (1932), 879.

⁸ *Bull. Chem. Soc. Japan* **14** (1939), 501.

XII. COMPOUNDS CONTAINING NITROGEN AND SULFUR

Introduction.—Plant materials which contain substantial quantities of albuminous or related matter, on distillation, often yield nitrogenous or sulphurous compounds. This holds true of fresh herbs, and particularly of seeds. The more volatile compounds such as ammonia, trimethylamine, hydrocyanic acid and hydrogen sulfide escape in vapor form during distillation. Small quantities may dissolve in the distillation waters or, according to Gildemeister and Hoffmann,¹ may react with other constituents of the essential oil. Development of ammonia takes place during the distillation, for example, of pepper, cubebs, pimenta, etc., while bases of narcotic odor have been observed in the case of caraway and other seeds of the family *Umbelliferae*.

Nitrogen-containing esters (methyl anthranilate, dimethyl anthranilate, and damascenine) are described under "Esters."

¹ "Die Ätherischen Öle," 3d Ed., Vol. I, 667.

A. CYANIDES

Hydrocyanic Acid

CHN

Mol. Weight 27.03

Prussic acid. Hydrogen cyanide. Formonitrile

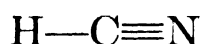

Occurrence.—Hydrocyanic acid occurs in numerous plants. According to Rosenthaler,¹ this acid seems to play a considerable role in the synthesis or in the degradation of albuminous matter. In volatile oils hydrocyanic acid is frequently associated with benzaldehyde, as, for example, in bitter almond oil or in the volatile oil derived from crushed peach or apricot kernels. In these cases benzaldehyde and hydrocyanic acid exist in the plant material originally not as such but in the form of a glucoside as, for instance, amygdalin, accompanied by the enzyme emulsin. After reduction of the cell walls by crushing, milling, etc., and on digestion with luke-warm water, the enzyme can get in contact with the glucoside, splitting it into glucose, benzaldehyde, and hydrocyanic acid

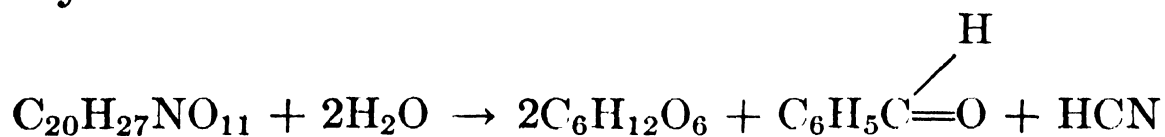

Many similar glucosides yielding hydrocyanic acid occur in nature—for instance, prunasin, sambunigrin, prulaurasin, gynocardin, laurocerasin, etc.—

but space does not permit even citing the voluminous literature dealing with this topic.

Isolation.—Hydrocyanic acid can be isolated from an essential oil by fractional distillation, a rather dangerous procedure because of the high toxicity of this gaseous substance. In most cases it will, therefore, be sufficient merely to identify hydrocyanic acid in a volatile oil.

Identification.—There exist two well-known qualitative tests for the identification of hydrocyanic acid:

(1) The Prussian Blue Test:

Thoroughly crush the plant material, macerate it with luke-warm water, acidify with dilute sulfuric acid, and steam distill the mash for several hours. Shake a small quantity of the distillate with a few drops of sodium hydroxide solution, add a few drops of ferrous sulfate containing ferric oxide, again shake thoroughly and acidify with dilute hydrochloric acid. After the precipitation of ferriferrous oxide (Fe_3O_4) has dissolved, a characteristic precipitate of Prussian Blue will be noticed, if the mixture to be investigated contains hydrocyanic acid.

(2) The Sulfocyanate Test:

Add 3 drops of potassium hydroxide solution and 10 drops of yellow ammonium sulfide solution to a few cc. of a dilute aqueous solution of the substance to be investigated. Evaporate to dryness on a water bath, dissolve the residue in 5 cc. of water, filter to remove the sulfur, and add 1 drop of ferric chloride solution. A blood red color will appear if hydrocyanic acid is present.

The techniques, however, for detection, identification, and analysis of hydrocyanic acid are so varied and numerous that the worker should consult the literature in connection with the demands of his specialized problem and the facilities of the laboratories rather than heed any generalized recommendation in this connection.

Properties.—Hydrocyanic acid at room temperature is a gas of characteristic odor typical of bitter almonds. The acid is highly poisonous and should be smelled only in extreme dilution. Miscible with water or alcohol, easily soluble in ether. Hydrocyanic acid is a very weak acid which reddens litmus paper only faintly. It burns with a violet flame.

Tromp,² Coates, Hinkel and Angel,³ and Peters⁴ reported these properties of hydrocyanic acid which have not been materially altered in the course of numerous subsequent investigations.

m.	-14° to -15° ²	d_{20}	0.6874 ⁴
b.	25.7° (corr.) ³	n_D^{20}	1.2619 ⁴

For further data see Beilstein,⁵ U. S. Dispensatory,⁶ and International Critical Tables.

Use.—Because of its great toxicity, hydrocyanic acid cannot be used in any proportion in perfumes or flavors.

¹ *Biochem. Z.* **134** (1923), 215, 225.

² *Rec. trav. chim.* **41** (1922), 286.

³ *J. Chem. Soc.* (1928), 542.

⁴ *Ann. phys.* [4], **86** (1928), 508.

⁵ "Handbuch der Organischen Chemie," Vol. II, p. 35.

⁶ 24th Ed., 1942, 550.

Allyl Cyanide

 C_4H_5N

Mol. Weight 67.09

Vinyl acetonitrile. Crotonic acid nitrile



Occurrence.—Traces of allyl cyanide, according to Gildemeister and Hoffmann,¹ always occur in mustard oils. The presence of larger quantities in a synthetic mustard oil is probably the result of careless manufacturing and due to the degradation of allyl mustard oil $CH_2=CH \cdot CH_2 \cdot N=C=S$.

Isolation.—By fractional distillation.

Identification.—According to Will and Körner,² treatment of allyl cyanide with alcoholic potassium hydroxide yields crotonic acid m. 72° .

Properties.—Will and Körner,³ Rinne and Tollens,⁴ and Bruylants⁵ reported these properties of allyl cyanide:

b.	119° ^{3,5} (corr.)
d_{15}	0.8351 ⁴
n_D^{20}	1.40602 ⁵

Because of its low specific gravity, larger quantities of allyl cyanide in a synthetic mustard oil can be recognized by a corresponding lowering of the specific gravity.

Use.—Allyl cyanide is used very little, if at all, in our industries.

¹ "Die Ätherischen Öle," 3d Ed., Vol. I, 672.

² *Liebigs Ann.* **125** (1863), 273.

³ *Ibid.*, 272.

⁴ *Ibid.* **159** (1871), 105.

⁵ *Bull. soc. chim. Belg.* **31** (1922), 175. *Chem. Abstracts* **17** (1923), 1427.

Benzyl Cyanide

 C_8H_7N

Mol. Weight 117.14

Phenylacetic acid nitrile. Phenacetonitrile

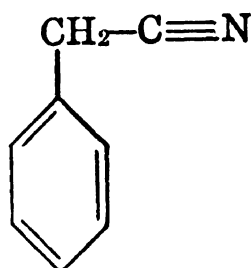

Occurrence.—Benzyl cyanide occurs in oil of *Lepidium sativum*, according to Hofmann,¹ and Gadamer;² probably also in oil of neroli bigarade.

Isolation.—By fractional distillation.

Identification.—(1) Hydrolysis of benzyl cyanide yields phenylacetic acid m. 76°–76.5°, according to Hofmann.³

(2) Weddige⁴ reported that partial hydrolysis of benzyl cyanide gives phenylacetamide m. 154°–155°.

Properties.—Benzyl cyanide is an oil for which Adams and Thal,⁵ von Schneider,⁶ Perkin,⁷ and Walden⁸ reported these properties:

m.	–24.6° ⁶ (corr.)	d_{25}^{25}	1.0154 ⁷
b.	233°–234° ⁷ (corr.)	d_{15}^{15}	1.0214 ⁷
b_{38}	135°–140° ⁵	d_4^4	1.0296 ⁷
b_{10}	115°–120° ⁵	n_D^{25}	1.52105 ⁸

Use.—Benzyl cyanide is used on a very small scale in the compounding of certain floral scents.

¹ *Ber.* **7** (1874), 1293.

² *Arch. Pharm.* **237** (1899), 111.

³ *Ber.* **7** (1874), 518, 1293.

⁴ *J. prakt. Chem.* [2], **7** (1873), 100.

⁵ "Organic Syntheses," Coll. Vol. I, 107 (Wiley, 1941).

⁶ *Z. physik. Chem.* **22** (1897), 233.

⁷ *J. Chem. Soc.* **69** (1896), 1206.

⁸ *Z. physik. Chem.* **59** (1907), 394.

Phenylethyl Cyanide

C_9H_9N

Mol. Weight 131.17

Hydrocinnamic acid nitrile. Phenylpropionic acid nitrile

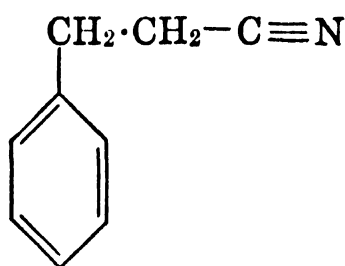

Occurrence.—According to Hofmann¹ this nitrile is the principal constituent of the oil derived from *Nasturtium officinale*.

Isolation.—By fractional distillation.

Identification.—On hydrolysis with dilute alkali, phenylethyl cyanide is converted into phenylpropionic acid (hydrocinnamic acid) m. 47°.

Properties.—The following properties have been reported by Hofmann,² and Grignard, Bellet and Courtot:³

b.	261° ² (corr.)
b_8	114°–118° ³
d_{18}	1.0014 ²

Use.—Phenylethyl cyanide is used on a very small scale in the compounding of certain floral scents.

¹ *Ber.* **7** (1874), 520.

² *Ibid.*

³ *Ann. chim.* [9], **4** (1915), 43.

B. AMINO AND IMINO COMPOUNDS

Indole

C₈H₇N

Mol. Weight 117.14

1-Benzazole. Benzopyrrole

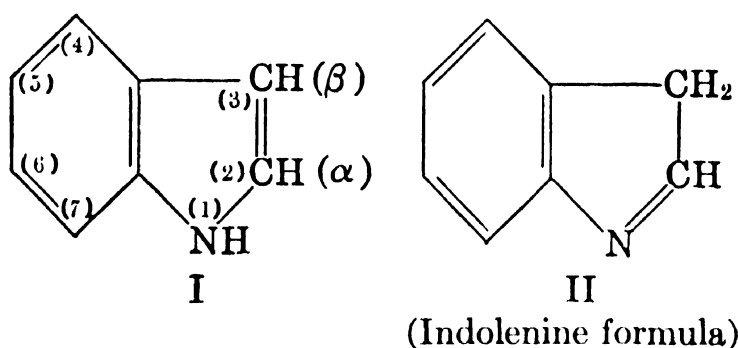

Aside from the formula I, the desmotropic structure II should also be considered. The reactive methylene group contained in II explains the behavior of indole in many reactions.

Occurrence.—Hesse¹ identified indole as an important, although minute constituent of jasmine flower oil. Since then indole has been found also in neroli bigarade oil, and in several other oils derived from flowers, such as jonquil, wallflower, *Robinia pseudacacia*, *Hevea brasiliensis* Muell., *Randia formosana* Jacq., sweet orange, lemon, lime, mandarin, grapefruit, and many all-night blooming varieties of plants. Indole probably occurs in nature as a complex compound which, according to Hesse,² readily decomposes on steam distillation. Moreover, Sack³ noted the occurrence of indole in certain photosensitive flowers, whereas Cerighelli⁴ reported observations, principally in connection with jasmine, to the effect that light often releases indole, hence that the flowers but not the buds yield this nitrogenous compound; furthermore that isolates by *enfleurage* give the highest percentage of yield in indole.

A recent extensive review by van Order and Lindwall⁵ relative to indole also discloses the widespread occurrence of this compound in several natural derivatives other than flower oils.

Isolation, Identification and Quantitative Determination.—Indole is isolated conveniently and determined quantitatively by the preparation of its picrate which crystallizes in the form of long, lustrous, red needles, darkening at 160° and melting to a black liquid at 176°–177°. Hesse⁶ recommended the following procedure:

Add about 10% of picric acid to the oil and heat the mixture to 50°–60° until the precipitate which is first formed on the addition of the picric acid dissolves. On cooling, an abundant precipitate of indole picrate will separate. Add a large excess of petroleum ether and remove by filtration the crystalline precipitate which consists of indole picrate, and the larger quantity of uncombined picric acid. According to the indole picrate content, the color is more or less red. Wash the crystalline precipitate on the filter repeatedly with petroleum ether. Dissolve the crystals thus purified in ammonia or soda solution with gentle heating. Cool the solution, extract it with ether, remove the ether by distillation, and steam distill the residue of the ether solution. The indole present in the flower oil is thereby obtained quantitatively and in an almost pure state.

Numerous other useful methods of assay have been reported but most of these seem to rely upon the Ehrlich reaction with *p*-dimethylamino benzaldehyde. This is the basis of the technique of Seidelin,⁷ the photoelectric method of Allsopp,⁸ and that of King, Flynn and Gowanloch,⁹ and of Jacobs and Pincus.¹⁰

However, Herter and Foster¹¹ prepared the insoluble blue complex of indole with sodium β -naphthoquinone-monosulfonate, the basis of a quantitative method for identifying not only indole, but also for separating this nitrogen compound from skatole.

Numerous colorimetric tests have been reported for indole. According to Frieber,¹² the sodium nitroprusside reaction is the most specific, being given only by the free indole nucleus, while the Ehrlich reaction with *p*-dimethylamino benzaldehyde, the vanillin, and the naphthoquinone reactions require the 3- carbon to be free, and the Salkowski reaction only requires the 2- carbon to be free.

Several workers have considered the numerous color reactions of indole, among them: Nelson,¹³ Fellers and Clough,¹⁴ Czapalla,¹⁵ Salkowski,¹⁶ Cambi et al.,¹⁷ and Blumenthal.¹⁸ From their comments it would appear that a modified Ehrlich test is still preferred; according to Fellers and Clough,¹⁹ it is accurate to about 1 part of indole per 25 millions of solution. These authors describe this test as follows:

Add $\frac{1}{2}$ cc. of *p*-dimethylamino benzaldehyde solution to 5 cc. of a specially prepared extract, followed by 1 cc. of hydrochloric acid (6 parts concentrated acid to 2 parts of water). Place the test tube containing the mixed solutions in boiling water for 20 min., shake vigorously, place in ice water for half a minute and extract with chloroform which will be colored red if indole is present.

A number of pigments and inorganic salts have been reported which possess a limited use either as means of isolation and/or characterization. Franklin²⁰ prepared the Ca, Mg, Ag, Na, and K salts; Mingoia²¹ those of Sb; Saccardi and Giuliani²² salts of Hg. Salts of gold have been described by Saccardi,²³ and a Pd complex by Saccardi and Delavigne.²⁴ Xanthidrol, according to Fearon,²⁵ forms a purple pigment with indole that is specific for this compound.

Indole forms a number of derivatives that may serve for identification. The following should be mentioned:

(1) 1:1-Complex of indole and 4,6-dinitro-*o*-cresol, orange yellow needles, m. 119°–120° (Wain²⁶).

(2) Indole, formaldehyde, and dimethylamine react to form gramine (β -dimethylamino methyl indole) in nearly quantitative yield (Kuhn and Stein²⁷), m. 134°, picrate m. 141.5°. The corresponding β -diethylamino methyl indole melts at 165°, the picrate at 124°, and the β -N-piperidyl methyl indole at 161°.

(3) Trinitroxylyene indole m. 126°, yellow (Skraup and Eisemann²⁸).

(4) Di-indyl m. 302°–303° and monoisnitroso di-indyl m. 253° (Madelung²⁹). Dinitroso di-indyl m. 160°–162°, mononitroso di-indyl m. 121°–122° (Schmitz-Dumont, Hamann and Geller³⁰).

Properties.—Indole crystallizes in the form of white, lustrous leaflets which, on exposure to air and light, soon darken. The odor is very powerful, persistent, disagreeable, fecal, especially if the synthetic product is not sufficiently purified. If pure and strongly diluted, indole has a flowery, heavy odor, no longer disagreeable.

According to Tyson,³¹ Ciamician and Zatti,³² Kryuk,³³ and Gluud,³⁴ indole possesses these properties:

m.	52°–53° ^{31, 32, 33, 34}
b _{762.2}	253°–254° ³² (corr.)
b ₂₇	142°–144° ³¹
b ₁₀	128° ³¹
b ₅	121° ³¹

Indole is volatile with steam, soluble in hot water, easily soluble in alcohol, ether, chloroform or in hydrocarbons. Attention should be given to the fact that indole solutions discolor by turning red.

Use.—Indole is widely used, but in traces only, for the compounding of floral bouquets such as jasmine, orange flower, gardenia, lilac, and in perfumes of heavy, oriental type.

¹ *Ber.* **32** (1899), 2612.

² *Ibid.* **33** (1900), 1587; **34** (1901), 2929; **37** (1904), 1457.

³ *Pharm. Wcekblad* **48** (1911), 306.

⁴ *Compt. rend.* **179** (1924), 1193.

⁵ *Chem. Reviews* **30** (1942), 69.

⁶ *Ber.* **32** (1899), 2612.

⁷ *J. Hyg.* **11** (1911), 118.

⁸ *Biochem. J.* **35** (1941), 965.

⁹ *J. Assocn. Official Agr. Chem.* **28** (1945), 385.

¹⁰ *Science* **102** (1945), 204.

¹¹ *J. Biol. Chem.* **2** (1907), 267.

¹² *Centr. Bakt. Parasitenk.* **87** (1921), 254. *Chem. Abstracts* **17** (1923), 1655.

¹³ *J. Biol. Chem.* **24** (1916), 527.

¹⁴ *J. Bact.* **10** (1925), 105.

¹⁵ *Z. Fleisch- u. Milchhyg.* **50** (1940), 110. *Chem. Abstracts* **34** (1940), 4412.

¹⁶ *Biochem. Z.* **97** (1919), 123; **103** (1920), 185.

¹⁷ *Gazz. chim. ital.* **61** (1931), 11.

¹⁸ *Biochem. Z.* **19** (1909), 521.

¹⁹ *J. Bact.* **10** (1925), 105.

²⁰ *J. Phys. Chem.* **24** (1920), 81.

²¹ *Gazz. chim. ital.* **62** (1932), 343.

²² *Chim. ind. agricolt. biol.* **11** (1935), 219. *Chem. Abstracts* **29** (1935), 7080.

²³ *Ann. chim. applicata* **25** (1935), 157.

²⁴ *Gazz. chim. ital.* **67** (1937), 611.

²⁵ *Analyst* **69** (1944), 122. See also Arreguine, *Rev. univ. nacl. Córdoba (Arg.)* **31** (1944), 1710. *Rev. asoc. bioquím. Argentina* **12** (1945), 3. *Chem. Abstracts* **39** (1945), 3223.

²⁶ *Ann. Applied Biol.* **29** (1942), 301.

²⁷ *Ber.* **70** (1937), 567.

²⁸ *Liebigs Ann.* **449** (1926), 12.

²⁹ *Ibid.* **405** (1914), 58.

³⁰ *Ibid.* **504** (1933), 8.

³¹ "Organic Syntheses," **23** (1943), 42, John Wiley & Sons, New York.

³² *Gazz. chim. ital.* **20** (1890), 86.

³³ *J. Gen. Chem. U.S.S.R.* **10** (1940), 1507. *Chem. Abstracts* **35** (1941), 2518.

³⁴ *Ber.* **48** (1915), 423.

SUGGESTED ADDITIONAL LITERATURE

Joseph Michelman, "Indole Derived from a New Source, Its Uses in Perfumery," *Am. Perfumer* **20** (1925), 141.

H. Stanley Redgrove, "Indole" (review), *Perfumery Essential Oil Record* **20** (1929), 161.

R. E. Duggan and L. W. Strasburger, "Indole in Shrimp," *J. Assocn. Official Agr. Chem.* **29**, No. 2, (1946), 177.

Skatole

C₉H₉N

Mol. Weight 131.17

β -Methylindole. 3-Methylindole

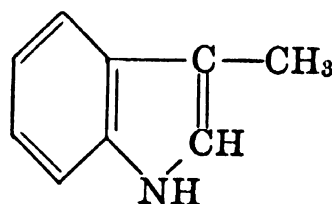

Occurrence.—Walbaum ¹ identified skatole in civet, a glandular excretion of the civet cat; it occurs also in the wood of *Celtis reticulosa*, *C. durandii*, and, according to Sack, ² in the wood of certain *Nectandra* species. The presence of skatole in human excrements as a degradation product of albuminous substances has been known for a long time.

Isolation.—Through the picrate (see "Indole").

Identification.—Skatole can be characterized by several methods.

(1) A pine splinter impregnated with an alcoholic solution of skatole on the addition of concentrated hydrochloric acid will be colored deep red, then violet.

(2) With a solution of *p*-dimethylamino benzaldehyde, skatole develops a blue-violet color, according to Blumenthal. ³

(3) Gnezda ⁴ reports that skatole reacts with potassium ferrocyanide and 98% sulfuric acid in the absence of moisture to give a violet colored solution.

(4) Skatole yields a hydrochloride 2C₉H₉N·HCl, m. 167°–168° (uncorr.), according to Wenzing. ⁵

(5) The picrate crystallizes from benzene in the form of dark red lustrous crystals melting at 172°–173° to a dark brown liquid. Mulliken ⁶ suggested this method:

Suspend 0.05 g. of skatole in 5 cc. of boiling water, add 4 cc. of a saturated picric acid solution and heat to boiling. Set aside until cooled, filter, and wash with 2 cc. of water. Dissolve in 10 cc. of boiling water and allow to stand overnight. Wash the precipitate with 1 cc. of water and dry on a porous plate for 15 min. at 100°. Recrystallize from benzene.

Oddo and Mingoia ⁷ prepared the picrate m. 170°–171° from concentrated solutions of the reactants in alcohol; these authors noted that this derivative is transformed, on exposure to air, to a lemon yellow substance m. 216°–217°.

Properties.—Skatole is a substance of extremely disagreeable, fecal and persistent odor. Skatole crystallizes in the form of white lustrous leaflets.

According to Fischer,⁸ and Cornforth and Robinson,⁹ skatole has these properties:

m.	93° ⁹
b ₇₅₅	265°–266° ⁸

Quite readily volatile with steam, soluble in alcohol, ether, chloroform or benzene. One thousand parts of water dissolve 0.45 part of skatole.

Use.—Skatole is used like indole, in very small amounts, as a modifier and fixative of floral perfume compositions. However, the greatest of care has to be taken in regard to proper dosage as the odor of skatole is even more disagreeable and powerful than that of indole.

¹ *Ber.* **33** (1900), 1903.

² *Pharm. Weekblad* **48** (1911), 307.

³ *Biochem. Z.* **19** (1909), 525.

⁴ *Rad.* **244**, 13. *Chem. Zentr.* I (1935), 3574. *Chem. Abstracts* **30** (1936), 6364.

⁵ *Liebigs Ann.* **239** (1887), 240.

⁶ "Identification of Pure Organic Compounds," Vol. II (1916), 178, John Wiley & Sons, New York.

⁷ *Gazz. chim. ital.* **57** (1927), 484.

⁸ *Liebigs Ann.* **236** (1886), 138.

⁹ *J. Chem. Soc.* (1942), 681.

C. SULFIDES

Introduction.—Sulfides occur quite frequently in plants, probably in the form of glucosides which are decomposed by the process of distillation.

The sulfur may exist in such a combination as hydrogen sulfide H·S·H, as a mercaptan R—S·H, or in oxidized form. In this latter condition it is isolated quite often from a number of oils as the disulfide R—S—S—R readily formed by the action of atmospheric oxygen upon thioalcohols; sometimes the isolation is made via the thioether R—S—R, which results from the reduction of the disulfides. Although the disulfides, water insoluble liquids, are of repugnant odor, the alkyl sulfides, likewise water insoluble liquids, may in some cases possess a not unpleasant smell.

The chemistry of the rather elementary members of this series is so well established that no special attention need be given to them.

A number of well-known reaction products can be used for diagnostic tests on this class of compounds. They are enumerated below:

(1) Sulfonium salts:

(a) Addition compounds with alkyl halides:

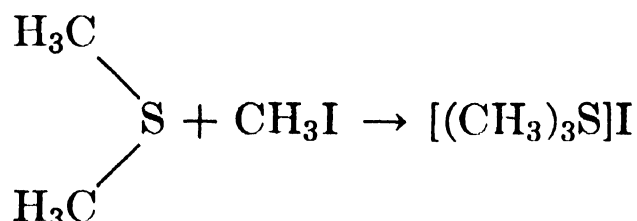

(b) Addition compounds with metallic salts:

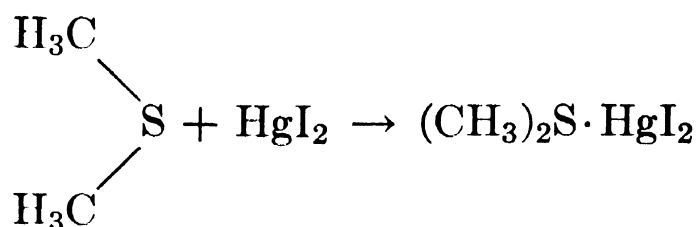

These products crystallize well.

(2) Sulfones:

Strong oxidation (HNO_3 or KMnO_4) of thioethers:

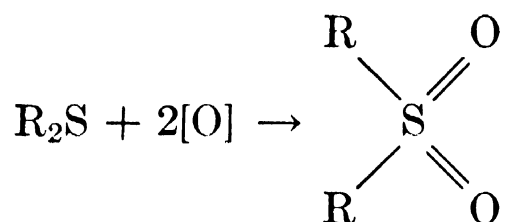

These derivatives are neutral, crystallize well and are very stable to reducing agents.

(3) Sulfonic acids:



These acyclic crystalline compounds are converted through the acid chlorides to nitrogen derivatives with definitive melting points.

Besides these crystalline complexes the worker should consider certain colorimetric methods with these sulfur compounds. Both qualitative and quantitative reactions of this type have been published.

Hydrogen sulfide, H_2S , appears during distillation of certain seeds—*anise* or *caraway*, for example.

Dimethyl sulfide, $(\text{CH}_3)_2\text{S}$, occurs in American peppermint oil and must be removed by rectification in order to improve the odor of the oil. Schimmel & Co.¹ identified dimethyl sulfide in Algerian and Réunion geranium oil: b. 37.3° – 37.5° , f.p. -83.2° , d_{20} 0.8449. $2[(\text{CH}_3)_2\text{S}] \cdot 3\text{HgCl}_2$ (cf. Faragher, Morrell and Comay²) m. 150° – 151° . $[(\text{CH}_3)_2\text{S}] \cdot \text{HgI}_2$, m. 75° .

Dimethyl sulfone m. 109° (Beilstein, Vol. I, p. 288).

Divinyl sulfide, $(\text{CH}_2=\text{CH})_2\text{S}$, and its higher homologues form the main constituent of oil of *Allium ursinum*. The physical properties observed on this natural product by Semmler,³ i.e., b. 101° , d 0.9125 are in poor agreement with the synthetic prepared later by Bales and Nickelson⁴ who reported b. 85° – 86° , d_4^{15} 0.9174. Semmler found that the HgCl_2 addition compound melted at 91° ; the platinum chloride complex at 93° .

Diallyl disulfide, $\text{CH}_2=\text{CH}\cdot\text{CH}_2\cdot\text{S}\cdot\text{S}\cdot\text{CH}_2\cdot\text{CH}=\text{CH}_2$, b. $198^\circ\text{--}200^\circ$, b_{16} $79^\circ\text{--}81^\circ$, $d_{14.8}$ 1.0237,

and

Allylpropyl disulfide, $\text{CH}_2=\text{CH}\cdot\text{CH}_2\cdot\text{S}\cdot\text{S}\cdot\text{CH}_2\cdot\text{CH}_2\cdot\text{CH}_3$, b_{16} $66^\circ\text{--}69^\circ$,

and

A compound, probably diallyl trisulfide, $\text{C}_3\text{H}_5\cdot\text{S}\cdot\text{S}\cdot\text{S}\cdot\text{C}_3\text{H}_5$, b_{16} $112^\circ\text{--}122^\circ$, d_{15} 1.0845, occurs in oil of onion, garlic, asafoetida, etc. Zinc dust reduces these products to the corresponding thioethers and oxidation prepares the sulfones all of which are liquids. (Beilstein, Vol. I, p. 441.)

Dicrotyl sulfide, $(\text{CH}_3\cdot\text{CH}=\text{CH}\cdot\text{CH}_2)_2\text{S}$, b_{17} 81° , was identified by Stevens⁵ in the scent of the common skunk (*Mephitis mephitis*).

¹ *Ber. Schimmel & Co.*, April (1909), 50.

² *J. Am. Chem. Soc.* **51** (1929), 2774.

³ *Liebigs Ann.* **241** (1887), 101.

⁴ *J. Chem. Soc.* **121** (1922), 2137.

⁵ *J. Am. Chem. Soc.* **67** (1945), 407.

3-Methylthiol Propyl Alcohol

γ -Hydroxypropyl methyl sulfide

γ -Methyl-mercapto propyl alcohol

$\text{C}_4\text{H}_{10}\text{OS}$

Mol. Weight 106.19

$\text{CH}_3\cdot\text{S}\cdot\text{CH}_2\cdot\text{CH}_2\cdot\text{CH}_2\text{OH}$

Occurrence.—Akabori and Kaneko¹ isolated this sulfur-containing alcohol from shoyu (soya) sauce.

Isolation.—By distillation of soya sauce at reduced pressure, followed by ether extraction of the distillate and refractionation, b_{15} $63^\circ\text{--}87^\circ$.

Identification.—Through the mercuric chloride addition compound $\text{C}_4\text{H}_{10}\text{OS}\cdot 2\frac{1}{2}\text{HgCl}_2$ which crystallizes in prisms m. $128^\circ\text{--}128.5^\circ$.

Properties.—According to Kirner,² and Bennett and Hock,³ synthetic γ -methyl-mercapto propyl alcohol has these properties:

b_{30}	$105^\circ\text{--}105.5^\circ$ ²	d_4^{20} (vac.)	1.030 ³
b_{24}	102° ³	d_{20}^{20}	1.0314 ²
b_{17}	$93^\circ\text{--}94^\circ$ ²	n_D^{30}	1.4832 ²

Use.—The aroma of γ -methyl-mercapto propyl alcohol is not agreeable but when added to soya sauce (0.0005–0.002 per cent) it increases the characteristic flavor of this sauce.

¹ *Proc. Imp. Acad. Tokyo* **12** (1936), 131, Osaka Univ. (original in German). *Chem. Abstracts* **31** (1937), 1355. *Chem. Zentr.* II (1936), 2391.

² *J. Am. Chem. Soc.* **50** (1928), 2452.

³ *J. Chem. Soc.* (1927), 2498.

Methyl β -Methylthiolpropionate $C_5H_{10}O_2S$

Mol. Weight 134.20

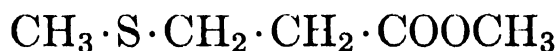

Occurrence.—This sulfur-containing ester was found by Haagen-Smit, Kirchner, Deasy and Prater¹ as a volatile constituent in the higher boiling fractions of the smooth Cayenne variety of Pineapple, *Ananas sativus* Lindl. The sulfide is present in the winter and summer fruit pulp in approximately equal quantities of 1 gram per thousand kilograms.

Isolation.—Since it was impossible to purify the compound completely by distillation, a solid derivative was prepared by oxidation of the purest fraction b_{11} 67°–71° with an excess of a 50–50 mixture of 30% hydrogen peroxide and glacial acetic acid, and ammonium molybdate as catalyst.

Identification.—Oxidation thus yielded the corresponding sulfone $C_5H_{10}SO_4$, white needles m. 94°–94.6°.

Properties.— b_{11} 69°.

Use.—Nothing is known from the literature whether this sulfide is used in the flavor industry.

¹ *J. Am. Chem. Soc.* **67** (1945), 1651.

Secondary Butyl-propenyl Disulfide

 $C_7H_{14}S_2$

Mol. Weight 162.31

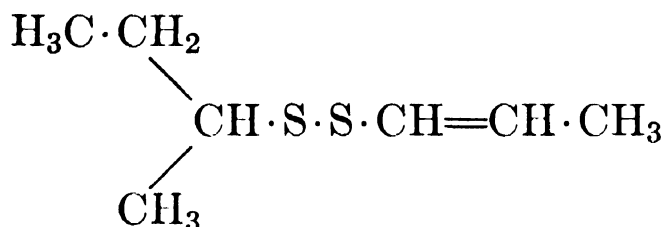

Years ago, Semmler¹ identified in the volatile oil distilled from asafoetida as main constituent (about 45 per cent) a disulfide $C_7H_{14}S_2$ which had these properties:

b_9	83°–84°
d_{15}	0.9721
α_D	–12° 30'

More recently Mannich and Fresenius² showed that this disulfide has the structural formula pictured above. From it they obtained the *l*-butyl mercaptan b. 83°–84°, $[\alpha]_D^{20}$ –11° 59', by several reductive methods. Dinitrochlorobenzene yielded with the mercaptides formed by fission: dinitrophenylpropenylthioether, $C_9H_8O_4N_2S$, m. 119°–120°, and secondary butyl dinitrophenylthioether, $C_{10}H_{12}O_4N_2S$, m. 65°–66°, $[\alpha]_D^{20}$ +1° 24'.

¹ *Arch. Pharm.* **229** (1891), 1. *Ber.* **23** (1890), 3530; **24** (1891), 78.

² *Arch. Pharm.* **274** (1936), 461. *Chem. Abstracts* **31** (1937), 1952.

Allylsulfinyl-allyl Sulfide

Allicin *

 $C_8H_{10}OS_2$

Mol. Weight 162.27

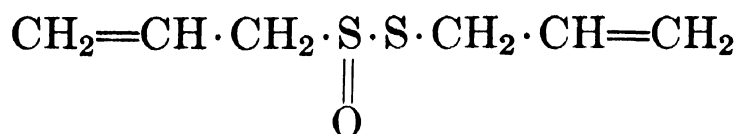

Occurrence.—This sulfur compound has been identified by Cavallito and collaborators¹ as the antibacterial principle of garlic (*Allium sativum*) where it occurs in bound form and is freed by enzymatic action.

Isolation.—Extraction of fresh garlic with 95% ethyl alcohol, steam distillation of the residue, and ether extraction of the distillate yields from 0.3 to 0.5% of allylsulfinyl-allyl sulfide.

Properties.—

d_{20}	1.112
n_D^{20}	1.561

No selective absorption between $\lambda 224-440$. The odor of this sulfur compound is much more characteristic of garlic than is the odor of the allyl sulfides. The substance decomposes on distillation at ordinary pressure. On hydrolysis, allyl disulfide and sulfur dioxide are formed. Bromine, potassium permanganate, and sodium bisulfite also cause rapid inactivation.

Its reaction with cysteine suggests the mechanism

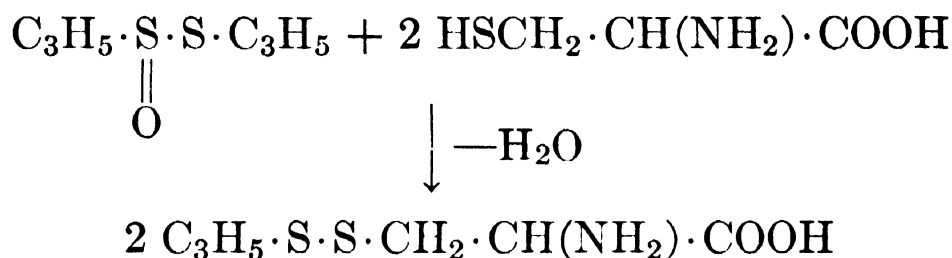

by which the compound acts as an antibacterial agent. It may operate by destroying —SH groups essential to bacterial proliferation.

Use.—As a bacteriostatic and bactericidal agent in the pharmaceutical industries. The action of allicin is considerably more bacteriostatic than bactericidal. It is about equally effective against Gram positive and Gram negative organisms. By the cylinder-plate method against *Staphylococcus aureus*, allicin shows an activity equivalent to about 15 Oxford penicillin units per mg., which is approximately 1 per cent of the activity of penicillin; however, allicin is equally effective against the Gram negative organisms which are practically unaffected by penicillin. The antibacterial activity is unaffected by the presence of *p*-aminobenzoic acid.

¹ *J. Am. Chem. Soc.* **66** (1944), 1950, 1952; **67** (1945), 1032.

* The name *allicin* has now been dropped in view of its possible confusion with certain well established medicinal products.

D. MUSTARD OILS

Introduction.—The esters of isothiocyanic acid, generally classified as mustard oils, are characterized by their pungent odor, irritating to the mucous membranes. The best-known member of this group is allyl mustard oil, commonly called “mustard oil.”

Allyl Isothiocyanate

C₄H₅NS

Mol. Weight 99.15

Isothiocyanallyl. Allyl mustard oil. “Mustard oil”



A study of the Raman spectra led Dadiou and Kohlrausch¹ to the conclusion that allyl mustard oil has this constitution:

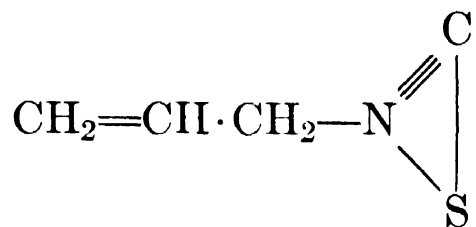

Occurrence.—Allylisothiocyanate is the principal constituent of the volatile oil of mustard (*Brassica nigra* L. or *B. juncea* L.). It has also been found in *Alliaria officinalis*, species of *Cardamine* and *Sisymbrium*, and in several other plants. According to Gildemeister and Hoffmann,² allylisothiocyanate does not occur in these plants as such but in the form of a glucoside, viz., sinigrin (myronate of potassium) which in presence of water and a ferment, viz., myrosinase, is hydrolyzed to allylisothiocyanate, *d*-glucose, and potassium bisulfate.

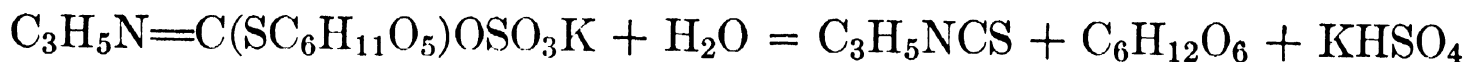

The formation of allylcyanide and carbon disulfide which are usually also present in the natural volatile mustard oil, must be explained by side reactions taking place during the hydrolysis of the glucoside sinigrin. At temperatures above 70°, the ferment myrosinase is destroyed and its action stopped. Schmidt³ found that at 0° traces of the isomeric allylthiocyanate C₃H₅·S·CN are formed, aside from allylisothiocyanate.

Isolation.—The mustard seeds are ground and freed as much as possible from fatty oils through pressure. The material is mixed with water and left for some time to ferment. After the fermentation reaction has been completed, the oil is distilled with steam. For further purification fractional distillation can be carried out.

Identification.—Allylthiocyanate (allyl mustard oil) can be characterized by several methods:

(1) By the preparation of allylthiourea (thiosinamine)

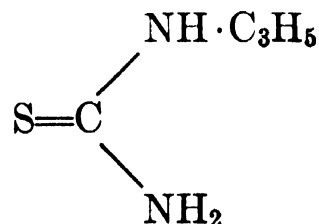

This compound is formed on treating allylthiocyanate with an excess of aqueous ammonia in the presence of some alcohol; after gentle warming (40°) the reaction accelerates and spontaneously nearly reaches the boiling point; m. 78.4° according to Tornöe.⁴

(2) By the preparation of the bornyl ester of allylthiocarbamic acid (from borneol sodium and allylthiocyanate, and by decomposition of the sodium compound with dilute acid). Roshdestvensky⁵ reported that this ester melts at 59°–60°.

(3) By the preparation of the 1-phenyl-4-allylthiosemicarbazide m. 118°, according to Blanksma.⁶

(4) On shaking allylthiocyanate with an aqueous solution of semicarbazide hydrochloride and soda, Rosenthaler⁷ prepared allyl mustard oil semicarbazide C₅H₁₀ON₄S, m. 195°–196°.

Quantitative Determination.—Regarding the quantitative determination of mustard oils, see Vol. I, Chapter 4, “The Examination and Analysis of Essential Oils, Synthetics, and Isolates,” p. 303.

Properties.—Allylthiocyanate (allyl mustard oil) is a colorless liquid of extremely pungent odor. It irritates the mucous membranes and excites the lachrymatory glands, causing the flow of tears. Applied to the skin, allyl mustard oil produces a burning sensation and causes blisters. The vapors are very harmful to the respiratory organs.

According to Kopp,⁸ the natural allyl mustard oil has these properties:

b _{728.9}	150.7°
d _{10.1} ^{10.1}	1.0173
α _D	±0°

Gildemeister and Hoffmann⁹ reported for the synthetic product:

b.	151°–153°	d ₁₅ ¹⁵	1.020–1.025
b ₅	30.2°	n _D ²⁰	1.527–1.531

These figures find ample confirmation later in the accurate determinations by Timmermans and Hennaut-Roland of the International Bureau of

Physico-Chemical Standards,¹⁰ and in data of the International Critical Tables.¹¹

f.p.	−102.5° ¹⁰
b.	152.05° ¹⁰
d ₄ ^t	{ 30° 1.00811 ¹⁰
	{ 15° 1.02356 ¹⁰
	{ 0° 1.03909 ¹⁰
n _D ²⁵	1.52481 ¹¹

Allyl mustard oil is very sparingly soluble in water, soluble in 8 volumes of 70 per cent alcohol, miscible in all proportions with ether, petroleum ether, chloroform, or benzene.

On aging, allyl mustard oil gradually turns yellow to reddish-brown. The walls of the bottle will be coated with a yellow to orange colored compound containing carbon, nitrogen, hydrogen, and sulfur. On prolonged contact with water or heavy metals (copper, silver, tin, mercury), allylisothiocyanate gradually decomposes, forming allyl cyanide b. 119°. The heavy metals react with the separating sulfur, forming sulfides. Ethyl alcohol, too, gradually reacts with allylisothiocyanate, forming thereby (partially sulfuretted) allylthiourethane

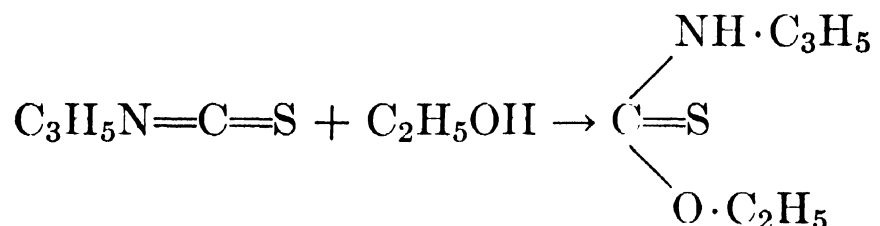

Büchi¹² found that a 2 per cent alcoholic solution of synthetic mustard oil, after eight months of storing, contained only 0.2 per cent unchanged mustard oil.

On exposure to air and especially to light, allylisothiocyanate gradually decomposes; it should therefore be stored in dark, well-filled bottles. A 15 per cent decomposition in the course of a month, with the development of several toxic products, is reported by Ganassini.¹³

Use.—Allyl mustard oil (allylisothiocyanate) is widely used for the flavoring of all kinds of food products, especially mustards and table sauces. It also finds application in many pharmaceutical preparations—plasters, for example.

Great care should be exercised in smelling allylisothiocyanate. It should be tested only when highly diluted.

¹ *Ber.* **63** (1930), 268. See also *Monatsh.* **55** (1930), 75.

² "Die Ätherischen Öle," 3d Ed., Vol. I, 686. Cf. also Obst, *Deut. Essigind.* **34** (1930), 289.

³ *Ber.* **10** (1877), 187.

⁴ *Ber.* **21** (1888), 1288.

⁵ *J. Russ. Phys. Chem. Soc.* **41** (1909), 1451.

- ⁶ *Pharm. Weekblad* **51** (1914), 1383. Cf. Dixon, *J. Chem. Soc.* **57** (1890), 263.
⁷ *Arch. Pharm.* **265** (1927), 113.
⁸ *Liebigs Ann.* **98** (1856), 375.
⁹ "Die Ätherischen Öle," 3d Ed., Vol. I, 687.
¹⁰ *J. chim. phys.* **29** (1932), 564.
¹¹ Vol. VII, 83.
¹² *Pharm. Acta Helv.* **10** (1935), 90. Cf. Sido, *Pharm. Ztg.* **80** (1935), 619.
¹³ *Arch. ist. biochim. ital.* **3** (1931), 1. *Chem. Abstracts* **26** (1932), 2657.

SUGGESTED ADDITIONAL LITERATURE

G. Malcolm Dyson, "Odor and Constitution among the Mustard Oils. VI. The Natural Mustard Oils," *Perfumery Essential Oil Record* **20** (1929), 42.

R. Meesemaecker and J. Boivin, "New Process of the Determination of Allyl Mustard Oil in Powdered Black Mustard," *J. pharm. chim.* [8], **11** (1930), 478. *Chem. Abstracts* **25** (1931), 771.

Wilhelm Schneider, Hellmuth Fischer and Walter Specht, "Sulfur Sugars and Their Derivatives. Nature of the Sugar of Mustard Oil Glucosides," *Ber.* **63B** (1930), 2787.

Hans Kaiser and Otto Leeb, "Estimation of Mustard Oil in Semen Sinapis via the D. A.-B. 6," *Süddeut. Apoth. Ztg.* **73** (1933), 612. *Chem. Abstracts* **28** (1934), 256.

R. Gros and G. Pichon, "Determination of Allyl Mustard Oil in Mustard Flour," *J. pharm. chim.* **19** (1934), 249. *Chem. Abstracts* **28** (1934), 5179.

H. Kaiser and E. Fürst, "Simple Volumetric Estimation of Mustard Oil in Spiritus Sinapis," *Apoth. Ztg.* **50** (1935), 1734. *Chem. Abstracts* **30** (1936), 1177.

Joti S. Aggarwal, "Effect of Storage on Indian Vegetable Oils," *J. Indian Chem. Soc., Ind. and News Ed.* **5** (1942), 121. *Chem. Abstracts* **37** (1943), 1885.

Propenyl Isothiocyanate



Mol. Weight 99.15



According to Pomeranz,¹ small quantities of this compound occur in mustard oil.

¹ *Liebigs Ann.* **351** (1907), 360.

 α -Secondary Butyl Isothiocyanate

Secondary Butyl Mustard Oil



Mol. Weight 115.20

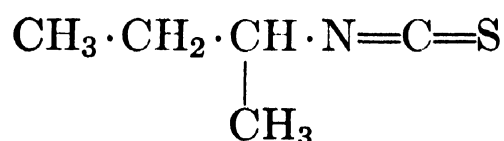

Occurrence.—This compound is the principal constituent of oil of spoonwort (*Cochleria officinalis*); it has also been found in the oils distilled from the herbs *Cochleria danica*, *Cardamine amara*, and *C. pratensis*. According to Ter

Meulen,¹ secondary butyl mustard oil occurs in these plants not as such but in the form of a glucoside, viz., glucochlearin.

Isolation.—Freed from its glucoside by enzymatic fermentation, then from the medium by steam distillation, and finally purified by fractional distillation.

Identification.—(1) According to Blanksma,² α -secondary butyl mustard oil and phenylhydrazine form β -phenyl- α -sec.-butylthiosemicarbazide m. 135°.

(2) When heated with ammonia to 100°, secondary butyl mustard oil yields an optically active thiourea m. 133°, according to Hofmann.³

Mumm and Richter⁴ prepared a mono secondary butyl thiourea m. 131°–133°, from a synthetic secondary butyl mustard oil.

(3) The secondary butyl phthalimide obtained by Mumm and Richter⁵ by heating this mustard oil with phthalic anhydride at 155°, melted at 24.5°–25.5°.

Properties.—Secondary butyl mustard oil is a colorless, optically active liquid possessing the typical odor of spoonwort oil. Hofmann⁶ reported these properties:

b.	159.5°
d ₁₂	0.944

In alcoholic solution this secondary butyl mustard oil gradually loses its original pungency, due probably to the formation of a (partially sulfuretted) thiourethane.

Use.—The natural secondary butyl mustard oil, which is not used in our industries, must not be confused with synthetic isobutyl mustard oil $(\text{CH}_3)_2 \cdot \text{CH} \cdot \text{CH}_2 \cdot \text{N}=\text{C}=\text{S}$, known commercially also as “oil of spoonwort” which boils at 162° and yields a thiourea m. 93.5°.

¹ *Rec. trav. chim.* **24** (1905), 444.

² *Pharm. Weekblad* **51** (1914), 1383. *Chem. Zentr.* I (1915), 261.

³ *Ber.* **7** (1884), 513.

⁴ *Ber.* **73B** (1940), 846, 857.

⁵ *Ibid.*

⁶ *Ber.* **7** (1884), 513.

γ -Butenyl Isothiocyanate

$\text{C}_5\text{H}_7\text{NS}$

Mol. Weight 113.18

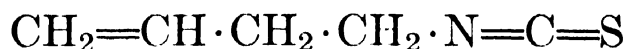

“Crotonyl” Mustard Oil

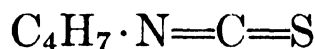

Occurrence.—Crotonyl mustard oils occur as glucosides in rapeseed (*Brassica napus*) and in Chinese colza seed (*Brassica campestris chinoleifera* sp. Viehoveer).¹ Ter Meulen² named this glucoside fluconapin. Crotonyl mustard oil has also been found in *Brassica juncea* Hook. et Thoms (from India)

by the Schimmel chemists.³ All these isolates appear to be of the formula $C_4H_7N=C=S$ but meager data suggest isomeric forms among them.

Isolation.—Crotonyl mustard oil can be obtained by steam distillation or better by distillation under reduced pressure after the above-named seeds have been mashed with crushed white mustard seed which is particularly rich in the ferment myrosinase.

Identification.—On treatment with alcoholic ammonia, the crotonyl mustard oil from *Brassica juncea* Hook., according to Schimmel & Co.,⁴ yields a thiourea crystallizing in fine needles m. $69^\circ-70^\circ$, whereas the crotonyl mustard oil from *Brassica napus* forms a thiourea m. 64° .

Properties.—The crotonyl mustard oils corresponding to the derivatives cited previously are colorless liquids, strongly refractive, possessing an odor which resembles horse-radish and allyl mustard oil. Gildemeister and Hoffmann⁵ (for that from *Brassica napus*), and Schimmel & Co.⁶ (for that from *Brassica juncea* Hook.) reported these properties:

b.	$175^\circ-176^\circ$ ⁶	α_D	$\pm 0^\circ$ ⁵
b.	174° ⁵ (with slight decomposition)	n_D^{20}	1.5240 ⁶
d_{15}^{15}	0.9941 ⁶		
d_4^{11}	0.9933 ⁵		

Apparently the crotonyl mustard oils occurring naturally are not identical with but isomeric with the synthetic crotonyl mustard oils prepared by Hoffmann,⁷ Charon,⁸ and by von Braun and Schirmacher,⁹ which products boil at $158^\circ-159^\circ$ and, according to Charon, yield a thiourea m. 105° . This mustard oil is known to be $CH_3 \cdot CH=CH \cdot CH_2-N=C=S$. It seems possible that the natural isolates are geometric isomers rather than metamers of the synthetic compound.

Use.—Natural crotonyl mustard oil has not found any worth-while use in our industries because of its toxic properties.

¹ *J. Am. Pharm. Asscn.* **10** (1921), 16.

² *Rec. trav. chim.* **24** (1905), 444.

³ *Ber. Schimmel & Co.* Oct. (1910), 114.

⁴ *Ibid.*

⁵ "Die Ätherischen Öle," 3d Ed., Vol. I, 689; Vol. II, 762, 767.

⁶ *Ber. Schimmel & Co.* (1910), 112.

⁷ *Ber.* **7** (1874), 514.

⁸ *Ann. chim. phys.* [7], **17** (1899), 262.

⁹ *Ber.* **56** (1923), 546.

Benzyl Isothiocyanate

Benzyl Mustard Oil

C₈H₇NS

Mol. Weight 149.21

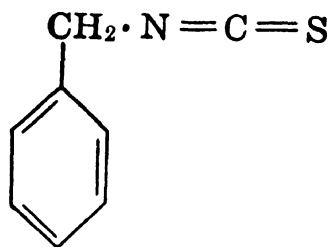

Occurrence.—Benzyl mustard oil originates through hydrolysis, caused by action of ferments on the glucoside glucotropaeolin $\text{C}_7\text{H}_7\text{N}=\text{C}(\text{SC}_6\text{H}_{11}\text{O}_5) \cdot \text{OSO}_3\text{K} + x\text{H}_2\text{O}$, which, according to Gadamer,¹ occurs in nasturtium (*Tropaeolum majus*) and probably also in the common cress (*Lepidium sativum*).

Isolation.—Freed from the natural medium by enzymatic hydrolysis and subsequent steam distillation; final purification by fractional distillation.

Identification.—Benzyl mustard oil yields:

(1) With ammonia a thiourea m. 164° (Salkovsky²)

(2) With phenylhydrazine a phenylbenzylthiosemicarbazide m. 158° (Blanksma³).

Properties.—Benzyl mustard oil is a liquid possessing a pungent odor of cress.

For the natural product from *Tropaeolum* seeds Schneider, Clibbens, Hüllweck and Steibelt⁴ observed b_{11} 125°. The compound has been described by Hofmann,⁵ Behrend and Hennicke⁶ and Hawthorne⁷ as follows:

b.	243° ⁵	d_4^{15}	1.1246 ⁷
b_{17}	140°–141° ⁶	n_D^{15}	1.6049 ⁷
b_{12}	124°–125° ⁴		

Use.—Natural benzyl mustard oil has not found any commercial use in our industries.

¹ *Arch. Pharm.* **237** (1899), 510. *Ber.* **32** (1899), 2338.

² *Ber.* **24** (1891), 2726.

³ *Pharm. Weekblad* **51** (1914), 1383. *Chem. Zentr.* I (1915), 262.

⁴ *Ber.* **47** (1914), 1256.

⁵ *Ber.* **1** (1868), 201.

⁶ *Liebigs Ann.* **344** (1906), 24.

⁷ *J. Chem. Soc.* **89** (1906), 564.

β -Phenethyl Isothiocyanate C_9H_9NS

Mol. Weight 163.24

Phenylethyl mustard oil

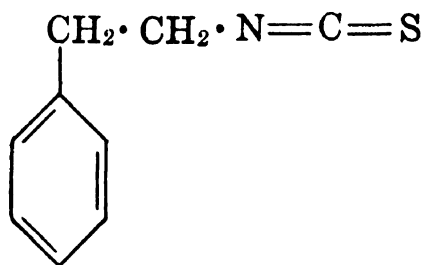

Occurrence.—Phenylethyl mustard oil is the main constituent of the oil contained in the root of *Reseda odorata*. It also occurs in the volatile oil of *Nasturtium officinale*, *Barbarea praecox*, *Brassica rapa* var. *rapifera*, and *Cochlearia armoracia* L.

Isolation.—By steam distillation. Prolonged heating converts the isocyanate into the corresponding nitrile. It is, therefore, necessary to grind the material thoroughly before distilling, so as to facilitate a speedy oil recovery.

Identification.—According to Bertram and Walbaum,¹ phenylethyl mustard oil can be identified by the preparation of several derivatives:

(1) On warming with ammonia phenylethyl mustard oil forms the thiourea:

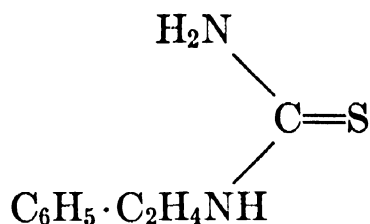

the crystals melting at 137°. Treating the thiourea with silver nitrate and baryta water, silver sulfide and phenylethyl urea m. 111°–112° are obtained.

(2) On heating phenylethyl mustard oil with concentrated hydrochloric acid in a sealed tube, the hydrochloride of phenylethyl amine is formed, the leaflets melting at 217°. Phenylethyl amine and diethyl oxalate condense to diphenylethyl oxamide m. 186°.

Properties.—Phenylethyl mustard oil is a liquid of typical horse-radish odor. Gildemeister and Hoffmann,² and Bertram and Walbaum³ reported these properties:

b.	255°–256°	d_{15}^{15}	1.0997
b_{13}	141°–142°	n_D^{20}	1.59023

Regarding the synthesis of phenylethyl mustard oil and higher homologues, see von Braun and Deutsch.⁴

Use.—Natural phenylethyl mustard oil has not found any use in our industries.

¹ *J. prakt. Chem.* [2], **50** (1894), 555.

² "Die Ätherischen Öle," 3d Ed., Vol. I, 690.

³ *J. prakt. Chem.* [2], **50** (1894), 555.

⁴ *Ber.* **45** (1912), 2188.

4-Hydroxybenzyl Isothiocyanate

C₈H₇ONS

Mol. Weight 165.21

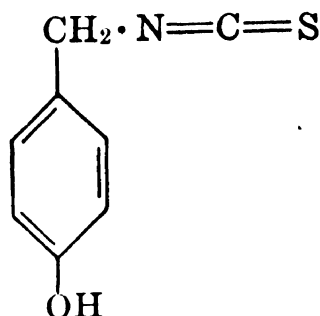
p-Hydroxybenzyl mustard oil. Sinalbin mustard oil

Occurrence and Isolation.—The glycoside sinalbin C₃₀H₄₂O₁₅N₂S₂, occurring in white mustard seed, by the action of the ferment myrosinase yields *p*-hydroxybenzyl mustard oil, glucose, and sinapine bisulfate. Sinalbin mustard oil is very sparingly volatile with steam, but yields to solvent extraction particularly by alcohol. Details about the techniques useful in obtaining sinalbin and its hydrolysis product are available in articles by Bauer and Holle,¹ and Viehoveer, Arno and Nelson.²

Identification.—Salkovsky³ identified this natural mustard oil through the isolation of the related *p*-hydroxybenzyl cyanide m. 69°–70° obtained as a decomposition product of the isothiocyanate.

Phenyl *p*-hydroxybenzyl thiourea m. 170°–171° is formed by the action of aniline on the ether solution of mustard oil and crystallizes from dilute alcohol in light yellow needles. Soluble in sodium hydroxide solution, precipitated unchanged by acids. Shaking of the alcoholic solution with water gives phenyl *p*-hydroxybenzylurea m. 140°–142°, needles from alcohol.

With phenylhydrazine in alcoholic solution, sinalbin mustard oil yields phenyl *p*-hydroxybenzyl thiosemicarbazide. Colorless leaflets from aqueous alcohol m. 124°; soluble in sodium hydroxide solution (Klein⁴).

Properties.—This substance is reported as a yellow oil, slightly soluble in water but easily so in alcohol, ether and dilute alkali. It has a burning taste and causes blisters on the skin.

Use.—*p*-Hydroxybenzyl mustard oil, as such, is not used in our industries.

¹ *Pharm. Zentralhalle* **78** (1937), 545.

² *J. Assocn. Official Agr. Chem.* **21** (1938), 488.

³ *Ber.* **22** (1889), 2137.

⁴ "Handbuch der Pflanzenanalyse," Vol. III, 1081.

TERPENES, SESQUITERPENES, AND DERIVATIVES OF UNKNOWN CONSTITUTION

Introduction.—In the course of the numerous investigations on the composition of essential oils carried out during the last hundred years, many terpenes, sesquiterpenes, and derivatives have been observed, the constitution of which, however, could not be elucidated. Thus, the literature contains countless references to fractions which have been declared terpenes, sesquiterpenes, alcohols, esters, aldehydes, ketones, etc., but in most cases the evidence is supported merely by physicochemical properties. It would serve no practical or theoretical purpose to cite all these references and to enumerate or tabulate all fractions or compounds which have been insufficiently described by the various workers. In many cases the investigators had unquestionably not even succeeded in isolating the substances in pure form and often they had in their hands mixtures of hydrocarbons or isomers. We must, therefore, restrict our description to those compounds which seem sufficiently well defined to warrant discussing, and omit the more obscure ones. However, the line cannot be drawn sharply at present, and future work will doubtless bring more clarity into this complicated and confused field.

I. HYDROCARBONS

A. TERPENES

Chamene

$C_{10}H_{16}$

Mol. Weight 136.23

According to Kafuku, Nozoe and Hata,¹ the volatile oil derived from the fresh leaves of the Formosa hinoki tree (*Chamaecyparis obtusa* Sieb. et Zucc., var. *Formosana* Hayata or Arisan-Hinoki, fam. *Pinaceae*) contains 20 to 30 per cent of a new terpene, viz., chamene, which has these properties:

b.	168°–170°	α_D	+35° 0'
b ₅₀	86°–88°	n _D ²⁵	1.4686
d ₄ ²⁵	0.8228		

Shaking chamene with sulfuric acid (1:3) at room temperature gave isochamene:

b ₅₀	88°–90°	α_D^{25}	–0° 16'
d ₄ ²⁵	0.8222	n _D ²⁵	1.4726

Unlike chamene, isochamene is fairly stable to atmospheric oxidation.

The hinoki leaf oil investigated by Uchida² was derived from a species growing in Japan and had a chemical composition somewhat different from the Formosa hinoki leaf oil described above.

¹ *Bull. Chem. Soc. Japan* **6** (1931), 47.

² *J. Soc. Chem. Ind. Japan*, **31** Suppl. Vol. (1928), 159B. *Ber. Schimmel & Co.* (1929), 49.

Dacrydene

$C_{10}H_{16}$

Mol. Weight 136.23

According to Baker and Smith,¹ oil of *Dacrydium franklini* consists mainly of a so far unknown terpene which they named dacrydene. It has these properties:

b.	165°–166° (corr.)	α_D	+12° 18'
d ₂₂	0.8524	n _D ²²	1.4749

Dacrydene forms a nitrosochloride m. 120°–121°.

¹ "Research on the Pines of Australia," Sydney (1910), 397.

Evodene

 $C_{10}H_{16}$

Mol. Weight 136.23

This terpene was observed by Asahina and Kashiwaki¹ in the volatile oil derived from the fruit of *Evodia rutaecarpa* and named evodene. The hydrocarbon, which seems to be related to myrcene, had the following properties:

b_{20}	67°–68°
d_4^{20}	0.7989
n_D^{19}	1.4843

According to Gildemeister and Hoffmann,² the designation evodene for this terpene is inappropriate because in 1911 Semmler and Schossberger³ assigned the name evodene to a new sesquiterpene isolated from the oil of *Xanthoxylum aubertia* Cordemoy. This monocyclic sesquiterpene had the following properties:

b_9	119°–123°	α_D	–58° 0'
d_{20}	0.8781	n_D	1.4990

¹ *J. Pharm. Soc. Japan* (1915), 1293. *Chem. Abstracts* **10** (1916), 607.

² "Die Ätherischen Öle," 3d Ed., Vol. I, 366.

³ *Ber.* **44** (1911), 2885.

Junene

 $C_{10}H_{16}$

Mol. Weight 136.23

Casparis and Freund¹ observed in the volatile oil derived from Tyrolean and Italian juniper berries a new terpene $C_{10}H_{16}$, viz., junene which is probably a cyclopentene derivative and similar to, but not identical with the chamene of Kafuku and collaborators (see "Chamene").

Junene, which is a strong diuretic, has these properties:

b.	164°–166°	α_D^{20}	+19° 36' to +20° 6'
b_8	53°–55°	n_D^{20}	1.4701
d_4^{20}	0.8242		

Junene yields no crystalline products with bromine, nitrosyl chloride or hydrogen iodide, but on treatment with hydrogen chloride in glacial acetic acid, junene gives an addition product b_8 76°–86°, α_D^{20} –0° 18'.

Reduction of junene yields dihydrojunene $C_{10}H_{18}$, b. 170°, b_8 58°–61°.

¹ *Pharm. Acta Helv.* **14** (1939), 1. *Chem. Abstracts* **34** (1940), 849. *Ber. Schimmel & Co.* (1940), 30.

Origanene = α -Thujene $C_{10}H_{16}$

Mol. Weight 136.23

From Cyprus *origanum* oil (probably *Origanum majoranoides* Willd.) Pickles¹ isolated a hydrocarbon which he named origanene. The same hydrocarbon was investigated by Henry and Paget.² Later Birch,³ and Birch and Earl⁴ isolated large

quantities of origanene from *Eucalyptus dives* oil and proved that origanene is in reality a mixture of *d*- and *dl*- α -thujene.

¹ *J. Chem. Soc.* **93** (1908), 862.

² *Ibid.* (1931), 27.

³ *J. Proc. Roy. Soc. N. S. Wales* **71** (1938), 330.

⁴ *Ibid.* **72** (1938), 55.

Liquidene

Kafuku, Nonoe and Hata ¹ observed in the volatile oil derived from the leaves of *Liquidambar formosana* Hance a new terpene, viz., liquidene which boiled at 170°. Liquidene seems to have one double bond.

¹ *J. Chem. Soc. Japan* **55** (1934), 244. *Chem. Abstracts* **28** (1934), 3524.

d-Thumbelen

Sebe ¹ reported the isolation of a diterpene "thumbelen" from *Pinus formosana* Hayata which, on oxidation, gave a substance C₂₀H₃₈O₆, m. 131°–132°.

Later Akiyoshi ² observed in the oil distilled from Japanese or Korean pine roots a new monocyclic terpene which he also described as "*d*-thumbelen."

¹ *J. Chem. Soc. Japan* **56** (1935), 1118.

² *Repts. Imp. Ind. Research Inst., Osaka, Japan* [10], **17** (1937), 1. *Chem. Abstracts* **31** (1937), 8172.

B. SESQUITERPENES

(a) BICYCLIC.

The Costenes

C₁₅H₂₄

Mol. Weight 204.34

Semmler and Feldstein ¹ isolated from the fractions b₁₁ 100°–130° and b₁₁ 130°–150° of costus root oil (*Saussurea lappa* Clarke) two sesquiterpenes, viz., α -costene and β -costene, respectively, which had these properties:

	α -Costene	β -Costene
b.	b ₁₂ 122°–126°	b ₁₈ 144°–149°
d.	d ₂₁ 0.9014	d ₂₂ 0.8728
α_D	–12° 0'	+6°
n _D	1.49807	1.4905
Mol. refr.	Calc. 66.15	67.86
	Found 66.37	67.65

α -Costene seems to be bicyclic and to contain two double bonds, while β -costene appears to be monocyclic and to contain three double bonds. The α - form yields a liquid hydrochloride from which the parent sesquiterpene can be regenerated, whereas the β - form does not seem to give any crystalline derivative.

¹ *Ber.* **47** (1914), 2433, 2692.

Kiganene

 $C_{15}H_{24}$

Mol. Weight 204.34

Kimura and Mizoshita¹ found in the volatile oil distilled from the root of the Japanese cedar (*Cryptomeria japonica*) a sesquiterpene $C_{15}H_{24}$, viz., kiganene, which had these properties:

$b_{4.5}$	108°–114°	$[\alpha]_D$	–22° 24'
d_4^{25}	0.9150	n_D^{25}	1.5085

On treatment with hydrogen chloride, kiganene yielded cadinene dihydrochloride m. 117°–118°; whereas on dehydrogenation in the presence of palladium asbestos, kiganene gave cadalene.

¹ *Mem. Coll. Sci. Kyoto Imp. Univ. Ser. A*, **14** (1932), 273. *Chem. Zentr. I* (1933), 418.

Mitsubene

 $C_{15}H_{24}$

Mol. Weight 204.34

Hirao¹ observed in the volatile oil distilled from Mitsuba-zeri [*Cryptotaenia japonica* Hassk. (fam. *Umbelliferae*)] a new sesquiterpene $C_{15}H_{24}$ which he named mitsubene and which had these properties:

b_{15}	142°–143°	$[\alpha]_D^{21.9}$	+8° 19'
d_4^{25}	0.9175	n_D^{25}	1.50381

Mitsubene adds four atoms of bromine and is a sesquiterpene of the eudesmene type.

¹ *J. Soc. Chem. Ind. Japan* **29** (1926), 48. *Chem. Abstracts* **20** (1926), 1070.

Didymocarpene

 $C_{15}H_{24}$

Mol. Weight 204.34

This apparently bicyclic sesquiterpene was isolated by Warsi and Siddiqui¹ from a steam distilled fraction of an ethereal extract derived from the leaves of *Didymocarpus pedicellata* and had these properties:

b_3	136°–137°	$[\alpha]_D^{36}$	–3° 42' (in 1% absolute alcohol)
b_{12}	147°–148°	n_D^{29}	1.4988
d_4^{34}	0.8957		

Blue nitroso bisnitrosite $C_{30}H_{47}N_5O_5$ m. 132°–134°.

¹ *J. Indian Chem. Soc.* **16** (1939), 423.

Dysoxylonene

Penfold ¹ found in the volatile oil derived from the wood of *Dysoxylon fraseranum* Benth. (fam. *Meliaceae*) ("Australian mahogany" or "Australian rosewood") a sesquiterpene which he named dysoxylonene. It had these properties:

b ₁₀	136°–137°	α _D ²⁰	±0°
d ₁₅ ¹⁵	0.9236	n _D ²⁰	1.5063

Dihydrochloride C₁₅H₂₄Cl₂ m. 108°–109°.

Dysoxylonene belongs to the cadinene type. On distillation with sulfur, dysoxylonene yielded cadalene which was identified by the preparation of its picrate m. 114°–115°.

¹ *J. Proc. Royal Soc. N. S. Wales* **61** (1927), 345.

Micranene

C₁₅H₂₄

Mol. Weight 204.34

Kafuku, Ikeda and Hata ¹ isolated this sesquiterpene from the volatile oil of *Lantana camara* L. Micranene was also found by Ikeda, Takeda, Nakama and Yokohara ² in the volatile oil of pha-chium, a species of camphor tree indigenous to Formosa. Shortly afterward Sebe ³ proved that micranene is in reality *dl*-cadinene.

¹ *J. Chem. Soc. Japan* **56** (1935), 1184. *Chem. Abstracts* **30** (1936), 240.

² *J. Chem. Soc. Japan* **61** (1940), 583. *Chem. Abstracts* **36** (1942), 6754.

³ *J. Chem. Soc. Japan* **61** (1940), 1269. *Chem. Abstracts* **37** (1942), 4064.

(b) TRICYCLIC.

Cyperene

C₁₅H₂₄

Mol. Weight 204.34

Kimura and Ohtani ¹ found, in the volatile oil derived from the rhizomes of *Cyperus rotundus* L. ("kobuschi"), a tricyclic sesquiterpene C₁₅H₂₄, viz., cyperene (yields as high as 32 per cent have been reported), which had the following properties:

b ₇	110°–115°	[α] _D ¹³	+1° 30'
d ₁₃ ¹³	0.9372	n _D ¹³	1.50129

(See "Cyperol" and "Cyperone.")

¹ *J. Pharm. Soc. Japan* **48** (1928), 128. *Chem. Zentr.* I (1929), 250. *Chem. Abstracts* **23** (1929), 3301.

Sesquichamene

Kafuku and Nozoe ¹ observed in the volatile oil derived from hinoki leaves [*Chamaecyparis obtusa* Sieb. et Zucc., var. *Formosana* Hayata (fam. *Pinaceae*)] a new tricyclic sesquiterpene, viz., sesquichamene, which had these properties:

b ₁₂	122.5°–123.5°	[α] _D ²⁸	–89° 51'
d ₄ ²⁸	0.9277	n _D ²⁸	1.5021

Sesquichamene forms a crystalline but unstable nitrosochloride m. 78° – 79° (with decomposition).

¹ *Bull. Chem. Soc. Japan* **6** (1931), 111. *Chem. Abstracts* **25** (1931), 4542.

(c) UNKNOWN.

Araliene

$C_{15}H_{24}$

Mol. Weight 204.34

Years ago Alpers ¹ observed in the volatile oil derived from the rhizomes of *Aralia nudicaulis* L. ("wild sarsaparilla") a sesquiterpene which he named araliene. Crystalline derivatives could not be obtained. Later Schreiner ² found that this terpene is in reality only an impure caryophyllene.

¹ *Am. J. Pharm.* **71** (1899), 370.

² Cf. "The Sesquiterpenes," Madison (1904), 27, 32.

Betulene and Betulenene

$C_{15}H_{24}$ and $C_{15}H_{22}$

Mol. Weight 204.34 and 202.33

According to Treibs,¹ birch bud oil contains a sesquiterpene mixture $C_{15}H_{24}$, viz., betulene, which is closely related to α -, β -, and γ -betulenol, three sesquiterpene alcohols $C_{15}H_{24}O$.

This mixture of sesquiterpenes

b_{20}	132° – 135°	α_D	$-11^{\circ} 30'$
d_{15}	0.911	n_D	1.502

can be separated with methyl alcohol into fractions of different solubilities and optical rotations.

Treibs reported that the same oil also contains another sesquiterpene $C_{15}H_{22}$, viz. betulenene. Because of the presence of three double bonds, betulenene lends itself readily to autoxidation and polymerization. After standing for two years it formed a solid white polymer $(C_{15}H_{22})_x$.

¹ *Ber.* **71B** (1938), 620.

Caparrapen

$C_{15}H_{24}$

Mol. Weight 204.34

Tapia ¹ isolated from the essential oil of the caparrapi balsam (*Nectandra caparrapi*) a sesquiterpene alcohol, viz., caparrapiol, which on dehydration yielded a sesquiterpene of the following properties:

b.	240° – 250°	$[\alpha]_D$	$-2^{\circ} 13'$
d_{16}	0.9019	n_D	1.4953

Dihydrochloride m. 83° .

¹ *Bull. soc. chim.* [3], **19** (1898), 643.

Equinopanacene

C₁₅H₂₄

Mol. Weight 204.34

Kariyone and Morotomi ¹ observed in the volatile oil of *Echinopanax horridus* Decne et Planch. a sesquiterpene which they named equinopanacene and which had these properties:

b ₁₅	135°–138°	[α] _D ⁵	+33° 30'
d ₄ ⁵	0.9051	n _D ¹⁸	1.50130

¹ *J. Pharm. Soc. Japan*, No. 546 (1927), 671.

Galipene

C₁₅H₂₄

Mol. Weight 204.34

Beckurts and Troeger ¹ found in the volatile oil derived from the angustora bark (*Cusparia trifoliata* Engl.) an optically inactive sesquiterpene which they named galipene. It had these properties:

b.	255°–260°
d ₁₉	0.912
n _D	1.50513

On treatment with hydrogen chloride galipene formed a liquid product which readily decomposed.

¹ *Arch. Pharm.* **235** (1897), 518, 634; **236** (1898), 402, 408. See also Beckurts and Nehring, *ibid.* **229** (1891), 612.

Ishwarene

C₁₅H₂₄

Mol. Weight 204.34

Rao, Manjunath and Menon ¹ observed in the volatile oil distilled from the roots of *Aristolochia indica* L. a mobile liquid sesquiterpene C₁₅H₂₄, viz., ishwarene, which had these properties:

b ₁₀	130°–132°	[α] _D ²⁵	–42° 22'
b _{1.0}	104°–105°	n _D ²⁵	1.5035
d ₂₅ ²⁵	0.9227		

The monohydrochloride is liquid:

b _{1.0}	128°–130°	[α] _D ³⁰	–18° 42' (in alcohol)
d ₃₀ ³⁰	1.0200	n _D ³⁰	1.5107

¹ *J. Indian Chem. Soc.* **12** (1935), 496.

Lansene

C₁₅H₂₄

Mol. Weight 204.34

Steam distilling the wood of *Lansium annamalayanum* (Beed.), Jois, Manjunath and Ramiah ¹ obtained 0.7 per cent of an oil possessing an odor of sandalwood. The oil

contained 90 per cent of a sesquiterpene $C_{15}H_{24}$, viz., lansene, which had these properties:

$b_{0.5}$	$98^{\circ}-101^{\circ}$	$[\alpha]_D^{25}$	$-82^{\circ} 9'$ (in ethyl alcohol)
d_{30}^{30}	0.8919	n_D^{30}	1.4924
<i>Monohydrochloride</i>		<i>Dihydrochloride</i>	
$b_{0.4}$	$103^{\circ}-105^{\circ}$	$b_{0.6}$	$134^{\circ}-136^{\circ}$
d_{30}^{30}	0.9750	d_{30}^{30}	1.024
α_D	$\pm 0^{\circ}$	$[\alpha]_D^{30}$	$-3^{\circ} 14'$ (in ethyl alcohol)
n_D^{30}	1.4985	n_D^{30}	1.4954

Aside from lansene, the oil also contained a sesquiterpene alcohol, viz., lansol.

¹ *J. Mysore Univ. B*, **1** (1941), 171. *Chem. Abstracts* **36** (1942), 3319.

Libocedrene

$C_{15}H_{24}$

Mol. Weight 204.34

Schorger ¹ observed in the volatile oil derived from the needles of the Californian *Libocedrus decurrens* Torrey, fam. *Pinaceae* ("incense cedar") a sesquiterpene which he named libocedrene. It had these properties:

b.	$260^{\circ}-280^{\circ}$	α_D^{26}	$+6^{\circ} 24'$
d_{20}	0.9292	n_D^{20}	1.4994

Hydrochloride m. $132^{\circ}-133^{\circ}$.

¹ *J. Ind. Eng. Chem.* **8** (1916), 22.

Populene

$C_{15}H_{24}$

Mol. Weight 204.34

Nakao ¹ found in the oil derived from the leaf buds of the Manchurian black poplar (*Populus nigra* L.) a sesquiterpene which he named populene. It had these properties:

b_8	$121^{\circ}-122^{\circ}$	α_D	$+21^{\circ} 13'$
d_{15}	0.9135	n_D	1.504

Hydrochloride m. 87° .

Hydrobromide m. 117° .

Dehydrogenation with sulfur yielded a hydrocarbon, the picrate of which melted at 115° .

¹ *J. Pharm. Soc. Japan*, No. 513 (1924). *Chem. Zentr.* I (1925), 974.

Torilene

$C_{15}H_{24}$

Mol. Weight 204.34

Kariyone and Majima ¹ found in the oil distilled from the fruit of *Torilis anthriscus* Gmel. a sesquiterpene, viz., torilene. The sulfate of torilene $C_{15}H_{24} \cdot SO_4H_2$, m. 145° , on boiling with 10 per cent alcoholic potassium hydroxide, yielded torilene hydrate $C_{15}H_{26}O$, m. $51^{\circ}-55^{\circ}$.

¹ *J. Pharm. Soc. Japan* **55** (1935), 887 (in German 168). *Chem. Abstracts* **30** (1936), 572. *Ber. Schimmel & Co.* (1936), 87.

Junipene

 $C_{15}H_{24}$

Mol. Weight 204.34

Mattsson¹ observed in the volatile oil derived from the bark of *Juniperus communis* a sesquiterpene which he named junipene. It had these properties:

b_{767}	256.5°–257°	$[\alpha]_D^{20}$	+41° 3'
d_{20}^{20}	0.9401	n_D^{20}	1.50289

Hydrochloride m. 58.5°.

¹ Bidrag till kännedom af Finlands natur och folk. Utgifna af Finska Vetenskaps-Societeten. H. 72. Nr. 1. Helsingfors (1913). *Ber. Schimmel & Co.* (1924), 89.

Camerene

Kafuku, Ikeda and Fujita¹ isolated from the volatile oil of *Lantana camara* L. a sesquiterpene, viz., camerene, which had these properties:

b.	263°	α_D^{27}	+6° 44'
b_5	121°–122°	n_D^{30}	1.5000
d_4^{30}	0.9056		

Camerene is unstable and changes into isocamerene, a sesquiterpene of the following properties:

b.	253°	α_D^{27}	–11° 13'
b_5	110°–111°	n_D^{30}	1.4925
d_4^{30}	0.8942		

Camerene is of the caryophyllene type, isocamerene of the cadinene type.

b_{20}	132°	$[\alpha]_{546}$	–27° 0'
d_{25}	0.9112	$[\alpha]_{579}$	–23° 37'
		n_D^{25}	1.50167

From the essential oil of the wood of *Juniperus oxycedrus* the same authors isolated also an isomer of this sesquiterpene

m.	118°–119°		
$[\alpha]_{546}$	–103° 30'		
$[\alpha]_{579}$	–89° 12' (2.85% solution in benzene)		

¹ *J. Chem. Soc. Japan* **56** (1935), 1184. *Chem. Abstracts* **30** (1936), 240.

C. AROMATIC HYDROCARBONS

Sequoiene

 $C_{13}H_{10}$

Mol. Weight 166.21

Lunge and Steinkauler¹ found this hydrocarbon belonging to the aromatic series in the oil derived from needles of *Sequoia gigantea*. It forms leaf-like crystals with a reddish fluorescence, m. 105°, b. 290°–300°. With picric acid, sequoiene forms an addition product crystallizing in the form of red needles.

¹ *Ber.* **13** (1880), 1656; **14** (1881), 2202.

II. ALCOHOLS

A. TERPENE ALCOHOLS

Artemisol

$C_{10}H_{18}O$

Mol. Weight 154.24

Kinney, Jackson, DeMytt and Harris ¹ found in the volatile oil distilled from Utah sage brush (*Artemisia tridentata*) a liquid terpene alcohol, isomeric with terpineol, which they named artemisol. Hydrogenation showed that this sage alcohol has the *p*-menthan-9-ol structure but the actual position of the double bond in artemisol has not yet been established. Synthesis will have to be resorted to in order to prove complete details of the structure of artemisol.

¹ *J. Org. Chem.* **6** (1941), 612.

Benihinol = *d*-Myrtenol

$C_{10}H_{16}O$

Mol. Weight 152.23

According to Kafuku and Ichikawa,¹ the volatile oil derived from the wood of *Chamaecyparis formosensis* Matsum contains a monocyclic unsaturated primary terpene alcohol $C_{10}H_{16}O$, viz., benihinol. Later Sebe ² showed that benihinol is in reality none other than *d*-myrtenol.

¹ *J. Chem. Soc. Japan* **54** (1933), 1011.

² *J. Chem. Soc. Japan* **62** (1941), 22. *Chem. Abstracts* **37** (1943), 4064.

Benihinol = *d*-Dihydromyrtlenol

$C_{10}H_{18}O$

Mol. Weight 154.24

According to Kafuku and Ichikawa,¹ the volatile oil derived from the wood of *Chamaecyparis formosensis* Matsum contains a bicyclic primary terpene alcohol $C_{10}H_{18}O$, viz., benihinol. Later Sebe ² showed that benihinol is in reality a *d*-rotatory dihydromyrtlenol.

¹ *J. Chem. Soc. Japan* **54** (1933), 1011.

² *J. Chem. Soc. Japan* **59** (1938), 1285. *Chem. Abstracts* **33** (1939), 2127. See also *J. Chem. Soc. Japan* **62** (1941), 22. *Chem. Abstracts* **37** (1943), 4064.

Darwinol = *d*-Myrtenol

$C_{10}H_{16}O$

Mol. Weight 152.23

Years ago, Penfold ¹ observed in oil of *Darwinia grandiflora* a terpene alcohol which he named darwinol. The same alcohol was found in other volatile oils, viz., *Boronia dentigeroides* Cheel (fam. *Rutaceae*), *Leptospermum lanigerum*, and *Eriostemon coxi*.

More recently, Penfold, Ramage and Simonsen ² proved that darwinol is in reality *d*-myrtenol.

¹ *J. Proc. Roy. Soc. N. S. Wales* **57** (1923), 237.

² *Ibid.* **68** (1934), 36.

Uncineol

$C_{10}H_{18}O$

Mol. Weight 154.24

Baker and Smith ¹ found in the fractions boiling above 197° of cajuput oil (*Melaleuca uncinata*) an alcohol which they named uncineol. The snow white crystals melted at 72.5°. $[\alpha]_D^{20} +36^\circ 59'$ (in absolute alcohol).

¹ *J. Proc. Roy. Soc. N. S. Wales* **41** (1907), 204.

B. SESQUITERPENE ALCOHOLS

(a) MONOCYCLIC.

Fokienol

$C_{15}H_{26}O$

Mol. Weight 222.36

Glichitch ¹ isolated from the volatile oil of *Fokienia hodginsii* distilled in Tonkin an easily dehydrated tertiary monocyclic sesquiterpene alcohol $C_{15}H_{26}O$ which had a very strong tendency to isomerize and which Glichitch named fokienol. It is a fairly viscous almost colorless oil with a faint balsamic odor. Fokienol has these properties:

b_2	125°–126° (corr.)	$[\alpha]_D$	+18° 35'
d_{23}	0.9236	$n_D^{23.5}$	1.4975

Dehydrogenation with sulfur yielded mainly cadalene.

On dehydration, fokienol forms the corresponding monocyclic sesquiterpene, viz., fokienene which is instantly and almost quantitatively isomerized to isofokienene, $C_{15}H_{24}$.

¹ *Parfums France* **8** (1930), 157.

(b) BICYCLIC.

Amyrol

$C_{15}H_{26}O$

Mol. Weight 222.36

Years ago the sesquiterpene alcohols occurring in West Indian sandalwood oil were called amyrols until Ruzicka, Capato and Huyser ¹ showed that the higher boiling fractions of this oil consist of a mixture of several, mainly bicyclic sesquiterpene alcohols $C_{15}H_{26}O$, in which one or several cadinols predominate.

¹ *Rec. trav chim.* **47** (1928), 378.

Atractylol

$C_{15}H_{26}O$

Mol. Weight 222.36

Years ago Gadamer and Amenomiya ¹ observed in the oil derived from the roots of *Atractylis ovata* Thunb., a sesquiterpene alcohol $C_{15}H_{26}O$,

m.	59°
b.	290°–292°
b_{15}	162°
n_D	1.51029–1.51101

which they named atractylol. More recently Ruzicka, Koolhaas and Wind² showed that atractylol is in reality a mixture of mainly eudesmol and other sesquiterpene alcohols.

¹ *Arch. Pharm.* **241** (1903), 25.

² *Helv. Chim. Acta* **14** (1931), 1178.

Bulnesol

$C_{15}H_{26}O$

Mol. Weight 222.36

Wienhaus and Scholz¹ isolated from guaiac wood oil a simple, unsaturated, bicyclic, tertiary sesquiterpene alcohol $C_{15}H_{26}O$ which they named bulnesol. This alcohol, which is isomeric with guaiol, had these properties:

m.	69°–70°	d_4^{70}	0.9389
b_4	136°–138°	n_D^{70}	1.48915

¹ *Ber. Schimmel & Co., Jubiläums Ausgabe* (1929), 269.

Cinnamonol, Foliol and Combanol

$C_{15}H_{26}O$

Mol. Weight 222.36

Treating the sesquiterpene fraction of cinnamon leaf oil with phthalic anhydride, Glichitch¹ isolated three bicyclic sesquiterpene alcohols, $C_{15}H_{26}O$, which he named cinnamonol, foliol, and combanol.

Cinnamonol.—This primary alcohol $b_{2.5}$ 130°–135°, d_{21}^{21} 0.9753, α_D^{21} $-30^\circ 40'$, n_D^{21} 1.513 is a viscid yellow oil of agreeable, persistent odor.

Foliol.—This secondary alcohol $b_{2.5}$ 133°–135°, d_{16}^{16} 0.9729, α_D^{18} $-15^\circ 50'$, n_D^{16} 1.514 is an even more syrupy oil of similar but fainter odor.

Combanol.—This tertiary alcohol $b_{1.5}$ 115°–116°, $d_{1.5}^{21.5}$ 0.9687, α_D^{17} $\sim 0^\circ$, $n_D^{21.5}$ 1.50702 is a very thick oil of wax-like character. Dehydration by warming with concentrated formic acid yielded the corresponding sesquiterpene, viz., combanene, b_{10} 126°–127°, $d_{18.5}^{18.5}$ 0.9207, α_D^{18} $-28^\circ 20'$, n_D^{16} 1.5106, a colorless oil with a faint odor reminiscent of citronellal hydrate.

All three alcohols give oily phenylurethanes.

¹ *Parfums France* **3** (1925), 124.

Costol

$C_{15}H_{24}O$

Mol. Weight 220.34

This bicyclic primary sesquiterpene alcohol containing two double bonds was found by Semmler and Feldstein¹ in the fraction b_{11} 175°–190° (d_{21} 1.0082, α_D $+33^\circ$, n_D 1.51962) of costus root oil (*Saussurea lappa* Clarke). Being a primary alcohol, costol readily reacts with phthalic anhydride and can be regenerated from the acid phthalate.

Thus isolated and purified, costol has these properties:

b_{11}	169°–171°	n_D	1.5200
d_{21}	0.9830	Mol. refr.	Calc. 67.67
α_D	$+13^\circ 0'$		Found 67.90

On oxidation with chromic acid in glacial acetic acid solution, costol yields an aldehyde $C_{15}H_{22}O$ which can be characterized by the preparation of a semicarbazone m. 217° – 218° . This aldehyde, b_{15} 164° – 165° , d_{22} 0.9541, $\alpha_D +24^{\circ}$, n_D 1.50645, should theoretically have a density of about 0.99; therefore molecular rearrangements seem to take place in the course of the oxidation.

On treatment with phosphorous trichloride, costol yields costyl chloride $C_{15}H_{23}Cl$, b_{13} 160° – 165° which, by reduction with sodium and alcohol, gives isocostene $C_{15}H_{24}$, a sesquiterpene probably of caryophyllene type and containing two double bonds.

Isocostene has these properties:

b_{12}	130° – 135°	n_D	1.50246
d_{21}	0.9062	Mol. refr.	Calc. 66.15
α_D	$+31^{\circ} 0'$		Found 66.37

¹ *Ber.* **47** (1914), 2433, 2687.

Cryptomeradol = Eudesmol

$C_{15}H_{26}O$

Mol. Weight 222.36

Wienhaus and Scholz ¹ isolated from Japanese cedar wood oil (*Cryptomeria japonica* Don.) a new sesquiterpene alcohol $C_{15}H_{26}O$ which they named cryptomeradol. According to later investigations by Ruzicka, Koolhaas and Wind,² cryptomeradol is actually eudesmol.

¹ *Ber. Schimmel & Co., Jubiläums Ausgabe* (1929), 275.

² *Helv. Chim. Acta* **14** (1931), 1178.

Kiganol

$C_{15}H_{26}O$

Mol. Weight 222.36

Kimura and Mizoshita ¹ found in the volatile oil distilled from the root of the Japanese cedar (*Cryptomeria japonica*) a sesquiterpene alcohol $C_{15}H_{26}O$, viz., kiganol, a yellow-green liquid which, on exposure to air, turned bluish-green. Kiganol had these properties:

b_9	145° – 150°	$[\alpha]_D$	$-6^{\circ} 20'$
d_4^{25}	0.9657	n_D^{25}	1.5055

On dehydrogenation with sulfur, kiganol yielded cadalene.

In regard to the physical properties, kiganol resembled the cryptomeriol of Kimura,² and the sesquiterpene alcohol isolated by Uchida ³ from the leaf oil of *Cryptomeria japonica* Don.

The findings of Kimura and Mizoshita do not conform with those of other authors, viz., Wienhaus and Scholz,⁴ and Sugii and Sengoku ⁵ who isolated from Japanese cedar root oil cryptomeradol and machilol, respectively. Ruzicka, Koolhaas and Wind ⁶ proved that cryptomeradol as well as machilol is identical with eudesmol.

¹ *J. Chem. Soc. Japan* **51** (1930), 520. *Chem. Abstracts* **26** (1932), 719.

² *Ber. deut. pharm. Ges.* **19** (1909), 369. *Chem. Zentr.* I (1910), 275.

³ *J. Am. Chem. Soc.* **38** (1916), 687.

⁴ *Ber. Schimmel & Co., Jubiläums Ausgabe* (1929), 267, 275.

⁵ *J. Pharm. Soc. Japan* **51** (1931), 21. *Chem. Zentr.* I (1931), 3233.

⁶ *Helv. Chim. Acta* **14** (1931), 1178.

Machilol = Eudesmol $C_{15}H_{26}O$

Mol. Weight 222.36

This bicyclic tertiary sesquiterpene alcohol was found by Takagi ¹ in the oil derived from the wood of *Machilus kusanoi* Hayata (fam. *Lauraceae*). Sugii and Shindo ² isolated machilol from the oil of the bark of *Magnolia obovata* Thunb. Sugii and Sengoku ³ reported the occurrence of machilol in Japanese cedarwood oil. Almost simultaneously Ruzicka, Wind and Koolhaas ⁴ showed that the machilol of Takagi, and of Sugii and Shindo is in reality eudesmol, the β - form predominating over the α - form.

¹ *J. Pharm. Soc. Japan* (1921), 565.² *Ibid.* **50** (1930), 709.³ *Ibid.* **51** (1931), 21 (abstracts in German).⁴ *Helv. Chim. Acta* **14** (1931), 1132, 1171.**Selinenol** $C_{15}H_{26}O$

Mol. Weight 222.36

Some years ago, Ruzicka and Stoll ¹ observed in celery seed oil sesquiterpene alcohols of bicyclic nature. Later, Ruzicka, Wind and Koolhaas ² came to the conclusion that the selinenol $C_{15}H_{26}O$ obtained from selinene $C_{15}H_{24}$ consists actually of mainly α -eudesmol and some β -eudesmol.

¹ *Helv. Chim. Acta* **6** (1923), 852.² *Ibid.* **14** (1931), 1132.**Sesquigoyol** $C_{15}H_{26}O$

Mol. Weight 222.36

Sebe ¹ observed in the wood turpentine oil from *Pinus formosana* Hayata a bicyclic tertiary sesquiterpene alcohol $C_{15}H_{26}O$, viz., sesquigoyol. A few years later, the same author isolated sesquigoyol from the oil of *Pinus pentaphylla* distilled in Formosa. In the opinion of Sebe, ² sesquigoyol is γ -cadinol.

¹ *J. Chem. Soc. Japan* **56** (1935), 1118. *Chem. Abstracts* **30** (1936), 603.² *J. Chem. Soc. Japan* **61** (1940), 1269. *Chem. Abstracts* **37** (1943), 4064.**Taiwanol** $C_{15}H_{26}O$

Mol. Weight 222.36

Kafuku and Kato ¹ found in the volatile oil derived from the wood of the Formosa taiwan cedar (*Taiwania cryptomerioides* Hayata, fam. *Coniferae*) a sesquiterpene alcohol $C_{15}H_{26}O$, viz., taiwanol, which had these properties:

b_6	141°–143°	α_D^{30}	–42° 33'
d_4^{20}	0.9692	n_D^{30}	1.5045

On treatment with hydrogen chloride, taiwanol yielded cadinene dihydrochloride m. 117°–118°. In general, taiwanol resembled cadinol, but, contrary to cadinol, taiwanol gave a phenylurethane m. 134°–135°.

¹ *Bull. Chem. Soc. Japan* **6** (1931), 3. *Chem. Abstracts* **25** (1931), 3125. *Ber. Schimmel & Co.* (1932), 63.

(c) TRICYCLIC.

Cyperol

$C_{15}H_{24}O$

Mol. Weight 220.34

Kimura and Ohtani ¹ found in the volatile oil derived from the rhizomes of *Cyperus rotundus* L. ("kobuschi") a tricyclic tertiary sesquiterpene alcohol $C_{15}H_{24}O$, viz., cyperol (yields as high as 49 per cent have been reported), which had these properties:

b_8	147°–150°	$[\alpha]_D^{20}$	+29° 30'
d_{20}^{20}	1.0055	n_D^{20}	1.51066

Cyperol, as well as cyperene, seems to consist of two isomers. (See "Cyperene.")

¹ *J. Pharm. Soc. Japan* **48** (1928), 128. *Chem. Zentr.* I (1929), 250. *Chem. Abstracts* **23** (1929), 3301.

Sesquicryptol

$C_{15}H_{26}O$

Mol. Weight 222.36

Uchida and Murata ¹ isolated from the essential oil (fraction b_2 170°–180°) of Japanese sugi leaves (*Cryptomeria japonica* Don.) a new crystalline monocyclic, probably primary sesquiterpene alcohol $C_{15}H_{26}O$ which they named sesquicryptol and which, after repeated fractionation, had these properties:

$m.$	49°–51°	$[\alpha]_D^{22}$	+22° 43' (in a 10.92% chloroform solution)
b_2	172°–174°	n_D^{50}	1.4978
d_4^{50}	0.9031		

Sesquicryptol yields a liquid tetrabromide, a liquid dihydrochloride, and a liquid acetate.

On treatment with phosphorous pentoxide, sesquicryptol forms a liquid sesquiterpene $C_{15}H_{24}$,

b_{76}	250°–255°	α_D	±0°
d_4^{25}	0.9078	n_D^{25}	1.4980

which gives a dibromide. This sesquiterpene seems to be of tricyclic nature and to possess one double bond.

It should be noted in this connection that years ago Uchida ² had isolated from the leaf oil of *Cryptomeria japonica* a sesquiterpene alcohol $C_{15}H_{26}O$ of unknown constitution which possessed these properties:

$b.$	284°–286°	$[\alpha]_D^{15}$	+16° 46' (in 5% chloroform solution)
$d_{15.5}^{15.5}$	0.9623	$n_D^{22.8}$	1.5048

¹ *J. Soc. Chem. Ind. Japan* **40**, Suppl. Binding (1937), 159. *Chem. Abstracts* **31** (1937), 6646.

² *J. Am. Chem. Soc.* **38** (1916), 693.

Shojunol

 $C_{15}H_{26}O$

Mol. Weight 222.36

Ono, Kimura and Imoto ¹ observed in brown camphor oil a secondary, apparently saturated tricyclic sesquiterpene alcohol $C_{15}H_{26}O$, viz., shojunol, which had these properties:

m.	96°	$[\alpha]_D^{20}$	+25°
b.	273°–278°	n_D^{19}	1.5026
d_4^{18}	0.9643		

Phenylurethane m. 134.5°.

¹ *J. Chem. Soc. Japan* **57** (1936), 119. *Chem. Abstracts* **30** (1936), 4995.

(d) UNKNOWN.

Galipol

 $C_{15}H_{26}O$

Mol. Weight 222.36

This sesquiterpene alcohol was described by Beckurts and Troeger ¹ as the aromatic principle of the volatile oil derived from the angustora bark (*Cusparia trifoliata* Eng.). Galipol is unstable and loses water on warming. The above named authors reported these properties of galipol:

b.	260°–270°	α_D	±0°
d_{20}	0.9270	n_D^{20}	1.50624

¹ *Arch. Pharm.* **235** (1897), 527, 634; **236** (1898), 408. See also Beckurts and Nehring, *ibid.* **229** (1891), 612.

Ipomoeol and Saccharol

 $C_{15}H_{24}O$

Mol. Weight 220.34

Taira and Masujima ¹ observed in the unsaponifiable portions of fusel oils from sweet potato and molasses a tertiary sesquiterpene alcohol $C_{15}H_{24}O$ which did not react with phthalic anhydride. This alcohol, according to its origin from sweet potatoes or molasses, was called ipomoeol and saccharol, respectively.

¹ *J. Agr. Chem. Soc. Japan* **10** (1934), 232. *Chem. Abstracts* **28** (1934), 4171.

Ishwarol

 $C_{15}H_{24}O$

Mol. Weight 220.34

Rao, Manjunath and Menon ¹ observed in the volatile oil distilled from the roots of *Aristolochia indica* L. a sesquiterpene alcohol $C_{15}H_{24}O$, viz., ishwarol, which had these properties:

$b_{1.0}$	126°–128°	$[\alpha]_D^{30}$	–7° 17'
d_{30}^{30}	0.9926	n_D^{30}	1.5098

¹ *J. Indian Chem. Soc.* **12** (1935), 494. *Chem. Abstracts* **30** (1936), 234.

Juniperol

 $C_{15}H_{24}O$

Mol. Weight 220.34

Ramsey¹ prepared from juniper bark by steam distillation a solid sesquiterpene alcohol $C_{15}H_{24}O$ which, on recrystallization from alcohol, melted at 107° , d. 1.0116. Somewhat later Mattsson² reported the following properties of this so-called juniperol:

m.	106.8° – 107.2° (corr.)	$[\alpha]_D^{20}$	$+17^{\circ} 49'$ (in alcohol)
d_{20}^{20}	1.0460		to $+18^{\circ} 24'$ (in chloroform)
		n_D	1.519

Dehydration by warming with 60 per cent sulfuric acid yielded juniperene $C_{15}H_{22}$:

b.	251° – 253°	$[\alpha]_D^{20}$	$-29^{\circ} 52'$
d_{20}^{20}	0.9331	n_D^{20}	1.50233

Some years later, Hintikka³ challenged the findings of Mattsson as far as the proposed constitution of juniperene is concerned.

¹ *Z. Kristallogr.* **46** (1909), 281.

² Bidrag till kännedom af Finlands natur och folk. Utgifna af Finska Vetenskaps-Societeten, H. 72, Nr. 1, Helsingfors (1913). *Ber. Schimmel & Co.* (1924), 89.

³ *Ann. Acad. scient. Fennicae*, Ser. A, Vol. XX, No. 4, Helsinki (1923). *Ber. Schimmel & Co.* (1924), 90.

Kuromatsuol

Akiyoshi¹ observed in the oil distilled from Japanese or Korean pine roots a new sesquiterpene alcohol, viz., kuromatsuol.

¹ *Repts. Imp. Ind. Research Inst., Osaka, Japan* [10], **17** (1937), 1. *Chem. Abstracts* **31** (1937), 8172.

Maali Alcohol

 $C_{15}H_{26}O$

Mol. Weight 222.36

According to Schimmel & Co.,¹ the volatile oil derived from maali gum contains a sesquiterpene alcohol $C_{15}H_{26}O$, m. 105° , which yields a chromate m. 111° .

¹ *Ber. Schimmel & Co.*, Oct. (1908), 79. Cf. Gildemeister and Hoffmann, "Die Ätherischen Öle," 3d Ed., Vol. I, 503.

Macrocarpol

 $C_{15}H_{26}O$

Mol. Weight 222.36

According to Briggs and Sutherland,¹ the fraction b_5 130° – 150° of the volatile oil obtained by steam distillation of the leaves and terminal branchlets of *Cupressus macrocarpa* contains a sesquiterpene alcohol $C_{15}H_{26}O$, viz., macrocarpol which has these properties:

m.	108°
$[\alpha]_D^{25}$	$+25^{\circ} 24'$ (c = 5.24 in ethereal alcohol)

Naphthylurethane m. 88° – 91° .

3,5-Dinitrobenzyl ester m. 157° – 158° .

¹ *J. Org. Chem.* **7** (1942), 404

Matico Camphor

 $C_{15}H_{26}O$

Mol. Weight 222.36

According to Gildemeister and Hoffmann,¹ this substance was formerly obtained from the oil of matico leaves in the form of thick hexagonal prisms m. 94° , $[\alpha]_D -28^{\circ} 44'$ (in chloroform solution).

More recent work of Böhme² showed that matico camphor, when recrystallized from 96 per cent alcohol, melts at 94° and sublimes *in vacuo* (0.06 mm. at 70° – 80°). Its formula $C_{15}H_{26}O$ points to a tricyclic system or to a bicyclic with a double bond, a monocyclic with two double bonds, or an aliphatic with three double bonds, respectively. Matico camphor is related to the azulene-forming sesquiterpene alcohols. Whether this azulene is identical with the already known azulene is not yet proved.

¹ "Die Ätherischen Öle," 3d Ed., Vol. I, 499.

² *Arch. Pharm.* **278** (1940), 377. *Chem. Abstracts* **35** (1941), 2673.

Luparenol

 $C_{15}H_{24}O$

Mol. Weight 220.34

Chapman,¹ on treating the fraction b_4 110° – 150° of hops oil with phthalic anhydride isolated a sesquiterpene alcohol $C_{15}H_{24}O$, viz., luparenol, which contains one ethylenic linkage. Luparenol has these properties:

b_3	125° – 128°	$[\alpha]_D^{20}$	$-3^{\circ} 42'$
d_{20}^{20}	0.9738	n_D^{20}	1.5023

Phenylurethane m. 157° .

¹ *J. Chem. Soc.* (1928), 1303; **67** (1895), 54.

Partheniol

 $C_{15}H_{26}O$

Mol. Weight 222.36

According to Walter,¹ this sesquiterpene alcohol occurs as cinnamate in guayule resin (*Parthenium argentatum* Gray). The alcohol melts at 131° , $[\alpha]_D^{24} +88^{\circ} 42'$ (in chloroform $c = 1.566$), the cinnamate at 125° – 126° .

¹ *J. Am. Chem. Soc.* **66** (1944), 419.

Sagittol

 $C_{15}H_{26}O$

Mol. Weight 222.36

Yanovsky¹ and later White and Jenkins² observed in the volatile oil distilled from the roots and rhizomes of *Balsamorhiza sagittata* (Pursh) Nutt. a sesquiterpene alcohol $C_{15}H_{26}O$, viz., sagittol. It had these properties:

m.	77° – 78° (uncorr.)	
$[\alpha]_D^{20}$	$+25^{\circ} 48'$ (95% ethyl alcohol, $c = 2.080$)	
n_D	1.520 (α)	} observed on crystals
n_D	1.540 (γ)	

¹ *J. Am. Chem. Soc.* **52** (1930), 3446.

² *Pharm. Arch.* **13** (1942), 49.

Shairol

$C_{15}H_{26}O$

Mol. Weight 222.36

Kir'yalov ¹ isolated from the volatile oil of *Ferula pyramidata* (kar. et kir.) Eug. Kor. (syn. *F. paniculata* LDB) a sesquiterpene alcohol $C_{15}H_{26}O$, viz., shairol which had these properties:

m.	91°–93°	d_{20}^{20}	0.9899
b_{10}	146°–147°	$[\alpha]_D^{18}$	–25° 54'

¹ *J. Gen. Chem. U.S.S.R.* **13** (1943), 145. *Chem. Abstracts* **38** (1944), 1488.

Carotol

$C_{15}H_{26}O$

Mol. Weight 222.36

Asahina and Tsukamoto ¹ found, in the oil derived from the seeds and stems of carrots, *Daucus carota* L., a sesquiterpene alcohol, $C_{15}H_{26}O$, of mobile consistency, which they named carotol. It had these properties:

$b_{1.5}$	109°	$[\alpha]_D$	+27° 54' and +28° 2' (in alcohol)
d_4^{15}	0.9646	n_D^{15}	1.4912

The alcohol is apparently saturated and, on oxidation with potassium permanganate, yields a sesquiterpene glycol, viz., dihydroxycarotol, $C_{15}H_{28}O_3$, m. 142°, $[\alpha]_D$ –2° 25'; monobenzoate m. 83°–83.5°. When treated with bromine in glacial acetic acid, carotol yields a dibromide m. 58.5°. On boiling of this dibromide with silver benzoate and on saponification of the resulting product with alcoholic potassium hydroxide, daucol, $C_{15}H_{26}O_2$, m. 118.5°, $[\alpha]_D$ –15° 6', is obtained. The latter yields an acetyl derivative m. 81.3°.

¹ *J. Pharm. Soc. Japan*, No. 525 (1925), 961. *Ber. Schimmel & Co.* (1927), 70.

Daucol

$C_{15}H_{26}O_2$

Mol. Weight 238.36

Richter ¹ found in the high boiling fraction of carrot seed oil, *Daucus carota* L., a crystalline compound $C_{15}H_{26}O_2$ which he believed to be a dihydroxysesquiterpene alcohol, assigning to it the name daucol. When purified through its xanthogenate, the alcohol had these properties:

m.	115°–116°
$[\alpha]_D^{14}$	–17° 9' to –17° 28'

The presence of two atoms of oxygen points toward two hydroxyl groups but only one group can be acetylated. The alcohol does not add bromine.

¹ *Arch. Pharm.* **247** (1909), 391, 401. See also Deussen and Hahn, *Ber.* **43** (1910), 523. *Ber. Schimmel & Co.*, April (1910), 73.

Sesquibenihiol

 $C_{15}H_{26}O_2$

Mol. Weight 238.36

Katsura¹ isolated a sesquiterpenediol $C_{15}H_{26}O_2$, m. 120° – 130° , $b_{0.01}$ 125° – 130° $[\alpha]_D^{19}$ $-36^{\circ} 1'$, from the volatile oil occurring in the root of *Chamaecyparis formosensis* Matsum, and named it sesquibenihiol. It gives a monoester of phthalic acid; hence the conclusion may be drawn that one of the two OH groups is of primary nature, and the other of tertiary nature. Other chemical evidence indicates that sesquibenihiol is an α -glycol.

¹ *J. Chem. Soc. Japan* **63** (1942), 1460, 1465, 1470, 1477. *Chem. Abstracts* **41** (1947), 3447.

Cryptomeriol

Years ago, Kimura¹ observed in the oil derived from Japanese cedar wood (*Cryptomeria japonica*) a sesquiterpene alcohol of unknown constitution which he named cryptomeriol and which had these properties:

b_{10}	162° – 163°
d	0.964
$[\alpha]_D$	$-37^{\circ} 5'$

Later, Kimura and Mizoshita² isolated from Japanese cedar wood oil (province Tosa, southern part of Shikoku Island) another sesquiterpene alcohol of unknown constitution which possessed these properties:

b_9	145° – 150°	$[\alpha]_D$	$-6^{\circ} 20'$
d_4^{25}	0.9657	n_D^{25}	1.5055

Compare also "Cryptomeradol."

¹ *Ber. deut. pharm. Ges.* **19** (1909), 369. Cf. *Ber. Schimmel & Co.* April (1910), 35.

² *J. Chem. Soc. Japan* **51** (1930), 518. *Chem. Abstracts* **26** (1932), 719.

Equinopanacol

Kariyone and Morotomi¹ observed in the volatile oil of *Echinopanax horridus* Deene et Planch. a new sesquiterpene alcohol which they named equinopanacol and which had these properties:

b_{11}	150° – 155°	$[\alpha]_D^{10}$	$+8^{\circ} 29'$
d_4^{10}	0.9022	n_D^{18}	1.48568

¹ *J. Pharm. Soc. Japan* No. 546 (1927), 671.

Maroniol

Jeancard and Satie¹ found in the oil derived from Guiana sandalwood a probably tertiary alcohol which they named maroniol and which had these properties:

b_{20}	158° – 159°
d_{23}	1.0378
α	$-6^{\circ} 0'$

Soluble in 1.6 vol. of 70% alcohol; soluble in 6.5 vol. of 60% alcohol.

¹ *Perfumery Essential Oil Record* **2** (1911), 79.

III. KETONES

Chrysantone

$C_{10}H_{16}O$

Mol. Weight 152.23

Takahashi¹ isolated from the volatile oil of *Chrysanthemum lavandulaefolium* Makino var. *typicum* Makino a new ketone $C_{10}H_{16}O$, viz. chrysantone b_{10} 75°–76°. The ketone could be characterized by the preparation of its semicarbazone m. 185°–186°, of the *p*-nitrophenylhydrazone m. 134°–135°, and of the 2,4-dinitrophenylhydrazone m. 115°–116°.

¹ *J. Chem. Soc. Japan* **54** (1933), 843.

Luparone

$C_{13}H_{22}O$

Mol. Weight 194.31

Chapman¹ isolated from the fraction b_4 87°–97° of hops oil a ketone $C_{13}H_{22}O$, viz., luparone, which had these properties:

b_3	74°–76°	$[\alpha]_D$	–0° 24'
d_{20}^{20}	0.8861	n_D^{20}	1.485

Semicarbazone m. 98°.

¹ *J. Chem. Soc.* (1928), 1303; **67** (1895), 54.

Ishwarone

$C_{15}H_{22}O$

Mol. Weight 218.33

Rao, Manjunath and Menon¹ observed in the volatile oil distilled from the roots of *Aristolochia indica* L. a colorless sesquiterpene ketone $C_{15}H_{22}O$, viz., ishwarone, which had these properties:

$b_{1.0}$	118°–120°	α_D^{30}	–46° 28'
d_{30}^{30}	1.0290	n_D^{30}	1.5122

Semicarbazone m. 240°.

p-Nitrophenylhydrazone m. 186.5°.

2,4-Dinitrophenylhydrazone m. 167.5°.

Isoxime m. 133°.

¹ *J. Indian Chem. Soc.* **12** (1935), 496.

IV. PHENOLS

Microl

$C_{13}H_{18}O_2$

Mol. Weight 206.27

This phenol was found by Ikeda¹ in the volatile oil of pha-chium or *Cinnamomum micranthum* Hayata, a tree resembling camphor and growing in Formosa. Microl has the following properties:

b_4	133°–136°
d_4^{30}	1.0113
n_D^{30}	1.5252

Phenylurethane m. 101°.

Naphthylurethane m. 116°–117°.

¹ *J. Chem. Soc. Japan* **51** (1930), 348. *Chem. Abstracts* **25** (1931), 3438.

Luparol

$C_{16}H_{26}O_2$

Mol. Weight 250.37

According to Chapman,¹ the fraction b_4 110°–150° of hops oil contains an optically inactive phenol $C_{16}H_{26}O_2$, viz., luparol, which has these properties:

b_2	122°–124°
d_{20}^{20}	0.9170
n_D^{20}	1.4942

¹ *J. Chem. Soc.* (1928), 1303; **67** (1895), 54.

V. LACTONES

Costus Lactone

Costusolactone

$C_{15}H_{20}O_2$

Mol. Weight 232.31

This bicyclic lactone containing two double bonds was found by Semmler and Feldstein¹ in the fraction b_{11} 200° – 210° (d_{21} 1.0749, α_D $+38^{\circ}$, n_D 1.53103) of costus root oil (*Saussurea lappa* Clarke). The lactone seems to be an isomer of alantolactone.

Costus lactone has these properties:

b_{13}	205° – 211°	n_D	1.53043
d_{21}	1.0891	Mol. refr.	Calc. 65.91
α_D	$+28^{\circ} 0'$		Found 65.85

The methyl ester of the corresponding hydroxy acid, on boiling, yields the original costus lactone.

On hydrogenation with platinum and hydrogen, costus lactone is converted into tetrahydrocostus lactone. (See "Dihydrocostus Lactone.")

¹ *Ber.* **47** (1914), 2433, 2687.

Dihydrocostus Lactone

Dihydrocostusolactone

$C_{15}H_{22}O_2$

Mol. Weight 234.33

This bicyclic sesquiterpene derivative was found by Semmler and Feldstein¹ in the fraction b_{11} 190° – 200° (d_{21} 1.0501, α_D $+44^{\circ}$, n_D 1.52703) of costus root oil (*Saussurea lappa* Clarke). It can be purified by converting the silver salt of the corresponding hydroxy acid into the methyl ester which on distillation *in vacuo* yields the original dihydrocostus lactone.

Thus purified, the lactone has these properties:

b_{19}	210° – 213°	n_D	1.52289
d_{22}	1.0776	Mol. refr.	Calc. 66.31
α_D	$+48^{\circ} 0'$		Found 66.31

On hydrogenation with platinum and hydrogen, dihydrocostus lactone, as well as costus lactone, yields the same tetrahydrocostus lactone $C_{15}H_{24}O_2$, b_{13} 198° – 202° , d_{21} 1.0451, α_D $+33^{\circ}$, n_D 1.50510, mol. refr. 66.71 (calc.), 66.99 (found).

Dihydrocostus lactone can be prepared by warming costus acid with 33 per cent sulfuric acid (see "Costus Acid").

¹ *Ber.* **47** (1914), 2433, 2687.

VI. MISCELLANEOUS COMPOUNDS

Tasmanol



Mol. Weight 226.31

Years ago Robinson and Smith¹ isolated from the volatile oil of *Eucalyptus risdoni* Hook. f., and *E. linearis* A. Cunn. a substance b. 268°–273°, b₂₅ 175°, d₂₃ 1.077, α_D 0°, n_D²² 1.5269, which they thought to be a phenol, viz., tasmanol. Previously, Baker and Smith² already had observed tasmanol in oil of *E. linearis* A. Cunn.

Years later, Trikojus and White³ investigated oil of *E. risdoni* and found that tasmanol is not a phenol, but probably an acid C₁₃H₂₂O₃ with the structure of a cyclohexene (or bridged cyclohexene) complex to which is attached a methyl ether and a carboxyl group (perhaps in aliphatic side chain), viz., C₆·(C₅H₁₈)·(OCH₃)·(COOH).

¹ *J. Proc. Roy. Soc. N. S. Wales* **48** (1914), 518.

² *Proc. Roy. Soc. Tasmania*, Oct. (1912), 19.

³ *J. Proc. Roy. Soc. N. S. Wales* **66** (1932), 279.

Cubeb Camphor

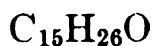

Mol. Weight 222.36

According to Gildemeister and Hoffmann,¹ oil of cubeb on prolonged exposure to air separates a laevorotatory compound (C₁₅H₂₆O) which melts at 68°–70° and boils at 248° with cleavage of water.

¹ "Die Ätherischen Öle," 3d Ed., Vol. I, 499.

Santal Camphor



Mol. Weight 236.34

The Schimmel chemists¹ found in the oil derived from South Australian sandalwood (*Santalum preissianum* Miquel) a compound C₁₅H₂₄O₂ which they named santal camphor. It melted at 104°–105°.

¹ *Ber. Schimmel & Co.*, April (1891), 49; Oct. (1891), 34.

Dimyristyl Carbinol

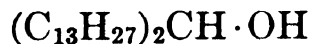

Mol. Weight 396.72

According to Gildemeister and Hoffmann,¹ the volatile oil derived from apples contains dimyristyl carbinol which melts at 81.5°–82°. Acetyl compound m. 44°–46°.

¹ "Die Ätherischen Öle," 3d Ed., Vol. I, 503.

Malol



Mol. Weight 456.68

According to Gildemeister and Hoffmann,¹ apple oil contains malol C₃₀H₄₈O₃ which melts on slow heating at 280°–282° but at 284°–285° on rapid heating. Diacetyl compound m. 199°–200°.

¹ "Die Ätherischen Öle," 3d Ed., Vol. I, 503.

THE PREPARATION OF DERIVATIVES OF
ESSENTIAL OIL CONSTITUENTS

by

FRANCES S. STERRETT, PH.D.

INTRODUCTORY NOTE

The monographs which comprise the preceding pages of this volume make frequent mention of derivatives employed for the identification of essential oil constituents, but without including, in every case, a detailed description of the methods by which such derivatives are prepared in the laboratory.

It is felt, therefore, that a compilation of the most important of these procedures, accompanied by a short explanation of the chemical reactions involved in them, may be of help to many workers in the essential oil field. Advanced researchers will, of course, be acquainted with these methods and reactions, which they will consider fundamental; but students and newcomers to the industry, and particularly chemists in remote producing regions where library facilities are limited, should derive considerable benefit from the following chapter, "The Preparation of Derivatives of Essential Oil Constituents."

Perhaps the chapter will also contribute to a broader understanding of the subject among that large body of researchers who tend to regard the chemistry of essential oils as a highly specialized study. With increased understanding should come wider experimentation. Many an interesting problem awaits solution! The young academic worker should find the field a most fruitful one for investigation.

ERNEST GUENTHER
DARRELL ALTHAUSEN

THE PREPARATION OF DERIVATIVES OF ESSENTIAL OIL CONSTITUENTS

Introduction.—This chapter is intended to serve as a guide in the preparation of crystalline derivatives useful for the identification of essential oil constituents. It may be considered a supplement to Part VII of Chapter 4 in Vol. I of this work (“A Procedure for the Investigation of the Chemical Constituents of an Essential Oil”). It will also supplement previous sections of the present volume, since it contains a more detailed discussion of the preparation of certain derivatives of essential oil constituents. Not all such derivatives will be discussed here, however, but only those which are sufficiently important to have been described repeatedly in the earlier sections of this volume.

In the preparation of this chapter the author has consulted not only the monographs in the preceding section of this volume, but also the following books:

- S. Mulliken, “A Method for the Identification of Pure Organic Compounds,” 1st Ed., John Wiley, New York (1904).
- K. Bournot, “Die Terpene” from “Handbuch der biologischen Arbeitsmethoden,” by E. Abderhalden. Urban and Schwarzenberg, Berlin and Vienna (1929).
- O. Kamm, “Qualitative Organic Analysis,” 2nd Ed., John Wiley, New York (1932).
- R. Shriner and R. Fuson, “The Systematic Identification of Organic Compounds,” 2nd Ed., John Wiley, New York (1940); 3rd Ed. (1948).
- E. Huntress and S. Mulliken, “Identification of Pure Organic Compounds,” John Wiley, New York (1941).
- Staff of Hopkin and Williams, “Organic Reagents for Organic Analysis,” Chemical Publishing Co., New York (1946).

There are many other standard works which deal with the identification of organic compounds and with the fundamental reactions involved; of these books the following should be mentioned here:

- J. Houben, “Die Methoden der organischen Chemie,” 3rd Ed., 4 Vols., G. Thieme, Leipzig (1925–1941); also Edwards Brothers, Inc., Ann Arbor, Michigan.
- H. Meyer, “Analysen und Konstitutionsermittlung organischer Verbindungen,” 6th Ed., J. Springer Verlag, Berlin (1939).
- F. Wild, “Characterization of Organic Compounds,” Cambridge University Press (1947); also The Macmillan Company, New York.
- S. M. McElvain, “The Characterization of Organic Compounds,” The Macmillan Company, New York (1947).

It should be noted, however, that none of the books mentioned above deals exclusively with the identification of constituents occurring in essential oils.

This chapter will present certain basic information necessary to the preparation of derivatives for the aliphatic, aromatic and terpenoid compounds found in essential oils. It is intended to supplement, rather than to replace, the excellent books mentioned above.

The arrangement of the constituents by chemical groups, employed in the preceding section on “The Constituents of Essential Oils,” is also followed here, beginning

with hydrocarbons and continuing with alcohols, aldehydes and ketones, phenols and phenol ethers, acids, esters, lactones and anhydrides, and other constituents.

This chapter will deal primarily with the preparation of derivatives of organic substances for the purpose of identification by melting point.

The methods of identification discussed are intended only for the qualitative determination of constituents. Certain derivatives may be useful also for the quantitative determination of substances occurring in essential oils; for further details the reader is referred to Chapter 4 in Vol. I.

Highly specialized identification methods, such as wave-length absorption, Raman effect, other spectrophotometric methods, polarographic methods, chemical microscopy might prove valuable for certain compounds, but will not be discussed in this chapter.

Color tests, which may be satisfactory in special cases cannot, in general, be used for the identification of compounds derived from natural products such as essential oils, in which the presence of impurities—often unavoidable—may lead to erroneous interpretations of results.

In general, before any derivative of an essential oil constituent can be prepared for identification purposes, the constituent must be separated from the oil and purified. Methods for separation are discussed in Part VII of Chapter 4 in Vol. I, and in previous sections of the present volume (see "Isolation" under the individual substances).

The purification and isolation of certain derivatives by the chromatographic method may prove adequate and practical at times. This method has been employed with azulene and coumarin derivatives, for example. No detailed discussion of it can be given here, however.*

In general, the identity of the isolated compound can be tentatively established on the basis of its physical properties (including odor) and of its method of isolation. Final identification should be effected by preparing a derivative and characterizing it by means of a mixed melting point determination with an authentic specimen. If the essential oil chemist has no clue as to the identity of the compound, he may be faced with a research problem.

It is generally advisable, therefore, in carrying out the preparation of a derivative to use a substance which has been highly purified.

Many reactions for the preparation of derivatives will take place readily only with chemically pure substances; crystallization, for example, may be greatly retarded, or even inhibited entirely, by the presence of impurities.

Since many of the constituents which occur in essential oils may be present as isomeric mixtures, it may be necessary to separate the isomers before undertaking identification. Even a small amount of an isomer may act as an impurity during the preparation of a derivative.

It should also be remembered that some compounds have more than one functional group, each of which may form a characteristic derivative. The position and nature of the functional groups within the compound will determine which functional group of the compound will yield the derivative most desirable for identification purposes.

In the attempt to prepare derivatives from terpenoids the organic chemist is often faced with great difficulties. Due to the complexity and peculiarity of the terpenoid molecule anomalous reactions often occur. Therefore, before attempting to prepare

* For general treatment of such method see: L. Zechmeister and L. Chohnoky, "Principles and Practice of Chromatography," translated by A. L. Bacharach and F. A. Robinson, John Wiley, New York (1941). H. H. Strain, "Chromatographic Adsorption Analysis," Interscience Publishers, New York (1941). T. I. Williams, "Introduction to Chromatography," Blackie and Son, London (1946).

the derivative of a substance, a thorough study of the original literature pertaining to the particular substance should be made. It is especially important for the researcher in terpenoid chemistry to anticipate experimental difficulties—possible impurities, formation of hydrates or other combinations with solvents, polymers or other reaction products which may be formed in small amounts, molecular rearrangements, dehydration, and isomerization.

An overwhelming number of derivatives of essential oil constituents has been reported in the last fifty years. Even compounds present in oils in small quantities have been identified through such derivatives. Since it has been impossible experimentally to verify all of the methods described in chemical literature, the author has had to rely upon that literature for much of her material. It is usual in a discussion of this kind to append tables of melting points of the various derivatives. The author has decided against including such tables for two reasons: in the first place there are frequently notable discrepancies in the melting points reported by various investigators for the same derivative; and, in the second place, there exist a large number of isomers in essential oils, such isomers yielding derivatives of different melting points. (Cf., for example, the tables of isomers and melting points of menthol derivatives, see p. 218.) Therefore, the reader will obtain a more objective picture if he consults the detailed monographs in the preceding sections, where the most important derivatives of individual constituents of essential oils are reported.

I. HYDROCARBONS

The saturated hydrocarbons found in essential oils are chiefly liquid and solid paraffins (waxes), and certain cycloparaffins. The preparation of crystalline derivatives of saturated aliphatic hydrocarbons is in most cases not feasible; therefore, identification is best achieved by physical methods.

However, most of the hydrocarbons occurring in essential oils belong to those terpenes * which possess at least one unsaturated linkage.

In general, the characterization of these unsaturated hydrocarbons is less difficult, since the double bond affords a point of reactivity.

The methods of preparing derivatives, which are most important to the essential oil chemist, will be discussed in the following order:

A. Oxidation

1. Dehydrogenation

B. Addition Products

1. Addition of Water (Hydration)

2. Addition of Hydrogen (Hydrogenation)

3. Addition of Hydrogen Halide

4. Addition of Halogen (Halogenation)

5. Addition of Nitrogen-containing Compounds

(a) Nitrosohalides

(b) Nitrosates

(c) Nitrosites

(d) Nitrolamines and Similar Compounds

6. Addition of Maleic Anhydride

7. Addition of Sulfuric Acid (Sulfonation)

8. Addition of Picric Acid and Related Substances

(a) Trinitrobenzene

(b) Trinitrotoluene (Trotylates)

(c) Trinitrophenol (Picric Acid)

(d) Trinitroresorcinol (Styphnic Acid)

A. OXIDATION

Hydrocarbons with an unsaturated linkage can, under certain mild experimental conditions, be oxidized to form a hydroxy derivative. This hydroxy derivative may be further oxidized to an aldehyde or ketone and, still further, to a carboxylic acid. Aromadendrene, sabinene, phellandrene, and terpinene, for example, upon oxidation may form glycols, ketones, or acids. Thujene, camphene, myrcene, carene may form a mixture of acids.

In many cases profound degradation will occur unless oxidation is carried out under carefully controlled conditions. Moreover, since the oxidation product may be unstable, exposure to the destructive action of the oxidant may cause its further oxidation. For example, in the preparation of a glycol, the oxidation process may easily be carried too far and may yield an acid.

* The term terpenes is used here in its broad sense and includes the sesquiterpenes and diterpenes.

Another factor influencing oxidation, and one which may sometimes retard it, is the insolubility of hydrocarbons in aqueous solution. It is, therefore, often advisable to use solvents such as acetone instead of water.

One of the most common and most useful agents employed in organic oxidation is potassium permanganate. It functions as an oxidizing agent of different strength in *alkaline*, *neutral*, and *acid solutions*. When potassium permanganate is used in aqueous solution, the solution becomes *alkaline* through the formation of potassium hydroxide:



It is often essential to wash the manganese dioxide thoroughly to extract any adhering oxidation products. After removal of the manganese dioxide the acid may be recovered by acidification. The separation of the acid by an insoluble salt (such as the silver, lead or mercury salt) may be indicated in certain cases.

In a few cases, to expedite oxidation, the use of *neutral* potassium permanganate solution is advisable. To neutralize the alkali formed, the chemist may introduce carbon dioxide, or he may employ magnesium sulfate, which will form neutral potassium sulfate and insoluble magnesium hydroxide.

The *acid* solution resulting from the addition of acetic acid or sulfuric acid to potassium permanganate solution yields a powerful oxidizing agent and is rarely used for the oxidation of essential oil constituents.



For an example of cautious permanganate oxidation, the reader is referred to the discussion of "Terpinolene" (p. 30). The methods reported are those of Wallach,¹ and Briggs and Sutherland.² Another example of mild oxidation will be found on page 36, a method employed by Wallach³ for oxidation of α -terpinene.

Two examples of oxidation in neutral solution are described on pages 58 and 17. The first is the method of Thurber and Roll⁴ employed in the oxidation of α -pinene; the second is that of Wallach⁵ applied to *p*-cymene.

Chromic acid and sodium or potassium dichromate are frequently employed as oxidizing agents. The usual oxidation is carried out with dichromate in the presence of sulfuric acid (see "Bisabolene," p. 86).

The Beckmann mixture is often mentioned in connection with the oxidation of constituents of essential oils (see " α -Terpinene," p. 37 and " Δ^3 - and Δ^4 -Carene," pp. 51 and 52); this mixture consists of a solution of 60 parts of potassium dichromate, 80 parts of concentrated sulfuric acid, and 270 parts of water.

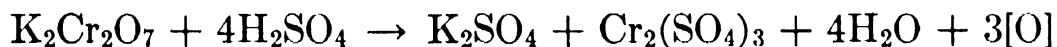

Chromic anhydride (CrO_3) dissolved in glacial acetic acid is sometimes used as an oxidizing agent (see "Gurjunene," p. 120).



Ozone is used for the purpose of degradation, in which process the molecule splits at the double-bond position. Such oxidation is especially important for the determination of molecular structure; for example, to establish the presence of methylene and isopropylidene groups.

If nitric acid is employed for oxidation, great care must be taken to prevent nitration. Even when dilute solutions of nitric acid are used, the products of oxidation may contain nitro derivatives; for example, camphene with dilute nitric acid forms a nitro derivative (see p. 67).

As can readily be seen from the above discussion, the variations in the technique employed may yield such divergent end products that identification by oxidation of a given compound may become a major problem. The author cannot, therefore, sufficiently emphasize the importance of consulting the original literature⁶ and following exactly the specific procedure therein outlined.

1. Dehydrogenation.—Dehydrogenation can be used for identification purposes when the dehydrogenated product is a solid, or when the latter forms derivatives more readily than the substance being examined. For example, no crystalline derivatives have been reported for isocadinene, which, however, upon dehydrogenation, yields cadalene, from which it is possible to prepare crystalline derivatives. Vetivene, calamene, zingiberene, and isozingiberene also form cadalene upon dehydrogenation with sulfur (see p. 81). However, many other sesquiterpenes (for example, eudesmol and selinene) form eudalene upon dehydrogenation. The difference in color which results from the use of various dehydrogenating agents, that is, sulfur and selenium, is often of value in the identification of azulenic compounds.

B. ADDITION PRODUCTS

1. Addition of Water (Hydration).—When used in connection with the identification of organic compounds occurring in essential oils, hydration may generally be considered as the addition of the elements of water to a double bond.

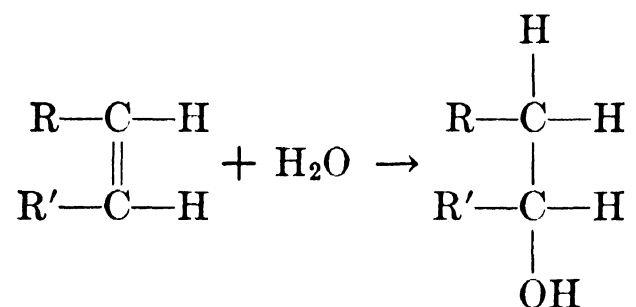

The products resulting from hydration alcohol.

Being alcohols, they offer a possibility of further identification by the formation of characteristic derivatives of alcohols, such as urethanes. Certain hydration products are actually tertiary alcohols, but are nevertheless referred to as "hydrates," even though they contain no water of hydration in the molecule (for example, santene hydrate, camphene hydrate). A typical example of a substance containing water of hydration is terpin hydrate, in which a molecule of water is added to the glycolic substance, terpin. If these hydration products, or so-called hydrates, have a well-defined melting point, they may be used for identification purposes (for example, in the case of the caryophyllenes and santalene).

Direct hydrations are carried out with solutions of acid. With certain compounds mere shaking of the substance with a dilute acid solution will effect hydration; with others it may be necessary to heat on the steam bath for several hours.

Some terpenes, however, are so unstable that, on being acted upon by acids, they are converted into isomers without forming separable hydration products (phellandrene is such a terpene). Other terpenes form hydration products only under controlled conditions. For example, if optically active limonene is treated in the cold with acids, hydration to terpineol and terpin hydrate will frequently result. If heated with mineral acids, it may be converted into terpinene and *p*-cymene (see p. 25).

The hydrates of santene and selinene are prepared indirectly from the hydrohalide by the action of a solution of calcium hydroxide (see pp. 80 and 108).

In some cases it may be possible, by the action of acid, to obtain an isomer of the

hydration product: camphene, for example, when hydrated usually forms isoborneol and some borneol; it forms camphene hydrate only as an intermediate product. For the formation of camphene hydrate, see below. Similarly, hydration of cyclofenchene will produce isofenchyl alcohol.

Some hydration products, being alcohols, may esterify with the acids used for the hydration: α -fenchene, upon hydration with glacial acetic acid and sulfuric acid, yields isofenchyl acetate (p. 71).

Ruzicka and Stoll⁷ reported that cadinene is not altered when digested with a 10 per cent sulfuric acid solution in alcohol, but when treated with the Bertram-Walbaum mixture is isomerized to isocadinene.

The Bertram-Walbaum reagent consists of a mixture of acetic acid and a small amount of dilute sulfuric acid. For the hydration of camphene, Bertram and Walbaum⁸ recommended the use of 250 parts of glacial acetic acid and 10 parts of 50 per cent sulfuric acid. The mixture is added to 100 parts of the hydrocarbon and the whole solution then warmed for hydration purposes. Under these conditions camphene will yield chiefly isobornyl acetate. The Bertram-Walbaum method is often used for the hydration of terpenes such as santene (p. 80), caryophyllene (p. 102), ocimene (p. 11), etc. (A more detailed procedure for this method will be found on pp. 67 and 102.)

Aschan⁹ carried out hydration reactions with a mixture of equimolar amounts of absolute ether and sulfuric acid monohydrate. He advanced the hypothesis that the catalytic action of the diethyloxonium sulfate in the mixture results in the formation of oxonium salts.

The experiment he carried out on camphene proceeded as follows:

About 1 mol of sulfuric acid monohydrate was cooled in an ice mixture, then added dropwise, with stirring, to 1 mol of absolute ether. Ten per cent less than the molar equivalent of the camphene was divided into three portions. Each portion was then added separately to the mixture. After each such addition the temperature was allowed to rise somewhat. The first portion was added to the cooled mixture; the second portion was added at a somewhat higher temperature, but below 20°; the last portion was added at room temperature, and the mixture allowed to stand for some time. The reaction mixture was then added gradually to a saturated solution of sodium carbonate in contact with excess solute. Two layers formed. The ether layer was separated and the water layer washed twice with ether. The camphene hydrate was then steam distilled from the water layer.

Aschan¹⁰ also prepared camphene hydrate by the use of equimolar quantities of sulfuric acid and ether. By the action of the Aschan reagent upon santene, dipentene, and α -pinene, isomerization products were obtained (see Aschan¹¹).

Asahina and Tsukamoto (p. 102) used the Aschan reagent successfully for the preparation of caryophyllene alcohols.

2. Addition of Hydrogen (Hydrogenation).—Hydrogenation products will prove useful for the identification of a compound if either the hydrogenated product itself is a known solid—with a well-defined melting point—or if the hydrogenated product readily yields a characteristic derivative which cannot be prepared from the original compound under examination.

In some cases hydrogenation leads to molecular rearrangement and results in formation of substances of different ring structure. β -Pinene, for example, changes to the isomeric α -pinene upon hydrogenation (see p. 63).

The experimental conditions required for hydrogenation vary greatly. In certain cases, especially when a system of conjugated double bonds is present, the hydrogen formed by the reaction of sodium with alcohol may suffice to hydrogenate a particular

substance—for example, β -myrcene (p. 8) or zingiberene (p. 88). In most cases, however, hydrogenation is more complicated, and special experimental conditions are required. In many instances, hydrogenation can be easily effected in the presence of such catalysts as nickel, nickel-containing alloys (such as Raney nickel), or various types of platinum and palladium catalysts. When hydrogenation is slow, the use of hydrogen under pressure may be indicated, but this will depend upon the nature of the compound itself.

Hydrogenation is too complex a procedure to be discussed in more detail here. The reader, therefore, should consult the original literature. A voluminous patent literature on the subject also exists.

3. Addition of Hydrogen Halide.—Many terpenes form characteristic solid addition products with hydrogen halides. When such addition compounds have well-defined melting points, they are particularly useful for the identification of certain terpenes.

Many hydrogen halide addition products decompose easily, with regeneration of the original terpene. This offers a convenient method for the isolation and purification of numerous terpenes. Compounds which may be isolated in this way include α -terpinene, cadinene, bisabolene, sylvestrene, santene, and selinene. The hydrogen halide addition product most frequently employed for the identification of terpenes is the *hydrochloride*.

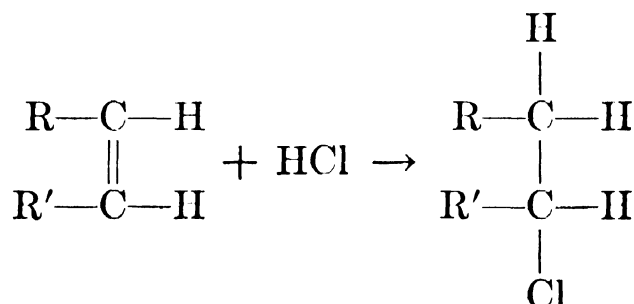

Reactions involving the addition of hydrogen halides or halogens are almost always exothermic and are, therefore, usually carried out at low temperature.

Not all terpenes yield crystalline hydrogen chloride addition products (isocadinene and α -caryophyllene, for example). This fact may be of value for distinguishing certain isomeric forms, for example, isocadinene and cadinene (p. 96), and α -caryophyllene and β -caryophyllene (p. 103).

In the terpene series the addition of hydrogen halides to double bonds is often accompanied by rearrangement of the ring system; this is true in the cases of β -phellandrene, zingiberene, carene, sabinene, bisabolene, sumbulene, and others.

The transformation and intramolecular rearrangement of terpenes, such as pinene and camphene, were studied by Wallach and by Meerwein and van Emster,¹² and more recently have been reviewed thoroughly by Hückel.¹³ On treatment with the theoretical quantity (no excess) of hydrogen chloride, camphene will usually form true camphene hydrochloride, whereas on treatment with an excess of hydrogen chloride, it will be converted to isobornyl chloride, which product will be obtained also if camphene hydrochloride is further treated with gaseous hydrogen chloride. The parent hydrocarbon (i.e., camphene) can be regenerated from camphene hydrochloride, as well as from isobornyl chloride, if either one of these chlorides is treated with alkali.

A method of preparing terpene hydrochloride addition products follows; it may be employed with β - and γ -caryophyllenes, camphene, α -terpinene, myrcene, zingiberene, bisabolene, sylvestrene, camphorene, santene, and selinene:

Dry hydrogen chloride gas is introduced at low temperature (usually at 0°) into a solution of hydrocarbon in absolute ether (usually 1:1 or 1:2). The hydrocarbon

is saturated with the hydrogen chloride, generally by using 2 mols of HCl to 1 mol of the hydrocarbon. The ether is then removed by evaporation, and the residue recrystallized, or separated under suction, washed with cold alcohol, and recrystallized from a suitable solvent, such as absolute alcohol.

Other solvents used in the preparation of hydrogen chloride addition products include chloroform (suggested for bornylene, see p. 77), alcohol (recommended for β -phellandrene, p. 48), and acetic acid (see below).

It is important to carry out the reaction under absolutely anhydrous conditions, since otherwise a molecular rearrangement may take place. For example, Δ^3 -carene can be converted into different addition products, depending upon whether it is treated with anhydrous hydrogen chloride or with aqueous hydrochloric acid (see p. 51). The true hydrochloride usually forms when *dry* hydrogen chloride gas is employed.

Another procedure for the preparation of hydrogen halides consists in using glacial acetic acid as solvent.

The glacial acetic acid solution is saturated with the hydrogen halide. This solution is added to a mixture of hydrocarbon in glacial acetic acid. The mixture is then poured into ice water. The addition product will generally precipitate immediately and can be separated and recrystallized.

This procedure can be followed not only in the preparation of the hydrogen chloride compounds, but in the preparation of other hydrogen halide addition products—such as *hydrogen bromides* and *hydrogen iodides*. (See “Cadinene,” p. 93.)

To *regenerate* the hydrocarbon from the addition product the following methods (among others) have been suggested:

(a) Heating of the addition product with aniline (see “ α -Terpinene”—Isolation, p. 35). Ten grams of the terpene dihydrochloride are heated with 20 cc. of aniline until the reaction starts. Then 20 cc. of glacial acetic acid are added and the mixture steam distilled. The distillate, which contains considerable quantities of aniline, is shaken with oxalic acid solution. The hydrocarbon is again driven off from the acid solution by steam distillation, the distillate is shaken once more with oxalic acid, and the process repeated until the distillate is absolutely free from aniline. The hydrocarbon can then be separated, dried, and distilled over metallic sodium.

Dipentene and santene have also been regenerated from their hydrochlorides with aniline.

Other amines such as diethylaniline may be used in place of aniline as a regeneration agent (see sylvestrene, p. 32).

(b) Boiling of the addition product with sodium acetate in glacial acetic acid. Bisabolene and sylvestrene, for example, have thus been recovered. This method often gives better results.

(c) Treating of the addition product with alkali. Potassium hydroxide in methyl alcohol may be used (see “Selinene,” p. 109); or a 10 per cent solution of potassium hydroxide in ethyl alcohol (see “Camphorene,” p. 127); or sodium alcoholate (see “Cadinene,” p. 92).

It should be remembered that hydrogen halide addition products may serve also for the identification of compounds other than hydrocarbons, such as certain alcohols, ketones, and acids. For the preparation of these products, the reader is referred to the preceding sections of this volume in which the individual substances are discussed.

4. Addition of Halogen (Halogenation).—Halogen reaction products, often referred to as halides, are useful for the identification of many hydrocarbons, as well as of some oxygen-containing compounds, such as certain alcohols, phenols, ketones, aldehydes, and acids. In the present section chiefly the hydrocarbon halides will be considered.

Two kinds of reaction may take place between a hydrocarbon and a halogen: *addition* or *substitution*.

The latter is always accompanied by the formation of halogen acid. Therefore, in the usual laboratory procedure, an addition reaction is indicated by the decolorization of the bromine solution, without the formation of hydrogen bromide.

Many hydrocarbons, especially those of the terpene series, form well-defined crystalline derivatives upon the addition of halogen—for example, myrcene, ocimene, styrene, dipentene, limonene, terpinolene, terpinene, fenchene, longifolene, hecra-bolene, and others. In the presence of certain so-called negative groups (phenyl, carbonyl, etc.), the addition reaction of bromine may be very slow.

Two examples of substances containing such negative groups are diphenylethylene and cinnamic acid. In both of these the negative groups are bound to an ethylenic bond.

It should be remembered that steric effects may also decrease the speed of reaction.

Of the halogens, iodine is used mainly for the quantitative determination of unsaturation in organic compounds (see "Iodine Number," Vol. I, p. 305); whereas bromine serves chiefly for the qualitative determination of unsaturation. Iodine, bromine, and chlorine in many cases form addition products with essential oil constituents and may therefore be employed for the identification of the latter. Bromine is more frequently used for this purpose than iodine and chlorine and will be discussed more fully here.

Halides may be of the mono- or poly- type, depending upon the experimental conditions and the substances employed. Of these, the tetrabromides constitute the most important group for the identification of terpenes (although it should not be forgotten that a single compound may form several types of halides).

Wallach¹⁴ suggested the following method for the preparation of *tetrabromides*:

One volume of terpene is diluted with 4 volumes of ether and cooled in an ice mixture; 0.7 volume of bromine are added dropwise to the mixture, at low temperature. After all the bromine has been added, the ether is evaporated. In the case of pure terpenes—which are capable of forming solid tetrabromides—separation of crystals usually starts within a few minutes. The mixture is allowed to stand 1 to 2 hr. The crystals are then separated, if necessary washed with cold alcohol, and recrystallized from ether.

The use of alcohol as a solvent for the bromination of terpenes is recommended, since bromine reacts much more readily with terpenes than with alcohols, so that the alcohol does not interfere in the reaction. Furthermore, the tetrabromides formed are almost insoluble in cold alcohol, which is at the same time a good solvent for the oily impurities (by-products always formed along with the solid compound, in many cases in large quantities).

It should be emphasized here that an excessive formation of oily by-products considerably retards the crystallization of the solid tetrabromides and, in some instances, inhibits it entirely. It is also of importance to use completely anhydrous reagents, which may help to minimize the formation of oily products. Allowing the oily mass to stand in the cold for a long time (sometimes for several weeks) may also induce crystallization.

In certain cases the addition of bromine may take place very smoothly when the terpene is diluted with ten times its weight of glacial acetic acid. Ethyl acetate is a good solvent for recrystallization of the tetrabromide.

In connection with the preparation of limonene tetrabromide, page 24, Baeyer¹⁵ obtained crystalline tetrabromides by brominating the terpene fraction in a solution of equal parts of amyl alcohol and ether, then evaporating the ether slowly. Godlevski¹⁶ recommended adding a mixture of the terpene and equal parts of amyl alcohol and ether, dropwise, to an ice-cold solution of bromine in ether. The mixture must be kept ice cold throughout the reaction. Gaponenkov¹⁷ has recently stated that the reaction is best carried out by reversing this order of addition, although using the same solvents (p. 24). Berry¹⁸ has also reported on the preparation and characteristics of certain terpene tetrabromides.

For the preparation of the *dibromide* of styrene, the following procedure has been recommended (see p. 14):

To a solution of 48.5 g. (1 mol) of freshly distilled styrene in 400 cc. of pure ether, add 126.8 g. of bromine dissolved in 600 cc. of ether. Place the solution of styrene in an open beaker surrounded by ice water and keep in motion with a mechanical stirrer. Regulate the rate of flow of the bromine in solution by the change in color, from red to a very light yellow. The entire operation is most advantageously carried out in direct sunlight. The crude product obtained by distilling off the ether is purified by recrystallization from alcohol.

It is also possible that upon bromination, certain unstable terpenes isomerize in the course of the reaction—cyclofenchene, for example, when treated with bromine, forms α -fenchene dibromide (see p. 74).

In the preparation of the chlorides, chlorinating agents such as phosphorus pentachloride, and antimony trichloride, may be more effective than chlorine itself.

Iodine can be employed for the preparation of addition compounds in a manner similar to bromine. For the identification of constituents in essential oils, iodides, however, are used only infrequently.

5. Addition of Nitrogen-containing Compounds.—Many unsaturated hydrocarbons, especially those of the terpene series, form crystalline addition products with nitrosohalides and with the acids corresponding to the various oxides of nitrogen.

(a) *Nitrosohalides.*—The nitrosochloride addition compounds are those most frequently reported in literature. They are usually formed by the addition of nitrosochloride to a double bond:

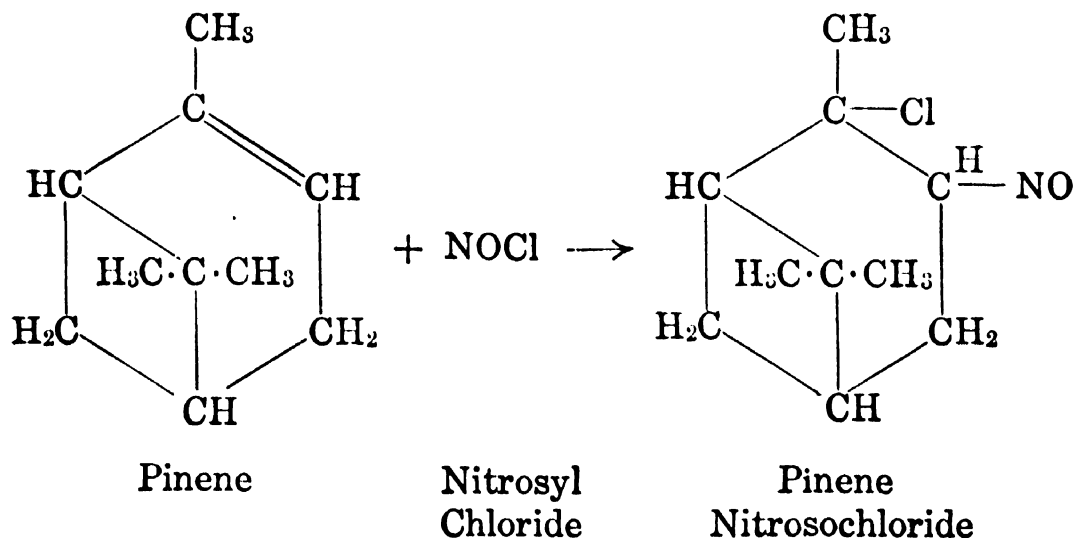

If the carbon atom attached to the nitroso group ($-\text{NO}$) is also attached to a hydrogen atom, transformation into the isomeric oxime may take place. In literature the nitrosochlorides are frequently presented in the oxime form:

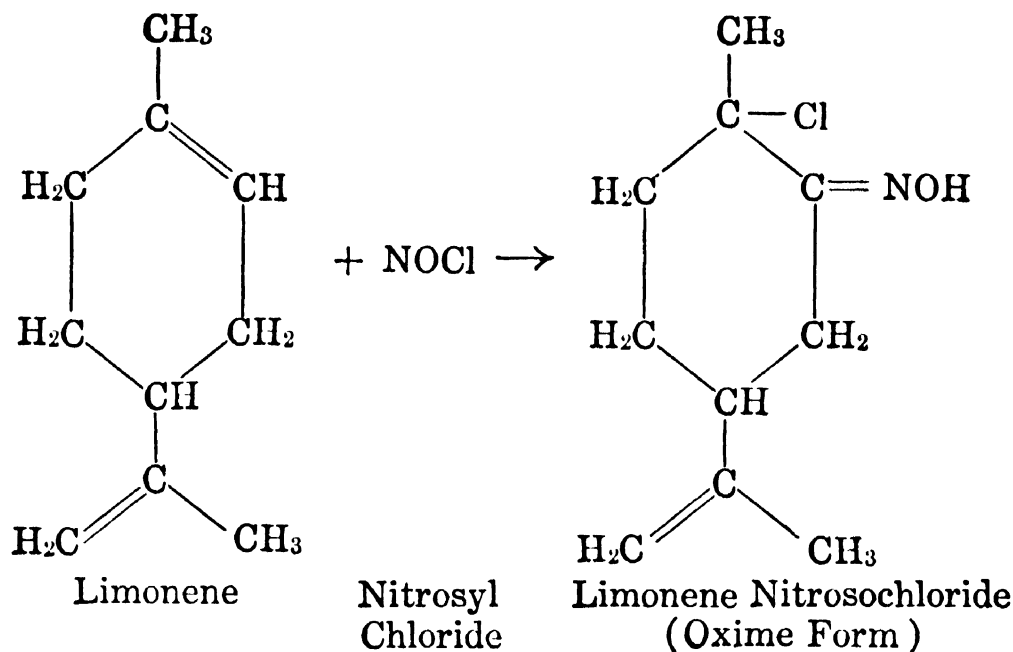

The nitrosochloride may exist in a bimolecular form; according to Simonsen,¹⁹ the actual nature of the linkage between the two molecules has not been established.

Terpenes forming crystalline nitrosochlorides include limonene, dipentene, sylvestrene, phellandrene, carene, pinene, fenchene, santene, humulene, zingiberene, cadinene, caryophyllene, santene, and also the alcohol terpineol.

Nitrosochloride addition products are formed by the action of nitrosylchloride (NOCl) in a nascent state upon terpenes, generally in the presence of solvents such as acetic acid or alcohol. For example: (1) hydrochloric acid may be added dropwise to a well-cooled solution consisting of ethyl nitrite (or preferably amyl nitrite), glacial acetic acid, and the terpene; or (2) a gaseous mixture of hydrogen chloride and nitrous anhydride may be conducted into the well-cooled solution of the terpene and solvent.

After the addition product is formed, separation may best be effected by pouring the solution into cold water.

Wallach (see p. 57) suggested the following method for the preparation of (optically inactive) α -pinene nitrosochloride:

A mixture consisting of 50 g. of the terpene, 50 g. of glacial acetic acid and 50 g. of ethyl nitrite (or amyl nitrite) is cooled well. Fifteen cubic centimeters of hydrochloric acid (32–33 per cent) are added dropwise. The nitrosochloride addition product soon separates in crystalline form and may be obtained in a fairly pure state upon filtering and washing with alcohol. From the filtrate more nitrosochloride may separate on standing in the cold.

Acetone may be particularly suitable as solvent for the recrystallization of nitrosochloride addition products.

The ethyl nitrite * may be prepared as follows:

Two hundred and fifty grams of sodium nitrite are dissolved in 1 liter of water, placed in a large distilling flask equipped with a well-cooled condenser, and 100 g.

* Great care must be exercised in the preparation of this reagent, because of the possibility of explosion. The reagent is best stored in a refrigerator.

of alcohol are added. To this solution a mixture of 200 g. of concentrated sulfuric acid, 1.5 liters of water, and 100 g. of alcohol are added very slowly. The liberated nitrous acid reacts immediately with the alcohol, forming volatile ethyl nitrite (b. 88.7°), which may be distilled off steadily as it forms. If the operation is properly conducted, 100% of the alcohol employed is transformed into ethyl nitrite, which may be used as reagent in the preparation of nitrosochlorides without further purification.

Ethyl or amyl nitrite may be used as a reagent for the preparation of nitrosochlorides of pinene or limonene. However, a preferable method, according to Rupe,²⁰ consists in the introduction of a gaseous mixture of nitrous anhydride and hydrogen chloride directly into the terpene-containing solution. This latter method is said to give a higher yield.

A crystalline mass of sodium chloride and concentrated hydrochloric acid is placed in a flask, and a saturated solution of sodium nitrite, and concentrated sulfuric acid simultaneously are added dropwise. These solutions are best introduced into the flask in a ratio of 2 volumes of sulfuric acid to 3 volumes of sodium nitrite; this ratio should prevent formation of excess hydrogen chloride. It is best to pass the gas mixture first through an empty gas-washing bottle and then through a gas-washing bottle filled with calcium chloride, both bottles being well cooled in an ice and salt mixture. This gas mixture may then be introduced into the reaction flask containing a well-cooled mixture of equal volumes of the terpene and ether, and half a volume of glacial acetic acid. The first color of the solution should be light green, changing to bluish-green; this serves as an indication that the proportion of gases is favorable to the desired reaction. A brownish color, on the other hand, indicates an excess of nitrogen oxides; a dark green indicates the presence of an excess of hydrogen chloride. The latter should especially be avoided, since it will prevent formation of a solid nitrosochloride, and only a green oil will be obtained. In order to obtain good yields it is advisable to keep the temperature low—a condition most easily achieved when working with small quantities.

Ehestädt recommended a similar method for the preparation of terpene nitrosochlorides (see p. 57).

Several modifications of the above methods have been suggested. Ahlström and Aschan (see p. 57) advised saturating a mixture of the terpene, glacial acetic acid, and ethyl nitrite with dry hydrogen chloride gas.

Thurber and Thielke suggested using a mixture of hydrochloric acid in 90 per cent methyl alcohol (5 N). Employing the amount of hydrochloric acid theoretically necessary, this mixture is added to a solution of 40 cc. of α -pinene, 40 cc. of 90 per cent methyl alcohol, and 40 cc. of ethyl nitrite. The separated nitrosochloride is recrystallized from a mixture of chloroform and methyl alcohol (for further details, see p. 56).

Similar procedures for the preparation of phellandrene nitrosochloride were recommended by Francesconi and Sernagiotto, and by West (see pp. 47 and 44).

In the case of α -pinene nitrosochloride, Ehestädt,²¹ modifying Wallach's procedure, suggested adding 1½ parts of the theoretically necessary quantity of 32 per cent hydrochloric acid dropwise to a concentrated solution of sodium nitrite. The gases generated are then conducted into a well-cooled ethereal solution of α -pinene (1:1).

In the case of pinene nitrosochloride, the addition product may be decomposed and α -pinene regenerated. According to Wallach (p. 55), this may be accomplished by boiling the nitrosochloride with aniline in alcoholic solution.

Certain nitrosochlorides—such as those of limonene, dipentene, and terpineol—may be converted into oximes by the action of alkali, for example, on boiling with alcoholic potassium hydroxide.

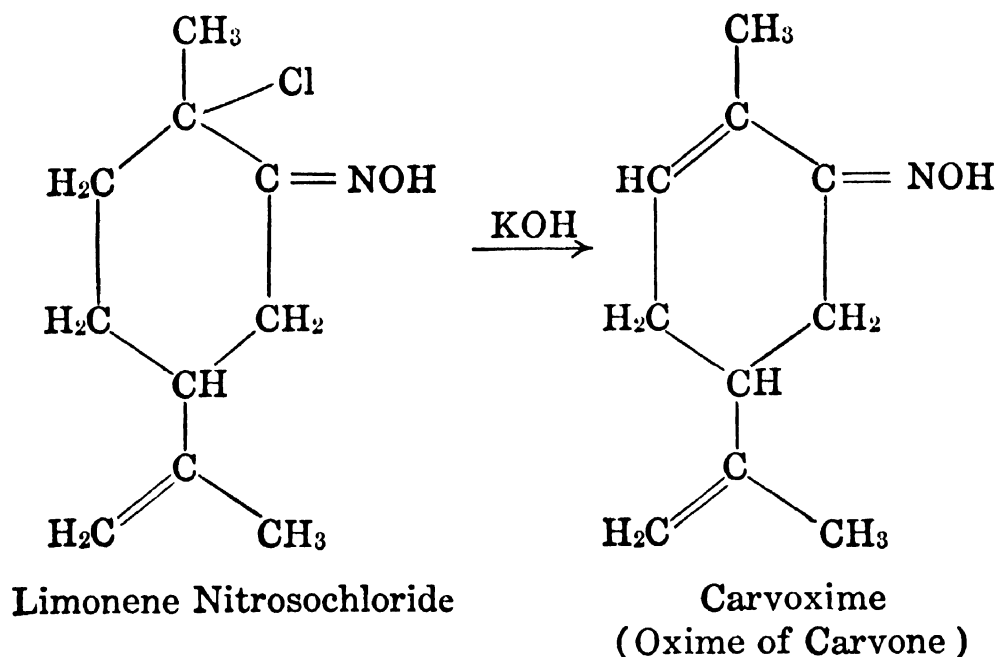

(b) *Nitrosates*.—Nitrosates are characteristic addition products containing N_2O_4 in the molecule. These compounds contain a $-\text{NO}$ group (similar to the nitrosochlorides) and, in addition, a $-\text{ONO}_2$ group attached to an adjacent carbon atom. These addition products have been prepared among others from limonene, dipentene, caryophyllene, Δ^3 -carene, fenchene, zingiberene, humulene, curcumene, cadinene, and also terpineol.

Wallach²² prepared these characteristic addition products by heating a solution of equal volumes of the terpene and amyl nitrite with 0.5 volume of glacial acetic acid and 1 volume of nitric acid (d 1.395) in the cold with shaking. After the addition of alcohol, the nitrosate will separate as an oil which often solidifies completely only after being cooled to a very low temperature (solid CO_2).

According to Wallach, the nitrosochlorides and nitrosates are useful for the identification of unsaturated compounds only in so far as their lesser solubility permits the separation of the terpenic compounds in question. Generally, however, the nitrosates and nitrosochlorides are less suited for final identification, because many of them possess melting points lying within a very close range; or melting points not sufficiently sharp to constitute a means of exact determination. The latter is true also of certain nitrosites (see "Phellandrene," p. 42). Consequently, it is important to confirm the identity of a terpene derivative by a mixed melting point determination with an authentic specimen.

(c) *Nitrosites*.—Nitrosites are characteristic addition products containing N_2O_3 in the molecule. These compounds contain a $-\text{NO}$ group (similar to the nitrosochlorides) and, in addition, a $-\text{ONO}$ group attached to an adjacent carbon atom (cf. "Nitrosates").

In the so-called *pseudonitrosites* the $-\text{ONO}$ group is probably present as a $-\text{NO}_2$ group.

The nitrosites of many terpenes are reported to exist in the oxime form (for example, α -terpinene nitrosite, according to Wallach²³) or sometimes in the bimolecular form, according to Simonsen.²⁴

Occasionally the nitrosites are called *nitrites*, since they contain the oxynitroso group $-\text{ONO}$. They have been obtained from phellandrene, myrcene, terpinene, bornylene, santene, zingiberene, humulene, orthodonene, caryophyllene, and others.

For the preparation of nitrosites, the introduction of nitrous acid directly into solutions of the terpene and the solvent is sometimes recommended (see "Caryophyllene," p. 102).

According to Bournot,²⁵ the best procedure is the following:

The hydrocarbon is first dissolved in petroleum ether, and a concentrated aqueous solution of sodium nitrite is added. Glacial acetic acid is introduced to form nitrous acid and the whole mixture well cooled and shaken. The entire mixture is then allowed to stand for several days in the cold.

The separated crystals decompose more or less readily, depending on the nature of the substance employed. The crystals are best separated in the cold and recrystallized. It may, in some cases, be advisable to add a particular solvent to the mixture right from the start, the solvent being chosen for its usefulness in maintaining, in solution, all those substances which tend to inhibit crystallization.

In the case of phellandrene, the reaction proceeds most rapidly and smoothly in the presence of petroleum ether at low temperatures. The reaction with terpinene is somewhat slower and is best carried out in glacial acetic acid at comparatively higher temperatures. It may be often necessary to seed the mixture to induce crystallization.

Similar procedures have been reported for the preparation of α - and β -phellandrene nitrosites (see pp. 42 and 46) and for α -terpinene nitrosite (Wallach,²⁶ see p. 36).

Acetone, methyl alcohol, and ethyl acetate may be used as solvents for recrystallization.

Certain nitrosites are photolytic and thermosensitive; this is particularly true of the caryophyllenes (see p. 101).

(d) *Nitrolamines and Similar Compounds*.—Various organic bases, such as alkyl or aryl amines, react with nitrosochlorides, nitrosites, and nitrosates to yield crystalline compounds which may serve for the identification of many terpenes and terpene derivatives. Bases used for this reaction are methylamine, ethylamine, propylamine, amylamine, etc. Benzylamine, aniline, and piperidine, sometimes even ammonia, may give good results. In this reaction, amines form nitrolamines; aniline yields nitrolanilines; etc.

According to Wallach,²⁷ the acid radical ($-\text{Cl}$; $-\text{ONO}$; $-\text{ONO}_2$) of the nitrosochloride, nitrosite, or nitrosate reacts with the organic base or ammonia:

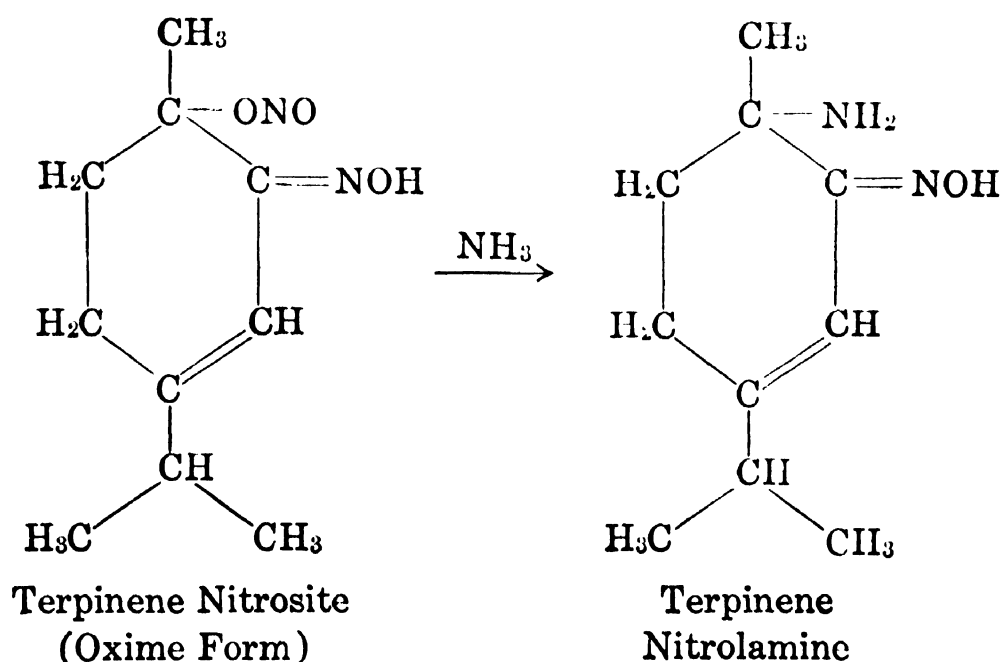

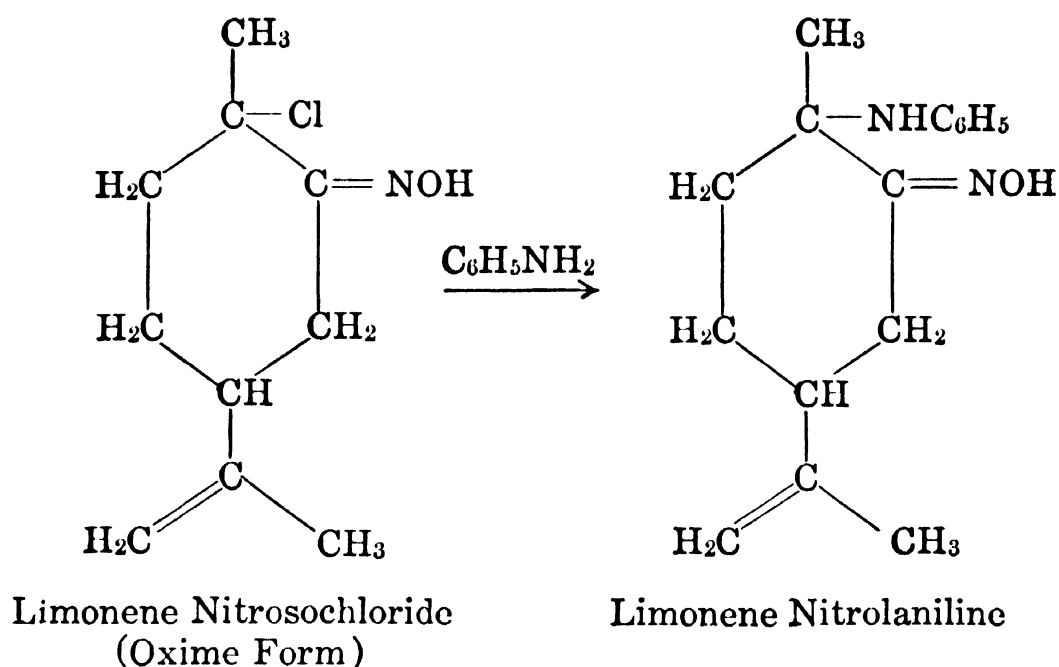

Wallach recommends the following procedure:

One mol of the nitrosochloride or the nitrosate is covered with alcohol and 2 mols of organic base are added and warmed slightly to dissolve the mixture. (A violent reaction often results.) On completion of the reaction the mixture is diluted with water and allowed to crystallize. After cooling, the compound usually precipitates completely. The separated compound is again dissolved in a small amount of cold glacial acetic acid, the solution is diluted with water, the product separated from non-basic constituents by filtration, and the nitrol compound precipitated with ammonia.

A characteristic property of these nitrolamines is that, in the course of separation, they are at first a sticky, spongy mass, becoming crystalline only after several hours or sometimes days.

Some nitrosochlorides are rather unstable and the preparation of their more stable nitrolamines may, therefore, be an advantage (see " Δ^3 -Carene," p. 50).

Certain nitrosites cannot be converted into their nitrolamines (see "Phellandrene," p. 43).

Nitro Compounds.—These compounds possessing an $-\text{NO}_2$ group are very rarely prepared for the purpose of identifying hydrocarbons occurring in essential oils. The same is true of nitroso compounds, other than those described above.

6. Addition of Maleic Anhydride.—The addition reaction between a substance containing an ethylenic bond and a substance possessing conjugated double bonds was named by Diels²⁸ the "Diene Synthesis." Diels and Alder in numerous experiments investigated possible variations of this synthesis.

The reagent most frequently employed for the substance containing an ethylenic bond is maleic anhydride.

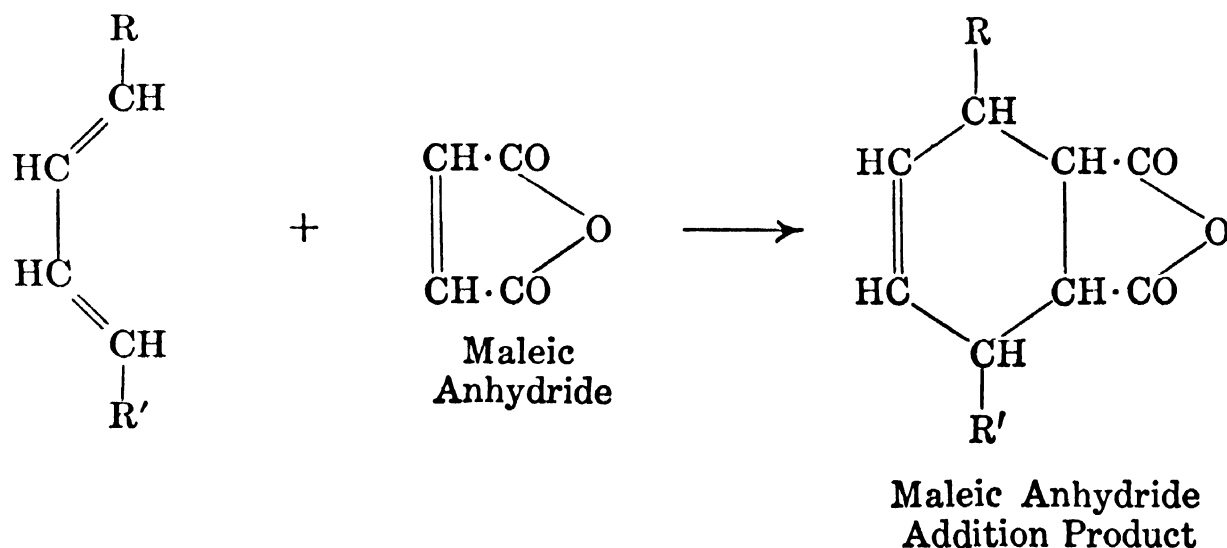

In addition to maleic anhydride, other substances possessing ethylenic components are often used in this type of reaction—for example, acrolein, crotonaldehyde, and acetylene derivatives (such as acetylene dicarboxylic esters).

Many compounds occurring in essential oils possess conjugated double bonds and may therefore be identified by their reaction products resulting from the diene synthesis. These addition products are usually solids, with well-defined melting points.

A significant characteristic of the diene synthesis consists in the fact that the two reaction components combine without a catalyst, frequently even without a solvent. Room temperature is often sufficient; only occasionally higher temperatures must be used. The reactions usually proceed to completion vigorously.

Maleic anhydride addition products intended for the purpose of identification have been reported for myrcene, ocimene, limonene, terpinolene, terpinene, phellandrene, carene, and caryophyllene, among others. In the case of phellandrene, under determined experimental conditions, maleic anhydride will react with α -phellandrene, but not with β -phellandrene, and thus serve as a useful reagent for distinguishing between the two isomers (see p. 43).

The reagent, maleic anhydride, is a white crystalline solid; melting at 53° – 54° ; soluble in acetone, chloroform, and ether; very slightly soluble in alcohol; and sparingly soluble in petroleum ether.

Goodway and West (see p. 43) recommended the preparation of the phellandrene addition product as follows:

Ten grams of α -phellandrene are refluxed with 5 g. of maleic anhydride in 20 cc. of ether for 30 min. The adduct is recrystallized from methyl alcohol.

Ethyl acetate has been recommended as a good solvent for the terpinolene adduct (p. 31).

In many instances the addition product resulting from diene synthesis may be converted into more than one compound useful for the identification of a particular substance. Thus, the adduct of maleic anhydride may be converted into the corresponding dicarboxylic acid or into a salt of this acid. For example, the barium salt of such an acid has been mentioned in connection with the isolation of α -terpinene. This acid salt may be decomposed by heating and the α -terpinene recovered (see p. 35).

The use of the diene synthesis for the preparation of derivatives of compounds occurring in essential oils is comparatively recent and offers good possibilities for further application to substances not yet investigated.

7. Addition of Sulfuric Acid (Sulfonation).—The addition of sulfuric acid to hydrocarbons often results in the introduction of the sulfonic group, $-\text{SO}_3\text{H}$.

Sulfonic acids are not to be confused with the esters of sulfuric acid (for example, alkyl sulfuric acid, $\text{RO}\cdot\text{SO}_2\text{OH}$). In ethyl sulfuric acid, also called ethyl hydrogen sulfate or ethyl acid sulfate ($\text{C}_2\text{H}_5\text{O}\cdot\text{SO}_2\text{OH}$), the $-\text{SO}_3\text{H}$ group is linked to the oxygen and not to the carbon.

The preparation of sulfonic acids does not always proceed smoothly and appears to be limited to certain hydrocarbons.

Experimental conditions and the nature of the reaction compound will determine the number of $-\text{SO}_3\text{H}$ groups, which can be added to a substance. The possibility of the formation of isomeric mixtures and the difficulties connected with their separation should not be overlooked.

As sulfonation agents, concentrated sulfuric acid or fuming sulfuric acid are most frequently used; acid sulfates, sulfite and acid sulfites, chlorosulfonic acids, and N-pyridinium sulfonic acid may also occasionally be employed.

Certain sulfonic acids are comparatively easily obtained by the action of concentrated sulfuric acid. If the sulfonic acids can be prepared with relative ease and have well-defined melting points, they may be useful for the identification of hydrocarbons.

Many sulfonic acids are crystalline solids, often hygroscopic and easily soluble in water. They are strong acids, forming metallic salts, which usually crystallize well. Their alkali salts are readily soluble in water. This offers a possibility of separating the sulfonic acids, as alkaline salts, from other water insoluble substances; subsequent acidification will then regenerate the desired sulfonic acid.

It must be kept in mind that under the influence of strong acids, such as sulfuric acid, not all compounds form the desired sulfonic acid; they may instead be converted into other compounds, isomerized, or polymerized, etc.

Sulfonic acids as identification products have been reported in connection with myrcene and cymene, among others.

It is also possible to identify the prepared sulfonic acid further by the preparation of *sulfonamides* ($R \cdot SO_2 \cdot NH_2$) (see "*p*-Cymene," p. 17). Aryl sulfonamides, particularly, are sparingly soluble, crystallize well, and may be used to great advantage for the identification of sulfonic acids. For this purpose the sulfonic acid in question is first converted into the more stable *sulfonyl chloride* ($R \cdot SO_2 \cdot Cl$)—for example, by the action of phosphorpentachloride or phosphoroychloride on the aryl sulfonic acid—which on treatment with ammonia yields the desired aryl sulfonamide.

8. Addition of Picric Acid and Related Substances.—Many aromatic hydrocarbons, particularly members of the condensed ring system, may be readily identified by the addition compounds formed with trinitrobenzene; the picrates, formed with trinitrophenol (picric acid); the styphnates, formed with trinitroresorcinol (styphnic acid); and the trotylates, formed with trinitrotoluene.

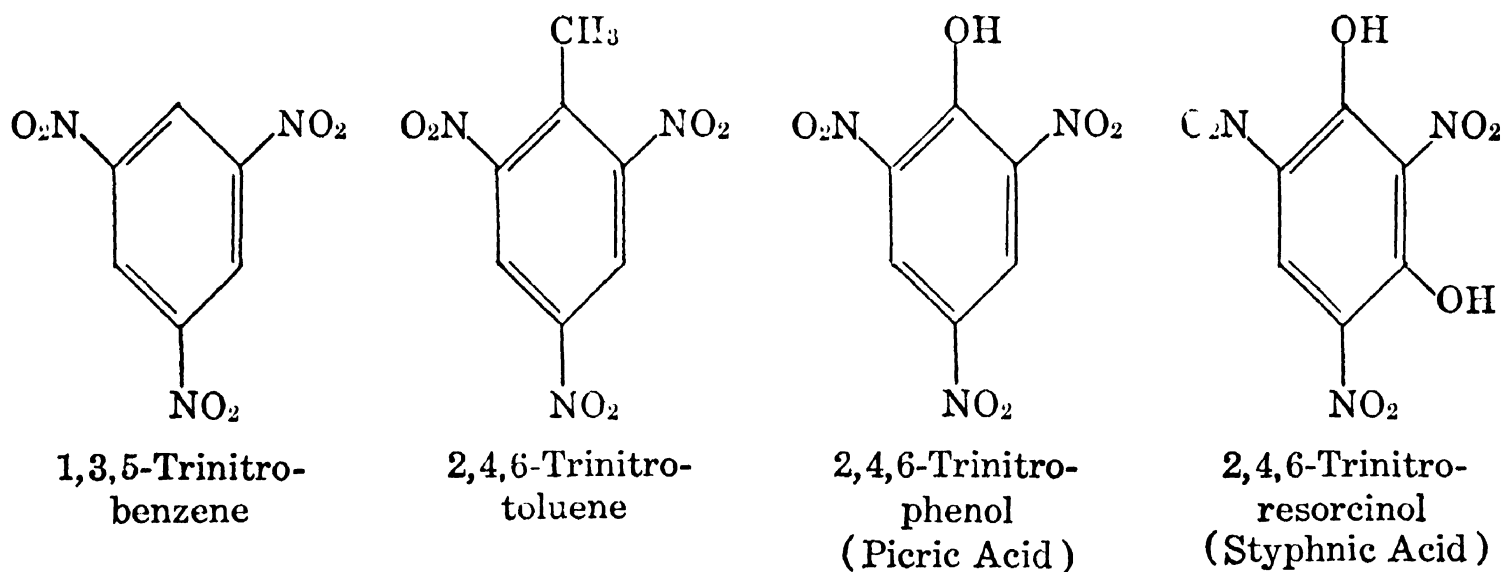

(a) *Trinitrobenzene*.—Trinitrobenzene is a pale yellow crystalline solid, melting at 121° , easily soluble in hot alcohol, but relatively insoluble in water.

It forms addition products with many aromatic hydrocarbons, phenols, certain amines, heterocyclic compounds, and aromatic ethers.

Generally speaking, the derivatives crystallize readily and possess a brilliant color.

The majority of addition compounds are equimolecular, but in several instances 2 mols of the reagent combine with only one of the substance (for example, stilbene, *o*-dianisidine, dibenzyl, etc.). In some cases 3 mols of the reagent may combine with two of the substance (for example, fluorene). Some compounds may combine with either 1 or 2 mols of trinitrobenzene.

The following general procedure is recommended for substances yielding derivatives stable in hot alcohol:

A mixture of equimolar quantities of substance and reagent is dissolved in hot alcohol, acetic acid, or benzene; upon cooling crystallization occurs. The crystals are separated and recrystallized and then dried in air.

(b) *Trinitrotoluene (Trotylates)*.—Trinitrotoluene is a pale yellow crystalline solid. Its melting point is 82°. Trinitrotoluene may also be used as a reagent to form addition products with hydrocarbons. These addition products, known as *trotylates*, can be prepared in the same way as the trinitrobenzene addition products. Both types have been reported for some compounds in the azulene series. Trinitrotoluene addition products, although they would appear to be as useful as those formed with trinitrobenzene, have not received as much attention in chemical literature.

(c) *Trinitrophenol (Picric Acid)*.—Picric acid is a bright yellow crystalline substance, melting at 122°, soluble in water (1 in 70 cold, 1 in 15 hot) and in cold alcohol (1 in 20).

It forms addition products with a large number of aromatic hydrocarbons, phenols, aromatic ethers, amines, alkaloids, and heterocyclic compounds. Such addition products are easily and rapidly prepared, and hence are especially to be recommended for identification purposes.

The picrate can be prepared by mixing hot solutions of the two components in a single solvent (usually alcohol, acetic acid, acetone, or water) and cooling until the crystalline derivative separates. Benzene, ether, or chloroform may sometimes be employed when the picrate is unstable to hydroxylic solvents. Some of the lower aromatic hydrocarbons may yield picrates only when the reagent is refluxed with the hydrocarbon. In certain cases, the addition products are very unstable and, if the hydrocarbon under examination is easily volatile, it may evaporate when a melting-point determination is attempted, leaving the pure picric acid m. 122°.

For the large majority of derivatives, 1 mol of the original substance will combine with 1 mol of picric acid. The addition product should be recrystallized from the original solvent until it has a constant melting point. This can generally be accomplished after one recrystallization.

Titration of the weakly acidic picrate solution may be of help in determining the molecular weight of the unknown component (assuming an equimolar composition).

For certain substances, purification by means of the picrate is possible. The picrate may be decomposed by treatment with warm dilute sodium hydroxide or ammonia to regenerate the original compound.

(d) *Trinitroresorcinol (Styphnic Acid)*.—Styphnic acid is a yellow, crystalline solid, melting at about 176°. It yields addition compounds with aromatic hydrocarbons (and alkaloids) in much the same manner as does picric acid. The compounds formed do not crystallize quite as readily as the picrates and are usually obtained in lesser yield. Nevertheless, they are useful derivatives, particularly since reliable reagents for hydrocarbons are few in number. This reagent will also form addition products with certain amines and heterocyclic compounds.

Almost all derivatives are equimolar. No stable derivatives are formed by the simple homologues of benzene.

For a general procedure the following may be useful:

A mixture of 1.23 g. of the reagent and 0.02 mol of the hydrocarbon is dissolved in 5–10 cc. of acetic acid by heat. Upon cooling, the addition compound crystallizes. The derivative is filtered off, washed first with acetic acid, then with alcohol, and finally dried in air.

After the melting point has been determined, it is best to recrystallize the derivative from acetic acid and to make another melting point determination.

With certain compounds it may be advisable to employ benzene as a solvent, since otherwise dissociation will occur. For naphthalene, azulenes, eudalene, and cadalene derivatives, alcohol may be employed.

Various other reagents have been found useful for the characterization of unsaturated hydrocarbons; these include:

- Naphtho- and anthraquinones ²⁹
- Nitro compounds and antimony trihalides ³⁰
- Antimony trichloride ^{31, 32, 33}
- Sulfur, hydrogen sulfide and mercaptans ³⁴
- Thiol compounds ³⁵

- ¹ *Liebigs Ann.* **368** (1909), 10, 13.
- ² *J. Org. Chem.* **7** (1942), 397.
- ³ *Liebigs Ann.* **362** (1908), 297. See also Henry and Paget, *J. Chem. Soc.* **123** (1923), 1878.
- ⁴ *Ind. Eng. Chem.* **19** (1927), 739.
- ⁵ *Liebigs Ann.* **264** (1891), 10.
- ⁶ The tables of oxidizing agents and products by J. Houben, "Die Methoden der organischen Chemie," 2d Ed., Vol. II (1931), 210, may prove of great value in this connection. Detailed procedures for specific oxidation are included in this work.
- ⁷ *Helv. Chim. Acta* **7** (1924), 92.
- ⁸ *J. prakt. Chem.* [2], **49** (1894), 1.
- ⁹ *Medd. Vetenskapsakad. Nobelinst.* **5** (1919), No. 8. *Ber. Schimmel & Co.* (1919), 130.
- ¹⁰ *Ibid.*
- ¹¹ *Ibid.*
- ¹² *Ber.* **53** (1920), 1821; **55** (1922), 2521.
- ¹³ *Nachr. Akad. Wiss. Göttingen Math. physik. Klasse* (1941), 59. *Chem. Abstracts* **37** (1943), 3074.
- ¹⁴ "Terpene und Campher," 2d Ed. (1914), 59.
- ¹⁵ *Ber.* **27** (1894), 448.
- ¹⁶ *Chem. Ztg.* **22** (1898), 827.
- ¹⁷ *J. Gen. Chem. (U.S.S.R.)* **7** (1937), 994. *Chem. Abstracts* **31** (1937), 5340.
- ¹⁸ *Australian Chem. Inst. J. and Proc.* **14** (1947), 376. *Chem. Abstracts* **42** (1948), 2246.
- ¹⁹ "The Terpenes," 2d Ed., Vol. I (1947), 162.
- ²⁰ *Helv. Chim. Acta* **4** (1921), 149.
- ²¹ *Ber. Schimmel & Co.*, April (1910), 165. See p. 57 of this work.
- ²² *Liebigs Ann.* **245** (1888), 258.
- ²³ *Ibid.* **356** (1907), 223.
- ²⁴ "The Terpenes," 2d Ed., Vol. I (1947), 198, 207.
- ²⁵ "Die Terpene," from "Handbuch der biologischen Arbeitsmethoden," by E. Abderhalden. Urban and Schwarzenberg, Berlin and Vienna (1929), 965.
- ²⁶ *Liebigs Ann.* **287** (1895), 384; **313** (1900), 346; **350** (1906), 176; **356** (1907), 223.
- ²⁷ *Ibid.* **241** (1887), 321; **252** (1889), 118; **270** (1892), 181.
- ²⁸ *Angew. Chemie* **42** (1929), 911.
- ²⁹ Diels and Alder, *Ber.* **62** (1929), 2337. *Chem. Abstracts* **24** (1930), 847.
- ³⁰ Shinomiya, *Bull. Chem. Soc. Japan* **15** (1940), 259. *British Chem. Abstracts* (1940), A, I, 412.
- ³¹ Sabetay, *Compt. rend.* **197** (1933), 557.
- ³² Levine and Richman, *Biochem. J.* **27** (1933), 2051. *Chem. Abstracts* **28** (1934), 3392.
- ³³ Delaby, Sabetay, and Janot, *Compt. rend.* **198** (1934), 276. *Chem. Abstracts* **28** (1934), 2321.
- ³⁴ Jones and Reid, *J. Am. Chem. Soc.* **60** (1938), 2452.
- ³⁵ Ipatieff, Pines and Friedman, *ibid.*, 2731. Cf. Ipatieff and Friedman, *ibid.* **61** (1939), 71, 684.

II. ALCOHOLS

The derivatives most frequently employed for the identification of alcohols are those which characterize the functional hydroxyl group —OH (phenols also contain the hydroxyl group and may be considered a special type of alcohol).

Many organic as well as inorganic esters are prepared primarily for the isolation of the alcohols; if the esters are crystalline and have well-defined melting points they may also serve as derivatives for identification purposes. Among the esters most frequently employed are the benzoates, phthalates, and borates.

For identification purposes, the urethanes are of great importance, the α -naphthylurethanes and *p*-nitrophenylurethanes being reported most frequently in literature.

Some alcohols can also be identified by many of the procedures already described for the identification of hydrocarbons: oxidation, hydrogenation, formation of reaction products with compounds containing nitrogen (such as nitrosyl chloride), formation of reaction products with halogens, with hydrogen halides, etc. However, only those reaction products peculiar to the —OH group will be discussed here, and in the following order:

1. Dehydration Products
2. Calcium Chloride Addition Products
3. Esters:
 - (a) Borates
 - (b) Phthalates (Nitrophthalate)
 - (c) Benzoates (*p*-Nitrobenzoate, 3,5-Dinitrobenzoate)
 - (d) Sulfonates and Sulfates
4. Urethanes:
Phenyl-, α -naphthyl-, *p*-nitrophenyl-, 2,4-dinitrophenylurethane, allophanate (= carbamylurethane)
5. Xanthates (= Xanthogenates)

1. Dehydration Products

In this section dehydration means the elimination of the elements of water from an organic compound. Most tertiary alcohols are unstable and split off water when reacted upon by the reagents generally employed in the preparation of alcohol derivatives. Dehydration products (usually hydrocarbons) will result, which may be useful for the identification of an alcohol, if the dehydration product can readily be identified. For an excellent example of this technique the reader is referred to the work of Ipatieff and Pines.¹

Dehydration methods are generally based upon catalytic decomposition of tertiary alcohols with gentle heating. Catalysts which induce dehydration include: most acids (sulfuric, formic, acetic, phthalic, etc.) and certain acid anhydrides (acetic, phthalic, phosphorous pentoxide, etc.), iodine, zinc chloride, magnesium chloride, and potassium bisulfate.

Certain alcohols will dehydrate almost quantitatively under special experimental conditions, a fact useful in their quantitative determination. (See Vol. I of this work, p. 277. A similar procedure may generally prove satisfactory for qualitative tests.) Dehydration as a means of identification is employed chiefly with tertiary alcohols,

such as linaloöl, terpineol, terpin hydrate, and cedrol, which dehydrate readily. Certain secondary alcohols, however, may also dehydrate, for example, isoborneol and isopulegol. Among the primary alcohols geraniol is a notable exception in that it dehydrates readily with zinc chloride and similar catalysts.

2. Calcium Chloride Addition Products

Many primary alcohols—among them ethyl alcohol, butyl alcohol, geraniol, benzyl alcohol, and cinnamic alcohol—form complex, crystalline salts when shaken with powdered anhydrous calcium chloride in absolute ether or in benzene, or sometimes in the absence of a solvent.

Calcium chloride addition products are employed largely for purposes of isolation and purification. The original alcohol is easily regenerated by the addition of water to the separated calcium chloride complex.

The geraniol addition product is the most important of those listed above, since it affords a means of separating this alcohol from similar primary alcohols (such as nerol and citronellol). A procedure for the preparation of calcium chloride addition products will be found in the monograph on "Geraniol" (p. 171). It should be remembered that the separation of geraniol by this method is not quantitative; furthermore the sample under examination should contain at least 25 per cent of geraniol.

3. Esters

In the present section only those esters which are most frequently used in essential oil chemistry will be considered.

Esters of succinic, oxalic, and malonic acids (and others) are often employed to identify certain alcohols, since they constitute characteristic derivatives.

In the preparation of esters of organic acids, acids as such are only seldom used, their anhydrides or chlorides being better suited to the purpose.

Primary and secondary alcohols react with acyl chlorides to form esters. Tertiary alcohols, however, frequently do not react in this way; instead they may dehydrate to form hydrocarbons, halogen derivatives of hydrocarbons, or complex mixtures of the ester and dehydration products.

As a general rule primary, secondary, and tertiary alcohols differ greatly in respect to the speed with which they react to form esters. The extent of the esterification accomplished in a given time, under standard conditions, may therefore often be of considerable value in differentiating between these various groups of alcohols. Procedures based on the rates of esterification have been used for many years in the essential oil field.

With acid anhydrides, primary alcohols react more quickly than secondary alcohols, and the latter react more quickly than tertiary alcohols.

On the other hand, with halogen acids, primary alcohols react only slowly upon refluxing—for example, with 48 per cent hydrogen bromide—whereas secondary alcohols react fairly rapidly with the same reagent. Certain tertiary alcohols, however, react very quickly with halogen acids (hydrogen bromide, for example) to give a good yield of alkyl halides.²

In working with certain alcohols it may prove desirable to prepare special esters, which, however, cannot easily be formed. In such cases it may be necessary to resort to a method seldom employed for identification purposes—the so-called ester exchange, illustrated in the following equation:

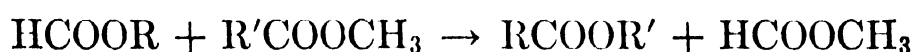

The alcohol may be first esterified, with an organic acid of low molecular weight (such as acetic or formic acid) at room temperature, so that dehydration of the alcohol does not take place. After the ester (formic ester, for example) is separated, it is allowed to react with an equimolar amount of methyl ester of the carboxylic acid, which will furnish the acid component of the desired ester. Verley ³ has reported on this exchange of reactive groupings which may be taken advantage of for sensitive primary, secondary, and tertiary alcohols. Difficulties are sometimes encountered, especially with tertiary terpene alcohols.

Certain esters—borates, acid phthalates, and benzoates, for example—are formed not only with pure alcohols, but in fractions rich in alcohols. They are, therefore, especially useful for the isolation and purification (as well as identification) of alcohols. Such esters are generally high boiling, and lower boiling impurities in mixtures containing them can easily be distilled off *in vacuo*. Esters thus isolated may be purified and subsequently hydrolyzed to yield the pure alcohol.

(a) **Borates (Boric Esters).**—*Primary and secondary* alcohols can readily be converted into the esters of boric acid. This reaction offers the possibility of separating these alcohols from essential oils or other mixtures.

Since tertiary alcohols do not react with boric acid to any appreciable extent under the standard experimental conditions, and since primary alcohols esterify more rapidly than secondary alcohols, the preparation of borates offers a further possibility of separating the three groups of alcohols. The borates may frequently be purified by recrystallization before regeneration of the alcohol.

One of the chief advantages in the use of borates for the separation of alcohols lies in the fact that boric acid or boric anhydride is *weakly* acidic and, in the presence of sensitive substances, causes comparatively little molecular rearrangement or decomposition.

The procedure has been employed successfully in industry; the patent literature ⁴ describes a number of methods.

If the borates are solids and can be further purified by recrystallization, they may serve as useful derivatives in the identification of alcohols. In many cases the alcohol may be obtained in a pure state by hydrolysis of the recrystallized borate.

For the formation of borates of those alcohols which are subject to dehydration, Kaufmann ⁵ suggested carrying out alcoholysis so that an exchange of the alcohol radical is effected. To obtain the desired crystalline borate Kaufmann treated the alcohol with a low boiling borate (ethyl or butyl) thus effecting an alcohol interchange.

Schmidt ⁶ suggested the following procedure:

The amount of boric anhydride, calculated to be necessary for the formation of the triester, is added to the alcohol, and the mixture is heated to about 80°–100° in a suitable distilling flask. The water formed by the reaction is distilled off, under slightly reduced pressure (this water can be measured to estimate the completion of the reaction). The borate is finally recrystallized from a suitable solvent.

A slightly different method has been found to be practical for the preparation of certain borates. The reaction should be carried out by refluxing the reaction mixture in a water insoluble solvent, such as benzene, toluene, or xylene. The solvent is chosen for its boiling point, which should be within the range of the temperature at which the borate forms most favorably. The water formed during the reaction can be carried over with the solvent into a water trap. It often proves effective to add acetic anhydride in catalytic amounts to the reaction mixture.

When mixed anhydride, in a calculated amount, is employed to form the borate, the same procedure as that outlined above may be followed. The mixed anhydride

is prepared by combining 1 part by weight of boric acid with 5 parts by weight of acetic anhydride:

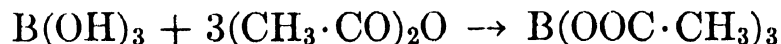

Zeitschel⁷ reports that arsenous acid [As(OH)_3], arsenous anhydride (As_2O_3), or the mixed anhydride with acetic acid [$\text{As(OOC}\cdot\text{CH}_3)_3$], may be used in the same manner as the boric acid reagents discussed above. Antimonous acid [Sb(OH)_3] or phosphorous acid [P(OH)_3] and their anhydrides and mixed anhydrides may also be employed in the same way. For all mixed anhydrides the acetic anhydride may be replaced by other organic anhydrides, such as propionic, butyric, valeric, benzoic, or phthalic anhydride. However, with the use of arsenous, antimonous, and phosphorous acid reagents, the reaction proceeds at somewhat higher temperatures. In this respect boric acid offers an advantage.

(b) Phthalates (Phthalic Acid Esters).—Phthalic acid esters are very often prepared not only for the identification of certain alcohols, but for their isolation and purification. Phthalic acid esters are prepared by treating alcohols (or fractions rich in alcohols) with phthalic anhydride, by which procedure the monoester (i.e., the *acid ester*) is formed.

In many, but not all cases, the preparation of phthalic acid esters has been used frequently for the separation of primary, secondary, and tertiary alcohols occurring in essential oils. Primary alcohols form acid phthalates quantitatively, even at steam-bath temperatures in dilute benzene solutions, and may be separated, as sodium salts of the phthalic acid esters, from the secondary and tertiary alcohols. Secondary alcohols react less readily, and it is usually necessary to heat the mixture of anhydride and alcohol to a temperature of 120° – 130° without solvents. Tertiary alcohols, under such conditions, are not reactive.

Phthalic acid esters have been prepared for a great number of aliphatic, aromatic, and terpene alcohols.

It is possible to prepare the silver salt from the acid phthalate; such salts may be used for identification purposes (for example, of 3-hexenol, bupleurol, geraniol, citronellol).

Pickard and Kenyon⁸ prepared the monoester of a number of secondary alcohols, and converted the pure acid phthalates into their alkaloidal salts (for example, strychnine, cinchonidine and brucine salts)—a method which proved suitable for the identification of certain alcohols (2-heptenol, 3-octanol, 2-hendecanol, thujyl alcohol, santalol, etc.).

For the purpose of separating primary and secondary alcohols from essential oils, Elze⁹ recommended the method described below.

The reagent phthalic anhydride is a white crystalline solid, melting at 129° – 131° . It is only slightly soluble in cold water; more soluble in hot water, forming phthalic acid; soluble in alcohol; but less soluble in ether.

Equal parts by weight of the alcohol, of benzene, and of phthalic anhydride are refluxed for $1\frac{1}{2}$ hr. After cooling, the excess phthalic acid is precipitated with petroleum ether and separated; the solvent is then distilled off and the residue treated with sodium or potassium carbonate solution. Two layers will form, of which the lower one is discarded. The upper layer is then dissolved in large amounts of water. This solution is extracted with ether to separate unreacted impurities that have not combined with phthalic anhydride. The aqueous solution is then acidified with 20% sulfuric acid and the phthalic acid monoester precipitated with sodium chloride ("salted out"). The ester may now be extracted with ether, and after the ether is evaporated the acid phthalate may be recrystallized.

Saponification of the phthalic acid ester with alkali (for example, alcoholic potassium hydroxide) will regenerate the pure alcohol, which can be separated by adding

water and extracting with ether. The ether layer should be washed * until neutral, preferably with tartaric acid solution and then with water. After the ether is evaporated the primary alcohol can be distilled for purification purposes.

Secondary alcohols should be heated for 1½ hr. with phthalic anhydride without a solvent on an oil bath at 125°, then separated as above.

Goggans and Copenhaver¹⁰ prepared a series of monoalkyl phthalates from normal aliphatic alcohols and suggested heating the anhydride with the alcohol for 30 min. to 2 hr. at 105°–110°. The amount of anhydride and the time of heating were increased as the molecular weight of the alcohol increased.

The reaction mass of the lower boiling alcohols, after heating, must be treated differently from the reaction mass of the higher boiling alcohols. The variation of procedure is based upon the difference in solubility between low boiling alcohol sodium phthalates and high boiling alcohol sodium phthalates, in aqueous solution.

For the lower boiling alcohols the following procedure has been developed by Goggans and Copenhaver:¹¹

The reaction mass is treated with benzene, the excess anhydride is filtered off and the mixture neutralized with dilute sodium carbonate, leaving the solution slightly acid. The aqueous layer is extracted with benzene to remove unreacted alcohol and possible diesters. The esters are precipitated as crystalline solids from the water solution by dilute hydrochloric acid, and recrystallized from a mixture of petroleum ether and 10% benzene.

For the higher boiling alcohols the following procedure has been suggested by Goggans and Copenhaver:¹²

The reaction mass is treated with ether and filtered to remove excess anhydride. After evaporation of the ether, the residue is warmed with water to 60°–65° for 45 min. to hydrolyze any remaining anhydride. The dried residue is dissolved in a small amount of chloroform and filtered to remove any phthalic acid; the chloroform is evaporated *in vacuo*, and the ester recrystallized from petroleum ether.

The preparation of phthalic acid esters for identification of certain tertiary alcohols has been reported, but the yields of reaction products are very small.

It should be pointed out here that phthalic anhydride will react also with compounds other than alcohols—viz., amines, phenols, and hydrocarbons.

The melting points of phthalic acid esters are sometimes too low to serve conveniently as means of identifying alcohols. For this reason *3-nitrophthalic acid esters*, generally possessing higher melting points, are often preferable.

The reagent, 3-nitrophthalic anhydride, is a yellow crystalline solid, melting at 163°–164°. It readily reacts with alcohols (especially aliphatic), forming monoesters in the same manner as phthalic anhydride.

According to Nicolet and Sachs¹³ the preparation of these esters may be carried out as follows:

A quantity of the anhydride is treated with half its weight of alcohol and heated on a water bath for 10 min. The product is then dissolved in hot water, allowed to crystallize, filtered, dried, and recrystallized.

The phthalic monoesters possess a further advantage over other alcohol derivatives, viz., being *acids* they may be titrated with standard alkali to determine the molecular weight equivalent of the alcohol. The determination of molecular weight equivalent may be of special advantage where the melting points of the alcohol acid phthalates lie too closely together to be of use in identification.

* For water soluble esters, see the procedure of Goggans and Copenhaver (see below).

One disadvantage connected with these derivatives should be noted, however: in the case of certain 3-nitrophthalates, two isomeric esters—whose separation may be difficult—can be formed.

The use of other substituted phthalic anhydrides has been suggested. Fessler and Shriner,¹⁴ for example, reported on derivatives of tertiary alcohols obtained by reacting tertiary alkoxy magnesium bromides with tetrachlorophthalic anhydride. The solid esters resulting from this reaction may be characterized by their neutral equivalents and their decomposition points.

(c) Benzoates (Benzoic Esters).—Esters of benzoic acid are often prepared for the separation and purification of an alcohol; they are occasionally used also for identification purposes.

In the preparation of benzoates (*benzoylation*) benzoic anhydride or benzoyl chloride may be employed to form esters of benzoic acid, which are usually high boiling.

Of the two reagents, benzoic anhydride reacts more slowly. If used in the preparation of alcohol derivatives, application of heat for several hours in the presence of sodium benzoate may be necessary. For this reason, benzoyl chloride is to be preferred as a reagent.

The reaction of organic compounds with benzoyl chloride has been studied by Schotten,¹⁵ and by Baumann;¹⁶ the method of benzoylation based on their work is still very widely used.

Benzoyl chloride possesses an advantage over certain other acyl chlorides, which may serve for the preparation of derivatives, in that it decomposes only very slowly in cold water. The fact that the —OH group of the alcohol reacts much more rapidly with this acyl chloride than does the —OH group of the water permits preparation of esters even in aqueous solution. The benzoyl esters formed are insoluble in water.

Esterification with benzoyl chloride may be effected under various experimental conditions. Usually it is carried out in an alkaline medium, for example, in the presence of sodium carbonate, pyridine, quinoline, dimethyl aniline. In certain instances derivatives may be prepared more effectively by refluxing the alcohol with benzoyl chloride itself.

Generally only primary and secondary alcohols react with benzoyl chloride (or substituted benzoyl chlorides) to form benzoates. Tertiary alcohols are usually converted in large part to the corresponding chlorides. However, it may be possible to prepare esters from the *tertiary* alcohols (as well as from primary and secondary alcohols) by the reaction of the appropriate benzoyl chloride with the alcohol *in the presence of absolute pyridine*.

It is possible to prepare other benzoates, such as *p*-nitrobenzoates or 3,5-dinitrobenzoates. These latter are often preferable to other benzoates because of the readiness with which they crystallize.

Benzoyl chloride is an almost colorless liquid, which fumes in moist air.

p-Nitrobenzoyl chloride is a pale yellow crystalline powder with a melting point of 72°–73°. It slowly hydrolyzes in moist air to *p*-nitrobenzoic acid; it is readily soluble in benzene and carbon tetrachloride and somewhat less soluble in petroleum ether.

3,5-Dinitrobenzoyl chloride is a white crystalline solid, melting at 68°–69°, which hydrolyzes in moist air to dinitrobenzoic acid and hydrogen chloride; it is soluble in nonpolar solvents without decomposition.

Phenols and certain amines also react with benzoyl chloride.

The preparation of *benzoates* or *p*-nitrobenzoates may be carried out as follows:

Dissolve the alcohol (or phenol) in a small amount of pyridine, and add an equivalent, or a slightly larger quantity, of benzoyl chloride or *p*-nitrobenzoyl chloride.

After refluxing for a short time, cool the solution, and add water. Allow the solid ester to settle, then filter off and wash, first with a little cold dilute sodium hydroxide or sodium carbonate and then with water. Recrystallize the ester from a suitable solvent, such as petroleum ether or ethyl alcohol.

For the preparation of alkyl *p*-nitrobenzoates, compare also Armstrong and Copenhaver.¹⁷

Dinitrobenzoates are readily formed and, as alcohol derivatives, are often recommended even though their melting points are occasionally somewhat low. These esters form addition products—upon reaction with α -naphthylamine—possessing well-defined melting points, usually higher than those of the original esters, and therefore are of additional value in characterizing an alcohol.

A slightly different method for the preparation of dinitrobenzoates has been recommended by Hopkin and Williams:¹⁸

Dissolve 1 g. of dinitrobenzoyl chloride in 10 cc. of benzene, and add to this solution the equivalent amount of alcohol to be tested. Then add a few cubic centimeters of anhydrous pyridine. Boil the mixture gently for a few minutes and allow it to cool. (In the case of tertiary alcohols it is often necessary to reflux for 30 min.) Add ether in excess to the cooled solution, and wash the ethereal solution first with dilute acid, then with dilute alkali, and finally wash neutral with water. Evaporate the dried ethereal solution to dryness, and recrystallize the solid from petroleum ether or benzene or a similar suitable solvent.

For the preparation of the α -naphthylamine addition product add an excess of the α -naphthylamine dissolved in ether to the ethereal solution of the dinitrobenzoate, and recrystallize the resulting solid, for example, from ethyl alcohol.

All benzoates (*p*-nitro- or dinitro-) may be saponified with alkali, and in many cases the original alcohol can be separated in the pure state.

(d) **Sulfonates and Sulfates.**—In special cases it may be advisable to prepare certain sulfonates or sulfates for the identification of an alcohol.

The *p*-toluene sulfonates have been prepared from certain alcohols—for example, benzyl alcohol (see p. 290) with *p*-toluene sulfonyl chloride as reagent. The *p*-toluene sulfonates, however, are more frequently employed for the identification of phenols and, therefore, will be discussed under “Phenols” (see p. 824).

Bair and Suter¹⁹ have converted a number of alcohols into their corresponding *alkyl hydrogen sulfates* and have suggested further characterizing these sulfates by their *S*-benzylthiuronium derivatives. *S*-benzylthiuronium chloride forms derivatives, which are of value for the identification of many acids and acid salts (especially sulfonic acids and sulfates).

Although these derivatives are usually employed for the characterization of certain acids (see p. 839), they will be discussed here, since they have been mentioned frequently in the monographs on the individual alcohols.

The reaction involved has been represented by Bair and Suter as follows:

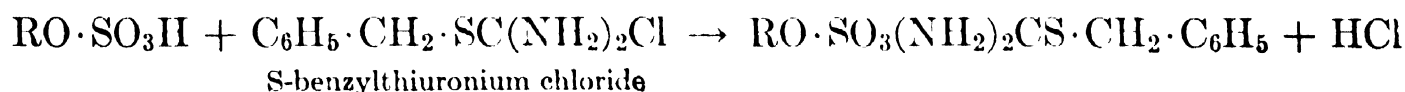
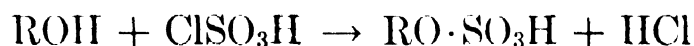

(The reagent may be prepared in nearly quantitative yield by the reaction of benzoyl chloride with thiourea.)

Benzylisothiurea hydrochloride,

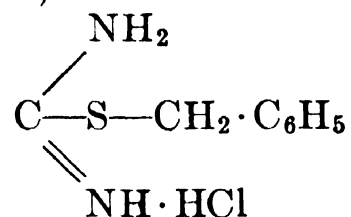

or S-benzylthiuronium chloride is a white crystalline compound exhibiting dimorphism; the two forms, melting at 150°–151° and at 176°–177°, both yield the same derivatives.

The alcohol under investigation is easily converted into the alkyl hydrogen sulfate by the action of chlorosulfonic acid upon the alcohol in dioxane solution. If hydrogen chloride is not immediately evolved, the mixture should be warmed with shaking for several minutes. Then water and a saturated aqueous solution of S-benzylthiuronium chloride (or a 15 per cent alcoholic solution) are added to the mixture. If crystals do not form after a few minutes the solution should be cooled in an ice bath. The solid derivative is then separated and recrystallized from dilute alcohol.

4. Urethanes

Alcohols and phenols react with certain N-substituted isocyanates to form esters of carbamic acid, also referred to as *carbamates*, or more commonly as urethanes. Among the many derivatives of primary and secondary alcohols the carbamates or urethanes constitute the derivatives most often prepared; they can also be prepared for many tertiary alcohols.

The urethanes most frequently reported in literature are the α -naphthyl-, *p*-nitrophenyl-, and phenylurethanes.



Traces of moisture interfere with the above reaction. The reaction is also sensitive to ammonia and amines. The presence of water, for example, as an impurity in the alcohol, often makes it difficult to obtain urethanes. Water hydrolyzes the isocyanates, yielding arylamines, which combine with the excess reagent to produce di-substituted ureas:

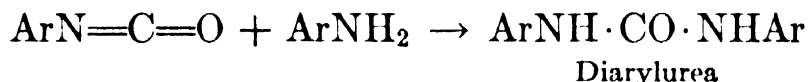

The ureas have a higher melting point and are less soluble than the corresponding urethanes and, present even in small amounts, may make the isolation and purification of the urethanes a matter of considerable difficulty. For this reason, the preparation of urethanes is most useful for those alcohols which are insoluble in water and, hence, easily obtained in anhydrous condition.

Urethanes can be prepared from certain tertiary alcohols only with difficulty, since the reaction between isocyanates and tertiary alcohols generally causes dehydration with the result that a hydrocarbon is formed, and the liberated water combines with the isocyanate to form diarylurea. These by-products often interfere seriously with the separation of the formed urethane. Traces of water interfere less with the reaction when α -naphthylisocyanate is used than when phenylisocyanate is employed. Primary alcohols react with α -naphthylurethane without heating. Secondary alcohols generally require heating. In this case, however, if traces of water are present in the alcohol,

too much di- α -naphthylurea may form. Urethanes of tertiary alcohol cannot be obtained readily—if at all.

For those phenylurethanes and α -naphthylurethanes which can be prepared only with difficulty, Schimmel & Co.,²⁰ for example, suggested that the reaction mixture be allowed to stand for several days so that the reaction might go to completion. In some instances, even this may not be sufficient, and it may be necessary to apply heat after the mixture has been allowed to stand for some time; for example, a mixture of linaloöl and α -naphthylisocyanate had to be heated even after standing for 5 to 6 days.

The preparation of α -naphthylurethanes is similar to that of the phenylurethanes. α -Naphthylisocyanate (α -naphthylcarbimide) is a colorless liquid, boiling at 153° at 18 mm. The fact that α -naphthylisocyanate is less irritant and is more stable toward water than phenylisocyanate makes the use of α -naphthylisocyanate more desirable as a reagent.

Phenylisocyanate (phenylcarbimide) is a colorless liquid boiling at 160°–163°. Its vapor, even at normal temperatures, is irritant and lachrymatory. The liquid reacts very readily with water and must be protected from atmospheric moisture. Even with protection, however, it may contain crystals of diphenylurea (carbanilide), the product of reaction with water. When this substance forms as impurity, it can be separated in the ordinary course of preparing phenylisocyanate derivatives (see below).

The preparation of α -naphthyl- or phenylurethanes may be carried out as follows:

The dry alcohol is mixed in a dry test tube with slightly less than an equimolar quantity of the reagent. With many alcohols the reaction is spontaneous, and the mixture becomes warm; but in all cases the reaction should be completed by heating gently on a steam bath for a few minutes. On cooling, the derivative solidifies and may be recrystallized from petroleum ether or carbon tetrachloride. Any traces of diphenylurea present may easily be removed by filtration from petroleum ether.

The phenylurethanes are also known as carbanilates (and phenylcarbamates). It is recommended that reactions with α -naphthylisocyanate and certain alcohols, such as cinnamyl alcohol, menthol, and borneol be carried out in boiling petroleum ether (100°–120°).²¹

α -Naphthylurethanes generally crystallize well from petroleum ether.

p-Nitrophenylisocyanate (*p*-nitrophenylcarbimide) is a yellow crystalline substance melting at 56°–57°; it is soluble in carbon tetrachloride, benzene, and other nonpolar solvents. The reagent reacts readily with atmospheric moisture, yielding a very insoluble di-*p*-nitrophenylurea. For this reason it must be stored in well-closed containers. It has none of the lachrymatory properties of phenylisocyanate.

For the preparation of *p*-nitrophenylurethanes it is recommended that the isocyanate be mixed with an excess of the alcohol in benzene, carbon tetrachloride, or petroleum ether. The reaction will usually be spontaneous. After slight heating, the warm solution is filtered and allowed to crystallize. The urethane may be recrystallized from these solvents or from 50 per cent ethyl alcohol.

For the preparation of *p*-nitrophenylurethane, compare also Shriner and Cox,²² and Home and Shriner.²³

A number of N-substituted isocyanates have been employed as reagents for alcohols by different authors: *o*- and *m*-nitrophenylisocyanate and 3,5-dinitrophenylisocyanate (Hoeke²⁴); *p*-methoxyphenylisocyanate (anisylisocyanate) and 3,4-dimethoxyphenylisocyanate (Brunner and Wöhrle²⁵); 4-iodo-diphenyl-4'-isocyanate (Kawai and Tamura²⁶); *p*-xenyliisocyanate ($C_6H_5 \cdot C_6H_4 \cdot N=C=O$) (van Gelderen²⁷); *p*-(triphenylmethyl)phenyl and 2-fluorenyliisocyanates (Witten and Reid²⁸).

The reagent diphenylcarbonyl chloride is used generally with phenols, but occasionally also with alcohols, to form *diphenylurethanes*. (These derivatives will be discussed under "Phenols," p. 824.)

Urethanes are also produced by treating the alcohol with acid azides:

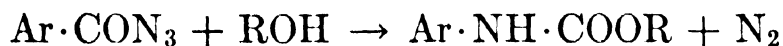

For example, *p*-nitrophenylurethane may be prepared by treating the alcohol with *p*-nitrobenzazide. *p*-Nitrobenzazide $\text{NO}_2\cdot\text{C}_6\text{H}_4\cdot\text{CON}_3$ is a solid melting at 69° .

The urethane is prepared by mixing *p*-nitrobenzazide with the alcohol in dry petroleum ether and refluxing it in dry petroleum ether for 2 hr. (see Shriner and Fuson²⁹). The solution is then allowed to cool, and the solid urethane is separated and recrystallized from petroleum ether, benzene, or ethyl acetate. A similar method may be employed for the preparation of urethanes from other substituted benzazides.

Sah and Kak-Yuen Tao³⁰ used *p*-bromobenzazide as a reagent. Chang, C. C. Wang and C. H. Wang³¹ suggested other azides, i.e., *o*-nitro-, *m*-nitro-, *o*-chloro-, *m*-chloro-, *p*-chloro-, *o*-bromo-, *m*-bromo-, and *p*-bromobenzoyl azides, as reagents.

The preparation of the *2,4*-dinitrophenylurethanes of many alcohols has been reported by van Ginkel.³² For this purpose—instead of the isocyanate usually employed for the preparation of urethanes—he used *N*-(*2,4*-dinitrophenyl)-*N'*-methyl-nitrourea. This reagent, when reacted with an alcohol, forms the *2,4*-dinitrophenylurethane:

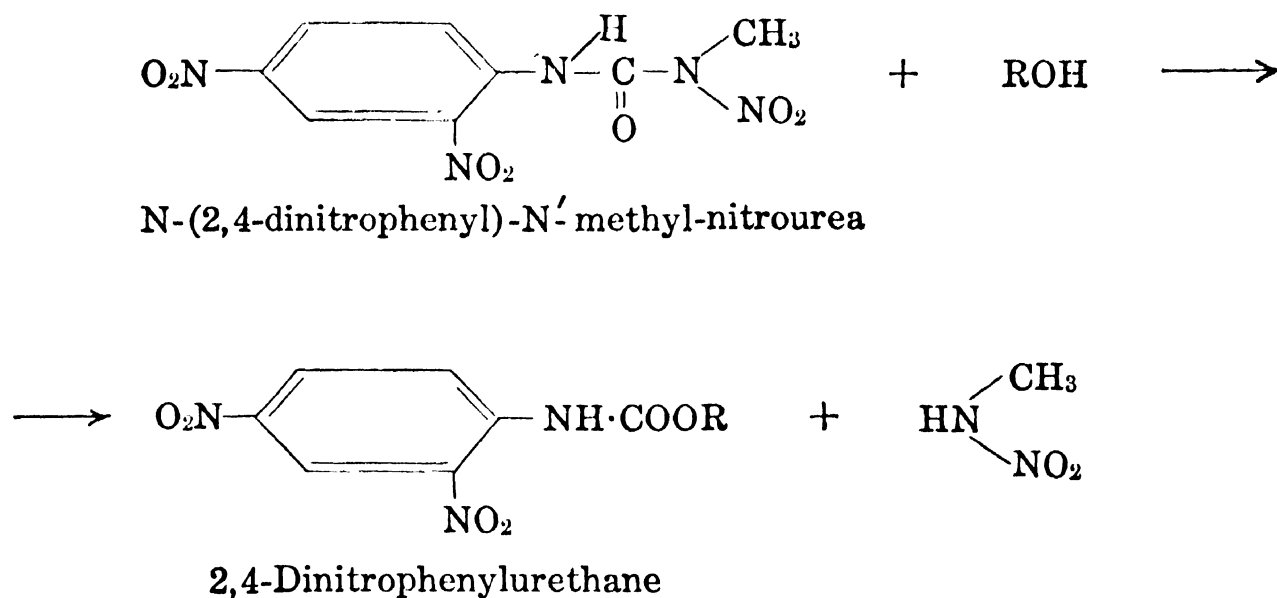

In this reaction the group $\text{---N} \begin{array}{l} \text{CH}_3 \\ \text{NO}_2 \end{array}$ splits off to form methylnitramine. The *N*-(*2,4*-dinitrophenyl)-*N'*-methyl-nitrourea upon boiling with water forms dinitroaniline and methylnitramine.

N-(*2,4*-dinitrophenyl)-*N'*-methyl-nitrourea is a yellow-white crystalline solid which decomposes at a temperature from 76° – 98° , depending on the rate of heating. It is slightly soluble in ether, petroleum ether, and more soluble in chloroform and carbon tetrachloride. The reagent is odorless and does not fume in air like the phenylisocyanates, nor is it hygroscopic. It is, however, sensitive to light and high temperature.

For the preparation of *N*-(*2,4*-dinitrophenyl)-*N'*-methyl-nitrourea, the reader is referred to the above cited work of van Ginkel.

N-(*2,4*-dinitrophenyl)-*N'*-methyl-nitrourea yields *2,4*-dinitrophenylurethanes with primary, secondary, and many tertiary alcohols, the yields ranging from 53 to 85 per cent.

This urethane is prepared as follows:

The alcohol in some excess is boiled gently with N-(2,4-dinitrophenyl)-N'-methyl-nitrourea in benzene solution for several hours. Upon cooling, the urethane usually crystallizes partially. Some of the benzene is evaporated and the urethane precipitated by the addition of petroleum ether. The 2,4-dinitrophenylurethane is recrystallized from petroleum ether or ethyl alcohol. Methylnitramine and 2,4-dinitroaniline may form as by-products during the reaction. Methylnitramine dissolves easily in water, ether, alcohol, and many other solvents, but not in petroleum ethers. Upon boiling with petroleum ether it can be separated by filtration. The formation of dinitroaniline will depend on the amount of water present in the alcohol; but the dinitroaniline will also be separated upon filtration after boiling with petroleum ether. Hence, if only traces of water are present it is not necessary to dry the alcohol or solvent (for example, benzene) before preparing the derivative. Another by-product, which may be formed after boiling the reagent in benzene for a long time, is 2,4-dinitrophenyl methylurethane (m. 125°–126°):

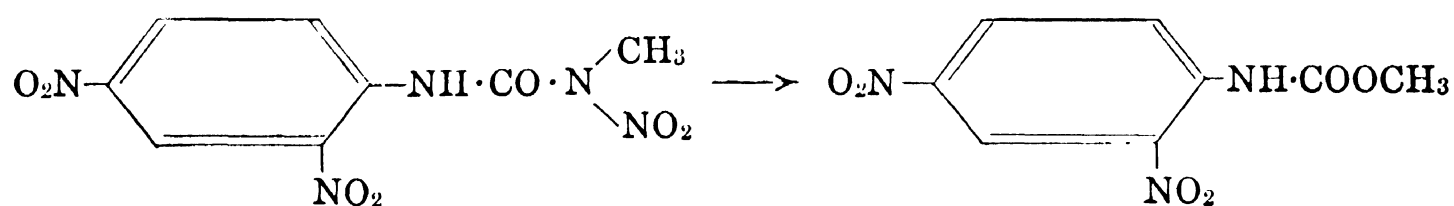

Because of the possible formation of this by-product the reagent cannot be used to prove the presence of methyl alcohol. Generally, however, the 2,4-dinitrourethanes are easily prepared by the method described above (van Ginkel).

Allophanates are carbamylcarbammates or carbamylurethanes having the following formula:

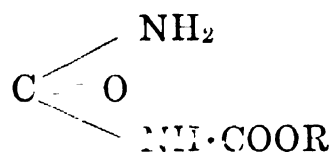

in which R represents the alcohol radical.

Béhal³³ has prepared these derivatives from a number of alcohols occurring in essential oils. Primary, secondary, and some tertiary alcohols (and phenols) form allophanates.

Allophanates can also be used for purposes of isolation and purification. After the allophanate has been separated from other substances and purified by crystallization, it may be saponified, which results usually in the formation of the original alcohol, carbon dioxide and urea. The allophanates of certain tertiary alcohols hydrolyze upon boiling with water alone. To obtain allophanates a current of cyanic acid gas (HO-CN), formed by decomposing cyanuric acid, is passed into the cooled alcohol (or a solution rich in alcohol). The reaction usually generates heat, and the crystalline allophanate precipitates. Apparently, in the course of the reaction dicyanic acid is formed, which, at the moment of formation, combines with the alcohol to yield the allophanate (carbamylurethane):

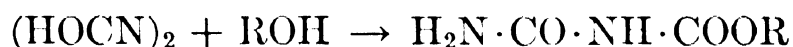

The precipitated crystals are separated and washed with ether to remove unchanged alcohol. The separated allophanate may contain small amounts of urethane and cyanuric acid as impurities. These can be separated by recrystallization. The crude crystals are dried until the odor of cyanic acid disappears, and then recrystallized. (Absolute ethyl alcohol, benzene, or acetone are best for this purpose.)

Most allophanates are odorless and colorless, and only sparingly soluble in cold ether. They are somewhat more soluble in cold ethyl alcohol.

Allophanates have been prepared for the identification of 3-hexenol, 2,6-nonadien-1-ol, geraniol, nerol, lavandulol, citronellol, isopulegol, menthol, santalol, fusanol, eudesmol, and cinnamic alcohol, among many others. Linalool and terpineol do not form allophanates.

5. Xanthates (Xanthogenates)

Xanthates are ester-salts of dithiocarboxylic acid. They are often useful in the identification of primary, secondary, and certain tertiary alcohols. One advantage of their use lies in the fact that they are reaction products of reagents which can be found in almost every laboratory, viz., carbon disulfide and potassium hydroxide. The reaction proceeds according to the following equation:

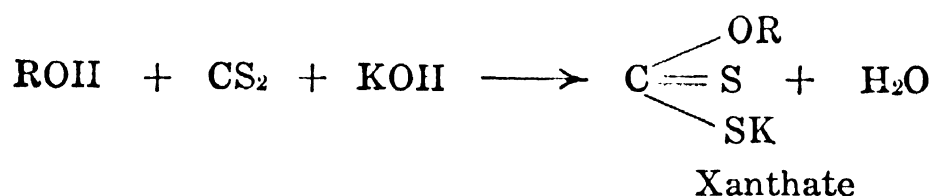

Tschugaev³⁴ employed the xanthate reaction for the preparation of characteristic derivatives of certain terpene alcohols. According to Whitmore and Lieber³⁵ the alkali xanthates are prepared as follows:

Add 1.0 equimolar quantity of pulverized potassium hydroxide to 1.5 equimolar quantity of the purified alcohol. Heat the mixture with stirring until the alkali is dissolved. After cooling, an equal volume of dry ether is added; then 1.5 equimolar quantity of carbon disulfide is gradually added in small amounts with vigorous stirring. The xanthate is usually formed immediately as a yellow precipitate. After all carbon disulfide has been added, two additional volumes of ether are added and the derivative separated and washed with dry ether. The xanthate is recrystallized from ethyl alcohol or acetone. The xanthate may be precipitated by addition of dry ether.

For further identification, Whitmore and Lieber suggested titrating the alkali xanthate with standard iodine solution:

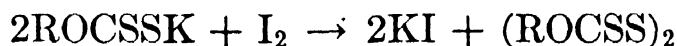

Xanthates of primary and secondary alcohols are stable in aqueous solution, but decompose slightly with evolution of hydrogen sulfide on prolonged boiling. The tertiary xanthates decompose rapidly on boiling in aqueous solution:

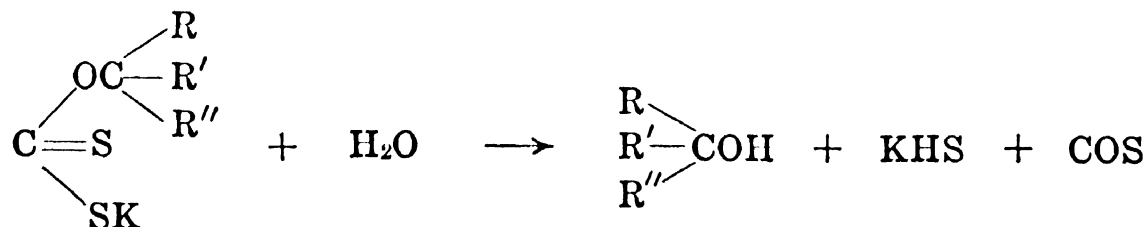

Tschugaev suggested the preparation of xanthic esters for the differentiation of primary, secondary, and tertiary alcohols. He converted the sodium xanthates into methyl esters of xanthic acid by using methyl iodide as reagent.

Distillation of the methyl xanthates results in their breakdown to unsaturated hydrocarbons, methyl mercaptan and carbon oxysulfide. This work is mentioned

here, since Tschugaev's method may afford a further means of identifying certain alcohols by means of their hydrocarbon derivatives.

Various other reagents have been found useful for the characterization of alcohols; these include:

- 2,4,6-Trinitrobenzoyl chloride³⁶
- 1-Nitroanthraquinone-2-carboxylic acid³⁷
- Pseudo-saccharin chloride (also for phenols)³⁸

- ¹ *J. Am. Chem. Soc.* **66** (1944), 1120.
- ² See Kamm, *J. Am. Chem. Soc.* **42** (1920), 299.
- ³ *Bull. soc. chim.* [4], **41** (1927), 788.
- ⁴ Anton Deppe Söhne and Zeitschel, German Patent No. 444,640 (August 12, 1924), No. 448,419 (December 14, 1924); British Patent No. 252,570 (June 3, 1926). Kaufmann, French Patent No. 702,154 (August 6, 1930).
- ⁵ French Patent No. 702,154 (August 6, 1930).
- ⁶ *Chem. Ztg.* **52** (1928), 898.
- ⁷ Anton Deppe Söhne and Zeitschel, German Patent No. 444,640 (August 12, 1924), No. 448,419 (December 14, 1924); British Patent No. 252,570 (June 3, 1926).
- ⁸ *J. Chem. Soc.* **91** (1907), 2058; **99** (1911), 58; **103** (1913), 1937.
- ⁹ *Riechstoff Ind.* **3** (1928), 175.
- ¹⁰ *J. Am. Chem. Soc.* **61** (1939), 2909.
- ¹¹ *Ibid.*
- ¹² *Ibid.*
- ¹³ *Ibid.* **47** (1925), 2348. Cf. also G. M. Dickinson, L. H. Crosson and J. E. Copenhaver, "Identification of Alcohols by 3-Nitrophthalic Anhydride," *ibid.*, **59** (1937), 1094.
- ¹⁴ *Ibid.* **58** (1936), 1384.
- ¹⁵ *Ber.* **17** (1884), 2544.
- ¹⁶ *Ibid.* **19** (1886), 3218.
- ¹⁷ *J. Am. Chem. Soc.* **65** (1943), 2252.
- ¹⁸ "Organic Reagents for Organic Analysis," Chemical Publishing Co., New York (1946), 48. Cf. also Reichstein, *Helv. Chim. Acta* **9** (1926), 799.
- ¹⁹ *J. Am. Chem. Soc.* **64** (1942), 1978.
- ²⁰ *Ber. Schimmel & Co.*, Oct. (1906), 32.
- ²¹ Staff of Hopkin and Williams, "Organic Reagents for Organic Analysis," Chemical Publishing Co., New York (1946), 62.
- ²² *J. Am. Chem. Soc.* **53** (1931), 1601.
- ²³ *Ibid.*, 3186.
- ²⁴ *Rec. trav. chim.* **54** (1935), 505. Re *o*-Nitrophenylisocyanate, see also van Hoogstraten, *Rec. trav. chim.* **51** (1932), 414. *Chem. Abstracts* **26** (1932), 3201.
- ²⁵ *Monatsh.* **63** (1933), 377.
- ²⁶ *J. Chem. Soc. Japan* **52** (1931), 77.
- ²⁷ *Rec. trav. chim.* **52** (1933), 969.
- ²⁸ *J. Am. Chem. Soc.* **69** (1947), 2470.
- ²⁹ "The Systematic Identification of Organic Compounds," 3d. Ed., John Wiley, New York (1948), 164.
- ³⁰ *Rec. trav. chim.* **58** (1939), 12.
- ³¹ *J. Chinese Chem. Soc.* **13** (1946), 22.
- ³² *Rec. trav. chim.* **61** (1942), 149.
- ³³ *Bull. soc. chim.* [4], **25** (1919), 479.
- ³⁴ *Ber.* **32** (1899), 3332.
- ³⁵ *Ind. Eng. Chem., Anal. Ed.* **7** (1935), 127. Cf. Sharpe, *J. Assocn. Official Agr. Chem.* **25** (1942), 495.
- ³⁶ Chang and Kao, *J. Chinese Chem. Soc.* **3** (1935), 256.
- ³⁷ Sah and Ma, *J. Chinese Chem. Soc.* **1** (1933), 51. *Chem. Abstracts* **27** (1933), 5737.
- ³⁸ Meadoc and Reid, *J. Am. Chem. Soc.* **65** (1943), 457.

III. ALDEHYDES AND KETONES

The derivatives of aldehydes and ketones most useful for identification purposes are those reaction products typical of the carbonyl group.

As the molecular weight of the radicals attached to the carbonyl group increases, the reactivity generally decreases, particularly if the compounds belong to the same homologous series.

The aldehydes—characterized by a hydrogen atom attached to the carbonyl group—usually show a greater reactivity than the ketones, a fact which may be taken advantage of in distinguishing between aldehydes and ketones.

There are many reactions which are typical of carbonyl compounds. The reagent employed for these reactions usually contains active hydrogen, which reacts with the oxygen of the carbonyl group. Some of these typical reactions are addition reactions, such as the cyanhydrin reaction (which takes place upon the addition of hydrocyanic acid), the bisulfite addition reaction, the ammonia reaction (addition of ammonia usually to aldehydes), the Grignard reaction, and the aldol condensation.

Many of these reactions are of great importance for the preparation of synthetic compounds. Certain other condensation reactions (often accompanied by elimination of the elements of water)—for example, hydroxylamine, hydrazine, and hydrazide reactions are of general interest for the identification of aldehydes and ketones and will be discussed here in the following order:

- A. Reactions and Reaction Products of Help in the Differentiation of Aldehydes from Ketones, as well as in the Identification of Aldehydes
 - 1. Oxidation
 - 2. Condensation
 - (a) Some General Reactions of Aldehydes
 - (b) Dimedone Reaction
 - (c) Doebner Reaction
 - (d) Cyanoacetic Acid Reaction
- B. Reactions and Reaction Products of Help in the Identification of Aldehydes and Ketones
 - 1. Reactions Typical Only of Aldehydes and Certain Ketones (Methyl Ketones and Ketomethylene Compounds)
 - (a) Reactions of Ketomethylene Compounds with Benzaldehyde
 - (b) Reactions with Sodium Bisulfite (or Sodium Sulfite)
 - 2. Reactions Characteristic of Both Aldehydes and Ketones
 - (a) Reactions with Hydroxylamine (Oximation)
 - (b) Reactions with Hydrazine Compounds
 - 1. Hydrazine and Substituted Hydrazines
 - 2. Hydrazides (= Acyl Hydrazine)
 - 3. Hydrazides with Quaternary Ammonium Function (Girard Type Reagents)
 - 4. Semicarbazides (= Carbamyl Hydrazines) and Substituted Semicarbazides
 - (c) Reactions with Sodium (or Potassium) Cyanide and Ammonium Carbonate (to Form Hydantoin Derivatives)

A. REACTIONS AND REACTION PRODUCTS OF HELP IN THE DIFFERENTIATION OF ALDEHYDES FROM KETONES, AS WELL AS IN THE IDENTIFICATION OF ALDEHYDES

1. Oxidation.—The hydrogen of the aldehyde group is very readily oxidized to a hydroxyl group, forming an acid. Ketones are oxidized only with difficulty; in the aliphatic series the molecule is split at the carbonyl group position, so that two acids are generally formed. In special cases these acids constitute useful identification products. This difference in the ease of oxidation offers, therefore, a means of differentiation between aldehydes and ketones.

Many salts of heavy metals act as mild oxidizing agents on aldehydes, a fact taken advantage of in several tests used to differentiate aldehydes from ketones (Tollen's reagent and Fehling's solution). Another well-known and very sensitive test (the Fuchsin test) is based upon a color reaction with Schiff's reagent.

Many aldehydes are oxidized by mere exposure to atmospheric oxygen. Oxidation may yield a solid acid, especially in the case of aromatic aldehydes. The acids may then be characterized by determination of the melting point, neutralization equivalent, etc. For further details about oxidation, the reader is referred to the section on "Hydrocarbons," p. 774.

2. Condensation.—

(a) *Some General Reactions of Aldehydes.*—Aldehydes tend to polymerize more readily than ketones. To prevent polymerization, care must, therefore, be exercised in the separation of aldehydes and in the preparation of derivatives.

Condensation reactions are generally carried out in an alkaline medium. Many of these reactions (such as aldol condensation and the Cannizzaro reaction) have been described in literature. Although these reactions are of importance primarily for synthesis, they may serve for the identification of aldehydes and ketones in special cases.

(b) *Dimedone Reaction.*—One reaction often used to distinguish certain aldehydes from ketones is the condensation reaction with dimedone (5,5-dimethyl-cyclohexane-1,3-dione). Aldehydes combine with dimedone according to the equation:

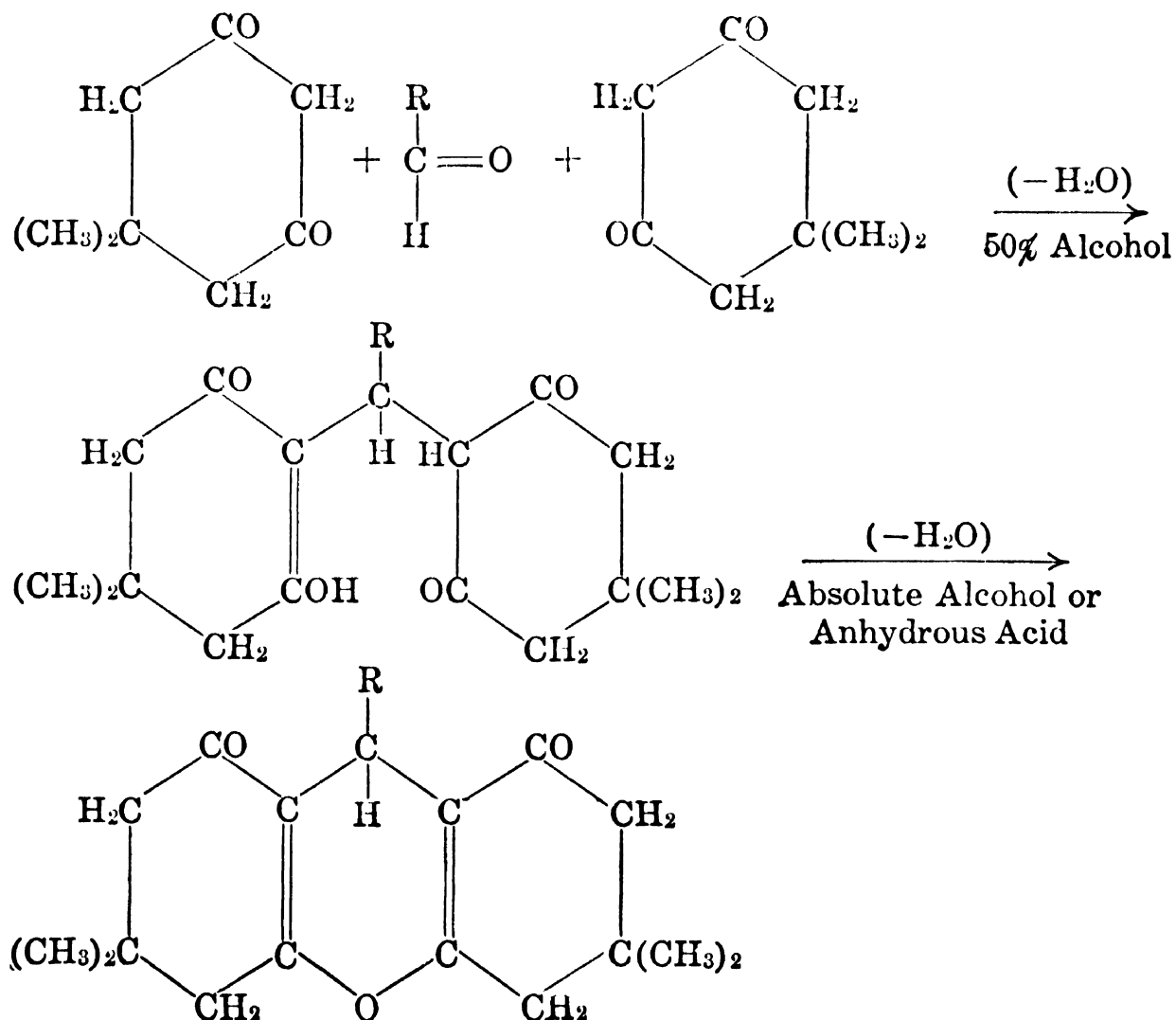

Since ketones will not react with dimedone under the same experimental conditions, the reagent may be regarded as specific for aldehydes. The condensation products are usually crystalline compounds which may serve as identification products for many aldehydes. The dimedone derivatives are soluble in dilute alkali. If these reaction products are further treated with dehydration agents (for example, acetic anhydride or sulfuric acid), a further derivative is formed having a condensed ring structure, such as the one shown in the last formula of the above equation. These latter products which Vorländer¹ named "anhydrides" are also useful for identification purposes.

One advantage in connection with dimedone as a reagent lies in the fact that it provides two derivatives from every aldehyde, and since dimedone does not react with ketones it may be of special value where mixtures are concerned.

The reagent dimedone is a white crystalline substance melting at 147°; sparingly soluble in cold water, but considerably more soluble in hot water. It is relatively soluble in alcohol.

For the preparation of dimedone derivatives, the following procedure may be used:

The aldehyde is added to a solution containing 2 mol equivalents of dimedone in 50% alcohol. The mixture is warmed and allowed to stand at room temperature for some time (2–3 hr.), until the derivative precipitates in the form of glistening crystals. The crystals are then separated and recrystallized from a suitable solvent, such as dilute alcohol. If undiluted or absolute alcohol is used for the reaction or recrystallization, the above-mentioned ring closure may take place.

Warming the derivatives with mineral or acetic acid, or acetic anhydride will usually cause the so-called "anhydride" to form.

(c) *Doebner Reaction*.—Doebner developed a reaction, specific for aldehydes, which may be of use in distinguishing aldehydes from ketones. His method is especially useful for the preparation of derivatives of aldehydes occurring in essential oils. In Doebner's method, aldehydes are made to react with β -naphthylamine and pyruvic acid in ether or alcohol solution, yielding the so-called " α -alkyl (or aryl)- β -naphthocinchonic acids."

Doebner reported the following reaction [see also *Beilstein* **22** (101–111)]:

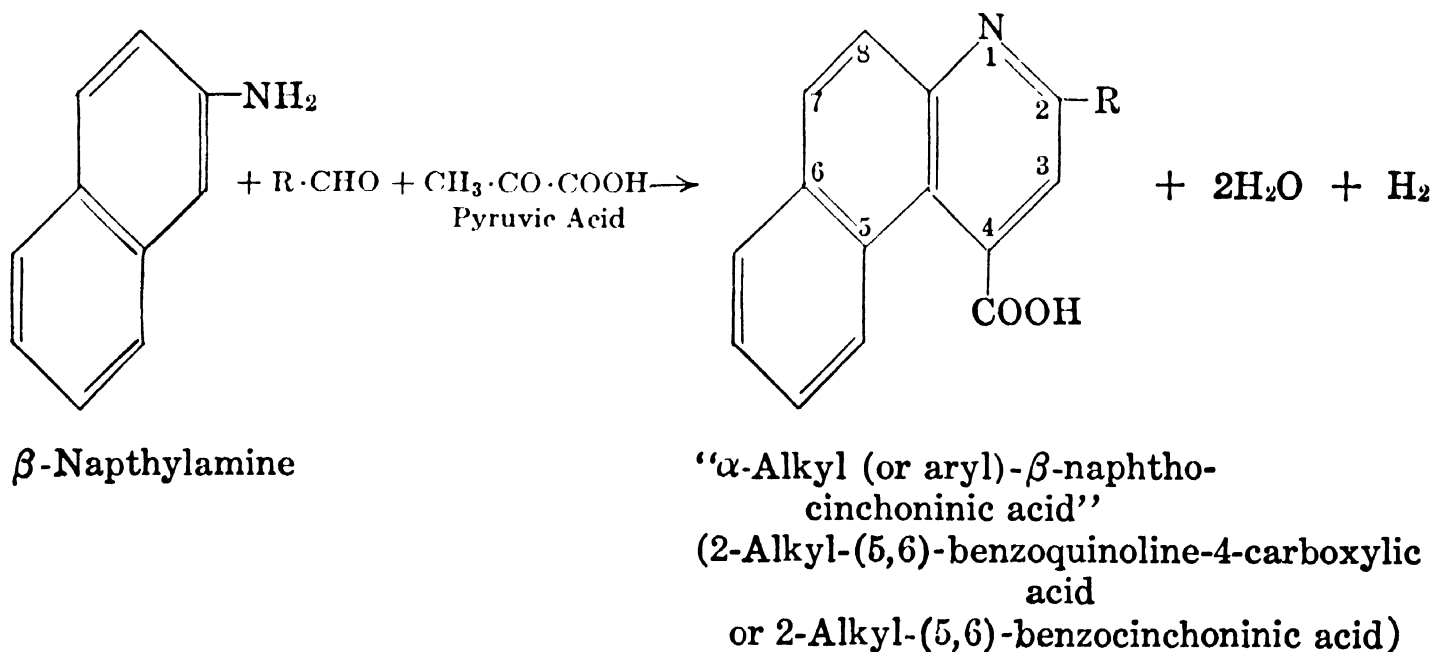

The melting points of these " β -naphthocinchonic acid" derivatives are generally very high, ranging from 200°–300°. When heated above their melting points, these derivatives readily split off carbon dioxide and yield organic bases, the so-called " α -alkyl (or aryl)- β -naphthoquinoline."

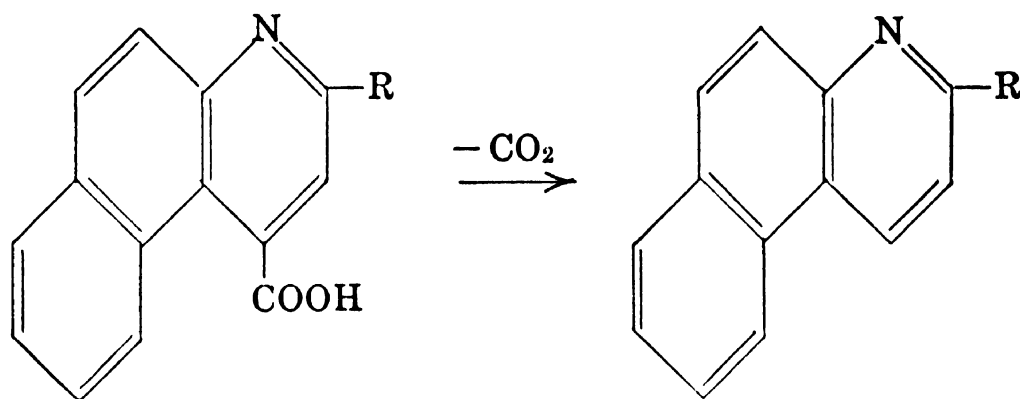

These quinoline bases may serve as additional identification products for the aldehydes, since they are easily prepared and possess well-defined, but much lower, melting points (usually 50° – 100°).

For many " β -naphthocinchoninic acid" derivatives, Doebner has prepared the silver salt of the acid, and a gold or platinum chloride addition product of the base. An additional advantage in the use of these derivatives lies in the fact that they can be employed to determine the molecular weight equivalent of the aldehyde under investigation.

If pyruvic acid is reacted with β -naphthylamine in the absence of aldehydes, " α -methyl- β -naphthocinchoninic acid," m. 310° , is formed (Doebner). Upon heating, this acid can be converted into the corresponding α -methylquinoline m. 82° .

In the presence of aldehydes, however, this reaction does not take place; instead of the methyl group, the organic radical of the aldehyde is attached in the α -position. The reaction takes place readily even in the cold, especially in ethereal solution. Doebner² recommended the following method:

Pyruvic acid (1 mol equivalent) and slightly more than an equimolar quantity of the aldehyde (or the oil fraction rich in aldehyde) are dissolved in absolute alcohol, and a solution of β -naphthylamine (1 mol equivalent) in absolute alcohol is added. The mixture is then refluxed for about 3 hr. On cooling, the " α -substituted β -naphthocinchoninic acid" usually crystallizes.

In a few cases, these crystals do not form readily. It is then advisable to dissolve the " β -naphthocinchoninic acid" in ammonia and to filter it, removing impurities and by-products. The ammoniacal filtrate is then neutralized with acid (for example, acetic acid) to precipitate the " α -substituted β -naphthocinchoninic acid," which can then be separated and recrystallized. The separated crystals are best washed with a small amount of ether and recrystallized from alcohol, ether, or water.

They can also be easily recrystallized as hydrochlorides from a hot solution of alcohol and concentrated hydrochloric acid. These products are usually light yellow to orange in color, and upon boiling with water, or upon heating to about 120° , lose the hydrogen chloride molecule.

Doebner prepared " β -naphthocinchoninic acid" and " β -naphthoquinoline" derivatives for the following aldehydes: citronellal, propion-, acet-, isopropyl-, isobutyl-, isovaleric-, hept-, allyl-, croton- and tiglic aldehyde, citral, furfural, anisaldehyde, vanillin, piperonal, and cuminal.

(d) *Cyanoacetic Acid Reaction*.—Tiemann³ has investigated the reaction between certain aldehydes (citral and citronellal, for example) and cyanoacetic acid.

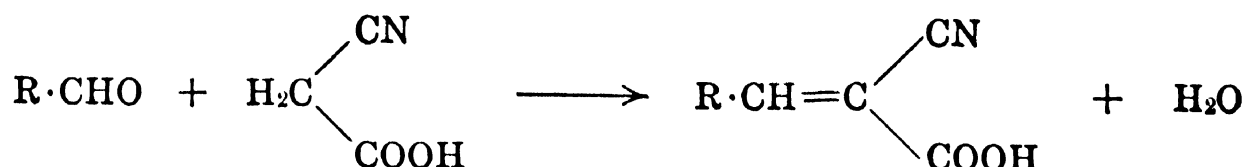

If these condensation products are easily crystallized and have well-defined melting points, they may serve for the identification of the aldehyde. (For more details, see pp. 330 and 339.)

B. REACTIONS AND REACTION PRODUCTS OF HELP IN THE IDENTIFICATION OF ALDEHYDES AND KETONES

1. **Reactions Typical Only of Aldehydes and Certain Ketones (Methyl Ketones and Ketomethylene Compounds).**—Ketones possessing a methylene group adjacent to the carbonyl group (*ketomethylene compounds*) show an increased reactivity. (*Methyl ketones* can be considered a special type of ketomethylene compound.) The hydrogen of the carbon adjacent to the carbonyl group has an increased mobility and such a ketone can change into the enolic form, which is very active in many reactions—oxidation, condensation, halogenation, etc.

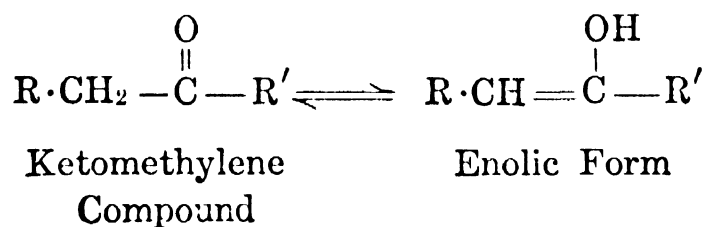

The hydrogen of the OH group in the enolic form may be replaced by sodium when ketomethylene compounds are treated with alkalis (sodium ethylate, for example). Such compounds are of considerable importance in the preparation of synthetic compounds.

(a) *Reactions of Ketomethylene Compounds with Benzaldehyde.*—Compounds con-

taining a ketomethylene group ($-\text{CH}_2-\overset{\text{O}}{\parallel}\text{C}-$) often form crystalline condensation products with benzaldehyde. These reaction products may be useful as derivatives to characterize the original ketone.

The number of mols of benzaldehyde necessary for the reaction will depend upon whether the ketomethylene compound has one or two methylene groups adjacent to the carbonyl group ($\text{R} \cdot \text{CH}_2 \cdot \text{CO} \cdot \text{R}'$ or $\text{R} \cdot \text{CH}_2 \cdot \text{CO} \cdot \text{CH}_2 \cdot \text{R}'$).

For the preparation of these derivatives, the following procedure may be employed:

The ketomethylene compound is added to slightly more than the equimolar quantity of benzaldehyde and is dissolved in a small quantity of absolute alcohol. For 1 g. of ketomethylene compound it may be necessary to use about 10 cc. of absolute alcohol. Then 0.5 cc. of 20% sodium hydroxide solution is added, and the mixture allowed to stand for 1 hr. or longer at room temperature. Arylidene derivatives usually crystallize readily if the wall of the reaction vessel is scratched lightly with a glass rod. The crystalline precipitate is then separated by filtration, best washed with cold alcohol, and recrystallized from a suitable solvent such as absolute alcohol.

(b) *Reactions with Sodium Bisulfite (or Sodium Sulfite).*—The formation of sodium bisulfite addition products is very important for the quantitative determination of many aldehydes and ketones (see Vol. I, pp. 279 ff.). As crystalline derivatives for qualitative test and identification by melting point, sodium bisulfite addition products are not satisfactory. However, for the isolation and purification of aldehydes and certain ketones, the crystalline addition products are often useful. They are formed

readily in mixtures rich in aldehydes or certain ketones, and the original carbonyl compound may often be regenerated from them.

If an aldehyde (or ketone) contains an ethylenic linkage in addition to the carbonyl group—for example, citral, citronellal, cinnamic aldehyde and carvone—2 mols of sodium bisulfite may be added to the compound. Regeneration from this type of addition compound is not always possible (for example, citral, see p. 328); furthermore regeneration, if at all possible, may not be quantitative.

The sodium bisulfite addition product may be prepared as follows:

The aldehyde (or ketone), if liquid, is vigorously shaken with an equal volume of a concentrated solution (about 40%) of sodium bisulfite. If the substance to be tested is a solid, a solution should be employed (for example, in ether). The reaction frequently evolves heat; it is often necessary, however, to apply heat in order to accelerate the reaction. The sodium bisulfite addition product solidifies either at once or after being cooled and shaken. If, instead of sodium bisulfite, a saturated aqueous solution of sodium sulfite (about 30%) is used for the formation of the addition product, the sodium hydroxide formed by the reaction should be neutralized at once—for example, with dilute acetic acid; the sodium bisulfite addition product formed may then be separated and further purified by recrystallization.

Many sodium bisulfite addition products are quite soluble in water and are therefore difficult to separate as crystalline compounds.

The regeneration of the aldehyde (or ketone) from the purified sodium bisulfite addition product may be effected quite easily by treatment with aqueous solution of acids, such as oxalic or dilute sulfuric acid, or with alkalis, preferably with alkali carbonate. Usually, regeneration with alkali is to be preferred, since the addition of acid liberates free SO_2 .

In some cases, however, regeneration with acid will be more advantageous; for example, for aldehydes sensitive to alkali, or for phenolic aldehydes.

2. Reactions Characteristic of Both Aldehydes and Ketones.—Primary amines, possessing active hydrogen, react readily with aldehydes or ketones. Certain amines which form crystalline compounds with aldehydes or ketones are, therefore, very useful reagents in the preparation of derivatives for identification purposes.

(a) *Reactions with Hydroxylamine (Oximation).*—The inter-reaction of aldehydes or ketones with hydroxylamine yields oximes which are employed to characterize many carbonyl compounds. Often, however, these derivatives possess rather low melting points and may be so readily soluble as to be difficult to purify. As a general rule, aldehydes readily form oximes in quantitative yields; ketones, however, react more slowly. This is especially true of numerous terpenic ketones, particularly pino-carvone and carvopinone which do not form quantitatively. The reaction between carbonyl compounds and hydroxylamine is reversible, and care must be taken to avoid unnecessary contact with strongly acidic solutions.

Since the oximes belong to the "older" group of derivatives, they have been described quite thoroughly in literature.

Oximation has become important for the quantitative determination of carbonyl compounds (see Vol. I, p. 286).

The following procedure may be employed for a carbonyl compound:

One gram of aldehyde is dissolved in 5 cc. of alcohol and mixed with a solution of 1 g. of hydroxylamine hydrochloride and 2 g. of sodium acetate in 3 cc. of water. A little more alcohol may be added, if necessary, to complete solution of the aldehyde. The mixture is allowed to stand for $\frac{1}{2}$ to 1 hr. On cooling, the oxime usually crystallizes.

With aliphatic aldehydes it is best to use sodium acetate as buffering agent. With aromatic aldehydes it is advantageous to employ an excess of sodium hydroxide, but the latter will need subsequent neutralization to precipitate the oxime.

Ketoximes are not formed as readily as aldioximes and long standing or refluxing is generally required.

When an excess of hydroxylamine hydrochloride is necessary—as with certain aromatic aldehydes or ketones—the best solvent is alcohol. The oxime may be separated from the reaction mixture by neutralization of any excess soda, and dilution of the alcoholic liquids with water. The more soluble oximes may be extracted with ether from the aqueous solution. Alcohol, and dilute alcohol, among others, are solvents suitable for recrystallization.

Shriner and Fuson⁴ suggest the use of 5 cc. pyridine and 5 cc. absolute alcohol for 1 g. of aldehyde or ketone and 1 g. of hydroxylamine hydrochloride. The solvents are removed by evaporation and the residue triturated thoroughly with 5 cc. of cold water. The oxime is then filtered off and recrystallized.

On oximation stereoisomeric oximes may form; in such cases careful purification must be resorted to so that the desired oxime will be obtained. (Cf. also: "Stereoisomerism of Alicyclic Oximes," W. Hüchel and M. Sachs, *Liebigs Ann.* **498** (1932), 166. *Chem. Abstracts* **27** (1933), 72. "Relative Proportions of Stereoisomeric Oximes Formed in the Oximation of Unsymmetrical Ketones," W. E. Bachmann and M. X. Barton, *J. Org. Chem.* **3** (1938), 300.) With certain carbonyl compounds it may be necessary to use an exactly calculated amount of hydroxylamine. Even when this is done, however, an additional hydroxylamine molecule may sometimes be added to the oxime ($=\text{NOH}\cdot\text{NH}_2\text{OH}$), and a hydroxylamino-oxime (occasionally referred to, especially in German literature, as "oxamine-oxime") may be formed. Such products have been reported for carvotanacetone, santolinone, piperitone, verbenone, carvone, pulegone, etc. According to some investigators, certain ketones, for example, pulegone (see p. 401), will produce different compounds when reacted with hydroxylamine, depending upon experimental conditions.

The separated oxime can often be reconverted to the original aldehyde or ketone. This fact may prove useful for the isolation and purification of certain ketones, especially for those which do not form sodium bisulfite addition products.

The regeneration of the carbonyl compound from the oxime can be accomplished by heating the oxime with dilute acid, such as sulfuric acid, and separating the ketone, either by distillation or extraction.

Isolation by means of oximation has been reported for the ketones, such as menthone, pinocamphone, and jasmone.

(b) *Reactions with Hydrazine Compounds.*—Hydrazine (diamine, $\text{H}_2\text{N}\cdot\text{NH}_2$) condenses with aldehydes and ketones. Hydrazine itself is very rarely used as a reagent; more often substituted hydrazines are employed. All hydrazine reagents react in the same manner:

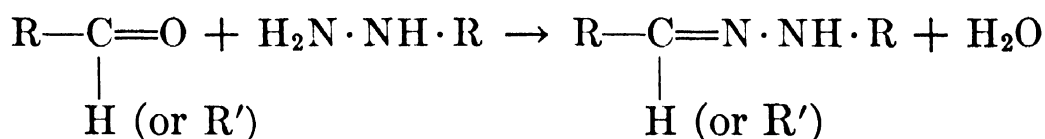

There are a great variety of substituted hydrazine reagents. They are alike in that they possess one amino group of which the active hydrogens react with the carbonyl groups. The difference between them lies in the fact that a variety of organic radicals can be substituted for the hydrogen of the other amino group. The nature of the substituted group will determine the properties of the compounds formed by the reaction of aldehydes and ketones with substituted hydrazine reagents.

The following types of hydrazine compounds will form derivatives which may be useful for the identification of carbonyl compounds:

$R \cdot HN \cdot NH_2$	Substituted hydrazine
$R \cdot CO \cdot HN \cdot NH_2$	Hydrazide = acyl hydrazine
$ \begin{array}{c} R' \\ \diagdown \\ R'' - N - CH \cdot CO \cdot HN \cdot NH_2 \\ \diagup \quad \quad \\ R''' \quad X \quad R \end{array} $	Hydrazide with quaternary ammonium function (the Girard type reagents) (X stands for halogen or an acid radical)
$ \begin{array}{cccc} H_2N \cdot CO \cdot HN \cdot NH_2 \\ 4 \quad 3 \quad 2 \quad 1 \end{array} $	Semicarbazide = carbamyl hydrazine (hydrazine carboxylamine)
$R \cdot HN \cdot CO \cdot HN \cdot NH_2$	4-Substituted semicarbazide
$ \begin{array}{cccc} H_2N \cdot CO \cdot CO \cdot HN \cdot NH_2 \\ 5 \quad 4 \quad 3 \quad 2 \quad 1 \end{array} $	Semioxamazide (= oxalic amide hydrazide)
$R \cdot HN \cdot CO \cdot CO \cdot HN \cdot NH_2$	5-Substituted semioxamazide
$ \begin{array}{c} H_2N \cdot C \cdot HN \cdot NH_2 \\ \\ NH \end{array} $	1-Aminoguanidine (= guanylhydrazine)

The semicarbazide derivatives are generally not considered substituted hydrazones—they are referred to as semicarbazones.

The semioxamazide derivatives are known as semioxamazones.

1. Hydrazine and Substituted Hydrazines.—Among the most useful derivatives serving for the identification of aldehydes and ketones are the hydrazones; the substituted hydrazines most commonly employed as reagents being phenyl-, *p*-nitrophenyl-, and 2,4-dinitrophenylhydrazine.

Since the phenylhydrazones frequently possess very low melting points and are difficult to crystallize, it is advisable to prepare, in their stead, the *p*-nitro-, or still better, the 2,4-dinitrophenylhydrazones which usually exhibit well-defined melting points. In fact, the latter are now generally preferred for the identification of carbonyl compounds.

For the preparation of *phenylhydrazones*, phenylhydrazine hydrochloride can be employed as a reagent. This is a white, or pale yellow, crystalline powder, which turns brown, and becomes unfit for use, if exposed to air and light. It is soluble in water and alcohol.

Phenylhydrazones may be prepared as follows:

The aldehyde or ketone should be dissolved in a little alcohol and added to an excess of phenylhydrazine solution. (This is prepared by dissolving 1 g. of phenylhydrazine hydrochloride and 1.5 g. of sodium acetate in 10 cc. of water.) The reaction mixture is warmed on a steam bath for about 30 min. More alcohol is added, if necessary, to dissolve the aldehyde or ketone. The phenylhydrazones on cooling often separate first as oils. Purification may be effected by recrystallization from a suitable solvent, such as alcohol, dilute alcohol, benzene, petroleum ether, or water.

The liquid phenylhydrazine, as such, is often employed as a reagent for the preparation of phenylhydrazones; but the hydrochloride is more stable and more convenient to handle. When phenylhydrazine is used as reagent, the addition of a few drops of a solution in 30 to 50 per cent aqueous acetic acid is frequently employed, the acid acting as a catalyst.

In many cases, the original aldehyde or ketone can be regenerated from its phenylhydrazone by heating with dilute acids. This method, therefore, may be advantageous in special cases, for the separation and purification of certain carbonyl compounds.

The reaction with phenylhydrazine may also serve for the quantitative determination of aldehydes and ketones (see Vol. I, p. 284).

Some substances require a considerable departure from the usual procedure for the preparation of phenylhydrazones; in such cases, the use of another reagent is advisable. Many phenylhydrazones, with loss of ammonia, tend to transform into indole derivatives, and it is therefore necessary to determine their melting points without delay.

α -Hydroxy aldehydes and α -hydroxy ketones react with 2 mols of phenylhydrazine yielding *osazones*;* thus the α -hydroxy group is oxidized and condenses with the second molecule of phenylhydrazine. α -Diketones react normally, yielding mono- and di-hydrazones (*osazones*), while β -diketones yield pyrazoles.

p-Nitrophenylhydrazones are prepared with *p*-nitrophenylhydrazine, an orange crystalline solid melting at 157°; it decomposes slowly if exposed for a long time at room temperature, but may safely be stored in a refrigerator for an indefinite period of time. It is sparingly soluble in cold water but easily soluble in hot water. It represents a convenient reagent for aldehydes and ketones and forms derivatives of which the melting points are generally well defined, at a range considerably above room temperature.

p-Nitrophenylhydrazones may be prepared as follows:

Equimolar amounts of the aldehyde (or ketone) and *p*-nitrophenylhydrazine are dissolved in glacial acetic acid and refluxed for 15 to 30 min. The derivative usually crystallizes out on cooling, or upon careful dilution with water. The crystals are then separated and recrystallized from a suitable solvent, such as alcohol, acetic acid, or nitrobenzene.

2,4-Dinitrophenylhydrazones are prepared with 2,4-dinitrophenylhydrazine, a red crystalline solid melting at 195°–196°. It is very sparingly soluble in water, and only slightly soluble in cold organic solvents. The derivatives formed are usually high melting and are obtained in good yield. Under standard conditions the reaction may also prove advantageous for the quantitative estimation of carbonyl compounds by gravimetric methods.

According to Shriner and Fuson,⁵ the preparation of 2,4-dinitrophenylhydrazones may be carried out as follows:

“A solution of 2,4-dinitrophenylhydrazine is prepared in the following fashion. To 0.4 g. of 2,4-dinitrophenylhydrazine in a 25-ml. Erlenmeyer flask is added 2 ml. of concentrated sulfuric acid. Water (3 ml.) is added dropwise, with swirling or stirring until solution is complete. To this warm solution is added 10 ml. of 95% ethanol.

A solution of the carbonyl compound in ethanol is prepared by dissolving 0.5 g. of the compound in 20 ml. of 95% ethanol. The freshly prepared 2,4-dinitrophenylhydrazine solution is added, and the resulting mixture is allowed to stand at room temperature. Crystallization of the 2,4-dinitrophenylhydrazone usually occurs within 5 to 10 minutes. If no precipitate is formed, the mixture is allowed to stand overnight.”

The dinitrophenylhydrazone usually separates on cooling; only in exceptional cases is it necessary to reflux the reaction mixture for a few minutes. The crystals

* This reaction is especially important for the identification of the sugar compounds.

are then separated, washed with a small amount of absolute alcohol, and recrystallized from a suitable solvent, such as alcohol, glacial acetic acid, ethyl acetate, xylene, or nitrobenzene.

Allen ⁶ has reported a slightly different method of preparing 2,4-dinitrophenylhydrazones:

Five cc. of a saturated solution of 2,4-dinitrophenylhydrazine in alcohol (1 g. in 100 cc.) are added to a solution of a few drops of the carbonyl compound in alcohol, and the mixture is carefully heated to boiling. A few drops of concentrated hydrochloric acid are then added slowly. The color of the solution usually changes immediately to yellow or orange. The mixture is then boiled for about 2 min., and water added drop by drop until cloudiness or crystallization begins. The dinitrophenylhydrazones of certain ketones crystallize slowly from alcohol, but separate as oils on addition of water. The dinitrophenylhydrazone is filtered when the solution is cold and may be recrystallized from a suitable solvent—alcohol, ethyl acetate and alcohol, or chloroform.

Many other substituted hydrazines have been suggested as reagents for aldehydes and ketones by different investigators:

- p*-Bromophenylhydrazine hydrochloride (Biltz and Sieden ⁷)
- p*-Chlorophenylhydrazine hydrochloride (Sah et al. ⁸)
- 1-Methylphenylhydrazine (Stevens and Ward, ⁹ and Neuberg ¹⁰)
- 1-Benzyl-1-phenylhydrazine (van Ekenstein and Lobry de Bruyn, ¹¹ and Hofmann ¹²)
- asym*-Diphenylhydrazine hydrochloride (Fischer, ¹³ and Maurenbrecher ¹⁴)
- Carboxy methylhydrazine (Anchel and Schoenheimer ¹⁵)
- Carboxy phenylhydrazine (Veibel, Blaaberg, and Stevns ¹⁶)
- o*-Carboxy phenylhydrazine (Veibel et al. ¹⁷)
- m*-Carboxy phenylhydrazine (Willstätter et al. ¹⁸)
- p*-Carboxy phenylhydrazine (Anchel and Schoenheimer, ¹⁹ and Veibel et al. ²⁰)
- α -Naphthylhydrazine hydrochloride and β -naphthylhydrazine hydrochloride (Fischer ²¹)
- Aminoguanidine (= guanylhydrazine) (Baeyer ²²)
- Nitroguanylhydrazine (Whitmore et al. ²³)
- o*-Nitrophenylhydrazine and *m*-nitrophenylhydrazine (Bischler, ²⁴ and van Ekenstein and Blanksma ²⁵)
- Phenylhydrazine-*p*-sulfonic acid (Biltz, Maué and Sieden ²⁶)
- o*-Tolylhydrazine hydrochloride (Sah and Ma ²⁷)
- m*-Tolylhydrazine hydrochloride (Sah and Tseu ²⁸)
- p*-Tolylhydrazine hydrochloride (Sah and Lei ²⁹)
- 2,4,6-Trinitrophenylhydrazine (Purgotti ³⁰)
- p*-Xenylhydrazine (Müller ³¹)
- p*-Thiocyanophenylhydrazine hydrochloride (Horii ³²)

2. Hydrazides (= Acyl Hydrazine).—Hydrazides are acyl hydrazines of the general formula $R \cdot CO \cdot NH \cdot NH_2$.

The *p*-iodobenzhydrazide is a very useful reagent for the preparation of derivatives for aldehydes and ketones occurring in essential oils.

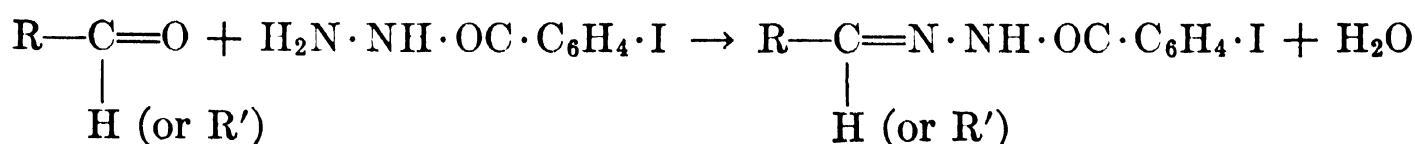

p-Iodobenzhydrazide is a crystalline substance melting at 168°–169°, soluble in alcohol, but only slightly soluble in water. (This reagent can be prepared from *p*-iodobenzoic methyl ester and hydrazine hydrate.) The hydrazones derived from this reagent are easily formed and generally possess high melting points. The *p*-iodobenzhydrazones may be prepared as suggested by Sah and Hsü: ³³

About 0.3 g. of *p*-iodobenzhydrazide and a slight molecular excess of the carbonyl compound to be tested are dissolved in 5 to 10 cc. of 95% alcohol. Two drops of glacial acetic acid, which act as a catalyst, are added. The mixture is then refluxed for 10 to 15 min. After cooling, the *p*-iodobenzhydrazones usually crystallize out. If this is not the case, some of the solvent may be evaporated. The crystals are separated and recrystallized from a suitable solvent, such as methyl alcohol, 50% or 95% ethyl alcohol, benzene, or petroleum ether.

Numerous other hydrazides have been used successfully as reagents for carbonyl compounds, many of them having been investigated by Sah and co-workers:

- o*-Bromobenzhydrazide (Sah et al. ³⁴)
- m*-Bromobenzhydrazide (Sah et al. ³⁵)
- p*-Bromobenzhydrazide (Sah et al. ³⁶)
- o*-Chlorobenzhydrazide (Sun and Sah ³⁷)
- m*-Chlorobenzhydrazide (Sah and Wu ³⁸)
- p*-Chlorobenzhydrazide (Shih and Sah ³⁹)
- o*-Nitrobenzhydrazide (Sah and Kao, ⁴⁰ and Sah and Yin ⁴¹)
- m*-Nitrobenzhydrazide (Strain, ⁴² and Sah and Kao ⁴³)
- p*-Nitrobenzhydrazide (Chen ⁴⁴)
- o*-, *m*-, and *p*-Nitrobenzene sulfonylhydrazide (Witte ⁴⁵)
- 3,5-Dinitrobenzhydrazide (Sah and Ma ⁴⁶)
- β -Naphthydrazide (Sah ⁴⁷)
- Oxanilhydrazide (Sah and Han ⁴⁸)
- l*-Menthylhydrazide (Woodward, Kohman and Harris ⁴⁹)

3. Hydrazides with Quaternary Ammonium Function (Girard Type Reagents).—The purpose of introducing a radical of quaternary ammonium function into the hydrazide reagent is to render the resulting carbonyl derivatives water soluble, and thus to facilitate their separation from other, water insoluble compounds. Reaction products of carbonyl compounds with hydrazides containing an acidic radical—carboxylic or sulfonic radicals, for example—are more readily soluble in water than hydrazones resulting from other substituted hydrazide derivatives.

Girard and Sandulesco ⁵⁰ have investigated quaternary ammonium salts of hydrazides and have successfully employed them for the preparation of water soluble hydrazones from carbonyl compounds. These hydrazides with quaternary ammonium function contain a pentavalent nitrogen. This nitrogen is not directly attached to the carbonyl group.

The following general formula can be written for these quaternary ammonium salts of hydrazides:

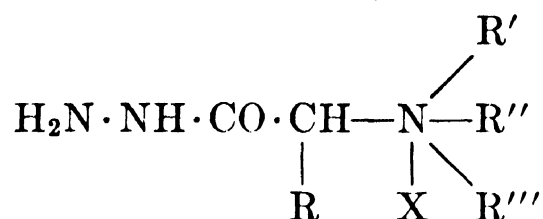

R may also stand for hydrogen; R', R'', and R''' and N may be part of a ring closure, as in the case of pyridine (Girard's Reagent P). This ring closure may also include

the carbon atom adjacent to the ammonium group (reagent of Allen and Gates, see below).

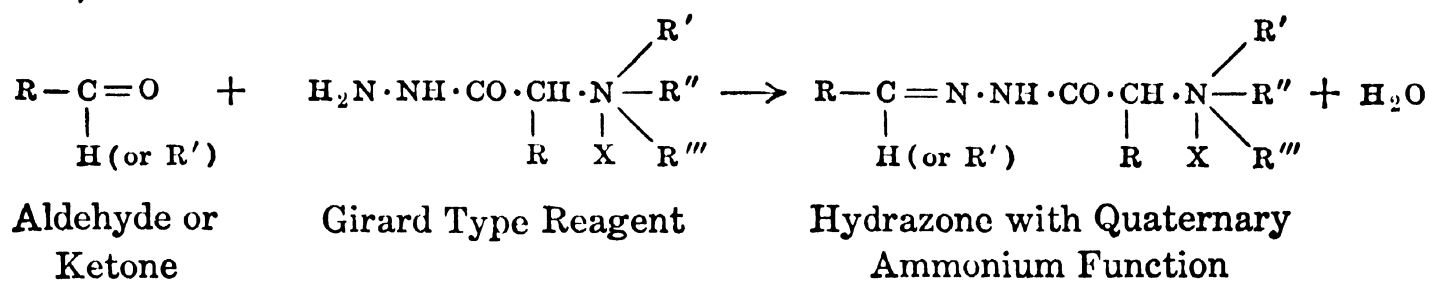

The two reagents recommended by Girard and Sandulesco are the following two substituted acetohydrazides:

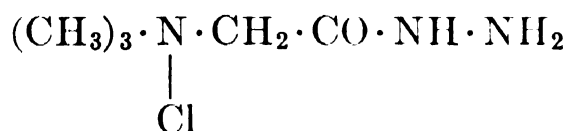

Trimethyl ammonium acetohydrazide chloride (*Girard's Reagent T*).

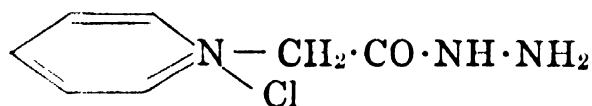

Pyridinium acetohydrazide chloride (*Girard's Reagent P*).

With aldehydes and many ketones, these two reagents form hydrazones rapidly and quantitatively. The hydrazones are soluble in water and alcohol but only very sparingly so in ether and other nonhydroxylic organic solvents. An aqueous solution containing these aldehyde or ketone derivatives can, therefore, be subjected to extraction with organic solvents, to separate water insoluble noncarbonyl compounds.

The ketones can usually be *regenerated* and recovered from the water soluble derivatives without much difficulty. The hydrazones formed with Reagents T and P are, as a rule, crystalline solids, which may be used for the identification of carbonyl compounds. They are hygroscopic, however, and possess no advantage over the reagents more commonly used. Their preparation for the purpose of isolation and purification of ketonic compounds is nevertheless very advantageous and has some industrial application. Patent literature is available.⁵¹

This interesting method permits the removal of large and small quantities (even traces) of carbonyl compounds from various natural products such as essential oils (Petit and Tallard,⁵² and Sandulesco and Sabatay⁵³).

The ketonic hydrazones formed with either of these reagents can be quantitatively hydrolyzed by dilute mineral acid, whereas the aldehydic hydrazones are essentially nonhydrolyzable under the same conditions. With this method, therefore, ketones can be separated not only from noncarbonyl compounds, but from aldehydes as well.

Girard and Sandulesco observed that the rate of hydrazone formation is a function of the structure of the ketone and arranged various types in the following approximate order of decreasing reactivity:

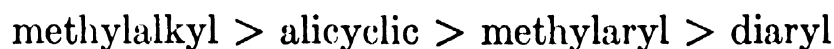

An accumulation of substituents adjacent to the carbonyl group also reduces the reactivity greatly (for example, dimethyl camphor does not react with Reagent T to form the desired product).

By taking advantage of this difference in reactivity, it may be possible not only to separate aldehydes from ketones but also to separate certain groups of ketones from one another.

noncarbonyl compounds. It is not necessary to neutralize this mixture since in the nonaqueous state hydrolysis cannot take place. After the ether has extracted all impurities, the original ketone may be regenerated by addition of a large volume of water, and acidification to approximate normality with sulfuric acid, following the same procedure as described before.

If the separation of a crystalline derivative for identification purposes is desired, it may be best to prepare a crystalline salt from the hydrazone of Reagent T. Hydrazones derived from Reagent T have the property of forming highly insoluble salts with certain inorganic compounds, such as mercuric iodide. These salts may be useful for the identification of carbonyl compounds, even when the latter occur only in small quantity. Girard and Sandulesco were able, by this means, to detect cinnamaldehyde in a concentration of only 30 gammas per milliliter. The following method was employed:

Ten cc. of the aqueous reaction mixture containing the water soluble hydrazone (see above) are freed completely from ether, then 1 cc. of mercuric iodide solution (5 g. mercuric iodide and 10 g. of potassium iodide to 500 cc. of water) is added. If this is not sufficient to precipitate all the hydrazone in solution, more mercuric iodide solution should be added. It is necessary, however, to use a very pure Reagent T for the preparation of these crystalline hydrazone salts.

Hughes⁵⁵ suggested a similar procedure for the quantitative determination of ketosteroids. Lederer⁵⁶ reported on the formation of azines from aromatic aldehydes in the presence of Girard and Sandulesco Reagents T and P.

Allen and Gates⁵⁷ employed a reagent similar to Girard's reagents. With it they prepared certain water soluble hydrazones, which they found to be more suitable for identification purposes than those obtained with Girard's reagent. The reagent that these investigators used successfully is the quaternary salt of nicotinic hydrazide with methyl-*p*-toluene sulfate: *the N-methyl-β-carbohydrazide pyridinium p-toluene sulfonate* (the hydrazide of 3-carboxy-1-methyl pyridinium *p*-toluene sulfonate)

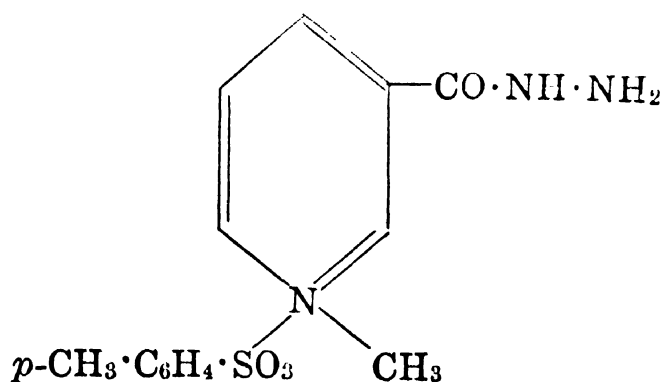

This reagent permits the preparation of derivatives possessing well-defined (usually high) melting points. These derivatives are soluble in water but almost insoluble in organic nonhydroxylic solvents.

The reagent may be used to separate carbonyl compounds from mixtures; the aldehydes as well as the ketones may be recovered from the water soluble hydrazones. The regeneration requires only short acid hydrolysis.

The reagent can be prepared by reacting ethyl nicotinate with methyl-*p*-toluene sulfonate and then with hydrazine hydrate in absolute alcohol. This reagent may be obtained in the stable form m. 155°–157° or in the metastable form m. 130°–131°. The derivatives of either form possess identical melting points.

The following procedure may be employed for the preparation of these derivatives:

A mixture of 3.2 g. (0.01 mol) of reagent, 0.01 mol of the carbonyl compound, and 15 cc. of absolute alcohol are refluxed for 15 min. On cooling, the derivative

that crystallizes is filtered off and recrystallized to constant melting point from a suitable solvent, such as absolute alcohol or alcohol-ether (1:1).

The regeneration of the aldehyde or ketone by acid hydrolysis may be carried out by adding dilute sulfuric acid to the hydrazone, heating to about 60° for 15 min., and extracting the carbonyl compound from the cooled solution with ether. The carbonyl compound may be further purified by distillation.

4. Semicarbazides (= Carbamyl Hydrazines) and Substituted Semicarbazides.—Semicarbazones are often useful for the identification of aldehydes and ketones. They are prepared by the reaction of these carbonyl compounds with semicarbazide hydrochloride ($\text{H}_2\text{N}\cdot\text{CO}\cdot\text{NH}\cdot\text{NH}_2\cdot\text{HCl}$). This reagent is a white crystalline compound m. 173°–175°, readily soluble in water, but practically insoluble in alcohol.

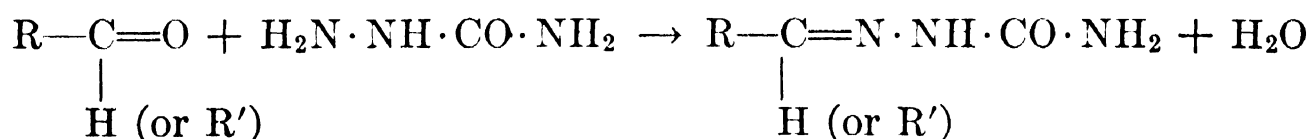

Preparation of the semicarbazones may be carried out as follows:

To an aqueous solution of the semicarbazide hydrochloride is added a molar equivalent of sodium acetate. To the solution is then added slightly less than the equimolar amount of the aldehyde or ketone. It may also be necessary to add alcohol to produce a clear solution. The semicarbazone usually crystallizes after standing for a few minutes at room temperature, although sometimes a longer period may be necessary. With certain ketones, heating may be required. For final purification, the semicarbazone should then be recrystallized from a suitable solvent, such as water, alcohol, or acetone.

Hopper⁵⁸ devised a method wherein the sodium acetate is conveniently replaced by pyridine in the following manner:

The aldehyde or ketone is dissolved in pyridine and an aqueous solution of semicarbazide hydrochloride added. The semicarbazone generally crystallizes readily from the aqueous pyridine solution.

A simpler method of preparing semicarbazones is recommended by Haagen-Smit:⁵⁹

Rub together the required amount of semicarbazide hydrochloride and sodium acetate with some alcohol. The sodium chloride will precipitate and can be filtered off. After addition of the carbonyl compound the semicarbazone which forms may be separated with no interference from the sodium chloride.

The original aldehyde or ketone can usually be recovered by heating with dilute acid (oxalic, sulfuric, etc.). For this reason semicarbazones may also be used for isolation purposes.

Substituted semicarbazones, although frequently employed, offer no significant advantage over semicarbazones except that they are usually higher melting. Thus, the 4-phenylsemicarbazones are frequently used for identification of carbonyl compounds occurring in essential oils. These derivatives crystallize well and have sharply defined melting points.

The reagent 4-phenylsemicarbazide is a white crystalline substance melting at 120°–123°.

The 4-phenylsemicarbazones may be prepared as follows:

A solution of 0.5 g. of the 4-phenylsemicarbazide in 5 cc. of alcohol is acidified with a few drops of acetic acid. To it is added a solution containing the molecular equivalent of the aldehyde or ketone in 5 cc. of alcohol. The mixture is heated

for a few minutes in a water bath and filtered while hot. On cooling, the phenylsemicarbazone crystallizes; dilution with water may sometimes be necessary. The crystals are then separated and recrystallized from either alcohol or dilute alcohol.

Thiosemicarbazones are another type of semicarbazones useful for identification of carbonyl compounds. The reagent employed is thiosemicarbazide ($\text{H}_2\text{N}\cdot\text{NH}\cdot\text{CS}\cdot\text{NH}_2$), a white crystalline substance m. $181^\circ\text{--}183^\circ$, sparingly soluble in cold water, more readily soluble in hot water, and only slightly soluble in alcohol.

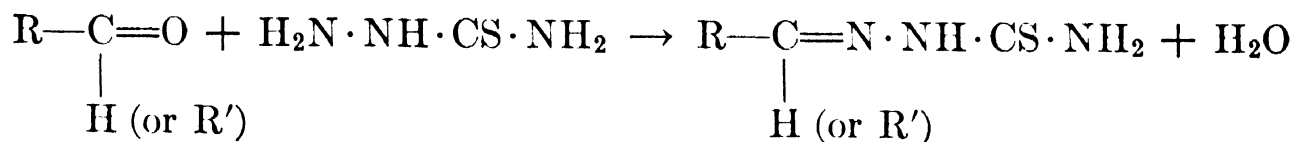

The thiosemicarbazones may be prepared as follows:

A strong solution of thiosemicarbazide in water is mixed with the aldehyde or ketone dissolved in alcohol. The mixture is then heated. On cooling, the thiosemicarbazone crystallizes. After the crystals are separated, they can be recrystallized from dilute alcohol or water.

Thiosemicarbazones have the distinctive property of forming insoluble compounds of the type

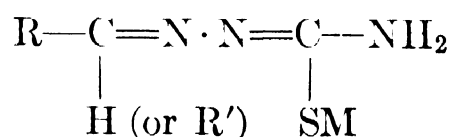

where M is a monovalent metal. The metal may be silver, copper, or mercury.

For the separation of carbonyl compounds from mixtures, the precipitation of the *silver compounds* has been proposed by Neuberg and Niemann.⁶⁰ The fact that the amount of silver can readily be determined permits the collection of additional information about the molecular weight equivalent of the carbonyl compounds under investigation.

For the preparation of the silver compound, an alcoholic solution of the thiosemicarbazone (freed of thiosemicarbazide by filtration) is treated with silver nitrate solution. The amorphous precipitate is then filtered, washed, and dried in a vacuum desiccator protected from light.

The aldehyde or ketone may be regenerated by treatment of the thiosemicarbazone or its silver compound with mineral acid.

In the preparation of semicarbazones and thiosemicarbazones it is possible that a semicarbazido-semicarbazone or a thiosemicarbazido-thiosemicarbazone may be formed in a greater amount than the monosemicarbazone. A typical example is the reaction with umbellulone investigated by Gillam and West.⁶¹

Among other substituted semicarbazides and similar reagents serving for the characterization of carbonyl compounds the following have been suggested:

4-Substituted semicarbazides. (R. Barré and L. Piché. *Can. J. Research* **19B** (1941), 158. *Chem. Abstracts* **35** (1941), 7380. *Can. J. Research* **20B** (1942), 17. *Chem. Abstracts* **36** (1942), 2530.)

o-, *m*-, and *p*-Tolyl semicarbazide. (P. P. T. Sah et al. *Science Repts. Natl. Tsing Hua Univ.* **2** (1933), 1. *Chem. Abstracts* **27** (1933), 4222. *J. Chinese Chem. Soc.* **2** (1934), 167. *Chem. Abstracts* **29** (1935), 465. *J. Chinese Chem. Soc.* **3** (1935), 246. *Chem. Abstracts* **29** (1935), 7298. *J. Chinese Chem. Soc.* **4** (1936), 187. *Chem. Abstracts* **31** (1937), 655.)

2,4-Dinitrophenyl semicarbazide. (J. L. McVeigh and J. D. Rose. *J. Chem. Soc.* (1945), 713. *Chem. Abstracts* **40** (1946), 554.)

Dinitrophenyl semicarbazide. (P. P. T. Sah and P. C. Tao. *J. Chinese Chem. Soc.* **4** (1936), 506. *Chem. Abstracts* **31** (1937), 4267.)

α -Naphthyl semicarbazide. (P. P. T. Sah and S. H. Chiang. *J. Chinese Chem. Soc.* **4** (1936), 496. *Chem. Abstracts* **31** (1937), 4266.)

β -Naphthyl semicarbazide. (P. P. T. Sah and P. C. Tao. *J. Chinese Chem. Soc.* **4** (1936), 501.)

p-Xenyl semicarbazide. (P. P. T. Sah and I. S. Kao. *Rec. trav. chim.* **58** (1939), 459. *Chem. Abstracts* **33** (1939), 5773.)

Semioxamazide. (L. G. Radcliffe. *Perfumery Essential Oil Record* **10** (1919), 39. Cf. also F. J. Wilson and E. C. Pickering, *J. Chem. Soc.* **123** (1923), 394; **125** (1924), 1152.)

5-Phenylsemioxamazide. (P. P. T. Sah and W.-P. Han. *Science Repts. Natl. Tsing Hua Univ.* **3** (1936), 469. *Chem. Abstracts* **31** (1937), 3825.)

(c) *Reactions with Sodium (or Potassium) Cyanide and Ammonium Carbonate (to Form Hydantoin Derivatives)*.—Henze and Speer⁶² prepared hydantoins from carbonyl compounds for identification purposes, using readily available and inexpensive reagents. The reaction is carried out with a dilute alcoholic solution of sodium (or potassium) cyanide and ammonium carbonate, which, on warming with carbonyl compounds, generally yield solid hydantoins with well-defined melting points:

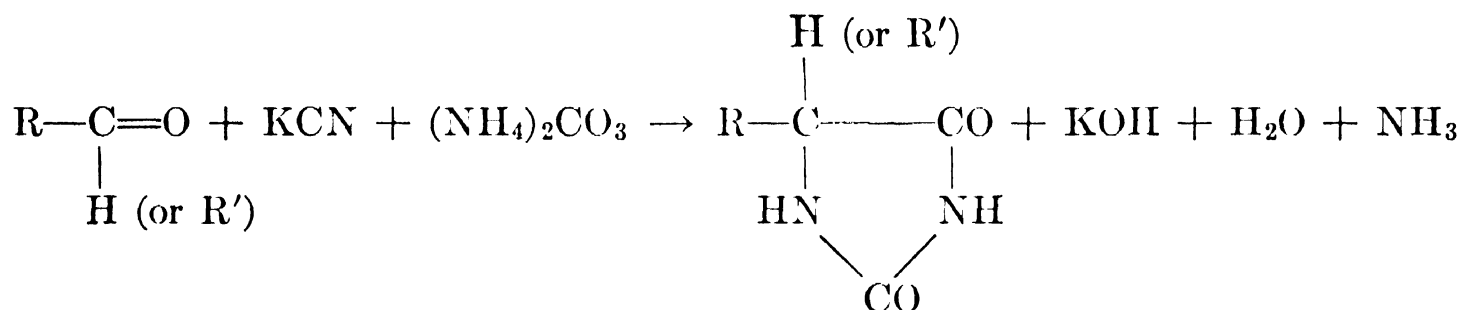

These hydantoins may be prepared as follows:

In 50 cc. of 50% alcohol 0.02 mol of the carbonyl compound is dissolved, and 9.1 g. (0.08 mol) of ammonium carbonate and 2.6 g. (0.04 mol) of potassium cyanate added. This mixture is warmed in a flask equipped with a condenser at a temperature of 58°–60° for about 2 hr.; the solution is then concentrated to about two-thirds of the initial volume and chilled in an ice bath. The hydantoins will then usually separate.

In general the hydantoins are very pure even when separated from the reaction mixture. They may be recrystallized, however, from aqueous alcohol solutions. In special cases, the hydantoins do not separate from the reaction mixture: for example, hydantoin derivatives of low molecular weight carbonyl compounds, which are quite soluble in water. In such cases, acidification with hydrochloric acid, to induce crystallization, is recommended. Great care must be taken, however, since hydrogen cyanide may be set free!

¹ *Z. anal. Chem.* **77** (1929), 241, 321. *Z. angew. Chem.* **42** (1929), 46. Cf. Neuberg, *ibid.*, 48; Mayer, *ibid.*

² *Ber.* **27** (1894), 352.

³ *Ibid.* **31** (1898), 3329.

⁴ "The Systematic Identification of Organic Compounds," 3d Ed., John Wiley, New York (1948), 202.

⁵ "The Systematic Identification of Organic Compounds," 3d Ed., John Wiley, New York (1948), 171.

⁶ *J. Am. Chem. Soc.* **52** (1930), 2955.

- ⁷ *Liebigs Ann.* **324** (1902), 315.
- ⁸ *Sci. Rept. Natl. Tsing Hua Univ.* **2** (1933), 8.
- ⁹ *J. Chem. Soc.* **125** (1924), 1328.
- ¹⁰ *Ber.* **35** (1902), 959, 2626.
- ¹¹ *Rec. trav. chim.* **15** (1896), 225.
- ¹² *Liebigs Ann.* **366** (1909), 277.
- ¹³ *Ibid.* **190** (1878), 175.
- ¹⁴ *Ber.* **39** (1906), 3584.
- ¹⁵ *J. Biol. Chem.* **114** (1936), 544.
- ¹⁶ *Nord. Kemikermøde* **5** (1939), 223. *Chem. Abstracts* **38** (1944), 5752.
- ¹⁷ *Ibid.*
- ¹⁸ *Liebigs Ann.* **418** (1919), 127.
- ¹⁹ *J. Biol. Chem.* **114** (1936), 539.
- ²⁰ *Nord. Kemikermøde* **5** (1939), 233. *Chem. Abstracts* **38** (1944), 5752. Veibel, *Acta Chem. Scand.* **1** (1947), 54. *Chem. Abstracts* **42** (1948), 1234. Veibel, Blaaberg, and Stevens, *Dansk Tid. Farm.* **14** (1940), 184. *Chem. Abstracts* **36** (1942), 2495.
- ²¹ *Liebigs Ann.* **232** (1886), 237. Lei, Sah and Kao, *Science Repts. Natl. Tsing Hua Univ. Ser. A*, **2** (1934), 335. *Chem. Abstracts* **29** (1935), 465.
- ²² *Ber.* **27** (1894), 1919.
- ²³ *J. Am. Chem. Soc.* **57** (1937), 706.
- ²⁴ *Ber.* **22** (1889), 2801.
- ²⁵ *Rec. trav. chim.* **24** (1905), 36, 37.
- ²⁶ *Ber.* **35** (1902), 2004.
- ²⁷ *Sci. Rept. Natl. Tsing Hua Univ.* **1** (1932), 261.
- ²⁸ *Ibid.* **3** (1936), 403, 409.
- ²⁹ *Ibid.* **2** (1933), 1.
- ³⁰ *Gazz. chim. ital.* **24**, [1] (1894), 113. Bredereck and Fritzsche, *Ber.* **70B** (1937), 802. *Chem. Abstracts* **31** (1937), 4656.
- ³¹ *Ber.* **27** (1894), 3106.
- ³² *J. Pharm. Soc. Japan* **55** (1935), 880. *British Chem. Abstracts Sect. A*, II (1937), 411.
- ³³ *Rec. trav. chim.* **59** (1940), 349.
- ³⁴ *Sci. Rept. Natl. Tsing Hua Univ.* **3** (1936), 555.
- ³⁵ *J. Chinese Chem. Soc.* **4** (1936), 69.
- ³⁶ *Sci. Rept. Natl. Tsing Hua Univ.* **3** (1935), 279.
- ³⁷ *Ibid.* **2** (1934), 359.
- ³⁸ *Ibid.* **3** (1936), 443.
- ³⁹ *Ibid.* **2** (1934), 352.
- ⁴⁰ *Ibid.* **3** (1936), 461.
- ⁴¹ *Rec. trav. chim.* **59** (1940), 241.
- ⁴² *J. Am. Chem. Soc.* **57** (1935), 758. Meng and Sah, *Science Repts. Natl. Tsing Hua Univ. Ser. A*, **2** (1934), 347. *Chem. Abstracts* **29** (1935), 465.
- ⁴³ *Sci. Rept. Natl. Tsing Hua Univ.* **3** (1936), 461. Meng and Sah, *Science Repts. Natl. Tsing Hua Univ. Ser. A*, **2** (1934), 347. *Chem. Abstracts* **29** (1935), 465.
- ⁴⁴ *J. Chinese Chem. Soc.* **3** (1935), 251.
- ⁴⁵ *Rec. trav. chim.* **51** (1932), 302. Cameron and Storrie, *J. Chem. Soc.* (1934), 1330. Davies, Storrie and Tucker, *ibid.* (1931), 624.
- ⁴⁶ *J. Chinese Chem. Soc.* **2** (1934), 40.
- ⁴⁷ *Ibid.* **4** (1936), 63.
- ⁴⁸ *Sci. Rept. Natl. Tsing Hua Univ.* **3** (1936), 469.
- ⁴⁹ *J. Am. Chem. Soc.* **63** (1941), 120.
- ⁵⁰ *Helv. Chim. Acta* **19** (1936), 1095.
- ⁵¹ Girard and Sandulesco, French Patent No. 767,464, July 18, 1934.
- ⁵² *Rev. chim. ind.* **48** (1939), 226.
- ⁵³ *Riechstoff Ind. Kosmet.* **12** (1937), 161. *Ind. Parfumerie* **3** (1948), 75.
- ⁵⁴ "Organic Syntheses," Coll. Vol. II, John Wiley, New York, p. 85.
- ⁵⁵ *J. Biol. Chem.* **140** (1941), 21.
- ⁵⁶ *Bull. soc. chim.* (1946), 172. *Chem. Abstracts* **40** (1946), 6083.
- ⁵⁷ *J. Org. Chem.* **6** (1941), 596.

⁵⁸ *J. Roy. Tech. Coll. Glasgow* **2** (1929), 52.

⁵⁹ Private communication by Dr. A. J. Haagen-Smit, California Institute of Technology, Pasadena, Calif.

⁶⁰ *Ber.* **35** (1902), 2049.

⁶¹ *J. Chem. Soc.* (1945), 95.

⁶² *J. Am. Chem. Soc.* **64** (1942), 522.

IV. PHENOLS AND PHENOL ETHERS

With a few exceptions, phenols are *very weak acids*. Nevertheless, they are sufficiently acidic to be dissolved by aqueous sodium hydroxide, forming phenolates. This fact offers a convenient method for their isolation from water insoluble substances. The phenol can be easily regenerated from the water soluble phenolate by acidification.

Phenols are weaker in their acidic property than carbonic acid. They do not dissolve in sodium carbonate solution, and can be regenerated, by the action of carbon dioxide, from an aqueous alkali solution. By this reaction phenols may be distinguished from carboxylic acids.

The phenol ethers are very stable neutral compounds, sparingly soluble in water, and usually indifferent toward alkalis. When phenol ethers are heated with hydrobromic or hydroiodic acid they are generally cleaved, and the phenol may be regenerated. Phenol ethers do not undergo the reactions typical for phenols, for which reason their identification is accomplished either through their conversion into phenols or through the reaction products typical for aromatic ethers. Phenol ethers can be identified by means of the crystalline derivatives which result from reactions such as bromination, nitration, or oxidation.

Another reagent often employed for the characterization of phenol ethers is *chlorosulfonic acid*.¹

Chlorosulfonic acid reacts readily with phenol ethers at low temperature, yielding *sulfonyl chlorides*, which when heated with ammonia or ammonium carbonate yield *sulfonamides*. The latter are easily purified and may serve well as derivatives characteristic for the phenol ether used in the reaction:

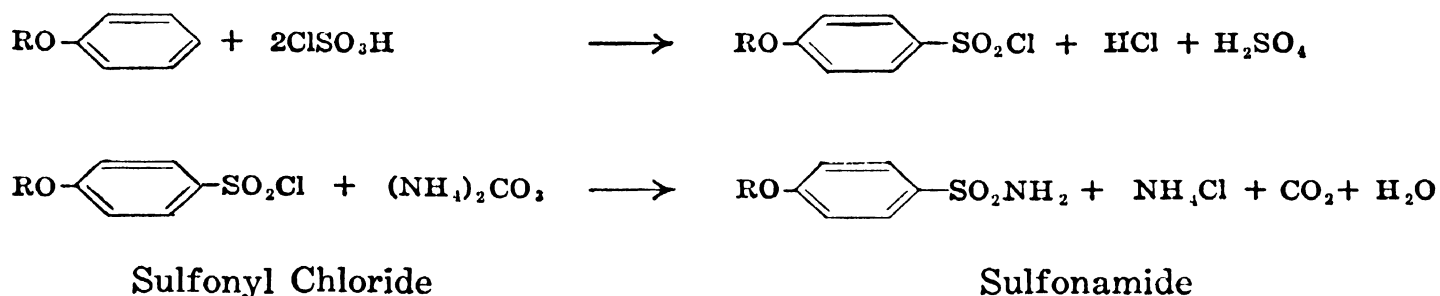

Chlorosulfonic acid as a reagent has the disadvantage of being very corrosive, for which reason other reagents are often to be preferred.

Many phenols and phenol ethers form characteristic solid reaction products with well-defined melting points when reacted upon by *picric acid*² or *1,3,5-trinitrobenzene*. Both reactions and reaction products have been discussed in the monograph on "Hydrocarbons," p. 788. Characteristic addition products may also be formed with *mercuric acetate*. These derivatives may serve for the purpose of identification (Manchot et al.³).

Certain phenols can be identified readily by products resulting from reactions which serve also for the preparation of derivatives of many other groups of compounds: for example, nitration, reaction with maleic anhydride and particularly bromination. The reaction between phenols and *bromine* is a substitution reaction (see p. 780) in the course of which hydrobromic acid is evolved. The phenol group increases the velocity of the bromine substitution. The resulting crystalline bromides

are usually sparingly soluble and therefore easily separable. For many phenols the bromides prove to be characteristic derivatives useful for identification purposes.

The well-known color test, based on the reaction of phenols with ferric chloride in dilute aqueous solution, is often employed to indicate the presence of phenols. The resulting iron compounds are in most cases highly colored. Enol compounds, as well as certain α -hydroxy acids, and some aliphatic acids, may also give a positive color test, however.

The phenolic group undergoes many reactions analogous to those of the alcohol group, yielding the same type of reaction products useful for identification purposes. Such are reactions with acetic anhydride (used mostly in quantitative determination), benzoyl chloride, *p*-nitrobenzoyl chloride, 3,5-dinitrobenzoyl chloride,⁴ phenylisocyanate,⁵ *p*-iodophenylisocyanate, α -naphthylisocyanate. Several of the common phenols may be condensed with phthalic anhydride, to produce phthaleins.

As with tertiary alcohols, the reactions with phenols often take place more readily in the presence of an organic base such as pyridine.

Diphenylurethanes (Diphenylcarbammates).—Diphenylcarbonyl chloride can also be employed as reagent in the preparation of phenol, as well as alcohol, derivatives (see p. 797), but it seems to be more reactive toward the phenolic group than toward the alcoholic group. In the presence of pyridine, phenols and diphenylcarbonyl chloride form diphenylurethanes (also referred to as diphenylcarbonyl esters, or diphenylcarbammates):

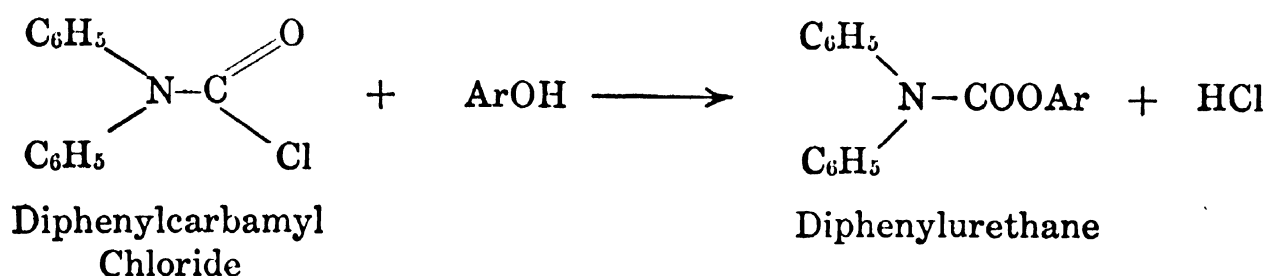

Diphenylcarbonyl chloride is a white to pale yellow crystalline solid, melting at 85°–86°. It is soluble in alcohol, with which it will react on standing, to form diphenylurethanes.

The preparation of diphenylurethanes may be carried out as follows:

About 1 g. of phenol is dissolved in 5 cc. of pyridine. Slightly less than 1 mol equivalent of diphenylcarbonyl chloride is added. The mixture is refluxed for about 30 min. and then poured into cold water. The crystals, which sometimes consist of a resinous mass, are then separated from the water and recrystallized from a suitable solvent, such as alcohol, petroleum ether, carbon tetrachloride, or benzene.

***p*-Toluene Sulfonic Esters (*p*-Toluene Sulfonates).**—Another reagent employed for the preparation of derivatives of phenols, and in special cases of alcohols (see p. 797) is *p*-toluenesulfonyl chloride.

p-Toluenesulfonyl chloride is a white crystalline powder, melting at 66°–67°, sparingly soluble in water, soluble in alcohol and ether, very soluble in benzene. Hopkin and Williams⁶ suggested the following procedure for the preparation of *p*-toluene sulfonic esters (*p*-toluene sulfonates):

Two grams of the phenol are suspended or dissolved in 5 cc. of pyridine, and 4 g. of *p*-toluenesulfonyl chloride are added. The mixture is heated on a water bath for about 15 min., then poured into 50 cc. of cold water and stirred until a solid crystalline mass is formed. The crystals are washed with cold dilute sodium hydroxide and cold water, and recrystallized from ethyl alcohol or methyl alcohol.

Aryl Oxyacetic Acids.—An excellent reagent for obtaining characteristic derivatives from phenols is chloroacetic acid. It reacts with phenols yielding aryl oxyacetic acids, which have well-defined melting points.

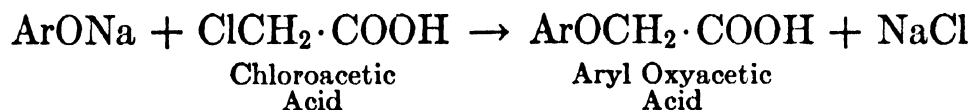

The aryl oxyacetic acids are easily prepared and have the advantage of being acids, which can be dissolved in dilute alcohol and titrated with standard alkali, thus making it possible to establish the molecular weight equivalent of the phenol being investigated. According to Koelsch,⁷ the aryl oxyacetic acids may be prepared as follows:

To a mixture of 1 g. of phenol and 3.5 cc. of 33% sodium hydroxide is added a solution of 2.5 cc. of 50% chloroacetic acid. If necessary a little water is added to dissolve the sodium phenolate. The vessel containing the solution is stoppered loosely and heated gently for 1 hr. on a water bath. After cooling, the solution is acidified with mineral acid (for example, hydrochloric acid), and extracted with ether. The ether layer is then washed once with water, and the aryl oxyacetic acid removed from the ether solution by further extracting the ether layer with sodium carbonate solution (25 cc. portions of 5% aqueous Na₂CO₃ solution). The sodium carbonate extract, containing the sodium salt of the aryl oxyacetic acid, is then acidified, yielding the free acid, which can be recrystallized from water.

***p*-Nitrobenzyl Ethers.**—*p*-Nitrobenzyl chloride, *p*-nitrobenzyl bromide, and *p*-nitrobenzyl iodide have been suggested as reagents to form characteristic derivatives of phenols. Of these reagents *p*-nitrobenzyl bromide is to be preferred because of its greater reactivity and its solubility in alcohol. *p*-Nitrobenzyl bromide with most phenols yields characteristic crystalline ethers having well-defined melting points valuable for the characterization of phenols.

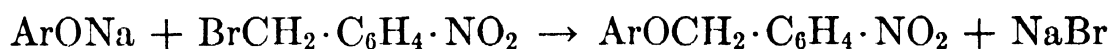

(This reagent is also useful for the characterization of many carboxylic acids, the reaction yielding *p*-nitrobenzyl esters, see p. 828.)

According to Reid, and Lyman and Reid⁸ the following procedure may be employed:

A mixture of 1 g. of the phenol in 1 cc. of 20% sodium hydroxide and 1 g. of reagent in 25 cc. of alcohol is refluxed for 1 hr. Five to 10 cc. of water are then added to dissolve any alkali bromide. Enough alkali is added to make the solution alkaline to litmus. After cooling the *p*-nitrobenzyl ether is separated and recrystallized from alcohol or a dilute alcohol solution.

A number of other reagents have been found to yield derivatives useful for the identification of phenols. Some of these reagents are:

- β -Naphthylisocyanate⁹
- p*-Xenylisocyanate¹⁰
- p*-Chlorobenzazide¹¹
- p*-Bromobenzazide¹²
- p*-Nitrobenzazide¹³
- 3,5-Dinitrobenzazide¹⁴
- 3,5-Dinitro-4-methylbenzazide¹⁵
- 2,4-Dinitrochlorobenzene¹⁶
- Benzene sulfonyl chloride¹⁷
- Aryl *p*-bromobenzene sulfonates¹⁸

o-Nitro-, *m*-nitro-, *o*-chloro-, *m*-chloro-, *p*-chloro-, *o*-bromo-, *m*-bromo- and *p*-bromo-benzoylazide ¹⁹
o-Nitrobenzazide ²⁰

- ¹ Huntress and Carten, *J. Am. Chem. Soc.* **62** (1940), 603.
- ² Cf. Baril and Megrđichian, *ibid.* **58** (1936), 1415.
- ³ *Liebigs Ann.* **399** (1913), 123; **417** (1918), 93; **420** (1920), 170; **421** (1920), 316, 330.
- ⁴ Brown and Kremer, *J. Am. Pharm. Assocn.* **11** (1922), 607. Phillips and Keenan, *J. Am. Chem. Soc.* **53** (1931), 1924.
- ⁵ McKinley, Nickels, and Sidhu, *Ind. Eng. Chem. Anal. Ed.* **16** (1944), 304.
- ⁶ "Organic Reagents for Organic Analysis," by Staff of Hopkin and Williams Research Laboratory, New York, Chemical Publishing Co. (1946).
- ⁷ *J. Am. Chem. Soc.* **53** (1931), 304.
- ⁸ *Ibid.* **39** (1917), 304; **42** (1920), 615.
- ⁹ Sah, *Rec. trav. chim.* **58** (1939), 453.
- ¹⁰ Morgan and Pettet, *J. Chem. Soc.* (1931), 1125. Van Gelderen, *Rec. trav. chim.* **52** (1933), 979.
- ¹¹ Kao, Fang, and Sah, *Science Repts. Natl. Tsing Hua Univ.* [A], **3** (1935), 109. *Chem. Abstracts* **29** (1935), 6173.
- ¹² Sah and Cheng, *Rec. trav. chim.* **58** (1939), 591. *Chem. Abstracts* **33** (1939), 6746.
- ¹³ Sah and Chiao, *Rec. trav. chim.* **58** (1939), 595. *Chem. Abstracts* **33** (1939), 6746.
- ¹⁴ Sah and Ma, *J. Chinese Chem. Soc.* **2** (1934), 229. *Chem. Abstracts* **29** (1935), 749.
- ¹⁵ Sah, *Rec. trav. chim.* **58** (1939), 582. *Chem. Abstracts* **33** (1939), 6746.
- ¹⁶ Bost and Nicholson, *J. Am. Chem. Soc.* **57** (1935), 7368.
- ¹⁷ Georgescu, *Ber.* **24** (1891), 416.
- ¹⁸ Sekera, *J. Am. Chem. Soc.* **55** (1933), 421.
- ¹⁹ Sah, Chiao, Chang, Wang, and Wang, *J. Chinese Chem. Soc.* **13** (1946), 22. *Chem. Abstracts* **42** (1948), 148.
- ²⁰ Sah and Yin, *Rec. trav. chim.* **59** (1940), 238. *Chem. Abstracts* **34** (1940), 5786.

V. ACIDS

Most organic acids are relatively weak acids; however, they are strong enough to displace the very weak carbonic acid from its salts (differing in this respect from phenols, see p. 823):

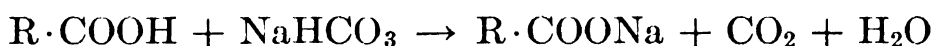
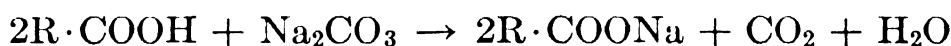

In the identification of organic acids the determination of the neutralization equivalent is generally of great help in establishing the molecular weight equivalent of an acid. *The neutralization equivalent* is the quantity of the compound (expressed in grams) required for the neutralization of 1 liter of normal alkali solution. For monobasic acids it is identical with *the number representing the molecular weight*; for polybasic acids it is the simple submultiple of this number:

$$\text{Neutralization equivalent} = \frac{1000 \times s}{a \times N}$$

s = weight of sample of the acid in grams;

a = volume of alkali in cc., used for neutralization;

N = normality of alkali.

The neutralization equivalent should not be confused with the acid number. (The acid number is the quantity of potassium hydroxide, expressed in milligrams, required to neutralize the acids in 1 g. of the sample.) (See Vol. I of this work, p. 264.)

Many *salts of acids* are well-crystallized solids, which may be useful for identification purposes (for example, calcium, barium, lead, zinc, mercury, and silver salts). The silver salts are often prepared, since they afford a means of identifying the acid by its melting point; they may also be employed to establish the molecular weight equivalent of the acid by gravimetric or volumetric determination of the amount of silver present in the salt.

The alkali salts are often prepared to isolate acids from other nonacidic substances present. Alkali salts are usually water soluble and may be separated from other non-soluble substances by extraction of the latter with organic solvents, for example, ether. The acids can then be regenerated from the aqueous layer by acidification with mineral acid.

Many acids may be identified by means of their *bromides, nitrosites, nitrosochlorides, maleic anhydride addition products, reduction products, or other derivatives* resulting from reactions which take place also with substances other than acids.

Some acids form easily identifiable degradation products which may be useful for the characterization of the acids. Such degradation products may be a hydrocarbon resulting from decarboxylation, or an anhydride resulting from dehydration.

Many acids form solid esters (see p. 792) which serve well as identification products. If the lower aliphatic esters are solids they may be useful for characterizing an acid. In most cases, however, it is necessary to prepare such esters as *p-nitrobenzyl, phenacyl,*

p-chlorophenacyl, *p*-bromophenacyl, or *p*-phenylphenacyl esters. These are best prepared by reacting the salt of the acids with the corresponding halide:

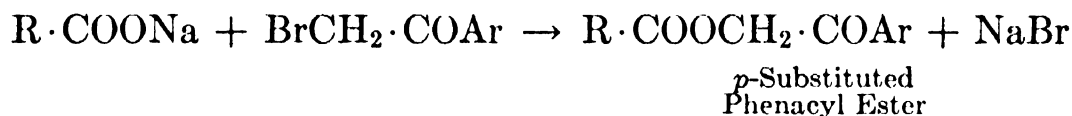
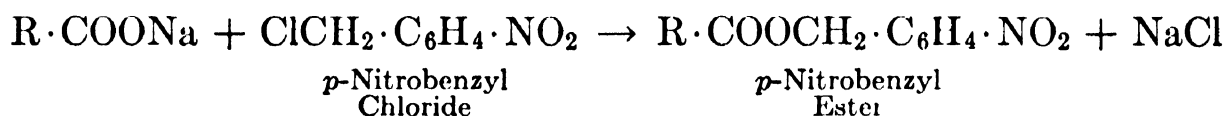

(Ar stands for the phenyl group or the *p*-substituted phenyl group)

The preparation of esters from alkali salts has the particular advantage that it does not require an anhydrous sample of the acid.

For the preparation of *p*-nitrobenzyl esters from *p*-nitrobenzyl chloride, see "Phenols," p. 825.

The preparation of all phenacyl esters and substituted phenacyl esters is similar. Some of the reagents used for the preparation of phenacyl esters are:

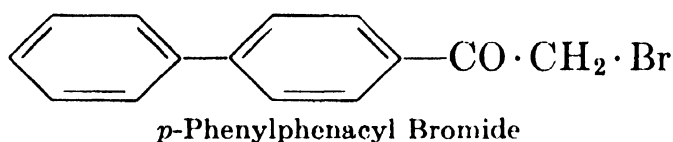
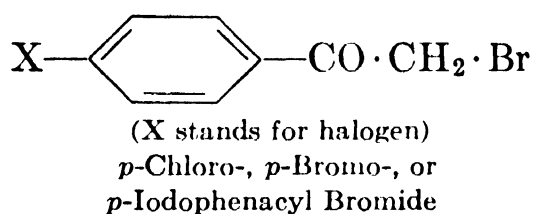
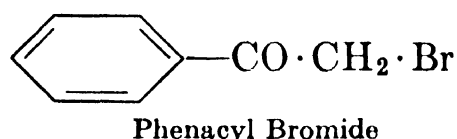

Most phenacyl halides have lachrymatory properties. *p*-Bromophenacyl bromide may possess a certain advantage as a reagent in that it has better keeping qualities.

The following general procedure may be employed for the preparation of all these phenacyl esters:

The sodium salt of the acid is prepared by neutralizing the aqueous solution of the acid (1 g. in 5 cc.) carefully with a 10% sodium hydroxide solution, until the solution is just acid to litmus. To the sodium salt in water, an alcoholic solution of the phenacyl bromide (or substitute phenacyl halide) (1 g. in 10 cc. of alcohol) is added. If the solution is not clear on heating, it will be necessary to add more alcohol. The mixture is then boiled for 1 hr., if a monobasic acid is being examined; for 2 hr., if the compound is dibasic; or for 3 hr., if tribasic. On cooling, the ester usually precipitates, and can be separated and recrystallized from alcohol or dilute alcohol.

Acyl chlorides (acid chlorides) may be useful in special cases as identification products. They may be prepared from acids by the action of phosphorus pentachloride or thionyl chloride.

The acyl chlorides, however, are often converted into the generally water insoluble *amides*, which frequently prove more satisfactory as derivatives.

The amides may be prepared by heating 1 g. of the acid with 5 cc. of thionyl chloride for 15 to 30 min. The reaction mixture is then poured into 15 cc. of a well-cooled, concentrated solution of ammonia. The precipitated amide can usually be recrystallized from dilute alcohol or water.

Amides such as *anilides*, *p-bromoanilides*, *p-toluidides* are often prepared as characteristic derivatives for the identification of acids.

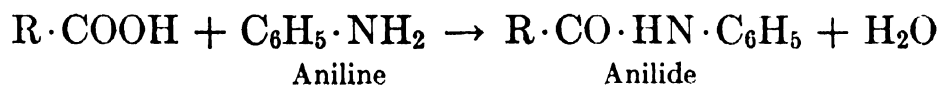

For the preparation of the anilides or toluidides, it may be advisable to convert the acid into the corresponding acyl chloride and then react it with aniline, *p*-bromoaniline, or toluidine.

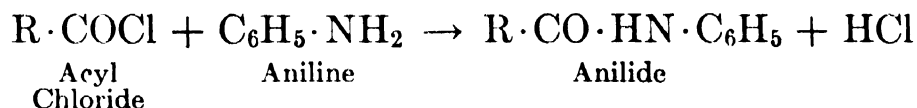

The following general procedure may be employed for the preparation of anilides or toluidides:

One gram of the acid or its sodium salt is placed into a small flask, mixed with the equimolar amount of thionyl chloride, and heated under a reflux condenser for about 30 min. After the mixture is cooled, more than the mol equivalent of the amine (1 to 2 g. of aniline, *p*-toluidine, or bromoaniline) is cautiously added, and the mixture is heated for about a half hour. In many instances it will be advisable to add a solvent such as benzene before heating (about 30 cc. for each g. of acyl chloride). The derivatives are usually soluble in benzene. If benzene has been added as a solvent, the benzene solution—after boiling and allowing to cool to room temperature—may be decanted into a separatory funnel and washed with water, dilute acid (to remove excess amine), then dilute alkali (to remove excess acid), and washed neutral with water. The benzene solution is dried and filtered and the solvent evaporated. The crystals are then recrystallized from dilute ethyl or methyl alcohol, or petroleum ether containing some benzene.

Benzylisothiourea hydrochloride (S-benzyl thiuronium chloride) is sometimes a very useful reagent for the preparation of derivatives of carboxylic acids (see "Alcohols," p. 797).

Dewey and Sperry¹ suggested the use of *p*-chlorobenzyl isothiourea hydrochloride (*p*-chlorobenzyl pseudothiuronium chloride) as a reagent to prepare *p*-chlorobenzyl isothiuronium salts of the organic acids, which are generally characteristic derivatives.

According to Dewey and Shasky² the identification of organic acids through the use of *p*-bromobenzyl isothiourea hydrobromide (*p*-bromobenzyl pseudothiuronium bromide, m. 213°) offers an advantage over the use of the *p*-chlorobenzyl isothiourea hydrochloride in that its salts do not readily undergo hydrolytic decomposition.

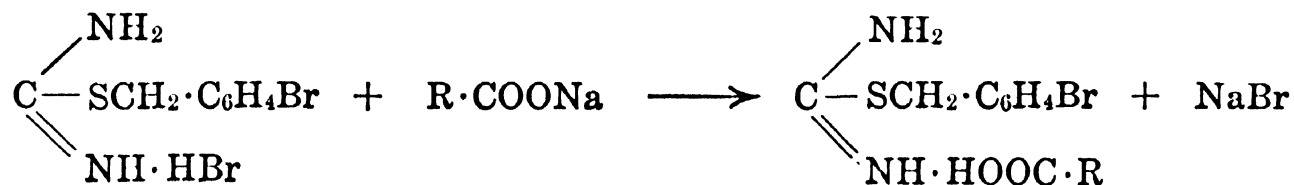

According to Dewey and Shasky the *p*-bromobenzyl isothiuronium compounds can be obtained by adding a hot alcoholic solution of the reagent to an aqueous solution of the sodium or potassium salt of the acid. The *p*-bromobenzyl isothiuronium compounds generally precipitate at once in a pure state. The crystals may be recrystallized from a suitable solvent (alcohol, for example).

The high molecular weight of the reagent and the low solubility of the derivative make it possible to obtain a large yield of the derivative from small amounts of the acid. The melting points of these derivatives are often too close to be of value where a mixture of acids is present.

Many acids may also be identified by their reaction with *benzylamine* to yield *N*-substituted benzylamides. This reaction is characteristic for the acyl group; esters will therefore give the same reaction (see "Esters," p. 832).

Many other reagents have been suggested by various investigators; among them are:

- o*-Bromo-*p*-toluidine ³
- 2,4,6-Tribromoaniline ³
- β -Naphthylamine ³
- 1-Bromo-2-naphthylamine ³
- α -Naphthylamine ⁴
- pp'*-Diaminodiphenylurethane ⁵
- o*-Phenylenediamine ⁶
- p*-Chlorophenacyl bromide ⁷
- p*-Bromophenacyl bromide ⁸
- p*-Iodophenacyl bromide ⁸
- p*-Phenylphenacyl bromide ⁹

¹ *J. Am. Chem. Soc.* **61** (1939), 3251.

² *Ibid.* **63** (1941), 3526.

³ Robertson, *J. Chem. Soc.* **115** (1919), 1210.

⁴ Robertson, *ibid.* **93** (1908), 1033.

⁵ Ralston and McCorkle, *J. Am. Chem. Soc.* **61** (1939), 1604.

⁶ Seka and Müller, *Monatsh.* **57** (1931), 97. Pool, Harwood and Ralston, *J. Am. Chem. Soc.* **59** (1937), 178.

⁷ Judefind and Reid, *J. Am. Chem. Soc.* **42** (1920), 1043.

⁸ Judefind and Reid, *ibid.* Hann, Reid and Jamieson, *ibid.* **52** (1930), 818. Cf. Powell, *ibid.* **53** (1931), 1172.

⁹ Drake and Bronitsky, *ibid.* **52** (1930), 3715.

VI. ESTERS

When acted upon by alkali, esters usually are easily converted into the corresponding alcohols and alkali salts of the acids. This hydrolysis is called *saponification*:

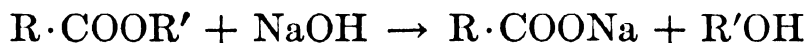

Certain esters can be identified easily by saponifying the ester and by identifying the corresponding acid and alcohol separately.

For the quantitative determination of esters by saponification see Vol. I of this work, p. 265.

Like the neutralization equivalent of an acid, the *saponification equivalent* of an ester may afford an additional means of determining its molecular weight equivalent. The saponification equivalent of an ester is the quantity (expressed in grams) of the compound required for the neutralization of 1 liter of normal alkali solution. (The saponification equivalent should not be confused with the ester number and the saponification number. The ester number is the quantity of potassium hydroxide, expressed in milligrams, required to saponify the ester in 1 g. of the sample. The saponification number is the sum of the ester number and the acid number.)

$$\text{Saponification equivalent} = \frac{1000 \times s}{a \times N}$$

s = weight of sample in grams;

a = volume of alkali in cc., used for saponification;

N = normality of alkali.

Esters can undergo alcoholysis and ammonolysis as well as hydrolysis. The alcoholysis is also known as ester interchange (see p. 792). It takes place extremely slowly in the absence of a catalyst, but rather rapidly, when even traces of certain substances—sodium alcoholate, for example—are present. However, the reaction reaches a certain equilibrium and therefore does not go to completion.

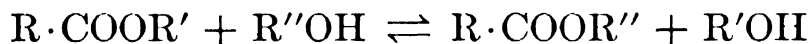

To effect completion, special experimental conditions are required; for instance, the presence of a very large excess of the alcohol ($\text{R}''\text{OH}$) or the removal of one of the newly formed compounds, for example, the alcohol ($\text{R}'\text{OH}$), is necessary. Ester interchange is useful for the identification of an ester only in very special cases. It may prove of value, for example, where a "new" ester has more characteristic properties than the original ester, i.e., when the new ester is a solid with well-defined melting point, or can be more easily identified than the original ester.

Ammonolysis (reaction with ammonia) does not appear to be a practical means of identification. However, *aminolysis* (the reaction with amines) has proved very valuable in the direct identification of the acyl group of esters. The "indirect" method of identifying the ester by its saponification products (i.e., isolating the acid or acid salt of the ester and converting the former into a characteristic derivative) is often time-consuming and may be unsuccessful. Recently several methods have been developed whereby the acyl group of an ester (or acid) can be identified directly.

To obtain a derivative directly from an ester, Koelsch and Tenenbaum¹ and Hardy² have recommended adding the ester to the bromomagnesium salt of an aryl-

amine thus yielding the corresponding arylamide. Buehler and Mackenzie³ identified many esters by direct aminolysis with benzylamine, forming N-substituted benzylamides:

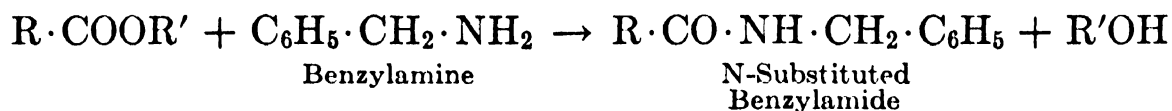

Dermer and King⁴ have experimented with several of the common high boiling organic bases as reagents for aminolysis of esters. For this purpose they investigated benzylamine, dibenzylamine, cyclohexylamine, dicyclohexylamine, ethylenediamine, and phenyl hydrazine. The value of the latter as reagent for identification of organic acids was also investigated by Stempel and Schaffel.⁵

Benzylamine proved to be the best reagent. Dermer and King have developed a method which permits identification of many esters as well as free acids. The acyl compounds are converted into crystalline N-substituted benzylamides by refluxing the ester (or acid) to be tested with benzylamine, using a salt (ammonium chloride) as a catalyst.

This method proved effective in the identification of aromatic, hydroxy, alkoxy, polybasic acids and their respective esters.

Esters of keto acids or polynitro aromatic acids or halogenated aliphatic acids do not, in this reaction, yield satisfactory derivatives.

The esters of higher alcohols sometimes react very slowly, and it may be necessary to submit them to a longer period of heating than is necessary with other esters, or to subject them to a preliminary methanolysis in order to produce methyl esters, which have a comparatively high reactivity.

The following general method for the identification of the acyl group has been suggested by Dermer and King:

One cc. (or 1 g.) of the ester (or acid) is added to 3 cc. of benzylamine together with 0.1 g. of ammonium chloride. The mixture is refluxed for an hour. On cooling, the crystalline amide usually precipitates. If this is not the case acidification with hydrochloric acid will often induce crystallization. If too much unreacted ester remains, keeping the amide in solution, the ester may be removed by boiling with water. The separated crystals are washed with water to remove excess amine, then washed with petroleum ether to remove other organic impurities, and finally recrystallized from a suitable solvent—for example, aqueous acetone or alcohol.

¹ *J. Am. Chem. Soc.* **55** (1933), 3049.

² *J. Chem. Soc.* (1936), 398.

³ *J. Am. Chem. Soc.* **59** (1937), 421.

⁴ *J. Org. Chem.* **8** (1943), 168.

⁵ *J. Am. Chem. Soc.* **64** (1942), 470.

VII. LACTONES AND ANHYDRIDES

No specific tests have been developed for the identification of lactones and anhydrides. These compounds generally can be hydrolyzed, however, and the resulting acid (or acid salt) may be further identified by its characteristic derivatives. A saponification equivalent can be determined for many members of the lactone and anhydride groups, and the molecular weight equivalent of the substance under examination thus established. The saponification of lactones generally requires heating; a somewhat stronger solution of alkali than is used for esters must generally be employed.

Many lactones can be identified by the reaction products resulting from bromination, hydrogen halide addition, nitration, sodium bisulfite addition, etc. The reader is referred to the individual monographs on the Lactones, Coumarins and Coumarons for more detailed information concerning separation and identification.

VIII. OTHER CONSTITUENTS

Oxides, furan derivatives, cyanides, amino and imino compounds, and sulfides will not be discussed here in detail, since compounds of these types rarely occur in essential oils, or only in comparatively small amounts.

The reader is referred to the discussion of individual compounds in the preceding monographs, or to other, more detailed, literature.

INDEX

(Numbers in italics indicate principal entries)

- Acetaldehyde**, 308, 309, 332, 807
Aceteugenol, 518
Acetic acid, 201, 375, 377, 378, 379, 407, 559, 561, 565, 618, 620, 621, 623, 624, 626, 628, 630, 632, 794
"Acetic ether," 618
Acetone, 170, 176, 259, 332, 341, 373, 382, 384, 403, 458, 480
Acetophenone, 474
p-Acetylanisole, 478
Acetylbenzene, 474
Acetylugenol, 100, 518
2-Acetyl-1-isopropylcyclopropanecarboxylic acid, 441
1-Acetyl-2-methoxy-4-allylbenzene, 518
o-Acetylphenol, 477
p-Acetyltoluene, 476, 800
Acid azides, 774, 827
Acid chlorides, 828
Acid number, 827
Acids, 557
 aliphatic, 560
 dibasic, 592
 hydroxy, 593
 saturated, 560
 unsaturated, 583
 aromatic, 596
 fatty, 559
 miscellaneous, 606
 of doubtful constitution, 612
Acyl chlorides, 792, 828, 829
Acyl hydrazine, 811, 813
Agropyrene, 16
Alant-camphor, 691, 692
Alantolactone, 691, 767
Alcohols, 139, 754
Alcohols—dehydration, 791
 aliphatic, 141
 saturated, 141
 terpene, 166
 unsaturated, 158
 aromatic, 290
 miscellaneous, 299
 sesquiterpene, 258, 755, 760
 aliphatic, 258
 bicyclic, 263, 755
 monocyclic, 261, 755
 tricyclic, 280, 759
 of doubtful constitution, 281
 terpene, 754
 bicyclic, 229
 cyclic, 184
 monocyclic, 184
 tricyclic, 257
Alcoholysis, 793, 831
Aldehydes, 303, 804
 aliphatic, 305
 saturated, 307
 terpene, 326
 unsaturated, 318
 aromatic, 350
 heterocyclic, 367
 terpene, cyclic, 342
Aldol condensation, 804
Aldoximes, 810
Alkali salts, 827
Alkali xanthates, 802
2-Alkyl-(5,6)-benzocinchoninic acid, 806
2-Alkyl-(5,6)-benzoquinoline-4-carboxylic acid, 806
 α -Alkyl (or aryl)- β -naphthocinchoninic acid, 806
 α -Alkyl (or aryl)- β -naphthoquinoline, 806
Allicin, 733
Allophanates, 801
Allylaldehyde, 807
p-Allylanisole, 506
Allyl cyanide, 723, 734, 736
4-Allylguaiacol, 516
Allyl isothiocyanate, 734
Allyl mustard oil, 723, 734
p-Allylphenol, 505
Allylpropyl disulfide, 731
Allylpyrocatechol, 513, 528
Allylpyrocatecholmethylene ether, 526
Allylsulfonyl allyl sulfide, 733
Allyltetramethoxybenzene, 541
Allylthiocyanate, 734
Allylthiourea, 735
Allylthiourethane, 736
Allyltrimethoxybenzene, 540
4-Allylveratrole, 519
Ambrettolic acid, 595, 689
Ambrettolide, 595, 662, 689
Amides, 828
p-Aminobenzoic acid, 733
o-Aminobenzoic acid methyl ether, 651
Amino compounds, 725, 833
 α -Aminoguanidine, 811, 813
Aminolysis, 831
Ammonia, 721, 804
Ammonolysis, 831
n-Amyl alcohol, 146
Amyl ethyl ketone, 376
n-Amyl methyl carbinol, 150
n-Amyl methyl ketone, 375
Amyl nitrite, 782
l-n-Amylvinylcarbinol, 161

- Amyrol, 755
 Androl, 165
 Androstenol, 300
 Anethole, 358, 507, 508
 Anethole glycol, 511
 Anethole glycol ethers, 511
 Angelica acid, 584
 Angelic acid, 584, 585
 Angelicin, 660, 662, 686
 Angustione, 484, 485
 Anhydrides, 613, 833
 Anilides, 829
 Aniline, 829
p-Anisaldehyde, 358, 509, 510, 511, 513, 807
 "Anise camphor," 508
 Anisic acid, 480, 510, 511
p-Anisic acid, 358, 359, 360, 507, 509, 600
 Anisketone, 479, 511
 Anisoïn, 510
 Anisylicyanate, 799
p-Anisyl methyl ketone, 478
p-Anol, 512
p-Anol prenyl ether, 512
 Anthranilic acid methyl ester, 651, 653
 Anthraquinone, 790
 Antimonous acid, 794
 Antimony trichloride, 781, 790
 Antimony trihalides, 790
 Apioaldehyde, 538
 Apiole, 537
 Apioic acid, 538
 Araliene, 750
 Aromadendrene, 110, 129, 774
 Aromadendrene glycol, 111
 Arsenous acid, 794
 Arsenous anhydride, 794
 Artemisal, 318
 Artemisia ketone, 386
 Artemisol, 754
 Aryl *p*-bromobenzene sulfonates, 825
 Aryl oxyacetic acid, 825
 Aryl sulfonic acid, 788
 Asaronaldehyde, 366
 Asarone, 535
 Asaronic acid, 536, 537
 Asarylaldehyde, 366, 536
 Ascaridole, 715
 Ascaridole glycol, 716
 Ascaridole glycol anhydride, 716
 Aschan method, 777
 Atlantone, 448
 Atractylol, 755
 "Aubépine," 358
 Auraptene, 659, 672
 Auraptene hydrate, 674
cis-Auraptenic acid, 673
 Australol, 499
 Ayapanin, 667
 Azones, 817
 Azulenes, 127, 128, 263, 279, 281, 457, 762, 789, 790
 Baeckeol, 545
 Beckmann mixture, 775
 Benihinol, 754
 Benihiol, 754
 Benzaldehyde, 291, 351, 355, 721, 808
 Benzazides, substituted, 800
 1-Benzazole, 725
 Benzene sulfonyl chloride, 825
 Benzoates—preparation, 796
 Benzoic acid, 290, 291, 292, 293, 351, 354, 355, 475, 596, 636, 639
 Benzoic acid benzyl ester, 639
 Benzoic acid ethyl ester, 637
 Benzoic acid methyl ester, 636
 Benzoic anhydride, 794
 Benzoic esters, 796
 Benzopyrrole, 725
 Benzoylation, 796
 Benzoyl chlorides, 796, 824
 Benzylacetaldehyde, 356
 Benzyl acetate, 635
 Benzyl alcohol, 290, 635, 639, 649, 792
 Benzylamine, 830, 832
 Benzyl benzoate, 639
 Benzylcarbinol, 292
 Benzyl cinnamate, 649
 Benzyl cyanide, 723
 Benzyl-2-furylacetylene, 701
 Benzyl isothiocyanate, 740
 Benzyl isothiurea hydrochloride, 798, 829
 Benzyl mustard oil, 740
 1-Benzyl-1-phenylhydrazine, 813
 S-Benzylthiuronium chloride, 797, 798, 829
 S-Benzylthiuronium derivatives, 797
 "Bergamot camphor," 680
 Bergamottin, 676, 685
 Bergaptene, 660, 662, 666, 673, 679, 680, 685
 "Bergaptin," 685
 Bergaptol, 660, 678, 685, 686
 Bergaptol geranyl ether, 685
 Bergaptol isoamylene ether, 684
 Bertram-Walbaum mixture, 777
 Betel phenol, 514
 Betulene, 264, 750
 Betulenene, 264, 750
 Betulenol, 264, 750
 Betulenolic acid, 264
 Betulenols, 264
 Betulol, 264
 Biacetyl, 379
 Bisabolene, 84, 88, 96, 449, 775, 778
 1,1'-Bismenthone, 397
 Boiling point, 1
 Borates—preparation, 793
 Boric acid, 793, 794
 Boric anhydride, 793
 Boric esters, 793
 "Borneo-camphor," 239, 429
 Borneol, 49, 55, 66, 67, 69, 77, 79, 230, 238, 239, 246, 247, 429, 430, 432, 434, 627, 628, 777, 799
 Borneol esters, 430
 Borneol-isoborneol series, 239
 Bornyl acetate, 240, 242, 561, 628
 Bornyl alcohol, 239
 Bornyl chloride, 66, 70
 Bornylene, 77, 779, 784
 Bornyl formate, 627

- Bornyl isovalerate, 631
 Bornyval, 631
 "Bourbonal," 364
 "Brevifolin," 543
 Bromides—preparation, 824
 Bromination, 823
 Bromine, 780
 Bromine substitution, 823
p-Bromoanilides, 829
p-Bromobenzazide, 800, 825
 Bromobenzhydrazides, 814
 Bromobenzoylazide, 800, 826
p-Bromobenzyl isothioureia hydrobromide, 829
p-Bromobenzyl pseudothiuronium bromide, 829
 1-Bromo-2-naphthylamine, 830
 Bromonorpinic acid, 78
p-Bromophenacyl bromide, 828
p-Bromophenacyl esters—preparation, 828
p-Bromophenylhydrazine hydrochloride, 813
o-Bromo-*p*-toluidine, 830
 Brucine salts, 794
 Buchucamphor, 542
 Bulnesol, 756
 Bupleurol, 166, 794
 Butanal, 305, 310
 Butanoic acid, 563
n-Butanol, 144
 γ -Butenyl isothiocyanate, 738
n-Butyl alcohol, 144, 792
n-Butylidene phthalide, 609, 693
 Butyl isothiocyanate, α -secondary, 737
l-Butyl mercaptan, 732
 Butyl mustard oil, secondary, 737
n-Butyl phthalide, 692, 695
 Butyl-propenyl disulfide, secondary, 732
n-Butyraldehyde, 144, 305, 310
n-Butyric acid, 144, 310, 559, 561, 563, 565, 572, 625
 Butyric anhydride, 794

 Cadalene, 81, 82, 94, 96, 112, 122, 124, 268, 271, 272, 275, 276, 280, 281, 748, 749, 755, 757, 776, 779, 790
 Cadalene picrate, 82
 Cadalene styphnate, 82
 Cadinene, 81, 87, 91, 96, 98, 271, 272, 273, 275, 282, 749, 753, 777, 778, 782, 784
 Cadinene dihydrochloride, 91, 92, 97, 122, 287
 Cadinene hydrochloride, 97
 Cadinol, 273, 276, 755, 758
 "Cajuputol," 708
 Calamene, 81, 112, 280, 776
 Calamenene, 283
 Calamenenol, 282
 "Calameone," 279
 Calameonic acid, 280
 Calamol, 540
 Calamonic acid, 540
 Calcium chloride addition products—preparation, 792
 Callitrol, 587

 Camerene, 753
 Camphane, 79, 434
 2-Camphanol, 239
 Camphene, 66, 240, 246, 247, 430, 436, 630, 774, 777, 778
 Camphene glycol, 69
 Camphene hydrate, 69, 241, 247, 776, 777
 Camphene hydrochloride, 778
 Camphenic acid, 69
 Camphenilol, 437
 Camphenilone, 67, 69, 436
 Camphenylic acid, 69
 α -Campholonic acid, 58
 Camphor, 55, 240, 242, 243, 246, 418, 429, 430, 445
 Camphor-carvone, 415
 Camphorene, 8, 125, 126, 778, 779
 α -Camphorene tetrahydrochloride, 8
 Camphoric acid, 434, 606
 Camphor oil, sesquiterpene, 96
 Camphor oil, sesquiterpene alcohols, 271
 Camphoronic acid, 434
 Cannizzaro reaction, 805
 Caparrapen, 750
 Caparrapiol, 750
n-Capric acid, 156, 316, 325, 571, 574, 575
 Capric aldehyde, 316
n-Caproaldehyde, 305, 312
n-Caproic acid, 148, 149, 312, 376, 569, 688
 Caproic aldehyde, 312
n-Caprylaldehyde, 306, 314
n-Caprylic acid, 314, 324, 571, 572, 575
 Caprylic aldehyde, 314
 Carbamates—preparation, 798
 Carbamic acid esters, 798
 Carbamylcarbamates, 801
 Carbamylhydrazine, 811, 818
 Carbamylurethanes—preparation, 801
 Carbanilates, 799
 Carbanilide, 799
 Carbon disulfide, 734
 Carboxy methylhydrazine, 813
 3-Carboxy-1-methyl-pyridinium *p*-toluene sulfonate hydrazide, 817
 Carboxy phenylhydrazine, 813
 Carene, 774, 778, 782, 787
 Δ^2 -Carene, 51
 Δ^3 -Carene, 32, 49, 775, 779, 784, 786
 Δ^4 -Carene, 32, 51, 775
l- Δ^3 -Caren-5,6-epoxide, 714
 "Carlina oxide," 701
 Carone, 447
 Caronic acid, 51, 448
 Carotene, 458
 Carotol, 763
 Carvacrol, 17, 415, 499, 501, 503
 Carvacromenthol, 505
 Carvenone, 199, 411
 Carveol, 25, 203
 Carvestrene, 32
 Carvol, 412
 Carvomenthol, 213, 411, 414
 Carvomenthone, 394, 407
 Carvone, 25, 205, 206, 394, 395, 408, 409, 412, 809, 810

- Carvopinone, 447, 809
 Carvotanacetone, 43, 406, 428, 810
 Carvoxime, 784
 Caryophyllene, 99, 264, 716, 717, 750, 757, 776, 778, 782, 784, 785, 787
 Caryophyllene alcohol, 102, 123, 777
 Caryophyllene oxide, 100, 716
 Caryophyllenic acid, 104, 105
 Cedar camphor, 284
 Cedranone, 117
 Cedrenal, 117
 Cedrene, 116, 283, 284, 285
 Cedrene dicarboxylic acid, 117
 Cedrene dicarboxylic acid anhydride, 117
 Cedrene-glycol, 116, 117
 Cedrene keto acid, 117
 Cedrenene, 283, 284
 Cedrenol, 117, 283
 Cedrenone, *see* Cedrone
 Cedrol, 116, 284, 792
 Cedrone, 117, 120
 Chamazulene, 128, 131, 132
 Chamene, 745
 Chavibetol, 514
 Chavicol, 505
 Chavicol methyl ether, 506
 Chlorides—preparation, 781
 Chlorine, 780
 Chloroacetic acid, 825
 Chlorobenzazides—preparation, 800
p-Chlorobenzazide, 825
 Chlorobenzhydrazides, 814
 Chlorobenzoylazide, 826
p-Chlorobenzyl isothiourrea hydrochloride, 829
p-Chlorobenzyl pseudothiuronium chloride, 829
p-Chlorophenacyl bromide, 828, 830
p-Chlorophenacyl esters, 828
p-Chlorophenylhydrazine hydrochloride, 813
 Chlorosulfonic acid, 798, 823
 Chromatographic method, 772
 Chromic acid, 775
 Chromic anhydride, 775
 Chrysantone, 765
 Cinchonidine, 794
 Cineole, 34, 43, 191
 1,4-Cineole, 202, 712
 1,8-Cineole, 708, 712
 Cineolic acid, 710
 Cineol-resorcinole, 709
 Cinnamaldehyde, 354, 817
 "Cinnamein," 639
 Cinnamic acid, 14, 355, 598, 645, 647, 649, 650, 780
 Cinnamic acid benzyl ester, 649
 Cinnamic acid cinnamyl ester, 650
 Cinnamic acid ethyl ester, 647
 Cinnamic acid methyl ester, 644
 Cinnamic alcohol, 295, 650, 792, 801
 Cinnamic aldehyde, 354, 809
 Cinnamonol, 756
 Cinnamyl alcohol, 294, 295, 799
 Cinnamyl cinnamate, 296, 650
 Citral, 168, 169, 170, 172, 173, 176, 324, 326, 334, 337, 338, 339, 381, 382, 458, 807, 809
 Citral-enol acetate, 333
 Citraptene, 669
 Citronellal, 181, 182, 208, 209, 330, 332, 336, 382, 587, 718, 807, 809
 Citronellic acid, 182, 341, 586
 Citronellol, 171, 172, 178, 332, 341, 623, 624, 625, 794, 802
 Citronellyl acetate, 624
 Citronellyl butyrate, 625
 Citronellyl formate, 183, 623
 Citroptene, 669
 Civet, 490
 Civetol, 491
 Civetone, 300, 490
 Clausenan, 702
 Clovene, 123
 Clovenic acid, 123
 "Cnidium lactone," 694
 Color tests, 772, 824
 Combanene, 756
 Combanol, 756
 Condensation reactions, 805
 Congealing point, 1
 Copaene, 92, 122
 Copaene ketonic acid, 122
 Costene, 747
 Costol, 612, 756
 Costus acid, 612, 767
 Costusic acid, 612
 Costus lactone, 767
 Costusolactone, 767
o-Coumaric acid, 661
p-Coumaric acid methyl ether, 604
 Coumarin, 657, 659, 660, 662, 664, 666, 668
 Coumarin—isolation, 668
 Coumarin glucosides, 662
 Coumarinic acid, 660, 661, 664, 668
 Coumarone, 657, 659, 660
 "Crataegon," 478
 Crithmene, 40
 Crotonaldehyde, 807
 Crotonic acid, 723
 Crotonic acid nitrile, 723
 "Crotonyl" mustard oil, 738
 Croweacin, 533
l-Cryptal, 388
 Cryptol, 299
 Cryptomeradol, 757, 764
 Cryptomerene, 125 (*see also* Diterpene table)
 Cryptomeriol, 764
 Cryptone, 299, 388
 Cryptotaenene, 12
 Cubeb camphor, 287, 768
 Cubebol, 287
 Cucumber alcohol, 164
 Cumaldehyde, 352
p-Cumamol, 499
 Cumic acid, 353
 Cumic alcohol, 297
 Cuminal, 352, 807
 Cuminaldehyde, 39, 344, 352

- Cumenic alcohol, 297
 Cumenic aldehyde, 352
 Cuminy alcohol, 297
 Cupressene, 125 (see also Diterpene table)
 Curcumenes, 89, 784
 Curcumone, 450, 451
 Cyanacetic acid, 330
 Cyanhydrin reaction, 804
 Cyanic acid gas, 801
 Cyanides, 721, 833
 Cyanoacetic acid reaction, 807
 Cyanuric acid, 801
 β -Cyclocitral, 349
 Cyclocitrylideneacetone, 458
 Cyclofenchene, 74, 777, 781
 α -Cyclogeranic acid, 590
 Cyclogeraniol, 173
 Cyclogeranyl acetate, 622
 Cycloheptadecanone, 491, 492
 9-Cycloheptadecenone, 490
 Cyclohexane, 18
 Cyclohexylamine, 832
 Cyclononadecanone, 492
 Cyclopentadecanone, 493, 689
 Cyclopulegone sulfonic ester, 699
 Cyclotridecanone, 492
 Cymbopol, 273
 Cymene, 45, 788
p-Cymene, 16, 19, 25, 28, 35, 37, 38, 41, 52, 197, 231, 332, 334, 428, 775, 776, 788
 1,2,4-Cymenesulfonic acid, 17
 1,3,4-Cymenesulfonic acid, 17
 "Cymol," 16
 Cyperene, 749, 759
 Cyperol, 759
 Cyperone, 453
 Cypress camphor, 284
- Dacrydene**, 745
 Damascenic acid, 655
 Damascenine, 654
 Darwinol, 754
 Daucol, 763
 Decanal, 306, 316, 324
 Decanoic acid, 574
 1-Decanol, 156
 Decarboxylation, 827
n-2-Decen-1-al, 324
n-1-Decenaldehyde, 324
 Decenoic acid, 324
n-Decyl alcohol, 156
n-Decylaldehyde, 306, 316
n-1-Decylenic aldehyde, 324
n-Decylic acid, 574
 Dehydration of alcohols, 791
 Dehydroangustione, 484, 486
 Dehydrogenation, 776
 Dehydrogeranic acid, 589
 Dehydro-turmerone, 450
 Diacetyl, 373, 379
 Diallyl disulfide, 731
 Diallyl trisulfide, 731
 Diamine, 810
pp'-Diaminodiphenylurethane, 830
 Dianethole, 510
- α -Dianisidine, 788
 Diarylurea, 798
 Diasarone, 537
 Dibenzyl, 788
 Dibenzylamine, 832
 1,4-Dichloro-*p*-menthane, 34
 Dicitronelloxide, 125, 718
 Di-*d*-clausenan, 702
 Dicrotyl sulfide, 731
 Dicyclohexylamine, 832
 Didymocarpene, 748
 Diels and Alder reaction, 786
 "Diene synthesis," 786
 Diethylaniline, 779
 Di-hydrazones, 812
 Dihydroambrettolic acid, 595
 Dihydro- γ -atlantol, 449
 Dihydroauraptene, 673
 Dihydroauraptenic acid, 673
 "Dihydrocalameone," 280
 Dihydrocarveol, 34, 205, 414
 Dihydrocarvone, 205, 206, 408, 454
 Dihydrocarvone hydrobromide, 448
 Dihydrocarvylamine, 43
 Dihydrocarvylxanthogenamide, 206
 Dihydrocaryophyllene nitrosate, 102
 Dihydrocivetol, 492, 493
 Dihydrocivetone, 492
 Dihydro "cnidium lactone," 695
 Dihydrocostus lactone, 612, 767
 Dihydrocostusolactone, 767
 Dihydrocoumarin, 661
 Dihydrocumaldehyde, 46
 Dihydrocumin alcohol, 47
 Dihydrocuminaldehyde, 39, 342
 Dihydrocuminic acid, 185
 Dihydrocuminic aldehyde, 185
 Dihydrocuminyamine, 46
 Dihydrofarnesene, 84
 Dihydro- γ -ionone, 465
 Dihydro-irane, 467
 Dihydro-irone, 467
 Dihydroisopimpinellin, 682
 Dihydrojasmane, 487
 Dihydrojunene, 746
 Dihydromatsutake alcohol, 153
 Dihydromyrcene, 8, 11
d-Dihydromyrtene, 754
 Dihydroperillene, 700
 $\Delta^{1,2}$ -Dihydroperillyl alcohol, 345
 Dihydrosabinene, 53
 α -Dihydrosedanolic acid, 695
 Dihydrosedanolid, 695
 Dihydrosesquictronellene, 83
 Dihydroteresantallic acid, 113
 Dihydro- α -terpineol, 186
 Dihydroxanthotoxol, 679
 1,2-Dihydroxy-4-allyl-benzene, 513
p-Dihydroxybenzene, 549
 Dihydroxycarotol, 763
 2,4-Dihydroxycinnamic acid, 667
 α, α' -Dihydroxy- α -methyl- α' -isopropyl-adipic acid, 36
 α, δ -Dihydroxy- α -methyl- δ -isopropyladipic acid, 197, 199

- Dihydrozingiberene, 88
 Di-indyl, 726
 Di-isoeugenol, 522
 Diketomonocarboxylic acid, 449
 β -Diketones, 812
 Dillapiolaldehyde, 539
 Dillapiole, 539
 Dillapiolic acid, 539
 Dimedone reaction, 805, 806
 1,2-Dimethoxy-4-allylbenzene, 519
 3,4-Dimethoxybenzaldehyde, 363
 1,4-Dimethoxybenzene, 551
 3,4-Dimethoxybenzoic acid, 519, 602
 Dimethoxycoumaric acid, 670
 5,7-Dimethoxycoumarin, 669
 5,6-Dimethoxyfurano-4',5',7,8-coumarin, 687
 5,8-Dimethoxyfurano-2',3',6,7-coumarin, 682
 3,4-Dimethoxyphenyl acetic acid, 519
 3,4-Dimethoxyphenylisocyanate, 799
 1,3-Di-*p*-methoxyphenyl-2-methylpropane, 510
 1,2-Dimethoxy-4-propenylbenzene, 523
 4,4'-Dimethoxystilbene, 510
 Di-*p*-methoxystilbene, 510
cis- α,β -Dimethylacrylic acid, 585
trans- α,β -Dimethylacrylic acid, 584
 β,β -Dimethylacrylic acid, 583
 γ,γ -Dimethylallyl alcohol, 512
 Dimethyl anthranilate, 653
 Dimethyl camphor, 815
 3,6-Dimethyl-coumaronetetrahydride-(4,5,6,7), 699
 5,5-Dimethyl-cyclohexane-1,3-dione, 805
 Dimethylglyoxal, 379
 2,6-Dimethyl-1,5-heptadiene, 590
 2,6-Dimethyl-1,5-heptadiene-1-carboxylic acid, 589
 2,6-Dimethyl-1,6-heptadiene-1-carboxylic acid, 589
 β,ζ -Dimethyl- $\Delta^{\alpha\gamma\epsilon}$ -heptatriene, 590
 2,6-Dimethyl-1,3,5-heptatriene-1-carboxylic acid, 589
 2,3-Dimethyl-2-hepten-6-one, 468
 1,4-Dimethyl-7-isopropyl azulene, 131
 2,4-Dimethyl-7-isopropyl azulene, 136
 4,8-Dimethyl-2-isopropyl azulene, 131
 1,6-Dimethyl-4-isopropylidene-6-hydroxynaphthalene, 277
 1,5-Dimethyl-3-isopropyl naphthalene, 457
 1,6-Dimethyl-4-isopropyl naphthalene, 81
d-1,1-Dimethyl-2- γ -ketobutylcyclopropane-3-carboxylic acid, 52
 Dimethyl ketone, 373
 2,6-Dimethyl-5-methylol-2,6-heptadiene, 177
 3,7-Dimethyl-2,6-octadien-1-al, 326, 327
 3,7-Dimethyl-2,7-octadien-1-al, 326, 327
 2,6-Dimethyl-1,6-octadien-8-ol, 171, 174
 2,6-Dimethyl-2,6-octadien-8-ol, 171, 174
 3,7-Dimethyl-1,6-octadien-3-ol, 167
 3,7-Dimethyl-1,7-octadien-3-ol, 167
 2,6-Dimethyl-4-octanone, 385
 2,6-Dimethyl-1,5,7-octatriene, 10
 2,6-Dimethyl-2,5,7-octatriene, 10
 β,ζ -Dimethyl- $\Delta^{\alpha\gamma\epsilon}$ -octatrienoic acid, 589
 2,6-Dimethyl-2,5,7-octatrien-4-one, 385
 3,7-Dimethyl-6-octen-1-al, 336
 3,7-Dimethyl-7-octen-1-al, 336
 2,6-Dimethyl-1-octen-8-ol, 178
 2,6-Dimethyl-2-octen-8-ol, 179
 2,6-Dimethyl-7-octen-4-one, 383
 Dimethyl sulfide, 730
 Dimethyl tetracycloivetol, 301
 Dimethyl tetracycloheptadecenol, 301
 Dimyrcene, 9
 Dimyristyl carbinol, 768
 Dinitroaniline, 800
 3,5-Dinitrobenzazide, 825
 Dinitrobenzoates—preparation, 797
 3,5-Dinitrobenzhydrazide, 814
p-Dinitrobenzoates, 796
 3,5-Dinitrobenzoates—preparation, 796
 3,5-Dinitrobenzoyl chloride, 824
 2,4-Dinitrochlorobenzene, 825
 3,5-Dinitro-4-methylbenzazide, 825
 2,4-Dinitrophenylhydrazine, 811, 812
 2,4-Dinitrophenylhydrazones—preparation, 812
 3,5-Dinitrophenylisocyanate, 799
N-(2,4-Dinitrophenyl)-*N'*-methyl-nitrourea, 800
 2,4-Dinitrophenyl methylurethane, 801
 Dinitrophenyl semicarbazide, 819, 820
 Di-*p*-nitrophenylurea, 799
p-Dinitrophenylurethanes—preparation, 799
 2,4-Dinitrophenylurethanes—preparation, 800, 801
 Diosphenol, 399, 542
 Dipentene, 25, 27, 34, 38, 45, 49, 169, 191, 201, 777, 779, 780, 782, 784
 Dipentene dihydrochloride, 25, 33, 49, 51, 52
 Diphellandrene, 48
 Diphenylcarbamates—preparation, 824
 Diphenylcarbonyl chloride, 800, 824
asym-Diphenylhydrazine hydrochloride, 813
 Diphenylurea, 799
 Diphenylurethanes—preparation, 800, 824
 Diterpenes, 125
 Diterpene table, facing p. 126
 Dithiocarboxylic acid, 802
 Dithymoquinone, 555
 Divinyl sulfide, 730
 Dodecanal, 317, 324
n-Dodecanoic acid, 576
n-2-Dodecen-1-al, 324, 325
n-1-Dodecenaldehyde, 325
n-Dodecylaldehyde, 317
n-1-Dodecylenic aldehyde, 325
n-Dodecylic acid, 576
 Doebner reaction, 806
 Doremol, 387
 Doremone, 387
 Dysoxylonene, 749
 Elemazulene, 128
 Elemicin, 534
 Elemol, 128, 262, 273

- Emulsin, 721
 Enanthal, 305
 Enanthaldehyde, 313
 Enanthic acid, 570
 Epoxycarene, 714
 Epoxydihydrocaryophyllene, 716
 2,3-Epoxy-2,6-dimethyl-7-octen-6-ol, 707
 Epoxylinalool, 707
 1,4-Epoxy-*p*-menthane, 712
 1,8-Epoxy-*p*-menthane, 708
 Equinopanacene, 751
 Equinopanacol, 764
 Eremophilone, 451
 Erythritol, 40
 "Esdragol," 506
 Ester exchange, 792
 Ester number, 831
 Esters, 615, 792, 831
 aliphatic, 618
 aromatic, 635
 terpene, 620
 Esters containing nitrogen, 651
 Estragole, 506
 Ethane-1,2-dicarboxylic acid, 592
 Ethanol, 142
p-Ethoxyphenol, 552
 Ethyl acetate, 618
 Ethyl alcohol, 142, 559, 618, 638, 642, 647, 792
 Ethyl *n*-amylcarbinol, 152
 Ethyl *n*-amyl ketone, 376
 Ethyl benzoate, 637
 Ethyl cinnamate, 647
 Ethyl citronellate, 181
 Ethylenediamine, 832
 Ethyl nitrite, 782
 Ethyl salicylate, 642
 "Ethylvanillin," 364
 "Eucalyptol," 708
 Eucazulene, 135
 Eudalene, 81, 82, 108, 114, 263, 268, 272, 274, 282, 457, 776, 790
 Eudalene picrate, 82
 Eudalene styphnate, 82
 Eudalinol, 457
 Eudesmene, 82, 109, 111, 748
 Eudesmol, 81, 108, 109, 111, 272, 274, 756, 757, 758, 776, 802
 Eudesmyl acetate, 274
 "Eugenic acid," 516
 Eugenine, 669
 Eugenol, 100, 516, 518, 519, 520, 521, 544
 Eugenol acetate, 518
 Eugenol methyl ether, 519
 Eugenone, 544
 Evodene, 746
 Exaltolide, 494, 594, 688
 Exaltone, 492, 493

Farnesal, 258, 260
 Farnesenes, 84, 259
 Farnesol, 128, 258
 2-Fenchanol, 251
 Fenchenes, 70, 780, 782, 784

 α -Fenchene, 71, 256, 777
 α -Fenchene dibromide, 781
 β -Fenchene, 72
 γ -Fenchene, 73
 δ -Fenchene, 73
 Fenchol, 238, 251
 Fenchone, 251, 254, 418
 Fenchyl alcohol, 70, 71, 73, 251
 d -Fenchylamine, 71
 Fenchyl chloride, 71
 Fenchylene, 73
 Feniculin, 512
 Ferric chloride, 824
 Fluconapin, 738
 Fluorene, 788
 2-Fluorenylisocyanate, 799
 Fokienol, 755
 Foliol, 756
 Formaldehyde, 305, 307, 417
 Formic acid, 559, 560, 563, 564, 565, 621, 625, 627
 Formonitrile, 721
 Freezing point, 1
 2-Furaldehyde, 367
 Furan derivatives, 697, 833
 Furan-2,3-dicarboxylic acid, 686
 Furanocoumarins, 668
 Furano-4',5',7,8-coumarin, 686
 Furfural, 367, 373, 807
 α -Furfuraldehyde, 367
 Furfurylaldehyde, 367
 Furo-4',5',7,8-coumarin, 686
 β -Furyl-isopentyl-ketone, 483
 Fusanol, 269, 802

Galipene, 751
 Galipol, 760
 Gaultherin, 640
 Geranial, 326, 334
 Geranic acid, 332, 589
 Geranic acid nitrile, 162
 Geraniol, 34, 163, 168, 169, 170, 171, 174, 175, 176, 177, 180, 182, 183, 273, 332, 621, 686, 792, 794, 802
 Geranyl acetate, 177, 333, 334, 561, 621, 627
 Geranyl formate, 621
 6-Geranyl-7-hydroxycoumarin, 675
 Girard type reagents, 811, 814, 815, 816
 Globulol, 286
 Glucochlearin, 738
 Glucotrapacolin, 740
 Glutaric acid, 688
 Glycols, 774
 Grignard reaction, 804
 Guaiazulene, 128, 129, 134, 279, 288
 S-Guaiazulene, 111, 128, 131, 134, 135
 Se-Guaiazulene, 128, 134, 136
 Guaiene, 111, 130, 134, 279
 Guaiol, 128, 129, 130, 134, 278, 756
 Guanylhydrazine, 811, 813
 Gurjunazulene, 135
 Gurjunenes, 119, 775
 Gurjunene ketone, 120
 Gynocardin, 721

- Halides, 780**
 Halogen acids, 792
 Halogenation, 780
 Heerabolene, 124, 780
 Helenine, 691, 692
 Heliotropin, 365, 530
 Hendecanoic acid, 575
 2-Hendecanol, 156, 794
 10-Hendecen-2-ol, 166
n-Heptaldehyde, 305, 313, 807
 Heptanal, 305, 313
n-Heptane, 7
 Heptanoic acid, 313, 570, 572
 2-Heptanol, 150, 375, 794
n-Heptoic acid, 570
sec-Heptyl alcohol, 150
n-Heptylic acid, 377, 569, 570, 571, 575
n-Heptyl methyl ketone, 376
 Heraclin, 680
 Herniarin, 667
n-Hexadecanoic acid, 579
 Hexadecylic acid, 579
 Hexahydroagropyrene, 16
 Hexahydrozingiberene, 88
 Hexanal, 305, 306, 312
 Hexanoic acid, 569, 572
 1-Hexanol, 148
 2-Hexen-1-al, 319
 α,β -Hexenic acid, 586
 2-Hexenoic acid, 320
 3-Hexenol, 794, 802
 α,β -Hexenol, 158
 β,γ -Hexenol, 158
 3-Hexen-1-ol, 158, 164, 320, 322
trans-3-Hexen-1-ol, 319
n-Hexyl alcohol, 148
 α,β -Hexylenaldehyde, 319
n-Hexylic acid, 569
 Homoanistic acid, 507
cis-Homocaronic acid, 51
 Homocaryophyllenic acid, 264
 Homoterpenyl methyl ketone, 192
dl-Homothujadicarboxylic acid, 76
 Homoveratric acid, 519
 Humulene, 107, 782, 784
 Hydantoin derivatives, 820
 Hydrates, 776
 Hydration, 776
 Hydrazide, 811, 814
 Hydrazines, 810
 Hydrazine carboxylamine, 811
 Hydrazones, 811, 815
 Hydrocarbons, 5, 745, 774
 Hydrocarbons—addition products, 776
 Hydrocarbons—dehydrogenation, 776
 Hydrocarbons—oxidation, 774
 Hydrocarbons, aliphatic, 7
 aromatic, 12, 753
 Hydrochlorides—preparation, 778
 Hydrocinnamaldehyde, 356
 Hydrocinnamic acid, 295, 356, 724
 Hydrocinnamic acid nitrile, 724
 Hydrocinnamyl alcohol, 294
 Hydrocoumarinic acid, 661
 Hydrocyanic acid, 373, 721
 Hydrodiherniarin, 667
 Hydrogenation, 777
 Hydrogen bromides—preparation, 779
 Hydrogen cyanide, 721
 Hydrogen halides—preparation, 778
 Hydrogen iodides—preparation, 779
 Hydrogen sulfide, 721, 729, 730, 790
 Hydrolysis, 831
 Hydroquinol, 549
 Hydroquinone, 549
 Hydroquinone dimethyl ether, 551
 Hydroquinone monoethyl ether, 552
 Hydroquinone monomethyl ether, 551
o-Hydroxyacetophenone, 477
 α -Hydroxy aldehydes, 812
p-Hydroxyallylbenzene, 505
 1-Hydroxy-4-allylbenzene, 505
 1- α -Hydroxy amyl- Δ^2 -tetrahydrobenzoic acid, 694
o-[α -Hydroxyamyl]-benzoic acid, 693
 2-Hydroxyanisaldehyde, 363
p-Hydroxyanisole, 479, 551
o-Hydroxybenzaldehyde, 357
o-Hydroxybenzoic acid, 599
 4-Hydroxybenzyl isothiocyanate, 742
p-Hydroxybenzyl mustard oil, 742
 2-Hydroxycamphane, 239
 8-Hydroxycarvotanacetone, 58
 Hydroxychavicol, 513
o-Hydroxycinnamic acid, 659
cis-Hydroxycinnamic acid, 660, 661
trans-Hydroxycinnamic acid, 660, 661
o-Hydroxycinnamic acid lactone, 664
 Hydroxycoumarins, 662
 5-Hydroxycoumarin, 667
 7-Hydroxycoumarin, 666
p-Hydroxycumene, 499
 2-Hydroxy-*p*-cymene, 503
 3-Hydroxy-*p*-cymene, 500
 5-Hydroxy-2-decenoic acid lactone, 688
 Hydroxydihydrocremophilone, 451
 2-Hydroxy-4,6-dimethoxyacetophenone, 543
 2-Hydroxy-4,6-dimethoxychalcone, 544
 2-Hydroxy-4,6-dimethoxy-3-methyl-isobutyrophenone, 545
 Hydroxyeremophilone, 451
 5-Hydroxyfurano-2',3',6,7-coumarin, 678
 8-Hydroxyfurano-2',3',6,7-coumarin, 678
 16-Hydroxy-7-hexadecenoic acid, 595
 16-Hydroxy-7-hexadecenoic acid lactone, 689
 Hydroxyhydrocarvone, 63
 Hydroxyimperatorin, 683
 8-Hydroxy-5-isoamylene-psoralene, 683
 α -Hydroxy-isobutyric acid, 565
 1-Hydroxy-4-isopropylbenzene, 499
p-Hydroxyisopropylbenzoic acid, 17
 α -Hydroxy ketones, 812
 Hydroxylamine, 809
 Hydroxylamine hydrochloride, 810
 Hydroxylamino-oxime, 810
cis-8-Hydroxy-*p*-menthane, 186
 2-Hydroxy-4-methoxyacetophenone, 525
 1-Hydroxy-2-methoxy-4-allylbenzene, 516
 2-Hydroxy-4-methoxybenzaldehyde, 363

- 4-Hydroxy-3-methoxybenzaldehyde, 361
 1-Hydroxy-2-methoxy-4-propenylbenzene, 521
 Hydroxymyristic acid, 593
 15-Hydroxypentadecanoic acid, 594
 15-Hydroxypentadecanoic acid lactone, 688
 15-Hydroxypentadecyclic acid, 594
 "Hydroxypeonol," 543
 Hydroxypeucedanin, 674
p-Hydroxyphenetol, 552
 γ -Hydroxypropyl methyl sulfide, 731
 5-Hydroxypsoralene, 678
 5-Hydroxypsoralene isoamylene ether, 684
 8-Hydroxypsoralene, 678
 8-Hydroxypsoralene isoamylene ether, 683
 Hydroxyterpenylic acid, 414
 4-Hydroxy-2,6,6-trimethyl-1-tetrahydrobenzaldehyde, 348
 Hypnone, 474
- Imino compounds**, 725, 833
 Imperatorin, 660, 666, 683
allo-Imperatorin, 683
 Indole, 725, 728
 Iodides—preparation, 781
 Iodine, 780
p-Iodobenzhydrazide, 814
p-Iodobenzhydrazones—preparation, 814
 4-Iodo-diphenyl-4'-isocyanate, 799
 Iodoform, 143, 374
p-Iodophenacyl bromide, 828, 830
p-Iodophenylisocyanate, 824
 Ionone ring, 484
 Ionones, 335, 458, 495
 Ionones—separation, 462
 α -Ionone, 458, 460
 β -Ionone, 458, 461
 ψ -Ionone, 459
 pseudo-Ionone, 459
 Ipomoeol, 760
 Irene, 472
 Irol, 472
 Irones, 466, 495
 Irone, natural, 469
 α -Irone, 470
 β -Irone, 471
 γ -Irone, 470
 Ishwarene, 751
 Ishwarol, 760
 Ishwarone, 765
 Isoalantolactone, 691
 Isoamyl alcohol, 147, 643
 Isoamyl salicylate, 643
 "Isoanethole," 510
 Isoapiole, 538
 Isoartemisia ketone, 386
 Isoauraptene, 672, 674
 Isobergaptene, 686
 Isobetel phenol, 515
 Isoborneol, 66, 67, 69, 239, 240, 241, 243, 245, 247, 430, 434, 630, 777, 792
 Isoborneol esters, 430
 Isobornyl acetate, 246, 630
 Isobornyl acid phthalates, 245
 Isobornyl chloride, 66, 67, 778
 Isobornyl-*l*-menthylcarbamate, 245
 Isobutyl alcohol, 145
 Isobutylaldehyde, 807
 Isobutyric acid, 145, 564
 Isocadinene, 92, 94, 95, 776, 777, 778
 Isocalamol, 541
 Isocamerene, 753
 Isocamphoric acid, 606, 607
 Isocamphoronic acid, 434, 437
 Isocarvomenthol, 215
 Isocedrene dicarboxylic anhydride, 117
 Isocedrenol, 117
 Isochamene, 745
 Isochavibetol, 515
 Isocitral, 26, 333, 334
 Isocostene, 757
 Isocroweacin, 534
 Isocyanates, 798
 Isodiprene, 49
 Isoelemicin, 534, 535
 Isocugenol, 521, 524
 Isoeugenol methyl ether, 523, 524
 Isofenchene, 73
 Isofenchol, 255, 422
 Isofenchone, 421
 Isofenchyl acetate, 71, 777
 Isofenchyl alcohol, 71, 72, 74, 255, 421, 422, 777
 Isofenchyl chloride, 71, 72
 Isofenchylxanthates, 71, 74
 Isofokienene, 755
 Iso- α -gurjunene, 120
 Isohelenine, 691
 β -Isohexenyl-furan, 700
 Isohydroxycuminic acid, 504
 Isohydroxypeucedanin, 674
 Isoimperatorin, 660, 684
 Isolimonene, 29
 Isomenthol, 216, 218, 221, 222, 399, 417
 Isomenthone, 216, 390, 391, 423
 Isomyristicin, 532
 Isophyllocladene, *see* Diterpene table
 Isopimpinellin, 660, 676, 682, 687
 Isopinene, 72
 Isopinocampheol, 442
 Isopinocampnone, 442, 443
 Isopiperitenone, 417
 Isoprene, 7, 128, 386
 4-Isopropenyl-1-cyclohexenaldehyde, 342
 4-Isopropenyl-1-cyclohexenecarbinol, 184
 2-Isopropenyl-5-methyl-4-hexen-1-ol, 177
 Isopropyl acetic acid, 566
 Isopropylaldehyde, 807
p-Isopropylbenzaldehyde, 352
p-Isopropylbenzyl alcohol, 297
 Isopropylcarbinol, 145
 4-Isopropyl-1-cyclohexenaldehyde, 344
 4-Isopropyl-2-cyclohexen-1-ol, 299
 4-Isopropyl-2-cyclohexen-1-one, 48, 388
 1-Isopropyl-1,2-cyclopropanedicarboxylic acid, 440, 441
 Isopropylglutaric acid, 389, 407
 Isopropylideneacetic acid, 583
 4-Isopropyl-1-methylene-2-cyclohexene, 46
p-Isopropylphenol, 499

- Isopulegol, 182, 208, 340, 792, 802
 Isopulegol acetate, 341
 Isopulegol formate, 338
 Isopulegone, 404
 Isosafrole, 528, 529
 Isothiocyanallyl, 734
 Isothujone, 249, 423, 424, 428
 Isothujyl alcohol, 249
 Isovaleraldehyde, 305, 311, 807
 Isovaleric acid, 312, 384, 449, 566, 634
 Isozingiberene, 81, 87, 91, 261, 776
 Isozingiberene dihydrochloride, 87, 91, 262
- Jasmone**, 486
 Junene, 746
 Junipene, 753
 Juniperene, 761
 Juniperic acid, 595
 Juniperol, 761
- Kaurene**, 125 (*see also* Diterpene table)
 Kessazulene, 135, 288
 Kesso glycol, 288, 289
 Kesso glycol diacetate, 288, 289
 Kessyl acetate, 289
 Kessyl alcohol, 135, 288
 Kessyl alcohol acetate, 288
d-Ketocaprinic acid, 688
 5-Ketocarane, 447
 2-Ketodecylic acid, 166
 Ketomethylene compounds, 807
 Ketones, 371, 765, 774, 804
 - aliphatic, 373
 - saturated, 373
 - unsaturated, 381
 - aromatic, 474
 - large ring, 489
 - miscellaneous, 480
 - sesquiterpene, 448
 - terpene, bicyclic, 418
 - cyclic, 388
 - monocyclic, 388
- Ketones of doubtful constitution, 494
L-Ketonic acid, 225
 3-Keto-sabinane, 423
 Ketoximes, 810
 Kiganene, 748
 Kiganol, 757
 Kuromatsuol, 761
- Lactarazulene**, 128
 Lactic acid, 565
 Lactones, 657, 659, 767, 833
 Laevulinic acid, 170, 176
 Lanceol, 270
 Lansene, 751
 Lansol, 752
 Lauraldehyde, 317
 Lauric acid, 317, 576
 Laurocerasin, 721
 Lavandulol, 111, 177, 802
 "Leaf alcohol," 158
 "Leaf aldehyde," 306, 319
 Ledene, 281
 Ledol, 129, 280
- S-Ledum azulene, 281
 Se-Ledum azulene, 281
 Ledum camphor, 280
 Leptospermol, 488
 Leptospermone, 488
 Levulinic aldehyde, 676
 Libocedrene, 752
 "Ligusticumic acid," 609, 693
 "Ligusticum lactone," 609, 693
 Limene, 84
 Limettin, 659, 662, 669, 673, 676
 Limonene, 20, 22, 27, 776, 780, 782, 784, 787
dl-Limonene, 27
 Limonene nitrolaniline, 786
 Limonene nitrosochloride, 782, 784, 786
 Limonene tetrabromide, 781
 Limonetrile, 25
 Linalool, 34, 167, 168, 169, 171, 172, 173,
 189, 620, 707, 718, 792, 799, 802
 Linalool dioxide, 170
 Linaloolene, 8
 Linalool monoxide, 170, 707
 Linalyl acetate, 168, 177, 334, 561, 620, 627
 Linoleic acid, 592
 Linolenic acid, 592
 Liquidene, 747
 Longifolene, 121, 780
 Luparenol, 762
 Luparol, 766
 Luparone, 765
 Lusitanicoside, 505, 506
- Maali alcohol**, 761
 Machilol, 757, 758
 Macrocarpol, 761
 Maleic anhydride—reactions, 786, 787,
 823
 Malol, 768
 Malonic acid esters, 792
 Marmelosin, 683
 Maroniol, 764
 Massoilactone, 688
 Matico camphor, 762
 Matsutake-alcohol, 161
 Melilotic acid, 661
 Melting point, 1
 1,8(9)-*p*-Menthadien-7-al, 342
 Menthadienes, 19
 - 1,8(9)-*m*-Menthadiene, 32
 - 6,8(9)-*m*-Menthadiene, 32
 - p*-Menthadienes, 20
 - 1(7),2-*p*-Menthadiene, 46
 - 1,3-*p*-Menthadiene, 35
 - 1(7), 3-*p*-Menthadiene, 39
 - 1,4-*p*-Menthadiene, 40
 - 1,4(8)-*p*-Menthadiene, 30
 - 1,5-*p*-Menthadiene, 41
 - 1,8(9)-*p*-Menthadiene, 22
 - 2,8(9)-*p*-Menthadiene, 29
 - 1,8(9)-*p*-Menthadien-7-ol, 184
 - 6,8(9)-*p*-Menthadien-2-ol, 203
 - 1,4(8)-*p*-Menthadien-3-one, 416
 - 1,8(9)-*p*-Menthadien-3-one, 417
 - 6,8(9)-*p*-Menthadien-2-one, 412
 - m*-Menthane, 18, 19

- o*-Menthane, 18, 19
p-Menthane, 18, 19
p-Menthane-1,4-diol, 202
p-Menthane-1,8-diol, 200
p-Menthane-1,2,4,5-tetrol, 40
p-Menthane-1,2,4,8-tetrol, 30
p-Menthane-1,2,4-triol, 199
p-Menthane-1,2,8-triol, 192
p-Menthane-1,3,4-triol, 197
p-Menthane-1,4,8-triol, 195
p-Menthane-2,8,9-triol, 207
2-*p*-Menthanol, 213
3-*p*-Menthanol, 216, 226
8-*p*-Menthanol, 186
p-Menthan-2-one, 394
p-Menthan-3-one, 390
p-Menthan-2-one-8,9-diol, 409
1-*p*-Menthen-7-al, 344
Menthenes, 19
 Δ^3 -Menthene, 20
1-*p*-Menthene-4,6-diol, 231
8(10)-*p*-Menthene-1,2-diol, 25
2-*p*-Menthene-1,4-dioxide, 715
1-*p*-Menthen-3-ol, 211
1-*p*-Menthen-4-ol, 198
1-*p*-Menthen-8-ol, 188
3-*p*-Menthen-1-ol, 197
4(8)-*p*-Menthen-1-ol, 195
4(8)-*p*-Menthen-3-ol, 207
8(9)-*p*-Menthen-1-ol, 193
8(9)-*p*-Menthen-2-ol, 205
8(9)-*p*-Menthen-3-ol, 208
1-Menthen-3-one, 197
3(8)-*m*-Menthen-2-one, 410
3(8)-*m*-Menthen-4-one, 410
1(7)-*p*-Menthen-2-one, 410
1-*p*-Menthen-3-one, 211, 396
3-*p*-Menthen-2-one, 411
4(8)-*p*-Menthen-3-one, 400
6-*p*-Menthen-2-one, 406
8(9)-*p*-Menthen-2-one, 408
8(9)-*p*-Menthen-3-one, 404
Menthofuran, 699
Menthol, 20, 208, 209, 213, 216, 403, 416, 445, 632, 634, 699, 799, 802
d-Menthol, 218
l-Menthol, 210, 220, 224, 226
dl-Menthol, 222, 398, 399
Menthol-isomenthol series, 248
Menthone, 216, 225, 340, 390, 408, 416, 423, 699
l-Menthylidrazide, 814
Menthyl acetate, 632
Menthyl isovalerate, 634
Meranzin, 672
Mercaptan, 729, 790
Mercuric acetate, 823
Mercuric iodide, 817
Metanethole, 510
Metastyrene, 15
Methacrolein, 318
Methacrylic acid, 583
Methanol, 141
p-Methoxyacetophenone, 478
p-Methoxyallylbenzene, 506
p-Methoxybenzaldehyde, 358
o-Methoxybenzoic acid, 360
p-Methoxybenzoic acid, 360, 479, 509, 600
o-Methoxycinnamaldehyde, 360
p-Methoxycinnamaldehyde, 359
p-Methoxycinnamic acid, 360, 604
7-Methoxycoumarin, 667
7-Methoxy-8-(γ,γ -dimethylallyl)coumarin, 671
5-Methoxyfurano-2',3',6,7-coumarin, 680
8-Methoxyfurano-2',3',6,7-coumarin, 679
7-Methoxy-5-geranoxycoumarin, 670, 675, 682
1-Methoxy-2-hydroxy-4-allylbenzene, 514
3-Methoxy-2-methyl-aminobenzoic acid methyl ester, 654
3-Methoxy-*N*-methylantranilic acid methyl ester, 654
7-Methoxy-8-(3'-methyl butanyl-2')-coumarin, 671
2-Methoxy-3,4-methylenedioxypropenylbenzene, 534
2,4,5-Methoxynitrobenzene, 367
p-Methoxyphenol, 551
4-Methoxyphenylacetic acid, 480, 507
p-Methoxyphenylacetoin, 511
p-Methoxyphenylacetone, 479, 511
p-Methoxyphenylglyoxylic acid, 479, 509
p-Methoxyphenylisocyanate, 799
p-Methoxypropenylbenzene, 508
2-Methoxy-4-propenylphenol, 521
5-Methoxypsoralene, 680
8-Methoxypsoralene, 679
4-Methoxysalicylaldehyde, 363
p-Methylacetophenone, 476, 482
l-1-Methyl-4-acetyl-1-cyclohexene, 482
 β -Methyladipic acid, 225, 340, 341, 392, 403, 481
Methyl alcohol, 141, 373, 559, 636, 640
o-Methylaminobenzoic acid methyl ester, 653
Methyl *n*-amyl ketone, 375
Methyl anthranilate, 651
n-Methylantranilic acid methyl ester, 651, 653
Methyl benzoate, 636
3-Methylbutanal, 311
 α -Methylbutanoic acid, 567
 β -Methylbutanoic acid, 566
3-Methylbutanol, 147
2-Methyl-*n*-butyraldehyde, 311
 α -Methyl-*n*-butyric acid, 567
 β -Methyl-*n*-butyric acid, 566
Methyl chavicol, 506
Methyl cinnamate, 644
cis- α -Methylcrotonic acid, 585
trans- α -Methylcrotonic acid, 584
 β -Methylcrotonic acid, 583
 β -Methylcumaric acid, 360
1-Methyl-3-cyclohexanone, 403, 480
1-Methyl-1-cyclohexen-3-one, 416
3-Methyl-1-cyclopentadecanone, 489
1,2-Methylenedioxy-4-allylbenzene, 526
3,4-Methylenedioxybenzaldehyde, 365
3,4-Methylenedioxybenzoic acid, 601

- 1,2-Methylenedioxy-3,6-dimethoxy-4-allylbenzene, 537
 1,2-Methylenedioxy-5,6-dimethoxy-4-allylbenzene, 539
 1,2-Methylenedioxy-6-methoxy-4-allylbenzene, 531
 1,2-Methylenedioxy-6-methoxy-4-propenylbenzene, 532
 1,2-Methylenedioxy-4-propenylbenzene, 529
 1-Methylene-4-isopropylcyclohexan-2-one, 410
 1-Methylene-4-isopropyl-2-cyclohexene, 46
 1-Methylene-4-isopropyl-3-cyclohexene, 39
 Methyleugenol, 519
 Methyl ethyl acetic acid, 567
 β,β -Methyl ethyl propyl alcohol, 148
 Methylfenchyl xanthates, 71
 Methyl geranate, 590
 5-Methyl-geraniol, 468
 Methyl heptenol, 161
 α -Methyl heptenol, 161
 β -Methyl heptenol, 161
 2-Methyl-1-hepten-6-ol, 161
 2-Methyl-2-hepten-6-ol, 161
 Methyl heptenone, 162, 163, 170, 332, 335, 337, 381
 β -Methyl heptenone, 173
 2-Methyl-1-hepten-6-one, 381
 2-Methyl-2-hepten-6-one, 381
 Methyl heptenone carboxylic acid, 332
 Methyl *n*-heptylcarbinol, 154, 377
 Methyl *n*-heptyl ketone, 154, 376, 377, 378
 4-Methyl-5-hydroxy-7-methoxycoumarin, 669
 β -Methylindole, 728
 3-Methylindole, 728
 Methyl-ionone, 495
 6-Methyl- α -ionone, 466
 6-Methyl- β -ionone, 466
 6-Methyl- γ -ionone, 466
 Methyl isobutyl ketone, 384
 β -Methyl- δ -isobutyryl-*n*-valeric acid, 392
 Methylisoeugenol, 523
 1-Methyl-4-isopropenylcyclohexan-1-ol, 193
 1-Methyl-4-isopropenylcyclohexan-2-ol, 205
 1-Methyl-4-isopropenylcyclohexan-3-ol, 208
 1-Methyl-4-isopropenylcyclohexan-2-one, 408
 1-Methyl-4-isopropenylcyclohexan-3-one, 404
 1-Methyl-3-isopropenyl-1-cyclohexene, 32
 1-Methyl-3-isopropenyl-6-cyclohexene, 32
 1-Methyl-4-isopropenyl-1-cyclohexene, 22
 1-Methyl-4-isopropenyl-2-cyclohexene, 29
 1-Methyl-4-isopropenyl-6-cyclohexen-2-ol, 203
 1-Methyl-4-isopropenyl-1-cyclohexen-3-one, 417
 1-Methyl-4-isopropenyl-6-cyclohexen-2-one, 412
 1-Methyl-4-isopropylbenzene, 16
 2-Methyl-5-isopropyl-1,4-benzoquinone, 554
 1-Methyl-4-isopropyl-1,3-cyclohexadiene, 35
 1-Methyl-4-isopropyl-1,4-cyclohexadiene, 40
 1-Methyl-4-isopropyl-1,5-cyclohexadiene, 41
 1-Methyl-4-isopropylcyclohexane, 19
 1-Methyl-4-isopropylcyclohexane-1,4-diol, 202
 1-Methyl-4-isopropylcyclohexane-1,8-diol, 200
 Methyl-isopropylcyclohexanol, 18
 1-Methyl-4-isopropylcyclohexan-2-ol, 213
 1-Methyl-4-isopropylcyclohexan-3-ol, 216, 226
 1-Methyl-4-isopropylcyclohexan-2-one, 394
 1-Methyl-4-isopropylcyclohexan-3-one, 390
 1-Methyl-4-isopropyl-2-cyclohexene-1,4-dioxide, 715
 1-Methyl-4-isopropyl-1-cyclohexen-3-ol, 211
 1-Methyl-4-isopropyl-1-cyclohexen-4-ol, 198
 1-Methyl-4-isopropyl-1-cyclohexen-8-ol, 188
 1-Methyl-4-isopropyl-3-cyclohexen-1-ol, 197
 1-Methyl-4-isopropyl-1-cyclohexen-3-one, 396
 1-Methyl-4-isopropyl-3-cyclohexen-2-one, 411
 1-Methyl-4-isopropyl-6-cyclohexen-2-one, 406
 2-Methyl-5-isopropyl-1,4-hydroquinone, 553
 1-Methyl-4-isopropylidencyclohexan-1-ol, 195
 1-Methyl-4-isopropylidencyclohexan-3-ol, 207
 1-Methyl-3-isopropylidencyclohexan-2-one, 410
 1-Methyl-3-isopropylidencyclohexan-4-one, 410
 1-Methyl-4-isopropylidencyclohexan-3-one, 400
 1-Methyl-4-isopropylidene-1-cyclohexene, 30
 1-Methyl-4-isopropylidene-cyclohexen-3-ol, 334
 1-Methyl-4-isopropylidene-1-cyclohexen-3-one, 416
 1-Methyl-7-isopropyl-naphthalene, 81
 2-Methyl-5-isopropylphenol, 503
 3-Methyl-6-isopropylphenol, 500
 Methyl ketones, 808
 γ -Methyl-mercapto propyl alcohol, 731
 2-Methyl-6-methenyl-2,7-octadien-4-one, 385
 4-Methyl-5-methoxy-7-hydroxycoumarin, 669
 2-Methyl-6-methylene-2,7-octadiene, 8
 2-Methyl-6-methylene-7-octen-4-one, 384
 2-Methyl-6-methylenoctan-8-ol(?), 166
 Methyl- β -methylthiolpropionate, 732
 α -Methyl- β -naphthocinchonic acid, 807
 Methylnitramine, 800
 2-Methyl-2,4,8-nonatriene, 12
 2-Methyl-2,6,8-nonatriene, 12
 Methyl *n*-nonylcarbinol, 156
 Methyl *n*-nonyl ketone, 157, 377
 Methyl pentanoic acid, 569
 3-Methyl-1-pentanol, 148
 3-Methyl-2-[2'-penten-yl]-2-cyclopenten-1-one, 486
 1-Methylphenylhydrazine, 813
 Methyl phenyl ketone, 474

- Methylphloroglucinol dimethyl ether, 546
 Methylphloroisobutyrophenone dimethyl ether, 545
 Methylpinocampylxanthate, 55
 α -Methylpropanoic acid, 564
 2-Methylpropanol, 145
 α -Methylquinoline, 807
 Methyl salicylate, 617, 640
 Methylsuccinic acid, 392
p-Methyl-3-tetrahydroacetophenone, 482
 3-Methylthiol propyl ether, 731
 Methyl-*p*-tolyl carbinol, 477
 2-Methyl-6-(*p*-tolyl)-1-heptene, 89
 2-Methyl-6-(*p*-tolyl)-2-heptene, 89
 Methyl-*p*-tolyl ketone, 476
 Methyl-*p*-tolyl pinacone, 477
 Methylumbelliferone, 659, 667
 Methyl *n*-undecyl ketone, 378
 "Methylvanillin," 363
 Methylxanthates, 802
 Micranene, 749
 Microl, 766
 Microscopy, chemical, 772
 Mirene, 125 (see also Diterpene table)
 Mitsubene, 748
 Mixed anhydride, 793
 Moslene, 40
 Muscone, 300, 489
 Musk, 489
 Muskrat, 492, 493
 "Mustard oil," 734
 Mustard oils, 734
 Myrcenal, 9
 Myrcene, 780, 784, 787, 788
 β -Myrcene, 8, 11, 774, 778
 Myrcenic acid, 9
 Myrcenol, 9
 Myrcenone, 385
 Myristic acid, 559, 577, 578, 580
 Myristicin, 531
 Myristicinaldehyde, 532
 Myristicinic acid, 532
 Myronate of potassium, 734
 Myrosinase, 734
 Myrtenal, 234, 346, 347
 Myrtenol, 63, 233, 347
d-Myrtenol, 754
Naphthalene, 12, 790
 1,7-Naphthalenedicarboxylic acid, 692
 β -Naphthocinchoninic acid, 806, 807
 β -Naphthoquinoline, 807
 α -Naphthoquinone, 790
 β -Naphthylidrazide, 814
 Naphthylamine, 330, 806, 830
 α -Naphthylamine addition products, 797
 Naphthylhydrazine hydrochloride, 813
 Naphthylisocyanate, 798, 799, 824, 825
 Naphthyl semicarbazide, 820
 α -Naphthylurethanes—preparation, 798, 799
 Neocarvomenthol, 215
 "Neodihydrocarveol," 206
 Neoisocarvomenthol, 215
 Neoisomenthol, 216, 221, 222
 Neomenthol, 210, 219, 221, 222, 226
 "Neopinocampheol," 238
 Nepetalactone, 690
 Nepetalic acid, 607, 613, 690
 Nepetalic anhydride, 608, 613, 690
 Nepetic acid, 608
 Nepetonic acid, 608
 Neral, 326, 327, 334
 Nerol, 168, 169, 171, 172, 174, 623, 803
 Nerolidol, 96, 260
 Neryl acetate, 622
 Neutralization equivalent, 827
 Nickel as catalyst, 778
 "Niobe," oil of, 636
 Nitration, 823
 Nitric acid, 775
 Nitrites, 784
 1-Nitroanthraquinone-2-carboxylic acid, 803
 Nitrobenzazide, 800, 825, 826
 Nitrobenzene sulfonylhydrazide, 814
 Nitrobenzhydrazides, 814
p-Nitrobenzoates—preparation, 796
 Nitrobenzoylazide, 826
p-Nitrobenzoyl chloride, 824
p-Nitrobenzyl bromide, 825
p-Nitrobenzyl chloride, 825, 828
p-Nitrobenzyl esters, 827, 828
p-Nitrobenzyl ethers, 825
p-Nitrobenzyl iodide, 825
 Nitro compounds, 786, 790
 Nitrogen-containing compounds, 719
 Nitroguanylhydrazine, 813
 Nitrolamines—preparation, 785
 Nitro- α -phellandrene, 43
 Nitro- β -phellandrene, 46
p-Nitrophenylcarbamide, 799
p-Nitrophenylhydrazine, 811, 812, 813
p-Nitrophenylhydrazones—preparation, 812
 Nitrophenylisocyanates, 799
p-Nitrophenylurethanes—preparation, 798, 800
 3-Nitrophthalates, 796
 3-Nitrophthalic acid esters, 795
 3-Nitrophthalic anhydride, 795
 Nitrosates—preparation, 784
 Nitrosites—preparation, 784
 Nitrosocarene, 50
 Nitrosochlorides—preparation, 781, 782
 Nitrosohalides—preparation, 781
 Nitrosylchloride, 781, 782
 2,6-Nonadienal, 322
 α - ϵ -Nonadien aldehyde, 322
 2,6-Nonadien-1-ol, 164, 802
 Nonanal, 306, 315
 Nonane, 7
 Nonanoic acid, 573
 1-Nonanol, 153, 165
 2-Nonanol, 154
 2-Nonanone, 376
n-Nonyl alcohol, 153
n-Nonylaldehyde, 154, 306, 315
n-Nonylic acid, 154, 573
 Nopinene, 62
 Nopinic acid, 63
 π -Norborneol, 229

- Norcamphene, 79
 π -Norcamphor, 438
 Norcaryophyllenic acid, 104, 105
 Norcedrene, 116
 Norcedrene dicarboxylic acid, 117
 Norcedrene keto acid, 117
 π -Norisoborneol, 229
 Normuscol, 492, 493
 Normuscone, 493
 Nortricycloekasantalal, 350
 Nortricycloekasantalic acid, 350
 Nortricycloekasantalol, 350
- Ocimene**, 9, 10, 780, 787
allo-Ocimene, 11
 Ocimenol, 11
 Ocimenone, 385
 Octadecanal, 318
n-Octadecanoic acid, 581
n-Octadecyl aldehyde, 318
n-Octadecylic acid, 581
 Octanal, 306, 314, 324
 Octanoic acid, 571
 1-Octanol, 151
 3-Octanol, 152, 794
 3-Octanone, 376
 1-Octen-3-ol, 161
n-Octoic acid, 324
n-Octyl alcohol, 151
n-Octyl aldehyde, 151, 306, 314
 Octylene, 7
 Oenanthic acid, 570
 Olefins, 7
 Oleic acid, 580, 582, 591
 Olibanol, 236
 Optical rotation, 2
 Origanene, 75, 746
 "Origanol," 198
 Orthodene, 78
 Orthodonene, 99, 784
 Osazones, 812
 Osthenoole, 672
 Osthenoole methyl ether, 671
 Osthole, 659, 671, 672, 674
 Ostruthin, 659, 666, 675, 687
 Oxalic acid, 201, 384
 Oxalic acid esters, 792
 Oxalic amide hydrazide, 811
 Oxamine-oxime, 810
 Oxanilhydrazide, 814
 Oxidation, 774, 805
 Oxides, 705, 833
 1,4-Oxido-*p*-menthane, 712
 1,8-Oxido-*p*-menthane, 708
 1,4 Oxido- Δ^2 -*p*-menthene, 37
 Oximation, 809
 Oxime transformation, 782, 784
 Oximes—preparation, 809
 Oxypeucedanin, 685
 Ozone, 775
- Palladium** as catalyst, 778
 Palmitic acid, 559, 577, 579, 582
 Paraffins, 7
 Parmone, 495
- "Parsley camphor," 537
 Partheniol, 762
 Patchoulene, 288
 Patchouly alcohol, 287
 Patchouly camphor, 287
 Pelargonaldehyde, 306, 315
 Pelargonic acid, 154, 315, 378, 571, 573
 3,5,6,7,4'-Pentamethoxyflavone, 677
 Pentanal, 305
 1-Pentanol, 146
 Peonol, 525
 Perilla ketone, 483
 Perillaldehyde, 185, 342, 346
 Perillene, 700
 Perillic acid, 343
 Perillyl alcohol, 184
 Perillyl formate, 185
 1,4-Peroxido-2-*p*-menthene, 715
 Phellandral, 47, 344
 Phellandrene, 34, 399, 774, 776, 782, 784, 785, 787
 Phellandrene nitrosochloride, 783
 α -Phellandrene, 20, 41, 47
 α -Phellandrene nitrosite, 784
 β -Phellandrene, 20, 46, 778, 779, 787
 β -Phellandrene nitrosite, 785
 Phellandric acid, 345
 Phenacetonitrile, 723
 Phenacyl bromide, 828
 Phenacyl esters, 827, 828
 Phenacyl halides, 828
 β -Phenethyl isothiocyanate, 741
 Phenol ethers, 497, 499, 823
 Phenols, 497, 499, 766, 803, 823
 Phenylacetaldehyde, 293, 353
 Phenylacetamide, 724
 Phenylacetic acid, 292, 293, 597, 702, 724
 Phenylacetic acid nitrile, 723
 β -Phenylacrolein, 354
 γ -Phenylallyl alcohol, 295
 Phenylcarbamates—preparation, 799
 Phenylcarbamide, 799
 Phenylcarbinol, 290
o-Phenylenediamine, 830
 2-Phenylethanol, 292
 Phenylethyl alcohol, 292
 Phenylethyl cyanide, 724
 Phenylethylene, 14
 Phenylethyl mustard oil, 741
 1-Phenyl-3- α -furylpropane, 701
 β -Phenylglyceric acid, 646
n-Phenylhexane, 16
 Phenylhydrazine, 811, 832
 Phenylhydrazine hydrochloride, 811
 Phenylhydrazine-*p*-sulfonic acid, 813
 Phenylhydrazones—preparation, 811
 Phenylisocyanate, 799, 824
p-Phenylphenacyl bromide, 828, 830
p-Phenylphenacyl esters, 828
 3-Phenyl-1-propanol, 294
 3-Phenyl-2-propen-1-ol, 295
 β -Phenylpropionaldehyde, 356
 Phenylpropionic acid, 724
 Phenylpropionic acid nitrile, 724
 Phenylpropyl alcohol, 294

- γ -Phenyl-*n*-propyl alcohol, 294
 4-Phenylsemicarbazide, 818
 4-Phenylsemicarbazones—preparation, 818
 Phenylsemioxamazide, 820
 Phenylurethanes—preparation, 798, 799
 Phloracetophenone dimethyl ether, 543
 Phosphorous acid, 794
 Phosphorus pentachloride, 781
 "Photoanethole," 510
 Phthalates, 794, 795
 Phthalic acid esters, 794, 795
 Phthalic anhydride, 794, 795, 824
 Phthalic monoesters, 795
 Phyllocladene, 125 (*see also* Diterpene table)
 Picrates—preparation, 788, 789
 Picric acid, 788, 789, 823
 Picrocrocin, 348, 349
 Pimpinellin, 660, 686, 687
 Pinacone, 397
 3-Pinanol, 237
 Pinene, 27, 34, 43, 430, 781, 782
 Pinene nitrosochloride, 781, 782, 783
 α -Pinene, 49, 54, 62, 70, 444, 708, 775, 777, 783
 β -Pinene, 49, 62, 70, 232, 233, 347, 777
 Pinocampheol, 237, 442
 Pinocampnone, 442
 Pinocarveol, 231
 Pinocaryone, 63, 232, 233, 446, 809
 Pinol, 713
 β -Pinolene, 74
 Pinol hydrate, 58, 713
 Pinonene, 51
 Pinonic acid, 58
 Pinononic acid, 446
 Piperitenone, 416, 417
 Piperitenone hydrazone, 52
 Piperitol, 20, 211, 396
 Piperitone, 197, 211, 212, 396, 411, 810
 Piperonal, 365, 527, 807
 Piperonalacetone, 365
 Piperonylacetic acid, 527
 Piperonylic acid, 365, 366, 527, 530, 601
 Platinum as catalyst, 778
 Podocarpene, 125 (*see also* Diterpene table)
 Polarographic methods, 772
 Polymerization, 805
 Polymyrcene, 9
 Populene, 752
 Potassium dichromate—oxidation with, 775
 Potassium permanganate—oxidation with, 775
 "Prenol," 512
 Propanol, 305
 p -Propenylanisole, 508
 4-Propenylguaiaicol, 521
 Propenyl isothiocyanate, 737
 p -Propenylphenol, 512
 Propenylpyrocatecholmethylene ether, 529
 4-Propenylveratrole, 523
 Propionaldehyde, 305, 309, 807
 Propionic acid, 559, 561, 562, 565
 Propionic anhydride, 794
 β -Propylacrolein, 306, 319
 β -Propylacrylic acid, 586
 p -*n*-Propylphenol, 513
 Protocatechualdehyde dimethyl ether, 363
 Protocatechualdehyde-3-ethyl ether, 364
 Protocatechualdehyde-3-methyl ether, 361
 Prulaurasin, 721
 Prunasin, 721
 Prussic acid, 721
 Pseudo-ionone, 459
 Pseudo-irone, 468
 Pseudonitrosites, 784
 Pseudo-saccharin chloride, 803
 Pulegol, 207, 403, 718
 Pulegone, 400, 404, 405, 416, 480, 810
 Pyrazoles, 812
 Pyridinium acetohydrazide chloride, 815
 Pyruvic acid, 330, 806
 Quarternary ammonium salts of hydrazides, 814, 815
 Quinones, 547
 Raman effect, 772
 Raney nickel as catalyst, 778
 Refractive index, 2
 Regeneration of acids from alkali salts, 827
 Regeneration of alcohols from allophanates, 801
 Regeneration of alcohols from benzoic esters, 797
 Regeneration of alcohols from boric esters, 793
 Regeneration of alcohols from phthalic acid esters, 794
 Regeneration of aldehydes and ketones from hydrazones (Allen and Gates), 817, 818
 Regeneration of aldehydes and ketones from oximes, 810
 Regeneration of aldehydes and ketones from phenylhydrazones, 812
 Regeneration of aldehydes and ketones from sodium bisulfite addition products, 809
 Regeneration of aldehydes and ketones from thiosemicarbazones, 819
 Regeneration of hydrocarbons from hydrogen halides, 778, 779
 Regeneration of hydrocarbons from nitrosochlorides, 783
 Regeneration of hydrocarbons from picric esters, 789
 Regeneration of ketones from hydrazones (Girard and Sandulesco), 815, 816
 Regeneration of phenols from phenolates, 823
 Rhodinal, 336
 Rhodinic acid, 586
 Rhodinol, 178
 Rhodinolic acid, 586
 Rimuene, 125 (*see also* Diterpene table)
 Sabina glycerol, 231
 Sabinaketone, 64
 Sabinane, 53
 Sabinene, 34, 64, 202, 774, 778
 d -Sabinene glycol, 64

- Sabinenic acid, 64
 Sabinol, 230
 Saccharol, 760
 Safranal, 348
 Safrole, 526, 529
 Sagitol, 762
 Salicylaldehyde, 357
 Salicylic acid, 357, 599, 640, 642, 643
 Salicylic acid ethyl ester, 642
 Salicylic acid isoamy ester, 643
 Salicylic acid methyl ester, 640
 "Salvene," 53
 Sambunigrin, 721
 Santalal, 267
 Santalaldehyde, 267
 Santal camphor, 768
 Santalene, 112, 776
 α -Santalene, 113, 114, 115
 β -Santalene, 113, 115
 Santalenic acid, 269
 Santalic acid, 611
 Santalol, 265, 270, 794, 802
 α -Santalol, 266
 β -Santalol, 266, 267, 268, 612
 Santalone, 494
 Santene, 79, 777, 778, 779, 782, 784
 Santene hydrate, 80, 229, 776
 Santenic acid, 230
 Santenol, 80, 229
 Santenone, 229, 438
 Santenone alcohol, 229
 Santolinones, 409, 810
 Saponification, 831
 Saponification equivalent, 831
 Saponification number, 831
 Schotten-Baumann reaction, 796
 Sclareol, 125 (*see also* Diterpene table)
 Sedanolic acid, 694
 Sedanolide, 694
 Sedanonic acid, 609, 695
 Sedanonic anhydride, 609, 693
 Selinelol, 274
 Selinene, 81, 108, 274, 758, 776, 778, 779
 Selinene hydrate, 776
 Selinenol, 108, 758
 Semicarbazide, 811, 818
 Semicarbazide hydrochloride, 818
 Semicarbazido-semicarbazone, 819
 Semicarbazones—preparation, 818
 Semioxamazide, 811, 820
 Senecioic acid, 583
 Sequoiene, 753
 Sesquibeniene, 98
 Sesquibenihiol, 764
 Sesquibenihiol, 263
 Sesquicamphenol, 271
 Sesquichamene, 749
 Sesquicitronellene, 83, 259
 Sesquicryptol, 759
 Sesquigoyol, 758
 Sesquiterpenes, 81, 128, 747
 aliphatic, 83
 bicyclic, 91, 747
 monocyclic, 84
 tricyclic, 112, 749
 Sesquiterpenes of unknown constitution,
 743, 750
 Shairol, 763
 "Shojunol," 272, 760
 Silver compounds, 819
 Silver salts, 827
 Sinalbin, 742
 Sinalbin mustard oil, 742
 Sinapine bisulfate, 742
 Sinigrin, 734
 Sitosterol, 686
 Skatole, 491, 728
 Sobrerol, 58, 63, 713
 Sodium bisulfite—reaction products, 808
 Sodium dichromate—oxidation with, 775
 Sodium sulfite—reaction products, 808
 Specific gravity, 1
 Specific optical rotation, 1
 Spectrophotometric methods, 772
 Stearaldehyde, 318
 Stearic acid, 318, 577, 579, 580, 581
 Stearic aldehyde, 318
 Strychnine, 794
 Styphnates—preparation, 788
 Styphnic acid, 788, 789
 "Styracine," 296, 650
 Styrene, 14, 780
 Styrene dibromide, 781
 Styrol, 14
 Styrolene, 14
 Substituted acetohydrazides, 815
N-Substituted benzylamides, 830, 832
 Substituted hydrazine, 811, 813
 α -Substituted- β -naphthocinchoninic acids—
 preparation, 807
 p -Substituted phenacyl esters—preparation,
 828
 Substituted semicarbazide, 811, 818, 819
 Substituted semicarbazones—preparation,
 818
 5-Substituted semioxamazides, 811
 Succinic acid, 592, 688
 Succinic acid esters, 792
 Sulfates, 797
 Sulfides, 729, 833
 Sulfonamides, 788, 823
 Sulfonates, 797
 Sulfonation, 787
 Sulfones, 730
 Sulfonic acids, 730, 797
 Sulfonyl chloride, 788, 823
 Sulfur, 790
 Sulfur-containing compounds, 719
 Sulfuric acid esters, 787
 Sumbulene, 97, 778
 Sylvestrene, 32, 49, 778, 779, 782
 Sylvestrene dihydrochloride, 51, 52
 Tagetenones, 385
 Tagetone, 384
 Taiwanol, 758
 Tanacetane, 53
 Tanacetyl alcohol, 248
 Tangeretin, 677
 Tangeretol, 677

- Tasmanol, 768
 Terephthalic acid, 18, 86, 476
 Teresantallic acid, 113, 114
 Teresantalol, 257
 Terpene homologues, lower, 79
 Terpene nitrosochlorides, 783
 Terpenes, bicyclic, 49
 cyclic, 18
 monocyclic, 18
 olefinic, 7
 Terpenes of unknown constitution, 743, 745
 Terpin, 28, 187, 191, 200
 cis-Terpin, 201
 trans-Terpin, 200, 201
 1,4-Terpin, 65, 196, 202, 715
 1,8-Terpin, 200, 715
 Terpinene, 25, 28, 31, 34, 45, 65, 169, 191, 774, 776, 780, 784, 787
 α -Terpinene, 20, 24, 35, 39, 65, 775, 778, 787
 β -Terpinene, 20, 39
 γ -Terpinene, 20, 35, 39, 40
 Terpinene dihalogenides, 65, 76
 Terpinene dihydrochloride, 35, 48
 Terpinene nitrolamine, 785
 Terpinene nitrosite, 785
 α -Terpinene nitrosite, 784
 Terpinene-terpin, 34, 196, 202
 Terpinenol, 34, 196
 Terpinenol-(1), 197
 Terpinenol-(4), 198
 Terpinen-1-ol, 196, 197, 202
 Terpinen-4-ol, 65, 196, 198, 202
 Terpeneol, 20, 25, 34, 55, 169, 187, 201, 625, 776, 782, 784, 792, 802
 α -Terpeneol, 187, 188, 626
 β -Terpeneol, 187, 193
 γ -Terpeneol, 187, 195, 196
 Terpin hydrate, 25, 28, 34, 169, 173, 176, 187, 189, 201, 776, 792
 cis-Terpin hydrate, 201
 Terpinolene, 20, 24, 30, 191, 195, 775, 780, 787
 Terpinyl acetate, 626
 Terpinyl formate, 625
 Tetrabromides—preparation, 780
 1,2,4,8-Tetrabromo-*p*-menthane, 30
 Tetrachlorophthalic anhydride, 796
 n-Tetradecanoic acid, 578
 n-Tetradecyclic acid, 578
 Tetrahydroalantolactone, 692
 Δ^2 -Tetrahydro-*n*-butylidene phthalide, 609
 Δ^2 -Tetrahydro-*n*-butyl phthalide, 694
 Tetrahydrocalamene, 112
 Tetrahydrocarveol, 213
 Tetrahydrocarvone, 394, 407, 505
 Tetrahydrocostus lactone, 767
 Tetrahydrocumaldehyde, 47
 Tetrahydrocumylamine, 46
 4,5,6,7-Tetrahydro-3,6-dimethylbenzofuran, 699
 Tetrahydrofeniculin, 513
 Tetrahydroirone, 467
 1,2,3,6-Tetramethoxy-4-allylbenzene, 541
 Tetramethoxybenzoic acid, 541
 Thioalcohols, 729
 p-Thiocyanophenylhydrazine hydrochloride, 813
 Thioether, 729, 730
 Thiol compounds, 790
 Thiosemicarbazide, 819
 Thiosemicarbazido-thiosemicarbazone, 819
 Thiosemicarbazones—preparation, 819
 Thiosinamine, 735
 Thiourethanes—preparation, 738
 d- α -Thujadicarboxylic acid, 75, 428
 d- β -Thujadicarboxylic acid, 75
 Thujaketonic acid, 75, 427
 Thujane, 53
 Thujene, 34, 774
 α -Thujene, 53, 75, 202, 249, 250, 746
 β -Thujene, 53, 76
 Thujone, 248, 423
 α -Thujone, 249, 250
 Thujone series, 248
 Thujyl alcohol, 248, 426, 794
 d-Thumbelen, 747
 "Thyme camphor," 500
 "Thymene," 17, 40, 41
 Thymohydroquinone, 553, 554
 Thymol, 17, 399, 416, 417, 499, 500, 504
 Thymoquinhydrone, 554
 Thymoquinol, 553
 Thymoquinone, 501, 504, 554
 Tiglic acid, 585
 Tiglic aldehyde, 807
 α -Tolualdehyde, 353
 p-Toluene sulfonates, 797, 824
 p-Toluene sulfonic esters, 824
 p-Toluenesulfonyl chloride, 824
 p-Toluic acid, 18, 476, 483
 p-Toluidides, 829
 p-Tolylhydrazine hydrochloride, 813
 Tolyl semicarbazide, 819
 Torilene, 752
 Torilene hydrate, 752
 Torreyene, 275
 Torreyol, 275, 277
 Totarene, 125 (*see also* Diterpene table)
 2,4,6-Tribromaniline, 830
 Tricycloekasantalol, 267
 Tridecan-dicarboxylic acid, 594
 2-Tridecanone, 378
 1,2,6-Trimethoxy-4-allylbenzene, 534
 2,4,5-Trimethoxybenzaldehyde, 366
 Trimethoxybenzoic acid, 536
 3,4,5-Trimethoxybenzoic acid, 603
 2,4,6-Trimethoxybenzoylacetone, 544
 1,2,5-Trimethoxy-4-propenylbenzene, 535
 1,2,6-Trimethoxy-4-propenylbenzene, 535
 Trimethylammonium acetohydrazide chloride, 815
 3,7,7-Trimethyl-bicyclo-[2,2,1]-heptan-3-ol, 72
 2,6,6-Trimethyl-1,3-cyclohexadien-1-al, 348
 1,1,2-Trimethyl-5-cyclohexanone, 467
 1,1,2-Trimethyl-5-cyclohexanone-6-carboxylic acid, 467
 4-[2,6,6-Trimethyl-1-cyclohexen-1-yl]-3-buten-2-one, 458

- 4-[2,6,6-Trimethyl-2-cyclohexen-1-yl]-
3-buten-2-one, 458
3,7,11-Trimethyl-1,6,10-dodecatrien-3-ol,
260
3,7,11-Trimethyl-1,6,11-dodecatrien-3-ol,
260
3,7,11-Trimethyl-2,6,10-dodecatrien-1-ol,
258
3,7,11-Trimethyl-2,6,11-dodecatrien-1-ol,
258
Trimethylgallic acid, 534, 603
2,5,5-Trimethyl-1,6-heptadien-4-one, 386
2,5,5-Trimethyl-2,6-heptadien-4-one, 386
2,5,5-Trimethylheptan-4-one, 387
1,2,6-Trimethylnaphthalene, 472
 β,β,γ -Trimethyl-pimelic acid, 467
Trinitrobenzene, 788, 823
2,4,6-Trinitrobenzoyl chloride, 803
Trinitrophenol, 788, 789
2,4,6-Trinitrophenylhydrazine, 813
Trinitroresorcinol, 788, 789
Trinitrotoluene, 788, 789
p-(Triphenylmethyl)phenylisocyanate, 799
Trotylates, 788, 789
Tschugaev method, 802
"Tumerone," 450
Turmerone, 450
ar-Turmerone, 450
- Umbelliferone**, 659, 666, 677
Umbelliferone farnesyl ether, 676
Umbelliferone-4-heptyl ether, 673
Umbelliferone methyl ether, 667
Umbelliprenin, 676
Umbellularic acid, 440, 441
Umbellulone, 440, 819
Umbellulonic acid, 441
Uncincol, 755
n-Undecane, 7
Undecanoic acid, 575
Undecan-2-ol, 156
2-Undecanone, 377
1-Undecene-1-carboxylic acid, 325, 326
1-Undecen-10-ol, 166
Undecyl alcohols, secondary, 156
n-Undecylic acid, 379, 575
- Undecyl methyl ketone, 378
Ureas, 798
Urethanes—preparation, 798, 800
- n*-Valeraldehyde**, 146, 305, 310
Valeric acid, 146, 375, 559, 564, 572
Valerophenone-*o*-carboxylic acid, 609, 610
Vanillin, 361, 363, 523, 807
Vanillin methyl ether, 363
Veratraldehyde, 363
Veratric acid, 519, 520, 602
Verbanone, 445
Verbenol, 236, 444, 445
Verbenone, 236, 237, 444, 810
Verdazulene, 128
Vetivalene, 457
Vetivazulene, 128, 129, 131, 134, 457
Vetivene, 124, 776
Vetivenol, 281
Vetivenol acetate, 282
Vetiveral, 282
Vetiverol, 281
Vetiverol acetate, 282
Vetiverone, 454
Vetivone, 129, 454
Vinyl acetonitrile, 723
Vinylbenzene, 14
"Violet leaf alcohol," 164
"Violet leaf aldehyde," 164, 322
- Wave-length** absorption, 772
- Xanthates**—preparation, 802
Xanthic esters—preparation, 802
Xanthogenates—preparation, 802
Xanthotoxin, 660, 679
Xanthotoxol, 678, 684
Xanthotoxol isoamylene ether, 683
Xanthoxylin, 543
p-Xenylhydrazine, 813
p-Xenylisocyanate, 799, 825
p-Xenyl semicarbazide, 820
- Zingiberene**, 81, 87, 261, 776, 778, 782, 784
Zingiberene dihydrochloride, 262
Zingiberol, 261

