

UNIVERSAL
LIBRARY

OU_172652

UNIVERSAL
LIBRARY

BY THE SAME AUTHOR

COORDINATE GEOMETRY. Crown 8vo Thirteenth Edition. 6s The Straight Line and Circle only, 3s 6d

SOLUTIONS OF THE EXAMPLES IN THE COORDINATE GEOMETRY (with A S GOSSET-TANNER, M A) 7s 6d

AN ARITHMETIC FOR SCHOOLS. Tenth Edition Globe 8vo with or without Answers, 4s 6d Or in two Parts, with Answers, 2s 6d each The Examples alone, 3s The Answers alone, 6d

A NEW EDITION OF DR TODHUNTER'S ALGEBRA FOR BEGINNERS Globe 8vo Seventh Impression, with Corrections 3s 6d without Answers 1s 6d with Answers **KEY**, 8s 6d net

A NEW EDITION OF DR TODHUNTER'S EUCLID Globe 8vo Third Impression 4s 6d Also Book I, 1s Books I and II, 1s 6d Books I—IV, 3s

With L W GRENVILLE, M A

A SHILLING ARITHMETIC. Seventh Edition. Globe 8vo 1s. With Answers, 1s 6d

London: MACMILLAN AND CO, LIMITED.

BY THE SAME AUTHOR

A TREATISE ON ELEMENTARY DYNAMICS.

Crown 8vo Seventh Edition 7s 6d

**SOLUTIONS OF THE EXAMPLES IN THE
ELEMENTARY DYNAMICS** Crown 8vo. 7s 6d

THE ELEMENTS OF STATICS AND DYNAMICS.

Ex Fcp. 8vo

PART I ELEMENTS OF STATICS Twelfth Edition,
4s 6d

PART II ELEMENTS OF DYNAMICS Twelfth Edition,
3s 6d

The two Parts bound in one volume, 7s 6d

**SOLUTIONS OF THE EXAMPLES IN THE
ELEMENTS OF STATICS AND DYNAMICS**

Ex Fcp. 8vo. 7s 6d

**MECHANICS AND HYDROSTATICS FOR
BEGINNERS** Ex Fcp. 8vo Eleventh Edition

4s 6d

PLANE TRIGONOMETRY. Crown 8vo Ninth
Edition 7s 6d Or in two Parts

PART I UP TO AND INCLUDING THE SOLUTION OF
TRIANGLES 5s

PART II DE MOIVRE'S THEOREM AND THE HIGHER
PORTIONS 3s. 6d

**THE ELEMENTS OF TRIGONOMETRY WITH
FOUR-FIGURE LOGARITHM TABLES** Ex

Fcp 8vo Second Edition 3s 6d

**SOLUTIONS OF THE EXAMPLES IN THE
PLANE TRIGONOMETRY** Crown 8vo. 10s 6d

**SOLUTIONS OF THE EXAMPLES IN THE
ELEMENTS OF HYDROSTATICS** Ex Fcp 8vo

5s

**DYNAMICS OF A PARTICLE AND OF RIGID
BODIES** Demy 8vo 12s 6d.

Pitt Press Mathematical Series

THE ELEMENTS
OF
HYDROSTATICS.

CAMBRIDGE UNIVERSITY PRESS

London FETTER LANE, 10

C. F. CLAY, MANAGER



Edinburgh 100, PRINCES STREET

Berlin A. ASHFR AND CO

Leipzig I. A. BROCKHAUS

New York G. P. PUTNAM'S SONS

Bombay and Calcutta MACMILLAN AND Co., Ltd

All rights reserved

THE ELEMENTS
OF
HYDROSTATICS

BY

S L. LONEY, M.A.

PROFESSOR OF MATHEMATICS AT THE ROYAL HOLLOWAY COLLEGE
(UNIVERSITY OF LONDON),
SOMETIME FELLOW OF SIDNEY SUSSEX COLLEGE, CAMBRIDGE.

CAMBRIDGE:
AT THE UNIVERSITY PRESS

1911

First Edition, Oct 1900.
Second Edition, May 1904.
Reprinted 1906, 1911

PREFACE.

THE present volume is intended to be for the use of the class of students for whom my *Elements of Statics and Dynamics* was written, and may be regarded as a continuation of that book.

Hence, except in a very few articles, only a knowledge of Elementary Geometry and Algebra and of the Elements of Trigonometry is presumed.

A few formulæ relating to the mensuration of some elementary solids are prefixed to the text.

Most of the examples in the chapters are easy, with the exception of a few in Chap. IV. and some at the end of Chap. V. These latter examples, as well as a few other examples and articles marked with asterisks, should be omitted by the student on a first reading of the subject.

The Miscellaneous Examples at the end of the book are, with the exception of the first few, generally of a harder type than those in the different chapters.

Any corrections of errors, or hints for improvement of the book, will be thankfully received.

S. L. LONEY.

ROYAL HOLLOWAY COLLEGE,
EGHAM, SURREY,
July 19th, 1900.

PREFACE TO THE SECOND EDITION.

FOR the second edition the whole book has been thoroughly revised. An appendix has been added in which the position of the centre of pressure in a few cases has been found by the use of the Integral Calculus. To meet the wishes of many correspondents a book of solutions of the examples has been published.

May 16th, 1904.

CONTENTS.

CHAP		PAGE
I	FLUID PRESSURE	1
II	DENSITY AND SPECIFIC GRAVITY	13
	Mixtures	18
III	PRESSURES AT DIFFERENT POINTS OF A HOMO- GENEOUS FLUID .	23
	Whole pressure, or thrust, on an area	37
	Centre of pressure of a plane area	45
IV	RESULTANT THRUST ON ANY SURFACE	
	Resultant Vertical thrust .	48
	Resultant Horizontal thrust	55
V	EQUILIBRIUM OF FLOATING BODIES	65
	Stability of equilibrium	82
VI	ON METHODS OF FINDING THE SPECIFIC GRAVITY OF BODIES	
	The Specific Gravity Bottle	91
	The Hydrostatic Balance	95
	The Common Hydrometer	102
	Nicholson's Hydrometer	105
	The U tube Method .	110

CHAP		PAGE
VII	ON GASES	115
	The Barometer	120
	Boyle's Law	127
	Charles' Law	138
	Determination of heights by the Barometer	144
	Faulty Barometers	147
VIII	MACHINES AND INSTRUMENTS ILLUSTRATING THE PROPERTIES OF FLUIDS.	
	The Diving Bell	152
	The Common Pump	162
	Air-Pumps	174
	Bramah's Press	186
	The Siphon	187
IX.	CENTRES OF PRESSURE	190
X	ROTATING LIQUIDS	213
XI	MISCELLANEOUS PROPOSITIONS	
	Curve and Surface of Buoyancy	228
	Position of the Metacentre Stability	231
	ension of vessels containing fluids	235
	MISCELLANEOUS EXAMPLES	240
	APPENDIX	249
	ANSWERS	1-VII

SOME IMPORTANT GEOMETRICAL RESULTS

Circle. The circumference of a circle of radius $r = 2\pi r$,
and its area $= \pi r^2$

$$[\pi = 3.14159265 \dots = \frac{22}{7} \text{ nearly}]$$

Cylinder. The area of a cylinder, whose height is h and
the radius of whose base is r , $= 2\pi r h$,
and its volume $= \pi r^2 h$.

Sphere. The area of the surface of a sphere of radius r
 $= 4\pi r^2$,
and its volume $= \frac{4}{3}\pi r^3$.

The area of the zone of a sphere (*i.e.* of the surface
of the sphere cut off between two parallel planes)
 $=$ circumference of the sphere \times perpendicular dis-
tance between the planes $= 2\pi r d$

The C.G. of this zone bisects the distance between
the centres of the plane ends

The volume of a sphere included between two
parallel planes at distances x_1 and x_2 from the centre

$$= \frac{\pi}{3} (x_2 - x_1) [3a^2 - (x_1^2 + x_1 x_2 + x_2^2)]$$

Cone. The area of the curved surface of a cone, whose height is h and the radius of whose base is r ,

$$= \frac{1}{2} \text{Slant side} \times \text{Perimeter of the Base}$$

$$= \pi r \sqrt{h^2 + r^2}$$

Its volume = $\frac{1}{3}$ Height \times Area of the Base

$$= \frac{1}{3} \pi r^2 h$$

The volume of a frustum of a cone

$$= \frac{\pi}{3} d (r_1^2 + r_1 r_2 + r_2^2),$$

where r_1, r_2 are the radii of its circular ends, and d is the perpendicular distance between them

Paraboloid of revolution. This is a solid formed by the revolution of a parabola about its axis

The volume of a portion of it cut off by a plane perpendicular to its axis

= half the cylinder on the same plane base and of the same height

= $\frac{1}{2}$ area of its plane base \times its height

CHAPTER I.

FLUID PRESSURE.

1 IN Statics we have considered the equilibrium of rigid bodies, and we have defined a rigid body as one the particles of which always retain the same position with respect to one another. A rigid body possesses therefore a definite *size* and *shape*. We have pointed out that there are no such bodies in Nature, but that there are good approximations thereto.

In Hydrostatics we consider the equilibrium of such bodies as water, oils, and gases. The common distinguishing property of such bodies is the ease with which their portions can be separated from one another.

If a very thin lamina be pushed *edgeways* through water the resistance to its motion is very small, so that the force of the nature of friction, *ie* along the surface of the lamina, must be very small. There are no fluids in which this force quite vanishes, but throughout this book we shall assume that no such force exists in the fluids with which we deal. Such a hypothetical fluid is called a perfect fluid, the definition of which may be formally given as in the next article.

2. Perfect Fluid. Def. A perfect fluid is a substance such that its shape can be altered by any tangential force, however small, if applied long enough, of which portions can be easily separated from the rest of the mass, and between different portions of which there is no tangential, *i.e.* rubbing, force of the nature of friction. The difference between a perfect fluid and a water is chiefly seen in the case of the motion of the water.

For example, if we set water revolving in a cup, the frictional resistances between the water and the cup and between different portions of the water soon reduce it to rest. When water is at rest it practically is equivalent to a perfect fluid.

3. Fluids are again subdivided into two classes, *viz* **Liquids and Gases**

Liquids are substances such as water and oils. They are almost entirely incompressible. An incompressible body is one whose *total volume, i.e.* the space it occupies, cannot be increased or diminished by the application of any force, however great, although any force, however small, would change its *shape*. All liquids are really compressible under very great pressure but only to a very slight degree. For example, a pressure equal to about 200 times that of the atmosphere will only reduce the volume of a quantity of water by a one-hundredth part. This compressibility we shall neglect, and therefore define liquids as those fluids which are incompressible.

Gases, on the other hand, are fluids which can easily be made to change their total volume, *i.e.* which are, more or less easily, compressible.

If a child's air-ball be placed under the receiver of an

air-pump, from which the air has been excluded, it will increase very much in size. If the skin of the air-ball be broken, the air will expand and fill the receiver whatever be the size of the latter.

4. The definitions of a liquid and gas may be formally stated as follows,

A perfect liquid is a fluid which is absolutely incompressible

A gas is a fluid such that a finite quantity of it will, if the pressure to which it is subjected be sufficiently diminished, expand so as to fill any space however great

5 The differences between a rigid body, a liquid, and a gas may be thus expressed,

A perfectly rigid body has a definite size and a definite shape.

A perfect liquid has a definite size but no definite shape

A perfect gas has no definite size and no definite shape

6. *Viscous fluids* No fluids are perfect Many fluids, such as treacle, honey, and tar, offer a considerable resistance to forces which tend to alter their shape. Such fluids, in which the tangential action, or shearing stress, between layers in contact cannot be neglected, are called viscous fluids

7. **Pressure at a point.** Suppose a hole to be made in the side of a vessel containing fluid, and that this hole is covered by a plate which exactly fits the hole The plate will only remain at rest when some external force is applied to it, the fluid must therefore exert a force on the plate.

Also the fluid can, by definition, only exert a force perpendicular to each element of area of this plate

If the force exerted by the fluid on each equal element of area of the plate be the same, the pressure *at* any point of the plate is the force which the fluid exerts on the unit of area surrounding that point

If, however, the force exerted by the fluid on each equal element of the area of the plate be not the same, as in the case of the plate *CD*, the pressure at any point *P* of this plate is that force which the fluid would exert on a unit of area at *P*, if on this unit of area the pressure were uniform and the same as it is on an indefinitely small area at *P*.

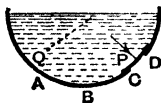

The pressure at any point within the fluid, such as *Q*, is thus obtained. Suppose an indefinitely small rigid plate placed at *Q*, so as to contain *Q*, and let its area be *a* square feet. Imagine all the fluid on one side of this plate removed and then, to keep the plate at rest, a force of *X* lbs weight must be applied to it. The pressure *at* the point *Q* is then $\frac{X}{a}$ lbs. weight per square foot.

§ The theoretical unit of pressure is, in the foot-pound system of units, one poundal per square foot. In the c. g. s. system the corresponding unit is one dyne per square centimetre.

In practice the pressure at any point of a fluid is not usually expressed in *poundals* per square *foot* but in *lbs wt.* per square *inch*. The former measure is however the best for theoretical calculation and may be easily converted into the latter.

Similarly in the c. g. s. system the practical measure of a pressure is in grammes weight per square centimetre.

It is sometimes convenient to convert a pressure expressed in the

foot-pound system into the c g s system. The relations between the units of the two systems are approximately,

$$1 \text{ inch} = 2.54 \text{ cms}, \quad 1 \text{ cm} = .3937 \text{ inch}$$

$$1 \text{ lb} = 453.6 \text{ grammes}, \quad 1 \text{ gramme} = .002204 \text{ lb.}$$

Hence a pressure of 1 lb wt. per sq inch

$$= \text{a pressure of } 453.6 \text{ grammes wt per } (2.54)^2 \text{ sq cms}$$

$$= \text{a pressure of } \frac{453.6}{(2.54)^2} \text{ grammes wt per sq cm}$$

$$= \text{a pressure of } 70.30 \text{ grammes wt per sq cm.}$$

So a pressure of 1 gramme wt per sq cm

$$= \text{a pressure of } .002204 \text{ lb wt per } (.3937)^2 \text{ sq inch}$$

$$= \text{a pressure of } \frac{.002204}{(.3937)^2} \text{ lb wt per sq inch}$$

$$= \text{a pressure of } .0142 \text{ lb wt per sq inch}$$

9 Transmission of fluid pressure. *If any pressure be applied to the surface of a fluid it is transmitted equally to all parts of the fluid*

This proposition may be proved experimentally as follows,

Let fluid be contained in a vessel of any shape, and in the vessel let there be holes *A, B, C, D*. of various sizes, which are stopped by tightly fitting pistons to which forces can be applied

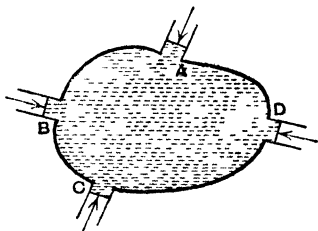

Let the areas of these pistons be *a, b, c, d*, square feet,

and let the pistons be kept in equilibrium by forces applied to them.

If an additional force $p a$ be applied to A [*i.e.* an additional pressure of p lbs. wt. per unit of area of A] *it is found* that an additional force of $p b$ lbs. wt. must be applied to B , one of $p \cdot c$ lbs. wt to C , one of $p d$ lbs. wt to D , and so on, whatever be the number of pistons. Hence an additional pressure of p , per unit of area, applied to A causes an additional pressure of p , per unit of area, on B , and of the same additional pressure per unit of area on each of the other pistons C, D, \dots

Hence the proposition is proved.

10. *The pressure at any point of a fluid at rest is the same in all directions*

This may be proved experimentally by a modification of the experiment of the last article

For suppose any one of the pistons, D , to be so arranged that it may be turned into any other position, *i.e.* so that its plane may be made parallel to the planes of either A, B , or C or be made to take any other position whatever. *It is found* that the application of an additional pressure at A , of p per unit of area, produces the same additional pressure, of p per unit of area, at D whatever be the position that D is made to occupy.

11. The foregoing proposition may be deduced from the fundamental fact that the pressure of a fluid is always perpendicular to any surface with which it is in contact.

Consider any portion of fluid in the shape of a triangular prism having its base $ACC'A'$ horizontal, and its faces $ABB'A'$ and its two triangular ends ABC and $A'B'C'$ all vertical.

Let the length AA' , the breadth AC , and the height AB be all very small and let P , Q , and R be respectively the middle points of AA' , BB' , and CC' .

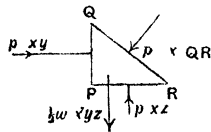
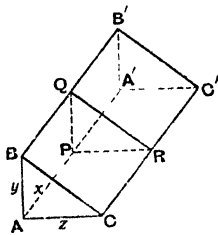

Let the lengths of AA' , AB , and AC be x , y , and z respectively.

Since the edges x and z are very small the pressure on the face $AA'C'C$ may be considered to be uniform, so that, if p be the pressure on it per unit of area, the force exerted by the fluid on it is $p \times xz$ and acts at the middle point of PR .

So if p' and p'' be the pressures per unit of area on $AA'BB'$ and $BCC'B'$ respectively, the forces on these areas are $p' \times xy$ and $p'' \times x \cdot QR$ acting at the middle points of PQ and QR respectively.

If w be the weight of the fluid per unit of volume, then, since the volume of the prism is $AA' \times \text{area } ABC$, i.e. $x \times \frac{1}{2}yz$, the weight of the fluid prism is $w \times \frac{1}{2}xyz$ and acts vertically through the centre of gravity of the triangle PQR .

This weight and the three forces exerted on the faces must be a system of forces in equilibrium, for otherwise the prism would move.

Hence, resolving the forces horizontally, we have

$$p' \times xy = p'' \times x \times QR \times \cos(90^\circ - R) = p'' \times x \times QR \times \sin R$$

$$= p'' \times x \times PQ = p'' \times xy,$$

so that $p' = p'' \dots \dots \dots (1).$

Again, resolving vertically, we have

$$p \times xz - w \times \frac{1}{2}xyz = p'' \times x \times QR \times \sin(90^\circ - R)$$

$$= p'' \times x \times QR \times \cos R = p'' \times x \times PR = p'' \times xz$$

$$\therefore p - p'' = w \times \frac{1}{2}y \dots \dots (2)$$

Now let the sides of the prism be taken indefinitely small (in which case p , p' , and p'' are the pressures at the point P in directions perpendicular respectively to PR , PQ , and QR) The quantity $w \cdot \frac{1}{2}y$ now becomes indefinitely small, and is therefore negligible

The equation (2) then becomes

$$p = p'',$$

so that

$$p = p' = p''$$

Now the direction of QR is any that we may choose, and hence the direction of p'' , which is perpendicular to QR , may be any that we please, hence the pressure of the fluid at P is the same in all directions

12. Bramah's or the Hydrostatic Press. Bramah's press affords a simple example of the transmission of fluid pressures.

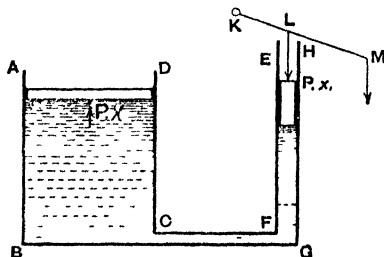

In its simplest shape it consists of two cylinders $ABCD$ and $EFGH$ both containing water, the two cylinders being connected by a tube CG . The section of one cylinder is very much greater than that of the other

In each cylinder is a closely fitting water-tight piston, the areas of the sections of which are X and x

To the smaller piston a pressure equal to P lbs wt per unit of its area is applied, so that the total force applied to it is $P x$ lbs wt

By Art 9 a pressure of P lbs wt per unit of area will be transmitted throughout the fluid, so that the thrust exerted by the fluid on the piston in the larger cylinder will be $P X$ lbs wt

This latter thrust would support on the upper surface of the piston a body whose weight is $P X$ lbs

Hence

$$\frac{\text{weight of the body supported}}{\text{force applied}} = \frac{P X}{P x} = \frac{X}{x},$$

so that the force applied becomes multiplied in the ratio of X to x , i.e. in the ratio of the areas of the two cylinders

In the above investigation the weights of the two pistons have been neglected, and also the difference between the levels of the fluid in the two cylinders

The pressure is usually applied to the smaller piston by means of a lever KLM which can turn freely about its end K which is fixed. At M the power is applied, and the point L is attached to the smaller piston by a rigid rod

Theoretically we could, by making the small piston small enough and the large piston big enough, multiply to any extent the force applied. Practically this multiplication is limited by the fact that the sides of the vessel would have to be immensely strong to support the pressures that would be put upon them

13. **Ex** If the area of the small piston in a Bramah's Press be $\frac{1}{4}$ sq. inch and that of the large piston be 2 square feet, what weight would be supported by the application of 20 lbs. weight to the smaller piston?

The pressure at each point of the fluid in contact with the small piston is $20 \div \frac{1}{4}$, i.e. 60 lbs. wt. per sq. inch.

This pressure is (by Art 9) applied to each square inch of the larger piston whose area is 288 sq ins

Hence the total thrust exerted on the large piston is 288×60 , i.e. 17280 lbs wt, i.e. $7\frac{2}{3}$ tons wt

A weight of $7\frac{2}{3}$ tons would therefore be supported by the larger piston

14. Bramah's Press forms a good example of the Principle of Work as enunciated in *Statics*, Art. 200

For, since the decrease in the volume of the water in the small cylinder is equal to the increase of the water in the large cylinder, it follows that

$$X Y = x y,$$

where Y and y are the respective distances through which the large and small pistons move

Hence
$$\frac{X}{x} = \frac{y}{Y}$$

$$\therefore \frac{\text{force exerted by large piston}}{\text{force exerted by small piston}} = \frac{X}{x} = \frac{y}{Y}.$$

$$\begin{aligned} \therefore \text{force exerted by large piston} \times Y \\ = \text{force exerted by small piston} \times y, \end{aligned}$$

i.e. the work done by the large piston is the same as that done on the small piston

Hence the Principle of Work holds.

15. **Safety Valve.** The safety valve affords another example of the pressure exerted by fluids. In the case of a boiler with steam inside it, the pressure of the steam

might often become too great for the strength of the boiler, and there would be danger of its bursting. The use of the safety valve is to allow the steam to escape when the pressure is greater than what is considered to be safe.

In one of its forms it consists of a circular hole D in the side of the boiler into which there fits a plug. This plug is attached at B to an arm ABC , one end of which,

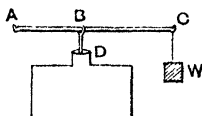

A , is jointed to a fixed part of the machine. The arm ABC can turn about A and at the other end C can be attached whatever weights are desired.

It is clear that the pressure of the steam and the weight at C tend to turn the arm in different directions. When the moment of the pressure of the steam about A is greater than the moment of the weight at C , the plug D will rise and allow steam to escape, thus reducing the pressure.

In other valves there is no lever ABC and the plug is replaced by a circular valve, which is weighted and which can turn about a point in its circumference.

Ex. The arms of the lever of a safety valve are 1 inch and 18 inches and at the end of the longer arm is hung a weight of 20 lbs. If the area of the valve be $1\frac{1}{2}$ square inches, what is the maximum pressure of the steam which is allowed?

If p lbs. wt per square inch be the required pressure, the total force exerted on the valve by the steam = $p \times \frac{3}{2}$ lbs. wt.

When the valve is just about to rise the two forces $\frac{3p}{2}$ and 20 lbs wt balance at the ends of arms 1 and 18 inches.

Hence
$$\frac{3p}{2} \times 1 = 20 \times 18.$$

$$\therefore p = 240 \text{ lbs. wt.}$$

EXAMPLES. I.

1. In a Bramah's Press the diameters of the large and small piston are respectively $2\frac{1}{2}$ decimetres and 2 centimetres, a kilogram is placed on the top of the small piston, find the mass which it will support on the large piston.

2. In a Bramah's Press the area of the larger piston is 100 square inches and that of the smaller one is $\frac{1}{4}$ square inch, find the force that must be applied to the latter so that the former may lift 1 ton

3. A water cistern, which is full of water and closed, can just bear a pressure of 1500 lbs wt per square foot without bursting

If a pipe, whose section is $\frac{1}{4}$ square inch, communicate with it and be filled with water, find the greatest weight that can safely be placed on a piston fitting this pipe

4. In a Bramah's Press if a thrust of 1 ton wt be produced by a power equal to 5 lbs wt and the diameters of the pistons be in the ratio of 8 to 1, find the ratio of the lengths of the arms of the lever employed to work the piston

5. In a hydraulic press the radii of the cylinders are 3 inches and 6 feet respectively. The power is applied at the end of a lever whose length is 2 feet, the piston being attached at a distance of 2 inches from the fulcrum. If a body weighing 10 tons be placed upon the large piston, find the power that must be applied to the lever

If the materials of the press will only bear a pressure of 150 lbs wt to the square inch, find what is the greatest weight that can be lifted

6. A vessel full of water is fitted with a tight cork. How is it that a slight blow on the cork may be sufficient to break the vessel?

7. The arms of the lever of a safety valve are of lengths 2 inches and 2 feet, and at the end of the longer arm is suspended a weight of 12 lbs. If the area of the valve be 1 square inch, what is the pressure of the steam in the boiler when the valve is raised?

8. Find the pressure of steam in a boiler when it just sufficient to raise a circular safety-valve which has a diameter of $\frac{1}{2}$ inch and is loaded so as to weigh $\frac{1}{2}$ lb

9. The weight of the safety-valve of a steam boiler is 16 lbs and its section is $\frac{1}{2}$ of a square inch. Find the pressure of the steam in the boiler that will just lift the safety-valve.

CHAPTER II.

DENSITY AND SPECIFIC GRAVITY.

16. Density Def The density of a homogeneous body is the mass of a unit volume of the body

The mass of a cubic foot of pure water at 4°C is found to be about 1000 ozs, *i e* $62\frac{1}{2}$ lbs Hence the density of water is $62\frac{1}{2}$ lbs per cubic foot

A gramme is the mass of the water at 4°C which would fill a cubic centimetre Hence the density of water at 4°C is one gramme per cubic centimetre

The reason why a certain temperature is taken when we define a gramme is that the volume of a given mass of water alters with the temperature of the water If we take a given mass (say 1 lb) of water and cool it gradually from the boiling point 100°C [*i e* 212°F], it is found to occupy less and less space until the temperature is reduced to 4°C [about 39.2°F] If the temperature be continually lowered still further the volume occupied by the pound of water is now found to *increase* until the water arrives at its freezing point Hence the pound of water occupies less space at 4°C . than at any other temperature,

i e there is more water in a given volume at 4°C than at any other temperature,

i e. the density is greatest at 4°C

The mass of a cubic foot of mercury is found to be 13.596 times that of a cubic foot of water. Hence the

density of mercury is nearly $13.596 \times 62\frac{1}{2}$ lbs per cubic foot.

If we use centimetre gramme units the density of mercury is 13 596 grammes per cubic centimetre.

17. It is sometimes convenient to be able to convert densities expressed in the foot-pound system into the c.g.s. system, and conversely

As in Art. 8 we have

$$1 \text{ foot} = 30.48 \text{ centimetres, } 1 \text{ cm.} = .0328 \text{ ft}$$

$$1 \text{ lb} = 453.6 \text{ grammes, } 1 \text{ gramme} = 0.002204 \text{ lb}$$

Hence a density of 1 lb. per cubic foot

$$= \text{a density of } 453.6 \text{ grammes per } (30.48)^3 \text{ cubic cms}$$

$$= \text{a density of } \frac{453.6}{(30.48)^3} \text{ grammes per cub. cm.}$$

$$= 0.1602 \text{ grammes per cub. cm approx}$$

So a density of 1 gramme per cub. cm

$$= \text{a density of } 0.002204 \text{ lb per } (.0328)^3 \text{ cub. ft}$$

$$= \text{a density of } \frac{.002204}{(.0328)^3} \text{ lbs per cub. ft}$$

$$= \text{a density of } 62.4 \text{ lbs per cub. ft approx.}$$

18. If W be the weight of a given substance in pounds, ρ its density in lbs. per cubic foot, V its volume in cubic feet, and g the acceleration due to gravity measured in foot-second units, then $W = g\rho V$

For if M be the mass of the substance, we have by *Dynamics*, Art 68,

$$W = Mg$$

Also $M =$ mass of V cubic feet of the substance

$$= V \times \text{mass of one cubic foot}$$

$$= V \cdot \rho.$$

$$\therefore W = g\rho V.$$

A similar relation is true if W be expressed in dynes, ρ in grammes per cubic centimetre, V in cubic centimetres, and g in centimetre-second units

19. Specific Gravity. Def. *The specific gravity of a given substance is the ratio of the weight of any volume of the substance to the weight of an equal volume of the standard substance.*

Thus a specific gravity is always a number

[N B The term specific gravity is generally shortened to sp gr.]

For convenience the standard substance usually taken is pure water at a temperature of 4° C.

Since the weight of a cubic foot of mercury is found to be 13·596 times that of a cubic foot of water, the specific gravity of mercury is the number 13 596

When we say that the specific gravity of gold is 19 25, water is the standard substance, and hence we mean that a cubic foot of gold would weigh 19 25 times as much as a cubic foot of water,

i.e. about $19\ 25 \times 62\frac{1}{2}$ lbs.,

i.e. about 1203 $\frac{1}{2}$ lbs wt

Since the weights of bodies are proportional to their masses, the specific gravity of a substance may be defined as the ratio of the *mass* of any volume of the substance to the *mass* of an equal volume of the standard substance

The specific gravity of a substance is also often called its "relative weight" or its "relative density."

20 Specific gravity of gases. Since gases are very light compared with water, their sp gr. is often referred to air at a temperature of 0° C. and with the mercury-barometer [Art. 96] standing at a height of 760 millimetres, *i.e.* about 30 inches. The mass of a cubic foot of air under these conditions is about 1 25 ozs.

21. The following table gives the approximate specific gravities of some important substances.

Solids.

Platinum 21 5	Glass (Crown) 2·5 to 2·7.
Gold 19 25	„ (Flint) 3 0 to 3 5.
Lead 11 3	Ivory 1 9
Silver 10 5.	Oak 7 to 1·0.
Copper 8 9.	Cedar 6
Brass 8 4	Poplar 4.
Iron 7 8	Cork 24.

Liquids at 0° C.

Mercury 13 596	Milk 1 03
Sulphuric Acid 1 85	Alcohol 8.
Glycerine 1 27	Ether 73.

22. If W be the weight of a volume V of a body whose specific gravity is s , and w be the weight of a unit volume of the standard substance, then $W = V \cdot s \cdot w$

$$\text{For } s = \frac{\text{weight of a unit volume of the body}}{\text{weight of a unit volume of the standard substance}}$$

$$\therefore \text{wt of unit volume of the body} = s \cdot w$$

$$\therefore \text{wt of } V \text{ units of volume of the body} = V \cdot s \cdot w.$$

$$\therefore W = V \cdot s \cdot w$$

Cor. If the units used be the c.g.s system, then $w = \text{weight of one cubic cm. of water} = 1 \text{ gramme.}$

$\therefore W = V \cdot s$ grammes, that is, in the c.g.s. system the weight of a body expressed in grammes is equal to its specific gravity multiplied by its volume in cubic cms.

Ex. If a cubic foot of water weigh $62\frac{1}{2}$ lbs, what is the weight of 4 cub. yards of copper, the sp gr of copper being 8.8?

Here $w = 62\frac{1}{2}$ lbs. wt., $V = 108$ cub. ft., and $s = 8.8$.

$$\begin{aligned} \therefore W &= 108 \times 8.8 \times 62\frac{1}{2} = 59400 \text{ lbs wt} \\ &= 26\frac{3}{8} \text{ tons wt} \end{aligned}$$

23. The word "intrinsic weight" is sometimes used. The intrinsic weight of a substance is the weight of a unit volume of the substance. Thus, as in the previous article, the intrinsic weight = $s w$, and then $W = V \times$ the intrinsic weight of the substance

EXAMPLES. II.

[In all examples it may be assumed that the weight of a cubic foot of water is $62\frac{1}{2}$ lbs.]

1. What is the weight of a cubic foot of iron (sp gr = 9)?
2. The sp gr of brass is 8, what is its density in ounces per cubic inch, given that the density of water is 1000 ozs per cubic foot?
3. A gallon of water weighs 10 lbs and the sp gr of mercury is 13.598. What is the weight of a gallon of mercury?
4. Find the weight of a litre (a cub. decimetre or 1000 cub. cms) of mercury at the standard temperature when its sp gr is 13.6.
5. If 13 cub. ins. of gold weigh as much as $96\frac{1}{4}$ cub. ins. of quartz and the sp. gr. of gold be 19.25, find that of quartz.
6. The sp. gr. of gold being 19.25, how many cubic feet of gold will weigh a ton?
7. The sp. gr. of cast copper is 8.88 and that of copper wire is 8.79. What change of volume does a kilogramme of cast copper undergo in being drawn into wire?
8. If a foot length of iron pipe weigh 64.4 lbs. when the diameter of the bore is 4 ins. and the thickness of the metal is $1\frac{1}{4}$ ins., what is the sp. gr. of the iron?
9. A rod 18 ins long and of uniform cross-section weighs 8 ozs. and its sp gr is 8.8. What is the area of its cross section?

10. A sphere, of radius 45 cms., weighs 2376 kilogrammes; what is its density? [$\pi = \frac{22}{7}$]

11. What volume of copper (sp gr. = 8.9) weighs 139.0625 kilogrammes?

12. The mass of 9 cubic feet of metal is 4900 lbs., find its density in grammes per cubic centimetre.

13. The mass of 45 cubic metres of wood is 36000 kilogrammes; find its density in lbs per cubic foot

14. The sp gr. of an imperfect metal casting is found to be 6.3, if the proper sp. gr. of the casting is 7.5, how much per cent. of it is not occupied by metal?

24. Specific gravities and densities of mixtures.

To find the specific gravity of a mixture of given volumes of different substances whose specific gravities are given

Let V_1, V_2, V_3 be the volumes of the different substances, and s_1, s_2, s_3 . their specific gravities, so that the weights of the different substances are, by Art. 22,

$$V_1 s_1 w, \quad V_2 s_2 w, \quad V_3 s_3 w, \quad \dots$$

where w is the weight of a unit volume of the standard substance.

(1) When the substances are mixed let there be no diminution of volume, so that the final volume is

$$V_1 + V_2 + V_3 + \dots$$

Let \bar{s} be the new specific gravity, so that the sum of the weights of the substances is

$$(V_1 + V_2 + V_3 + \dots) \bar{s} w.$$

Since the sum of the weights must be unaltered, we have

$$[V_1 + V_2 + V_3 + \dots] \bar{s} w = V_1 s_1 w + V_2 s_2 w + V_3 s_3 w + \dots$$

$$\therefore \bar{s} = \frac{V_1 s_1 + V_2 s_2 + V_3 s_3 + \dots}{V_1 + V_2 + V_3 + \dots}.$$

(2) When there is a loss of volume on mixing the substances together, as sometimes happens, let the final volume be n times the sum of the original volumes, where n is a proper fraction

In this case we have

$$n [V_1 + V_2 + V_3 + \dots] \bar{s}w = V_1 s_1 w + V_2 s_2 w + \dots,$$

so that
$$\bar{s} = \frac{V_1 s_1 + V_2 s_2 + \dots}{n (V_1 + V_2 + \dots)}.$$

Similar formulæ will hold if the densities instead of the specific gravities be given. For the original specific gravities $s_1, s_2,$ we must substitute the original densities $\rho_1, \rho_2,$ and for the final specific gravity \bar{s} we must substitute the final density $\bar{\rho}$

Ex *Volumes proportional to the numbers 1, 2 and 3 of three liquids whose sp grs are proportional to 1 2, 1 4 and 1 6 are mixed together, find the sp. gr of the mixture*

Let the volumes of the liquids be $x, 2x,$ and $3x$

Their weights are therefore

$$wx \times 1 2, 2wx \times 1 4, \text{ and } 3wx \times 1 6$$

Also, if \bar{s} be the sp gr of the mixture, the total weight is

$$w\bar{s} (x + 2x + 3x)$$

Equating these two, we have

$$6w\bar{s} x = wx \times 8 8$$

$$\therefore \bar{s} = \frac{1}{6} \times 8 8 = 1 46$$

25. *To find the specific gravity of a mixture of given weights of different substances whose specific gravities are given.*

Let W_1, W_2, \dots be the weights of the given substances, s_1, s_2, \dots their specific gravities, and w the weight of a unit volume of the standard substance.

By Art. 22, the volumes of the different substances are

$$\frac{W_1}{s_1 w}, \frac{W_2}{s_2 w}, \dots$$

If no loss of volume takes place when the mixture is made, the new volume is $\frac{W_1}{s_1 w} + \frac{W_2}{s_2 w} + \dots$.

Hence, if \bar{s} be the new specific gravity, the sum of the weights of the substances is, by Art 22,

$$\left(\frac{W_1}{s_1 w} + \frac{W_2}{s_2 w} + \dots \right) \bar{s} w,$$

i e.

$$\left(\frac{W_1}{s_1} + \frac{W_2}{s_2} + \dots \right) \bar{s}$$

Hence, since the sum of the weights necessarily remains the same, we have

$$\left(\frac{W_1}{s_1} + \frac{W_2}{s_2} + \dots \right) \bar{s} = W_1 + W_2 + \dots,$$

so that

$$\bar{s} = \frac{W_1 + W_2 + \dots}{\frac{W_1}{s_1} + \frac{W_2}{s_2} + \dots}.$$

If there be a contraction of volume so that the final volume is n times the sum of the original volumes, then, as in the last article, we have

$$\bar{s} = \frac{W_1 + W_2 + \dots}{n \left[\frac{W_1}{s_1} + \frac{W_2}{s_2} + \dots \right]}.$$

A similar formula gives the final density in terms of the weights and the original densities.

Ex 10 lbs wt. of a liquid, of sp. gr 1.25, is mixed with 6 lbs wt. of a liquid of sp. gr. 1.15 What is the sp. gr. of the mixture?

If w be the weight of a cubic foot of water the respective volumes of the two fluids are, by Art. 22,

$$\frac{10}{125 \times w} \text{ and } 1 \frac{6}{15 \times w} \text{ cub ft.}$$

Hence, if \bar{s} be the required sp gr., we have

$$\left(\frac{10}{125 \times w} + \frac{6}{15 \times w} \right) \bar{s} w = \text{total weight} = 10 + 6.$$

$$\therefore \bar{s} \left[8 + \frac{120}{23} \right] = 16.$$

$$\therefore s = \frac{16 \times 23}{304} = \frac{23}{19} = 1.2105 \dots$$

EXAMPLES. III.

1. The sp gr of a liquid being 8, in what proportion must water be mixed with it to give a liquid of sp gr 85?

2. 12 lbs wt of a liquid, of sp gr 11, is mixed with 20 lbs of a liquid, of sp gr 9, what is the sp gr of the mixture?

3. If a volume of 39 cub cms. of a liquid of density 9 grammes per cub. cm be mixed with 51 cub cms of a liquid of density 75 grammes per cub cm, what is the density of the resulting mixture?

4. How much water must be added to 27 ozs of a salt solution whose sp gr is 1.08 so that the sp gr of the mixture may be 1.05?

5. What is the volume of a mass of wood of sp. gr 5 so that when attached to 500 ozs. of iron of sp gr. 7, the mean sp. gr of the whole may be unity?

6. An alloy is composed of zinc and copper whose specific gravities are respectively 7 and 8.9, if the alloy is of volume 452 cub cms and mass 3373 grammes, what is the volume of each component of the alloy?

7. Three equal vessels, A , B , and C , are half full of liquids of densities ρ_1 , ρ_2 , and ρ_3 respectively. If now B be filled from A and then C from B , find the density of the liquid now contained in C , the liquids being supposed to mix completely.

8. When equal volumes of two substances are mixed the sp gr of the mixture is 4, when equal weights of the same substances are mixed the sp gr of the mixture is 3. Find the sp. gr. of the substances

9. When equal volumes of alcohol (sp gr = .8) and distilled water are mixed together the volume of the mixture (after it has returned to its original temperature) is found to fall short of the sum of the volumes of its constituents by 4 per cent. Find the sp. gr. of the mixture.

10. A mixture is made of 7 cub. cms. of sulphuric acid (sp gr. = 1.843) and 3 cub cms of distilled water and its sp. gr when cold is found to be 1.615. What contraction has taken place?

11. The mixture of a quantity of a liquid A with n lbs. of B has a sp. gr s , with $2n$ lbs of B a sp gr s' , with $3n$ lbs of B a sp gr. s'' , find equations to determine the specific gravities, s_1 and s_2 , of A and B .

CHAPTER III.

PRESSURES AT DIFFERENT POINTS OF A HOMOGENEOUS
FLUID WHICH IS AT REST.

26. A FLUID is said to be homogeneous when, if any equal volumes, however small, be taken from different portions of the fluid, the masses of all these equal volumes are equal

27. *The pressure of a heavy homogeneous fluid at all points in the same horizontal plane is the same*

Take two points of a fluid, P and Q , which are in the same horizontal plane.

Join PQ , and consider a small portion of the fluid whose shape is a very thin cylinder having PQ as its axis.

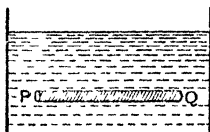

The only forces acting on this cylinder in the direction of the axis PQ are the two pressures on the plane ends of the cylinder.

[For all the other forces acting on this cylinder are perpendicular to PQ , and therefore have no effect in the direction PQ .]

Hence, for equilibrium, these pressures must be equal and opposite

Let the plane ends of this cylinder be taken very small, so that the pressures on them per unit of area may be taken to be constant and equal respectively to the pressures at P and Q

Hence pressure at $P \times$ area of the plane end at P
 $=$ pressure at $Q \times$ area of the plane end at Q .

\therefore pressure at $P =$ pressure at Q

28. *To find the pressure at any given depth of a heavy homogeneous liquid, the pressure of the atmosphere being neglected*

Take any point P in the liquid, and draw a vertical line PA to meet the surface of the liquid in the point A

Consider a very thin cylinder of liquid whose axis is PA . This cylinder is in equilibrium under the forces which act upon it

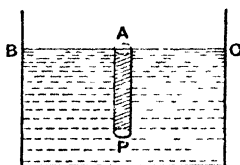

The only vertical forces acting on it are its weight and the force exerted by the rest of the fluid upon the plane face at P

If a be the area of the plane face and x the depth AP , the weight of this small cylinder of liquid is $w \times a \times x$, where w is the intrinsic weight of the liquid.

Also the vertical force exerted on the plane end at P is $p \times a$, where p is the pressure at P per unit of area.

$$\begin{aligned} \text{Hence} \quad p a &= w a x \\ \therefore p &= w \cdot x \end{aligned}$$

Cor. Since the pressure at any point of a liquid depends only on the depth of the point, the necessary strength of the embankment of a reservoir depends *only* on the depth of the water and not at all on the *area of the surface* of the water

29 In the above expression for the pressure care must be taken as to the units in which the quantities are measured. If British units be used, x is the depth in feet, w is the weight of a cubic foot of the liquid, and p is the pressure expressed in lbs wt per square foot

If c g s units be used, x is the depth in centimetres, w is the weight of a cubic centimetre of the liquid, and p is the pressure expressed in grammes weight per square centimetre. If the liquid be water, it should be noted that w equals the weight of one gramme [Art 16.]

30. The theorem of Art. 28 may be verified experimentally. PQ is a hollow cylinder one end of which Q is closed by a thin light flat disc which fits tightly against this end.

The cylinder and disc are then pushed into the water, the cylinder remaining always in a vertical position. The disc does not fall, being supported by the pressure of the water

Into the upper end of the cylinder water is now poured very slowly and carefully. The disc is not found to fall until the water inside the cylinder stands at very nearly

the same height as it does outside, and, the less the weight of the disc, the more nearly are these heights the same.

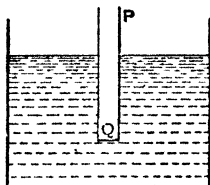

If h be the depth of the point Q , and A be the area of the cylinder, the pressure on Q of the external fluid must balance the weight of the internal fluid, and this weight is $A \cdot h \times w$, *i.e.* $A \times wh$. Hence the external pressure at Q per unit of area must be wh

31. In Art 28 we have neglected the pressure of the atmosphere, *i.e.* we have assumed the pressure at A to be zero.

If this pressure be taken into consideration and denoted by Π , the equation of that article should be

$$p \ a = w \ a \cdot x + \Pi \ a,$$

i.e.
$$p = wx + \Pi$$

The pressure of the atmosphere is roughly equal to about 15 lbs. wt. per sq. inch [This pressure is often called "15 lbs. per square inch."]

Instead of giving the atmospheric pressure in lbs. wt per sq. inch it is often expressed by saying that it is the same as that of a column of water, or mercury, of a given height.

This, as we shall see in Chapter VII., is the same as telling us the height of the barometer made of that liquid

For example, if we are told that the height of the water-barometer is 34 feet, we know that the pressure of the atmosphere *per square foot* = weight of a column of water whose base is a square foot and whose height is 34 feet

$$\begin{aligned} &= \text{wt of } 34 \text{ cubic feet of water} \\ &= 34 \times 62\frac{1}{2} \text{ lbs. wt} \end{aligned}$$

Hence the pressure of the atmosphere per square inch

$$\begin{aligned} &= \frac{34 \times 62\frac{1}{2}}{12^2} \text{ lbs wt} \\ &= 14\frac{109}{144} \text{ lbs. wt.} \end{aligned}$$

The same fact is often expressed by saying that the pressure is that due to a "head" of 34 feet of water

An imaginary horizontal surface at a height above *BC* [Fig, Art 28] equal to the height of the water-barometer is often called the Effective Surface. The pressure at any point in water is then proportional to the depth below the Effective Surface

Ex 1 Find the pressure in water at a depth of 222 feet, the height of the water-barometer being 34 feet

If *w* be the weight of a cubic foot of water, we have

$$\Pi = w \cdot 34 \text{ lbs wt}$$

$$\begin{aligned} \therefore p &= \Pi + wh = w \cdot 34 + w \cdot 222 = 256 w \text{ per sq ft} \\ &= 256 \times 62\frac{1}{2} \text{ lbs wt per sq. ft} \\ &= \frac{16000}{144} \text{ lbs. wt. per sq inch} \\ &= 111\frac{1}{3} \text{ lbs wt per sq inch} \end{aligned}$$

Ex. 2 Find the pressure at a depth of 10 metres in water, the pressure of the atmosphere being equal to that of a head of mercury (*sp gr* = 13.6) of 760 millimetres

Here Π = pressure of the atmosphere per sq cm. = wt. of a column of 76 cms height = wt of 76 cub cms. of mercury = 76×13.6 grammes.

$\therefore p = \Pi + w \times 1000 = (76 \times 13.6 + 1000)$ grammes wt. per sq. cm., since *w* = weight of 1 cub cm of water = 1 gramme

$$\therefore p = 2033.6 \text{ grammes per sq. cm}$$

32. *The surface of a heavy liquid at rest is horizontal.*

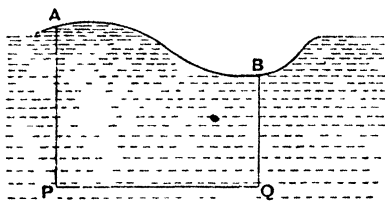

Take any two points, P and Q , of the liquid which are in the same horizontal plane. Draw vertical lines PA and QB to meet the surface of the liquid in A and B .

Then, by Art 27, the pressure at P
 = the pressure at Q

Hence, by Art 31, $\Pi + w PA = \Pi + w QB$.

$$\therefore PA = QB$$

Hence, since PQ is horizontal, the line AB must be horizontal also

Since P and Q are *any* two points in the same horizontal line, it follows that *any* line AB drawn in the surface of the liquid must be horizontal also

Hence the surface is a horizontal plane

33. In the preceding proofs we have assumed that the weights of different portions of the fluids act vertically downwards in parallel directions. This assumption, as was pointed out in *Statics*, Art. 96, is only true when the body spoken of is small compared with the size of the earth.

If the body be comparable with the earth in size we cannot neglect the fact that, strictly speaking, the weights of the different portions of the body do not act in parallel

lines, but along lines directed toward the centre of the earth.

The theorem of the preceding article would not therefore apply to the surface of the sea, even if the latter were entirely at rest

34. The proposition of Art 27 can be proved for the case when it is impossible to connect the two points by a horizontal line which lies wholly within the fluid

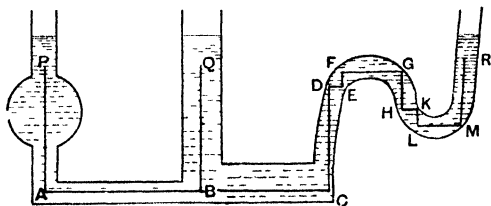

For the two points P and Q can be connected by vertical and horizontal lines such as PA , AB , and BQ in the figure

We then have

$$\text{pressure at } A = \text{pressure at } B$$

$$\text{But pressure at } A = \text{pressure at } P + w AP,$$

$$\text{and pressure at } B = \text{pressure at } Q + w BQ$$

But, since P and Q are in the same horizontal plane,

$$AP = BQ$$

Hence the pressure at $P = \text{pressure at } Q$.

Similarly the proposition is true for any two points at the same level.

Thus, if R be at the same level as P , and vertical and

horizontal lines be drawn as in the figure, we have pressure

$$\begin{aligned} \text{at } R &= \text{pressure at } P + w \cdot PA - w \cdot CD - w \cdot FF \\ &\quad + w \cdot GH + w \cdot KL - w \cdot MR \\ &= \text{pressure at } P, \end{aligned}$$

since $CD + EF + MR = AP + HG + LK$

Hence the surface of the fluid will always stand at the same level provided the fluid be at rest

For example, the level of the tea inside a teapot and in the spout of the teapot is always at the same height

35. The statement that the surface of a liquid at rest is a horizontal plane is sometimes expressed in the form "water finds its own level"

It is this property of a liquid which enables water to be supplied to a town. A reservoir is constructed on some elevation which is higher than any part of the district to be supplied. Main pipes starting from the reservoir are laid along the chief roads, and smaller pipes branch off from these mains to the houses to be supplied. If the whole of the water in the reservoir and pipes be at rest, the surface of the water would, if it were possible, be at the same level in the pipes as it is in the reservoir. The mains and side-pipes may rise and fall, in whatever manner is convenient, provided that no portion of such main pipe is higher than the surface of the water in the reservoir.

36. It follows from the previous article that the pressure at any point of the base of a vessel containing liquid does not depend on the shape of the vessel, but only on the depth of the liquid

Thus suppose we have four vessels as in the figure, of

different shapes, but of the same height, and let them all be filled with water.

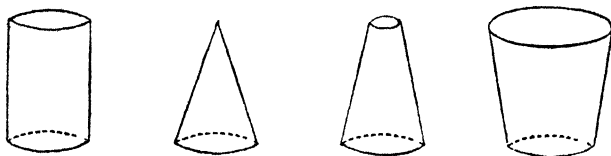

By Art 27, the pressure at any point of the base is the same as at its centre, and the pressure here is, by Art. 28, just that due to the vertical height of the surface of the fluid above it

The principle that the pressure at any point is that due to the depth of the point below the surface of the liquid is also exemplified by the **Hydrostatic Bellows**. A leather bellows *A* has attached to it a tube *BC*, and on the face of the bellows is placed a weight *W* Water is poured into

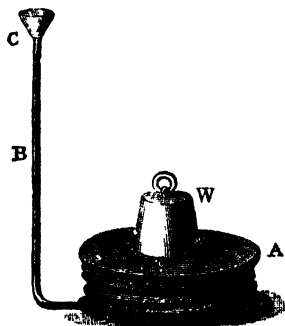

the tube at *C* and the weight is raised Let *X* be the area of the portion of the upper board of the bellows in contact

with the water. If the height of the top of the water in the tube above A be x , there is a pressure xw exerted on each unit of area of X . [Art 28] Thus the total force on the upper face of the bellows is Xxw . If this be greater than the weight W , the latter is raised, the level of the water in the tube is thus diminished until the quantity Xxw is just equal to W , and then there is equilibrium.

This experiment is sometimes known as the Hydrostatic Paradox

37. *To find the pressure at any given depth in the lower of two given heavy homogeneous liquids, which do not mix*

Let w and w' be the specific weights of the lower and upper liquids respectively

Let P be any point in the lower liquid. [Fig, Art. 38.] Draw a vertical line to meet the surface of separation of the two liquids in A , and the upper surface of the upper liquid in A'

As in Art 28, consider a very thin cylinder whose axis is PAA' and the area of whose cross-section is a

Then, if p be the pressure at P per unit of area, we have

$$\begin{aligned} p \cdot a &= w \cdot a \cdot PA + a \times \text{the pressure at } A \\ &= w \cdot a \cdot PA + a \times w' \cdot AA' \\ \therefore p &= w \cdot PA + w' \cdot AA' = w \cdot h + w' \cdot h', \end{aligned}$$

where h' is the thickness of the upper stratum and h is the depth of the point considered below the common surface of the two liquids.

38. *The common surface of two heavy homogeneous liquids, which do not mix, is a horizontal plane.*

COMMON SURFACE OF TWO HEAVY LIQUIDS. 33

Let P and Q be any two points in the lower liquid, the straight line joining which is horizontal

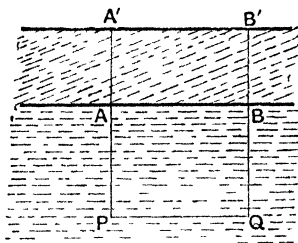

Let w, w' be as in the last article Draw PAA', QBB' vertically to meet the common surface in A and B , and the surface of the upper liquid in A' and B' .

Since PQ is horizontal,

the pressure at P = the pressure at Q (Art 27)

$$\therefore w \cdot PA + w' \cdot AA' = w \cdot QB + w' \cdot BB' \quad (\text{Art 37})$$

$$w(PA' - AA') + w' \cdot AA' = w(QB' - BB') + w' \cdot BB' \quad (1).$$

But PQ is horizontal, and $A'B'$ is horizontal, by Art 32,

$$\therefore PA' = QB'.$$

$$\therefore (1) \text{ becomes } (w' - w) \cdot AA' = (w' - w) \cdot BB'.$$

$$\therefore AA' = BB'.$$

$$\therefore AB \text{ is parallel to } A'B',$$

and is therefore horizontal

Hence the straight line joining any two points on the common surface is horizontal, and thus the common surface is horizontal.

EXAMPLES IV.

1. If a cubic foot of water weigh 1000 ozs, what is the pressure per sq inch at the depth of a mile below the surface of the water?

2. Find the depth in water at which the pressure is 100 lbs. wt per sq inch, assuming the atmospheric pressure to be 15 lbs wt per sq. inch.

3. The sp gr of a certain fluid is 1.56 and the pressure at a point in the fluid is 12090 ozs, find the depth of the point, a foot being the unit of length

4. The pressure in the water-pipe at the basement of a building is 34 lbs wt to the sq inch and at the third floor it is 18 lbs. wt to the sq inch. Find the height of this floor above the basement

5. If the atmospheric pressure be 14 lbs wt per sq in and the sp gr of air be .00125, find the height of a column of air of the same uniform density which will produce the same pressure as the actual atmosphere produces

6. If the force exerted by the atmosphere on a plane area be equal to that of a column of water 34 feet high, find the force exerted by the atmosphere on one side of a window-pane 16 inches high and one foot wide

7. The pressure at the bottom of a well is four times that at a depth of 2 feet; what is the depth of the well if the pressure of the atmosphere be equivalent to that of 30 feet of water?

8. If the height of the water-barometer be 34 ft, find the depth of a point below the surface of water such that the pressure at it may be twice the pressure at a point 10 ft below the surface

9. If the pressure at a point 5 feet below the surface of a lake be one-half of the pressure at a point 44 feet below the surface, what must be the atmospheric pressure in lbs wt. per sq inch?

10. Find the pressure in tons per sq yard at a depth of 10 fathoms in the sea, assuming the sp gr. of sea-water to be 1.026 and that a cubic foot of fresh water weighs $62\frac{1}{2}$ lbs

11. The sp gr. of mercury is 13.596, at what depth in mercury will the pressure be equal to that at a depth of 500 metres in water?

12. At what depth in mercury (sp. gr. = 13.596) will the pressure be equal to a kilogramme weight per sq cm.?

13. The mercurial barometer stands at 750 mm. and a cubic cm. of mercury weighs 13.6 grammes, a square valve, the length of whose side is one decimetre, closes an exhausted receiver, find approximately in grammes' weight the force that must be applied to its centre to open it

14. If the pressure of the atmosphere be 15 lbs wt per sq inch, and the weight of a cubic foot of water be $62\frac{1}{2}$ lbs, find the pressure per sq inch at a depth of (1) 10 feet, (2) one mile, below the surface of the water.

15. A vessel whose bottom is horizontal contains mercury whose depth is 30 inches and water floats on the mercury to a depth of 24 inches, find the pressure at a point on the bottom of the vessel in lbs wt per sq inch, the sp gr. of mercury being 13.6

16. A vessel is partly filled with water and then oil is poured in till it forms a layer 6 inches deep, find the pressure per sq inch due to the weight of the liquids at a point 8.5 inches below the upper surface of the oil, assuming the sp gr of the oil to be .92 and the weight of a cubic inch of water to be 252 grains

17. A vessel contains water and mercury, the depth of the water being two feet. It being given that the sp gr of mercury is 13.568 and that the mass of a cubic foot of water is 1000 ozs, find, in lbs wt per sq inch, the pressure at a depth of two inches below the common surface of the water and mercury

18. The lower ends of two vertical tubes, whose cross sections are 1 and 1 sq inches respectively, are connected by a tube. The tube contains mercury of sp gr 13.596. How much water must be poured into the larger tube to raise the level in the smaller tube by one inch?

19. *A small uniform tube is bent into the form of a circle, whose plane is vertical, equal quantities of fluids, whose densities are ρ and σ , fill half of the tube, shew that the radius passing through the common surface makes with the vertical an angle*

$$\tan^{-1} \frac{\rho - \sigma}{\rho + \sigma}.$$

Let A, B be the highest and lowest points of the liquids, so that AB goes through the centre O , the point C where the liquids join is therefore such that $\angle AOC = \angle BOC = 90^\circ$.

Draw AL, BM, CN perpendicular to the vertical diameter of which D is the lowest point

By Art 28, considering the fluid BD , we have the pressure at $D = \rho w \cdot DM$.

Also, considering the fluid DCA , the pressure at D
 $= \rho v \ DN +$ pressure at $C = \rho v \ DN + \sigma w \ NL$.

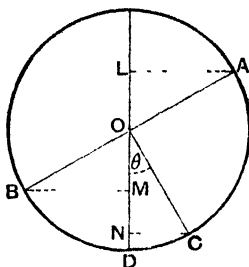

$$\therefore \rho \ DM = \rho \cdot DN + \sigma \ NL,$$

1 e.

$$\rho \ NM = \sigma \ NL,$$

1 e.

$$\rho [\cos \theta - \cos (90^\circ - \theta)] = \sigma [\cos \theta + \cos (90^\circ - \theta)],$$

1 e

$$\rho (\cos \theta - \sin \theta) = \sigma (\cos \theta + \sin \theta),$$

1 e

$$\tan \theta = \frac{\rho - \sigma}{\rho + \sigma}$$

20. A fine circular tube in a vertical plane contains a column of liquid, of density ρ , which subtends a right angle at the centre and a column, of density σ , subtending an angle α . Prove that the radius through the common surface makes with the vertical an angle

$$\tan^{-1} \frac{\rho - \sigma + \sigma \cos \alpha}{\rho + \sigma \sin \alpha}.$$

21. In the lower half of a uniform circular tube one quadrant is occupied by a liquid of density 2ρ and the other by two liquids, which do not mix, of densities 3ρ and ρ , prove that the volume of the lower of the two latter liquids is twice that of the other.

22. A circular tube of fine uniform bore is half filled with equal volumes of four liquids, which do not mix and whose densities are as 1 4 8 7, and is held with its plane vertical, shew that the diameter joining the free surfaces makes an angle $\tan^{-1} 2$ with the vertical.

23. n liquids are arranged in strata of equal thickness h , the density of the uppermost being ρ , that of the next 2ρ , and so on, that of the lowest being $n\rho$; find the pressure at the lowest point of the lowest stratum.

24. In a heterogeneous fluid where the density at depth z is $\frac{\rho z}{a}$, show that the pressure there is

$$H + \frac{g\rho z^2}{2a}.$$

39. Whole Pressure. Def. *If for every small element of area of a material surface immersed in fluid the pressure perpendicular to this small element be found, the sum of all such pressures is called the whole pressure of the fluid upon the given surface*

If this surface be a plane surface, the whole pressure is easily seen to be equal to the resultant force, or thrust, acting on it. By the following theorem it will be shewn how this thrust may be calculated.

Theorem. *If a plane surface be immersed in a liquid, the whole pressure or thrust on it is equal to $wS \bar{z}$, where S is the area of the plane surface and \bar{z} is the depth of its centre of gravity below the surface of the liquid, the pressure of the air being neglected*

For consider any plane area, horizontal or inclined to the horizon, which is immersed in the liquid.

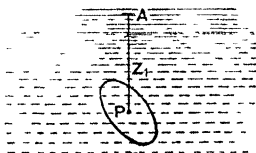

Consider any small element a_1 of the plane surface situated at P , and draw PA vertical to meet the surface of the liquid in A , and let PA be z_1

The pressure on this small area is therefore wa_1z_1
(Art. 28)

Similarly if a_2, a_3, \dots be any other elements of the plane surface whose depths are z_2, z_3, \dots the pressures on them are

$$wa_2z_2, wa_3z_3, \dots$$

Hence the resultant thrust

$$= w [a_1 z_1 + a_2 z_2 + \dots]. \quad [\textit{Statics, Art 55}]$$

But, if \bar{z} be the depth of the centre of gravity of the given plane area, we have, as in *Statics*, Art 111,

$$\bar{z} = \frac{a_1 z_1 + a_2 z_2 + \dots}{a_1 + a_2 + \dots}.$$

$$\therefore a_1 z_1 + a_2 z_2 + \dots = z (a_1 + a_2 + \dots) = \bar{z} \delta$$

Hence the resultant thrust = $w \bar{z} S$ = area of the surface multiplied by the pressure at its centre of gravity,

i.e. the resultant thrust is equal to the weight of a column of liquid whose base is equal to the area of the given plane surface, and whose height is equal to the depth below the surface of the liquid of the centre of gravity of the given plane surface

40. If the pressure of the air is not to be neglected, we must understand by \bar{z} the depth of the centre of gravity below the ‘effective surface,’ *i.e.* below a surface at a height h above the surface of the liquid, where h is the height of the barometer made of that liquid

If the pressure of the atmosphere is given as Π per unit of area, the part of the thrust on S due to the atmosphere is $\Pi \cdot S$

41. If the surface considered be not plane, but be any curved surface, the whole pressure is still given by the formula of Art 39, and the proof is exactly as in that article.

In the case of a curved surface, however, the whole pressure has no physical meaning whatever, and thus its calculation serves no useful purpose. The student must carefully notice that, in the case of a curved surface, the

whole pressure is not the resultant thrust on the curved surface. We shall see how to obtain this resultant thrust in the next chapter.

42 Ex 1 *A square plate, whose edge is 8 inches, is immersed in sea-water, its upper edge being horizontal and at a depth of 12 inches below the surface of the water. Find the thrust of the water on the surface of the plate when it is inclined at 45° to the horizon, the mass of a cubic foot of sea-water being 64 lbs.*

The depth of the centre of gravity of the plate

$$= 12 + 4 \cos 45^\circ = (12 + 2\sqrt{2}) \text{ inches} = \frac{6 + \sqrt{2}}{6} \text{ ft.}$$

Also the area of the plate = $\left(\frac{2}{3}\right)^2$ sq ft.

Hence the thrust

$$\begin{aligned} &= \frac{4}{9} \times \frac{6 + \sqrt{2}}{6} \times 64 \text{ lbs wt} \\ &= 35.149 \text{ lbs wt nearly} \end{aligned}$$

Ex 2 *A hollow cone stands with its base on a horizontal table. The area of the base is 100 sq inches and the height of the cone is 8.64 inches and it is filled with water. Find the thrust on the base of the cone and its ratio to the weight of the water in the cone.*

The thrust = wt of 100×8.64 cubic inches of water

$$\begin{aligned} &= \frac{864}{1728} \times 1000 \text{ ozs wt} = 500 \text{ ozs wt.} \\ &= 31.25 \text{ lbs wt} \end{aligned}$$

Since the volume of the cone is one-third the product of the height and the area of the base, the weight of the contained water

$$\begin{aligned} &= \text{wt of } \frac{1}{3} \times 100 \times 8.64 \text{ cubic inches} \\ &= \frac{1}{3} \times 31.25 \text{ lbs wt} \end{aligned}$$

Hence, the thrust on the base of the cone

$$= \text{three times the weight of the contained water}$$

This result, which at first sight seems impossible, is explained by the fact that the upward thrust of the base has to balance both the weight of the liquid and also the vertical component of the thrust of the curved surface of the cone upon the contained fluid, and this component acts downward and could be proved by the next Chapter to be equal to twice the weight of the contained fluid.

Ex. 3 A liquid, whose specific weight is w' , rests to a depth a upon another liquid, with which it does not mix, whose specific weight is w . A square of side b ($> a$) is immersed in the two liquids, its upper edge being in the surface of the upper fluid and its plane being vertical. Find the thrust on the square.

The thrust of the liquids on the square may be considered to be due to the thrust of two liquids, one, of specific weight w' , in contact with the whole square, and the other, of specific weight $w - w'$, in contact with the lower part only of the square

The required thrust will be the sum of the thrusts due to the two liquids

The thrust due to the first, by Art 39,

$$= w' \times b^2 \times \frac{b}{2}.$$

The thrust due to the second

$$= (w - w') \times b(b - a) \times \frac{b - a}{2}.$$

∴ the total thrust

$$\begin{aligned} &= w' \times \frac{b^3}{2} + (w - w') \times \frac{b}{2} (b - a)^2 \\ &= \frac{1}{2} w b (b - a)^2 + \frac{1}{2} w' b [b^2 - (b - a)^2] \\ &= \frac{1}{2} w b (b - a)^2 + \frac{1}{2} w' a b (2b - a) \end{aligned}$$

Alter. The thrust may also be calculated thus,

The thrust on the portion of the square in the upper fluid

$$= w' \times ba \times \frac{a}{2}$$

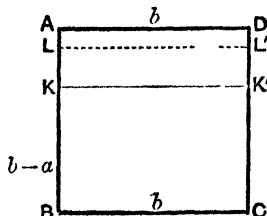

To find the thrust on the lower portion $KBCK'$ imagine the liquid $AKK'D$, of specific wt w' , to be replaced by a portion $LKK'L'$ of

specific wt w , which would cause the same pressure at the level KK' that the given liquid does, so that

$$KL \quad w = Ka \quad w' = a \cdot w'.$$

∴ thrust on $KBCK'$

$$= \text{its area} \times w \times \left(KL + \frac{b-a}{2} \right) \quad (\text{Art. 39})$$

$$= b(b-a) \times w \times \left[\frac{aw'}{w} + \frac{b-a}{2} \right]$$

$$= b(b-a) \times [aw' + \frac{1}{2}(b-a)w]$$

the required resultant thrust

$$= \frac{1}{2}w'ba^2 + b(b-a)[aw' + \frac{1}{2}(b-a)w]$$

$$= \frac{1}{2}b(b-a)^2w + abw' \left[\frac{a}{2} + b - a \right]$$

$$= \frac{1}{2}b(b-a)^2w + \frac{1}{2}ab(2b-a)w',$$

as before.

EXAMPLES. V.

1. A cube, each of whose edges is 2 ft long, stands on one of its faces on the bottom of a vessel containing water 4 ft deep. Find the thrust of the water on one of its upright faces.

2. Water is supplied from a reservoir which is 400 ft. above the level of the sea. A tap in one of the houses supplied is at a height of 150 ft above the sea-level and has an area of $1\frac{1}{2}$ sq ins. Find the thrust on the tap.

3. A cube of 30 cms edge is suspended in water with its upper face horizontal and at a depth of 75 cms. below the surface. Find the thrust on each face of the cube.

4. A hole, six ins sq, is made in a ship's bottom 20 ft. below the water-line. What force must be exerted to keep the water out by holding a piece of wood against the hole, assuming that a cubic ft of sea water weighs 64 lbs.?

5. Find the resultant thrust on either side of a vertical wall, whose breadth is 8 ft and depth 12 ft, which is built in water with its upper edge in the surface, the height of the water-barometer being 33 ft.

6. A vessel, whose base is 15 cms sq and whose height is 15 cms, has a neck of section 10 sq cms and of height 7.5 cms, if it be filled with water, find the thrust on the base of the vessel

7. If the height of the water-barometer be 1033 cms, what will be the thrust on a circular disc whose radius is 7 cms when it is sunk to a depth of 50 metres in water?

8. The dam of a reservoir is 200 yards long and its face towards the water is rectangular and inclined at 30° to the horizon. Find the thrust acting on the dam when the water is 30 ft deep.

Has the size of the surface of the water in the reservoir any effect on this thrust?

9. A vessel shaped like a portion of a cone is filled with water. It is one inch in diameter at the top and eight inches in diameter at the bottom and is 12 ins high. Find the pressure in lbs wt per sq in at the centre of the base and also the thrust on the base.

10. A square is placed in liquid with one side in the surface. Shew how to draw a horizontal line in the square dividing it into two portions, the thrusts on which are the same.

11. A vessel, in the shape of a cube whose side is one decimetre, is filled to one third of its height with mercury whose sp gr is 13.6 while the rest is filled with water. Find the thrust against one of its sides in kilogrammes wt.

12. A vessel, one foot high, is filled to a height of 8 inches with mercury and the remainder of the vessel is filled with water; if one side of the vessel be 10 inches long, find the thrust on one face of it, given that the sp gr of mercury is 13.596, and that the atmospheric pressure is 15 lbs wt per square inch.

13. A rectangular vessel, one face of which is of height two feet and width one foot, is half filled with mercury and half with water. Find the thrust on this face, given that the sp gr of mercury is 13.5.

14. Two equal small areas are marked on the side of a reservoir at different depths below the surface of the water. If the thrust on A be four times that of B and if water be drawn off so that the surface of the water in the reservoir falls one foot, the thrust on A is now nine times that on B . What were the original depths of A and B below the surface of the water?

15. A cubical box, whose edge measures 1 ft, has a pipe communicating with it which rises to a vertical height of 20 ft above the lid. It is filled with water to the top of the pipe. Find the upward thrust on the lid and the downward thrust on the base, and shew that their difference is equal to the weight of the water in the box.

How do you explain the fact that the thrust on the base is greater than the weight of the liquid it contains?

16. An artificial lake, $\frac{1}{4}$ mile long and 100 yards broad, with a gradually shelving bottom whose depth varies from nothing at one end to 88 ft. at the other, is dammed at the deep end by a masonry wall across its entire breadth. If the weight of the water be $\frac{3}{4}$ ton weight per cubic yard, prove that the thrust on the embankment is $32266\frac{2}{3}$ tons weight, and that the total weight of the water in the lake is 484000 tons.

17. The sides of a cistern are vertical. Its base is a horizontal regular hexagon each side of which is $\sqrt{3}$ feet long. Find its depth if when it is full of water the thrust on each of its sides is the same as on its base.

18. A regular tetrahedron, whose edges are each of length a , is completely immersed in water with one of its faces horizontal and the opposite angular point downwards. Given the depth d of this face, find the thrust on each face and deduce the resultant thrust on the tetrahedron.

19. The width of a rectangular vertical dock-gate is 50 ft., and on one side there is salt-water (sp. gr. 1.026) to a depth of 25 ft. On the other side there is fresh water, find its depth if the thrusts on the two sides are equal.

20. A hollow cone, whose axis is vertical and base downwards, is filled with equal volumes of two liquids whose densities are in the ratio of 3 : 1, shew that the thrust on the base is $(3 - \sqrt[3]{4})$ times as much as it is when the vessel is filled with the lighter fluid.

Find the thrust on

21. a rectangle, whose sides are a and b , the side a being horizontal and at a depth c below the surface and the plane of the rectangle being inclined at an angle θ to the vertical.

22. each of the plane ends of a circular cylinder, of height h and radius of base a , the middle point of the cylinder being at the depth c below the surface of the fluid, and its axis being inclined at an angle θ to the vertical.

23. A cone, full of water, is placed on its side on a horizontal table, shew that the thrust on its base is $3 \sin \alpha$ times the weight of the contained fluid, where 2α is the vertical angle of the cone.

24. A hollow weightless cone, of vertical angle 2α , is filled with fluid and suspended freely from a point on the rim of its base, shew that the thrust on the base is to the weight of water the cone would contain in the ratio of

$$12 \sin^3 \alpha \text{ to } \cos \alpha \sqrt{1 + 15 \sin^2 \alpha}.$$

25. A hollow weightless hemisphere, filled with liquid, is suspended freely from a point in the rim of its base; shew that the thrust on the plane base is to the weight of the contained liquid as $12 \sqrt{73}$

26. A parallelogram is immersed in water one side being in the surface; divide it into n parts by horizontal lines so that the thrusts on these parts may be equal. Shew that the depths of the dividing lines are proportional to the square roots of the natural numbers.

27. A square lamina $ABCD$ is immersed in water with the side AB in the surface. Draw a straight line through A which shall divide the lamina into two parts the thrusts on which are equal.

28. Divide a square immersed vertically in a fluid with one side in the surface by a straight line parallel to a diagonal so that the thrusts on the two parts may be equal.

29. A semi-circular area is immersed in liquid with the diameter in the surface and its plane vertical, shew how to divide it into n sectors the thrusts on each of which are the same.

30. A triangle is completely immersed in liquid with the vertex C in its surface, shew how to divide the triangle into two parts by a straight line drawn through A so that the thrusts on the two parts may be equal.

31. The lighter of two liquids, of density ρ , rests on the heavier, of density σ , to a depth of a inches. A square of side b is immersed in a vertical position with one side in the surface of the upper liquid; if the thrusts on the two portions of the square in contact with the two liquids be equal, prove that

$$\rho a(3a - 2b) = \sigma(b - a)^2$$

32. ABC is a triangle immersed vertically in water with C in the surface and the sides AC, BC equally inclined to the surface; prove that the vertical through C divides the triangle into two others the thrusts on which are in the ratio

$$b^3 + 3ab^2 : a^3 + 3a^2b.$$

33. A cubical box with vertical sides is filled with equal volumes of n different liquids, which do not mix, the density of the uppermost being ρ that of the next 2ρ , and that of the lowest $n\rho$. Shew that the thrust on the base is $(n+1)$ times the thrust on that part of one of the sides which is in contact with the lowest liquid.

34. A cylindrical tumbler, half filled with a liquid of density ρ , is filled up with a liquid of density ρ' which does not mix with the former one. Shew that the thrust on the base of the tumbler is to the whole pressure on its curved surface as

$$2r(\rho + \rho') \text{ to } h(\rho + 3\rho'),$$

where h is the height and r the radius of the base of the tumbler.

35. A closed hollow cone is just filled with water and is placed with its vertex upwards and its axis vertical, divide its curved surface by a horizontal plane into two parts on which the whole pressures are equal.

Perform the same division when the vertex is downward

36. A cylinder is filled with equal volumes of n different fluids which do not mix, the density of the highest is ρ , that of the next is 2ρ , and so on, that of the lowest being $n\rho$, shew that the whole pressure on the different portions of the curved surfaces of the cylinder are in the ratios $1^2 \ 2^2 \ \dots \ n^2$

43. Centre of pressure of a plane area.

If a plane area be immersed in liquid, the pressure at any point of it is perpendicular to the plane area and is proportional to the depth of the point

The pressures at all the points on one side of this area therefore constitute a system of *parallel* forces whose magnitudes are known

By *Statics*, Art 53, it follows that all these parallel forces can be compounded into one single force acting at some definite point of the plane area

This single force is called the resultant fluid pressure and is in the case of a plane area the same as the whole pressure, and the point of the area at which it acts is called the centre of pressure of the given area

The determination of the centre of pressure in any given case is a question of some difficulty.

We shall not discuss it until Chap IX, but shall here state the position of the centre of pressure in one or two simple cases

(1) A rectangle $ABCD$ is immersed with one side AB

in the surface. If L and M be the middle points of AB and CD , the centre of pressure is at P , where $LP = \frac{2}{3}LM$.

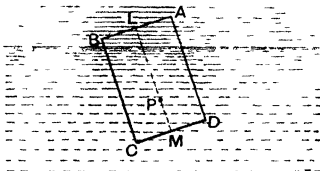

(2) A triangle ABC is immersed with an angular point A in the surface and the base BC horizontal. If D be the middle point of BC , the centre of pressure P lies on AD , such that $AP = \frac{1}{4}AD$.

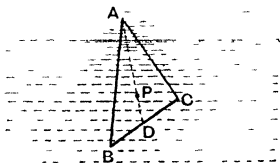

(3) A triangle ABC is immersed with its base BC in the surface. If D be the middle point of the base, the centre of pressure P bisects DA .

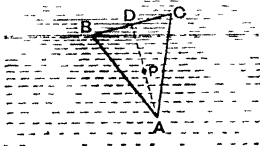

Ex A rectangular hole $ABCD$, whose lower side CD is horizontal, is made in the side of a reservoir, and is closed by a door whose plane is vertical, and the door can turn freely about a hinge coinciding with

AB. What force must be applied to the middle point of *CD* to keep the door shut if *AB* be one foot and *AD* 12 feet long, and if the water rise to the level of *AB*?

If *P* be the required force then its moment about *AB* and the moment of the pressure of the water about *AB* must be equal.

The thrust of the water, by Art. 39,

$$= 1 \times 12 \times 6 \times \frac{1000}{16} \text{ lbs wt} = 4500 \text{ lbs wt}$$

Also, by (1), it acts at a point whose distance from *AB*

$$= \frac{2}{3} AD = 8 \text{ feet}$$

Hence, by taking moments about *AB*,

$$P \times 12 = 4500 \times 8$$

$$\therefore P = 3000 \text{ lbs wt}$$

EXAMPLES VI.

1. A cubical box is filled with water, and is fitted with a lid *ABCD* consisting of a uniform square plate, whose weight is two-thirds that of the contained water. If the box is held so that the lid is inclined at an angle of 45° to the horizontal, and the hinge *AB* is horizontal and above *CD*, prove that the lid is on the point of opening.

2. The vertical side of a cubical box is movable about its upper edge to which is attached at right angles to the side a uniform rod weighing 5 lbs and of length equal to that of an edge, the weight of the water that would fill the box is 24 lbs, find how much water can be poured into the box before the side begins to move.

3. A horizontal tube containing water is closed by a square lid inclined at an angle of 45° with the horizontal and with two of its edges horizontal. If the lid be one ft square, and be movable about its lower edge as axis, find its weight if it be on the point of opening when the water stands level with its upper edge.

CHAPTER IV.

RESULTANT THRUST ON ANY SURFACE

44 If a portion of a curved surface be immersed in a heavy liquid, as in the figure of the next article, the determination of the total effect of the pressure of the liquid on it, *i.e.*, of the resultant liquid thrust, is a matter of some difficulty. For the pressures at different points of the surface act in different directions and in different planes.

By resolving the pressure on each element of the surface into vertical and horizontal components we can find forces to which the resultant thrust on the surface is equivalent.

We shall first find the total vertical force exerted by the liquid on the curved surface. This force is called the **Resultant Vertical Thrust**. It is equal to the resultant of the vertical components of the pressures which act at the different points of the given surface. For these vertical components compound, since they are parallel forces, into one single vertical force.

In the next article it will be shewn how this resultant vertical thrust may be found.

45. *Resultant vertical thrust on a surface immersed in heavy liquid*

Consider a portion of surface $PRQS$ immersed in the liquid. Through each point of the bounding edge of this

surface conceive a vertical line to be drawn, and let the points in which these vertical lines meet the surface of the liquid form the curve $ACBD$

Consider the equilibrium of the portion of the liquid enclosed by these vertical lines, by the surface $PRQS$, and

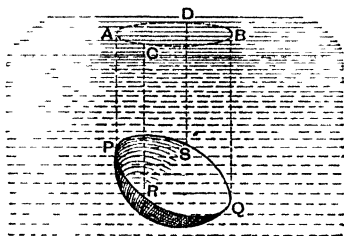

by the plane surface $ACBD$

Since, as in Art 28, the vertical thrust of *each* element of surface of $PSQR$ balances the weight of the corresponding thin superincumbent cylinder of fluid, therefore the resultant of all these elementary vertical thrusts (*ie* the resultant vertical thrust) must be equal and opposite to, and in the same line of action as, the resultant of the weights of these elementary columns. But this latter resultant is the weight of the liquid $PRQSDACB$ and acts at its centre of gravity

Also the thrust of the surface upon the liquid is equal and opposite to that of the liquid upon the surface

Hence, "*The resultant vertical thrust on any surface immersed in any heavy liquid is equal to the weight of the superincumbent liquid and acts through the centre of gravity of this superincumbent liquid.*"

46. If the liquid, instead of pressing the surface downwards, press it upward as in the adjoining figure, the same construction should be made as in the last article.

The pressure at any point of the surface $PRQS$ depends *only* on the depth of the point below the surface of the liquid.

Hence, in our case, the pressure is, at any point, equal in magnitude but opposite in direction to what the pressure

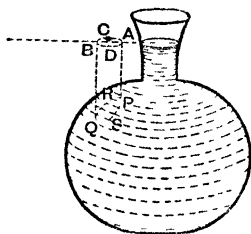

will be if the liquid inside the vessel be removed, and instead liquid be placed outside the vessel so that AB is its surface

In the latter case the resultant vertical thrust will be the weight of the liquid $PQAB$

Hence, in our case, *The resultant vertical thrust on the given portion of surface is equal to the weight of the liquid that could lie upon it up to the level of the surface of the liquid, and acts vertically upwards through the centre of gravity of this liquid.*

47. If the surface be as in the subjoined figure, the resultant vertical thrust on the part AB is upwards, and equal to the weight of the liquid that would occupy the space $BAED$.

The resultant vertical thrust on BC is downwards, and equal to the weight of the liquid that would occupy the

The resultant vertical thrust on the surface ABC is equal to the difference of these, and is thus equal to the weight of the liquid CBA and acts downwards

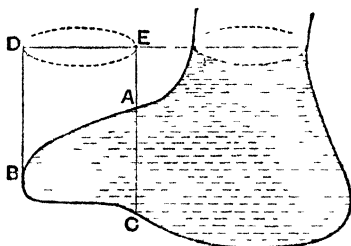

48. In Art 46, if the liquid be not homogeneous, the liquid that would occupy the space $PQAB$ must be supposed to have the same density at each point of it that the liquid in the vessel at the same depth below the surface as that point has. In this book, however, we shall meet with very few examples of liquid that is not homogeneous.

49. *The resultant vertical thrust on a body immersed, wholly or partly, in a liquid is equal to the weight of the liquid displaced.* [For another proof see Page 64.]

Consider the body $PTQU$ wholly immersed in a liquid

Let a vertical line be conceived to travel round the

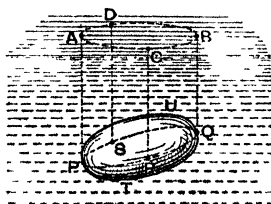

surface of the body, touching it in the curve $PRQS$ and meeting the surface of the liquid in the curve $ACBD$

The resultant vertical thrust on the surface $PTQRP$ is equal to the weight of the liquid that would occupy the space $PTQBA$ and acts vertically *upwards* through its $c.g.$

The resultant vertical thrust on the surface $PUQRP$ is equal to the weight of the liquid that would occupy the space $PUQBA$ and acts vertically *downwards* through its $c.g.$

The resultant vertical thrust on the whole body is equal to the resultant of these two thrusts, and is therefore equal to the weight of the liquid that would occupy the space $PTQU$ and acts *upwards* through the centre of gravity of the space $PTQU$

Hence, *The resultant vertical thrust on a body totally immersed is equal to the weight of the displaced liquid and acts vertically through the centre of gravity of the displaced liquid* [From Art 52 it will follow that the resultant horizontal thrust on the body is zero]

This centre of gravity of the displaced liquid is often called the **centre of buoyancy** of the body and the resultant vertical thrust is often called the **force of buoyancy**.

The important result just enunciated is known as the Principle of Archimedes, who was a Greek Philosopher and lived about 250 B C

50. The same theorem holds if the body be partially immersed, as may be easily seen

If the shape of the body be somewhat irregular, as in the figure on the next page, the resultant vertical thrust is equivalent to the weight of the liquid $APQB$ acting upwards, less the weights of the liquid $SDBQ$ and $BCAP$ acting

downwards, plus the weights of the liquid *DSM* and *CLR* acting upwards,

ze, is equivalent to the weight of the liquid that could be contained in *LRPQSM* acting upwards through its centre of gravity.

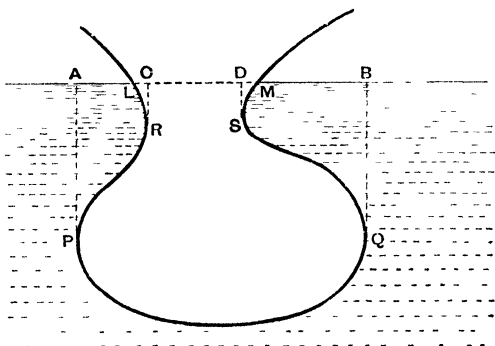

51. If the liquid is not homogeneous the remark of Art 48 applies, and the space occupied by the body must be supposed occupied by liquid of the same density as at the corresponding level outside the body

EXAMPLES. VII.

1. A vessel in the form of a portion of a cone is closed at the top and bottom by two circular plates, their diameters being 6 and 8 inches, and the vessel is filled with liquid. Compare the thrusts on the lower plate, according as the larger or the smaller plate is at the bottom

Explain why this thrust is in the one case greater, and in the other case less, than the weight of the liquid

2. A conical wine glass is filled with water and placed in an inverted position upon a table, shew that the thrust of the water upon the glass is two thirds of that upon the table.

3. A quantity of water which just fills a cone, whose height is h and the radius of whose base is r , is poured into a cylinder, the radius of whose base is also r . Compare the thrusts on the two bases, the axis of each vessel being vertical.

4. If a hollow cylinder be filled with water, and be closed at both ends and held with its axis horizontal, find the vertical thrust on the lower half of the curved surface.

5. A hemispherical bowl is filled with water and inverted and placed with its plane base in contact with a horizontal table, prove that the resultant vertical thrust on its surface is one third of the thrust on the table.

6. A right circular cone, closed by a base, is held with its axis horizontal and is full of water, find the resultant vertical thrust (1) on the upper half, (2) on the lower half, of the curved surface.

7. A bucket in the form of a frustum of a cone, the radii of its top and bottom being 6 and 4 inches respectively, is one foot high and is full of water, a cubic foot of which weighs 1000 ounces. Find the resultant vertical thrust on its curved surface.

8. A hollow closed vessel in the shape of a cylinder surmounted by a cone is filled with liquid. If the axis of the cone be three times as long as that of the cylinder, prove that the resultant thrust on the surface of the cone will be the same in the two positions in which the vessel can be placed with its axis vertical.

9. A double funnel, formed of two equal cones with a common axis communicating at their common vertex, is placed on a horizontal plane with the axis vertical and is filled with water, prove that the resultant vertical thrust on the curved surface of the lower cone is $2\frac{1}{2}$ times the weight of the water.

10. The shape of the interior of a vessel is a double cone, the ends being open and the two portions connected by a minute aperture at the common vertex, it is placed with one circular rim fitting close upon a horizontal plane and is filled with water, find the resultant vertical thrust on the vessel and shew that it will be zero if the length of the axis of the upper portion be twice that of the lower.

11. A heavy conical cup is placed vertex upwards on a smooth horizontal plane, and water is gradually poured in through a hole in the top. The weight of the cup is $\frac{1}{8}$ ths of the weight of the water which would just fill it; prove that the cup will be on the point of rising from the plane when the water has reached half the height of the cup.

12. A conical shell is placed with its vertex upwards on a horizontal table and liquid is poured in through a small hole in the vertex, if the cone begins to rise when the weight of the liquid poured in is equal to its own weight, prove that this weight is to the weight of the liquid that would fill the cone as $9 - 3\sqrt{3} : 4$.

13. A double funnel is formed by joining two equal hollow cones at their vertices, and stands on a horizontal plane with the common axis vertical; liquid is poured into the cone until its surface bisects the axis of the upper cone. If the liquid be now on the point of escaping between the lower cone and the table, prove that the weight of either cone is to that of the liquid it can hold as $27 : 16$.

52. To find the resultant horizontal thrust in a given direction on a given surface.

Through each point of the perimeter of the given surface draw horizontal lines PP', QQ', RR', SS' etc. in

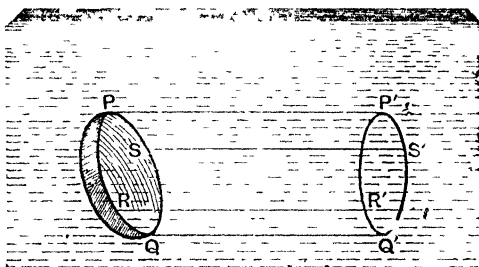

the given direction, and let these lines meet a vertical plane perpendicular to the given direction in a curve $P'R'Q'S'$

Take any very small element of area of $PQRS$ and construct, as in Art 27, a small thin cylinder on it whose other end is on the plane $P'Q'R'S'$, and whose generating

lines are parallel to PP' By resolving parallel to PP' the forces acting on it, we have

horizontal thrust on this small element of $PQRS$

= horizontal thrust on the corresponding small element of $P'Q'R'S'$

[For all the other forces acting on this thin cylinder, viz its weight and the pressures of the surrounding fluid, act in directions perpendicular to PP']

Since this is true for all such elements of area, if they are taken small enough, it follows that the resultant horizontal thrust on $PQRS$ in the direction PP' is equal and opposite to, and in the same line of action as, the resultant horizontal thrust on $P'Q'R'S'$ in the same direction

Now the latter is known in magnitude by Art 39 since it is the whole thrust on $P'Q'R'S'$, also its point of application is the centre of pressure of $P'Q'R'S'$

Hence *the resultant horizontal force in any given direction on any surface is equal to the whole thrust upon the projection of the surface upon a vertical plane perpendicular to that direction, and acts at the centre of pressure of that projection*

53 *Resultant thrust on any surface immersed in liquid*

We can now find the resultant thrust on any surface, the resultant vertical thrust is known in magnitude and line of action by Art 45

The resultant horizontal thrust in each of two horizontal directions at right angles is known by Art 52 in both magnitude and line of action

If these three forces compound into one single resultant

resultant is found by the proposition known as the Parallelopiped of Forces

54 Ex A hollow cylinder closed by a plane base is filled with liquid and held with its axis vertical, find the magnitude and the line of action of the resultant thrust on half the cylinder cut off by a vertical plane through the axis

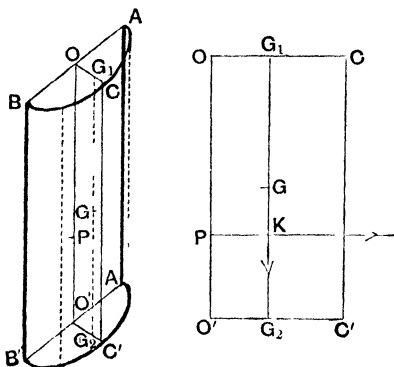

Let h be the height and r the radius of the base of the cylinder. Let $ABB'A'$ be the section of the cylinder made by the dividing plane

Through O , the middle point of AB draw OC the bisecting radius of the upper bounding semi circle, and on it take C_1 , such that

$$OG_1 = \frac{4r}{3\pi} \quad [\text{Statics, Art 118}]$$

Then G_1 is the centre of gravity of this semi-circle

If we draw G_1G_2 vertically downwards to meet the base in G_2 and bisect G_1G_2 in G , then G is the centre of gravity of the semi-cylindrical mass of liquid that we are considering

The vertical thrust, by Art 45, acts through G , and

= weight of the semi-cylinder of liquid

$$= \frac{1}{2}\pi r^2 h w,$$

where w is the weight of unit volume

The horizontal thrust on the curved surface, by Art 52,

= the thrust on the rectangle $ABB'A'$.

This, by Art. 43 (1), acts at the centre of pressure P , where $OP = \frac{2}{3} OO'$, and its magnitude

$$= w \times \text{area of } ABB'A' \times \text{depth of its c.g.}$$

$$= w \times 2rh \times \frac{h}{2} = wh^2r$$

If, as in the right-hand figure, the vertical through G meets the horizontal through P in K , the required resultant thrust then acts through K , and, if its magnitude be R at an angle θ to the horizon, we have

$$R \cos \theta = wh^2r,$$

and

$$R \sin \theta = \frac{1}{2} \pi r^2 hw$$

$$\therefore \tan \theta = \frac{\pi r}{2h},$$

and

$$R = whr \sqrt{h^2 + \frac{1}{4} \pi^2 r^2}$$

The magnitude and line of action of the resultant thrust are thus found

EXAMPLES VIII.

1. A solid hemisphere, of radius a , is placed with its centre at a depth h below the surface of water, and has its plane base in a vertical plane, what is the horizontal thrust on its curved surface? Find also the resultant thrust on it

2. A solid right circular cone is placed with its axis horizontal and at a depth h below the surface of water, find the horizontal thrust on half of the cone cut off by a vertical plane through the axis

3. A hollow right circular cone, with its axis vertical and vertex downwards, is filled with liquid, find the resultant horizontal thrust on half of the curved surface determined by any plane through the axis.

4. If a hollow right circular cylinder is filled with liquid and held with its axis horizontal, find the magnitude and the line of action of the resultant thrust on half the curved surface cut off by a vertical plane through the axis

5. A vessel in the shape of a right circular cylinder is placed with its axis vertical and is half filled with water, and half with a liquid of sp. gr 2 which does not mix with water. Find the direction of the resultant thrust on the part of the surface cut off by a plane through its axis

6. A horizontal trough is semi-circular in section and is filled with water whose weight is W , if the trough be imagined to be divided into halves along the middle, shew that the water will tend to push them asunder horizontally with a force $\frac{W}{\pi}$.

Shew also that the resultant thrust of the water on either half of the trough makes with the vertical an angle $\cot^{-1} \frac{\pi}{2}$.

7. A solid right circular cone is divided into two parts by a plane through its axis and one of these portions is just immersed, vertex downwards, in water. Find the resultant thrust on its curved surface, and shew that it is inclined at an angle $\tan^{-1} \left(\frac{\pi}{2} \tan \alpha \right)$ to the horizontal, where α is the semi-vertical angle of the cone.

8. A solid right circular cone, of height h and vertical angle 2α , is made of uniform material and floats in water with its axis vertical and vertex downwards and a length h' of axis is immersed. The cone is bisected by a vertical plane through the axis and the two parts are hinged together at the vertex. Shew that the two parts will remain in contact if $h' > h \sin^2 \alpha$.

[The vertical and horizontal components of the thrust on one part are known, as in Arts 45 and 52, and their points of application are known, if the sum of the moments of these two components about the vertex is greater than the moment of the weight of one part, the two parts will not separate.]

9. A thin hollow vessel in the shape of a right cone with a circular base is cut in two by a plane through the axis, and the two parts are hinged together at the vertex and the edges greased so as to be watertight. The vessel is then hung up by the hinge and filled with water through a small aperture near the hinge. Shew that the water will not flow out if the vertical angle of the cone exceed 120° .

55. When a surface is bounded by a plane curve, the resultant thrust on it may often be more simply found without using Art. 52. The method is best shown by examples, as in the next article.

56. *Ex 1.* A hemisphere is immersed in water with its centre at a depth h and its plane base inclined at an angle α to the horizon, find the direction and magnitude of the resultant thrust on the curved surface.

Let ACB be the plane base of the hemisphere whose centre is O , and whose centre of gravity is G . Let a be its radius

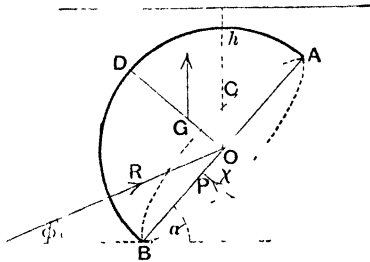

The resultant thrust on the whole body is, by Art 49, equal to the weight of the liquid displaced, viz $\frac{2}{3}\pi a^3 w$, and acts vertically through G

But this thrust is the resultant of

(1) the thrust X on the plane base ACB , which equals $\pi a^2 h w$ (Art 39), and acts perpendicular to the plane base at some point P which must by symmetry lie on AB , and

(2) the pressures of the liquid at the different points of the curved surface of the hemisphere, the direction of each such pressure acts normally to the surface of the sphere and thus goes through the centre O , the resultant thrust on the curved surface thus acts through O and must be equal to some force R acting at some angle ϕ to the horizon

Equating the resultant of R and X to the vertical thrust $\frac{2}{3}\pi a^3 w$, we have

$$\begin{cases} \frac{2}{3}\pi a^3 w = R \sin \phi + X \cos \alpha = R \sin \phi + \pi a^2 h w \cos \alpha, \\ O = R \cos \phi - X \sin \alpha = R \cos \phi - \pi a^2 h w \sin \alpha. \end{cases}$$

$$\therefore \left. \begin{aligned} R \sin \phi &= \pi a^2 w \left[\frac{2}{3}a - h \cos \alpha \right] \\ \text{and } R \cos \phi &= \pi a^2 w h \sin \alpha \end{aligned} \right\}$$

$$\begin{aligned} \therefore R &= \pi a^2 w \sqrt{\left(\frac{2}{3}a - h \cos \alpha\right)^2 + h^2 \sin^2 \alpha} \\ &= \pi a^2 w \sqrt{h^2 \frac{4ah}{3} \cos \alpha + \frac{4a^2}{9}} \end{aligned}$$

$$\text{and } \tan \phi = \frac{\frac{2}{3}a - h \cos \alpha}{h \sin \alpha} = \frac{2a - 3h \cos \alpha}{3h \sin \alpha}.$$

We thus have the direction and magnitude of the resultant thrust on the curved surface.

Cor If the plane base be as in the annexed figure then the thrust X acts downwards, and the equations given above become

$$\left. \begin{aligned} \frac{2}{3} \pi a^3 w &= R \sin \phi - X \cos \alpha, \\ 0 &= R \cos \phi - X \sin \alpha \end{aligned} \right\}$$

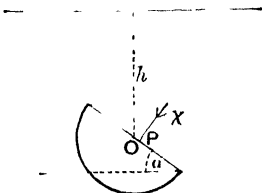

These then give

$$R = \pi a^2 w \sqrt{h^2 + \frac{4ah}{3} \cos \alpha + \frac{4a^2}{9}}$$

and $\tan \phi = \frac{2a + 3h \cos \alpha}{3h \sin \alpha}$

Ex 2 To find the centre of pressure of a plane circle immersed in liquid

In the previous example the moment of X about O must be equivalent to the moment of $\frac{2}{3} \pi a^3 w$ at G about O , since R goes through O

$$\therefore \lambda \quad OP = \frac{2}{3} \pi a w \times OG \sin \alpha,$$

i.e. $\pi a^2 h w \quad OP = \frac{2}{3} \pi a^3 w \times \frac{3a}{8} \sin \alpha$ [Statics, Art 225]

$$\therefore \quad OP = \frac{1}{4} \frac{a^2}{h} \sin \alpha$$

The distance of the centre of pressure of a circle from its centre is thus always equal to $\frac{a^2}{4h} \sin \alpha$

Cor If the circle had its plane vertical, so that $\alpha = 90^\circ$, then $OP = \frac{a^2}{4h}$, and thus, in this case, the depth of the centre of pressure below the surface of the liquid $= h + \frac{a^2}{4h}$, where a is the radius of the circle and h is the depth of the centre below the surface of the liquid

Ex 3 A cylinder closed at both ends is entirely immersed in water with its axis inclined at a given angle θ to the horizontal, if its height be h and the radius of its base be a , find the resultant horizontal and vertical thrusts on its curved surface.

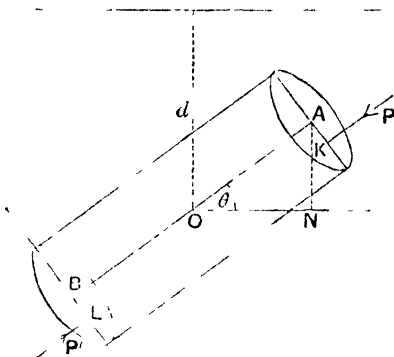

If d be the depth of the middle point O of the axis, the depth of the centre A of the uppermost plane end $= d - AN = d - \frac{h}{2} \sin \theta$, and thus the thrust P on this plane end

$$= \pi a^2 \left(d - \frac{h}{2} \sin \theta \right) w \quad (\text{Art 39}) \dots (1)$$

So the depth of the centre B of the lower plane end $= d + \frac{h}{2} \sin \theta$, and thus the pressure P' on this end

$$= \pi a^2 \left(d + \frac{h}{2} \sin \theta \right) w \quad \dots \dots (2)$$

Let H and V be the required horizontal and vertical thrusts on the curved portion of the cylinder, H being taken towards the left and V vertically upwards

Then the resultant of V , H and the thrusts, P and P' , on the two plane ends is equal to the resultant thrust on the whole cylinder, which is vertical and equal to $\pi a^2 h \times w$. (Art. 49.)

Hence, resolving horizontally and vertically, we have

$$\left. \begin{aligned} -H + (P' - P) \cos \theta &= 0, \\ V + (P' - P) \sin \theta &= \pi a^2 h w. \end{aligned} \right\}$$

and

Also, by (1) and (2), $P' - P = \pi a^2 h w \sin \theta$

$$H = (P' - P) \cos \theta = \pi a^2 h w \sin \theta \cos \theta,$$

and

$$V = \pi a^2 h w - \pi a^2 h w \sin^2 \theta = \pi a^2 h w \cos^2 \theta$$

The resultant thus $= \pi a^2 h w \cos \theta$ inclined at an angle $90^\circ - \theta$ to the horizontal, i.e. at θ to the vertical

By Ex 2, if K, L be the centres of pressure of the two faces, then

$$AK = \frac{a^2}{4 \left(d - \frac{h}{2} \sin \theta \right)} \cos \theta, \text{ and } BL = \frac{a^2}{4 \left(d + \frac{h}{2} \sin \theta \right)} \cos \theta$$

$$P AK = P' BL$$

the moments of the two parallel forces, P and P' , about O are equal and opposite.

Hence their resultant passes through O , also the direction of the resultant thrust on the whole cylinder passes through O .

the resultant of H and V passes through O

\therefore the resultant thrust on the curved surface passes through O , and is equal to $W \cos \theta$ at an angle θ with the vertical, where W is the weight of the water displaced by the cylinder.

EXAMPLES. IX.

1. A solid hemisphere is immersed in liquid with the highest point of its plane base in the surface, and the base is inclined at $\tan^{-1} 2$ to the horizon, shew that the resultant thrust on the curved surface is equal to twice the weight of the displaced liquid

2. A closed cylinder, whose height is equal to the diameter of its base, is filled with water, and hangs freely from a string fastened to a point on its upper rim, if the weight of the cylinder be neglected, shew that the vertical and horizontal components of the resultant thrust on its curved surface are each of them equal to half the weight of the contained water

3. A hollow weightless hemisphere with a plane base is filled with water and hung up by means of a string, one end of which is attached to a point of the rim of its base, find the inclination to the horizontal of the resultant thrust on its curved surface.

4. A right cone is filled with water, it is then closed and laid with a generating line in contact with a table; find the resultant vertical and horizontal thrusts upon the curved surface.

5. A solid cone is just immersed in water with a generating line in the surface, prove that the inclination to the vertical of the resultant thrust on the curved surface is $\tan^{-1} \frac{3 \tan \alpha}{1 - 2 \tan^2 \alpha}$, where 2α is the vertical angle of the cone

6. A cone floats with its axis horizontal in a liquid of density double its own, find the pressure on its base and prove that, if θ be the inclination to the vertical of the resultant thrust on the curved surface and α be the semi-vertical angle of the cone, then

$$\tan \theta = \frac{4}{\pi} \tan \alpha$$

7. A hollow cone, of vertical angle 2α , is filled with water and placed on its side on a plane, rough enough to prevent any sliding, which is inclined at an angle β to the horizon. Find the resultant horizontal and vertical thrusts on its curved surface, the vertex being the lowest point of the cone

8. A closed cylindrical vessel with hemispherical ends is filled with water, and placed with its axis horizontal. Find the resultant thrust on each of the ends, and determine its line of action

9. A weightless sphere is divided by a vertical plane into two halves which are hinged together at their lowest point, and it is just filled with water, shew that the tension of a string which ties together the highest points of the two halves is three eighths of the weight of the water that the whole sphere would contain

10. Two closely fitting hemispheres, made of sheet metal of small uniform thickness, are hinged together at a point on their rims, and are suspended from the hinge their rims being greased so that they form a watertight spherical shell. The shell is filled with water through a small hole near the hinge, prove that the contact will not give way if the weight of the shell exceeds three times the weight of the contained water.

Note The result of Art 49 (or 50) may also be shown thus, conceive the body removed, and the space $PUQRP$ to be filled up with extra liquid, the rest of the liquid being undisturbed. The pressure on each element of the surface of this extra liquid is the same as on the corresponding element of the solid (Art. 28), and hence the resultant thrust on the solid is the same as the resultant thrust on this extra liquid. But this latter balances the weight of the extra liquid. Hence etc.

CHAPTER V.

EQUILIBRIUM OF FLOATING BODIES.

57. *Conditions of equilibrium of a body freely floating in a liquid.*

Consider the equilibrium of a body floating wholly or partly immersed in a liquid

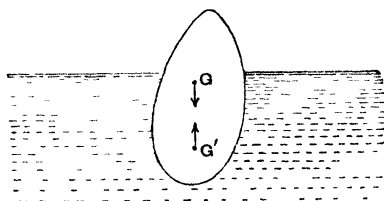

There are two, and only two, vertical forces acting on the body,

(1) its weight acting through the centre of gravity G of the body, and

(2) the resultant vertical thrust on the body which is equal to the weight of the displaced liquid and acts through the centre of buoyancy,

i. e. the centre of gravity G' of the displaced liquid

For equilibrium these two forces must be equal and act in opposite directions in the same vertical line

Hence the required conditions are

(1) The weight of the displaced liquid must be equal to the weight of the body, and

(2) The centres of gravity of the body and the displaced liquid must be in the same vertical line

58 Ex 1 A cylinder of wood, of height 6 feet and weight 50 lbs, floats in water. If its sp gr be $\frac{3}{4}$, find how much it will be depressed if a weight of 10 lbs be placed on its upper surface

Let A be the area of the section of the cylinder. Then

$$50 = A \cdot 6 \cdot \frac{3}{4} \quad u = 4 \cdot 6 \cdot \frac{1}{4} \cdot 62\frac{1}{2},$$

so that

$$A = \frac{50}{15} \text{ sq ft}$$

Let x be the distance through which the wood is depressed when 10 lbs are placed on it. The weight of the water which would occupy a cylinder, of section A and height x , must therefore be 10 lbs

$$10 = 1 \cdot x \cdot w = \frac{8}{45} \cdot x \cdot 62\frac{1}{2}$$

$$x = \frac{9}{10} \text{ ft}$$

Ex 2 A man, whose weight is equal to 160 lbs and whose sp gr is 1.1, can just float in water with his head above the surface by the aid of a piece of cork which is wholly immersed. Having given that the volume of his head is one-sixteenth of his whole volume and that the sp gr. of cork is .24, find the volume of the cork

Taking the wt. of a cubic ft. of water to be $62\frac{1}{2}$ lbs we have, if V be the volume of the man,

$$160 = V \times \frac{1}{10} \times 62\frac{1}{2},$$

so that

$$V = \frac{128}{5} \text{ cub ft}$$

Again, since the weight of the man and the cork must be equal to the weight of the liquid displaced, we have, if V' be the volume of the cork in cubic feet,

$$160 + V' \times 24 \times 62\frac{1}{2} = \left(\frac{1}{16}V + V'\right) \cdot 1 \cdot 62\frac{1}{2}$$

$$\therefore V' \times 76 \times 62\frac{1}{2} = 160 - \frac{1}{16}V \cdot 62\frac{1}{2} = 160 - \frac{1}{16} \cdot \frac{128}{5} \cdot 62\frac{1}{2} = 160 - \frac{128}{5} \cdot 62\frac{1}{2}$$

$$\frac{1}{2} V' = 160 - \frac{128}{5} \cdot 62\frac{1}{2} = \frac{260}{5}$$

$$\therefore V' = \frac{2}{5} \times \frac{260}{1} = \frac{520}{5} = 104 \text{ cub ft.}$$

Ex 3 A loaded piece of wood and an elastic bladder containing air just float at the surface of the sea, what will happen if they be both plunged to a great depth in the sea and then released?

The resultant upward thrust of a homogeneous liquid on a body is always the same, whatever be its depth below the surface of the liquid, provided that the volume of the body remains unaltered.

In the case of the wood, which we assume to be incompressible, the resultant thrust on it at a great depth is the same as at the surface and therefore the body just floats.

In the case of the elastic bladder the pressure of the sea at a great depth compresses the bladder, and it therefore displaces much less liquid than at the surface of the sea. The resultant vertical thrust therefore is much diminished, and, as the bladder only just floated at the surface, it will now sink.

EXAMPLES X.

1. A man, of weight 160 lbs., floats in water with 4 cubic inches of his body above the surface. What is his volume in cubic feet?

2. What weight of iron (sp gr = 7) must be attached to 1 lb of cork (sp gr = $\frac{1}{4}$) so that the combination may just float in water?

3. A certain body just floats in water. On placing it in sulphuric acid, of sp gr 1.85, it requires the addition of a weight of 42.5 grammes to immerse it. Find its volume.

4. A cubic foot of air weighs 1.2 ozs. A balloon so thin that the volume of its substance may be neglected contains 1.5 cubic ft of coal-gas, and the envelope together with the cap and appendages weighs 1 oz. The balloon just floats in the middle of a room without ascending or descending, find the sp gr of the gas compared with (1) air, and (2) water.

5. The mass of a litre (*i.e.*, a cubic decimetre) of air is 1.2 grammes and that of a litre of hydrogen is 0.089 grammes. The material of a balloon weighs 50 kilogrammes, what must be its volume so that it may just float when filled with hydrogen?

6. A piece of iron weighing 275 grammes floats in mercury of sp gr 15.59 with $\frac{5}{9}$ ths of its volume immersed. Find the volume and sp gr of the iron.

7. If an iceberg be in the form of a cube and float with a height of 30 ft above the surface of the water, what depth will it have below the surface of the water given that the densities of ice and sea-water are as 918 to 1025?

8. A ship, of mass 1000 tons, goes from fresh water to salt water. If the area of the section of the ship at the water line be 15000 sq ft and her sides vertical where they cut the water, find how much the ship will rise, taking the sp. gr. of sea-water to be 1.026

9. A ship sailing from the sea into a river sinks a inches, and on discharging x tons of her cargo rises b inches; if sea-water be one-fortieth heavier than river-water, prove that the mass of the ship is $41 \frac{a}{b} x$ tons

10. A cubical block of wood of sp. gr. 8, whose edge is one foot, floats with two faces horizontal down a fresh water river and out to sea where a fall of snow occurs causing the block to sink to the same depth as in the river. If the sp. gr. of sea-water be 1.025, shew that the weight of the snow on the block is 20 ozs

11. A piece of pomegranate wood, whose sp. gr. is 1.35, is fastened to a block of lignum vitæ, whose sp. gr. is .65, and the combination will then just float in water, shew that the volumes of the portions of wood are equal

12. A piece of cork, whose weight is 19 ozs, is attached to a bar of silver weighing 63 ozs and the two together just float in water; if the sp. gr. of silver be 10.5, find the sp. gr. of cork

13. A rod of uniform section is formed partly of platinum (sp. gr. = 21) and partly of iron (sp. gr. = 7.5). The platinum portion being 2 ins long, what will be the length of the iron portion when the whole floats in mercury (sp. gr. = 13.5) with one inch above the surface?

14. A piece of gold, of sp. gr. 19.25, weighs 96.25 grammes, and when immersed in water displaces 6 grammes. Examine whether the gold be hollow and, if it be, find the size of the cavity.

15. A man, whose weight is ten stone and whose sp. gr. is 1.1, just floats in water by holding under the water a quantity of cork. If the sp. gr. of the cork be .24, find its volume

16. A cylindrical lead pencil floats in water with $\frac{7}{8}$ ths of its volume immersed. If the lead is a cylinder whose radius is one-fourth that of the pencil and the sp. gr. of the wood is 78, find the sp. gr. of the lead

17. A block of wood floats in liquid with $\frac{4}{5}$ ths of its volume immersed. In another liquid it floats with $\frac{2}{3}$ rds of its volume immersed. If the liquids be mixed together in equal quantities by weight, what fraction of the volume of the wood would now be immersed?

X. EQUILIBRIUM OF FLOATING BODIES. 69

18. A solid displaces $\frac{1}{a}$, $\frac{1}{b}$, $\frac{1}{c}$ of its volume respectively when it floats in three different liquids, find what fraction of its volume it displaces when it floats in a mixture formed of (1) equal volumes, (2) equal weights of the liquids

19. A piece of iron, the mass of which is 26 lbs, is placed on the top of a cubical block of wood, floating in water, and sinks it so that the upper surface of the wood is level with the surface of the water. The iron is then removed. Find the mass of the iron that must be attached to the bottom of the wood so that the top may be as before in the surface of the water

$$[\text{Sp gr of iron} = 7.5]$$

20. A cubical box of one foot external dimensions is made of material of thickness one inch, and floats in water immersed to a depth of $3\frac{3}{4}$ inches. How many cubic ins of water must be poured in so that the water outside and inside may stand at the same level?

How deep in the water will the box then be?

21. A thin uniform rod, of weight W , is loaded at one end with a weight P of insignificant volume. If the rod float in an inclined position with $\frac{1}{n}$ th of its length out of the water, prove that

$$(n - 1)P = W$$

22. A thin cylindrical rod, weighted at one end, floats in water with half its length immersed and inclined at any angle to the horizon, prove that the weight which is added is equal to the weight of the rod

23. A thin uniform rod has a very small portion of heavy metal attached to one end, and it can float in water half immersed and inclined at any angle to the horizon, shew that the sp gr of the rod must be $\frac{1}{4}$.

24. A rod, of small section and of density ρ , has a small portion of metal of weight $\frac{1}{n}$ th that of the rod attached to one extremity, prove that the rod will float at any inclination in a liquid of density σ if

$$(n + 1)^2 \rho = n^2 \sigma$$

25. An ordinary bottle containing air and water floats in water neck downwards. Shew that if it be immersed in water to a sufficient depth and left to itself it will sink to the bottom. What condition determines the point at which it would neither rise nor sink?

26. A steamer, whose load is 30 tons to the inch in the neighbourhood of the water line in fresh water, is found after a 10 days' voyage (in which 60 tons of coal per day are burnt), to have risen 2 feet in sea water at the end of the voyage, prove that the original displacement of the steamer was 5720 tons, taking a cubic foot of fresh water as 62.5 and that of sea-water as 64 lbs

27. A solid cone has its axis of length h and is of density ρ , if it floats, with its vertex upwards, in a liquid of density σ ($> \rho$), how much of its axis is out of the fluid?

28. A cone, 7 inches in height and 2 inches in diameter at its base, is attached at its base to a hemisphere of equal diameter, the sp gr of the cone being $1\frac{1}{2}$ and that of the hemisphere $1\frac{3}{4}$, find the sp gr of a liquid in which the body would sink till only 3 inches of the axis of cone is out of the liquid

29. Shew that a homogeneous body in the shape of a right circular cone can float in a liquid of twice its own density with its axis horizontal

30. A hollow conical vessel floats in water with its vertex downwards and a certain depth of its axis immersed, when water is poured into it up to the level originally immersed, it sinks till its mouth is on a level with the surface of the water. What portion of the axis was originally immersed?

59. *A body floats with part of its volume immersed in one liquid and with the rest in another liquid, to determine the conditions of equilibrium*

The weight of the body must clearly be equal to the resultant vertical thrust of the two liquids, i.e. to the sum of the weights of the displaced portions of the two liquids, and must pass through the point on the line joining their centres of gravity at which the resultant of these two weights acts [Statics, Art 53]

This includes the case of a body floating partly immersed in liquid and partly in air

60. **Ex 1** *A vessel contains water and mercury. A cube of iron, 5 cms along each edge, is in equilibrium in the liquids with its faces vertical and horizontal. Find how much of it is in each liquid, the specific gravities of iron and mercury being 7.7 and 13.6*

Let x cms be the height of the part in the mercury and therefore $(5 - x)$ cms. that of the part in the water.

Since the weight of the iron is equal to the sum of the weights of the displaced mercury and water, therefore

$$5 \times 7.7 = x \times 13.6 + (5 - x) \times 1$$

$$\therefore x = 2 \frac{83}{128} \text{ cms}$$

Ex 2 A piece of wood floats in a beaker of water with $\frac{9}{10}$ ths of its volume immersed. When the beaker is put under the receiver of an air-pump and the air withdrawn, how is the immersion of the wood affected if the sp gr of air be 0.013?

Let V be the volume of the wood and xV the volume immersed when the air is withdrawn.

The wt of $\frac{9V}{10}$ of water together with that of $\frac{V}{10}$ of air must equal the wt of xV of water. For each is equal to the wt of the wood

$$\frac{9V}{10} \times 1 + \frac{V}{10} \times 0.013 = xV \times 1$$

$$x = 0.9013,$$

so that the volume immersed in water is increased from $9V$ to $90.13V$.

EXAMPLES XI.

1. A circular cylinder floats in water with its axis vertical, half its axis being immersed, find the sp gr of the cylinder if the sp gr of the air be 0.013.

2. An inch cube of a substance, of sp gr 1.2, is immersed in a vessel containing two liquids which do not mix. The sp grs of the liquids are 1.0 and 1.5. Find how much of the solid will be immersed in the lower liquid.

3. A uniform cylinder floats in mercury with 5.1432 ins of the axis immersed. Water is then poured on the mercury to a depth of one inch and it is found that 5.0697 ins of the axis is below the surface of the mercury. Find the sp gr of the mercury.

4. A mass composed partly of gold (sp gr 19.25) and partly of silver (sp gr 10.5) floats with $\frac{1}{6}$ ths of its volume immersed in mercury (sp gr 13.6) and the remainder in water. Compare the weights of the gold and silver in the mass.

5. A rectangular block of wood, 40 cms in depth and of sp gr 9, is floating in water with its upper surface horizontal. Oil of sp gr 6 is poured on to the water, so as to cover the wood, prove that the wood will rise through 6 cms.

6. If a body be floating partially immersed in a liquid and the air in contact with it be suddenly removed, will the body rise or sink?

7. Two liquids which do not mix are placed in the same vessel, the density of the lower liquid is ρ and that of the upper is $m\rho$, a cylinder floats in them with its axis vertical and is completely submerged, its density being $n\rho$, find the condition that it may be half in the upper and half in the lower liquid

8. A body floats in water contained in a vessel placed under an exhausted receiver with half its volume immersed. Air is then forced into the receiver until its density is 80 times that of air at atmospheric pressure. Prove that the volume immersed in water will then be $\frac{4}{9}$ ths of the whole volume, assuming the sp. gr. of air at atmospheric pressure to be 00125

9. A cube floats in distilled water with $\frac{4}{5}$ ths of its volume immersed. It is now placed inside a condenser where the pressure is that of ten atmospheres, find the alteration in the depth of immersion, the sp. gr. of the air at atmospheric pressure being 0013

10. A vertical cylinder, of density ρ , floats in two liquids, the density of the upper liquid being ρ_1 and that of the lower ρ_2 , if the length, h , of the cylinder be n times the depth of the upper liquid, prove that the depth of immersion of the upper face of the cylinder is

$$\frac{h}{n} - h \frac{\rho_2 - \rho}{\rho_2 - \rho_1},$$

provided that $\rho < \rho_2$ and $> \rho_2 - \frac{\rho_2 - \rho_1}{n}$.

11. A right circular cone, of density ρ , floats just immersed with its vertex downwards in a vessel containing two liquids, of densities σ_1 and σ_2 respectively, shew that the plane of separation of the two liquids cuts off from the axis of the cone a fraction, $\sqrt[3]{\frac{\rho - \sigma_2}{\sigma_1 - \sigma_2}}$ of its length

61. *A body rests totally immersed in a given liquid, being supported by a string, to find the tension of the string*

The vertical upward forces acting on the body are the tension of the string and the resultant vertical thrust of the liquid which, by Art 49, is equal to the weight of the displaced liquid. The vertical downward force is the weight of the body

Hence, for equilibrium, we have

Tension of the string + wt of displaced liquid = wt of the body, so that

Tension of the string = wt of the body - wt of the displaced liquid

62. The tension of the string in the previous article is the apparent weight of the body in the given liquid, so that the apparent weight of the body in the given liquid is less than its real weight by the weight of the liquid which it displaces

If a body of weight W and sp gr s be immersed in water the weight of the water displaced is $\frac{W}{s}$, so that $\frac{W}{s}$ is the apparent loss of weight. If it be immersed in a liquid of sp gr s' the apparent loss of weight is $W \frac{s'}{s}$.

This fact is of some importance when we are "weighing" a given body by means of a balance or otherwise. To obtain a perfectly accurate result the weighing should be performed *in vacuo*. Otherwise there will be a slight discrepancy arising from the fact that the quantities of air displaced by the body and by the "weights" that we use are different. Since however the weights of the displaced air are in general very small compared with that of the body this discrepancy is not very great.

If great accuracy be desired the densities of the body weighed and of the weights must be found, and the true weight determined from the apparent weight as in the following article

63. *A substance, whose density is ρ , is weighed by means of weights, the density of which is ρ' , if σ be the density of the air, find what is the true weight corresponding to any apparent weight.*

Let W be the true weight of the substance, W_0 the apparent weight as shown by the balance, ϵ the sum of the "weights" used

Then, the balance being assumed to be true, the tensions of the two supporting strings of the scale pans are equal, ϵ

wt of substance - wt of the air it displaces

= wt of the "weights" - wt of the air they displace,

$$\epsilon \quad W - \frac{W}{\rho} \sigma = W_0 - \frac{W_0}{\rho'} \sigma \quad \dots \dots \quad (1)$$

[For the volume of the substance is $\frac{W}{\rho g}$ (Art 18), and therefore the weight of the air it displaces is $\frac{W}{\rho} \sigma$

So the volume of the weights is $\frac{W_0}{\rho' g}$, and thus the weight of the air they displace is $\frac{W_0}{\rho'} \sigma$]

$$\dots \quad W = W_0 \frac{1 - \frac{\sigma}{\rho'}}{1 - \frac{\sigma}{\rho}} \quad \dots \dots \dots (2)$$

The true weight of any substance is thus found by multi-

plying the apparent weight by the fraction $\frac{1 - \frac{\sigma}{\rho'}}{1 - \frac{\sigma}{\rho}}$

Now, in general, the density of the air is very small compared with the densities of the substance and the "weights," that is, σ is very small compared with ρ and ρ' . Thus this fraction

$$\begin{aligned}
&= \left(1 - \frac{\sigma}{\rho'}\right) \left(1 - \frac{\sigma}{\rho}\right)^{-1} \\
&= \left(1 - \frac{\sigma}{\rho'}\right) \left(1 + \frac{\sigma}{\rho} + \text{higher powers of } \frac{\sigma}{\rho}\right),
\end{aligned}$$

by the Binomial Theorem,

$$= 1 - \frac{\sigma}{\rho'} + \frac{\sigma}{\rho},$$

squares and higher powers of σ being neglected

Thus a sufficiently near approximation is in general

$$W = W_0 \left[1 - \frac{\sigma}{\rho'} + \frac{\sigma}{\rho}\right]$$

64 Ex An accurate balance is completely immersed in a vessel of water. In one scale pan some glass (sp gr = 2.5) is being weighed and is balanced by a one-pound weight, whose sp gr is 8, which is placed in the other scale-pan. Find the real weight of the glass.

Let the real weight of the glass be W lbs. The weight of the water which the glass displaces therefore = $\frac{1}{2.5} W = \frac{2}{5} W$

The tension of the string holding the scale-pan in which is the glass therefore

$$= W - \frac{2}{5} W = \frac{3}{5} W$$

Again, the weight of the water displaced by the lb wt = $\frac{1}{8}$ lb wt, so that the tension of the string supporting the scale pan in which is the "weight"

$$= 1 \text{ lb wt} - \frac{1}{8} \text{ lb wt} = \frac{7}{8} \text{ lb wt}$$

Since the beam of the balance is horizontal, the tensions of these two strings must be the same

$$\frac{3}{5} W = \frac{7}{8},$$

so that

$$W = \frac{35}{24} = 1 \frac{11}{24} \text{ lbs wt.}$$

This is the real weight of the glass

EXAMPLES XII.

1. A body, whose wt is 18 lbs and whose sp gr is 3, is suspended by a string. What is the tension of the string when the body is suspended (1) in water, (2) in a liquid whose sp gr. is 2?

2. Water floats upon mercury whose sp gr is 13, and a mass of platinum whose sp gr. is 21 is held suspended by a string so that $\frac{19}{24}$ ths of its volume is immersed in the mercury and the remainder of its volume in the water. Prove that the tension of the string is half the weight of the platinum.

3. A piece of silver and a piece of gold are suspended from the two ends of a balance beam which is in equilibrium when the silver is immersed in alcohol (sp gr = 85) and the gold in nitric acid (sp gr = 1.5). The sp grs of silver and gold being 10.5 and 19.3 respectively, find the ratio of their masses.

4. If the sp gr of iron be 7.6, what will be the apparent weight of 1 cwt of iron when weighed in water, and how many lbs of wood of sp gr 6 will be required to be attached to it so that the joint body may just float?

5. A solid, of weight 1 oz., rests on the bottom of a vessel of water, if the thrust of the body on the bottom be $\frac{3}{7}$ oz., find its sp gr.

6. A body, whose volume is 30 cub cms. and sp gr 1.5, is placed in a vessel and just covered with water. What is its thrust upon the bottom of the vessel?

7. A mixture of gold (sp gr 19.25) and silver (sp gr 10.5) lost one-fourteenth of its weight when weighed in water, find the ratio of the volumes of the two metals.

8. A piece of lead and a piece of wood balance one another when weighed in air, which will really weigh the most and why?

9. The mass of a body A is twice that of a body B , but their apparent weights in water are the same. Given that the sp gr. of A is $\frac{5}{8}$, find that of B .

10. A vessel containing water is hung vertically from the end of a spring balance, and a body suspended from the end of a second spring balance is immersed in the water. How are the readings of the two balances altered?

11. A cylindrical vessel stands on a table and contains water, a piece of metal of given volume is dipped into the water, being supported by a string. How is the pressure on the base affected

(1) when the vessel is full, and

(2) when the vessel is not full?

In the second case, what is the change?

12. A block of wood, of volume 26 cub ins, floats in water with two-thirds of its volume immersed, find the volume of a piece of metal, whose sp gr is 8 times that of the wood, which, when suspended from the lower part of the wood, would cause it to be just totally immersed. When this is the case find the upward force which would hold the combined body just half immersed.

13. A cylindrical bucket, 10 ins in diameter and one foot high, is half filled with water. A half hundred weight of iron is suspended by a thin wire and held so that it is completely immersed in the water without touching the bottom of the bucket. Subsequently the wire is removed and the iron is allowed to rest on the bottom of the bucket. By how much will the thrust on the bottom be increased in each case by the presence of the iron?

[The mass of a cubic foot of iron is 410 lbs.]

14. If W , W' be the weights of a body in vacuo and water respectively, prove that its weight in air of sp gr s will be

$$W - s(W - W')$$

15. If the sp gr of air be s and W , W' be the weights of a body in air and water respectively, prove that its weight in vacuo is

$$W + \frac{s}{1-s}(W - W')$$

16. If w_1 , w_2 , w_3 be the apparent weights of a given body in fluids whose specific gravities are s_1 , s_2 , s_3 , then

$$w_1(s_2 - s_3) + w_2(s_3 - s_1) + w_3(s_1 - s_2) = 0.$$

17. Two solids are each weighed in succession in three homogeneous liquids of different densities, if the weights of the one are w_1 , w_2 , and w_3 and those of the others are W_1 , W_2 , and W_3 , prove that

$$w_1(W_2 - W_3) + w_2(W_3 - W_1) + w_3(W_1 - W_2) = 0$$

65. If a body be totally immersed in a liquid whose specific gravity is greater than that of the body, the resultant vertical thrust on the body is greater than its weight, and the body will ascend unless prevented from doing so.

Ex 1 A piece of wood, of weight 12 lbs and sp gr $\frac{3}{4}$, is tied by a string to the bottom of a vessel of water so as to be totally immersed. What is the tension of the string?

Since

$$\frac{\text{wt of water displaced by the wood}}{\text{wt of the wood}} = \frac{\text{sp gr of water}}{\text{sp gr of the wood}}$$

$$= \frac{1}{\frac{3}{4}} = \frac{4}{3}$$

$$\text{wt of the displaced water} = \frac{4}{3} \times 12 \text{ lbs wt} = 16 \text{ lbs wt}$$

For equilibrium we must have

$$\begin{aligned} \text{Tension of the string + wt of the wood} \\ &= \text{wt. of the displaced water} \\ \text{tension of the string} &= 16 - 12 = 4 \text{ lbs wt} \end{aligned}$$

Ex 2 *The mass of a balloon and the gas which it contains is 3500 lbs. If the balloon displace 48000 cub ft of air and the mass of a cub ft of air be 1.25 ozs, find the acceleration with which the balloon commences to ascend*

$$\begin{aligned} \text{The weight of the air displaced by the balloon} &= 48000 \times 1.25 \text{ oz wt} \\ &= 3750 \text{ lbs wt} \end{aligned}$$

$$\begin{aligned} \text{Hence the upward force on the balloon} \\ &= \text{wt of displaced air} - \text{wt of balloon} \\ &= 250 \text{ lbs wt} = 250g \text{ poundals} \end{aligned}$$

$$\text{initial acceleration of balloon} = \frac{\text{moving force}}{\text{mass moved}} = \frac{250g}{3500} = \frac{g}{14}$$

EXAMPLES XIII.

1. A piece of cork, weighing 30 grammes, is attached by a string to the bottom of a vessel filled with water so that the cork is wholly immersed. If the sp gr of the cork be .25, find the tension of the string.

2. A block of wood, whose sp gr is .8 and weight 6 lbs, is attached by a string, which cannot bear a strain of more than 2 lbs wt, to the bottom of a barrel partly filled with water in which the block is wholly immersed. Fluid whose sp gr is 1.2 is now poured into the barrel, so as to mix with the water, until the barrel is full. Prove that the string will break if the barrel were less than two-thirds full of water.

3. A cylinder of wood, whose weight is 15 lbs and length 3 ft, floats in water with its axis vertical and half immersed in water. What force will be required to depress it six inches more?

4. A litre of air contains 1.29 grms and a litre of coal gas 52 grms. A balloon contains 4,000,000 litres of coal-gas and the mass of the envelope and its appendages is 1,500,000 grms. What additional weight will it be able to sustain in the air?

5. A balloon containing 10 cub ft of hydrogen is prevented from rising by a string attached to it. Find the tension of the string, a cub ft of air being assumed to weigh 1.25 ozs and the sp gr of air being 14.6 times that of hydrogen.

6. The volume of a balloon and its appendages is 61,000 cub ft and its mass together with that of the gas it contains is 2 tons, with what acceleration will it commence to ascend if the mass of a cub ft of air be 1.24 ozs?

7. A triangular lamina ABC , of which the sides AB , AC are equal, floats in water with BC vertical, and three quarters of its length immersed, being kept in equilibrium in this position by means of a string fastened to A and the bottom of the vessel. Find the sp gr of the lamina, and shew that the tension of the string is $\frac{1}{27}$ th of the weight of the lamina.

66 *Conditions of equilibrium of a body partly immersed in a liquid and supported by a string attached to some point of it*

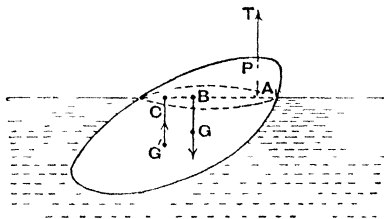

Let P be the point of the body at which the string is attached, and let T poundals be its tension.

Let V be the volume of the body, w its wt per unit of volume, and G its centre of gravity.

Let V' be the volume of the displaced liquid, w' its wt. per unit of volume, and G' its centre of gravity.

Let the vertical lines through P , G , and G' meet the surface of the liquid in the points A , B , and C .

The vertical forces acting on the body are

- (1) the tension T acting upwards through A ,
 - (2) the weight Vw acting downwards through B ,
- and (3) the resultant vertical pressure $V'w'$ acting upwards through C (Art 49)

Since these three forces are in equilibrium the points A , B , and C must be in the same straight line, and also, by *Statics*, Art 53, we must have

$$T + V'w' = Vw \quad . \quad . \quad . \quad (1),$$

and
$$V'w' \times AC = Vw \times AB \quad . \quad . \quad (11)$$

Ex A uniform rod, of length $2a$, floats partly immersed in a liquid, being supported by a string fastened to one of its ends. If the density of the liquid be $\frac{2}{3}$ times that of the rod, prove that the rod will rest with half its length out of the liquid.

Find also the tension of the string

Let LM be the rod, N the point where it meets the liquid, G' the middle point of MN , and G the middle point of the rod

Let w be the weight of a unit volume of the rod and $\frac{2}{3}w$ that of the liquid.

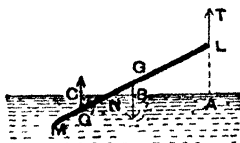

Let the length of the immersed portion of the rod be x , and k the sectional area of the rod

The weight of the rod is $k \cdot 2a \cdot w$ and that of the displaced liquid is $k \cdot x \cdot \frac{2}{3}w$.

If T be the tension of the string, the conditions of equilibrium are

$$T + k x \frac{4}{3} w = 2a k w \quad . \quad (1),$$

and $k x \frac{4}{3} w \times AC = 2a k w \times AB \quad . \quad . \quad . \quad (2)$

The second equation gives

$$\frac{2x}{3a} = \frac{AB}{AC} = \frac{LG}{LG'} = \frac{a}{2a - \frac{1}{2}x}.$$

$$x^2 - 4ax + 3a^2 = 0$$

Hence $x = a$, the larger solution $3a$ of this equation being clearly inadmissible

Hence half the rod is immersed

Also, substituting this value in (1), we have

$$T = \frac{2}{3} k . a \quad w = \frac{1}{3} \text{ wt of the rod.}$$

EXAMPLES XIV.

1. A uniform rod, six feet long, can move about a fulcrum which is above the surface of some water. In the position of equilibrium four feet of the rod are immersed, prove that its sp gr is $\frac{8}{9}$.

2. A uniform rod is suspended by two vertical strings attached to its extremities and half of it is immersed in water, if its sp gr be $2\frac{5}{7}$, prove that the tensions of the strings will be as 7

3. A uniform rod capable of turning about one of its ends, which is out of the water, rests inclined to the vertical with one-third of its length in some water, prove that its sp gr is $\frac{6}{9}$

4. A uniform rod, of length $2a$, can turn freely about one end which is fixed at a height h ($< 2a$) above the surface of a liquid, if the densities of the rod and liquid be ρ and σ , shew that the rod can rest either in a vertical position or inclined at an angle θ to the vertical such that

$$\cos \theta = \frac{h}{2a} \sqrt{\frac{\sigma}{\sigma - \rho}}.$$

Stability of equilibrium.

67. When a body is floating in liquid we have shewn that its centre of gravity G and the centre of buoyancy H must be in the same vertical line [Art. 57.]

Now let the body be slightly turned round, so that the line HG becomes inclined to the vertical. The thrust of the liquid in the new position may tend to bring the body back into its original position, in which case the equilibrium was *stable*, or it may tend to send the body still further from its original position, in which case the equilibrium was *unstable*.

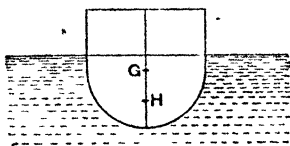

FIG 1.

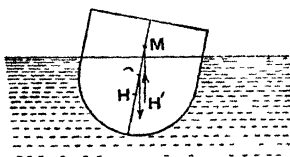

FIG 2

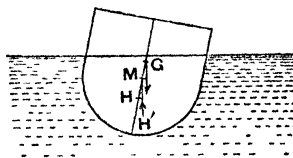

FIG 3.

The different cases are shewn in the annexed figures. Fig. 1 shews the body in its original position of equilibrium; in Figs. 2 and 3 it is shewn twisted through a small angle. In each case H' is the new centre of buoyancy and $H'M$ is drawn vertically to meet $H'G$ in M .

In Fig 2, where the point M is *above* G , the tendency of the forces is to turn the body in a direction opposite to

that in which the hands of a watch rotate. The body will therefore return toward its original position and the equilibrium was stable

In Fig 3, where the point M is below G , the tendency of the forces is opposite to that of Fig. 2. The body will therefore go further away from its original position and the equilibrium was unstable.

[We have assumed that, in the above figures, the vertical line through H' meets HG , this is generally the case for symmetrical bodies]

It follows that the stability of the equilibrium of the above body depends on the position of M with respect to G . On account of its importance the point M has a name and is called the Metacentre. It may be formally defined as follows

68. Metacentre Def. *If a body float freely, and be slightly displaced so that it displaces the same quantity of liquid as before, the point (if there be one) in which the vertical line through the new centre of buoyancy meets the line joining the centre of gravity of the body to the original centre of buoyancy is called the Metacentre*

The body is in stable or unstable equilibrium according as the Metacentre is above or below the centre of gravity of the body.

It follows therefore that, to insure the stability of a floating body, its centre of gravity must be kept as low as possible. Hence we see why a ship often carries ballast, and why it is necessary to load a hydrometer (Art. 80) at its lower end.

In any given case the determination of the position of the Metacentre is a matter of considerable difficulty. This position depends chiefly on the shape of the vessel

69. If the portion of the solid which is in contact with the liquid is spherical, it is clear that the centre of this spherical portion is the Metacentre. For the pressure at each point of the spherical surface is perpendicular to the surface and so passes through the centre, hence the total thrust passes always through the centre, and therefore the centre is the Metacentre

In this particular case the equilibrium of the body for small displacements will be stable or unstable, according as its centre of gravity is below or above the centre of the spherical portion [Cf *Statics*, Art 129.]

EXAMPLES XV.

1. A wooden ball is floating in water, shew that its equilibrium will become unstable if any weight, however small, be placed upon it at its highest point

2. A solid body consists of a right cone joined to a hemisphere on the same base and floats with the spherical portion partly immersed, prove that the greatest height of the cone consistent with stability is $\sqrt{3}$ times the radius of the base

3. A hollow buoy is made of a hemisphere and a cone joined at their bases, the thickness of the metal being the same throughout. Shew that it can float in stable equilibrium with the cone uppermost if the semi-vertical angle of the cone be 45° but not if it be 30° .

4. A body consists of a cylinder joined to a hemisphere on the same base, and floats with the spherical portion partly immersed in water, find the greatest height of the cylinder consistent with stability,

(1) if the body be solid and homogeneous,

(2) if it be hollow and made of metal which is of the same small thickness throughout

****10** Some harder examples on the subject of this chapter are appended,

Ex. 1 A cylindrical bucket with water in it balances a mass M by means of a string passing over a pulley. A piece of cork, of mass m and sp gr σ , is then tied to the middle point of the bottom of the bucket so as to be totally immersed. Prove that the tension of the string attached to the cork is

$$\frac{2Mmg}{2M+m} \left(\frac{1}{\sigma} - 1 \right).$$

Let f be the acceleration with which the bucket descends, so that

$$f = \frac{mg}{2M+m} \quad \text{.} \quad (1)$$

(Dynamics, Art 74)

During the motion let T be the tension of the string, and P the resultant vertical thrust of the liquid on the cork

$$mf = mg + T - P \quad \text{.} \quad (2)$$

Now if the cork were removed and replaced by an equal volume, $\frac{m}{\sigma}$, of water, this thrust P together with the weight of $\frac{m}{\sigma}$ would give it the acceleration f

$$\frac{m}{\sigma}f = \frac{m}{\sigma}g - P \quad \text{.} \quad (3)$$

By subtracting (3) from (2), we have

$$mf \left(1 - \frac{1}{\sigma}\right) = T + mg \left(1 - \frac{1}{\sigma}\right)$$

$$\therefore T = m(g - f) \left(\frac{1}{\sigma} - 1\right) = \frac{2Mmg}{2M+m} \left(\frac{1}{\sigma} - 1\right).$$

Ex 2 In the previous example, shew that the pressure at the lowest point of the curved surface of the bucket will be $\begin{matrix} > \\ < \end{matrix}$ than it was originally, according as the volume of the cork has to the volume of the water a ratio $\begin{matrix} > \\ < \end{matrix} \frac{m}{2M} 1$

Let h be the depth of the water originally, and H afterwards, and let a be the radius of the bucket, let v and V be the volumes of the cork and water respectively, so that $V = \pi a^2 h$

Then $\pi a^2 H = v + V,$

and $H = h + \frac{v+V}{\pi a^2} = h + \frac{v+V}{V} h.$

The pressure at the lowest point of the curved surface originally = $w h,$ and the pressure when there is motion

$$= w H \left(1 - \frac{f}{g}\right) \quad \text{[Dynamics, Art. 80.]}$$

$$= w h \frac{v+V}{V} \left[1 - \frac{m}{2M+m}\right]$$

$$= w h \cdot \frac{v+V}{V} - \frac{2M}{2M+m} w h.$$

HYDROSTATICS

This is greater than before if

$$2M(v + V) > (2M + m)V,$$

i.e. if

$$2Mv > mV,$$

i.e. if

$$\frac{v}{V} > \frac{m}{2M}.$$

Ex 3 A rectangle, movable about an angular point which is fixed below the surface of a liquid, floats with its sides equally inclined to the vertical and with half its area immersed in the liquid. If the lengths of its sides be a and b , and one of the sides of length b be entirely immersed in the liquid, shew that the ratio of the density of the body to that of the liquid is $a - b$ $4a$

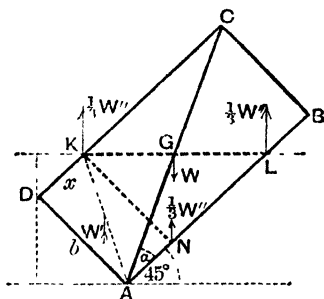

Since half of the rectangle is in the liquid, the surface KL of the liquid passes through G the middle point of the rectangle. Let $x = DK$, and draw KN perpendicular to AB . Since NK, NL are equally inclined to the horizon,

$$NL = NK = b$$

$$\therefore \frac{1}{2}ab = \text{rect } AK + \triangle KNL = x \cdot b + \frac{1}{2}b^2.$$

$$\therefore x = \frac{a-b}{2}, \text{ and } AL = \frac{a+b}{2}.$$

Let ρ and σ be the densities of the rectangle and the liquid

The weight W of the rectangle $= ab\rho$, and acts vertically through G .

The resultant vertical thrust of the liquid is equivalent to the wt of the amount $ANKD$ acting vertically through the middle point of AK , and the weight of the amount NKL acting at its centre of gravity.

$$\text{The weight } W' \text{ of } ANKD \text{ of liquid} = bx \cdot \sigma = \frac{1}{2}b(a-b)\sigma.$$

$$\text{The weight } W'' \text{ of } KNL \text{ of liquid} = \frac{1}{2}KN \cdot NL \cdot \sigma = \frac{1}{2}b^2\sigma$$

Also, as in *Statics*, Art 104, W'' acting at the centre of gravity of KNL is equivalent to $\frac{1}{3}W''$ at each of the angular points K , N , and L .

Taking moments about A , we therefore have

$$W \times \frac{1}{2} AC \cos(\alpha + 45^\circ) \\ = \frac{W''}{3} [x \cos 45^\circ + AL \cos 45^\circ - (b-x) \cos 45^\circ] - W' \times \frac{1}{2} (b-x) \cos 45^\circ,$$

where

$$\alpha = \angle BAC$$

$$\therefore \frac{W}{2} AC (\cos \alpha - \sin \alpha) = \frac{W''}{3} \left[x + \frac{a+b}{2} - b + \tau \right] - \frac{1}{2} W' (b-x)$$

$$\therefore W(a-b) = \frac{W''}{3} [4x + a - b] - W'(b - \tau),$$

$$\therefore ab\rho(a-b) = \frac{b^2\sigma}{6} \times 3(a-b) - \frac{1}{2} b(a-b)\sigma \times \frac{3b-a}{2}.$$

$$\therefore a\rho = \frac{b\sigma}{2} - \sigma \frac{3b-a}{4}.$$

$$\therefore \rho = \frac{a-b}{4a} \sigma.$$

NB The artifice of replacing the weight of a triangle by three equal forces acting at its angular points is often found useful in Hydrostatics

**MISCELLANEOUS EXAMPLES. XVI.

1. A uniform hemisphere, of weight W , floats in a liquid and a weight w is placed on the rim, prove that the base will be displaced through an angle $\tan^{-1} \frac{8w}{3W}$, the rim not being submerged.

2. A thin hollow cone, with a base, floats completely immersed in water wherever it is placed; shew that the vertical angle is $2 \sin^{-1} \frac{1}{3}$.

3. Two wooden parallelepipeds, each of sp. gr $\frac{1}{2}$, and weighing 100 and 50 lbs respectively, are floating in water, and a bar rests on them supported by iron pins fixed to the middle points of the upper surfaces of the pieces of wood, if the bar weighs 100 lbs and its centre of gravity be one-fourth of its length from the pin on the heavier piece of wood, find how much of each piece of wood will remain above the water

4. A prism, of weight W and sp. gr $\frac{1}{2}$, whose transverse section is an isosceles right-angled triangle, rests with the rectangular edge immersed in water, one of the remaining edges in the surface of the water, and both the upper edges in contact with smooth vertical planes, prove that the angle between the uppermost surface of the prism and the surface of the water is $\tan^{-1} \frac{1}{3}$.

5. A prism, whose section is a triangle ABC , is made of uniform material, and floats freely in water with the edge C in the surface, prove that its specific gravity is either

$$\frac{\sin A \cos B}{\sin C} \quad \text{or} \quad \frac{\sin B \cos A}{\sin C}.$$

6. A thin uniform open shell in the form of a right circular cone of vertical angle 60° floats partly immersed in water with its vertex downwards and the lowest point of its circular base just in the surface. Show that the line joining the vertex to this point makes an angle $\tan^{-1} \frac{\sqrt{3}}{5}$ with the horizontal.

[In this case the surface of the water cuts the cone in a curve called an ellipse whose centre of gravity is its middle point, the centre of gravity of the water displaced divides the straight line joining this middle point to the vertex in the ratio 1 . 3]

7. A heavy hemispherical bowl, of radius a , containing water rests on a rough inclined plane of angle α , prove that the ratio of the weight of the bowl to that of the water cannot be less than

$$\frac{2 \sin \alpha}{\sin \phi - 2 \sin \alpha},$$

where $\pi a^2 \cos^2 \phi$ is the area of the surface of the water.

8. A bucket half full of water is suspended by a string passing over a pulley small enough to let the other end fall into the bucket. To this end is tied a ball whose sp gr σ is > 2 . If the ball do not touch the bottom of the bucket and no water overflow, shew that equilibrium is possible if the weight of the ball lie between W and $\frac{\sigma}{\sigma - 2} W$, where W is the weight of the bucket and water.

9. Two buckets contain water, the mass of each with the water in it being M , and they balance one another on a smooth pulley. Two pieces of wood, of masses m and m' and specific gravities σ and σ' , are then tied to the bottoms of the buckets so that they are wholly immersed, shew that the tension of the string attached to m is

$$\frac{2m(M+m')}{2M+m+m'} g \left(\frac{1}{\sigma} - 1 \right)$$

10. A cylinder, of height h and density ρ , floats with its axis vertical in a liquid of density σ_1 , if now the density of the air increases from σ_2 to σ_3 , find by how much the cylinder will rise or sink

11. A rod floats upright partially immersed in a homogeneous liquid. Prove that a small increase of atmospheric density will produce a small rise of the rod proportional to the square of the length of the unimmersed portion

12. A cylindrical piece of cork, of height h , is floating with its axis vertical in a basin of water. If the basin be placed under the receiver of an air-pump and the air be pumped out, prove that the cork will sink through a distance $\frac{\sigma}{1-\sigma}(1-s)h$, where σ and s are respectively the specific gravities of air and cork

13. A body floating in water has volumes P_1, P_2, P_3 above the surface when the densities of the surrounding air are respectively ρ_1, ρ_2, ρ_3 , prove that

$$\frac{\rho_2 - \rho_3}{P_1} + \frac{\rho_3 - \rho_1}{P_2} + \frac{\rho_1 - \rho_2}{P_3} = 0$$

14. A composition is made of two metals, A and B , the sp grs. of which are σ_1 and σ_2 respectively. The composition weighs a ozs in air and b ozs in water. Prove that the ratio of the volumes of A and B is

$$\sigma_2(a-b) - a \quad a - \sigma_1(a-b)$$

15. A body, of density ρ , is weighed by means of weights, of density ρ' , ($\rho' > \rho$), the density of the air being σ . The density of the air increases from σ to σ' , prove that the body weighs less than before by a fraction $\frac{(\rho' - \rho)(\sigma' - \sigma)}{(\rho - \sigma)(\rho' - \sigma')}$ of its former weight

16. Assuming the sp gr of air to be 00125, and that of some brass weights to be 8.4, shew that the correction to be applied to the apparent weight of water weighed in a balance by means of these brass weights is about 1 per cent

17. A, B, C are balls of equal weight. A balances B and C when all are suspended in a liquid of density σ_1 , B balances C , A in a liquid of density σ_2 , C balances A, B in a liquid of density σ_3 . Find the sp gr of A, B , and C

18. A triangular lamina ACB , right-angled at C , floats in a liquid of $\frac{8}{9}$ ths its density, being hinged freely at C to a point fixed below its surface and with AB entirely out of the liquid. If CA make an angle of 30° with the horizon and CB be bisected by the surface of the liquid, prove that the lengths of CA, CB are as $2 \cdot \sqrt{3}$

19. A rectangular lamina, whose sides are as $\sqrt{3}$ 1, can turn freely about the middle point of one of its shorter sides and this point is fixed below the surface of the liquid. The lamina rests with its plane vertical and one diagonal in the surface of the liquid. Compare the specific gravities of the lamina and liquid, and prove that the pressure on the fixed point is two-sevenths of the weight of the lamina.

20. The corner A of a uniform square lamina $ABCD$, whose side is 5 inches long, is freely hinged at a point 4 inches below the surface of some water, and the lamina floats in equilibrium in a vertical plane with the corner B in the surface and the edge CD partly immersed. Find the sp. gr. of the lamina.

21. A rectangle movable about an angular point rests with half its area immersed in a liquid. If the angular point lie outside the liquid and the rectangle float with its sides equally inclined to the vertical, prove that the ratio of the density of the rectangle to that of the liquid is $3b + a - 4b$, where a and b are the sides of the rectangle and $a < b$.

22. A uniform rectangular lamina $ABCD$, of sp. gr. σ has its corner A fixed at a depth c below the surface of some water and the corners B and C above, and D below, the surface and it can turn freely about A . If $AB = 2b$, $AD = 2a$, find an equation for θ , the angle that AB makes with the surface in the position of equilibrium.

23. A square lamina, of density ρ , floats in water, of density σ , with its plane vertical and one angular point below the surface, if $9\sigma > 32\rho$, prove that there are three positions of equilibrium in two of which neither diagonal is vertical.

24. A solid hemisphere, which can turn freely about a fixed horizontal diameter of its plane base, just fits into a fixed hemispherical cup, whose centre is the same as that of the solid hemisphere and whose plane base is horizontal, if the hemisphere be turned through any angle, and the cup be then filled with liquid of twice the sp. gr. of the solid, prove that it will always be in equilibrium.

25. A solid cylinder hangs vertically by a heavy chain and is partially immersed in a large vessel of water. The chain passes over a smooth pulley and a suitable counterpoise is attached to the other end which hangs freely. If the diameter of the cylinder be properly adjusted, shew that the equilibrium of the cylinder is neutral, i.e. that it will rest with any length immersed.

26. A hemispherical bowl rests on the top of a sphere of double its radius, and water is slowly poured into the bowl, prove that the equilibrium will be stable until a weight of water, equal to half the weight of the bowl, has been poured in.

CHAPTER VI.

ON METHODS OF FINDING THE SPECIFIC GRAVITY OF BODIES

71. IN the present chapter we shall discuss some ways of obtaining the specific gravity of substances

To find the specific gravity of any substance with respect to water, we have to compare its weight with that of an equal volume of water

The principal methods are by the use of

- (1) The Specific Gravity Bottle,
- (2) The Hydrostatic Balance,
- (3) Hydrometers, and
- (4) The U-tube

We shall consider these four in order.

72. **Specific Gravity Bottle** This is a bottle capable of holding a known quantity of liquid. It is made in two forms. In (1) the neck of the bottle is open, and a mark is made on the neck up to the level of which the bottle is always exactly filled. In (ii) the bottle is closed by a tightly-fitting glass stopper, which is pierced by a small hole to allow the superfluous liquid to spirt out when the stopper is pushed home.

(1) *To find the specific gravity of a given liquid.*

Let the weight of the bottle when exhausted of air be w .

When filled with water and the stopper put in, let the weight be w'

When filled with the given liquid let its weight be w'' .

Then

$w' - w$ = weight of the water that would fill the bottle, and

$w'' - w$ = weight of the liquid that would fill the bottle.

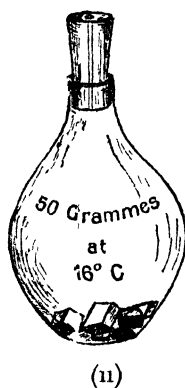
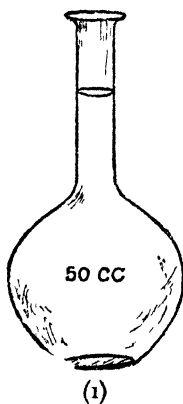

Since $w'' - w$ and $w' - w$ are the weights of equal quantities of the given liquid and water, therefore, by Art 19, the sp. gr of the liquid is

$$\frac{w'' - w}{w' - w}$$

(2) *To find the specific gravity of a given solid which is insoluble in water*

Let the solid be broken into pieces small enough to go into the bottle, and let the total weight of the pieces be W .

Put the solid into the bottle, fill it with water and put in the stopper, and weigh. Let the resulting weight be w'' . Let the weight of the bottle when filled with water only be w' .

Then

$W + w'$ = total weight of the solid and of the bottle when filled with water

Also

w'' = total weight of the solid and of the bottle when filled with water – weight of the water displaced by the solid

Hence, by subtraction,

$W + w' - w''$ = weight of the water displaced by the solid

Therefore W and $W + w' - w''$ are the weights of equal volumes of the solid and water, so that the required sp gr

$$= \frac{W}{W + w' - w''}$$

In performing the operations described some precautions must be taken and corrections made. The water should be at some definite temperature, a convenient temperature is 16°C .

If it were convenient the weighings should take place *in vacuo*. For, as explained in Art 62, the air displaced by the weights and the bodies weighed has some effect on the result of a delicate experiment. In practice the weighings take place in air and corrections are applied to the results obtained.

73 If the body be, like sugar, soluble in water, it must be placed in a liquid in which it is insoluble. In the case of sugar alcohol is a suitable liquid.

Again, potassium decomposes water, it therefore should be weighed in naphtha.

Using the notation of the last article, we have in these cases

$$\frac{\text{sp gr of the solid}}{\text{sp. gr. of the liquid}} = \frac{W}{W + w' - w''}$$

Hence, the sp gr of the liquid being known, we obtain the sp. gr. of the body

74 Ex 1 A sp gr bottle when filled with water weighs 1000 grains. If 350 grains of a powdered substance be introduced into the bottle it weighs 1250 grains. Find the sp gr of the powder.

Here $1250 = 1000 + \text{wt. of substance} - \text{wt. of the water it displaces}$

\therefore wt of water displaced = wt. of substance - 250 = 100 grains.

\therefore required sp gr = $\frac{\text{wt of substance}}{\text{wt of displaced fluid}} = \frac{350}{100} = 3.5$.

Ex. 2 The effect of the air being neglected, the sp gr. of a solid body is found by a specific gravity bottle to be σ , if a be the sp. gr of the air, shew that the real sp gr is $\sigma - a(\sigma - 1)$

Let ρ be the real sp gr of the body, V_1 its volume, and V_2 the volume of the water that the bottle would contain. Let D be the sp gr of the substance of which the "weights" are made, and w the weight of unit volume of water.

Then w' , w'' and W being the apparent weights, found as in Art 72, we have

wt in air of bottle + wt in air of the water = wt. in air of w' ,

i.e. as in Art 63,

$$\text{wt. in air of bottle} + V_2 w (1 - a) = w' \left(1 - \frac{a}{D} \right) \quad \dots (1)$$

So

wt. in air of bottle + wt. in air of $(V_2 - V_1)$ of water + wt. in air of V_1 of the substance = wt in air of w'' ,

i.e. wt. in air of bottle + $(V_2 - V_1) w (1 - a) + V_1 w (\rho - a)$

$$= w'' \left(1 - \frac{a}{D} \right) \quad (2)$$

Subtracting (1) from (2), we have

$$- V_1 w (1 - a) + V_1 w (\rho - a) = (w'' - w') \left(1 - \frac{a}{D} \right),$$

i.e. $V_1 w (\rho - 1) = (w'' - w') \left(1 - \frac{a}{D} \right) \dots \dots \dots (3)$.

Also wt in air of the substance = wt in air of W .

$$V_1 w (\rho - a) = W \left(1 - \frac{a}{D} \right) \dots \dots \dots (4).$$

Dividing (3) by (4), we have

$$\frac{\rho - 1}{\rho - a} = \frac{w'' - w'}{W}.$$

Now from Art. 72 (2), we have $\sigma = \frac{W}{W + (w' - w'')}.$

$$\therefore w'' - w' = W \cdot \frac{\sigma - 1}{\sigma}.$$

$$\therefore \frac{\rho - 1}{\rho - a} = \frac{\sigma - 1}{\sigma},$$

$$\therefore \rho\sigma - \sigma = \rho\sigma - \rho - a\sigma + a,$$

$$i.e. \rho = \sigma - a(\sigma - 1).$$

EXAMPLES. XVII.

1. A given sp. gr. bottle weighs 7.95 grains; when full of water it weighs 187.63 grains and when full of another liquid 142.71 grains. Find the sp. gr. of the latter liquid.

2. When a sp. gr. bottle is filled with water it is counterpoised by 983 grains in addition to the counterpoise of the empty bottle and by 773 grains when filled with alcohol; what is the sp. gr. of the latter?

3. A sp. gr. bottle, full of water, weighs 44 grms. and when some pieces of iron, weighing 10 grms. in air, are introduced into the bottle and the bottle is again filled up with water the combined weight is 52.7 grms. Find the sp. gr. of iron.

4. A sp. gr. bottle completely full of water weighs 38.4 grms., and when 22.3 grms. of a certain solid have been introduced it weighs 49.8 grms. Find the sp. gr. of the solid.

5. A sp. gr. bottle weighs 212 grains when it is filled with water; 50 grains of metal are put into it; the overflow of water is removed and the bottle now weighs 254 grains. Find the sp. gr. of the metal.

6. Shew that the same correction as in Art. 74, Ex. 2, is necessary if the density of a liquid be found by means of the specific gravity bottle, the effect of the air having been neglected.

75. **The Hydrostatic Balance.** This is an ordinary balance except that it has one of its pans suspended by shorter suspending arms than the other, and that it has a hook attached to this pan to which any substance can be attached.

(1) *To find the specific gravity of a body which would sink in water*

Let W be the weight of the body when weighed in the ordinary manner. Suspend the body by a fine strong thread or wire attached to the hook of the shorter arm of the scale-pan, and let the body be totally immersed in a vessel filled with water.

Put weights into the other scale-pan until the beam of the balance is again horizontal, and let w be the sum of these weights.

Then

w = apparent weight of the solid in water

= real weight of the body – the weight of the water it displaces

= W – wt of the displaced water

$W - w$ = wt of the displaced water.

Also W = wt of the solid

$$\therefore \frac{W}{W - w} = \text{required sp gr}$$

If the liquid be not water, but some other liquid, then

$$\frac{W}{W - w} = \frac{\text{sp. gr of the body}}{\text{sp. gr of the liquid}}$$

i.e. the ratio of the sp grs of the body and liquid is the ratio of the real weight of the body to the loss of weight of the body when immersed in the given liquid

(2) *To find the specific gravity of a body which would float in water*

In this case the body must be attached to another body, called a sinker, of such a kind that the two together would sink in water

Let W be the weight of the body alone,

W' the weight of the sinker alone,

w the weight of the sinker and body together when placed in water,

and w' the weight of the sinker alone in water

Then

$w =$ real wt of the sinker and body $-$ wt of the water displaced by the sinker and body (Art 62)

$= W + W' -$ wt. of water displaced by the sinker and body

$\therefore W + W' - w =$ wt of water displaced by the sinker and body (1)

So $W' - w' =$ wt of water displaced by the sinker alone. (2)

Hence, by subtraction,

$W - w + w' =$ wt of water displaced by the body alone.

Also $W =$ real wt of the body.

$\therefore \frac{W}{W - w + w'} =$ sp gr. of the body.

It will be noted that the result does not contain W' , which is the weight of the sinker, so that in practice this weight is not required

(3) *To find the specific gravity of a given liquid*

Take a body which is insoluble in the given liquid and in water, and let its actual weight be W

When suspended from the short arm of the hydrostatic balance and placed in water, let its apparent weight be w

When the given liquid is substituted for water, let the apparent weight be w' .

Then $w =$ wt. of the body $-$ wt of the water it displaces.

Hence wt of the water displaced $= W - w$.

So wt. of the liquid displaced $= W - w'$.

Hence $W - w'$ and $W - w$ are the weights of equal volumes of the liquid and water

$$\therefore \frac{W - w'}{W - w} = \text{required sp. gr.}$$

76. Jolly's Balance consists of a long spiral spring carrying two scale-pans, one above the other, and is so arranged that the lower scale-pan is in water. The spring hangs in front of a vertical divided scale. The body, whose sp. gr. is to be found, is placed in the upper scale-pan, and the point to which the spring is extended is noted by means of the scale. The body is then replaced by weights sufficient to produce the same extension as before, and the weight of the body thus determined. The body is then placed in the lower pan in the water, and extra weights placed in the upper pan till the spring has again the same extension as before. These extra weights measure the loss of weight which the body undergoes through being placed in the water, *i.e.* they are equivalent to the weight of the water displaced by the body.

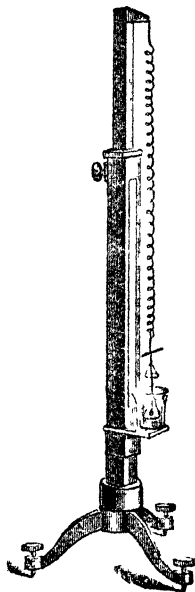

The weight of the body and the weight of the water displaced have now been found, and thus the sp. gr. is known.

77 Ex 1. *A piece of copper weighs 9000 grms in air and 7987.5 grms. when weighed in water. Find its specific gravity.*

Here

7987.5 = 9000 - wt of water displaced by the copper.

∴ wt. of displaced water = 1012.5.

∴ required sp gr. = $\frac{9000}{1012.5} = 8.8$.

Ex 2 A piece of cork weighs 30 grms in air, when a piece of lead is attached the combined weight in water is 6 grms, if the weight of the lead in water be 96 grms, what is the sp gr of the cork?

If w be the wt. of lead in air,

the wt of water displaced by the lead and cork

= $w + 30$ - combined wt in water = $w + 30 - 6 = w + 24$.

So wt of water displaced by the lead = $w - 96$

Hence the weight of water displaced by the cork

= $(w + 24) - (w - 96) = 120$.

sp gr of the cork = $\frac{30}{120} = \frac{1}{4}$.

Ex 3 If a ball of platinum weigh 20.86 ozs in air, 19.86 in water, and 19.36 in sulphuric acid, find the sp gr. of the platinum and the sulphuric acid.

Wt. of the water displaced by the platinum

= $20.86 - 19.86 = 1$ oz.

Wt. of the sulphuric acid displaced by the platinum

= $20.86 - 19.36 = 1.5$ ozs.

Hence the sp gr of the platinum = $\frac{20.86 \text{ ozs.}}{1 \text{ oz.}} = 20.86$,

and the sp. gr. of sulphuric acid = $\frac{1.5 \text{ ozs}}{1 \text{ oz.}} = 1.5$

78. If the substance whose specific gravity is to be determined is, like sugar, soluble in water or if it absorbs water, it may be coated with wax

Ex Some sugar weighing 68 grammes is coated with 11 grammes of wax whose sp. gr. is .88. If the whole weighs $26\frac{1}{2}$ grammes in water, find the sp. gr. of the sugar.

Weight of water displaced by the sugar and wax
 $= 68 + 11 - 26\frac{1}{2} = 52\frac{1}{2}$ grammes.

Weight of water displaced by the wax
 $= \frac{1}{88} \times 11 \text{ grammes} = 12\frac{1}{2}$ grammes.

\therefore weight of water displaced by the sugar
 $= 52\frac{1}{2} - 12\frac{1}{2} = 40$ grammes.

\therefore sp gr of the sugar $= \frac{64}{40} = 1.6$

EXAMPLES. XVIII

[In Exs. 1—17 the sp. gr. of the air is neglected.]

1. If a body weigh 732 grms in air and 252 grms in water, what is its sp gr?

2. A piece of flint glass weighs 24 ozs. in air and 1.6 ozs in water, find its sp gr

3. A piece of cupric sulphate weighs 3 ozs in air and 1.86 ozs in oil of turpentine. What is the sp gr of the cupric sulphate, that of oil of turpentine being .88?

4. It is required to find the sp gr of potassium which decomposes water. A piece of potassium weighing 432.5 grms in air is weighed in naphtha, the sp gr of which is .847, and is found to weigh 9 grms. What is the sp gr. of potassium?

5. A piece of lead weighs 30 grains in water. A piece of wood weighs 120 grains in air and when fastened to the lead the two together weigh 20 grains in water. Find the sp gr. of the wood.

6. A solid, which would float in water, weighs 4 lbs., and when the solid is attached to a heavy piece of metal the whole weighs 6 lbs in water, the weight of the metal in water being 8 lbs., find the sp gr of the solid.

7. A body of weight 300 grms and of sp gr 5 has 200 grms. of another body attached to it and the joint weight in water is 200 grms. Find the sp gr. of the attached substance.

8. A piece of glass weighs 47 grms in air, 22 grms. in water, and 25.8 grms. in alcohol. Find the sp. gr. of the alcohol.

9. A bullet of lead, whose sp gr. is 11.4, weighs 1.09 ozs. in air, and 1 oz in olive oil. Find the sp gr. of the olive oil.

10. A ball of glass weighs 665.8 grammes in air, 465.8 grammes in water and 297.6 grammes in sulphuric acid. What is the sp. gr. of the latter?

11. A piece of sugar weighing 40 grammes is coated with 5.76 grammes of wax whose sp. gr. is .96. If the whole weighs 14.76 grammes in water, find the sp. gr. of the sugar.

12. Some copper weighs 72 grammes and is coated with 18 grammes of wax whose sp. gr. is .9. If the whole weighs 62 grammes in water, find the sp. gr. of the copper.

13. A piece of marble, of sp. gr. 2.84, weighs 92 grms. in water and 98.5 grms. in oil of turpentine. Find the sp. gr. of the oil and the volume of the marble.

14. A body is weighed in two liquids, the first of sp. gr. .8 and the other of sp. gr. 1.2. In the two cases its apparent weights are 18 and 12 grms. respectively. Find its true weight and sp. gr.

15. The apparent weight of a sinker when weighed in water is 5 times the weight in vacuo of a portion of a certain substance; the apparent weight of the sinker and substance together is 4 times the same weight, find the sp. gr. of the substance.

16. A given body weighs 4 times as much in air as in water and one-third as much again in water as in another liquid. Find the sp. gr. of the latter liquid.

17. The crown used by the Stuart Sovereigns which was destroyed in the 17th century was said to have been made of pure gold (sp. gr. = 19.2) and to have weighed $7\frac{1}{2}$ lbs. How much would it weigh in water?

If it had been of alloy, partly silver (sp. gr. = 10.5) and partly gold, and had weighed $7\frac{1}{4}$ lbs. in water, how much of each metal would it have contained?

18. The sp. gr. of a body found by the Hydrostatic Balance, the observation being in air and its effect neglected, is σ , prove that this result is really too great by $a(\sigma - 1)$, where a is the sp. gr. of air.

79. Hydrometers. A hydrometer is an instrument which, by being floated in any liquid, determines the sp. gr. of the liquid. There are various forms of the hydrometer, we shall consider two, viz. the Common Hydrometer and Nicholson's Hydrometer.

80. Common Hydrometer. This consists of a straight glass stem ending in a bulb, or bulbs, the lower of which is loaded with mercury to make the instrument float with its stem vertical.

To find the specific gravity of a given liquid

When immersed in the given liquid, let the instrument float with the point *D* of the stem at the surface of the liquid.

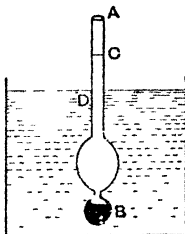

When immersed in water, let it float with the point *C* of the stem in the surface of the water

Let V be the total volume of the instrument and a the area of the section of the stem, this section being constant throughout the stem

When immersed in the first liquid, the portion of the stem, whose length is AD and whose volume is $a \cdot AD$, is out of the liquid. The volume immersed is therefore

$$V - a \cdot AD$$

Similarly, when placed in water, the volume immersed is

$$V - a \cdot AC.$$

In each case the weights of the displaced liquids are equal to the weight of the instrument, so that the weights of the liquids are the same.

Hence, if s be the sp gr of the liquid, we have

$$s(V - a \cdot AD) = V - a \cdot AC.$$

$$\therefore s = \frac{V - a \cdot AC}{V - a \cdot AD}.$$

In practice the instrument maker sends out the common hydrometer graduated by marking along its stem at different points the sp grs of the liquids in which the given instrument would sink to these points

A hydrometer to shew the sp grs of liquids of all densities would have to be inconveniently long. Hydrometers are therefore usually made in sets to be used for liquids specifically lighter than water, for medium liquids, and for very heavy liquids respectively

81. Let O be a point on the stem of the hydrometer, produced if necessary, such that the volume of the length AO of the tube is equal to V , the total volume of the hydrometer

Hence $V = a \cdot AO.$

The result of the previous article then gives

$$\begin{aligned} s &= \frac{V - a \cdot AC}{V - a \cdot AD} \\ &= \frac{a \cdot AO - a \cdot AC}{a \cdot AO - a \cdot AD} \\ &= \frac{OC}{OD} \end{aligned}$$

Hence

$$OD = \frac{OC}{s}.$$



The hydrometer may be then theoretically graduated thus; Let C be the point at which the instrument would float in water, let O be the point on the stem or stem produced, such that the volume of the length OC of the stem is equal to that of the water displaced by the instrument when floating in water, then the graduation D corresponding to any sp gr s is given by

$$OD = \frac{OC}{s}.$$

It follows that for values of the sp gr s in Arithmetical Progression the distances OD are in Harmonical Progression, whilst if the distances OD are in A.P. the corresponding sp gr are in H.P.

There are thus two types of the common hydrometer,

(1) Twaddell's hydrometer, used in England. Here the values of s ascend in A.P. (*eg* 1, 1.025, 1.05, 1.075,) and the corresponding values of OD descend in H.P., so that the marks of graduation become closer together the lower they are on the tube

(2) Beaumé's hydrometer, used on the Continent. Here the values of OD are in A.P. so that the distances between the marks of graduation are the same, the corresponding values of s are now in H.P.

82 Ex 1 *The whole volume of a common hydrometer is 6 cubic inches and the stem, which is a square, is $\frac{1}{8}$ inch in breadth, it floats in one liquid with 2 inches of its stem above the surface and in another with 4 inches above the surface. Compare the specific gravities of the liquids.*

In the first liquid the volume immersed

$$= 6 - 2 \frac{1}{8^2} = \frac{191}{32} \text{ cub. ins.}$$

In the second liquid the volume immersed

$$= 6 - \frac{4}{32} = \frac{190}{32} \text{ cub. ins.}$$

Hence, if s_1 and s_2 be the required specific gravities, we have

$$\frac{191}{32} \cdot s_1 = \frac{190}{32} \cdot s_2.$$

$$\therefore s_1 : s_2 = 190 : 191.$$

Ex 2 *The stem of a common hydrometer is cylindrical, and the highest graduation corresponds to a specific gravity of 1 whilst the lowest corresponds to 1.2. What specific gravity will correspond to a point exactly midway between these divisions?*

Take the notation of Art 81. Let C and D be the points which are in the surface of the liquid when the specific gravity of the latter is 1 and 1.2 respectively, so that $OD = \frac{OC}{1.2}$ (1)

Let D_1 be the point half-way between C and D , and σ the corresponding specific gravity, so that $OD_1 = \frac{OC}{\sigma}$ (2)

$$\therefore \frac{OC}{\sigma} = OD_1 = \frac{1}{2}(OC + OD) = \frac{1}{2} \left[OC + \frac{OC}{1.2} \right].$$

$$\frac{2}{\sigma} = 1 + \frac{5}{6} = \frac{11}{6}, \text{ so that } \sigma = \frac{12}{11} = 1.09$$

This result it will be noted is not half-way between 1 and 1.2

More generally, if s_1 and s_2 be the specific gravities corresponding to any two graduations of the common hydrometer, then the sp. gr., s , corresponding to the graduation which is half way between these two, is given by

$$\frac{2}{s} = \frac{1}{s_1} + \frac{1}{s_2}$$

83. Nicholson's Hydrometer. This hydrometer consists of a hollow metal vessel A which supports by a thin stem a small pan B on which weights can be placed. At its lower end is a small heavy cup or basket C , which should be heavy enough to ensure stable equilibrium when the instrument is floated in a liquid

The instrument may be used to compare the sp. grs. of two liquids and also to find the sp. gr. of a solid

On the stem is a well-defined mark D , and the method consists of loading the instrument till it sinks so that this mark is in the surface of the two liquids to be compared.

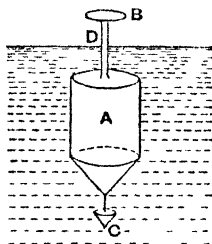

(1) *To find the sp gr. of a given liquid*

Let W be the weight of the instrument. Let w be the weight that must be placed on the pan B , so that the point D of the instrument may float in the level of the given liquid.

Let w_1 be the weight required when water is substituted for the given liquid

In the first case it follows, by Art 57, that $W + w$ is the weight of the liquid displaced by the instrument.

So $W + w_1$ is the weight of the water displaced by the instrument

Hence $W + w$ and $W + w_1$ are the weights of equal volumes of the given liquid and water

The required sp gr. therefore = $\frac{W + w}{W + w_1}$.

(2) *To find the sp gr. of a solid body*

Let w_1 be the weight which when placed in the pan B will sink the instrument in water to the point D

Place the solid upon the pan and let the weight now required to sink the instrument to D be w_2 .

The weight of the solid therefore = $w_1 - w_2$.

Now place the solid in the cup *C* underneath the water, and let w_3 be the weight that must be placed in *B* to sink the instrument to *D*.

The wt of the solid together with w_2 has therefore the same effect as the wt. of the solid in water together with w_3

$$\cdot \text{ wt of the solid} + w_2$$

$$= \text{ wt. of the solid in water} + w_3$$

$$\therefore w_3 - w_2 = \text{ wt of the solid} - \text{ wt of the solid in water}$$

$$= \text{ wt of the water displaced by the solid}$$

(Art 62)

Also $w_1 - w_2 = \text{ wt of the solid}$

$$\therefore \frac{w_1 - w_2}{w_3 - w_2} = \text{ the required sp gr.}$$

It will be noted that a Nicholson's Hydrometer always displaces a constant *volume* of liquid, whilst the Common Hydrometer always displaces a constant *weight* of liquid

84 Ex *A Nicholson's Hydrometer when loaded with 200 grains in the upper pan sinks to the marked point in water, a stone is placed in the upper pan and the weight required to sink it to the same point is 80 grains, the stone is then placed in the lower pan and the weight required is 128 grains, find the sp gr of the stone*

The weight of the hydrometer being *W* grains, the weight of the fluid displaced is equal to

$$(i) \quad W + 200,$$

$$(ii) \quad W + 80 + \text{wt of stone},$$

and $(iii) \quad W + 128 + \text{wt of stone in water}.$

$$\therefore W + 200 = W + 80 + \text{wt of stone}$$

$$= W + 128 + \text{wt. of stone in water.}$$

$$\therefore 120 = \text{wt. of stone} \quad \dots \dots (1)$$

$$72 = \text{wt of stone in water}$$

$$= 120 - \text{wt of water displaced by stone} \quad (2)$$

$$\therefore \text{ required sp. gr.} = \frac{\text{wt of stone}}{\text{wt. of water displaced by stone}} = \frac{120}{120 - 72}$$

$$= \frac{120}{48} = \frac{5}{2} = 2.5.$$

EXAMPLES. XIX.

1. A common hydrometer weighs 2 ozs and is graduated for sp. grs. varying from 1 to 1.2. What should be the volumes in cubic ins. of the portions of the instrument below the graduations 1, 1.1, and 1.2 respectively?

2. When a common hydrometer floats in water $\frac{9}{10}$ ths of its volume is immersed, and when it floats in milk $\frac{90}{103}$ of its volume is immersed, what is the sp. gr. of milk?

3. A hydrometer floats in a liquid of sp. gr. 1.2 and then 4 inches of its stem are exposed, if in a liquid of sp. gr. 1.4 eight inches are exposed, how much will be exposed if it floats in a liquid of density 1.3?

4. The sp. gr. corresponding to the lowest mark on the stem of a hydrometer is 1.6. What is the sp. gr. corresponding to the highest mark if the reading half way between the two is 1.3?

5. The volume of a common hydrometer is 12 cub. cms and its weight is 9 grammes. How much of it will be unimmersed when it is put into a liquid of sp. gr. 85?

6. A common hydrometer has a small portion of its bulb rubbed off from frequent use. In consequence when placed in the water it appears to indicate that the sp. gr. of water is 1.002, find what fraction of its weight has been lost.

7. There are three liquids *A*, *B*, *C*; a hydrometer of variable immersion is placed in them successively, it floats with 2 inches of its stem out of *A*, with 3 inches out of *B*, and 4 inches out of *C*, the sp. gr. of *A* being 8 and that of *B* 85, what is the sp. gr. of *C*?

8. A Nicholson's Hydrometer weighs 8 ozs. The addition of 2 ozs to the upper pan causes it to sink in one liquid to the marked point, while 5 ozs are required to produce the same result in another liquid. Compare the sp. grs. of the liquids.

9. A Nicholson's Hydrometer, of weight $4\frac{3}{4}$ ozs, requires weights of 2 and $2\frac{3}{8}$ ozs respectively to sink it to the fixed mark in two different liquids. Compare the sp. grs. of the two liquids.

10. A Nicholson's Hydrometer is of weight $3\frac{3}{4}$ ozs., and a weight of $1\frac{1}{4}$ ozs. is necessary to sink it to the fixed mark in water. What weight will be required to sink it to the fixed mark in a liquid of density 2.2?

11. A certain solid is placed in the upper cup of a Nicholson's Hydrometer, and it is then found that 12 grains are required to sink the instrument to the fixed mark, when the solid is placed in the lower cup 16 grains are required, and when the solid is taken away altogether 22 grains are required, find the sp. gr of the solid

12. The standard weight of a Nicholson's Hydrometer is 1250 grains. A small substance is placed in the upper pan and it is found that 530 grains are needed to sink the instrument to the standard point, when the substance is placed in the lower pan 620 grains are required. What is the sp. gr. of the substance?

13. In a Nicholson's Hydrometer if the sp. gr of the weights be 8, what weight must be placed in the lower pan to produce the same effect as 2 ozs in the upper pan?

14. The sp gr of a body found by a Nicholson's Hydrometer is σ when the effect of the air is neglected, prove that the real sp gr is $\sigma - s(\sigma - 1)$, where s is the specific gravity of air. Also, if W be the apparent weight of the body as found from the experiment, find its real weight

Let D and ρ be the real sp gr of the "weights" and the body, let w_1, w_2, w_3 be as in Art 83, and let W_1 be the real weight of the body and W_2 the weight of the instrument

As in Art 83, $W = w_1 - w_2$ and $\sigma = \frac{w_1 - w_2}{w_3 - w_2}$.

The experiment being performed as in Art 83, we have

$$W_2 + w_1 \left(1 - \frac{s}{D}\right) = \text{wt of the water displaced,}$$

$$W_2 + w_2 \left(1 - \frac{s}{D}\right) + W_1 \left(1 - \frac{s}{\rho}\right) = \text{wt of the water displaced,}$$

and $W_2 + w_3 \left(1 - \frac{s}{D}\right) + W_1 \left(1 - \frac{1}{\rho}\right) = \text{" " " " " "}$

, by subtraction, $W_1 \left(1 - \frac{s}{\rho}\right) = (w_1 - w_2) \left(1 - \frac{s}{D}\right)$ (1),

and $W_1 \left(\frac{1-s}{\rho}\right) = (w_3 - w_2) \left(1 - \frac{s}{D}\right)$ (2)

. , by division, $\frac{\rho - s}{1 - s} = \frac{w_1 - w_2}{w_3 - w_2} = \sigma$

$\therefore \rho = s + \sigma(1 - s) = \sigma - s(\sigma - 1)$.

Also (1) gives

$$\begin{aligned} W_1 &= W \frac{1 - \frac{s}{D}}{1 - \frac{s}{\rho}} = \frac{W \left(1 - \frac{s}{D}\right)}{\rho - s} \rho \\ &= \frac{W \left(1 - \frac{s}{D}\right)}{\sigma(1-s)} [\sigma - s(\sigma - 1)] \\ &= W \left(1 - \frac{s}{D}\right) \left[1 + \frac{s}{\sigma(1-s)}\right]. \end{aligned}$$

[We have neglected the weight of the air displaced by the unimmersed portion of the instrument, this is constant and thus, like W_2 , does not appear in equations (1) and (2).]

15. If a common hydrometer be accurately graduated for use in a vacuum, show that the error due to using it in air of sp gr σ will be an apparent increase of σ' of specific gravity, where σ' is to σ in the ratio of the volume of the hydrometer unimmersed to that immersed.

16. A common hydrometer has a portion of its bulb chipped off, and when placed in liquids of densities α, β, γ it indicates densities α', β', γ' respectively, prove that

$$\gamma = \frac{\gamma' \alpha \beta (\alpha' - \beta')}{\alpha \beta (\alpha - \beta) - \gamma' (\alpha \beta' - \alpha' \beta)}.$$

85. U tube method. If two liquids do not mix there is another method, by using a bent tube, of comparing their sp. grs.

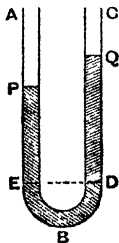

ABC is a bent tube having a uniform section and straight legs

The two liquids are poured into the two legs and rest with their common surfaces at D , and with the surfaces in contact with the air at P and Q .

Let D be in the leg BC and E the point of the leg AB which is at the same level as D

Let s_1 and s_2 be the sp grs. of the liquids

If w be the weight of a unit volume of the standard substance, the pressures at E and D are respectively

$$s_1 \cdot w \cdot EP + \Pi \text{ and } s_2 \cdot w \cdot DQ + \Pi,$$

where Π is the pressure of the air

For equilibrium these two pressures must be the same .

$$\therefore s_1 \cdot w \cdot EP + \Pi = s_2 \cdot w \cdot DQ + \Pi.$$

$$\therefore \frac{s_1}{s_2} = \frac{DQ}{EP},$$

\therefore the sp grs of the two liquids are inversely as the heights of their respective columns above the common surface.

EXAMPLES. XX.

1. The lower portion of a U tube contains mercury. How many inches of water must be poured into one leg of the tube to raise the mercury one inch in the other, assuming the sp gr. of mercury to be 13.6?

2. Water is poured into a U tube, the legs of which are 8 inches long, till they are half full. As much oil as possible is then poured into one of the legs. What length of the tube does it occupy, the sp. gr of oil being $\frac{2}{3}$?

3. A uniform bent tube consists of two vertical branches and of a horizontal portion uniting the lower ends of the vertical portions. Enough water is poured in to occupy 6 inches of the tube and then enough oil to occupy 5 inches is poured in at the other end. If the sp. gr of the oil be $\frac{1}{2}$, and the length of the horizontal part be 2 inches, find where the common surface of the oil and water is situated.

4. The lower portion of a U tube contains mercury. Some liquid is poured into one of the limbs until it occupies 8 inches of the tube. If the difference of the levels in the two limbs is found to be 7 inches and the sp. gr. of mercury is 13.6, what is the sp. gr. of the liquid?

5. The lower ends of two vertical tubes, whose cross sections are 1 and 1 square inches respectively, are connected by a tube and this tube and the two vertical tubes contain mercury of sp. gr. 13.596. How much water must be poured into the larger tube to raise the level of the mercury in the smaller tube by one inch?

6. A U tube, the sections of whose arms are 2 sq. cms., and 1 sq. cm. respectively, is placed with its arms vertical and above the bend. A quantity of mercury, whose sp. gr. is 13.65, is poured into the tube and 52 cub. cms. of water are then poured into the wider arm. Through what distance will the addition of the water cause the mercury in this arm to descend?

7. A U tube of cross section a with equal vertical legs contains a liquid of density ρ . In the liquid on one side there is floating freely a solid body of volume ab and density $\sigma (< \rho)$. The length of the other leg unoccupied by liquid is c . Another liquid of density $\tau (< \sigma)$ is then poured into the leg in which the solid is floating till that leg is full. Shew that the length which is still unoccupied of the other leg is

$$b \frac{\tau(\rho - \sigma)}{\rho(2\rho - \tau)} + 2c \frac{\rho - \tau}{2\rho - \tau}.$$

86. **Hare's Hydrometer.** This instrument consists of two hollow vertical tubes connected by a hollow horizontal tube Q , from the latter proceeds a small tube which can be secured by a stopper or other contrivance.

The two vertical tubes have their ends placed in the two liquids A and B , whose sp. grs. are to be compared.

By attaching an air-pump at R , or by simple suction, a certain quantity of air is drawn out, so that the pressure of the air is reduced from the atmospheric pressure Π to a pressure Π' .

The liquids then rise in the two tubes to some such levels as E and F .

Let C and D denote the corresponding levels in the vessels A and B and let the heights CE and DF be measured. Let s_1, s_2 be the sp. grs of the liquids in the vessels A and B .

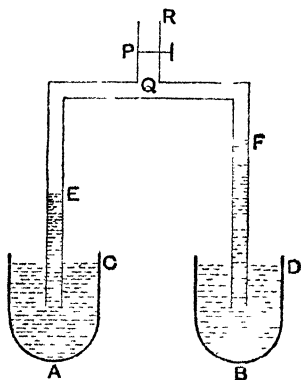

By Art 31, we then have

$$\Pi = \Pi' + ws_1 \cdot CE,$$

and

$$\Pi = \Pi' + ws_2 \cdot DF$$

$$\therefore s_1 \cdot CE = s_2 \cdot DF,$$

i.e.

$$\frac{s_2}{s_1} = \frac{CE}{DF},$$

giving the ratio of the sp grs of the two liquids

If s_1 be a known liquid, say water, then s_2 is thus found

It is clear that the method of Hare's Hydrometer is that of an inverted U tube

87. Specific gravity Balls. A method often adopted to find the sp. gr. of a liquid is to use small glass balls, loaded with mercury, the load being so adjusted that each ball just floats in a liquid of a definite sp. gr. If a number of these balls be put into a liquid, some will float and some will sink. Probably no ball will exactly float; but generally there is not much difficulty in finding one ball will just sink, and another ball which will float with not quite all its volume immersed. The required sp. gr. of the liquid will lie between the sp. grs. denoted by these two.

CHAPTER VII.

ON GASES.

88 We have pointed out in Art 3 that the essential difference between gases and liquids is that the latter are practically incompressible whilst the former are very easily compressible

The pressure of a gas is measured in the same way as the pressure of a liquid. In the case of a liquid the pressure is due to its weight and to any external pressure that may be applied to it. In the case of a gas, however, the external pressure to which the gas is subjected is, in general, the chief cause which determines the amount of its pressure

89. Air exerts a pressure. This may be seen from several experiments,

(1) If we put a bladder of air into the receiver of an air-pump and exhaust the air from the receiver, the pressure of the air inside the bladder is no longer counteracted by that of the air outside the bladder, the bladder increases in size and finally bursts.

(2) If we push a glass tumbler mouth downwards into water, it will be seen that the level of the water inside the tumbler is lower than that outside, the pressure of the imprisoned air forces the water down.

(3) An experiment known as that of the Magdeburgh hemispheres was first made in the middle of the seventeenth century. Two hollow hemispheres were fitted together very accurately, so that they were air-tight. The hollow inside was then exhausted of air. It was then found that very great force was necessary to separate the hemispheres. If they are a foot in diameter, the force to be exerted on each is more than 1600 lbs wt.



90. Air has weight This may be shewn experimentally as follows

Take a hollow glass globe, closed by a stopcock, and by means of an air-pump (Art. 137), or otherwise, exhaust it of air, and weigh the globe very carefully

Now open the stopcock, and allow air at atmospheric pressure to enter the globe, and again weigh the globe very carefully.

The globe appears to weigh more in the second case than it does in the first case. This increase in the weight is due to the weight of the air contained in the globe.

The sp. gr. of air referred to water is found to be $\cdot 001293$, i.e. the weight of a cubic foot of air is about 1.293 ounces.

So at a pressure of 76 cms. of mercury the density of dry air is $\cdot 001293$ grammes per cub cm.

$$\cdot 001293 = \frac{1}{773} \text{ nearly.}$$

91. It may be similarly shewn that any other gas has weight and pressure

The following are the specific gravities of some principal gases at 0°C and a pressure of 76 cms of mercury.

Air	$\cdot 001293$.
Oxygen	$\cdot 001430$.
Hydrogen	000089 .
Nitrogen	001256 .
Carbonic Acid	001977

Hydrogen is hence about one-fourteenth as heavy as air, and thus is very useful for filling balloons, Carbonic acid gas is much heavier than air, and it may be poured like a liquid from one vessel into another.

92. Pressure of the atmosphere.

Take a glass tube, 3 or 4 feet long, closed at one end B and open at the other end A . Fill it carefully with mercury. Invert it and put the open end A into a vessel $DEFG$ of mercury, whose upper surface is exposed to the atmosphere. Let the tube be vertical.

The mercury inside the tube will be found to descend till its surface is at a point C whose height above the level H of the mercury in the vessel is about 29 or 30 inches

For clearness suppose the height to be 30 inches. The pressure on each square inch just inside the tube at H is therefore equal to the weight of the superincumbent 30 inches of mercury.

But the pressure at *II* just inside the tube is equal to the pressure at the surface of the mercury in the vessel, which

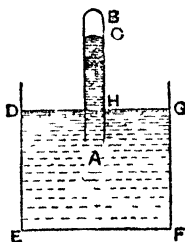

again is equal to the pressure of the atmosphere in contact with it

Hence in our case the pressure of the atmosphere is the same as that produced by a column of mercury 30 inches high

This experiment is often referred to as Torricelli's experiment, and the vacuum above *C* is often called Torricelli's vacuum

If the height of the column of mercury inside the tube be carefully noted, it will be found to be continually changing. Hence it follows that the pressure of the atmosphere is continually changing. It is, in general, less when the atmosphere has in it a large quantity of vapour.

93. The pressure of the atmosphere may, when the height of the column *HC* is known, be easily expressed in lbs. wt. per sq foot or sq inch.

For the density of pure mercury is 13.596 times that of water, *i.e.* it is 13596 ounces per cubic foot.

When the height of the column HC is 30 inches, the pressure of the atmosphere per sq inch

= wt of 30 cubic inches of mercury

$$= 30 \times \frac{13596}{1728 \times 16} \text{ lbs wt.}$$

$$= 14.75 \text{ lbs. wt.}$$

Similarly in centimetre-gramme units, if the height of the column be 76 cms., the pressure of the atmosphere per sq cm = wt of 76 cub cms of mercury

= wt of $76 \times 13\,596$ cub cms of water

$$= 76 \times 13\,596 \text{ grammes wt.}$$

$$= 1033\,296 \text{ grammes wt.}$$

$$= 1013663\,376 \text{ dynes}$$

94 *Standard atmospheric pressure* The atmosphere is said to be at standard pressure when the height of the column of the mercury barometer is 76 centimetres and the temperature is 0°C . This corresponds to a pressure, as in the previous article, of about 1013663 dynes per square centimetre

In England the height for the standard pressure is usually taken to be 30 inches (= 76.2 cms. nearly). The corresponding pressure is 14.75 lbs wt per sq foot.

This standard pressure, depending as it does upon the weight of a certain quantity of mercury, is not the same at all points of the Earth's surface (*Dynamics*, Art. 70). Hence it has been suggested that it would be well to take a pressure of one million dynes (*i.e.* a mega-dyne) per square centimetre as the standard pressure. This would correspond to a barometric height which

$$= \frac{1000000}{981 \times 13.596} \text{ cms.} = 75 \text{ cms. very nearly.}$$

Large pressures are often expressed in terms of the pressure of the atmosphere as the unit.

95. Height of the Homogeneous Atmosphere.

If the atmosphere were homogeneous, which it is very far from being, it would be easy to calculate its height. The height however of that atmosphere which, if it were of the same density as the air at the earth's surface, would give the same pressure at the earth's surface as the actual atmosphere does, is called the height of the homogeneous atmosphere.

The sp gr. of air is about 0013, so that its weight per cubic foot = 0013 times the wt. of a cubic foot of water = about $0013 \times 62\frac{1}{2}$ lbs wt

If h be the required height of the homogeneous atmosphere in feet, then

$$h \times \text{density of air} = \text{ht. of mercury barometer} \\ \times \text{density of mercury.}$$

$$\therefore h = \frac{\text{density of mercury}}{\text{density of air}} \times \text{height of the mercury barometer}$$

$$= \frac{13\ 596}{\cdot 0013} \times \frac{30}{12} \text{ feet}$$

$$= 26146 \text{ feet nearly}$$

$$= \text{nearly five miles.}$$

The pressure at any point of the earth's surface is thus roughly equal to what it would be if the atmosphere were throughout of the same density as it is at the earth's surface, and if it were 5 miles in height

96. Barometer. The Barometer is an instrument for measuring the pressure of the air. In its simplest form it consists of a tube and reservoir similar to that used in

the experiment of Art 92, and contains liquid supported by atmospheric air. The pressure is measured by the height of the liquid inside the tube above the level of the liquid in the reservoir.

The liquid generally employed is mercury, on account of its great density. Glycerine is sometimes used instead

The ordinary height of the mercury barometer is between 29 and 30 inches.

If water were used, the height would be about 33 to 34 feet.

97. Siphon Barometer. The usual form of a barometer in practice is a bent tube ABC , the diameter of the long part AB being considerably smaller than that of the short part BC . It is placed so that the two portions of the tube are vertical.

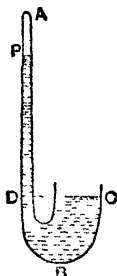

The end of the short limb is exposed to the atmosphere, and the end A of the long limb is closed. The long limb is usually about 3 feet long and inside the tube is a quantity of mercury. Above the mercury in the long limb there is a vacuum.

When the surfaces of the mercury in the two limbs are at P and C respectively, the pressure of the air is measured by the weight of a column of mercury whose height is equal to the vertical distance between P and C , i. e. to the vertical distance PD where D is a point on the long limb at the same level as C .

For, since there is a vacuum above P , the pressure at D is equal to the weight of a column of mercury of height DP .

Again, since C and D are at the same level, the pressures at these two points are the same, also the pressure of the mercury at C is equal to the pressure of the atmosphere. Hence the pressure of the atmosphere is equal to the weight of the column DP .

The tube DI is marked at regular intervals with numbers shewing the height of the barometer corresponding to each graduation.

98. Graduation of a barometer In graduating a barometer there is one important point to be taken into consideration, and that is that if the level of the mercury in BA rises the level of that in BC must fall. The required height of the barometric column is always the difference between these two levels.

Suppose the section of the part BA to be uniform and equal to $\frac{1}{10}$ th of a square inch, and that the section of the larger tube near C is uniform and equal to one square inch.

Also suppose that the level of the mercury in the smaller tube appears to rise one inch. Since the increase of the volume of mercury in one tube corresponds to a decrease in the other, it follows that the level of the mercury in the shorter tube has fallen $\frac{1}{10}$ th of an inch.

Hence the height between the two levels has increased by $(1 + \frac{1}{10})$, i.e. $\frac{11}{10}$ ths of an inch. Therefore an apparent increase of one inch in the height of the mercury does, in our case, correspond to a real increase of $\frac{11}{10}$ ths of an inch.

So an apparent increase of $\frac{10}{11}$ inch corresponds to a real increase of one inch.

To avoid the trouble of having to make this correction, the tube BA is divided into intervals of $\frac{10}{11}$ inch, and the markings are made as if these intervals are really inches.

More generally Let the long limb be of sectional area A and the short limb of sectional area A' , and suppose both A and A' to be constant.

A rise of x in the level of the mercury in the long limb would cause a fall of $\frac{A}{A'}x$ in the short limb.

Hence an apparent increase of x in the height of the barometric column would correspond to a real increase of $x + \frac{A}{A'}x$, i.e. of $\frac{A + A'}{A'}x$.

So an apparent increase of $\frac{A'}{A + A'}x$ would correspond to a real increase of x .

Hence, to ensure correctness, the distances between the successive graduations in the long limb are shorter than they are marked in the ratio $A' : A + A'$.

If the barometer is not so graduated, but has the distances between the graduations marked at their true value, then to get the true height from the apparent height we must multiply the latter by $1 + \frac{A}{A'}$. This is known as the *Correction for the Capacity of the Cistern*.

99. Correction for Temperature. Mercury expands with heat, and therefore its density diminishes; so also does the measuring rod, usually made of brass, which measures the apparent height of the mercury. For accurate measurements it is therefore necessary to choose some standard temperature, for the higher the temperature the less the weight of a certain length of mercury. This standard temperature is usually the freezing point of water.

Let h be the observed height of the mercury at temperature t° Centigrade, and let h_0 be the corresponding height at 0°C .

If a (= about 00018) be the coefficient of expansion of mercury per degree Cent, we have

$$\begin{aligned} h_0[1 + at] &= h. \\ \therefore h_0 &= \frac{h}{1 + at} \\ &= h(1 + at)^{-1} = h(1 - at), \end{aligned}$$

approximately, by the Binomial Theorem, since a is very small.

Again, if the divisions of the scale are true inches at 0°C , and if β be the coefficient of linear expansion of the scale, then h apparent inches are really $h(1 + \beta t)$ inches at $t^\circ\text{C}$.

$$\begin{aligned} \therefore h_0 &= h(1 - at) \text{ apparent inches} \\ &= h(1 + \beta t)(1 - at) \text{ real inches} \end{aligned}$$

Now, in the case of brass, β is very small, and = about 000019.

$$\begin{aligned} \therefore h_0 &= h[1 - (a - \beta)t - a\beta t^2] \\ &= h[1 - (a - \beta)t] \text{ nearly.} \end{aligned}$$

$$\begin{aligned} \text{Also} \quad a - \beta &= \cdot 00018 - 000019 \\ &= 00016 \text{ nearly.} \\ \therefore h_0 &= h - \cdot 00016 \times h \times t. \end{aligned}$$

Thus from the apparent height h must be subtracted the small quantity

$$00016 \times h \times t.$$

In a similar manner it could be shewn that the correction for temperatures Fahrenheit is $-00009(t-32)h$ nearly, at temperature t° F.

This correction is often made by the help of tables which give its value for all ordinary temperatures, and barometric heights.

100. *Correction for unequal intensity of gravity.* When barometric observations extending over a large area are compared, a correction must be applied for the unequal intensity of gravity. It is usual to reduce these observations to sea-level in latitude 45° . It could be shewn that

$$g = g_0[1 - 00257 \cos 2\lambda - 1.96 \times h \times 10^{-9}],$$

where g is the intensity of gravity at the given place, whose latitude is λ and whose height is h centimetres above the sea-level, and g_0 is its value at the sea-level in latitude 45° .

The observed height must thus be multiplied by

$$1 - 00257 \cos 2\lambda - 1.96 \times h \times 10^{-9}$$

to reduce it to sea level in latitude 45° .

101 There are also other corrections due to Capillarity and Vapour Pressure

On account of capillarity, the top of the mercury in the tube is not flat but is convex

The mercury in the tube gives off a certain amount of vapour, and its pressure tends to depress the column.

These two sources of error are however both very small in the case of a mercury barometer.

In the case of a water-barometer the vapour-pressure is of much more importance

102. Aneroid Barometer. This is a form of barometer where there is no column of mercury or other liquid. In it the varying pressure of the atmosphere is shewn by its varying effect on the thin metallic cover of a closed and partially exhausted chamber or box. The motion of this cover is by means of levers magnified and communicated to an index which shews the change of pressure. The graduation of this instrument is made by comparing it with a standard mercury barometer.

The aneroid barometer can be made of small size and weight, and its portability is a very important advantage. But it cannot be made to be as accurate as the mercury barometer.

EXAMPLES. XXI.

1. At the bottom of a mine a mercurial barometer stands at 77.4 cm., what would be the height of an oil barometer at the same place, the sp. grs. of mercury and oil being 13.596 and .9?

2. If the height of the water barometer be 1033 cms., what will be the thrust on a circular disc whose radius is 7 cms. when it is sunk to a depth of 50 metres in water?

3. Glycerine rises in a barometer tube to a height of 26 ft. when the mercury barometer stands at 30 ins. The sp. gr. of mercury being 13.6, find that of glycerine.

If an iron bullet be allowed to float on the mercury in a barometer, how would the height of the mercury be affected?

4. The diameter of the tube of a mercurial barometer is 1 cm. and that of the cistern is 4.5 cms. If the surface of the mercury in the tube rise through 2.5 cms., find the real alteration in the height of the barometer.

5. The diameter of the tube of a mercurial barometer is $\frac{1}{8}$ in. and that of the cistern is $1\frac{1}{2}$ ins. When the surface of the mercury rises 1 in., find the real alteration in the height of the barometer.

103. *Connection between the pressure and density of a gas*

It is easy to shew that the density of a gas alters when its pressure alters

Take an ordinary glass tumbler, and immerse it mouth downwards in water, taking care always to keep it vertical. As the tumbler is pushed down into the water the latter rises inside the tumbler, shewing that the volume of the air has been reduced.

Also the pressure of the contained air, being equal to the pressure of the water with which it is in contact, is greater than the pressure at the surface of the water. Also the pressure at the surface of the water is equal to atmospheric pressure, which was the original pressure of the contained air. Hence we see that whilst the contained air is compressed its pressure is increased.

Consider again the case of a boy's pop-gun. To expel the bullet the boy sharply pushes in the piston of the gun, thereby reducing the volume of the air considerably, since the bullet is expelled with some velocity the pressure of the air behind it must be increased when the volume of the air is reduced.

As another example take a bladder with very little air in it but tied so that this air cannot escape. Place the bladder under the receiver of an air-pump and exhaust the air. As the air gets drawn out its pressure on the bladder becomes less, the air inside the bladder is therefore subject to less pressure, and in consequence expands and causes the bladder to swell out.

The relation between the pressure and the volume of a gas is given by an experimental law known as **Boyle's Law**, which says that

The pressure of a given quantity of gas, whose temperature remains unaltered, varies inversely as its volume

This Law is generally known on the Continent under the name of Marriotte's Law

104. In the case of air the law may be verified experimentally as follows

ABC is a bent tube of uniform bore of which the arms BA and BC are straight. The arm BC is much longer than BA

At A let there be a small plug or cap which can be screwed in so as to render the tube BA air-tight.

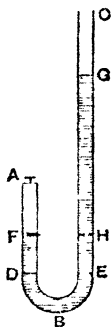

First let this cap be unscrewed. Pour in mercury at C until the surface is at the same level D and E in the two tubes

Screw in the cap at A tightly so that a quantity of air is enclosed at atmospheric pressure

Pour in more mercury at C until the level of the mercury in the longer arm stands at G . The level of the mercury in the shorter arm will be found to have risen to

some such point as F , which however is below G . It follows that the air in the shorter arm has been diminished in volume

Let h be the height of the mercury barometer at the time, and let H be the point on the longer tube at the same level as F . Then the pressure of the enclosed air

= pressure at F

= pressure at H

= wt of column HG + pressure at G

= wt of column HG + wt of column h

= wt of a column $(HG + h)$

$$\frac{\text{final pressure}}{\text{original pressure}} = \frac{\text{wt of a column } (HG + h)}{\text{wt of a column } h} = \frac{HG + h}{h}.$$

Also $\frac{\text{original volume of the air}}{\text{final volume of the air}} = \frac{DA}{FA}$

It is found, when careful measurements are made, that

$$\frac{HG + h}{h} = \frac{DA}{FA}$$

$$\therefore \frac{\text{final pressure}}{\text{original pressure}} = \frac{\text{original volume}}{\text{final volume}},$$

i.e. final pressure . original pressure

$$\frac{1}{\text{final volume}} = \frac{1}{\text{original volume}}$$

This proves the law for a diminution in the volume of the air

105. Boyle's Law for an expansion of air may be verified in the following manner

Take a vessel containing mercury and a tube AC partially filled with mercury and open at the end C .

Insert the tube and hold it in a vertical position with its unclosed end C under the surface of the mercury in the vessel. Hold it initially so that the level of the mercury inside and outside the tube is the same. Let the point of the tube which is now at the surface of the mercury be B , so that the enclosed air when at atmospheric pressure occupies a length AB .

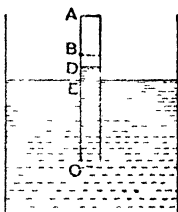

Raise the tube some distance out of the mercury. The air will be found to expand and also the mercury to rise inside the tube. Let the common surface of the mercury and enclosed air be now at D .

If h be the height of the mercury barometer at the time of the experiment, the original pressure of the air inside the tube was $g\rho h$. After the tube has been lifted the pressure of the air inside is the same as that of the mercury at D , and = pressure at $E - g\rho$. $DE = g\rho(h - DE)$

Also the original and final volumes are proportional to AB and AD .

It is found, on careful measurements being made, that

$$\frac{h - DE}{h} = \frac{AB}{AD},$$

i. e. that $\frac{\text{final pressure}}{\text{original pressure}} = \frac{\text{original volume}}{\text{final volume}}$.

106. Boyle's Law may also be verified by the following method, which is a modification of that of Art 104, and is applicable to both increases and decreases of the volume of the air

AB and CD are two glass tubes which are connected by flexible rubber tubing and are attached to a vertical stand AB is closed at the top but CD is open. A vertical scale is fixed to the stand, and CD can move in a vertical direction parallel to this scale. The rubber tubing and the lower part of the glass tubes are filled with mercury. The upper part of the tube AB is filled with air, and its pressure at any time is measured by $h + ED$, where E is at the same level as B and h is the height of the mercury barometer. Raise or lower the movable tube CD . Then in all cases it will be found that

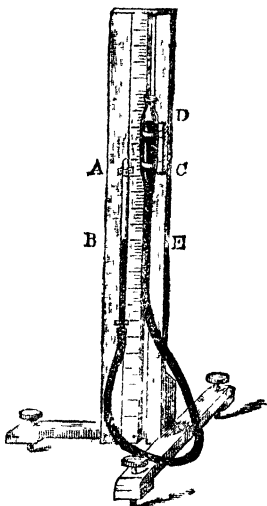

$$AB \propto \frac{1}{h + ED},$$

$$\text{i.e. that volume} \propto \frac{1}{\text{pressure}}.$$

107. Until comparatively recent times it was supposed that Boyle's Law was perfectly accurate. More careful experiments have shown that it is not strictly accurate for all gases. It is however extremely near the truth for gases which are very hard to liquefy, such as air, oxygen, hydrogen, and nitrogen. Most gases are rather more compressible than Boyle's Law would imply.

It is found that for all gases, except hydrogen, the product of the volume and pressure diminishes, for moderate pressures, as the pressure increases, and that this diminution is greater the more easily the gas is liquefied, on the other hand, for hydrogen the product of the volume and pressure slightly increases as the pressure increases

A gas which accurately obeyed Boyle's Law would be called a **Perfect Gas** The above-mentioned gases are nearly perfect gases

108 Let p' be the original pressure, v' the original volume, and ρ' the original density of a given mass of gas

When the volume of this gas has been altered, the temperature remaining constant, let p be the new pressure, v the new volume, and ρ the new density of the gas.

Boyle's Law states that

$$\frac{p}{p'} = \frac{v'}{v},$$

$$p \cdot v = p' \cdot v' \quad \dots \dots \dots (1)$$

Now $\rho \cdot v$ and $\rho' \cdot v'$ are each equal to the given mass of the gas which cannot be altered

$$\rho \cdot v = \rho' \cdot v' \dots \dots \dots (2)$$

From (1) and (2), by division,

$$\frac{p}{\rho} = \frac{p'}{\rho'}$$

Hence $\frac{p}{\rho}$ is always the same for a given gas Let its value be denoted by k , so that $p = k\rho$

Ex Assuming the sp gr of air to be 0013 when the height of the mercury barometer is 30 inches, the sp gr of mercury to be 13 596, and the value of g to be 32 2, prove that the value of k , for foot-second units, is 841906 nearly

Find also the value for c.g.s units, assuming $g=981$ and that the height of the mercury barometer is 76 cms

$$p = \frac{30}{12} \times 13\,596 \times g \times 62\frac{1}{2} \text{ poundals per square foot,}$$

and

$$\begin{aligned} \rho &= 0013 \times 62\frac{1}{2} \text{ lbs} \\ \therefore k &= \frac{30}{12} \times 13\,596 \times 32.2 \times \frac{1}{0013} \\ &= \frac{10941780}{13} = 841906 \text{ nearly.} \end{aligned}$$

In c g s measure,

$$p = 76 \times 13\,596 \times 981 \text{ dynes per sq cm.,}$$

and

$$\begin{aligned} \rho &= 0013 \text{ grammes per cub cm} \\ \therefore k &= \frac{76 \times 13\,596 \times 981}{0013} = \frac{76 \times 135960 \times 981}{13} \\ &= 779741000 \text{ nearly} \end{aligned}$$

109 Ex 1 *The sp gr of mercury is 13.6 and the barometer stands at 30 ins. A bubble of gas, the volume of which is 1 cub in when it is at the bottom of a lake 170 ft deep, rises to the surface. What will be its volume when it reaches the surface?*

If w be the weight of a cub ft of the water, the pressure per sq ft at the bottom of the lake

$$\begin{aligned} &= 170w + 13.6 \times 2\frac{1}{2}w \\ &= 204w \end{aligned}$$

Also the pressure at the top of the lake = $13.6 \times 2\frac{1}{2}w$

$$= 34w$$

Hence, if x be the required volume, we have

$$x \times 34w = 1 \times 204w.$$

$$x = 6 \text{ cub ins.}$$

Ex 2 *At what depth in water would a bubble of air sink, given that the weights of a cub ft of water and air are respectively 1000 and $1\frac{1}{4}$ ozs, and that the height of the water barometer is 34 ft?*

Let x be the depth at which the bubble would just float. This is the case when the density of air at this depth is just equal to the density of water.

Then, by Boyle's Law,

$$\begin{aligned} \frac{x+34}{34} &= \frac{\text{density of air at depth } x}{\text{atmospheric density}} \\ &= \frac{\text{density of water}}{\text{atmospheric density}}, \text{ since the bubble just floats,} \\ &= \frac{1000}{1\frac{1}{4}} = 800. \end{aligned}$$

$\therefore x = 27166 \text{ ft} = \text{slightly greater than 5 miles}$

Below this depth the bubble would sink, above this depth it would
1186

110 Cartesian Diver This toy consists of a hollow glass bulb at the bottom of which is a small opening, to this bulb is attached at its lower end a counterpoise—usually the figure of a man. There is some air in the bulb, and the amount of this air and the weight of the toy are so adjusted that the whole would just float in water

It floats in the water contained in a cylinder, the upper end of which is closed by a piece of bladder or india-rubber. If the hand be pressed on this bladder, the air underneath is compressed, and thus by Boyle's Law its pressure increased. This additional pressure is conveyed through the water to the air inside the toy and the volume of this air is thus decreased, by Boyle's Law

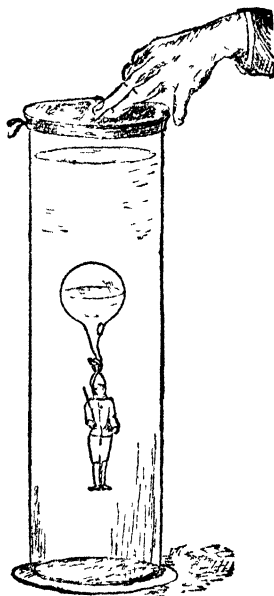

The Diver now displaces less water than before, and thus the upward vertical thrust of the water is decreased. Hence, since its weight remains unaltered, it sinks.

On removing the hand the pressure is lessened, and the diver in general rises again.

If the vessel be deep enough it may however happen that, even when the external air pressure is removed, the air inside the bulb, when it is at the bottom of the vessel, may occupy so little space that the weight of the diver exceeds the weight of the displaced water. In this case the toy will not rise again.

EXAMPLES. XXII

1. What is the sp gr of the air at standard pressure (760 mm of mercury) when the sp gr of air at a pressure of 700 mm. of mercury, referred to water at 4° C. as standard, is found to be 00119?

2. When the height of the mercurial barometer changes from 29.45 ins. to 30.23 ins., what is the change in the weight of 1000 cub ins of air, assuming that 100 cub ins of air weigh 31 grains at the former pressure?

3. When the water barometer is standing at 33 ft a bubble at a depth of 10 ft from the surface of water has a volume of 3 cub. ins. At what depth will its volume be 2 cub. ins.?

4. Assuming the height of the water barometer to be h , find to what depth an inverted tumbler must be submerged so that the volume of the air inside may be reduced to one-third of its original volume.

Find also to what depth a small inverted conical wine glass must be lowered so that the water may rise half way up it.

5. A cylindrical test tube is held in a vertical position and immersed mouth downward in water. When the middle of the tube is at a depth of 32.75 ft. it is found that the water has risen half way up the tube. Find the height of the water barometer.

6. A uniform tube closed at the top and open at the bottom is plunged into mercury, so that 25 cms of its length is occupied by gas at an atmospheric pressure of 76 cms of mercury, the tube is now raised till the gas occupies 50 cms., by how much has it been raised?

7. What are the uses of the small hole which is made in the lid of a teapot and of the vent peg of a beer barrel?

8. A hollow closed cylinder, of length 2 ft, is full of air at the atmospheric pressure of 15 lbs per square inch when a piston is 12 ins from the base of the cylinder, more air is forced in through a hole in the base of the cylinder till there is altogether three times as much air in the cylinder as at first, if the piston be now allowed to rise 4 ins, what is the pressure of the air on each side of the piston?

Through how many inches must the piston move from its original position to be again in equilibrium?

9. A balloon half filled with coal-gas just floats in the air when the mercury barometer stands at 30 ins. What will happen if the barometer sinks to 28 ins?

What would happen if the balloon had been quite full of gas at the higher pressure?

10. A gas-holder consists of a cylindrical vessel inverted over water. Its diameter is $2\frac{1}{2}$ ft and its weight 60 lbs. Find what part of the weight of the cylinder must be counterpoised to make it supply gas at a pressure equivalent to that of 1 in. of water.

11. A pint bottle containing atmospheric air just floats in water when it is weighted with 5 ozs. The weight is then removed and the bottle immersed neck downwards and gently pressed down.

Shew that it will just float freely when the level of the water inside the bottle is 11 ft below the surface, and will sink if lowered further, and rise if raised higher. The water barometer stands at 33 ft and a pint of water weighs 20 ozs.

12. A closed air-tight cylinder, of height $2a$, is half full of water and half full of air at atmospheric pressure, which is equal to that of a column, of height h , of the water. Water is introduced without letting the air escape so as to fill an additional height k of the cylinder, and the pressure of the base is thereby doubled. Prove that

$$k = a + h - \sqrt{ah + h^2}$$

13. In a vertical cylinder, the horizontal section of which is a square of side 1 ft, is fitted a weightless piston. Initially the air below the piston occupies a space 7 ft in length and is at the same pressure as the external air. 6 cub ft of water are taken and two-thirds of a cub ft of iron. If the iron be placed on the piston it sinks 1 ft. If the water also be then poured on it, it sinks through $\frac{36}{41}$ ft. Find the sp gr of iron and the height of the water barometer.

14. A hollow cylinder, of height h and open at the top, is inverted and partially immersed so that a length k of it is under water, prove that the air inside it occupies a length x given by the equation

$$x^2 + x(H + k - h) = Hh,$$

where H is the height of the water barometer

15. An open canister, $4\frac{7}{32}$ ins high, is inverted over a vessel of mercury and pressed down until its bottom is in the surface of the fluid. Find how high the mercury will have risen within the canister, the height of the mercury barometer being 30 ins

16. A conical wine-glass, 4 ins in height, is lowered, mouth downwards, into water till the level of the water inside is 34 ft below the surface, the height of the water barometer being 34 ft, what is the height of the part of the cone now occupied by air?

17. A thin conical surface of weight W just sinks to the surface of a liquid when immersed with its open end downwards, when immersed with its vertex downwards a weight mW must be placed inside it to make it sink to the same depth as before, if h be the height of a barometer of the same liquid, prove that the height of the cone is $hm\sqrt{1+m}$

18. A circular cylinder closed at one end has a height of 8 ft and the area of the external cross section is to that of the internal cross section as 7 : 4, the thickness of the flat end may be neglected and the sp gr of the cylinder is 2

This vessel is pushed into water with the mouth downwards, prove that if the depth of the mouth exceed 13 ft, the cylinder will of itself sink lower, the height of the water barometer being 33 ft

19. A cylinder, of height 5 ft with its axis vertical, is full of air at atmospheric pressure, and is closed at the top by a tightly fitting piston of mass 30 lbs, if the piston sinks 2 ft under its own weight, find the thrust that must be applied to the piston to force it down an additional 2 ft

20. A piston of weight 62.5π lbs fits accurately in a cylinder, whose axis is vertical, and encloses a volume of air which is 1 ft in height when 3 ft of water stands in the cylinder above the piston. A sphere of density 6.6 and diameter 9 ins is now suspended by a string freely, and is completely immersed in the water, if the diameter of the cylinder be 1 ft, find the depth through which the piston will sink

21. A piston, of weight W , is placed at the middle of a horizontal cylinder which it closely fits, the air on each side of it being of atmospheric pressure H , and the ends of the cylinder closed. The

cylinder is then tilted up till its axis is inclined at angle α to the horizon, prove that the piston will be in equilibrium again at a distance from its original position equal to

$$a [\sqrt{1 + \lambda^2 \operatorname{cosec}^2 \alpha} - \lambda \operatorname{cosec} \alpha],$$

where $2a$ is the length of the cylinder, A is the area of the piston, and

$$\lambda = \frac{H}{A} \frac{A}{W}$$

22. A weightless piston fits into a vertical cylinder, of height h , closed at its base and filled with air, and is initially at the top of the cylinder, water is slowly poured into the cylinder upon the top of the piston, prove that a quantity which would fill a length $h - H$ of the cylinder can be poured in before any runs over, where H is the height of the water barometer

Explain the case where $H > h$

111 *Relations between the pressure, temperature, and density of a gas*

It can be shewn experimentally that a given mass of gas, for each increase of 1°C in its temperature, has its volume increased (provided its pressure remain constant) by an amount which is equal to 003665 times ($= \frac{1}{273}$ nearly) its volume at 0°C

Thus, if V_0 be the volume of the given mass of gas at temperature 0°C and α stand for 003665, the increase in volume for each degree Centigrade of temperature is αV_0 . Hence the increase for $t^\circ \text{C}$ is $\alpha V_0 t$, so that if V be the volume of this air at temperature $t^\circ \text{C}$, then

$$V = V_0 + \alpha V_0 t = V_0 (1 + \alpha t)$$

If ρ and ρ_0 be the respective densities at the temperatures $t^\circ \text{C}$ and 0°C ., then, since

$$\rho V = \rho_0 V_0,$$

we have

$$\frac{\rho_0}{\rho} = \frac{V}{V_0} = 1 + \alpha t.$$

$$\therefore \rho_0 = \rho (1 + \alpha t).$$

The above law is sometimes known as Gay-Lussac's and sometimes as Charles'.

112. A relation similar to that of the previous article holds for all gases. For those approximating to perfect gases a is very nearly the same quantity.

If the temperature be measured by the Fahrenheit thermometer and not the Centigrade, the value of a is $\frac{5}{9} \times \frac{1}{273}$ nearly [for 180 degrees on the Fahrenheit scale equal 100 degrees on the Centigrade scale, i.e. $1^\circ \text{F} = \frac{5}{9}^\circ \text{C}$]

Ex 1 *If the volume of a certain quantity of air at a temperature of 10°C be 300 cub cms, what will be its volume (at the same pressure) when its temperature is 20°C ?*

If V be its volume at 0°C , then

$$300 = V + 10 \frac{1}{273} V = \frac{283}{273} V.$$

$$\therefore V = \frac{273}{283} \times 300.$$

Hence the volume at $20^\circ \text{C} = V + 20 \frac{1}{273} V$

$$= \frac{293}{273} V = \frac{293}{283} \times 300 = 310 \frac{170}{283} \text{ cub cms.}$$

Ex 2 *The volume of a certain quantity of gas at 15°C is 400 cub cms, if the pressure be unaltered, at what temperature will its volume be 500 cub cms?*

Let t be the required temperature. Then

$$\begin{aligned} \frac{500}{400} &= \frac{\text{volume at temp } t^\circ \text{C}}{\text{volume at temp } 15^\circ \text{C}} = \frac{1 + \frac{t}{273}}{1 + \frac{15}{273}} \\ &= \frac{273 + t}{288} \end{aligned}$$

$$\therefore t = 87^\circ \text{C.}$$

113. Suppose the gas at a temperature 0°C to be confined in a cylinder, and to support a piston of such a weight that the pressure of the gas is p , and let the density of the gas be ρ_0 , so that

$$p = k\rho_0 \dots \dots \dots (1)$$

Let heat be applied to the cylinder till the temperature of the gas is raised to $t^{\circ}\text{C}$., and let the density then be ρ

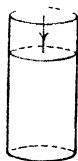

By Charles' law we have then

$$\rho_0 = \rho (1 + at) \dots\dots\dots (2)$$

From (1) and (2), we have

$$p = k\rho (1 + at),$$

giving the relation between the pressure, density, and temperature of the gas

114 Absolute temperature If a gas were continually cooled till its temperature was far below 0°C ., and if it did not liquify and continued to obey Charles' and Boyle's Laws, its pressure would be zero at a temperature t_1 , such that

$$1 + at_1 = 0,$$

i e when
$$t_1 = -\frac{1}{a} = -273.$$

This temperature -273° is called the absolute zero of the Air Thermometer, and the temperature of the gas measured from this zero is called the absolute temperature. The absolute temperature is generally denoted by T , so that

$$T = \frac{1}{a} + t.$$

Hence

$$p = k\rho(1 + at) = k\rho a \left(\frac{1}{a} + t \right) = k\rho a T$$

Therefore, if V be the volume of a certain quantity of gas, we have

$$\frac{p}{T} \frac{V}{\rho} = k a [V \rho] = k a \times \text{mass of the gas} = \text{a constant}$$

Hence the product of the pressure and volume of any given mass of gas is proportional to its absolute temperature

Ex The radius of a sphere containing air is doubled, and the temperature raised from 0°C to 91°C . Prove that the pressure of the air is reduced to one-sixth of its original value, the coefficient of expansion per 1°C . being $\frac{1}{273}$.

Let p be the original and p' the final pressure, ρ the original and ρ' the final density

Since the radius of the sphere is doubled, the final volume is 8 times the original volume

$$\begin{aligned} \rho' &= \frac{1}{8}\rho \\ \therefore \frac{p'}{p} &= \frac{k\rho'(1 + a \cdot 91)}{k\rho} = \frac{1}{8} \left[1 + \frac{91}{273} \right] \\ &= \frac{1}{8} \frac{364}{273} = \frac{1}{6}. \end{aligned}$$

EXAMPLES XXIII

[In the following examples take a as $\frac{1}{273}$]

- 1 Find the volumes at 0°C and pressure 76 cms of mercury of
 - (1) the air whose volume at pressure 80 cms and temp 30°C is 100 cub cms
 - (2) the air whose volume at 3 atmospheres and temp 100°F is 3 cub. ft

2. If a quantity of gas under a pressure of 57 ins of mercury and at a temperature of 69°C occupy a volume of 9 cub ins, what volume will it occupy under a pressure of 51 ins of mercury and at a temperature of 16°C ?

3. A mass of air at a temperature of 39°C and a pressure of 32 ins of mercury occupies a volume of 15 cub ins. What volume will it occupy at a temperature of 78°C . under a pressure of 54 ins of mercury?

4. At the sea-level the barometer stands at 750 mm and the temperature is 7°C , while on the top of a mountain it stands at 400 mm and the temperature is 13°C , compare the weights of a cub metre of air at the two places

5. A cylinder contains two gases which are separated from each other by a movable piston. The gases are both at 0°C and the volume of one gas is double that of the other. If the temperature of the first be raised t° , prove that the piston will move through a space $\frac{2lat}{9+6at}$, where l is the length of the cylinder, and a is the coefficient of expansion per 1°C

6. The radius of a sphere containing air is doubled and the temperature raised from 0°C to 455°C . Shew that the pressure of the air is reduced to one third of its original value, the coefficient of expansion of air per 1°C being $\frac{1}{273}$

7. Find the value of $\frac{pI}{T}$ for a gramme of air supposing a centimetre cube of air at 80°C to be 001 gramme when the height of the barometer is 76 cms, the density of mercury 13 596, and the numerical value of the acceleration of gravity 981, the expansion of air at a constant pressure from freezing to boiling point being from 1 to 1 366

8. A piston accurately fits a cylinder and moves freely in it, initially it is placed in the middle of the cylinder and the ends are closed. The cylinder being placed vertically the distance of the piston from the top is $\sqrt{2}$ times its original distance. The temperature in the two parts being raised to the absolute temperatures t_1 and t_2 , the piston goes back to the middle of the cylinder. Shew that the original absolute temperature of the cylinder was $t_1 \sim t_2$

115. Pressures of a mixture of gases. It can be shewn experimentally that if two gases occupy two vessels and be of the same temperature and pressure, and if they be mixed together, the pressure of the mixture is the same as before, provided that no chemical action takes place between the gases.

116 *If the pressures of two gases of the same temperature and volume v be p_1 and p_2 , the pressure of the mixture of the two gases, when the combined volume is v , is $p_1 + p_2$, the temperature being unaltered*

Change the volume of the second gas so that its pressure is p_1 . Its volume, by Boyle's Law, is then $\frac{vp_2}{p_1}$

We thus have two volumes, v and $\frac{vp_2}{p_1}$, of different gases each at pressure p_1

Let them be mixed together

By the experimental fact of the previous article they form a mixture of volume $v + v\frac{p_2}{p_1}$ at pressure p_1

Let the volume of the mixture be now changed to v and let the corresponding pressure be P . Then, by Boyle's Law, we have

$$v P = \left(v + v\frac{p_2}{p_1} \right) \times p_1,$$

$$P = p_1 + p_2$$

117. *Two volumes, v_1 and v_2 , of different gases at different pressures, p_1 and p_2 , are mixed together and put into a vessel of volume V , find the resulting pressure, the temperatures being constant*

Change the pressure of the second gas from p_2 to p_1 , by Boyle's Law its volume changes from v_2 to $\frac{v_2 p_2}{p_1}$

We thus have two gases, of volumes v_1 and $\frac{v_2 p_2}{p_1}$, each of pressure p_1

As before they form a mixture, of volume $v_1 + \frac{v_2 p_2}{p_1}$, of pressure p_1 .

Let the volume of this mixture be changed to V and in consequence the pressure to P . Then, by Boyle's Law,

$$P \cdot V = p_1 \times \left(v_1 + \frac{v_2 p_2}{p_1} \right) = p_1 v_1 + p_2 v_2,$$

∴ e the required pressure

$$= \frac{p_1 v_1 + p_2 v_2}{V}$$

118 If, as in Art 116, we had several gases, each of volume v , and of pressures $p_1, p_2, p_3,$ we should similarly have that the pressure of the mixture, when of volume v , is $p_1 + p_2 + p_3 +$

This is known as Dalton's Law for the mixture of gases and may be put thus, If several gases are included in a given volume, the pressure of each is the same as if the others were absent, so that the pressure of the mixture is the sum of the pressures exerted by the separate gases.

Ex Masses m, m' of two gases in which the ratios of the pressure to the density are respectively k and k' are mixed at the same temperature. Shew that the ratio of the pressure to the density in the mixture is

$$\frac{mk + m'k'}{m + m'}$$

*** 119 Determination of heights by means of the barometer** *If the atmosphere be at rest and its temperature constant, then, if points be taken whose heights above the earth are in Arithmetical Progression, (the common difference being small,) the pressures at these points are in G P*

Let $P_1, P_2, P_3,$ be a series of points in a vertical line, and let

$$OP_1 - P_1P_2 = P_2P_3 = \dots = P_{n-1}P_n \\ = \beta, \text{ where } \beta \text{ is small}$$

Consider a column of air, of small horizontal section, whose axis is the straight line OP_1P_2

* The student who is acquainted with the Integral Calculus may

The distance β being small, we may consider any layers of this column to be of constant density throughout, let the densities of the layers commencing from the bottom be ρ_1, ρ_2, \dots , and therefore their pressures $k\rho_1, k\rho_2, \dots$, which we may take to be the pressures at the points O, P_1, P_2, \dots .

The difference of the pressures on the faces at O and P_1 supports the element OP_1 . Hence

$$k\rho_1 - k\rho_2 = g\rho_1\beta$$

So for the columns $P_1P_2, P_2P_3, P_3P_4, \dots$ we have

$$k\rho_2 - k\rho_3 = g\rho_2\beta,$$

$$k\rho_3 - k\rho_4 = g\rho_3\beta,$$

.

$$k\rho_{n-1} - k\rho_n = g\rho_{n-1}\beta$$

Hence $\rho_2 = \rho_1 \left[1 - \frac{g\beta}{k} \right],$

$$\rho_3 = \rho_2 \left[1 - \frac{g\beta}{k} \right] = \rho_1 \left[1 - \frac{g\beta}{k} \right]^2,$$

$$\rho_4 = \rho_3 \left[1 - \frac{g\beta}{k} \right] = \rho_1 \left[1 - \frac{g\beta}{k} \right]^3,$$

...

$$\rho_n = \rho_{n-1} \left[1 - \frac{g\beta}{k} \right] = \rho_1 \left[1 - \frac{g\beta}{k} \right]^{n-1}.$$

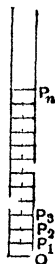

Hence the densities $\rho_1, \rho_2, \rho_3, \dots$, and therefore the corresponding pressures, are in G.P.

If ρ be the density just above P_n , we have similarly

$$\rho = \rho_n \left[1 - \frac{g\beta}{k} \right] = \rho_1 \left[1 - \frac{g\beta}{k} \right]^n.$$

If we put $n\beta = h$, so that ρ is the density at a height above the ground, we have

$$\rho = \rho_1 \left[1 - \frac{gh}{nk} \right]^n.$$

Let
$$\frac{gh}{nk} = \frac{1}{z},$$

then
$$\rho = \rho_1 \left[1 - \frac{1}{z} \right]^{kz} = \rho_1 \left\{ \left[1 - \frac{1}{z} \right]^z \right\}^{kz}.$$

Now let n be increased indefinitely, h being kept constant, let the number of layers into which OP_n is divided be made infinite

Then it is known that

$$\text{Lt}_{z \rightarrow \infty} \left[1 - \frac{1}{z} \right]^z = e,$$

where e is the base of the Napierian system of logarithms

$$\rho = \rho_1 e^{-\frac{gh}{k}}$$

This formula gives the density at a height h in terms of that at the surface of the earth. It has been obtained on the assumption that g is constant, this is only true for a comparatively short distance from the earth's surface. The temperature is also supposed to be constant which will not be the case for any considerable difference in altitude.

120 *To find the difference in the altitude of two points by means of barometric readings*

The formula of the preceding article gives

$$\rho = \rho_1 e^{-\frac{gh}{k}}$$

Let H and H_1 be the readings of a barometer at the two places, then

$$H \cdot H_1 = \rho \cdot \rho_1, \text{ by Boyle's Law.}$$

$$\therefore \frac{H}{H_1} = e^{-\frac{gh}{k}}.$$

$$\begin{aligned} \therefore \log_e \frac{H}{H_1} &= \frac{-gh}{k} \\ \therefore h &= \frac{k}{g} \log_e \frac{H_1}{H} = \frac{k}{g} \log_{10} \frac{H_1}{H} \times \log_e 10 \\ &= \frac{k \log_e 10}{g} [\log_{10} H_1 - \log_{10} H] \end{aligned}$$

Hence the height in feet is obtained by multiplying the difference between the logarithms of the two barometric heights by $\frac{k}{g} \log_e 10$

Taking the value of k as found in Art 108, Ex, $g = 32.2$ and $\log_e 10 = \frac{1}{\log_{10} e} = \frac{1}{43429} = 2.3026$,

the value of this constant, when feet are used, is about 60200

When c g s units are used, we have found the value of k to be about 779741000 [Art 108]

Thus, since $g = 981$ in this system, the constant

$$\begin{aligned} &= \frac{779741000 \times 2.3026}{981} \\ &= 1830300 \text{ nearly} \end{aligned}$$

Ex 1 Shew that a fall in the barometer from 76 to 75 cms will correspond to a rise of about 105 metres, given

$$\log_{10} e = 43429, \quad \log_{10} 76 = 1.88081 \quad \text{and} \quad \log_{10} 75 = 1.87506$$

Ex 2 If a change from 30 inches to 25 inches in the height of the barometer corresponds to an altitude of 4500 feet, shew that the altitude corresponding to the height 20 inches of the barometer is about 10007 feet

121. We now give some examples dealing with defective barometers.

Ex 1 10 cub. cms of air at atmospheric pressure are measured off. When introduced into the vacuum of a barometer they depress the mercury, which originally stood at 76 cms, and occupy a volume of 15 cub cms. What is the final height of the barometer?

Let Π denote the atmospheric pressure. By Boyle's Law we have

$$\frac{\text{final pressure of the air}}{\Pi} = \frac{\text{original volume}}{\text{final volume}} = \frac{10}{15} = \frac{2}{3}.$$

$$\text{final pressure of the air} = \frac{2}{3}\Pi$$

The pressure above the column of mercury is now $\frac{2}{3}$ of atmospheric pressure, so that the length of the column of mercury is only $\frac{1}{3}$ of its original length and is therefore $25\frac{1}{3}$ cm.

Ex 2 When the reading of the true barometer is 30 ins the reading of a barometer, the tube of which contains a small quantity of air whose length is then $3\frac{1}{3}$ ins, is 28 ins. If the reading of the true barometer fall to 29 ins, prove that the reading of the faulty barometer will be $27\frac{1}{3}$ ins.

At an atmospheric pressure of 30 ins of mercury, let x ins be the length of the column of air. When the length is $3\frac{1}{3}$ ins, its pressure per square inch

$$= \frac{x}{3\frac{1}{3}} \times \text{atmospheric pressure} = \frac{x}{3\frac{1}{3}} w \quad w \quad 30,$$

where w is the weight of a cubic inch of mercury.

Hence, for the equilibrium of the faulty barometer, we have

$$\begin{aligned} \frac{x}{3\frac{1}{3}} w \quad 30 + w \quad 28 &= \text{atmospheric pressure} \\ &= w \quad 30 \\ x &= \frac{20}{3} \end{aligned}$$

When the real barometer pressure is 29 ins, let the height of the faulty barometer be y ins, so that the pressure of the air per sq. inch

$$\begin{aligned} &= \frac{x \times 30}{31\frac{1}{3} - y} w \\ \therefore 29 &= y + \frac{x}{31\frac{1}{3} - y} \times 30 = y + \frac{20}{94 - 3y}. \\ y &= 27\frac{1}{3}, \end{aligned}$$

the other solution of this equation, viz. 33, being clearly inadmissible.

Ex 3 The readings of a faulty barometer in which there is some air are a and b when the true readings are α and β , find the true reading when the faulty barometer reads c .

Let the quantity of air be such that it would occupy a length x of the barometer at an atmospheric pressure equal to h inches of mercury

In the first case the pressure of air is that due to $\alpha - a$ inches, and thus its length then $= \frac{h}{\alpha - a} x$, by Boyle's Law.

Thus the whole length of the barometer tube is $a + \frac{hx}{\alpha - a}$

Thus, in the second case, the air is of length $a + \frac{hx}{\alpha - a} - b$, and its pressure is $\beta - b$

Hence, by Boyle's Law, $(\beta - b) \left(a + \frac{hx}{\alpha - a} - b \right) = hx$.

$$hx = \frac{(\alpha - a)(\beta - b)(a - b)}{(\alpha - a) - (\beta - b)}$$

In the third case, if γ be the true height, the length of the air is $a + \frac{hx}{\alpha - a} - c$, and its pressure $\gamma - c$.

$$\left(a + \frac{hx}{\alpha - a} - c \right) (\gamma - c) = hx$$

$$\therefore \gamma = c + \frac{hx}{a - c + \frac{hx}{\alpha - a}}$$

$$= c + \frac{(\alpha - a)(\beta - b)(a - b)}{(a - c)(\alpha - a) - (b - c)(\beta - b)},$$

after reduction.

EXAMPLES. XXIV.

1. Why does a small quantity of air introduced into the upper part of a barometer tube depress the mercury considerably, whilst a small portion of iron floating on the mercury hardly depresses it at all?

2. A barometer stands at 30 ins. The vacuum above the mercury is perfect, and the area of the cross-section of the tube is a quarter of a sq in. If a quarter of a cub in of the external air be allowed to get into the barometer, and the mercury then fall 4 ins, what was the volume of the original vacuum?

3 A bubble of air having a volume of 1 cub in at a pressure of 30 ins of mercury escapes up a barometer tube, whose cross-section is 1 sq. in and whose vacuum is 1 in. long. How much will the mercury descend?

4. The top of a uniform barometer tube is 33 ins above the mercury in the tank, but on account of air in the tube the barometer registers 28 6 ins when the atmospheric pressure is equivalent to that of 29 in of mercury. What will be the true height of the barometer when the height registered is 29 48 ins?

5. The top of a uniform barometer tube is 36 ins above the surface of the mercury in the tank. In consequence of the pressure of air above the mercury the barometer reads 27 ins when it should read 28 5 ins. What will be the true height when the reading of the barometer is 30 ins?

6 The readings of a true barometer and of a barometer which contains a small quantity of air in the upper portion of the tube are respectively 30 and 28 ins. When both barometers are placed under the receiver of an air pump from which the air is partially exhausted, the readings are observed to be 15 and 14 6 ins respectively.

Prove that the length of the tube of the faulty barometer measured from the surface of the mercury in the basin is 31 35 ins.

7. The two limbs of a Mariotte's tube are graduated in inches. The mercury in the shorter tube stands at the graduation 4, and 5 ins of air are enclosed above it. The mercury in the other limb stands at the graduation 38, and the barometer at the time indicates a pressure of 29 5 ins. Find to what pressure the 5 ins of air are subjected and also the length of the tube they would occupy under barometric pressure alone.

8. A U tube of uniform bore, closed at one end and with vertical arms, contains mercury at the same level in both arms. If mercury sufficient to fill 8 inches of the tube be poured in, the level of the mercury in the closed arm is raised one inch, and, if a further quantity sufficient to fill 11 inches be added, the level is raised another inch. Find the height of the mercury barometer.

9. The space above the mercury in a barometer contains some air, and the barometer reads 700 mm when a standard barometer reads 762 mm. Find in grammes weight per sq. cm the pressure of the enclosed air. [Sp gr of mercury = 13 596.]

10 If a barometer consisting of a uniform bent tube have an imperfect vacuum, and if the apparent reading be 31 inches when the true reading is 32 inches, and the length of the vacuum then be one inch, find the true reading when the apparent reading is 29½ inches, the temperature being unaltered.

11 When the true barometric height is 30 inches, the mercury stands at 29.8 in a barometer with a defective vacuum. What fraction of the space above the mercury would the air fill if it were compressed to atmospheric pressure?

12. A barometer stands at 30 inches, and the space occupied by the Torricellian vacuum is then 2 inches, if now a bubble of air which would at atmospheric pressure occupy half an inch of the tube be introduced into it, shew that the surface of the mercury in the tube will be lowered 3 inches. Shew also that the height of a correct barometer, when the incorrect one stands at x inches, is

$$x + \frac{15}{32 - x} \text{ inches}$$

13. A barometer with an imperfect vacuum stands at 29.8 and 29.4 inches when a correct barometer indicated 30.4 and 29.8 inches respectively, when the faulty barometer stands at 29, shew that the true atmospheric pressure is 29.3 inches.

14 The height of the Torricellian vacuum in a barometer is a inches, and the instrument indicates a pressure of b inches of mercury when the true reading is c inches. If the faulty readings are due to an imperfect vacuum, prove that the true reading corresponding to an apparent reading of d inches is $d + \frac{a(c-b)}{a+b-d}$.

CHAPTER VIII.

MACHINES AND INSTRUMENTS ILLUSTRATING THE
PROPERTIES OF FLUIDS

122 Diving Bell This machine consists of a heavy hollow cylindrical, or bell-shaped, vessel constructed of metal and open at its lower end. It is heavy enough to sink under its own weight, carrying down with it the air which it contains. Its use is to enable divers to go to the bottom of deep water and to perform there what operations

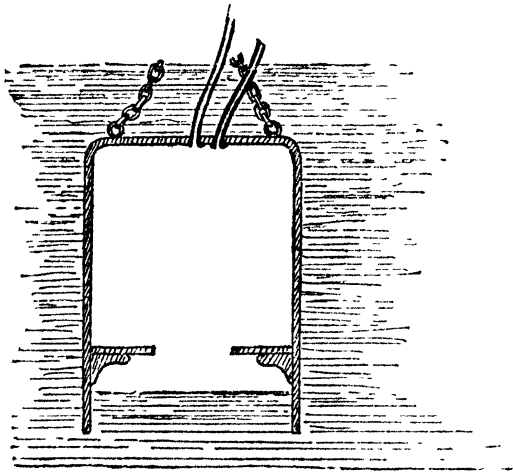

they wish. The bell is lowered into the water by means of a chain attached to its upper end.

As the bell sinks into the water the pressure of the contained air, which is always equal to that of the water with which it is in contact, gradually increases. The volume of the contained air, by Boyle's Law, therefore gradually diminishes and the water will rise within the bell.

To overcome this compression of the air, a tube communicates from the upper surface of the bell to the surface of the water, and by this tube pure air is forced down into the bell, so that the surface of the water inside it is always kept at any desired level. A second tube leads from the bell to the surface of the water so that the vitiated air may be removed.

The tension of the chain which supports the bell is equal to the weight of the bell less the weight of the quantity of water that it displaces. If no additional air be pumped in as the bell descends, the air becomes more and more compressed, and therefore the amount of water displaced continually diminishes. Hence, in this case, the tension of the chain becomes greater and greater.

123 *A diving bell is lowered into water of given density. If no air be supplied from above, find*

- (1) *the compression of the air at a given depth a ,*
- (2) *the tension of the chain at this depth, and*
- (3) *the amount of air at atmospheric pressure that must be forced in so that at this depth the water may not rise within the bell.*

(1) Let b be the height of the bell. At a depth a , let x be the length of the bell occupied by the air, and let h be the height of the water barometer in atmospheric air.

Let Π be the pressure of the atmosphere Π' the pressure of the air inside the bell, and w the weight of a unit volume of water,

so that $\Pi = wh,$

and $\Pi \cdot b = \Pi' x$, by Boyle's Law.

Hence $\Pi' = w \frac{hb}{x}.$

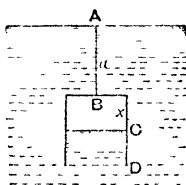

Now the pressure of the air and the water at their common surface inside the bell must be equal for equilibrium

$$\begin{aligned} \therefore \Pi' &= \text{pressure at } C = w(x + a) + \Pi \\ &= w(x + a + h) \end{aligned}$$

Equating these two values of Π' , we have

$$w \frac{hb}{x} = w(x + a + h),$$

so that $x^2 + (a + h)x - hb = 0$

This is a quadratic equation having one positive and one negative root. The positive root is the one we require. The compression of the air inside the bell is then $b - x$.

(2) If A be the area of the section of the bell, the amount of water displaced is $A \cdot x$ and its weight is therefore wAx . Hence, if W be the weight of the bell, the tension of the chain

$$= W - wAx.$$

To make this result quite accurate, the weight of the contained air should be added to this result, but this weight is quite infinitesimal compared with the weight of the diving-bell

(3) Let V be the volume of the diving bell, and V' the volume of atmospheric air that must be forced in to keep the water level at D

In this case the pressure of the air within the bell

$$\begin{aligned} &= \text{pressure of the water at } D \\ &= w(b+a) + \Pi = w(a+b+h) \end{aligned}$$

Hence a volume $(V + V')$ at atmospheric pressure Π (i.e. $w h$) must occupy a volume V at pressure $w(a+b+h)$

Therefore, by Boyle's Law,

$$(V + V') h = V(a + b + h)$$

$$\therefore V' = V \frac{a+b}{h}, \text{ giving the required volume}$$

124 **Ex 1** *A cylindrical diving bell weighs 2 tons and has an internal capacity of 200 cubic feet, while the volume of the material composing it is 20 cubic feet. The bell is made to sink by attached weights. At what depth may the weights be removed and the bell just not ascend, the height of the water barometer being 33 feet?*

Let x be the required depth, so that the pressure of the air contained $= w(x+33)$, where w is the weight of a cubic foot of water

The volume of the air then $\times w(x+33)$

$$= 200 \times w \cdot 33, \text{ by Boyle's Law.}$$

Hence the volume of the water displaced (in cubic feet)

$$= 20 + \frac{200 \times 33}{x+33}$$

Also the weight of this water must be 2 tons

$$\therefore 2 \times 2240 = \left(20 + \frac{200 \times 33}{x+33}\right) \times 62\frac{1}{2},$$

$$\text{and thus } x = 94 \frac{229}{323} \text{ ft}$$

N B In this example the difference between the pressure of the water in contact with the air inside the bell and the pressure of the water at the bottom of the bell has been neglected

Ex 2 In the diving bell of Art 123 a soda-water bottle is opened, which in the external air would liberate a volume V of gas, shew that the tension of the rope is diminished by $\frac{whV}{\sqrt{(a+h)^2+4bh}}$, where squares of $\frac{V}{hA}$ are neglected

As in Art 123, we have

$$x^2 + r(a+h) - hb = 0 \quad \dots \quad (1)$$

When the bottle has been opened, let x become $x+y$. The original volume of the gas and air inside the bell would at pressure h occupy a length $b + \frac{V}{A}$ of the bell. Hence, by Boyle's Law,

$$(x+y)(x+y+a+h) = \left(b + \frac{V}{A}\right)h \quad (2)$$

Subtracting (1) from (2), we have

$$y[2r + a + h] = \frac{Vh}{A} \quad (3)$$

Since $\frac{Vh}{A}$ is small, it follows from this equation that y is small, and thus the square of y may be neglected. Hence (3) may be written

$$y[2r + a + h] = \frac{Vh}{A} \quad \dots \quad (4)$$

Now the original tension of the chain = $H - A x w$,
and the final tension = $W - A(x+y)w$

\therefore decrease in the tension

$$= A \cdot y \cdot w = \frac{Vwh}{2x+a+h}, \text{ by (4),}$$

$$= \frac{Vwh}{\sqrt{(a+h)^2+4bh}}, \text{ from (1).}$$

EXAMPLES XXV.

1. A cylindrical diving bell, whose height is 6 feet, is let down till its top is at a depth of 80 feet, find the pressure of the contained air, the height of the water barometer being $33\frac{1}{2}$ feet

2. How far must a diving bell descend so that the height of a barometer within it may change from 30 to 31 inches, assuming the sp gr. of mercury to be $13\frac{1}{2}$ and the bell to be kept full of air?

3. If the mercury in the barometer within a diving bell were to rise $12\frac{1}{2}$ inches, at what depth below the surface would the diving bell be? (sp gr of mercury = $13\frac{1}{2}$)

4. A cylindrical diving bell, whose height is 9 feet, is lowered till the level of the water in the bell is 17 feet below the surface. The height of the water barometer being 34 feet, find the depth of the bottom of the bell. If the area of the section of the bell be 25 square feet, find how much air at atmospheric pressure must be pumped into the bell to drive out all the water.

5. A diving bell having a capacity of 125 cubic feet is sunk in salt water to a depth of 100 feet. If the sp gr of salt water be 1.02 and the height of the water barometer be 34 feet, find the total quantity of air at atmospheric pressure that is required to fill the bell.

6. The bottom of a cylindrical diving bell is at rest at 17 feet below the surface of water, and the water is completely excluded by air pumped in from above. Compare the mass of air now in the bell with that which it would contain at the atmospheric pressure, the water barometer standing at 34 feet.

7. A cylindrical diving bell, 10 feet high, is sunk to a certain depth, and the water is observed to rise 2 feet in the bell. As much air is then pumped in as would fill $\frac{67}{440}$ ths of the bell at atmospheric pressure, and the surface of the water in the bell sinks one foot. Find the depth of the top of the bell and the height of the water barometer.

8. The height of the water barometer being 33 feet 9 inches and the sp gr of mercury $13\frac{1}{2}$, find at what height a common barometer will stand in a cylindrical diving bell which is lowered till the water fills one-tenth of the bell. How far will the surface of the water in the bell be below the external surface of the water?

9. A diving bell is lowered into water at a uniform rate, and air is supplied to it by a force pump so as just to keep the bell full without allowing any air to escape. How must the quantity, i.e. mass, of air supplied per second vary as the bell descends?

10. A cylindrical diving bell of height $\frac{h}{4}$ is sunk into water till its lower end is at a depth nh below the surface, if the water fill $\frac{1}{5}$ th of the bell, prove that the bell contains air whose volume at atmospheric pressure would be $\frac{4}{5} \left(n + \frac{19}{20} \right) V$, where V is the volume of the bell and h is the height of the water barometer.

11. A cylindrical diving bell is lowered in water and it is observed that the depth of the top when the water fills $\frac{1}{3}$ of the inside is $3\frac{1}{3}$ times the depth when the water fills $\frac{1}{4}$ of the inside, prove that the height of the cylinder is $\frac{1}{3}$ of the height of the water barometer.

12. A small hole is made in the top of a diving bell, will the water flow in or will the air flow out?

13. A small piece of wood floats half immersed in water, how much of it will be immersed in the water inside a diving bell, 10 feet high and 8 feet in diameter, which is lowered till its top is 47 feet below the surface of the water, the height of the water barometer being 34 feet and the sp gr of an at atmospheric pressure being σ ?

14. A conical diving bell, of which the axis is of length 16 feet, is let down into water, and it is found that when the vertex is $33\frac{2}{3}$ feet below the surface the water has risen within the bell to a height of 4 feet. Find the height of the water barometer.

15. A cylindrical diving bell is lowered to such a depth that the confined air occupies two-thirds of its interior, half as much air again is now pumped into the bell. How much further must the bell descend before it is half full of water?

16. A diving bell, whose height is b feet, contains a mercury barometer, whose height is h inches when the bell is above the surface of the water, and h' inches when it is below, to what height is the top of the bell submerged when its shape is (1) conical, and (2) cylindrical?

17. An open vessel, whose density is greater than that of water, is pushed with its mouth downwards into water, after a certain depth has been reached, shew that the equilibrium will be unstable.

18. A cylindrical diving bell, of height a , is lowered till its top is at a depth h below the surface of the water. If the bell be now half-full of water, and air be pumped in till all the water is expelled, prove that the bell must be lowered a further distance $4H - 2h$ before the bell is again half-full of water, H being the height of the water barometer.

19. A cylindrical diving bell, of height 10 feet and internal radius 3 feet, is immersed in water so that the depth of the top is 100 feet. Prove that, if the temperature of the air in the bell be now lowered from 20°C to 15°C and if 30 feet be the height of the water barometer at that time, the tension of the chain is increased by about 67 lbs.

****20.** A cylindrical diving bell, whose cross section is of area A , is suspended in water with its flat top at a distance a below the surface, the air inside the bell then occupying a length b of the bell. A man, of volume $A\alpha$ and sp gr s , who has been sitting on a platform inside the bell, falls into the enclosed water and floats. Shew that (1) the level of the water inside the bell rises, but that (2) the amount of water inside the bell is less than before.

Find also the change in the tension of the supporting chain

[The weight of the air displaced by the man may be neglected.]

(1) The volume of the air in the bell initially = $A(b - a)$

If $b - \beta$ be the length of the bell occupied by the air finally, the volume of the air then

= $A(b - \beta)$ - portion of the man above the water

= $A(b - \beta) - (A\alpha - A\alpha s)$, since $A\alpha s$ is the volume of the water displaced by the man,

= $A(b - \beta - \alpha + \alpha s)$

Hence if Π' , Π'' be the pressures of the air initially and finally we have, by Boyle's Law,

$$A(b - a) \times \Pi' = A(b - \beta - \alpha + \alpha s) \times \Pi''$$

But, as in Art 12;

$$\Pi' = w(b + a + h) \text{ and } \Pi'' = w(b - \beta + a + h),$$

where h is the height of the water barometer

Hence

$$(b - a)(b + a + h) = (b - \beta - \alpha + \alpha s)(b - \beta + a + h) \\ \beta^2 - \beta[2b + a + h - \alpha + \alpha s] + \alpha s(b + a + h) = 0 \quad (1)$$

This is a quadratic equation for β . Its second term is clearly negative, and its third term is positive. Hence its roots are positive.

Thus β is positive.

Hence the level of the water rises.

(2) If H be the total height of the bell, the amount of water in it initially = $A(H - b)$

The amount finally

$$= A[H - (b - \beta)] - \text{amount of water displaced by the man} \\ = A[H - b + \beta] - A\alpha s$$

Thus amount of water initially - amount finally

$$= A\alpha s - A\beta = -A(\beta - \alpha s) \quad \dots \dots (2)$$

But equation (1) can be written

$$(\beta - \alpha s)(\beta - 2b - a - h + \alpha) = \alpha s(b - a).$$

The second factor on the left-hand side is clearly negative, and the right-hand side is positive,

$\beta - \alpha s$ is negative

Hence the right-hand side of (2) is positive.

Hence initially the amount of the water in the bell is greater than the final amount

(3) Tension of the chain initially

= wt of the bell + wt of the man - wt of the water displaced

= $W + A\alpha s w - A\beta w$

Tension of the chain finally = $W - A(b - \beta)w$

\therefore Initial tension - final tension

= $A\alpha s w - A\beta w = Aw(\alpha s - \beta)$ = positive, as in (2).

The tension of the chain is therefore diminished

21 A diving bell is immersed in water so that its top is at a depth a below the surface, the height of the air within the bell being then τ and the height of the water barometer being h . If a bucket of water, of small weight W , be now drawn up into the bell, prove that the tension of the chain is increased by $\frac{Wx}{h+a+2\tau}$ approximately

22. If a cylindrical diving bell, of height a and of such internal volume that it would contain a weight W of water, be lowered so that the depth of its highest point is d , prove that, when the temperature is raised from $t^\circ \text{C}$ to $t_1^\circ \text{C}$, the tension of the supporting chain is diminished by $\frac{\alpha(t_1 - t)}{1 + \alpha t} \frac{Wh}{\sqrt{(h+d)^2 + 4ah}}$ nearly, h being the height of the water barometer and $a = \frac{1}{2} \frac{W}{\rho g}$

23. A diving bell in the shape of a cone of height a , be lowered till its vertex is at a depth d , prove that the height x of the part of the bell occupied by the air is given by the equation $x^4 + x^3(h+d) = a^3h$, where h is the height of the water barometer

If the temperature of the air inside be now raised from T° to $(T+t)^\circ$, prove that the tension of the supporting chain is diminished by $\frac{3athW}{3h+3d+4x}$, where W is the weight of the water the cone would contain, and α is the coefficient of expansion, the squares of a being neglected

24. A cylindrical diving bell, of height b , is immersed in water with its highest point at a depth a below the surface, if the barometer rises so that the increase of the pressure on its top is P , shew that the alteration in the tension of the chain is approximately

$$\frac{P}{2} \left[1 - \frac{a+h}{\sqrt{(a+h)^2 + 4bh}} \right],$$

where h is the height of the water barometer.

125 Syringe The simplest form of the pump is seen in an ordinary syringe

It consists of a hollow cylinder *AB* at whose end is a nozzle *C*. Within this cylinder there works an air tight piston. The end of the syringe *C* is placed under the surface of a liquid and the piston raised, the pressure of the air forces the liquid up into the cylinder to fill the vacuum which would otherwise be formed below the piston.

When sufficient liquid has been raised the syringe is taken out, and the liquid ejected again through the nozzle *C* by reversing the motion of the piston.

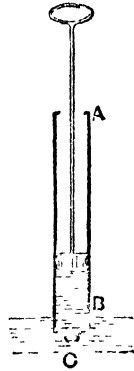

126 The principle of all pumps is that of suction. A partial vacuum is created and the atmospheric pressure forces the liquid in to fill up this partial vacuum. This principle was by the older philosophers expressed by saying that *Nature abhors a vacuum*. It was later found that this abhorrence extended in the case of water to a height of not more than about 34 feet.

127. Valves are used in suction pumps and in the construction of air pumps.

They are made so as to allow water, air, &c to pass through the holes, which they close, in one direction but not in the other; but there is always some leakage even with the best valves.

In an ordinary pair of bellows the valve is a leather flap closing a circular hole, this allows air to enter when

the bellows is being expanded, when the bellows are compressed the leather is pressed down tightly on the hole, and the air cannot pass out.

The valves N and F in Art 128 are generally circular discs of metal turning round a hinge at their edges. In the case of the air-pumps, the valves usually consist of a portion of oiled silk, secured at both ends to a plate of brass in which is a narrow slit through which the air passes. The silk is adjusted so that its central part is over the slit. When the pressure on the far side of the plate is the greater, the silk lifts, and air passes in. When the pressure on the near side is the greater, the silk is pressed tightly down over the slit, and the latter becomes air-tight.

Another valve is shewn at F in Art 146, it consists of a metal ball which accurately fits a circular hole, this is lifted when the pressure below exceeds that above.

Theoretically a valve should lift when there is any excess of pressure on one side, practically in any valves there must be a small excess of pressure before it will lift.

128. The Common or Suction Pump This pump consists of two cylinders, AB and BC , the upper cylinder being of larger sectional area than the lower, and the lower cylinder being long and terminating beneath the surface of the water which is to be raised.

Inside the upper cylinder works a vertical rod terminating in a piston DE , fitted with a valve F which only opens upwards.

This piston can move vertically from B to L where the spout of the pump is. At B , the junction of the two cylinders, there is a valve N which also only opens upwards.

The rod is worked by a lever GHK , straight or bent, H being the fulcrum and K the end at which the force is applied.

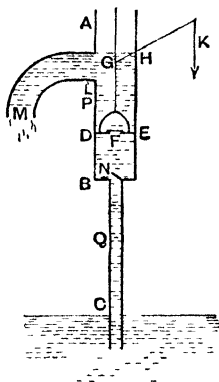

Action of the Pump Suppose the piston to be at the lower extremity of the upper cylinder and that the water has not risen inside the lower cylinder

By a vertical force applied at K the piston DE , raised, the valve F therefore remaining closed. The air between the piston and the valve N becomes rarefied and its pressure therefore less than that of the air in BC .

The valve N therefore rises and air goes from BC into the upper cylinder. The air in BC in turn becomes rarefied, its pressure becomes less than atmospheric pressure, and water from the reservoir rises into the cylinder CB .

When the piston reaches L its motion is reversed. The air between it and N becomes compressed and shuts down the valve N . When this air has been compressed, so that its pressure is greater than that of the atmosphere, it

till the piston is at B when the first complete stroke is finished

Other complete strokes follow, the water rising higher and higher in the cylinder CB until its level comes above B , provided that the height CB be less than the height of the water barometer. This is the one absolutely essential condition for the working of the pump

[In practice, on account of unavoidable leakage at the valves, the height CB must be a few feet less than the height of the water barometer]

At the next stroke of the piston some water is raised above it and flows out through the spout LM . At the same time the water below the piston will follow it up to L , provided the height CL be less than that of the water barometer

[If this latter condition be not satisfied the water will rise only to some point P between B and L and in the succeeding strokes only the amount of water occupying the distance BP will be raised]

129. The two cylinders spoken of in the previous article may be replaced by one cylinder provided that a valve, opening upwards, be placed somewhat below the lowest point of the range of the piston

The lower cylinder need not be straight but may be of any shape whatever, provided that the height of its upper end B above the level of the water be less than the height of the water barometer

The height of the water barometer being usually about 33 feet, the lowest point of the range of the piston must be at a somewhat less height than this above the reservoir so that the pump may work

130. *Tension of the Piston rod*

Let A be the area of the piston, h the height of the water barometer, and w the weight of a unit volume of water.

The tension of the piston rod must overcome the difference of the pressures on the upper and lower surfaces of the piston.

First, let the water not have risen to the point B but let its level be Q .

The pressure of the air above Q

$$= \text{pressure of the water at } Q$$

$$= \text{pressure at } C - w \cdot CQ = w(h - CQ)$$

The pressure on the lower surface of the piston therefore equals $A \times w(h - CQ)$ and that on the upper is equal to $A \times wh$. Hence, if T be the required tension, we have

$$T + A \cdot w(h - CQ) = A \cdot wh.$$

$$\therefore T = A \times w \cdot CQ$$

Secondly, let the water have risen to a point P which is above the valve N

The pressure at a point on the upper surface of the piston

$$= w \cdot DP + wh = w(h + DP)$$

The pressure at a point on the lower surface

$$= wh - w \cdot CD = w(h - CD)$$

Hence we have

$$T + A \cdot w(h - CD) = A \cdot w(h + DP)$$

$$\therefore T = A \cdot w \cdot CP.$$

Hence, in both cases, *the tension of the rod is equal to the weight of a column of water, whose sectional area is equal to that of the piston, and whose height is equal to the distance between the levels of the water within and without the pump.*

131. To find the distance through which the water is raised during the n th stroke of the piston.

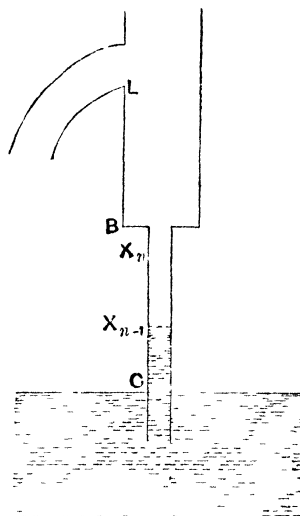

With the figure and notation of Art 128, let X_{n-1} be the point the water has reached at the beginning of the n th stroke, and X_n the point at the end of this stroke. Let $CX_{n-1} = x_{n-1}$ and $CX_n = x_n$

Let $BL = l$, and let the length CB of the pipe = c

Let A be the area of the section of the barrel BL , and a that of the pipe CB

When the surface of the water is at X_{n-1} and the piston at B , let Π' be the pressure of the air above X_{n-1} , and Π that of the external air

$$\therefore \Pi = \Pi' + wx_{n-1} \quad (\text{Art 31}) \quad \dots \quad (1)$$

When the surface of the water is at X_n and the piston at L , let Π'' be the pressure of the air above X_n , then

$$\Pi = \Pi'' + w x_n \quad . \quad (2)$$

Now at the beginning of the stroke the air inside the pump occupied the length $X_{n-1}B$ of the pipe and its volume was therefore $a \times X_{n-1}B$, i.e. $a(c - x_{n-1})$

At the end of the stroke this same air occupied the length X_nB of the pipe and the length BL of the barrel, so that its volume was then

$$a \times X_nB + A \times BL,$$

i.e.

$$a(c - x_n) + A \times l$$

Hence, by Boyle's Law, we have

$$\Pi' \times \{a(c - x_{n-1})\} = \Pi'' \{a(c - x_n) + Al\} \quad (3)$$

Hence, by (1) and (2),

$$(\Pi - wx_{n-1}) \times a(c - x_{n-1}) = (\Pi - wx_n) \{a(c - x_n) + Al\}$$

But, if h be the height of the water barometer, $\Pi = wh$, and hence

$$a(h - x_{n-1})(c - x_{n-1}) = (h - x_n) \{a(c - x_n) + Al\} \quad (4)$$

This is a quadratic equation to give x_n when x_{n-1} is known

Giving n in succession the values 1, 2, 3, we have the heights to which the surface of the water has risen at the end of the 1st, 2nd, 3rd strokes (since $x_0 =$ height of the water above C at the beginning of the first stroke = 0), given by the equations

$$ahc = (h - x_1) \{a(c - x_1) + Al\},$$

$$a(h - x_1)(c - x_1) = (h - x_2) \{a(c - x_2) + Al\},$$

$$a(h - x_2)(c - x_2) = (h - x_3) \{a(c - x_3) + Al\},$$

etc.

132. If the n th stroke be the last complete stroke that is made before the water enters the barrel, the preceding article must be slightly modified

At the end of the $(n + 1)$ th stroke, let the height of the surface of the water above B be y . Then the equations (1) and (2) of the last article become

$$\Pi = \Pi' + wx_n \quad \dots \quad (1)$$

$$\Pi = \Pi'' + w(c + y) \quad (2)$$

Also the volume $a(c - x_n)$ of air has expanded to the volume

$$A(BL - y),$$

i.e.

$$A(l - y)$$

Hence, by Boyle's Law,

$$\Pi'' \times A(l - y) = \Pi' \times a(c - x_n);$$

$$\therefore [\Pi - w(c + y)] \times A(l - y) = (\Pi - wx_n) \times a(c - x_n),$$

i.e.

$$A(h - c - y)(l - y) = a(h - x_n)(c - x_n),$$

an equation to give y

At the next stroke the water passes out at L

133 Ex 1 If the barrel of a common pump be 18 inches long and its lower end 21 feet above the surface of the water, and if the section of the pipe be $\frac{3}{14}$ ths of that of the barrel, find the height of the water in the pipe at the end of the first stroke, assuming the height of the water barometer to be 32 feet.

Let A and $\frac{3}{14}A$ be the areas of the sections of the barrel and pipe respectively, and let x feet be the required height. The original volume of the air in the pump = $\left(\frac{3}{14}A \times 21\right)$ cub. ft. = $\frac{9A}{2}$ cub. ft. At the end of the first up stroke the volume

$$= \frac{3}{14}A \times (21 - x) + A \times \frac{3}{2} = A \left[6 - \frac{3x}{14}\right].$$

Its pressure then, by Boyle's Law,

$$= \Pi \frac{\frac{9A}{2}}{A \left(6 - \frac{3x}{14}\right)} = \Pi \frac{21}{28 - x},$$

where Π is the external atmospheric pressure. Hence a column x of water is supported, the pressure at the bottom being Π and that at the top being $\Pi \frac{21}{28-x}$.

$$\Pi = wx + \Pi \frac{21}{28-x}.$$

But $\Pi = w \cdot 32$

$$(32-x)(28-x) = 21 \times 32$$

$$\therefore x^2 - 60x + 224 = 0.$$

$$\therefore x = 4 \text{ feet}$$

Ex 2 If the barrel of a common pump be 2 feet long, and its lower end be 26 feet above the surface, and if the area of the section of the barrel be 6 times that of the pump, find in how many strokes the water will reach the barrel, the height of the water barometer being 32 feet

Here $l=2$, $c=26$, $A=6a$, $h=32$

Hence the equation (4) of Art 131 becomes

$$\begin{aligned} (32 - x_{n-1})(26 - x_{n-1}) &= (32 - x_n)[26 - x_n + 6 \times 2] \\ &= (32 - x_n)(38 - x_n) \end{aligned}$$

Hence $x_n = x_{n-1} + 6$

[The other root would be found to be $64 - x_{n-1}$, which is clearly inadmissible]

Now $x_0 = ht$ at commencement of the working $= 0$.

$$x_1 = x_0 + 6 = 6, \quad x_2 = x_1 + 6 = 12$$

So $x_3 = 18$, $x_4 = 24$, $x_5 = 30$, which is greater than the length of the pipe

Hence the water at the end of the fifth stroke has reached the barrel

Thus at the end of the sixth stroke it will flow out of the spout

134. Lifting Pump. This is a modification of the common pump. The top of the pump-barrel is in this case closed and the piston rod works through a tight collar which will allow neither air nor water to pass.

The spout is made of smaller section than in the common pump, instead of turning downwards it turns up and conducts the water through a vertical pipe to the height required

The spout is furnished at *E* with a valve which opens outwards

As the piston rises this valve opens and the water enters the spout. When the piston descends this valve closes and opens again at the next upward stroke

By this process the water can be lifted to a great height provided the pump be strong enough

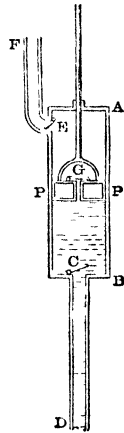

135 Forcing Pump. In this pump the piston *DE* is solid and has no valve. The lower barrel *BC* has a valve at *B* opening upward as in the common pump.

There is a second valve *F* at the bottom of the upper barrel opening outward and leading to a vertical pipe *GH*

In its descending stroke the piston drives the air through *F*, and in its ascending stroke the valve *F* is closed, *N* is opened, and the water rises in *CB* as in the common pump

When the level of the water is above *B* the piston in its descending stroke drives the water through *F* up into the tube *GH*. In the ascending stroke of the piston the valve *F* closes and prevents the water in *GH* from returning

In this manner after a succession of strokes the water

is raised to a height which depends only on the pressure on the piston and the strength of the pump

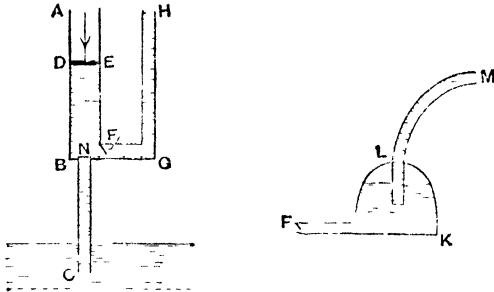

The flow in the forcing pump as just described will be intermittent, the water only flowing during the downward stroke of the piston

To obtain a continuous stream the pipe from *F* leads into another chamber partially filled with air. From this chamber a tube *LM*, whose end is well below the air in the chamber, leads up to the height required

When the piston *DE* is on its downward stroke the air in this chamber is being compressed at the same time that water is being forced up the tube *LM*

When the piston is on its upward stroke and the valve *F* therefore closed, this air being no longer subjected to the pressure caused by the piston endeavours to recover its original volume. In so doing it keeps up a continuous pressure on the water in the air chamber and forces this water up the tube, thus keeping up a continuous flow

136. Fire-engine The "manual" fire-engine is essentially a forcing pump with an air chamber.

There are however two barrels AB and $A'B'$ each connecting with the air vessel, and two pistons, D and D' , one of which goes down whilst the other goes up.

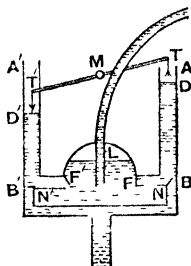

The ends T and T' of the piston rods are attached to the ends of a bar TMT' , which can turn about a fixed fulcrum at M

A practically constant stream is thus obtained, for the air chamber maintains the flow at the instants when the pistons reverse their motion

EXAMPLES. XXVI.

1. The height of the barometer column varies from 28 to 31 inches. What is the corresponding variation in the height to which water can be raised by the common pump, assuming the sp gr of mercury to be 13.6?

2. If the water barometer stand at 33 ft. 8 ins. and if a common pump is to be used to raise petroleum from an oil-well, find the greatest height at which the lower valve of the pump can be placed above the surface of the oil in the well. The sp gr of petroleum is .8

3. A tank on the sea-shore is filled by the tide whose sp gr is 1.025. It is desired to empty it at low tide by means of a common pump whose lower valve is on the same level as the top of the tank. Find the greatest depth which the tank can have so that this may be possible when the water barometer stands at 34 ft. 2 ins.

4. One foot of the barrel of a pump contains 1 gallon (10 lbs.) At each stroke the piston works through 4 inches. The spout is 24 feet above the surface of the water in the well, how many foot-pounds of work are done per stroke?

5. If the fixed valve of a pump be 29 feet above the surface of the water, and the piston, the entire length of whose stroke is 6 inches, be when at the lowest point of its stroke 4 inches from the fixed valve, find whether the water will reach the pump barrel, the height of the water barometer being 32 feet.

6. If the length of the lower pipe of a common pump above the surface of the water be 16 feet and the area of the barrel of the pump 16 times that of the pipe, find the length of the stroke so that the water may just rise into the barrel at the end of the first stroke, the water barometer standing at 32 feet. If the length of the stroke of the piston be one foot, find the height to which the water will rise at the end of the first stroke.

7. A lift pump is employed to raise water through a vertical height of 200 feet. If the area of the piston be 100 square inches, what is the greatest force, in addition to its own weight, that will be required to lift the piston?

8. The area of the piston in a force pump is 10 square inches and the water is raised to a height of 60 feet above the piston. Find the force required to work the piston.

9. A forcing pump, the diameter of whose piston is 6 inches, is employed to raise water from a well to a tank. If the bottom of the piston be 20 feet above the surface of the water in the well and 100 feet below that of the water in the tank, find the least force to (1) raise, (2) depress the piston, the friction and weights of the valves being neglected, and the height of the water barometer being 32 feet.

10. Find the work done in each stroke of a common pump after the water has risen to the spout.

11. A force pump is used to suck water from a depth of 4 metres and drive it to a height of 60 metres, if the diameter of the plunger be 20 cms, find the force on the piston rod both in the backward and forward strokes.

12. The cylinder and barrel of a common pump have the same sectional area. If the level of the water in the cylinder is raised through the same distance in each of the first two strokes of the piston, prove that the height of the water barometer is the arithmetic mean between the greatest and least distances of the piston from the surface of the water in the well.

13. The lower valve of a common pump is 10 feet above the water, and the area of the barrel is five times that of the pipe leading to the well, if the height of the water barometer be 34 feet and the water just rise up to the level of the lower valve at the end of the first stroke, find the distance through which the piston moves.

14. The lower valve of a pump is at a height of 28 feet above the water in the well, and the whole length of the stroke of the piston is 9 inches, and when the piston is at its lowest point it is 3 inches from the lower valve, will the water ever rise into the pump-barrel, the height of the water-barometer being 34 feet? What is the greatest height to which the water will rise?

[When the piston does not go quite home to the valve at the bottom of the barrel, it is thus seen that the depth from which water can be raised is lessened.]

15. In the common pump, shew that the water will rise into the upper cylinder at the end of the second stroke, if

$$h^2 \left[1 - \frac{c}{nl} \right] \left[2 - \frac{c}{nl} \right] - h \left[4c + nl - \frac{3c^2}{nl} \right] + c(2c + nl) = 0,$$

where c , l are the lengths of the lower and upper cylinder, n is the ratio of the area of the cross-section of the latter to that of the former, and h is the height of the water barometer

137. Air-pumps form another class of machines. Their use is to pump the air out of a vessel in which a vacuum is desired.

Smeaton's Air-Pump This Pump consists of a cylinder CB having valves opening upwards at C and B , within which there works a piston D having a valve which also opens upwards.

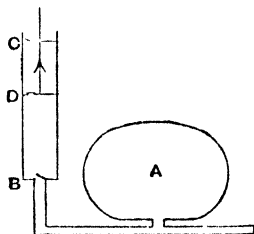

The valves must be very carefully constructed to be as air-tight as possible.

The lower end B is connected by a pipe with the vessel, or receiver, A , which is to be emptied of air.

Suppose the working to commence with the piston at B . The piston is raised and a partial vacuum thus formed between it and B , the pressure of the air below B opens the valve at B and air from the receiver follows the piston.

At the same time the air above D becomes condensed, opens the valve at C , and passes out into the atmosphere.

When the piston is at C its motion is reversed, the air between it and B becomes compressed, shuts the valve B , and opens the valve at D . The air that was between the piston and B therefore passes through the piston valve and occupies the space above the piston.

Thus in one complete stroke a quantity of air has been removed from below B .

In each succeeding stroke the same volume of air (but at a diminishing pressure) is removed, and the process can be continued until the pressure of the air left in the receiver is insufficient to raise the valves.

The advantage of the valve at C is that during the downward stroke of the piston the pressure of the air above it becomes much less than atmospheric pressure, and hence the piston-valve is more easily raised than would otherwise be the case.

Also the work which the piston has to do during its upward stroke is considerably lessened.

138 *Rate of Exhaustion of the Air* Let v be the volume of the receiver (including the passage leading from the receiver to the lower valve of the cylinder), and V' be the volume of the cylinder between its higher and lower valves.

Let ρ be the original density of the air in the receiver, and ρ_1 the density after the first half stroke. The air

which originally occupied a volume V of density ρ now occupies a volume $(V + V')$ and is of density ρ_1

$\therefore V \rho = (V + V') \rho_1$, by Boyle's Law,

$$\text{i e.} \quad \rho_1 = \frac{V}{V + V'} \rho \quad \dots \quad (1)$$

When the piston has descended to B again a volume V has escaped, so that we now have a volume V in the receiver of density ρ_1

The process is now repeated. Hence, if ρ_2 be the density in the receiver after the second complete stroke, then

$$\rho_2 = \frac{V}{V + V'} \rho_1 = \left(\frac{V}{V + V'} \right)^2 \rho$$

So the density after the third complete stroke

$$= \left(\frac{V}{V + V'} \right)^3 \rho,$$

and the density after the n th stroke = $\left(\frac{V}{V + V'} \right)^n \rho$.

This density is never zero, so that, even theoretically, a complete vacuum can never be obtained

A fairly good air-pump will give, in the limit, a pressure equal to about $\frac{1}{10}$ th inch of mercury in the receiver, about one quarter of this is the lowest limit that has probably been attained by an air-pump

Ex If the receiver be six times as large as the barrel, find how many strokes must be made before the density of the air is less than half of the original density

$$\begin{aligned} \text{Here} \quad \frac{V}{V + V'} &= \frac{6}{6 + 1} = \frac{6}{7} \\ \therefore \rho_1 &= \frac{6}{7} \rho, \quad \rho_2 = \left(\frac{6}{7} \right)^2 \rho = \frac{36}{49} \rho, \quad \rho_3 = \left(\frac{6}{7} \right)^3 \rho = \frac{216}{343} \rho, \\ \rho_4 &= \left(\frac{6}{7} \right)^4 \rho = \frac{1296}{2401} \rho, \quad \rho_5 = \left(\frac{6}{7} \right)^5 \rho = \frac{7776}{16807} \rho. \\ &\rho_4 > \frac{1}{2} \rho, \quad \text{and} \quad \rho_5 < \frac{1}{2} \rho \end{aligned}$$

Therefore 5 strokes must be made.

139 The double-barrelled or Hawksbee's Air-pump. This machine consists of two cylinders, each

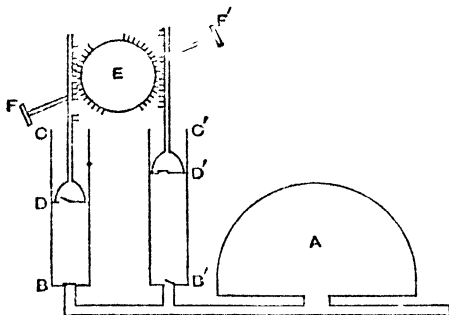

similar to the single cylinder in Smeaton's Pump and each furnished with a piston. These two pistons are both turned by a toothed wheel E , the teeth of which catch in suitable teeth provided in the pistons.

This wheel is turned by a handle $F'F''$.

As one piston goes up the other goes down. In the figure the left-hand piston is descending and the right-hand piston is ascending.

One advantage of this form of machine is that the resistance of the air which retards one piston has the effect of assisting the descent of the other.

The rate of exhaustion in Hawksbee's Pump can be calculated in a similar manner to that for Smeaton's Pump. In this case V' is the volume of each cylinder and n is the number of half strokes made by each piston, i.e. the number of times either piston traverses its cylinder, motions both in an upward and downward direction being counted.

Hawksbee's Air-Pump was also made with only one barrel, so that it was then like Smeaton's, except that it was open at the top of the cylinder

140 Mercury Gauge, or Manometer

The pressure of the air in the receiver is shown at any instant by an instrument called the mercury gauge

This has two common forms

In one form it is a small siphon barometer, consisting of a small bent tube with almost equal arms. One arm has a vacuum at *A* above the mercury, and the other arm is open at *C* and connected with the air in the receiver. As the pressure in the receiver diminishes the height of the mercury in the vacuum tube diminishes also, and the pressure of the air in the receiver is measured by the difference of the levels in the two arms of the gauge.

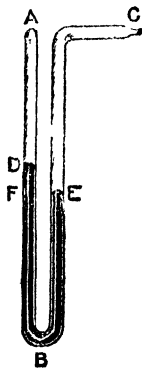

In another form it consists of a straight barometer tube, the upper end of which communicates with the receiver, and the lower end of which is immersed in a vessel of mercury open to the atmosphere. As the pressure of the air in the receiver diminishes the mercury is forced up this tube, and the height of the mercury in the tube measures the excess of the atmosphere pressure over the pressure of the air in the receiver

141. If h be the range of the piston in a Smeaton's Air-Pump, a the distance from the top of the barrel in its highest position, b the distance from the bottom in its lowest position, and ρ the density of the atmosphere, shew that the limiting density of the air in the receiver is

$$\frac{ab}{(h+a)(h+b)} \rho$$

When the piston D is in its lowest position at the commencement of any stroke, let σ_1 be the density of the air between it and B , and therefore also that of the air between it and C (Fig, Art 137)

Also let σ be the density inside the receiver

Then in order that the density σ may be further lessened, the valve at C must be raised during the next stroke, and so also must the valve at B

During the stroke the length of air $h+a$ at pressure σ_1 is reduced to a length a at pressure $\frac{h+a}{a}\sigma_1$, and thus the upper valve is raised if

$$\frac{h+a}{a}\sigma_1 > \rho. \quad \dots \quad (1)$$

Also the length of air b at pressure σ_1 is during the same stroke allowed to expand to length $h+b$ at pressure $\frac{b\sigma_1}{h+b}$, and thus the lower valve is raised if

$$\sigma > \frac{b\sigma_1}{h+b} \quad (2)$$

From (1) and (2) we have

$$\sigma > \frac{b}{h+b} \times \frac{a\rho}{h+a} > \frac{ab}{(h+a)(h+b)} \rho$$

Thus the density of the air inside the receiver can never be reduced below $\frac{ab}{(h+a)(h+b)} \rho$, the pump will cease working when the density has this value

Hence it is clear that it is necessary to push the piston well home at the end of each stroke. This is especially the case when the density of the air in the receiver is approaching its limit

The length, a or b , of the barrel which is untraversed by the piston is called the "clearance"

[The weights of the valves have been neglected.]

It follows, similarly, that in a Hawksbee's air pump the limiting density is $\frac{b}{h+b} \rho$ where b is the distance of the piston in its lowest position from the bottom of the barrel, and h is the length of its stroke

142 The Air-condenser, or Condensing Air-pump. The object of this instrument is exactly opposite to that of the Air-pump, viz to increase the pressure of the air in a vessel instead of diminishing it.

The condenser consists of a vessel *A*, to which is attached a cylinder *CB*, in which works a piston *D*. In the piston *D* and at *B* (between *D* and the vessel *A*) are valves, both of which *open downwards*

When the piston is pressed down, the air between *D* and *B* becomes condensed, opens the valve *B*, and is forced into the vessel *A*.

When the piston gets to *B* its action is reversed, the atmosphere outside presses the valve *D* open, and the pressure inside *A*, being now greater than that of the air between *B* and the piston, shuts the valve *B*

When the piston gets to the highest point of its range, the motion is again reversed, and more air is forced into *A*

The vessel *A* is provided with a stop-cock *E*, which can be used to close *A* when it is desired.

A slightly different form of condenser is one form of pump used for inflating the tyres of bicycles. The piston rod *DC* is hollow and is attached at *C* to the entrance to the tyre

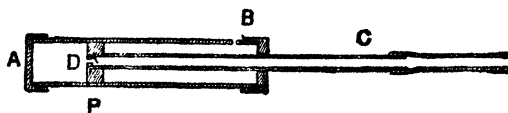
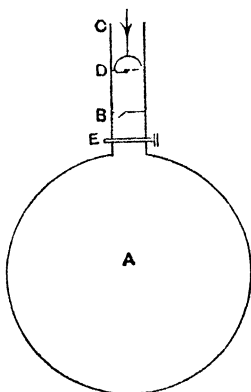

It contains a valve at *D*. When the piston is at the end of the cylinder at *B*, air enters through the hole *B* behind the piston. The cylinder is then pushed forward and the

piston D moves past B and cuts off communication with the atmosphere, as the cylinder is still further pushed forward the air in AD is compressed and forced through D into the piston-rod DC and so through the tyre-valve into the tyre

The hole at B is often omitted. The end of the piston at D is furnished with a circular piece of leather, somewhat similar to that on Page 187, which fits closely to the cylinder. This leather allows air to pass when the cylinder is pulled back, but not when it is pushed forward. The connection with the outer air is then made by a small hole at the end of the cylinder at B .

143. Density of the Air in the Condenser Let V be the volume of the vessel A , including that portion of the cylinder below the valve B , and V' that of the cylinder between the valve B and the highest point of the range of the piston

In each stroke of the piston a volume V' of air at atmospheric pressure is forced into the condenser

Hence at the end of n strokes there is in the condenser a quantity of air which would occupy a volume $V + nV'$ at atmospheric pressure

If ρ be the original density of the air and ρ_n the density after n strokes, we have

$$\rho (V + nV') = \rho_n V$$

$$\therefore \rho_n = \frac{V + nV'}{V} \rho$$

Ex A condenser and a Smeaton's Air pump have equal barrels and the same receiver, the volume of either barrel being one-tenth of that of the receiver, if the condenser be worked for 8 strokes and then the pump for 6 strokes, prove that the density of the air in the receiver will be approximately unaltered

If ρ be the original density, the density at the end of 8 strokes of the condenser = $\frac{V + 8 \cdot \frac{1}{10}V}{V} \rho = \frac{18}{10} \rho$.

Also the density at the end of 6 strokes of the pump

$$\begin{aligned} &= \frac{18}{10} \rho \times \left(\frac{V}{V + \frac{1}{10} V} \right)^6 = \frac{18}{10} \rho \times \frac{10^6}{11^6} \\ &= \frac{1800000}{1771561} = 1.016 \rho \end{aligned}$$

Hence the final density is very nearly equal to the original density

144. Tate's Air-Pump. This is a form of pump in common use. It consists of a pair of pistons, A and B , connected by a rod with a handle F . The distance between the extreme faces of A and B is very slightly less than half the length of the cylinder CD . At E , the middle point of the cylinder, a passage leads to the receiver from which the air is to be expelled. When B is at D , the piston A is just

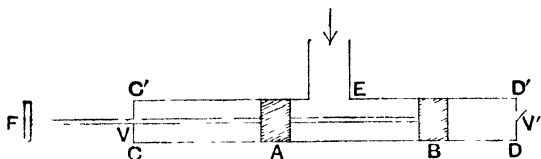

to the right of E (since the distance between the extreme faces is less than $\frac{1}{2} C'D'$). At V and V' are two valves, both opening outwards.

In the figure the piston B is moving towards D' and driving the air out at V' . When B gets to D' , E is placed in communication with the space to the left of A , on the motion being reversed the valve V' closes, and the air to the left of A is compressed till its pressure is greater than atmospheric pressure, the valve V then opens, and lets this air out.

When A gets to C , the passage E is in communication with the space to the right of B and some of the air in the receiver expands into this space, and at the next stroke forward of the piston is forced out through V' .

The handle being worked alternately forward and backward, the air in the receiver is thus exhausted

This form of pump has advantage over Smeaton's form in that two valves, one in the piston and one leading to the receiver, are not wanted. A greater degree of exhaustion can thus be produced

145 When a very high degree of exhaustion is required, as in the case of the globes of electric lamps, the preceding air-pumps are not sufficient, as the necessity of lifting the valves sets a limit to their working. Other pumps must be used, one such is **Sprengel's Air-Pump**. This machine consists of a vertical glass tube ABC , the lower end of which dips into a vessel G containing mercury, and the upper end of which connects with a vessel E containing mercury. At B a glass tube connects with the receiver which is to be exhausted. The length BG must be greater than the height of the mercury barometer. The mercury in E is allowed to run down through ABC , as the mercury passes B it breaks into drops, and encloses portions of air which come from the receiver through the tube DB , this air is carried down into the mercury G , and so passes into the atmosphere

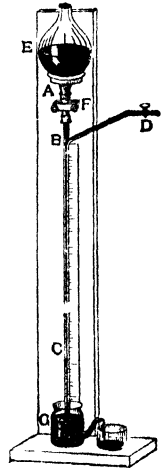

As this process continues the pressure of the air in BD diminishes, until the metallic sound caused by the falling drops of mercury shews that practically no air is carried down with it. The height above G at which the mercury then stands inside the tube BG is very nearly equal to the height of the mercury barometer.

The vessel E must not be allowed to become empty, the mercury overflows from G into another vessel, and this latter is continually being used to replenish the amount in the vessel E

EXAMPLES XXVII.

1. Find the ratio of the receiver of Smeaton's Air-pump to that of the barrel, if at the end of the fourth stroke the density of the air in the receiver is to its original density as 81 : 256

2. The cylinder of a single-barrelled air-pump has a sectional area of 1 square inch, and the length of the stroke is 4 inches. The pump is attached to a receiver whose capacity is 36 cubic inches. After eight complete strokes compare the pressure of the air in the cylinder with its original pressure

3. In one air-pump the volume of the barrel is $\frac{1}{10}$ th of that of the receiver and in another it is $\frac{1}{5}$ th of the receiver. Shew that after three ascents of the piston the densities of the air in the two receivers are as 1728 : 1331

4. If each of the barrels of a double-barrelled air-pump has a volume equal to one-tenth of that of the receiver, what diminution of pressure will be produced in the receiver after four complete strokes of the handle of the pump?

5. If the receiver of an air-pump be six times as large as the barrel, find how many strokes must be made before the density of the air is less than (1) $\frac{1}{2}$, (2) $\frac{1}{3}$ of the original density

6. In one pump the barrel has $\frac{1}{12}$ th of the volume of the receiver and in another it has $\frac{1}{6}$ th. How many strokes of the latter are required to produce the same degree of exhaustion as six of the former?

7. In the process of exhausting a certain receiver after ten strokes of the pump the mercury in a siphon gauge connected with the receiver stands at 20 inches, the barometer standing at 30 inches. At what height will the mercury in the gauge stand after 20 more strokes?

8. If the piston of an air-pump have a range of 6 inches and at its highest and lowest positions be one-fourth of an inch from the top and bottom of the barrel respectively, prove that the pressure of the air in the receiver cannot be reduced below $\frac{1}{25}$ th of atmospheric pressure.

9. If the capacity of the barrel of a condensing air pump be 80 cubic cms. and the capacity of the receiver 1000 cubic cms, how many strokes will be required to raise the pressure of the air in the receiver from one to four atmospheres?

10. The barrel of a condensing air-pump is one inch in diameter and 8 inches long. The tube of a pneumatic tyre when inflated is one inch in diameter and 80 inches long. If to begin with the tyre is quite empty, how many strokes of the pump will be needed to inflate it with air at twice the atmospheric pressure?

11. In a condenser the area of the piston is 5 square inches and the volume of the receiver is ten times as great as the volume of the range of the piston. If the greatest intensity of the force that can be used to make the piston move be 165 lbs wt, find the greatest number of complete strokes that can be made, the pressure of the atmosphere being taken to be 15 lbs wt per sq in

12. If of the volume B of the cylinder of a condenser only C is traversed by the piston, prove that the pressure in the receiver cannot be made to exceed $\frac{B}{B-C}$ atmospheres

13. The capacity of the receiver of a Smeaton's Air-pump is eight times that of the barrel, what fraction of the fifth upward stroke has the piston described when the upper valve opens?

14. If the upper valve in a Smeaton's Air-pump opens when the piston is three-quarters of the way up, what was the density of the air in the receiver at the commencement of the stroke?

15. A speaking tube, whose section is one square inch in area, is found to be blocked. A condensing pump is attached to the tube, and after 30 strokes the pressure of the air in the tube is found to be 4 times that of the atmosphere. If the capacity of the barrel of the pump be 50 cubic inches, shew that the obstruction is distant $41\frac{2}{3}$ feet from the mouth of the tube

16. A condenser and a Smeaton's Air-pump have equal barrels and the same receiver, the volume of the latter being twenty times that of either barrel, if the condenser be worked for 20 strokes, and then the pump for 14, shew that the density of the air in the receiver will be approximately what it was to start with

17. If air be taken from a vessel of volume A and condensed in a vessel of volume A' by a barrel of volume B of which the clearances C, C' at the ends are not traversed by the piston, prove that, neglecting the weights of the valves, the limiting ratio of the pressure in A to that in A' is

$$\frac{CC'}{(B-C)(B-C')}$$

18. The volume of the barrel of a condenser is v and a volume v' of it is below the piston when the latter is pushed down as far as it will go. If the valves open when the difference of pressure between the

two sides is p , and Π be the atmospheric pressure, prove that the maximum pressure that can be produced in the air in the receiver is

$$(\Pi - p) \frac{v}{v'} - p$$

19. In a Hawksbee's Air-pump, if A be the volume of the receiver and B that of the barrel, and if the piston fail to traverse a volume C at the bottom of the barrel, prove that the density after n strokes is

$$\frac{C}{B} + \left(1 - \frac{C}{B}\right) \left(\frac{A}{A+B}\right)^n$$

times that of the atmosphere

146. **Bramah's Press** This machine, used for exerting great pressures, has been referred to already in Art 12 Its essential form is there shewn

The annexed figure shews a section of the machine as actually used A small solid plunger is worked by the

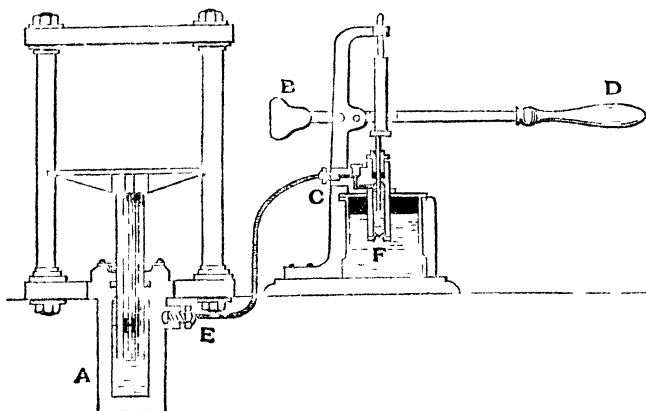

lever BD When this plunger moves upward, the valve at F rises, and liquid comes from the lower reservoir below F

When the plunger is moved downwards, this valve at F shuts, and the liquid is forced through a valve into CE and so into A

When the machine was first invented, great difficulty was found in making it watertight. The water forced its way out through the apertures through which the piston rods pass.

This was overcome by the use of a leather collar of the shape annexed.

This collar, saturated with oil to make it water-tight, fits with its concavity downwards in a groove in the side of the aperture. When water attempts to pass between the piston and the side of the aperture, it forces this leather collar tightly against the sides of the piston, and the greater the pressure of the water the more tightly does the collar fit. The water is thus, by its own pressure, prevented from squinting out.



147 Siphon The siphon is an instrument used for emptying vessels containing liquid. It consists of a bent tube ABC , one arm AB being longer than the other BC .

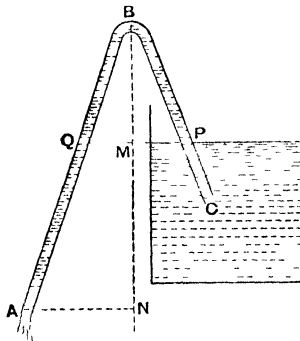

The siphon is filled with the liquid and, the ends A and C being stopped, is inverted, the end C of the shorter arm being placed under the level of the liquid in the vessel.

The instrument must be held so that the end A is below the level of the liquid in the vessel

If the ends A and C be now opened the liquid will begin to flow at A , and will continue to do so as long as the end A is below the surface of the liquid

To explain the action of the instrument Let B be the highest point of the siphon Draw a line BMN vertically downwards to meet the level of the surface of the liquid in M and a horizontal line through A in N

Let Q be the point in which the horizontal plane through P meets the limb BA

Consider the forces acting on the liquid in the siphon just before any motion takes place

The pressure at Q = pressure at P
 = pressure of the atmosphere.

Also pressure of the liquid at A
 = pressure at Q + wt of column NM .

Hence the pressure of the liquid at A is greater than atmospheric pressure, and therefore the liquid at A will flow out and the liquid in the limb BA will follow.

A partial vacuum would tend to be formed at B and, *provided the height MB be less than h , the height of the barometer formed by the liquid*, liquid would be forced from the vessel up the tube CB and a continuous flow would take place

The siphon is self-acting; the work is done by gravity as the liquid flows from the higher to the lower level

148. The two conditions which must hold so that the siphon can act are

(1) The end A (or the level of the liquid into which A dips) must be below the level of the liquid in the vessel

which is to be emptied. Otherwise the pressure of the liquid at A would be less, instead of greater, than atmospheric pressure, and the liquid would not flow out at A

(2) The height of the top of the siphon above the liquid at P must be less than the height of the corresponding liquid barometer. For otherwise the pressure of the atmosphere could not support a column so high as MB

In the case of water the greatest height of B above P is about 34 ft, for mercury it is about 30 ins

149. Ex *Water is flowing out of a vessel through a siphon. What would take place if the pressure of the atmosphere were removed and afterwards restored (1) when the lower end is immersed in water, (2) when it is not?*

In the first case the water in the two arms of the siphon would fall back into the two vessels and a vacuum would be left in the siphon. On the restoration of atmospheric pressure the siphon would resume its action

In the second case the two arms would empty themselves as before, on the restoration of the air the latter would now enter the open end of the siphon and fill it, consequently no action would now take place.

EXAMPLES XXVIII.

1. Over what height can water be carried by a siphon when the mercurial barometer stands at 30 inches (sp gr mercury = 13.6)?

2. What is the greatest height over which a liquid (of sp. gr. 1.5) can be carried by a siphon when the mercury stands at 30 inches, the sp. gr of mercury being 13.6?

3. An experimenter wishes to use a siphon to remove mercury from a vessel 3 feet deep. Why will he not be able to remove all of it by this means?

4. A cylindrical vessel, whose height is that of the water barometer, is three-quarters full of water and is fitted with an air-tight lid. If a siphon, whose highest point is in the surface of the lid and the end of whose longer arm is on a level with the bottom of the vessel, be inserted through an air-tight hole in the lid, prove that one-third of the water may be removed by the action of the siphon

5. What would happen if a small hole were made in (1) the shorter limb, (2) the longer limb of a siphon in action?

CHAPTER IX.

CENTRES OF PRESSURE

150 In the present chapter we return to the subject of the centres of pressure of certain areas immersed in liquid. Some results have been already stated in Art 43.

151 *Graphical construction for the centre of pressure of any plane area immersed in liquid*

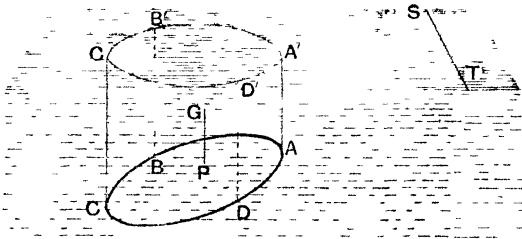

Let ABC be any plane area, through all the points A, B, C on its boundary draw vertical lines AA', BB', CC' to meet the surface of the liquid in points A', B', C' .

Consider the equilibrium of the cylinder thus cut off. The forces acting on its curved surface are all horizontal, and thus have no component in a vertical direction.

The forces on the plane base ABC are all perpendicular to the base, and thus by the laws of composition of parallel forces (*Statics*, Art 53) may be replaced by one single force, which is perpendicular to ABC and acts through its centre of pressure P

The vertical component of this single thrust, (since it is the resultant vertical thrust of Art 45), must balance the weight of the cylinder which acts through its centre of gravity G , and thus GP must be a straight line

Hence *the centre of pressure of any plane area is the point in which the area is met by the vertical line drawn through the centre of gravity of the cylinder formed by drawing straight lines through the boundary of the area to meet the surface of the liquid*

The above construction seems to fail when the plane of ABC is vertical

In any position of ABC , which is not vertical, let ST be the intersection of its plane with the surface of the liquid, and let the plane $STACB$ be turned round ST into any other position (including the vertical position) - Then the pressures at the different points are all altered proportionately, and they are all turned through the same angle

Hence by the principles of the Composition of Parallel Forces their centre is unaltered

*152. *Centre of pressure of a rectangular lamina immersed in homogeneous liquid with one side in the surface*

Let $ABCD$ be a rectangle inclined at a finite angle to the vertical plane through AB , which is in the surface of the liquid

Draw vertical lines through all the points on BC , CD , DA to meet the surface in BR , RQ , QA

* For proofs, by the use of the Integral Calculus, of this and the two following Articles see Pages 249—251

Then, by Art 151, the centre of pressure of the rectangle is the point P where the vertical line through

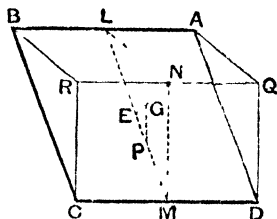

the centre of gravity G of the wedge $ABRQDC$ meets the rectangle

But if L , M , N be the middle points of AB , CD , RQ it is clear that the CG of the wedge coincides with the CG of the $\triangle LMN$.

Hence, bisecting LM in E , and taking $EG = \frac{1}{3}EN$, we have G the centre of gravity

If we draw GP vertically, we have, by similar triangles,

$$EP : EM :: EG : EN \quad 1 : 3.$$

$$\therefore EP = \frac{1}{3}EM = \frac{1}{3}LM,$$

and $LP = LE + EP = \frac{1}{2}LM + \frac{1}{3}LM = \frac{2}{3}LM$

Hence the centre of pressure lies on the middle line of the rectangle at a distance down equal to two-thirds of it

Cor. As in Art 151, if the rectangle be turned round AB till its plane is vertical, the position of its centre of pressure is unaltered

153. *Centre of pressure of a triangle immersed in homogeneous liquid with one side in the surface*

Let ABC be a triangle with its base BC in the surface

of the liquid, and its plane inclined at a finite angle to the vertical.

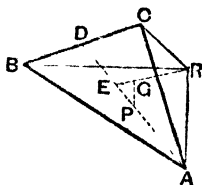

Draw AR vertically to meet the surface in R

Then (as in Art. 151) the required centre of pressure is the point in which the vertical through the centre of gravity of $ABCR$ meets the triangle ABC .

If D be the middle point of BC , $DE = \frac{1}{3}DA$, $EG = \frac{1}{4}ER$, and GP be drawn vertically to meet EA in P , then G is the centre of gravity of $ABCR$ (*Statics*, Art 107) and P is the required centre of pressure.

By similar triangles, $EP : EA :: EG : ER :: 1 : 4$

$$\therefore EP = \frac{1}{4}EA = \frac{1}{4} \times \frac{2}{3}DA = \frac{1}{6}DA.$$

$$\therefore DP = DE + EP = \frac{1}{3}DA + \frac{1}{6}DA = \frac{1}{2}DA.$$

Hence the centre of pressure bisects the median DA

Cor. If a be the vertical depth of A below BC , Δ be the area of the triangle, and w the specific weight of the liquid, the whole thrust acts at P , and

$$= w \cdot \Delta \times \text{depth of the centre of gravity of the triangle}$$

$$= w \cdot \Delta \cdot \frac{a}{3}$$

The thrust on the triangle is thus equivalent to two equal forces, each $\frac{1}{2}w \cdot \Delta \cdot a$ acting at the middle points of AB , AC .

Alter Conceive the triangle to be divided into a very large number of narrow strips of equal breadth by straight lines parallel to the base BC .

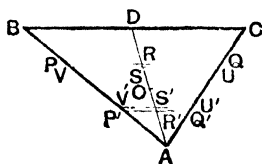

Let $PQUV$, $P'Q'U'V'$ be two such strips equidistant respectively from BC and A , so that $DR = AK'$, and $DR' = AR$

If the distances RS and $K'S'$ are equal, the areas are proportional to PQ and $P'Q'$

Also the pressure at each point of $PQUV$ is proportional to RD ultimately.

So the pressure at each point of $P'Q'U'V'$ is proportional to $R'D$ ultimately

$$\begin{aligned} \frac{\text{whole pressure on } PU}{\text{whole pressure on } P'U'} &= \frac{PQ}{P'Q'} \frac{DR}{DR'} = \frac{QR}{Q'R'} \frac{AR'}{AR} \\ &= \frac{AR}{AR'} \frac{AR'}{AR} = 1. \end{aligned}$$

Hence the pressures on PU , $P'U'$ are equal, and they act at equal distances from O the middle point of AD , hence their resultant is at O

Similarly for any other such pair of strips

Thus the centre of pressure of the whole triangle is at O , the middle point of the median DA .

154. Centre of pressure of a triangle immersed in a liquid with a vertex in the surface and the opposite side horizontal

Let ABC be a triangle with the vertex A in the surface and the side BC horizontal

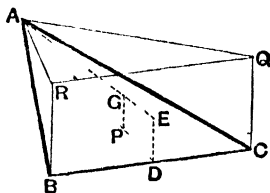

Through B, C draw vertical lines to meet the surface in R, Q .

Then, as in Art. 151, the required centre of pressure is the point in which the vertical through the centre of gravity of $ABCQR$ meets the triangle ABC

Since BC is horizontal, it is equal to RQ

Hence if E be the centre of the rectangle $BCQR$, the centre of gravity of $ABCQR$ is the point G where $AG = \frac{3}{4}AE$.

Draw ED perpendicular to BC , then ED bisects BC

Draw GP vertically to meet AD in P .

Then P is the required centre of pressure.

By similar triangles, $AP : AD :: AG : AE . 3 : 4$

$$\therefore AP = \frac{3}{4}AD$$

Thus the required centre of pressure divides the median in the ratio 3 . 1.

155. We shall now give another method of obtaining the results of the previous articles, it consists of a division of the area into very thin strips, the thrust on each of which is known and also its centre of pressure, and then of an application of the formulæ of *Statics*, Art 111.

156. Rectangle.

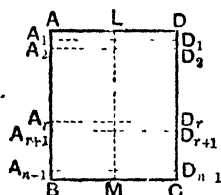

Let $AD = a$ and $AB = b$.

Divide the side AB into a large number, n , of equal parts so that each of the distances

$$AA_1, A_1A_2, \quad A_rA_{r+1}, \quad A_{n-1}B$$

is equal to the small quantity $\frac{b}{n}$.

Through the points A_1, A_2, \dots draw lines parallel to AD , thus dividing the rectangle into a series of equal very thin strips

Each such strip may thus be considered to have the pressure at each point of it the same, and thus the whole pressure on it acts at its middle point which is on the straight line LM , which joins the middle points of AD and BC

Now the strips A_rD_{r+1} being *very* thin, its centre of pressure and centre of gravity will coincide very approxi-

mately with the middle point of A, D_r , and thus they both will be at a distance $\frac{1}{n}b$ from L .

Hence, since the thrust on each strip is equal to its area \times depth of its CG,

the thrusts on the strips $A_1D_1, A_2D_2, \dots, A_{n-1}C$ are clearly

$$\frac{ab}{n} \times \frac{b}{n}, \quad \frac{ab}{n} \times \frac{2b}{n}, \quad \frac{ab}{n} \times \frac{3b}{n}, \quad \dots, \quad \frac{ab}{n} \times \frac{(n-1)b}{n},$$

and they act at distances from L equal to

$$\frac{b}{n}, \quad \frac{2b}{n}, \quad \frac{3b}{n}, \quad \dots$$

Hence, if \bar{x} be the distance from L of the centre of pressure, we have [Statics, Art. 111]

$$\begin{aligned} \bar{x} &= \frac{\frac{ab}{n} \times \left(\frac{b}{n}\right)^2 + \frac{ab}{n} \times \left(\frac{2b}{n}\right)^2 + \dots + \frac{ab}{n} \times \left(\frac{(n-1)b}{n}\right)^2}{\frac{ab}{n} \times \frac{b}{n} + \frac{ab}{n} \times \frac{2b}{n} + \dots + \frac{ab}{n} \times \frac{(n-1)b}{n}} \\ &= \frac{b}{n} \frac{1^2 + 2^2 + 3^2 + \dots + (n-1)^2}{1 + 2 + 3 + \dots + (n-1)} = \frac{b}{n} \frac{(n-1) \cdot n \cdot (2n-1)}{6} \\ &= \frac{b}{3} \frac{2n-1}{n} = \frac{2b}{3} \left[1 - \frac{1}{2n}\right] \end{aligned}$$

Now let n be made indefinitely great in which case $\frac{1}{n}$ is ultimately zero

$$\therefore \bar{x} = \frac{2b}{3}, \text{ as before } [\text{Art. 152}]$$

Cor. The proofs both of this Article and of Art 152 hold if the rectangle be replaced by a parallelogram with one side in the surface

157. *Triangle with its vertex in the surface and the opposite side horizontal*

Let $AD = d$, D being the middle point of the base BC .

Let the triangle ABC be divided into a very large number, n , of very thin strips by straight lines B_1C_1 ,

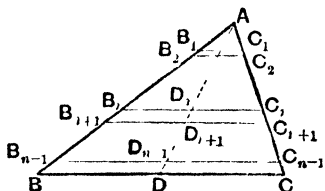

B_2C_2 , B_rC_r , $B_{n-1}C_{n-1}$, all parallel to BC , and which divide the distance AD into distances $\frac{d}{n}$ at the points

$$D_1, D_2, \dots, D_{n-1}.$$

By similar triangles $B_rC_r = \frac{AD_r}{AD} \times a$.

Hence the area of the very thin strip $B_rC_rC_{r+1}B_{r+1}$

$$\propto AD_r, \text{ i.e. } \propto \frac{r}{n} d.$$

The depth of its c.g. $\propto AD_r$, i.e. $\propto \frac{r}{n} d$ [For the c.g. is the middle point of D, D_{r+1} and hence coincides very nearly with D_r] Hence the total pressure on $B_rC_{r+1} \propto \frac{r^2}{n^2} d^2$

Also the centre of pressure of this strip coincides very nearly with D_r , and thus its distance from A is very nearly $\frac{r}{n} d$.

Hence, by the rule for the centre of any system of parallel forces, we have

$$\begin{aligned} \bar{x} &= \frac{\Sigma (\text{pressure on each element} \times \text{dist of its c p})}{\Sigma (\text{pressure on each element})} \\ &= \frac{\Sigma \left(\frac{r^2}{n^2} d^2 \times \frac{r}{n} d \right)}{\Sigma \left(\frac{r^2}{n^2} d^2 \right)}, \text{ for all values of } r \text{ from } 1 \text{ to } n-1, \\ &= \frac{d^3 [1^3 + 2^3 + 3^3 + \dots + (n-1)^3]}{\frac{d}{n^2} [1^2 + 2^2 + \dots + (n-1)^2]} \\ &= \frac{d}{n} \frac{\left\{ \frac{(n-1)}{2} \cdot n \right\}^2}{(n-1) n (2n-1)} - \frac{6}{4} \frac{n-1}{2n-1} d \\ &= \frac{3}{4} \frac{1 - \frac{1}{n}}{1 - \frac{1}{2n}} d. \end{aligned}$$

Now let n become infinitely great, so that $\frac{1}{n}$ becomes zero

Thus
$$\bar{x} = \frac{3d}{4} = \frac{3}{4} AD$$

EXAMPLES. XXIX.

1. A triangle is wholly immersed in a liquid with its base in the surface. Shew that a horizontal straight line drawn through the centre of pressure of the triangle divides it into two parts the thrusts on which are equal

2. A cubical box filled with water is closed by a lid without weight which can turn freely about one edge of the box, and a string is tied symmetrically about the box in a plane which bisects this

edge; if the lid be in a vertical plane with this edge uppermost, prove that the tension of the string is equal to one-third of the weight of the water

3. A rectangular box of thin sheet metal in the shape of half a cube has one edge hinged horizontally on a vertical wall, the square face of the box next the wall being removed. Find the weight of the metal per square foot so that, if the box be filled with water, none shall leak out, the length of the edge of the box being a feet.

4. Shew that the depth below the surface of a liquid of the centre of pressure of a rectangle, two of whose sides are horizontal and at depths a and b , is $\frac{2}{3} \frac{a^2 + ab + b^2}{a + b}$.

[Produce the vertical sides of the rectangle to meet the surface of the liquid, then the thrust on the given rectangle is equal to the difference of the thrusts on two rectangles, each of which has a side in the surface, also these thrusts and their points of application are known by Arts. 89 and 156, then proceed as in *Statics*, Art 116.]

5. The lengths of the two parallel sides of a trapezium are a and b and the distance between them is h , if the trapezium be immersed in water with its plane vertical and the side a in the surface, prove that the centre of pressure will be at a depth $\frac{a + 3b}{a + 2b} \times \frac{h}{2}$ below the surface

6. A lamina in the shape of a quadrilateral $ABCD$ has its side CD in the surface of a liquid and the sides AD, BC vertical and equal to α, μ respectively. Shew that the depth of its centre of pressure is

$$\frac{1}{2} \frac{(\alpha^2 + \beta^2)(\alpha + \beta)}{\alpha^2 + \alpha\beta + \beta^2}.$$

7. A cubical box is filled with water and has a closely fitting heavy lid fixed by smooth hinges to one edge, compare the tangents of the angles through which the box must be tilted about the several edges of its base so that the water may just begin to escape.

8. Find the centre of pressure of the case of Art 154 by considering it as the difference between the cases of Arts 152 and 153

158. A plane area is immersed in a homogeneous liquid, and the depths of its centres of gravity and pressure are respectively a and b , if the whole area be now lowered (without any rotation), to find the new position of the centre of pressure.

Let G be the centre of gravity, and P the centre of pressure, of the area in the first position when BC is the surface of the liquid

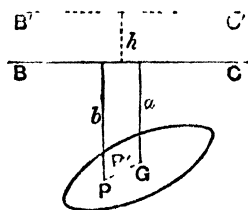

Let the area be depressed through a distance h ; or, what is equivalent, let a depth h of liquid be superimposed on BC .

In the original position the thrust on the area was equal to Aaw acting at P (Art 39), where A is the given area and w the specific weight of the liquid

The effect of putting on the additional liquid is to increase the pressure on each element of A by the amount due to the depth h , that is, by wh per unit of area

The resultant of all these additional pressures is therefore Awh acting at G

The point P' at which acts the resultant of Aaw at P , and Awh at G , is clearly the new centre of pressure.

By the rule for compounding parallel forces, it follows that P' lies on PG , and divides it so that

$$PP' \cdot P'G : Awh :: Aaw : Awh$$

$$\therefore h : a.$$

159 From the preceding article, by taking moments about $B'C'$, we have

$$\begin{aligned} \text{depth of } P' \text{ below } B'C' &= \frac{\Delta aw \times (b+h) + \Delta hw \times (a+h)}{\Delta aw + \Delta hw} \\ &= \frac{h^2 + 2ah + ab}{h+a} \end{aligned}$$

Hence the depth below the new surface of the new centre of pressure

- depth below the original surface of the original centre of pressure

$$= \frac{h^2 + 2ah + ab}{h+a} - b = h \times \frac{2a - b + h}{a+h},$$

so that the depth of the centre of pressure *below the surface of the water* is greater by this amount.

Also depth of P' below $B'C'$

- depth of P „ „

$$= \frac{h^2 + 2ah + ab}{h+a} - (b+h) = -h \frac{b-a}{h+a},$$

and this quantity is always negative

Hence *in the area itself* the centre of pressure is *raised* through the distance $h \frac{b-a}{h+a}$

Also the vertical distance between the centre of gravity and the centre of pressure in the second position

$$= \frac{h^2 + 2ah + ab}{h+a} - (a+h) = \frac{ab - a^2}{h+a},$$

and hence \propto inversely as $h+a$,

i.e. \propto inversely as the depth of the CG below the surface.

It follows that, the greater the depth, the more nearly does the centre of pressure approach to the centre of gravity, and hence that at an infinite depth the two centres coincide

160. If the position of the centre of pressure of an area, when the atmospheric pressure is neglected, be known, its position may now be found when this pressure is taken into account

For if h be the height of a barometer filled with the same liquid as that in which the area is inserted, the atmospheric pressure is equivalent to superimposing a depth h of the liquid, as in Fig Art 158

161 Ex Find what effect an atmospheric pressure, equal to a water-barometric height h , has on the position of the centre of pressure in the case of Art 152.

When there is no air-pressure, the thrust on the rectangle is $ab \times \frac{b}{2} \times w$ and acts at P , where $LP = \frac{2b}{3}$.

The atmospheric pressure is equivalent to $ab \times h \times w$, and acts at E , where $LE = \frac{b}{2}$.

Taking moments about L , we see that the distance from L of the new centre of pressure

$$\begin{aligned} & ab \times \frac{b}{2} \times w \times \frac{2b}{3} + ab \times hw \times \frac{b}{2} \\ &= \frac{ab \times \frac{bw}{2} + ab \times hw}{\frac{2b^2}{3} + hb} = \frac{b}{3} \frac{2b + 3h}{b + 2h}. \end{aligned}$$

EXAMPLES. XXX.

1. A square lamina is just immersed vertically in water, and is then lowered through a depth b , if a be the length of the edge of the square, prove that the distance of the centre of pressure from the centre of the square is $\frac{a^2}{6a + 12b}$

2. A triangle, of base a and altitude h , is placed in water with its plane vertical and the side a horizontal and at a depth k below the surface of the water, find the depth of the centre of pressure, the vertex being the highest point of the triangle.

3. If the triangle in the previous question be placed with the vertex at a depth h and the opposite side a horizontal, the plane of the triangle being vertical, find the depth of the centre of pressure, the vertex being the lowest point of the triangle.

4. An equilateral triangle, each of whose sides is $6\sqrt{3}$ feet long, is immersed vertically in water with its side in the surface which is open to the air. If the water barometer stand at 34 feet, find the depth of the centre of pressure of the triangle.

5. A triangle has its base in the surface of a liquid and its vertex downwards, if the atmospheric pressure be equivalent to a height h of water, prove that the centre of pressure will be higher by a distance $\frac{1}{2} \frac{h\delta}{h+\delta}$ than it is when the atmospheric pressure is neglected, where δ is the distance of the centre of gravity of the triangle below the surface of the water.

6. If the triangle in the previous question has its vertex in the surface and base horizontal, find the corresponding distance.

7. If the position of the centre of pressure of a plane area be known when the atmospheric pressure is neglected, prove that its position when the atmospheric pressure is included may be found by the following rule, the depths of the centres of pressure and gravity below the free surface in the second case are in the same ratio as the depths of the corresponding points in the first case, each increased by the height of the water barometer, also the two centres of pressure lie on a straight line passing through the centre of gravity.

8. A plane area is completely immersed in water its plane being vertical, it is made to descend in a vertical plane without any rotation and with uniform velocity, prove that the centre of pressure approaches the horizontal through its centre of mass with a velocity which is inversely proportional to the square of the depth of the centre of mass.

162. *The centre of pressure of any triangle immersed in homogeneous liquid coincides with the centre of parallel forces acting at the middle points of the sides and of magnitudes proportional to the depths of their middle points*

Let ABC be a triangle with its vertex A in the surface of the liquid, and its base BC in any position, and let BC be produced to meet the surface in K . Let D, E, F be the

middle points of the sides of the triangle, and E' , F' the middle points of CK , BK .

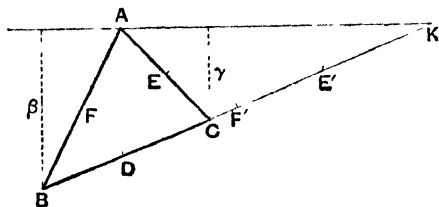

Let $AK = k$, and let β , γ be the depths of the points B and C below AK . The area of the triangle $ABK = \frac{1}{2} \beta k$

Then, by Art 153 Cor., the whole thrust on ABK is equivalent to forces $\frac{1}{12} \omega k \beta^2$ at F and F' , i.e. to forces $\lambda \beta^2$ at A and K and $2\lambda \beta^2$ at B , where $\lambda = \frac{k \omega}{24}$

So the thrust on the triangle ACK is equivalent to forces $\lambda \gamma^2$ at A and K and $2\lambda \gamma^2$ at C

Now the whole thrust on ABC is equal to the difference between the thrusts on ABK , ACK , and is thus equivalent to forces

$$\lambda(\beta^2 - \gamma^2) \text{ at } A, \quad 2\lambda\beta^2 \text{ at } B, \quad -2\lambda\gamma^2 \text{ at } C$$

and $\lambda(\beta^2 - \gamma^2) \text{ at } K$ (1)

Now since $BK = CK \cdot \beta / \gamma$,

a force $(\beta - \gamma)$ at K is equivalent to $-\gamma$ at B and β at C , [Statics, Art 53], and hence $\lambda(\beta^2 - \gamma^2)$ at K

$$\equiv -\lambda\gamma(\beta + \gamma) \text{ at } B \text{ and } \lambda\beta(\beta + \gamma) \text{ at } C$$

Hence the forces (1) are equivalent to,

at A , $\lambda(\beta^2 - \gamma^2)$,

at B , $2\lambda\beta^2 - \lambda\gamma(\beta + \gamma)$, i.e. $\lambda(\beta - \gamma)(2\beta + \gamma)$,

at C , $-2\lambda\gamma^2 + \lambda\beta(\beta + \gamma)$, i.e. $\lambda(\beta - \gamma)(\beta + 2\gamma)$ (2).

Now the area Δ of the triangle $ABC = \frac{k\beta}{2} - \frac{k\gamma}{2}$, so that

$$\lambda(\beta - \gamma) = \frac{k\omega}{24}(\beta - \gamma) = \frac{\omega\Delta}{12}$$

Hence the forces (2) are equivalent to

$\frac{\omega\Delta}{12}(\beta + \gamma)$ at A , $\frac{\omega\Delta}{12}(2\beta + \gamma)$ at B , and $\frac{\omega\Delta}{12}(\beta + 2\gamma)$ at C ,

or to $\frac{\omega\Delta}{3} \cdot \frac{\beta}{2}$ at F , $\frac{\omega\Delta}{3} \cdot \frac{\gamma}{2}$ at E , and $\frac{\omega\Delta}{3} \cdot \frac{\beta + \gamma}{2}$ at D ,

or to forces at D, E, F proportional to their depths

Next let the triangle be depressed through a distance a' , and let β', γ' be the new depths of B and C .

Then $\beta' = a' + \beta$, and $\gamma' = a' + \gamma$

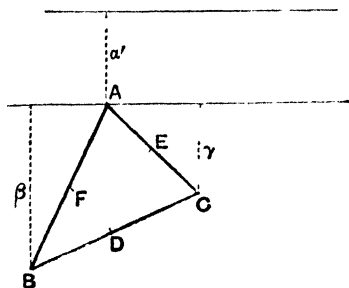

The effect of this depression is to cause an additional thrust $\omega \cdot \Delta \cdot a'$ at the c.g. of ABC ,

that is, $\frac{\omega\Delta}{3} a'$ at each of D, E , and F . [*Statics*, Art 104

The thrust on the triangle is then equivalent to

$$\frac{w\Delta}{3} \left(\frac{\beta + \gamma}{2} + a' \right), \quad \text{ve } \frac{w\Delta}{3} \frac{\beta' + \gamma'}{2} \quad \text{at } D,$$

$$\frac{w\Delta}{3} \left(\frac{\gamma}{2} + a' \right), \quad \text{ve } \frac{w\Delta}{3} \frac{\gamma' + a'}{2} \quad \text{at } E,$$

and $\frac{w\Delta}{3} \left(\frac{\beta}{2} + a' \right), \quad \text{ve } \frac{w\Delta}{3} \frac{a' + \beta'}{2} \quad \text{at } F$

Hence with the triangle in any position the centre of pressure coincides with the centre of forces acting at the middle points of its sides of magnitudes proportional to the depths of these sides

Cor By the formula for the centre of parallel forces [*Statics* Art 111] the depth of the centre of pressure

$$\begin{aligned} & \frac{w\Delta}{3} \left(\frac{\beta' + \gamma'}{2} \right)^2 + \frac{w\Delta}{3} \cdot \left(\frac{\gamma' + a'}{2} \right)^2 + \frac{w\Delta}{3} \left(\frac{a' + \beta'}{2} \right)^2 \\ = & \frac{\frac{w\Delta}{3} \frac{\beta' + \gamma'}{2} + \frac{w\Delta}{3} \frac{\gamma' + a'}{2} + \frac{w\Delta}{3} \frac{a' + \beta'}{2}}{\frac{(\beta' + \gamma')^2 + (\gamma' + a')^2 + (a' + \beta')^2}{4(a' + \beta' + \gamma')}} \\ = & \frac{a'^2 + \beta'^2 + \gamma'^2 + \beta'\gamma' + \gamma'a' + a'\beta'}{2(a' + \beta' + \gamma')} \end{aligned}$$

163 By the use of the preceding theorem the centres of pressure of many figures may be obtained by dividing them up into triangles

Ex A regular hexagon, $ABCDEF$, is immersed in water with one side AB in the surface, shew that the depth of its centre of pressure is to that of its centre of gravity as 23 to 18

Let O be its centre and A_1, B_1, C_1, F_1 be the middle points of OA, OB, OF and P, Q, R, S, T, U the middle points of AB, BC, CD, DE, EF, FA

Let $PO = a$.

Then the depths of Q, B_1, A_1, U are each $\frac{\alpha}{2}$,

those of C_1, F_1 are each α ,

those of R, D_1, E_1, T are each $\frac{3\alpha}{2}$,

and that of S is 2α

The areas of the six triangles into which the hexagon is divided are all equal, and we thus have to place at the middle points of each side of each triangle a force proportional to the depth of the point

We thus have one force $\frac{w\Delta}{3}$ O at depth O ,

six forces $\frac{w\Delta}{3}$ $\frac{\alpha}{2}$, " $\frac{\alpha}{2}$,

four forces $\frac{w\Delta}{3}$ α " " α ,

six forces $\frac{w\Delta}{3}$ $\frac{3\alpha}{2}$ " " $\frac{3\alpha}{2}$,

and one force $\frac{w\Delta}{3}$ 2α " " 2α

Hence (*Statics*, Art 111) the depth of the centre of pressure

$$\begin{aligned} &= \frac{\frac{w\Delta}{3} \left\{ 6 \left(\frac{\alpha}{2} \right)^2 + 4\alpha^2 + 6 \left(\frac{3\alpha}{2} \right)^2 + (2\alpha)^2 \right\}}{\frac{w\Delta}{3} \left\{ 6 \frac{\alpha}{2} + 4 \alpha + 6 \frac{3\alpha}{2} + 2\alpha \right\}} \\ &= \alpha \times \frac{\frac{6}{4} + 4 + \frac{54}{4} + 4}{3 + 4 + 9 + 2} = \frac{23}{18} \alpha \end{aligned}$$

EXAMPLES XXXI.

1. Shew that the depth of the centre of pressure of a triangular lamina, the depths of whose angular points are α, β , and γ , exceeds the depth of the centre of gravity by $\frac{\alpha^2 + \beta^2 + \gamma^2 - \beta\gamma - \gamma\alpha - \alpha\beta}{6(\alpha + \beta + \gamma)}$

Shew also that it is the centre of parallel forces at the angular points proportional respectively to $2\alpha + \beta + \gamma$, $\alpha + 2\beta + \gamma$, and $\alpha + \beta + 2\gamma$

2. A triangle ABC has the vertex A in the surface of water and its angular points B, C at depths x and y respectively, the height of the water barometer being h , find the depth of the centre of pressure of the triangle

3. A rhombus is immersed in a liquid with a vertex in the surface and the diagonal through that vertex vertical, prove that the centre of pressure divides the diagonal in the ratio 7 : 5

4. A square is immersed, with its diagonal vertical, and its lowest point as deep again as its highest point. Find the depth of its centre of pressure.

5. The depth of the centre of pressure of a rhombus totally immersed, with one diagonal vertical and its centre at a depth h , is $h + \frac{a^2}{24h}$, where a is the length of the vertical diagonal

6. A parallelogram has its corners at depths h_1, h_2, h_3, h_4 below the surface of a liquid, and its centre at a depth h , shew that the depth of its centre of pressure is $\frac{h_1^2 + h_2^2 + h_3^2 + h_4^2 + 8h^2}{12h}$

7. A regular hexagon is immersed in water with one side in the surface, find the depth of the centre of pressure of the upper half

8. Shew that the centre of pressure of a rhombus immersed in two liquids, which do not mix, with a vertex in the upper surface and a diagonal in the common surface, divides the other diagonal in the ratio 5 : 3, if the density of the lower liquid be three times that of the upper

**9. A rectangle is immersed in n liquids of densities $\rho, 2\rho, 3\rho, \dots, n\rho$, which do not mix, the top of the rectangle is in the surface of the first liquid, and the area immersed in each is the same, prove that the depth of the centre of pressure of the rectangle is $\frac{3n+1}{2n+1} \cdot \frac{h}{2}$, where h is the depth of the lower side

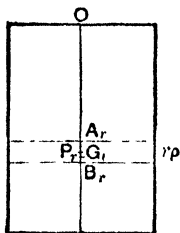

Let G_r be the centre of gravity of the area in the r th liquid, and P_r the point that would be its centre of pressure if there were no liquid above it

Then, if O be the middle point of the highest edge of the rect angle,

$$OA_r = (r-1) \frac{h}{n}, \quad A_r G_r = \frac{h}{2n}, \quad \text{and} \quad A_r P_r = \frac{2}{3} \frac{h}{n}$$

As in Art 42, Ex 3, we may replace the liquid above A_r by a thickness x of density $r\rho$, where

$$x \times r\rho = \frac{h}{n} \rho [1 + 2 + \dots + (r-1)] = \frac{h}{n} \frac{(r-1)r}{2} \rho,$$

$$x = (r-1) \frac{h}{2n}$$

Hence, by the rule of Art 158, the thrust on the portion in the liquid $r\rho$ is equivalent to

$$A \ r\rho \times x \text{ at } G_r, \text{ and to } A \ r\rho \times \frac{h}{2n} \text{ at } P_r,$$

where A is the area of this portion

Hence, by the rule for the centre of parallel forces, we have

$$\begin{aligned} \bar{x} &= \frac{\sum_1^n \left(A \ r\rho \ x \times OG_r + A \ r\rho \times \frac{h}{2n} \times OP_r \right)}{\sum_1^n \left(A \ r\rho \ x + A \ r\rho \ \frac{h}{2n} \right)} \\ &= \frac{\sum_{r=1}^{r-n} \left[r \ (r-1) \ \frac{h}{2n} \left\{ (r-1) \frac{h}{n} + \frac{h}{2n} \right\} + r \ \frac{h}{2n} \left\{ (r-1) \frac{h}{n} + \frac{2}{3} \frac{h}{n} \right\} \right]}{\sum_{r=1}^{r-n} \left[r \cdot (r-1) \ \frac{h}{2n} + r \ \frac{h}{2n} \right]} \\ &= \frac{h}{2n} \times \frac{\sum_1^n [r(r-1)(2r-1) + r(2r-2)]}{\sum_1^n [r^2]} \\ &= \frac{h}{6n} \times \frac{\sum_1^n [6r^3 - 3r^2 + r]}{\sum_1^n r^2} \\ &= \frac{h}{6n} \times \frac{6 \times \left[\frac{n(n+1)}{2} \right]^2 - 3 \times \frac{n(n+1)(2n+1)}{6} + \frac{n(n+1)}{2}}{\frac{n(n+1)(2n+1)}{6}} \\ &= \frac{h}{6n} \times 3 \times \frac{n^2(n+1)(3n+1)}{n(n+1)(2n+1)} \\ &= \frac{h}{2} \frac{3n+1}{2n+1}. \end{aligned}$$

10. A plane quadrilateral $ABCD$ is entirely immersed in water with the side AB in the surface. If the depths of C and D below the surface are γ and δ respectively, and that of the $C.G.$ is h , prove that the depth of the centre of pressure is $\frac{\gamma+\delta}{2} - \frac{1}{6} \frac{\gamma\delta}{h}$.

Shew that a quadrilateral so immersed cannot have the depths of its centres of gravity and pressure in the ratio of 2 : 3.

**11. If a, β, γ, δ be the depths of the four corners of a quadrilateral area immersed in water, prove that the depth of the centre of pressure is

$$\frac{a+\beta+\gamma+\delta}{2} - \frac{\beta\gamma+\gamma\alpha+a\beta+a\delta+\beta\delta+\gamma\delta}{6h},$$

where h is the depth of the centre of gravity.

Let $ABCD$ be the quadrilateral, the depths of A, B, C, D being a, β, γ, δ respectively.

Let x, y be the areas of the triangles ABD, BCD . Then since the depth of the centres of gravity of ABD, BCD are

$$\frac{a+\beta+\delta}{3} \text{ and } \frac{\beta+\gamma+\delta}{3},$$

$$\text{we have } h = \frac{1}{3} \frac{x \times (a+\beta+\delta) + y \times (\beta+\gamma+\delta)}{x+y} \quad (1)$$

$$\therefore \frac{x}{\beta+\gamma+\delta-3h} = \frac{y}{a+\beta+\delta-3h} \quad (2)$$

Now the thrusts on the triangles ABD, BCD are

$$x \times \frac{a+\beta+\delta}{3} \times w \text{ and } y \times \frac{\beta+\gamma+\delta}{3} \times w,$$

and the depths of their centres of pressure are, by Art. 162, Cor.

$$\frac{a^2+\beta^2+\delta^2+a\beta+a\delta+\beta\delta}{2(a+\beta+\delta)} \text{ and } \frac{\beta^2+\gamma^2+\delta^2+\beta\gamma+\gamma\delta+\delta\beta}{2(\beta+\gamma+\delta)}$$

Hence, if \bar{x} be the depth of the required centre of pressure,

$$\begin{aligned} \bar{x} &= \left[xw \frac{a+\beta+\delta}{3} + yw \frac{\beta+\gamma+\delta}{3} \right] \\ &= \frac{w}{6} [x(a^2+\beta^2+\delta^2+a\beta+a\delta+\beta\delta) + y(\beta^2+\gamma^2+\delta^2+\beta\gamma+\gamma\delta+\delta\beta)] \end{aligned}$$

i.e., by equation (1),

$$\begin{aligned} \bar{x} &= \frac{1}{6} \times \frac{x(a^2+\beta^2+\delta^2+a\beta+a\delta+\beta\delta) + y(\beta^2+\gamma^2+\delta^2+\beta\gamma+\gamma\delta+\delta\beta)}{(x+y)h} \\ &= \frac{1}{6} \times \frac{(\beta+\gamma+\delta-3h)(a^2+\beta^2+\delta^2+a\beta+a\delta+\beta\delta) - (a+\beta+\delta-3h)(\beta^2+\gamma^2+\delta^2+\beta\gamma+\gamma\delta+\delta\beta)}{h(\gamma-a)} \end{aligned}$$

$$= \frac{1}{6} \times \frac{(a - \gamma) [a\beta + a\gamma + a\delta + \beta\gamma + \beta\delta + \gamma\delta] + 3h(\gamma - a)(a + \beta + \gamma + \delta)}{h(\gamma - a)},$$

on reduction,

$$= \frac{a + \beta + \gamma + \delta}{2} - \frac{a\beta + a\gamma + a\delta + \beta\gamma + \beta\delta + \gamma\delta}{6h}.$$

12. A square, whose side is $2a$, is immersed in water, its plane but none of its sides being vertical. Show that the centre of pressure lies vertically below the centre of the square at a distance from it equal to $\frac{a^2}{3h}$, where h is the depth of the centre of the square below the effective surface.

13. A square is partly immersed in a liquid so that its plane is vertical and its centre in the surface. Show that the centre of pressure of the immersed part is always vertically beneath the centre of the square.

CHAPTER X.

ROTATING LIQUIDS

164 A SURFACE of equal pressure is a surface such that at all points of it the pressure is the same

The resultant thrust at any point of a fluid at rest, or of a perfect fluid in motion, is perpendicular to the surface of equal pressure passing through the point

Consider any point P in the fluid and take an elementary length PQ lying in the surface of the surface of equal pressure passing through P

Consider an indefinitely thin cylinder, whose axis is PQ

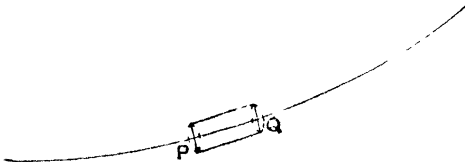

The pressure on the ends P and Q are equal, since the areas of the ends are the same, and P and Q lie in a surface of equal pressure

Hence the resultant thrust on this cylinder is perpendicular to PQ .

Similarly it is perpendicular to any other straight line drawn through P in the surface of equal pressure.

Hence it is perpendicular to this surface.

165 *If a vessel, and the liquid contained in it, rotate uniformly about a vertical axis, the free surface of the liquid is a paraboloid, i.e. the surface formed by the revolution of a parabola about its axis*

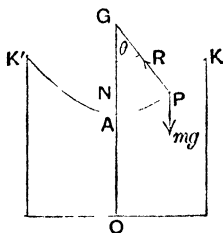

Let the surface of liquid take the shape of the surface generated by the revolution of the curve APK about OA the axis of rotation

Let ω be the uniform angular velocity

Consider any small element of the liquid at any point P of the surface of the liquid, and draw a normal PG to the curve. Then the thrust, R , of the liquid on this element is in the direction PG .

[For the surface generated by APK is in contact with the air whose pressure is constant. Hence APK generates the surface of equal pressure through P and therefore, by the last article, the direction of the resultant thrust is perpendicular to this surface.]

The only other force acting on this element is a force mg vertically downwards, where m is the mass of the element

Draw PN perpendicular to the axis AG .

Then P describes a circle of radius NP with angular velocity ω .

Hence, by *Dynamics*, Art 135, there must be a force acting on it along PN equal to $m\omega^2 PN$.

This force must be the resultant of the two forces R and mg .

Resolving vertically and horizontally, we thus have

$$R \cos \theta - mg = 0 \quad . \quad . \quad . \quad (1),$$

and
$$R \sin \theta = m\omega^2 \cdot PN \dots \dots (2),$$

where θ is the angle NGP

$$\dots \tan \theta = \frac{\omega^2 PN}{g},$$

i.e.
$$\frac{g}{\omega^2} = PN \cot \theta = NG.$$

Hence the curve AP is such that the sub normal NG is constant. Now this is a property of the parabola, in which the sub normal is equal to the semi-latus-rectum

[Also it could be shewn, but the proof would require the Integral Calculus, that no other curve possesses this property]

Hence the curve AP is a parabola, of latus-rectum $\frac{2g}{\omega^2}$, whose axis is the axis of rotation.

The surface of the water, which by symmetry is the surface formed by the rotation of the curve AP about the vertical, is thus a paraboloid

Cor. From the fundamental property of the parabola, we have

$$PN^2 = \text{latus-rect.} \times AN = \frac{2g}{\omega^2} AN,$$

and this relation is true for all points P lying on the surface

166. To find the pressure at any point of the rotating liquid.

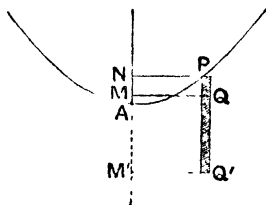

Let Q be any point in the liquid. Draw a straight line QP vertically upward to meet the surface in P . About PQ as axis describe a very thin circular cylinder in the liquid of small sectional area a . Draw PN , QM perpendicular to the axis AMN of rotation.

If p be the pressure of the liquid at Q , the vertical forces acting on the small cylinder PQ are $p a$ vertically upwards at Q , and its weight $g\rho a \cdot QP$ vertically downwards, where ρ is the density of the liquid.

Since the motion is one of steady revolution, the cylinder QP has no vertical acceleration. Hence the vertical forces on it vanish, and thus

$$p a - g\rho a \cdot QP = 0.$$

$$\begin{aligned} \therefore p &= g\rho \cdot QP = g\rho \cdot MN \\ &= g\rho (AN - AM). \end{aligned}$$

$$\text{But, by Art 165, } PN^2 = \frac{2g}{\omega^2} AN.$$

$$\begin{aligned} \therefore p &= g\rho \left(\frac{\omega^2}{2g} PN^2 - AM \right) \\ &= \rho \left(\frac{1}{2} \omega^2 \cdot QM^2 - g \cdot AM \right) \end{aligned}$$

If Q be below A , as at Q' , then

$$M'N = M'A + AN,$$

and the pressure = $\rho \left(\frac{1}{2} \omega^2 QM^2 + g AM' \right)$

Cor. 1. In the previous article we have neglected the pressure of the air. If this be taken into consideration, and be denoted by Π , we have an additional vertical pressure Πa at P , and the value of p in the preceding article must be increased by Π .

Cor. 2. If through each point on the curve AP we draw lines vertically downwards and equal to PQ , their ends will all lie on a curve which is of the same size and shape as AP . Also the pressures at the points thus obtained will be the same. Hence

The surfaces of equal pressure are equal parabolas

167 **Ex 1** A circular cylinder closed at the top is very nearly filled with liquid, and it and the liquid rotate with uniform angular velocity ω about the axis which is vertical, and the total thrusts of the liquid on the bottom and top of the cylinder

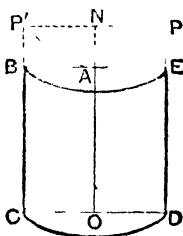

Let $BCDE$ be the section of the cylinder by a plane through its axis AO

Let the height $AO = h$, and the radius OD of the base = r .

When we say that the cylinder is "very nearly filled with liquid" we imply that before rotation commenced the pressure was just zero at the top BAE of the cylinder. When the liquid is rotating it is clear that the pressure is least at A , and so the pressure will be still zero there.

Draw a parabola PAP' with its axis in the direction OA and latus-rectum $\frac{2g}{\omega^2}$

The pressure at any point of the liquid is thus that due to its vertical depth below the surface generated by the revolution of this parabola.

(1) The thrust on the base CD therefore
 = weight of the liquid that would occupy the space between CD
 and this paraboloid
 = wt of cylinder PC - wt of paraboloid PAP'
 = wt of cylinder PC - $\frac{1}{2}$ wt of cylinder PB [Page x
 = $g\rho \pi r^2 \times DP$ - $\frac{1}{2} g\rho \pi r^2 \times EP$
 Now $PN^2 = \frac{2g}{\omega^2} AN$, i.e. $AN = \frac{\omega^2}{2g} AN^2$

thrust on CD
 = $g\rho \pi r^2 [DP - \frac{1}{2} EP] = \pi g\rho r^2 [h + \frac{1}{2} EP]$
 = $\pi g\rho r^2 [h + \frac{1}{2} AN] = \pi\rho r^2 \left[gh + \frac{\omega^2 r^2}{4} \right]$

(2) Again the thrust on BE is upwards, and is equal in magnitude to the weight of liquid that would occupy the volume between BE and the paraboloid, and thus

= wt of cylinder PB - wt of paraboloid PAP'
 = $\frac{1}{2}$ wt of $PB = g\rho \frac{1}{2} \pi r^2 AN$
 = $\frac{1}{4} \pi\rho r^4 \omega^2$

Ex 2 A circular cylinder, whose height is h and the radius of whose base is r , is initially filled with liquid, the cylinder and the liquid rotate about the axis with angular velocity ω , find how much of the liquid is spilt

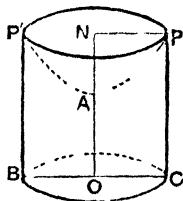

CASE I.

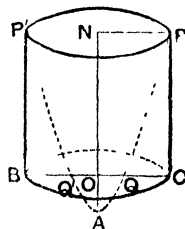

CASE II.

Let $P'BCP$ be the section of the cylinder by the plane of the paper, the axis being NAO

The free surface is a parabola, whose latus-rectum is $\frac{2g}{\omega^2}$, and it must go through P, P'

It is thus a parabola with vertex A , where $PN^2 = \frac{2g}{\omega^2} AN$, and hence

$$AN = \frac{\omega^2}{2g} PN^2 = \frac{\omega^2}{2g} r^2$$

(1) Let $\frac{\omega^2}{2g} r^2 < h$, so that $\omega < \frac{\sqrt{2gh}}{r}$, and therefore A is above O as in Case I

The liquid that has been spilt is that which would fill the paraboloid PAP' , and hence its volume

= half the cylinder whose base is PP' and height NA

$$= \frac{1}{2} \pi r^2 \times NA = \frac{1}{2} \pi r^2 \times \frac{\omega^2}{2g} r^2$$

$$= \frac{1}{4} \frac{\pi \omega^2 r^4}{g}$$

(2) If $\frac{\omega^2 r^2}{2g} = h$, then $NA = NO$, and the vertex A of the parabola coincides with the lowest point O of the axis

(3) If $\frac{\omega^2 r^2}{2g} > h$, then $NA > NO$, and the point A falls below O as in Case II. In this case the parabola meets BC in two points Q, Q' and we have

$$\begin{aligned} QO^2 &= \frac{2g}{\omega^2} AO = \frac{2g}{\omega^2} [AN - h] \\ &= \frac{2g}{\omega^2} \left[\frac{\omega^2 r^2}{2g} - h \right] = r^2 - \frac{2gh}{\omega^2}. \end{aligned}$$

In this case the volume that has been spilt

= volume of $PQQ'P'$

= paraboloid APP' - paraboloid AQQ'

$$= \frac{1}{2} \pi PN^2 \times AN - \frac{1}{2} \pi QO^2 \times AO$$

$$= \frac{1}{2} \pi r^2 \times \frac{\omega^2 r^2}{2g} - \frac{1}{2} \pi \left(r^2 - \frac{2gh}{\omega^2} \right) \left(\frac{\omega^2 r^2}{2g} - h \right)$$

$$= \frac{1}{4} \frac{\pi \omega^2 r^4}{g} - \frac{\pi \omega^2}{4g} \left(r^2 - \frac{2gh}{\omega^2} \right)^2 = \frac{\pi \omega^4}{4g} \left[\frac{4ghr^2}{\omega^4} - \frac{4g^2 h^2}{\omega^4} \right]$$

$$= \frac{\pi h}{\omega^2} [\omega^2 r^2 - gh].$$

Ex 3 A straight tube AB , of thin uniform cross section, rotates with uniform angular velocity ω about a vertical axis through the lower end A , find how much of the liquid flows out at the end B which is open.

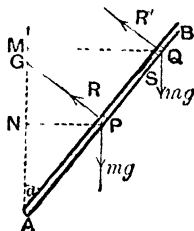

When the liquid is rotating in relative equilibrium, let P be its highest point. The pressure of the liquid there is clearly zero.

Consider the equilibrium of a very thin section of the fluid at P , whose mass is m . It is acted on by its weight mg acting vertically downwards, and the reaction R of the tube acting normally to it as marked. These two forces give it its normal acceleration $m \cdot \omega^2 PN$, where PN is perpendicular to the axis of rotation.

Resolving horizontally and vertically, we have

$$R \cos \alpha = m\omega^2 PN \quad (1),$$

and
$$R \sin \alpha = mg \quad (2),$$

where α is the inclination of the tube to the vertical.

Hence, by division,

$$\frac{\omega^2 \cdot PN}{g} = \cot \alpha, \text{ i.e. } PN = \frac{g}{\omega^2} \cot \alpha \quad (3)$$

$$AP = \frac{PN}{\sin \alpha} = \frac{g \cos \alpha}{\omega^2 \sin^2 \alpha}.$$

This gives the position of the highest point of the fluid.

It will be easily seen that the liquid above P will flow out. For, if there can be any liquid above P , let Q be the highest particle of it, and let QM , the perpendicular on AN , equal $NP + k$. To keep it in equilibrium let us assume that a force S must act on it towards A in addition to the normal force R' . We then have

$$R' \cos \alpha + S \sin \alpha = m\omega^2 \cdot MQ = m\omega^2 \cdot NP + m\omega^2 k \quad (4)$$

and
$$R' \sin \alpha - S \cos \alpha = mg \quad (5)$$

Eliminating R' , we have

$$\begin{aligned} S &= (m\omega^2 NP + m\omega^2 k) \sin \alpha - mg \cos \alpha \\ &= mg \cos \alpha + m\omega^2 k \sin \alpha - mg \cos \alpha, \text{ by (3),} \\ &= m\omega^2 k \sin \alpha. \end{aligned}$$

Hence S is positive, and hence our supposition is correct, thus to keep the element at Q it must be pulled towards A . But it cannot be pulled, hence it will move upwards along the tube and pass out at B .

Similarly for every other particle of liquid above P .

Ex 4 A semicircular tube is filled with water, and rotates about the diameter joining its two ends, which is vertical, where must a hole be made in the tube so that all the liquid may escape?

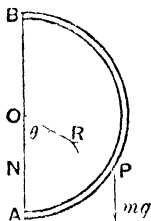

Wherever the hole is made some of the liquid will escape; but all the liquid cannot escape through the same hole, unless the hole is made at the point of the tube where the last drop of the liquid would be found, that is, at the point P of the tube where a single particle would be in relative equilibrium.

If then O be the centre, BOA be the vertical diameter, and PN be perpendicular to OA , a particle at P of mass m would be in relative equilibrium under the action of its weight mg and a force R along PO .

The resultant of these two must thus be $m\omega^2 PN$ along PN .

Hence, if $\angle AOP = \theta$, we have, by resolving horizontally and vertically,

$$R \sin \theta = m\omega^2 PN,$$

and

$$R \cos \theta = mg$$

$$\therefore \tan \theta = \frac{\omega^4}{g} PN,$$

$$\therefore ON = PN \cot \theta = \frac{g}{\omega^2},$$

and this gives the depth below O of the required point P .

EXAMPLES. XXXII.

1. A closed right circular cylinder is very nearly filled with water, and is made to rotate about its axis which is vertical, find the angular velocity when the whole thrust on the base is half as much again as when the liquid is at rest.

2. A closed circular cylinder is just filled with water, and rotates about its axis which is vertical, if the total thrust on the bottom is five times that on the top, prove that the angular velocity is $\frac{\sqrt{gh}}{r}$, where h is the height and r is the radius of the cylinder

3. If in the previous question one thrust is n times the other, then the angular velocity is $\frac{2}{r} \sqrt{\frac{gh}{n-1}}$.

4. A right circular cylinder, open at the top, is filled with water, and the whole of it revolves with uniform angular velocity ω about its axis. If not more than half the water is spilt, find the pressure at any point of the base

5. A hollow cone, very nearly filled with water, rotates uniformly about its axis which is vertical, the vertex being uppermost. If the pressure on the base be equal to six times the weight of the enclosed water prove that the angular velocity is $\sqrt{\frac{4g}{a} \cot \alpha}$, where a is the radius of the base and 2α the vertical angle of the cone

6. A cylindrical vessel, half full of water, is made to rotate about its axis which is vertical. Find the greatest angular velocity that may be given to it without the water being spilt, and shew that the centre of the base will be then just exposed

7. A cylinder, of radius a , is just full of water, being closed by a heavy lid which can turn about a point on its rim, prove that the lid will be lifted up when the cylinder and water are rotating with angular velocity ω about the axis of the cylinder, if its weight be less than $\frac{\pi}{4} \omega^2 a^4 \rho$, where ρ is the density of water.

8. When a cylinder, open at the top and half full of liquid, revolves with angular velocity Ω about its axis, which is vertical, the liquid just reaches the upper rim, prove that the angular velocity in order that $\frac{1}{n}$ th of the liquid may remain in the cylinder is $\Omega \sqrt{n}$.

9. A circular tube is half full of liquid and is made to revolve round a vertical tangent line with angular velocity ω , if a be the radius of the tube, prove that the diameter passing through the free surfaces of the liquid is inclined at an $\angle \tan^{-1} \frac{\omega^2 a}{g}$ to the horizon.

10. A quantity of water occupies a quadrant of a fine circular tube of given radius a . When the tube rotates with uniform angular velocity ω about a vertical diameter, the highest point of the water is at an angular distance of 60° from the highest point of the tube. Prove that $\omega^2 = \frac{2g}{a}(\sqrt{3} + 1)$.

11. Liquid is contained within a circular tube in a vertical plane which can rotate about a vertical diameter. If the liquid subtend an angle θ at the centre, the least angular velocity to make it divide into two parts is $\sqrt{\frac{g}{a}} \sec \frac{\theta}{4}$.

12. A heavy liquid is contained in a circular tube, of radius a and of fine bore, the liquid filling one-fourth of the tube. It is set rotating about a vertical diameter with angular velocity ω . If $\omega^2 = \frac{2g\sqrt{2}}{a}$, shew that the level of the liquid will just rise to the horizontal diameter whilst the depth of the free surface below the centre is $a\sqrt{2}$.

13. A circular tube, of radius a and small cross section, contains a quantity of water which would subtend an angle of 30° at the centre. It turns about the vertical diameter with angular velocity $2\sqrt{\frac{g}{a}}$, shew that the highest point of the water is at the end of the horizontal diameter, the whole of the water being on one side of the vertical diameter.

14. A tube, of small section, is in the form of three sides of a square of which the middle one is horizontal, it is filled with water and revolves about a vertical axis through the middle point of the horizontal side, prove that no liquid escapes unless $\omega > \sqrt{\frac{8g}{a}}$, and that, if this be so, the amount that escapes would fill a length of the tube equal to $a\sqrt{1 - \frac{8g}{\omega^2 a}}$, where a is the side of the square.

15. In the previous question, if the tube revolve about a vertical side, prove that the amount which will flow out would fill a length

$$\frac{\omega^2 a^2}{2g}, \text{ or } a + \sqrt{a^2 - \frac{2ga}{\omega^2}},$$

according as

$$\omega \leq \sqrt{\frac{2g}{a}}.$$

16. A cylinder, of radius a and height h , contains a liquid of depth b . If the cylinder and liquid revolve about the axis, which is vertical, shew that the greatest angular velocity in order that no liquid may flow out is

$$\frac{2}{a} \sqrt{g(h-b)} \quad \text{or} \quad \frac{h}{a} \sqrt{\frac{g}{b}},$$

according as b is $>$ or $<$ $\frac{1}{2}h$

17. A cubical box, open at the top, whose base is horizontal is filled with water and made to rotate about a vertical axis through its centre. If the centre of the base be just uncovered, shew that the angular velocity is $\sqrt{\frac{8g}{a}}$, where a is the side of the cube

18. A conical vessel, of height h and vertical angle 2α , contains water whose volume is one half that of the cone, if the vessel and the contained water revolve with uniform angular velocity ω , and no water overflows, shew that ω must be not greater than $\sqrt{\frac{2g}{3h}} \cot \alpha$.

19. A vessel, in the form of a hemisphere of radius a , is full of liquid, and is made to rotate with uniform angular velocity ω about the vertical radius of the bowl, how much of the liquid runs over?

20. A vessel in the form of a right cone with its vertex downwards is filled with liquid and revolves with uniform angular velocity ω about the axis, if h be the height and 2α the vertical angle of the cone, shew that the amount of the liquid that is spilt is

$$\frac{1}{4} \frac{\pi \omega^2 h^4}{g} \tan^4 \alpha,$$

provided that

$$\omega > \sqrt{\frac{g}{h}} \cot \alpha$$

21. A vessel, in the form of a portion of a paraboloid of revolution formed by the revolution of a parabola of latus-rectum $4a$ about its axis, is filled to half its height with liquid, what is the greatest angular velocity with which it can revolve about its axis so that no liquid is spilt?

22. Water is contained in a cup formed by the revolution of a parabola about its axis, the water and cup revolve with uniform angular velocity ω about the axis, if the latus-rectum of the parabola be $< \frac{2g}{\omega^2}$, shew that all the water would escape through a hole at the lowest point of the cup.

23. A hemispherical bowl, just full of water, is inverted and placed with its mouth downwards on a smooth horizontal table, so that no water escapes under the edge of the bowl. The vessel and contained liquid is then made to rotate with angular velocity ω , and the vessel is on the point of rising, prove that its weight is to the weight of the contained water as

$$4g + 3\omega^2 a \quad 8g.$$

24. A cup in the form of a paraboloid of revolution cut off by a plane perpendicular to the axis is just filled with liquid, and placed with its vertex upwards on a horizontal plane. The whole is made to revolve about the axis of the cup; prove that the liquid will escape when the angular velocity exceeds $\sqrt{\frac{g}{2a} \frac{W-w}{w}}$, where W , w are the weights of the cup and liquid, and $4a$ is the latus-rectum of the parabola

25. A circular cylinder, of radius r , is floating freely in water with its axis vertical. At first the water is at rest and it is then made to rotate about an axis coinciding with the axis of the cylinder with angular velocity ω . Shew that in the second case an extra length $\frac{\omega^2 r^2}{4g}$ of the surface of the cylinder is wetted.

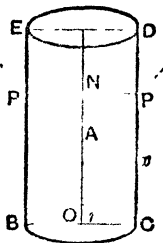

Let h be the height of the cylinder, ρ its density and σ that of the water. Then in the first case a height $\frac{\rho}{\sigma} h$ is wetted

In the second case let the water meet the cylinder in a circle of radius NP .

If we draw through P , P' a parabola PAP' whose latus-rectum is $\frac{2g}{\omega^2}$ and whose axis is that of the cylinder, this is the section of the free surface.

Then $PN^2 = \frac{2g}{\omega^2} AN$, i.e. $AN = \frac{\omega^2 r^2}{2g}$.

If x be the length CP of the portion of the surface which is now in contact with the water, then

$$\begin{aligned} \pi r^2 h \rho &= \text{weight of the cylinder} \\ &= \text{weight of the displaced water } BP'AP'O \\ &= \sigma [\pi r^2 x - \text{volume of } PAP'] \\ &= \sigma [\pi r^2 x - \pi r^2 \cdot \frac{1}{2} AN] \\ \therefore h\rho &= \sigma [x - \frac{1}{2} AN] = \sigma \left[x - \frac{\omega^2 r^2}{4g} \right] \\ \therefore x &= \frac{\rho}{\sigma} h + \frac{\omega^2 r^2}{4g}. \end{aligned}$$

26. A cone, of semi-vertical angle 30° and of height h , floats with its axis vertical and vertex downwards in a liquid whose density is one-third greater than its own; shew that the rim of its base will be just immersed if the liquid rotate with angular velocity $\sqrt{\frac{g}{h}}$ about a vertical line coinciding with the axis of the cone

27. A small cork, of mass m and sp. gr. σ , is tied by a fine string of length l to a point in the side of a vessel containing water. When the system is revolving in relative equilibrium with constant angular velocity about a vertical axis, shew that the tension of the string is $m l g \left(\frac{1}{\sigma} - 1 \right) - h$, where h is the height of the cork above the point of attachment

Let y be the horizontal distance of the cork from the axis of rotation. The pressure produced by the surrounding liquid on the cork will be the same as would act on the liquid which would occupy the same space as the cork. The mass of this liquid is $\frac{m}{\sigma}$, and the pressure would balance its weight $\frac{m}{\sigma} g$ and provide the necessary force $\frac{m}{\sigma} \omega^2 y$ toward the axis. These two forces, together with the tension T of the string and the weight mg of the cork, must provide the necessary normal acceleration $m\omega^2 y$ toward the axis. Hence, if θ be the inclination of the string to the vertical,

$$T \cos \theta + mg = \frac{m g}{\sigma} \quad (1),$$

$$\text{and} \quad m\omega^2 y = \frac{m}{\sigma} \omega^2 y - T \sin \theta \quad (2).$$

From (1) we have the required result.

28 A small sphere (sp gr > 1) is attached by a string of length l to a point in a vertical axis, about which a mass of water is rotating with uniform angular velocity ω . The sphere is immersed in the water and is in relative equilibrium; shew that there is a position of equilibrium in which the string is not vertical, provided that $\omega > \sqrt{\frac{g}{l}}$, in which case the position is one of stability.

CHAPTER XI.

MISCELLANEOUS PROPOSITIONS

168. Surface of Buoyancy If a body, which is floating in a liquid, move about so that it takes up in succession every position in which the volume of liquid displaced by it remains unchanged, the locus of the Centre of Buoyancy of the body is called the Surface of Buoyancy

If the body be a lamina, or if it be so displaced that the Centre of Buoyancy always remains in the same plane, its locus is called the **Curve of Buoyancy**.

The section in which the surface of any liquid cuts a body which is floating in it is called the **Plane of Floatation**.

169. *The tangent plane at any point of the surface of buoyancy is parallel to the corresponding plane of floatation*

Consider the case of a cylindrical body whose cross section is the curve ABA' .

Let ACA' be the original plane of floatation and H the corresponding centre of buoyancy, *i.e.* the corresponding centre of gravity of the displaced fluid ABA' .

Let the body be turned through a small angle, so that aCa' is the new plane of floatation, and so that the volume immersed remains the same,

i.e. so that volume $ACa = \text{volume } A'Ca' = V'$ (say)

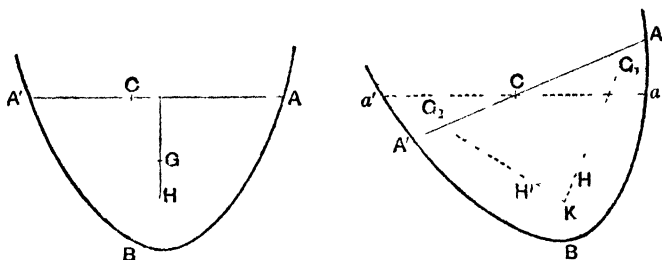

Let V be the volume of $aBA'C$, and G_1, G_2 the centres of gravity of the volumes $ACa, A'Ca'$ respectively.

Join G_1H and produce it to K , so that

$$G_1H \cdot HK = V \cdot V',$$

and $\therefore V' \times G_1H = V \times HK \dots (1)$

Hence, as in *Statics*, Art 116, K is the centre of gravity of the volume $aBA'C$

Join KG_2 , and on it take H' such that

$$KH' \cdot H'G_2 \therefore V' : V \dots (2)$$

Hence $V \times KH' = V' \times H'G_2$,

and hence H' is the centre of gravity of V at K and V' at G_2 ,

i.e. H' is the centre of gravity of $aBA'a'$ and hence is the new centre of buoyancy

By (1) and (2), we have

$$\frac{G_1H}{HK} = \frac{V}{V'} = \frac{G_2H'}{H'K},$$

and thus, by Euc. VI. 2, G_1G_2 is parallel to HH' .

If now the angle $AC\alpha$ be made indefinitely small, the points H and H' become consecutive points on the surface of buoyancy, and the line G_1G_2 ultimately coincides with AA'

Hence ultimately the tangent plane to the surface of buoyancy at H is parallel to the corresponding plane of floatation AA'

170. A proof similar to that of the previous article will apply to the case of any floating body whether cylindrical or not. In the general case we shew similarly that the line joining H to any consecutive point H' on the surface of buoyancy is parallel to the plane of floatation.

171. *The positions of equilibrium of a floating body are found by drawing normals from the centre of gravity of the body to the surface of buoyancy*

For, in the first figure of Art 169, GH is vertical (Art 57) and is therefore perpendicular to AA' , hence, by the result of Art 169, GH is perpendicular to the tangent plane at H to the surface of buoyancy

Hence GH is a normal to the surface of buoyancy at H .

The possible positions of equilibrium for any floating body are thus found by drawing normals from the centre of gravity of the body to the surface of buoyancy

172. *The Metacentre is the centre of curvature at the point H of the curve of buoyancy*

For, in Art 68, we defined the metacentre M as the intersections of the verticals through H and a consecutive centre of Buoyancy H' .

But, by the last article, these two verticals are the normals to the curve of buoyancy at H and H' .

Hence the metacentre M is the intersection of the normal at H to the curve of buoyancy with the consecutive normal at H' ,

i.e. M is the centre of curvature at H of the curve of buoyancy

173. *Particular cases of the Curve of Buoyancy*

If the body in Art 169 be a triangle PQR partially immersed in liquid with its vertex P in the liquid and the base QR entirely outside the liquid, the plane of floatation cuts off a triangle PAA' whose area is constant

The corresponding centre of buoyancy H is on the straight line PD , where D is the middle point of AA' and $PH = \frac{2}{3} PD$.

If LL' be drawn horizontally through H to meet PQ , PR in L and L' , then

$$\text{area } PLL' = \frac{PH^2}{PD^2} \times \text{area } PAA' = \frac{4}{9} \times \text{area } PAA' = \text{const}$$

Thus LL' cuts off a constant triangle PLL' , and hence we know, from the properties of Conic Sections, that LL' always touches at its middle point H a hyperbola whose asymptotes are PL and PL'

The locus of H , *i.e.* the curve of buoyancy, is thus in this case a hyperbola of which the immersed sides of the triangle are asymptotes

In the case where the portion of the body immersed in the liquid is a rectangle, it can be shewn that the curve of buoyancy is a parabola

174. *Position of the Metacentre* The determination of the position of the Metacentre is beyond the limits of this book.

In the case where the body is a symmetrical one, and the displacement is such that the point C in the figure of Art 169 is the centre of gravity of the plane of floatation ACA' , it can be shewn that the distance HM [Fig Art. 67]

$$= \frac{A k^2}{V},$$

where A = area of the section ACA' of the body made by the plane of floatation, and V = volume of the immersed portion of the body

When the section of the body by the plane of floatation is a rectangle [including the case of a straight line when the body is a lamina], $k^2 = \frac{CA^2}{3}$

When the section is a circle, $k^2 = \frac{CA^2}{4}$.

In general the determination of k^2 is a problem requiring the use of the Integral Calculus

[The quantity $A k^2$ is what, in the Dynamics of a Rigid Body, is known as the Moment of Inertia of the Plane of Floatation about a line through C perpendicular to the plane of the paper]

175. Assuming the result of the previous article, we can find the condition of stability in some simple cases

Ex 1 *Cube, of side $2a$ and density ρ , floating in a liquid of density σ*

Here $A = 4a^2$, $k^2 = \frac{a^2}{3}$, $V = 4a^2x$, where x = the depth immersed

$$= \frac{2a\rho}{\sigma}.$$

$$\therefore HM = \frac{A k^2}{V} = \frac{a^2}{3x}.$$

Hence the equilibrium is stable for a small angular displacement if

$$HM > HG,$$

i.e. if
$$\frac{a^2}{3x} > a - \frac{x}{2},$$

i.e. if
$$\frac{a^2}{3} > \frac{2a^2\rho}{\sigma} - \frac{2a^2\rho^2}{\sigma^2},$$

i.e. if
$$\sigma^2 > 6\rho(\sigma - \rho)$$

Ex 2 Circular cylinder, of radius r and height h , whose density is ρ , floating with its axis vertical in a liquid of density σ

If x ($= \frac{\rho h}{\sigma}$) be the length immersed,

$$HM = \frac{Ak^2}{V} = \frac{\pi r^2 \times \frac{r^2}{4}}{\pi r^2 \times x} = \frac{r^2}{4x}$$

Hence the equilibrium is stable for a small angular displacement if

$$HM > HG,$$

i.e. if
$$\frac{r^2}{4x} > \frac{h}{2} - \frac{x}{2},$$

i.e. if
$$r^2 > 2h^2 \left[\frac{\rho}{\sigma} - \frac{\rho^2}{\sigma^2} \right].$$

Ex 3 Cone, of density ρ , whose height is h and the radius of whose base is a , floating with its axis vertical and vertex downwards in a liquid of density σ

If x be the length of the axis immersed, and b be the radius of the section by the plane of floatation, then

$$\frac{1}{3}\pi b^2 x \sigma = \frac{1}{3}\pi a^2 h \rho, \text{ and } \frac{b}{x} = \frac{a}{h},$$

so that

$$x^3 \sigma = h^3 \rho.$$

Also
$$A = \pi b^2, k^2 = \frac{b^2}{4}, \text{ and } V = \frac{1}{3}\pi b^2 x.$$

$$HM = \frac{Ak^2}{V} = \frac{3b^2}{4x} = \frac{3}{4} \frac{a^2}{h^2} x.$$

Hence the equilibrium is stable if $HM > HG$,

i.e. if
$$\frac{3}{4} \frac{a^2}{h^2} x > \frac{3h}{4} - \frac{3x}{4},$$

i.e. if
$$x > h \times \frac{h^2}{h^2 + a^2}, \text{ i.e. } > h \cos^2 \alpha,$$

i.e. if
$$\frac{\rho}{\sigma} = \frac{x^3}{h^3} > \cos^6 \alpha,$$

where α is the semi-vertical angle of the cone.

EXAMPLES. XXXIII.

1. A rectangle, of sides $2a$ and $2b$ and of density ρ , is floating with the side $2b$ vertical in a liquid of density σ , shew that the equilibrium is stable for a small angular displacement if

$$\frac{a^2}{6b^2} > \frac{\rho}{\sigma} - \frac{\rho^2}{\sigma^2}$$

2. A uniform rectangular block, of sp gr $\frac{1}{2}$, floats in water with one edge vertical. If b be the length of the shortest horizontal edge and c that of the vertical edge, prove that for stability

$$b > \frac{c}{2} \sqrt{6}$$

3. A circular cylinder floats with its axis horizontal in a liquid of twice its own density, it is displaced in a vertical plane through the axis, shew that its equilibrium is stable if its height is greater than the diameter of its base

4. The cone in Ex 3, Art 175, is floating with its vertex upwards, prove that the equilibrium is stable if

$$\rho < \sigma(1 - \cos^2 \alpha)$$

5. In a ship, of total displacement M tons and metacentric height h feet, a gun of mass m tons is moved a distance of l feet across the deck, prove that this will cause the ship to heel over through a small angle whose circular measure is approximately $\frac{ml}{Mh}$

[The metacentric height is the height of the metacentre above the centre of gravity of the body, i.e. GM in the figures of Page 82]

6. In H M S Achilles, a ship of 9000 tons displacement, it was found that, when 20 tons was moved through a distance of 42 feet from one side of the deck to the other, the bob of a pendulum 20 feet long was caused to move through 10 inches. Shew that the metacentric height was 2.24 feet

[This example and the previous one shew how the metacentric height of a ship may be experimentally determined]

TENSIONS OF VESSELS CONTAINING FLUIDS

176. Suppose a cylindrical vessel to be formed of some thin flexible substance, such as silk, and to be filled with gas at a certain pressure which will be the same throughout

Consider any length AB of the surface which is in the direction of the axis of the cylinder. It is clear that the pressure of the gas will cause a tension in the silk and, by symmetry, the action across AB must be perpendicular to AB .

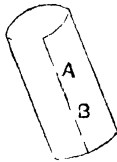

If T is the total force that must be exerted perpendicular to AB to keep together the two parts on each side of AB , then the quantity $\frac{T}{AB}$, i.e. the force required per unit of length, is called the tension across AB and is generally denoted by t .

If the silk be not strong enough to bear this tension t , it will be torn asunder.

177. In many cases the total action on such an element as AB is not perpendicular to AB . In this case, in addition to the force just spoken of, there is a tangential action, or shearing stress, along AB . We shall not however consider any cases in which this tangential action exists

178. A vessel in the form of a circular cylinder, with its axis vertical, is filled with liquid; find the tension at any point of it

Let $ABCD$ be the cylinder, and let PRQ , $P'R'Q'$ be two horizontal very near sections of the cylinder.

Since PP' , QQ' are very small, the pressure at any point between the two sections may be treated as constant ($= p$ say)

Let t be the tension across PP' , or QQ' , it is clear that t will be the same at all points on the same horizontal section

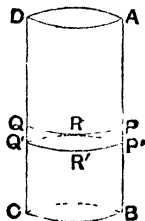

Consider the equilibrium of the semi-circular portion bounded by PP' , QQ' and the two semi-circles PRQ , $P'R'Q'$.

It is acted upon in a horizontal plane by the tensions t PP' and t QQ' across PP' and QQ' in directions perpendicular to the plane of the paper, and by the resultant horizontal pressure on $PP'R'Q'QRP$

This latter is, by Art 52, equal to the horizontal pressure on the rectangle $PQQ'P'$, and thus

$$= PQ \times PP' \times p$$

Hence $2t \ PP' = PQ \times PP' \times p,$

i.e. $t = p \cdot \frac{PQ}{2} = p \cdot r,$

where r is the radius of the cylinder

Cor. If the cylinder be filled with a gas, the pressure p is practically constant throughout, and the relation $t = pr$ is then true even if the axis of the cylinder is not vertical

179. *A spherical surface of radius r contains gas at a given pressure p ; if t be the tension of the surface at any point, then $2t = p \cdot r$*

The tension t is constant by symmetry

Take any plane through the centre of the sphere and let it meet the sphere in the circle $ACA'D$. Consider the equilibrium of the hemisphere $ACA'B$ cut off by it

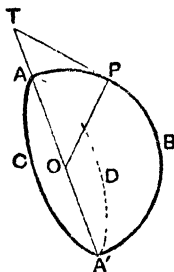

At every point of ACA' there is a tension t acting perpendicular to the plane ACA' .

$\therefore t \times 2\pi r =$ force perpendicular to the plane ACA'

This must be balanced by the resultant pressure in the same direction

Now the pressure on a small element a of area at l perpendicular to the plane ACA'

$$= a \times p \sin POA = p \times a \cos PTA,$$

where PT is the tangent at P ,

$$= p \times \text{projection of } a \text{ on the plane } ACA'.$$

Similarly for every other such small element

• resultant pressure on ABA' perpendicular to the plane ACA'

$$= p \times \text{whole projection of } ABA' \text{ on the plane } ACA'$$

$$= p \times \text{area } ACA' = p \times \pi r^2.$$

$$\text{Hence} \quad t \times 2\pi r = p \times \pi r^2,$$

$$\text{ie} \quad 2t = p r.$$

By a comparison of the results of Arts 178 and 179, it follows that if we have a cylindrical vessel and a spherical vessel of the same radius, and containing gas at the same pressure, then the tension of the former is twice that of the latter. Hence the former must be made twice as strong as the latter to withstand the same pressure.

180 In both Arts 178 and 179, when the surface is subjected to an internal pressure p and an external pressure Π , we must instead of p read $p - \Pi$.

181. When we have a cylinder made of a substance of small finite thickness we must, in considering its strength, take into account its thickness also. Thus, if we are given that a substance will bear a tension of τ per unit of area, then in the case of a thickness c of the substance we have

$$t = c\tau$$

Ex The tensile strength of a metal is 16000 lbs per sq inch, find the fluid pressure per sq inch that will just burst a spherical vessel of that material, its radius being one foot and its thickness $\frac{1}{10}$ inch

$$\text{Here} \quad t = \frac{1}{10} \times 16000 \text{ lbs wt}$$

Hence the formula $2t = pr$ gives

$$p \times 12 = 2 \times 1600 = 3200$$

$$\therefore p = \frac{3200}{12} = 266\frac{2}{3} \text{ lbs wt. per square inch.}$$

EXAMPLES. XXXIV.

1. Two boilers have hemispherical ends, the radius of the first is three times that of the second and it is twice as thick, find the ratio of the greatest pressures that they can withstand

2. A certain metal can bear a tension of 12000 lbs per square inch, find what fluid pressure would just burst a cylindrical pipe made of it, the radius of the pipe being 6 inches and its thickness a quarter of an inch

3. A pipe 8 inches in internal diameter is used for transmitting water to a height of 200 feet. If the metal of which the pipe is made will only bear a strain of 10000 lbs per sq inch, find the smallest thickness that the pipe can have, the weight of a cubic foot of water being assumed to be $62\frac{1}{2}$ lbs

4. An india rubber ball containing air has a radius a when the temperature is 0°C . If the tension of the rubber is always μ times the square of the radius of the ball, find the radius when the temperature is $t^{\circ}\text{C}$.

MISCELLANEOUS EXAMPLES.

1. The sp gr of ice is .92 and that of sea water is 1.025. What depth of water will be required to float a cubical ice-berg of side 100 yards?

2. A piece of wood, weighing a kilogramme, floats in water with $\frac{3}{8}$ ths of its volume immersed; find the density and the volume of the wood.

3. A piece of wood, of sp gr $\frac{2}{3}$, is floating in oil, of sp gr .84, what fraction of its volume is immersed?

4. A wide-mouthed bottle, full of air, is closed by a well-ground glass stopper, 5 cms in diameter, the barometer standing at 772 mm, what weight must the stopper have in order that it may be just lifted if the barometer goes down to 730 mm, the temperature remaining unaltered? [1 c.c. of mercury weighs 13.6 grammes]

5. In the experiment of Archimedes, Hiero's crown, together with masses of gold and silver equal in weight to the crown, were weighed in water in succession. The crown lost $\frac{1}{4}$ th of its weight, the gold $\frac{1}{7}$, and the silver $\frac{2}{11}$. In what proportion by weight were gold and silver mixed in the crown?

6. A closed cubical vessel, with sides one inch in thickness, is made of material whose sp gr is $2\frac{3}{5}$. If the vessel can float in water, shew that its internal volume must be at least 1000 cubic inches.

7. A body is composed of a hemisphere, of radius r , with a cone, of height $2r$, on the same plane base. In a liquid of density ρ_1 it floats with the whole body just immersed, and in a liquid of density ρ_2 with the hemisphere just immersed, prove that $\rho_2 = 2\rho_1$.

8. A cylinder, loaded so as to float vertically and weighing 2 grammes altogether, just sinks in water when half a gramme extra is put on its top, otherwise it protrudes 7 cms above the surface. What length will appear above the surface of a liquid whose density is five times that of water, if the cylinder be set floating in it without the extra load?

9. An empty balloon with its car and appendages weighs in air 1200 lbs. If a cubic foot of air weighs $1\frac{1}{4}$ ozs., how many cubic feet of gas of sp. gr. 52 times that of air must be introduced before it begins to ascend?

10. A glass tumbler weighs 8 ozs ; its external radius is $1\frac{1}{2}$ inches and its height is $4\frac{1}{2}$ inches ; if it be allowed to float in water with its axis vertical, find what additional weight must be placed in it to sink it

11. A rod of cork 8 ins long and a rod of lignum vitæ 4 ins long are joined together to form a straight rod, one foot long, of uniform section. When the rod floats in water it is found that it can rest with part of the cork above the water and its axis inclined at any angle to the vertical. If the sp gr. of cork be 24, find that of lignum vitæ.

12. A piece of wood weighs 6 lbs in air, a piece of lead which weighs 12 lbs in water is fastened to it and the two together weigh 10 lbs. in water ; what is the sp gr of the wood ?

13. A body, of sp gr ρ , floats half immersed in a liquid, but is three quarters immersed in a mixture of equal volumes of the liquid and water. Neglecting the atmospheric pressure, find ρ

14. A retort, of 3 litres capacity, and with its open end submerged 34 cms below the surface of water in a trough, is seen to be completely full of air on a certain day. Next day the mercury barometer is observed to have fallen 2 cms to 74 cms. There being no change of temperature, how much of the air originally in the retort has by this time bubbled out? [Sp gr of mercury = 13.6]

15. The length of a barometer tube is 80 inches and its diameter half an inch, except for one inch of its length where a cylindrical tube is inserted so as to increase the diameter of the tube to 3 inches. The bottom of the bulb is 27 inches above the mercury in the tank. The lower half of the bulb, and the tube below, contain mercury, and the upper half of the bulb and the tube above contains water. If the mercury barometer rises 5 inch, through what distance will the upper surface of the water move, the sp. gr. of mercury being 13.67?

16. A balloon is filled with a gas whose sp gr is $\frac{1}{3}$ that of air at a pressure of 760 mm. of mercury. Compare the lifting power of the balloon when the barometric height is 750 mm with the lifting power when the height is 760 mm. The temperature of the air is 0°C in both cases, and the volume of the balloon is unaltered.

17. A sphere of radius r and weight $\pi r^2 kv$, where v is the weight of unit volume of water, is placed in and fits a vertical cylinder, of height h , which is open to the air at the top and closed at the bottom. When the sphere is in a position of equilibrium, shew that its centre is at a depth x below the top of the cylinder given by the equation

$$x(H+k) = k\left(h - \frac{2r}{3}\right),$$

where H is the height of the water-barometer.

18. A vessel A contains a quantity of liquid of sp gr ρ , and a second cask an equal quantity of liquid of sp gr σ ; one n th part of each is taken out and put into the other and well mixed, the process is repeated m times, shew that the final specific gravities are

$$\rho + \frac{\sigma - \rho}{2} \left\{ 1 - \left(1 - \frac{2}{n} \right)^m \right\} \text{ and } \sigma + \frac{\rho - \sigma}{2} \left\{ 1 - \left(1 - \frac{2}{n} \right)^m \right\}.$$

19. A cylindrical vessel, of radius r and height h , is three fourths filled with water, find the largest cylinder, of radius r_1 ($< r$) and sp gr σ , which can be floated in the water without causing any to run over.

20. A triangle ABC is immersed in a fluid with one side BC in the surface, find a point O within the triangle such that if it be joined to the angular points the thrusts on the three triangles thus formed may be equal.

21. A right circular cylinder contains liquid, a right solid cone, the base of which exactly fits the cylinder, floats in the liquid vertex downwards, if the density of the cone be such that its centre of gravity is in the surface of the liquid, find the ratio between the densities of the cone and liquid, and the distance through which the surface of the liquid will fall when the cone is removed.

22. A solid hemisphere, whose radius is three inches, is held under mercury with its base vertical and its centre 6 inches below the surface of the mercury. Assuming the weight of a cubic inch of mercury to be w , find the direction and magnitude of the resultant thrust on the curved surface.

23. Four equal uniform rods are joined together to form the sides of a square and the square is set floating vertically in a liquid. If the density of the liquid lies between three and four times that of the rods, shew that the square can float with one corner only unimmersed and with neither diagonal horizontal.

24. From one arm of a balance hangs a large bucket containing water, and from the other a weight W of sp gr s , which is entirely immersed in the water in the bucket and does not touch the bottom. If there is equilibrium, and if W' is the weight of the bucket and

water, prove that $s = \frac{2W}{W - W'}$, and that the volume of the water is

not $> \frac{2W'}{W - W'}$ that of the weight W .

25. A cylinder is floating in a liquid, a hollow vessel is inverted over it and depressed so that the pressure of the air inside is increased from Π to Π' , what effect is produced in the position of the cylinder (1) with reference to the fluid in the vessel, and (2) with reference to the surface of the fluid outside?

26. ABC is an isosceles triangle, right angled at A , composed of two heavy rods AB, AC hinged together at A and a string BC without eight floats with the angle A immersed in water. Shew that the tension of the string is $\frac{a-b}{2a}W$ where $2a$ = length of a rod, $2b$ = length immersed and W = weight of each rod.

27. A vessel contains layers of equal thickness h of different fluids which do not mix and whose densities are in A.P. A cone, the length of whose axis is $3h$, floats in equilibrium (1) with its vertex downwards and its base in the upper surface, and (2) with its vertex upwards and its base in the surface between the second and third liquids. Shew that the densities of the cone and the liquids are in the ratio of 31 30 33 36

28. A circular cylinder, whose height is h and whose sp. gr. is σ , is partially immersed in water with its axis vertical, being held up by an elastic string which has one end attached to the middle point of the upper base of the cylinder and the other end attached to a point vertically over this middle point. If the unstretched length, a feet, of the string be just sufficient to allow the lower end of the cylinder to touch the water, and the coefficient of elasticity be n times the weight of the cylinder, shew that the depth to which the cylinder is immersed is $\frac{h\sigma a}{nh\sigma + a}$.

29. A cylindrical diving bell of volume 450,000 cub cms is lowered into water to a depth of 1700 cms and it is then found that an addition of 750,000 cub cms at atmospheric pressure is required to fill the bell. Find the height of the water barometer and the pressure on the surface of the water inside the bell in dynes per sq. cm., the value of g being 980.

30. A U-tube with its legs vertical and at a distance c apart contains mercury and is whirled round one of the legs as axis with uniform angular velocity ω , the cross sections of the legs being σ_1 and σ_2 . Shew that the mercury in the revolving leg σ_2 will rise above the mean level by an amount $\frac{\sigma_1}{\sigma_1 + \sigma_2} \frac{\omega^2 c^2}{2g}$.

31. If a man of weight w stands at the middle of a uniform plank, of weight W and of length a and thickness b , which is floating in water, it is found that two-thirds of the volume of the plank is immersed. Shew that he can walk the whole length of the plank without any part of the upper surface becoming immersed, provided that $\frac{w}{W}$ is not $> \frac{9a^2 - 10b^2}{45a^2 + 46b^2}$.

32. A hollow cone floats with its vertex downwards in a cylindrical vessel containing water. In the position of equilibrium the area of the circle, in which the cone is intersected by the surface of the fluid, bears to the base of the cylinder the ratio 6 : 19. If a volume of water equal to $\frac{19}{8}$ ths of the volume originally displaced by the cone be poured into the cone, and an equal volume into the cylinder, shew that the position in space of the cone will be unaltered.

33. At a place where the height of the water-barometer is 34 feet and the temperature of the air is 0°C , a diving bell, of capacity 84 cub feet, and which is originally full of air at atmospheric pressure and temperature, is lowered into water at 7°C till its lower edge is 17 feet below the surface. How many cubic feet of air at atmospheric pressure and temperature must be pumped into the bell, so that when the contained air has acquired the temperature of the water it may just fill the bell? [$\alpha = \frac{1}{2} \frac{1}{\tau}$]

34. A cylindrical diving bell is lowered into water, neglecting the thickness of the bell, draw a curve showing how the tension of the chain varies, starting from the position in which the bell is just immersed.

35. A diving bell is in the form of a cylinder surmounted by a hemisphere, c is the length and a the radius of the cylinder. Find how far the bell must be sunk so that the hemisphere is the only part containing air, shew that in this position the volume of air at atmospheric pressure that must be forced in to clear the whole bell from water must be $\left(\frac{c}{H} + \frac{3}{2} \frac{c}{a}\right)$ times the volume of the bell, H being the height of the water-barometer.

36. A bent tube, of small uniform bore, consists of two straight legs, of which one is horizontal and closed at the end, and the other is vertical and open. If the horizontal leg be filled with mercury, and the tube revolve about a vertical axis through the closed end with angular velocity ω , prove that the mercury will rise to a height d in the vertical leg, such that $\omega^2 = \frac{2g(h+d)}{l^2 - d^2}$, where l is the length of the horizontal leg and h is the height of the mercury barometer. Shew also that the mercury will not rise at all, unless $\omega^2 l^2 > 2gh$.

37. Some liquid occupies a portion of a circular tube, of radius a and small cross section, and subtends an angle $\pi + \theta$ at the centre. The tube rotates with uniform angular velocity ω about the vertical tangent, and the liquid then just reaches the highest point, prove that $a\omega^2 \left[\tan \frac{\theta}{2} - \sin^2 \frac{\theta}{2} \right] = g$

38. A spherical vessel contains a quantity of water whose volume is to the volume of the vessel as $n^3 - 1$, prove that no water can escape through a small hole at the lowest point if the water revolve with an angular velocity whose square is not less than $\frac{g}{r(1-n)}$, where r is the radius of the vessel.

39. Liquid is rotating in a cylinder, of radius r , whose bottom is closed by a conical surface of semi vertical angle α , the vertex being downwards. Shew that the pressure at the surface of the cone is least at a point distant $\frac{1}{2}l \cot \alpha$ from the axis, where l is the latus rectum of the free surface, provided that $l < 2r \tan \alpha$.

40. A hollow cone, vertex upwards, is three quarters full of water, and is set rotating about its axis, which is vertical, with an angular velocity $\sqrt{\frac{8g}{3h}} \cot \alpha$, where α is the semi vertical angle and h is the height of the cone. Shew that the thrust on the base is to the weight of water in the vessel as 10 : 3.

41. An elliptic tube half full of liquid revolves about a fixed vertical axis in its plane with angular velocity ω , shew that the angle which the straight line joining the free surfaces of the liquid makes with the vertical is $\tan^{-1} \left(\frac{g}{p\omega^2} \right)$, where p is the distance of the axis from the centre of the ellipse.

42. A hemispherical bowl, of radius a , is full of water which is stirred by the hand till the whole has acquired a uniform angular velocity about the axis of the hemisphere. Find this angular velocity supposing half the water has been spilled.

43. A right cone of semi-vertical angle α is just immersed with its slant side, of length l , in the surface of a liquid. Shew that the resultant thrust on the curved surface will cut this slant side at a distance $\frac{3l}{4(1-3\sin^2\alpha)}$ from the vertex, and find the magnitude of this thrust.

44. A hemisphere, of weight w and sp. gr. σ , fixed at a point on its rim, is loaded at another point, at the distance of a quadrant measured along the rim from the former, with a particle of weight nw , and the whole is completely immersed in liquid. Find the inclination of the plane of the base to the horizon.

If $\sigma = \frac{1}{1+n}$, prove that the inclination is $\cos^{-1} \frac{3}{\sqrt{73}}$

45. A conical shell is divided by a plane through its axis into two halves, which are hinged at the vertex, and stands on a smooth table. If water can be poured in through a small hole at the vertex till the cone is quite full, prove that the ratio of the weight of the water to the weight of the shell must be less than each of the fractions $\frac{1}{3}$ and $\frac{4 \sin^2 \alpha}{9}$.

46. A hemispherical shell is floating on the surface of a liquid, if the greatest weight that can be placed on its rim be n times the weight of the hemisphere, shew that the ratio of the weight of the hemisphere to the weight of the liquid it could contain is

$$(1 - \sin \alpha)^2 (2 + \sin \alpha) \cdot 2(n + 1), \text{ where } \tan \alpha = 2n$$

[N B The volume of the portion of a sphere of radius a which is cut off by a plane at a distance x from the centre is $\frac{\pi}{3}(a-x)^2(2a+x)$]

47. Given the height h of the water-barometer and the sp gr σ of mercury, find the height at which a mercury-barometer will stand in a diving bell with its top at a given depth a of water.

How will this be affected if a block of wood be floated inside the bell, (1) if the wood comes from outside, (2) if it falls from a shelf in the interior?

48. A diving-bell stands on the floor of a dock with a height h of its upper part occupied by air. The weight of the bell is equal to the weight of water that would fill it to a height a . Shew that, as it is being hauled up by the chain, it will become buoyant at a certain stage and rush up to the surface, if the ratio of the depth of the dock to the height of the water-barometer exceed $\frac{\rho - \sigma}{\rho} \frac{a}{h} - 1$, where σ is the density of water and ρ that of the iron of which the bell is made.

[The height of the bell, and hence also h , are to be considered as small quantities compared with the depth of the dock and the height of the water-barometer.]

49. A body floats at the surface of water, the volume of the part not immersed being cA ; a diving-bell, of height b and cross-section A , is placed over it and lowered till the top of the bell is at a distance a below the surface of the water. The volume of the part of the floating body now not immersed is $(c + \gamma\sigma)A$, shew that γ is the positive root of the equation

$$h\gamma^2 + c(h - a - c)\gamma - c^2(a + b) = 0,$$

where h is the height of the water-barometer and σ is the sp gr. of the air, supposed small.

50. A straight tube, making an angle α with the vertical, is filled with liquid of density ρ , and rotates with angular velocity ω about a vertical axis through its lower end which is closed. If the atmospheric pressure is Π , prove that the greatest length of the tube so that no liquid flows out is

$$\frac{g\rho \cos \alpha + \omega \sin \alpha \sqrt{2\Pi\rho}}{\omega^2 \rho \sin^2 \alpha}.$$

[The pressure must not be negative at the point where it is least.]

51. A solid cylinder floats in water in a cylindrical vessel, and the system rotates about the common axis of the cylinders with angular velocity ω . If R, r be the radii of the vessel and cylinder, prove that the cylinder is depressed by the motion through the space

$$\frac{\omega^2}{4g} (R^2 - r^2).$$

52. The embankment of a reservoir is composed of thin horizontal rough slabs of density ρ , whose coefficient of friction is μ . The top of the embankment is a feet wide, and the side in contact with the water is vertical and na feet deep. Shew that the slope of the outer side to the horizon must be less than either of the angles

$$\cot^{-1} \left[\frac{1}{\mu\rho} - \frac{2}{n} \right] \text{ and } \cot^{-1} \left[\sqrt{\frac{1}{2\rho} + \frac{3}{2n^2}} - \frac{3}{2n} \right].$$

53. Express the pressure of the atmosphere in absolute units when a yard, an ounce, and a minute are the fundamental units, given that the height of the barometer is 30 inches, that the sp. gr. of mercury is 13, and that a cubic foot of water weighs 1000 ounces.

[N.B. The dimensions of the unit of pressure are 1 in mass, -1 in length, and -2 in time.]

54. If the attraction of the Earth at a depth z below the surface were $a + bz$, prove that the pressure at that depth in water would be $\rho (az + \frac{1}{2}bz^2)$ where ρ is the density of water.

55. A cylindrical block of wood of length l and sectional area a is floating with its axis vertical in a lake. If it be pushed down very slowly till it is just immersed prove that the work done is

$$\frac{1}{2} g a l^2 \frac{(\rho - \sigma)^2}{\rho},$$

where ρ, σ denote the densities of water and wood respectively.

56. A cylindrical piece of wood of length l and sectional area a is floating with its axis vertical in a cylindrical vessel of sectional area A which contains water, prove that the work which is done in very slowly pressing down the wood till it is just completely immersed is

$$\frac{1}{2} g a l^2 \left[1 - \frac{a}{A} \right] \frac{(\rho - \sigma)^2}{\rho},$$

where ρ , σ denote the densities of the water and wood respectively

57. Shew that a thin uniform rod will float in a vertical position in stable equilibrium in a liquid of n times its own density if a heavy particle be attached to its lower end of weight greater than $\sqrt{n-1}$ times its own weight

58. A cone, whose vertical angle is a right angle, of sp gr $\frac{1}{2}$ and weight W , floats in water with its vertex downwards. If a weight w (very small compared with W) be attached to a point of the rim of the base, prove that the circular measure of the angle at which the axis is inclined to the vertical is very nearly

$$\frac{4}{3} \frac{w}{\sqrt{4-1} W}.$$

59. A hollow circular cylinder, of radius a and height h , floats in a liquid of density ρ and is filled to a height h' with a liquid of density σ , if its weight be $\pi a^2 h \rho$, find the condition of stability

60. Find the corresponding condition for a hollow cone of height h and semi-vertical angle α , floating with its vertex downwards, if its weight be $\frac{1}{3} \pi \rho h \tan^2 \alpha$

APPENDIX.

THE Student who is acquainted with the Integral Calculus, and the methods of finding the centre of gravity of bodies by its use, or of finding the centre of action of parallel forces, may determine the position of centres of pressure in the way shown in the following cases

Rectangle. In the figure of Art 156, let $AA_r = x$, and let $A_r A_{r+1}$ be a small increment dx of x . Then the area $A_r D_{r+1}$ is $a \times dx$, and since the pressure on each point of it is practically the same and equal to $w \times x$, the thrust on this element is $awx \times dx$

Hence, as in *Statics*, Art 111, and by the principles of the Integral Calculus,

$$\bar{x} = \frac{\sum awx dx \times x}{\sum awx dx} = \frac{\int_0^b awx^2 dx}{\int_0^b awx dx}$$

$$= \frac{\left[\frac{x^3}{3} \right]_0^b}{\left[\frac{x^2}{2} \right]_0^b} = \frac{\frac{b^3}{3}}{\frac{b^2}{2}} = \frac{2}{3} b$$

Triangle with its vertex in the surface and base horizontal. In the figure of Art. 157 let $AD_r = x$, and

let $D_r D_{r+1}$ be a small increment dx of x . Then the area $B_r C_{r+1}$ is proportional to $B_r C_r \times D_r D_{r+1}$.

$$\text{Also} \quad B_r C_r = BC \times \frac{AD_r}{AD} = \frac{a}{k} \times x,$$

where $AD = k$. Hence in the limit the area of $B_r C_{r+1}$ is proportional to $\frac{ax}{k} \times dx$. Also the pressure on each element of $B_r C_{r+1}$ is very nearly equal to that at D_r , and is thus proportional to $w \cdot x$. Hence the thrust on the element $B_r C_{r+1}$ is proportional to $\frac{awx^2}{k} \times dx$. Therefore, as in *Statics*, Art 111, and by the principles of the Integral Calculus,

$$\begin{aligned} \bar{x} &= \frac{\sum \frac{aw}{k} x^2 dx \times x}{\sum \frac{aw}{k} x^2 dx} = \frac{\int_0^k x^3 dx}{\int_0^k x^2 dx} \\ &= \frac{\left[\frac{x^4}{4} \right]_0^k}{\left[\frac{x^3}{3} \right]_0^k} = \frac{\frac{k^4}{4}}{\frac{k^3}{3}} = \frac{3}{4} k = \frac{3}{4} AD. \end{aligned}$$

Triangle with its base in the surface. In the figure of Page 194, let $DR = x$ and let RS be a small increment dx of x . Then, if $DA = k$, we have

$$PQ = BC \frac{AR}{AD} = a \frac{k-x}{k},$$

so that the area of PU is proportional to $a \frac{k-x}{k} dx$ in the limit.

As in the last case the pressure at each point of PU is very nearly that at R , and is thus proportional to $w \cdot x$.

Hence, when dx is very small, the thrust on PU is proportional to

$$a \frac{k-x}{k} dx \times wx.$$

Hence, as before,

$$\begin{aligned} \bar{w} &= \frac{\sum a \frac{k-x}{k} w \cdot x \, dx \times x}{\sum a \frac{k-x}{k} w \, a \, dx} \\ &= \frac{\int_0^k x^2 (k-x) \, dx}{\int_0^k x (k-x) \, dx} \\ &= \frac{\left[k \frac{x^3}{3} - \frac{x^4}{4} \right]_0^k}{\left[k \frac{x^2}{2} - \frac{x^3}{3} \right]_0^k} = \frac{\frac{k^4}{3} - \frac{k^4}{4}}{\frac{k^3}{2} - \frac{k^3}{3}} = \frac{k}{\frac{2}{3}} = \frac{1}{2} DA. \end{aligned}$$

The result of Art 119 may be more easily obtained by the use of the Integral Calculus

Let p be the pressure at a height x , $p + \Delta p$ that at height $x + \Delta x$, where Δx is small, and ρ the density at height x , so that

$$p = k\rho \quad (1)$$

Then, considering the equilibrium of the element Δx of a thin column as in Art 119, we have

$$p = p + \Delta p + g\rho\Delta x$$

[For this element is pressed upwards by p , and downwards by $p + \Delta p$]

Hence, cancelling and proceeding to the limit, we have

$$\frac{dp}{dx} = -g\rho$$

Hence, by (1),
$$\frac{d\rho}{dx} = -\frac{g}{k} \rho$$

$$\therefore \frac{d\rho}{\rho} = -\frac{g}{k} dx$$

$$\therefore \log \rho = -\frac{g}{k} x + \text{a constant } C \quad (2)$$

But when $x=0$, $\rho = \rho_1$

$$\log \rho_1 = -\frac{g}{k} \cdot 0 + C \quad . \quad . \quad (3)$$

Subtracting (3) from (2), we have

$$\log \frac{\rho}{\rho_1} = -\frac{g}{k} x,$$

$$\text{i.e. } \rho = \rho_1 e^{-\frac{gx}{k}}$$

This is the result of Art 119, and gives the density at any height x .

ANSWERS.

I. (Page 12)

1. 156.25 kilos 2. 56 lbs wt. 3. $2\frac{29}{4}$ lbs wt
 4. 7.1 5. $31\frac{3}{4}$ lbs wt, $\frac{2430}{7}\pi - 1091\frac{1}{49}$ tons wt
 7. 144 lbs wt per sq inch.
 8. $\frac{128}{\pi} = 40\frac{8}{11}$ lbs wt per sq inch.
 9. 80 lbs wt per sq inch

II. (Pages 17, 18.)

1. $562\frac{1}{2}$ lbs wt 2. 4629 3. 13598 lbs wt
 4. 13600 grammes wt 5. 26 6. $1\frac{237}{8}$ cub ft
 7. Its volume is increased by 1153 cub. cms.
 8. 572 . . , taking $\pi = \frac{22}{7}$. 9. $\frac{9}{278}$ sq in²
 10. $6\frac{2}{3}$ 11. 015625 cub. metre. 12. 8721
 13. 49.9... 14. 16

III. (Pages 21, 22.)

1. 1 3 2. 9658. 3. .815.
 4. 15 ozs 5. $\frac{6}{7}$ cub ft
 6. 342 cc and 110 cc 7. $\frac{1}{4}(\rho_1 + \rho_2 + 2\rho_3)$
 8. 6 and 2. 9. 9375. 10. $\frac{249}{1615}$ cub cms
 11. $2(s - s_1)(s_2 - s') = (s_2 - s)(s' - s_1)$, and
 $3(s - s_1)(s_2 - s'') = (s_2 - s)(s'' - s_1)$.

IV. (Pages 34—36.)

- 1 2291 $\frac{2}{3}$ lbs wt 2 195 84 ft 3 7 $\frac{3}{4}$ ft
 4 36 864 ft 5 4 miles 1561 6 yds
 6 2833 $\frac{1}{3}$ lbs wt 7 98 ft 8 54 ft
 9 14 $\frac{109}{144}$ 10 15 45 11. 36 77 metres
 12 73 55 cms 13 102000
 14 19 34 lbs wt , 2306 6 lbs wt. 15 15 $\frac{5}{8}$.
 16 2021 04 grams wt 17 1 $\frac{367}{432}$
 18 14 9556 cub. ins 23 $\frac{1}{2}n(n+1) \rho \rho h$.

V (Pages 41—45.)

- 1 750 lbs wt. 2 162 $\frac{7}{8}$ lbs wt
 3 67500 grammes wt on the upper face, 94500 grammes wt on the lower face, 81000 grammes wt on each vertical face
 4. 320 lbs wt 5 104 $\frac{1}{2}$ tons wt.
 6 5062 5 grammes wt
 7 295617 π grammes wt
 8 15066 $\frac{27}{8}$ tons wt
 9 $\frac{1}{2}\frac{25}{3}$ lbs wt per sq in , $\frac{1}{18}\frac{5}{3}\pi = 21\frac{52}{3}$ lbs. wt
 10. It divides the vertical sides in the ratio '2 + 1 · 1
 11. 1 2 kilogr. wt. 12 1971 8 lbs wt
 13. 515 $\frac{5}{8}$ lbs. wt. 14. 6 $\frac{2}{5}$ ft., 1 $\frac{3}{5}$ ft
 15. 1250 and 1312 $\frac{1}{2}$ lbs wt respectively 17. 9 ft
 18. $\frac{\sqrt{3}}{4} a^2 dw$, $\frac{\sqrt{3}}{4} a^2 \left(d + \frac{a\sqrt{6}}{9} \right) w$, $\frac{\sqrt{2}}{12} a^3 w$.

19 25 322 ft 21 $abw [c + \frac{1}{2}b \cos \theta]$.

22 $\pi a^2 w [c \mp \frac{1}{2}h \cos \theta]$.

27. The required line is AX , where X is on DC and $DX = \frac{3}{4}DC$.

28 If x be the depth of the point in which the dividing line cuts a vertical side a of the square, then

$$2x^3 - 6a^2x + a^3 = 0$$

29 Divide the horizontal diameter into equal parts, ordinates to it at the points of division will divide the arc of the semicircle at the required points

30 If x be the depth of the point at which the dividing line cuts CB , and a and β be the depths of A and B , then

$$2x^2 + 2ax - \beta(a + \beta) = 0$$

35 The depth of the plane is $\frac{h}{2}\sqrt[3]{4}$ in the first case, and is $\frac{h}{2}$ in the second case, where h is the height of the cone.

VI. (Page 47.)

2 It must be half filled 3 $20\frac{5}{6}$ lbs

VII. (Pages 53-55)

1. 16 9 3 3 1 4 $\left(\frac{\pi}{2} + 2\right) r^2hw$.

6 (1) $r^2hw \left(1 - \frac{\pi}{6}\right)$, (2) $r^2hw \left(1 + \frac{\pi}{6}\right)$.

7. $\frac{3}{4}\frac{1}{18}\pi$ lbs wt.

VIII. (Pages 58, 59.)

1 $\pi a^2 h w$, $\pi a^2 w \sqrt{h^2 + \frac{4a^2}{9}}$ at $\tan^{-1} \frac{2a}{3h}$ to the horizontal

2 $\frac{1}{2} h h' w$, where h' is the height of the cone and $\frac{1}{2}$ the radius of its base

3 $\frac{1}{3} h^2 w$

4 $\frac{a^2 h w}{2} \sqrt{\pi^2 + 16}$ through the centre at an $\angle \tan^{-1} \frac{\pi}{4}$ to the horizontal

5 At an $\angle \tan^{-1} \frac{3\pi a}{5h}$ to the horizon.

7 $\frac{1}{8} a h w \sqrt{\pi^2 a^2 + 4h^2}$

IX (Pages 63, 64.)

3 $\tan^{-1} \frac{109}{8}$

4 $W(1 + 3 \sin^2 a)$, $3W \sin a \cos a$, where $2a$ is the vertical \angle of the cone and W is the weight of the contained water

7. $3W \tan a \cos^2(a + \beta)$;

$$W [1 + 3 \tan a \sin(a + \beta) \cos(a + \beta)]$$

8 $\frac{\sqrt{13}}{3} \pi a^3 w$ at an angle $\tan^{-1} \frac{2}{3}$ to the horizontal

through the centre of the hemispherical end, a being the radius of this end

X. (Pages 67--70)

- 1 $2\frac{6073}{10800}$ cub ft 2 $3\frac{1}{2}$ lbs 3 50 cub cms
 4 4, 00053 5 $45\frac{5}{1111}$ cub metres
 6 $31\frac{1171}{150}$ cub cms ; 8 661 7 $257\frac{41}{107}$ ft
 8 726 inch 12 25 13 $4\frac{3}{4}$ ins
 14 There is a cavity of volume 1 cub cm
 15 $463\frac{1}{200}$ cub ins 16 23 17 $1\frac{1}{6}$
 18 $\frac{3}{a+b+c}$, $\frac{bc+ca+ab}{3abc}$ 19 30 lbs
 20 900 cub ins., 10 ins 27 $h\left(1-\frac{\rho}{\sigma}\right)^{\frac{3}{2}}$
 28 $\frac{343}{207}$ 30 $\frac{h}{2} \sqrt[3]{4}$

XI. (Pages 71, 72.)

- 1 50065 2 $\frac{2}{5}$ cub in 3 13 6054
 4 407 618 6 It will sink 7 $n = \frac{m+1}{2}$
 9 The new depth of immersion is to the original depth
 as 3935 3948

XII (Pages 75 -77.)

1. (1) 12 lbs wt , (2) 6 lbs wt 3 37380 37249
 4 $97\frac{5}{8}$ lbs wt , $145\frac{17}{8}$ lbs wt 5 185.
 6 15 grammes wt 7. 2·3.
 8 The piece of wood 9 5
 10 The first is increased, and the second diminished,
 by a weight equal to that of the water displaced by the
 body
 12 2 cub ins , $\frac{875}{1728}$ lbs wt.
 13 $7\frac{3}{4}$ lbs wt , 56 lbs wt.

XIII (Pages 78, 79)

- 1 90 grammes wt 3. 5 lbs wt.
 4. 1580000 grammes 5 11 $\frac{4}{3}$ oz wt.
 6 $\frac{3}{28} g.$ 7. $\frac{27}{82}$

XV. (Page 84.)

4 (1) $\frac{1}{2} \sqrt{2}$, (2) r , where r is the radius of the common base

XVI (Pages 87-90)

- 3 $\frac{1}{8}, \frac{1}{4}$
 10 It rises through a distance $\frac{(\sigma_1 - \rho)(\sigma_3 - \sigma_2)}{(\sigma_1 - \sigma_2)(\sigma_1 - \sigma_3)} h.$
 17 $\frac{2\sigma_2\sigma_3}{\sigma_2 + \sigma_3}, \frac{2\sigma_3\sigma_1}{\sigma_3 + \sigma_1}, \frac{2\sigma_1\sigma_2}{\sigma_1 + \sigma_2}.$ 19. 7 : 18.
 20 $\frac{11}{18}$
 22 $12b\sigma \sin^2 \theta (b \cos \theta - a \sin \theta)$
 $= 4a^2 \cos \theta (2 - \cos^2 \theta) - 6ac + 3c^2 \cos \theta.$

XVII. (Page 95.)

- 1 75 2. .7864 nearly. 3. $7\frac{9}{15}$
 4 2 0458 .. 5. $6\frac{1}{4}.$

XVIII. (Pages 100, 101.)

- 1 1 525 2 3. 3. $2\frac{6}{19}.$ 4 £55.
 5 $\frac{12}{13}$ 6 $\frac{1}{3}$ 7. $\frac{5}{8}$ 8. 848
 9 9413 nearly 10. 1 841. 11. 1 6.
 12 9 13. .87, 50 cub cms.
 14 30 grms wt., 2. 15. 5 16. $1\frac{1}{12}.$
 17 $7\frac{7}{84}$ lbs., $5\frac{1}{17}$ lbs of gold and $1\frac{2}{84}$ lbs of silver.

XIX (Pages 108—110.)

- 1 3 456, 3·1418 and 2 88 2. 1 03 3 $6\frac{2}{13}$ ins
 4 ' 0947... 5 $1\frac{7}{17}$ cub cms 6 $\frac{1}{501}$ th
 7 906 8 10 13 9 18 19
 10. $8\frac{7}{8}$ oz. 11. 2 5 12 8 13 $2\frac{2}{7}$ oz

XX. (Pages 111, 112.)

- 1 27·2. 2 6 inches
 3. At the bottom of the vertical tube containing the oil
 4 1·7. 5 14 9556 cub inches 6 $\frac{40}{83}$ cms

XXI. (Page 126.)

1. 1169 256 cms 2. 929082 grams wt, taking $\pi = \frac{22}{7}$
 3 $1\frac{4}{13}$, the height would be lessened by a distance x ,
 such that the weight of the mercury in a length x of the
 tube would equal the weight of the bullet
 4. 2 623 cms 5. $1\frac{1}{8}$ inch.

XXII. (Pages 135—138.)

1. 001292 2 An increase of $8\frac{4}{13}$ grams wt
 3. 31·5 feet
 4 Till the level of the water inside is $2h$ feet below
 the surface of the water, $7h$
 5 32 75 ft 6 63 cms
 8 The pressures on the two faces are $56\frac{1}{4}$ and $22\frac{1}{2}$ lbs
 wt. per square inch, 8 inches
 9 (1) It would float, (2) it would sink

- 10 34.4 lbs wt nearly 13 75, 30 ft
 15 $\frac{1}{8}\frac{1}{2}$ inch. 16 $\sqrt[3]{32}$ inches 19 150 lbs wt
 20 $\frac{9}{32h + 233}$ ft, where h is the height of the water-barometer in feet.

XXIII. (Pages 141, 142.)

- 1 (1) 9484 cub cms, 790 cub ft
 2 $8\frac{1}{2}$ cub inches 3 10 cub inches
 4 429 224 7 2870000 nearly

XXIV. (Pages 149—151)

- 2 $\frac{7}{5}$ cub inch 3 5 inches 4 2998 inches
 5 $32\frac{1}{4}$ inches
 7 That due to $63\frac{1}{2}$ inches of mercury, $10\frac{4}{5}$ ins
 8 30 inches 9 842952 grammes weight
 10 299 inches. 11 $\frac{1}{16}\sigma$.

XXV. (Pages 156—160.)

- 1 345 atmospheres, nearly 2 $1\frac{1}{5}$ ft
 3 $14\frac{1}{8}$ ft 4 20 ft, $132\frac{6}{17}$ cub ft
 5 500 cub ft 6 The quantities are $\epsilon, \beta, 2$
 7 The depth of the top of the bell is 3 inches, the height of the water-barometer is 33 ft
 8 $33\frac{1}{2}$ ins, 3 ft 9 ins 9 It remains constant
 12 The air will flow out 13 $\frac{2-3\sigma}{4}$ approx.

14. 33 feet

15 $\frac{3h}{2} + \frac{a}{6}$, where h is the height of the water barometer and a that of the bell

16 (1) $\frac{\sigma}{12}(h' - h) - b\sqrt{\frac{h}{h'}}$, (2) $\frac{\sigma}{12}(h' - h) - \frac{h}{h'}$, where σ is the sp gr of mercury

XXVI (Pages 172--174.)

- 1 The height varies from 31.73 to 35.13 feet
 2 42 ft 1 in 3 33 ft 4 ins 4 80
 5 It will 6 2 feet, $32 - 16\sqrt{2} = 9.37$ feet nearly
 7 $8680\frac{5}{8}$ lbs wt 8 $260\frac{5}{12}$ lbs wt.
 9 $\frac{625\pi}{8}$ lbs wt, $\frac{1125\pi}{8}$ lbs wt
 10 *Aw CL BL*, with the notation of Arts 128 and 130
 11 40π kilogrammes weight, 600π kilogrammes weight
 13 $2\frac{5}{8}$ feet 14 No, $25\frac{1}{2}$ ft

XXVII (Pages 183 -185.)

- 1 3 : 1. 2 They are as 9^8 10^8
 4 The final pressure is to the original pressure as 10^8 11^8 , i.e. nearly as 10 21
 5 (1) 5, (2) 8 6 4 7 $8\frac{8}{9}$ ins
 9 Between 37 and 38 10 20
 11 22 13 $\frac{2465}{81}$
 14 One quarter of atmospheric density

HYDROSTATICUS.

XXVIII. (Page 189.)

- 1 34 feet 2 22 ft 8 ins

XXIX. (Pages 199, 200.)

- 3 $\frac{5}{24}aw$
7 3 6 4

XXX. (Pages 203, 204)

- 2 $\frac{6k^2 + h^2 - 4hk}{2(3h - h)}$ 3 $\frac{6k^2 - 8hk + 3h^2}{2(3k - 2h)}$
4 $3\frac{9}{74}$ ft 6 $\frac{1}{8} \frac{h\delta}{h + \delta}$

XXXI (Pages 208—212.)

- 2 $\frac{x^2 + xy + y^2 + 2h(x + y)}{2(x + y + 3h)}$
4 Its depth is $\frac{5}{8}\frac{5}{4}$ times that of the centre
7 $\frac{7\sqrt{3}}{20}a$, where a is the length of a side.

XXXII. (Pages 222—227.)

- 1 $\frac{\sqrt{2gh}}{a}$
4 $g\rho [h - \frac{\omega^2}{2g}(a^2 - y^2)]$ at a distance y from the centre
6 $\frac{\sqrt{2gh}}{1}$ 19 $\frac{\pi}{4} \frac{\omega^2 a^4}{g}$ or $\frac{2\pi}{3} \frac{a^3 \omega^6 - 2g^3}{\omega^6}$, according
is $a\omega^2 \leq 2g$
21 $\frac{1}{4} \sqrt{\frac{6g}{a}}$.

XXXIV (Page 239)

- 1 2.3 2 500 lbs. per sq in
 3 $\frac{5}{144}$ inch 4 $a [1 + at]^{\frac{1}{2}}$

MISCELLANEOUS EXAMPLES. (Pages 240—248)

- 1 $89\frac{31}{41}$ yds
 2 6 grammes per cub cm, $1666\frac{2}{3}$ cub cms
 3 $\frac{50}{83}$ 4 357π grammes 5. 11 9
 8 29.4 cms 9 32000 cub ft
 10 $\frac{375\pi}{64} - 8 =$ about 10.4 ozs 11 1.32
 12 75 13 1.5 14 $\frac{8}{305}$ of the original amount
 15 5.05 inches 16 337.312
 19 Its height = $\frac{r^2}{r_1^2} \sigma \frac{h}{4}$
 20 If D be the middle point of BC , then O lies on DA
 and $DO = \frac{1}{\sqrt{3}} \cdot DA$
 21 $27 \cdot 64$, $\frac{9h}{64}$, where h is the height of the cone
 22 $18\pi w \sqrt{10}$ at $\tan^{-1} \frac{1}{3}$ to the horizon
 25 (1) It rises, (2) It falls in general
 29 1020 cms, 2665600. 33 38.85
 42 $\sqrt{\frac{4g}{3a}}$

$$43 \quad \frac{\pi}{3} \omega l^3 \sin^2 a \cos \sigma \sqrt{1 + 3 \sin^2 a}$$

$$44 \quad \tan^{-1} \left[\frac{8}{3} \sqrt{1 - 2\lambda n + 2\lambda^2 n^2} \right], \text{ where } \lambda = \frac{\sigma}{1 - \sigma}.$$

$$47 \quad \frac{1}{2\sigma} [a + h + \sqrt{(a + h)^2 + 4hb}], \text{ with the notation of}$$

Art 123, (1) it rises, (2) it falls

$$53 \quad 11232 \times 10^8, \text{ taking } g = 32$$

$$59 \quad 2(nh\rho + h'\sigma)^2 > \rho\sigma(2h'^2 + a^2) + \rho^2(2nh^2 - a^2)$$

$$60 \quad (nh^3\rho + h'^3\sigma)^4 > \rho [h'^4\sigma + \frac{8}{3}nh^4\rho \cos^2 \alpha]^3$$

THE PITT PRESS SERIES
AND THE
CAMBRIDGE SERIES FOR SCHOOLS
AND TRAINING COLLEGES

Volumes of the latter series are marked by a dagger †.

COMPLETE LIST

GREEK

<i>Author</i>	<i>Work</i>	<i>Editor</i>	<i>Price</i>
Aeschylus	Prometheus Vinctus	Rackham	2/1
Aristophanes	Aves—Plutus—Ranae	Green	3/6 <i>each</i>
„	Nubes, Vespae	Graves	3/6 <i>each</i>
„	Acharnians	„	3/
„	Peace	„	3/1
Demosthenes	Olynthiacs	Glover	2/1
„	Philippics I, II, III	G A Davies	2/1
Euripides	Alcestis	Hadley	2/1
„	Hecuba	Hadley	2/1
„	Helena	Pearson	3/1
„	Heracleidae	Pearson	3/1
„	Hercules Furens	Gray & Hutchinson	2/1
„	Hippolytus	Hadley	2/1
„	Iphigenia in Aulis	Headlam	2/1
„	Medea	„	2/1
„	Orestes	Wedd	4/1
„	Phocnissae	Pearson	4/1
Herodotus	Book I	Sleeman	4/1
„	„ V	Shuckburgh	3/1
„	„ IV, VI, VIII, IX	„	4/1 <i>each</i>
„	„ IX 1—89	„	2/1
Homer	Odyssey IX, X	Edwards	2/6 <i>each</i>
„	„ XXI	„	2/1
„	„ XI	Nairn	2/1
„	Iliad VI, XXII, XXIII, XXIV	Edwards	2/1 <i>each</i>
„	Iliad IX and X	Lawson	2/1
Lucian	Somnium, Charon, etc	Heitland	3/1
„	Menippus and Timon	Mackie	3/1
Plato	Apologia Socratis	Adam	3/1
„	Crito, Euthyphro	„	2/6 <i>each</i>
„	Protagoras	J & A M Adam	4/1
Plutarch	Demosthenes	Holden	4/1
„	Gracchi	„	6/1
„	Nicias	„	5/1
„	Sulla	„	6/1
„	Timoleon	„	6/1

THE PITT PRESS SERIES, ETC.

GREEK *continued*

<i>Author</i>	<i>Work</i>	<i>Editor</i>	<i>Price</i>
Sophocles	Oedipus Tyrannus	Jebb	4/-
Thucydides	Book III	Spratt	5/-
"	Book VI	"	6/-
"	Book VII	Holden	5/-
Xenophon	Agésilas	Hailstone	2/6
"	Anabasis I-II	Pretor	4/-
"	" I, III, IV, V	"	2/ each
"	" II, VI, VII	"	2/6 each
† "	" I, II, III, IV, V, VI	Edwards	1/6 each
	<i>(With complete vocabularies)</i>		
"	Hellenics I-II	"	3/6
"	Cyropaedea I	Shuckburgh	2/6
"	" II	"	2/-
"	" III, IV, V	Holden	5/-
"	" VI, VII, VIII	"	5/-
"	Memorabilia I, II	Edwards	2/6 each

LATIN

*The volumes marked * contain vocabularies*

Bede	Eccl History III, IV	Mayor & Lumby	7/6
Caesar	De Bello Gallico		
	Com I, III, VI, VIII	Peskett	1/6 each
	" II-III, and VII	"	2/- each
	" I-III	"	3/-
	" IV-V	"	1/6
*† "	" I, II, III, IV, V, VI, VII	Shuckburgh	1/6 each
"	De Bello Gallico Bk I	"	1/9
	<i>(With vocabularies only no notes)</i>		
"	De Bello Gallico Bk VII		-/8
	<i>(Text only)</i>		
"	De Bello Civili Com I	Peskett	3/-
"	" " Com III	"	2/6
Cicero	Actio Prima in C Verrem	Cowie	1/6
"	De Amicitia, De Senectute	Reid	3/6 each
"	De Officiis Bk III	Holden	2/-
"	Pro Lege Manilia	Nicol	1/6
"	Div in Q Caec et Actio		
	Prima in C Verrem	Heitland & Cowie	3/-
"	Ep ad Atticum Lib II	Pretor	3/-
"	Orations against Catiline	Nicol	2/6
*† "	In Catilinam I	Flather	1/6
"	Philippica Secunda	Peskett	3/6
"	Pro Archia Poeta	Reid	2/-
"	" Balbo	"	1/6
"	" Milone	Reid	2/6
"	" Murena	Heitland	3/-
"	" Plancio	Holden	4/6
"	" Roscio	Nicol	2/6
"	" Sulla	Reid	3/6
"	Somnium Scipionis	Pearman	2/-
* "	Easy selections from correspondence	Duff	1/6

THE PITT PRESS SERIES, ETC.

LATIN *continued*

<i>Author</i>	<i>Work</i>	<i>Editor</i>	<i>Price</i>
*Cornelius Nepos	Four parts	Shuckburgh	1/6 <i>each</i>
*Erasmus	Colloquia Latina	G M Edwards	1/6
"	Colloquia Latina (<i>With vocabulary only no notes</i>)	"	-/9
"	Altera Colloquia Latina	"	1/6
Horace	Epistles. Bk I	Shuckburgh	2/6
"	Odes and Epodes	Gow	5/-
"	Odes Books I, III	"	2/- <i>each</i>
"	" Books II, IV, Epodes	"	1/6 <i>each</i>
"	Satires Book I	"	2/-
"	" " II	"	2/-
Juvenal	Satires	Duff	5/-
Livy	Book I	H J Edwards	<i>In the Press</i>
"	" II	Conway	2/6
"	" IV, XXVII	Stephenson	2/6 <i>each</i>
"	" V	Whibley	2/6
"	" VI	Marshall	2/6
"	" IX	Anderson	2/6
"	" XXI, XXII	Dimsdale	2/6 <i>each</i>
†,, (adapted from)	Story of the Kings of Rome	G M Edwards	1/6
"	" " " "	"	
"	(<i>With vocabulary only no notes</i>)	"	-/8
"	Horatius and other Stories	"	1/6
"	" " " "	"	-/9
"	(<i>With vocabulary only no notes</i>)	"	
"	Exercises on Edwards's The Story of the Kings of Rome	Caldecott	-/6 <i>net</i>
Lucan	Pharsalia Bk I	Heitland & Haskins	1/6
"	De Bello Civili Bk VII	Postgate	2/-
Lucretius	Books III and V	Duff	2/- <i>each</i>
Ovid	Fasti Book VI	Sidgwick	1/6
"	Metamorphoses, Bk I	Dowdall	1/6
"	" Bk VIII	Summers	1/6
* "	" and other stories	G M Edwards	1/6
*†,,	Selections from the Tristia	Simpson	1/6
†Phaedrus	Fables Bks I and II	Flather	1/6
Plautus	Epidicus	Gray	3/-
"	Stichus	Fennell	2/6
"	Trinummus	Gray	3/6
Pliny	Letters Book VI	Duff	2/6
Quintus Curtius	Alexander in India	Heitland & Raven	3/6
Sallust	Catiline	Summers	2/-
"	Jugurtha	"	2/6
Tacitus	Agricola and Germania	Stephenson	3/-
"	Histories Bk I	Davies	2/6
"	" Bk III	Summers	2/6
Terence	Haautimorumenos	Gray	3/-
Vergil	Aeneid I to XII	Sidgwick	1/6 <i>each</i>
*†,,	" I, II, III, V, VI, IX, X, XI, XII	"	1/6 <i>each</i>
"	Bucolics	"	1/6
"	Georgics I, II, and III, IV	"	2/- <i>each</i>
"	Complete Works, Vol I, Text	"	3/6
"	" " Vol II, Notes	"	4/6
"	Opera Omnia	B II Kennedy	3/6

THE PITT PRESS SERIES, ETC.

FRENCH

The volumes marked * contain vocabularies

Author	Work	Editor	Price
About	Le Roi des Montagnes	Ropes	2/-
Balzac	Le Médecin de Campagne	Payen Payne	3/-
*Biart	Quand j'étais petit, Pts I, II	Boielle	2/- each
Boileau	L'Art Poétique	Nichol Smith	2/6
Corneille	Polyeucte	Braunholtz	2/-
"	Le Cid	Eve	2/-
De Bonnechose	Le zaire Hoche	Colbeck	2/-
"	Bertrand du Guesclin	Leathes	2/-
"	" Part II	"	1/6
D'Harleville	Le Vieux Celibataire	Masson	2/-
Delavigne	Louis XI	Eve	2/-
"	Les Enfants d'Edouard	"	2/-
De Lamartine	Jeanne d'Arc	Clapin & Ropes	1/6
De Vigny	La Canne de Jonc	Eve	1/6
*Dumas	La Fortune de D'Artagnan	Ropes	2/-
*Enault	Le Chien du Capitaine	Verrall	2/-
"	"	"	"
	(With vocabulary only no notes)		-/9
Erckmann-Chatrian	La Guerre	Clapin	3/- each
"	Waterloo, Le Blocus	Ropes	3/-
"	Madame Thérèse	"	3/-
"	Histoire d'un Conscrit	"	3/-
"	Exercices on 'Waterloo'	Wilson-Green	1/-
Gautier	Voyage en Italie (Selections)	Payen Payne	3/-
Guizot	Discours sur l'Histoire de la Révolution d'Angleterre	Eve	2/6
Hugo	Les Burgraves	"	2/6
"	Selected Poems	"	"
Lemercier	Frédegonde et Brunehaut	Masson	2/-
*Malot	Remi et ses Amis	Verrall	2/-
"	Remi en Angleterre	"	2/-
Merimée	Colomba (Abridged)	Ropes	2/-
Michelet	Louis XI & Charles the Bold	"	2/-
Molière	Le Bourgeois Gentilhomme	Clapin	1/6
"	L'École des Femmes	Saintsbury	2/6
"	Les Précieuses ridicules	Braunholtz	2/-
"	" (Abridged edition)	"	1/-
"	Le Misanthrope	"	2/6
"	L'Avare	"	2/6
*Perrault	Fairy Tales	Rippmann	1/6
"	"	"	-/9
	(With vocabulary only no notes)		"
Piron	La Métromanie	Masson	2/-
Ponsard	Charlotte Corday	Ropes	2/-
Racine	Les Plaideurs	Braunholtz	2/-
"	" (Abridged edition)	"	1/-
"	Athalie	Eve	2/-
Saintine	Picciola	Ropes	2/-
Sandau	Mdlle de la Seiglière	"	2/-
Scribe & Legouvé	Bataille de Dames	Bull	2/-
Scribe	Le Verre d'Eau	Colbeck	2/-

THE PITT PRESS SERIES, ETC.

FRENCH *continued*

<i>Author</i>	<i>Work</i>	<i>Editor</i>	<i>Price</i>
Sédaine	Le Philosophe sans le savoir	Bull	2/-
Souvestre	Un Philosophe sous les Toits	Eve	2/-
"	Le Serf & Le Chevrier de Lorraine	Ropes	2/-
*Souvestre	Le Serf	Ropes	1/6
"	"	"	-/9
	<i>(With vocabulary only no notes)</i>		
Spence	French Verse for upper forms		3/-
Stael, Mme de	Le Directoire	Masson & Prothero	2/-
"	Dix Années d'Exil (Book II chapters 1—8)	"	2/-
Thierry	Lettres sur l'histoire de France (XIII—XXIV)	"	2/6
"	Récits des Temps Mérovingiens, I—III	Masson & Ropes	3/-
Voltaire	Histoire du Siècle de Louis XIV, in three parts	Masson & Prothero	2/6 each
Xavier de Maistre	{ La Jeune Sibérienne Le } { Lepreux de la Cité d'Aoste }	Masson	1/6

GERMAN

*The volumes marked * contain vocabularies*

*Andersen	Eight Stories	Rippmann	2/6
Benedix	Dr Wespe	Breul	3/-
Freytag	Der Staat Friedrichs des Grossen	Wagner	2/-
"	Die Journalisten	Eve	2/6
Goethe	Knabenjahre (1749—1761)	Wagner & Cartmell	2/-
"	Hermann und Dorothea	" "	3/6
"	Iphigenie auf Tauris	Breul	3/6
*Grimm	Twenty Stories	Rippmann	3/-
Gutzkow	Zopf und Schwert	Wolstenholme	3/6
*Acklander	Der geheime Agent	Milne Bary	3/-
Hauff	Das Bild des Kaisers	Breul	3/-
"	Das Wirthshaus im Spessart	Schlottmann & Cartmell	3/-
"	Die Karavane	Schlottmann	3/-
* "	Der Schick von Alessandria	Rippmann	2/6
Immermann	Der Oberhof	Wagner	3/-
*Klee	Die deutschen Heldensagen	Wolstenholme	3/-
Kohlrausch	Das Jahr 1813	Cartmell	2/-
Lessing	Minna von Barnhelm	Wolstenholme	3/-
Lessing & Gellert	Selected Fables	Breul	3/-
Raumer	Der erste Kreuzzug	Wagner	2/-
Riehl	Culturgeschichtliche Novellen	Wolstenholme	3/-
* "	Der Ganeiben & Die Gerechtigkeit Gottes	"	3/-
Schiller	Wilhelm Tell	Breul	2/6
"	" (<i>Abridged edition</i>)	"	1/6

THE PITT PRESS SERIES, ETC

GERMAN *continued*

<i>Author</i>	<i>Work</i>	<i>Editor</i>	<i>Price</i>
Schiller	Geschichte des dreissigjahren Kriegs Book III	Breul	3/-
"	Maria Stuart	"	3/6
"	Wallenstein I	"	3/6
"	Wallenstein II	"	3/6
Sybel	Prinz Eugen von Savoyen	Quiggin	2/6
Uhland	Ernst, Herzog von Schwaben	Wolstenholme	3/6
	German Dactylic Poetry	Wagner	3/-
	Ballads on German History	"	2/-

SPANISH

Cervantes	La Ilustre Fiegona &c	Kirkpatrick	3/6
Le Sage & Isla	Los Ladrones de Asturias	Kirkpatrick	3/-
Galdós	Trafalgar	"	4/-

ENGLISH

	Historical Ballads	Sidgwick	1/6
	Old Ballads	"	1/6
	English Patriotic Poetry	Salt	1/-
Bacon	History of the Reign of King Henry VII	Lumby	3/-
"	Essays	West	3/6
"	New Atlantis	G C M Smith	1/6
Burke	American Speeches	Innes	3/-
Chaucer	Prologue and Knight's Tale	M Bentinck Smith	2/6
"	Clerks Tale and Squires Tale	Winstanley	2/6
Cowley	Prose Works	Lumby	4/-
Defoe	Robinson Crusoe, Part I	Masterman	2/-
Earle	Microcosmography	West	3/ & 4/-
Goldsmith	Traveller and Deserted Village	Munson	1/6
Gray	Poems	Tovey	4/-
† "	Ode on the Spring and The Bard	"	8d
† "	Ode on the Spring and The Elegy	"	8d
Kingsley	The Heroes	E A Gardner	1/6
Lamb	Tales from Shakespeare 2 Series	Flather	1/6 each
Macaulay	Lord Clive	Innes	1/6
"	Warren Hastings	"	1/6
"	William Pitt and Earl of Chatham	"	2/6
† "	John Bunyan	"	1/-
† "	John Milton	Flather	1/6
"	Lays and other Poems	"	1/6
"	History of England Chaps I—III	Reddaway	2/-
Mayor	A Sketch of Ancient Philosophy from Thales to Cicero		3/6
"	Handbook of English Metre		2/-
Milton	Arcades	Verity	1/6
"	Ode on the Nativity, L'Alle-gro, Il Penseroso & Lycidas}	"	2/6
† "	Comus & Lycidas	"	2/-
"	Comus	"	1/-
"	Samson Agonistes	"	2/6
"	Sonnets	"	1/6

THE PITT PRESS SERIES, ETC.

ENGLISH *continued*

<i>Author</i>	<i>Work</i>	<i>Editor</i>	<i>Price</i>
Milton	Paradise Lost, six parts	Venty	2/- each
More	History of King Richard III	Iumby	3/6
"	Utopia	"	2/-
Pope	Essay on Criticism	West	2/-
Scott	Mammon	Masterman	2/6
"	Lady of the Lake	"	2/6
"	Lay of the last Minstrel	Flather	2/-
"	Legend of Montrose	Simpson	2/6
"	Lord of the Isles	Flather	2/-
"	Old Mortality	Nicklin	2/6
"	Kenilworth	Flather	2/6
"	The Talisman	A S Gaye	2/-
"	Quentin Durward	Murison	2/-
Shakespeare	A Midsummer-Night's Dream	Verity	1/6
"	Twelfth Night	"	1/6
"	Julius Caesar	"	1/6
"	The Tempest	"	1/6
"	King Lear	"	1/6
"	Merchant of Venice	"	1/6
"	King Richard II	"	1/6
"	As You Like It	"	1/6
"	King Henry V	"	1/6
"	Macbeth	"	1/6
"	Hamlet	"	1/6
Shakespeare &	Fletcher Two Noble Kinsmen	Skeat	3/6
Sidney	An Apologie for Poetrie	Shuckburgh	3/-
Spenser	Fowre Hymnes	Miss Winstanley	2/-
Tennyson	Fifty Poems, 1830—1864	Lobban	2/6
Wordsworth	Selected Poems	Miss Thomson	1/6
West	Elements of English Grammar		2/6
"	English Grammar for Beginners		1/-
"	Key to English Grammars		3/6 net
Carlos	Short History of British India		1/-
Mill	Elementary Commercial Geography		1/6
Bartholomew	Atlas of Commercial Geography		3/-
Robinson	Church Catechism Explained		2/-
Jackson	The Prayer Book Explained Part I		2/6

MATHEMATICS

Ball	Elementary Algebra		4/6
†Blythe	Geometrical Drawing		
	Part I		2/6
	Part II		2/-
Euclid	Books I—VI, XI, XII	H M Taylor	5/-
"	Books I—VI	"	4/-
"	Books I—IV	"	3/-
	Also separately		
"	Books I, & II, III, & IV, v, & VI, XI, & XII		1/6 each
"	Solutions to Exercises in Taylor's		
	Euclid	W W Taylor	10/6

THE PITT PRESS SERIES, ETC.

MATHEMATICS *continued*

<i>Author</i>	<i>Work</i>	<i>Editor</i>	<i>Price</i>
	And separately		
Euclid	Solutions to Bks I—IV	W W Taylor	6/-
"	Solutions to Books VI XI	"	6/-
Hobson & Jessop	Elementary Plane Trigonometry		4/6
Loney	Elements of Statics and Dynamics		7/6
	Part I Elements of Statics		4/6
	" II Elements of Dynamics		3/6
"	Elements of Hydrostatics		4/6
"	Solutions to Examples, Hydrostatics		5/-
"	Solutions of Examples, Statics and Dynamics		7/6
"	Mechanics and Hydrostatics		4/6
Smith, C.	Arithmetic for Schools, with or without answers		3/6
"	Part I Chapters I—VIII Elementary, with or without answers		2/-
"	Part II Chapters IX—XX, with or without answers		2/-
Hale, G	Key to Smith's Arithmetic		7/6

EDUCATIONAL SCIENCE

†Bidder & Baddeley	Domestic Economy		4/6
†Bosanquet	{ The Education of the Young } { from the <i>Republic</i> of Plato }		2/6
†Burnet	Aristotle on Education		2/6
Comenius	Life and Educational Works	S S Laurie	3/6
Farrar	General Aims of the Teacher	} 1 vol.	1/6
Poole	Form Management		
†Hope & Browne	A Manual of School Hygiene		3/6
Locke	Thoughts on Education	K H Quick	3/6
†MacCuna	The Making of Character		2/6
Milton	Lectures on Education	O. Browning	2/-
Sidgwick	On Stimulus		1/-
Thring	Theory and Practice of Teaching		4/6

†Woodward	A Short History of the Expansion of the British Empire (1500—1902)		4/-
† "	An Outline History of the British Empire (1500—1902)		1/6 net

CAMBRIDGE UNIVERSITY PRESS

London FETTER LANE, E.C.

C F CLAY, MANAGER

Edinburgh 100, PRINCES STREET

